

A
CO
C
D
E
F
G
H
I
J
K
L
M

CO

SECTION

ENGINE COOLING SYSTEM

CONTENTS

VQ35DE	
PRECAUTIONS	3
Precautions for Supplemental Restraint System (SRS) "AIR BAG" and "SEAT BELT PRE-TENSIONER"	3
Precautions for Liquid Gasket	3
REMOVAL OF LIQUID GASKET SEALING	3
LIQUID GASKET APPLICATION PROCEDURE...	3
PREPARATION	5
Special Service Tools	5
Commercial Service Tools	6
OVERHEATING CAUSE ANALYSIS	7
Troubleshooting Chart	7
COOLING SYSTEM	9
Cooling Circuit	9
System Chart	10
ENGINE COOLANT	11
Inspection	11
LEVEL CHECK	11
LEAK CHECK	11
Changing Engine Coolant	11
DRAINING ENGINE COOLANT	11
REFILLING ENGINE COOLANT	12
FLUSHING COOLING SYSTEM	13
RADIATOR	14
Components	14
Removal and Installation	14
REMOVAL	14
INSTALLATION	16
INSPECTION AFTER INSTALLATION	16
Checking Radiator Cap	16
Checking Radiator	16
RADIATOR (ALUMINUM TYPE)	18
Components	18
Disassembly and Assembly	18
PREPARATION	18
DISASSEMBLY	18
ASSEMBLY	19
INSPECTION	21
COOLING FAN	22
Components	22
Removal and Installation	22
REMOVAL	22
INSTALLATION	22
INSPECTION AFTER INSTALLATION	22
Disassembly and Assembly	23
DISASSEMBLY	23
INSPECTION AFTER DISASSEMBLY	23
ASSEMBLY	23
WATER PUMP	24
Components	24
Removal and Installation	24
REMOVAL	24
INSPECTION AFTER REMOVAL	26
INSTALLATION	26
INSPECTION AFTER INSTALLATION	28
WATER INLET AND THERMOSTAT ASSEMBLY ...	29
Components	29
Removal and Installation	29
REMOVAL	29
INSPECTION AFTER REMOVAL	30
INSTALLATION	30
INSPECTION AFTER INSTALLATION	30
WATER OUTLET AND WATER PIPING	31
Components	31
Removal and Installation	31
REMOVAL	31
INSTALLATION	32
INSPECTION AFTER INSTALLATION	32
SERVICE DATA AND SPECIFICATIONS (SDS)	33
Standard and Limit	33
ENGINE COOLANT CAPACITY (APPROXIMATE)	33
RADIATOR	33
THERMOSTAT	33

VK45DE

PRECAUTIONS	34
Precautions for Supplemental Restraint System (SRS) "AIR BAG" and "SEAT BELT PRE-TENSIONER"	34
PREPARATION	35
Special Service Tools	35
Commercial Service Tools	35
OVERHEATING CAUSE ANALYSIS	36
Troubleshooting Chart	36
COOLING SYSTEM	38
Cooling Circuit	38
System Chart	39
ENGINE COOLANT	40
Inspection	40
LEVEL CHECK	40
LEAK CHECK	40
Changing Engine Coolant	40
DRAINING ENGINE COOLANT	40
REFILLING ENGINE COOLANT	41
FLUSHING COOLING SYSTEM	42
RADIATOR	43
Components	43
Removal and Installation	43
REMOVAL	43
INSTALLATION	45
INSPECTION AFTER INSTALLATION	45
Checking Radiator Cap	45
Checking Radiator	45
RADIATOR (ALUMINUM TYPE)	47
Components	47
Disassembly and Assembly	47
PREPARATION	47
DISASSEMBLY	47
ASSEMBLY	48
INSPECTION	50

COOLING FAN	51
Components	51
Removal and Installation	51
REMOVAL	51
INSTALLATION	51
INSPECTION AFTER INSTALLATION	51
Disassembly and Assembly	52
DISASSEMBLY	52
INSPECTION AFTER DISASSEMBLY	52
ASSEMBLY	52
WATER PUMP	53
Components	53
Removal and Installation	53
REMOVAL	53
INSPECTION AFTER REMOVAL	54
INSTALLATION	54
INSPECTION AFTER INSTALLATION	54
THERMOSTAT AND WATER CONTROL VALVE	55
Components	55
Removal and Installation	55
REMOVAL	55
INSPECTION AFTER REMOVAL	56
INSTALLATION	56
INSPECTION AFTER INSTALLATION	57
SERVICE DATA AND SPECIFICATIONS (SDS)	58
Standard and Limit	58
ENGINE COOLANT CAPACITY (APPROXIMATE)	58
RADIATOR	58
THERMOSTAT	58
WATER CONTROL VALVE	58

PRECAUTIONS

PF0:00001

Precautions for Supplemental Restraint System (SRS) “AIR BAG” and “SEAT BELT PRE-TENSIONER”

NBS005RT

The Supplemental Restraint System such as “AIR BAG” and “SEAT BELT PRE-TENSIONER”, used along with a front seat belt, helps to reduce the risk or severity of injury to the driver and front passenger for certain types of collision. This system includes seat belt switch inputs and dual stage front air bag modules. The SRS system uses the seat belt switches to determine the front air bag deployment, and may only deploy one front air bag, depending on the severity of a collision and whether the front occupants are belted or unbelted. Information necessary to service the system safely is included in the SRS and SB section of this Service Manual.

WARNING:

- To avoid rendering the SRS inoperative, which could increase the risk of personal injury or death in the event of a collision which would result in air bag inflation, all maintenance must be performed by an authorized NISSAN/INFINITI dealer.
- Improper maintenance, including incorrect removal and installation of the SRS, can lead to personal injury caused by unintentional activation of the system. For removal of Spiral Cable and Air Bag Module, see the SRS section.
- Do not use electrical test equipment on any circuit related to the SRS unless instructed to in this Service Manual. SRS wiring harnesses can be identified by yellow and/or orange harnesses or harness connectors.

**Precautions for Liquid Gasket
REMOVAL OF LIQUID GASKET SEALING**

NBS004QK

- After removing mounting nuts and bolts, separate the mating surface using the seal cutter (SST) and remove old liquid gasket sealing.

CAUTION:

Be careful not to damage the mating surfaces.

- Tap the seal cutter to insert it, and then slide it by tapping on the side as shown in the figure.
- In areas where seal cutter is difficult to use, use a plastic hammer to lightly tap the parts, to remove it.

CAUTION:

If for some unavoidable reason tool such as a screwdriver is used, be careful not to damage the mating surfaces.

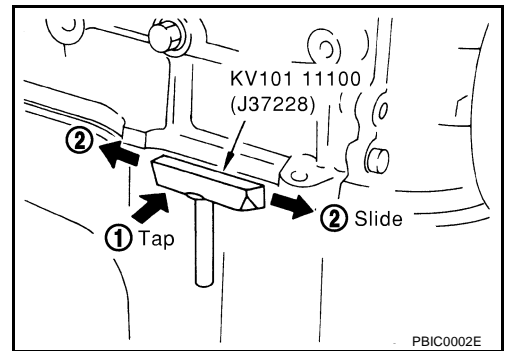

LIQUID GASKET APPLICATION PROCEDURE

1. Using a scraper, remove old liquid gasket adhering to the liquid gasket application surface and the mating surface.
 - Remove liquid gasket completely from the groove of the liquid gasket application surface, mounting bolts, and bolt holes.
2. Wipe the liquid gasket application surface and the mating surface with white gasoline (lighting and heating use) to remove adhering moisture, grease and foreign materials.

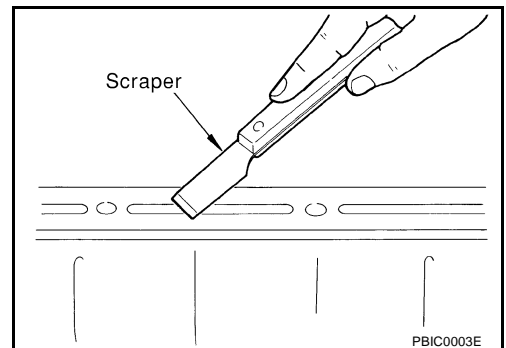

PRECAUTIONS

[VQ35DE]

3. Attach liquid gasket tube to the tube presser [SST: WS39930000 (—)].

Use Genuine RTV Silicone Sealant or equivalent. Refer to [GI-48, "RECOMMENDED CHEMICAL PRODUCTS AND SEALANTS"](#) .

4. Apply liquid gasket without breaks to the specified location with the specified dimensions.

- If there is a groove for the liquid gasket application, apply liquid gasket to the groove.

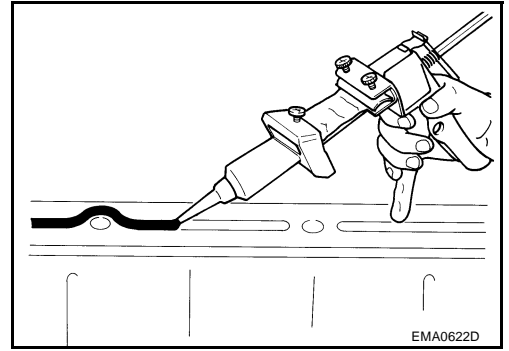

- As for the bolt holes, normally apply liquid gasket inside the holes. Occasionally, it should be applied outside the holes. Make sure to read the text of service manual.
- Within five minutes of liquid gasket application, install the mating component.
- If liquid gasket protrudes, wipe it off immediately.
- Do not retighten after mounting bolts and nuts the installation.
- After 30 minutes or more have passed from the installation, fill engine oil and engine coolant.

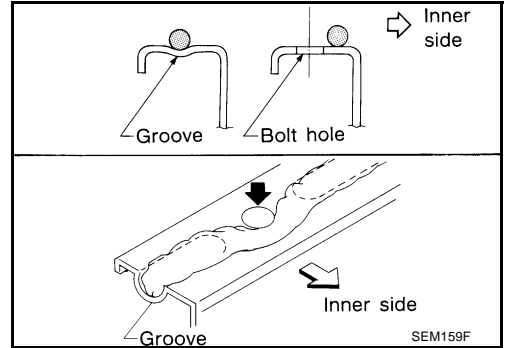

CAUTION:

If there are specific instructions in this manual, observe them.



PREPARATION

PFP:00002

Special Service Tools

NBS004QL

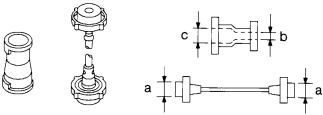
The actual shapes of Kent-Moore tools may differ from those of special service tools illustrated here.

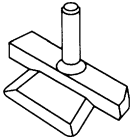
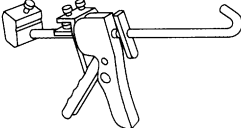
Tool number (Kent-Moore No.) Tool name	Description	
EG17650301 (J33984-A) Radiator cap tester adapter	 <p style="text-align: center;">S-NT564</p>	Adapting radiator cap tester to radiator cap and radiator filler neck a: 28 (1.10) dia. b: 31.4 (1.236) dia. c: 41.3 (1.626) dia. Unit: mm (in)
KV99103510 (—) Radiator plate pliers A	 <p style="text-align: center;">S-NT224</p>	Installing radiator upper and lower tanks
KV99103520 (—) Radiator plate pliers B	 <p style="text-align: center;">S-NT225</p>	Removing radiator upper and lower tanks
KV10111100 (J37228) Seal cutter	 <p style="text-align: center;">NT046</p>	Removing chain tensioner cover and water pump cover
WS39930000 (—) Tube presser	 <p style="text-align: center;">S-NT052</p>	Pressing the tube of liquid gasket

A
CO
C
D
E
F
G
H
I
J
K
L
M

PREPARATION

[VQ35DE]

Commercial Service Tools

NBS004QM

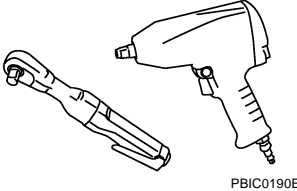
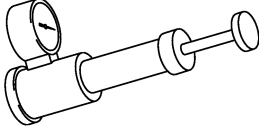
Tool name	Description
<p data-bbox="140 261 252 285">Power tool</p>  <p data-bbox="836 463 908 480">PBIC0190E</p>	<p data-bbox="997 261 1254 285">Loosening nuts and bolts</p>
<p data-bbox="140 502 336 525">Radiator cap tester</p>  <p data-bbox="836 697 908 715">PBIC1982E</p>	<p data-bbox="997 502 1350 525">Checking radiator and radiator cap</p>

OVERHEATING CAUSE ANALYSIS

[VQ35DE]

OVERHEATING CAUSE ANALYSIS

PFP:00012

Troubleshooting Chart

NBS004QN

	Symptom		Check items		
Cooling system parts malfunction	Poor heat transfer	Water pump malfunction	Worn or loose drive belt	—	
		Thermostat stuck closed	—		
		Damaged fins	Dust contamination or paper clogging		
			Physical damage		
		Clogged radiator cooling tube	Excess foreign material (rust, dirt, sand, etc.)		
	Reduced air flow	Cooling fan does not operate	Fan assembly	—	
		High resistance to fan rotation			
		Damaged fan blades			
		Damaged radiator shroud	—	—	
		Improper engine coolant mixture ratio	—	—	
		Poor engine coolant quality	—	Engine coolant density	—
	Insufficient engine coolant	Engine coolant leaks	Cooling hose	Loose clamp	
				Cracked hose	
			Water pump	Poor sealing	
			Radiator cap	Loose	
Poor sealing					
Radiator			O-ring for damage, deterioration or improper fitting		
		Cracked radiator tank			
		Cracked radiator core			
	Reservoir tank	Cracked reservoir tank			
Overflowing reservoir tank	Exhaust gas leaks into cooling system	Cylinder head deterioration			
		Cylinder head gasket deterioration			

A
CO
C
D
E
F
G
H
I
J
K
L
M

OVERHEATING CAUSE ANALYSIS

[VQ35DE]

	Symptom		Check items			
Except cooling system parts malfunction	—	Overload on engine	Abusive driving	High engine rpm under no load		
				Driving in low gear for extended time		
				Driving at extremely high speed		
					Powertrain system malfunction	—
					Installed improper size wheels and tires	
					Dragging brakes	
			Improper ignition timing			
	Blocked or restricted air flow	Blocked bumper	—	—		
		Blocked radiator grille	Installed car brassiere			
			Mud contamination or paper clogging			
Blocked radiator		—				
Blocked condenser		Blocked air flow				
Installed large fog lamp						

COOLING SYSTEM

[VQ35DE]

COOLING SYSTEM

PFP:21020

Cooling Circuit

NBS00400

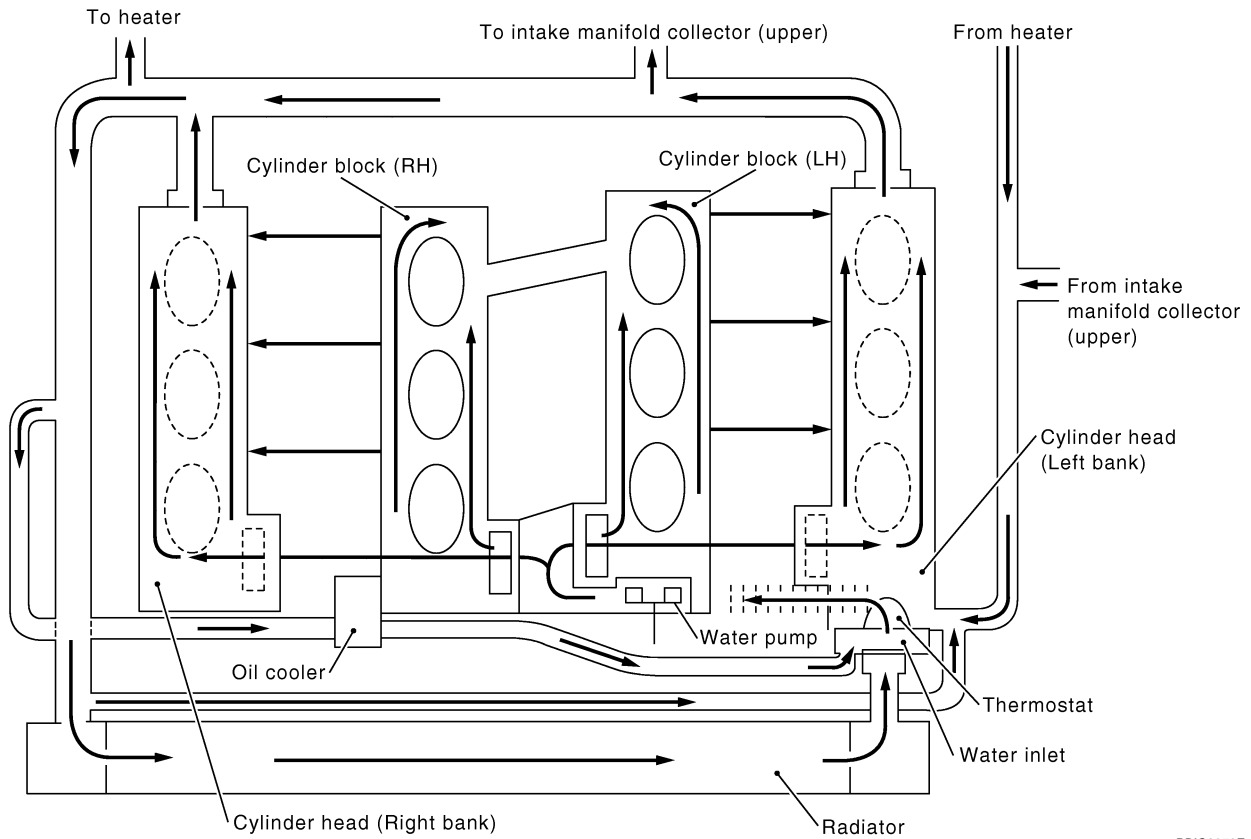

PBIC2073E

A
CO
C
D
E
F
G
H
I
J
K
L
M

COOLING SYSTEM

[VQ35DE]

System Chart

NBS004QP

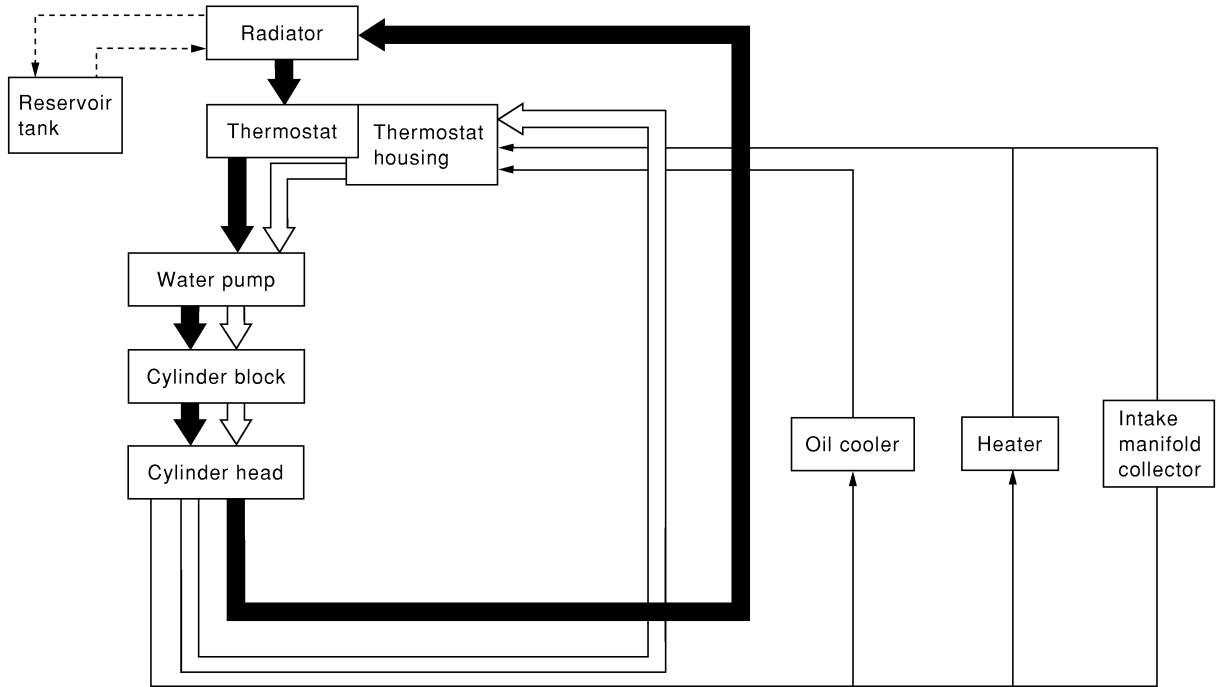

	Thermostat
	Closed
	Open

PBIC0847E

ENGINE COOLANT

PFP:KQ100

NBS004QQ

Inspection LEVEL CHECK

- Check if the reservoir tank engine coolant level is within the "MIN" to "MAX" when the engine is cool.
- Adjust the engine coolant level as necessary.

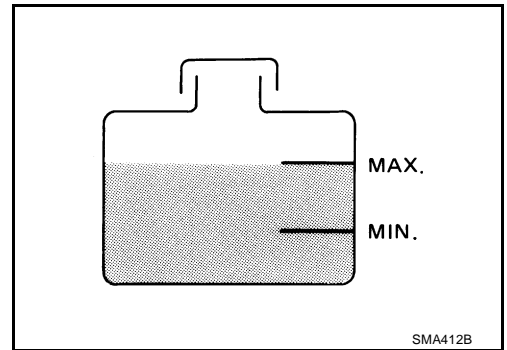

LEAK CHECK

- To check for leaks, apply pressure to the cooling system with the radiator cap tester (commercial service tool) and radiator cap tester adapter (SST).

Testing pressure

: 157 kPa (1.6 kg/cm² , 23 psi)

WARNING:

Do not remove radiator cap when engine is hot. Serious burns could occur from high-pressure engine coolant escaping from radiator.

CAUTION:

Higher test pressure than specified may cause radiator damage.

NOTE:

In a case that engine coolant decreases, replenish radiator with engine coolant.

- If anything is found, repair or replace damaged parts.

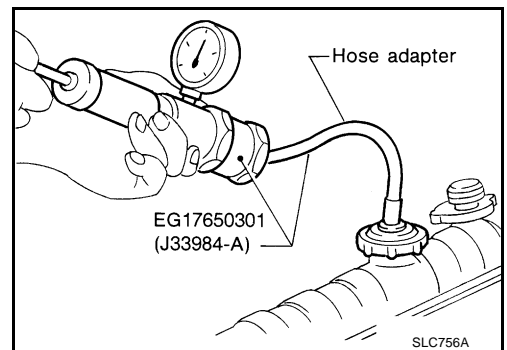

Changing Engine Coolant

NBS004QR

WARNING:

- To avoid being scalded, do not change engine coolant when the engine is hot.
- Wrap a thick cloth around radiator cap and carefully remove radiator cap. First, turn radiator cap a quarter of a turn to release built-up pressure. Then turn radiator cap all the way.

DRAINING ENGINE COOLANT

1. Remove engine room cover (RH and LH). Refer to [EM-14, "ENGINE ROOM COVER"](#) .
2. Remove air duct (inlet). Refer to [EM-17, "AIR CLEANER AND AIR DUCT"](#) .
3. Open radiator drain plug at the bottom of radiator, and then remove radiator cap.

- 1 : Radiator drain plug hole
- 2 : Front engine under cover
- ↔ : Engine front

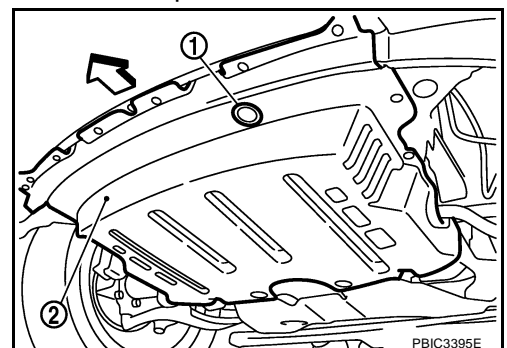

When draining all of engine coolant in the system, open water drain plugs on cylinder block. Refer to [EM-124, "DISASSEMBLY"](#) .

4. Remove reservoir tank as necessary, and drain engine coolant and clean reservoir tank before installing.
5. Check drained engine coolant for contaminants such as rust, corrosion or discoloration. If contaminated, flush the engine cooling system. Refer to [CO-13, "FLUSHING COOLING SYSTEM"](#).

REFILLING ENGINE COOLANT

1. Install reservoir tank if removed, and radiator drain plug.

CAUTION:

Be sure to clean drain plug and install with new O-ring.

Radiator drain plug:

 : 1.2 N·m (0.12 kg·m, 11 in·lb)

If water drain plugs on cylinder block are removed, close and tighten them. Refer to [EM-128, "ASSEMBLY"](#).

2. Make sure that each hose clamp has been firmly tightened.
3. Remove air relief plug on heater hose.

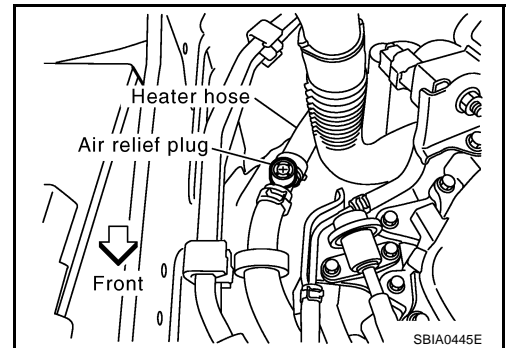

4. Fill radiator, and reservoir tank if removed, to specified level.
 - Pour engine coolant through engine coolant filler neck slowly of less than 2 ℓ (2-1/8 US qt, 1-3/4 Imp qt) a minute to allow air in system to escape.
 - Use Genuine Nissan Long Life Antifreeze/Coolant or equivalent mixed with water (distilled or demineralized). Refer to [MA-12, "RECOMMENDED FLUIDS AND LUBRICANTS"](#).

**Engine coolant capacity
(With reservoir tank at "MAX" level)**

: Approximately 8.9 ℓ (9-3/8 US qt, 7-7/8 Imp qt)

**Reservoir tank engine coolant capacity
(At "MAX" level)**

: 0.6 ℓ (5/8 US qt, 1/2 Imp qt)

- When engine coolant overflows air relief hole on heater hose, install air relief plug with new O-ring.

Air relief plug:

 : 1.2 N·m (0.12 kg·m, 11 ft·lb)

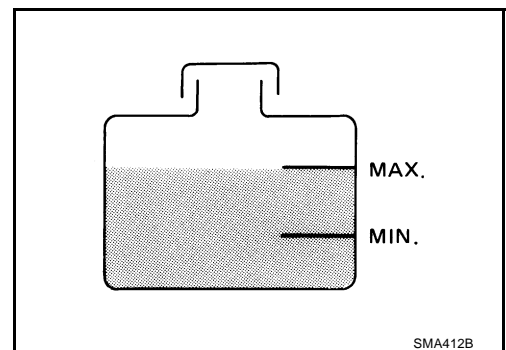
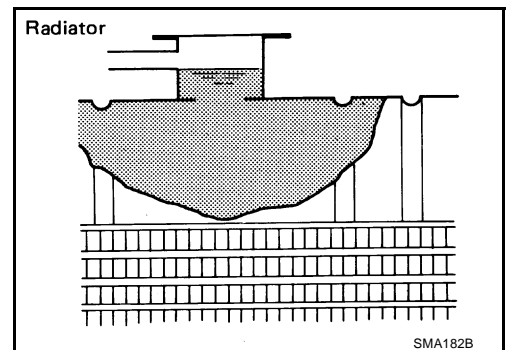

5. Install radiator cap.
6. Warm up engine until opening thermostat. Standard for warming-up time is approximately 10 minutes at 3,000 rpm.
 - Make sure thermostat opening condition by touching radiator hose (lower) to see a flow of warm water.

CAUTION:

Watch water temperature gauge so as not to overheat engine.

7. Stop the engine and cool down to less than approximately 50°C (122°F).
 - Cool down using fan to reduce the time.
 - If necessary, refill radiator up to filler neck with engine coolant.
8. Refill reservoir tank to "MAX" level line with engine coolant.
9. Repeat steps 4 through 7 two or more times with radiator cap installed until engine coolant level no longer drops.
10. Check cooling system for leaks with engine running.
11. Warm up the engine, and check for sound of engine coolant flow while running engine from idle up to 3,000 rpm with heater temperature controller set at several position between "COOL" and "WARM".
 - Sound may be noticeable at heater unit.
12. Repeat step 11 three times.
13. If sound is heard, bleed air from cooling system by repeating step 4 through 7 until engine coolant level no longer drops.

FLUSHING COOLING SYSTEM

1. Install reservoir tank if removed, and radiator drain plug.

CAUTION:

Be sure to clean drain plug and install with new O-ring.

Radiator drain plug:

 : 1.2 N·m (0.12 kg-m, 11 in-lb)

If water drain plugs on cylinder block are removed, close and tighten them. Refer to [EM-128, "ASSEMBLY"](#).

2. Remove air relief plug on heater hose.

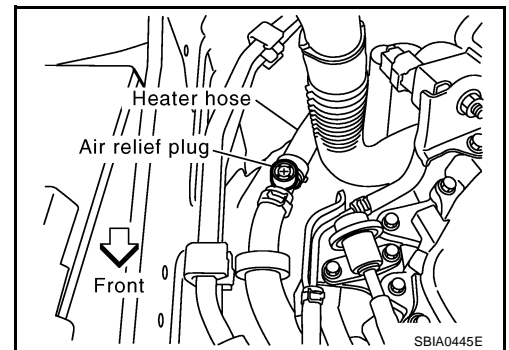

3. Fill radiator with water until water spills from the air relief hole, then close air relief plug. Fill radiator and reservoir tank with water and reinstall radiator cap.

Air relief plug:

 : 1.2 N·m (0.12 kg-m, 11 ft-lb)

4. Run the engine and warm it up to normal operating temperature.
5. Rev the engine two or three times under no-load.
6. Stop the engine and wait until it cools down.
7. Drain water from the system. Refer to [CO-11, "DRAINING ENGINE COOLANT"](#).
8. Repeat steps 1 through 7 until clear water begins to drain from radiator.

RADIATOR

PFP:21400

Components

NBS004QS

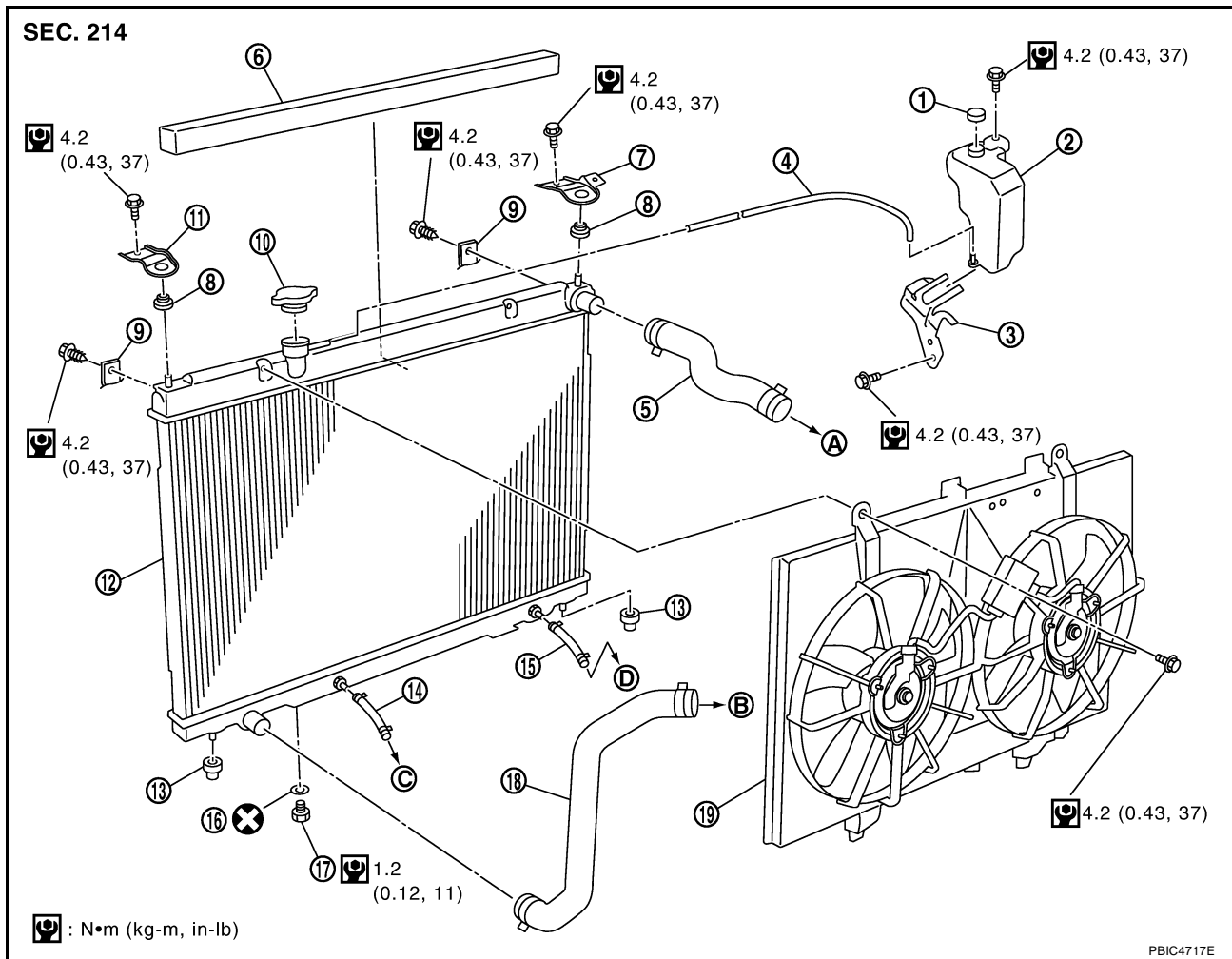

- | | | |
|-----------------------------|----------------------------|---------------------------|
| 1. Reservoir tank cap | 2. Reservoir tank | 3. Reservoir tank bracket |
| 4. Reservoir tank hose | 5. Radiator hose (upper) | 6. Air guide |
| 7. Mount bracket (RH) | 8. Mounting rubber (upper) | 9. A/C condenser |
| 10. Radiator cap | 11. Mount bracket (LH) | 12. Radiator |
| 13. Mounting rubber (lower) | 14. A/T fluid cooler hose | 15. A/T fluid cooler hose |
| 16. O-ring | 17. Drain plug | 18. Radiator hose (lower) |
| 19. Cooling fan assembly | | |
| A. To water outlet | B. To water inlet | C. To transmission |
| D. To transmission | | |

- Refer to [GI-11, "Components"](#) for symbol marks in the figure.

Removal and Installation

NBS004QT

WARNING:

Do not remove radiator cap when engine is hot. Serious burns could occur from high-pressure engine coolant escaping from radiator. Wrap a thick cloth around the cap. Slowly turn it a quarter of a turn to release built-up pressure. Carefully remove radiator cap by turning it all the way.

REMOVAL

- Remove the following parts:
 - Front engine undercover (power tool).
 - Engine room cover (RH and LH). Refer to [EM-14, "ENGINE ROOM COVER"](#).
 - Air duct (inlet) and air cleaner case assembly. Refer to [EM-17, "AIR CLEANER AND AIR DUCT"](#).

2. Remove front grille and front grille support. Refer to [EI-16, "FRONT GRILLE"](#).

NOTE:

If stopping at the removal and installation of the cooling fan assembly, this procedure is not necessary.

3. Drain engine coolant from radiator. Refer to [CO-11, "Changing Engine Coolant"](#).

CAUTION:

- Perform this step when the engine is cold.
- Do not spill engine coolant on drive belts.

4. Remove the A/C piping bracket from left side member, and then move the A/C piping out of the way.

5. Disconnect A/T fluid cooler hoses from radiator.

- Install blind plug to avoid leakage of A/T fluid.

6. Remove radiator hoses (upper and lower) and reservoir tank hose.

CAUTION:

Be careful not to allow engine coolant to contact drive belts.

7. Remove cooling fan assembly (1). Refer to [CO-22, "COOLING FAN"](#).

CAUTION:

Do not damage or scratch radiator core when removing.

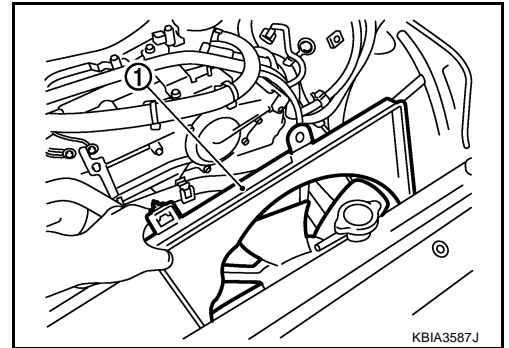

8. Remove radiator as follows:

- a. Remove mount bracket (RH and LH).

- b. Pull the radiator (1) rearward from the vehicle, and then remove the mounting bolts (3) and A/C condenser (2).

NOTE:

Figure shows right side.

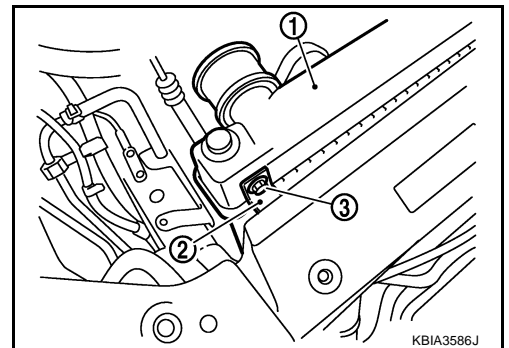

- c. Lift up and pull the radiator (4) rearward, and then remove the mounting rubber (lower) (3) from the radiator core support (2).

1 : A/C condenser

⇐ : Engine front

CAUTION:

At this time, A/C condenser is on the lower end of radiator front surface. Minimize the movement to the rear side.

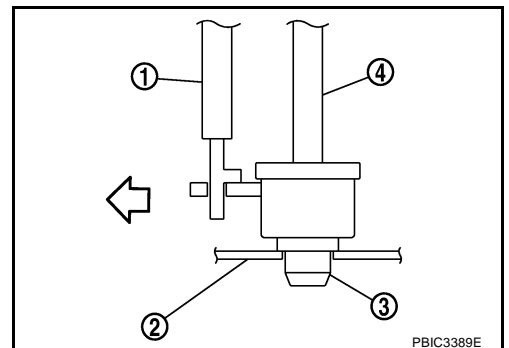

- d. Lift up the A/C condenser to disengage the lower end of front surface, and then remove the radiator.

CAUTION:

- Be careful not to damage radiator and A/C condenser core.

- Minimize the lift of A/C condenser to prevent load from being applied to A/C piping.

e. After removing the radiator, place the A/C condenser on the radiator core support to prevent load from being applied to piping. And then, temporarily secure them using a rope to prevent them from being dropped.

INSTALLATION

Installation is the reverse order of removal.

INSPECTION AFTER INSTALLATION

- Check for leaks of engine coolant using the radiator cap tester adapter [SST: EG17650301 (J33984-A)] and the radiator cap tester (commercial service tool). Refer to [CO-11, "LEAK CHECK"](#).
- Start and warm up the engine. Visually make sure that there is no leaks of engine coolant and A/T fluid.

Checking Radiator Cap

- Check valve seat of radiator cap.
 - Check if valve seat is swollen to the extent that the edge of the plunger cannot be seen when watching it vertically from the top.
 - Check if valve seat has no soil and damage.

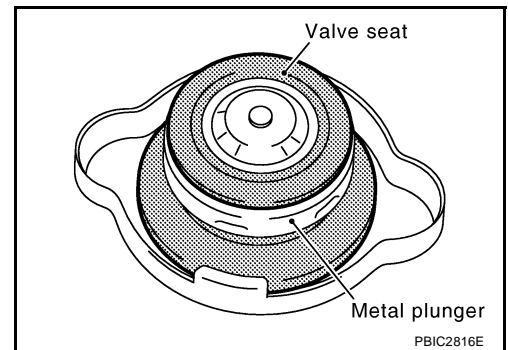

- Pull negative-pressure valve to open it, and make sure that it close completely when released.
 - Make sure that there is no dirt or damage on the valve seat of radiator cap negative-pressure valve.
 - Make sure that there are no unusualness in the opening and closing conditions of negative-pressure valve.

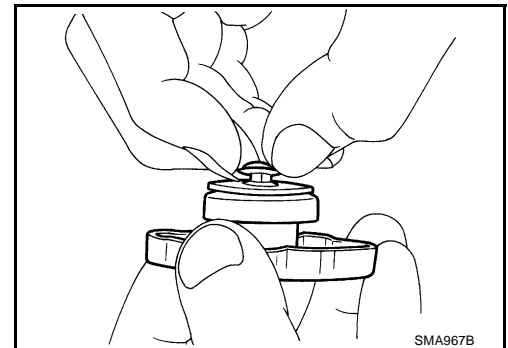

- Check radiator cap relief pressure.

Standard:

78 - 98 kPa (0.8 - 1.0 kg/cm² , 11 - 14 psi)

Limit:

59 kPa (0.6 kg/cm² , 9 psi)

- When connecting radiator cap to the radiator cap tester (commercial service tool) and the radiator cap tester adapter (SST), apply engine coolant to the cap seal surface.

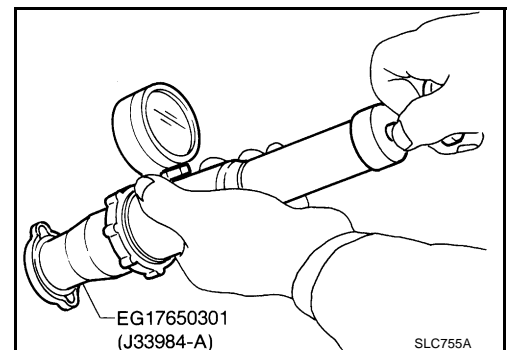

- Replace radiator cap if there is an unusualness related to the above three.

CAUTION:

When installing radiator cap, thoroughly wipe out the radiator filler neck to remove any waxy residue or foreign material.

Checking Radiator

Check radiator for mud or clogging. If necessary, clean radiator as follows.

- Be careful not to bend or damage radiator fins.

RADIATOR

[VQ35DE]

- When radiator is cleaned without removal, remove all surrounding parts such as radiator cooling fan assembly and horns. Then tape harness and connectors to prevent water from entering.
- 1. Apply water by hose to the back side of the radiator core vertically downward.
- 2. Apply water again to all radiator core surfaces once per minute.
- 3. Stop washing if any stains no longer flow out from radiator.
- 4. Blow air into the back side of radiator core vertically downward.
 - Use compressed air lower than 490 kPa (5 kg/cm² , 71 psi) and keep distance more than 30 cm (11.8 in).
- 5. Blow air again into all the radiator core surfaces once per minute until no water sprays out.

A

CO

C

D

E

F

G

H

I

J

K

L

M

RADIATOR (ALUMINUM TYPE)

PFP:21460

Components

NBS004QW

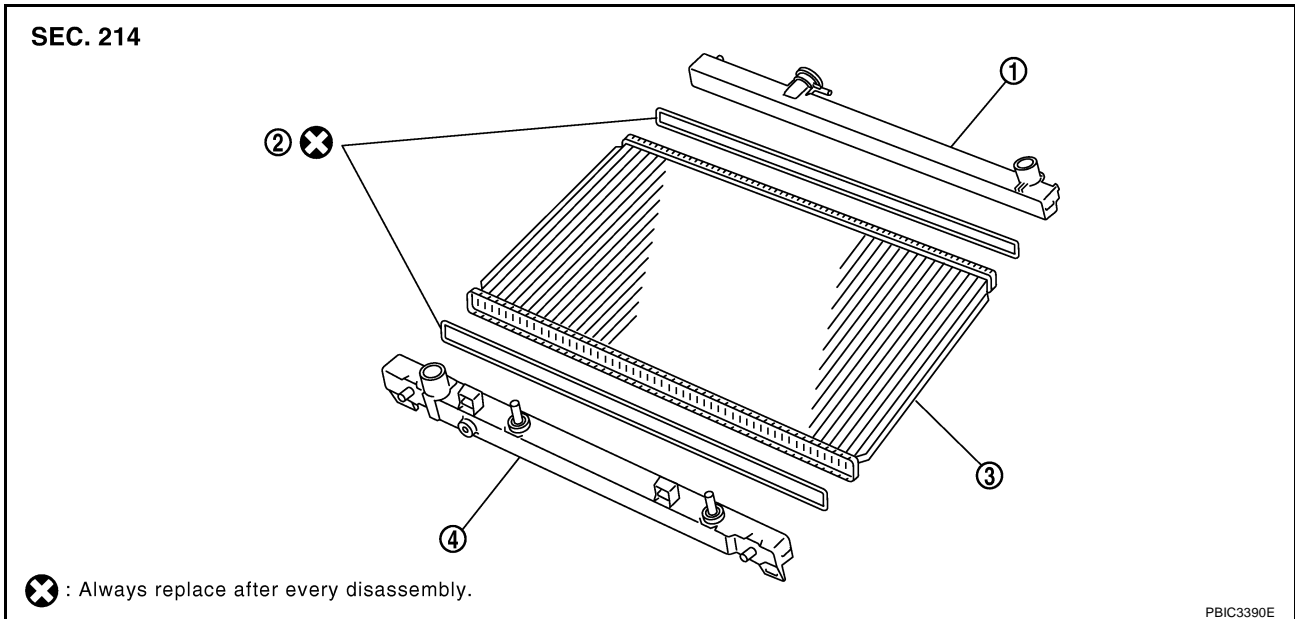

1. Upper tank
2. Sealing rubber
3. Core
4. Lower tank (with A/T fluid cooler)

Disassembly and Assembly PREPARATION

NBS004QX

1. Attach spacer to tip of the radiator plate pliers A (SST).
Spacer specification: 18 mm (0.71 in) wide × 8.5 mm (0.335 in) long × 1.5 mm (0.059 in) thick.

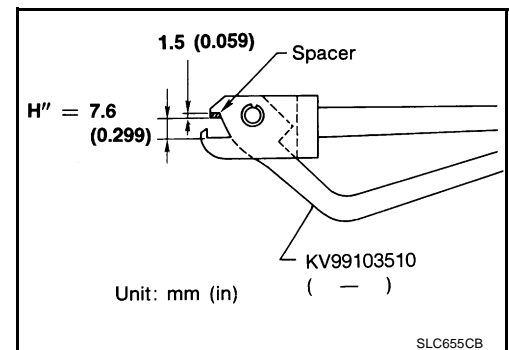

2. Make sure that when the radiator plate pliers A [SST: KV99103510 (—)] are closed dimension H'' is approx. 7.6 mm (0.299 in).
3. Adjust dimension H'' with spacer, if necessary.

DISASSEMBLY

1. Remove upper and lower tanks with the radiator plate pliers B (SST).

CAUTION:

Do not disassemble lower tank and A/T fluid cooler.

NOTE:

Regard lower tank and A/T fluid cooler as an assembly.

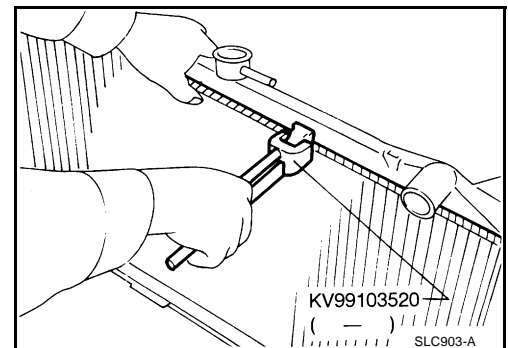

RADIATOR (ALUMINUM TYPE)

[VQ35DE]

- Grip the crimped edge and bend it upwards so that the radiator plate pliers B slips off.

CAUTION:

Do not bend excessively.

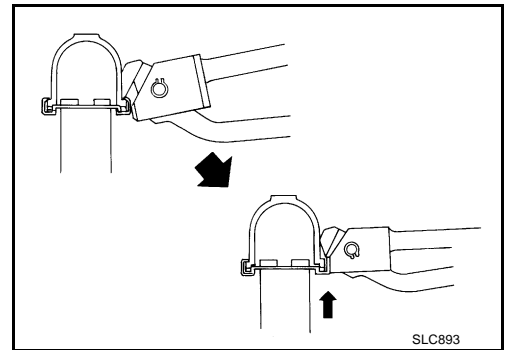

- In areas where the radiator plate pliers B cannot be used, use a screwdriver to bend the edge up.

CAUTION:

Be careful not to damage tank.

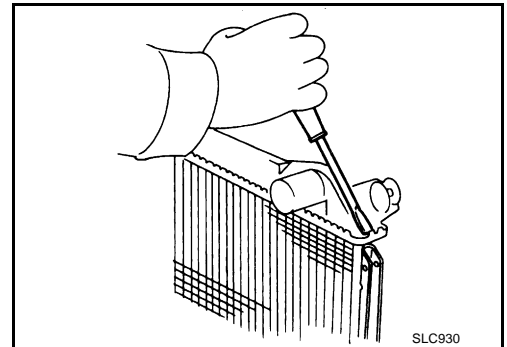

2. Remove sealing rubber.
3. Make sure the edge stands straight up.

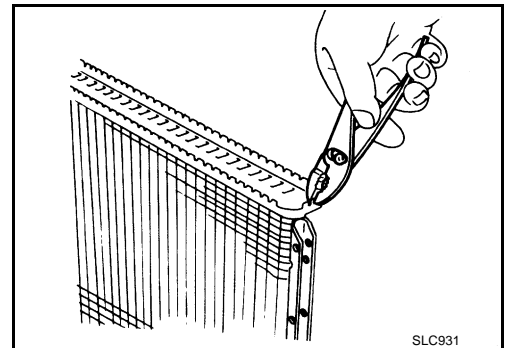

ASSEMBLY

1. Clean contact portion of tank.

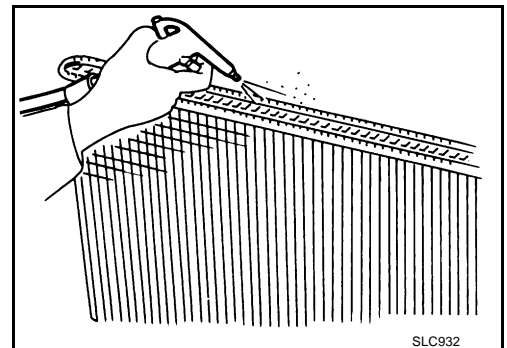

A
CO
C
D
E
F
G
H
I
J
K
L
M

RADIATOR (ALUMINUM TYPE)

[VQ35DE]

2. Install new sealing rubber while pushing it with fingers.

CAUTION:
Be careful not to twist sealing rubber.

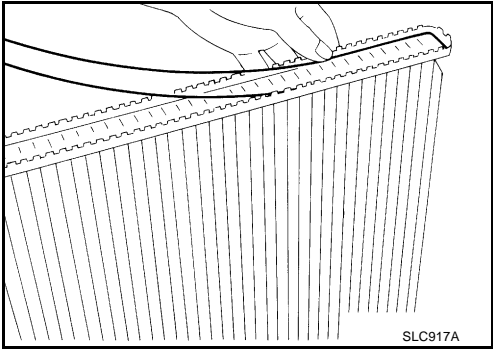

3. Caulk tank in numerical order as shown in the figure with the radiator plate pliers A (SST).

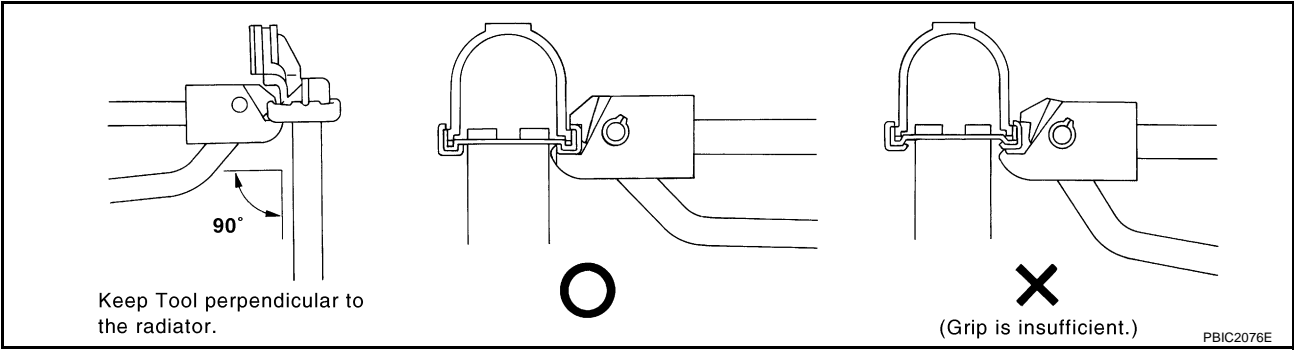
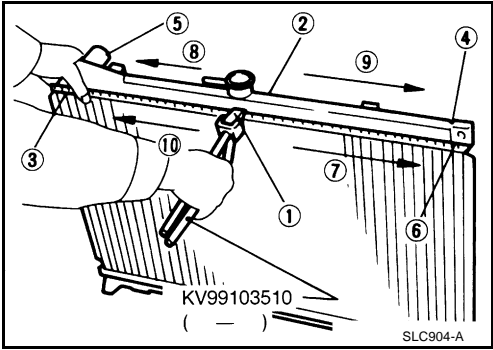

● Use pliers in the locations where the radiator plate pliers A cannot be used.

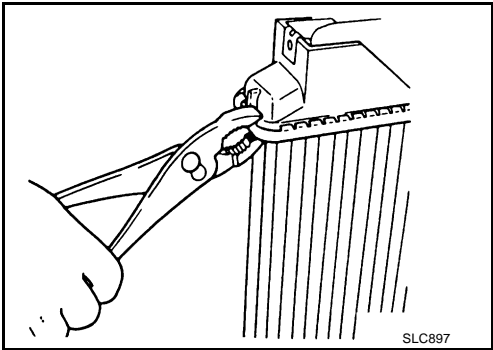

RADIATOR (ALUMINUM TYPE)

[VQ35DE]

4. Make sure that the rim is completely crimped down.

Standard height "H" : 8.0 - 8.4 mm (0.315 - 0.331 in)

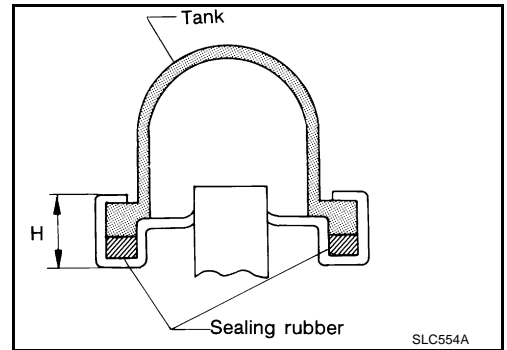

5. Make sure that there is no leakage. Refer to [CO-21, "INSPECTION"](#).

INSPECTION

1. Apply pressure with the radiator cap tester adapter (SST) and the radiator cap tester (commercial service tool).

Testing pressure

: 157 kPa (1.6 kg/cm² , 23 psi)

WARNING:

To prevent the risk of hose coming undone while under pressure, securely fasten it down with hose clamp.

CAUTION:

Attach hose to A/T fluid cooler to seal its inlet and outlet.

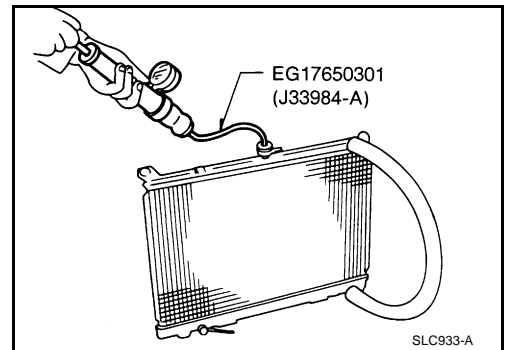

2. Check for leakage by soaking radiator in water container with the testing pressure applied.

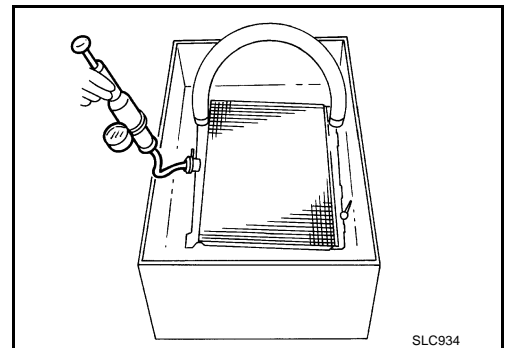

A
CO
C
D
E
F
G
H
I
J
K
L
M

COOLING FAN

PFP:21140

Components

NBS004QY

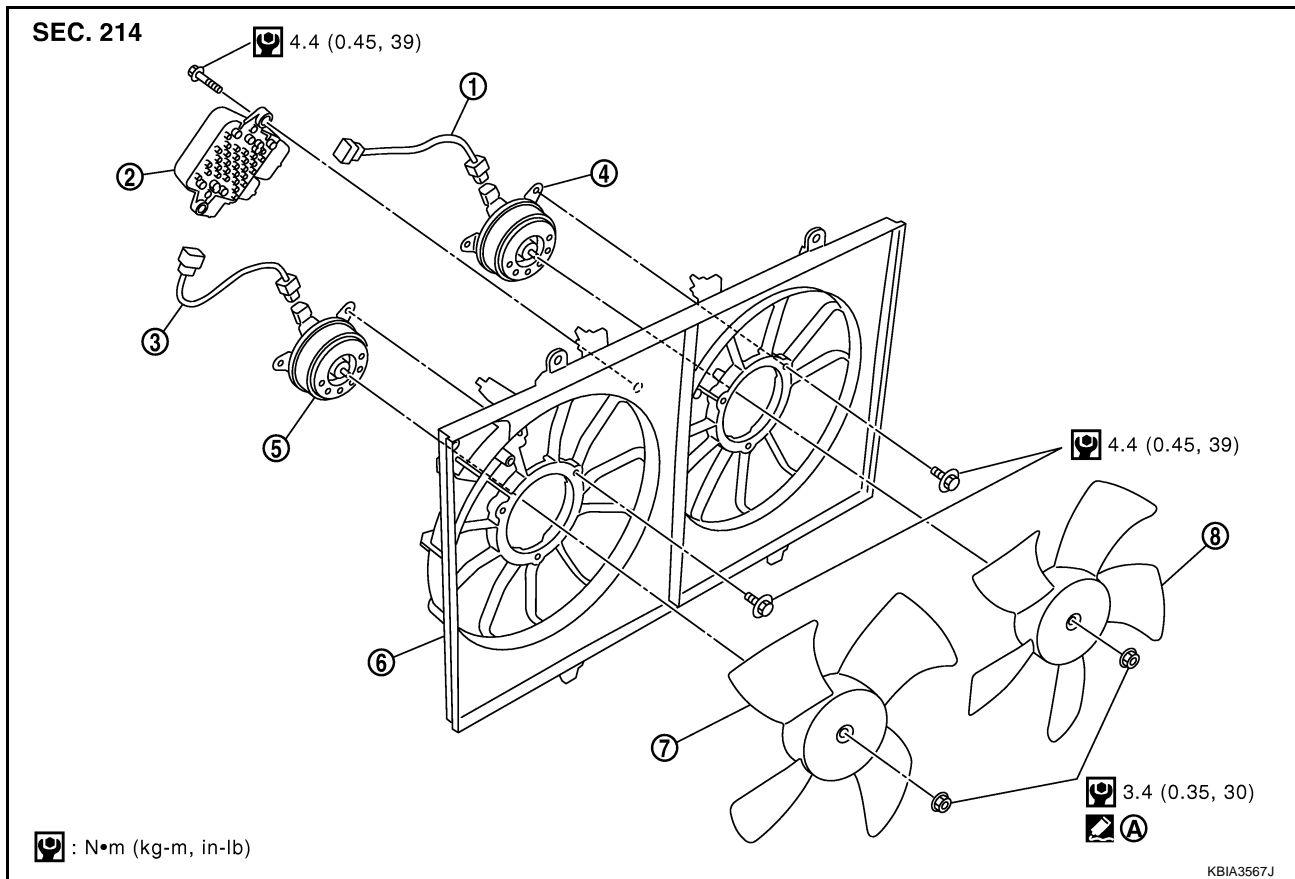

- | | | |
|---------------------|-------------------------------|----------------|
| 1. Sub-harness | 2. Cooling fan control module | 3. Sub-harness |
| 4. Fan motor (LH) | 5. Fan motor (RH) | 6. Fan shroud |
| 7. Cooling fan (RH) | 8. Cooling fan (LH) | |

A. Apply on fan motor shaft.

Apply Genuine High Strength Locking Sealant or equivalent.

Removal and Installation

REMOVAL

NBS004QZ

- Remove engine room cover (RH and LH). Refer to [EM-14, "ENGINE ROOM COVER"](#).
- Remove air duct (inlet) and air cleaner case assembly. Refer to [EM-17, "AIR CLEANER AND AIR DUCT"](#).
- Drain engine coolant from radiator. Refer to [CO-11, "ENGINE COOLANT"](#).
- Disconnect harness connector from cooling fan control module, and move harness to aside.
- Remove radiator hose (upper). Refer to [CO-14, "RADIATOR"](#).
- Remove cooling fan assembly.

CAUTION:

Be careful not to damage or scratch on radiator core.

INSTALLATION

Note the following, and install in the reverse order of removal.

CAUTION:

Only use genuine parts for radiator shroud and cooling fan mounting bolt and observe the specified torque (to prevent radiator from being damaged).

INSPECTION AFTER INSTALLATION

Make sure that fan motors operate normally.

NOTE:

Cooling fans are controlled by cooling fan control module. For details, refer to [EC-512, "DTC P1217 ENGINE OVER TEMPERATURE"](#).

Disassembly and Assembly
DISASSEMBLY

NBS004R0

CO

1. Disconnect sub-harness from fan motor (RH and LH) and cooling fan control module.
2. Remove cooling fan control module from fan shroud.

CAUTION:

Handle carefully to avoid dropping and shocks.

3. Remove cooling fan mounting nuts, and then remove the cooling fan (RH and LH).
4. Remove fan motor (RH and LH).

INSPECTION AFTER DISASSEMBLY**Cooling Fan**

Inspect cooling fan for crack or unusual bend.

- If anything is found, replace cooling fan.

ASSEMBLY

Note the following, and assemble in the reverse order of disassembly.

CAUTION:

RH and LH cooling fans are different. Be careful not to misassemble them.

- Install each fan in the following position.

Right side : 4 fans

Left side : 5 fans

- Secure the sub-harness tightly to the fan shroud to prevent the fan rotation area from being loose.

WATER PUMP

PFP:21020

Components

NBS004R1

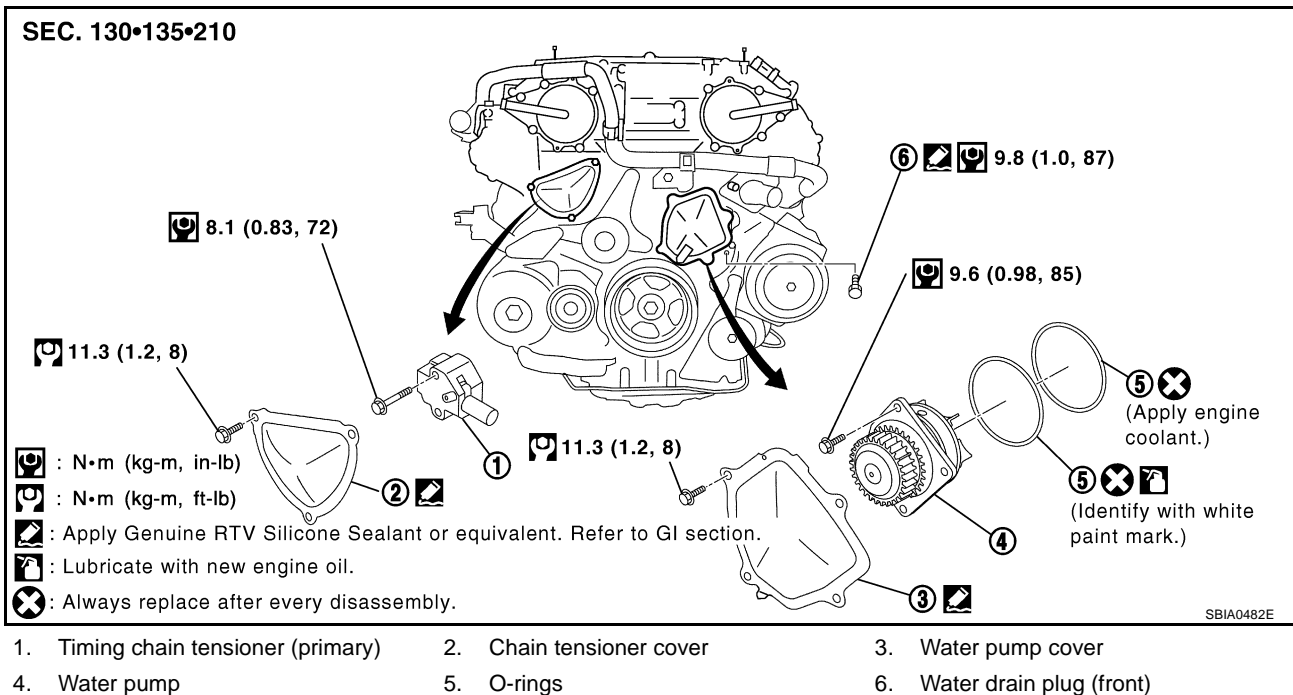

Removal and Installation

NBS004R2

CAUTION:

- When removing water pump assembly, be careful not to get engine coolant on drive belts.
- Water pump cannot be disassembled and should be replaced as a unit.
- After installing water pump, connect hose and clamp securely, then check for leaks using the radiator cap tester (commercial service tool) and the radiator cap tester adapter [SST: EG17650301 (J33984-A)].

REMOVAL

1. Remove engine room cover (RH and LH). Refer to [EM-14, "ENGINE ROOM COVER"](#).
2. Remove air duct (inlet) and air cleaner case assembly. Refer to [EM-17, "AIR CLEANER AND AIR DUCT"](#).
3. Remove front engine undercover with power tool.
4. Remove drive belts. Refer to [EM-15, "DRIVE BELTS"](#).
5. Drain engine coolant from radiator. Refer to [CO-11, "Changing Engine Coolant"](#).

CAUTION:

- Perform this step when the engine is cold.
 - Do not spill engine coolant on drive belts.
6. Remove water drain plug (front) on water pump side of cylinder block to drain engine coolant from engine inside.

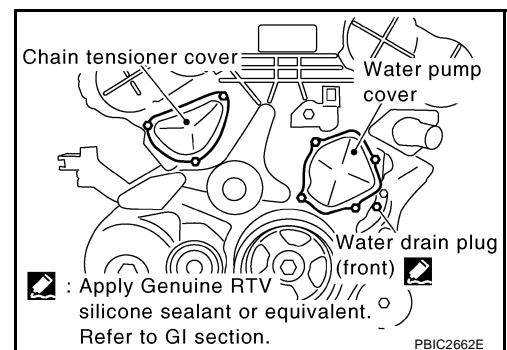

7. Remove chain tensioner cover and water pump cover from front timing chain case.

WATER PUMP

[VQ35DE]

- Use the seal cutter [SST: KV10111100 (J37228)] to cut liquid gasket for removal.

8. Remove timing chain tensioner (primary) as follows:

a. Remove lower mounting bolt.

CAUTION:

Be careful not to drop mounting bolt inside timing chain case.

b. Loosen upper mounting bolt slowly, and then turn chain tensioner (primary) on the mounting bolt so that plunger is fully expanded.

NOTE:

Even if plunger is fully expanded, it is not dropped from the body of timing chain tensioner (primary).

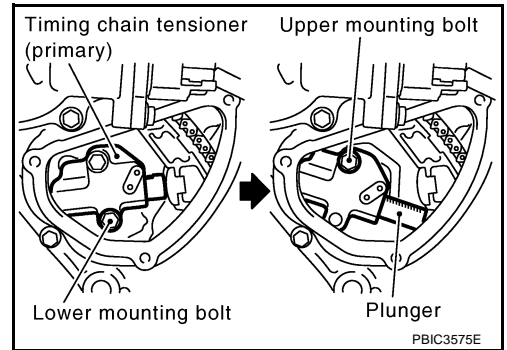

c. Turn crankshaft pulley clockwise so that timing chain on the timing chain tensioner (primary) side is loose.

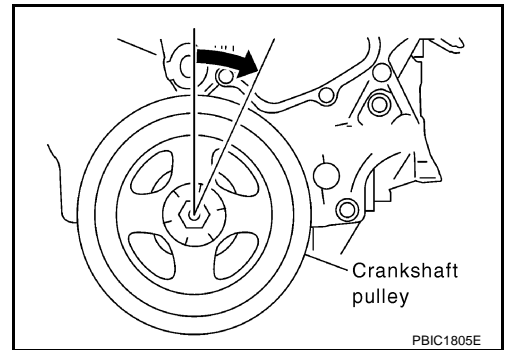

d. Remove upper mounting bolt, and then remove timing chain tensioner (primary).

CAUTION:

Be careful not to drop mounting bolt inside timing chain case.

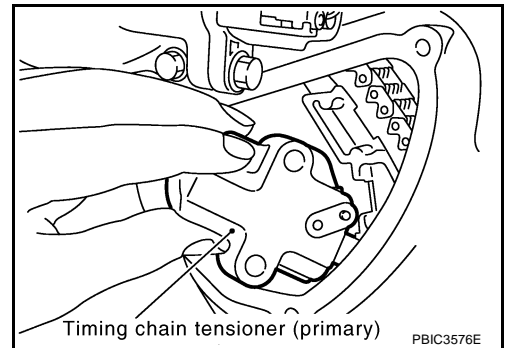

9. Remove water pump as follows:

a. Remove three water pump mounting bolts. Secure a gap between water pump gear and timing chain, by turning crankshaft pulley counterclockwise until timing chain looseness on water pump sprocket becomes maximum.

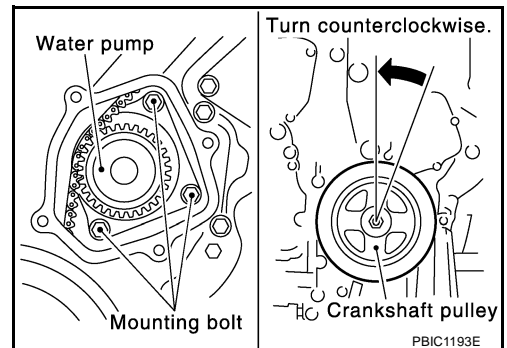

A
CO
C
D
E
F
G
H
I
J
K
L
M

WATER PUMP

[VQ35DE]

- b. Screw M8 bolts [pitch: 1.25 mm (0.049 in) length: approx. 50 mm (1.97 in)] into water pumps upper and lower mounting bolt holes until they reach timing chain case. Then, alternately tighten each bolt for a half turn, and pull out water pump.

CAUTION:

- Pull straight out while preventing vane from contacting socket in installation area.
- Remove water pump without causing sprocket to contact timing chain.

- c. Remove M8 bolts and O-rings from water pump.

CAUTION:

Do not disassemble water pump.

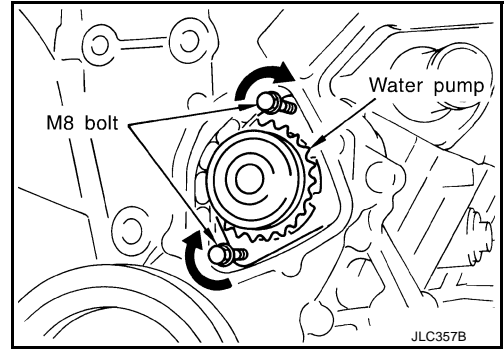

INSPECTION AFTER REMOVAL

- Check for badly rusted or corroded water pump body assembly.
- Check for rough operation due to excessive end play.
- If anything is found, replace water pump.

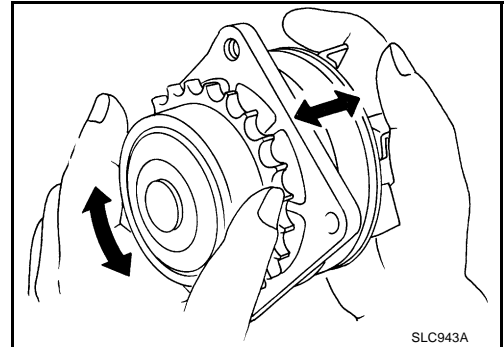

INSTALLATION

1. Install new O-rings to water pump.
- Apply engine oil and engine coolant to O-rings as shown in the figure.
 - Locate O-ring with white paint mark to engine front side.

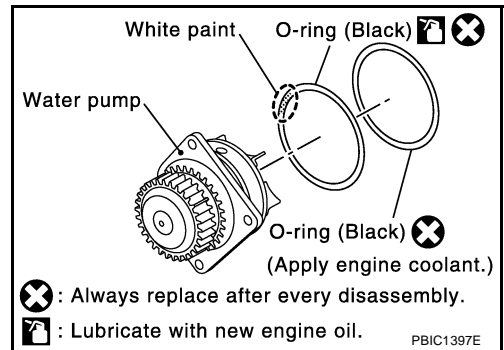

2. Install water pump.

CAUTION:

Do not allow cylinder block to nip O-rings when installing water pump.

- Make sure timing chain and water pump sprocket are engaged.
- Insert water pump by tightening mounting bolts alternately and evenly.

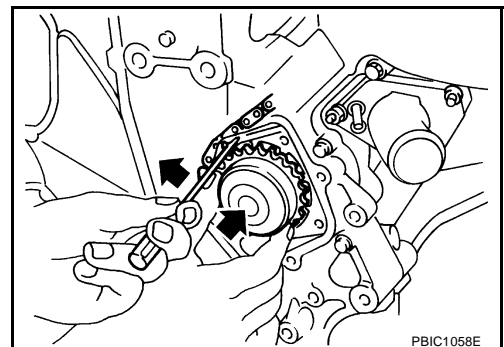

3. Install timing chain tensioner (primary) as follows:

WATER PUMP

[VQ35DE]

- a. Turn crankshaft pulley clockwise so that timing chain on the timing chain tensioner (primary) side is loose.

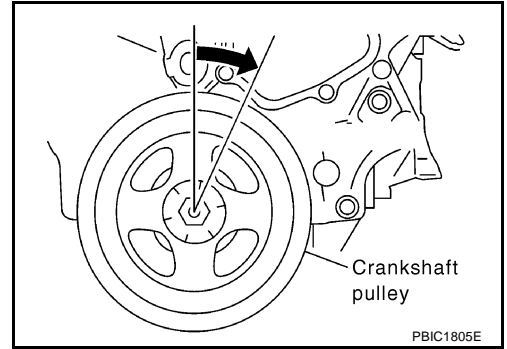

- b. Pull plunger stopper tab up (or turn lever downward) so as to remove plunger stopper tab from the ratchet of plunger.

NOTE:

Plunger stopper tab and lever are synchronized.

- c. Push plunger into the inside of tensioner body.
- d. Hold plunger in the fully compressed position by engaging plunger stopper tab with the tip of ratchet.
- e. To secure lever, insert stopper pin through hole of lever into tensioner body hole.
- The lever parts and the tab are synchronized. Therefore, the plunger will be secured under this condition.

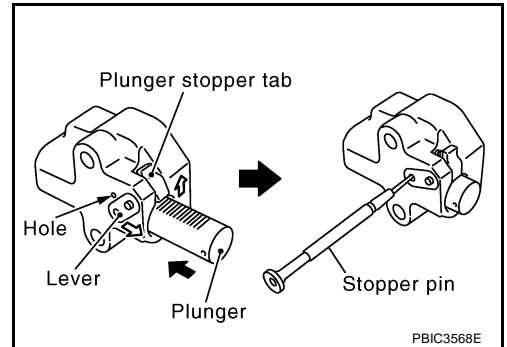

NOTE:

Figure shows the example of 1.2 mm (0.047 in) diameter thin screwdriver being used as the stopper pin.

- f. Install timing chain tensioner (primary).
- Remove dust and foreign material completely from backside of timing chain tensioner (primary) and from installation area of rear timing chain case.
- g. Remove stopper pin.

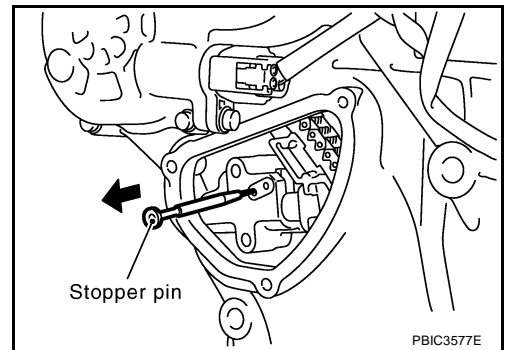

- h. Make sure again that timing chain and water pump sprocket are engaged.

4. Install chain tensioner cover and water pump cover as follows:

- a. Before installing, remove all traces of old liquid gasket from mating surface of water pump cover and chain tensioner cover using scraper. Also remove traces of old liquid gasket from the mating surface of front timing chain case.

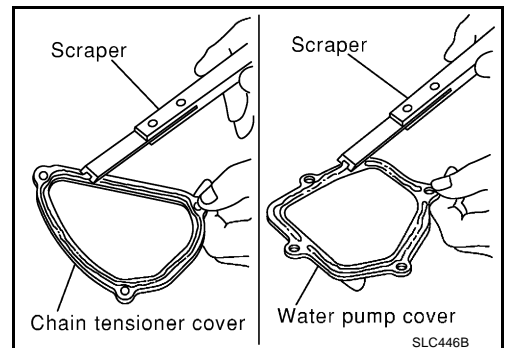

WATER PUMP

[VQ35DE]

- b. Apply a continuous bead of liquid gasket with tube presser [SST: WS39930000 (—)] to mating surface of chain tensioner cover and water pump cover.

Use Genuine RTV Silicone Sealant or equivalent. Refer to [GI-48, "RECOMMENDED CHEMICAL PRODUCTS AND SEALANTS"](#) .

CAUTION:

Attaching should be done within 5 minutes after coating.

- c. Tighten mounting bolts.

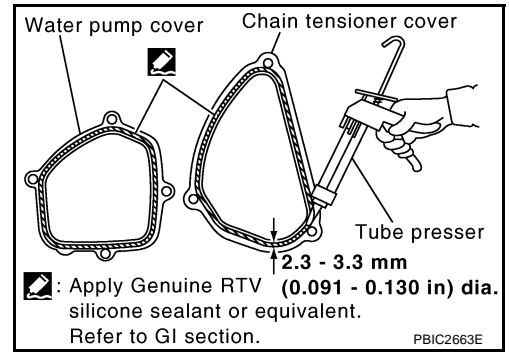

5. Install water drain plug (front) on water pump side of cylinder block.

- Apply liquid gasket to the thread of water drain plug (front).

Use Genuine RTV Silicone Sealant or equivalent. Refer to [GI-48, "RECOMMENDED CHEMICAL PRODUCTS AND SEALANTS"](#) .

6. Install in the reverse order of removal for remaining parts.

- **After starting engine, let idle for three minutes, then rev engine up to 3,000 rpm under no load to purge air from the high-pressure chamber of chain tensioner. Engine may produce a rattling noise. This indicates that air still remains in the chamber and is not a matter of concern.**

INSPECTION AFTER INSTALLATION

- Check for leaks of engine coolant using the radiator cap tester adapter [SST: EG17650301 (J33984-A)] and the radiator cap tester (commercial service tool). Refer to [CO-11, "LEAK CHECK"](#) .
- Start and warm up the engine. Visually make sure that there is no leaks of engine coolant.

WATER INLET AND THERMOSTAT ASSEMBLY

PFP:21200

Components

NBS004R3

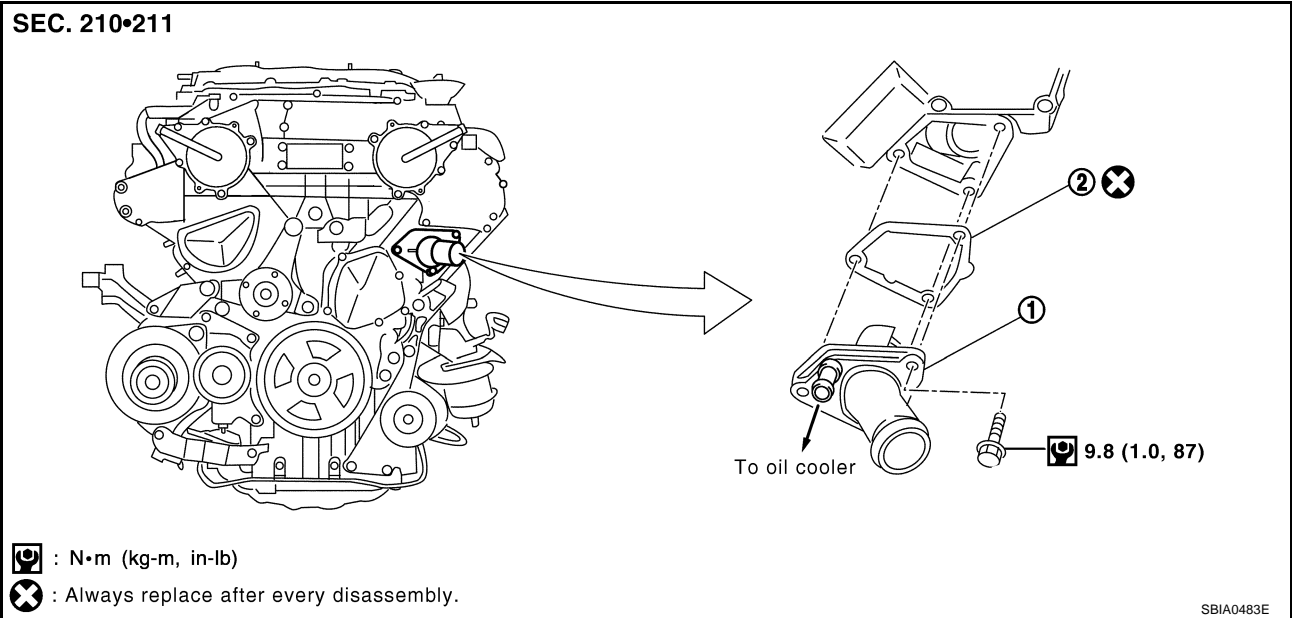

1. Water inlet and thermostat assembly 2. Gasket

Removal and Installation

NBS004R4

REMOVAL

1. Remove engine room cover (RH and LH). Refer to [EM-14, "ENGINE ROOM COVER"](#) .
2. Remove air duct (inlet). Refer to [EM-17, "AIR CLEANER AND AIR DUCT"](#) .
3. Remove front engine undercover using power tool.
4. Drain engine coolant from radiator drain plug at the bottom of radiator, and from water drain plug at the front of cylinder block. Refer to [CO-11, "Changing Engine Coolant"](#) and [CO-24, "WATER PUMP"](#) .

CAUTION:

- Perform this step when the engine is cold.
- Do not spill engine coolant on drive belts.

5. Disconnect radiator hose (lower) and oil cooler water hose from water inlet and thermostat assembly.
6. Remove water inlet and thermostat assembly.

CAUTION:

Do not disassemble water inlet and thermostat assembly. Replace them as a unit, if necessary.

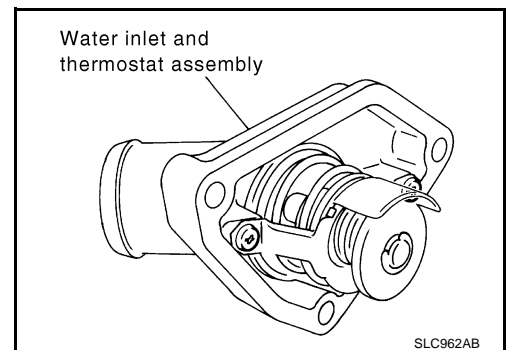

INSPECTION AFTER REMOVAL

1. Check valve seating condition at ordinary room temperatures. It should seat tightly.
2. Check valve operation.

Thermostat	Standard
Valve opening temperature	82°C (180°F)
Maximum valve lift	8.6 mm / 95°C (0.339 in / 203°F)
Valve closing temperature	77 °C (171°F)

- If the malfunctioning condition, when valve seating at ordinary room temperature, or measured values are out of the standard, replace water inlet and thermostat assembly.

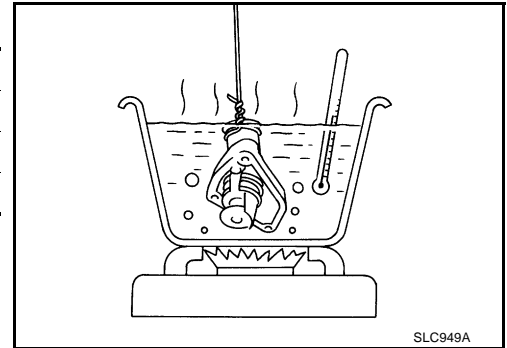

INSTALLATION

Note the following, and install in the reverse order of removal.

- **Be careful not to spill engine coolant over engine room. Use rag to absorb engine coolant.**

INSPECTION AFTER INSTALLATION

- Check for leaks of engine coolant using the radiator cap tester adapter [SST: EG17650301 (J33984-A)] and the radiator cap tester (commercial service tool). Refer to [CO-11, "LEAK CHECK"](#).
- Start and warm up the engine. Visually make sure that there is no leaks of engine coolant.

WATER OUTLET AND WATER PIPING

PFP:11060

Components

NBS004R5

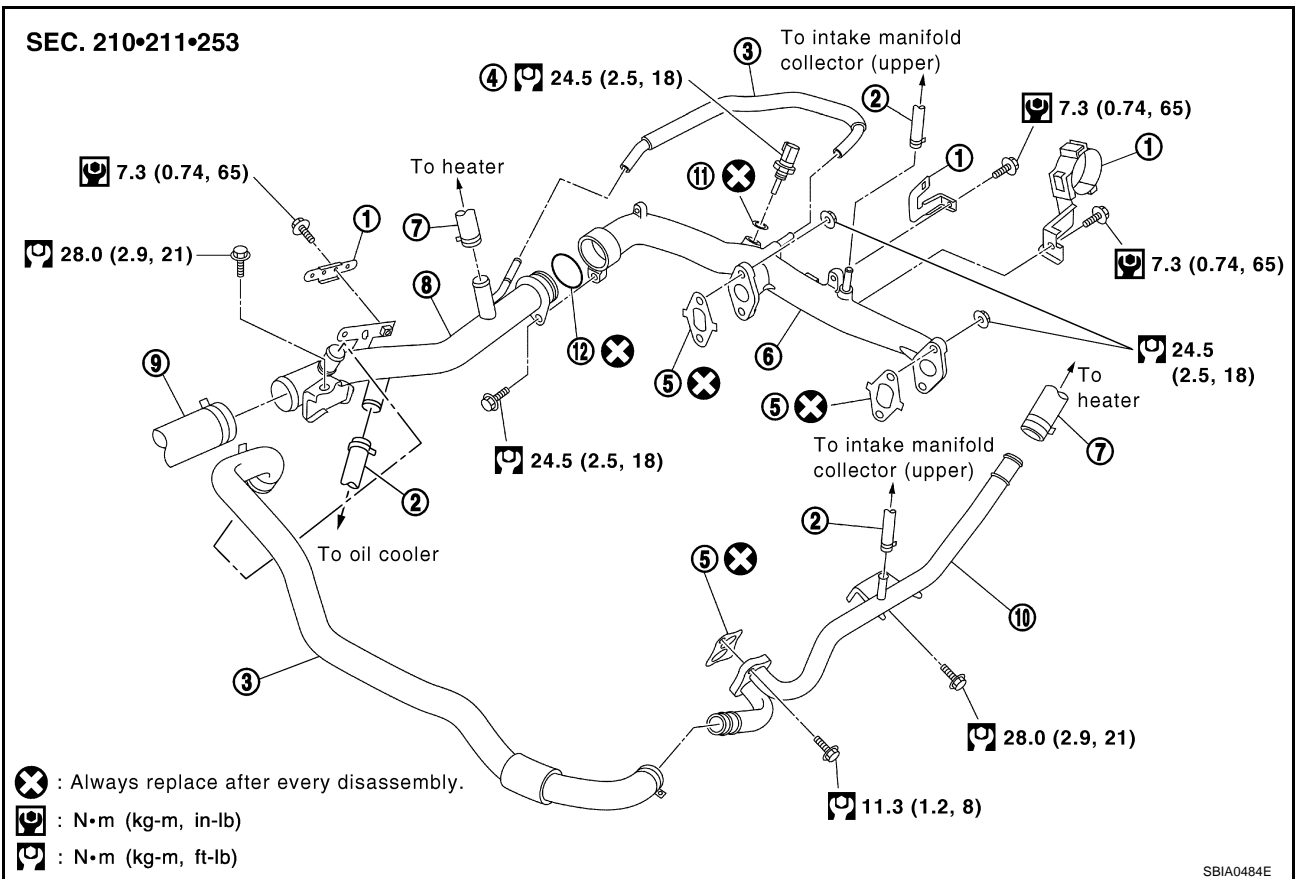

- | | | |
|--------------------------------------|---------------|--------------------------|
| 1. Harness bracket | 2. Water hose | 3. Water bypass hose |
| 4. Engine coolant temperature sensor | 5. Gasket | 6. Water outlet |
| 7. Heater hose | 8. Water pipe | 9. Radiator hose (upper) |
| 10. Heater pipe | 11. Washer | 12. O-ring |

Removal and Installation

REMOVAL

NBS004R6

- Remove engine room cover (RH and LH). Refer to [EM-14, "ENGINE ROOM COVER"](#) .
- Remove engine cover with power tool. Refer to [EM-19, "INTAKE MANIFOLD COLLECTOR"](#) .
- Remove air duct (inlet) and air cleaner case assembly. Refer to [EM-17, "AIR CLEANER AND AIR DUCT"](#) .
- Remove front engine undercover with power tool.
- Drain engine coolant from radiator drain plug at the bottom of radiator, and from water drain plug at the front of cylinder block. Refer to [CO-11, "Changing Engine Coolant"](#) and [CO-24, "WATER PUMP"](#) .

CAUTION:

- Perform this step when the engine is cold.
- Do not spill engine coolant on drive belts.

- Remove radiator hose (upper) and heater hose.
- Remove the following parts, when remove water outlet.
 - A/T fluid charging pipe: Refer to [AT-271, "TRANSMISSION ASSEMBLY"](#) .
 - Intake manifold collectors (upper and lower): Refer to [EM-19, "INTAKE MANIFOLD COLLECTOR"](#) .
 - Rocker cover (right bank): Refer to [EM-51, "ROCKER COVER"](#) .
- Remove engine coolant temperature sensor as necessary.

CAUTION:

Be careful not to damage engine coolant temperature sensor.

9. Remove heater pipe, water bypass hoses and water pipe.

INSTALLATION

Note the following, and install in the reverse order of removal.

- Securely insert each hose, and install clamp at a position where it does not interfere with the pipe bulge.
- When inserting water pipe into water outlet, apply neutral detergent to O-ring.

INSPECTION AFTER INSTALLATION

- Check for leaks of engine coolant using the radiator cap tester adapter [SST: EG17650301 (J33984-A)] and the radiator cap tester (commercial service tool). Refer to [CO-11, "LEAK CHECK"](#).
- Start and warm up the engine. Visually make sure that there is no leaks of engine coolant.

SERVICE DATA AND SPECIFICATIONS (SDS)

[VQ35DE]

SERVICE DATA AND SPECIFICATIONS (SDS)

PFP:00100

Standard and Limit

NBS004R7

ENGINE COOLANT CAPACITY (APPROXIMATE)

Unit: ℓ (US qt, Imp qt)

Engine coolant capacity [With reservoir tank ("MAX" level)]	8.9 (9-3/8, 7- 7/8)
Reservoir tank engine coolant capacity (At "MAX" level)	0.6 (5/8, 1/2)

RADIATOR

Unit: kPa (kg/cm² , psi)

Radiator cap relief pressure	Standard	78 - 98 (0.8 - 1.0, 11 - 14)
	Limit	59 (0.6, 9)
Leakage testing pressure		157 (1.6, 23)

THERMOSTAT

Thermostat	Standard
Valve opening temperature	82°C (180°F)
Maximum valve lift	8.6 mm / 95°C (0.339 in / 203°F)
Valve closing temperature	77°C (171°F)

A
CO
C
D
E
F
G
H
I
J
K
L
M

PRECAUTIONS

PFP:00001

Precautions for Supplemental Restraint System (SRS) “AIR BAG” and “SEAT BELT PRE-TENSIONER”

NBS004R8

The Supplemental Restraint System such as “AIR BAG” and “SEAT BELT PRE-TENSIONER”, used along with a front seat belt, helps to reduce the risk or severity of injury to the driver and front passenger for certain types of collision. This system includes seat belt switch inputs and dual stage front air bag modules. The SRS system uses the seat belt switches to determine the front air bag deployment, and may only deploy one front air bag, depending on the severity of a collision and whether the front occupants are belted or unbelted. Information necessary to service the system safely is included in the SRS and SB section of this Service Manual.

WARNING:

- To avoid rendering the SRS inoperative, which could increase the risk of personal injury or death in the event of a collision which would result in air bag inflation, all maintenance must be performed by an authorized NISSAN/INFINITI dealer.
- Improper maintenance, including incorrect removal and installation of the SRS, can lead to personal injury caused by unintentional activation of the system. For removal of Spiral Cable and Air Bag Module, see the SRS section.
- Do not use electrical test equipment on any circuit related to the SRS unless instructed to in this Service Manual. SRS wiring harnesses can be identified by yellow and/or orange harnesses or harness connectors.

PREPARATION

[VK45DE]



PREPARATION

PFP:00002

Special Service Tools

NBS004R9

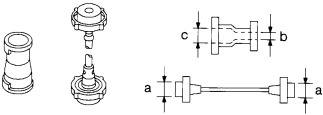
The actual shapes of Kent-Moore tools may from those of special service tools illustrated here.

Tool number (Kent-Moore No.) Tool name	Description
EG17650301 (J33984-A) Radiator cap tester adapter <div style="text-align: center;">  <p>S-NT564</p> </div>	Adapting radiator cap tester to radiator cap and thermostat housing filler neck a: 28 (1.10) dia. b: 31.4 (1.236) dia. c: 41.3 (1.626) dia. Unit: mm (in)
KV99103510 (—) Radiator plate pliers A <div style="text-align: center;">  <p>S-NT224</p> </div>	Installing radiator upper and lower tanks
KV99103520 (—) Radiator plate pliers B <div style="text-align: center;">  <p>S-NT225</p> </div>	Removing radiator upper and lower tanks

Commercial Service Tools

NBS004RA

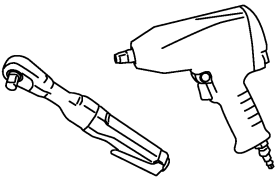
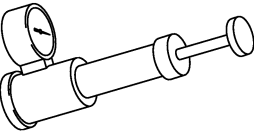
Tool name	Description
Power tool <div style="text-align: center;">  <p>PBIC0190E</p> </div>	Loosening nuts and bolts
Radiator cap tester <div style="text-align: center;">  <p>PBIC1982E</p> </div>	Checking radiator and radiator cap

OVERHEATING CAUSE ANALYSIS

[VK45DE]

OVERHEATING CAUSE ANALYSIS

PFP:00012

Troubleshooting Chart

NBS004RB

		Symptom	Check items	
Cooling system parts malfunction	Poor heat transfer	Water pump malfunction	Worn or loose drive belt	—
		Thermostat and water control valve stuck closed	—	
		Damaged fins	Dust contamination or paper clogging	
			Physical damage	
	Clogged radiator cooling tube	Excess foreign material (rust, dirt, sand, etc.)		
	Reduced air flow	Cooling fan does not operate	Fan assembly	—
		High resistance to fan rotation		
		Damaged fan blades		
	Damaged radiator shroud	—	—	—
	Improper engine coolant mixture ratio	—	—	—
	Poor engine coolant quality	—	Engine coolant density	—
	Insufficient engine coolant	Engine coolant leaks	Cooling hose	Loose clamp
				Cracked hose
			Water pump	Poor sealing
Radiator cap			Loose	
		Poor sealing		
Radiator		O-ring for damage, deterioration or improper fitting		
		Cracked radiator tank		
Reservoir tank	Cracked radiator core			
Overflowing reservoir tank	Exhaust gas leaks into cooling system	Cracked reservoir tank		
		Cylinder head deterioration		
			Cylinder head gasket deterioration	

OVERHEATING CAUSE ANALYSIS

[VK45DE]

	Symptom		Check items			
Except cooling system parts malfunction	—	Overload on engine	Abusive driving	High engine rpm under no load	A	
				Driving in low gear for extended time	CO	
				Driving at extremely high speed		
					Powertrain system malfunction	C
					Installed improper size wheels and tires	D
					Dragging brakes	
			Improper ignition timing	E		
	Blocked or restricted air flow		Blocked bumper	—		
			Blocked radiator grille	Installed car brassiere		F
				Mud contamination or paper clogging	—	
		Blocked radiator	—			
		Blocked condenser	Blocked air flow		G	
	Installed large fog lamp					

A
CO
C
D
E
F
G
H
I
J
K
L
M

COOLING SYSTEM

[VK45DE]

COOLING SYSTEM

PFP:21020

Cooling Circuit

NBS004RC

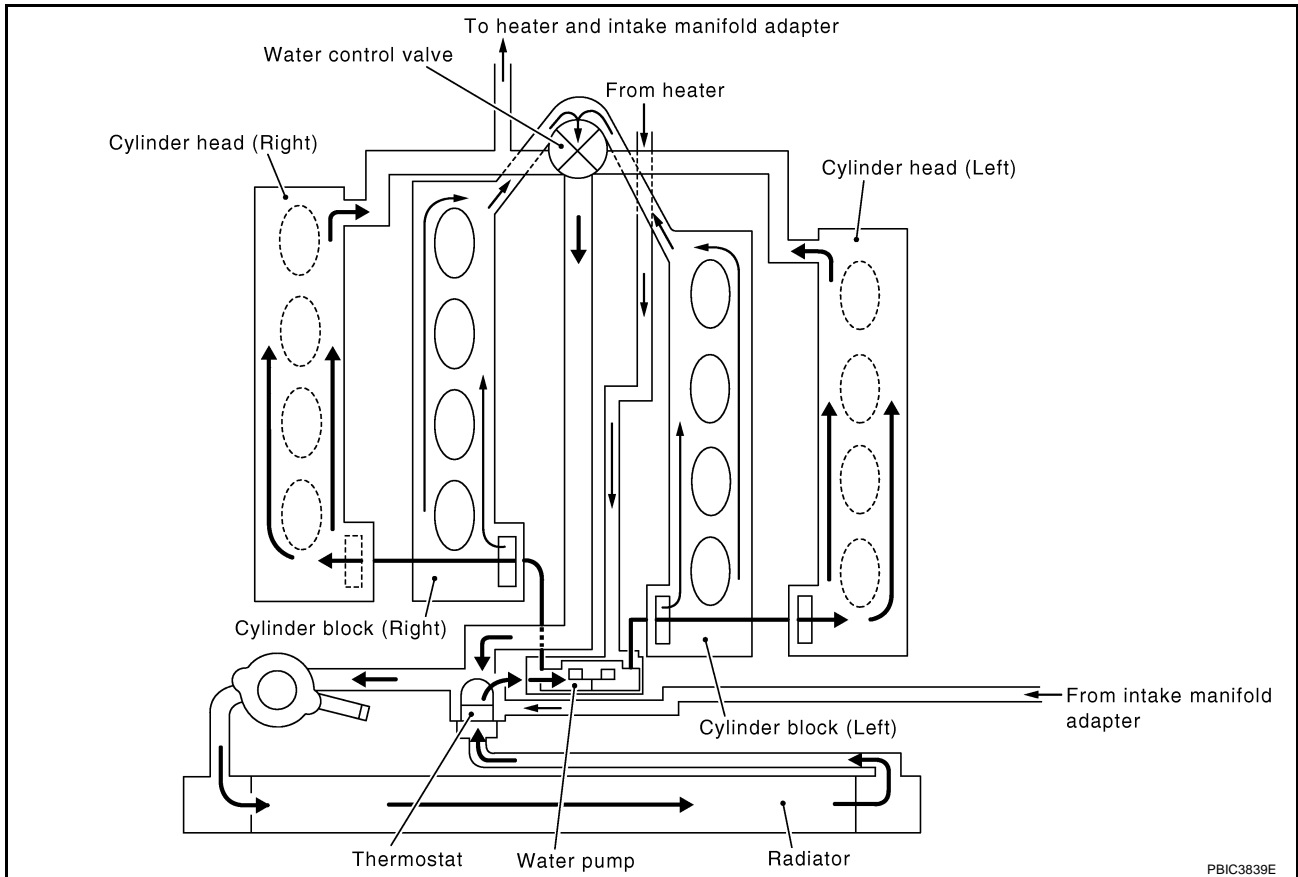

COOLING SYSTEM

[VK45DE]

System Chart

NBS004RD

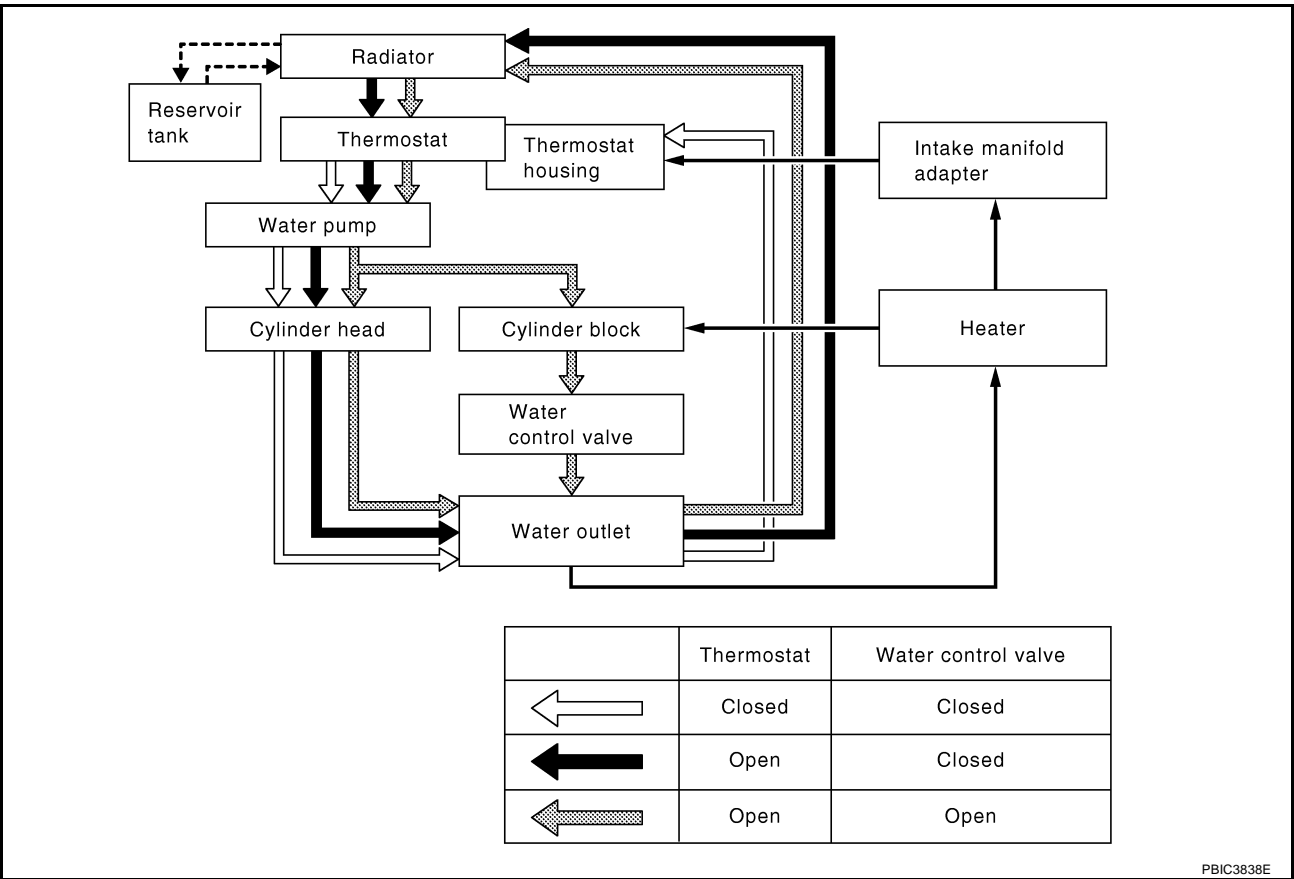

PBIC3838E

A
CO
C
D
E
F
G
H
I
J
K
L
M

ENGINE COOLANT

PFPP:KQ100

Inspection LEVEL CHECK

NBS004RE

- Check if the reservoir tank engine coolant level is within the "MIN" to "MAX" when engine is cool.
- Adjust the engine coolant level as necessary.

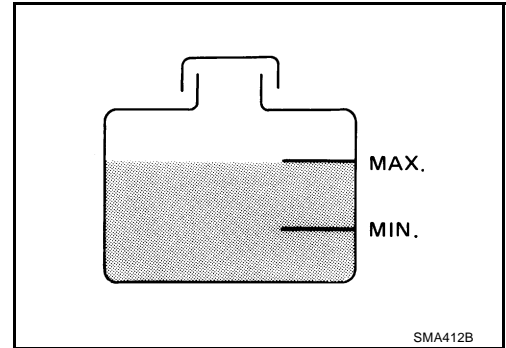

LEAK CHECK

- To check for leaks, apply pressure to the cooling system with radiator cap tester (commercial service tool) and radiator cap tester adapter (SST).

Testing pressure : 157 kPa (1.6 kg/cm² , 23 psi)

WARNING:

Do not remove radiator cap when engine is hot. Serious burns could occur from high-pressure engine coolant escaping from thermostat housing.

CAUTION:

Higher testing pressure than specified may cause radiator damage.

NOTE:

In a case engine coolant decreases, replenish radiator with engine coolant.

- If anything is found, repair or replace damaged parts.

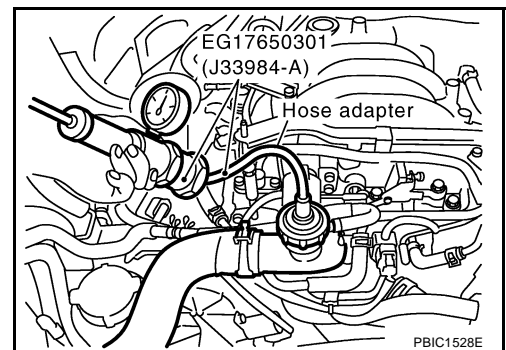

Changing Engine Coolant

NBS004RF

WARNING:

- To avoid being scalded, do not change engine coolant when engine is hot.
- Wrap a thick cloth around radiator cap and carefully remove radiator cap. First, turn radiator cap a quarter of a turn to release built-up pressure. Then turn radiator cap all the way.

DRAINING ENGINE COOLANT

1. Remove engine room cover (RH and LH). Refer to [EM-173, "ENGINE ROOM COVER"](#) .
2. Remove engine cover with power tool. Refer to [EM-179, "INTAKE MANIFOLD"](#) .
3. Open radiator drain plug at the bottom of radiator, and then remove radiator cap.

- 1 : Radiator drain plug hole
- 2 : Front engine undercover
- ↶ : Engine front

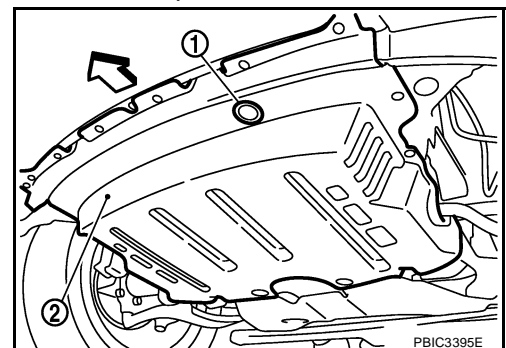

When draining all of engine coolant in the system, open water drain plugs on cylinder block. Refer to [EM-250, "DISASSEMBLY"](#) .

4. Remove reservoir tank as necessary, and drain engine coolant and clean reservoir tank before installing.

- Check drained engine coolant for contaminants such as rust, corrosion or discoloration. If contaminated, flush the engine cooling system. Refer to [CO-42. "FLUSHING COOLING SYSTEM"](#).

REFILLING ENGINE COOLANT

- Install reservoir tank if removed, and radiator drain plug.

CAUTION:

Be sure to clean radiator drain plug and install with new O-ring.

Radiator drain plug:

 : 1.2 N·m (0.12 kg·m, 11 in·lb)

If water drain plugs on cylinder block are removed, close and tighten them. Refer to [EM-254. "ASSEMBLY"](#).

- Make sure that each hose clamp has been firmly tightened.
- Remove air relief plug (1) on heater hose.

 : Engine front

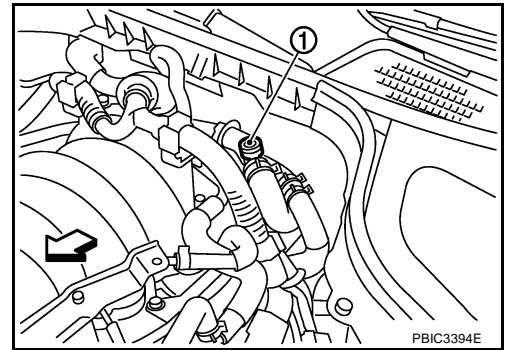

- Fill thermostat housing and reservoir tank to specified level.
 - Refill engine coolant up to filler neck of thermostat housing.
 - Pour engine coolant through engine coolant filler neck slowly of less than 2 ℓ (2-1/8 US qt, 1-3/4 Imp qt) a minute to allow air in system to escape.
 - Use Genuine Nissan Long Life Antifreeze/Coolant or equivalent mixed with water (distilled or demineralized). Refer to [MA-12. "RECOMMENDED FLUIDS AND LUBRICANTS"](#).

Engine coolant capacity

(With reservoir tank at "MAX" level):

Approx. 10.4 ℓ (11 US qt, 9-1/8 Imp qt)

Reservoir tank engine coolant capacity

(At "MAX" level):

0.6 ℓ (5/8 US qt, 1/2 Imp qt)

- When engine coolant overflows air relief hole on heater hose, install air relief plug.

Air relief plug:

 : 1.2 N·m (0.12 kg·m, 11 in·lb)

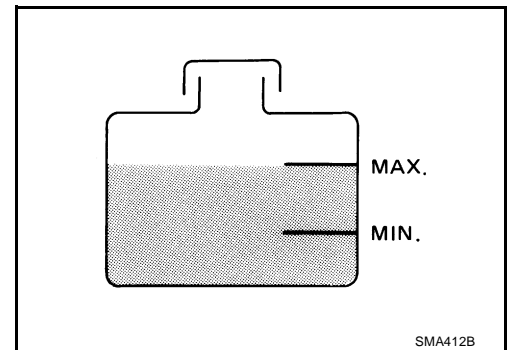

- Install radiator cap.
- Warm up until opening thermostat. Standard for warming-up time is approximately 10 minutes at 3,000 rpm.
 - Make sure thermostat opening condition by touching radiator hose (lower) to see a flow of warm water.

CAUTION:
Watch water temperature gauge so as not to overheat engine.
- Stop engine and cool down to less than approximately 50°C (122°F).
 - Cool down using a fan to reduce the time.

- If necessary, refill engine coolant up to filler neck of thermostat housing.
- 8. Refill reservoir tank to "MAX" level line with engine coolant.
- 9. Repeat steps 4 through 7 two or more times with radiator cap installed until engine coolant level no longer drops.
- 10. Check cooling system for leaks with engine running.
- 11. Warm up engine, and check for sound of engine coolant flow while running engine from idle up to 3,000 rpm with heater temperature controller set at several position between "COOL" and "WARM".
 - Sound may be noticeable at heater unit.
- 12. Repeat step 11 three times.
- 13. If sound is heard, bleed air from cooling system by repeating steps 4 through 7 until engine coolant level no longer drops.

FLUSHING COOLING SYSTEM

1. Install reservoir tank, and radiator drain plug.

CAUTION:

Be sure to clean drain plug and install with new O-ring.

Radiator drain plug:

 : 1.2 N·m (0.12 kg·m, 11 in·lb)

If water drain plugs on cylinder block are removed, close and tighten them. Refer to [EM-254, "ASSEMBLY"](#).

2. Remove air relief plug (1) on heater hose.

 : Engine front

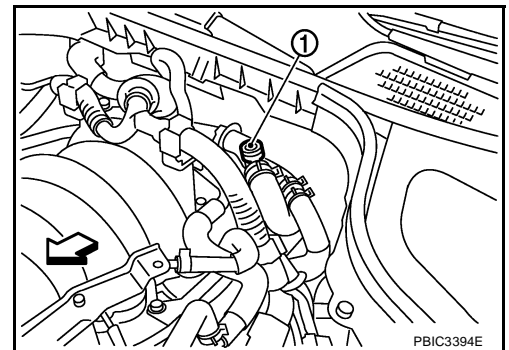

3. Fill thermostat housing with water until water spills from the air relief hole, then close air relief plug. Fill thermostat housing and reservoir tank with water and reinstall radiator cap.

Air relief plug:

 : 1.2 N·m (0.12 kg·m, 11 in·lb)

4. Run engine and warm it up to normal operating temperature.
5. Rev engine two or three times under no-load.
6. Stop engine and wait until it cools down.
7. Drain water from the system. Refer to [CO-40, "DRAINING ENGINE COOLANT"](#).
8. Repeat steps 1 through 7 until clear water begins to drain from radiator.

RADIATOR Components

PF2:21400

NBS004RG

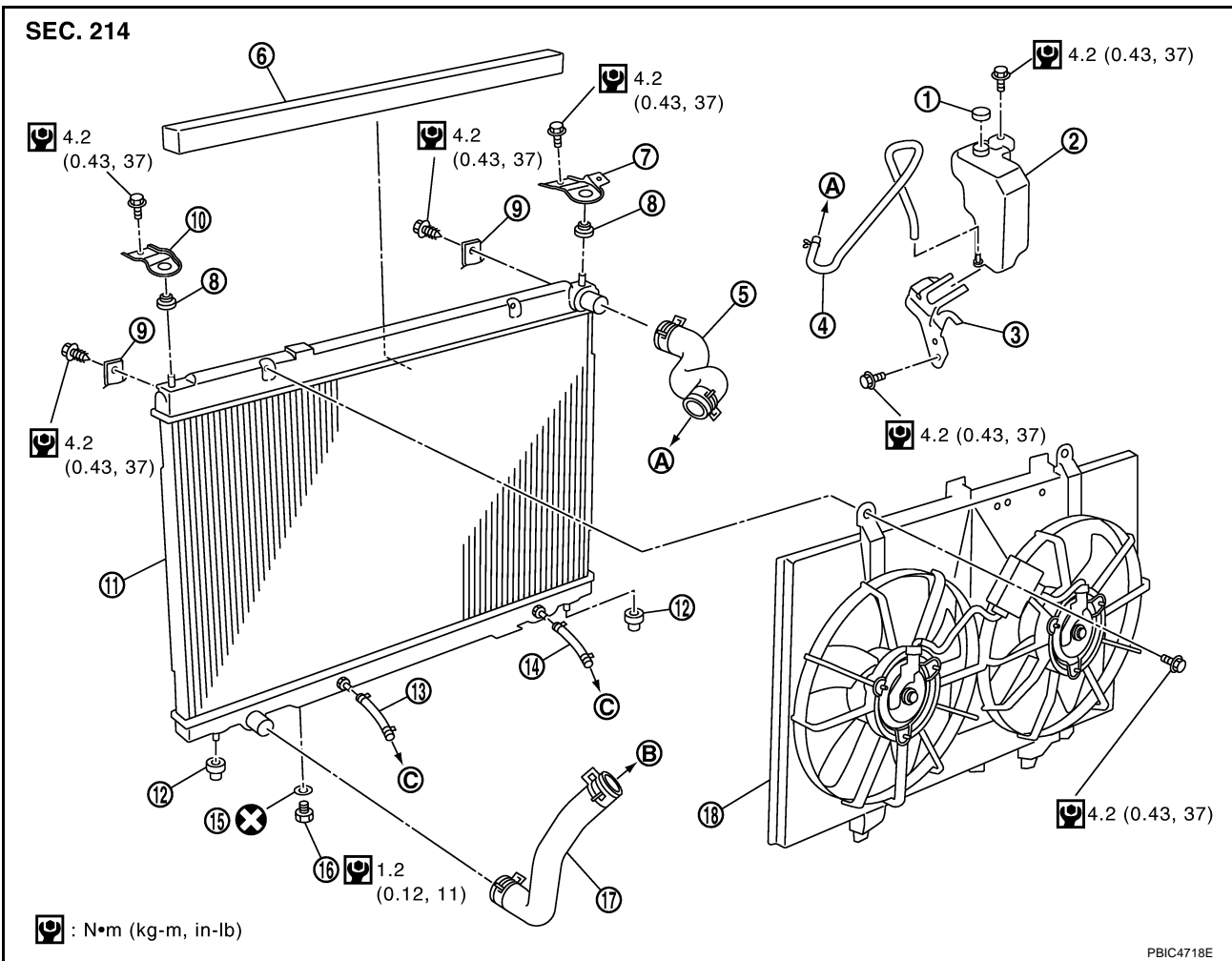

- | | | |
|---------------------------|----------------------------|-----------------------------|
| 1. Reservoir tank cap | 2. Reservoir tank | 3. Reservoir tank bracket |
| 4. Reservoir tank hose | 5. Radiator hose (upper) | 6. Air guide |
| 7. Mount bracket (RH) | 8. Mounting rubber (upper) | 9. A/C condenser |
| 10. Mount bracket (LH) | 11. Radiator | 12. Mounting rubber (lower) |
| 13. A/T fluid cooler hose | 14. A/T fluid cooler hose | 15. O-ring |
| 16. Drain plug | 17. Radiator hose (lower) | 18. Cooling fan assembly |
| A. To thermostat housing | B. To water suction pipe | C. To transmission |

- Refer to [GI-11, "Components"](#) for symbol marks in the figure.

Removal and Installation

NBS004RH

WARNING:

Do not remove radiator cap when engine is hot. Serious burns could occur from high-pressure engine coolant escaping from thermostat housing. Wrap a thick cloth around radiator cap. Slowly turn it a quarter of a turn to release built-up pressure. Carefully remove radiator cap by turning it all the way.

REMOVAL

- Remove the following parts:
 - Front engine undercover (power tool).
 - Engine room cover (RH and LH). Refer to [EM-173, "ENGINE ROOM COVER"](#).
 - Air duct (inlet) and air cleaner case assembly. Refer to [EM-177, "AIR CLEANER AND AIR DUCT"](#).
- Remove front grille and front grille support. Refer to [EI-16, "FRONT GRILLE"](#).
- Drain engine coolant from radiator. Refer to [CO-40, "ENGINE COOLANT"](#).

CAUTION:

- Perform this step when the engine is cold.
- Do not spill engine coolant on drive belts.

4. Remove the A/C piping bracket from left side member, and then move the A/C piping out of the way.
5. Disconnect A/T fluid cooler hoses from radiator.
 - Install blind plug to avoid leakage of A/T fluid.
6. Remove radiator hoses (upper and lower) and reservoir tank hose.

CAUTION:

Be careful not to allow engine coolant to contact drive belts.

7. Remove cooling fan assembly (1). Refer to [CO-51, "COOLING FAN"](#).

CAUTION:

Do not damage or scratch radiator core when removing.

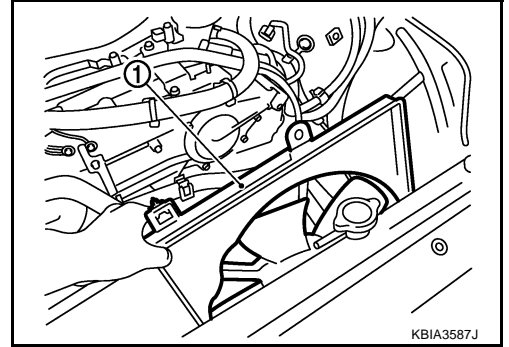

8. Remove radiator as follows:
 - a. Remove mount bracket (RH and LH).
 - b. Pull the radiator (1) rearward from the vehicle, and then remove the mounting bolts (3) and A/C condenser (2).

NOTE:

Figure shows right side.

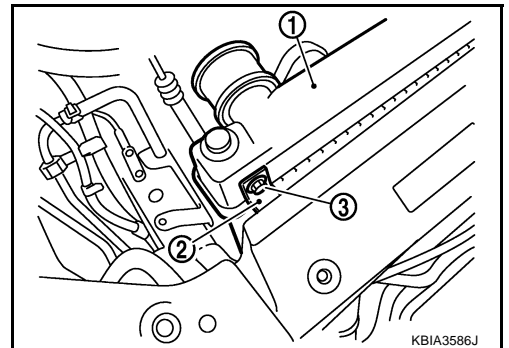

- c. Lift up and pull the radiator (4) rearward, and then remove the mounting rubber (lower) (3) from the radiator core support (2).

1 : A/C condenser

⇐ : Engine front

CAUTION:

At this time, A/C condenser is on the lower end of radiator front surface. Minimize the movement to the rear side.

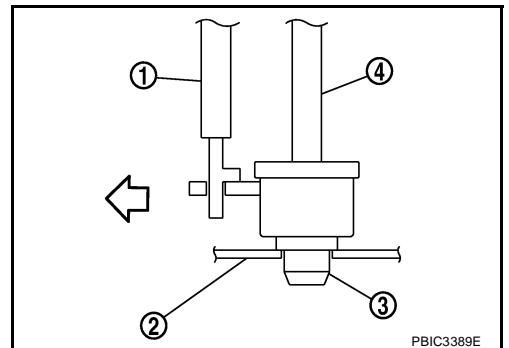

- d. Lift up the A/C condenser to disengage the lower end of front surface, and then remove the radiator.

CAUTION:

- Be careful not to damage radiator and A/C condenser core.
- Minimize the lift of A/C condenser to prevent load from being applied to A/C piping.

- e. After removing the radiator, place the A/C condenser on the radiator core support to prevent load from being applied to piping. And then, temporarily secure them using a rope to prevent them from being dropped.

INSTALLATION

Installation is the reverse order of removal.

INSPECTION AFTER INSTALLATION

- Check for leaks of engine coolant using radiator cap tester adapter [SST: EG17650301 (J33984-A)] and radiator cap tester (commercial service tool). Refer to [CO-40, "LEAK CHECK"](#).
- Start and warm up engine. Visually Check if there is no leaks of engine coolant and A/T fluid.

Checking Radiator Cap

- Check valve seat of radiator cap.
 - Check if valve seat is swollen to the extent that the edge of the plunger cannot be seen when watching it vertically from the top.
 - Check if valve seat has no soil and damage.

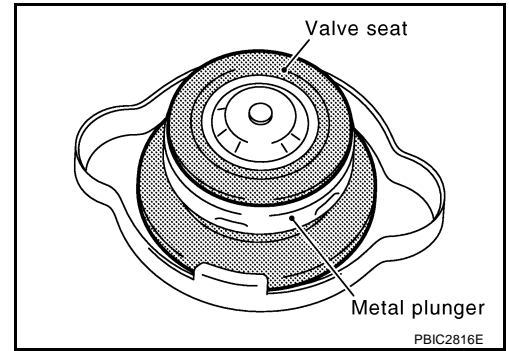

- Pull negative-pressure valve to open it, and make sure that it close completely when released.
 - Make sure that there is no dirt or damage on the valve seat of radiator cap negative-pressure valve.
 - Make sure that there are no unusualness in the opening and closing conditions of negative-pressure valve.

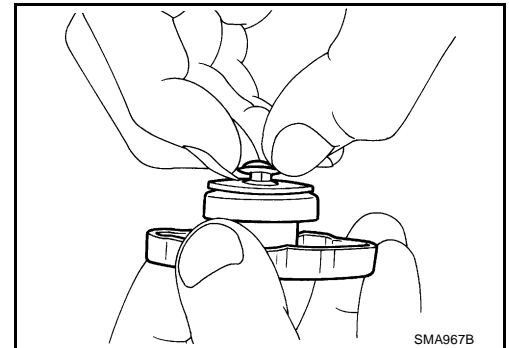

- Check radiator cap relief pressure.

Standard : 78 - 98 kPa (0.8 - 1.0 kg/cm² , 11 - 14 psi)

Limit : 59 kPa (0.6 kg/cm² , 9 psi)

- When connecting radiator cap to the radiator cap tester adapter (SST) and the radiator cap tester (Commercial service tool), apply engine coolant to the cap seal surface.

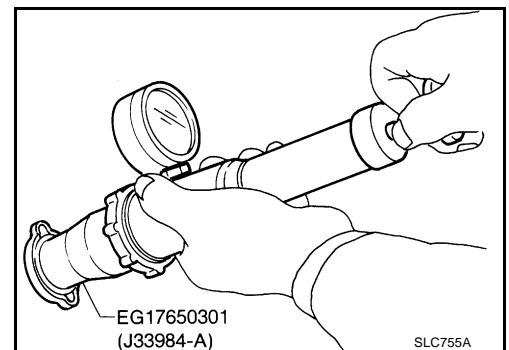

- Replace radiator cap if there is an unusualness.

CAUTION:

When installing a radiator cap, thoroughly wipe out the radiator filler neck to remove any waxy residue or foreign material.

Checking Radiator

Check radiator for mud or clogging. If necessary, clean radiator as follows:

- Be careful not to bend or damage the radiator fins.
 - When radiator is cleaned without removal, remove all surrounding parts such as cooling fan, radiator shroud and horns. Then tape the harness and electrical connectors to prevent water from entering.
1. Apply water by hose to the back side of the radiator core vertically downward.
 2. Apply water again to all radiator core surface once per minute.

RADIATOR

[VK45DE]

3. Stop washing if any stains no longer flow out from radiator.
4. Blow air into the back side of radiator core vertically downward.
 - Use compressed air lower than 490 kPa (5 kg/cm² , 71 psi) and keep distance more than 30 cm (11.8 in).
5. Blow air again into all the radiator core surfaces once per minute until no water sprays out.

RADIATOR (ALUMINUM TYPE)

PFP:21460

Components

NBS004RK

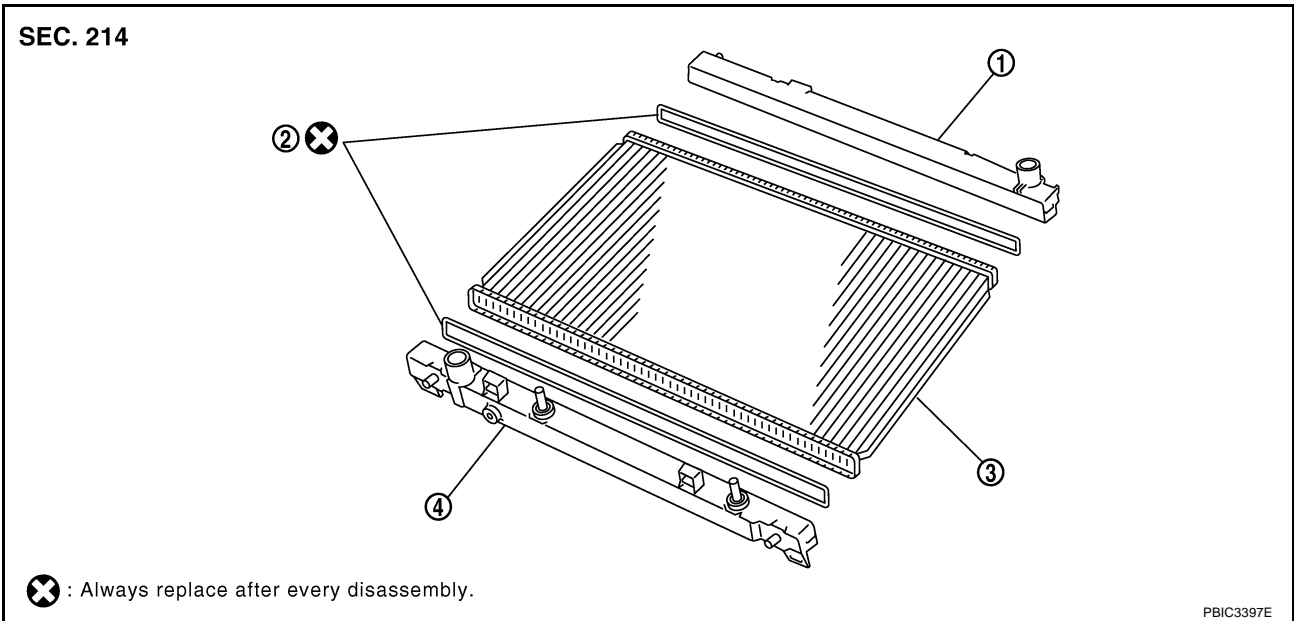

1. Upper tank
2. Sealing rubber
3. Core
4. Lower tank (with A/T fluid cooler)

Disassembly and Assembly PREPARATION

NBS004RL

1. Attach spacer to tip of radiator plate pliers A (SST).
Spacer specification: 18 mm (0.71 in) wide × 8.5 mm (0.335 in) long × 1.5 mm (0.059 in) thick.

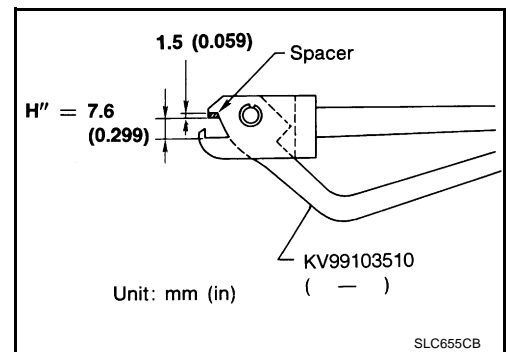

2. Make sure that when radiator plate pliers A are closed dimension H'' is approx. 7.6 mm (0.299 in).
3. Adjust dimension H'' with spacer, if necessary.

DISASSEMBLY

1. Remove upper and lower tanks with radiator plate pliers B (SST).

CAUTION:

Do not disassemble lower tank and A/T fluid cooler.

NOTE:

Regard lower tank and A/T fluid cooler as an assembly.

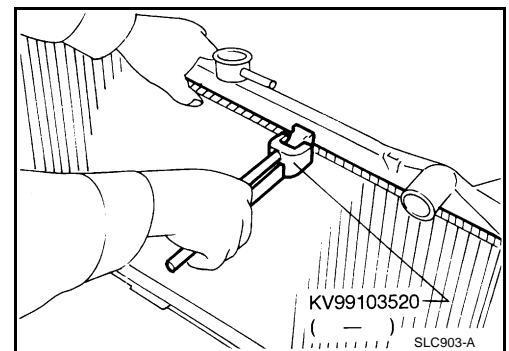

RADIATOR (ALUMINUM TYPE)

[VK45DE]

- Grip the crimped edge and bend it upwards so that radiator plate pliers B slips off.

CAUTION:

Do not bend excessively.

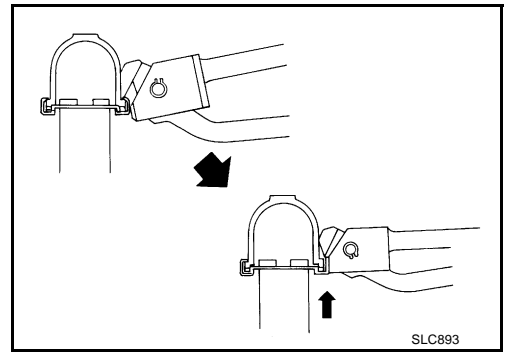

- In areas where radiator plate pliers B cannot be used, use flat-blade screwdriver to bend the edge up.

CAUTION:

Be careful not to damage tank.

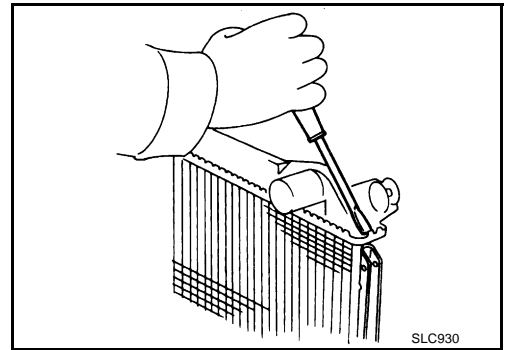

2. Remove sealing rubber.
3. Make sure the edge stands straight up.

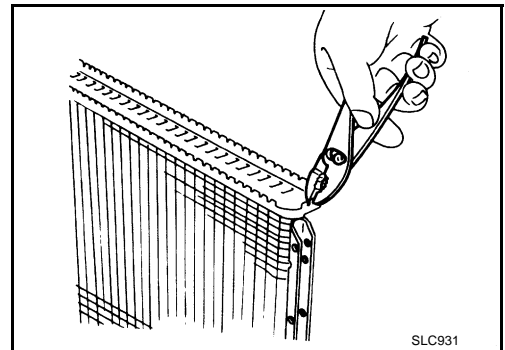

ASSEMBLY

1. Clean contact portion of tank.

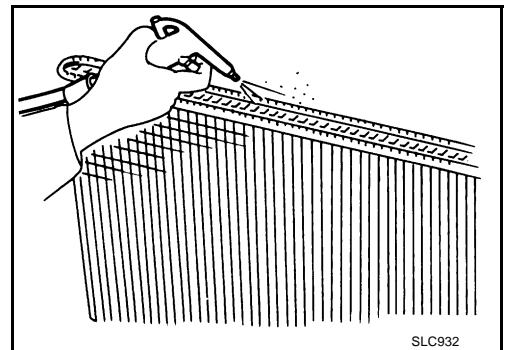

RADIATOR (ALUMINUM TYPE)

[VK45DE]

2. Install new sealing rubber while pushing it with fingers.

CAUTION:
Be careful not to twist sealing rubber.

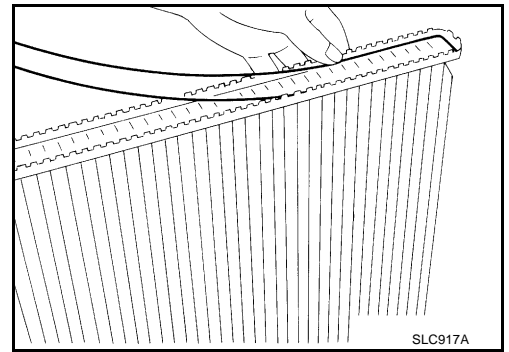

3. Caulk tank in numerical order as shown in the figure with radiator plate pliers A (SST).

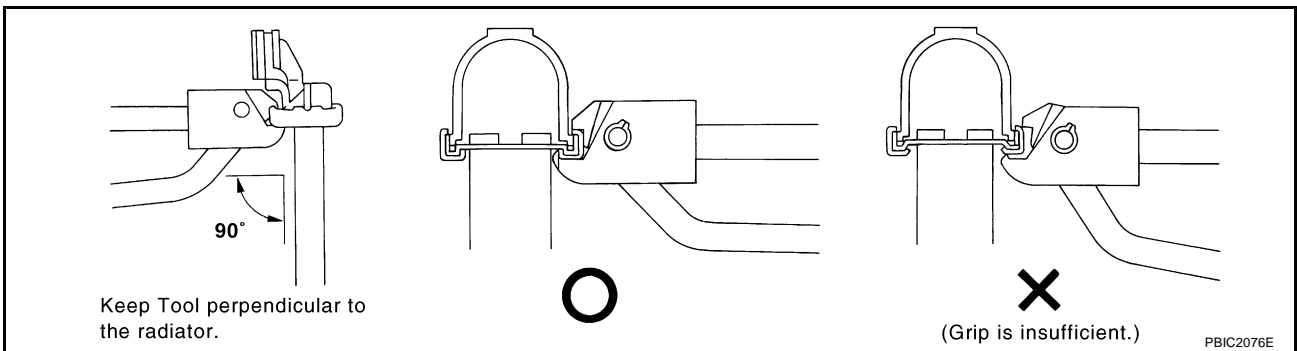
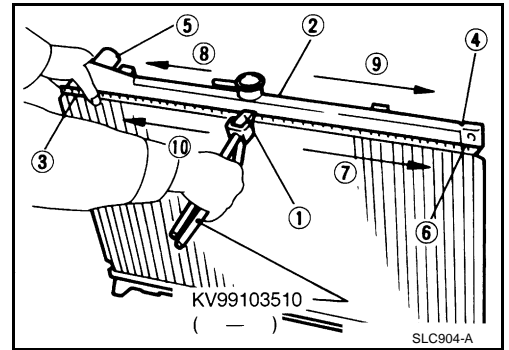

- Use pliers in the locations where radiator plate pliers A cannot be used.

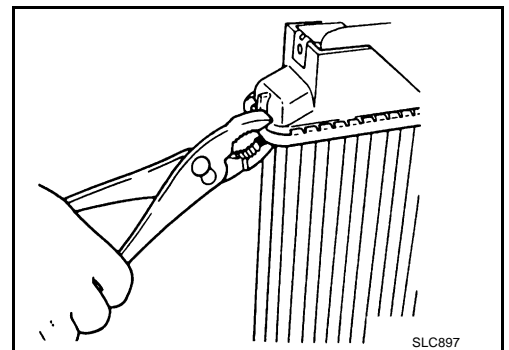

A
CO
C
D
E
F
G
H
I
J
K
L
M

RADIATOR (ALUMINUM TYPE)

[VK45DE]

4. Make sure that the rim is completely crimped down.

Standard height "H" : 8.0 - 8.4 mm (0.315 - 0.331 in)

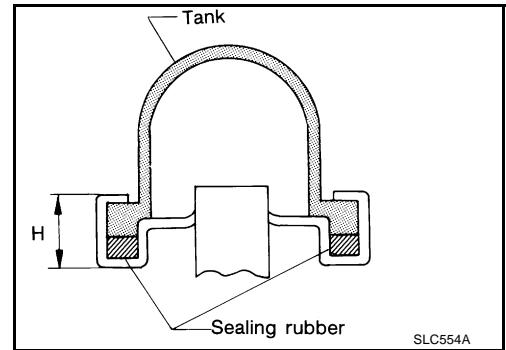

5. Make sure that there is no leakage. Refer to [CO-50, "INSPECTION"](#) .

INSPECTION

1. Apply pressure with radiator cap tester adapter (SST) and radiator cap tester (commercial service tool).
- provide used radiator and connect it to tested radiator using radiator hoses as shown in the figure.

NOTE:

The used radiator should be tested beforehand to confirm it has no leakage. If used one is not available, it is possible to use new service part as a radiator testing tool.

Testing pressure

: 157 kPa (1.6 kg/cm² , 23 psi)

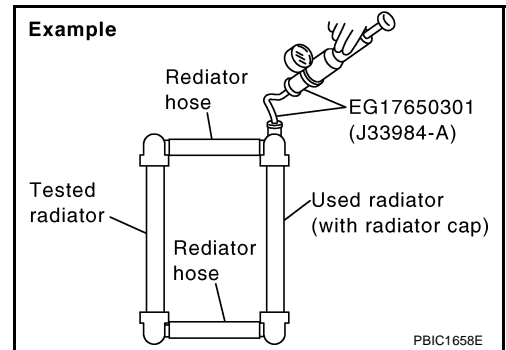

WARNING:

To prevent the risk of hose coming undone while under pressure, securely fasten it down with hose clamp.

CAUTION:

Attach hose to A/T fluid cooler to seal its inlet and outlet.

2. Check for leakage by soaking radiator in water container with the testing pressure applied.

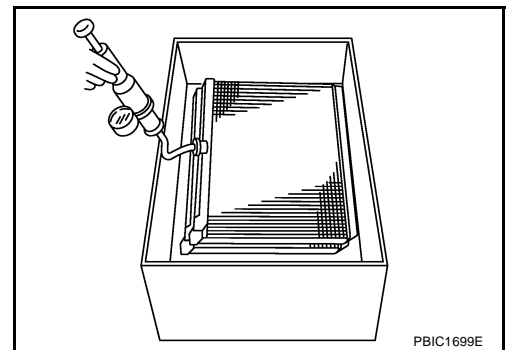

COOLING FAN

PF21140

Components

NBS004RM

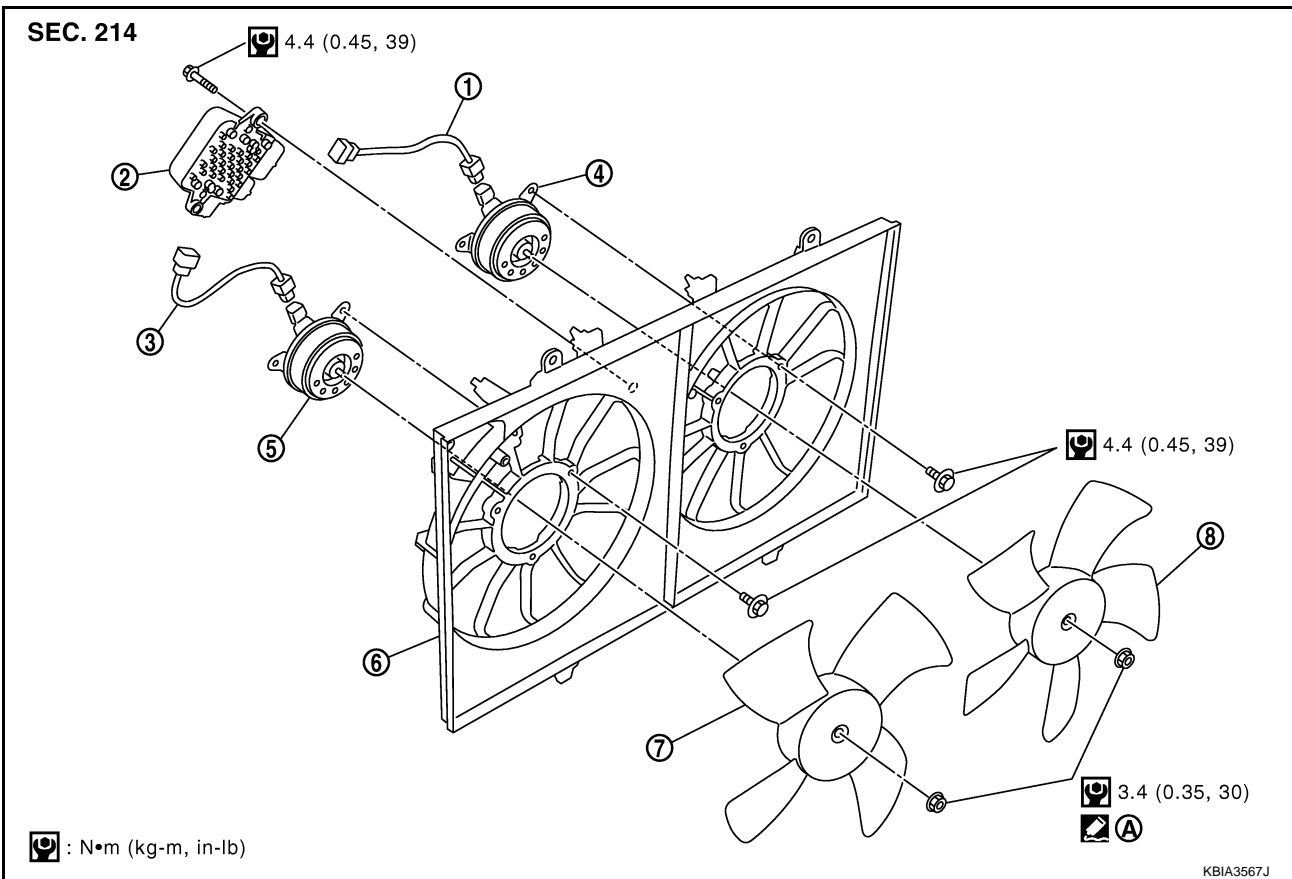

- | | | |
|---------------------|-------------------------------|----------------|
| 1. Sub-harness | 2. Cooling fan control module | 3. Sub-harness |
| 4. Fan motor (LH) | 5. Fan motor (RH) | 6. Fan shroud |
| 7. Cooling fan (RH) | 8. Cooling fan (LH) | |

A. Apply on fan motor shaft.

Apply Genuine High Strength Locking Sealant or equivalent.

Removal and Installation

REMOVAL

1. Remove engine room cover (RH and LH). Refer to [EM-173, "ENGINE ROOM COVER"](#).
2. Remove air duct (inlet) and air cleaner case assembly. Refer to [EM-177, "AIR CLEANER AND AIR DUCT"](#).
3. Drain engine coolant from radiator. Refer to [CO-40, "ENGINE COOLANT"](#).
4. Disconnect harness connector from cooling fan control module, and move harness to aside.
5. Remove radiator hose (upper). Refer to [CO-43, "RADIATOR"](#).
6. Remove cooling fan assembly.

CAUTION:

Be careful not to damage or scratch on radiator core.

INSTALLATION

Note the following, and Install in the reverse order of removal.

CAUTION:

Only use genuine parts for radiator shroud and cooling fan mounting bolt and observe the specified torque (to prevent radiator from being damaged).

INSPECTION AFTER INSTALLATION

Make sure that fan motors operate normally.

NOTE:

Cooling fans are controlled by cooling fan control module. For details. Refer to [EC-1239, "DTC P1217 ENGINE OVER TEMPERATURE"](#).

Disassembly and Assembly

NBS004R0

DISASSEMBLY

1. Disconnect sub-harness from fan motor (RH and LH) and cooling fan control module.
2. Remove cooling fan control module from fan shroud.

CAUTION:

Handle carefully to avoid dropping and shocks.

3. Remove cooling fan mounting nuts, and then remove the cooling fan (RH and LH).
4. Remove fan motor (RH and LH).

INSPECTION AFTER DISASSEMBLY**Cooling Fan**

Inspect cooling fan for crack or unusual bend.

- If anything is found, replace cooling fan.

ASSEMBLY

Note the following, and assemble in the reverse order of disassembly.

CAUTION:

RH and LH cooling fans are different. Be careful not to misassemble them.

- Install each fan in the following position.

Right side : 4 fans

Left side : 5 fans

- Secure the sub-harness tightly to the fan shroud to prevent the fan rotation area from being loose.

WATER PUMP

PFP:21020

Components

NBS004RP

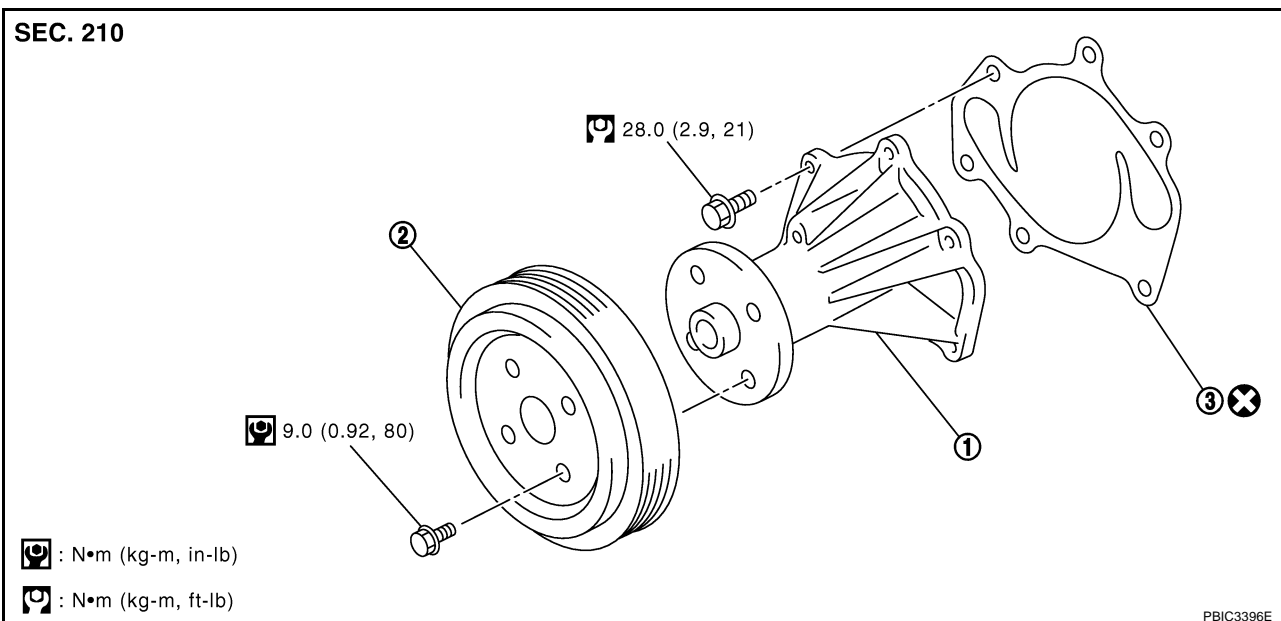

1. Water pump
2. Water pump pulley
3. Gasket

- Refer to [GI-11, "Components"](#) for symbol marks in the figure.

Removal and Installation

NBS004RQ

CAUTION:

- When removing water pump, be careful not to get engine coolant on drive belts.
- Water pump can not be disassembled and should be replaced as a unit.
- After installing water pump, connect hose and clamp securely, then check for leaks using radiator cap tester (commercial service tool) and radiator cap tester adapter [SST: EG17650301 (J33984-A)].

REMOVAL

1. Remove following parts:
 - Front engine undercover (power tool)
 - Engine cover: Refer to [EM-179, "INTAKE MANIFOLD"](#) .
 - Engine room cover (RH and LH): Refer to [EM-173, "ENGINE ROOM COVER"](#) .
 - Air duct (inlet): Refer to [EM-177, "AIR CLEANER AND AIR DUCT"](#) .
 - Alternator, water pump and A/C compressor belt: Refer to [EM-174, "DRIVE BELTS"](#) .
2. Drain engine coolant from drain plugs on radiator and both side of cylinder block. Refer to [CO-40, "Changing Engine Coolant"](#) and [EM-250, "DISASSEMBLY"](#) .

CAUTION:

- Perform this step when engine is cold.
 - Do not spill engine coolant on drive belts.
3. Remove water pump pulley.
 4. Remove water pump.
 - Engine coolant will leak from cylinder block, so have a receptacle ready under vehicle.

CAUTION:

- Handle the water pump vane so that it does not contact any other parts.
- Do not disassemble water pump.

INSPECTION AFTER REMOVAL

- Visually check that there is no significant dirt or rusting on water pump body and vane.
- Make sure there is no looseness in vane shaft, and that it turns smoothly when rotated by hand.
- If anything is found, replace water pump.

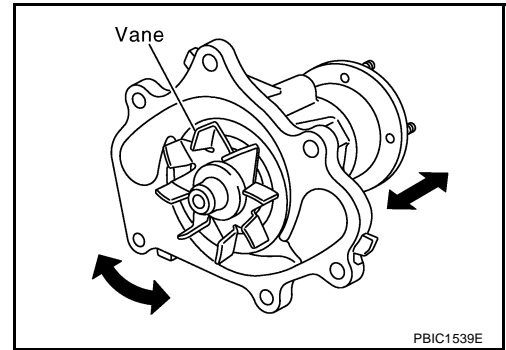

INSTALLATION

Installation is the reverse order of removal.

INSPECTION AFTER INSTALLATION

- Check for leaks of engine coolant using radiator cap tester adapter [SST: EG17650301 (J-33984-A)] and radiator cap tester (commercial service tool). Refer to [CO-40, "LEAK CHECK"](#).
- Start and warm up engine. Visually check if there is no leaks of engine coolant.

THERMOSTAT AND WATER CONTROL VALVE

PFP:21200

Components

NBS004RR

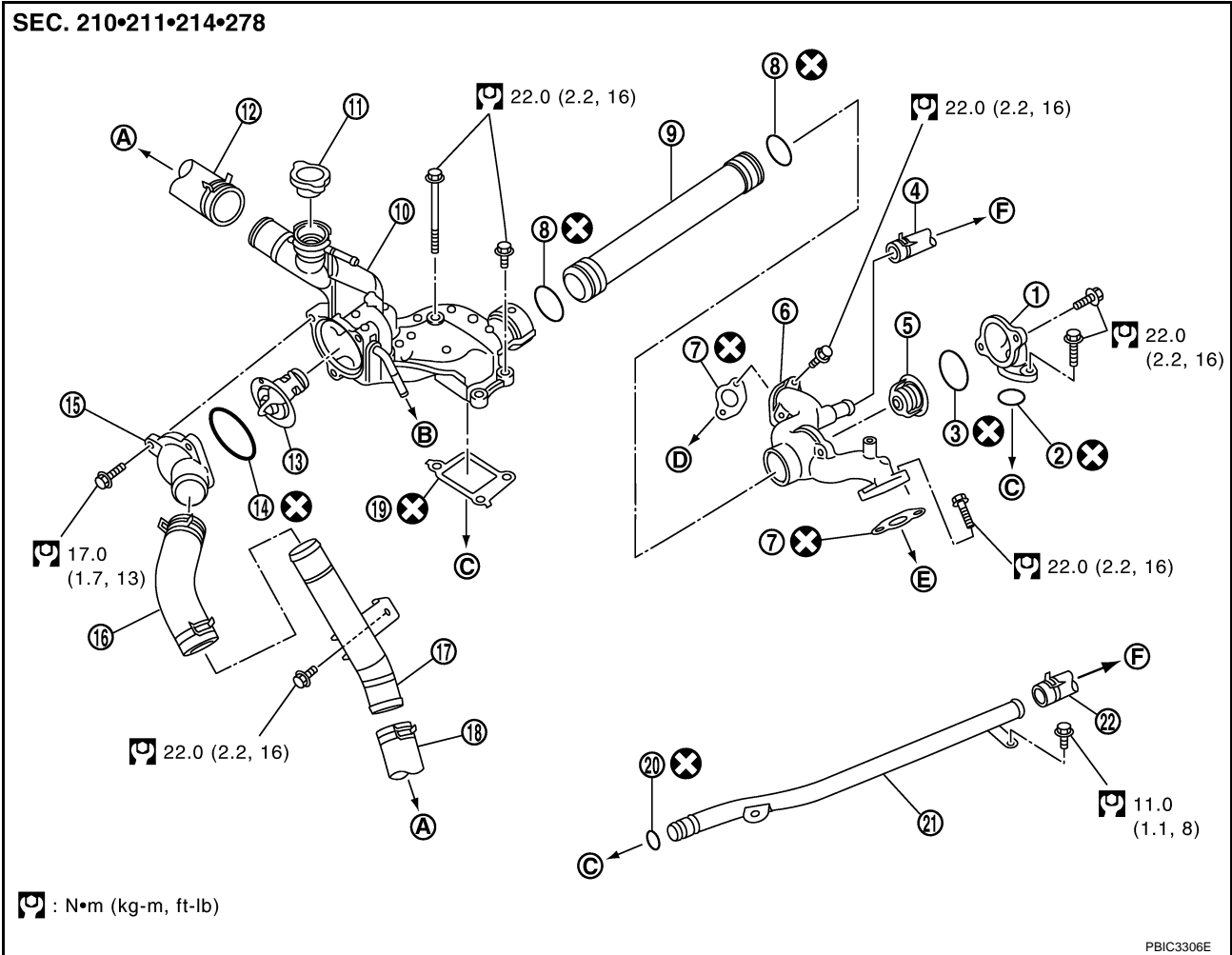

- | | | |
|------------------------|------------------------|---------------------------|
| 1. Water connector | 2. O-ring | 3. Rubber ring |
| 4. Heater hose | 5. Water control valve | 6. Water outlet |
| 7. Gasket | 8. O-ring | 9. Water outlet pipe |
| 10. Thermostat housing | 11. Radiator cap | 12. Radiator hose (upper) |
| 13. Thermostat | 14. Rubber ring | 15. Water inlet |
| 16. Water suction hose | 17. Water suction pipe | 18. Radiator hose (lower) |
| 19. Gasket | 20. O-ring | 21. Heater pipe |
| 22. Heater hose | | |
- A. To radiator
 B. To intake manifold adapter
 C. To cylinder block
 D. To cylinder head (right bank)
 E. To cylinder head (left bank)
 F. To heater core

- Refer to [GI-11, "Components"](#) for symbol marks in the figure.

Removal and Installation

REMOVAL

NBS004RS

1. Remove engine room cover (RH and LH). Refer to [EM-173, "ENGINE ROOM COVER"](#) .
2. Remove engine cover with power tool. Refer to [EM-179, "INTAKE MANIFOLD"](#) .
3. Remove air duct (inlet). Refer to [EM-177, "AIR CLEANER AND AIR DUCT"](#) .
4. Drain engine coolant from drain plugs on radiator and both side of cylinder block. Refer to [CO-40, "Changing Engine Coolant"](#) and [EM-250, "DISASSEMBLY"](#) .

CAUTION:

- Perform this step when engine is cold.
- Do not spill engine coolant on drive belts.

5. Disconnect water suction hose from water inlet.
6. Remove water inlet and thermostat.

CAUTION:

Do not disassemble thermostat.

7. Remove intake manifolds (upper and lower). Refer to [EM-179, "INTAKE MANIFOLD"](#).
8. Disconnect radiator hose (upper) from thermostat housing.
9. Disconnect heater hoses from water outlet and heater pipe.
10. Remove thermostat housing, water outlet pipe, water connector, water control valve, water outlet and heater pipe.

CAUTION:

Do not disassemble water control valve.

INSPECTION AFTER REMOVAL

- Make sure that valves both in thermostat and water control valve are completely closing at normal temperature.
- Place a thread so that it is caught in the valves of the thermostat and water control valve. Immerse fully in a container filled with water. Heat while stirring. (The example in the figure shows thermostat.)
- The valve opening temperature is the temperature at which the valve opens and falls from the thread.
- Continue heating. Check the maximum valve lift.

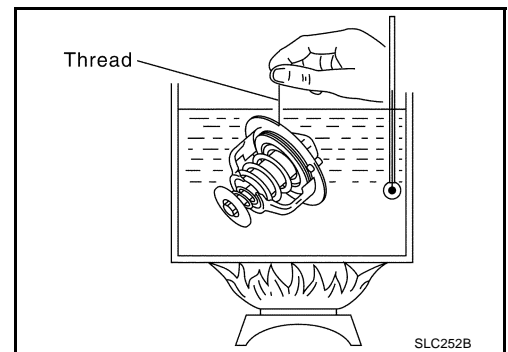

NOTE:

The maximum valve lift standard temperature for water control valve is the reference value.

- After checking the maximum valve lift, lower the water temperature and check the valve closing temperature.

Standard values:

	Thermostat	Water control valve
Valve opening temperature	80 - 84°C (176 - 183°F)	93.5 - 96.5°C (200 - 206°F)
Maximum valve lift	More than 10 mm/ 95°C (0.39 in/ 203°F)	More than 8 mm/ 108°C (0.315 in/ 226°F)
Valve closing temperature	77°C (171°F)	90°C (194°F)

- If the malfunctioning condition, when closing valve at normal temperature, or measured values are out of the standard, replace thermostat and/or water control valve.

INSTALLATION

Note the following, and install in the reverse order of removal.

CAUTION:

Be careful not to spill engine coolant over engine room. Use rag to absorb engine coolant.

Thermostat and Water Control Valve

- Install thermostat and water control valve with the whole circumference of each flange part fit securely inside rubber ring. (The example in the figure shows thermostat.)

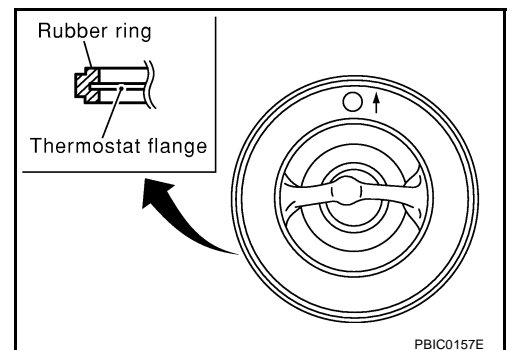

THERMOSTAT AND WATER CONTROL VALVE

[VK45DE]

- Install thermostat with jiggle valve facing upwards. (The position deviation may be within the range of ± 10 degrees)
- Install water control valve with the up-mark facing up and the frame center part facing upwards. (The position deviation may be within the range of ± 10 degrees)

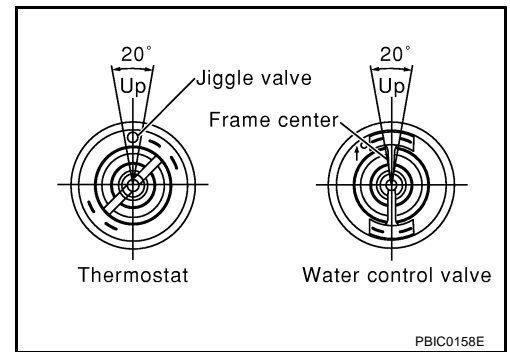

Water Outlet Pipe and Heater Pipe

First apply a neutral detergent to O-rings, then quickly insert the insertion parts of the water outlet pipe and heater pipe into the installation holes.

INSPECTION AFTER INSTALLATION

- Check for leaks of engine coolant using radiator cap tester adapter [SST: EG17650301 (J33984-A)] and radiator cap tester (commercial service tool). Refer to [CO-40, "LEAK CHECK"](#).
- Start and warm up engine. Visually check if there is no leaks of engine coolant.

A
CO
C
D
E
F
G
H
I
J
K
L
M

SERVICE DATA AND SPECIFICATIONS (SDS)

[VK45DE]

SERVICE DATA AND SPECIFICATIONS (SDS)

PFP:00030

Standard and Limit ENGINE COOLANT CAPACITY (APPROXIMATE)

NBS004RT

Unit: ℓ (US qt, Imp qt)

Engine coolant capacity (With reservoir tank at "MAX" level)	10.4 (11, 9-1/8)
Reservoir tank engine coolant capacity (at "MAX" level)	0.6 (5/8, 1/2)

RADIATOR

Unit: kPa (kg/cm², psi)

Radiator cap relief pressure	Standard	78 - 98 (0.8 - 1.0, 11 - 14)
	Limit	59 (0.6, 9)
Leakage testing pressure		157 (1.6, 23)

THERMOSTAT

Thermostat	Standard
Valve opening temperature	80 - 84°C (176 - 183°F)
Maximum valve lift	More than 10 mm/ 95°C (0.39 in/ 203°F)
Valve closing temperature	77°C (171°F)

WATER CONTROL VALVE

Water control valve	Standard
Valve opening temperature	93.5 - 96.5°C (200 - 206°F)
Maximum valve lift	More than 8 mm/ 108°C (0.315 in/ 226°F)
Valve closing temperature	90°C (194°F)