

A
B
C
D

WT

SECTION

ROAD WHEELS & TIRES

CONTENTS

WT

<p>PRECAUTIONS 3</p> <p style="padding-left: 20px;">Precautions 3</p> <p>PREPARATION 4</p> <p style="padding-left: 20px;">Special Service Tools [SST] 4</p> <p style="padding-left: 20px;">Commercial Service Tools 4</p> <p>NOISE, VIBRATION AND HARSHNESS (NVH)</p> <p>TROUBLESHOOTING 5</p> <p style="padding-left: 20px;">NVH Troubleshooting Chart 5</p> <p>ROAD WHEEL 6</p> <p style="padding-left: 20px;">Inspection 6</p> <p style="padding-left: 40px;">ALUMINUM WHEEL 6</p> <p style="padding-left: 40px;">STEEL WHEEL 6</p> <p>ROAD WHEEL TIRE ASSEMBLY 7</p> <p style="padding-left: 20px;">Balancing Wheels (Bonding Weight Type) 7</p> <p style="padding-left: 20px;">REMOVAL 7</p> <p style="padding-left: 20px;">WHEEL BALANCE ADJUSTMENT 7</p> <p style="padding-left: 20px;">Rotation 8</p> <p>LOW TIRE PRESSURE WARNING SYSTEM 9</p> <p style="padding-left: 20px;">System Components 9</p> <p style="padding-left: 20px;">System Description 9</p> <p style="padding-left: 40px;">TRANSMITTER 9</p> <p style="padding-left: 40px;">RECEIVER 10</p> <p style="padding-left: 20px;">LOW TIRE PRESSURE WARNING CONTROL UNIT 10</p> <p style="padding-left: 20px;">LOW TIRE PRESSURE WARNING LAMP 10</p> <p style="padding-left: 20px;">DISPLAY UNIT 11</p> <p>CAN COMMUNICATION 12</p> <p style="padding-left: 20px;">System Description 12</p> <p>TROUBLE DIAGNOSES 13</p> <p style="padding-left: 20px;">How to Perform Trouble Diagnoses 13</p> <p style="padding-left: 40px;">BASIC CONCEPT 13</p> <p style="padding-left: 20px;">Schematic 14</p> <p style="padding-left: 20px;">Wiring Diagram — T/WARN — 15</p> <p style="padding-left: 20px;">Control Unit Input/Output Signal Standard 18</p> <p style="padding-left: 20px;">ID Registration Procedure 19</p> <p style="padding-left: 40px;">ID REGISTRATION WITH ACTIVATION TOOL.. 19</p> <p style="padding-left: 40px;">ID REGISTRATION WITHOUT ACTIVATION TOOL 20</p> <p style="padding-left: 20px;">Transmitter Wake Up Operation 21</p> <p style="padding-left: 40px;">WITH TRANSMITTER ACTIVATION TOOL 21</p>	<p>CONSULT-II Function (AIR PRESSURE MONITOR) 21</p> <p style="padding-left: 20px;">FUNCTION 21</p> <p style="padding-left: 20px;">CONSULT-II SETTING PROCEDURE 21</p> <p style="padding-left: 20px;">WORK SUPPORT MODE 22</p> <p style="padding-left: 20px;">SELF-DIAG RESULT MODE 22</p> <p style="padding-left: 20px;">DATA MONITOR MODE 23</p> <p style="padding-left: 20px;">ACTIVE TEST MODE 23</p> <p style="padding-left: 20px;">LOW TIRE PRESSURE WARNING CONTROL UNIT PART NUMBER 24</p> <p>Diagnosis Procedure with Warning Lamp Function (Without CONSULT-II) 24</p> <p style="padding-left: 20px;">DESCRIPTION 24</p> <p style="padding-left: 20px;">FUNCTION 24</p> <p style="padding-left: 20px;">LOW TIRE PRESSURE WARNING LAMP DIAGNOSTIC CHART 24</p> <p>How to Perform Trouble Diagnosis for Quick and Accurate Repair 26</p> <p style="padding-left: 20px;">INTRODUCTION 26</p> <p style="padding-left: 20px;">WORK FLOW 26</p> <p style="padding-left: 20px;">Preliminary Check 27</p> <p style="padding-left: 20px;">Trouble Diagnosis Chart 28</p> <p style="padding-left: 40px;">SELF-DIAGNOSIS 28</p> <p style="padding-left: 40px;">DIAGNOSIS CHART BY SYMPTOM 29</p> <p>TROUBLE DIAGNOSIS FOR SELF-DIAGNOSTIC ITEMS 30</p> <p style="padding-left: 20px;">Inspection 1: Transmitter no Data 30</p> <p style="padding-left: 40px;">MALFUNCTION CODE NO. 21, 22, 23, 24 30</p> <p style="padding-left: 20px;">Inspection 2: Receiver Data Error 31</p> <p style="padding-left: 40px;">MALFUNCTION CODE NO. 25, 26, 27, 28 31</p> <p style="padding-left: 20px;">Inspection 3: Transmitter Pressure Data Error 32</p> <p style="padding-left: 40px;">MALFUNCTION CODE NO. 35, 36, 37, 38 32</p> <p style="padding-left: 20px;">Inspection 4: Transmitter Function Code Error 32</p> <p style="padding-left: 40px;">MALFUNCTION CODE NO. 41, 42, 43, 44 32</p> <p style="padding-left: 20px;">Inspection 5: Transmitter Battery Voltage Low 33</p> <p style="padding-left: 40px;">MALFUNCTION CODE NO. 45, 46, 47, 48 33</p> <p style="padding-left: 20px;">Inspection 6: Receiver ID No Registration 33</p> <p style="padding-left: 40px;">MALFUNCTION CODE NO. 51 33</p> <p style="padding-left: 20px;">Inspection 7: Vehicle Speed Signal 34</p>
--	---

F

G

H

I

J

K

L

M

MALFUNCTION CODE NO. 52	34	REMOVAL AND INSTALLATION	39
Inspection 8: CAN Communication System Mal- function	34	Transmitter	39
TROUBLE DIAGNOSIS FOR SYMPTOMS	35	REMOVAL	39
Inspection 1: Warning Lamp Does Not Come On When Ignition Switch Is Turned On	35	INSTALLATION	39
Inspection 2: Warning Lamp Stays On When Ignition Switch Is Turned On	36	Low Tire Pressure Warning Control Unit	40
Inspection 3: Warning Lamp Blinks When Ignition Switch Is Turned On	37	REMOVAL	40
Inspection 4: Turn Signal Lamp Blinks When Ignition Switch Is Turned On	37	INSTALLATION	40
Inspection 5: ID Registration Can Not Be Completed..	38	Receiver	40
		REMOVAL	40
		INSTALLATION	40
		SERVICE DATA AND SPECIFICATIONS (SDS)	41
		Road Wheel	41
		Tire	41

PRECAUTIONS

PRECAUTIONS

PPF:00001

Precautions

NES000JK

ID registration is required when replacing or rotating wheels.

A

B

C

D

WT

F

G

H

I

J

K

L

M

PREPARATION

PREPARATION

PFP:00002

Special Service Tools [SST]

NES000JL

The actual shapes of Kent-Moore tools may differ from those of special service tools illustrated here.

Tool number (Kent-Moore No.) Tool name	Description
(J-45295) Activation tool	ID registration

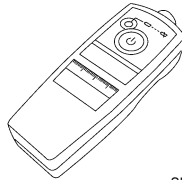

SEIA0462E

Commercial Service Tools

NES000JM

Tool name	Description
Power tool	Removing wheel nuts

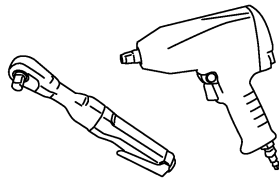

PBIC0190E

NOISE, VIBRATION AND HARSHNESS (NVH) TROUBLESHOOTING

NOISE, VIBRATION AND HARSHNESS (NVH) TROUBLESHOOTING

PPF:00003

NVH Troubleshooting Chart

NES000JN

Use chart below to help you find the cause of the symptom. If necessary, repair or replace these parts.

Reference page		FAX-5, FSU-6	WT-6	WT-7	WT-41	WT-8	—	—	WT-41	NVH in PR section.	NVH in RFD section.	NVH in FAX and FSU sections.	NVH in RAX and RSU sections.	Refer to TIRES in this chart.	Refer to ROAD WHEEL in this chart.	NVH in FAX, RAX section.	NVH in BR section.	NVH in PS section.			
Possible cause and SUSPECTED PARTS		Improper installation, looseness	Out-of-round	Imbalance	Incorrect tire pressure	Uneven tire wear	Deformation or damage	Non-uniformity	Incorrect tire size	PROPELLER SHAFT	DIFFERENTIAL	FRONT AXLE AND FRONT SUSPENSION	REAR AXLE AND REAR SUSPENSION	TIRES	ROAD WHEELS	DRIVE SHAFT	BRAKE	STEERING			
Symptom	TIRES	Noise	x	x	x	x	x	x	x	x	x	x	x	x	x	x	x	x			
		Shake	x	x	x	x	x	x	x	x	x	x	x	x	x	x	x	x	x		
		Vibration	x	x	x	x	x	x	x	x	x	x	x	x	x	x	x	x	x	x	
		Shimmy	x	x	x	x	x	x	x	x	x	x	x	x	x	x	x	x	x	x	
		Judder	x	x	x	x	x	x	x	x	x	x	x	x	x	x	x	x	x	x	x
		Poor quality ride or handling	x	x	x	x	x	x	x	x	x	x	x	x	x	x	x	x	x	x	x
	ROAD WHEEL	Noise	x	x	x	x	x	x	x	x	x	x	x	x	x	x	x	x	x	x	
		Shake	x	x	x	x	x	x	x	x	x	x	x	x	x	x	x	x	x	x	x
Shimmy, Judder		x	x	x	x	x	x	x	x	x	x	x	x	x	x	x	x	x	x	x	
Poor quality ride or handling		x	x	x	x	x	x	x	x	x	x	x	x	x	x	x	x	x	x	x	

x: Applicable

A
B
C
D
WT
F
G
H
I
J
K
L
M

ROAD WHEEL

ROAD WHEEL

PFP:40300

Inspection ALUMINUM WHEEL

NES000JO

1. Check tires for wear and improper inflation.
2. Check wheels for deformation, cracks and other damage. If deformed, remove wheel and check wheel runout.
 - a. Remove tire from aluminum wheel and mount on a tire balance machine.
 - b. Set dial indicator as shown in the figure.

Wheel runout (Dial indicator value):

Refer to [WT-41, "SERVICE DATA AND SPECIFICATIONS \(SDS\)"](#) .

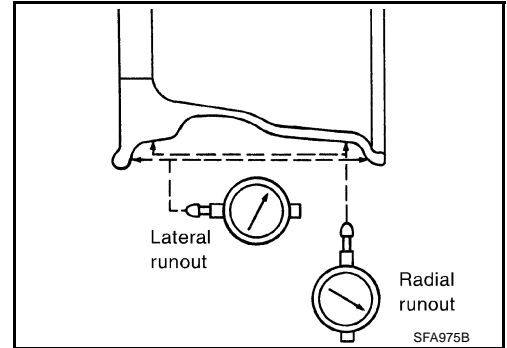

STEEL WHEEL

1. Check tires for wear and improper inflation.
2. Check wheels for deformation, cracks and other damage. If deformed, remove wheel and check wheel runout.
 - a. Remove tire from steel wheel and mount on a tire balance machine.
 - b. Set two dial indicators as shown in the figure.
 - c. Set each dial indicator to 0.
 - d. Rotate wheel and check dial indicators at several points around the circumference of the wheel.
 - e. Calculate runout at each point as shown below.

Radial runout = (A+B)/2

Lateral runout = (C+D)/2

- f. Select maximum positive runout value and the maximum negative value. Add the two values to determine total runout. In case a positive or negative value is not available, use the maximum value (negative or positive) for total runout. If the total runout value exceeds the limit, replace steel wheel.

Wheel runout : Refer to [WT-41, "SERVICE DATA AND SPECIFICATIONS \(SDS\)"](#) .

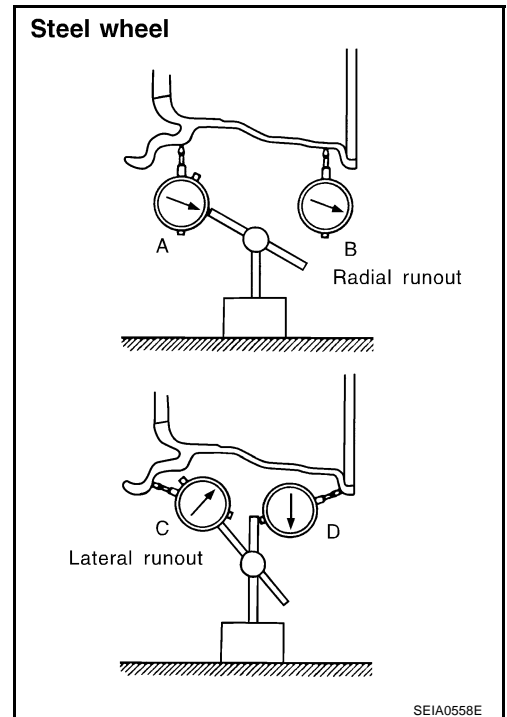

ROAD WHEEL TIRE ASSEMBLY

ROAD WHEEL TIRE ASSEMBLY

PPF:40300

Balancing Wheels (Bonding Weight Type) REMOVAL

NES000JP

1. Using releasing agent, remove double-faced adhesive tape from the road wheel.

CAUTION:

- Be careful not to scratch the road wheel during removal.
- After removing double-faced adhesive tape, wipe clean traces of releasing agent from the road wheel.

WHEEL BALANCE ADJUSTMENT

If a tire balance machine has adhesion balance weight mode settings and drive-in weight mode setting, select and adjust a drive-in weight mode suitable for road wheels.

1. Set road wheel on wheel balancer using the center hole as a guide. Start the tire balance machine.
2. When inner and outer unbalance values are shown on the tire balance machine indicator, multiply outer unbalance value by $5/3$ to determine balance weight that should be used. Select the outer balance weight with a value closest to the calculated value above and install it to the designated outer position of, or at the designated angle in relation to the road wheel.

CAUTION:

- Do not install the inner balance weight before installing the outer balance weight.
- Before installing the balance weight, be sure to clean the mating surface of the road wheel.

Indicated imbalance value $\times 5/3 =$ balance weight to be installed.

$23 \text{ g (0.81 oz)} \times 5/3 = 38.33 \text{ g (1.35 oz)} = 40 \text{ g (1.41 oz)}$ balance weight (closer to calculated balance weight value)

Note that balance weight value must be closer to the calculated balance weight value.

$37.4 = 35 \text{ g (1.23 oz)}$

$37.5 = 40 \text{ g (1.41 oz)}$

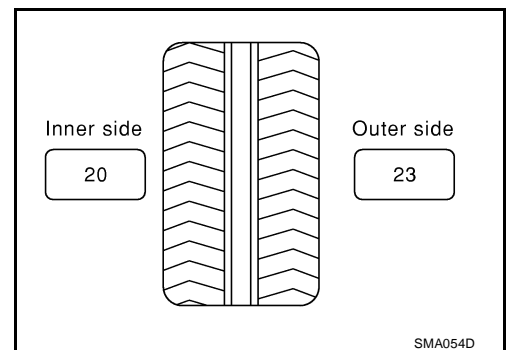

- a. Install balance weight in the position shown in the figure.
- b. When installing balance weight to road wheels, set it into the grooved area on the inner wall of the road wheel as shown in the figure so that the balance weight center is aligned with the wheel balancer indication position (angle).

CAUTION:

- Always use genuine NISSAN adhesion balance weights.
- Balance weights are un reusable; always replace with new ones.
- Do not install more than three sheets of balance weight.

- c. If calculated balance weight value exceeds 50 g (1.76 oz), install two balance weight sheets in line with each other as shown in the figure.

CAUTION:

Do not install one balance weight sheet on top of another.

3. Start wheel balancer again.
4. Install drive-in balance weight on inner side of road wheel in the wheel balancer indication position (angle).

CAUTION:

Do not install more than two balance weights.

5. Start wheel balancer. Make sure that inner and outer residual imbalance value are 7 g (0.25 oz) each or below.

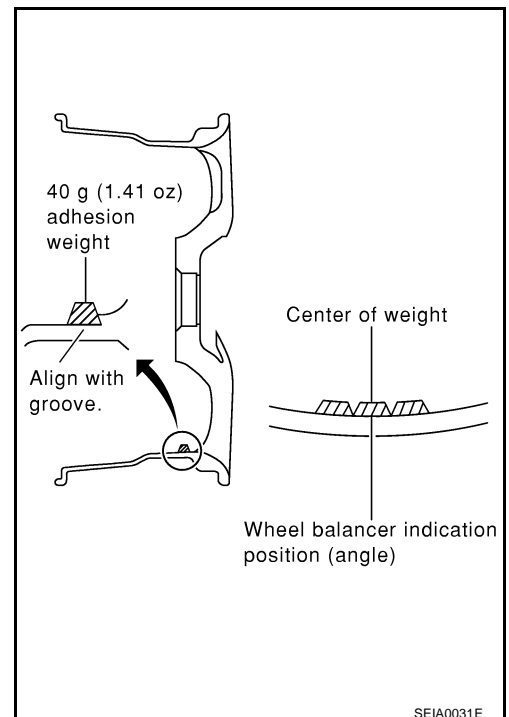

ROAD WHEEL TIRE ASSEMBLY

- If either residual imbalance value exceeds 7 g (0.25 oz), repeat installation procedures.

Maximum allowable unbalance	Dynamic (At rim flange)	Less than 7 g (0.25 oz) (one side)
	Static (At flange)	Less than 14 g (0.49 oz)

Rotation

NES000JQ

- Follow the maintenance schedule for tire rotation service intervals. Refer to [MA-7, "PERIODIC MAINTENANCE"](#).
- Do not include the T-type spare tire when rotating the tires.

CAUTION:

- When installing wheels, tighten them diagonally by dividing the work two to three times in order to prevent the wheels from developing any distortion.
- Be careful not to tighten wheel nut at torque exceeding the criteria for preventing strain of disc rotor.

**Tightening torque : 108 N·m (11 kg·m, 80 ft·lb)
of wheel nut**

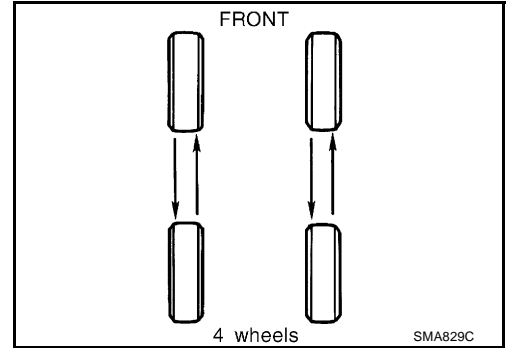

LOW TIRE PRESSURE WARNING SYSTEM

LOW TIRE PRESSURE WARNING SYSTEM

PPF:40300

System Components

NES000JR

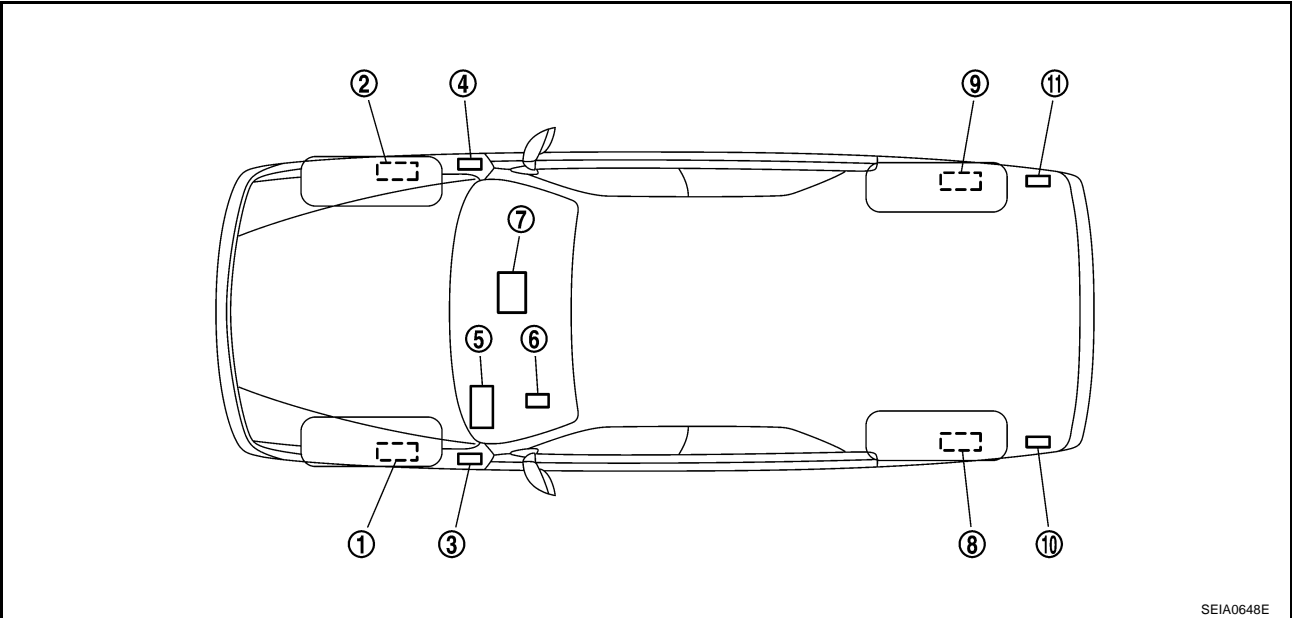

- | | | |
|---------------------------------------|---|--------------------------------------|
| 1. Tire pressure transmitter front LH | 2. Tire pressure transmitter front RH | 3. Tire pressure receiver front LH |
| 4. Tire pressure receiver front RH | 5. Low tire pressure warning control unit | 6. Low tire pressure warning lamp |
| 7. Display unit | 8. Tire pressure transmitter rear LH | 9. Tire pressure transmitter rear RH |
| 10. Tire pressure receiver rear LH | 11. Tire pressure receiver rear RH | |

System Description

TRANSMITTER

NES000JS

A sensor-transmitter integrated with a valve is installed on a wheel, and transmits a detected air pressure signal in the form of a radio wave.

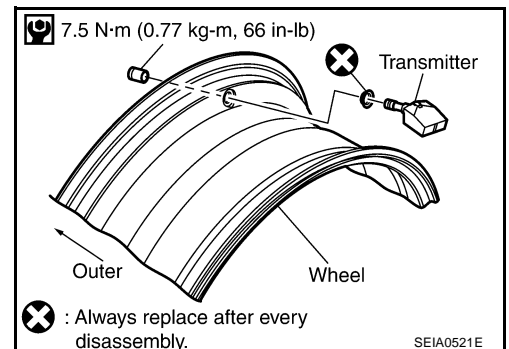

LOW TIRE PRESSURE WARNING SYSTEM

RECEIVER

The receiver receives the air pressure signal transmitted by the transmitter in each wheel.

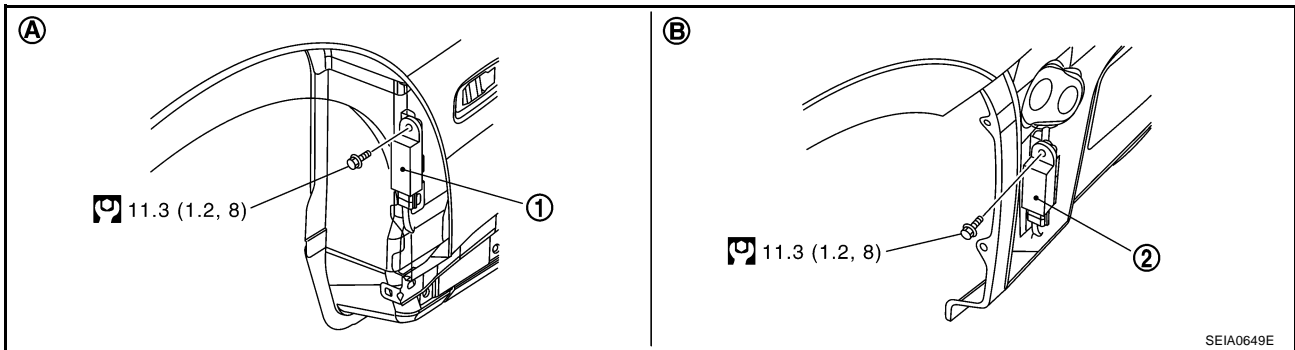

1. Tire pressure receiver front 2. Tire pressure receiver rear A. Front wheel house
 B. Rear wheel house

Refer to [GI-11, "Components"](#), for the symbols in the figure.

LOW TIRE PRESSURE WARNING CONTROL UNIT

The low tire pressure warning control unit (1) reads the air pressure signal received by the receiver, and controls the low tire pressure warning lamp and the buzzer operations. It also has a judgement function to detect a system malfunction.

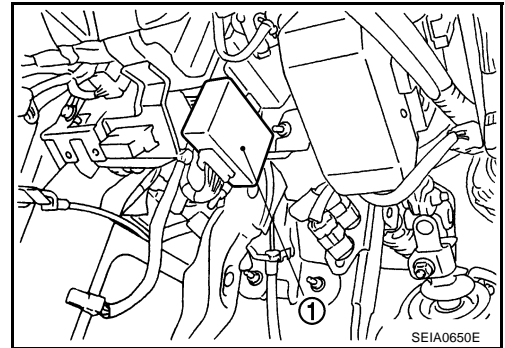

LOW TIRE PRESSURE WARNING LAMP

The combination meter receives tire pressure status from the low tire pressure warning control unit using CAN communication. When a low tire pressure condition is sensed by the low tire pressure control unit, the combination meter low tire pressure warning lamp and buzzer are activated.

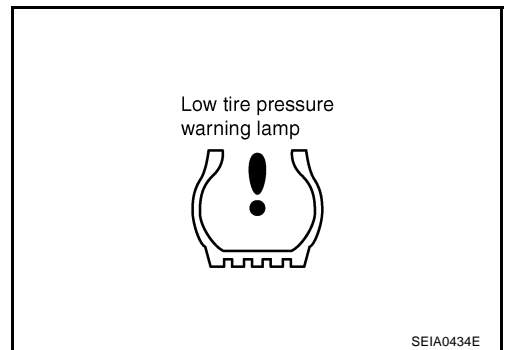

Low Tire Pressure Warning Lamp Indication

Condition	Low tire pressure warning lamp	Buzzer
Less than 186 kPa (1.86 kg/cm ² , 27 psi) [Flat tire]*	ON	Sounds for 10 sec.
Low tire pressure warning system malfunction [Other diagnostic item]	Warning lamp flashes 1 min, then turns ON	OFF

*: Standard air pressure is for 230 kpa (2.3 kg/cm², 33 psi) vehicle.

LOW TIRE PRESSURE WARNING SYSTEM

DISPLAY UNIT

Display the air pressure of each tire.

- After the ignition switch is turned ON, the pressure values are not be displayed until the data of all four wheels stabilizes.

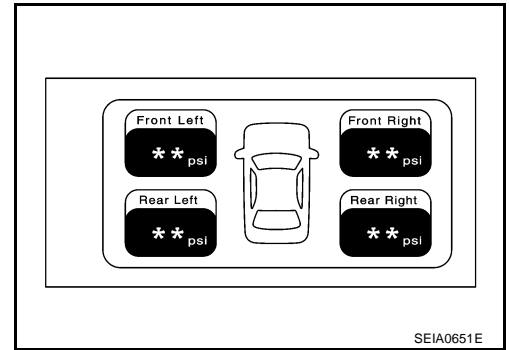

A
B
C
D

WT

F
G
H
I
J
K
L
M

CAN COMMUNICATION

PFP:23710

System Description

NES000JT

CAN (Controller Area Network) is a serial communication line for real time application. It is an on-vehicle multiplex communication line with high data communication speed and excellent error detection ability. Many electronic control units are equipped onto a vehicle, and each control unit shares information and links with other control units during operation (not independent). In CAN communication, control units are connected with 2 communication lines (CAN H line, CAN L line) allowing a high rate of information transmission with less wiring. Each control unit transmits/receives data but selectively reads required data only.

Refer to [LAN-34. "CAN COMMUNICATION"](#) .

TROUBLE DIAGNOSES

PFP:00004

How to Perform Trouble Diagnoses BASIC CONCEPT

NES000JU

- The most important point to perform trouble diagnosis is to understand systems (control and mechanism) in vehicle thoroughly.

- It is also important to clarify customer complaints before inspection.

First of all, reproduce symptom, and understand it fully.

Ask customer about his/her complaints carefully. In some cases, they will be necessary to check symptom by driving vehicle with customer.

CAUTION:

Customers are not professionals. Do not assume “maybe customer means...” or “maybe the customer mentioned this symptom”.

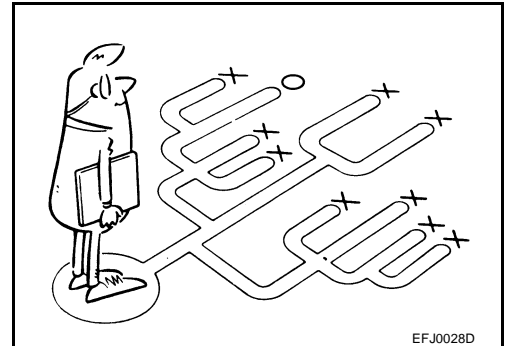

- It is essential to check symptoms right from beginning in order to repair a malfunction completely.

For an intermittent malfunction, it is important to reproduce symptom based on interview with customer and past examples. Do not perform inspection on ad hoc basis. Most intermittent malfunctions are caused by poor contacts. In this case, it will be effective to shake suspected harness or connector by hand. When repairs are performed without any symptom check, no one can judge if malfunction has actually been eliminated.

- Always diagnosis, make sure to perform “ERASE MEMORY”.
- Always read “GI General information” to confirm general precautions. Refer to [GI-4, "General Precautions"](#) .

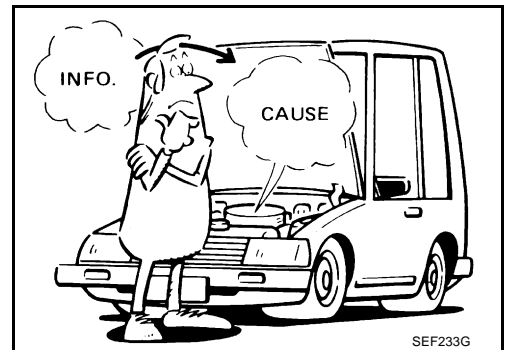

A

B

C

D

WT

F

G

H

I

J

K

L

M

TROUBLE DIAGNOSES

Schematic

NES000JV

(NV) : With navigation system
 (ON) : Without navigation system

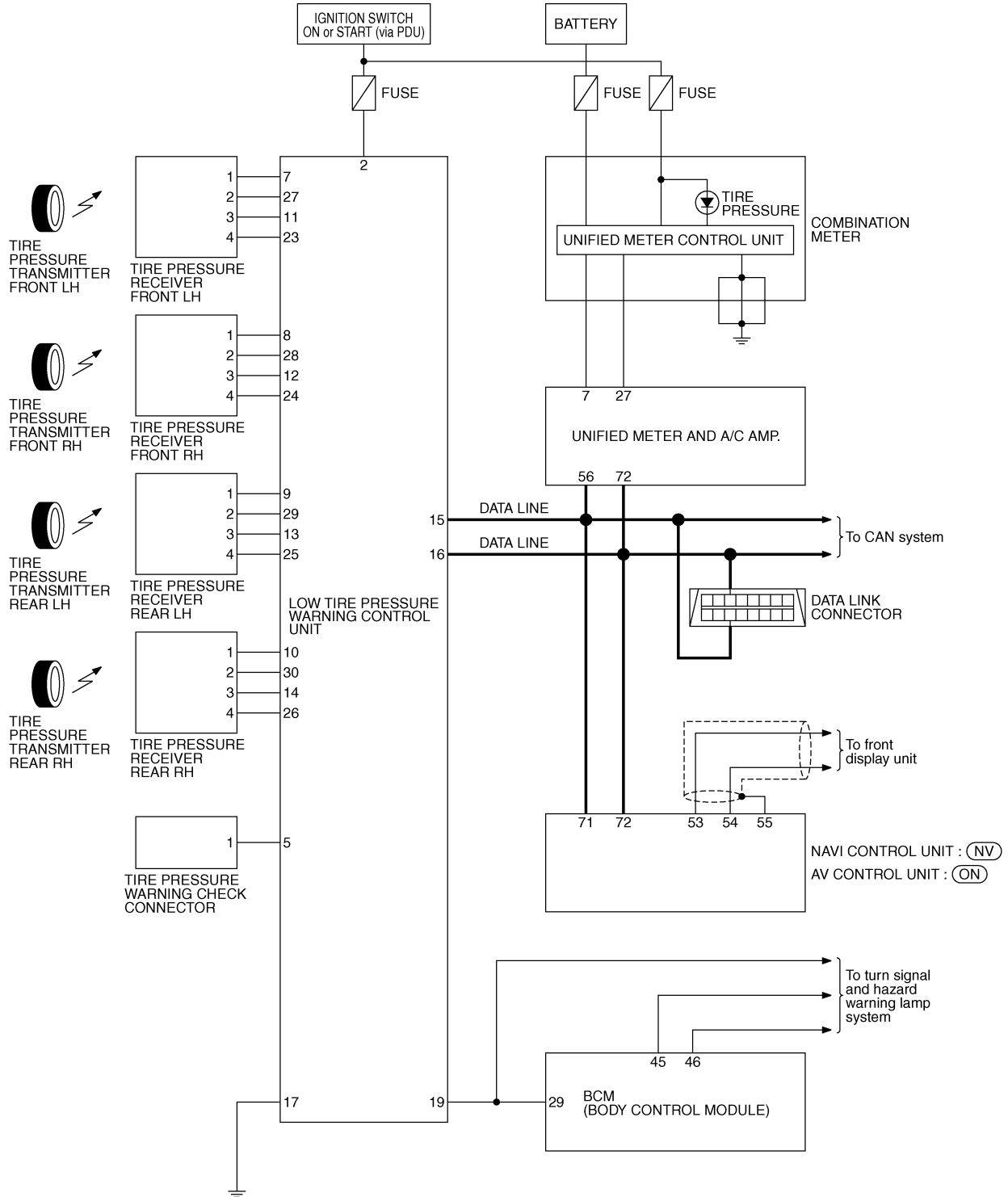

TEWT0026E

TROUBLE DIAGNOSES

Wiring Diagram — T/WARN —

NES000JW

WT-T/WARN-01

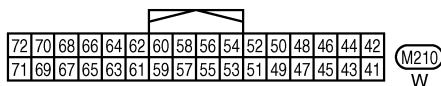
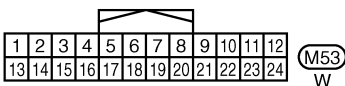
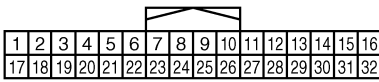
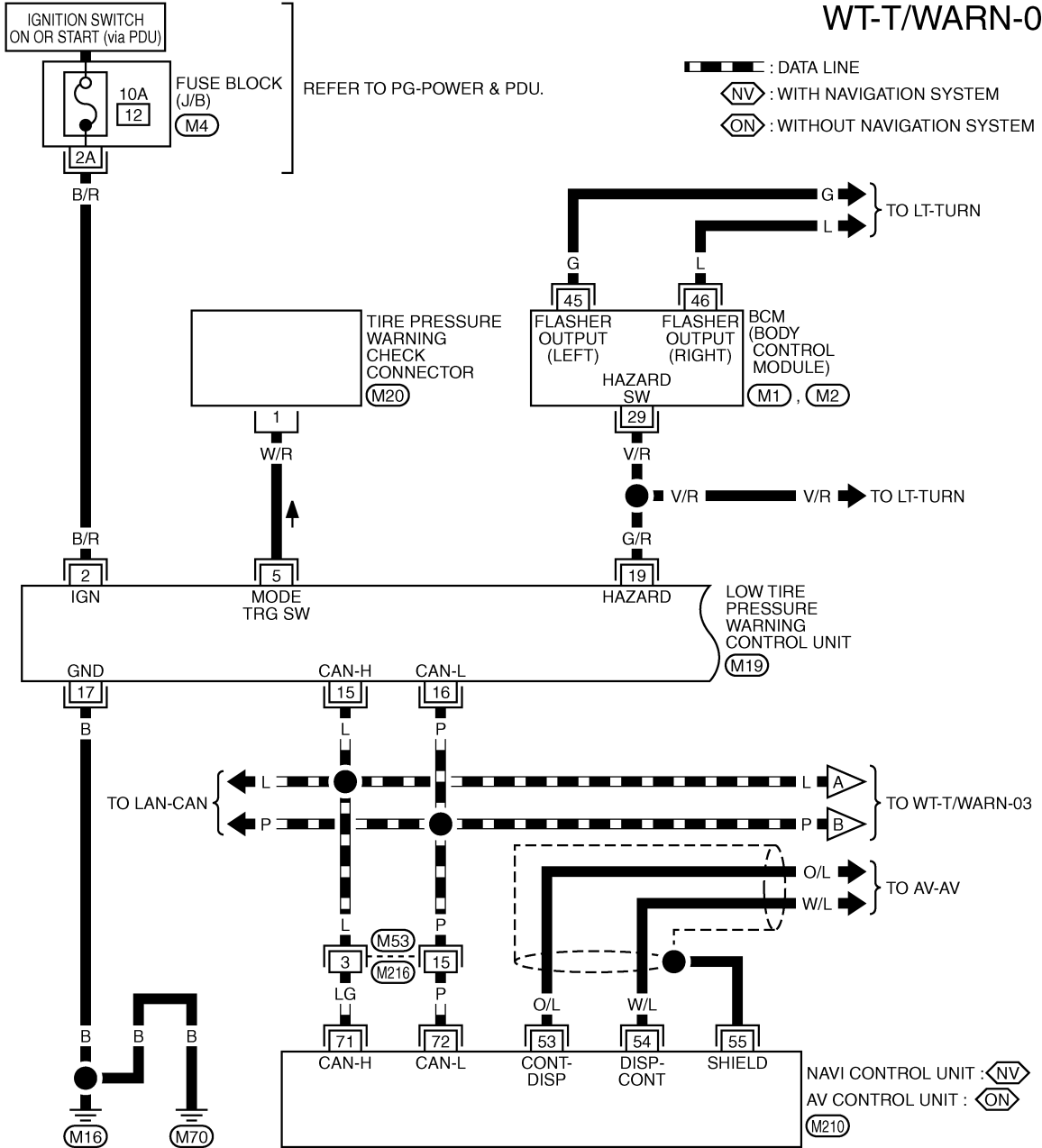

REFER TO THE FOLLOWING.

- (M4) - FUSE BLOCK-JUNCTION BOX (J/B)
- (M1), (M2) - ELECTRICAL UNITS

TEWT0027E

TROUBLE DIAGNOSES

WT-T/WARN-02

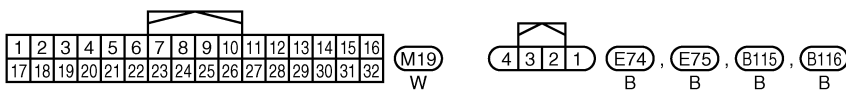
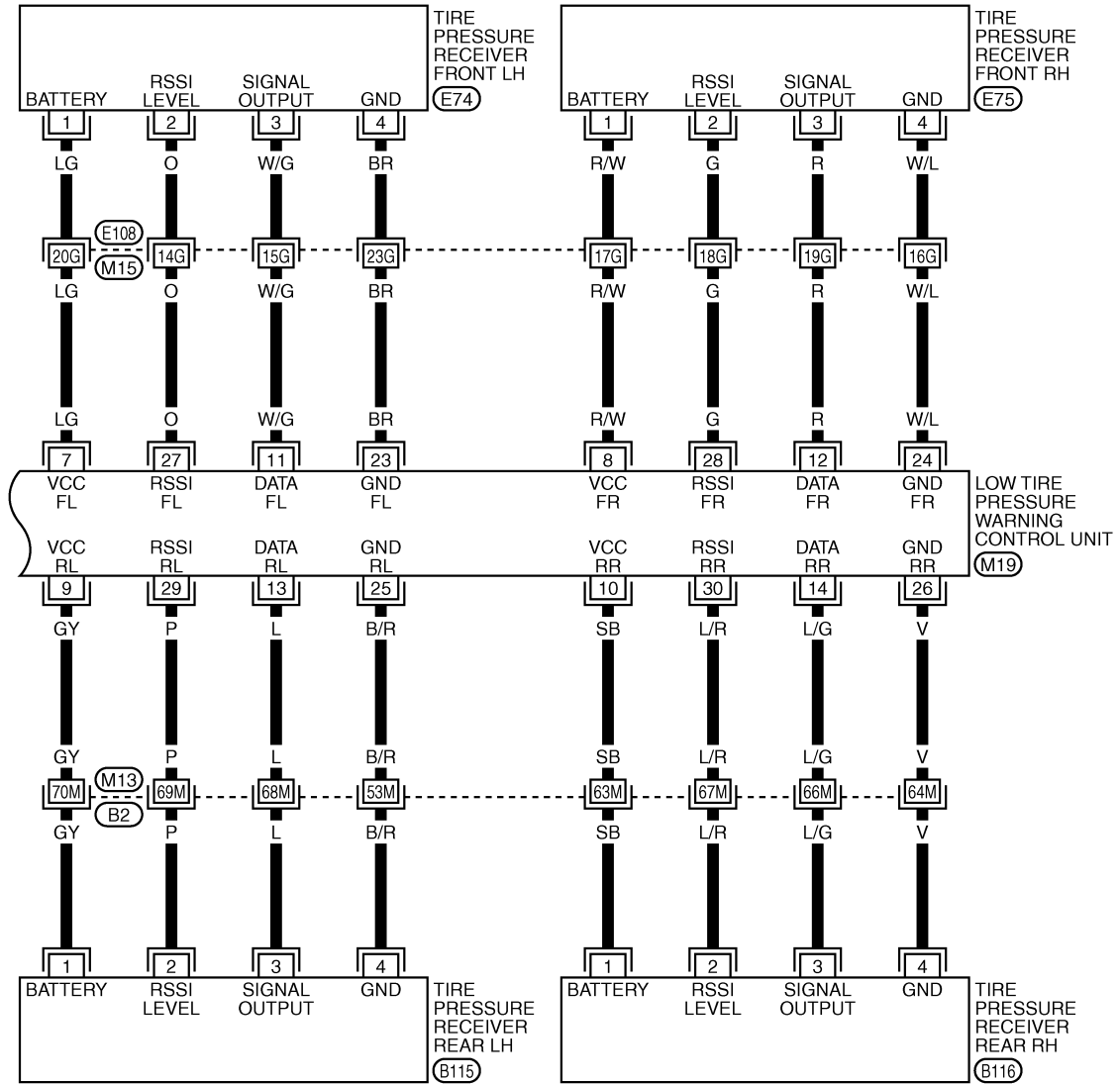

REFER TO THE FOLLOWING.
 (E108), (B2) -SUPER MULTIPLE
 JUNCTION (SMJ)

TEWT0028E

TROUBLE DIAGNOSES

WT-T/WARN-03

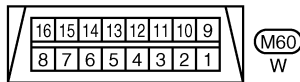
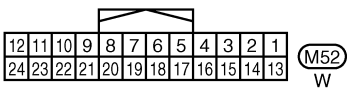
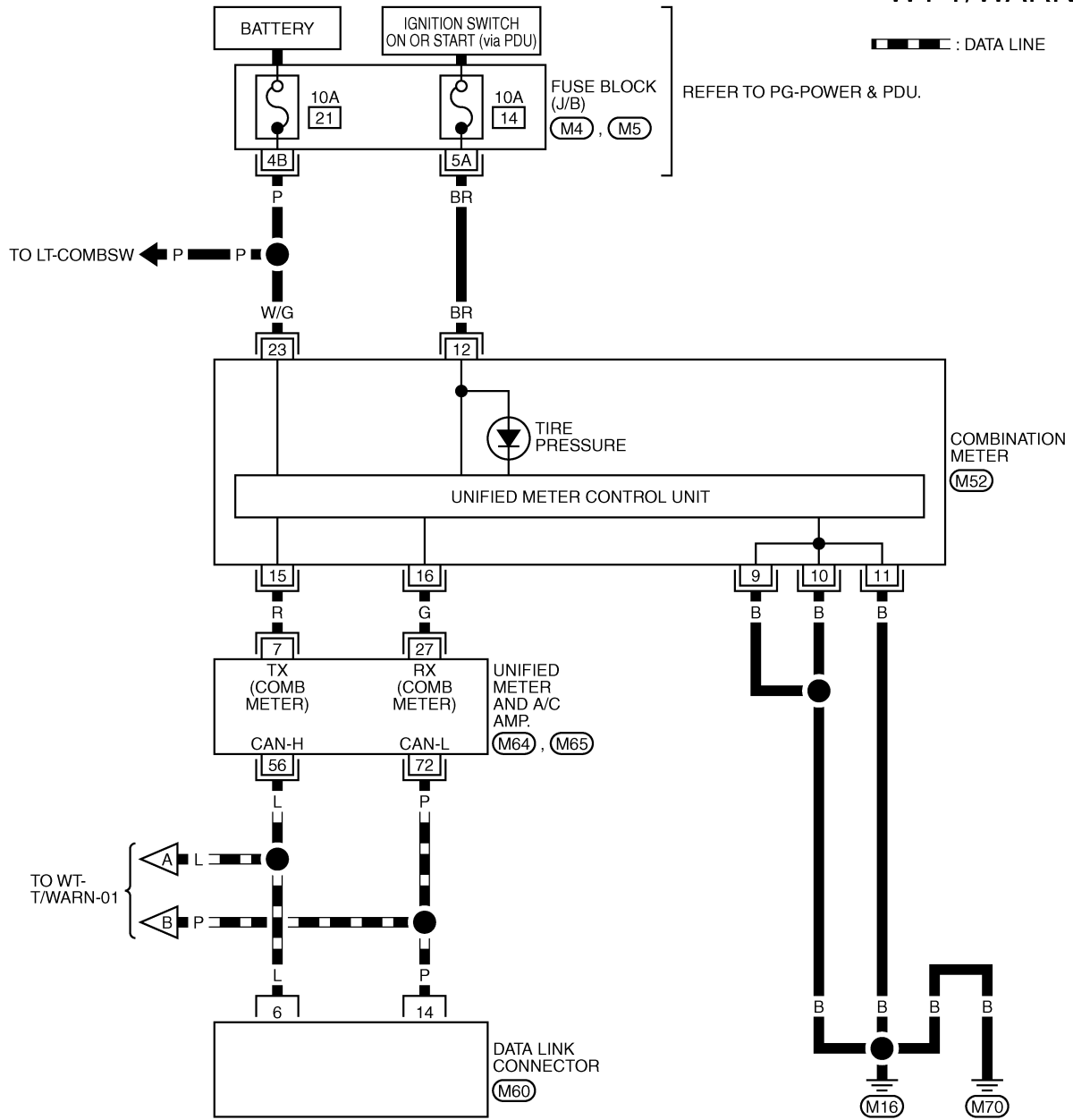

REFER TO THE FOLLOWING.
(M4), (M5) - FUSE BLOCK-JUNCTION BOX (J/B)

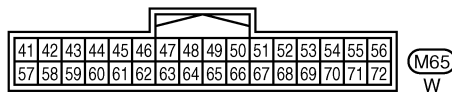
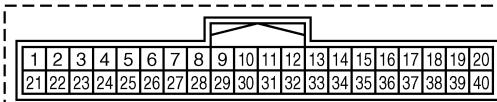

TROUBLE DIAGNOSES

Control Unit Input/Output Signal Standard

NES000JX

CAUTION:

When checked using a circuit tester for voltage measurement, connector terminals should not be forcefully extended.

Terminal		Measuring point	Measuring condition	Standard
+	-			
2 (B/R)	Ground	Ignition switch	Ignition switch ON	Battery voltage (12 V)
5 (W/R)		Tire pressure warning check connector	Always	Approx. 5 V
7 (LG)		Battery power supply	Ignition switch ON	Battery voltage (12 V)
8 (R/W)				
9 (GY)				
10 (SB)				
11 (W/G)		Signal Input	Ignition switch ON	Approx. 4.5 V
12 (R)				
13 (L)				
14 (L/G)				
15 (L)		Data line (CAN-H)	—	—
16 (P)		Data line (CAN-L)	—	—
17 (B)		Ground	—	0 V
19 (G/R)		Hazard	Hazard lamp switch OFF	Battery voltage (Approx. 12 V)
			Hazard lamp switch ON	0 V
23 (BR)		Ground	—	0 V
24 (W/L)			—	0 V
25 (B/R)			—	0 V
26 (V)			—	0 V
27 (O)		Analog signal	Ignition switch ON	Approx. 0.7 V
28 (G)				
29 (P)				
30 (L/R)				

TROUBLE DIAGNOSES

NES000JY

ID Registration Procedure ID REGISTRATION WITH ACTIVATION TOOL

This procedure must be done after replacement of a tire pressure transmitter, low tire pressure warning control unit, or tire rotation.

CAUTION:

If CONSULT-II is used with no connection of CONSULT-II CONVERTER, malfunction might be detected during self-diagnosis depending on control unit which performs CAN communication.

1. Turn ignition switch OFF.
2. Connect CONSULT-II and CONSULT-II CONVERTER to data link connector.
3. Turn ignition switch ON.
4. Touch "START (NISSAN BASED VHCL)" "AIR PRESSURE MONITOR".
 - If "AIR PRESSURE MONITOR" is not displayed, print the "SELECT SYSTEM" screen. Then refer to [LAN-7, "Precautions When Using CONSULT-II"](#)

NOTE:

Just after starting engine, or turning ignition switch ON, it may not be displayed even if "START (NISSAN BASED VHCL)" is touched. In this case, reconnect CONSULT-II and CONSULT-II CONVERTER.

5. Touch "WORK SUPPORT" on "SELECT DIAG MODE" screen.
6. Touch "ID REGIST" on "SELECT WORK ITEM".
7. With the activation tool [SST: J-45295] pushed against the front-left tire pressure transmitter position of the tire air valve, press and hold the button for 5 seconds.
8. Register the IDs in order from FR LH, FR RH, RR RH, RR LH. When ID registration of each wheel has been completed, a buzzer sounds and turn signal lamp blinks.

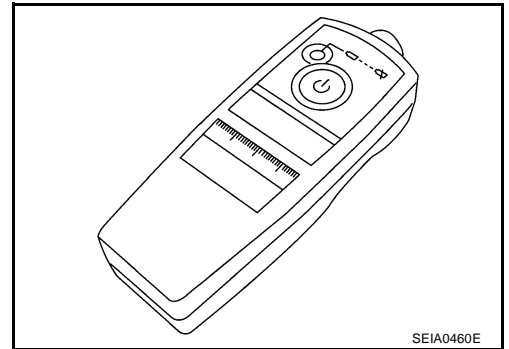

Activation tire position	Buzzer	Turn signal lamp	CONSULT-II
1 Front LH	Once	2 times flashing	"YET" ↓ "DONE"
2 Front RH	2 times		
3 Rear RH	3 times		
4 Rear LH	4 times		

9. After completing all ID registrations, press "END" to complete the procedure.

NOTE:

Be sure to register the IDs in order from FR LH, FR RH, RR RH, to RR LH, or the self-diagnosis results display will not function properly.

TROUBLE DIAGNOSES

ID REGISTRATION WITHOUT ACTIVATION TOOL

This procedure must be done after replacement of a tire pressure transmitter, low tire pressure warning control unit, or tire rotation.

CAUTION:

If CONSULT-II is used with no connection of CONSULT-II CONVERTER, malfunction might be detected during self-diagnosis depending on control unit which performs CAN communication.

1. Turn ignition switch OFF.
2. Connect CONSULT-II and CONSULT-II CONVERTER to data link connector.
3. Turn ignition switch ON.
4. Touch "START (NISSAN BASED VHCL)" "AIR PRESSURE MONITOR".
 - If "AIR PRESSURE MONITOR" is not displayed, print the "SELECT SYSTEM" screen. Then refer to [LAN-7, "Precautions When Using CONSULT-II"](#) .

NOTE:

Just after starting engine, or turning ignition switch ON, it may not be displayed even if "START (NISSAN BASED VHCL)" is touched. In this case, reconnect CONSULT-II and CONSULT-II CONVERTER.

5. Touch "WORK SUPPORT" on "SELECT DIAG MODE" screen.
6. Touch "ID REGIST" on "SELECT WORK ITEM".
7. Adjust the tire pressure to the values shown in the table below for ID registration, and drive the vehicle at 40 km/h (25 MPH) or more for a few minutes.

Tire position	Tire pressure kPa (kg/cm ² , psi)
Front – Left	240 (2.4, 34)
Front – Right	220 (2.2, 31)
Rear – Right	200 (2.0, 29)
Rear – Left	180 (1.8, 26)

8. After completing all ID registrations, press "END" to complete the procedure.

Activation tire position	CONSULT-II
Front LH	"YET" ↓ "DONE"
Front RH	
Rear RH	
Rear LH	

9. Inflate all tires to proper pressure. Refer to [WT-41, "SERVICE DATA AND SPECIFICATIONS \(SDS\)"](#) .

TROUBLE DIAGNOSES

Transmitter Wake Up Operation WITH TRANSMITTER ACTIVATION TOOL

NES000JZ

- With the activation tool [SST: J-45295] pushed against the front-left transmitter, press and hold the button for 5 seconds.
 - When ignition switch ON, as the low tire pressure warning lamp blinks per the follow diagram, the respective transmitter then must be woken up.

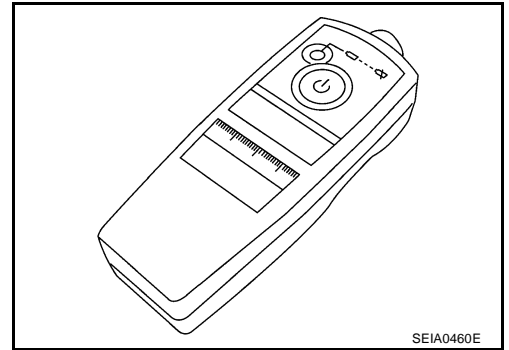

A
B
C
D

WT

Warning lamp blinking timing		Need to activation tire position	
ON OFF		a : 0.3sec b : 1.3sec	Front LH
ON OFF		a : 0.3sec b : 1.3sec	Front RH
ON OFF		a : 0.3sec b : 1.3sec	Rear RH
ON OFF		a : 0.3sec b : 1.3sec	Rear LH
ON OFF		a : 2sec b : 0.2sec	All tire

F
G
H
I

- Register the ID of wheel that warning lamp flashes. When wake up of registered wheel has been completed, turn signal lamp flashes two times.
- After completing wake up all transmitters, make sure low tire pressure warning lamp goes out.

SEIA0378E

CONSULT-II Function (AIR PRESSURE MONITOR) FUNCTION

NES000K0

CONSULT-II can display each diagnosis item using the diagnosis test modes shown following.

Mode	Function	Reference
WORK SUPPORT	This mode enables a technician to adjust some devices faster and more accurately by following the indications on CONSULT-II.	WT-22. "WORK SUPPORT MODE"
SELF-DIAG RESULTS	Receives self-diagnosis results from low tire pressure warning control unit and indicates DTCs.	WT-22. "SELF-DIAG RESULT MODE"
DATA MONITOR	Receives input/output signals from low tire pressure warning control unit and indicates and stores them to facilitate locating cause of malfunctions.	WT-23. "DATA MONITOR MODE"
CAN DIAG SUPPORT MNTR	Monitors transmitting/receiving status of CAN communication.	WT-12. "CAN COMMUNICATION"
ACTIVE TEST	Diagnostic Test Mode in with CONSULT-II drives some actuators apart from the low tire pressure warning control unit and also shifts some parameters in a specified range.	WT-23. "ACTIVE TEST MODE"
ECU PART NUMBER	Displays low tire pressure warning control unit part number.	WT-24. "LOW TIRE PRES-SURE WARNING CON-TROL UNIT PART NUMBER"

L
M

CONSULT-II SETTING PROCEDURE

Refer to [GI-39. "CONSULT-II Start Procedure"](#) .

TROUBLE DIAGNOSES

WORK SUPPORT MODE

Operation Procedure

1. Perform "CONSULT-II Start Procedure". Refer to [GI-39, "CONSULT-II Start Procedure"](#) .
2. Perform the "ID Regist". Refer to [WT-19, "ID Registration Procedure"](#) .

SELF-DIAG RESULT MODE

Operation Procedure

1. Perform "CONSULT-II Start Procedure". Refer to [GI-39, "CONSULT-II Start Procedure"](#) .
2. The self-diagnostic results are displayed. (Touch "PRINT" to print out the self-diagnostic results if necessary.) Check low tire pressure warning lamp if "NO FAILURE" is displayed.
3. Perform the appropriate inspection from the display item list, and repair or replace the malfunctioning component. Refer to [WT-22, "Display Item List"](#) .

Display Item List

DTC	Diagnostic item	Diagnostic item is detected when ...	Check items
C1700	FLAT_TIRE_FL	Front-left tire pressure drops to * kPa (* kg/cm ² , * psi) or less. (Notice)	—
C1701	FLAT_TIRE_FR	Front-right tire pressure drops to * kPa (* kg/cm ² , * psi) or less. (Notice)	
C1702	FLAT_TIRE_RR	Rear-right tire pressure drops to * kPa (* kg/cm ² , * psi) or less. (Notice)	
C1703	FLAT_TIRE_RL	Rear-left tire pressure drops to * kPa (* kg/cm ² , * psi) or less. (Notice)	
C1708	[NO_DATA]_FL	Data from front-left transmitter cannot be received.	WT-30
C1709	[NO_DATA]_FR	Data from front-right transmitter cannot be received.	
C1710	[NO_DATA]_RR	Data from rear-right transmitter cannot be received.	
C1711	[NO_DATA]_RL	Data from rear-left transmitter cannot be received.	
C1716	[PRESSDATA_ERR]_FL	Air pressure data from front-left transmitter is malfunctioning.	WT-32
C1717	[PRESSDATA_ERR]_FR	Air pressure data from front-right transmitter is malfunctioning.	
C1718	[PRESSDATA_ERR]_RR	Air pressure data from rear-right transmitter is malfunctioning.	
C1719	[PRESSDATA_ERR]_RL	Air pressure data from rear-left transmitter is malfunctioning.	
C1720	[CODE_ERROR]_FL	Function code data from front-left transmitter is malfunctioning.	WT-32
C1721	[CODE_ERROR]_FR	Function code data from front-right transmitter is malfunctioning.	
C1722	[CODE_ERROR]_RR	Function code data from rear-right transmitter is malfunctioning.	
C1723	[CODE_ERROR]_RL	Function code data from rear-left transmitter is malfunctioning.	
C1724	[BATT_VOLT_LOW]_FL	Battery voltage of front-left transmitter drops.	WT-33
C1725	[BATT_VOLT_LOW]_FR	Battery voltage of front-right transmitter drops.	
C1726	[BATT_VOLT_LOW]_RR	Battery voltage of rear-right transmitter drops.	
C1727	[BATT_VOLT_LOW]_RL	Battery voltage of rear-left transmitter drops.	
C1728	RECEIVER_ID_NO_REG	ID registration of receiver is not completed.	WT-33
C1729	VHCL_SPEED_SIG_ERR	Vehicle speed signal is error.	WT-34
C1750	[RECEIVER_ERR]_FL	Data from front-left receiver cannot be received.	WT-31
C1751	[RECEIVER_ERR]_FR	Data from front-right receiver cannot be received.	
C1752	[RECEIVER_ERR]_RR	Data from rear-right receiver cannot be received.	
C1753	[RECEIVER_ERR]_RL	Data from rear-left receiver cannot be received.	
U1000	CAN COMM CIRCUIT	When a control unit (except for low tire pressure) is not transmitting or receiving CAN communication signal 2 seconds or less.	WT-34

NOTE:

Before performing the self-diagnosis, be sure to register the ID, or else the actual malfunction location may be different from that displayed on CONSULT-II.

TROUBLE DIAGNOSES

NOTICE:

186 kPa (1.86 kg/cm² , 27 psi): Standard air pressure is for 230 kPa (2.3 kg/cm² , 33 psi) vehicles.

How to Erase Self-Diagnostic Results

1. Perform applicable inspection of malfunctioning item and then repair or replace.
2. Start engine, and touch "START (NISSAN BASED VHCL)" "AIR PRESSURE MONITOR" "SELF-DIAG RESULTS" "ERASE" in this order to erase the diagnostic memory.

CAUTION:

If memory cannot be erased, repeat step 1, 2.

3. Perform self-diagnosis again, and make sure that DTC memory is erased.

DATA MONITOR MODE

Operation Procedure

1. Perform "CONSULT-II Start Procedure". Refer to [GI-39, "CONSULT-II Start Procedure"](#).
2. Touch "DATA MONITOR".
3. Select from "SELECT MONITOR ITEM", screen of data monitor is displayed.

NOTE:

When malfunction is detected, CONSULT-II performs REAL-TIME DIAGNOSIS. Also, any malfunction detected while in this mode will be displayed in real time.

Display Item List

MONITOR	CONDITION	SPECIFICATION
VEHICLE SPEED SE	Drive vehicle.	Vehicle speed (km/h or MPH)
AIR PRESS FL AIR PRESS FR AIR PRESS RR AIR PRESS RL	<ul style="list-style-type: none"> ● Drive vehicle for a few minutes. or <ul style="list-style-type: none"> ● Ignition switch ON and activation tool is transmitting activation signals. 	Tire pressure (kPa or Psi)
ID REGST FL 1 ID REGST FR 1 ID REGST RR 1 ID REGST RL 1	Ignition switch ON	Registration ID: DONE No registration ID: YET
WARNING LAMP		Low tire pressure warning lamp on: ON Low tire pressure warning lamp off: OFF
BUZZER		Buzzer in combination meter on: ON Buzzer in combination meter off: OFF

NOTE:

Before performing the self-diagnosis, be sure to register the ID, or else the actual malfunction location may be different from that displayed on CONSULT-II.

ACTIVE TEST MODE

Operation Procedure

1. Perform "CONSULT-II Start Procedure". Refer to [GI-39, "CONSULT-II Start Procedure"](#).
2. "ACTIVE TEST" is displayed.

Display Item List

Test item	Content
BUZZER	This test is able to check to make sure that the buzzer sounds.
WARNING LAMP	This test is able to check to make sure that the warning lamp turns on.
HAZARD LAMP	This test is able to check to make sure that hazard lamp turns on.

NOTE:

Before performing the self-diagnosis, be sure to register the ID, or else the actual malfunction location may be different from that displayed on CONSULT-II.

TROUBLE DIAGNOSES

LOW TIRE PRESSURE WARNING CONTROL UNIT PART NUMBER

Operation Procedure

1. Perform "CONSULT-II Start Procedure". Refer to [GI-39, "CONSULT-II Start Procedure"](#) .
2. The part number described on low tire pressure warning control unit sticker is displayed.

Diagnosis Procedure with Warning Lamp Function (Without CONSULT-II)

NES000K6









DESCRIPTION

During driving, the low tire pressure warning system receives the signal transmitted from the transmitter installed in each wheel, and gives alarms when the tire pressure becomes low. The control unit (low tire pressure warning control unit) of this system has pressure judgement and trouble diagnosis functions.



FUNCTION

When the low tire pressure warning system detects low inflation pressure or another unusual symptom, the warning lamps in the combination meter comes on. To start the self-diagnostic results mode, ground terminal of the tire pressure warning check connector. The malfunction location is indicated by the warning lamp flashing and the buzzer sounds. Regarding location of tire pressure warning check connector, refer to [PG-63, "HARNESSES"](#) .

LOW TIRE PRESSURE WARNING LAMP DIAGNOSTIC CHART

Diagnosis Item	Symptom (Ignition switch ON)	Low tire pressure warning lamp	Cause	Action
Low tire pressure warning lamp	Warning light comes on immediately and turns off after 1 second.	 ON 1 sec > stays OFF SEIA0592E	All wheel transmitters are "activated" (working).	None (system OK)
	Warning light blinks on for 2 seconds, then turns off for 0.2 seconds-repeats.	 Blinks:  ON 2 sec > OFF 0.2 sec SEIA0593E	All wheel transmitters are not activated.	Activate all wheel tire pressure transmitters. Refer to WT-21, "Transmitter Wake Up Operation" .
	Warning light blinks 1 time.	 Blinks 1 time ON 0.3 sec > OFF 1.3 sec SEIA0594E	Tire pressure transmitter front LH is not activated.	Activate tire pressure transmitter front LH. Refer to WT-21, "Transmitter Wake Up Operation" .
	Warning light blinks 2 times.	  Blinks 2 times ON 0.3 sec > OFF 0.3 sec SEIA0595E	Tire pressure transmitter front RH is not activated.	Activate tire pressure transmitter front RH. Refer to WT-21, "Transmitter Wake Up Operation" .
	Warning light blinks 3 times.	   Blinks 3 times ON 0.3 sec > OFF 0.3 sec SEIA0596E	Tire pressure transmitter rear RH is not activated.	Activate tire pressure transmitter rear RH. Refer to WT-21, "Transmitter Wake Up Operation" .

TROUBLE DIAGNOSES

Diagnosis Item	Symptom (Ignition switch ON)	Low tire pressure warning lamp	Cause	Action
Low tire pressure warning lamp	Warning light blinks 4 times.	 Blinks 4 times ON 0.3 sec > OFF 0.3 sec <small>SEIA0597E</small>	Tire pressure transmitter rear LH is not activated.	Activate tire pressure transmitter rear LH. Refer to WT-21, "Transmitter Wake Up Operation" .
	Warning light comes on and does not turn off.	 Comes ON and stays ON <small>SEIA0598E</small>	Tire pressure is low.	Check tire pressure with CONSULT-II. Refer to WT-23, "DATA MONITOR MODE" .
			The fuse for combination meter from battery is pulled out.	Check the fuse for combination meter from battery. Install or replace (if needed).
			Low tire pressure warning control unit connector pulled out	Check low tire pressure warning control unit connector. Reconnect if needed.
			Low tire pressure or low tire pressure warning system malfunction.	<ul style="list-style-type: none"> ● Perform CONSULT-II Self-Diagnosis. Refer to WT-22, "SELF-DIAG RESULT MODE" . – Perform ID Registration if needed. Refer to WT-19, "ID Registration Procedure" .
Turn signal lamp	Turn signal lamp does not flash 2 times or buzzer does not sound after transmitter activation.	—	<ol style="list-style-type: none"> 1. Tool J-45295 [SST] 2. Ignition OFF during activation. 3. Tool J-45295 [SST] not positioned correctly. 4. Transmitters already activated. 	<ol style="list-style-type: none"> 1. Install new battery. 2. Make sure ignition is ON during activation. 3. Position tool correctly during activation. 4. None

NOTE:

If more than one wheel transmitter is NOT activated, the warning lamp blinking patterns for those wheels will combine. (Example: one blink/OFF/three blinks = Tire pressure transmitter rear LH and rear RH are not activated.)

A
B
C
D
WT
F
G
H
I
J
K
L
M

TROUBLE DIAGNOSES

How to Perform Trouble Diagnosis for Quick and Accurate Repair

NES000K7

INTRODUCTION

- Before troubleshooting, verify customer complaints.
- If a vehicle malfunction is difficult to reproduce, harnesses, harness connectors or terminals may be malfunctioning. Hold and shake these parts to make sure they are securely connected.
- When using a circuit tester to measure voltage or resistance of each circuit, be careful not to damage or deform connector terminals.

WORK FLOW

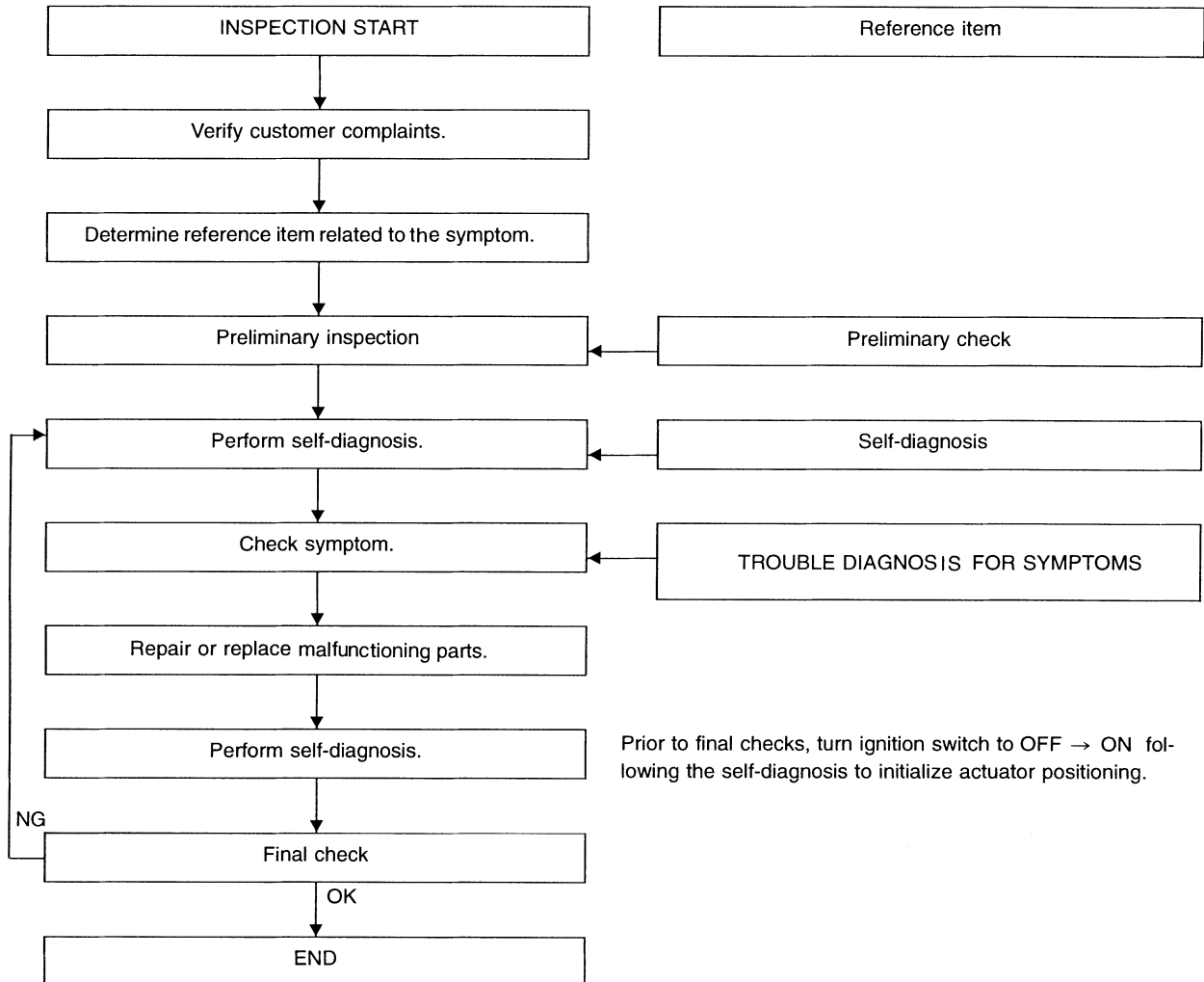

SEIA0100E

Preliminary check: [WT-27](#) Self-diagnosis: [WT-22](#) Trouble diagnosis for symptoms: [WT-35](#)

TROUBLE DIAGNOSES

Preliminary Check

NES000K8

BASIC INSPECTION

1. CHECK ALL TIRE PRESSURES

Check all tire pressures. Refer to [WT-41, "SERVICE DATA AND SPECIFICATIONS \(SDS\)"](#).

OK or NG

- OK >> GO TO 2.
- NG >> Adjust tire pressure to specified value.

2. CHECK LOW TIRE PRESSURE WARNING LAMP ACTIVATION

1. Check low tire pressure warning lamp activation.
2. Does low tire pressure warning lamp activate for 1 second when ignition switch is turned "ON".

Does warning lamp activate?

- YES >> GO TO 3.
- NO >> Check fuse and combination meter. Refer to [DI-5, "COMBINATION METERS"](#).

3. CHECK CONNECTOR

1. Disconnect low tire pressure warning control unit harness connectors M19.
2. Check terminals for damage or loose connection.

OK or NG

- OK >> GO TO 4.
- NG >> Repair or replace damaged parts.

4. CHECK ACTIVATION TOOL

Check activation tool battery.

OK or NG

- OK >> Perform self-diagnosis.
- NG >> Replace activation tool battery.

A

B

C

D

WT

F

G

H

I

J

K

L

M

TROUBLE DIAGNOSES

Trouble Diagnosis Chart SELF-DIAGNOSIS

NES000K9

Item			Reference
Self-diagnosis function		CONSULT-II	
DTC (warning lamp blinks)	Diagnosis item	Diagnosis item	
11	Front-left tire pressure drops to * kPa (* kg/cm ² , * psi) or less. (Notice)	FLAT_TIRE_FL	—
12	Front-right tire pressure drops to * kPa (* kg/cm ² , * psi) or less. (Notice)	FLAT_TIRE_FR	
13	Rear-right tire pressure drops to * kPa (* kg/cm ² , * psi) or less. (Notice)	FLAT_TIRE_RR	
14	Rear-left tire pressure drops to * kPa (* kg/cm ² , * psi) or less. (Notice)	FLAT_TIRE_RL	
21	Transmitter no data (front - left)	[NO_DATA]_FL	WT-30
22	Transmitter no data (front - right)	[NO_DATA]_FR	
23	Transmitter no data (rear - right)	[NO_DATA]_RR	
24	Transmitter no data (rear - left)	[NO_DATA]_RL	
25	Receiver data error (front - left)	[RECEIVER_ERR]_FL	WT-31
26	Receiver data error (front - right)	[RECEIVER_ERR]_FR	
27	Receiver data error (rear - right)	[RECEIVER_ERR]_RR	
28	Receiver data error (rear - left)	[RECEIVER_ERR]_RL	
35	Transmitter pressure data error (front - left)	[PRESSDATA_ERR]_FL	WT-32
36	Transmitter pressure data error (front - right)	[PRESSDATA_ERR]_FR	
37	Transmitter pressure data error (rear - right)	[PRESSDATA_ERR]_RR	
38	Transmitter pressure data error (rear - left)	[PRESSDATA_ERR]_RL	
41	Transmitter function code error (front - left)	[CODE_ERROR]_FL	WT-32
42	Transmitter function code error (front - right)	[CODE_ERROR]_FR	
43	Transmitter function code error (rear - right)	[CODE_ERROR]_RR	
44	Transmitter function code error (rear - left)	[CODE_ERROR]_RL	
45	Transmitter battery voltage low (front - left)	[BATT_VOLT_LOW]_FL	WT-33
46	Transmitter battery voltage low (front - right)	[BATT_VOLT_LOW]_FR	
47	Transmitter battery voltage low (rear - right)	[BATT_VOLT_LOW]_RR	
48	Transmitter battery voltage low (rear - left)	[BATT_VOLT_LOW]_RL	
51	Receiver ID no registration	RECEIVER_ID_NO_REG	WT-33
52	Vehicle speed signal	VHCL_SPED_SIG_ERR	WT-34
—	—	CAN COMM CIRCUIT	WT-34

NOTICE:

186 kPa (1.86 kg/cm², 27 psi): Standard air pressure is for 230 kPa (2.3 kg/cm², 33 psi) vehicles.

TROUBLE DIAGNOSES

DIAGNOSIS CHART BY SYMPTOM

Symptom	Reference
Warning lamp does not come on when ignition switch is turned on.	WT-35, "Inspection 1: Warning Lamp Does Not Come On When Ignition Switch Is Turned On"
Warning lamp stays on when ignition switch is turned on.	WT-36, "Inspection 2: Warning Lamp Stays On When Ignition Switch Is Turned On"
Warning lamp blinks when ignition switch is turned on	WT-37, "Inspection 3: Warning Lamp Blinks When Ignition Switch Is Turned On"
Turn signal lamp blinks when ignition switch is turned on	WT-37, "Inspection 4: Turn Signal Lamp Blinks When Ignition Switch Is Turned On"
ID registration can not be operated.	WT-38, "Inspection 5: ID Registration Can Not Be Completed"

A
B
C
D

WT

F
G
H
I
J
K
L
M

TROUBLE DIAGNOSIS FOR SELF-DIAGNOSTIC ITEMS

TROUBLE DIAGNOSIS FOR SELF-DIAGNOSTIC ITEMS

PFP:00000

Inspection 1: Transmitter no Data MALFUNCTION CODE NO. 21, 22, 23, 24

NES000KA

1. CHECK CONTROL UNIT

Drive for several minutes. Check all tire pressures with CONSULT-II "DATA MONITOR".

Are all tire pressures displayed 0 kPa?

- YES >> GO TO 2.
- NO >> GO TO 3.

2. CHECK TIRE PRESSURE RECEIVER CONNECTOR

1. Disconnect tire pressure receiver harness connector E74 (FR-LH), E75 (FR-RH), B116 (RR-RH), B115 (RR-LH).
2. Check terminals for damage or loose connection.
3. Reconnect harness connector.

OK or NG

- OK >> Replace low tire pressure warning control unit. Refer to [WT-40, "Low Tire Pressure Warning Control Unit"](#), then GO TO 3.
- NG >> Repair or replace tire pressure receiver harness connector.

3. ID REGISTRATION

Perform ID registration of all transmitters.

Are there any tires that ID can not be registered to?

- YES >> Replace transmitter of the tire, then GO TO 5.
- NO >> GO TO 4.

4. VEHICLE DRIVING

Drive at a speed of 40 km/h (25 MPH) or more for several minutes without stopping.

Check all tire pressures with CONSULT-II "DATA MONITOR" within 15 minutes after vehicle speed becomes 17 km/h (11 MPH).

Does "DATA MONITOR" display tire pressure as normal without any warning lamp?

- YES >> INSPECTION END
- NO >> GO TO 5.

5. ID REGISTRATION AND VEHICLE DRIVING

1. Perform ID registration of all transmitters.
2. Drive at a speed of 40 km/h (25 MPH) or more for 3 minutes, and then drive the vehicle at any speed for 10 minutes. Then check all tire pressures with CONSULT-II "DATA MONITOR" within 5 minutes.

Does "DATA MONITOR" display tire pressure as normal without any warning lamp?

- YES >> INSPECTION END
- NO >> GO TO the inspection applicable to DTC.

TROUBLE DIAGNOSIS FOR SELF-DIAGNOSTIC ITEMS

Inspection 2: Receiver Data Error MALFUNCTION CODE NO. 25, 26, 27, 28

NES000KB

1. CHECK LOW TIRE PRESSURE WARNING CONTROL UNIT AND RECEIVER CONNECTOR

1. Turn ignition switch OFF, disconnect low tire pressure warning control unit harness connector and receiver harness connector, and check terminal for deformation, disconnection, looseness, and so on. If there is a malfunction, repair or replace the terminal.
2. Reconnect connector securely, and perform self-diagnosis.

Does "SELF-DIAG RESULTS" display as normal without any warning lamp?

- YES >> Connector terminal connection is loose, damaged, open, or shorted.
NO >> GO TO 2.

2. CHECK TIRE PRESSURE RECEIVER POWER SUPPLY AND GROUND CIRCUIT

1. Turn ignition switch OFF, and disconnect tire pressure receiver harness connector E74, E75, B115, B116.
2. Check continuity between tire pressure receiver harness connector E74, E75, B115, B116 and ground.

Terminal 4 – Ground : Continuity exist.

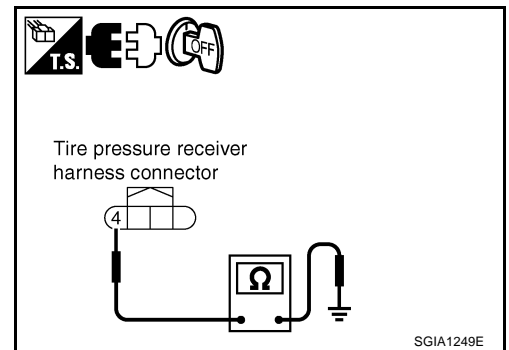

3. Turn ignition switch ON, and then check voltage between tire pressure receiver harness connector E74, E75, B115, B116 and ground.

1 – Ground : Battery voltage (Approx.12 V)

OK or NG

- OK >> GO TO 3.
NG >> GO TO 4.

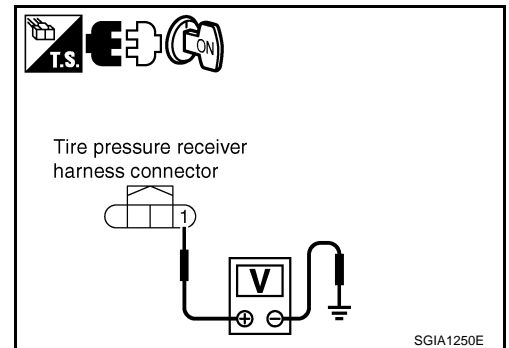

3. CHANGE THE TIRE PRESSURE RECEIVER POSITION (EXAMPLE OF FRONT LH SIDE)

1. Replace right from left for front and rear receivers.
2. Perform self-diagnosis.

Is the initial indication of self-diagnosis displayed?

- YES >> GO TO 4
NO >> Replace tire pressure receiver front RH when indicating RH tire pressure receiver malfunction.

TROUBLE DIAGNOSIS FOR SELF-DIAGNOSTIC ITEMS

4. CHECK RECEIVER HARNESS (EXAMPLE OF FRONT LH SIDE)

1. Turn ignition switch OFF, disconnect low tire pressure warning control unit harness connector M19 and receiver harness connector E74.
2. Check continuity between low tire pressure warning control unit harness connector M19 and receiver harness connector E74.

Terminal 27 – 2 : Continuity exist.

Terminal 11 – 3 : Continuity exist.

OK or NG

- OK >> Replace low tire pressure warning control unit.
NO >> Harness between Low tire warning control unit and Receiver until open or shorted. Repair or replace harness.

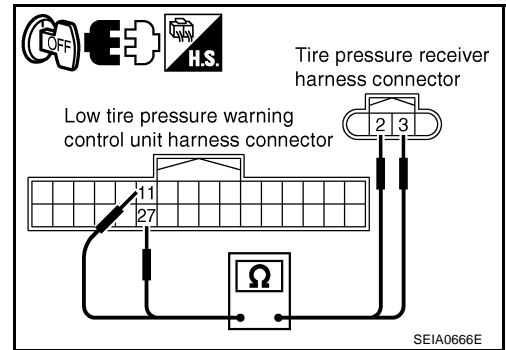

Inspection 3: Transmitter Pressure Data Error MALFUNCTION CODE NO. 35, 36, 37, 38

NES000KC

1. CHECK ALL TIRE PRESSURES

Check all tire pressures. Refer to [WT-41, "SERVICE DATA AND SPECIFICATIONS \(SDS\)"](#).

Are there any tires whose pressure is "64 psi" or more?

- YES >> Adjust tire pressure to specified value.
NO >> GO TO 2.

2. VEHICLE DRIVING

1. Perform ID registration of all transmitters.
2. Drive at a speed of 40 km/h (25 MPH) or more for several minutes without stopping. Check all tire pressures with CONSULT-II "DATA MONITOR" within 15 minutes after vehicle speed becomes 17 km/h (11 MPH).

>> Replace tire pressure transmitter with new one if "DATA MONITOR" display 64 psi or more. Then GO TO 3.

3. ID REGISTRATION AND VEHICLE DRIVING

1. Perform ID registration of all tire pressure transmitters.
2. Drive at a speed of 40 km/h (25 MPH) or more for 3 minutes, and then drive the vehicle at any speed for 10 minutes. Then check all tire pressures with CONSULT-II "DATA MONITOR" within 5 minutes.

Does "DATA MONITOR" display tire pressure as normal without any warning lamp?

- YES >> INSPECTION END
NO >> GO TO the inspection applicable to DTC.

Inspection 4: Transmitter Function Code Error MALFUNCTION CODE NO. 41, 42, 43, 44

NES000KD

1. ID REGISTRATION (CORRECTION OF TRANSMITTER LOCATION)

1. Perform ID registration of all transmitters.
2. Drive at a speed of 40 km/h (25 MPH) or more for 3 minutes, and then drive the vehicle at any speed for 10 minutes.

>> GO TO 2.

TROUBLE DIAGNOSIS FOR SELF-DIAGNOSTIC ITEMS

2. REPLACE TIRE PRESSURE TRANSMITTER

1. Check low tire pressure warning condition again, and replace malfunctioning tire pressure transmitter.
2. Perform ID registration of all transmitter.

Can ID registration of all tire pressure transmitters be completed?

YES >> GO TO 3.

NO >> GO TO the inspection 1. Refer to [WT-30, "Inspection 1: Transmitter no Data"](#) .

3. VEHICLE DRIVING

Drive at a speed of 40 km/h (25 MPH) or more for 3 minutes, and then drive the vehicle at any speed for 10 minutes. Then check all tire pressures with CONSULT-II "DATA MONITOR" within 5 minutes.

Does "DATA MONITOR" display tire pressure as normal without any warning lamp?

YES >> INSPECTION END

NO >> Replace malfunctioning transmitter, and perform "Step 3" again.

Inspection 5: Transmitter Battery Voltage Low MALFUNCTION CODE NO. 45, 46, 47, 48

NES000KE

1. ID REGISTRATION (CORRECTION OF TRANSMITTER LOCATION)

1. Perform ID registration of all transmitters.
2. Drive at a speed of 40 km/h (25 MPH) or more for 3 minutes, and then drive the vehicle at any speed for 10 minutes.

>> GO TO 2.

2. REPLACE TIRE PRESSURE TRANSMITTER

1. Check low tire pressure warning lamp condition again, and replace malfunctioning tire pressure transmitter.
2. Perform ID registration of all tire pressure transmitter.

Can ID registration of all tire pressure transmitters be completed?

YES >> GO TO 3.

NO >> GO TO the inspection 1. Refer to [WT-30, "Inspection 1: Transmitter no Data"](#) .

3. VEHICLE DRIVING

Drive at a speed of 40 km/h (25 MPH) or more for 3 minutes, and then drive the vehicle at any speed for 10 minutes. Then check all tire pressures with CONSULT-II "DATA MONITOR" within 5 minutes.

Does "DATA MONITOR" display tire pressure as normal without any warning lamp?

YES >> INSPECTION END

NO >> Replace malfunctioning transmitter, and perform "Step 3" again.

Inspection 6: Receiver ID No Registration MALFUNCTION CODE NO. 51

NES000KF

1. ID REGISTRATION

1. Perform ID registration of all tire pressure transmitters. Refer to [WT-19, "ID Registration Procedure"](#) .
2. Drive at a speed of 40 km/h (25 MPH) or more for 3 minutes, and then drive the vehicle at any speed for 10 minutes.

>> GO TO 2.

TROUBLE DIAGNOSIS FOR SELF-DIAGNOSTIC ITEMS

2. REPLACE TIRE PRESSURE TRANSMITTER

1. Check low tire pressure warning condition again, and replace malfunctioning tire pressure transmitter.
2. Perform ID registration of all transmitter.

Can ID registration of all tire pressure transmitters be completed?

YES >> GO TO 3.

NO >> GO TO the inspection 1. Refer to [WT-30, "Inspection 1: Transmitter no Data"](#) .

3. VEHICLE DRIVING

Drive at a speed of 40 km/h (25 MPH) or more for 3 minutes, and then drive the vehicle at any speed for 10 minutes. Then check all tire pressures with CONSULT-II "DATA MONITOR" within 5 minutes.

Does "DATA MONITOR" display tire pressure as normal without any warning lamp?

YES >> INSPECTION END

NO >> Replace malfunctioning transmitter, and perform "Step 3" again.

Inspection 7: Vehicle Speed Signal MALFUNCTION CODE NO. 52

NES000KG

1. CHECK SELF-DIAGNOSIS RESULTS

1. Turn ignition switch OFF.
2. Connect CONSULT-II and CONSULT-II CONVERTER to data link connector.
3. Turn ignition switch ON.
4. Touch "START (NISSAN BASED VHCL)" "AIR PRESSURE MONITOR".
 - If "AIR PRESSURE MONITOR" is not displayed, print the "SELECT SYSTEM" screen. Then refer to [LAN-7, "Precautions When Using CONSULT-II"](#) .

NOTE:

Just after starting engine, or turning ignition switch ON, it may not be displayed even if "START (NISSAN BASED VHCL)" is touched. In this case, reconnect CONSULT-II and CONSULT-II CONVERTER.

5. Touch "SELF-DIAG RESULTS" on "SELECT DIAG MODE" screen.
6. Check display contents in self-diagnostic results.

Is "CAN COMM CIRCUIT" displayed in the self-diagnosis display items?

YES >> Malfunction in CAN communication system. GO TO [LAN-7, "Precautions When Using CONSULT-II"](#) .

NO >> No malfunction. Check combination meter refer to [DI-18, "Trouble Diagnosis"](#) .

Inspection 8: CAN Communication System Malfunction

NES000KS

1. CHECK LOW TIRE PRESSURE WARNING CONTROL UNIT CONNECTOR

1. Turn ignition switch OFF, disconnect low tire pressure warning control unit harness connector, and check terminal for deformation, disconnection, looseness, etc.
2. Reconnect harness connector securely, and perform CONSULT-II self-diagnosis.

Self-diagnostic results

CAN COMM CIRCUIT [U1000]

Is above displayed on self-diagnosis display?

YES >> If "CAN COMM CIRCUIT [U1000]" is displayed, print out self-diagnosis. And then, go to [LAN-7, "Precautions When Using CONSULT-II"](#) .

NO >> Connector terminal connection is loose, damaged, open, or shorted. Repair or replace the terminal.

TROUBLE DIAGNOSIS FOR SYMPTOMS

TROUBLE DIAGNOSIS FOR SYMPTOMS

PFP:00007

Inspection 1: Warning Lamp Does Not Come On When Ignition Switch Is Turned On

NES000KH

1. CHECK SELF-DIAGNOSIS RESULTS

1. Turn ignition switch OFF.
2. Connect CONSULT-II and CONSULT-II CONVERTER to data link connector.
3. Turn ignition switch ON.
4. Touch "START (NISSAN BASED VHCL)" "AIR PRESSURE MONITOR" "SELF-DIAG RESULTS".
 - If AIR PRESSURE MONITOR is not displayed, print the "SELECT SYSTEM" screen. Then refer to [LAN-7, "Precautions When Using CONSULT-II"](#).

NOTE:

Just after starting engine, or turning ignition switch ON, it may not be displayed even if "START (NISSAN BASED VHCL)" is touched. In this case, reconnect CONSULT-II and CONSULT-II CONVERTER.

5. Check display contents in self-diagnostic results.

Is "CAN COMM CIRCUIT" displayed in the self-diagnosis display items?

- YES >> Malfunction in CAN communication system. GO TO [LAN-7, "Precautions When Using CONSULT-II"](#).
- NO >> GO TO 2.

2. CHECK COMBINATION METER

Check combination meter function.

OK or NG

- OK >> GO TO 3.
- NG >> Check combination meter. Refer to [DI-18, "Trouble Diagnosis"](#).

3. CHECK LOW TIRE PRESSURE WARNING LAMP

Disconnect low tire pressure warning control unit harness connector M19.

Does the warning lamp activate?

- YES >> Replace low tire pressure warning control unit. Refer to [WT-40, "Low Tire Pressure Warning Control Unit"](#).
- NO >> Check combination meter and repair or replace.

TROUBLE DIAGNOSIS FOR SYMPTOMS

Inspection 2: Warning Lamp Stays On When Ignition Switch Is Turned On

NES000K1

1. CHECK CONNECTOR

1. Disconnect low tire pressure harness connectors M19.
2. Check terminals for damage or loose connections.

OK or NG

- OK >> GO TO 2.
NG >> Repair or replace damaged parts.

2. CHECK POWER SUPPLY CIRCUIT (IGN)

1. Turn ignition switch ON.
2. Measure voltage between low tire pressure warning control unit harness connector M19 and ground.

Terminal		Voltage
(+)	(-)	
2	Ground	12 V

OK or NG

- OK >> GO TO 3.
NG >> Check low tire pressure warning control unit power supply circuit for open or short.

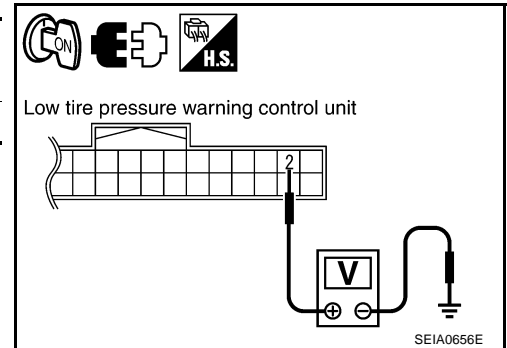

3. CHECK GROUND CIRCUIT

1. Turn ignition switch OFF.
2. Check continuity between low tire pressure warning control unit harness connector M19 and ground.

Terminal		Continuity
(+)	(-)	
17	Ground	Should exist.

OK or NG

- OK >> Replace low tire pressure warning control unit. Refer to [WT-40, "Low Tire Pressure Warning Control Unit"](#) .
NG >> Repair or replace low tire pressure warning control unit ground circuit.

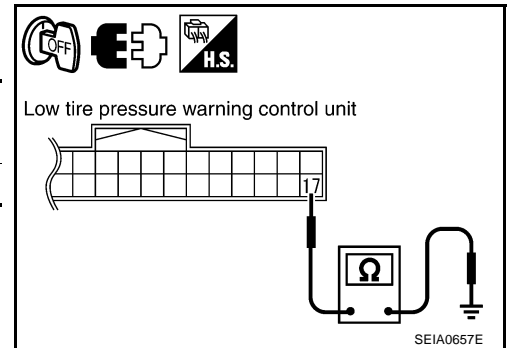

TROUBLE DIAGNOSIS FOR SYMPTOMS

Inspection 3: Warning Lamp Blinks When Ignition Switch Is Turned On

NES000KJ

NOTE:

If warning lamp blinks below, the system is normal.

Blink Mode A

- This mode shows transmitter status is in OFF-mode. Perform transmitter wake up operation. Refer to [WT-21, "Transmitter Wake Up Operation"](#).

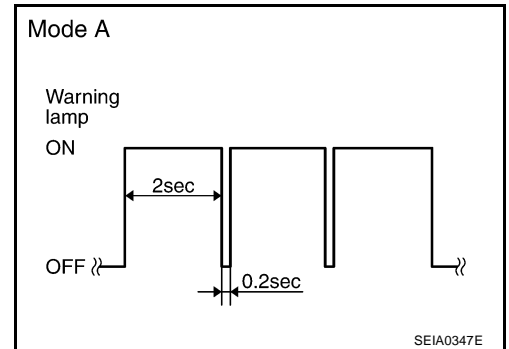

1. CHECK CONNECTOR

- Disconnect low tire pressure warning control unit harness connector M19.
- Check terminals for damage or loose connections.

OK or NG

- OK >> GO TO 2.
- NG >> Repair or replace damaged parts.

2. CHECK TIRE PRESSURE WARNING CHECK SWITCH CIRCUIT

Check continuity between low tire pressure warning control unit harness connector M19 and ground.

Terminal		Continuity
(+)	(-)	
5	Ground	No

OK or NG

- OK >> Replace low tire pressure warning control unit. Refer to [WT-40, "Low Tire Pressure Warning Control Unit"](#).
- NG >> Repair or replace harness connector.

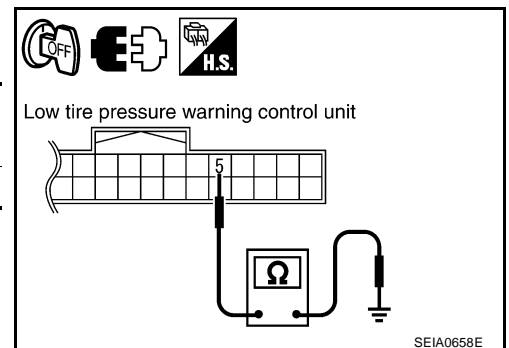

Inspection 4: Turn Signal Lamp Blinks When Ignition Switch Is Turned On

NES000KK

1. CHECK TIRE PRESSURE WARNING CHECK SWITCH CIRCUIT

Check continuity between low tire pressure warning control unit harness connector M19 and ground.

Terminal		Continuity
(+)	(-)	
5	Ground	No

OK or NG

- OK >> Check turn signal lamp operation. Refer to [LT-211, "System Description"](#).
- NG >> Repair or replace harness connector.

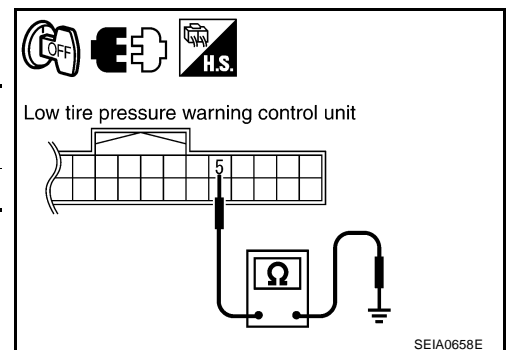

TROUBLE DIAGNOSIS FOR SYMPTOMS

Inspection 5: ID Registration Can Not Be Completed

NES000KL

1. ID REGISTRATION (ALL)

Perform ID registration of all transmitter.

Can ID registration of all transmitters be completed?

YES >> INSPECTION END

NO >> GO TO [WT-30, "TROUBLE DIAGNOSIS FOR SELF-DIAGNOSTIC ITEMS"](#) .

REMOVAL AND INSTALLATION

REMOVAL AND INSTALLATION

PFP:00000

Transmitter REMOVAL

NES000KM

1. Deflate tire. Unscrew transmitter retaining nut and allow transmitter to fall into tire.
2. Gently bounce tire so that transmitter falls to bottom of tire. Place on tire changing machine and break both tire beads ensuring that the transmitter remains at the bottom of the tire.

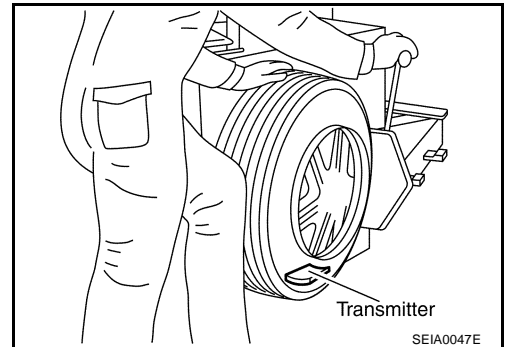

3. Turn tire so that valve hole is at bottom and bounce so that transmitter is near valve hole. Carefully lift tire onto turntable and position valve hole (and transmitter) 270 degree from mounting/dismounting head.
4. Lubricate tire well and remove first side of the tire. Reach inside the tire and remove the transmitter.

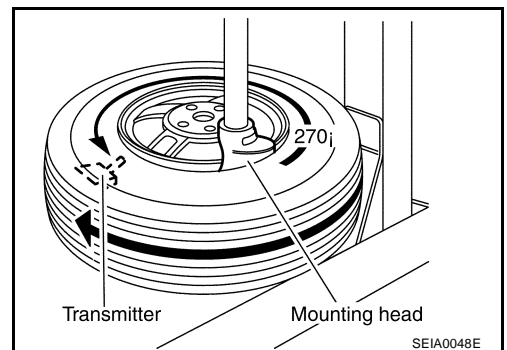

INSTALLATION

1. Put first side of tire onto rim.

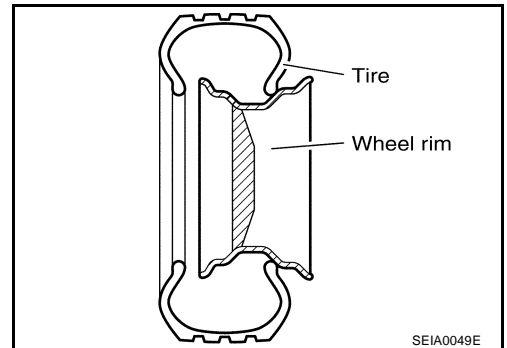

2. Mount transmitter on rim and tighten nut.

CAUTION:

Speed for tightening nut should be less than 40 rpm.

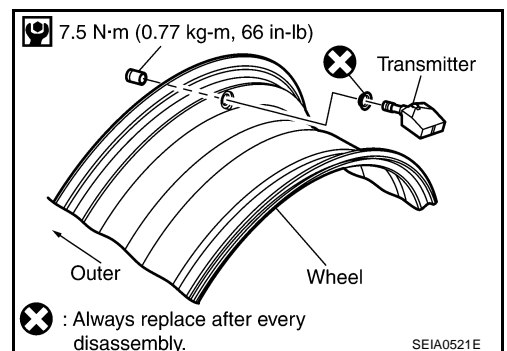

A
B
C
D
WT
F
G
H
I
J
K
L
M

REMOVAL AND INSTALLATION

- Place wheel on turntable of tire machine. Ensure that transmitter is 270 degree from mounting head when second side of tire is fitted.

NOTE:

Do not touch transmitter at mounting head.

- Lubricate tire well and fit second side of tire as normal. Ensure that tire does not rotate relative to rim.
- Inflate tire and fit to appropriate wheel position.

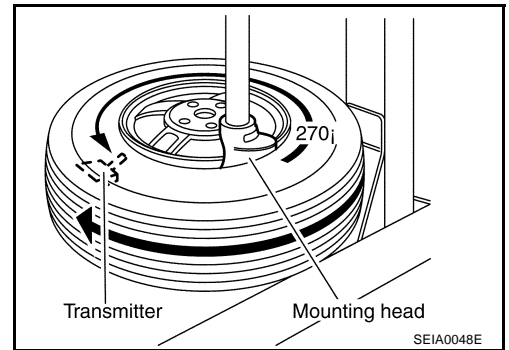

Low Tire Pressure Warning Control Unit REMOVAL

NES000KN

- Remove instrument driver lower panel. Refer to [IP-10, "INSTRUMENT PANEL ASSEMBLY"](#).
- Remove fixing bolt (1), and then remove low tire pressure warning control unit (2) from vehicle.

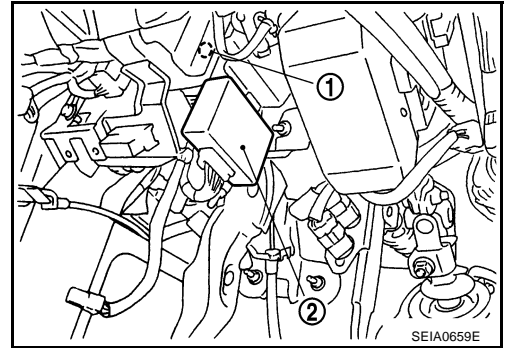

INSTALLATION

Installation is the reverse order of removal.

Receiver REMOVAL

NES000KO

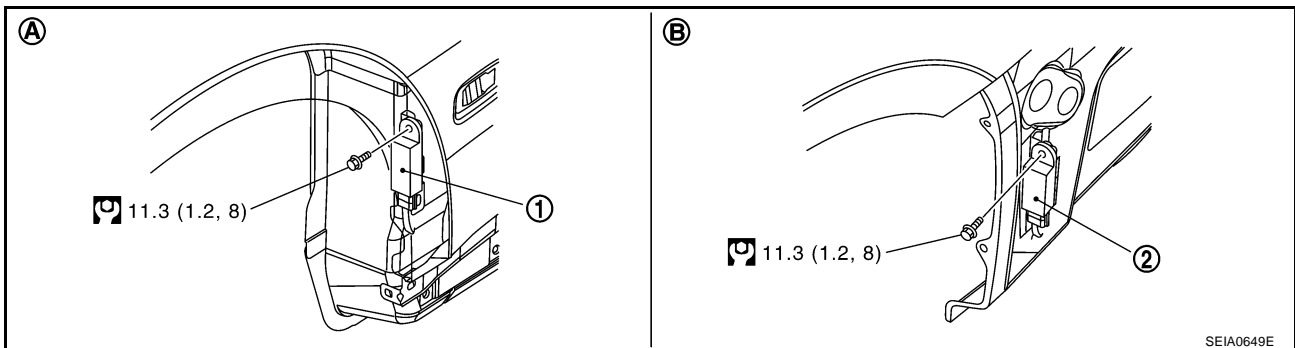

1. Tire pressure receiver front

2. Tire pressure receiver rear

A. Front wheel house

B. Rear wheel house

Refer to [GI-11, "Components"](#), for the symbols in the figure.

- Remove tire from vehicle with a power tool.
- Remove fender protector from vehicle. Refer to [EI-20, "FENDER PROTECTOR"](#).
- Remove fixing bolt, then remove tire pressure receiver from vehicle.

INSTALLATION

Installation is the reverse order of removal. For tightening torque, refer to [WT-40, "REMOVAL"](#).

SERVICE DATA AND SPECIFICATIONS (SDS)

SERVICE DATA AND SPECIFICATIONS (SDS)

PPF:00030

Road Wheel

NES000KP

Standard item		Allowable value	
		Aluminum	Steel (for emergency use)
Maximum radial runout limit	Lateral deflection	Less than 0.3 mm (0.012 in)	Less than 1.5 mm (0.059 in)
	Radial deflection	Less than 0.3 mm (0.012 in)	Less than 1.5 mm (0.059 in)
Maximum allowable unbalance	Dynamic (At rim flange)	Less than 7 g (0.25 oz) (one side)	
	Static (At rim flange)	Less than 14 g (0.49 oz)	

Tire

NES000KQ

Unit: kPa (kg/cm² , psi)

Tire size	Air pressure	
	Front	Rear
245/40R19 94W	230 (2.3, 33)	230 (2.3, 33)
P245/45R18 96V	230 (2.3, 33)	230 (2.3, 33)
T145/80D17 107M	420 (4.2, 60)	420 (4.2, 60)

A
B
C
D
WT
F
G
H
I
J
K
L
M

SERVICE DATA AND SPECIFICATIONS (SDS)
