

SECTION **PG**

**POWER SUPPLY, GROUND & CIRCUIT ELEMENTS**

**CONTENTS**

<b>POWER SUPPLY ROUTING CIRCUIT</b> .....	<b>3</b>	System Description .....	32
Schematic .....	3	<b>PUSH-BUTTON IGNITION SWITCH OPERATING PROCEDURE</b> .....	32
Wiring Diagram — POWER — .....	5	Wiring Diagram — PDU — .....	34
BATTERY POWER SUPPLY — IGNITION SW. IN ANY POSITION .....	5	Terminals and Reference Value for Intelligent Key Unit .....	36
ACCESSORY POWER SUPPLY — IGNITION SW. IN “ACC” OR “ON” .....	11	Terminals and Reference Value for PDU .....	37
IGNITION POWER SUPPLY — IGNITION SW. IN “ON” AND/OR “START” .....	12	Work Flow .....	37
Fuse .....	17	Trouble Diagnosis Symptom Chart .....	38
Fusible Link .....	17	Check CAN Communication System .....	38
Circuit Breaker .....	17	Check PDU Power Supply and Ground Circuit .....	39
<b>IPDM E/R (INTELLIGENT POWER DISTRIBUTION MODULE ENGINE ROOM)</b> .....	<b>18</b>	Check Push-Button Ignition Switch (Ignition Switch) System .....	39
System Description .....	18	Check Push-Button Ignition Switch (Indicator Circuit) System .....	41
SYSTEMS CONTROLLED BY IPDM E/R .....	18	PDU Communication Circuit System 1 .....	42
CAN COMMUNICATION LINE CONTROL .....	18	PDU Communication Circuit System 2 .....	43
IPDM E/R STATUS CONTROL .....	19	Removal and Installation of PDU .....	44
CAN Communication System Description .....	19	REMOVAL .....	44
CAN Communication Unit .....	19	INSTALLATION .....	44
Function of Detecting Ignition Relay Malfunction ...	19	<b>GROUND</b> .....	<b>45</b>
CONSULT-II Function (IPDM E/R) .....	20	Ground Distribution .....	45
CONSULT-II BASIC OPERATION .....	20	MAIN HARNESS .....	45
SELF-DIAG RESULTS .....	20	ENGINE ROOM HARNESS .....	50
DATA MONITOR .....	21	ENGINE CONTROL HARNESS/VQ ENGINE MODELS .....	54
CAN DIAG SUPPORT MNTR .....	22	ENGINE CONTROL HARNESS/VK ENGINE MODELS .....	55
ACTIVE TEST .....	22	BODY HARNESS .....	56
Auto Active Test .....	23	BODY NO. 2 HARNESS .....	60
DESCRIPTION .....	23	<b>HARNESS</b> .....	<b>62</b>
OPERATION PROCEDURE .....	23	Harness Layout .....	62
INSPECTION IN AUTO ACTIVE TEST MODE ...	24	HOW TO READ HARNESS LAYOUT .....	62
Schematic .....	27	OUTLINE .....	63
IPDM E/R Terminal Arrangement .....	28	MAIN HARNESS .....	64
Check IPDM E/R Power Supply and Ground Circuit. ...	29	NAVIGATION SUB-HARNESS & A/C HARNESS..	69
Inspection with CONSULT-II (Self-Diagnosis) .....	30	ENGINE ROOM HARNESS .....	70
Removal and Installation of IPDM E/R .....	31	ENGINE CONTROL HARNESS (VQ ENGINE)...	77
REMOVAL .....	31	ENGINE CONTROL HARNESS (VK ENGINE)...	80
INSTALLATION .....	31	BODY HARNESS .....	83
<b>PDU (POWER DISTRIBUTION UNIT)</b> .....	<b>32</b>		
Component Parts and Harness Connector Location. ...	32		

BODY NO. 2 HARNESS .....	87	TYPE) .....	105
TAIL HARNESS .....	91	HARNESS CONNECTOR (LEVER LOCKING	
ROOM LAMP HARNESS .....	92	TYPE) .....	106
FRONT DOOR HARNESS .....	93	<b>ELECTRICAL UNITS</b> .....	<b>107</b>
REAR DOOR HARNESS .....	94	Terminal Arrangement .....	107
Wiring Diagram Codes (Cell Codes) .....	95	<b>SMJ (SUPER MULTIPLE JUNCTION)</b> .....	<b>109</b>
<b>ELECTRICAL UNITS LOCATION</b> .....	<b>98</b>	Terminal Arrangement .....	109
Electrical Units Location .....	98	<b>STANDARDIZED RELAY</b> .....	<b>112</b>
ENGINE COMPARTMENT .....	98	Description .....	112
PASSENGER COMPARTMENT .....	100	NORMAL OPEN, NORMAL CLOSED AND	
LUGGAGE COMPARTMENT .....	103	MIXED TYPE RELAYS .....	112
<b>HARNESS CONNECTOR</b> .....	<b>104</b>	TYPE OF STANDARDIZED RELAYS .....	112
Description .....	104	<b>FUSE BLOCK - JUNCTION BOX (J/B)</b> .....	<b>114</b>
HARNESS CONNECTOR (TAB-LOCKING		Terminal Arrangement .....	114
TYPE) .....	104	<b>FUSE, FUSIBLE LINK AND RELAY BOX</b> .....	<b>115</b>
HARNESS CONNECTOR (SLIDE-LOCKING		Terminal Arrangement .....	115



# POWER SUPPLY ROUTING CIRCUIT

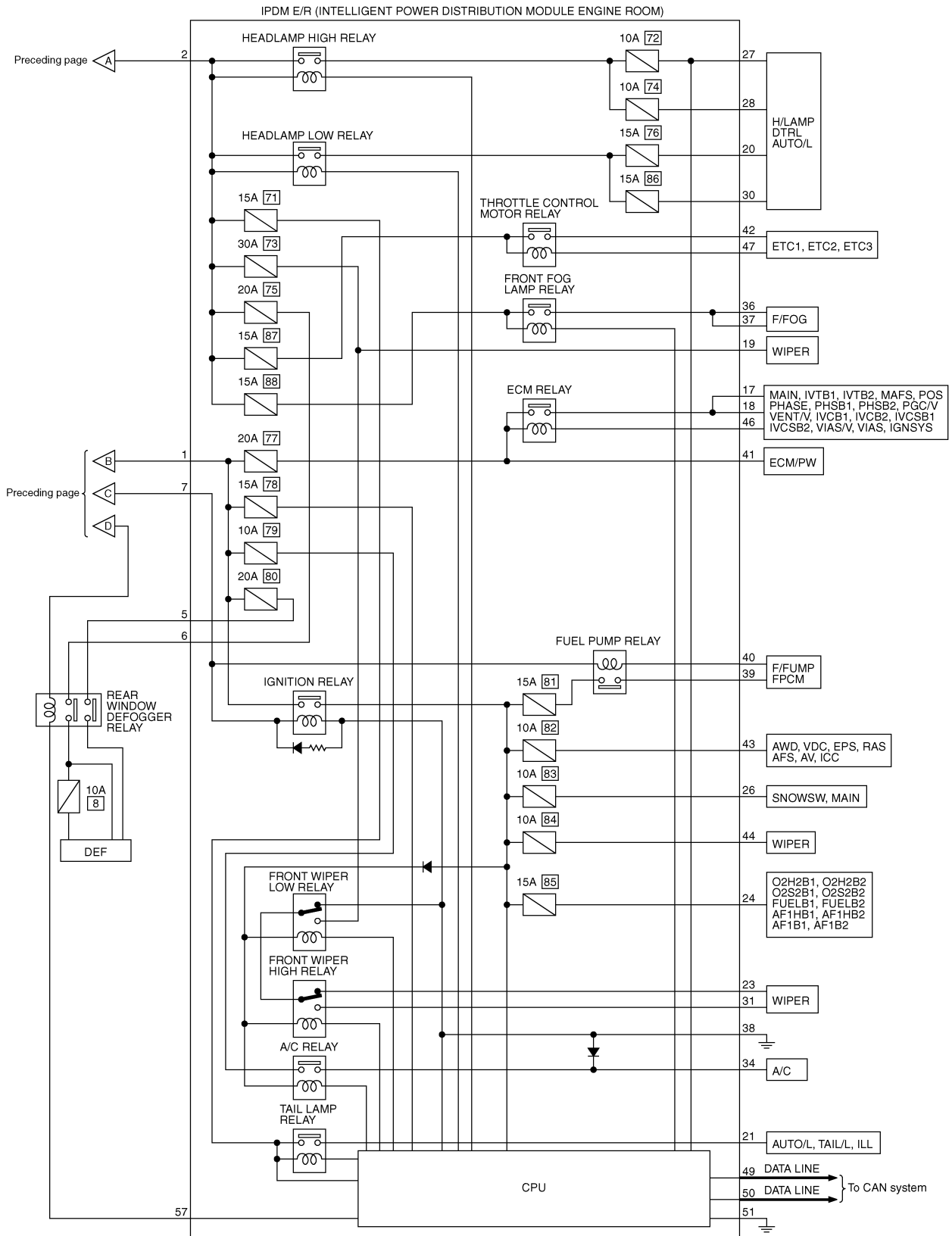

TKWT3565E

# POWER SUPPLY ROUTING CIRCUIT

NKS004DY

## Wiring Diagram — POWER — BATTERY POWER SUPPLY — IGNITION SW. IN ANY POSITION

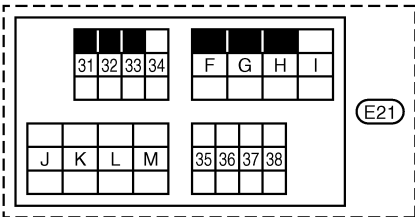
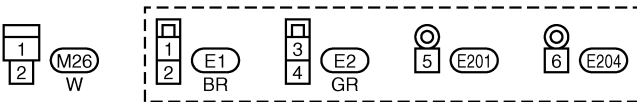
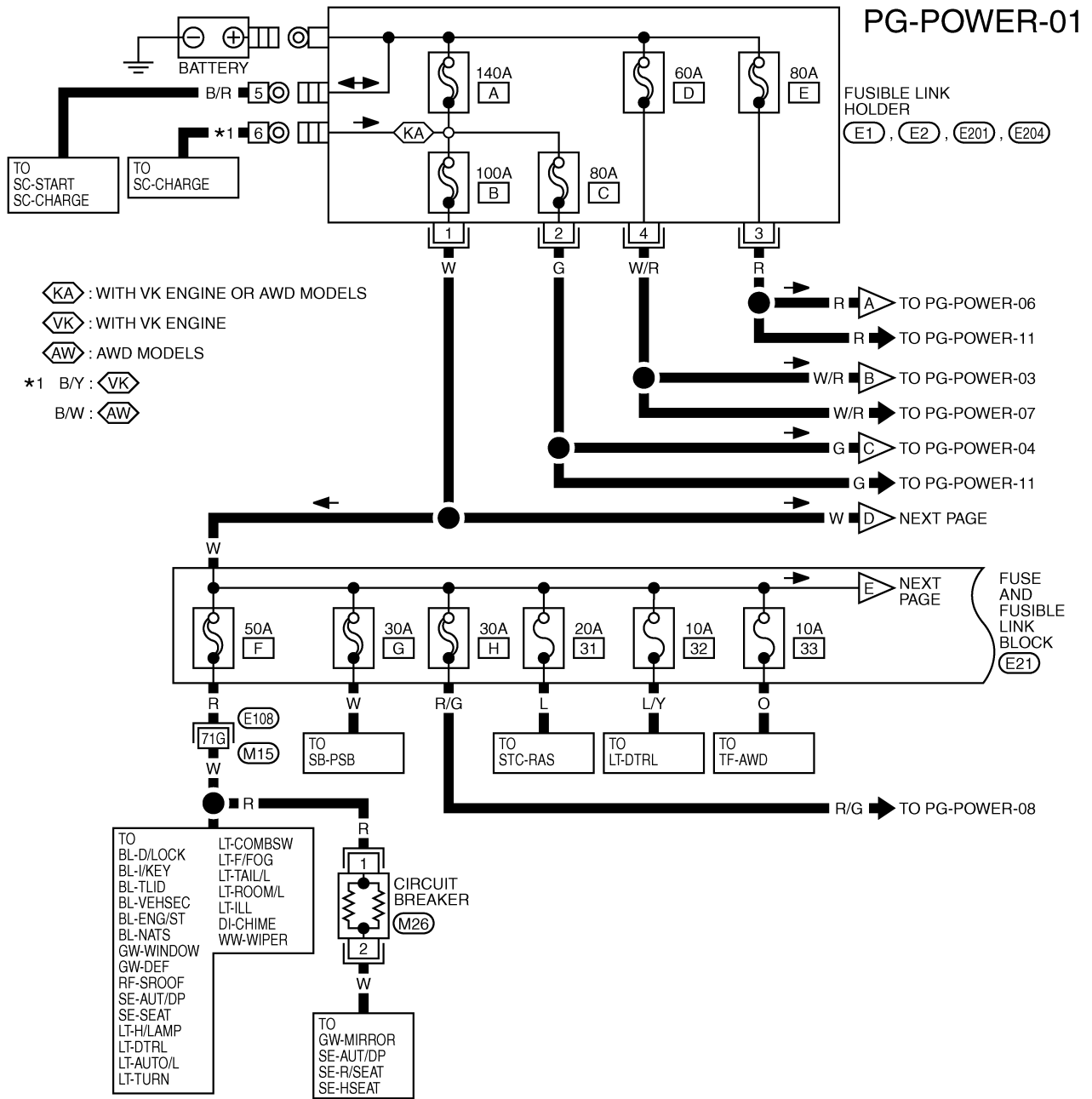

REFER TO THE FOLLOWING.  
 (E108) -SUPER MULTIPLE JUNCTION (SMJ)

A  
B  
C  
D  
E  
F  
G  
H  
I  
J  
PG  
L  
M

# POWER SUPPLY ROUTING CIRCUIT

PG-POWER-02

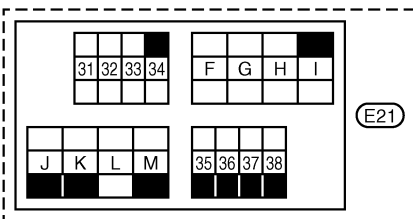
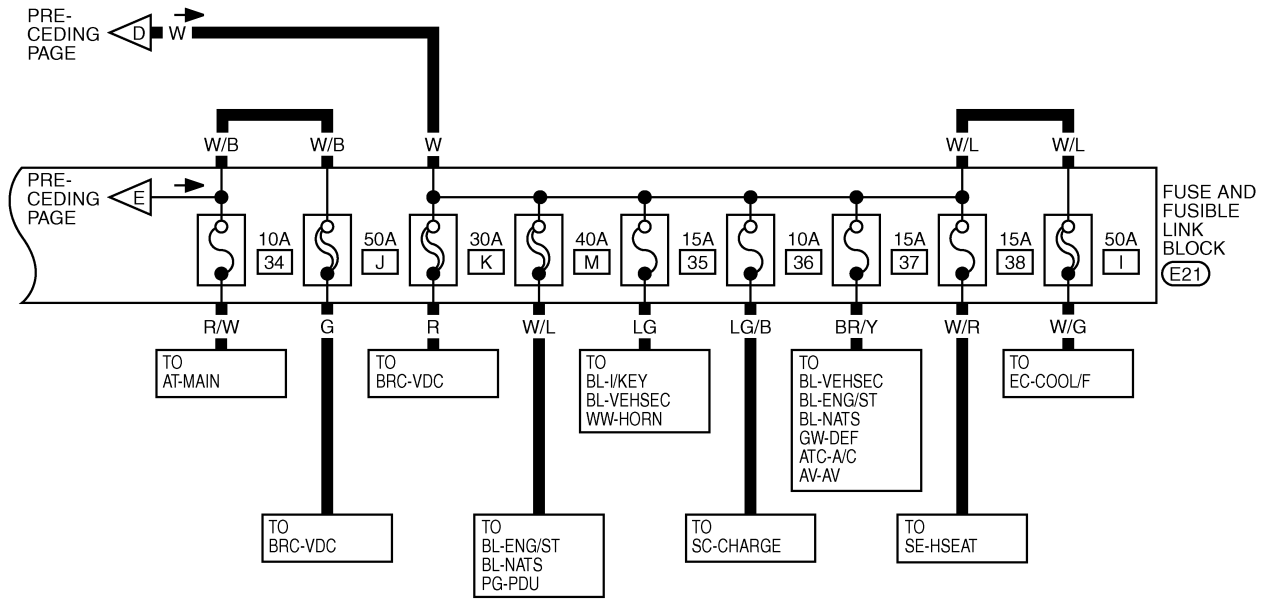

TKWT3567E

# POWER SUPPLY ROUTING CIRCUIT

PG-POWER-03

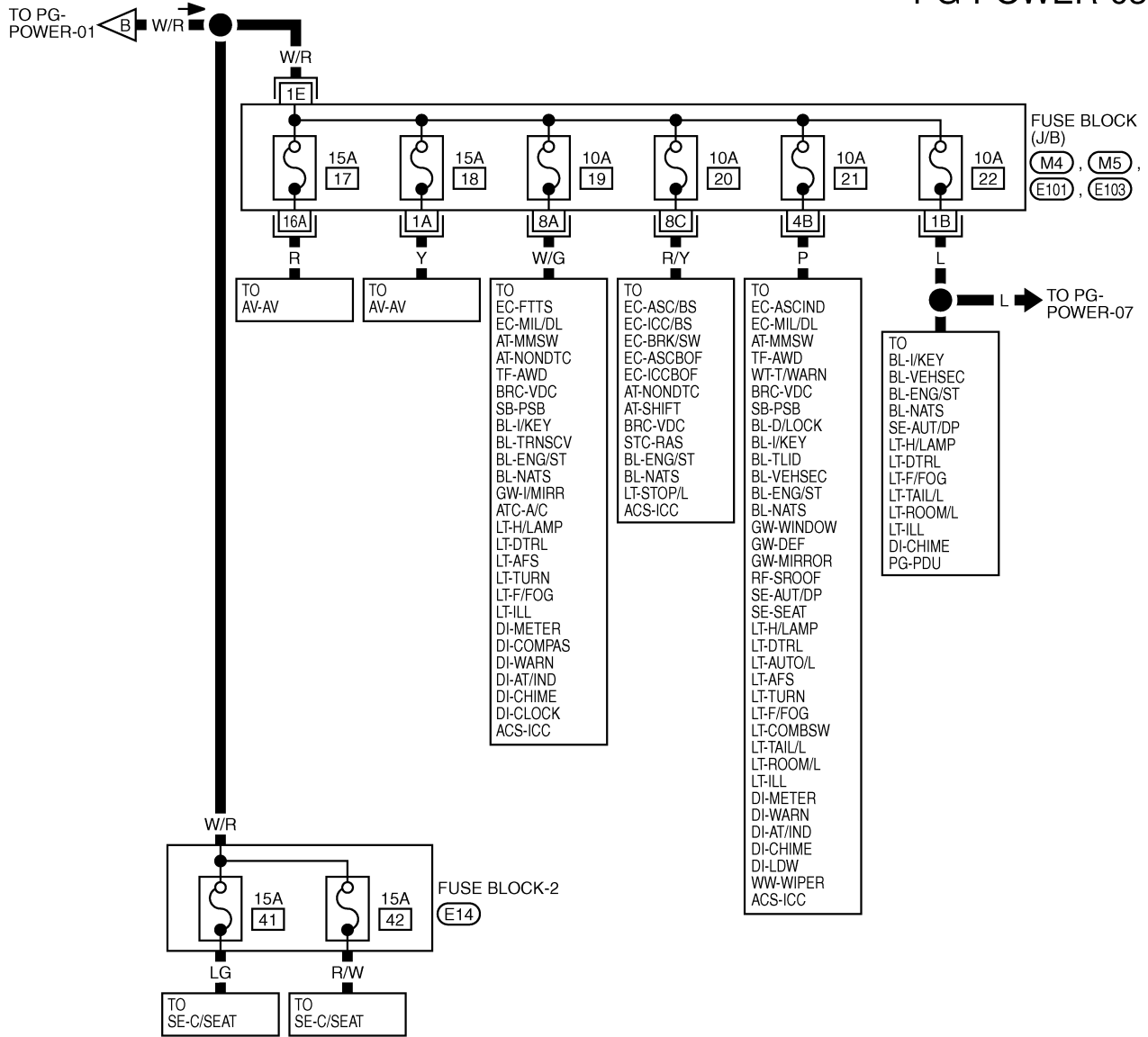

A  
B  
C  
D  
E  
F  
G  
H  
I  
J  
PG  
L  
M

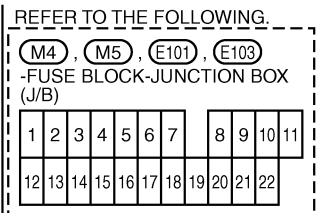
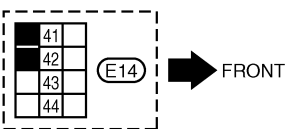

TKWT5164E

# POWER SUPPLY ROUTING CIRCUIT

PG-POWER-04

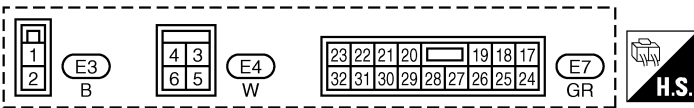
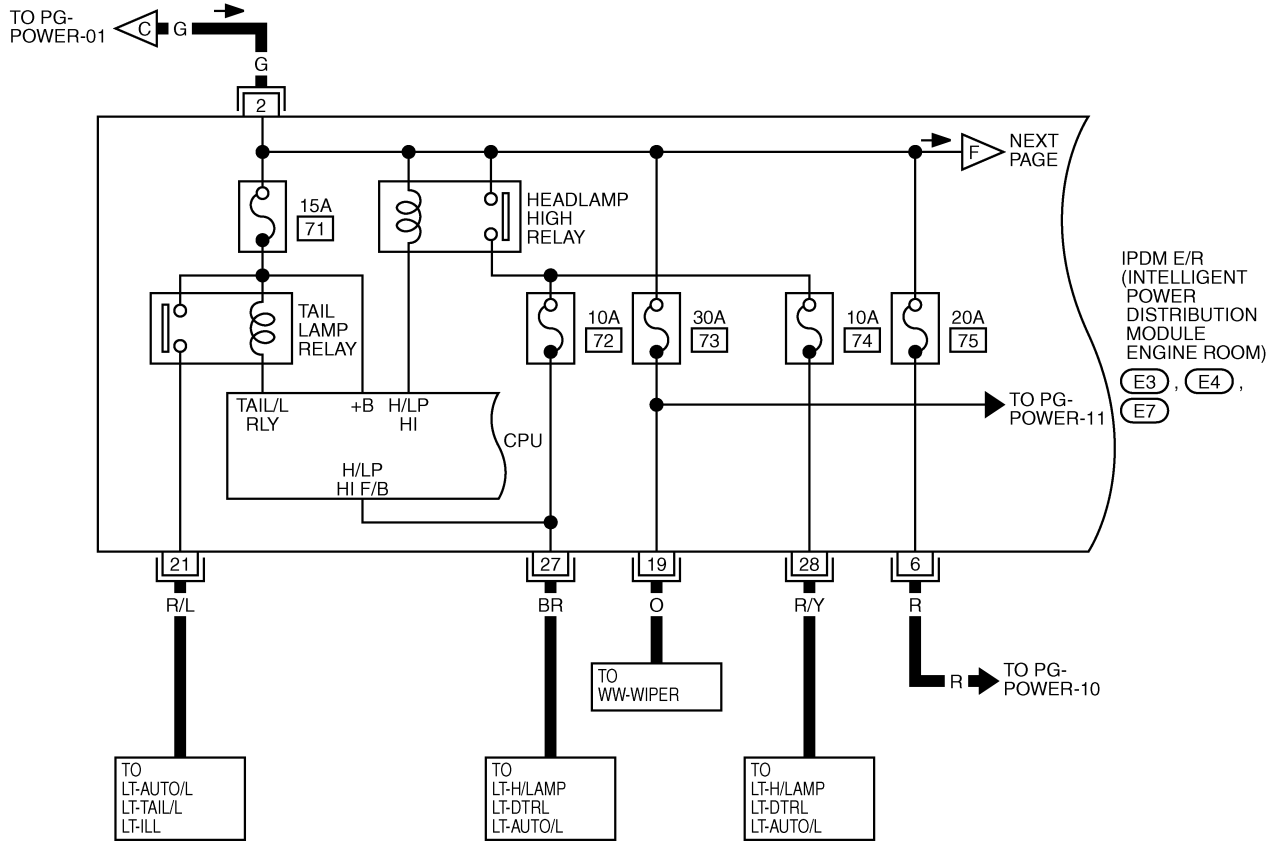

TKWT3569E



# POWER SUPPLY ROUTING CIRCUIT

PG-POWER-05

A  
B  
C  
D  
E  
F  
G  
H  
I  
J  
PG  
L  
M

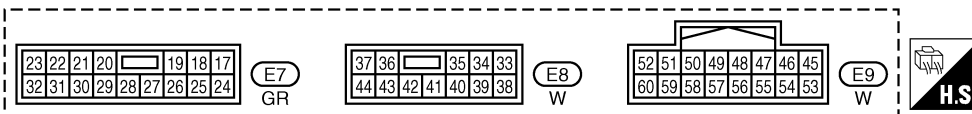
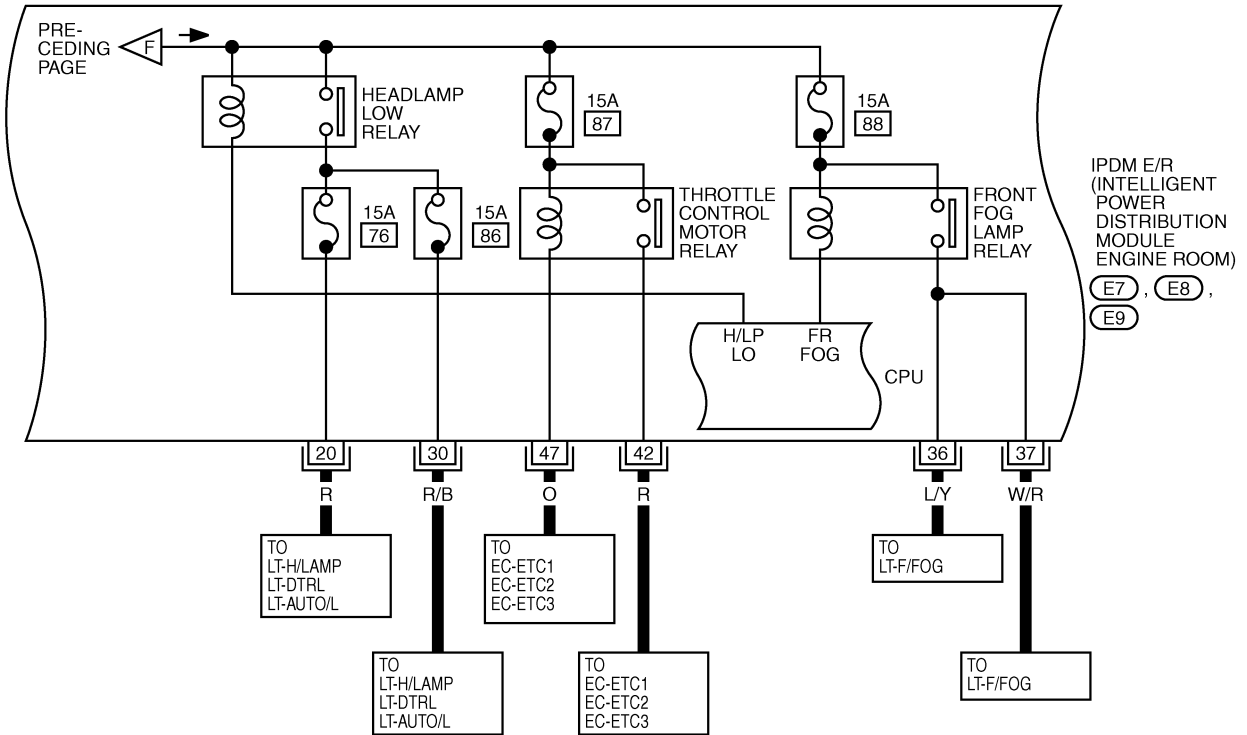

TKWT3570E

# POWER SUPPLY ROUTING CIRCUIT

PG-POWER-06

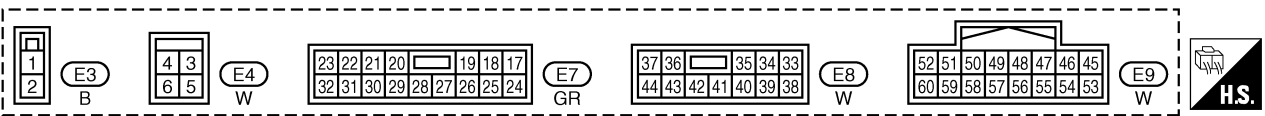
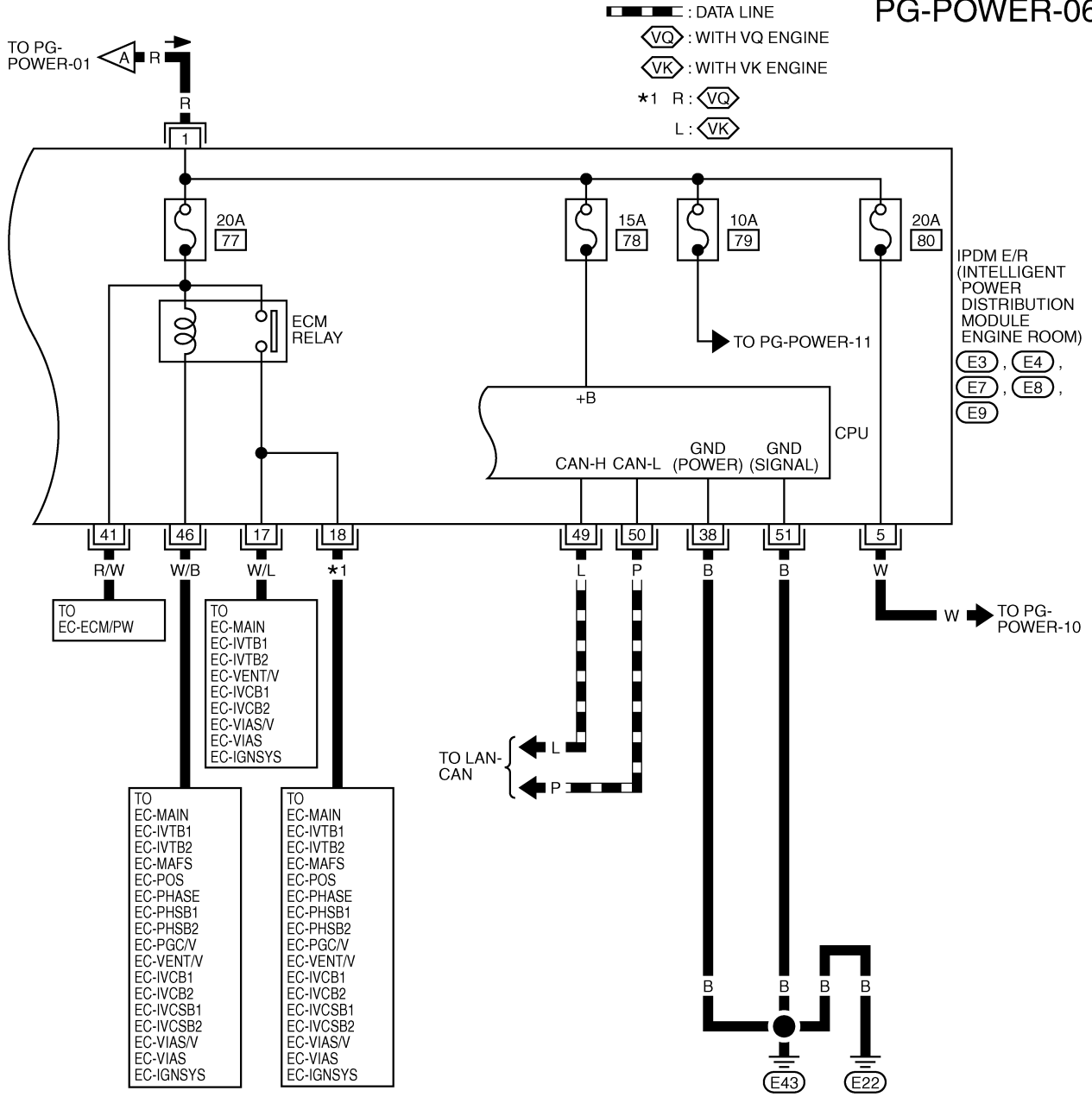

TKWT5165E

# POWER SUPPLY ROUTING CIRCUIT

## ACCESSORY POWER SUPPLY — IGNITION SW. IN “ACC” OR “ON”

PG-POWER-07

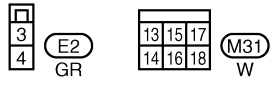
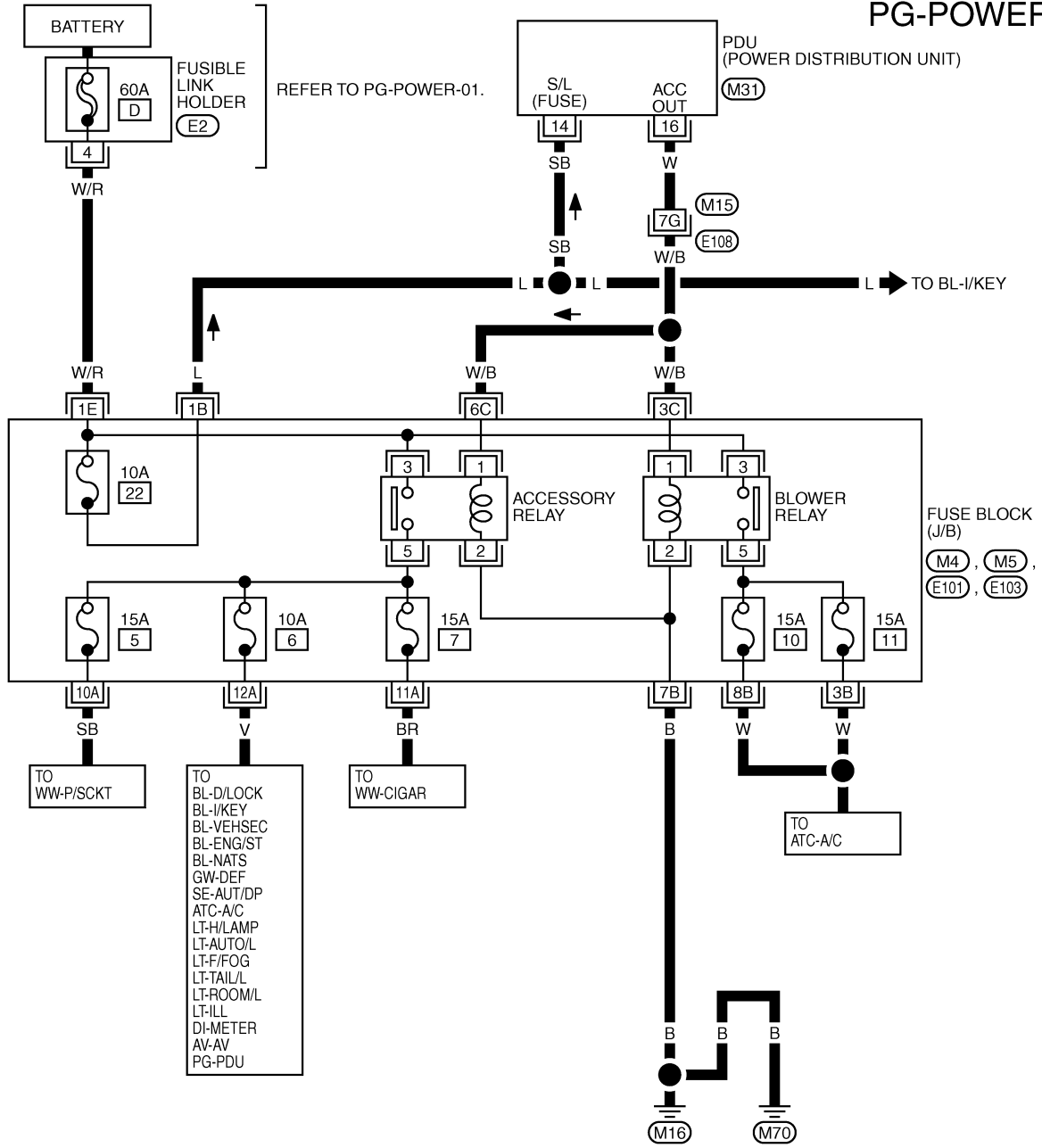

REFER TO THE FOLLOWING.

(E108) -SUPER MULTIPLE JUNCTION (SMJ)

(M4), (M5), (E101), (E103) -FUSE BLOCK-JUNCTION BOX (J/B)

1	2	3	4	5	6	7	8	9	10	11
12	13	14	15	16	17	18	19	20	21	22

TKWT3572E

# POWER SUPPLY ROUTING CIRCUIT

## IGNITION POWER SUPPLY — IGNITION SW. IN “ON” AND/OR “START”

PG-POWER-08

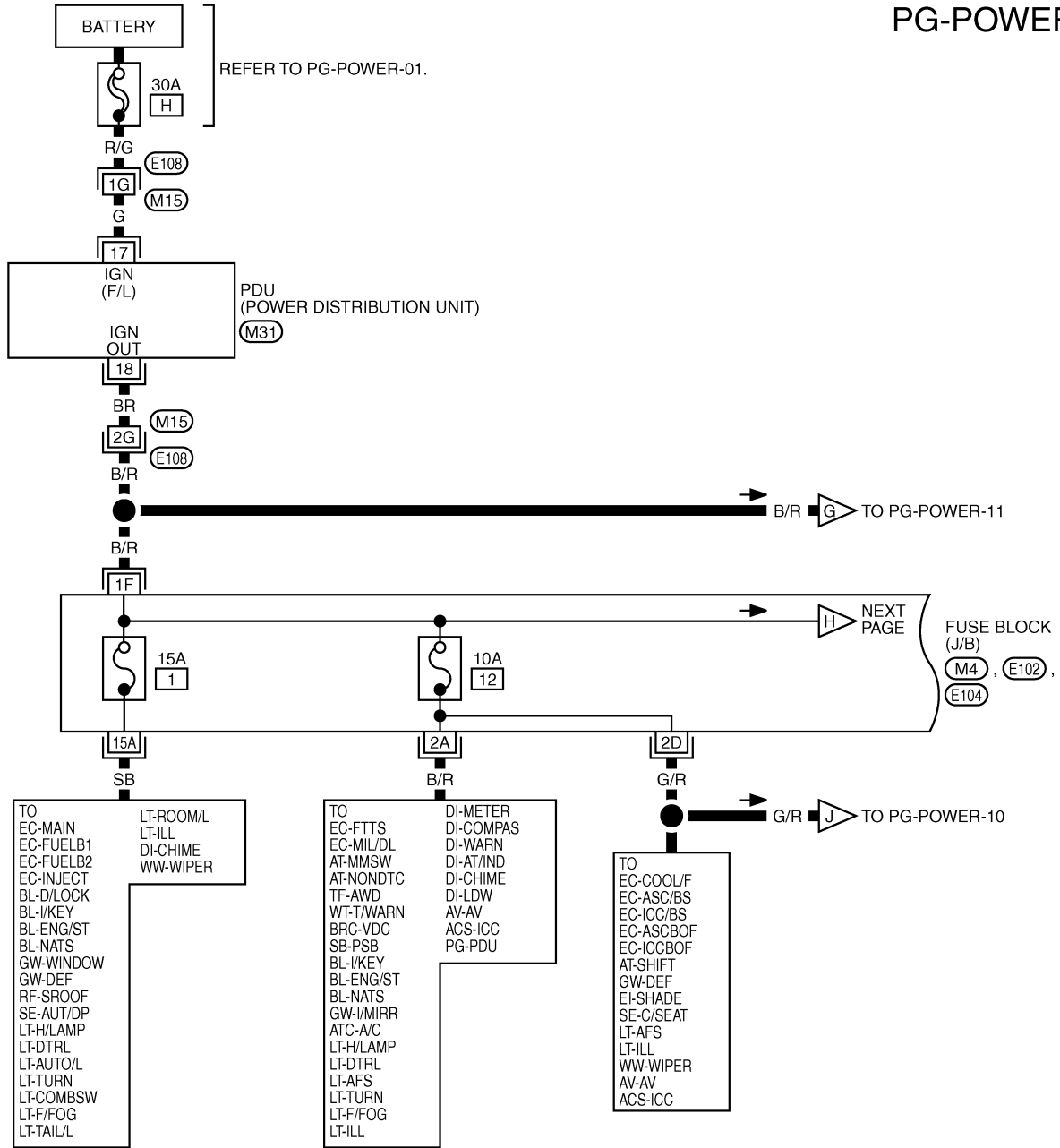

13	15	17
14	16	18

(M31)  
W

REFER TO THE FOLLOWING.

(E108) -SUPER MULTIPLE JUNCTION (SMJ)

(M4), (E102), (E104)  
-FUSE BLOCK-JUNCTION BOX (J/B)

1	2	3	4	5	6	7	8	9	10	11
12	13	14	15	16	17	18	19	20	21	22

TKWT3573E

# POWER SUPPLY ROUTING CIRCUIT

PG-POWER-09

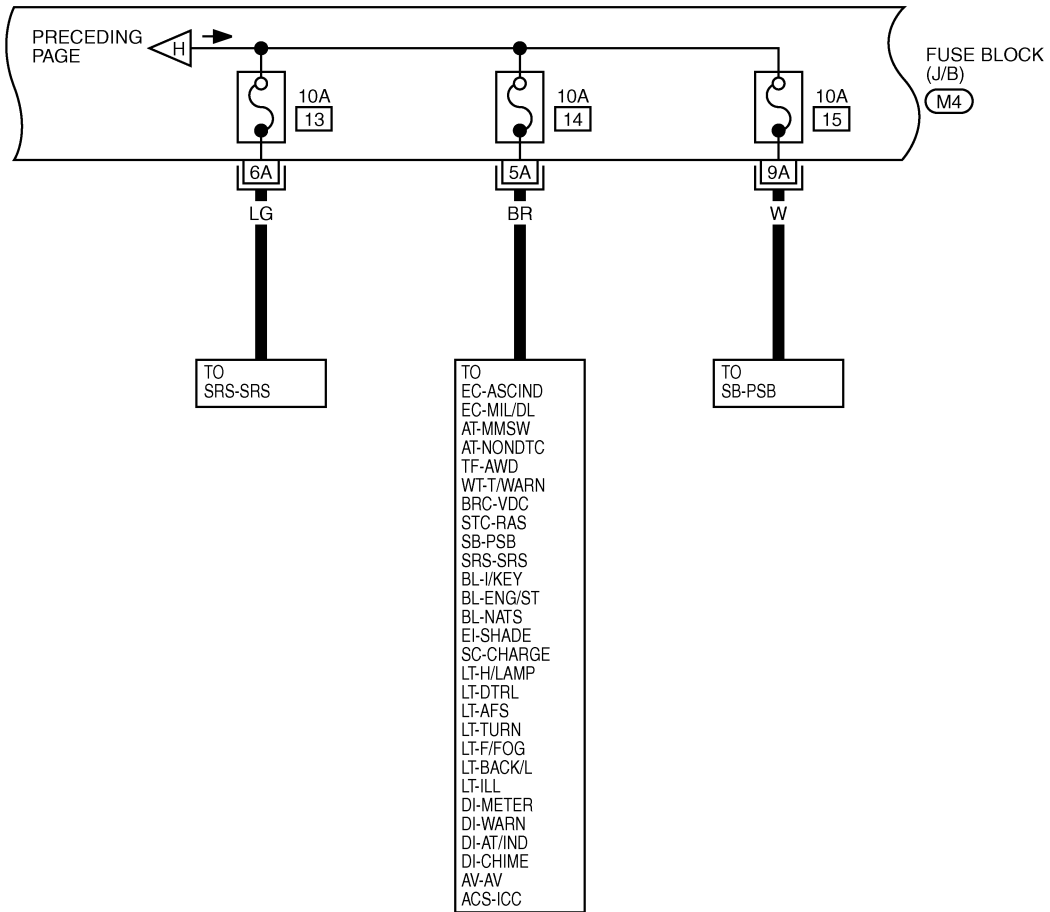

A  
B  
C  
D  
E  
F  
G  
H  
I  
J  
K  
L  
M

PG

REFER TO THE FOLLOWING.

(M4) - FUSE BLOCK-JUNCTION BOX (J/B)

1	2	3	4	5	6	7	8	9	10	11
12	13	14	15	16	17	18	19	20	21	22

TKWT3574E



# POWER SUPPLY ROUTING CIRCUIT

PG-POWER-11

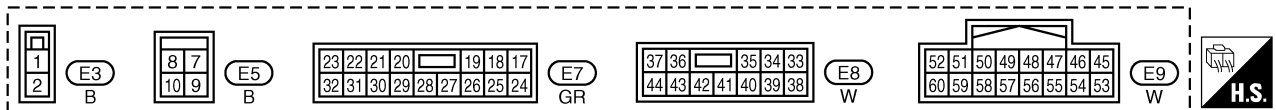
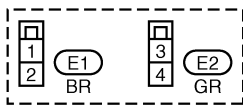
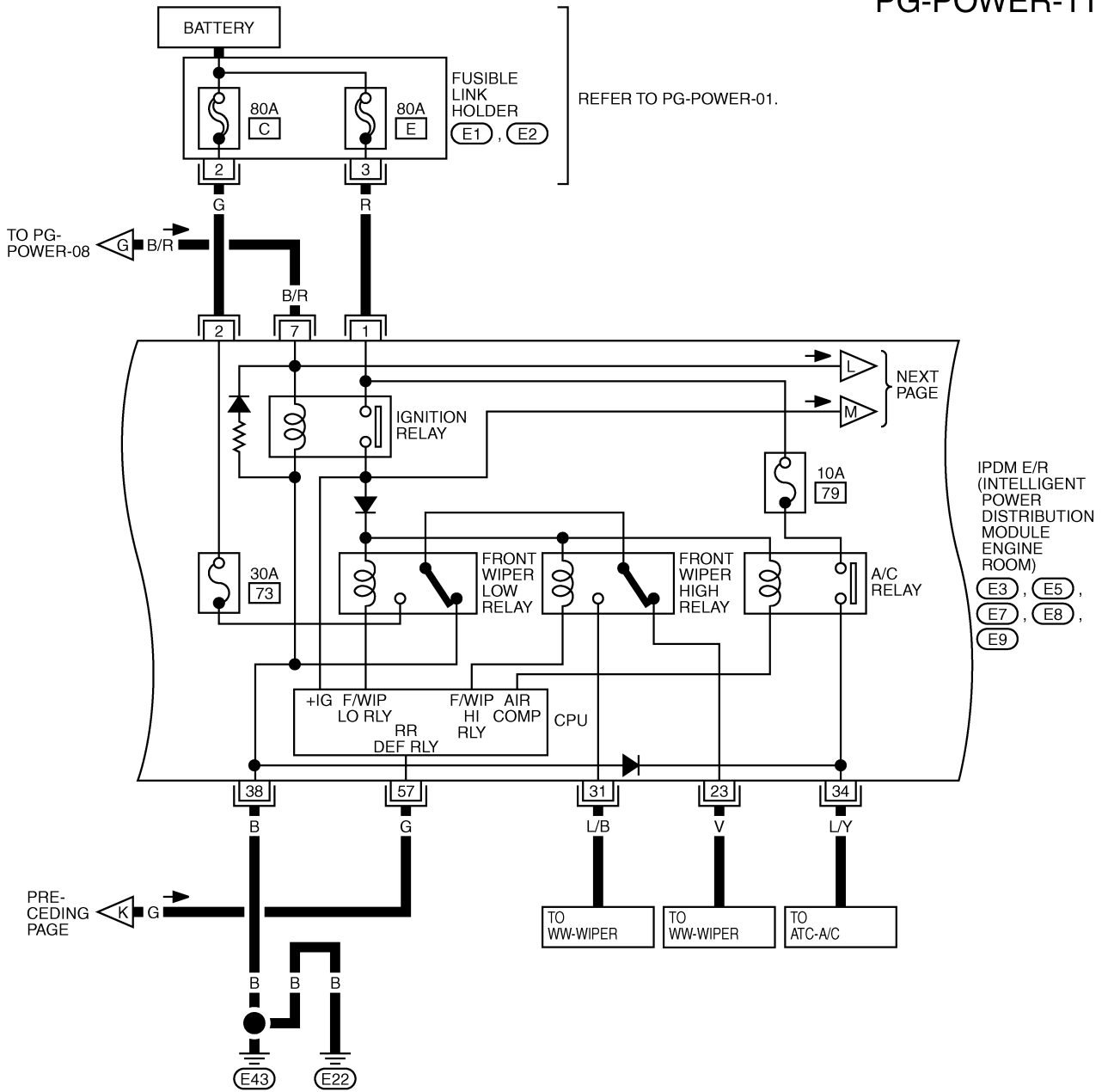

TKWT3576E

# POWER SUPPLY ROUTING CIRCUIT

PG-POWER-12

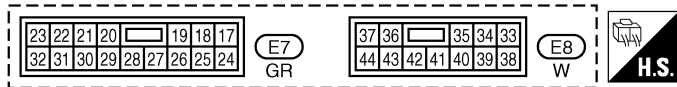
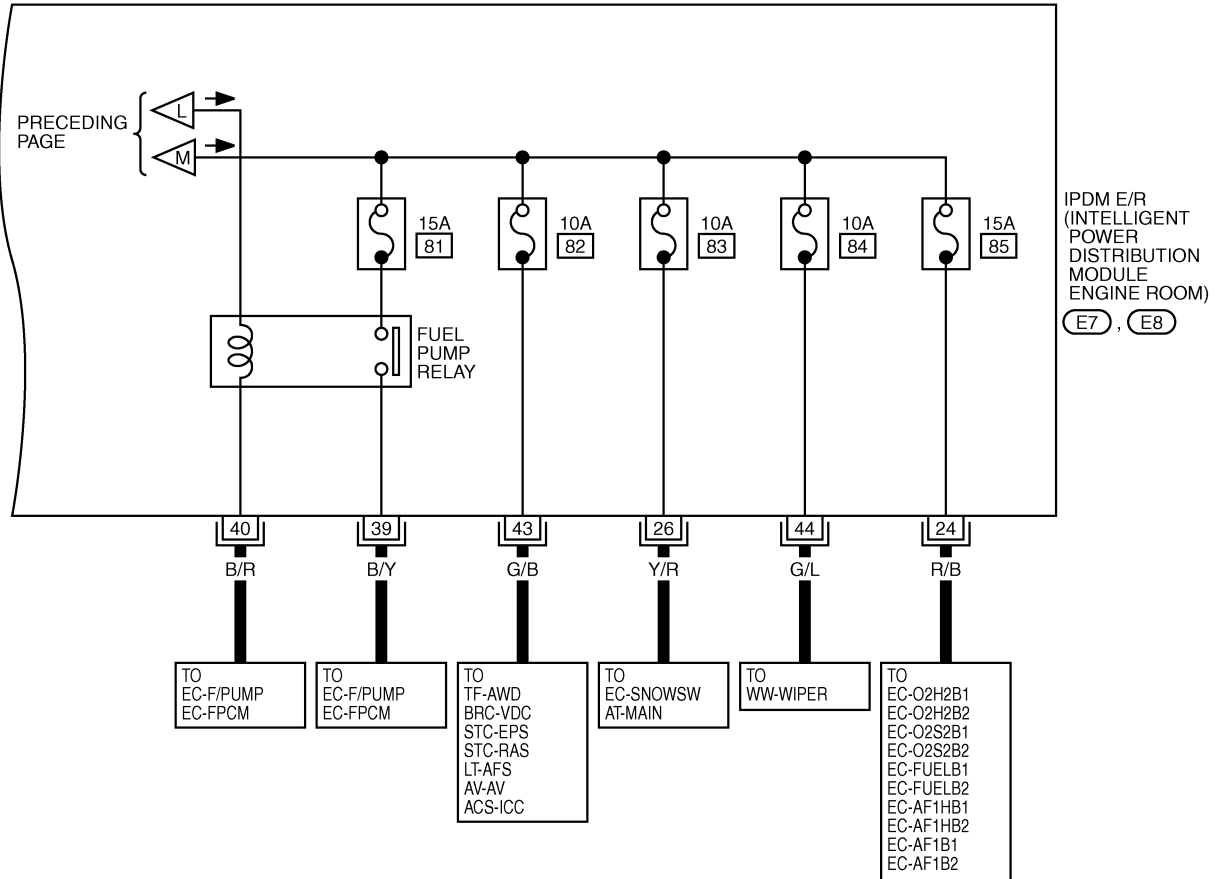

TKWT3577E



# POWER SUPPLY ROUTING CIRCUIT

## Fuse

- If fuse is blown, be sure to eliminate cause of malfunction before installing new fuse.
- Use fuse of specified rating. Never use fuse of more than specified rating.
- Do not partially install fuse; always insert it into fuse holder properly.
- Remove fuse for "ELECTRICAL PARTS (BAT)" if vehicle is not used for a long period of time.

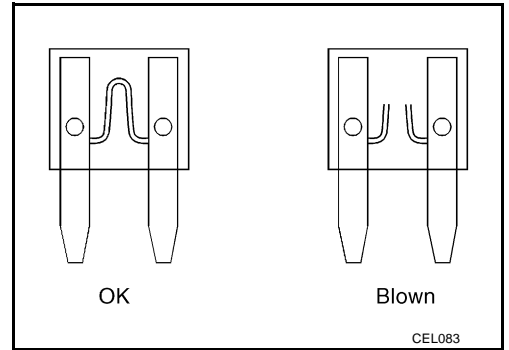

## Fusible Link

A melted fusible link can be detected either by visual inspection or by feeling with finger tip. If its condition is questionable, use circuit tester or test lamp.

### CAUTION:

- If fusible link should melt, it is possible that critical circuit (power supply or large current carrying circuit) is shorted. In such a case, carefully check and eliminate cause of malfunction.
- Never wrap outside of fusible link with vinyl tape. Important: Never let fusible link touch any other wiring harness, vinyl or rubber parts.

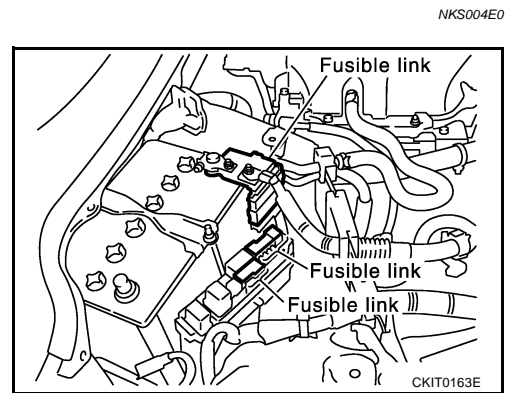

## Circuit Breaker

The PTC thermistor generates heat in response to current flow. The temperature (and resistance) of the thermistor element varies with current flow. Excessive current flow will cause the element's temperature to rise. When the temperature reaches a specified level, the electrical resistance will rise sharply to control the circuit current. Reduced current flow will cause the element to cool. Resistance falls accordingly and normal circuit current flow is allowed to resume.

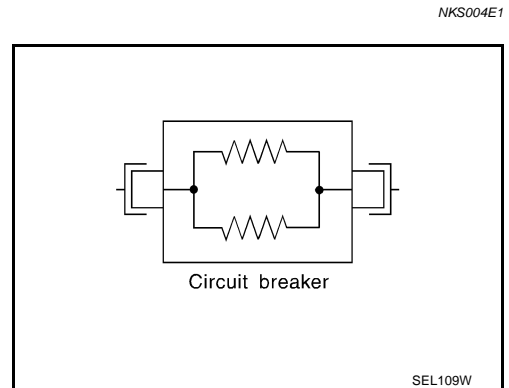

A  
B  
C  
D  
E  
F  
G  
H  
I  
J  
PG  
L  
M

## IPDM E/R (INTELLIGENT POWER DISTRIBUTION MODULE ENGINE ROOM)

PFP:284B7

### System Description

NKS004E2

- IPDM E/R (Intelligent Power Distribution Module Engine Room) integrates the relay box and fuse block which were originally placed in engine compartment. It controls integrated relay via IPDM E/R control circuit.
- IPDM E/R-integrated control circuit performs ON-OFF operation of relay, CAN communication control and oil pressure switch signal reception, etc.
- It controls operation of each electrical part via ECM, BCM and CAN communication lines.

#### CAUTION:

**None of the IPDM E/R-integrated relays can be removed.**

### SYSTEMS CONTROLLED BY IPDM E/R

1. Lamp control  
Using CAN communication, it receives signal from BCM and controls the following lamps:
  - Headlamps (HI, LO)
  - Tail, parking and license plate lamps
  - Front fog lamps
2. Daytime light relay control (for Canada models)  
Using CAN communication, it receives signals from BCM and controls the daytime light relay.
3. Wiper control  
Using CAN communication, it receives signals from BCM and controls the front wipers.
4. Rear window defogger relay control  
Using CAN communication, it receives signals from BCM and controls the rear window defogger relay.
5. A/C compressor control  
Using CAN communication, it receives signals from ECM and controls the A/C relay.
6. Cooling fan control  
Using CAN communication, it receives signals from ECM and controls cooling fan via cooling fan control module.
7. Horn control  
Using CAN communication, it receives signals from BCM and controls horn relay.
8. Starter motor relay control  
Using CAN communication, it receives signals from BCM and controls starter motor relay.
9. Alternator control  
Using CAN communication, it receives signal from ECM and controls power generation voltage.

### CAN COMMUNICATION LINE CONTROL

With CAN communication, by connecting each control unit using two communication lines (CAN L-line, CAN H-line), it is possible to transmit maximum amount of information with minimum wiring. Each control unit can transmit and receive data, and reads necessary information only.

1. Fail-safe control
  - When CAN communication with other control units is impossible, IPDM E/R performs fail-safe control. After CAN communication recovers normally, it also returns to normal control.
  - Operation of control parts by IPDM E/R during fail-safe mode is as follows:

Controlled system	Fail-safe mode
Headlamps	<ul style="list-style-type: none"> <li>● With the ignition switch ON, the headlamp low relay is ON.</li> <li>● With the ignition switch OFF, the headlamp low relay is OFF.</li> </ul>
Tail, parking and license plate lamps	<ul style="list-style-type: none"> <li>● With the ignition switch ON, the tail lamp relay is ON.</li> <li>● With the ignition switch OFF, the tail lamp relay is OFF.</li> </ul>
Cooling fan	<ul style="list-style-type: none"> <li>● With the ignition switch ON, the cooling fan HI operates.</li> <li>● With the ignition switch OFF, the cooling fan stops.</li> </ul>
Front wiper	Until the ignition switch is turned off, the front wiper LO and HI remains in the same status it was in just before fail-safe control was initiated.

# IPDM E/R (INTELLIGENT POWER DISTRIBUTION MODULE ENGINE ROOM)

Controlled system	Fail-safe mode
Rear window defogger	Rear window defogger relay OFF
A/C compressor	A/C relay OFF
Front fog lamps	Front fog lamp relay OFF

## IPDM E/R STATUS CONTROL

In order to save power, IPDM E/R switches status by itself based on each operating condition.

1. CAN communication status
  - CAN communication is normally performed with other control units.
  - Individual unit control by IPDM E/R is normally performed.
  - When sleep request signal is received from BCM, mode is switched to sleep transient status.
2. Sleep transient status
  - Process to stop CAN communication is activated.
  - All systems controlled by IPDM E/R are stopped. When 3 seconds have elapsed after CAN communication with other control units is stopped, mode switches to sleep status.
3. Sleep status
  - IPDM E/R operates in low power mode.
  - CAN communication is stopped.
  - When a change in CAN communication line is detected, mode switches to CAN communication status.
  - When a change hood switch or ignition switch signal is detected, mode switches to CAN communication status.

## CAN Communication System Description

NKS004E3

CAN (Controller Area Network) is a serial communication line for real time application. It is an on-vehicle multiplex communication line with high data communication speed and excellent error detection ability. Modern vehicles are equipped with many electronic control units and each control unit shares information and links with other control units during operation (not independent). In CAN communication, control units are connected with 2 communication lines (CAN H line, CAN L line) allowing a high rate of information transmission with less wiring. Each control unit transmits/receives data but selectively reads required data only.

## CAN Communication Unit

NKS004E4

Refer to [LAN-50, "CAN System Specification Chart"](#) .

## Function of Detecting Ignition Relay Malfunction

NKS004E5

- When contact point of integrated ignition relay is stuck and cannot be turned OFF, IPDM E/R turns ON tail and parking lamps for 10 minutes to indicate ignition relay malfunction.
- When a state of ignition relay having built-in does not agree with a state of Ignition switch signal input by a CAN communication from BCM, IPDM E/R lets tail lamp relay operate.

Ignition switch signal	Ignition relay status	Tail lamp relay
ON	ON	—
OFF	OFF	—
ON	OFF	—
OFF	ON	ON (10 minutes)

### NOTE:

When the ignition switch is turned ON, the tail lamps are OFF.

# IPDM E/R (INTELLIGENT POWER DISTRIBUTION MODULE ENGINE ROOM)

## CONSULT-II Function (IPDM E/R)

NKS004E6

CONSULT-II can display each diagnostic item using the diagnostic test modes shown following.

Inspection Item, Diagnosis Mode	Description
SELF-DIAG RESULTS	The IPDM E/R performs diagnosis of the CAN communication and self-diagnosis.
DATA MONITOR	The input/output data of the IPDM E/R is displayed in real time.
CAN DIAG SUPPORT MNTR	The result of transmit/receive diagnosis of CAN communication can be read.
ACTIVE TEST	The IPDM E/R sends a drive signal to electronic components to check their operation.

## CONSULT-II BASIC OPERATION

Refer to [GI-38, "CONSULT-II Start Procedure"](#).

### SELF-DIAG RESULTS

#### Operation Procedure

1. Touch "SELF-DIAG RESULTS" on "SELECT DIAG MODE" screen.
2. Check display content in self-diagnostic results.

#### Display Item List

Display Items	CONSULT-II display code	Malfunction detecting condition	TIME		Possible causes
			CRNT	PAST	
NO DTC IS DETECTED.FURTHER TESTING MAY BE REQUIRED.	-	-	-	-	-
CAN COMM CIRC	U1000	<ul style="list-style-type: none"> <li>● If CAN communication reception/transmission data has a malfunction, or if any of the control units malfunction, data reception/transmission cannot be confirmed.</li> <li>● When the data in CAN communication is not received before the specified time</li> </ul>	×	×	Any of or several items below have errors. <ul style="list-style-type: none"> <li>● TRANSMIT DIAG</li> <li>● ECM</li> <li>● BCM/SEC</li> </ul>

#### NOTE:

The details for display of the period are as follows:

- CRNT: Error currently detected with IPDM E/R.
- PAST: Error detected in the past and memorized with IPDM E/R.

# IPDM E/R (INTELLIGENT POWER DISTRIBUTION MODULE ENGINE ROOM)

## DATA MONITOR

### Operation Procedure

1. Touch "DATA MONITOR" on "SELECT MONITOR ITEM" screen.
2. Touch "ALL SIGNALS", "MAIN SIGNALS" or "SELECTION FROM MENU" on the "DATA MONITOR" screen.

ALL SIGNALS	All items will be monitored.
MAIN SIGNALS	Monitor the predetermined item.
SELECTION FROM MENU	Select any item for monitoring.

3. Touch the required monitoring item on "SELECTION FROM MENU". In "ALL SIGNALS", all items are monitored. In "MAIN SIGNALS", predetermined items are monitored.
4. Touch "START".
5. Touch "RECORD" while monitoring to record the status of the item being monitored. To stop recording, touch "STOP".

### All Signals, Main Signals, Selection From Menu

Item name	CONSULT-II screen display	Display or unit	Monitor item selection			Description
			ALL SIGNALS	MAIN SIGNALS	SELECTION FROM MENU	
Motor fan request	MOTOR FAN REQ	1/2/3/4	×	×	×	Signal status input from ECM
A/C Compressor request	AC COMP REQ	ON/OFF	×	×	×	Signal status input from ECM
Tail & clearance request	TAIL&CLR REQ	ON/OFF	×	×	×	Signal status input from BCM
Headlamp LO request	HL LO REQ	ON/OFF	×	×	×	Signal status input from BCM
Headlamp HI request	HL HI REQ	ON/OFF	×	×	×	Signal status input from BCM
Front fog lamp request	FR FOG REQ	ON/OFF	×	×	×	Signal status input from BCM
Front wiper request	FR WIP REQ	STOP/1LOW/LOW/HI	×	×	×	Signal status input from BCM
Wiper auto stop	WIP AUTO STOP	ACT P/STOP P	×	×	×	Output status of IPDM E/R
Wiper protection	WIP PROT	OFF/BLOCK	×	×	×	Control status of IPDM E/R
Starter request	ST RLY REQ	ON/OFF	×		×	Signal status input from BCM
Ignition relay status	IGN RLY	ON/OFF	×	×	×	Ignition relay status monitored with IPDM E/R
Rear window defogger request	RR DEF REQ	ON/OFF	×	×	×	Signal status input from BCM
Oil pressure switch	OIL P SW	OPEN/CLOSE	×		×	Signal status input in IPDM E/R
Daytime running light request	DTRL REQ*1	ON/OFF	×		×	Signal status input from BCM
Hood switch	HOOD SW	ON/OFF	×		×	Signal status input in IPDM E/R
Theft warning horn request	THFT HRN REQ	ON/OFF	×		×	Signal status input from BCM
Horn chirp	HORN CHIRP	ON/OFF	×		×	Output status of IPDM E/R

#### NOTE:

- Perform monitoring of IPDM E/R data with the ignition switch ON. When the ignition switch is at ACC, the display may not be correct.
- \*1: Only the vehicle with day time light system operates.

# IPDM E/R (INTELLIGENT POWER DISTRIBUTION MODULE ENGINE ROOM)

## CAN DIAG SUPPORT MNTR

Refer to [LAN-44, "CAN Diagnostic Support Monitor"](#) in LAN section.

### ACTIVE TEST

#### Operation Procedure

1. Touch "ACTIVE TEST" on "SELECT DIAG MODE" screen.
2. Touch item to be tested.
3. Touch "START", and confirm its operation.
4. Touch "STOP" while testing to stop the operation.

Test item	CONSULT-II screen display	Description
Tail lamp operation	TAIL LAMP	With a certain ON-OFF operation, the tail lamp relay can be operated.
Rear window defogger operation	REAR DEFOGGER	With a certain ON-OFF operation, the rear window defogger relay can be operated.
Front wiper (HI, LO) operation	FRONT WIPER	With a certain operation (OFF, HI ON, LO ON), the front wiper relay (Lo, Hi) can be operated.
Cooling fan operation	MOTOR FAN	With a certain operation (1, 2, 3, 4), the cooling fan can be operated.
Lamp (HI, LO, FOG) operation	LAMPS	With a certain operation (OFF, HI ON, LO ON, FOG ON), the lamp relay (Lo, Hi, Fog) can be operated.
Horn operation	HORN	Push "ON" button, horn relay operates 20ms.

## Auto Active Test DESCRIPTION

NKS004E7

In auto active test mode, operation inspection can be performed when IPDM E/R sends a drive signal to the following systems:

- Rear window defogger
- Front wiper (LO, HI)
- Tail lamps, parking lamps and license plate lamps
- Front fog lamps
- Headlamps (LO, HI)
- A/C compressor (magnetic clutch)
- Cooling fan
- Oil pressure warning lamp

## OPERATION PROCEDURE

1. Close hood and front door (passenger side), and then lift wiper arms away from windshield (to prevent glass damage by wiper operation).

### NOTE:

When auto active test is performed with hood opened, sprinkle water on windshield beforehand.

2. Turn ignition switch OFF.
3. Turn ignition switch ON, and within 20 seconds, press driver's door switch 10 times (close other doors). Then turn ignition switch OFF.
4. Turn ignition switch ON within 10 seconds after ignition switch OFF.
5. When auto active test mode is actuated, horn chirps once. Oil pressure warning lamp starts blinking.
6. After a series of operations is repeated three times, auto active test is completed.

### NOTE:

When auto active test mode has to be cancelled halfway, turn ignition switch OFF.

### CAUTION:

- **Never start the engine.**
- **If the engine starting operation is made, delete DTC on the self-diag results of CONSULT-II. Refer to [BL-79, "CONSULT-II Application Items"](#) .**
- **Be sure to inspect [GW-50, "Check door Switch"](#) when the auto active test cannot be performed.**

# IPDM E/R (INTELLIGENT POWER DISTRIBUTION MODULE ENGINE ROOM)

## INSPECTION IN AUTO ACTIVE TEST MODE

When auto active test mode is actuated, the following eight steps are repeated three times.

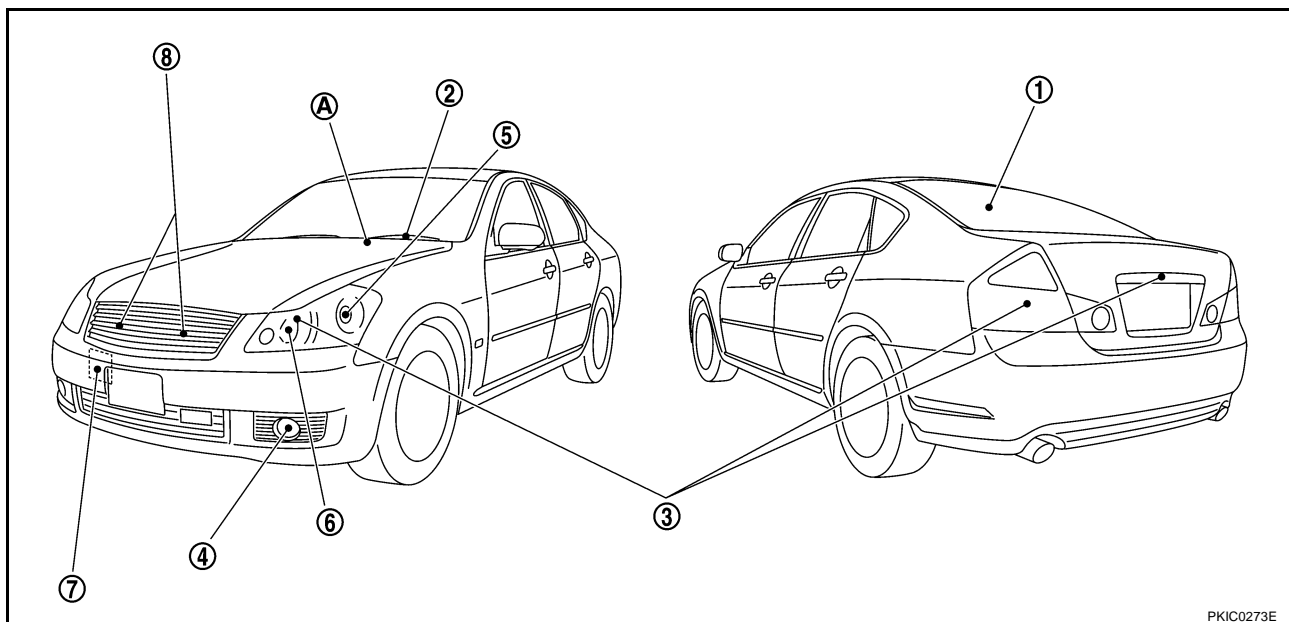

(A): Oil pressure warning lamp is blinking when the auto active test operating.

### Operation steps

	Test item	Operation time/ frequency
1	Rear window defogger	10 seconds
2	Front wiper	LO 5 seconds → HI 5 seconds
3	Tail lamps, parking lamps, license plate lamps	10 seconds
4	Front fog lamps	10 seconds
5	Headlamp (LO)	10 seconds
6	Headlamp (HI)	ON-OFF 5 times
7	A/C compressor (magnetic clutch)	ON-OFF 5 times
8	Cooling fan	LO 5 seconds → HI 5 seconds



# IPDM E/R (INTELLIGENT POWER DISTRIBUTION MODULE ENGINE ROOM)

## Concept of Auto Active Test

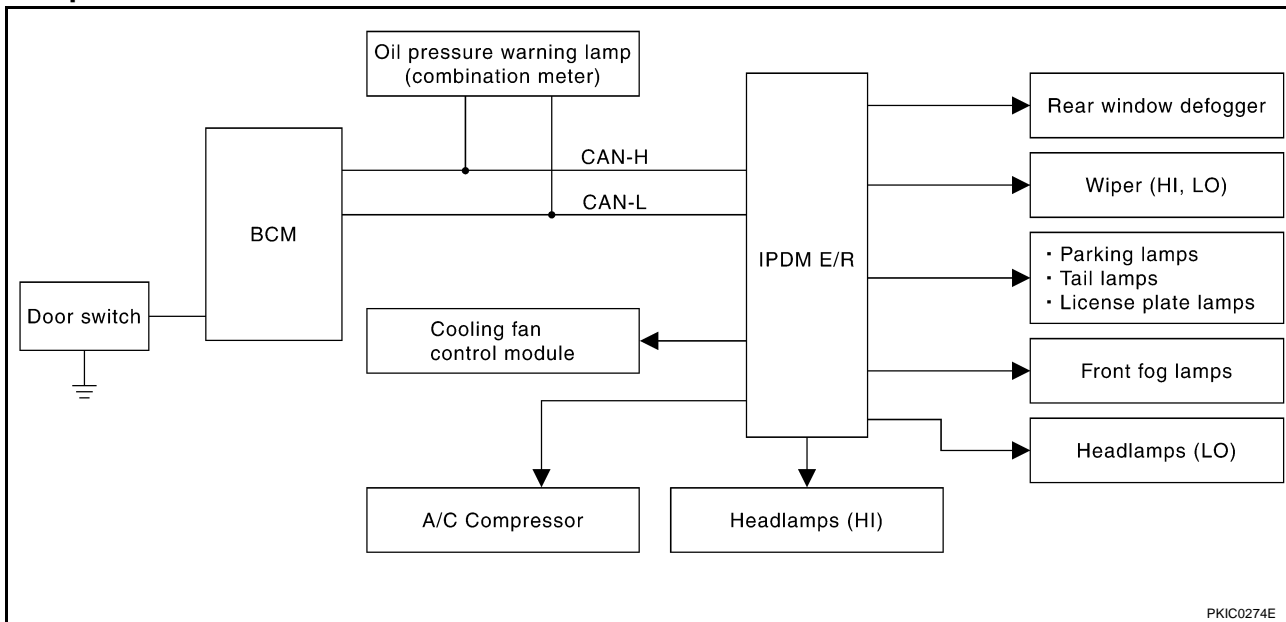

- IPDM E/R actuates auto active test mode when it receives door switch signal from BCM via CAN communication line. Therefore, when auto active test mode is activated successfully, CAN communication between IPDM E/R and BCM is normal.
- If any of systems controlled by IPDM E/R cannot be operated, possible cause can be easily diagnosed using auto active test.

### Diagnosis chart in auto active test mode

Symptom	Inspection contents	Possible cause
Any of front wipers, tail lamps, parking lamps, front fog lamps, and head lamps (HI, LO) do not operate.	YES	● BCM signal input system malfunction
	NO	<ul style="list-style-type: none"> <li>● Lamp/wiper motor malfunction</li> <li>● Lamp/wiper motor ground circuit malfunction</li> <li>● Harness/connector malfunction between IPDM E/R and system in question</li> <li>● IPDM E/R (integrated relay) malfunction</li> </ul>
Rear window defogger does not operate.	YES	● BCM signal input circuit malfunction
	NO	<ul style="list-style-type: none"> <li>● Rear window defogger relay malfunction</li> <li>● Harness/connector malfunction between IPDM E/R and rear window defogger relay</li> <li>● Open circuit of rear window defogger</li> <li>● IPDM E/R malfunction</li> </ul>
A/C compressor does not operate.	YES	<ul style="list-style-type: none"> <li>● BCM signal input circuit malfunction</li> <li>● CAN communication signal malfunction between BCM and ECM.</li> <li>● CAN communication signal malfunction between ECM and IPDM E/R</li> </ul>
	NO	<ul style="list-style-type: none"> <li>● Magnetic clutch malfunction</li> <li>● Harness/connector malfunction between IPDM E/R and magnetic clutch</li> <li>● IPDM E/R (integrated relay) malfunction</li> </ul>

# IPDM E/R (INTELLIGENT POWER DISTRIBUTION MODULE ENGINE ROOM)

Symptom	Inspection contents	Possible cause
Cooling fan does not operate.	Perform auto active test. Does cooling fan operate?	YES <ul style="list-style-type: none"> <li>● ECM signal input circuit malfunction</li> <li>● CAN communication signal malfunction between ECM and IPDM E/R</li> </ul>
		NO <ul style="list-style-type: none"> <li>● Cooling fan motor malfunction</li> <li>● Harness/connector malfunction between cooling fan motor and cooling fan control module</li> <li>● Cooling fan control module malfunction</li> <li>● Harness/connector malfunction between IPDM E/R and cooling fan control module</li> <li>● Cooling fan relay malfunction</li> <li>● Harness/connector malfunction between IPDM E/R and cooling fan relay</li> <li>● IPDM E/R malfunction</li> </ul>
Oil pressure warning lamp does not operate.	Perform auto active test. Does oil pressure warning lamp blink?	YES <ul style="list-style-type: none"> <li>● Harness/connector malfunction between IPDM E/R and oil pressure switch</li> <li>● Oil pressure switch malfunction</li> <li>● IPDM E/R malfunction</li> </ul>
		NO <ul style="list-style-type: none"> <li>● CAN communication signal malfunction between IPDM E/R and unified meter and A/C amp.</li> <li>● Combination meter malfunction</li> </ul>

# IPDM E/R (INTELLIGENT POWER DISTRIBUTION MODULE ENGINE ROOM)

## Schematic

NKS004E8

A  
B  
C  
D  
E  
F  
G  
H  
I  
J  
PG  
L  
M

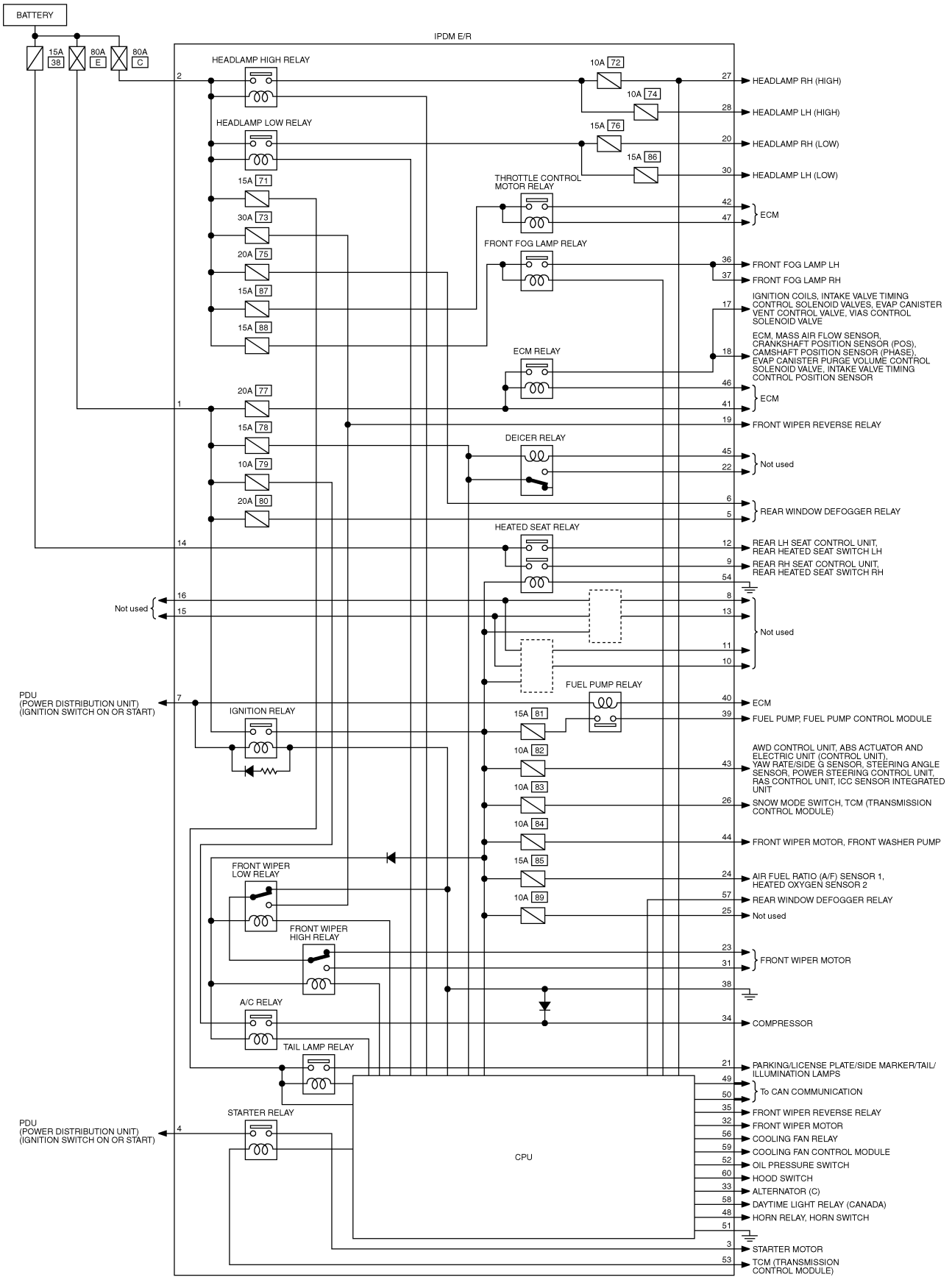

TKWT5166E

## IPDM E/R Terminal Arrangement

NKS004E9

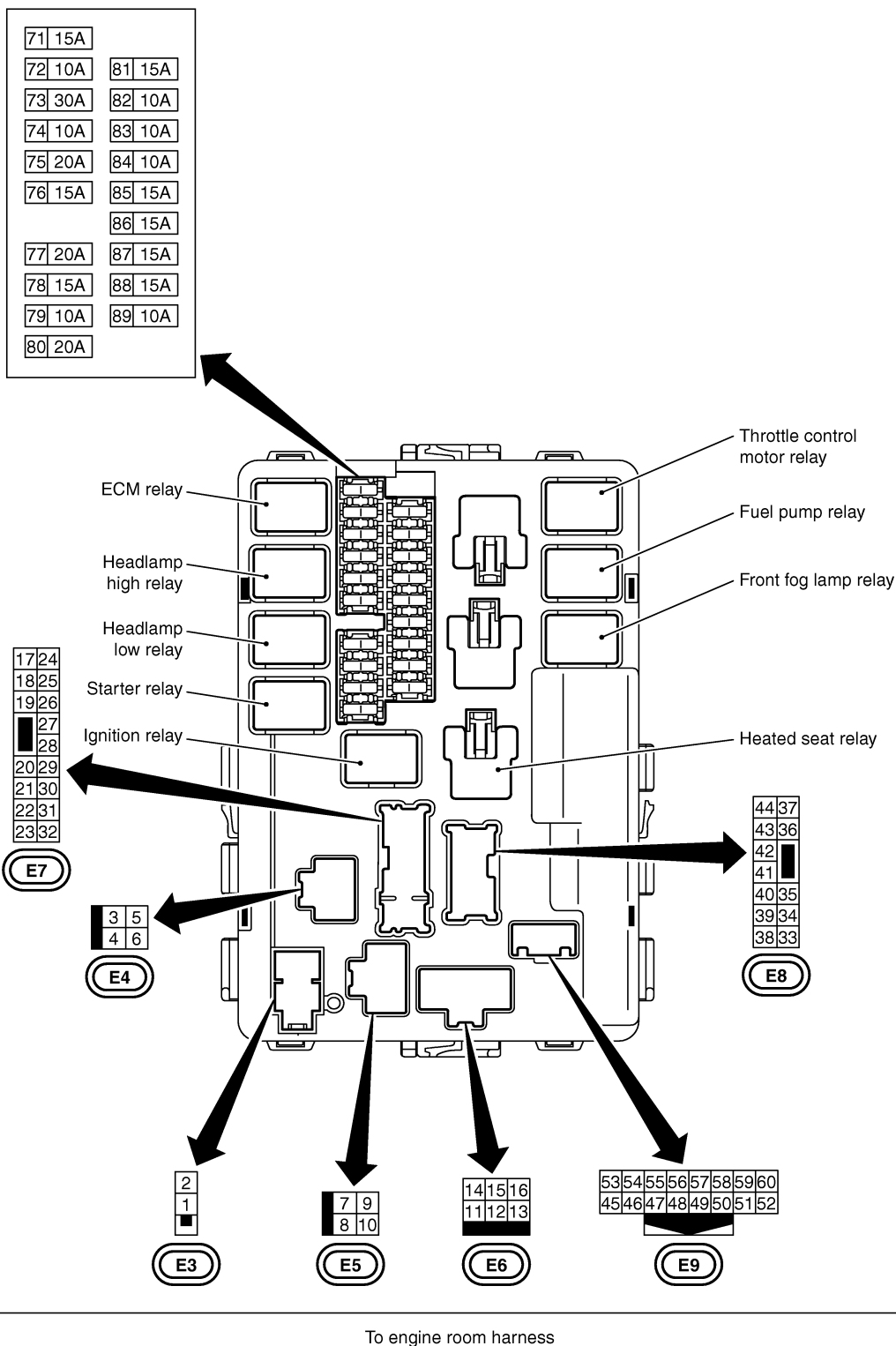

CKIT0665E

# IPDM E/R (INTELLIGENT POWER DISTRIBUTION MODULE ENGINE ROOM)

## Check IPDM E/R Power Supply and Ground Circuit

NKS004EA

### 1. CHECK FUSES AND FUSIBLE LINKS

Check for blown fuses and fusible link.

Terminal No.	Power source	Fuse and fusible link No.
1	Battery	E
2		C
—		71
—		78

OK or NG

OK >> GO TO 2.

NG >> If fuse or fusible link is blown, be sure to eliminate cause of malfunction before installing new fuse or fusible link.

### 2. CHECK POWER SUPPLY CIRCUIT

1. Turn ignition switch OFF.
2. Disconnect IPDM E/R harness connector.
3. Check voltage between IPDM E/R harness connector and ground.

Terminals		Voltage
(+)	(-)	
IPDM E/R connector	Terminal	Ground
E3	1	
	2	Battery voltage

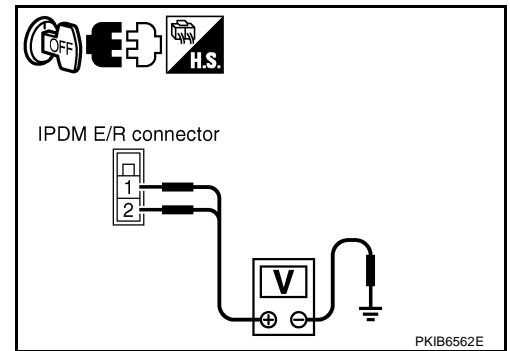

OK or NG

OK >> GO TO 3.

NG >> Repair harness or connector.

### 3. CHECK GROUND CIRCUIT

1. Disconnect IPDM E/R harness connectors.
2. Check continuity between IPDM E/R harness connectors and ground.

IPDM E/R connector	Terminal	Ground	Continuity
E8	38		Ground
E9	51		
	54		

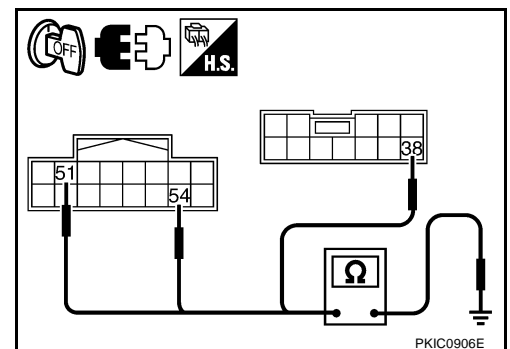

OK or NG

OK >> INSPECTION END

NG >> Repair harness or connector.

# IPDM E/R (INTELLIGENT POWER DISTRIBUTION MODULE ENGINE ROOM)

## Inspection with CONSULT-II (Self-Diagnosis)

NKS004EB

### CAUTION:

If CONSULT-II is used with no connection of CONSULT-II CONVERTER, malfunctions might be detected in self-diagnosis depending on control unit which carry out CAN communication.

### 1. CHECK SELF DIAGNOSTIC RESULT

1. Connect CONSULT-II and select "IPDM E/R" on the "SELECT SYSTEM" screen.
2. Select "SELF-DIAG RESULTS" on the "SELECT DIAG MODE" screen.
3. Check display content in self diagnostic results.

CONSULT-II display	CONSULT-II display code	TIME		Details of diagnosis result
		CRNT	PAST	
NO DTC IS DETECTED. FURTHER TESTING MAY BE REQUIRED.	-	-	-	No malfunction
CAN COMM CIRC	U1000	×	×	Any of or several items below have errors. <ul style="list-style-type: none"><li>● TRANSMIT DIAG</li><li>● ECM</li><li>● BCM/SEC</li></ul>

#### NOTE:

The details for display of the period are as follows:

- CRNT: Error currently detected with IPDM E/R.
- PAST: Error detected in the past and memorized with IPDM E/R.

#### Contents displayed

NO DTC IS DETECTED.FURTHER TESTING MAY BE REQUIRED.>>INSPECTION END

CAN COMM CIRC>>After print-out of the monitor items, refer to [LAN-50, "CAN System Specification Chart"](#) .

# IPDM E/R (INTELLIGENT POWER DISTRIBUTION MODULE ENGINE ROOM)

## Removal and Installation of IPDM E/R

NKS004EC

↔: Vehicle front

### REMOVAL

1. Remove cowl top cover (RH). Refer to [EI-18, "COWL TOP"](#).
2. Disengage pawls (A) on both side of IPDM E/R cover B (1), remove IPDM E/R cover A (2).

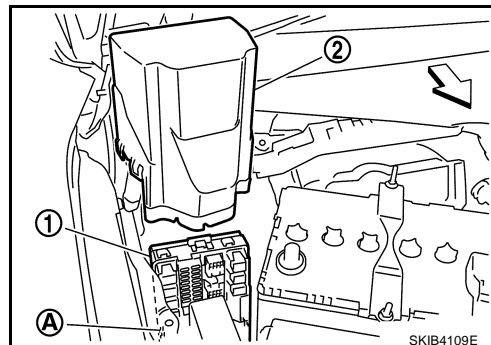

3. While pushing pawl (A) on backside of IPDM E/R cover B (1) toward vehicle front to unlock, lift up IPDM E/R (2).

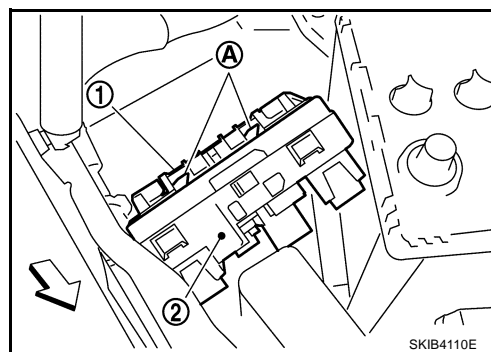

4. Disengage pawls on both side of IPDM E/R (1), remove IPDM E/R cover B.
5. Remove harness connector from IPDM E/R (1) and remove IPDM E/R (1).

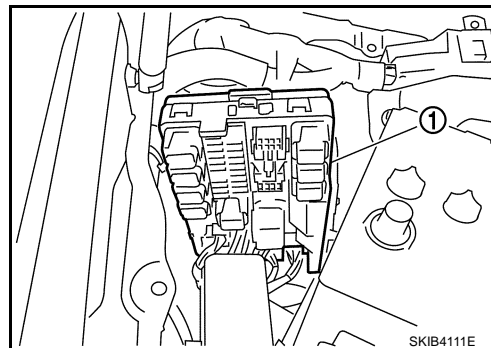

### INSTALLATION

Installation is the reverse order of removal.

A  
B  
C  
D  
E  
F  
G  
H  
I  
J  
PG  
L  
M

# PDU (POWER DISTRIBUTION UNIT)

## PDU (POWER DISTRIBUTION UNIT)

PF2:285F1

### Component Parts and Harness Connector Location

NKS004ED

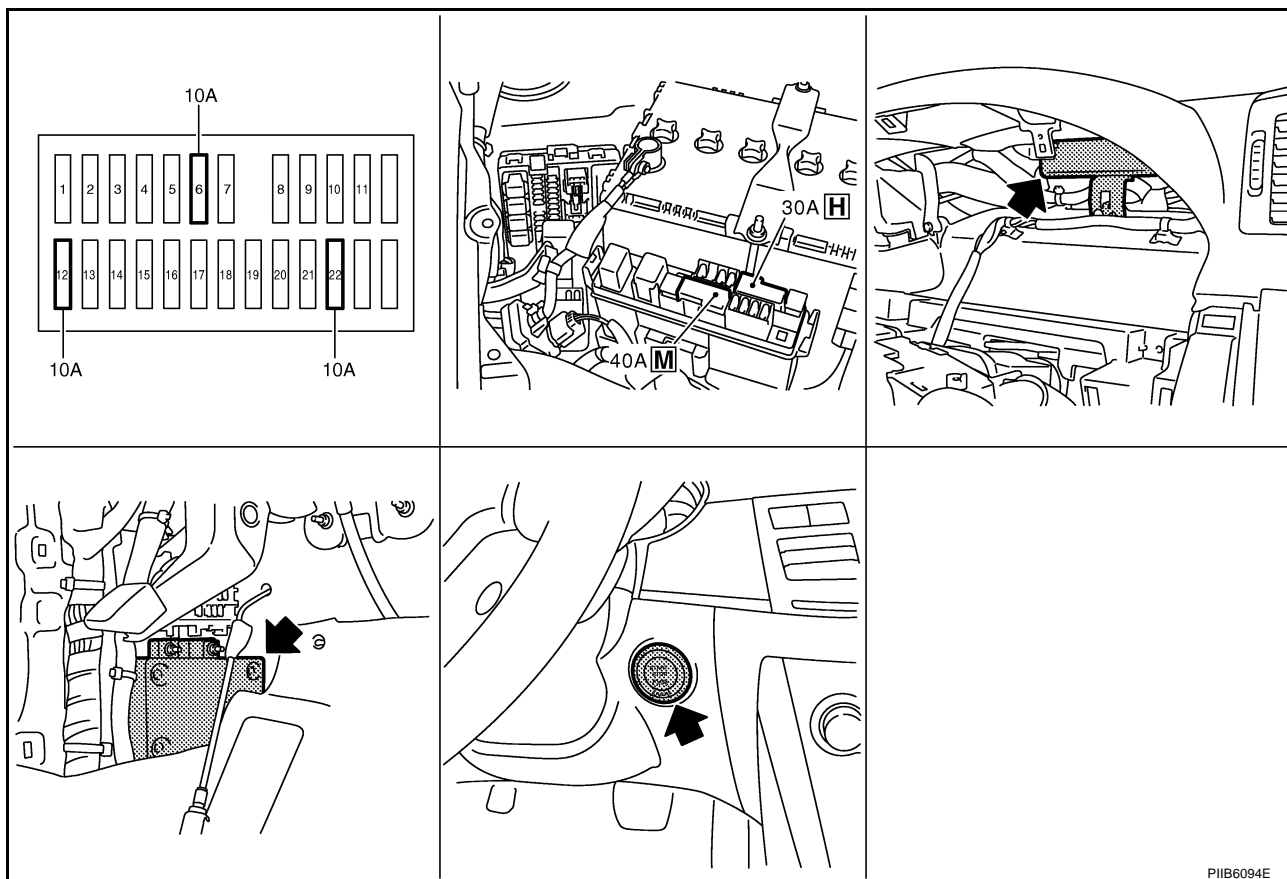

PIIB6094E

## System Description

NKS004EE

- PDU (Power Distribution Unit) is the unit that executes the power distribution with the control signal from the Intelligent Key unit, instead of the mechanical power supply mechanism by conventional key cylinder.
- The push-button ignition switch is operable when the Intelligent Key is within the detection area of the interior antenna or is inserted to the key slot.
- The push-button ignition switch operation is input to the Intelligent Key unit as a request signal. Then, the Intelligent Key unit processes the request signal and orders the PDU to switch into the appropriate power supply position.

### NOTE:

The prerequisite for starting the engine varies by the state of brake pedal, A/T selector lever, and vehicle speed.

- PDU distributes power to each power supply circuit according to the request signal received.
- The power supply position can be confirmed by illumination of the indicators in the upper surroundings of the push-button ignition switch.

## PUSH-BUTTON IGNITION SWITCH OPERATING PROCEDURE

The power supply position switching operation can be performed by the following operation.

### NOTE:

- When an Intelligent Key is within the detection area of inside antenna and when it is inserted to the key slot, it is equivalent to the operations below.
- When starting the engine, the Intelligent Key unit monitors the engine start conditions (brake pedal operating condition, A/T selector lever position, and vehicle speed).



## PDU (POWER DISTRIBUTION UNIT)

- Unless each start condition is fulfilled, the engine will not response regardless of how many times the push-button ignition switch is pushed. At that time, illumination repeats the position in the order of LOCK → ACC → ON → LOCK.

Power supply position	Engine start/stop condition		Push-button ignition switch operation frequency
	Brake pedal operation condition	A/T selector lever position	
LOCK → ACC	Not depressed (When A/T selector lever is in any position other than P or N, there will be no effect even if it is depressed.)	Any position other than P or N (When the brake pedal is not depressed, there will be no effect even if the A/T selector lever is in P or N position.)	1
LOCK → ACC → ON	Not depressed (When A/T selector lever is in any position other than P or N, there will be no effect even if it is depressed.)	Any position other than P or N (When the brake pedal is not depressed, there will be no effect even if the A/T selector lever is in P or N position.)	2
LOCK → ACC → ON → LOCK	Not depressed (When A/T selector lever is in any position other than P or N, there will be no effect even if it is depressed.)	Any position other than P or N (When the brake pedal is not depressed, there will be no effect even if the A/T selector lever is in P or N position.)	3
LOCK → START ACC → START ON → START (Engine start)	Depressed	P or N position (*1)	1 [If the switch is pushed once, the engine starts from any power supply position (LOCK, ACC, and ON)]
Engine start condition → LOCK (Engine stop)	—	P position	1
Engine start condition → ACC (Engine stop)	—	Any position other than P (*2)	1
Engine stall return operation while driving	—	N position	1

\*1: When the A/T selector lever position is N position, the engine start condition is different according to the vehicle speed.

- At vehicle speed of 5 km/h or less, the engine can start only when the brake pedal is depressed.
- At vehicle speed of 5 km/h or more, the engine can start even if the brake pedal is not depressed. (It is the same as “Engine stall return operation while driving”.)

\*2: When the A/T selector lever position is any position other than P position and when the vehicle speed is 5 km/h or more, the engine stop condition is different.

- Press and hold the push-button ignition switch for 2 seconds or more. (When the push-button ignition switch is pressed for too short a time, the operation may be invalid, so properly press and hold to prevent the incorrect operation.)
- Press the push-button ignition switch 3 times within 1.5 seconds. (Emergency stop operation)



# PDU (POWER DISTRIBUTION UNIT)

PG-PDU-02

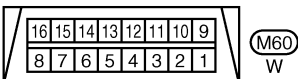
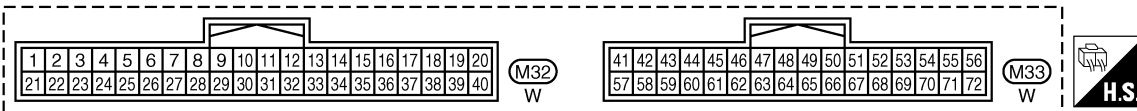
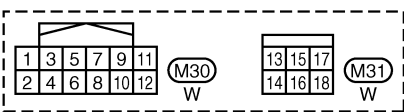
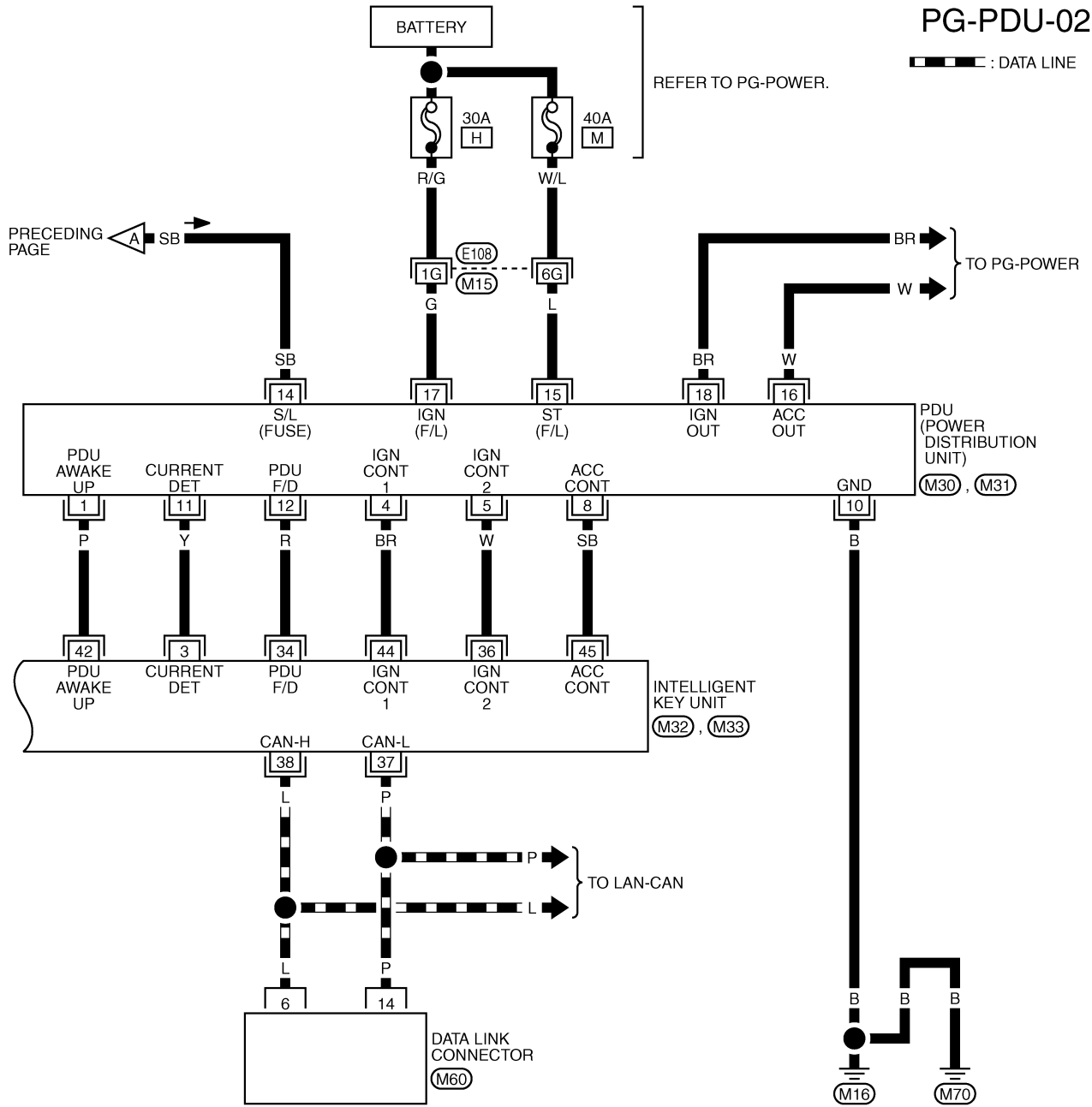

REFER TO THE FOLLOWING.  
E108 -SUPER MULTIPLE JUNCTION (SMJ)

TKWT3321E

# PDU (POWER DISTRIBUTION UNIT)

## Terminals and Reference Value for Intelligent Key Unit

NKS004EG

Terminal	Wire Color	Item	Signal Input/Output	Condition		Voltage (V) Approx.
				Ignition Switch Position	Operation or Conditions	
1	SB	Power source (Fuse)	Input	LOCK	—	Battery voltage
3	Y	IPDM E/R status signal	Output	—	Engine starting (During Cranking)	5
				—	Other than above	2
8	W	Push-button ignition switch (LOCK LED)	Input	LOCK	Push-button ignition switch is in LOCK position	0
				—	Push-button ignition switch is in any position (Except LOCK position)	1.2
9	L	Push-button ignition switch (ACC LED)	Input	ACC	Push-button ignition switch is in ACC position	0
				—	Push-button ignition switch is in any position (Except ACC position)	1.2
10	V	Push-button ignition switch (ON LED)	Input	ON	Push-button ignition switch is in ON position	0
				—	Push-button ignition switch is in any position (Except ON position)	1.2
20	B	Ground	—	—	—	0
30	L/W	Ignition switch (ACC)	Input	ACC	—	Battery voltage
31	GR	Ignition switch (ON)	Input	ON	—	Battery voltage
34	R	PDU feedback signal	Output	LOCK	Push-button ignition switch is in LOCK state, 30 seconds after all doors closed	1
				—	Other than above	0
36	W	Ignition signal 2	Input	LOCK	—	Battery voltage
				ACC	—	Battery voltage
				ON	—	0
37	P	CAN-L	Input/Output	—	—	—
38	L	CAN-H	Input/Output	—	—	—
39	BR/W	Push switch	Input	—	Depress push-button ignition switch	0
				—	Other than above	Battery voltage
40	B	Ground	—	—	—	0
41	Y	Power source (Fuse)	Input	LOCK	—	Battery voltage
42	P	PDU wake up signal	Output	LOCK	Push-button ignition switch is in LOCK state, 30 seconds after all doors closed	Battery voltage
				—	Other than above	0
44	BR	Ignition signal 1	Input	LOCK	—	Battery voltage
				ACC	—	Battery voltage
				ON	—	0
45	SB	ACC signal	Input	LOCK	—	Battery voltage
				ACC	—	0
				ON	—	0
56	B	Ground	—	—	—	0

# PDU (POWER DISTRIBUTION UNIT)

Terminal	Wire Color	Item	Signal Input/Output	Condition		Voltage (V) Approx.
				Ignition Switch Position	Operation or Conditions	
57	L	Power source (Fuse)	Input	LOCK	—	Battery voltage
72	B	Ground	—	—	—	0

## Terminals and Reference Value for PDU

NKS004EH

Terminal	Wire Color	Item	Signal Input/Output	Condition		Voltage (V) Approx.
				Ignition Switch Position	Operation or Conditions	
1	P	PDU wake up signal	Output	LOCK	Push-button ignition switch is in LOCK state, 30 seconds after all doors close	Battery voltage
					Other than above	0
4	BR	Ignition signal 1	Output	LOCK	—	Battery voltage
				ACC	—	Battery voltage
				ON	—	0
5	W	Ignition signal 2	Output	LOCK	—	Battery voltage
				ACC	—	Battery voltage
				ON	—	0
8	SB	ACC signal	Output	LOCK	—	Battery voltage
				ACC	—	0
				ON	—	0
10	B	Ground	—	—	—	0
11	Y	IPDM E/R status signal	Input	—	Engine starting (During Cranking)	5
					Other than above	2
12	R	PDU feedback signal	Input	LOCK	Push-button ignition switch is in LOCK state, 30 seconds after all doors close	1
					Other than above	0
14	SB	Power source (Fuse)	Input	LOCK	—	Battery voltage
15	L	Power source (F/L)	Input	LOCK	—	Battery voltage
16	W	ACC power output	Output	LOCK	—	0
				ACC	—	Battery voltage
				ON	—	Battery voltage
17	G	Power source (Fuse)	Input	LOCK	—	Battery voltage
18	BR	ON power output	Output	LOCK	—	0
				ACC	—	0
				ON	—	Battery voltage

## Work Flow

NKS004EI

1. Check the symptom and customer's requests.
2. Understand outline of system. Refer to [PG-32, "System Description"](#).
3. Confirm that Intelligent Key system operates normally. Refer to [BL-24, "POWER DOOR LOCK SYSTEM"](#).
4. Repair or replace any malfunctioning parts. Refer to [PG-38, "Trouble Diagnosis Symptom Chart"](#).
5. INSPECTION END

# PDU (POWER DISTRIBUTION UNIT)

## Trouble Diagnosis Symptom Chart

NKS004EJ

Before performing the diagnosis in the following table, check the contents of [PG-37, "Work Flow"](#) .

Symptom	Suspect Systems	Refer to
Even if the push-button ignition switch is pressed, the power supply position and the push-button ignition switch position indicator does not response.	1. Check push-button ignition switch (ignition switch) system	<a href="#">PG-39</a>
	2. Replace Intelligent Key unit	<a href="#">BL-123</a>
The push-button ignition switch position indicator turns on synchronizing with the push-button ignition switch operation. But the actual power supply is not input.	1. Check PDU power supply and ground circuit system	<a href="#">PG-39</a>
	2. Check PDU communication circuit system 1	<a href="#">PG-42</a>
	3. Replace PDU	<a href="#">PG-44</a>
The push-button ignition switch position indicator turns on synchronizing with the push-button ignition switch operation. But the actual ON power supply is not input. (ACC power supply input is normal.)	1. Check PDU communication circuit system 2	<a href="#">PG-43</a>
	2. Replace PDU	<a href="#">PG-44</a>
The power supply changing operation is normal. But the push-button ignition switch position indicator does not turn on.	1. Check push-button ignition switch (indicator circuit) system	<a href="#">PG-41</a>
	2. Replace Intelligent Key unit	<a href="#">BL-123</a>

## Check CAN Communication System

NKS004EK

### 1. CHECK SELF-DIAGNOSTIC RESULTS

#### CAUTION:

If CONSULT-II is used with no connection of CONSULT-II CONVERTER, malfunctions might be detected in self-diagnosis depending on control unit which performs CAN communication.

#### With CONSULT-II

- Connect CONSULT-II, and turn ignition switch ON.
- Touch "INTELLIGENT KEY" on "SELECT SYSTEM" screen.
- Touch "SELF-DIAG RESULTS" on "SELECT DIAG MODE" screen.
- Check display content in self-diagnostic results.

CONSULT-II display item	DTC code
NO DTC IS DETECTED	—
CAN COMM CIRCUIT	U1000
CONTROL UNIT (CAN)	U1010

#### OK or NG

NO DTC IS DETECTED>> INSPECTION END

CAN COMM CIRCUIT [U1000]>> After printing "SELF-DIAGNOSIS RESULTS", go to "CAN SYSTEM", Refer to [LAN-42, "Precautions When Using CONSULT-II"](#) .

CONTROL UNIT (CAN) [U1010]>> Replace Intelligent Key unit.

# PDU (POWER DISTRIBUTION UNIT)

NKS004EL

## Check PDU Power Supply and Ground Circuit

### 1. CHECK POWER SUPPLY CIRCUIT

1. Turn ignition switch OFF.
2. Disconnect PDU connector.
3. Check voltage between PDU harness connector and ground.

PDU connector	Terminal		Voltage (V) (Approx.)
	(+)	(-)	
M31	14	Ground	Battery voltage
	15		
	17		

#### OK or NG

- OK >> GO TO 2.  
 NG >> Repair or replace PDU power supply circuit.

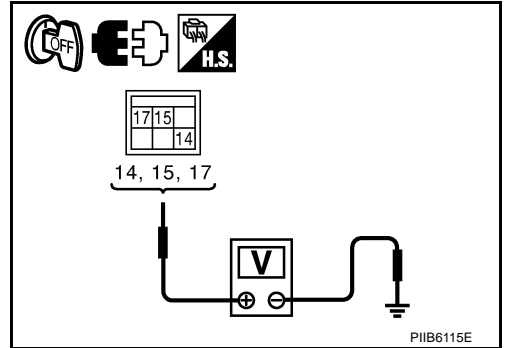

### 2. CHECK GROUND CIRCUIT

Check continuity between PDU harness connector and ground.

PDU connector	Terminal	Continuity
M30	10	Yes

#### OK or NG

- OK >> Power supply and ground circuits are OK.  
 NG >> Repair or replace the PDU ground circuit.

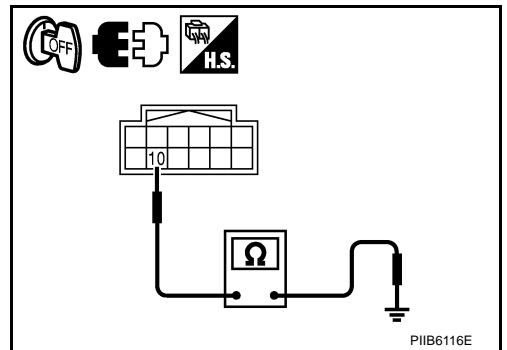

## Check Push-Button Ignition Switch (Ignition Switch) System

NKS004EM

### 1. CHECK PUSH-BUTTON IGNITION SWITCH

1. Turn ignition switch OFF.
2. Disconnect Intelligent Key unit connector.
3. Check continuity between Intelligent Key unit harness connector and ground.

Intelligent Key unit connector	Terminal		Condition	Continuity
M32	39	Ground	Push-button ignition switch is pressed	Yes
			Push-button ignition switch is released	No

#### OK or NG

- OK >> Push-button ignition switch system is OK.  
 NG >> GO TO 2.

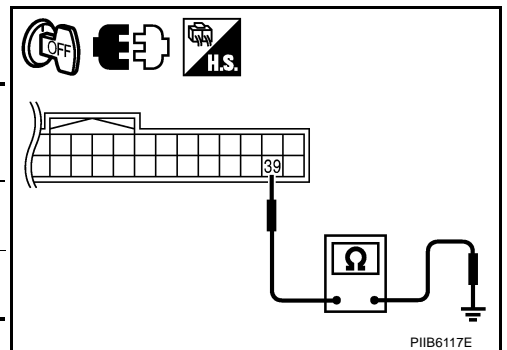

# PDU (POWER DISTRIBUTION UNIT)

## 2. CHECK PUSH-BUTTON IGNITION SWITCH OPERATION

1. Turn ignition switch OFF.
2. Check continuity push-button ignition switch connector.

Push-button ignition switch connector	Terminal		Condition	Continuity
	1	4		
M27	1	4	Push-button ignition switch is pressed	Yes
			Push-button ignition switch is released	No

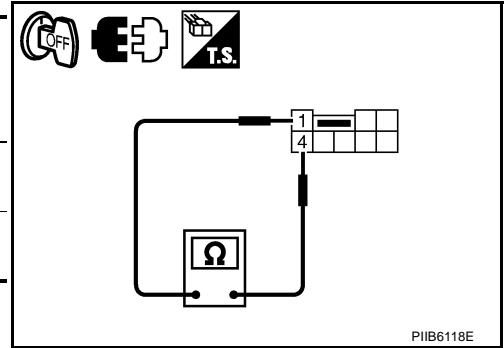

OK or NG

- OK >> GO TO 3.  
 NG >> Replace push-button ignition switch.

## 3. CHECK PUSH-BUTTON IGNITION SWITCH GROUND CIRCUIT SYSTEM

Check continuity between push-button ignition switch harness connector and ground.

Push-button ignition switch connector	Terminal	Continuity
M27	1	Ground part of push-button ignition switch

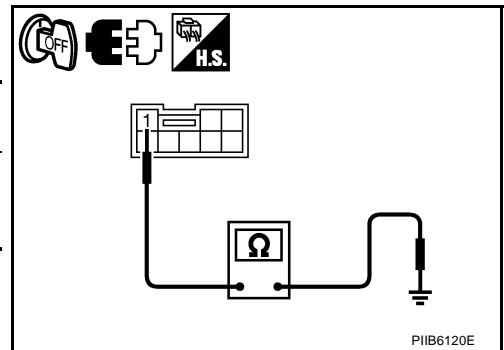

OK or NG

- OK >> GO TO 4.  
 NG >> Repair or replace push-button ignition switch ground circuit.

## 4. CHECK PUSH-BUTTON IGNITION SWITCH CIRCUIT

1. Disconnect Intelligent Key unit connector.
2. Check continuity between Intelligent Key unit harness connector and push-button switch harness connector.

A		B		Continuity
Push-button ignition switch connector	Terminal	Intelligent Key unit connector	Terminal	
M27	4	M32	39	Yes

3. Check continuity between push-button ignition switch harness connector and ground.

Push-button ignition switch connector	Terminal	Continuity
M27	4	Ground

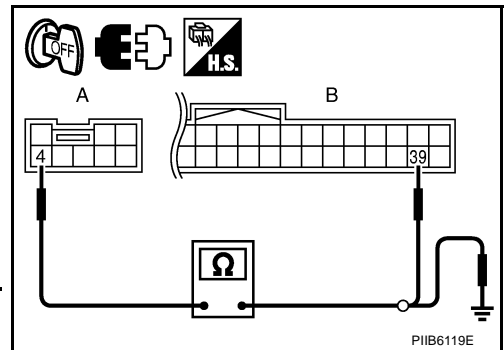

OK or NG

- OK >> GO TO 5.  
 NG >> Repair or replace harness between Intelligent Key unit and ignition switch.



# PDU (POWER DISTRIBUTION UNIT)

## Check Push-Button Ignition Switch (Indicator Circuit) System

NKS004EN

### 1. CHECK PUSH-BUTTON IGNITION SWITCH INDICATOR SYSTEM

1. Turn ignition switch OFF.
2. Check voltage between Intelligent Key unit connector and ground.

Intelligent Key unit connector	Terminal		Push-button ignition switch condition	Voltage (V) (Approx)
	(+)	(-)		
M32	8	Ground part of push-button ignition switch	LOCK position	0
			Except LOCK position	1.2
	9		ACC position	0
			Except ACC position	1.2
	10		ON position	0
			Except ON position	1.2

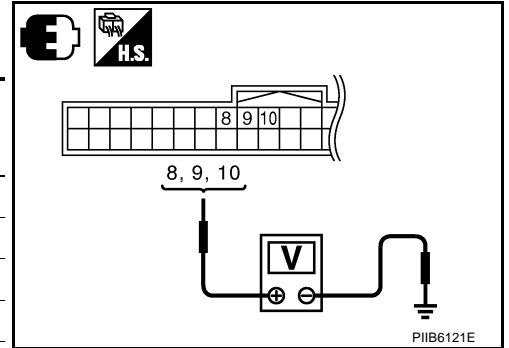

OK or NG

- OK >> GO TO 2.  
 NG >> Repair or replace push-button ignition switch.

### 2. PUSH-BUTTON IGNITION SWITCH INDICATOR POWER SUPPLY SIGNAL

1. Turn ignition switch OFF.
2. Disconnect push-button ignition switch.
3. Check voltage between push-button ignition switch connector and ground.

Push-button ignition switch connector	Terminal		Voltage (V) (Approx)
	(+)	(-)	
M27	8	Ground	Battery voltage

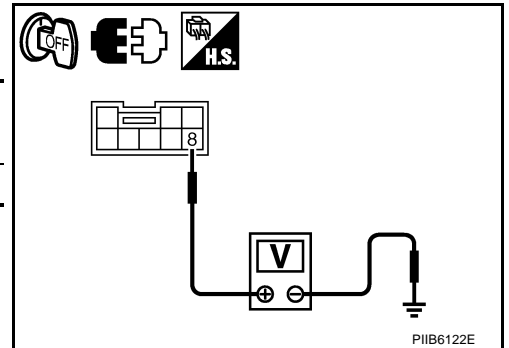

OK or NG

- OK >> GO TO 3.  
 NG >> Repair or replace push-button ignition switch.

A  
B  
C  
D  
E  
F  
G  
H  
I  
J  
PG  
L  
M

# PDU (POWER DISTRIBUTION UNIT)

## 3. PUSH-BUTTON IGNITION SWITCH INDICATOR GROUND CIRCUIT

1. Disconnect Intelligent Key unit connector.
2. Check continuity between Intelligent Key unit connector and push-button ignition switch connector.

A		B		Continuity
Intelligent Key unit connector	Terminal	Push-button ignition switch connector	Terminal	
M32	8	M27	5	Yes
	9		6	
	10		7	

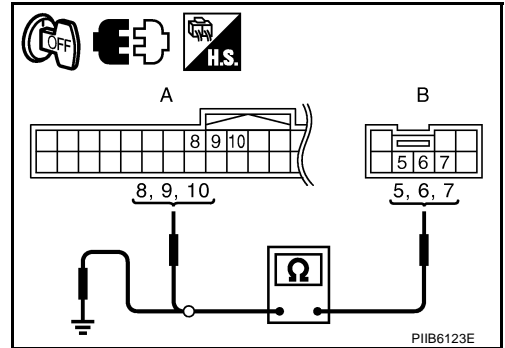

3. Check continuity between push-button ignition switch connector.

Push-button ignition switch connector	Terminal	Continuity
M27	5	Ground
	6	
	7	

**OK or NG**

- OK >> Check harness condition.  
 NG >> Repair or replace harness.

## PDU Communication Circuit System 1

NKS004EO

### 1. CHECK PDU COMMUNICATION CIRCUIT 1

1. Turn ignition switch OFF.
2. Check voltage between Intelligent Key unit connector and ground.

Intelligent Key unit connector	Terminal	Condition	Voltage (V) (Approx)	
M33	42	Ground	0	
		Driver side door is opened (PDU wake up mode)	0	
	45	Ground	Push-button ignition switch is in lock state, 30 seconds after all doors are closed (PDU sleep mode)	Battery voltage
		Ground	Push-button ignition switch is in LOCK position	Battery voltage
		Ground	Push-button ignition switch is in ACC position	0
		Ground	Push-button ignition switch is in ON position	0

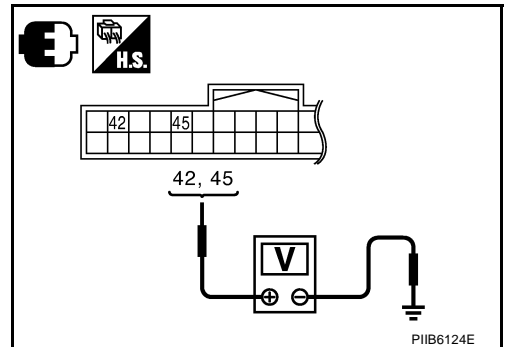

**OK or NG**

- OK >> Check harness condition.  
 NG >> GO TO 2.

# PDU (POWER DISTRIBUTION UNIT)

## 2. CHECK PDU SIGNAL CIRCUIT

1. Disconnect Intelligent Key unit, PDU connector.
2. Check continuity between Intelligent Key unit connector and PDU harness side connector.

A		B		Continuity
PDU connector	Terminal	Intelligent Key unit connector	Terminal	
M30	1	M33	42	Yes
	8		45	

3. Check continuity between PDU connector and ground.

PDU connector	Terminal	Continuity
M30	1	No
	8	

OK or NG

- OK >> Replace Intelligent Key.
- NG >> Check harness condition between Intelligent Key unit and PDU.

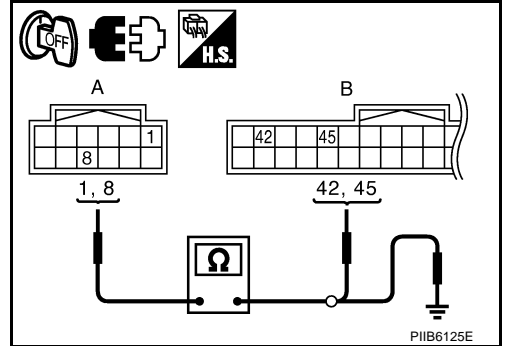

## PDU Communication Circuit System 2

NKS004EP

### 1. CHECK PDU COMMUNICATION CIRCUIT 2

1. Turn ignition switch OFF.
2. Check voltage between Intelligent Key unit connector while operating push-button ignition switch.

Intelligent Key unit connector	Terminal		Push-button ignition switch position	Voltage (V) (Approx)
	(+)	(-)		
M33	44	Ground part of push-button ignition switch	LOCK position	12
			ACC position	12
			ON position	0

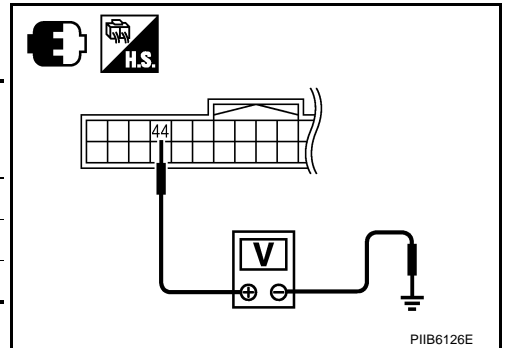

OK or NG

- OK >> Check connector condition.
- NG >> GO TO 2.

## 2. CHECK PDU SIGNAL CIRCUIT

1. Disconnect Intelligent Key unit, PDU connectors.
2. Check continuity between Intelligent Key unit connector and PDU connector.

A		B		Continuity
PDU connector	Terminal	Intelligent Key unit connector	Terminal	
M30	4	M33	44	Yes

3. Check continuity between PDU connector and ground.

PDU connector	Terminal	Continuity
M30	4	No

OK or NG

- OK >> Replace Intelligent Key unit.
- NG >> Repair or replace harness between Intelligent Key unit or PDU.

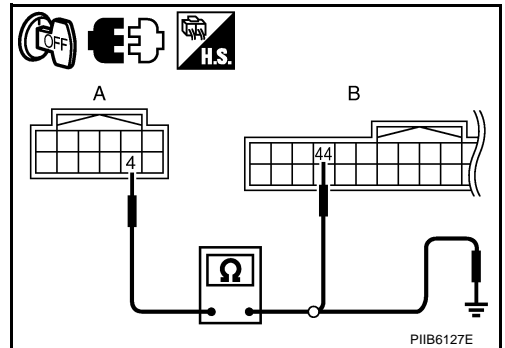

# PDU (POWER DISTRIBUTION UNIT)

## Removal and Installation of PDU

NKS004EQ

### REMOVAL

1. Remove the combination meter. Refer to [DI-27, "Removal and Installation of Combination Meter"](#) .
2. Disconnect PDU unit connector, remove screw and PDU.

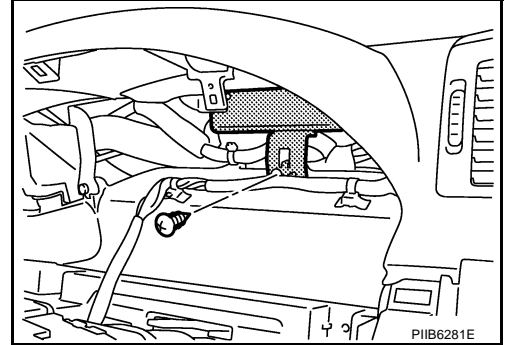

### INSTALLATION

Installation is in the reverse order of removal.

# GROUND

## GROUND

PFP:00011

### Ground Distribution MAIN HARNESS

NKS004ER

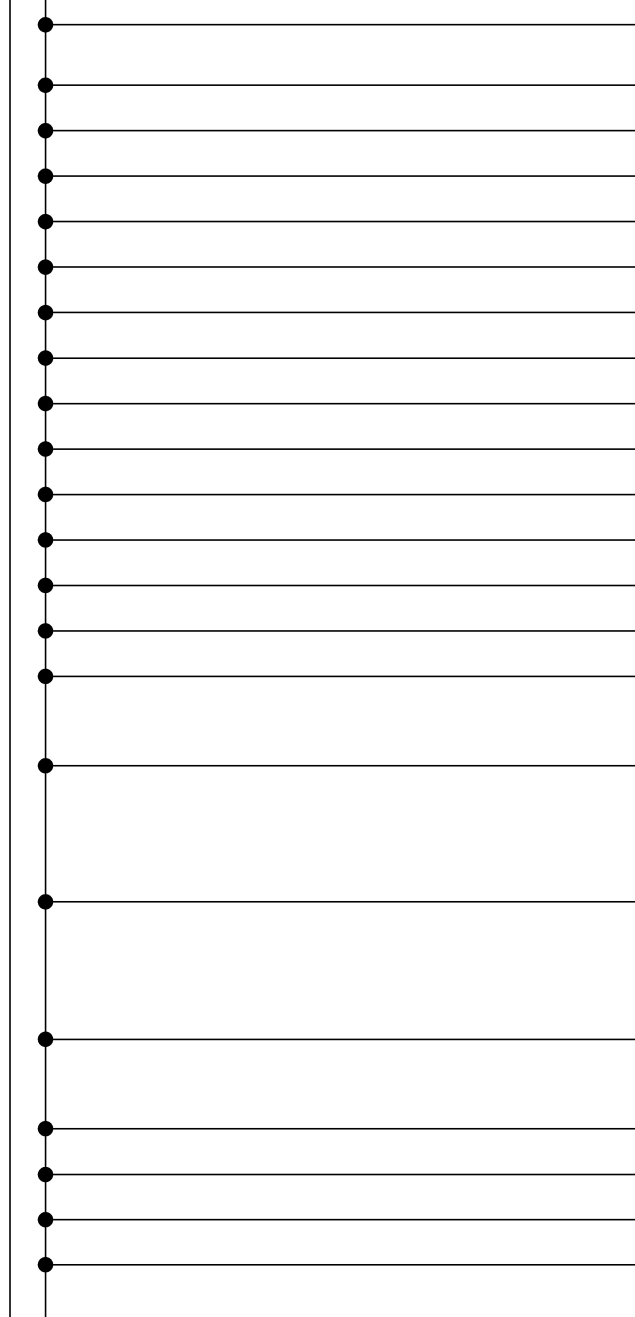
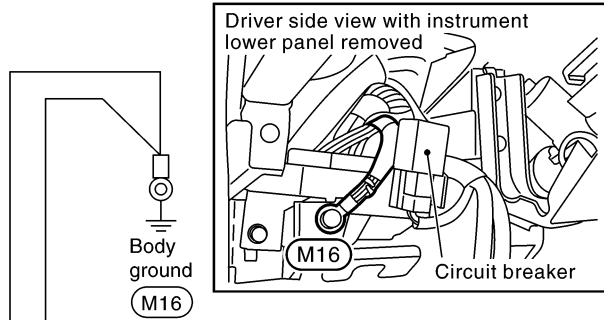

CON-NECTOR NUMBER	CONNECT TO
M5	Fuse block (J/B) • Accessory relay • Blower relay
M8	Power steering control unit
M19	Low tire pressure warning control unit
M24	VDC off switch
M27	Push-button ignition switch
M29	Combination switch
M30	PDU (Power distribution unit)
M32	Intelligent Key unit (Terminal No. 20)
M32	Intelligent Key unit (Terminal No. 40)
M33	Intelligent Key unit (Terminal No. 56)
M33	Intelligent Key unit (Terminal No. 72)
M35	Steering lock unit (Terminal No. 5)
M35	Steering lock unit (Terminal No. 6)
M43	Illumination control switch
M47	Steering angle sensor
M52	Combination meter (Terminal No. 9) • Air bag warning lamp • Meter illumination control switch • Odo/trip meter switch • Unified meter control unit
M52	Combination meter (Terminal No. 10) • Air bag warning lamp • Meter illumination control switch • Odo/trip meter switch • Unified meter control unit
M52	Combination meter (Terminal No. 11) • Air bag warning lamp • Meter illumination control switch • Odo/trip meter switch • Unified meter control unit
M60	Data link connector (Terminal No. 4)
M60	Data link connector (Terminal No. 5)
M63	Clock
M69	Multifunction switch

A B Next page

A  
B  
C  
D  
E  
F  
G  
H  
I  
J  
PG  
L  
M

PG

CKIT0666E

# GROUND

▲ A B Preceding page

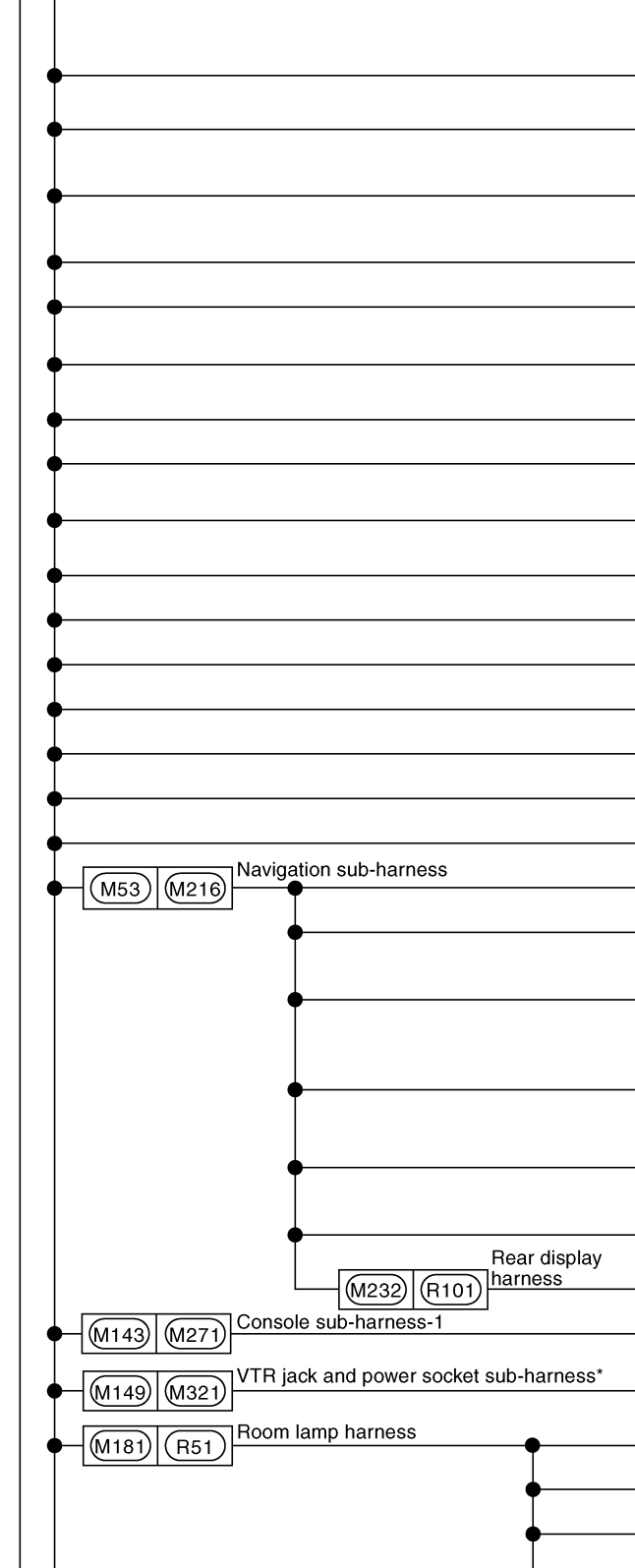

▼ C D Next page

CON-NECTOR NUMBER	CONNECT TO
(M83)	Shield wire [Inside key antenna (Instrument center)]
(M91)	Blower motor
(M95)	Door mirror remote control switch (Terminal No. 13) • Changeover switch • Mirror switch
(M99)	Trunk lid opener cancel switch (Terminal No. 3)
(M132)	Cigarette lighter socket
(M133)	A/T device (Terminal No. 4) • Mode select switch
(M135)	Snow mode switch
(M137)	Rear sunshade front switch
(M140)	Power socket (Floor console inside) (Without DVD player)
(M142)	Shield wire [Inside key antenna (Console)]
(M147)	Air bag diagnosis sensor unit
(M182)	LDW camera unit (Terminal No. 6)
(M182)	LDW camera unit (Terminal No. 12)
(M183)	Vanity mirror lamp LH
(M187)	Auto anti-dazzling inside mirror
(M188)	Vanity mirror lamp RH
(M203)	Front display unit
(M208)	Video distributor
(M210)	Shield wire (NAVI control unit) (With BOSE system and navigation system) (For circuit from terminal No.69,70)
(M210)	Shield wire (AV control unit) (With BOSE system without navigation system) (For circuit from terminal No.69,70)
(M210)	Shield wire (NAVI control unit) (With navigation system)
(M210)	Shield wire (AV control unit) (Without navigation system)
(R103)	Headphone amp.
(M272)	DVD player (Terminal No. 17)
(M323)	Power socket (Floor console rear) (With DVD player)
(R54)	Map lamp (Terminal No. 1)
(R54)	Map lamp (Terminal No. 4)
(R55)	Personal lamp RH
(R57)	Personal lamp LH

\* : This sub-harness is not shown in "HARNESS LAYOUT".

CKIT0828E

# GROUND

△ C D Preceding page

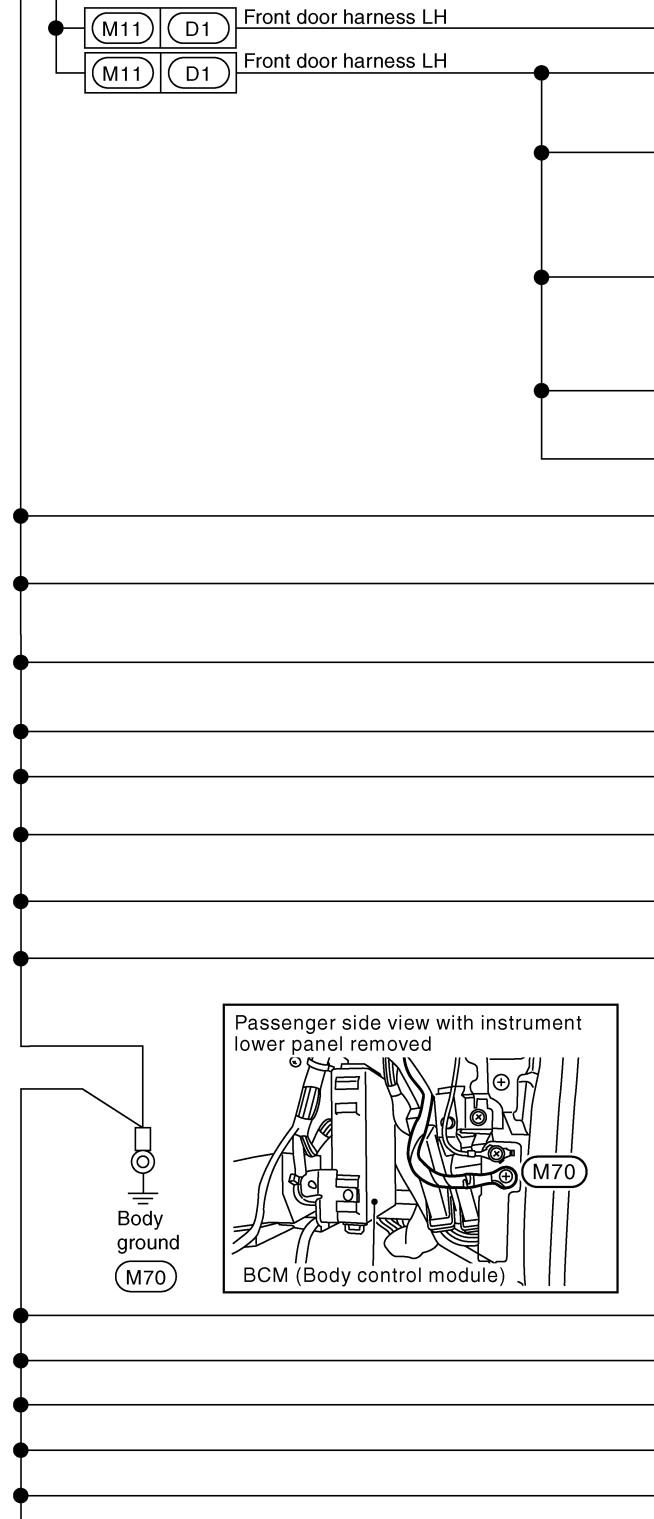

CON-NECTOR NUMBER	CONNECT TO
(D2)	Door mirror LH
(D6)	Power window main switch illumination
(D9)	Seat memory switch • Memory switch-1 • Memory switch-2 • Set switch
(D11)	Power window main switch • CPU • Door lock and unlock switch • Illumination • Power window lock switch
(D14)	Front door lock assembly (Driver side) • Key cylinder switch • Unlock sensor
(D15)	Front outside handle LH
(M7)	Automatic drive positioner control unit (Terminal No. 40)
(M7)	Automatic drive positioner control unit (Terminal No. 48)
(M46)	ADP steering switch • Telescopic switch • Tilt switch
(M49)	LDW switch
(M58)	LDW chime
(M76)	Shield wire (Audio unit) (For circuit from terminal No. 2,3)
(M76)	Shield wire (Audio unit) (For circuit from terminal No. 11,12)
(M186)	Sunroof motor assembly

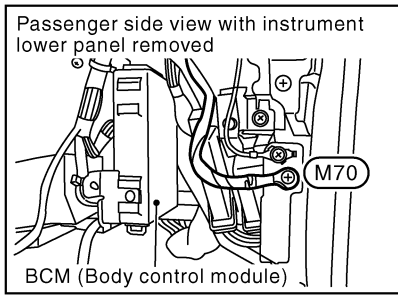

CON-NECTOR NUMBER	CONNECT TO
(M2)	BCM (Body control module)
(M14)	Key slot
(M34)	Diode
(M65)	Unified meter and A/C amp. (Terminal No. 55)
(M65)	Unified meter and A/C amp. (Terminal No. 71)

▽ E Next page

A  
B  
C  
D  
E  
F  
G  
H  
I  
J  
PG  
L  
M

CKIT0829E

# GROUND

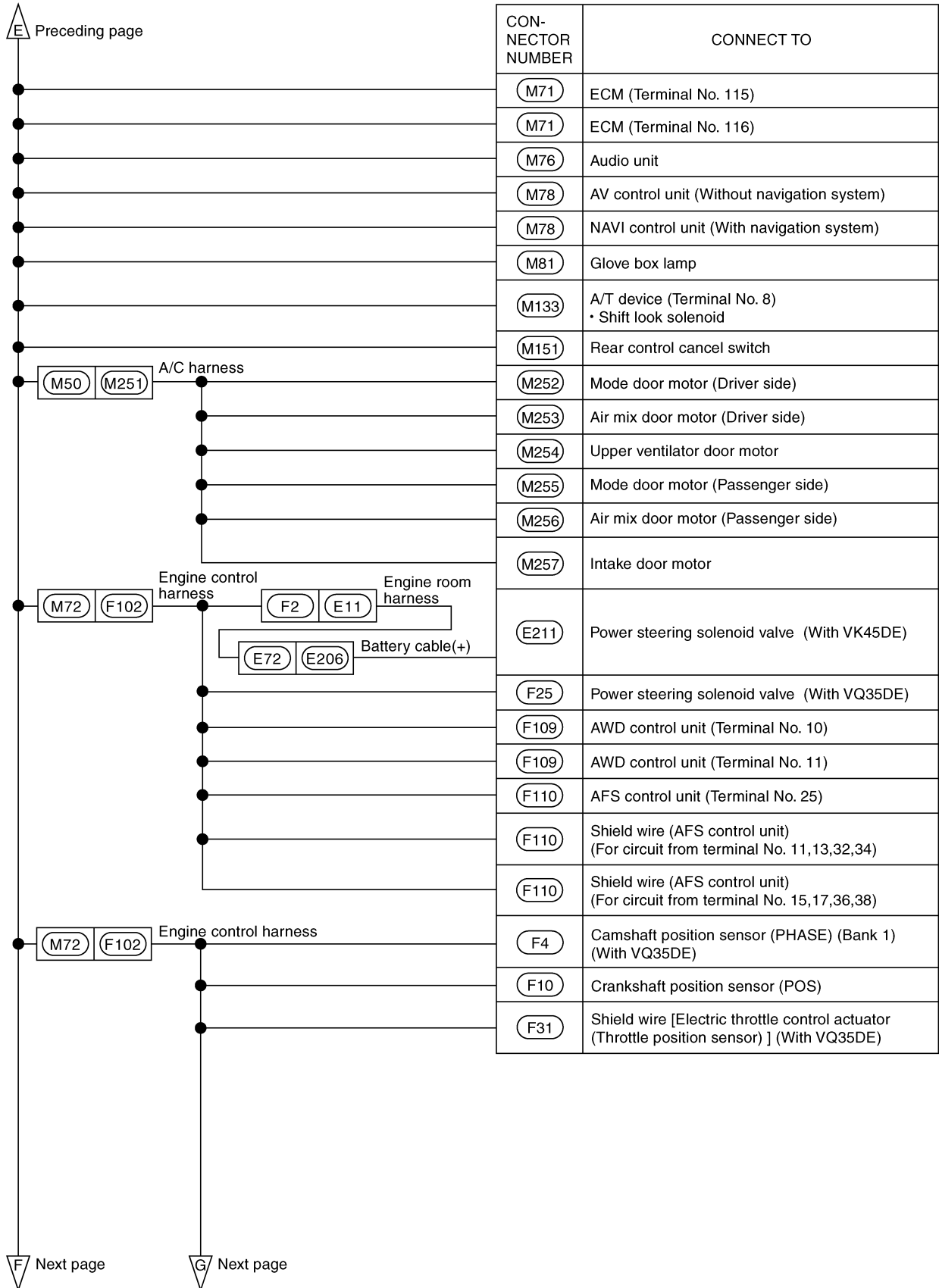

CKIT0830E



# GROUND

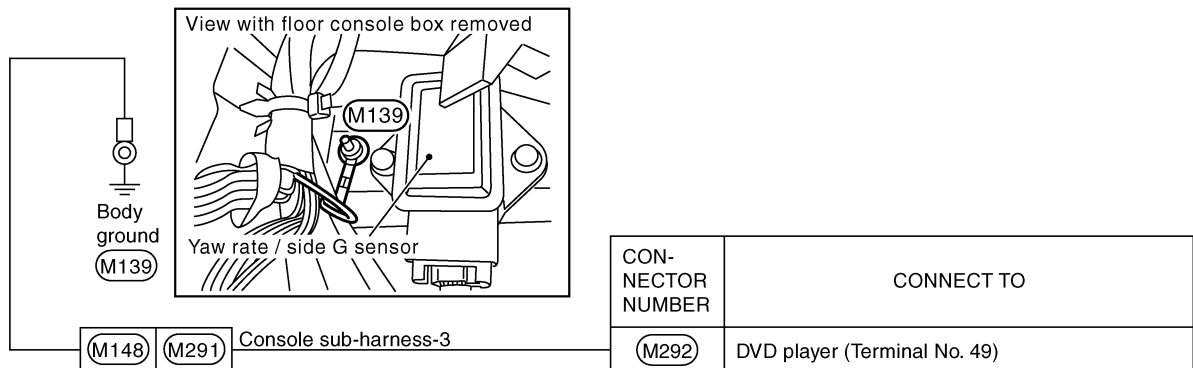
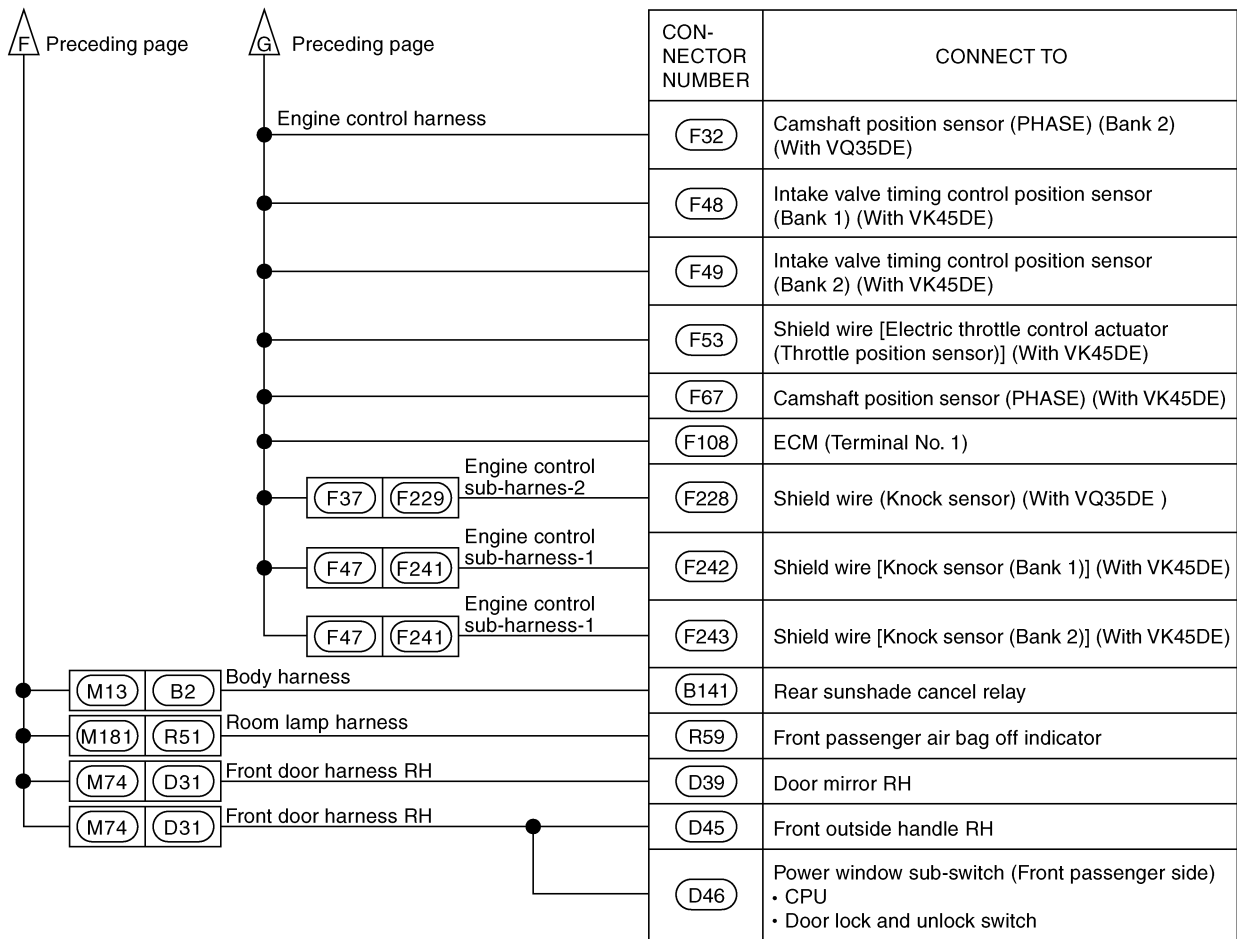

CKIT0831E

# GROUND

## ENGINE ROOM HARNESS

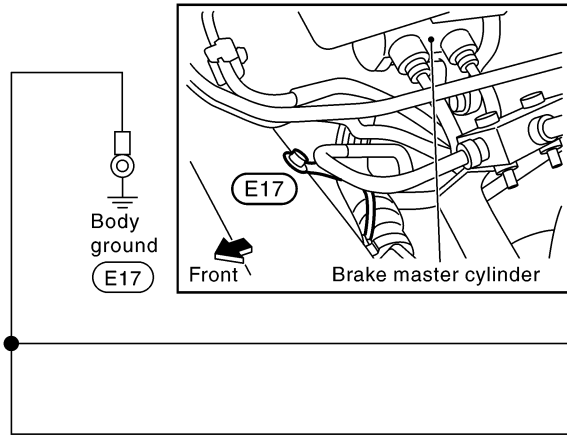

CON-NECTOR NUMBER	CONNECT TO
E30	ABS actuator and electric unit (Control unit) (Terminal No. 1) • Motor
E30	ABS actuator and electric unit (Control unit) (Terminal No.4) • VDC/TCS/ABS control unit

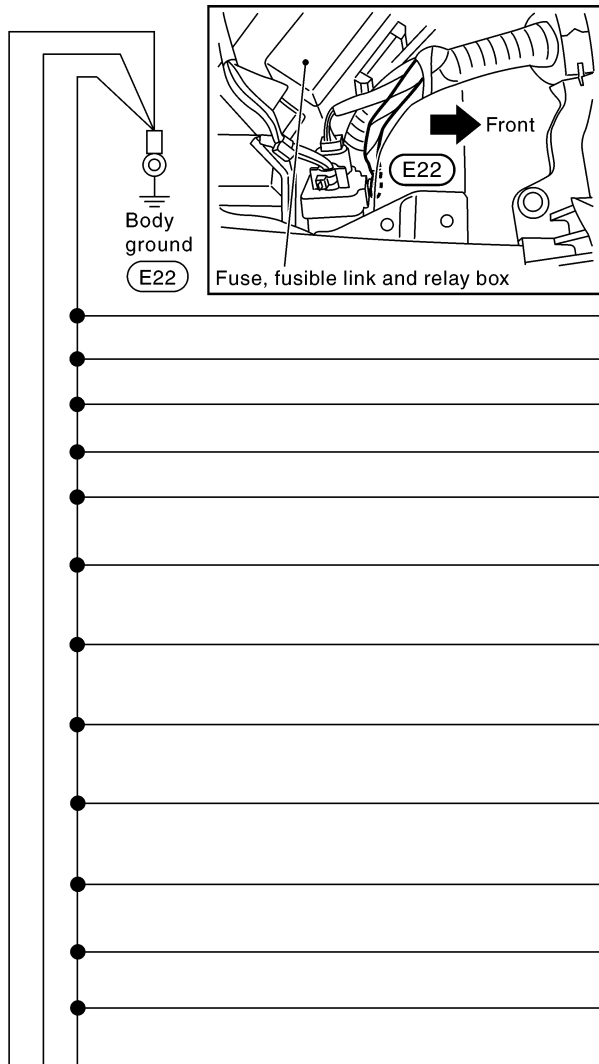

CON-NECTOR NUMBER	CONNECT TO
E16	Climate controlled seat relay
E27	Front wiper motor
E28	Side turn signal lamp RH
E33	Front wiper reverse relay
E42	Cooling fan control module
E47	Front combination lamp RH (With xenon headlamp)(Terminal No. 4) • Headlamp low
E49	Front combination lamp RH (Terminal No. 9) • Turn signal
E54	Front combination lamp LH (Terminal No. 1) • Side marker • Parking
E54	Front combination lamp LH (Terminal No. 2) • Headlamp high
E54	Front combination lamp LH (With halogen headlamp)(Terminal No. 4) • Headlamp low
E60	Front fog lamp LH
E70	Front combination lamp RH (Terminal No. 11) • Aiming motor
E79	Washer level sensor

H/J Next page

CKIT0671E

# GROUND

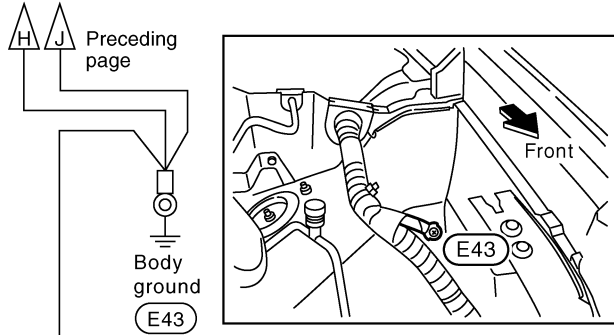

CON-NECTOR NUMBER	CONNECT TO
(E8)	IPDM E/R (Intelligent power distribution module engine room) (Terminal No. 38) • CPU • Front wiper low relay • Ignition relay
(E9)	IPDM E/R (Intelligent power distribution module engine room)(Terminal No. 51) • CPU
(E9)	IPDM E/R (Intelligent power distribution module engine room) (Terminal No. 54) • Heated seat relay
(E23)	Brake fluid level switch
(E34)	Daytime light relay
(E44)	Hood switch
(E45)	Front fog lamp RH
(E47)	Front combination lamp RH (Terminal No. 1) • Side marker • Parking
(E47)	Front combination lamp RH (For U.S.A.) (Terminal No. 2) • Headlamp high
(E47)	Front combination lamp RH (With halogen headlamp) (Terminal No. 4) • Headlamp low
(E54)	Front combination lamp LH (With xenon headlamp)(Terminal No. 4) • Headlamp low
(E55)	Front combination lamp LH (Terminal No. 9) • Turn signal
(E57)	Horn (Low)
(E61)	ICC sensor integrated unit
(E65)	Horn (High)
(E68)	Side turn signal lamp LH
(E71)	Front combination lamp LH (Terminal No. 11) • Aiming motor
(E78)	Resistor
(E80)	ICC brake hold relay
(B142)	Shield wire (Pre-crash seat belt control unit ) (For circuit from terminal No. 2)

(E106) (B4) Body harness

A  
B  
C  
D  
E  
F  
G  
H  
I  
J  
PG  
L  
M

CKIT0837E

# GROUND

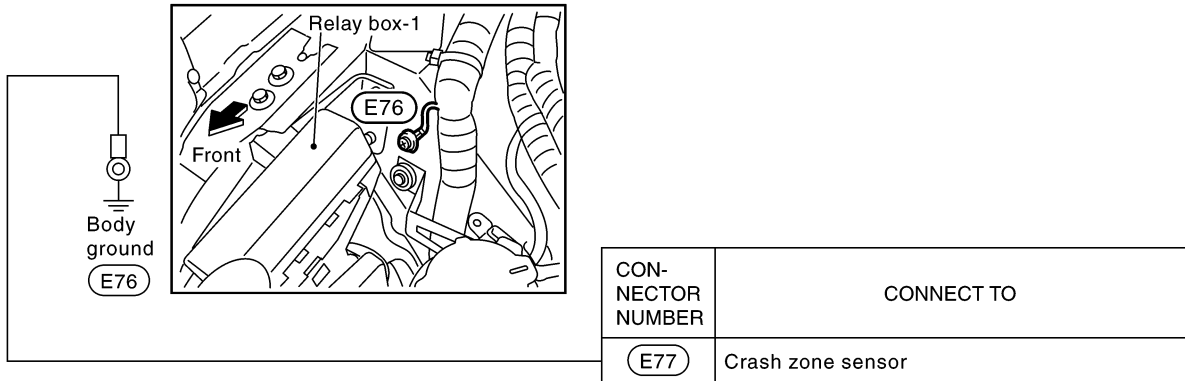

CKIT0673E

# GROUND

## Battery Cable

VQ35DE

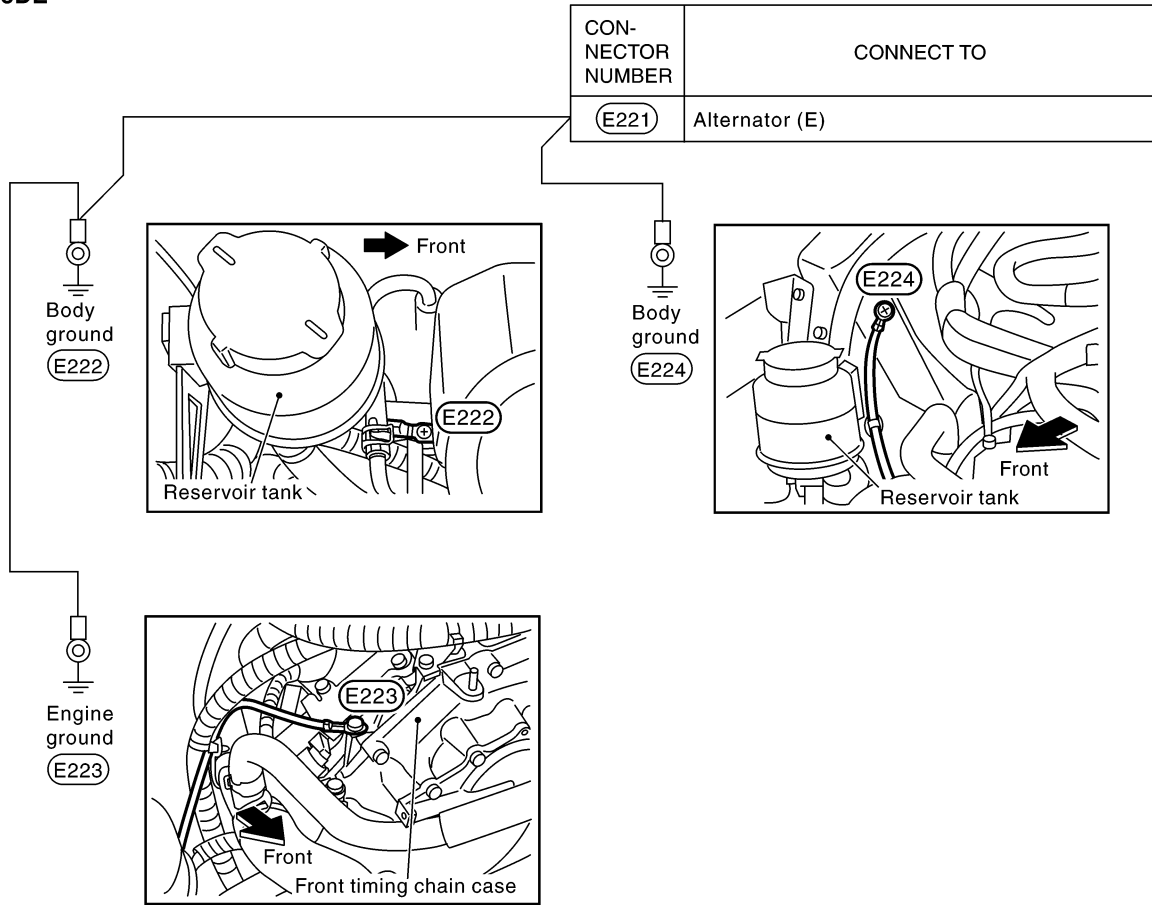

VK45DE

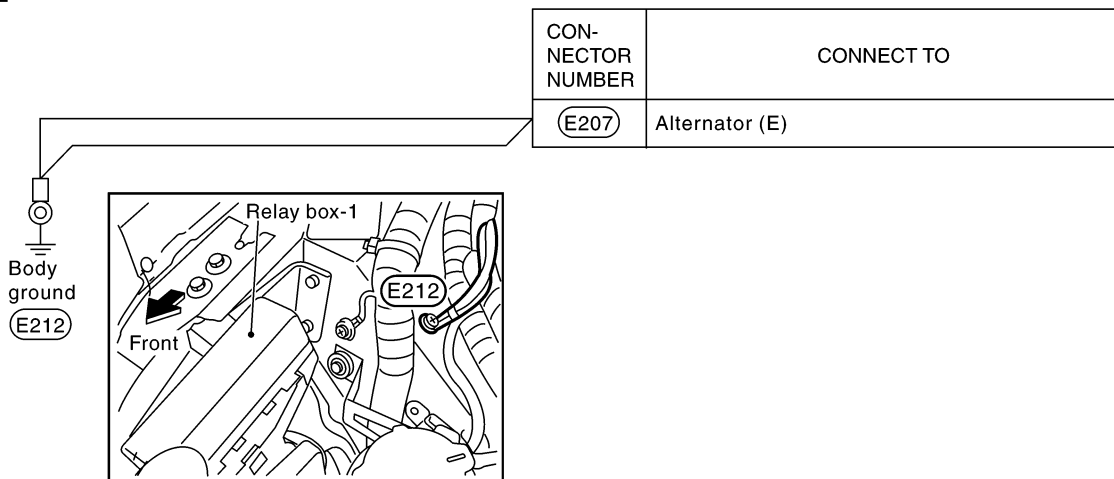

CKIT0674E

A  
B  
C  
D  
E  
F  
G  
H  
I  
J  
PG  
L  
M

# GROUND

## ENGINE CONTROL HARNESS/VQ ENGINE MODELS

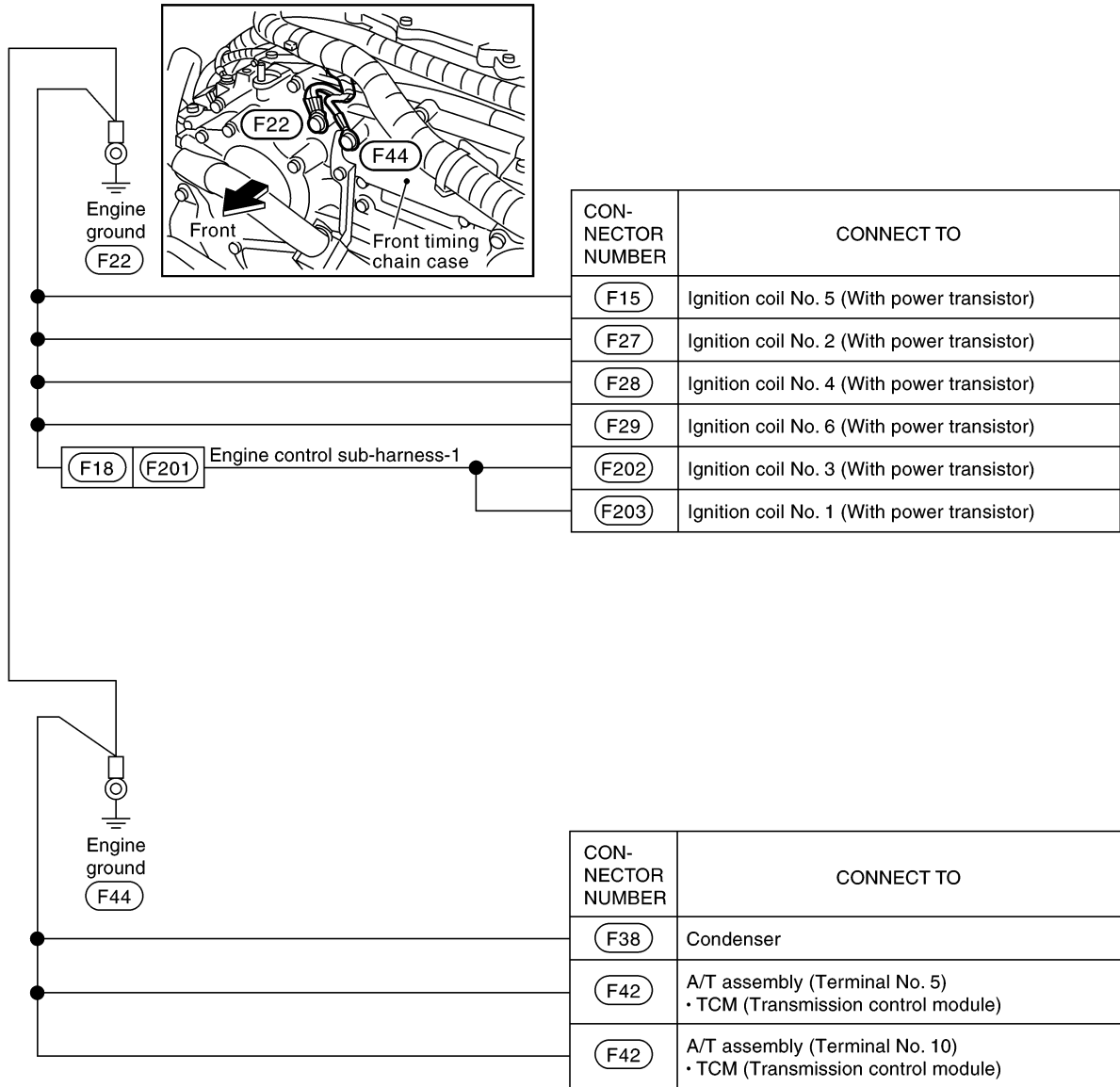

CKIT0675E

# GROUND

## ENGINE CONTROL HARNESS/VK ENGINE MODELS

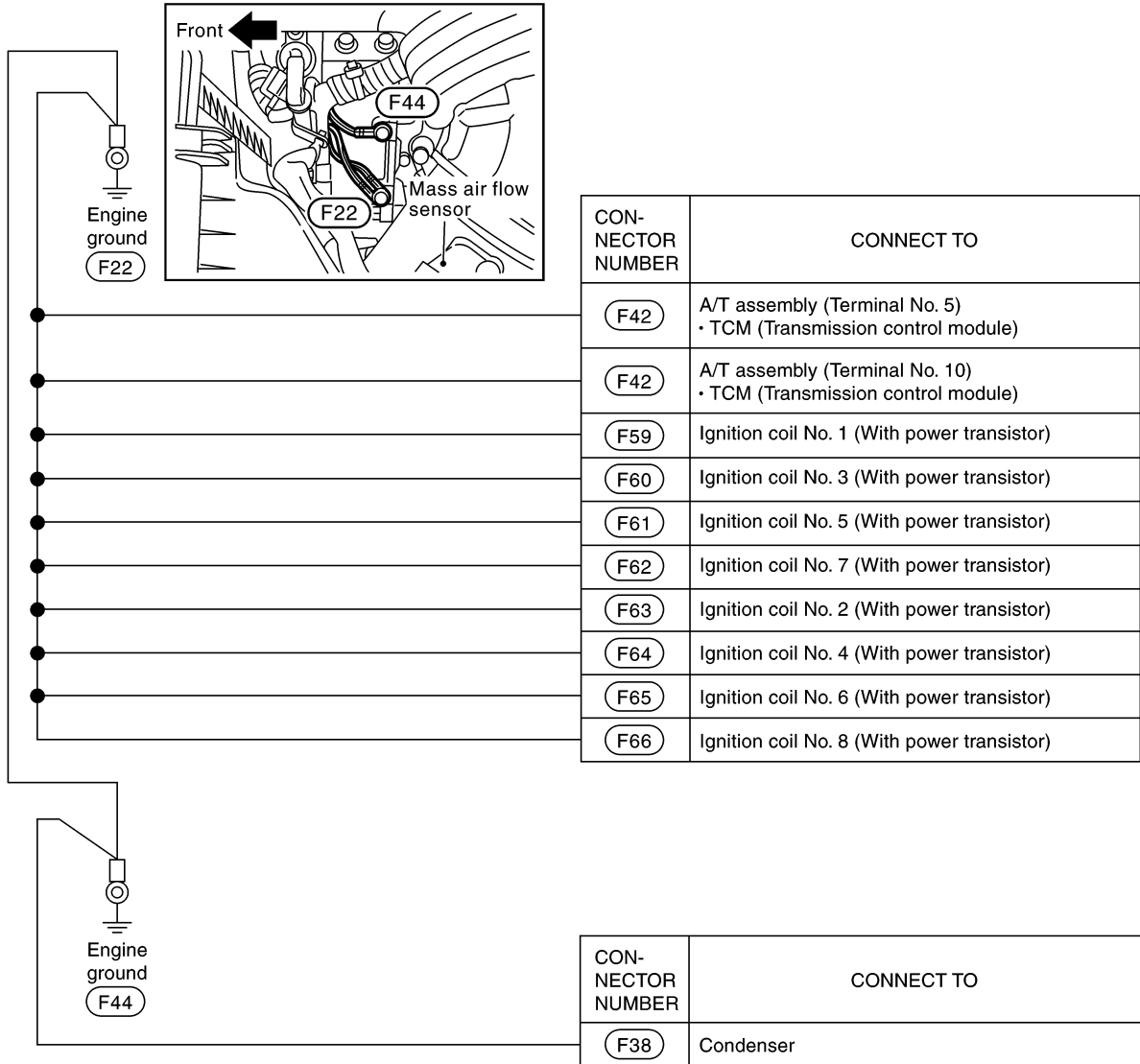

A  
B  
C  
D  
E  
F  
G  
H  
I  
J  
PG  
L  
M

CKIT0676E

# GROUND

## BODY HARNESS

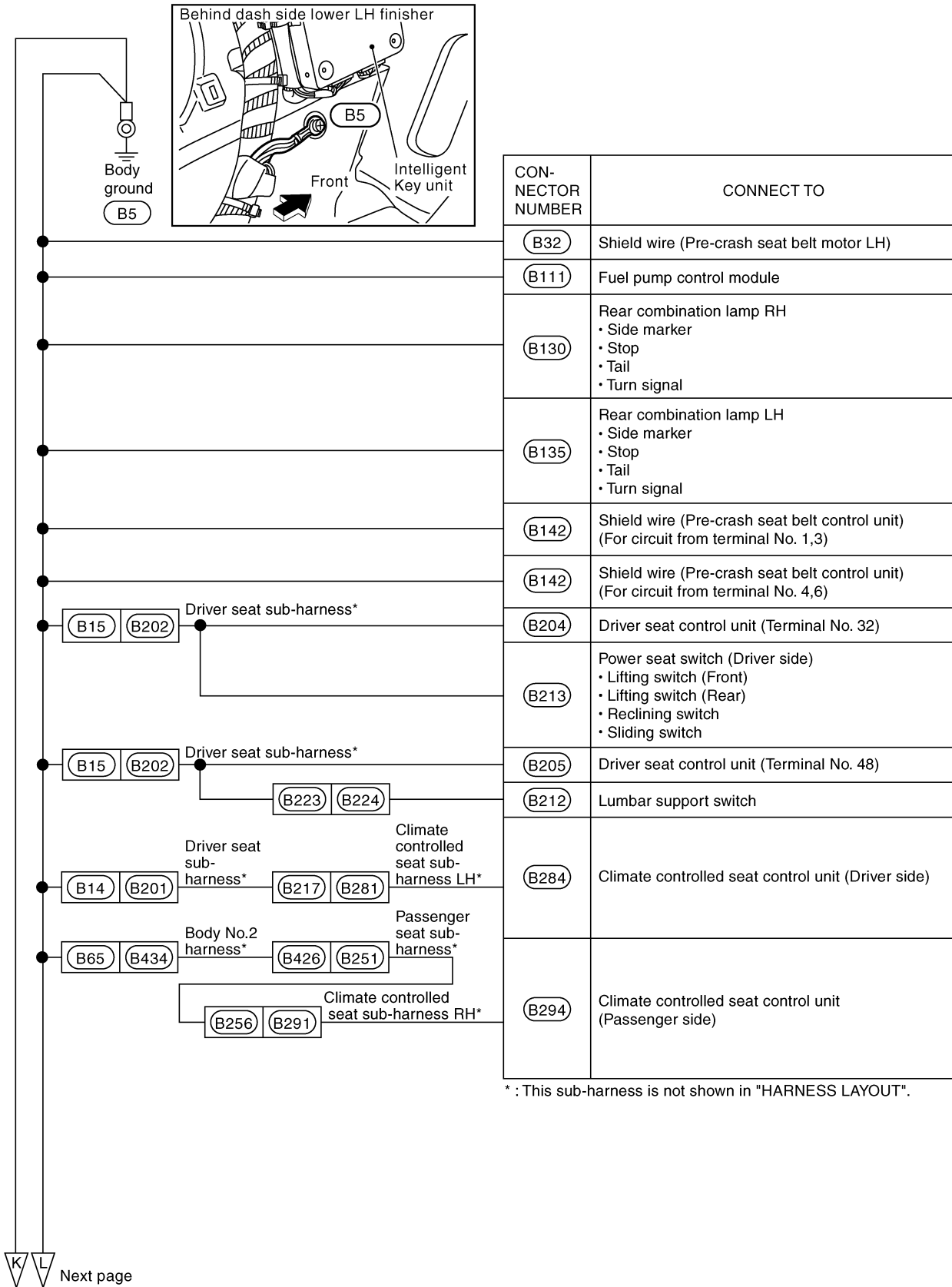

Next page

CKIT0832E



# GROUND

Preceding page

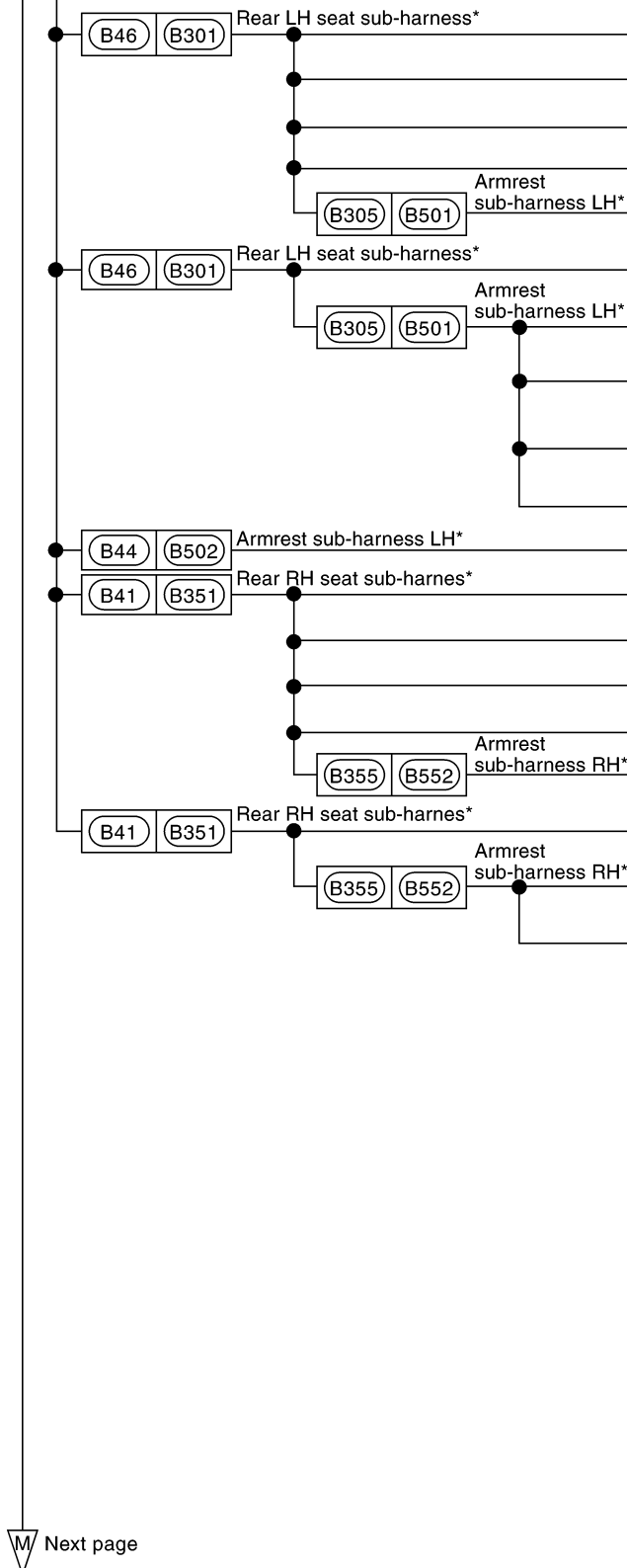

CON-NECTOR NUMBER	CONNECT TO
(B308)	Condenser
(B303)	Rear LH seat control unit (Terminal No. 8)
(B310)	Rear seatback heater LH
(B311)	Rear LH seat sliding motor
(B507)	Rear heated seat switch LH (Terminal No. 3)
(B304)	Rear LH seat control unit (Terminal No. 13)
(B504)	Rear power seat switch LH
(B507)	Rear heated seat switch LH (Terminal No. 8) • Illumination
(B508)	Automatic return cancel switch (Terminal No. 2) • Illumination
(B508)	Automatic return cancel switch (Terminal No. 3)
(B505)	Shield wire (Rear control switch) (Terminal No. 5,7)
(B353)	Rear RH seat control unit (Terminal No. 8)
(B358)	Condenser
(B360)	Rear seatback heater RH
(B361)	Rear RH seat sliding motor
(B558)	Rear heated seat switch RH (Terminal No. 3)
(B354)	Rear RH seat control unit (Terminal No. 13)
(B555)	Rear power seat switch RH
(B558)	Rear heated seat switch RH (Terminal No. 8) • Illumination

\* : This sub-harness is not shown in "HARNES LAYOUT".

Next page

A  
B  
C  
D  
E  
F  
G  
H  
I  
J  
PG  
L  
M

CKIT0678E

# GROUND

▲ Preceding page

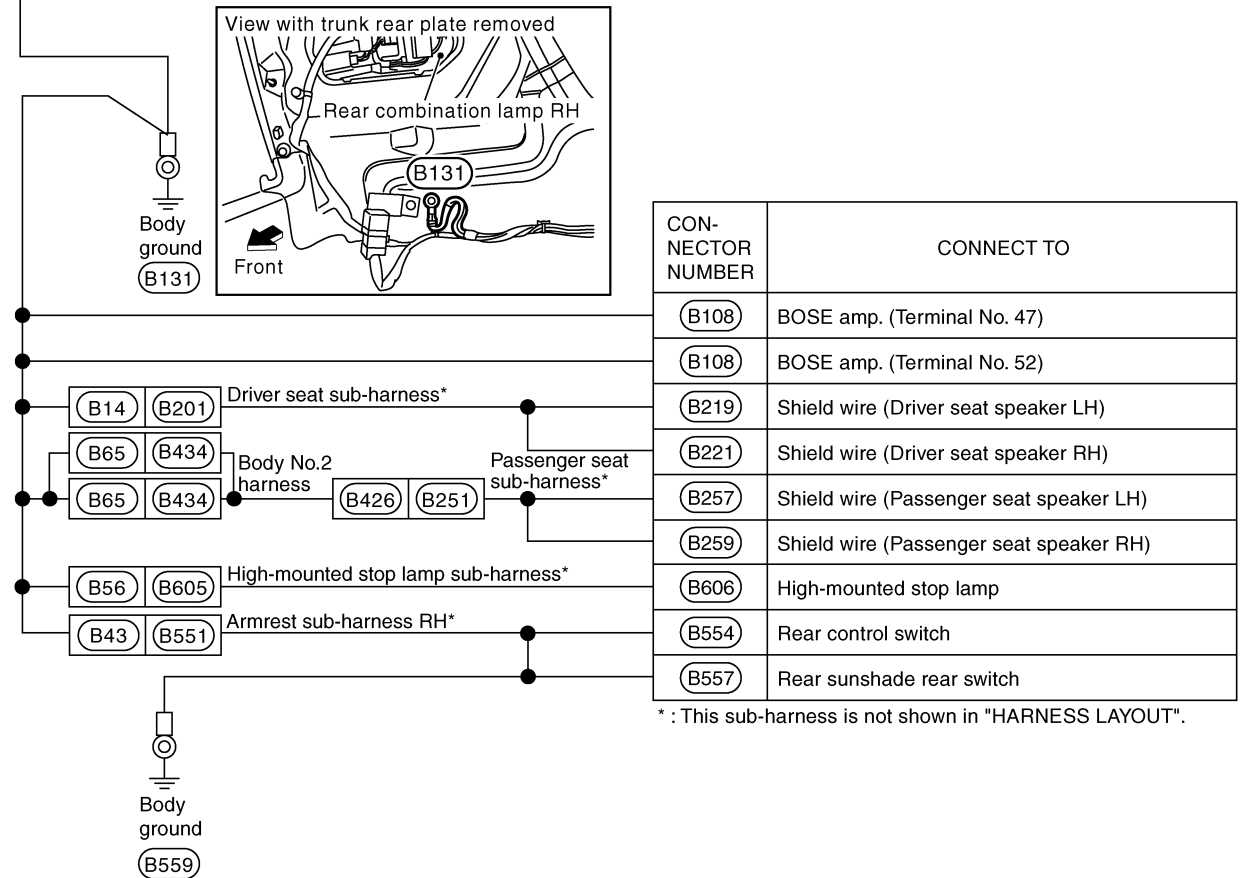
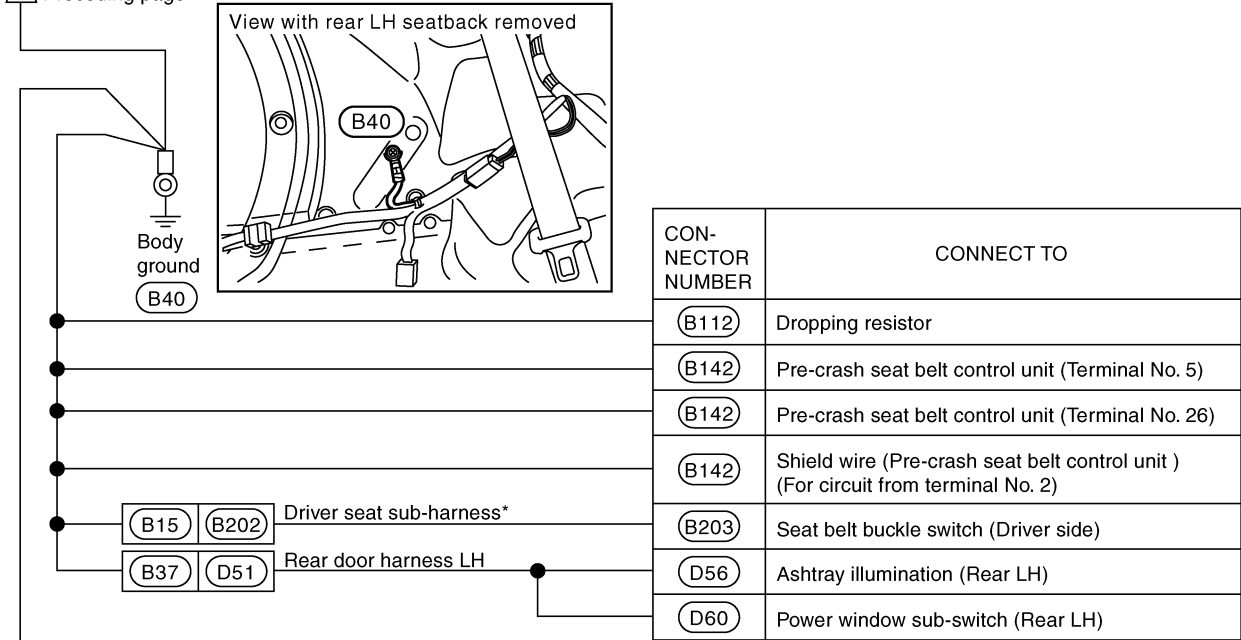

\* : This sub-harness is not shown in "HARNES LAYOUT".

CKIT0833E

# GROUND

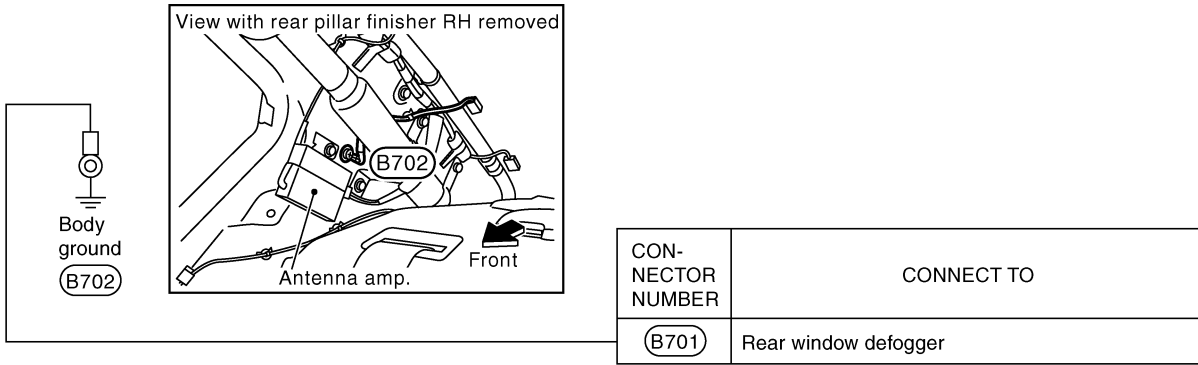
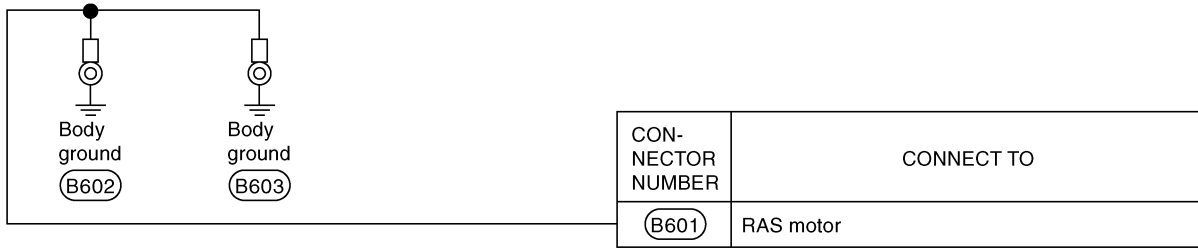

A  
B  
C  
D  
E  
F  
G  
H  
I  
J  
PG  
L  
M

PG

CKIT0834E

# GROUND

## BODY NO. 2 HARNESS

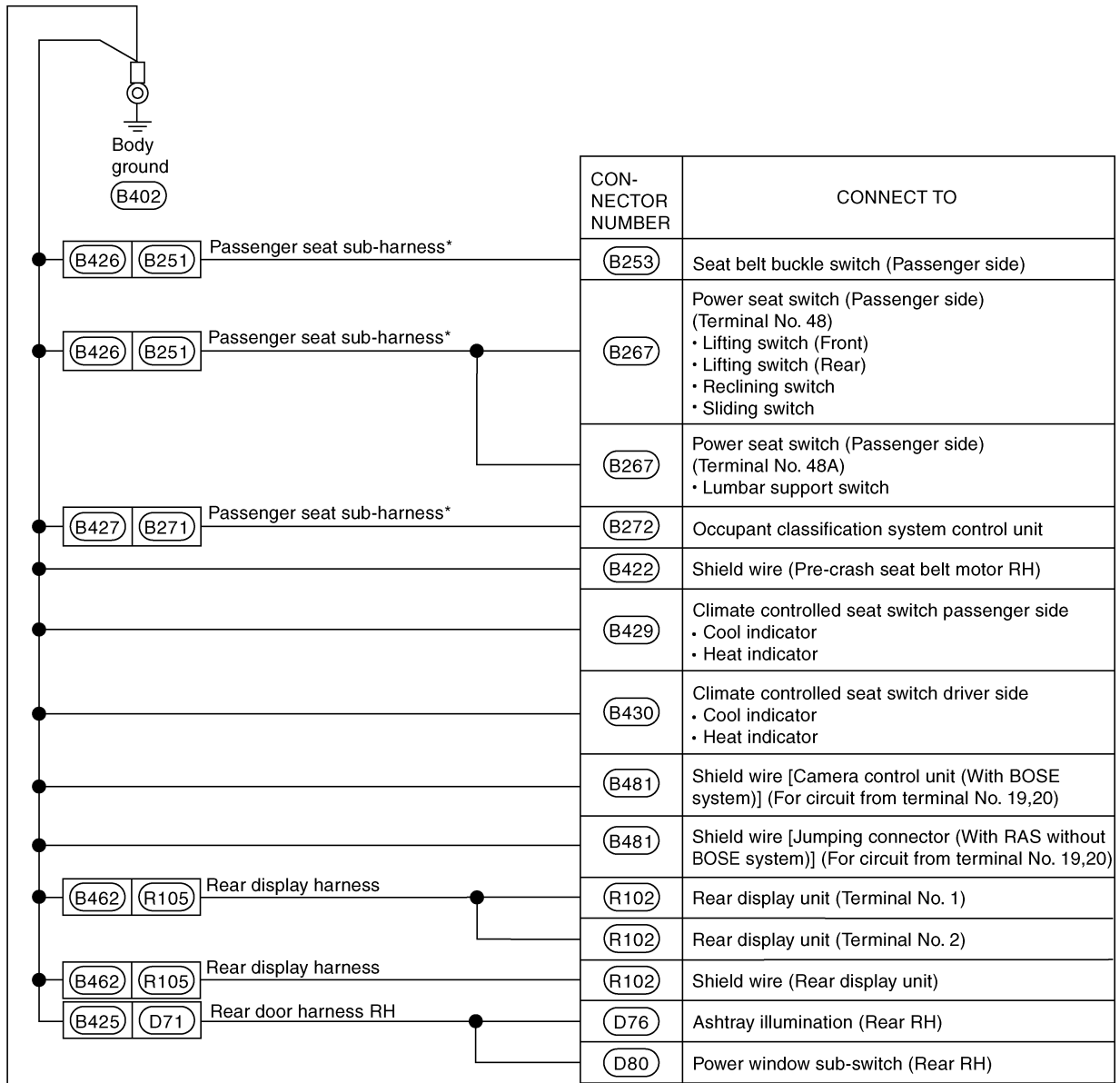

\* : This sub-harness is not shown in "HARNESS LAYOUT".

Next page

CKIT0835E

# GROUND

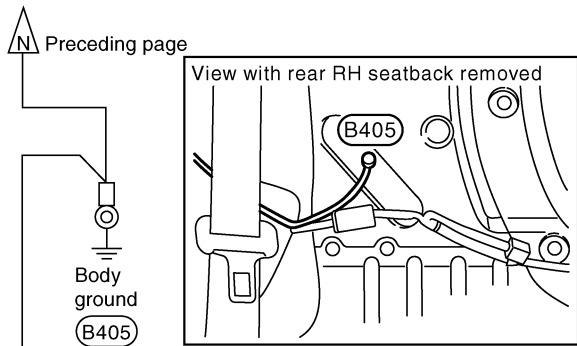

CON-NECTOR NUMBER	CONNECT TO
(B463)	Shield wire (RAS motor)
(B473)	Shield wire [Inside key antenna (Trunk room)]
(B474)	Rear sunshade unit (With built-in motor) (Terminal No. 2)
(B474)	Rear sunshade unit (With built-in motor) (Terminal No. 6)
(B476)	RAS control unit
(B478)	Noise Suppressor (With RAS)
(B480)	RAS motor relay
(B481)	Camera control unit
(B481)	Shield wire [Jumping connector (With RAS without BOSE system)] (For circuit from terminal No. 17,18)
(T102)	Back-up lamp RH
(T104)	Trunk lid key cylinder switch
(T105)	License plate lamp RH
(T106)	Trunk lid lock assembly • Trunk room lamp switch • Trunk lid opener actuator
(T107)	Trunk opener request switch
(T108)	License plate lamp LH
(T110)	Back-up lamp LH

A  
B  
C  
D  
E  
F  
G  
H  
I  
J  
PG  
L  
M

CKIT0836E

# HARNESS

## HARNESS

PFP:00011

### Harness Layout

NKS004ES

#### HOW TO READ HARNESS LAYOUT

The following Harness Layouts use a map style grid to help locate connectors on the figures:

- Main Harness (Instrument Panel)
- Engine Room Harness (Engine Compartment)
- Engine Control Harness (Engine Compartment)
- Body Harness
- Body No. 2 Harness

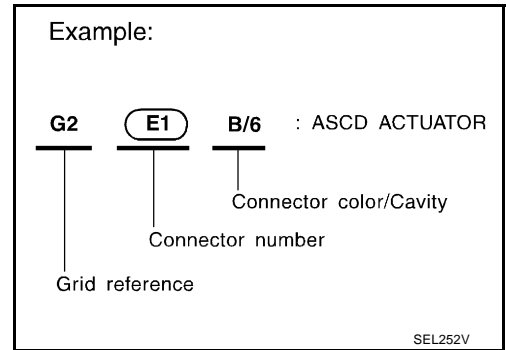

#### To Use the Grid Reference

1. Find the desired connector number on the connector list.
2. Find the grid reference.
3. On the figure, find the crossing of the grid reference letter column and number row.
4. Find the connector number in the crossing zone.
5. Follow the line (if used) to the connector.

#### CONNECTOR SYMBOL

Main symbols of connector (in Harness Layout) are indicated in the below.

Connector type	Water proof type		Standard type	
	Male	Female	Male	Female
<ul style="list-style-type: none"> <li>• Cavity: Less than 4</li> <li>• Relay connector</li> </ul>				
<ul style="list-style-type: none"> <li>• Cavity: From 5 to 8</li> </ul>				
<ul style="list-style-type: none"> <li>• Cavity: More than 9</li> </ul>				
<ul style="list-style-type: none"> <li>• Ground terminal etc.</li> </ul>	—			

CKIT0108E

# HARNESS

## OUTLINE

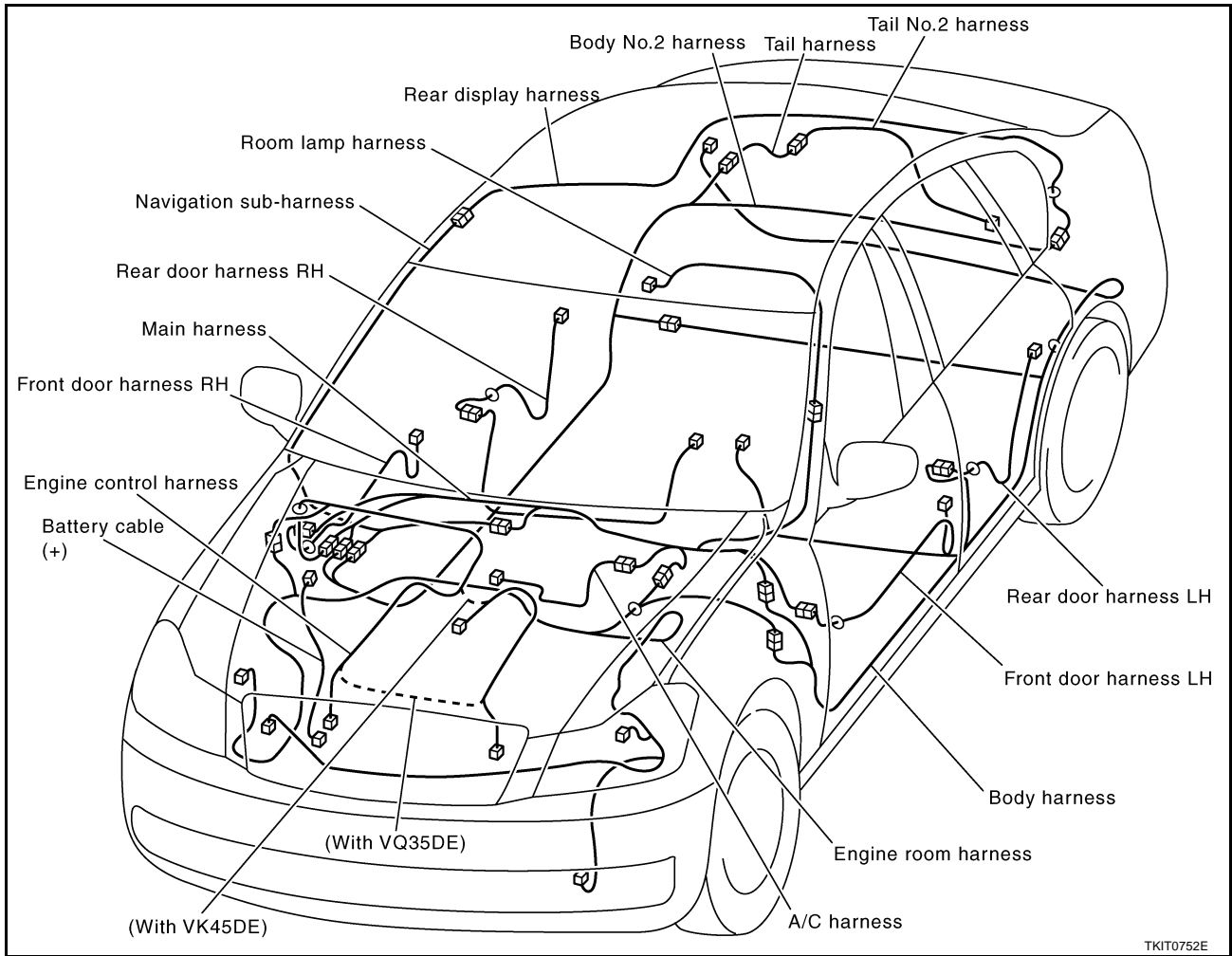

A  
B  
C  
D  
E  
F  
G  
H  
I  
J

PG

L  
M

# HARNESS

## MAIN HARNESS Instrument Panel

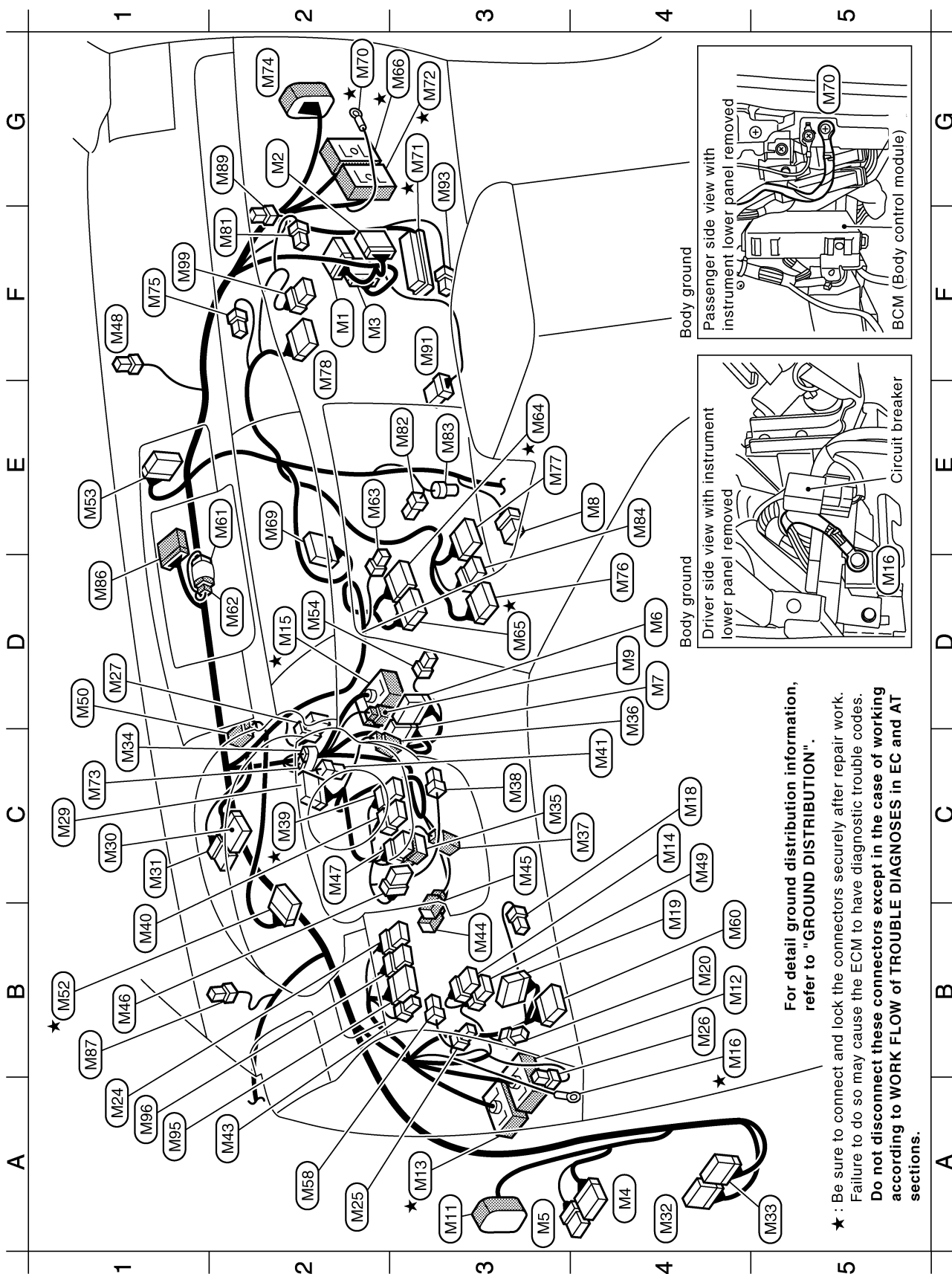

For detail ground distribution information, refer to "GROUND DISTRIBUTION".

★ : Be sure to connect and lock the connectors securely after repair work. Failure to do so may cause the ECM to have diagnostic trouble codes. Do not disconnect these connectors except in the case of working according to WORK FLOW of TROUBLE DIAGNOSES in EC and AT sections.

TKIT0753E



# HARNESSES

F2	(M1)	W/40	:	BCM (Body control module)	F1	(M48)	W/3	:	Optical sensor
G2	(M2)	B/16	:	BCM (Body control module)	C4	(M49)	GR/8	:	LDW switch (With lane departure warning)
F2	(M3)	W/16	:	BCM (Body control module)	D1	(M50)	W/3	:	To (M251)
A4	(M4)	W/16	:	Fuse block (J/B)	B1	(M52)	W/24	:	Combination meter
A3	(M5)	W/8	:	Fuse block (J/B)	E1	(M53)	W/24	:	To (M216)
D4	(M6)	W/32	:	Automatic drive positioner control unit	D2	(M54)	W/2	:	In-vehicle sensor
D4	(M7)	W/16	:	Automatic drive positioner control unit	A2	(M58)	BR/4	:	LDW chime (With lane departure warning)
E4	(M8)	W/8	:	Power steering control unit	B4	(M60)	W/16	:	Data link connector
D4	(M9)	Y/4	:	To (E126)	E2	(M61)	W/2	:	To (M62)
A3	(M11)	SMJ	:	To (D1)	D2	(M62)	W/2	:	To (M61)
B4	(M12)	SMJ	:	To (B1)	E2	(M63)	W/4	:	Clock
A3	(M13)	SMJ	:	To (B2)	E3	(M64)	W/40	:	Unified meter and A/C amp.
C4	(M14)	W/8	:	Key slot	D3	(M65)	W/32	:	Unified meter and A/C amp.
D2	(M15)	SMJ	:	To (E108)	G3	(M66)	SMJ	:	To (B418)
B4	(M16)	—	:	Body ground	E2	(M69)	W/16	:	Multifunction switch
C4	(M18)	W/2	:	Foot lamp (Driver side)	G2	(M70)	—	:	Body ground
B4	(M19)	W/32	:	Low tire pressure warning control unit	G3	(M71)	SMJ	:	ECM
B4	(M20)	W/2	:	Tire pressure warning check connector	G3	(M72)	SMJ	:	To (E102)
A1	(M24)	GR/6	:	VDC off switch	C1	(M73)	W/2	:	Diode
A2	(M25)	W/4	:	Trunk lid opener switch	G2	(M74)	SMJ	:	To (D31)
B4	(M26)	W/2	:	Circuit breaker	F1	(M75)	Y/4	:	Front passenger air bag module
D1	(M27)	BR/8	:	Push-button ignition switch	D4	(M76)	W/20	:	Audio unit
C1	(M29)	W/16	:	Combination switch	E3	(M77)	W/12	:	Audio unit
C1	(M30)	W/12	:	PDU (Power distribution unit)	F2	(M78)	W/40	:	AV control unit (Without navigation system)
C1	(M31)	W/6	:	PDU (Power distribution unit)	F2	(M81)	BR/2	:	NAV1 control unit (With navigation system)
A4	(M32)	W/40	:	Intelligent Key unit	F2	(M81)	BR/2	:	Glove box lamp
A5	(M33)	W/32	:	Intelligent Key unit	E3	(M82)	W/4	:	Intake sensor
C1	(M34)	W/2	:	Diode	E3	(M83)	GR/2	:	Inside key antenna (Instrument center)
C3	(M35)	W/8	:	Steering lock unit	E4	(M84)	W/8	:	Audio unit
D4	(M36)	W/2	:	Tilt motor	D1	(M86)	W/16	:	To (M215) (For navigation system or rear view monitor)
C4	(M37)	W/3	:	Tilt sensor	B1	(M87)	B/2	:	Sunload sensor
C3	(M38)	BR/2	:	Microphone (For audio pilot)	G2	(M89)	B/4	:	Remote keyless entry receiver
C2	(M39)	GR/8	:	Combination switch (Spiral cable)	F3	(M91)	W/6	:	Blower motor
B1	(M40)	Y/6	:	Combination switch (Spiral cable)	G3	(M93)	W/2	:	Foot lamp (Passenger side)
C4	(M41)	L/4	:	Resistor	A1	(M95)	BR/16	:	Door mirror remote control switch
A2	(M43)	W/3	:	Illumination control switch	A1	(M96)	W/6	:	AFS switch
B3	(M44)	W/3	:	Telescopic sensor	F1	(M99)	W/6	:	Trunk lid opener cancel switch
C3	(M45)	W/2	:	Telescopic motor	★ : Be sure to connect and lock the connectors securely after repair work. Failure to do so may cause the ECM to have diagnostic trouble codes. <b>Do not disconnect these connectors except in the case of working according to WORK FLOW of TROUBLE DIAGNOSES in EC and AT sections.</b>				
B1	(M46)	GR/6	:	ADP steering switch					
C2	(M47)	W/8	:	Steering angle sensor					

TKIT0754E

# HARNESS

Diode (M34)

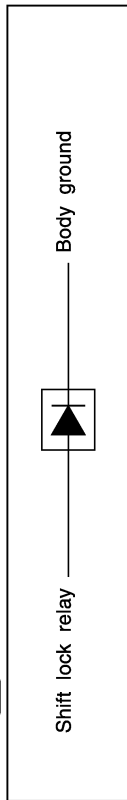

Diode (M73)

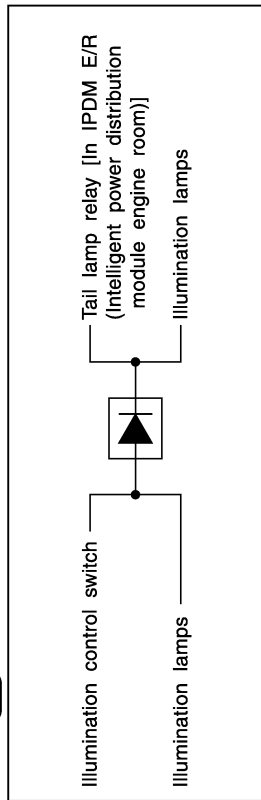

TKIT0444E

## Floor Console

### Console sub-harness-1 (With DVD player)

(M271) W/32 : To (M143)  
 (M272) W/32 : DVD player

### Console sub-harness-2 (With DVD player)

(M281) W/16 : To (M144)  
 (M282) W/16 : DVD player

### Console sub-harness-3 (With DVD player)

(M291) W/2 : To (M148)  
 (M292) - : DVD player

- (M132) W/3 : Cigarette lighter socket
- (M133) W/10 : A/T device
- (M134) BR/2 : A/T illumination
- (M135) W/8 : Snow mode switch
- (M137) W/6 : Rear sunshade front switch
- (M139) - : Body ground (With DVD player)
- (M140) B/2 : Power socket (Floor console inside)
- (M142) GR/2 : Inside key antenna (Console)
- (M143) W/32 : To (M271) (With DVD player)
- (M144) W/16 : To (M281) (With DVD player)
- (M145) B/6 : Yaw rate / side G sensor
- (M147) Y/28 : Air bag diagnosis sensor unit
- (M148) W/2 : To (M291) (With DVD player)
- (M149) W/8 : Auxiliary input jacks and power socket (Via sub-harness)

- (M151) W/8 : Floor console rear
- (M153) W/4 : Rear control cancel switch
- (M153) W/4 : To (B431) (For rear view monitor)

Body ground

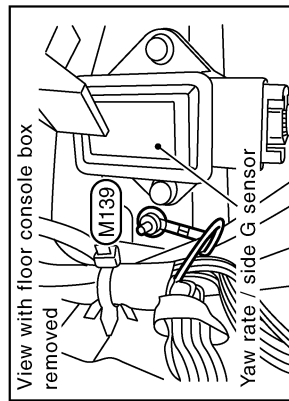

For detail ground distribution information, refer to "GROUND DISTRIBUTION".

★ : Be sure to connect and lock the connectors securely after repair work. Failure to do so may cause the ECM to have diagnostic trouble codes. **Do not disconnect these connectors except in the case of working according to WORK FLOW of TROUBLE DIAGNOSES in EC and AT sections.**

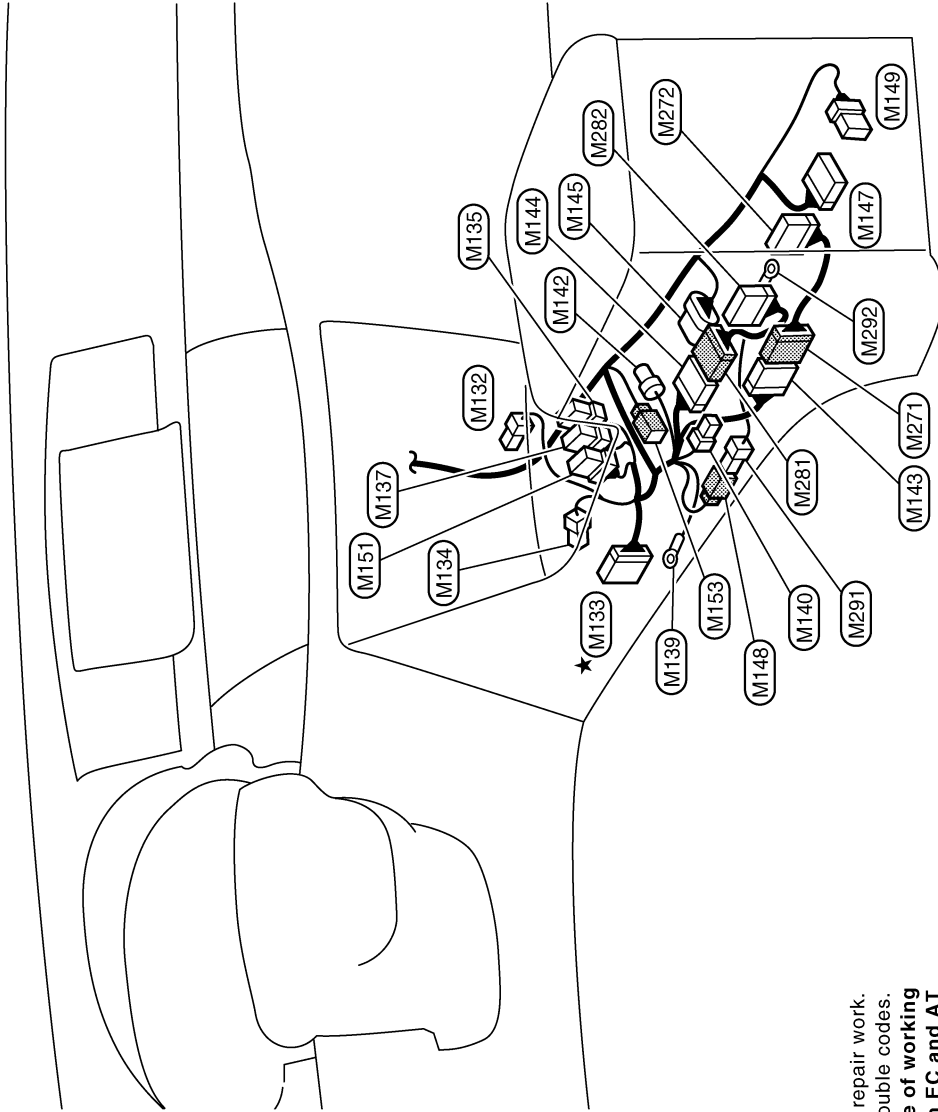

A  
B  
C  
D  
E  
F  
G  
H  
I  
J  
L  
M  
PG

# HARNESS

Roof

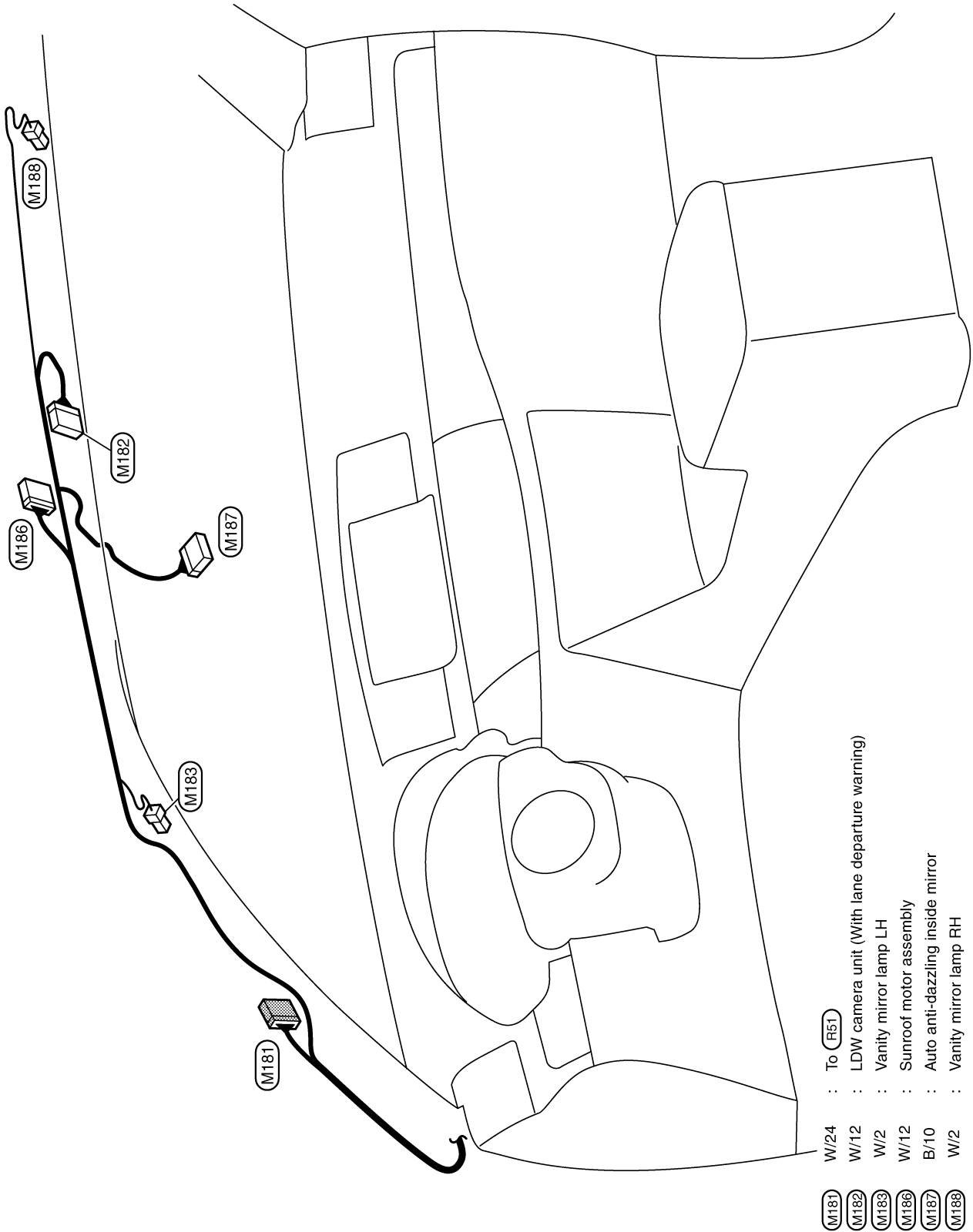

- M181
  - M182
  - M183
  - M186
  - M187
  - M188
- W/24 : To (R51)
  - W/12 : LDW camera unit (With lane departure warning)
  - W/2 : Vanity mirror lamp LH
  - W/12 : Sunroof motor assembly
  - B/10 : Auto anti-dazzling inside mirror
  - W/2 : Vanity mirror lamp RH

TKIT0756E

# HARNESS

## NAVIGATION SUB-HARNESS & A/C HARNESS

### A/C harness

- (M251) W/3 : To (M50)
- (M252) W/3 : Mode door motor (Driver side)
- (M253) W/3 : Air mix door motor (Driver side)
- (M254) W/3 : Upper ventilator door motor
- (M255) W/3 : Mode door motor (Passenger side)
- (M256) W/3 : Air mix door motor (Passenger side)
- (M257) W/3 : Intake door motor

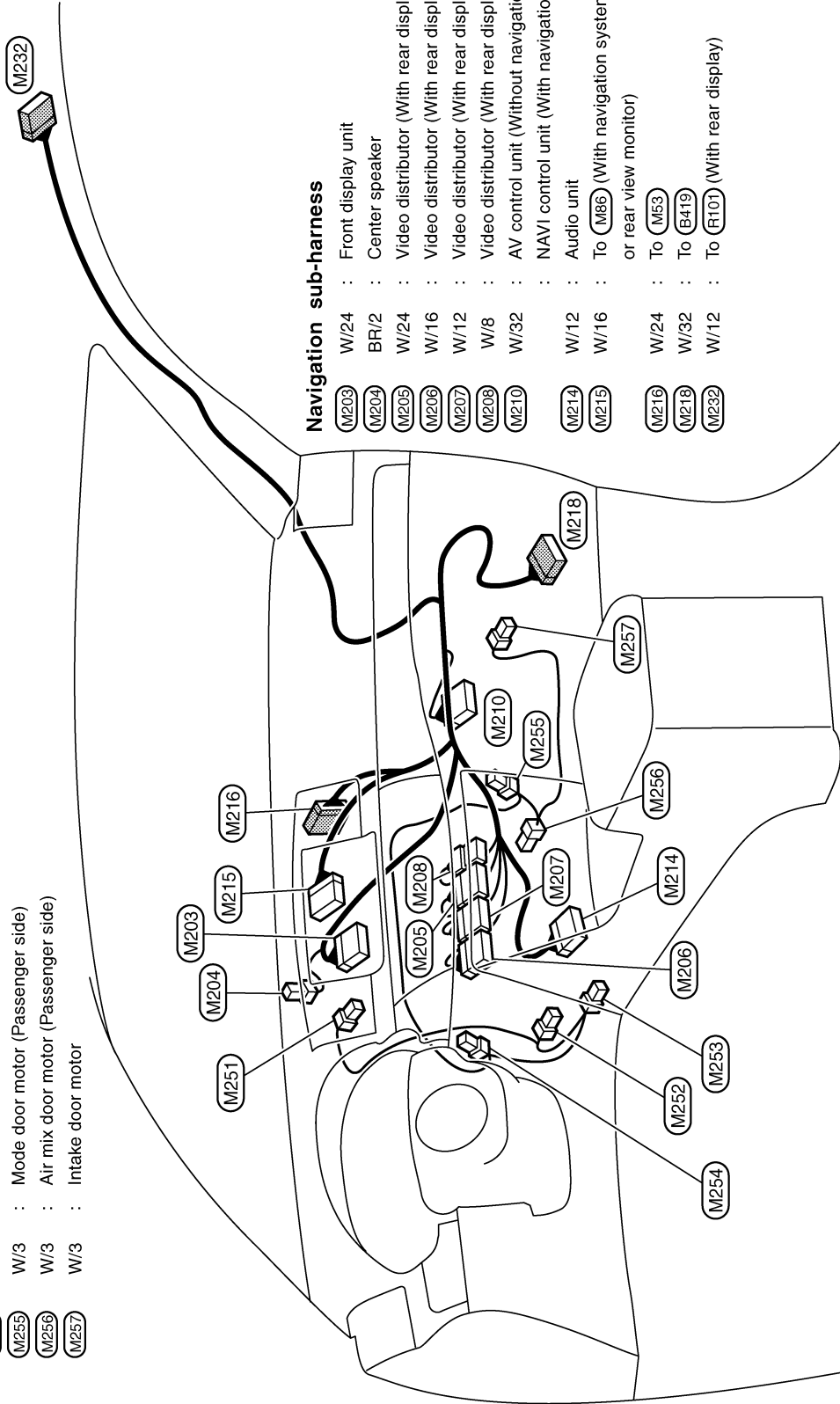

### Navigation sub-harness

- (M203) W/24 : Front display unit
- (M204) BR/2 : Center speaker
- (M205) W/24 : Video distributor (With rear display)
- (M206) W/16 : Video distributor (With rear display)
- (M207) W/12 : Video distributor (With rear display)
- (M208) W/8 : Video distributor (With rear display)
- (M210) W/32 : AV control unit (Without navigation system)
- (M214) W/12 : Audio unit
- (M215) W/16 : To (M86) (With navigation system or rear view monitor)
- (M216) W/24 : To (M53)
- (M218) W/32 : To (E419)
- (M232) W/12 : To (F101) (With rear display)

A  
B  
C  
D  
E  
F  
G  
H  
I  
J  
PG  
L  
M

TKIT0757E

# HARNESS

## ENGINE ROOM HARNESS Engine Compartment

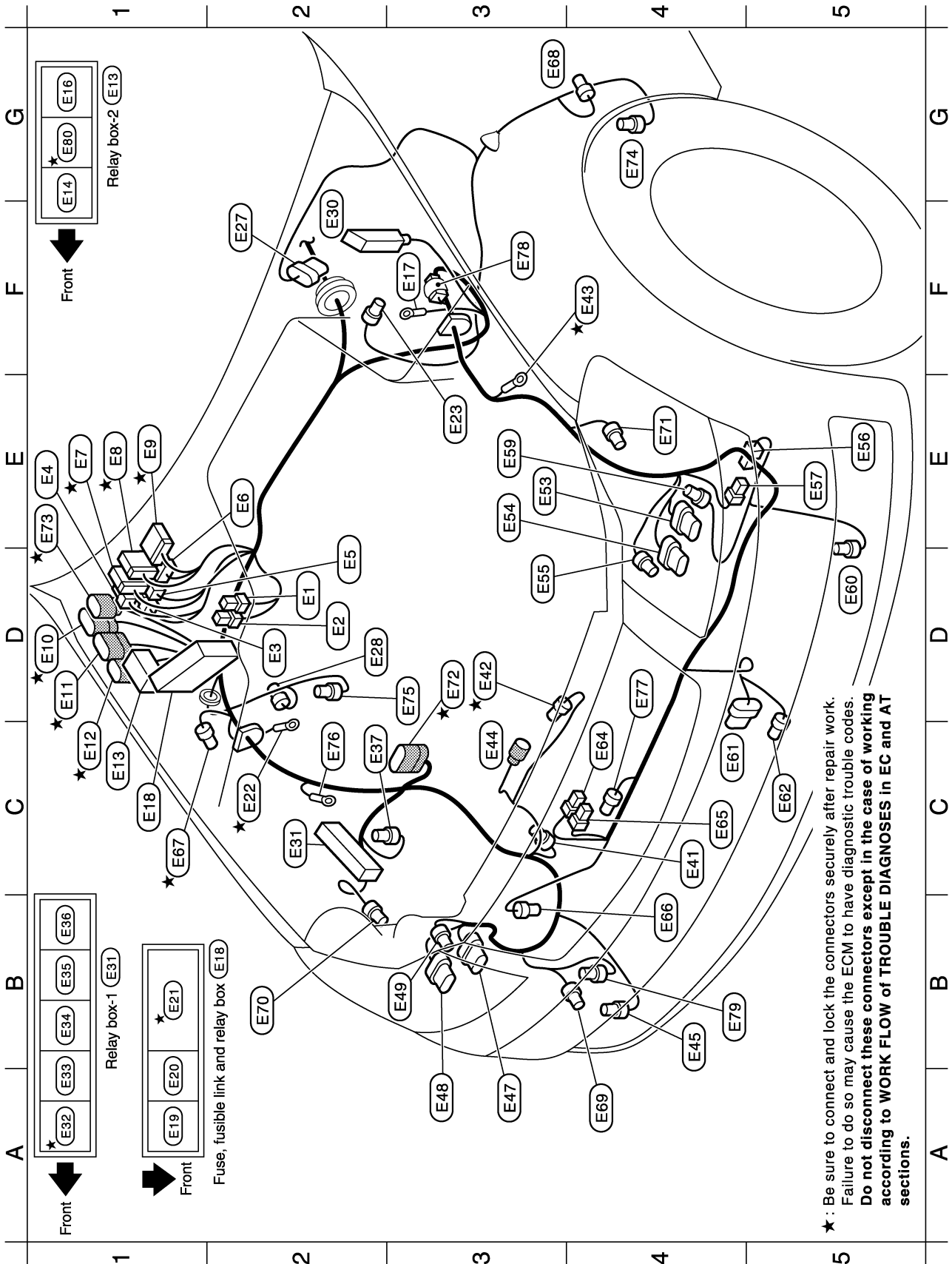

★ : Be sure to connect and lock the connectors securely after repair work.  
Failure to do so may cause the ECM to have diagnostic trouble codes.  
Do not disconnect these connectors except in the case of working according to WORK FLOW of TROUBLE DIAGNOSES in EC and AT sections.

TKIT0448E

# HARNESSES

A  
B  
C  
D  
E  
F  
G  
H  
I  
J  
PG  
L  
M

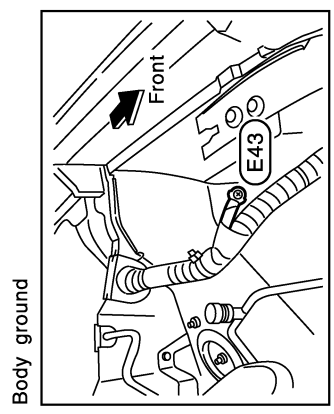
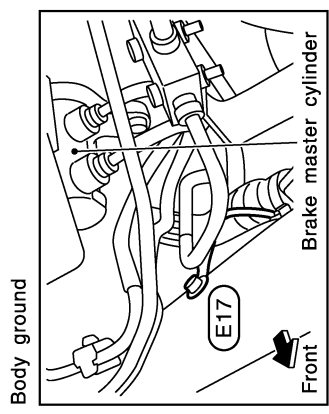
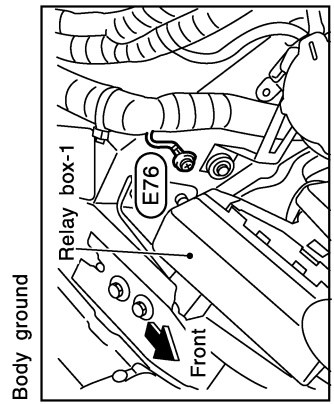
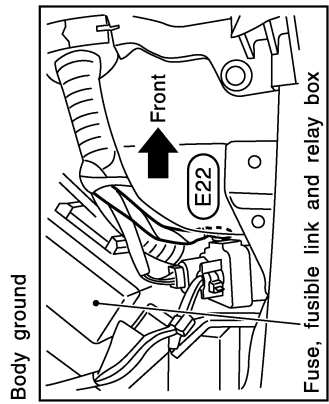

For detail ground distribution information, refer to "GROUND DISTRIBUTION".

# HARNESSES

D2	(E1)	BR/2	: Fusible link holder	E3	(E53)	GR/8	: Front combination lamp LH (With xenon headlamp)
D2	(E2)	GR/2	: Fusible link holder	E3	(E54)	B/8	: Front combination lamp LH
D2	(E3)	B/2	: IPDM E/R (Intelligent power distribution module engine room)	D3	(E55)	GR/2	: Front combination lamp LH
E1	(E4)	W/4	: IPDM E/R (Intelligent power distribution module engine room)	E5	(E56)	B/1	: Horn (Low)
D2	(E5)	B/4	: IPDM E/R (Intelligent power distribution module engine room)	E5	(E57)	B/1	: Horn (Low)
E2	(E6)	W/6	: IPDM E/R (Intelligent power distribution module engine room)	E3	(E59)	B/2	: Front wheel sensor LH
E1	(E7)	GR/16	: IPDM E/R (Intelligent power distribution module engine room)	D5	(E60)	-/2	: Front fog lamp LH
E1	(E8)	W/12	: IPDM E/R (Intelligent power distribution module engine room)	C4	(E61)	B/6	: ICC sensor integrated unit (With ICC)
E1	(E9)	W/16	: IPDM E/R (Intelligent power distribution module engine room)	C5	(E62)	B/2	: Ambient sensor
D1	(E10)	GR/9	: To (F1) (With VQ35DE)	C4	(E64)	B/1	: Horn (High)
D1	(E11)	B/10	: To (F2)	C4	(E65)	B/1	: Horn (High)
C1	(E12)	B/8	: To (F3)	B4	(E66)	B/3	: Refrigerant pressure sensor
C1	(E13)	—	: Relay box-2	C1	(E67)	B/3	: Battery current sensor
G1	(E14)	—	: Fuse block-2	G3	(E68)	G/2	: Side turn signal lamp LH
G1	(E16)	BR/6	: Climate controlled seat relay	A4	(E69)	GR/2	: Front washer motor
F3	(E17)	—	: Body ground	B2	(E70)	GR/3	: Front combination lamp RH (Aiming motor)
C1	(E18)	—	: Fuse, fusible link and relay box				(With xenon headlamp)
A1	(E19)	L/4	: Back-up lamp relay	E4	(E71)	GR/3	: Front combination lamp LH (Aiming motor)
A1	(E20)	—	: Fuse and fusible link block (Horn relay)				(With xenon headlamp)
B1	(E21)	—	: Fuse and fusible link block	D3	(E72)	GR/9	: To (E206) (With VK45DE)
C2	(E22)	—	: Body ground	E1	(E73)	B/8	: To (F68) (With VK45DE)
E3	(E23)	GR/2	: Brake fluid level switch	G4	(E74)	B/4	: Tire pressure receiver front LH
F2	(E27)	GR/6	: Front wiper motor	D3	(E75)	B/4	: Tire pressure receiver front RH
D2	(E28)	G/2	: Side turn signal lamp RH	C2	(E76)	—	: Body ground
F2	(E30)	SMJ	: ABS actuator and electric unit (Control unit)	D4	(E77)	Y/2	: Crash zone sensor
C2	(E31)	—	: Relay box-1	F3	(E78)	BR/2	: Resistor
A1	(E32)	-/4	: Cooling fan relay	B4	(E79)	BR/2	: Washer level sensor
A1	(E33)	B/5	: Front wiper reverse relay	G1	(E80)	L/4	: ICC brake hold relay (With ICC)
B1	(E34)	B/5	: Daytime light relay (For Canada)				
B1	(E35)	L/4	: Shift lock relay				
B1	(E36)	BR/6	: Rear window defogger relay				
C2	(E37)	BR/3	: Intelligent Key warning buzzer				
C4	(E41)	B/2	: Front wheel sensor RH				
D3	(E42)	GR/3	: Cooling fan control module				
F4	(E43)	—	: Body ground				
C3	(E44)	GR/2	: Hood switch				
B4	(E45)	-/2	: Front fog lamp RH				
A3	(E47)	B/8	: Front combination lamp RH				
A3	(E48)	GR/8	: Front combination lamp RH (With xenon headlamp)				
B3	(E49)	GR/2	: Front combination lamp RH				

★ : Be sure to connect and lock the connectors securely after repair work.  
 Failure to do so may cause the ECM to have diagnostic trouble codes.  
**Do not disconnect these connectors except in the case of working according to WORK FLOW of TROUBLE DIAGNOSES in EC and AT sections.**

TKIT0450E



# HARNESS

## Passenger Compartment

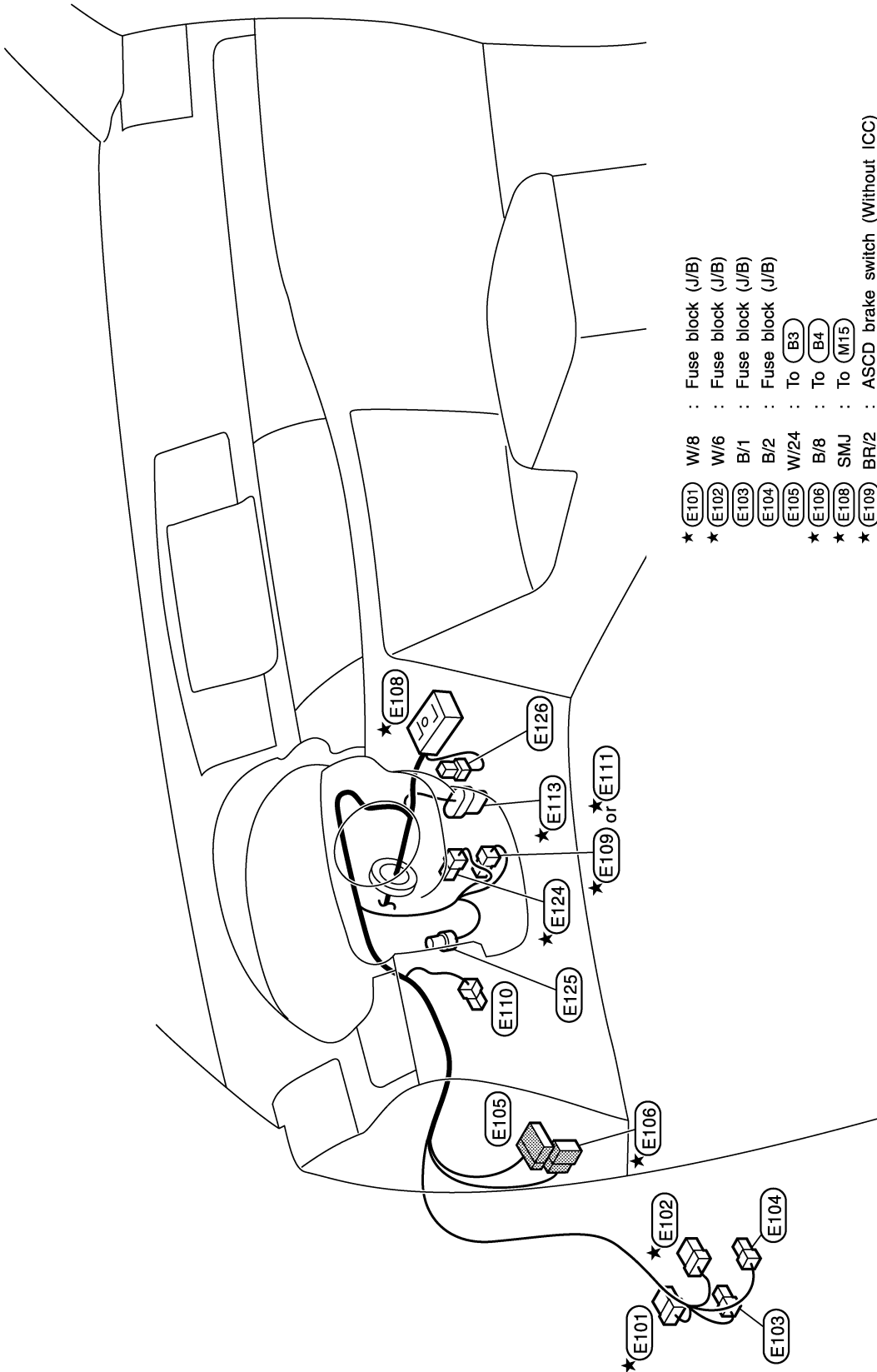

- ★ E101 W/8 : Fuse block (J/B)
- ★ E102 W/6 : Fuse block (J/B)
- E103 B/1 : Fuse block (J/B)
- E104 B/2 : Fuse block (J/B)
- E105 W/24 : To B3
- E106 B/8 : To B4
- ★ E108 SMJ : To M15
- ★ E109 BR/2 : ASCD brake switch (Without ICC)
- E110 W/1 : Parking brake switch
- E111 BR/2 : ICC brake switch (With ICC)
- ★ E113 B/6 : Accelerator pedal position sensor
- ★ E124 W/4 : Stop lamp switch
- E125 B/4 : Brake pedal stroke sensor (With pre-crash seat belt)
- E126 Y/4 : To M9

★ : Be sure to connect and lock the connectors securely after repair work.  
 Failure to do so may cause the ECM to have diagnostic trouble codes.  
 Do not disconnect these connectors except in the case of working  
 according to WORK FLOW of TROUBLE DIAGNOSES in EC and AT  
 sections.

TKIT0451E

A  
B  
C  
D  
E  
F  
G  
H  
I  
J  
L  
M

# HARNESS

## Battery Cable (2WD Models with VQ Engine)

- (E201) : Fusible link holder
- (E203) : Starter motor
- (E205) : Alternator (B)
- (E221) : Alternator (E)
- (E222) : Body ground
- (E223) : Engine ground
- (E224) : Body ground

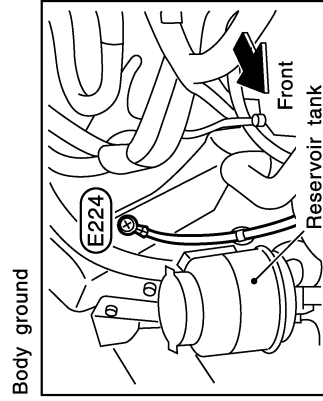
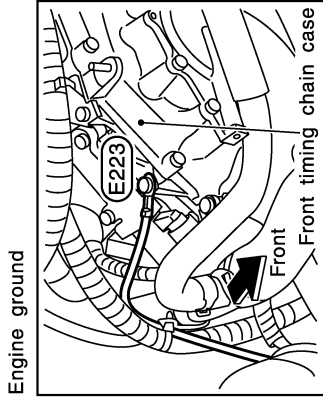
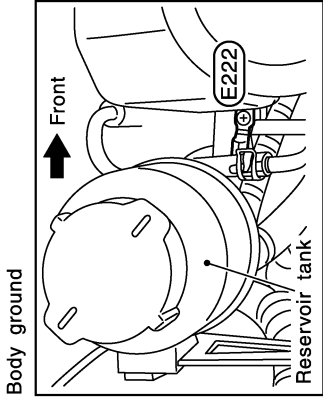
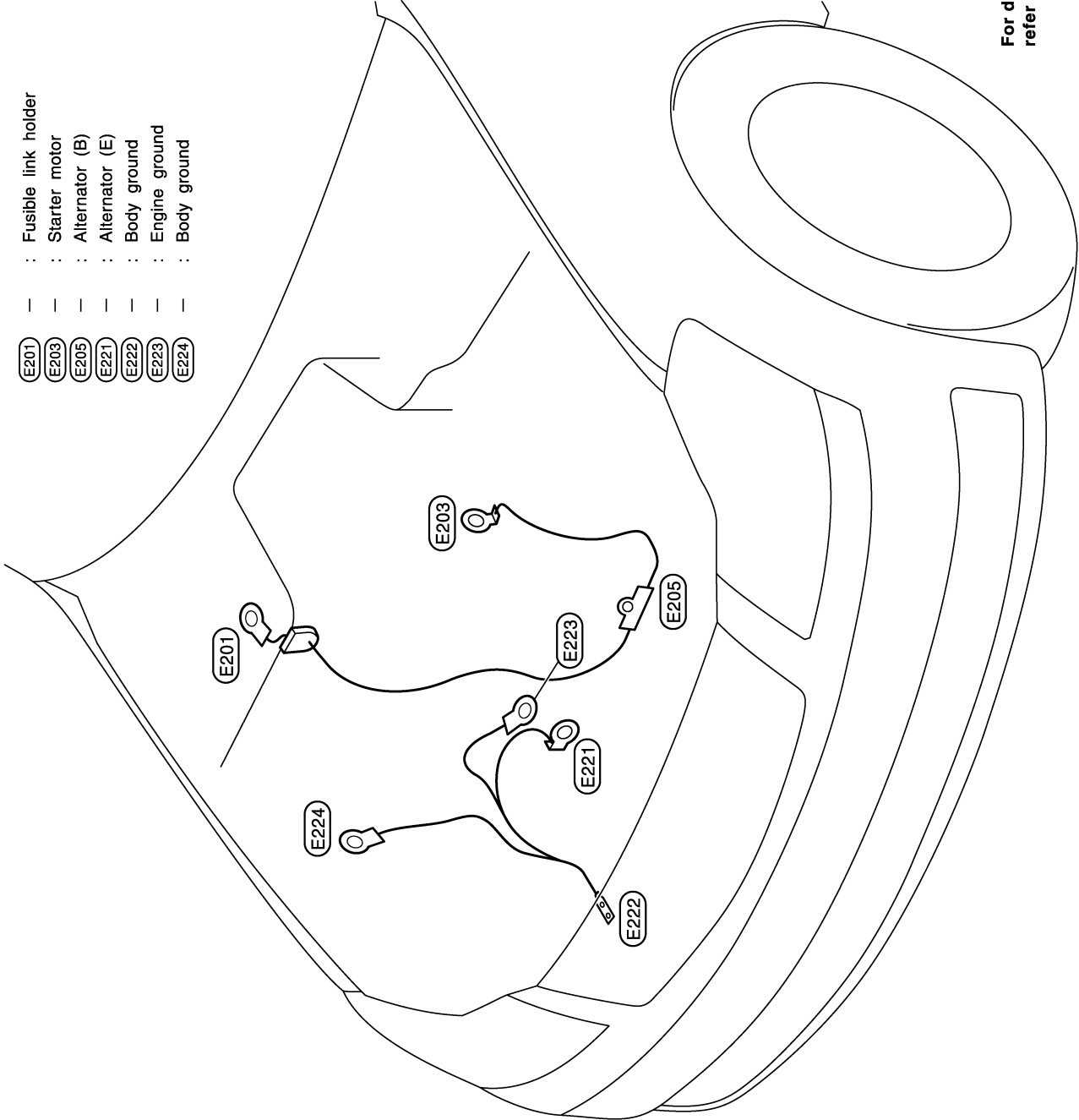

For detail ground distribution information, refer to "GROUND DISTRIBUTION".

TKIT0452E

# HARNESS

## Battery Cable (AWD Models with VQ Engine)

- (E201) : Fusible link holder
- (E202) : Alternator (B)
- (E203) : Starter motor
- (E204) : Fusible link holder
- (E221) : Alternator (E)
- (E222) : Body ground
- (E223) : Engine ground
- (E224) : Body ground

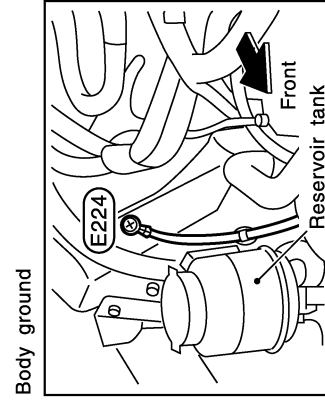
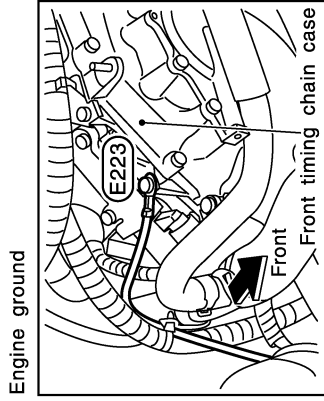
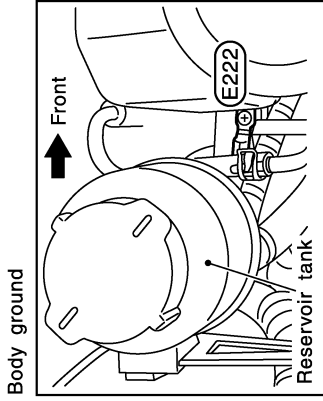
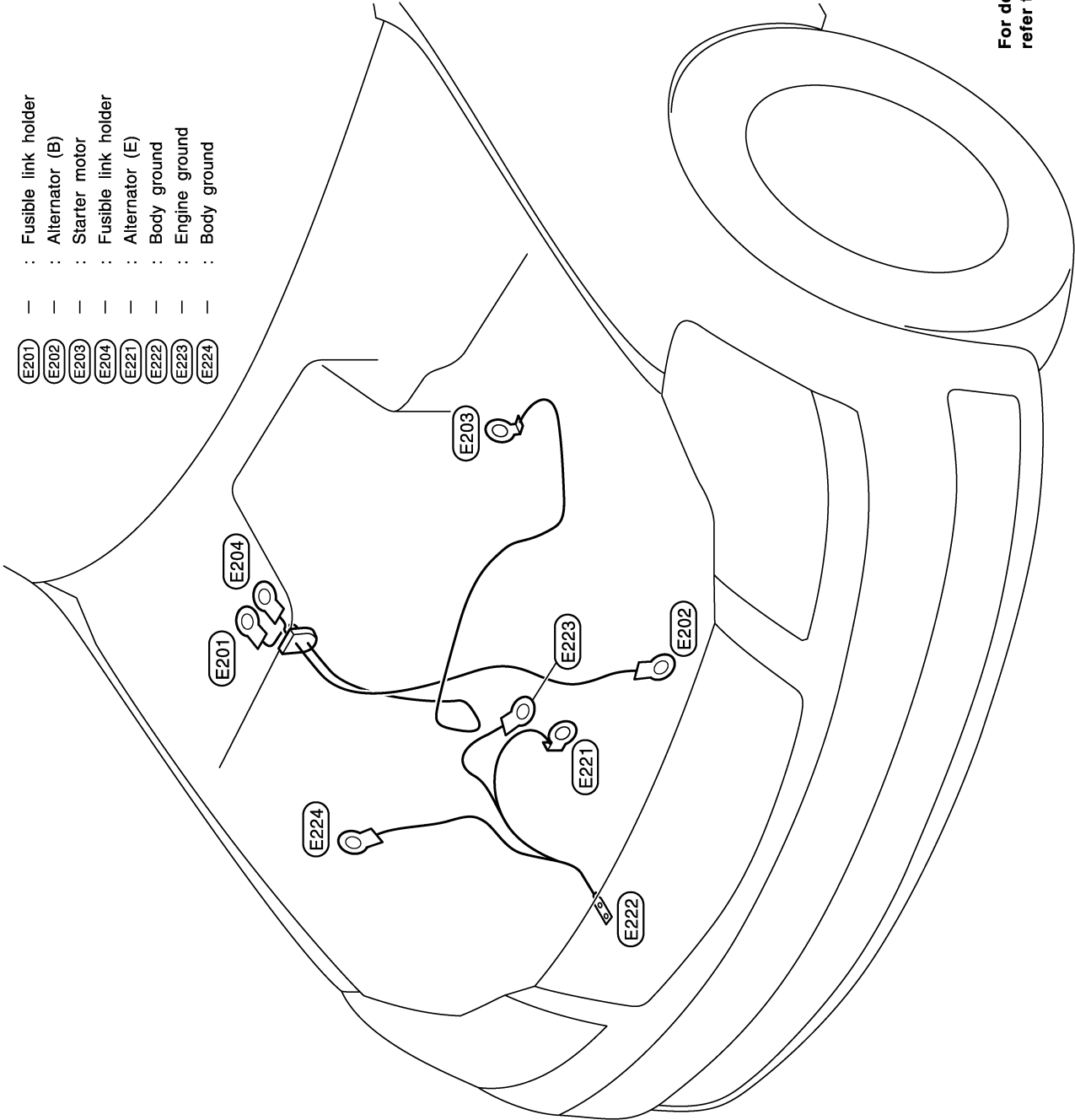

For detail ground distribution information, refer to "GROUND DISTRIBUTION".

A  
B  
C  
D  
E  
F  
G  
H  
I  
J  
PG  
L  
M

# HARNESS

## Battery Cable (VK Engine)

- (E201) : Fusible link holder
- (E202) : Alternator (B)
- (E203) : Starter motor
- (E204) : Fusible link holder
- ★ (E206) GR/9 : To (E72)

- (E207) : Alternator (E)
- ★ (E208) B/3 : Power steering pressure sensor
- (E209) B/3 : Alternator (S<sub>1</sub>,L,C)
- (E210) GR/1 : Starter motor
- (E211) BR/2 : Power steering solenoid valve
- (E212) : Body ground
- (E222) : Body ground
- (E223) : Engine ground

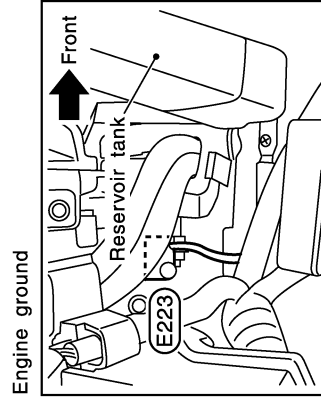
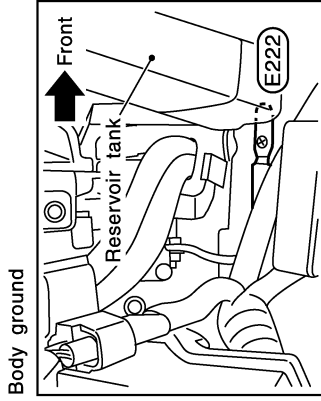
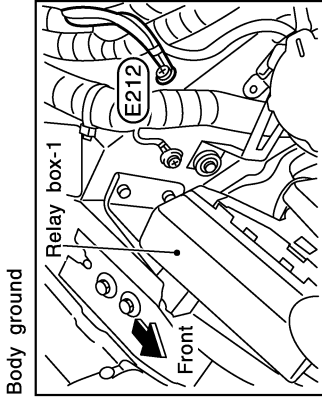
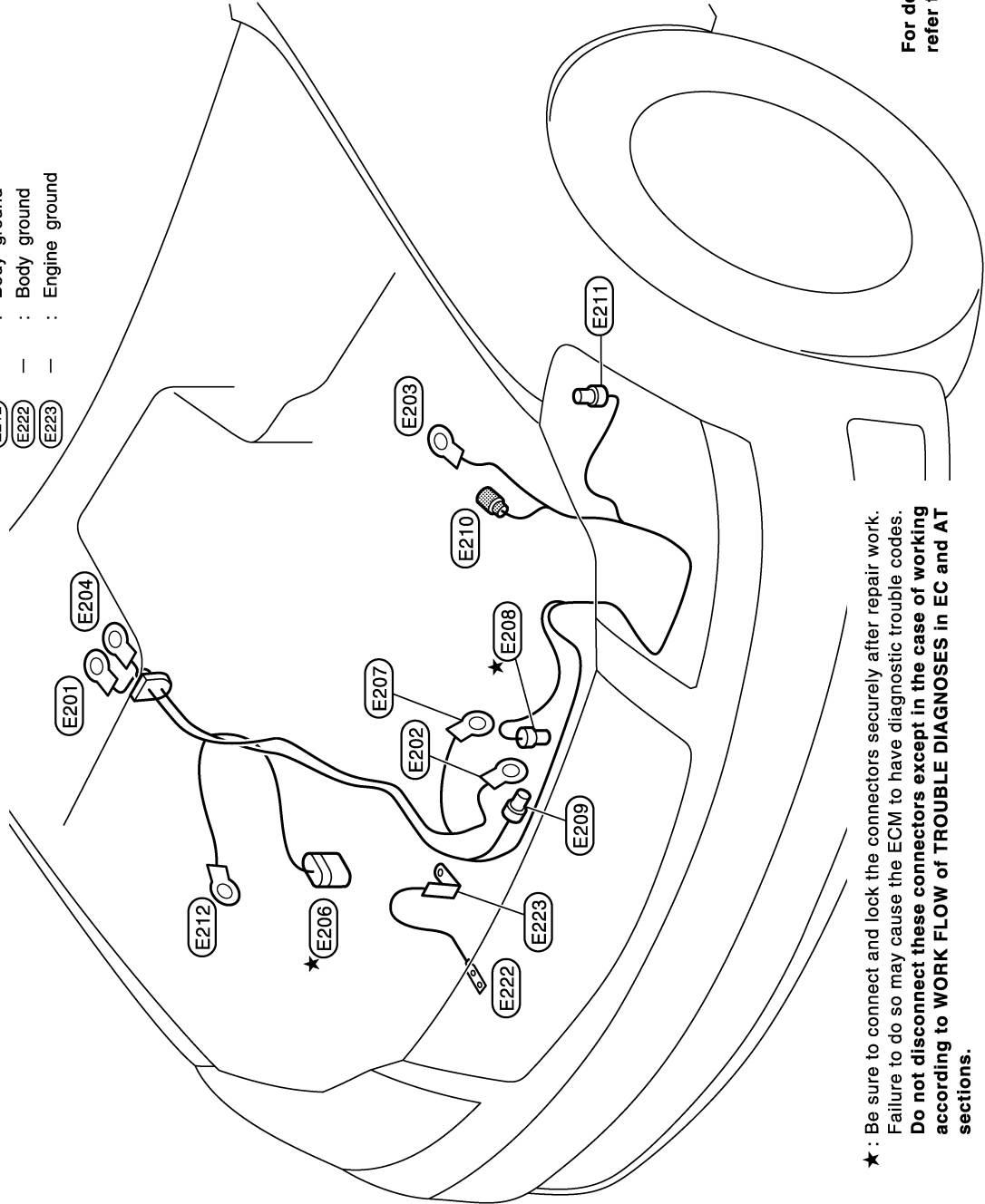

★ : Be sure to connect and lock the connectors securely after repair work. Failure to do so may cause the ECM to have diagnostic trouble codes. Do not disconnect these connectors except in the case of working according to WORK FLOW of TROUBLE DIAGNOSES in EC and AT sections.

For detail ground distribution information, refer to "GROUND DISTRIBUTION".

TKIT0454E



## Engine control sub-harness-1

C2	★	(F201)	L/6	:	To	(F18)
B3		(F202)	GR/3	:	Ignition coil No.3 (With power transistor)	
B3		(F203)	GR/3	:	Ignition coil No.1 (With power transistor)	
B3	★	(F204)	G/2	:	Intake valve timing control solenoid valve (Bank 1)	

## Engine control sub-harness-1

E4	★	(F221)	G/8	:	To	(F33)
C4	★	(F222)	GR/2	:	Fuel injector No.1	
C3	★	(F223)	GR/2	:	Fuel injector No.3	
C3	★	(F224)	GR/2	:	Fuel injector No.5	
C4	★	(F225)	GR/2	:	Fuel injector No.2	
D4	★	(F226)	GR/2	:	Fuel injector No.4	
D4	★	(F227)	GR/2	:	Fuel injector No.6	
C4	★	(F228)	L/2	:	Knock sensor	
D2	★	(F229)	SB/2	:	To	(F37)

C1	★	(F1)	GR/9	:	To	(E10)
C1	★	(F2)	B/10	:	To	(E11)
C1	★	(F3)	B/8	:	To	(E12)
D2	★	(F4)	G/3	:	Camshaft position sensor (PHASE) (Bank 1)	
D2	★	(F5)	GR/2	:	EVAP canister purge volume control solenoid valve	
E5		(F9)	GR/1	:	Starter motor	
D5	★	(F10)	B/3	:	Crankshaft position sensor (POS)	
D2	★	(F13)	GR/2	:	Engine coolant temperature sensor	
C2		(F15)	GR/3	:	Ignition coil No.5 (With power transistor)	
B2	★	(F18)	L/6	:	To	(F20)
B4	★	(F19)	B/3	:	Power steering pressure sensor	
C4		(F20)	B/3	:	Alternator (S,L,C)	
C4		(F21)	GR/1	:	Oil pressure switch	
C3		(F22)	—	:	Engine ground	
D5		(F24)	B/1	:	Compressor	
D5		(F25)	BR/2	:	Power steering solenoid valve	
D4	★	(F26)	G/2	:	Intake valve timing control solenoid valve (Bank 2)	
F4		(F27)	GR/3	:	Ignition coil No.2 (With power transistor)	
E4		(F28)	GR/3	:	Ignition coil No.4 (With power transistor)	
E3		(F29)	GR/3	:	Ignition coil No.6 (With power transistor)	
E2	★	(F31)	G/6	:	Electric throttle control actuator	
E3	★	(F32)	B/3	:	Camshaft position sensor (PHASE) (Bank 2)	
E2	★	(F33)	G/8	:	To	(F22)
D5		(F34)	GR/2	:	Compressor	
D2	★	(F37)	SB/2	:	To	(F29)
C2		(F38)	W/2	:	Condenser	
E5	★	(F39)	B/6	:	Mass air flow sensor	
C2	★	(F40)	B/6	:	Air fuel ratio (A/F) sensor 1 (Bank 1)	
F4	★	(F41)	B/6	:	Air fuel ratio (A/F) sensor 1 (Bank 2)	
E3	★	(F42)	G/10	:	A/T assembly	
F2		(F43)	B/8	:	Transfer assembly (AWD models)	
C3		(F44)	—	:	Engine ground	
D4	★	(F69)	B/4	:	Heated oxygen sensor 2 (Bank 1)	
E4	★	(F70)	B/4	:	Heated oxygen sensor 2 (Bank 2)	

★ : Be sure to connect and lock the connectors securely after repair work.  
 Failure to do so may cause the ECM to have diagnostic trouble codes.  
**Do not disconnect these connectors except in the case of working according to WORK FLOW of TROUBLE DIAGNOSES in EC and AT sections.**

# HARNESS

## Passenger Compartment

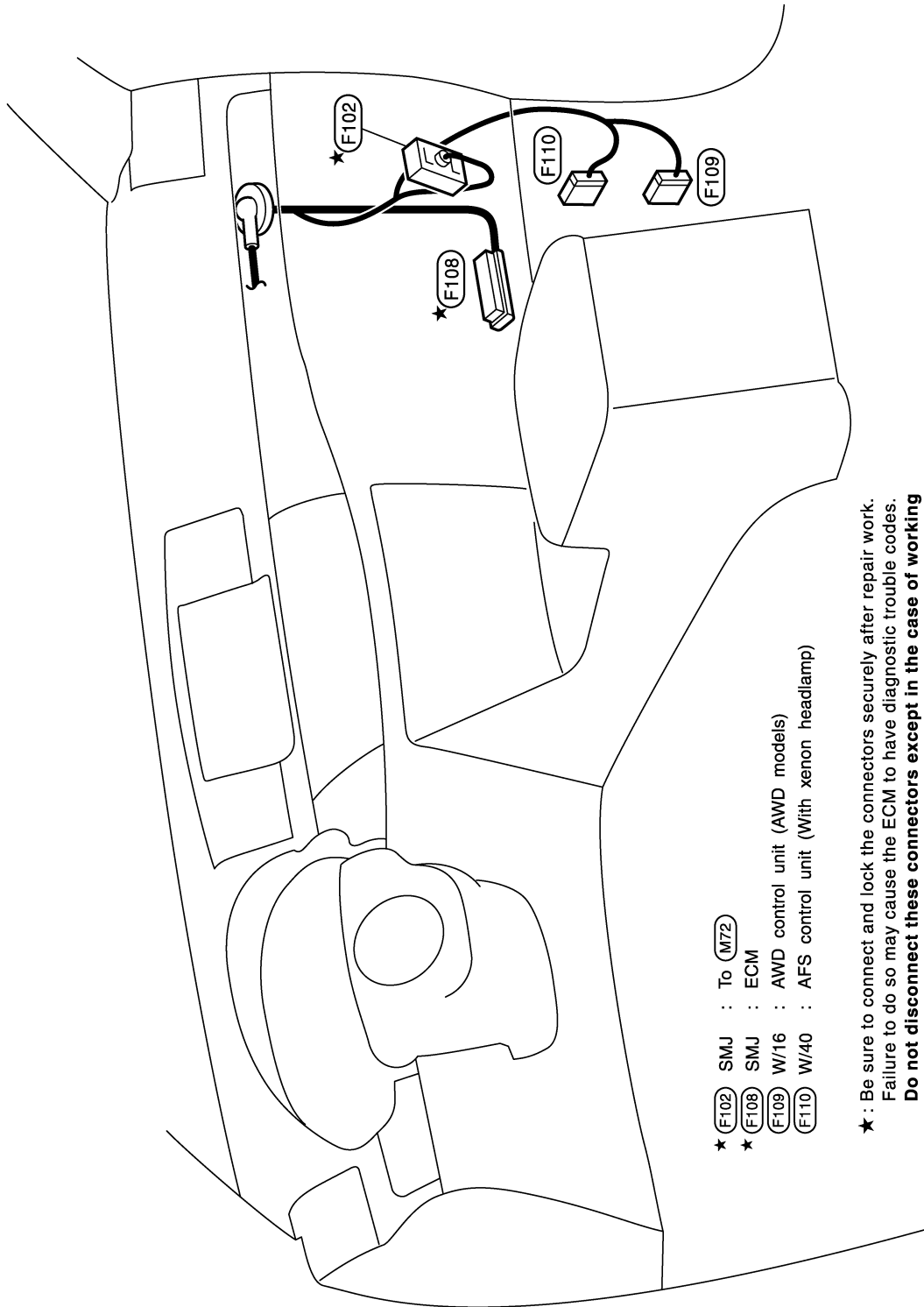

A  
B  
C  
D  
E  
F  
G  
H  
I  
J  
PG  
L  
M

TKIT0457E

# HARNESS

## ENGINE CONTROL HARNESS (VK ENGINE)

### Engine Compartment

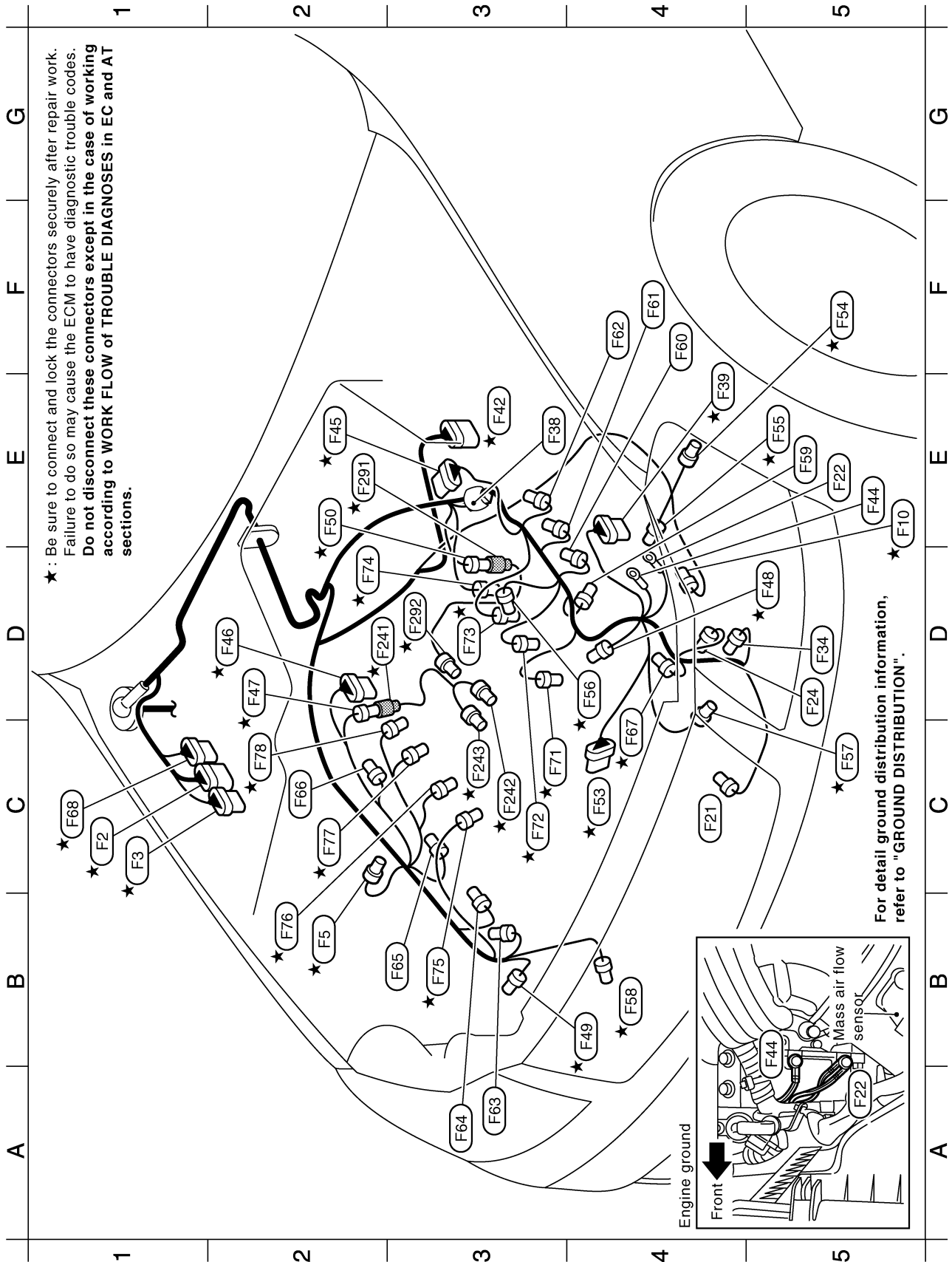

★ : Be sure to connect and lock the connectors securely after repair work. Failure to do so may cause the ECM to have diagnostic trouble codes. Do not disconnect these connectors except in the case of working according to WORK FLOW of TROUBLE DIAGNOSES in EC and AT sections.

For detail ground distribution information, refer to "GROUND DISTRIBUTION".



★ C1	(F2)	B/10	:	To (E11)	GR/2	:	Fuel injector No.1
★ C1	(F3)	B/8	:	To (E12)	GR/2	:	Fuel injector No.3
★ B2	(F5)	GR/2	:	EVAP canister purge volume control solenoid valve	GR/2	:	Fuel injector No.5
★ E5	(F10)	B/3	:	Crankshaft position sensor (POS)	GR/2	:	Fuel injector No.7
C4	(F21)	GR/1	:	Oil pressure switch	GR/2	:	Fuel injector No.2
E5	(F22)	—	:	Engine ground	GR/2	:	Fuel injector No.4
D5	(F24)	B/1	:	Compressor	GR/2	:	Fuel injector No.6
D5	(F34)	GR/2	:	Compressor	GR/2	:	Fuel injector No.8
E3	(F38)	W/2	:	Condenser			
★ E4	(F39)	B/6	:	Mass air flow sensor			
★ E3	(F42)	G/10	:	A/T assembly			
E5	(F44)	—	:	Engine ground			
★ E2	(F45)	B/6	:	Air fuel ratio (A/F) sensor 1 (Bank 1)			
★ D2	(F46)	B/6	:	Air fuel ratio (A/F) sensor 1 (Bank 2)			
★ D2	(F47)	B/4	:	To (F241)			
★ D5	(F48)	B/3	:	Intake valve timing control position sensor (Bank 1)			
★ B4	(F49)	B/3	:	Intake valve timing control position sensor (Bank 2)			
★ E2	(F50)	SB/2	:	To (F291)			
★ C4	(F53)	B/6	:	Electric throttle control actuator			
★ F5	(F54)	G/4	:	Heated oxygen sensor 2 (Bank 1)			
★ E5	(F55)	L/4	:	Heated oxygen sensor 2 (Bank 2)			
★ D4	(F56)	B/2	:	VIAS control solenoid valve			
★ C5	(F57)	G/2	:	Intake valve timing control solenoid valve (Bank 1)			
★ B4	(F58)	G/2	:	Intake valve timing control solenoid valve (Bank 2)			
E5	(F59)	GR/3	:	Ignition coil No.1 (With power transistor)			
F4	(F60)	GR/3	:	Ignition coil No.3 (With power transistor)			
F4	(F61)	GR/3	:	Ignition coil No.5 (With power transistor)			
F4	(F62)	GR/3	:	Ignition coil No.7 (With power transistor)			
A3	(F63)	GR/3	:	Ignition coil No.2 (With power transistor)			
A3	(F64)	GR/3	:	Ignition coil No.4 (With power transistor)			
B3	(F65)	GR/3	:	Ignition coil No.6 (With power transistor)			
C2	(F66)	GR/3	:	Ignition coil No.8 (With power transistor)			
★ C4	(F67)	B/3	:	Camshaft position sensor (PHASE)			
★ C1	(F68)	B/8	:	To (E73)			

★ C3	(F71)	GR/2	:	Fuel injector No.1
★ C3	(F72)	GR/2	:	Fuel injector No.3
★ D3	(F73)	GR/2	:	Fuel injector No.5
★ D2	(F74)	GR/2	:	Fuel injector No.7
★ B3	(F75)	GR/2	:	Fuel injector No.2
★ B2	(F76)	GR/2	:	Fuel injector No.4
★ C2	(F77)	GR/2	:	Fuel injector No.6
★ C2	(F78)	GR/2	:	Fuel injector No.8

**Engine control sub-harness-1**

★ D2	(F241)	B/4	:	To (F47)
★ C3	(F242)	L/2	:	Knock sensor (Bank 1)
★ C3	(F243)	L/2	:	Knock sensor (Bank 2)

**Engine control sub-harness-2**

★ E2	(F291)	SB/2	:	To (F50)
★ D3	(F292)	GR/2	:	Engine coolant temperature sensor

★ : Be sure to connect and lock the connectors securely after repair work.  
 Failure to do so may cause the ECM to have diagnostic trouble codes.  
 Do not disconnect these connectors except in the case of working according to WORK FLOW of TROUBLE DIAGNOSES in EC and AT sections.

# HARNESS

## Passenger Compartment

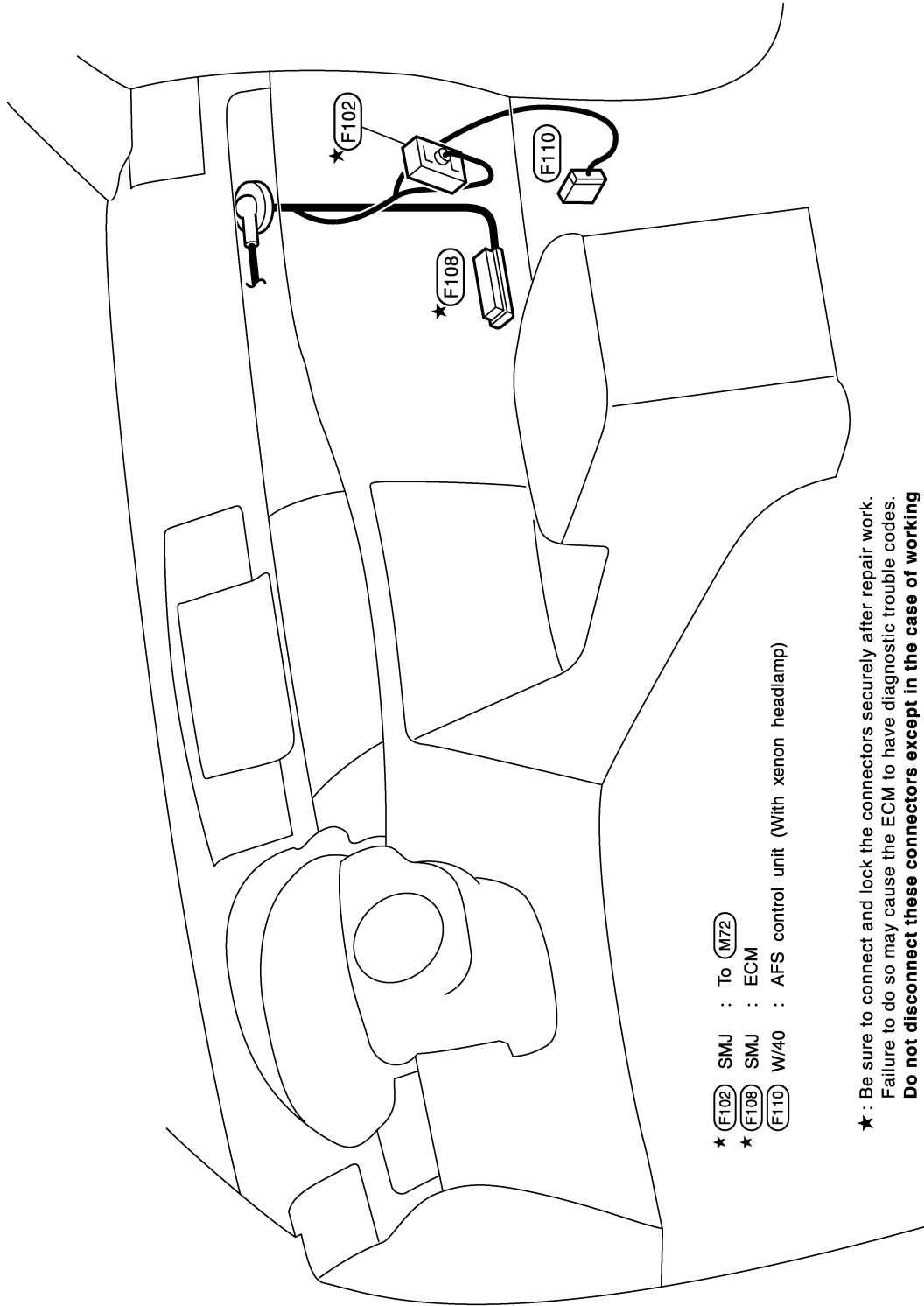

- ★ (F102) SMJ : To (M72)
- ★ (F108) SMJ : ECM
- (F110) W/40 : AFS control unit (With xenon headlamp)

★ : Be sure to connect and lock the connectors securely after repair work.  
Failure to do so may cause the ECM to have diagnostic trouble codes.  
**Do not disconnect these connectors except in the case of working according to WORK FLOW of TROUBLE DIAGNOSES in EC and AT sections.**

TKIT0460E

# HARNESS

## BODY HARNESS

### Passenger Compartment

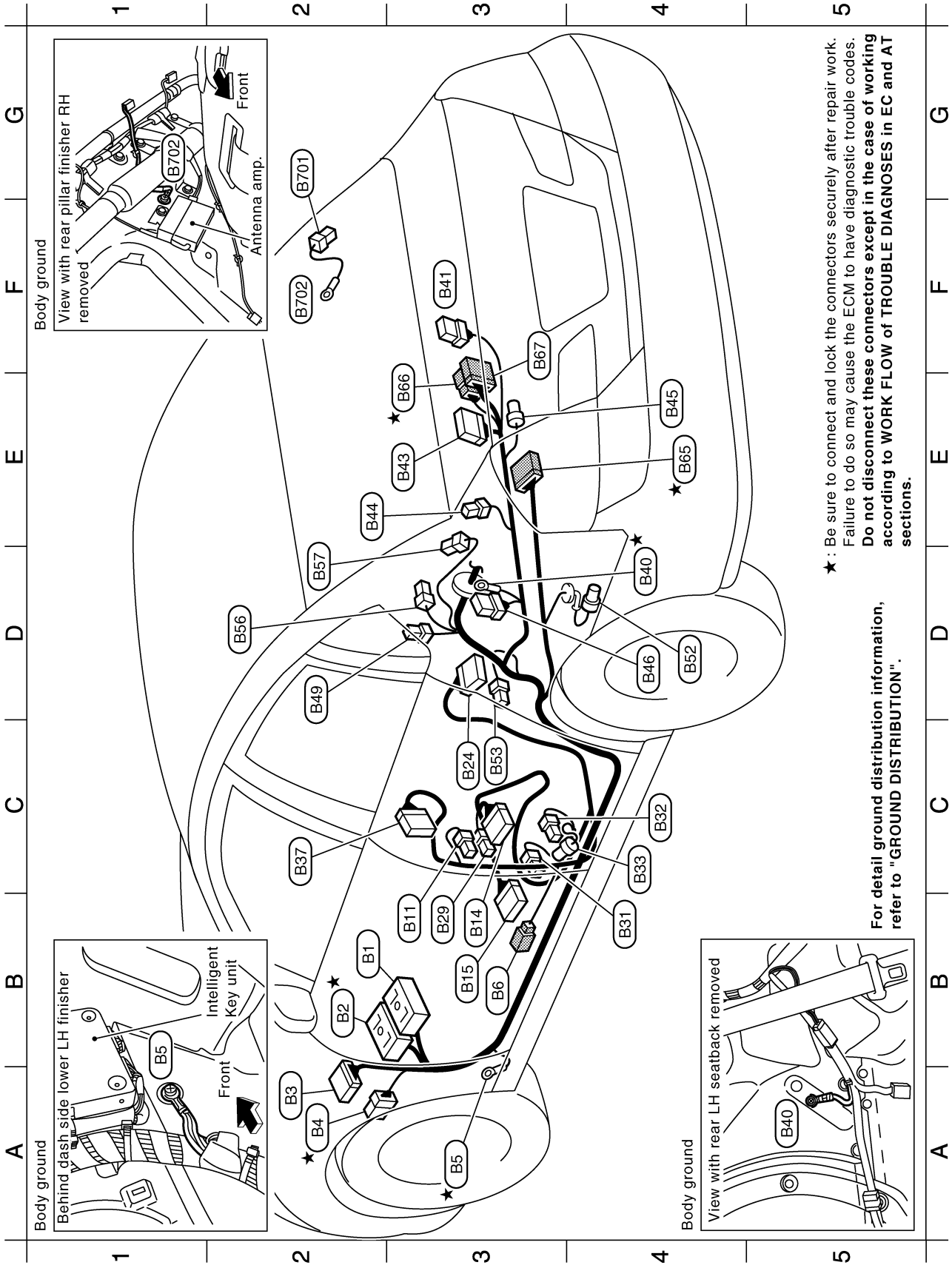

★ : Be sure to connect and lock the connectors securely after repair work. Failure to do so may cause the ECM to have diagnostic trouble codes. Do not disconnect these connectors except in the case of working according to WORK FLOW of TROUBLE DIAGNOSES in EC and AT sections.

For detail ground distribution information, refer to "GROUND DISTRIBUTION".

A B C D E F G H I J K L M N O P Q R S T U V W X Y Z

PG

# HARNESSES

## Body sub-harness

G2 (B701) B/1 : Rear window defogger  
 F2 (B702) — : Body ground

(B1)	SMJ	:	To (M12)
B2★	SMJ	:	To (M13)
A2	W/24	:	To (E105)
A2★	B/8	:	To (E106)
A3★	—	:	Body ground
B3	W/2	:	Kicking plate illumination driver side
B3	W/3	:	Front door switch driver side
B3	W/12	:	Front seat (Driver side)
			[With climate controlled seat or BOSE (5.1ch) system]
B3	W/16	:	Front seat (Driver side)
C3	Y/12	:	Air bag diagnosis sensor unit
B3	B29	:	Front LH side air bag module
B4	Y/2	:	Front LH seat belt pre-tensioner
C4	B32	:	Pre-crash seat belt motor LH
C4	B33	:	LH side air bag (satellite) sensor
C2	W/18	:	To (D51)
D4★	—	:	Body ground
F3	W/6	:	Rear seat RH (With rear power seat)
E3	W/10	:	Rear seat armrest RH (With rear power seat)
E2	B44	:	Rear seat armrest LH (With rear power seat)
E4	B45	:	Inside key antenna (Rear seat)
D4	B46	:	Rear seat LH (With rear power seat)
D2	B49	:	Condenser
D4	B52	:	Fuel level sensor unit (Sub)
C3	B53	:	Rear door switch LH
D2	B56	:	High-mounted stop lamp (Via sub-harness)
D2	B57	:	LH side curtain air bag module
E4★	B65	:	To (B434)
E3★	B66	:	To (B436)
F3	BRI/24	:	To (B437)

★ : Be sure to connect and lock the connectors securely after repair work.  
 Failure to do so may cause the ECM to have diagnostic trouble codes.  
 Do not disconnect these connectors except in the case of working according to WORK FLOW of TROUBLE DIAGNOSES in EC and AT sections.

# HARNESS

## Luggage Compartment

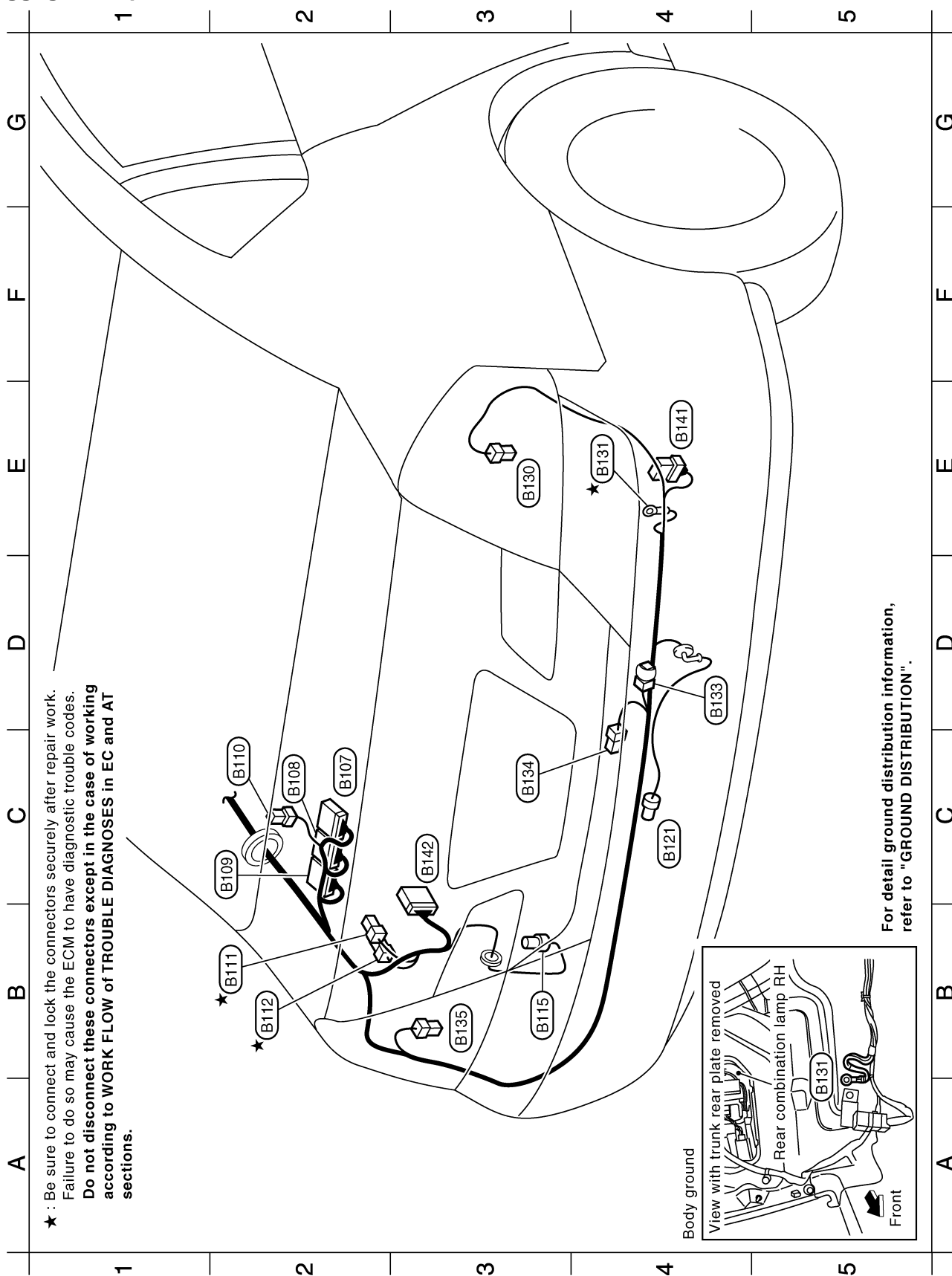

A  
B  
C  
D  
E  
F  
G  
H  
I  
J  
K  
L  
M  
N  
O  
P  
Q  
R  
S  
T  
U  
V  
W  
X  
Y  
Z  
PG

TKIT0764E

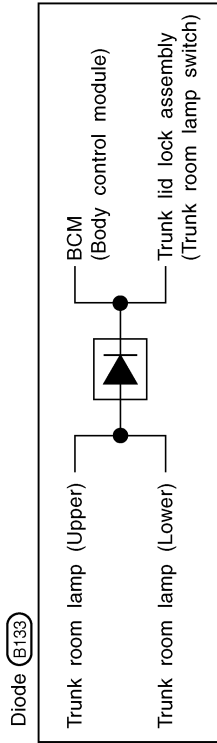

C2	(B107)	W/40	:	BOSE amp. (With BOSE system)
C2	(B108)	BR/14	:	BOSE amp. (With BOSE system)
C2	(B109)	BR/23	:	BOSE amp. (With BOSE system)
C2	(B110)	BR/2	:	Rear surround speaker LH (With BOSE system)
B2	★ (B111)	W/4	:	Fuel pump control module
B2	★ (B112)	W/2	:	Dropping resistor
B3	(B115)	B/4	:	Tire pressure receiver rear LH
C4	(B121)	GR/2	:	Outside key antenna (Trunk room)
E3	(B130)	W/4	:	Rear combination lamp RH
E4	★ (B131)	—	:	Body ground
D4	(B133)	W/2	:	Diode
C3	(B134)	W/2	:	Trunk room lamp (Lower)
B3	(B135)	W/4	:	Rear combination lamp LH
E4	(B141)	BR/6	:	Rear sunshade cancel relay
C3	(B142)	W/26	:	Pre-crash seat belt control unit

★ : Be sure to connect and lock the connectors securely after repair work.  
 Failure to do so may cause the ECM to have diagnostic trouble codes.  
 Do not disconnect these connectors except in the case of working according to WORK FLOW of TROUBLE DIAGNOSES in EC and AT sections.

# HARNESS

## BODY NO. 2 HARNESS Passenger Compartment

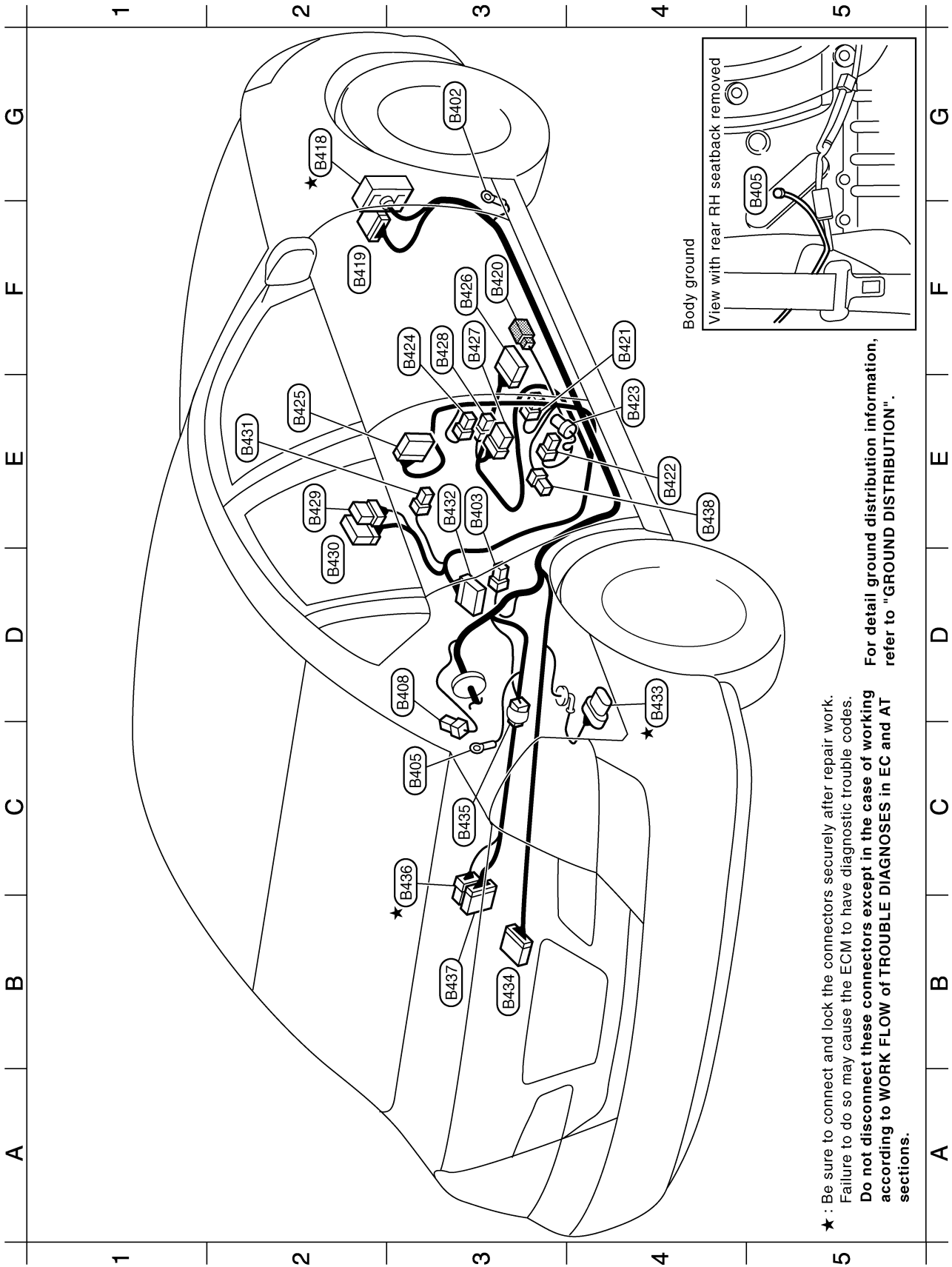

★ : Be sure to connect and lock the connectors securely after repair work.  
 Failure to do so may cause the ECM to have diagnostic trouble codes.  
 Do not disconnect these connectors except in the case of working  
 according to WORK FLOW of TROUBLE DIAGNOSES in EC and AT  
 sections.

For detail ground distribution information,  
 refer to "GROUND DISTRIBUTION".

TKIT0766E

A  
B  
C  
D  
E  
F  
G  
H  
I  
J  
K  
L  
M  
N  
O  
P  
Q  
R  
S  
T  
U  
V  
W  
X  
Y  
Z

PG

# HARNESSES

G3	(B402)	—	:	Body ground
E3	(B403)	W/3	:	Rear door switch RH
C3	(B405)	—	:	Body ground
D3	(B408)	Y/2	:	RH side curtain air bag module
G2	(B418)★	SMJ	:	To (M66)
F2	(B419)	W/32	:	To (M218)
F3	(B420)	W/2	:	Kicking plate illumination passenger side
F4	(B421)	Y/2	:	Front RH seat belt pre-tensioner
E4	(B422)	W/2	:	Pre-crash seat belt motor RH
E4	(B423)	Y/2	:	RH side air bag (satellite) sensor
F3	(B424)	W/3	:	Front door switch passenger side
E2	(B425)	W/18	:	To (D71)
F3	(B426)	W/18	:	Front seat (Passenger side)
F3	(B427)	W/8	:	Front seat (Passenger side)
F3	(B428)	Y/2	:	Front RH side air bag module
E2	(B429)	BR/8	:	Climate controlled seat switch passenger side
D2	(B430)	W/10	:	Climate controlled seat switch driver side
E2	(B431)	W/4	:	To (M153) (For rear view monitor)
E3	(B432)	Y/12	:	Air bag diagnosis sensor unit
D4	(B433)★	GR/5	:	Fuel level sensor unit and fuel pump
B3	(B434)	W/16	:	To (E66)
C3	(B435)	W/2	:	Condenser
C3	(B436)★	B/8	:	To (E66)
B3	(B437)	BR/24	:	To (E67)
E4	(B438)	W/3	:	Belt tension sensor

★ : Be sure to connect and lock the connectors securely after repair work.  
 Failure to do so may cause the ECM to have diagnostic trouble codes.  
**Do not disconnect these connectors except in the case of working according to WORK FLOW of TROUBLE DIAGNOSES in EC and AT sections.**

TKIT0767E



# HARNESS

## Luggage Compartment

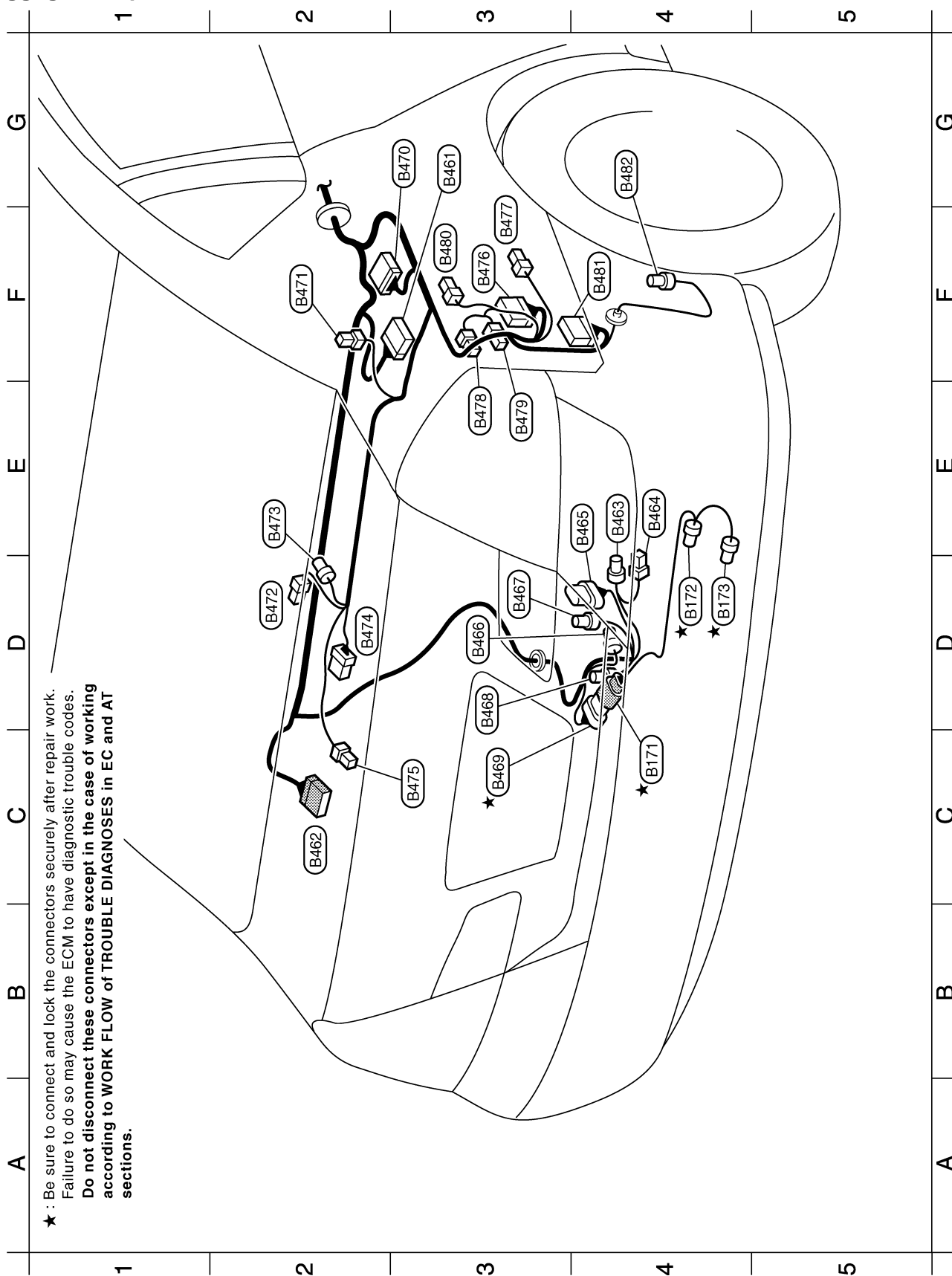

A  
B  
C  
D  
E  
F  
G  
H  
I  
J  
K  
L  
M  
N  
O  
P  
Q  
R  
S  
T  
U  
V  
W  
X  
Y  
Z

PG

TKIT0768E

# HARNESS

## EVAP sub-harness

C4	★	(B171)	B/6	:	To	(E469)
D4	★	(B172)	GR/3	:	EVAP control system pressure sensor	
D4	★	(B173)	B/2	:	EVAP canister vent control valve	
G3		(E461)	W/16	:	Satellite radio tuner	
C2		(E462)	W/20	:	To (E105) (With rear display)	
E4		(E463)	B/2	:	RAS motor (With RAS)	
E4		(E464)	B/1	:	Body ground (With RAS)	
E4		(E465)	GR/6	:	Rear wheel steering angle sensor (With RAS)	
D3		(E466)	B/2	:	Rear wheel sensor RH	
D3		(E467)	B/2	:	Rear wheel sensor LH	
D3		(E468)	B/3	:	Height sensor	
C3		(E469)	B/6	:	To (E171)	
G3		(E470)	W/12	:	To (T1)	
F2		(E471)	BR/2	:	Rear surround speaker RH (With BOSE system)	
D2		(E472)	W/2	:	Woofers (With BOSE system)	
E2		(E473)	GR/2	:	Inside key antenna (Trunk room)	
D2		(E474)	W/8	:	Rear sunshade unit (With built-in motor)	
C3		(E475)	W/2	:	Trunk room lamp (Upper)	
F3		(E476)	W/40	:	RAS control unit (With RAS)	
F3		(E477)	W/4	:	Fuel lid lock actuator	
E3		(E478)	W/2	:	Noise Suppressor (With RAS)	
E3		(E479)	W/3	:	Noise Suppressor (With RAS)	
F3		(E480)	L/4	:	RAS motor relay (With RAS)	
F4		(E481)	W/32	:	Camera control unit	
G4		(E482)	B/4	:	Tire pressure receiver rear RH	

★ : Be sure to connect and lock the connectors securely after repair work.  
 Failure to do so may cause the ECM to have diagnostic trouble codes.  
 Do not disconnect these connectors except in the case of working  
 according to WORK FLOW of TROUBLE DIAGNOSES in EC and AT  
 sections.

TKIT0769E

# HARNESS

## TAIL HARNESS

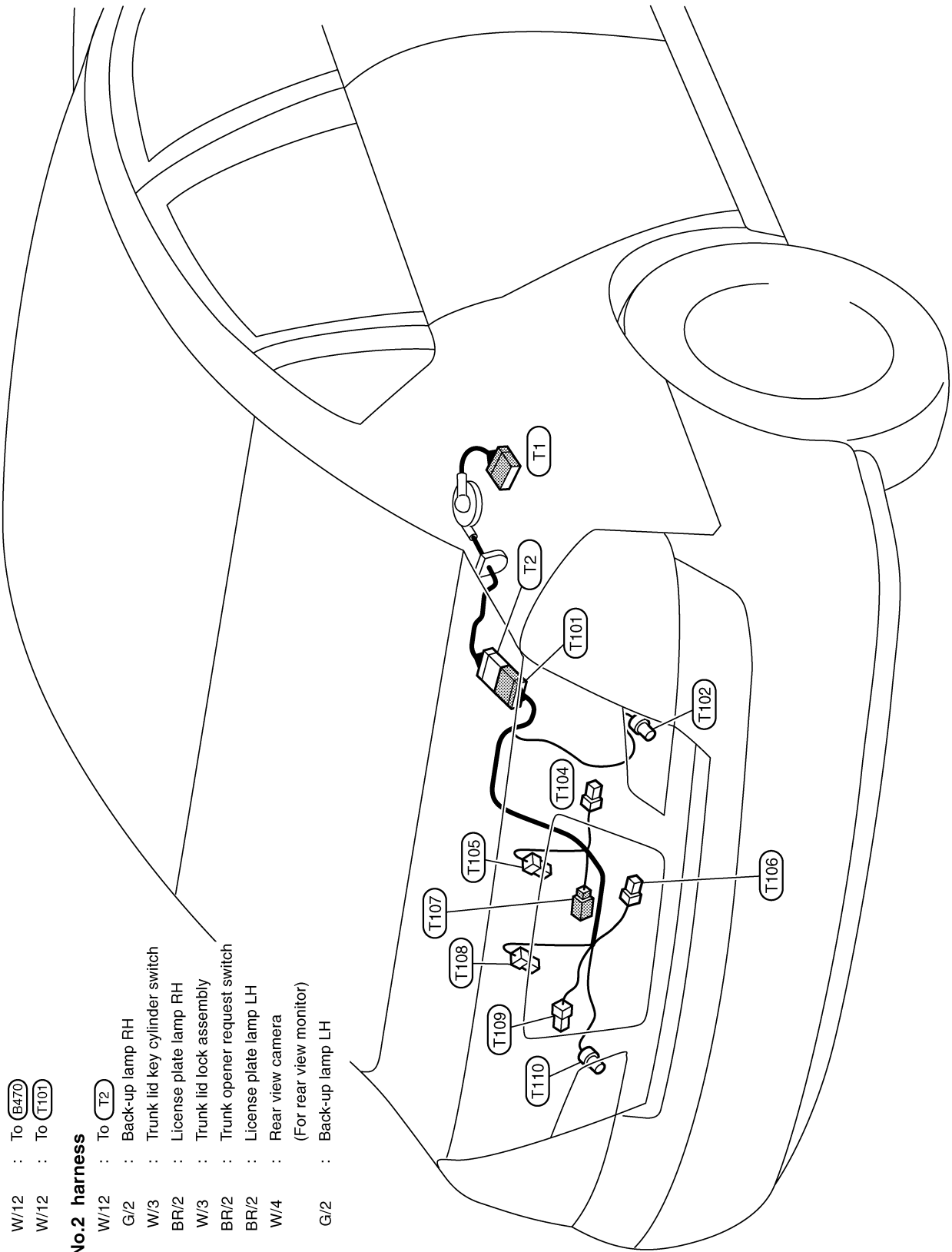

W/12 : To (B47D)  
 W/12 : To (T101)

**Tail No.2 harness**

(T1) (T2) (T101) (T102) (T104) (T105) (T106) (T107) (T108) (T109) (T110)

W/12 : To (T2)  
 G/2 : Back-up lamp RH  
 W/3 : Trunk lid key cylinder switch  
 BR/2 : License plate lamp RH  
 W/3 : Trunk lid lock assembly  
 BR/2 : Trunk opener request switch  
 BR/2 : License plate lamp LH  
 W/4 : Rear view camera  
 (For rear view monitor)  
 G/2 : Back-up lamp LH

A  
 B  
 C  
 D  
 E  
 F  
 G  
 H  
 I  
 J  
 PG  
 L  
 M

TKIT0770E

# HARNESS

## ROOM LAMP HARNESS



### Room lamp harness

- R51 : To (M181) W/24
- R52 : Microphone W/4
- R53 : Sunroof switch W/3
- R54 : Map lamp W/8
- R55 : Personal lamp RH W/3
- R57 : Personal lamp LH W/3
- R59 : Front passenger air bag off indicator W/3

### Rear display harness

- R101 : To (M232) W/12
- R102 : Rear display unit W/24
- R103 : HeadPHONE amp. W/12
- R104 : HeadPHONE amp. (Remote control receiver) W/4
- R105 : To (E462) W/20

TKIT0771E

# HARNESS

## FRONT DOOR HARNESS

### LH Side

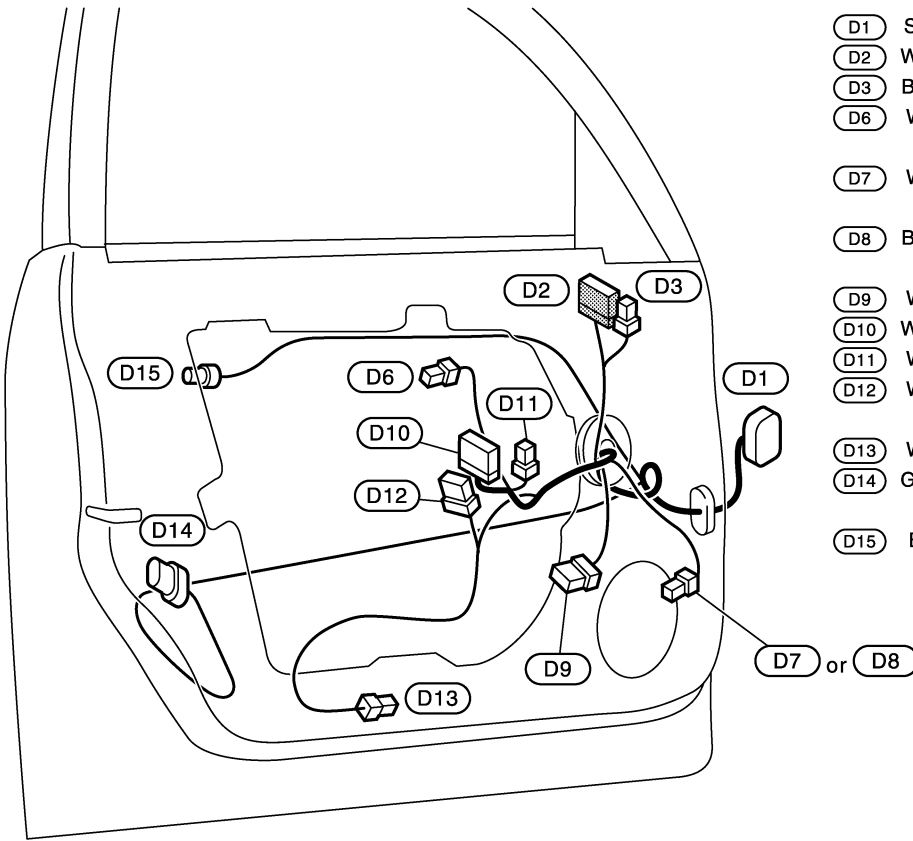

- (D1) SMJ : To (M11)
- (D2) W/12 : Door mirror LH
- (D3) BR/2 : Tweeter LH
- (D6) W/2 : Power window main switch illumination
- (D7) W/2 : Front door speaker LH (Without BOSE system)
- (D8) BR/2 : Front door speaker LH (With BOSE system)
- (D9) W/8 : Seat memory switch
- (D10) W/16 : Power window main switch
- (D11) W/3 : Power window main switch
- (D12) W/6 : Power window motor (Driver side)
- (D13) W/2 : Step lamp (Driver side)
- (D14) GR/6 : Front door lock assembly (Driver side)
- (D15) B/4 : Front outside handle LH

TKIT0468E

### RH Side

- (D31) SMJ : To (M74)
- (D33) BR/2 : Tweeter RH
- (D37) W/2 : Front door speaker RH (Without BOSE system)
- (D38) BR/2 : Front door speaker RH (With BOSE system)
- (D39) W/12 : Door mirror RH
- (D42) W/6 : Power window motor (Front passenger side)
- (D43) W/2 : Step lamp (Front passenger side)
- (D44) GR/6 : Front door lock actuator passenger side
- (D45) B/4 : Front outside handle RH
- (D46) W/16 : Power window sub-switch (Front passenger side)

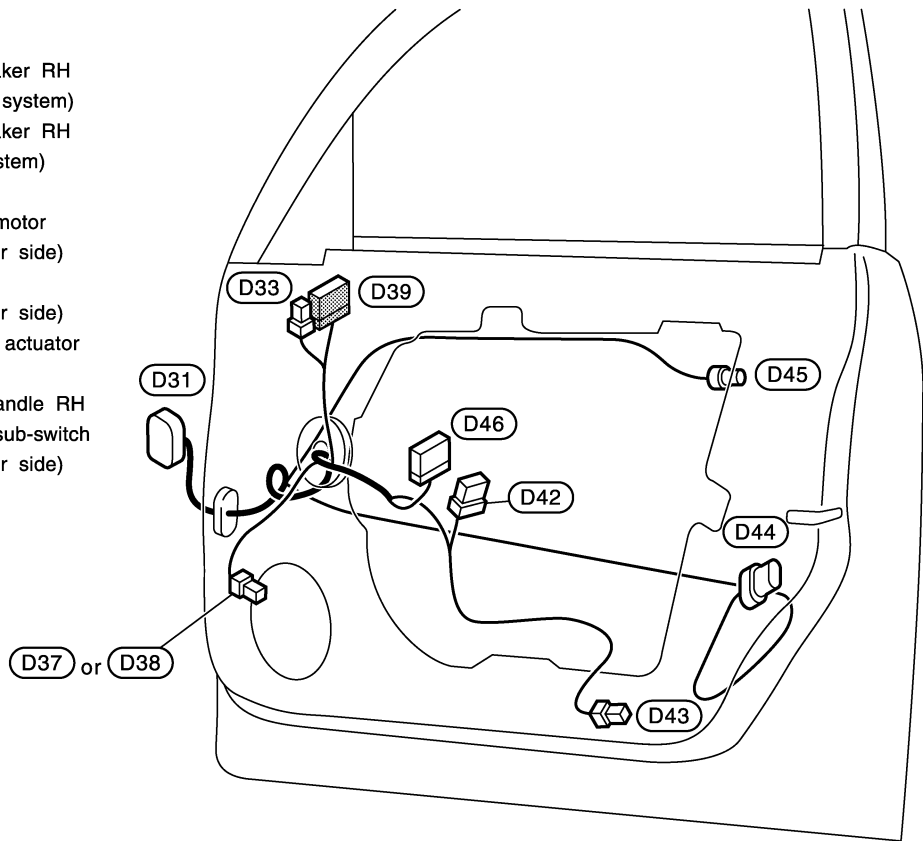

TKIT0469E

A  
B  
C  
D  
E  
F  
G  
H  
I  
J  
PG  
L  
M

# HARNESS

## REAR DOOR HARNESS

### LH Side

- (D51) W/18 : To (B37)
- (D52) W/2 : Rear door speaker LH (Without BOSE system)
- (D53) BR/2 : Rear door speaker LH (With BOSE system)
- (D54) W/2 : Step lamp (Rear LH)
- (D56) W/3 : Ashtray illumination (Rear LH)
- (D58) W/6 : Power window motor (Rear LH)
- (D59) GR/6 : Rear door lock actuator LH
- (D60) W/16 : Power window sub-switch (Rear LH)

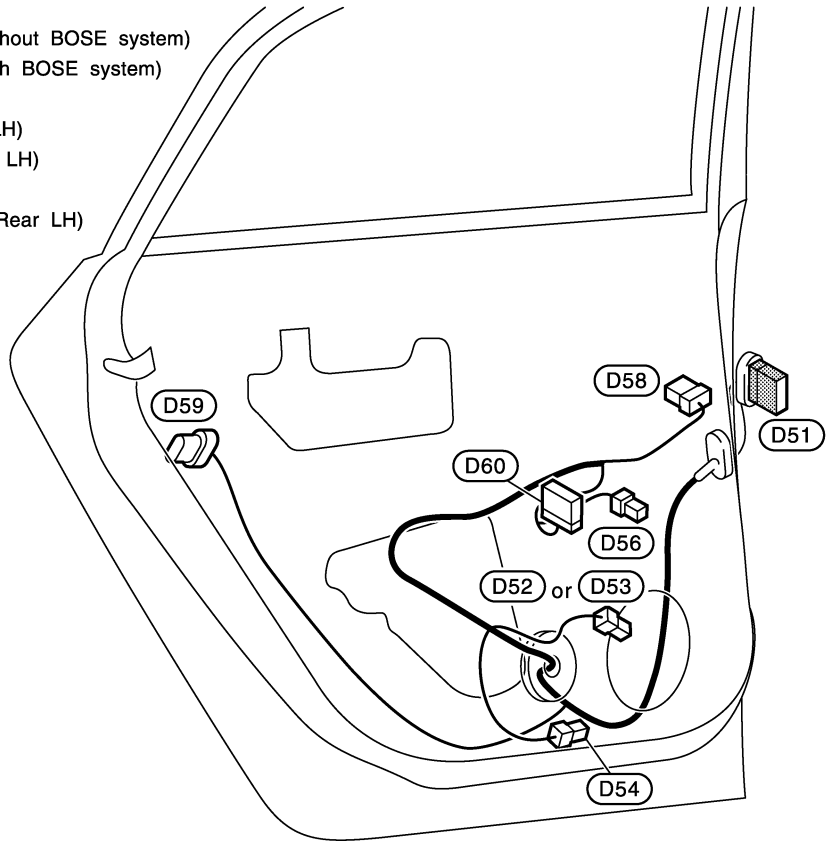

TKIT0470E

### RH Side

- (D71) W/18 : To (B425)
- (D72) W/2 : Rear door speaker RH (Without BOSE system)
- (D73) BR/2 : Rear door speaker RH (With BOSE system)
- (D74) W/2 : Step lamp (Rear RH)
- (D76) W/3 : Ashtray illumination (Rear RH)
- (D78) W/6 : Power window motor (Rear RH)
- (D79) GR/6 : Rear door lock actuator RH
- (D80) W/16 : Power window sub-switch (Rear RH)

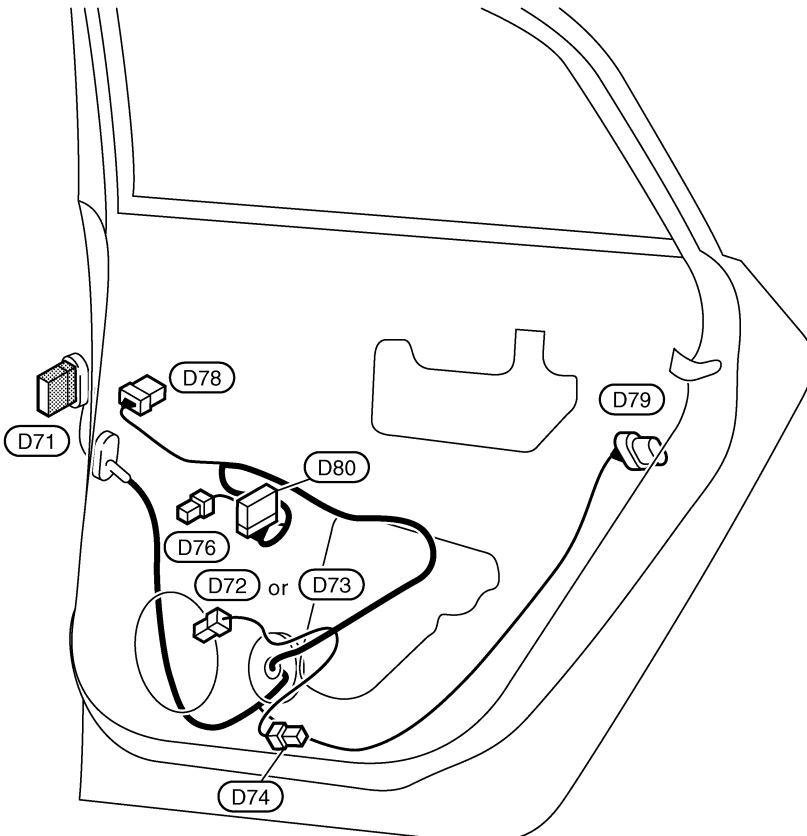

TKIT0772E

# HARNESS

## Wiring Diagram Codes (Cell Codes)

NKS004ET

Use the chart below to find out what each wiring diagram code stands for. Refer to the wiring diagram code in the alphabetical index to find the location (page number) of each wiring diagram.

Code	Section	Wiring Diagram Name
A/C	ATC	Air Conditioner
AF1B1	EC	Air Fuel Ratio Sensor 1 Bank 1
AF1B2	EC	Air Fuel Ratio Sensor 1 Bank 2
AF1HB1	EC	Air Fuel Ratio Sensor 1 Heater Bank 1
AF1HB2	EC	Air Fuel Ratio Sensor 1 Heater Bank 2
AFS	LT	Adaptive Front Lighting System
APPS1	EC	Accelerator Pedal Position Sensor
APPS2	EC	Accelerator Pedal Position Sensor
APPS3	EC	Accelerator Pedal Position Sensor
ASC/BS	EC	Automatic Speed Control Device (ASCD) Brake Switch
ASC/SW	EC	Automatic Speed Control Device (ASCD) Steering Switch
ASCBOF	EC	Automatic Speed Control Device (ASCD) Brake Switch
ASCIND	EC	Automatic Speed Control Device (ASCD) Indicator
AT/IND	DI	A/T Indicator Lamp
AUT/DP	SE	Automatic Drive Positioner
AUTO/L	LT	Automatic Light System
AV	AV	Audio and Visual System
AWD	TF	AWD Control System
BACK/L	LT	Back-Up Lamp
BRK/SW	EC	Brake Switch
C/SEAT	SE	Climate Controlled Seat
CAN	AT	CAN Communication Line
CAN	EC	CAN Communication Line
CAN	LAN	CAN System
CHARGE	SC	Charging System
CHIME	DI	Warning Chime
CIGAR	WW	Cigarette Lighter
CLOCK	DI	Clock
COMBSW	LT	Combination Switch
COMPAS	DI	Compass and Thermometer
COOL/F	EC	Cooling Fan Control
CUR/SE	EC	Battery Current Sensor
D/LOCK	BL	Power Door Lock
DEF	GW	Rear Window Defogger
DTRL	LT	Headlamp - with Daytime Light System
ECM/PW	EC	ECM Power Supply for Back-Up
ECTS	EC	Engine Coolant Temperature Sensor
ENG/ST	BL	Engine Start System
EPS	STC	Electric Controlled Power Steering System
ETC1	EC	Electric Throttle Control Function
ETC2	EC	Electric Throttle Control Motor Relay

# HARNESSES

Code	Section	Wiring Diagram Name
ETC3	EC	Electric Throttle Control Motor
F/FOG	LT	Front Fog Lamp
F/PUMP	EC	Fuel Pump
FPCM	EC	Fuel Pump Control Module
FTS	AT	A/T Fluid Temperature Sensor Circuit
FTTS	EC	Fuel Tank Temperature Sensor
FUELB1	EC	Fuel Injection System Function (Bank 1)
FUELB2	EC	Fuel Injection System Function (Bank 2)
H/LAMP	LT	Headlamp
HORN	WW	Horn
HSEAT	SE	Heated Seat
I/KEY	BL	Intelligent Key System
I/MIRR	GW	Inside Mirror (Auto Anti-Dazzling Mirror)
IATS	EC	Intake Air Temperature Sensor
ICC	ACS	Intelligent Cruise Control System
ICC/BS	EC	ICC Brake Switch
ICC/SW	EC	ICC Steering Switch
ICCBOF	EC	ICC Brake Switch
IGNSYS	EC	Ignition System
ILL	LT	Illumination
INJECT	EC	Injector
IVCB1	EC	Intake Valve Timing Control Solenoid Valve Bank 1
IVCB2	EC	Intake Valve Timing Control Solenoid Valve Bank 2
IVCSB1	EC	Intake Valve Timing Control Position Sensor Bank 1
IVCSB2	EC	Intake Valve Timing Control Position Sensor Bank 2
IVTB1	EC	Intake Valve Timing Control System (Bank 1)
IVTB2	EC	Intake Valve Timing Control System (Bank 2)
KS	EC	Knock Sensor
LDW	DI	Lane Departure Warning System
MAFS	EC	Mass Air Flow Sensor
MAIN	AT	Main Power Supply and Ground Circuit
MAIN	EC	Main Power Supply and Ground Circuit
METER	DI	Speedometer, Tachometer, Temp., Oil and Fuel Gauges
MIL/DL	EC	MIL & Data Link Connector
MIRROR	GW	Door Mirror
MMSW	AT	Manual Mode Switch
NATS	BL	Nissan Anti-Theft System
NONDTC	AT	Non-Detective Items
O2H2B1	EC	Heated Oxygen Sensor 2 Heater Bank 1
O2H2B2	EC	Heated Oxygen Sensor 2 Heater Bank 2
O2S2B1	EC	Heated Oxygen Sensor 2 Bank 1
O2S2B2	EC	Heated Oxygen Sensor 2 Bank 2
P/SCKT	WW	Power Socket
PDU	PG	Power Distribution Unit



# HARNESS

Code	Section	Wiring Diagram Name
PGC/V	EC	EVAP Canister Purge Volume Control Solenoid Valve
PHASE	EC	Camshaft Position Sensor (PHASE)
PHSB1	EC	Camshaft Position Sensor (PHASE) (Bank 1)
PHSB2	EC	Camshaft Position Sensor (PHASE) (Bank 2)
PNP/SW	AT	Park/Neutral Position Switch
PNP/SW	EC	Park/Neutral Position Switch
POS	EC	Crankshaft Position Sensor (CKPS) (POS)
POWER	PG	Power Supply Routing Circuit
PRE/SE	EC	EVAP Control System Pressure Sensor
PS/SEN	EC	Power Steering Pressure Sensor
PSB	SB	Pre-Crash Seat Belt
R/SEAT	SE	Auto Return Seat
RAS	STC	Rear Active Steer
ROOM/L	LT	Interior Room Lamp
RP/SEN	EC	Refrigerant Pressure Sensor
SEAT	SE	Power Seat
SEN/PW	EC	Sensor Power Supply
SHADE	EI	Rear Sunshade
SHIFT	AT	A/T Shift Lock System
SNOWSW	EC	Snow Mode Switch
SROOF	RF	Sunroof
SRS	SRS	Supplemental Restraint System
START	SC	Starting System
STOP/L	LT	Stop Lamp
STSIG	AT	Start Signal Circuit
T/WARN	WT	Low Tire Pressure Warning System
TAIL/L	LT	Parking, License and Tail Lamps
TLID	BL	Trunk Lid Opener
TPS1	EC	Throttle Position Sensor (Sensor 1)
TPS2	EC	Throttle Position Sensor (Sensor 2)
TPS3	EC	Throttle Position Sensor
TRNSCV	BL	Homelink Universal Transceiver
TURN	LT	Turn Signal and Hazard Warning Lamp
VDC	BRC	Vehicle Dynamics Control System
VEHSEC	BL	Vehicle Security System
VENT/V	EC	EVAP Canister Vent Control Valve
VIAS	EC	Variable Induction Air Control System
VIAS/V	EC	VIAS Control Solenoid Valve
VSSAT	AT	Vehicle speed Sensor A/T (Revolution Sensor)
WARN	DI	Warning Lamps
WINDOW	GW	Power Window
WIPER	WW	Front Wiper and Washer

A  
B  
C  
D  
E  
F  
G  
H  
I  
J  
L  
M

PG

# ELECTRICAL UNITS LOCATION

PFP:25230

## ELECTRICAL UNITS LOCATION

### Electrical Units Location ENGINE COMPARTMENT

NKS004EU

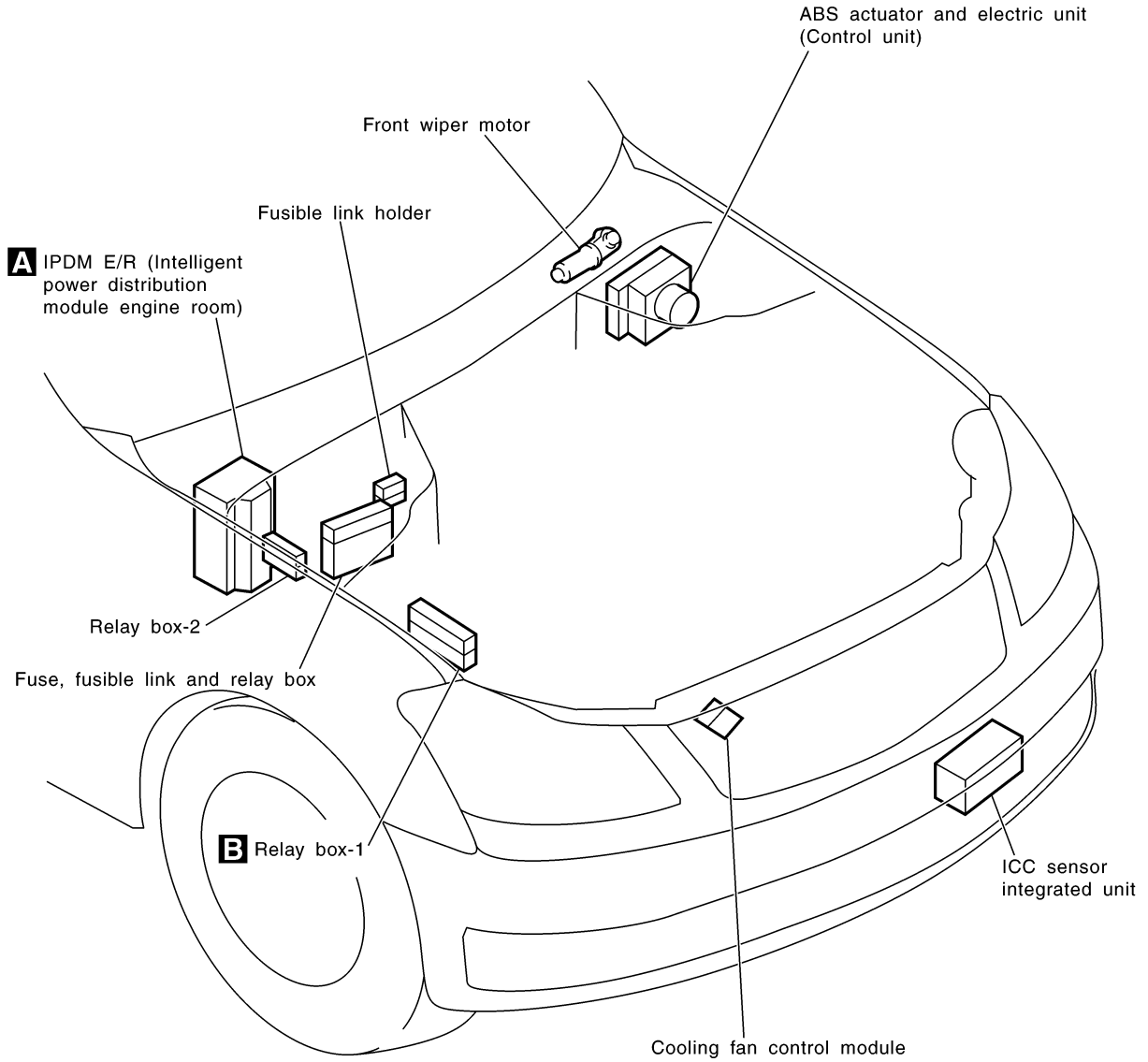

# ELECTRICAL UNITS LOCATION

**A**

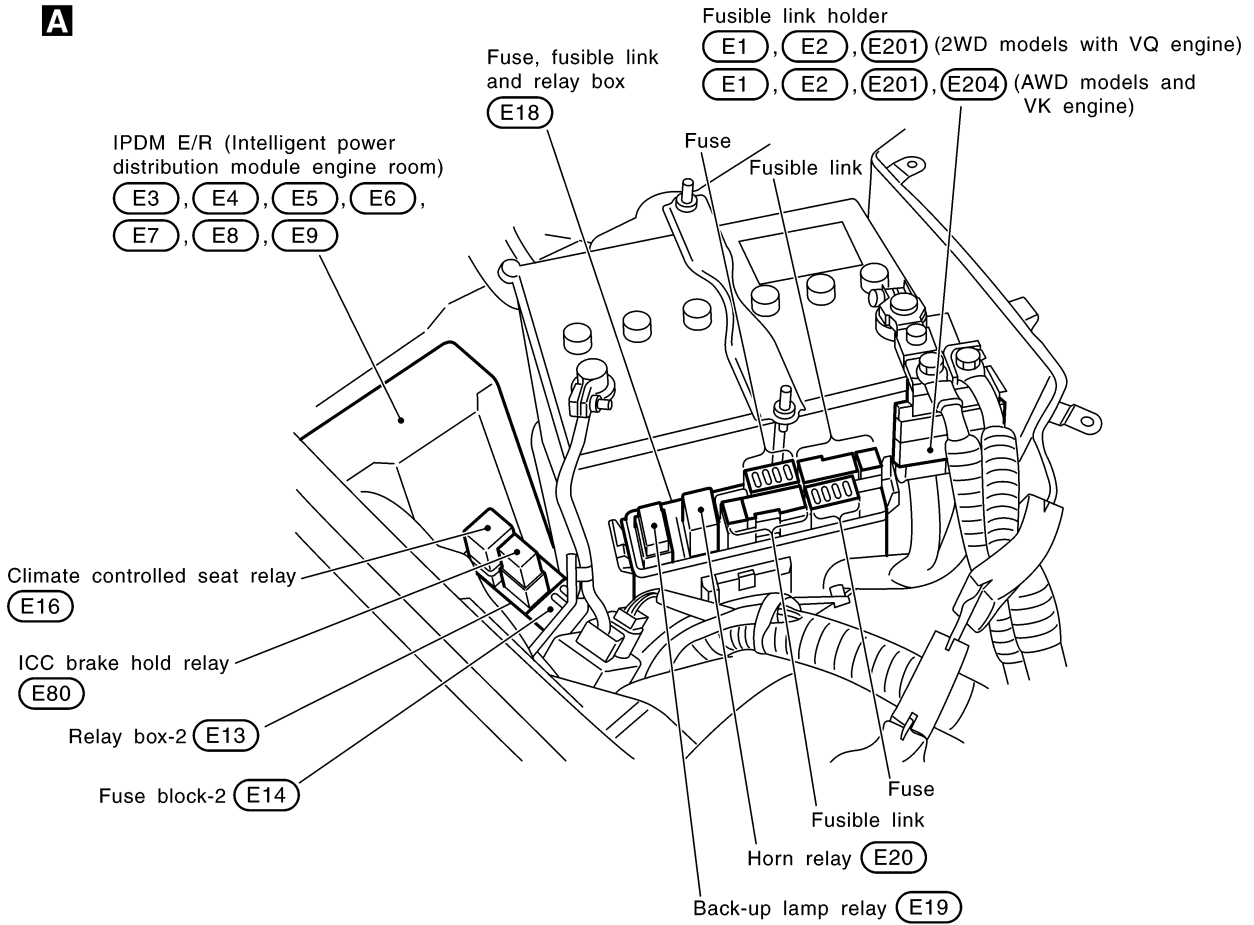

**B**

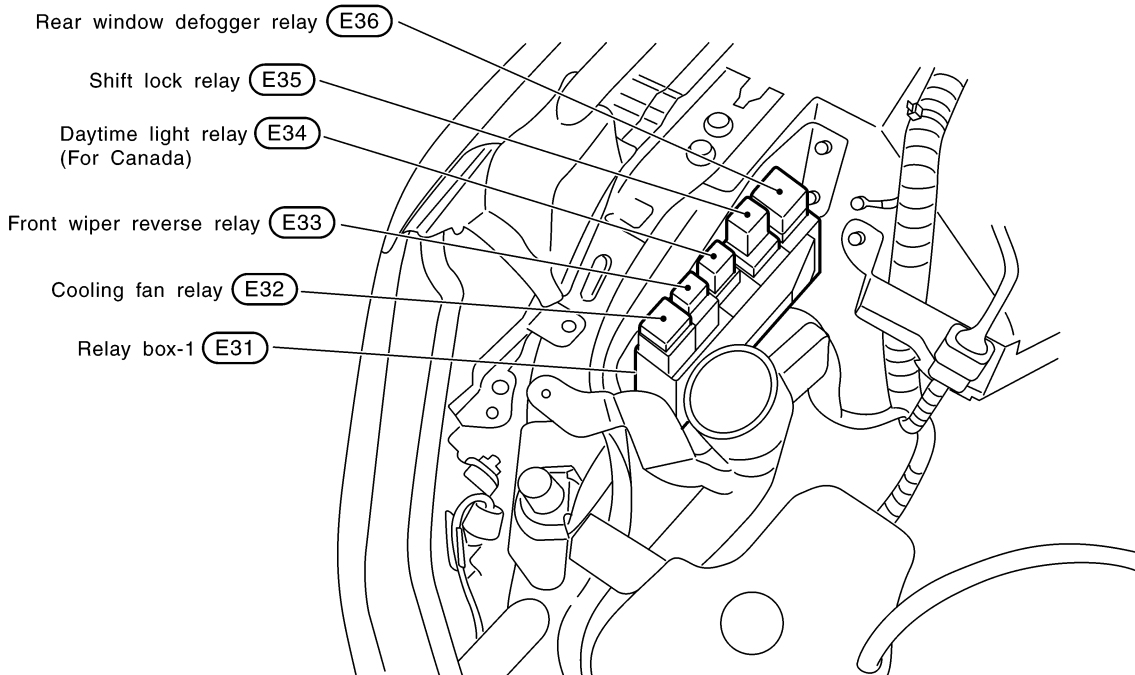

CKIT0656E

A  
B  
C  
D  
E  
F  
G  
H  
I  
J  
L  
M

PG

# ELECTRICAL UNITS LOCATION

## PASSENGER COMPARTMENT

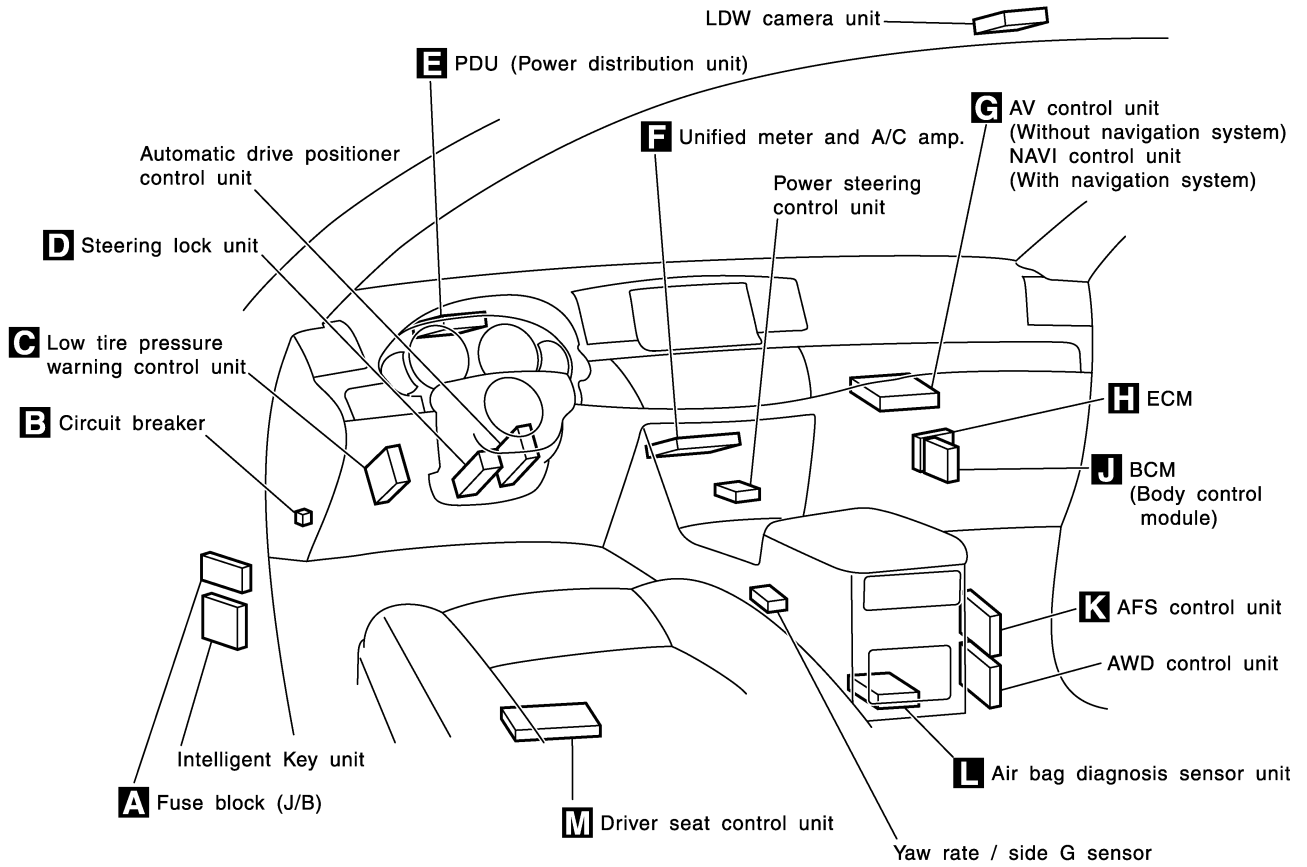

**A** Behind dash side lower LH finisher

Fuse block (J/B) rear view

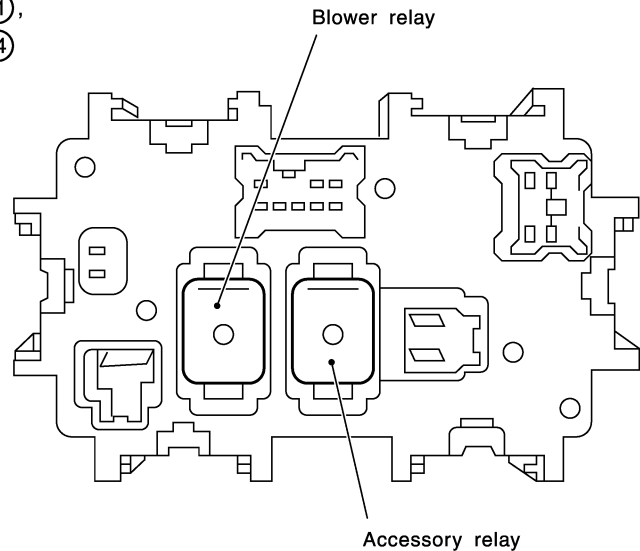
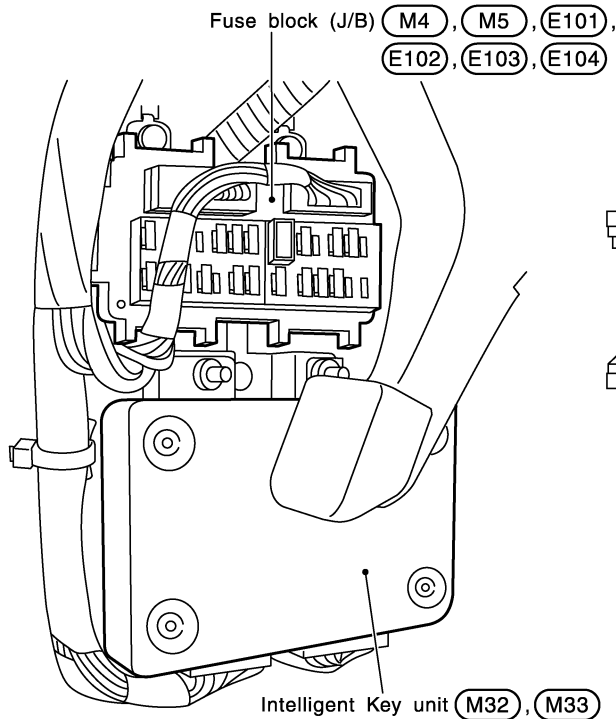

CKIT0657E

# ELECTRICAL UNITS LOCATION

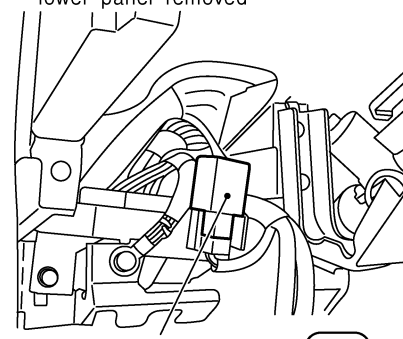
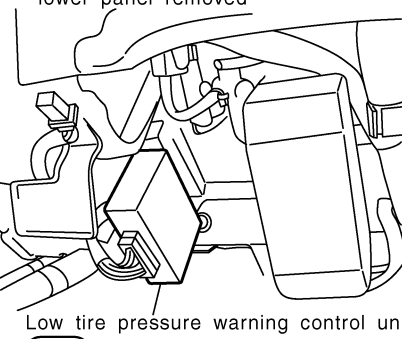
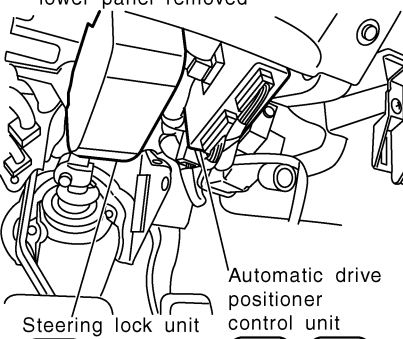
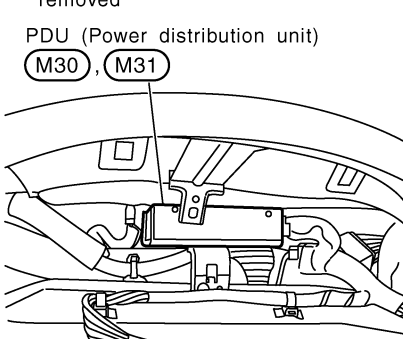
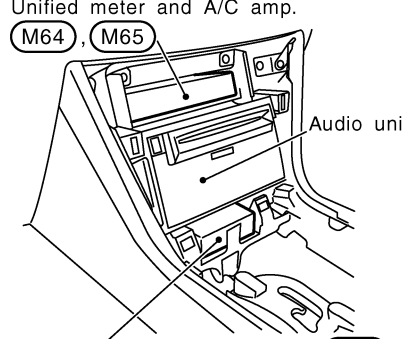
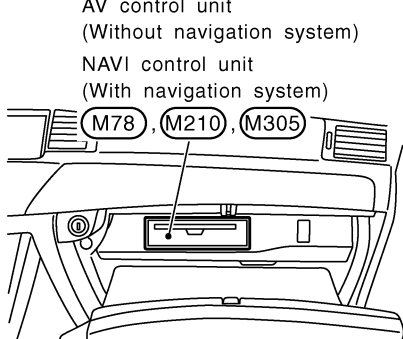
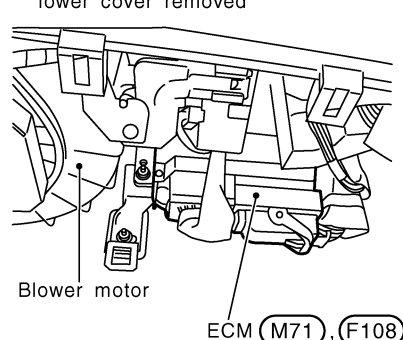
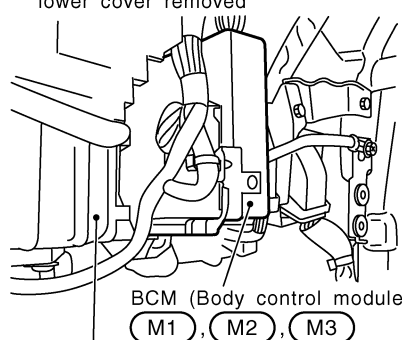
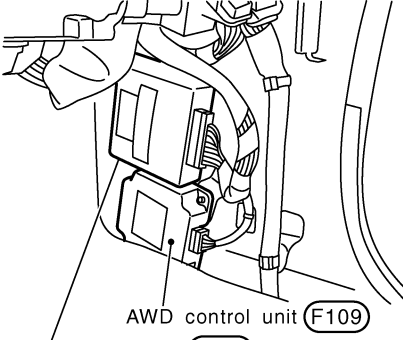
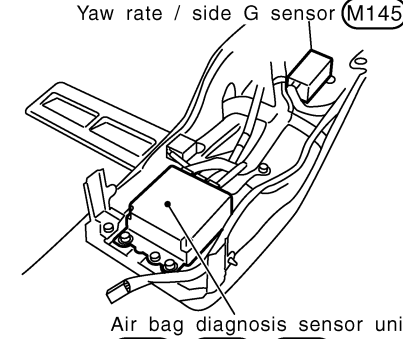
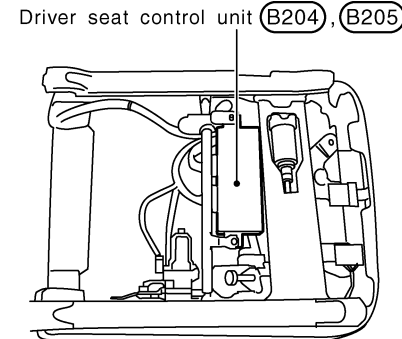
<p><b>B</b> Driver side view with instrument lower panel removed</p>  <p>Circuit breaker (M26)</p>	<p><b>C</b> Driver side view with instrument lower panel removed</p>  <p>Low tire pressure warning control unit (M19)</p>	<p><b>D</b> Driver side view with instrument lower panel removed</p>  <p>Steering lock unit (M35)</p> <p>Automatic drive positioner control unit (M6, M7)</p>
<p><b>E</b> View with combination meter removed</p> <p>PDU (Power distribution unit) (M30, M31)</p> 	<p><b>F</b> View with cluster lid C removed</p> <p>Unified meter and A/C amp. (M64, M65)</p> <p>Audio unit</p> <p>Power steering control unit (M8)</p> 	<p><b>G</b> Inside of glove box</p> <p>AV control unit (Without navigation system)</p> <p>NAVI control unit (With navigation system) (M78, M210, M305)</p> 
<p><b>H</b> Passenger side view with instrument lower cover removed</p>  <p>Blower motor</p> <p>ECM (M71, F108)</p>	<p><b>J</b> Passenger side view with instrument lower cover removed</p>  <p>BCM (Body control module) (M1, M2, M3)</p> <p>Blower motor</p>	<p><b>K</b> Behind dash side lower RH finisher</p>  <p>AWD control unit (F109)</p> <p>AFS control unit (F110)</p>
<p><b>L</b> View with floor console box removed</p> <p>Yaw rate / side G sensor (M145)</p>  <p>Air bag diagnosis sensor unit (M147, B24, B432)</p>	<p><b>M</b> Under driver's seat</p> <p>Driver seat control unit (B204, B205)</p> 	

A  
B  
C  
D  
E  
F  
G  
H  
I  
J  
L  
M

PG

CKIT0819E

# ELECTRICAL UNITS LOCATION

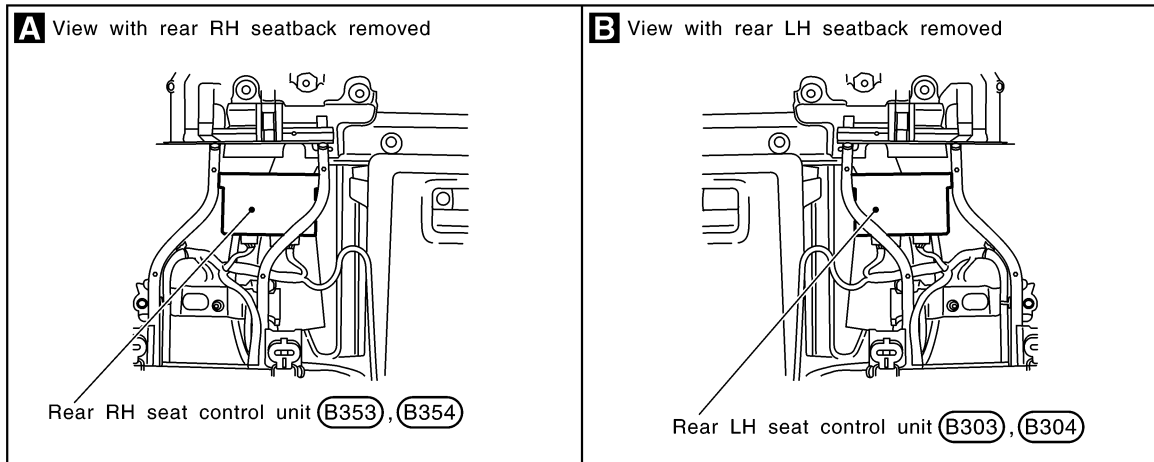
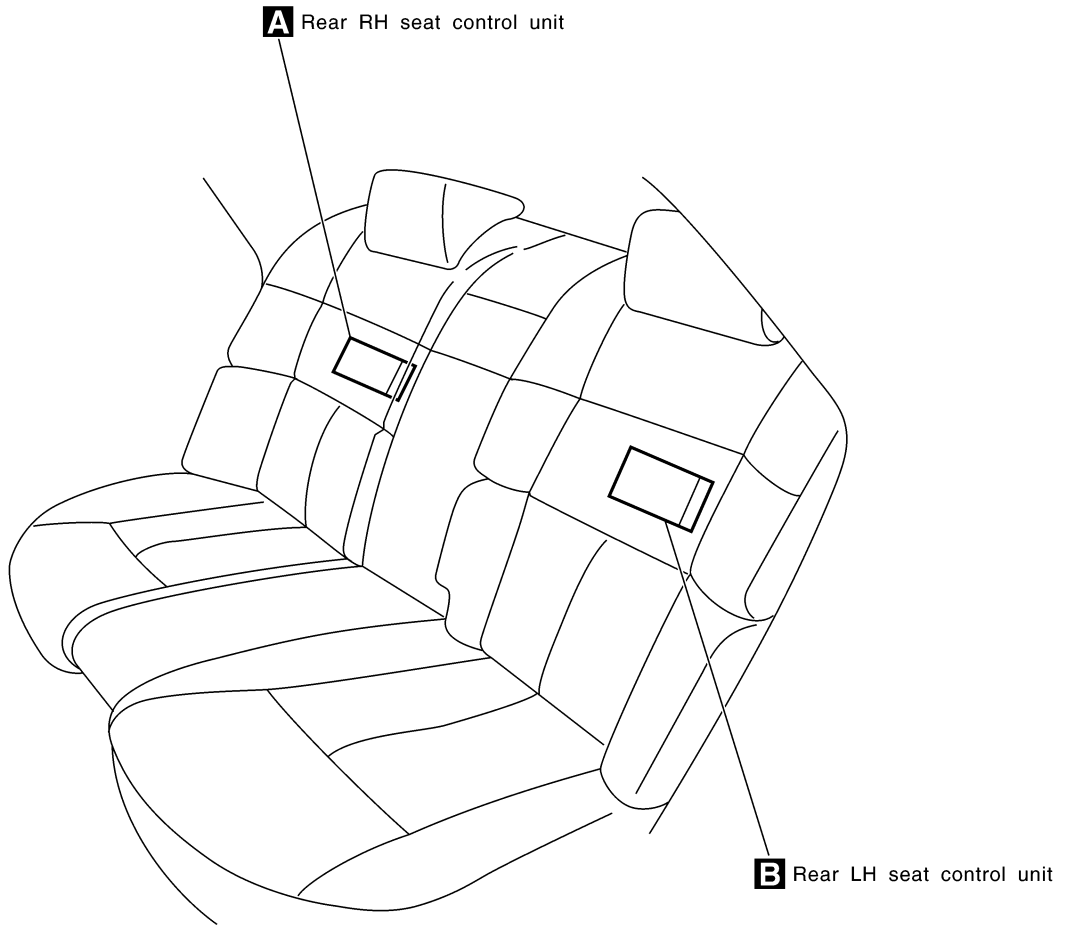

CKIT0659E

# ELECTRICAL UNITS LOCATION

## LUGGAGE COMPARTMENT

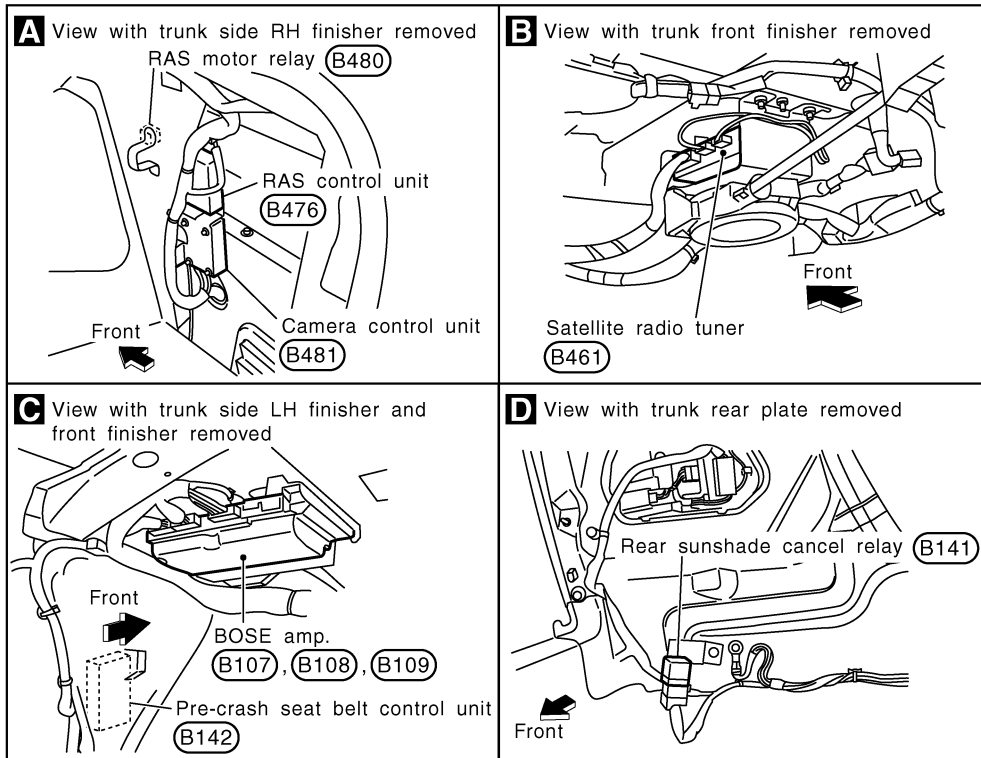
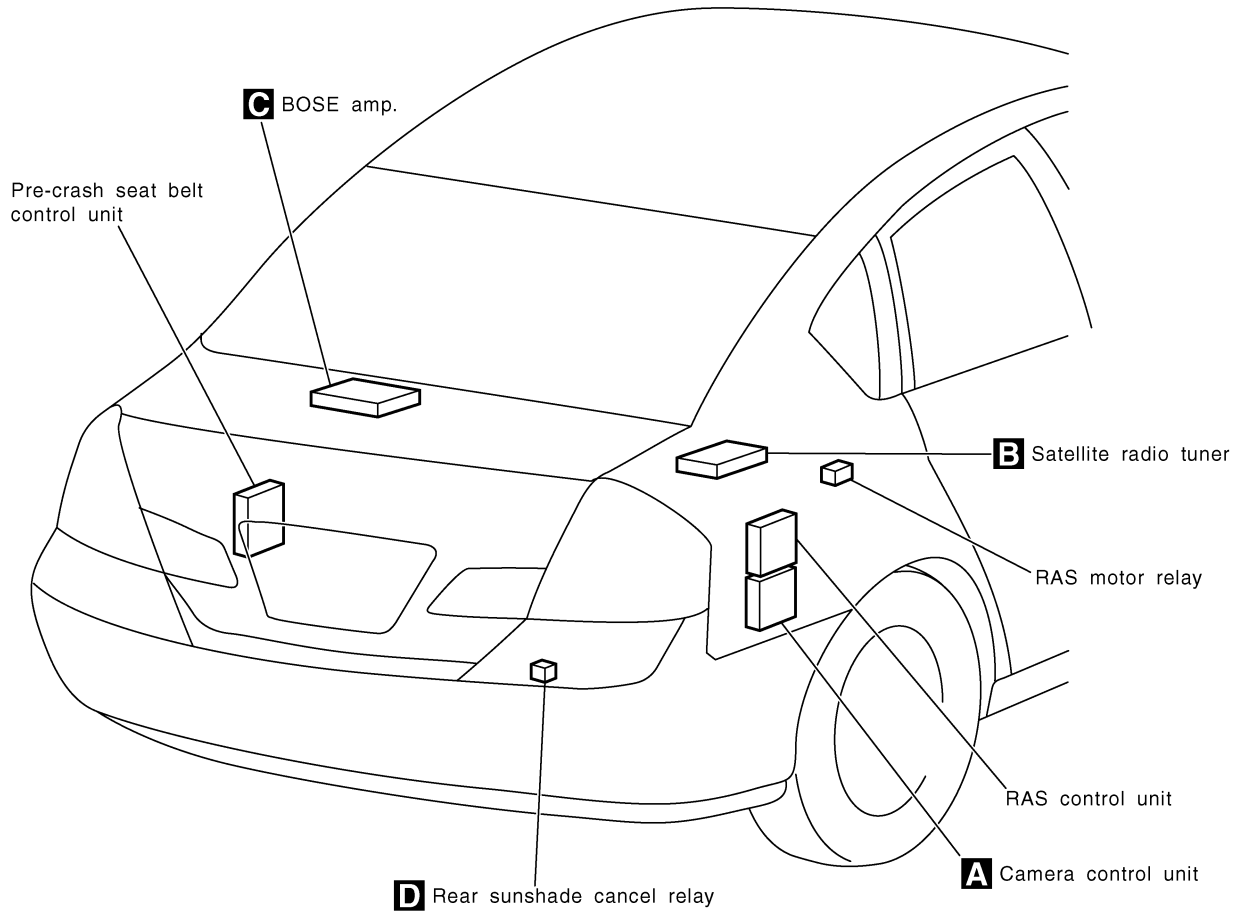

CKIT0820E

# HARNESS CONNECTOR

## HARNESS CONNECTOR

PFP:00011

### Description

#### HARNESS CONNECTOR (TAB-LOCKING TYPE)

NKS004EV

- The tab-locking type connectors help prevent accidental looseness or disconnection.
- The tab-locking type connectors are disconnected by pushing or lifting the locking tab(s). Refer to the figure below.

#### CAUTION:

Never pull the harness or wires when disconnecting the connector.

[Example]

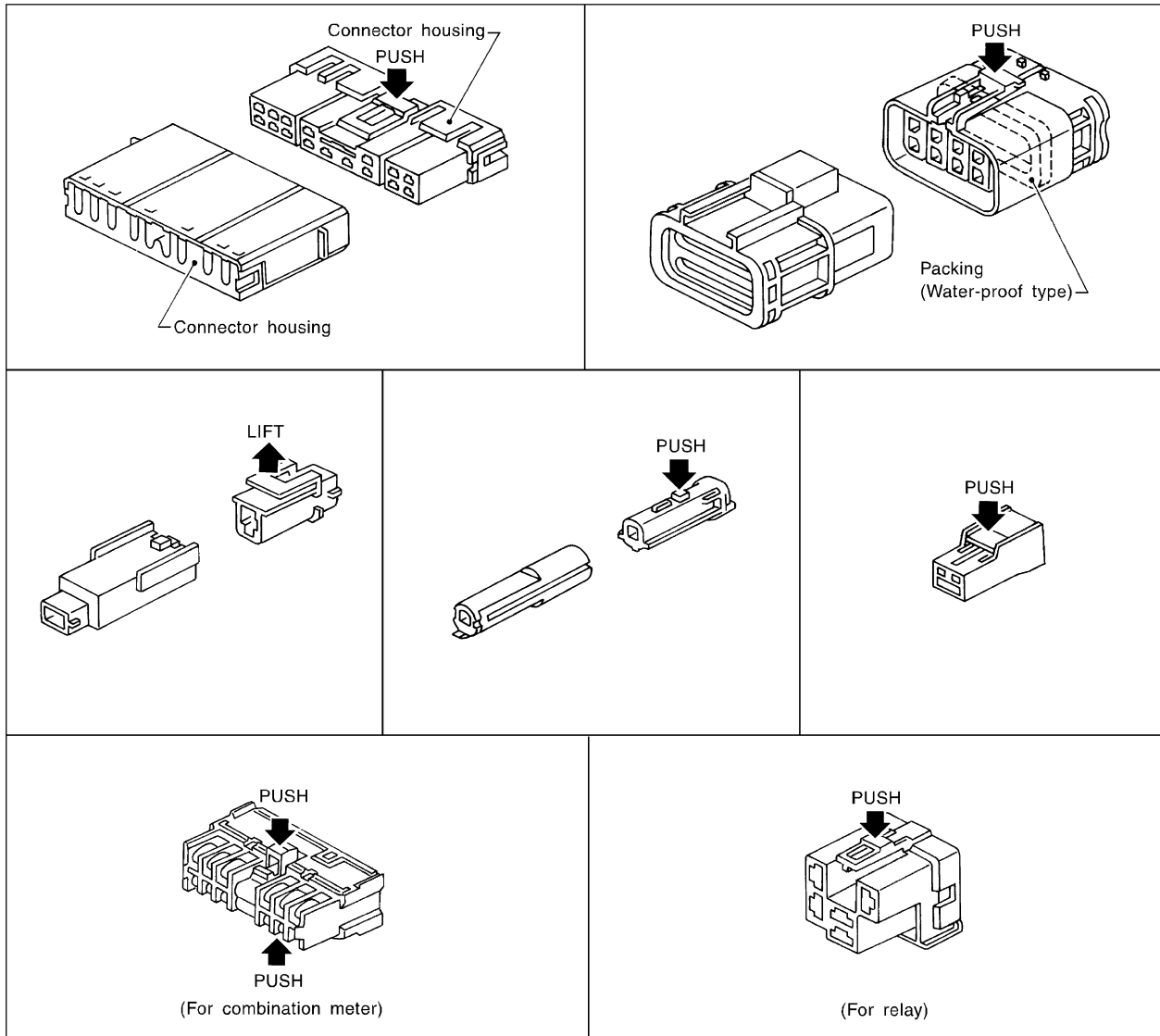

SEL769DA



# HARNESS CONNECTOR

## HARNESS CONNECTOR (SLIDE-LOCKING TYPE)

- A new style slide-locking type connector is used on certain systems and components, especially those related to OBD.
- The slide-locking type connectors help prevent incomplete locking and accidental looseness or disconnection.
- The slide-locking type connectors are disconnected by pushing or pulling the slider. Refer to the figure below.

### CAUTION:

- **Never pull the harness or wires when disconnecting the connector.**
- **Be careful not to damage the connector support bracket when disconnecting the connector.**

[Example]

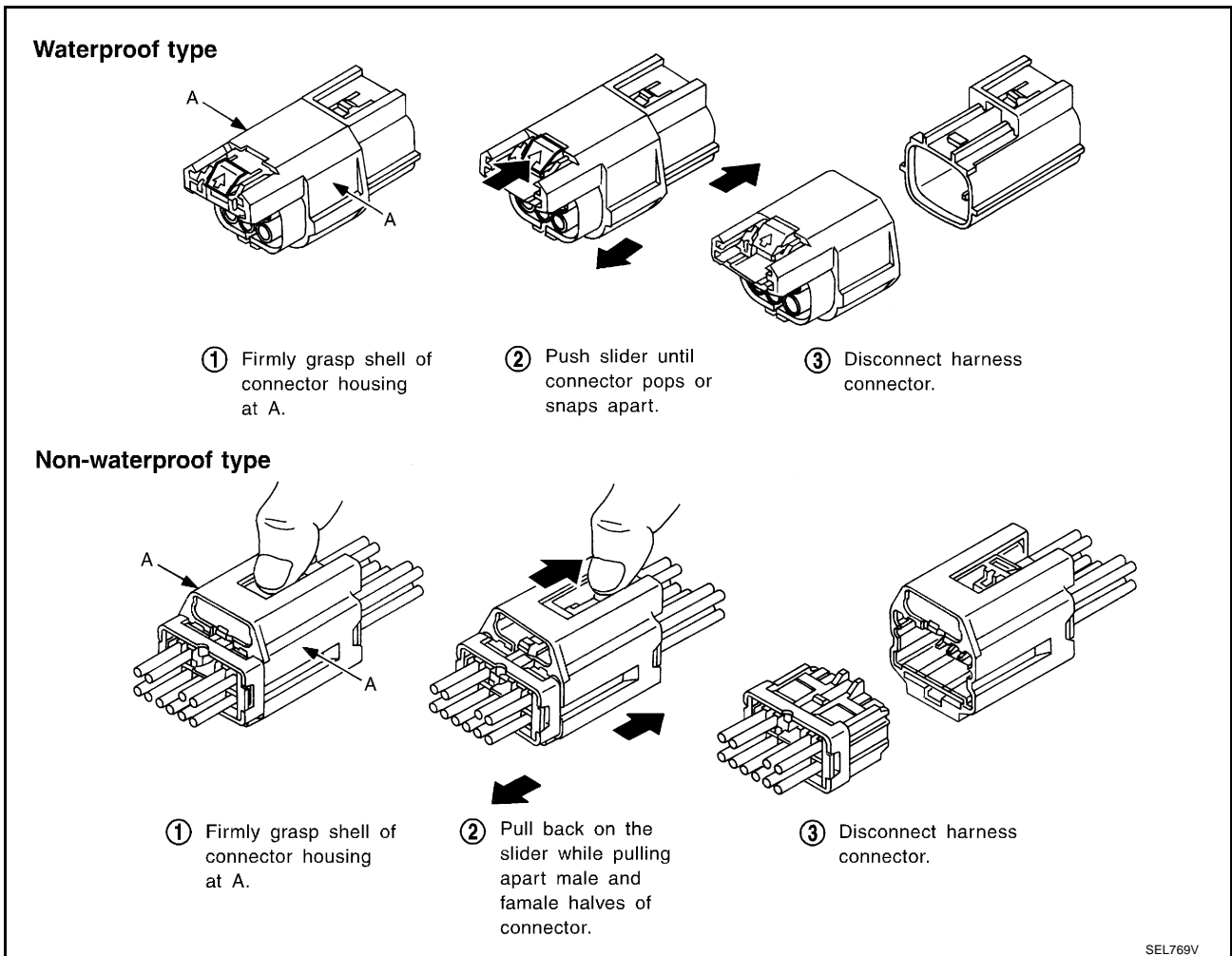

A  
B  
C  
D  
E  
F  
G  
H  
I  
J  
PG  
L  
M

# HARNESS CONNECTOR

## HARNESS CONNECTOR (LEVER LOCKING TYPE)

- Lever locking type harness connectors are used on certain control units and control modules such as ECM, ABS actuator and electric unit (control unit), etc.
- Lever locking type harness connectors are also used on super multiple junction (SMJ) connectors.
- Always confirm the lever is fully locked in place by moving the lever as far as it will go to ensure full connection.

### CAUTION:

Always confirm the lever is fully released (loosened) before attempting to disconnect or connect these connectors to avoid damage to the connector housing or terminals.

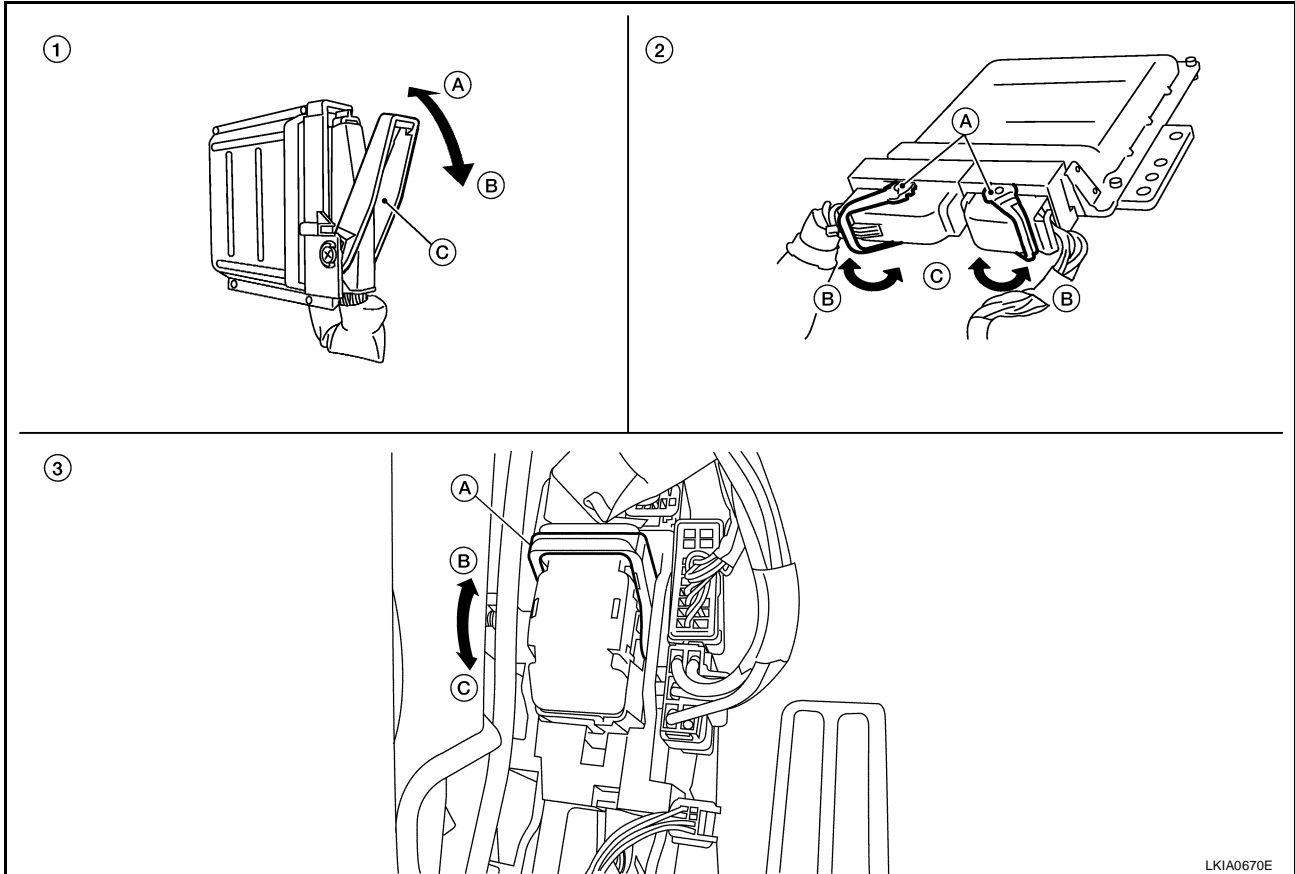

1. Control unit with single lever

- A. Fasten
- B. Loosen
- C. Lever

2. Control unit with dual levers

- A. Levers
- B. Fasten
- C. Loosen

3. SMJ connector

- A. Lever
- B. Fasten
- C. Loosen

# ELECTRICAL UNITS

## ELECTRICAL UNITS

### Terminal Arrangement

PPF:00011

NKS004EW

ECM

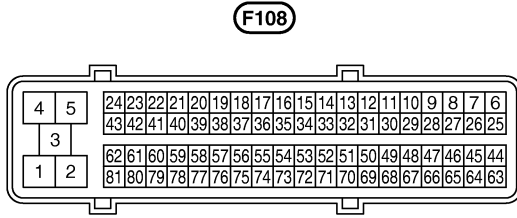

(Black)

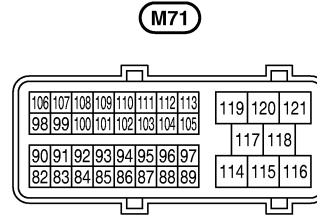

(Black)



ABS ACTUATOR AND ELECTRIC UNIT (CONTROL UNIT)

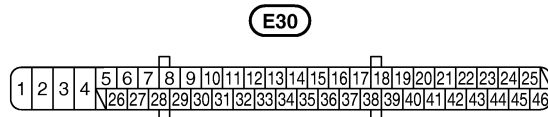

(Black)



RAS CONTROL UNIT

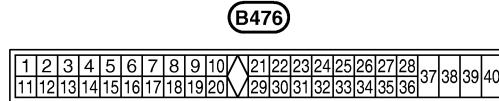

(White)



UNIFIED METER AND A/C AMP.

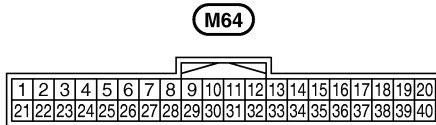

(White)

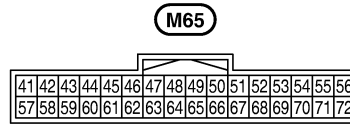

(White)



BCM (BODY CONTROL MODULE)

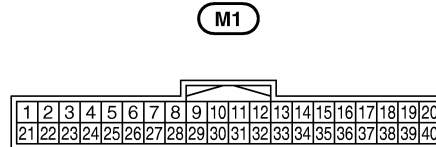

(White)

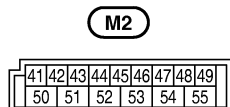

(Black)

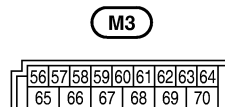

(White)



CKIT0821E

# ELECTRICAL UNITS

## INTELLIGENT KEY UNIT

**M32**

1	2	3	4	5	6	7	8	9	10	11	12	13	14	15	16	17	18	19	20
21	22	23	24	25	26	27	28	29	30	31	32	33	34	35	36	37	38	39	40

(White)

**M33**

41	42	43	44	45	46	47	48	49	50	51	52	53	54	55	56
57	58	59	60	61	62	63	64	65	66	67	68	69	70	71	72

(White)



## AV CONTROL UNIT (WITHOUT NAVIGATION SYSTEM) NAVI CONTROL UNIT (WITH NAVIGATION SYSTEM)

**M78**

40	38	36	34	32	30	28	26	24	22	20	18	16	14	12	10	8	6	4	2
39	37	35	33	31	29	27	25	23	21	19	17	15	13	11	9	7	5	3	1

(White)

**M210**

72	70	68	66	64	62	60	58	56	54	52	50	48	46	44	42
71	69	67	65	63	61	59	57	55	53	51	49	47	45	43	41

(White)



**M305**



(Gray)



# SMJ (SUPER MULTIPLE JUNCTION)

## SMJ (SUPER MULTIPLE JUNCTION)

### Terminal Arrangement

PFP:B4341

NKS004EX

MAIN HARNESS



**(M15)** (White)

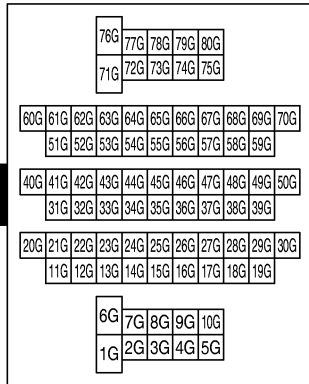

**(M12)** (White)

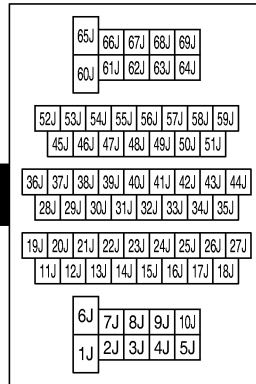

**(M13)** (White)

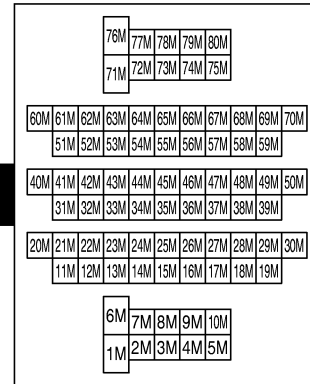

**(E108)** (White)

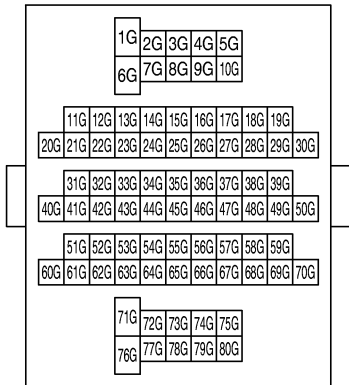

**(B1)** (White)

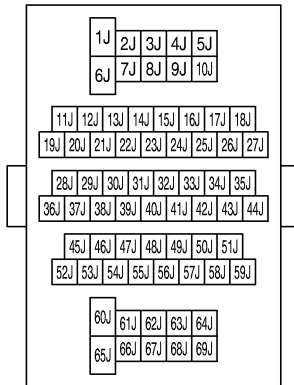

**(B2)** (White)

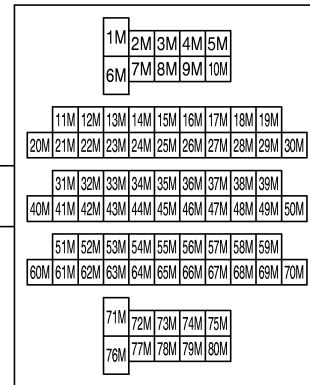

ENGINE ROOM HARNESS

BODY HARNESS

A  
B  
C  
D  
E  
F  
G  
H  
I  
J  
PG  
L  
M

CKIT0685E

# SMJ (SUPER MULTIPLE JUNCTION)

MAIN HARNESS



**M66** (White)

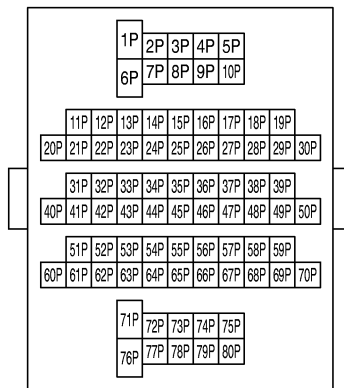
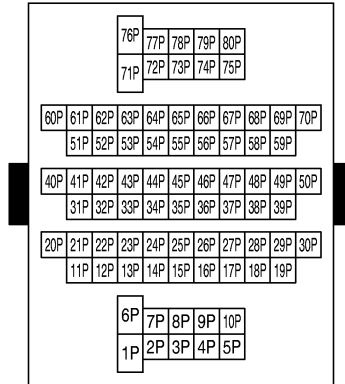

**B418** (White)

BODY No. 2 HARNESS

CKIT0822E

# SMJ (SUPER MULTIPLE JUNCTION)



## MAIN HARNESS

**M72** (White)

6H	7H	8H	9H	10H	21H	22H	23H	24H	25H	26H	27H	28H	29H	39H	40H	41H	42H	43H	44H	45H	46H		
1H	2H	3H	4H	5H	11H	12H	13H	14H	15H	16H	17H	18H	19H	20H	30H	31H	32H	33H	34H	35H	36H	37H	38H

1H	2H	3H	4H	5H	11H	12H	13H	14H	15H	16H	17H	18H	19H	20H	30H	31H	32H	33H	34H	35H	36H	37H	38H
6H	7H	8H	9H	10H	21H	22H	23H	24H	25H	26H	27H	28H	29H	39H	40H	41H	42H	43H	44H	45H	46H		

**F102** (White)

## ENGINE CONTROL HARNESS



## MAIN HARNESS

**M11** (White)

20K	21K	22K	23K	24K	25K	26K	27K	36K	37K	38K	39K		
11K	12K	13K	14K	15K	16K	17K	18K	19K	32K	33K	34K	35K	
1K	2K	3K	4K	5K	6K	7K	8K	9K	10K	28K	29K	30K	31K

**M74** (White)

20L	21L	22L	23L	24L	25L	26L	27L	36L	37L	38L	39L		
11L	12L	13L	14L	15L	16L	17L	18L	19L	32L	33L	34L	35L	
1L	2L	3L	4L	5L	6L	7L	8L	9L	10L	28L	29L	30L	31L

1K	2K	3K	4K	5K	6K	7K	8K	9K	10K	28K	29K	30K	31K
11K	12K	13K	14K	15K	16K	17K	18K	19K	32K	33K	34K	35K	
20K	21K	22K	23K	24K	25K	26K	27K	36K	37K	38K	39K		

1L	2L	3L	4L	5L	6L	7L	8L	9L	10L	28L	29L	30L	31L
11L	12L	13L	14L	15L	16L	17L	18L	19L	32L	33L	34L	35L	
20L	21L	22L	23L	24L	25L	26L	27L	36L	37L	38L	39L		

**D1** (White)

## FRONT DOOR HARNESS (DRIVER SIDE)

**D31** (White)

## FRONT DOOR HARNESS (PASSENGER SIDE)

A  
B  
C  
D  
E  
F  
G  
H  
I  
J  
L  
M

PG

CKIT0158E

# STANDARDIZED RELAY

PFP:00011

NKS004EY

## STANDARDIZED RELAY

### Description NORMAL OPEN, NORMAL CLOSED AND MIXED TYPE RELAYS

Relays can mainly be divided into three types: normal open, normal closed and mixed type relays.

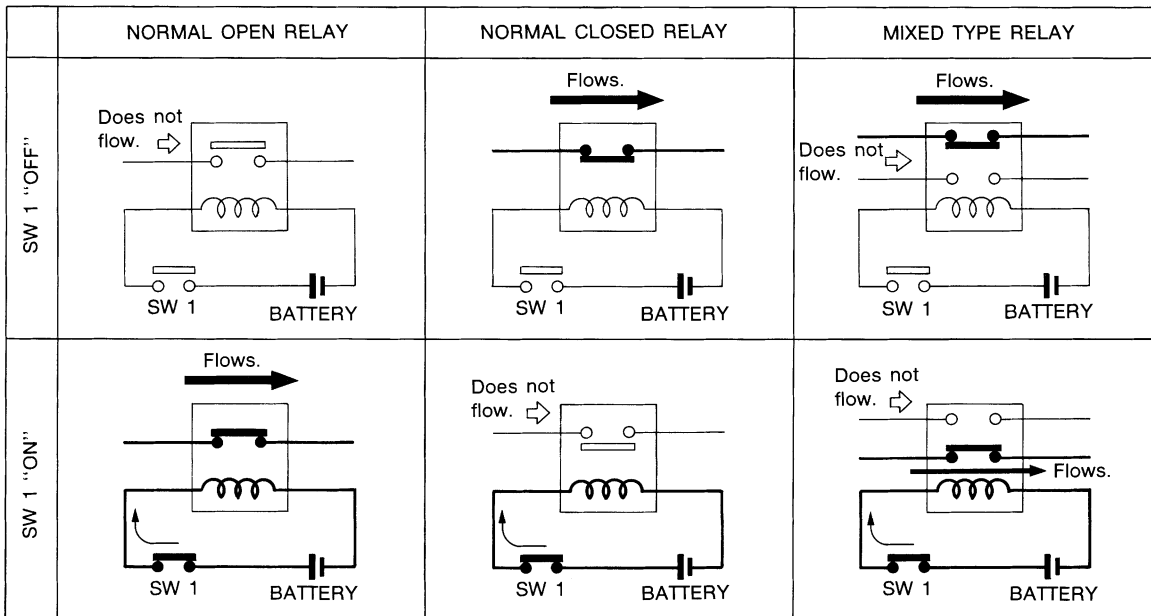

SEL881H

### TYPE OF STANDARDIZED RELAYS

- 1M ..... 1 Make
- 2M ..... 2 Make
- 1T ..... 1 Transfer
- 1M-1B ..... 1 Make 1 Break

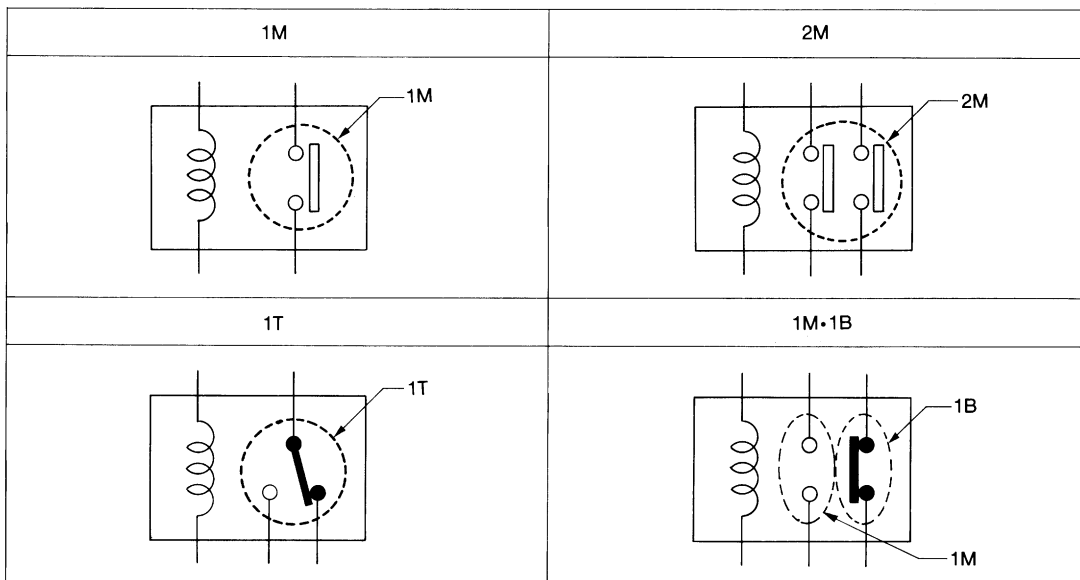

SEL882H

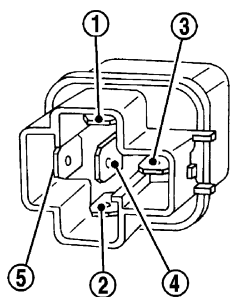
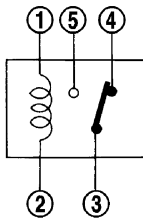
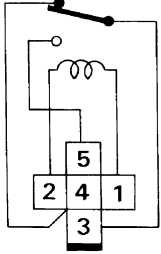
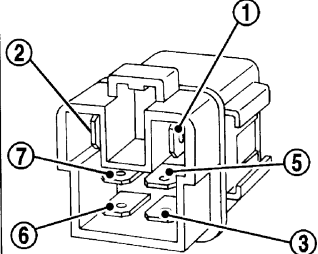
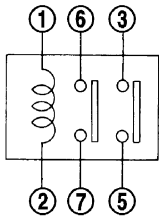
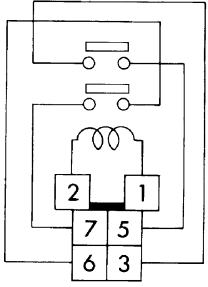
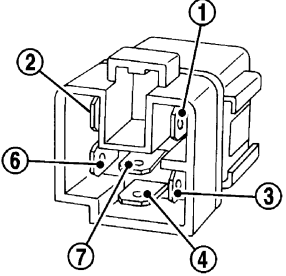
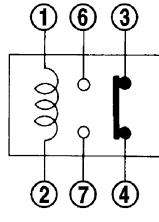
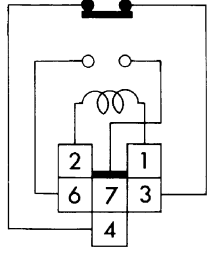
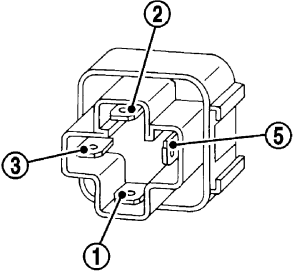
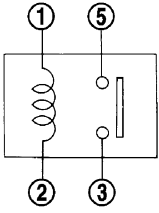
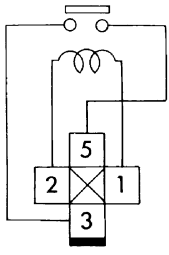
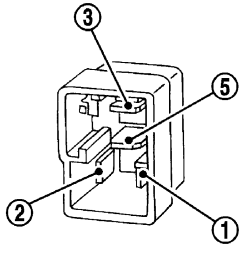
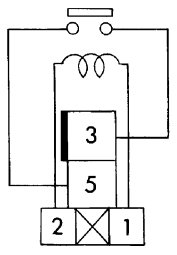

# STANDARDIZED RELAY

Type	Outer view	Circuit	Connector symbol and connection	Case color
1T				BLACK
2M				BROWN
1M•1B				GRAY
1M				BLUE
				

The arrangement of terminal numbers on the actual relays may differ from those shown above.

SEL188W

A  
B  
C  
D  
E  
F  
G  
H  
I  
J  
PG  
L  
M

# FUSE BLOCK - JUNCTION BOX (J/B)

## FUSE BLOCK - JUNCTION BOX (J/B)

PFP:24350

### Terminal Arrangement

NKS004EZ

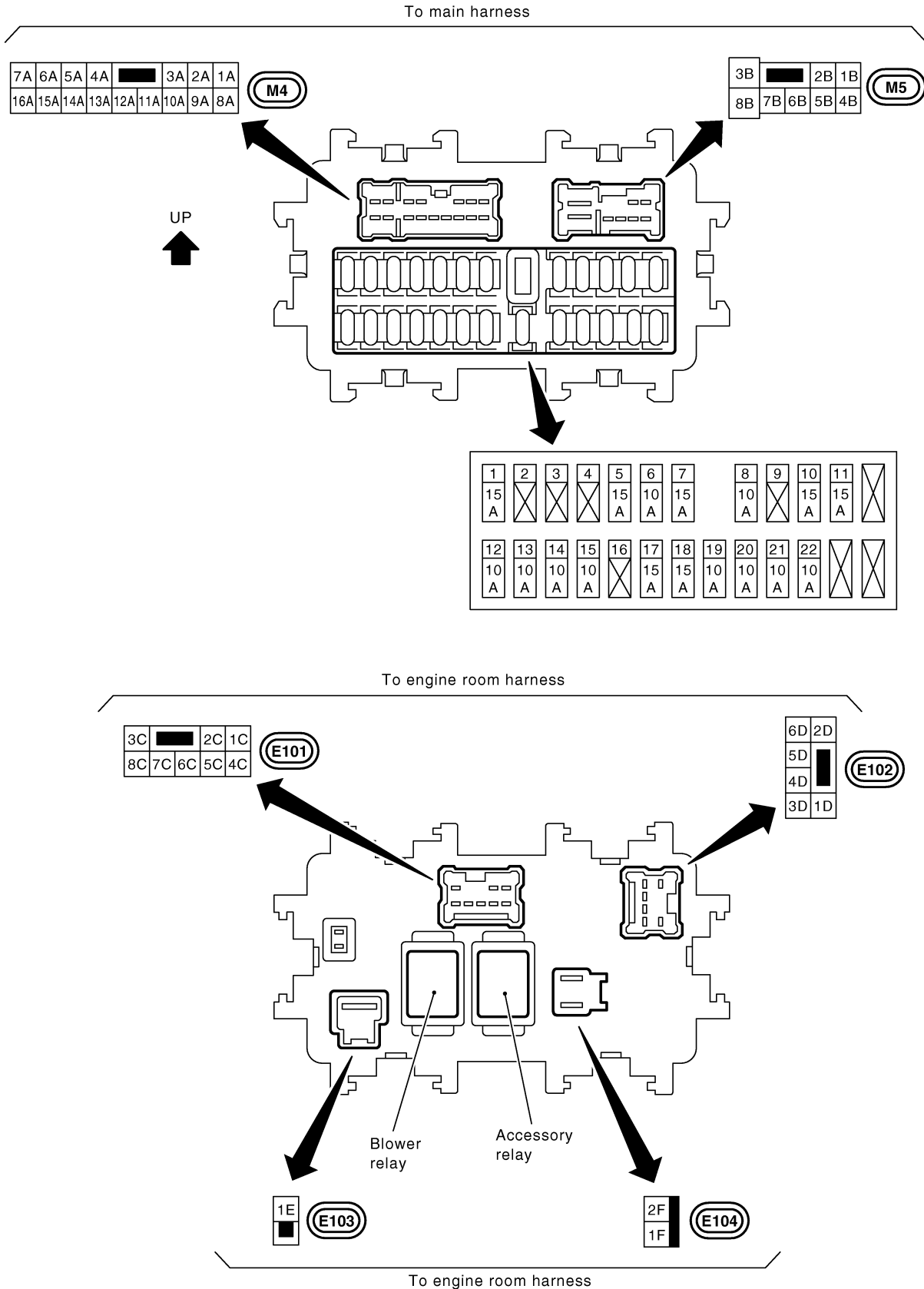

CKIT0663E

# FUSE, FUSIBLE LINK AND RELAY BOX

## FUSE, FUSIBLE LINK AND RELAY BOX

PF2:24382

### Terminal Arrangement

NKS004F0

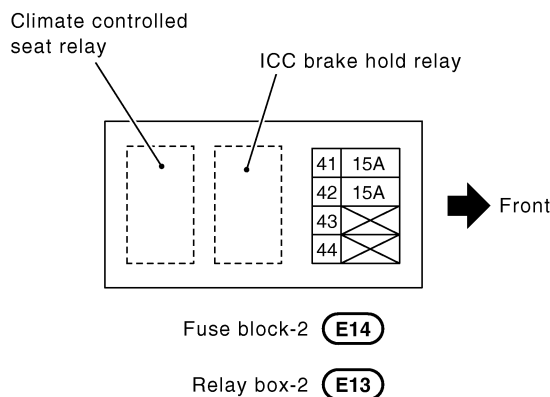
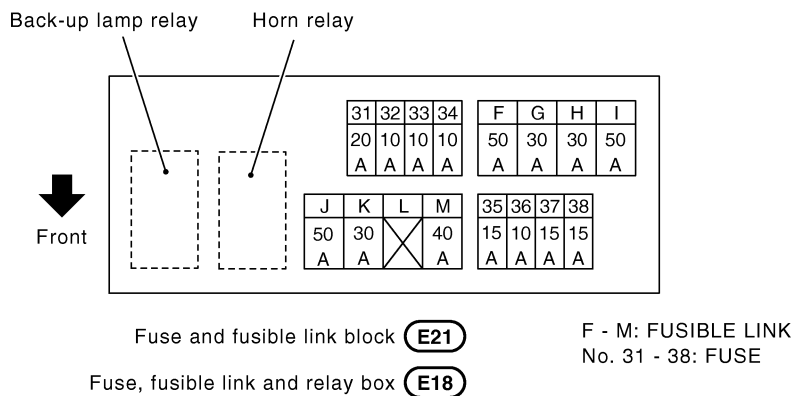
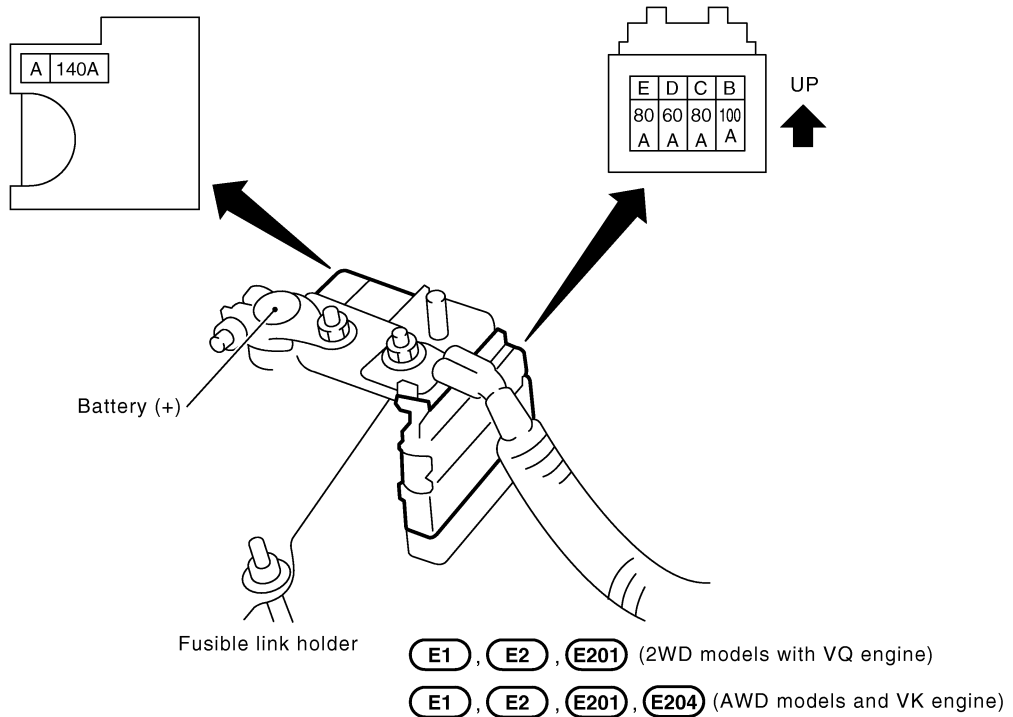

CKIT0664E

# FUSE, FUSIBLE LINK AND RELAY BOX

---