

SECTION **FAX**
FRONT AXLE

A
B
C

FAX

CONTENTS

E

SERVICE INFORMATION	2	FRONT WHEEL HUB AND KNUCKLE	6	F
PRECAUTIONS	2	On-Vehicle Inspection	6	
Caution	2	Removal and Installation	6	G
PREPARATION	3	FRONT DRIVE SHAFT	9	H
Special Service Tool	3	On-Vehicle Inspection	9	
Commercial Service Tool	4	Removal and Installation	12	
NOISE, VIBRATION AND HARSHNESS		Disassembly and Assembly	13	
(NVH) TROUBLESHOOTING	5	SERVICE DATA AND SPECIFICATIONS		I
NVH Troubleshooting Chart	5	(SDS)	19	
		Wheel Bearing	19	
		Drive Shaft	19	J

J

K

L

M

N

O

P

PRECAUTIONS

< SERVICE INFORMATION >

SERVICE INFORMATION

PRECAUTIONS

Caution

INFOID:000000002955752

Observe the following precautions when disassembling and assembling drive shaft.

- Joint sub-assembly does not disassemble because it is non-overhaul parts.
- Perform work in a location which is as dust-free as possible.
- Before disassembling and assembling, clean the outside of parts.
- Prevention of the entry of foreign objects must be taken into account during disassembly of the service location.
- Disassembled parts must be carefully reassembled in the correct order. If work is interrupted, a clean cover must be placed over parts.
- Paper shop cloths must be used. Fabric shop cloths must not be used because of the danger of lint adhering to parts.
- Disassembled parts (except for rubber parts) should be cleaned with kerosene which shall be removed by blowing with air or wiping with paper shop cloths.

PREPARATION



< SERVICE INFORMATION >

PREPARATION

Special Service Tool

INFOID:000000002955753

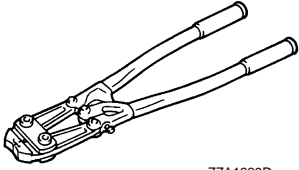
The actual shapes of Kent-Moore tools may differ from those of special service tools illustrated here.

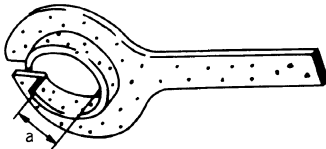
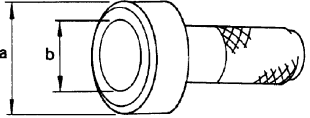
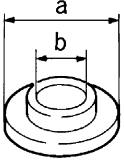
Tool number (Kent-Moore No.) Tool name	Description
KV40107300 (-) Boot band crimping tool	 ZZA1229D Installing boot band
KV40107500 (-) Drive shaft attachment	 ZZA1230D Removing drive shaft (RH side)
KV38107900 (-) Protector a: 32 mm (1.26 in) dia.	 ZZA0835D Installing drive shaft (RH side)
KV38100500 (-) Drift a: 80 mm (3.15 in) dia. b: 60 mm (2.36 in) dia.	 ZZA0701D Installing drive shaft plug
KV38102200 (-) Drift a: 90 mm (3.54 in) dia. b: 31 mm (1.22 in) dia.	 ZZA0920D Installing drive shaft plug

A
B
C
FAX
E
F
G
H
I
J
K
L
M
N
O
P

PREPARATION

< SERVICE INFORMATION >

Commercial Service Tool

INFOID:000000002955754

Tool name	Description
Power tool	Loosening bolts and nuts

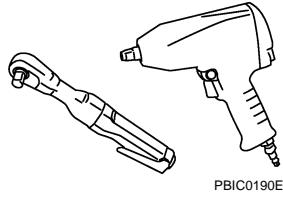

NOISE, VIBRATION AND HARSHNESS (NVH) TROUBLESHOOTING

< SERVICE INFORMATION >

NOISE, VIBRATION AND HARSHNESS (NVH) TROUBLESHOOTING

NVH Troubleshooting Chart

INFOID:00000002955755

Use chart below to help you find the cause of the symptom. If necessary, repair or replace these parts.

Reference page			—	FAX-13	—	FAX-6	—	FAX-6	NVH in FAX and FSU sections	Refer to Front axle in this chart.	NVH in WT section	NVH in WT section	Refer to DRIVE SHAFT in this chart.	NVH in BR section	NVH in PS section	
Possible cause and SUSPECTED PARTS			Excessive joint angle	Joint sliding resistance	Imbalance	Improper installation, looseness	Parts interference	Wheel bearing damage	FRONT AXLE AND FRONT SUSPENSION	FRONT AXLE	TIRES	ROAD WHEEL	DRIVE SHAFT	BRAKES	STEERING	
Symptom	DRIVE SHAFT	Noise	x	x				x	x	x	x	x		x	x	
		Shake	x		x				x	x	x	x		x	x	
	FRONT AXLE	Noise				x	x	x	x		x	x	x	x	x	x
		Shake				x	x	x	x		x	x	x	x	x	x
		Vibration				x	x	x	x		x		x			x
		Shimmy				x	x		x		x	x		x	x	x
		Judder				x			x		x	x		x	x	x
Poor quality ride or handling				x	x		x		x	x						

x: Applicable

A
B
C
D
E
F
G
H
I
J
K
L
M
N
O
P

FAX

FRONT WHEEL HUB AND KNUCKLE

< SERVICE INFORMATION >

FRONT WHEEL HUB AND KNUCKLE

On-Vehicle Inspection

INFOID:000000002955756

Make sure that the mounting conditions (looseness, backlash) of each component and component conditions (wear, damage) are normal.

WHEEL BEARING INSPECTION

- Move wheel hub and bearing assembly in the axial direction by hand. Make sure there is no looseness of wheel bearing.

Axial end play : 0.05 mm (0.002 in) or less

- Rotate wheel hub and make sure that is no unusual noise or other irregular conditions. If there is any of irregular conditions, replace wheel hub and bearing assembly

Removal and Installation

INFOID:000000002955757

COMPONENT

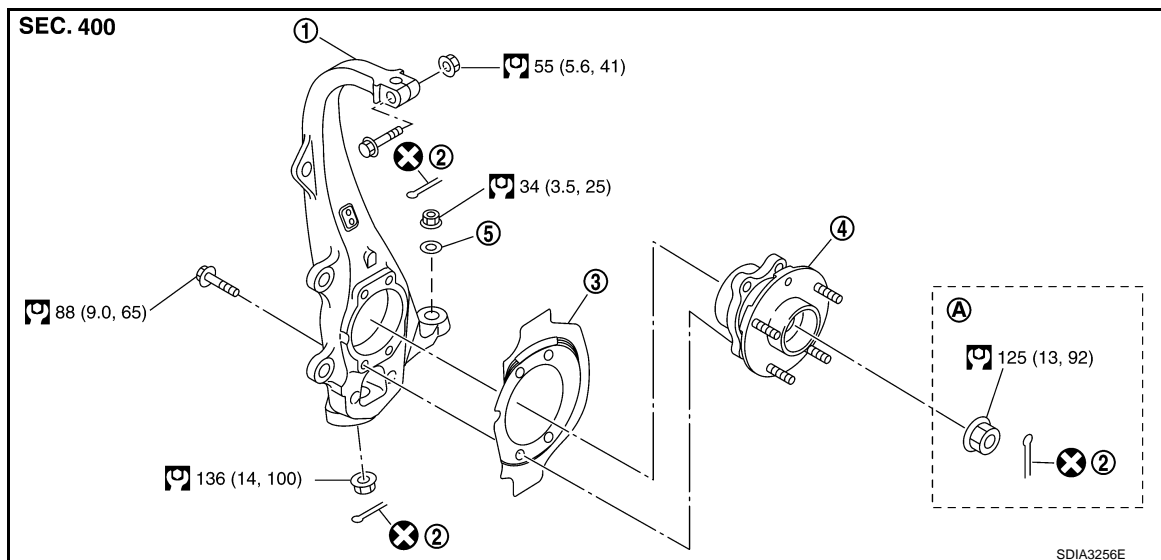

- | | | |
|-----------------------------------|---------------|-----------------|
| 1. Steering knuckle | 2. Cotter pin | 3. Splash guard |
| 4. Wheel hub and bearing assembly | 5. Washer | |

A: AWD models

Refer to [GI-9, "Component"](#), for the symbols in the figure.

REMOVAL

Wheel Hub and Bearing Assembly

1. Remove tires from vehicle with power tool.
2. Remove wheel sensor from steering knuckle. Refer to [BRC-58](#).
CAUTION:
Do not pull on wheel sensor harness.
3. Remove brake hose bracket. Refer to [BR-11](#).
4. Remove torque member fixing bolts with power tool. Hang torque member in a place where it will not interfere with work. Refer to [BR-21, "Component"](#).
CAUTION:
Do not depress brake pedal while brake caliper is removed.

FRONT WHEEL HUB AND KNUCKLE

< SERVICE INFORMATION >

- Put matching mark (A) on disc rotor and wheel hub and bearing assembly, then remove disc rotor.
- Remove cotter pin, then loosen hub lock nut with power tool. (AWD)

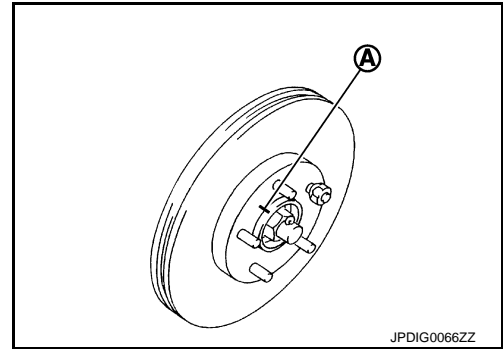

- Separate wheel hub and bearing assembly from drive shaft by lightly tapping the end with a hammer (suitable tool) and a wood block, and then remove hub lock nut. (AWD)

CAUTION:

- Do not place drive shaft joint at an extreme angle. Also be careful not to overextend slide joint.
- Do not allow drive shaft to hang down without support for housing (or joint sub-assembly), shaft and the other parts.

NOTE:

Use a puller (suitable tool) if wheel hub and bearing assembly and drive shaft cannot be separated even after performing the above procedure.

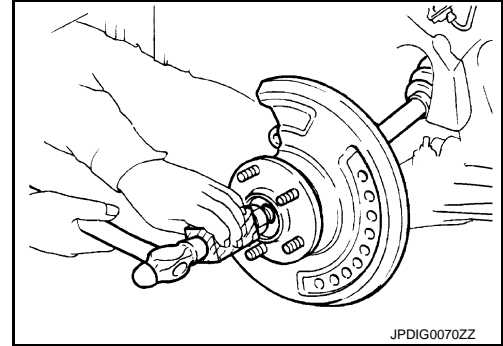

- Remove wheel hub and bearing assembly mounting bolts, and then remove splash guard and wheel hub and bearing assembly from steering knuckle.

Steering knuckle

- Refer to the procedure from 1 to 7 in "Wheel Hub and Bearing Assembly" "REMOVAL".
- Remove cotter pin (1), and then loosen the nut.
- Remove steering outer socket (2) from steering knuckle (3) so as not to damage ball joint boot (4) using the ball joint remover (suitable tool).

CAUTION:

Temporarily tighten the nut to prevent damage to threads and to prevent the ball joint remover (suitable tool) from suddenly coming off.

- Remove cotter pin of transverse link and steering knuckle, and then loosen nut.
- Remove transverse link from steering knuckle so as not to damage ball joint boot using the ball joint remover (suitable tool).

CAUTION:

Temporarily tighten the nut to prevent damage to threads and to prevent ball joint remover (suitable tool) from suddenly coming off.

- Remove fixing nut and bolt with power tool, and then remove steering knuckle from upper link. Refer to [FSU-7, "Component"](#).
- Remove wheel hub and bearing assembly mounting bolts, and then remove splash guard and wheel hub and bearing assembly from steering knuckle.

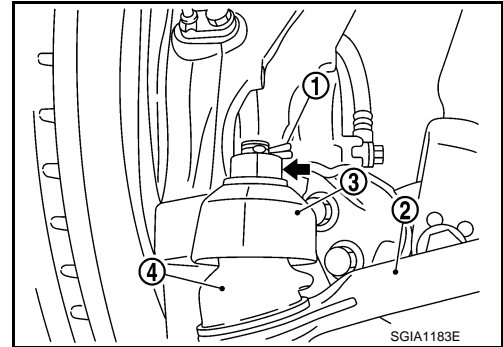

INSPECTION AFTER REMOVAL

Check components for deformation, cracks, and other damage. Replace if there are.

Ball Joint Inspection

Check boots of transverse link and steering outer socket ball joint for breakage, axial play, and torque. Refer to [FSU-13, "Removal and Installation"](#), "TRANSVERSE LINK", [PS-18, "Removal and Installation"](#), "POWER STEERING GEAR".

INSTALLATION

- Installation is the reverse order of the removal. For tightening torque, refer to "COMPONENT".

A
B
C
FAX
E
F
G
H
I
J
K
L
M
N
O
P

FRONT WHEEL HUB AND KNUCKLE

< SERVICE INFORMATION >

- Perform the final tightening of each of parts under unladen conditions, which were removed when removing wheel hub and bearing assembly and steering knuckle. Check the wheel alignment. Refer to [FSU-5, "Wheel Alignment Inspection"](#) (2WD), [FSU-22, "Wheel Alignment Inspection"](#) (AWD).
- Adjust neutral position of steering angle sensor after checking the wheel alignment. Refer to [BRC-8, "Adjustment of Steering Angle Sensor Neutral Position"](#).
- Check wheel sensor harness for proper connection. Refer to [BRC-58](#).
- Assemble disc rotor and wheel hub and bearing assembly by aligning each matching mark (A) as shown in the figure when installing disc rotor.

NOTE:

Refer to [BR-22, "Removal and Installation of Brake Caliper Assembly"](#), for assembly when removing disc rotor without matching mark.

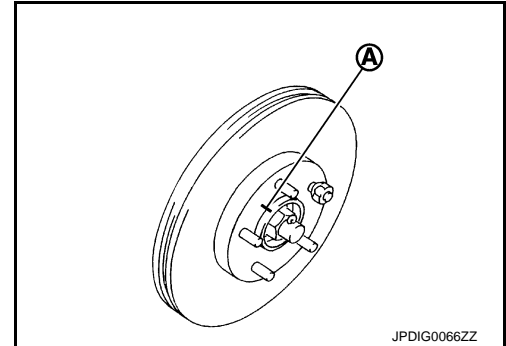

FRONT DRIVE SHAFT

< SERVICE INFORMATION >

FRONT DRIVE SHAFT

On-Vehicle Inspection

INFOID:00000002955758

- Check drive shaft mounting point and joint for looseness and other damage.
- Check boot for cracks and other damage.

CAUTION:

Replace entire drive shaft assembly when noise or vibration occur from drive shaft.

DRIVE SHAFT BOOT REPLACEMENT

1. Remove tires from vehicle with power tool.
2. Remove wheel sensor from steering knuckle. Refer to [BRC-58](#).
3. Remove brake hose bracket. Refer to [BR-11](#).
4. Remove torque member fixing bolts with power tool. Hang torque member in a place where it will not interfere with work. Refer to [BR-21. "Component"](#).

NOTE:

Do not depress brake pedal while brake caliper is removed.

5. Remove disc rotor. Refer to [BR-22. "Removal and Installation of Brake Caliper Assembly"](#).
6. Remove cotter pin, then loosen hub lock nut with power tool.

7. Separate wheel hub and bearing assembly from drive shaft by lightly tapping the end with a hammer (suitable tool) and a wood block, and then remove hub lock nut.

CAUTION:

- Do not place drive shaft joint at an extreme angle. Also be careful not to overextend slide joint.
- Do not allow drive shaft to hang down without support for housing (or joint sub-assembly), shaft and the other parts.

NOTE:

Use a puller (suitable tool) if wheel hub and drive shaft cannot be separated even after performing the above procedure.

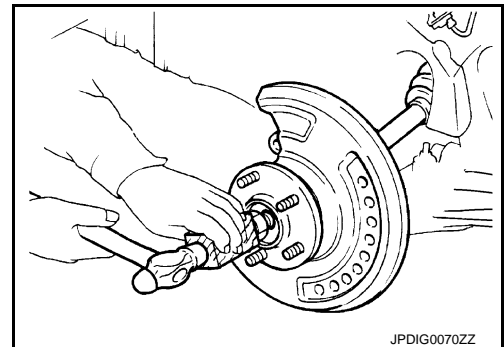

8. Remove cotter pin (1), and then loosen the nut.
9. Remove steering outer socket (2) from steering knuckle (3) so as not to damage ball joint boot (4) using the ball joint remover (suitable tool).

CAUTION:

Temporarily tighten the nut to prevent damage to threads and to prevent the ball joint remover (suitable tool) from suddenly coming off.

10. Remove cotter pin of transverse link and steering knuckle, and then loosen nut.

11. Remove transverse link from steering knuckle so as not to damage ball joint boot using the ball joint remover (suitable tool).

CAUTION:

Temporarily tighten the nut to prevent damage to threads and to prevent ball joint remover (suitable tool) from suddenly coming off.

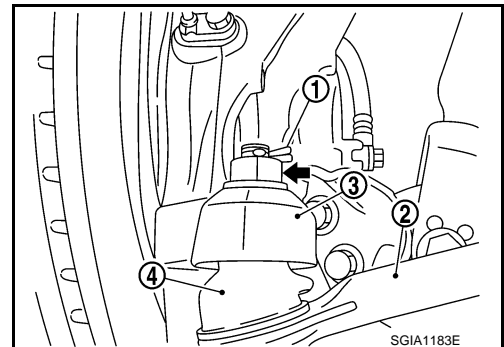

12. Remove drive shaft from wheel hub and bearing assembly.
13. Remove boot bands, and then remove boot from joint sub-assembly.

A
B
C
E
F
G
H
I
J
K
L
M
N
O
P

FAX

FRONT DRIVE SHAFT

< SERVICE INFORMATION >

14. Screw a drive shaft puller (suitable tool) into joint sub-assembly screw part to a length of 30 mm (1.18 in) or more. Support drive shaft with one hand and pull out joint sub-assembly with a sliding hammer (suitable tool) from shaft.

CAUTION:

- Align a sliding hammer and drive shaft and remove them by pulling firmly and uniformly.
- If joint sub-assembly cannot be pulled out, try after removing drive shaft from vehicle.

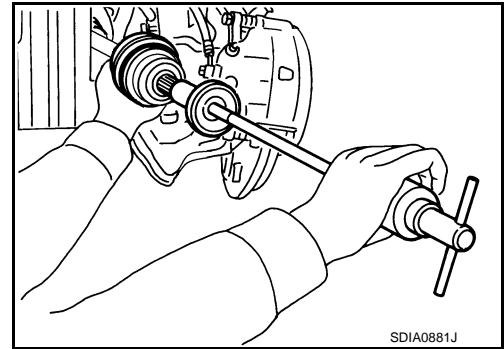

15. Remove the circular clip (1) from shaft.
16. Remove boot from shaft.
17. Clean the old grease on joint sub-assembly with paper towels.

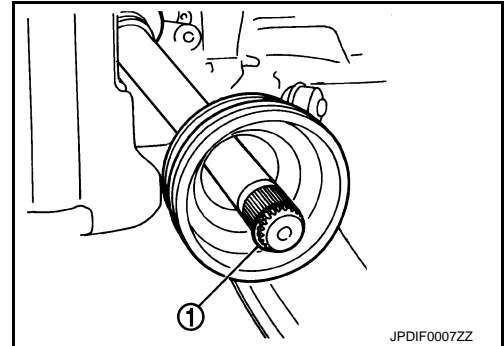

18. Fill serration slot joint sub-assembly (1) with NISSAN genuine grease or equivalent until the serration slot and ball groove become full to the brim.

CAUTION:

After applying grease, use a shop cloth to wipe off old grease that has oozed out.

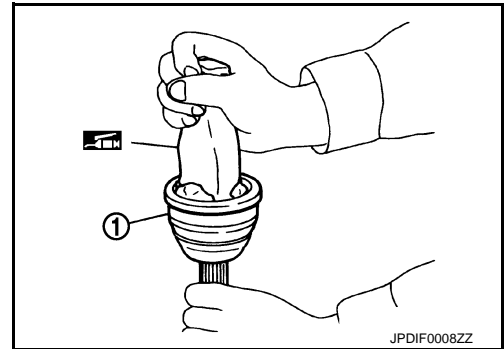

19. Wrap serration on shaft with tape (A) to protect the boot from damage. Install new boot and boot bands to shaft.

CAUTION:

Never reuse boot and boot band.

20. Remove the tape wrapped around the serration on shaft.

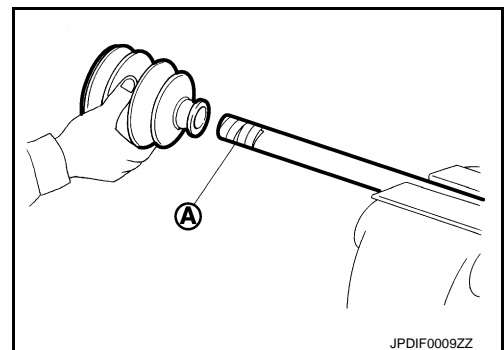

21. Position circular clip (1) on groove at the shaft edge. Align both counter axles of the shaft edge and joint sub-assembly. Then, assemble shaft with circular clip onto joint sub-assembly.

CAUTION:

Never reuse circular clip.

NOTE:

Drive joint inserter (suitable tool) is recommended when installing circular clip.

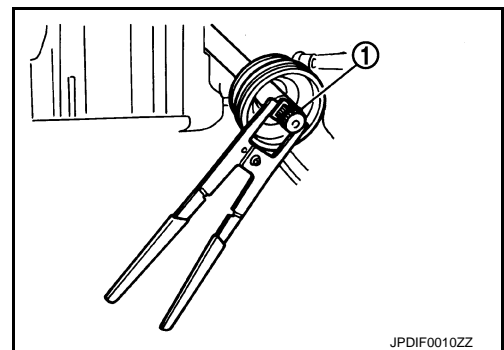

FRONT DRIVE SHAFT

< SERVICE INFORMATION >

22. Install joint sub-assembly (1) to shaft using plastic hammer.

CAUTION:

Confirm that joint sub-assembly is correctly engaged while rotating drive shaft.

23. Apply the balance of the specified amount of grease (NISSAN genuine grease or equivalent) into the boot inside from large diameter side of boot.

Grease amount : Refer to [FAX-19, "Drive Shaft"](#).

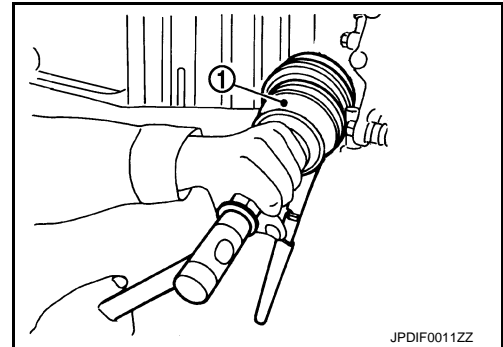

24. Install the boot securely into grooves (indicated by *marks) shown in the figure.

CAUTION:

If grease adheres to the boot mounting surface (with *mark) on the shaft and joint sub-assembly, boot may come off. Remove all grease from the surface.

25. To prevent from the deformation of the boot, adjust the boot installation length to the specified value shown below (L) by inserting the flat-bladed screwdriver into inside of the boot from the large diameter side of the boot and discharging the inside air.

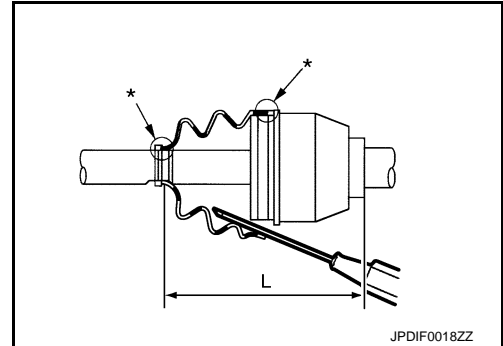

Boot installation length (L) : Refer to [FAX-19, "Drive Shaft"](#).

CAUTION:

- If the boot mounting length is outside the standard, it may cause breakage in the boot.
- Be careful not to touch the inside of the boot with a tip of a flat-bladed screwdriver.

26. Secure the large and small ends of the boot with new boot bands using the boot band crimping tool [SST: KV40107300 (-)] as shown in the figure.

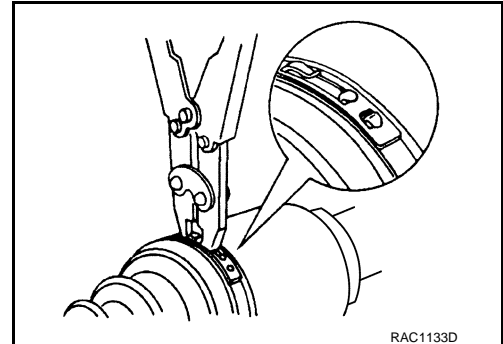

NOTE:

Secure boot band so that dimension "M" meets the specification as shown.

Dimension "M" : 2.0 – 3.0 mm (0.079 – 0.118 in)

27. Secure joint sub-assembly and shaft, and then make sure that they are in the correct position when rotating boot. Install them with new boot band when boot installation positions become incorrect.

28. Insert drive shaft to wheel hub and bearing assembly, and then temporarily tighten hub lock nut.

29. Install transverse link to steering knuckle. Refer to [FSU-13, "Removal and Installation"](#) (2WD), [FSU-30, "Removal and Installation"](#) (AWD).

30. Install steering outer socket to steering knuckle. Refer to [PS-18, "Removal and Installation"](#).

31. Install disc rotor. Refer to [BR-22, "Removal and Installation of Brake Caliper Assembly"](#).

32. Install torque member fixing bolts to steering knuckle. Refer to [BR-21, "Component"](#).

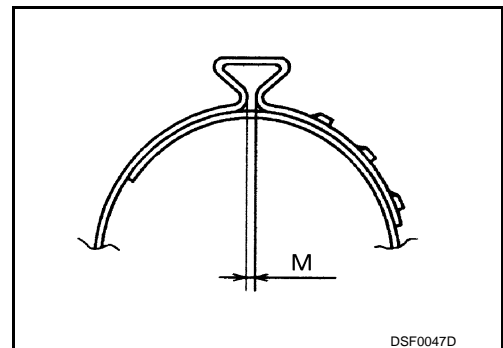

FRONT DRIVE SHAFT

< SERVICE INFORMATION >

33. Install brake hose bracket to steering knuckle. Refer to [BR-11](#).
34. Install wheel sensor to steering knuckle. Refer to [BRC-58](#).
35. Tighten the hub lock nut to the specified torque. Refer to [FAX-6, "Removal and Installation"](#).
36. Install cotter pin.
37. Install tires to vehicle.

Removal and Installation

INFOID:000000002955759

COMPONENT

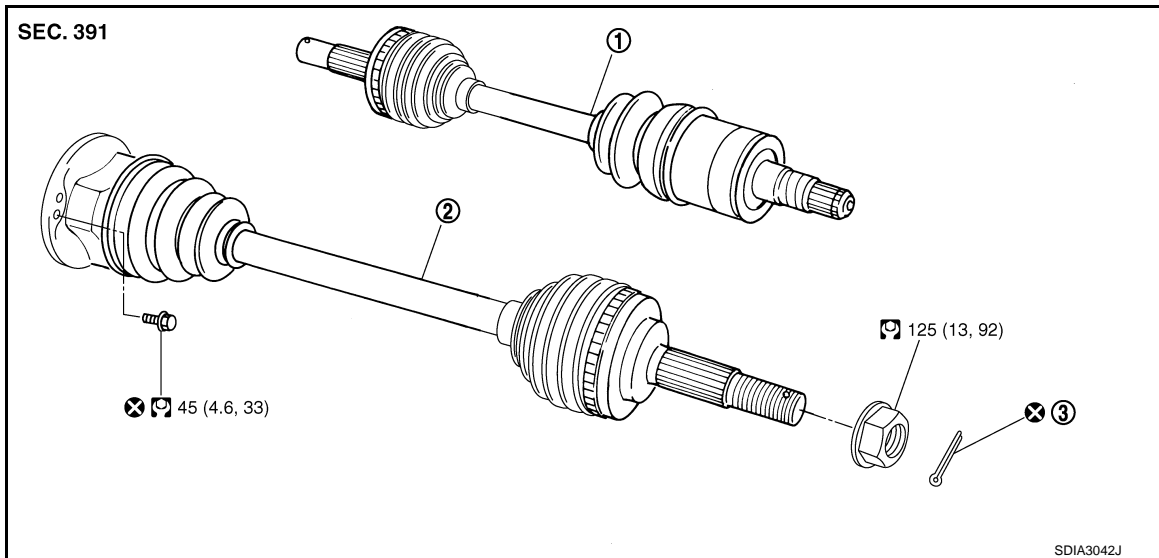

1. Drive shaft (RH side)
2. Drive shaft (LH side)
3. Cotter pin

Refer to [GI-9, "Component"](#), for the symbols on the figure.

REMOVAL

1. Remove tires from vehicle with power tool.
2. Remove wheel sensor from steering knuckle. Refer to [BRC-58](#).
3. Remove brake hose bracket. Refer to [BR-11](#).
4. Remove torque member fixing bolts with power tool. Hang torque member in a place where it will not interfere with work. Refer to [BR-21, "Component"](#).
5. Remove disc rotor. Refer to [BR-22, "Removal and Installation of Brake Caliper Assembly"](#).
6. Remove cotter pin, then loosen hub lock nut with power tool.
7. Separate wheel hub and bearing assembly from drive shaft by lightly tapping the end with a hammer (suitable tool) and a wood block, and then remove hub lock nut.

CAUTION:

- Do not place drive shaft joint at an extreme angle. Also be careful not to overextend slide joint.
- Do not allow drive shaft to hang down without support for housing (or joint sub-assembly), shaft and the other parts.

NOTE:
Use a puller (suitable tool) if wheel hub and drive shaft cannot be separated even after performing the above procedure.

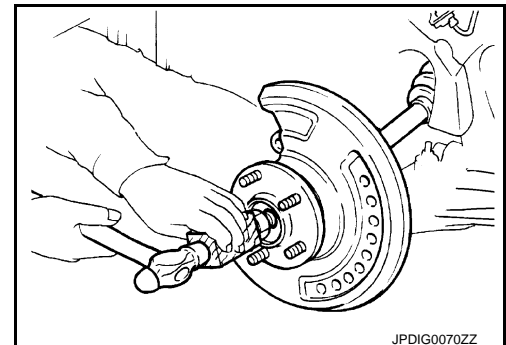

FRONT DRIVE SHAFT

< SERVICE INFORMATION >

8. Remove cotter pin (1), and then loosen the nut.
9. Remove steering outer socket (2) from steering knuckle (3) so as not to damage ball joint boot (4) using the ball joint remover (suitable tool).

CAUTION:

Temporarily tighten the nut to prevent damage to threads and to prevent the ball joint remover (suitable tool) from suddenly coming off.

10. Remove drive shaft from wheel hub and bearing assembly.
11. Remove fixing nuts and bolts, and then remove shock absorber arm. Refer to [FSU-24, "Component"](#).

12. Remove drive shaft from front final drive. (RH side)
 - Remove drive shaft from front final drive using the drive shaft attachment (A) [SST: KV40107500 (—)] and a sliding hammer (B) while inserting tip of the drive shaft attachment between housing and front final drive.

CAUTION:

Never place drive shaft joint at an extreme angle when removing drive shaft. Also be careful not to overextend slide joint.

13. Remove fixing nuts and bolts, and then remove drive shaft from vehicle. (LH side)

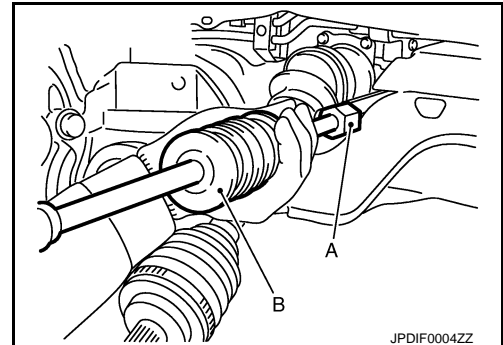
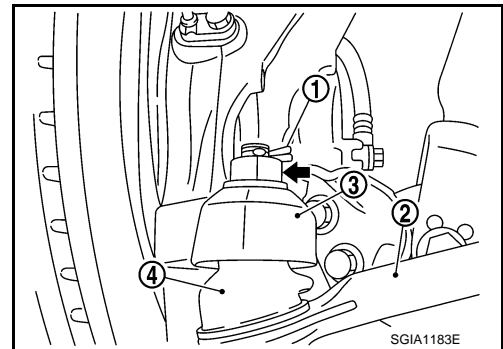

INSPECTION AFTER REMOVAL

- Move joint up/down, left/right, and in the axial directions. Check for motion that is not smooth and for significant looseness.
- Check boot for cracks, damage, and leakage of grease.
- Disassemble drive shaft and exchange malfunctioning part if there is a non-standard condition.

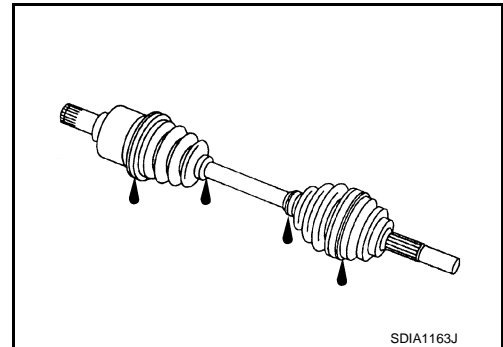

INSTALLATION

CAUTION:

Always replace transaxle side oil seal with new one when installing drive shaft. Refer to [FFD-12](#).

- Installation is the reverse order of removal. For tightening torque refer to "COMPONENT".
- Place the protector (A) [SST: KV38107900 (—)] onto front final drive to prevent damage to the oil seal while inserting drive shaft. Slide drive shaft sliding joint and tap with a hammer to install securely. (RH side)

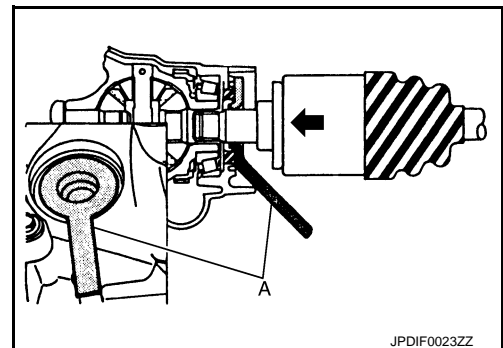

Disassembly and Assembly

COMPONENT

INFOID:000000002955760

FRONT DRIVE SHAFT

< SERVICE INFORMATION >

VQ35DE models

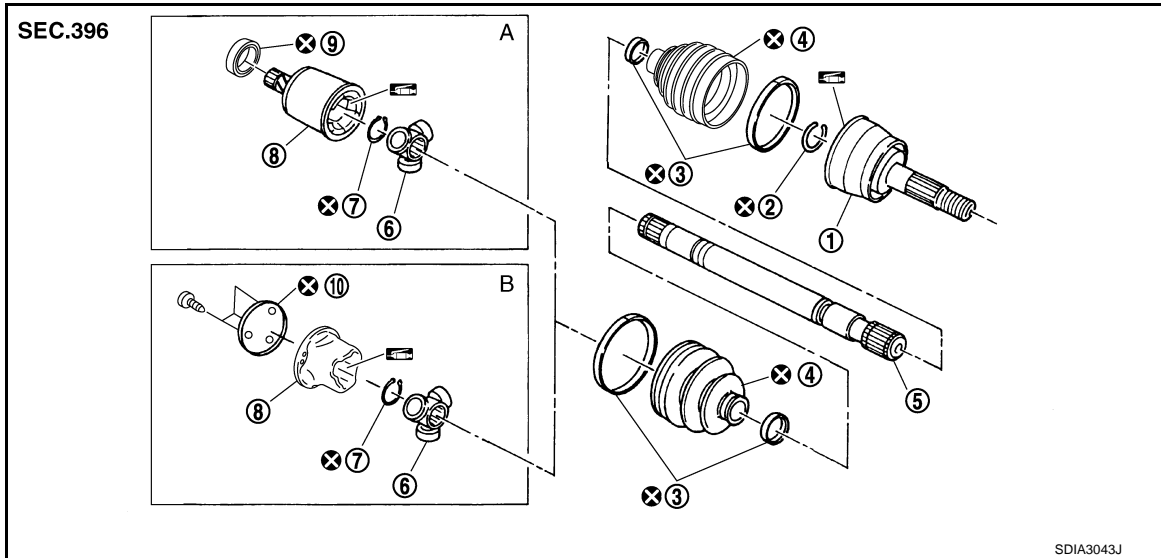

- | | | |
|-----------------------|------------------|--------------------|
| 1. Joint sub-assembly | 2. Circular clip | 3. Boot band |
| 4. Boot | 5. Shaft | 6. Spider assembly |
| 7. Snap ring | 8. Housing | 9. Dust shield |
| 10. Plug | | |
| A. RH side | B. LH side | |

Refer to [GI-9. "Component"](#) and the following for the symbols in the figure.

: NISSAN genuine grease or equivalent

VK45DE models

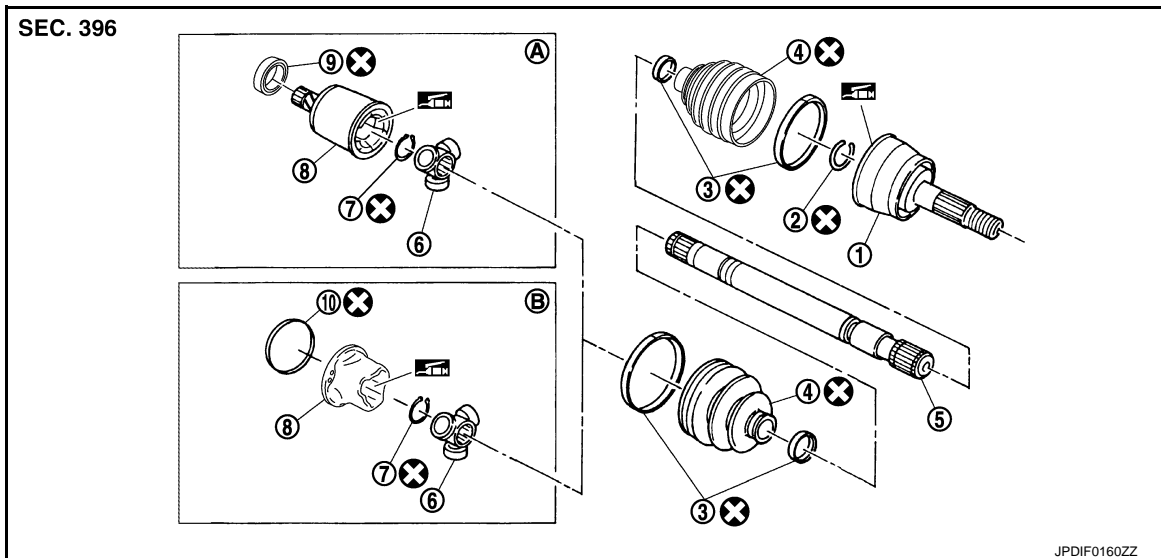

- | | | |
|-----------------------|------------------|--------------------|
| 1. Joint sub-assembly | 2. Circular clip | 3. Boot band |
| 4. Boot | 5. Shaft | 6. Spider assembly |
| 7. Snap ring | 8. Housing | 9. Dust shield |
| 10. Plug | | |
| A. RH side | B. LH side | |

Refer to [GI-9. "Component"](#) and the following for the symbols in the figure.

: NISSAN genuine grease or equivalent

DISASSEMBLY

Front Final Drive Side

FRONT DRIVE SHAFT

< SERVICE INFORMATION >

1. Place shaft in a vise.

CAUTION:

Protect shaft when securing in a vise using aluminum or copper plates.

2. Remove boot bands, and then remove boot from housing.
3. If plug needs to be removed, move boot to wheel side, and drive it out with a plastic hammer. (LH side)
4. Put matching marks on housing and shaft, and then pull out housing from shaft.

CAUTION:

Use paint or similar substance for matching marks. Do not scratch the surfaces.

5. Put matching marks (A) on the shaft and spider assembly.

CAUTION:

Use paint or similar substance for matching marks. Do not scratch the surfaces.

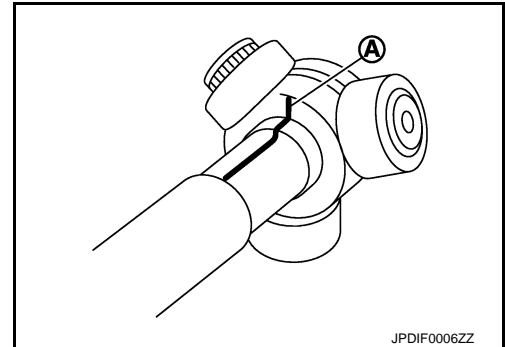

6. Remove snap ring (1). Remove spider assembly from the shaft.
7. Remove boot from the shaft.
8. Remove dust cover from housing. (RH side)
9. Clean old grease on housing with paper towels.

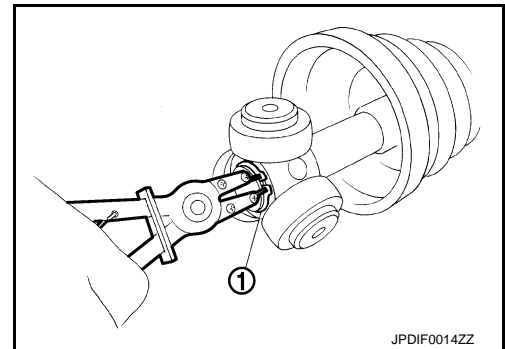

Wheel Side

1. Remove dust shield from drive shaft.
2. Fix shaft with a vise.

CAUTION:

Protect shaft when fixing with a vise using aluminum or copper plates.

3. Remove boot bands. Then remove boot from joint sub-assembly.
4. Screw the drive shaft puller (A) 30 mm (1.18 in) or more into the thread of joint sub-assembly, and pull joint sub-assembly with a sliding hammer (B) from shaft.

CAUTION:

- If joint sub-assembly cannot be removed after five of more unsuccessful attempts, replace shaft and joint sub-assembly as a set.
- Align sliding hammer and drive shaft and remove them by pulling directly.

5. Remove circular clip from shaft.
6. Remove boot from shaft.
7. While rotating ball cage, clean old grease on joint sub-assembly with paper waste.

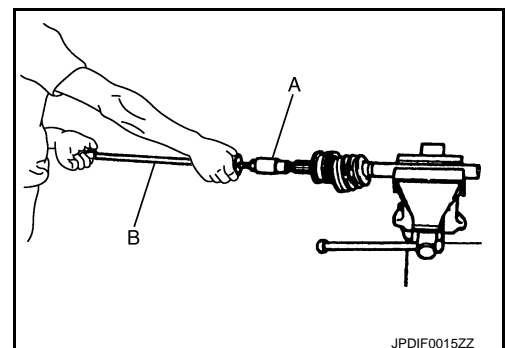

INSPECTION AFTER DISASSEMBLY

Shaft

Check shaft for runout, cracks, or other damage. Replace if there are.

Joint Sub-Assembly (Wheel Side)

Check the following:

A
B
C
FAX
E
F
G
H
I
J
K
L
M
N
O
P

FRONT DRIVE SHAFT

< SERVICE INFORMATION >

- Joint sub-assembly for rough rotation and excessive axial looseness.
 - The inside of the joint sub-assembly for entry of foreign material.
 - Joint sub-assembly for compression scars, cracks, and fractures inside of joint sub-assembly.
- Replace joint sub-assembly if there are any non-standard conditions of components.

Housing and Spider assembly (Front Final Drive side)

Replace housing and spider assembly if there is scratching or wear of housing roller contact surface or spider roller contact surface.

NOTE:

Housing and spider assembly are used in a set.

ASSEMBLY

Front Final Drive Side

1. When installing each plug, refer to the figure and following.
 - If plug (1) has been removed. Install a plug to a housing (2) with a screw. (LH side: VQ35DE)

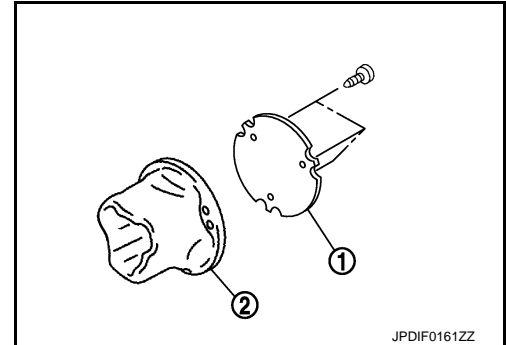

- If plug (1) has been removed use a drift to press in a new one. (LH side: VK45DE)

← : Press

A : Drift [SST: KV38100500 (—)]

B : Drift [SST: KV38102200 (—)]

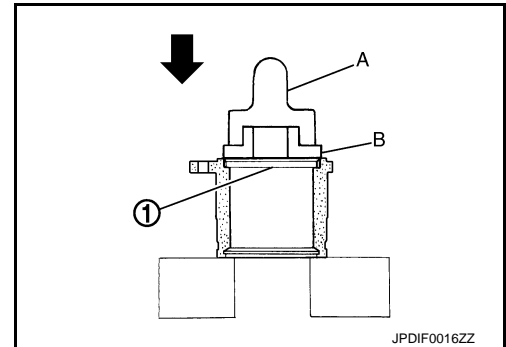

2. Wrap serration on shaft with tape (A) to protect boot from damage. Install new boot and boot bands to shaft.
3. Remove the tape wrapped around the serration on shaft.

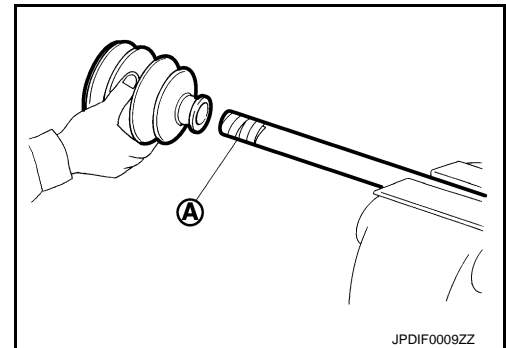

FRONT DRIVE SHAFT

< SERVICE INFORMATION >

- To install the spider assembly (1), align it with the matching marks (A) that were on the shaft (2) during the removal, and direct the serration mounting surface (B) to the shaft.

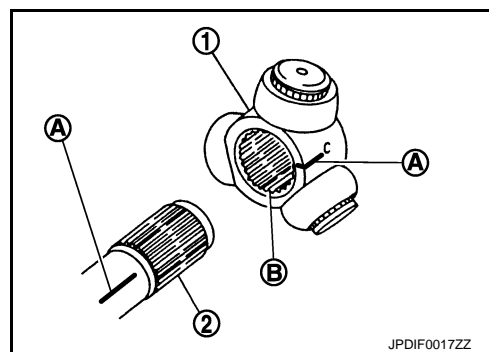

- Secure spider assembly onto shaft with snap ring (1).
- Apply the appropriate amount of grease (NISSAN genuine grease or equivalent) to spider assembly and sliding surface.
- Assemble the housing onto spider assembly, and apply the balance of the specified amount grease (NISSAN genuine grease or equivalent).

Grease amount RH side : Refer to [FAX-19, "Drive Shaft"](#).

LH side : Refer to [FAX-19, "Drive Shaft"](#).

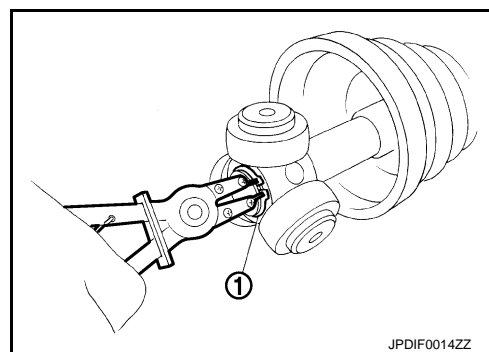

- Install boot securely into grooves (indicated by *marks) shown in the figure.

CAUTION:

If grease adheres to the boot mounting surface (with *mark) on shaft and housing, boot may come off. Remove all grease from the surface.

- To prevent from deformation of the boot, adjust the boot installation length to the value shown below (L) by inserting a flat-bladed screwdriver or similar tool into the inside of boot from the large diameter side of boot and discharging inside air.

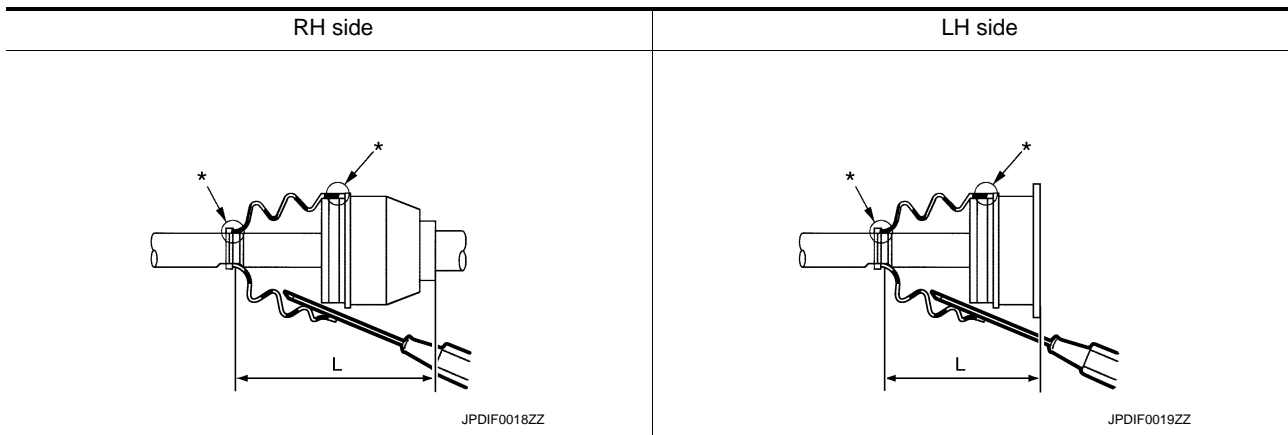

Boot installation length (L) RH side : Refer to [FAX-19, "Drive Shaft"](#).

LH side : Refer to [FAX-19, "Drive Shaft"](#).

CAUTION:

- If the boot installation length is outside the standard, it may cause breakage in boot.
- Be careful not to touch the inside of the boot with the tip of a flat-bladed screwdriver.

- Install new larger and smaller boot bands securely.

- For one-touch clamp band

FRONT DRIVE SHAFT

< SERVICE INFORMATION >

- i. Secure the large and small ends of boot with new boot bands as shown in the figure.

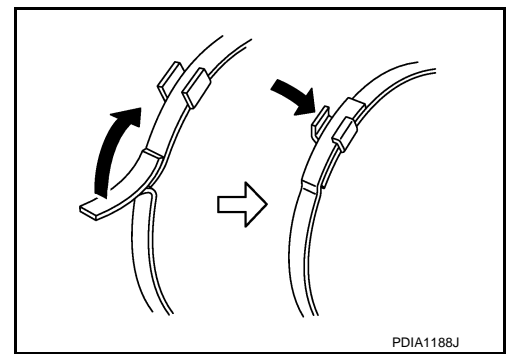

- b. For low profile type band
 - i. Put boot band in the groove on drive shaft boot. Then fit pawls (←) into holes to temporary installation.

NOTE:

For the large diameter side, fit projection (A) and guide slit (B) at first.

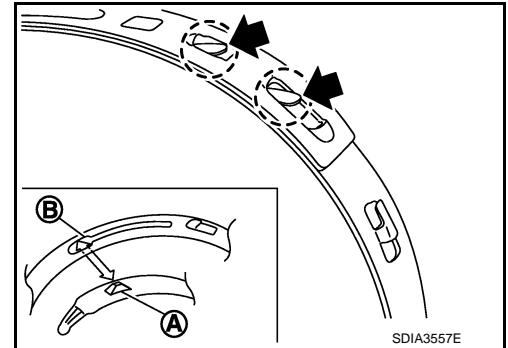

- ii. Pinch projection on the band with suitable pliers to tighten band.
 - iii. Insert tip of band below end of the pawl.
11. Align matching marks painted when housing was removed.
12. Secure housing and shaft, and then make sure that they are in the correct position when rotating boot. Install them with new boot band when the mounting positions become incorrect.
13. Install dust cover to housing. (RH side)

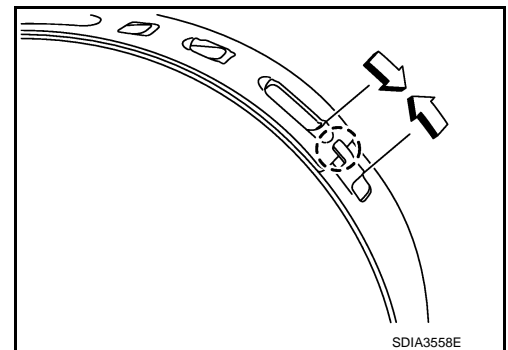

Wheel Side

Assemble in steps 18 to 27 of [FAX-9, "On-Vehicle Inspection"](#), "ON-Vehicle Inspection and Service".

SERVICE DATA AND SPECIFICATIONS (SDS)

< SERVICE INFORMATION >

SERVICE DATA AND SPECIFICATIONS (SDS)

Wheel Bearing

INFOID:000000002955761

Axial end play	0.05 mm (0.002 in) or less
----------------	----------------------------

Drive Shaft

INFOID:000000002955762

VK45DE model

Joint type		Wheel side	Final drive side
Grease quantity	LH side	77 – 97 g (2.72 – 3.42 oz)	95 – 105 g (3.35 – 3.70 oz)
	RH side		113 – 123 g (3.99 – 4.33 oz)
Boots installed length	LH side	136 mm (5.35 in)	149.5 mm (5.89 in)
	RH side		158.6 mm (6.24 in)

VQ35DE model

Joint type		Wheel side	Final drive side
Grease quantity	LH side	77 – 97 g (2.72 – 3.42 oz)	95 – 105 g (3.35 – 3.70 oz)
	RH side		113 – 123 g (3.99 – 4.33 oz)
Boots installed length	LH side	136 mm (5.35 in)	150.9 – 152.9 mm (5.94 – 6.02 in)
	RH side		158.5 mm (6.24 in)

A
B
C
E
F
G
H
I
J
K
L
M
N
O
P

FAX