

SECTION **PB**
PARKING BRAKE SYSTEM

A
B
C
D
E
PB
G
H
I
J
K
L
M
N
O
P

CONTENTS

SERVICE INFORMATION	2	Removal and Installation	4
PREPARATION	2	PARKING BRAKE SHOE	6
Commercial Service Tool	2	Component	6
PARKING BRAKE SYSTEM	3	Removal and Installation	6
On-Vehicle Service	3	SERVICE DATA AND SPECIFICATIONS	
PARKING BRAKE CONTROL	4	(SDS)	9
Component	4	Parking Drum Brake	9
		Parking Brake Control	9

PREPARATION

< SERVICE INFORMATION >

SERVICE INFORMATION

PREPARATION

Commercial Service Tool

INFOID:000000002955904

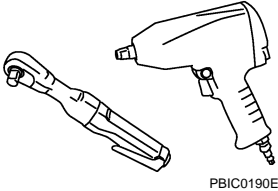
Tool name	Description
Power tool 	Loosening bolts and nuts

PARKING BRAKE SYSTEM

< SERVICE INFORMATION >

PARKING BRAKE SYSTEM

On-Vehicle Service

INFOID:000000002955905

PEDAL STROKE

- Operate parking brake pedal with a force of 196 N (20 kg, 44 lb), make sure pedal stroke is within the specified number of notches. (Check it by listening and counting ratchet clicks.)

Pedal stroke : 3 - 4 notches

INSPECT COMPONENTS

- Make sure that the mounting conditions (looseness, backlash, etc.) of each component are normal.
- Check the following:
 - Device assembly for bend, damage and cracks. Replace if there are.
 - Cables and equalizer for wear and damage. Replace if there are.
 - Parking brake switch. Replace if it does not work correctly.

ADJUSTMENT

- To perform adjustment operations, remove rear tires from vehicle with power tool.

1. Insert a deep socket wrench onto adjusting nut. Rotate adjusting nut to fully loosen cable, and then release parking brake pedal.
2. Secure disc rotor to hub using wheel nut so as not to tilt disc rotor.

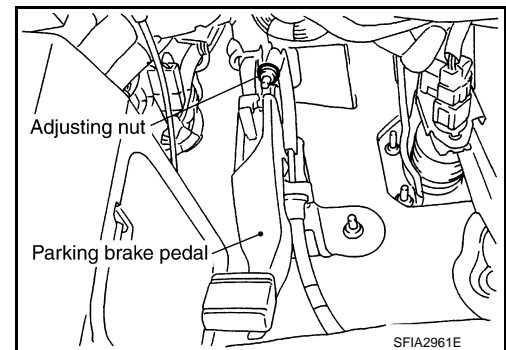

3. Remove adjuster hole plug installed on the disc rotor. Turn the adjuster in direction "A" using a flat-bladed screwdriver as shown, until disc rotor is locked. Turn the adjuster in the opposite direction by 5 or 6 notches after locking.
4. Rotate disc rotor to make sure that there is no drag. Install the adjuster hole plug.
5. Adjust parking brake cable with the following procedure.
 - a. Operate parking brake pedal 10 or more times with the force of 490 N (50 kg, 110lb).
 - b. Rotate adjusting nut to adjust parking brake pedal stroke using a deep socket wrench.

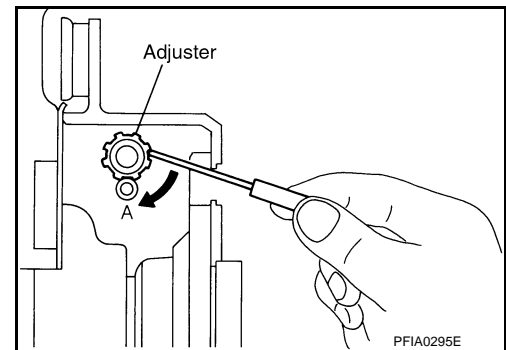

CAUTION:

Do not reuse adjusting nut after removing it.

- c. Operate parking brake pedal with a force of 196 N (20 kg, 44 lb), make sure the pedal stroke is within the specified number of notches. (Check it by listening and counting ratchet clicks.)

Pedal stroke : 3 - 4 notches

- d. Make sure that there is no drag on rear brake with parking brake pedal completely released.

PARKING BRAKE CONTROL

< SERVICE INFORMATION >

PARKING BRAKE CONTROL

Component

INFOID:000000002955906

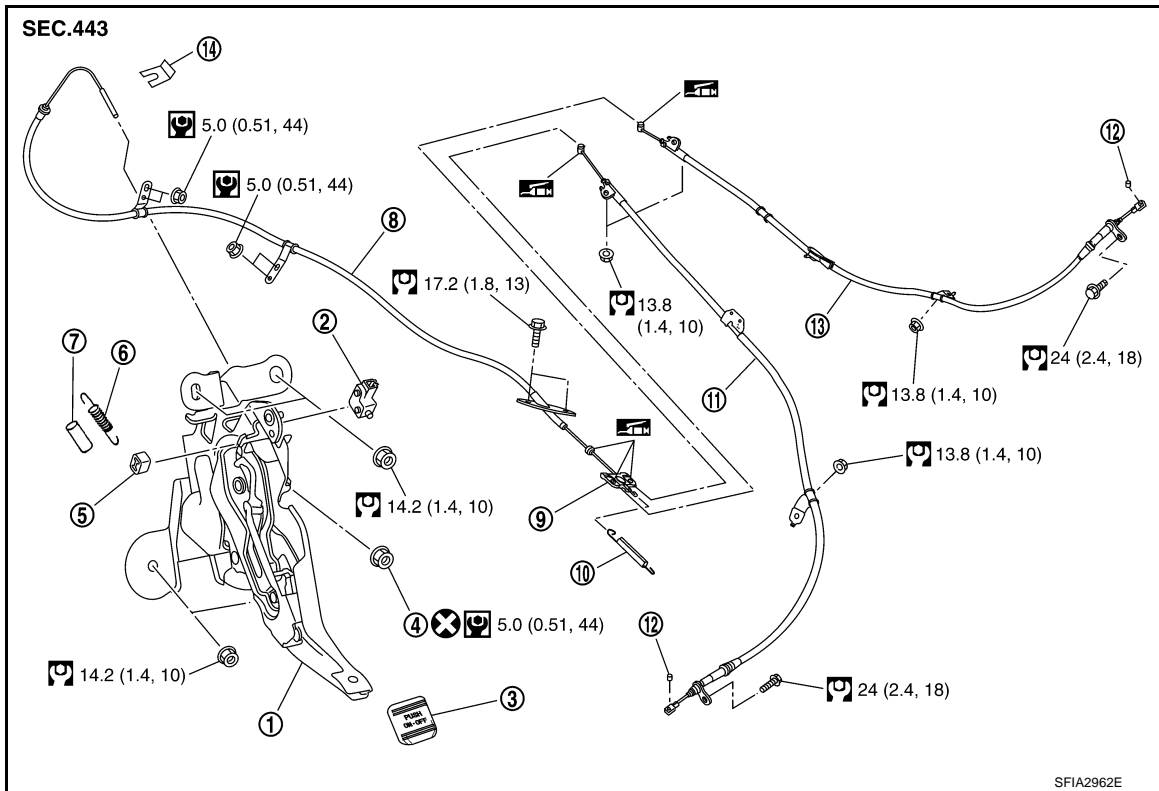

- | | | |
|---------------------|-------------------------|------------------|
| 1. Device assembly | 2. Parking brake switch | 3. Pedal pad |
| 4. Adjusting nut | 5. Stopper rubber | 6. Return spring |
| 7. Spring insulator | 8. Front cable | 9. Equalizer |
| 10. Spring | 11. Rear cable (LH) | 12. Pin |
| 13. Rear cable (RH) | 14. Lock plate | |

Refer to [GI-9, "Component"](#) and the followings for the symbols in the figure.

 : Apply Multi-purpose grease.

Removal and Installation

INFOID:000000002955907

REMOVAL

1. Release parking brake.
2. Remove rear tires from vehicle with power tool.
3. Remove instrument driver lower panel. Refer to [IP-11](#).
4. Disconnect parking brake switch connector.
5. Remove adjusting nut and loosen front cable.
6. Remove device assembly mounting nuts and remove device assembly from vehicle.
7. Remove center console. Refer to [IP-21, "CENTER CONSOLE : Component Parts Location"](#).
8. Separate rear cable from front cable, remove front cable from vehicle.
9. Remove heat insulator of the exhaust center muffler from vehicle.
10. Remove parking brake shoe, and remove rear cable from toggle lever. Refer to [PB-6, "Removal and Installation"](#).
11. Remove rear cable mounting bolts and nuts, pull out rear cable from vehicle.

INSTALLATION

PARKING BRAKE CONTROL

< SERVICE INFORMATION >

1. Install in the reverse order of the removal. Refer to [PB-4, "Component"](#) for tightening torque.
CAUTION:
Do not reuse adjusting nut.
2. Adjust parking brake. Refer to [PB-3, "On-Vehicle Service"](#).

A

B

C

D

E

PB

G

H

I

J

K

L

M

N

O

P

PARKING BRAKE SHOE

< SERVICE INFORMATION >

PARKING BRAKE SHOE

Component

INFOID:000000002955908

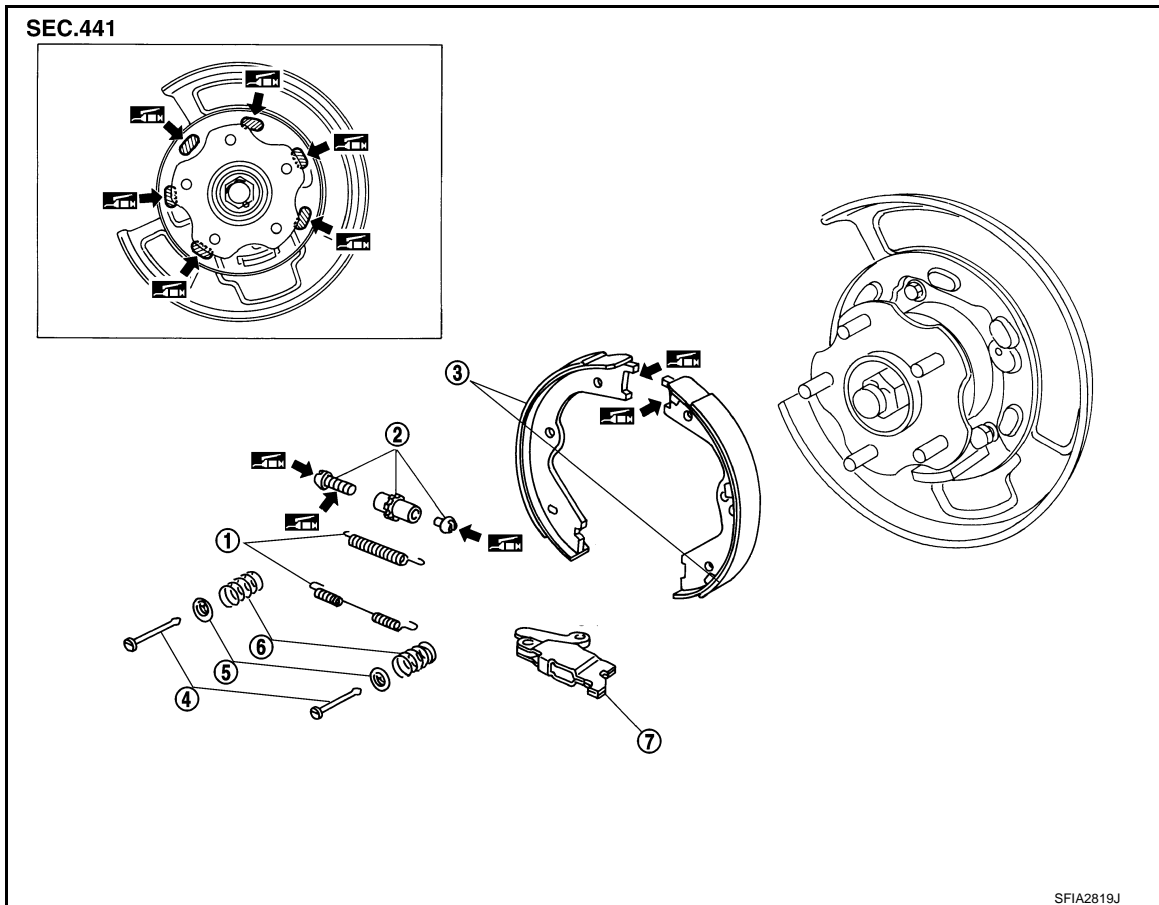

- | | | |
|--------------------|-------------|-----------------------|
| 1. Return spring | 2. Adjuster | 3. Brake shoe |
| 4. Anti-rattle pin | 5. Retainer | 6. Anti-rattle spring |
| 7. Toggle lever | | |

 : Apply PBC (Poly Butyl Cuprysil) grease or silicone-based grease.

Removal and Installation

INFOID:000000002955909

REMOVAL

WARNING:

Clean brakes with a vacuum dust collector to minimize the hazard of air borne particles or other materials.

CAUTION:

- Clean dust on disc rotor and back plate using a vacuum dust collector. Do not blow with compressed air.
- Put matching marks on both disc rotor and wheel hub when removing disc rotor.

1. Remove rear tires from vehicle with power tool.
2. Remove disc rotor with parking brake pedal completely in the released position. Refer to [BR-28, "Removal and Installation of Brake Caliper Assembly"](#).
3. If disc rotor cannot be removed, remove as follows:
 - a. Secure the disc rotor in place with wheel nuts and remove adjuster hole plug.

PARKING BRAKE SHOE

< SERVICE INFORMATION >

- b. Using a flat-bladed screwdriver, rotate adjuster in direction "B" to retract and loosen brake shoe.
4. Remove anti-rattle pins, retainers, anti-rattle springs, and return springs.
5. Remove parking brake shoes, adjuster assembly, and toggle lever.
6. For the removal of back plate, refer to [RAX-5. "Removal and Installation"](#).

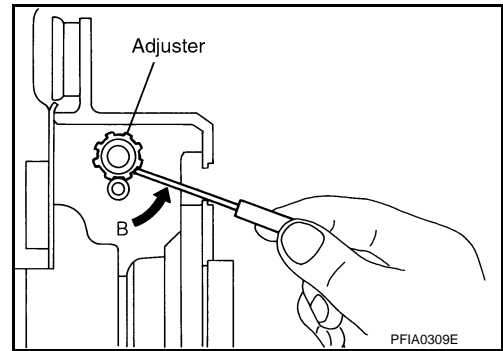

INSPECTION AFTER REMOVAL

Lining Thickness Inspection

- Check thickness of lining.

Standard thickness "A"	: 3.2 mm (0.126 in)
Repair limit thickness "A"	: 1.5 mm (0.059 in)

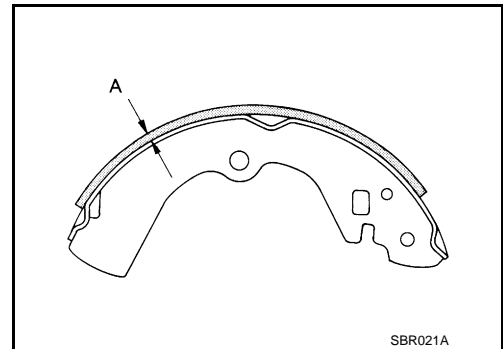

Drum Inner Diameter Inspection

- Check inner diameter of drum.

Standard inner diameter	: 172 mm (6.77 in) dia.
Maximum inner diameter	: 173 mm (6.81 in) dia.

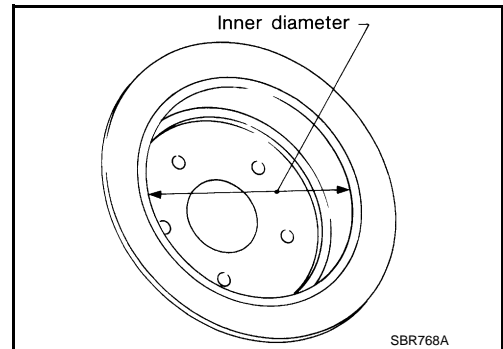

Other Inspections

- Check the following:
 - Lining for excessive wear, damage, and peeling.
 - Shoe sliding surface for excessive wear and damage.
 - Anti-rattle pin for excessive wear and corrosion.
 - Return spring for sagging.
- Make sure that adjuster moves smoothly.
- Visually check the inside of drum for excessive wear, cracks, and damage. Check the inside of drum using a pair of vernier calipers.
- Replace with new part if the above part is malfunction.

INSTALLATION

Note the following, and install in the reverse order of removal.

PARKING BRAKE SHOE

< SERVICE INFORMATION >

- Refer to [PB-6. "Component"](#) and apply PBC (Poly Butyl Cuprysil) grease or silicone-based grease to the specified points during assembly.
 - Assemble adjusters so that threaded part is expanded when rotating it in the direction shown by arrow.
 - Shorten adjuster by rotating it.
 - Check shoe sliding surface and drum inner surface for grease. Wipe it off if it adhere on the surfaces.
 - Perform break-in operation as follows after replacing brake shoes or disc rotors, or if brakes do not function well.
1. Adjust parking brake pedal stroke to the specified amount. Refer to [PB-3. "On-Vehicle Service"](#).
 2. Perform parking brake break-in (drag run) operation by driving vehicle under the following conditions:

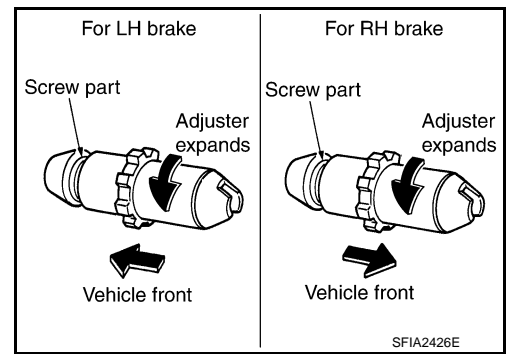

Drive forward

- **Vehicle speed: Approx. 40 km/h (25 MPH) set (constant and forward)**
 - **Parking brake operating force: Approx. 400 N (40 kg, 89.9 lb) set constant**
 - **Time: Approx. 10 sec.**
3. Check parking brake pedal stroke of parking brake. Adjust again if it is outside the standard.

SERVICE DATA AND SPECIFICATIONS (SDS)

< SERVICE INFORMATION >

SERVICE DATA AND SPECIFICATIONS (SDS)

Parking Drum Brake

INFOID:000000002955910

Brake lining	Standard thickness	3.2 mm (0.126 in)
	Repair limit thickness	1.5 mm (0.059 in)
Drum (disc)	Standard inner diameter	172 mm (6.77 in) dia.
	Maximum inner diameter	173 mm (6.81 in) dia.

Parking Brake Control

INFOID:000000002955911

Control type	Foot pedal
Number of notches [under force of 196 N (20 kg, 44 lb)]	3 – 4 notches
Number of notches when parking brake warning lamp comes on	1 notch

A

B

C

D

E

PB

G

H

I

J

K

L

M

N

O

P