

SECTION **SB**
SEAT BELTS

A
B
C
D
E
F
G
SB
I
J
K
L
M
N
O
P

CONTENTS

SERVICE INFORMATION	2	Check Motor Power Supply and Ground Circuit [B2454]	17
DTC INDEX	2	Check Seat Belt Buckle Switch (Driver Side) Circuit	18
U1000	2	Check Seat Belt Buckle Switch (Passenger Side) Circuit	19
B2451 - B2455	2	Check Brake Pedal Stroke Sensor Circuit [B2453]...21	
PRECAUTIONS	3	Check Pre-Crash Seat Belt Motor LH Circuit [B2452]	23
Precaution for Supplemental Restraint System (SRS) "AIR BAG" and "SEAT BELT PRE-TENSIONER"	3	Check Pre-Crash Seat Belt Motor RH Circuit [B2451]	24
Precaution for Seat Belt Service	3	Check Brake Pedal Stroke Sensor Shield Wire Circuit	25
PRE-CRASH SEAT BELT	5	Removal and Installation of Pre-Crash Seat Belt Control Unit	25
Component Parts and Harness Connector Location	5	SEAT BELTS	27
System Description	5	System Description	27
CAN Communication System Description	6	Removal and Installation of Front Seat Belt	27
CAN Communication Unit	6	Removal and Installation of Rear Seat Belt	29
Schematic	7	Seat Belt Inspection	30
Wiring Diagram - PSB -	8	LATCH (LOWER ANCHORS AND TETHER FOR CHILDREN) SYSTEM	33
Terminal and Reference Value for Pre-Crash Seat Belt Control Unit	13	Removal and Installation	33
Work Flow	14	TOP TETHER STRAP CHILD RESTRAINT	34
CONSULT-III Function (PRECRASH SEATBELT)	14	Removal and Installation	34
Preliminary Check	15		
Diagnosis Symptom Chart	15		
Check CAN Communication Circuit [U1000]	16		
Check Ignition Power Supply Circuit	16		

DTC INDEX

< SERVICE INFORMATION >

SERVICE INFORMATION

DTC INDEX

U1000

INFOID:000000003319359

CONSULT display	DTC detection condition	Reference page
U1000: CAN COMM CIRCUIT	When pre-crash seat belt control unit is not transmitting or receiving CAN communication signal for 2 seconds or more.	SB-16, "Check CAN Communication Circuit [U1000]".

B2451 - B2455

INFOID:000000003319360

CONSULT display	DTC detection condition	Reference page
B2451: SB MOTOR RH CIRCUIT	Circuit of seat belt motor (RH) is open or shorted.	SB-24, "Check Pre-Crash Seat Belt Motor RH Circuit [B2451]".
B2452: SB MOTOR LH CIRCUIT	Circuit of seat belt motor (LH) is open or shorted.	SB-23, "Check Pre-Crash Seat Belt Motor LH Circuit [B2452]".
B2453: BR STROKE SEN CIRC	Circuit of brake pedal stroke sensor is open or shorted.	SB-21, "Check Brake Pedal Stroke Sensor Circuit [B2453]".
B2454: MOTOR PWR SUP CIRC	Circuit of motor power supply is open or shorted.	SB-17, "Check Motor Power Supply and Ground Circuit [B2454]".
B2455: PSB C/U INT SIRC	ECU circuit internal abnormality.	—

PRECAUTIONS

< SERVICE INFORMATION >

PRECAUTIONS

Precaution for Supplemental Restraint System (SRS) "AIR BAG" and "SEAT BELT PRE-TENSIONER"

INFOID:000000005155276

The Supplemental Restraint System such as "AIR BAG" and "SEAT BELT PRE-TENSIONER", used along with a front seat belt, helps to reduce the risk or severity of injury to the driver and front passenger for certain types of collision. This system includes seat belt switch inputs and dual stage front air bag modules. The SRS system uses the seat belt switches to determine the front air bag deployment, and may only deploy one front air bag, depending on the severity of a collision and whether the front occupants are belted or unbelted. Information necessary to service the system safely is included in the "SUPPLEMENTAL RESTRAINT SYSTEM" and "SEAT BELTS" of this Service Manual.

WARNING:

- To avoid rendering the SRS inoperative, which could increase the risk of personal injury or death in the event of a collision which would result in air bag inflation, all maintenance must be performed by an authorized NISSAN/INFINITI dealer.
- Improper maintenance, including incorrect removal and installation of the SRS, can lead to personal injury caused by unintentional activation of the system. For removal of Spiral Cable and Air Bag Module, see the "SUPPLEMENTAL RESTRAINT SYSTEM".
- Do not use electrical test equipment on any circuit related to the SRS unless instructed to in this Service Manual. SRS wiring harnesses can be identified by yellow and/or orange harnesses or harness connectors.

PRECAUTIONS WHEN USING POWER TOOLS (AIR OR ELECTRIC) AND HAMMERS

WARNING:

- When working near the Air Bag Diagnosis Sensor Unit or other Air Bag System sensors with the ignition ON or engine running, DO NOT use air or electric power tools or strike near the sensor(s) with a hammer. Heavy vibration could activate the sensor(s) and deploy the air bag(s), possibly causing serious injury.
- When using air or electric power tools or hammers, always switch the ignition OFF, disconnect the battery, and wait at least 3 minutes before performing any service.

Precaution for Seat Belt Service

INFOID:000000002956036

CAUTION:

- Before removing the front seat belt pre-tensioner assembly, turn the ignition switch off, disconnect the both battery cables and wait at least 3 minutes.
- Do not use electrical test equipment for front seat belt pre-tensioner connector.
- After replacing or reinstalling front seat belt pre-tensioner assembly, or reconnecting front seat belt pre-tensioner connector, check the system function. Refer to [SRS-22, "SRS Operation Check \(USER MODE\)"](#).
- Do not use disassemble buckle or seat belt assembly.
- Replace anchor bolts if they are deformed or worn out.
- Never oil tongue and buckle.
- If any component of seat belt assembly is questionable, do not repair. Replace the whole seat belt assembly.
- If webbing is cut, frayed, or damaged, replace seat belt assembly.
- When replacing seat belt assembly, use a genuine NISSAN seat belt assembly.

AFTER A COLLISION

WARNING:

Inspect all seat belt assemblies including retractors and attaching hardware after any collision. NISSAN recommends that all seat belt assemblies in use during a collision be replaced unless the collision was minor and the belts show no damage and continue to operate properly. Failure to do so could result in serious personal injury in an accident. Seat belt assemblies not in use during a collision should also be replaced if either damage or improper operation is noted. Seat belt pre-tensioner should be replaced even if the seat belts are not in use during a frontal collision in which the air bags are deployed.

Replace any seat belt assembly (including anchor bolts) if:

- The seat belt was in use at the time of a collision (except for minor collisions and the belts, retractors and buckles show no damage and continue to operate properly).

A

B

C

D

E

F

G

SB

I

J

K

L

M

N

O

P

PRECAUTIONS

< SERVICE INFORMATION >

- The seat belt was damaged in an accident. (i.e. torn webbing, bent retractor or guide).
- The seat belt attaching point was damaged in an accident. Inspect the seat belt attaching area for damage or distortion and repair as necessary before installing a new seat belt assembly.
- Anchor bolts are deformed or worn out.
- The front seat belt pre-tensioner should be replaced even if the seat belts are not in use during the collision in which the air bags are deployed.

PRE-CRASH SEAT BELT

< SERVICE INFORMATION >

PRE-CRASH SEAT BELT

Component Parts and Harness Connector Location

INFOID:00000002956037

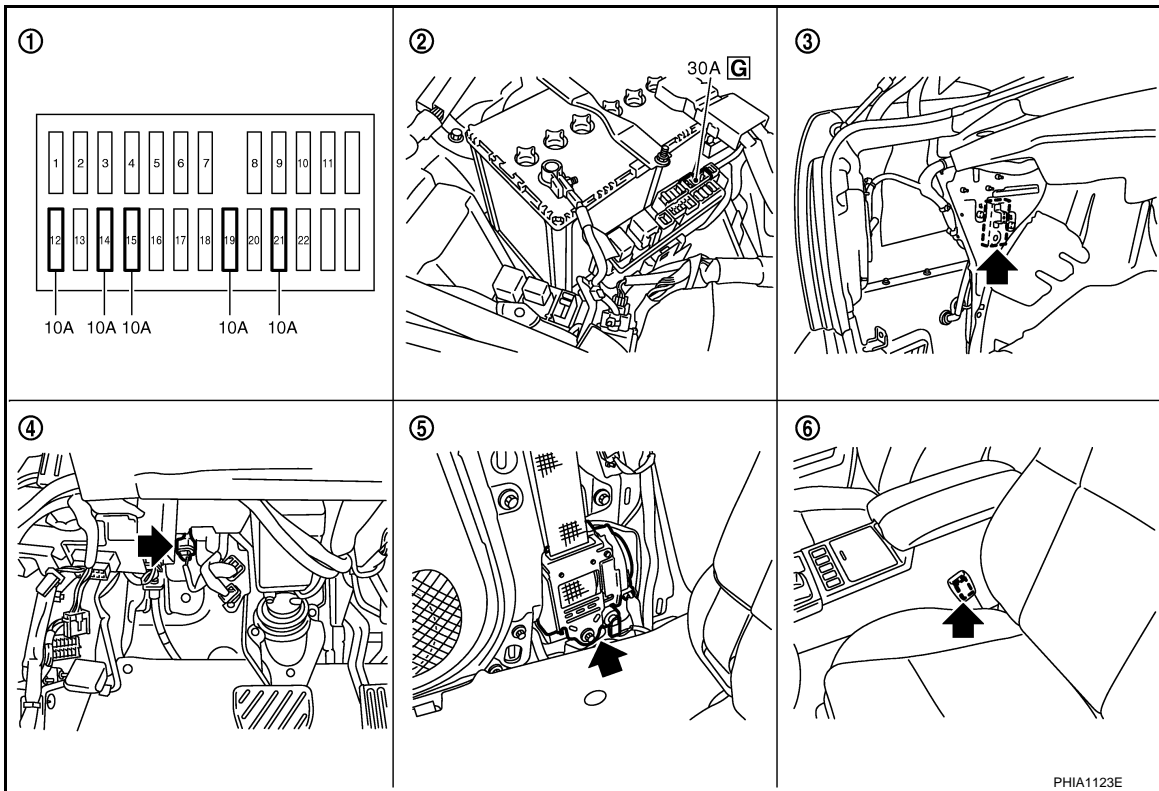

1. Fuse block (J/B)
2. Fuse, fusible link and relay block (J/B)
3. Pre-crash seat belt control unit B142 (View with the trunk side finisher LH removed)
4. Brake pedal stroke sensor E125 (View with the instrument driver low-panel removed)
5. Pre-crash seat belt motor B32 (LH), B422 (RH) (View with the center pillar lower garnish removed)
6. Seat belt buckle switch B203 (driver seat) B253 (passenger seat)

System Description

INFOID:00000002956038

- Pre-crash seat belt system is adapted to front seat belts RH/LH.
- When the pre-crash seat belt control unit judges the emergency braking operation, it gives the sense of security by the motor built into the pre-crash seat belt retracting the shoulder belt and suppressing the crew's posture change. Also, it eases the damage of the collision.

FUNCTION DESCRIPTION

Operation condition

Pre-crash seat belt operates under the following conditions.

Condition	<ul style="list-style-type: none"> • When the brake pedal is depressed more than a certain extent • When operation prohibition condition is not satisfied
-----------	---

Operation prohibition condition

If operation condition is satisfied, pre-crash seat belt does not operate under the following conditions.

Condition	<ul style="list-style-type: none"> • When seat belt is not fastened (Only the seat belt that is not fastened does not operate.) • When vehicle is moving backwards • When the vehicle speed is 15 km/h (9 MPH) or less • When pre-crash seat belt continuously operates 3 times or more *1 • At fail-safe condition *2
-----------	---

PRE-CRASH SEAT BELT

< SERVICE INFORMATION >

*1: When pre-crash seat belt doesn't operate after it continuously operates 3 times or more, operation can be performed again by stopping operation for approximately 7 minutes.

*2: Refer to "FAIL-SAFE MODE" for details of fail-safe mode.

FAIL-SAFE MODE

When a malfunction occurs in the following system, the pre-crash seat belt function is controlled according to the malfunctioning parts.

Also, seat belt warning lamp blinks with fastening driver seat belt when the following malfunction occurs.

Malfunctioning parts	Control contents
Brake pedal stroke sensor system malfunction	Pre-crash seat belt RH/LH do not activate when emergency brake operates.
Seat belt motor RH malfunction	Pre-crash seat belt RH does not activate.
Seat belt motor LH malfunction	Pre-crash seat belt LH does not activate.
Motor power supply circuit malfunction	Pre-crash seat belt RH/LH do not activate.

Seat Belt Warning Lamp Illumination Pattern

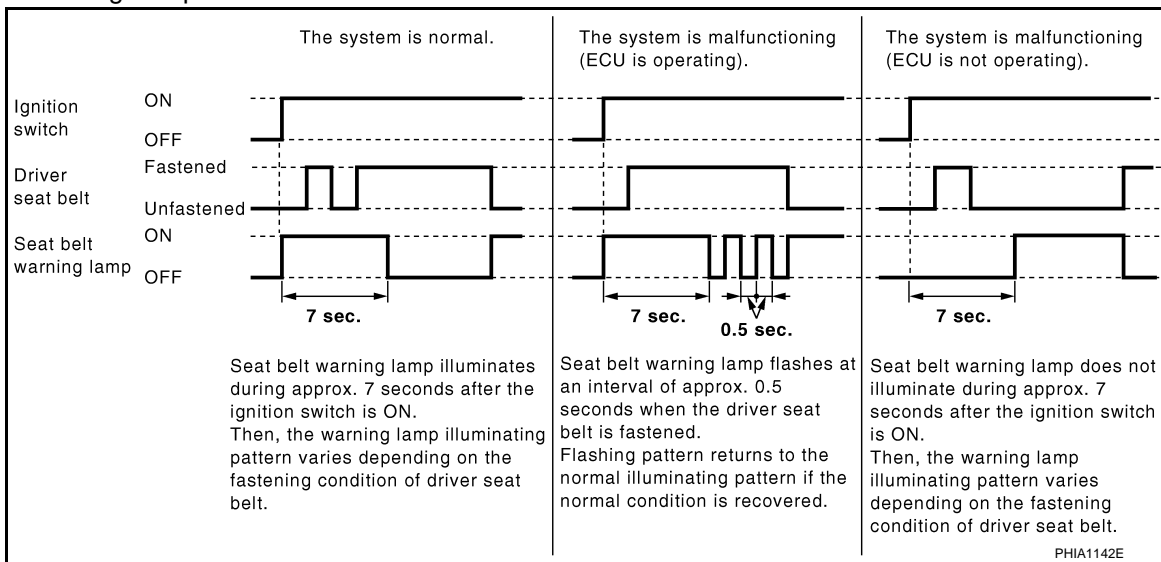

NOTE:

The seat belt warning lamp illumination system shown above operates only when the air bag system does not turn on the seat belt warning lamp. The air bag system turns on the seat belt warning lamp, depending on the conditions of passenger being on and the passenger seat belt fastening.

CAN Communication System Description

INFOID:000000002956039

CAN (Controller Area Network) is a serial communication line for real time application. It is an on-vehicle multiplex communication line with high data communication speed and excellent error detection ability. Many electronic control units are equipped onto a vehicle, and each control unit shares information and links with other control units during operation (not independent). In CAN communication, control units are connected with 2 communication lines (CAN H line, CAN L line) allowing a high rate of information transmission with less wiring. Each control unit transmits/receives data but selectively reads required data only.

CAN Communication Unit

INFOID:000000002956040

Refer to [LAN-29. "CAN System Specification Chart"](#).

PRE-CRASH SEAT BELT

< SERVICE INFORMATION >

Schematic

INFOID:00000002956041

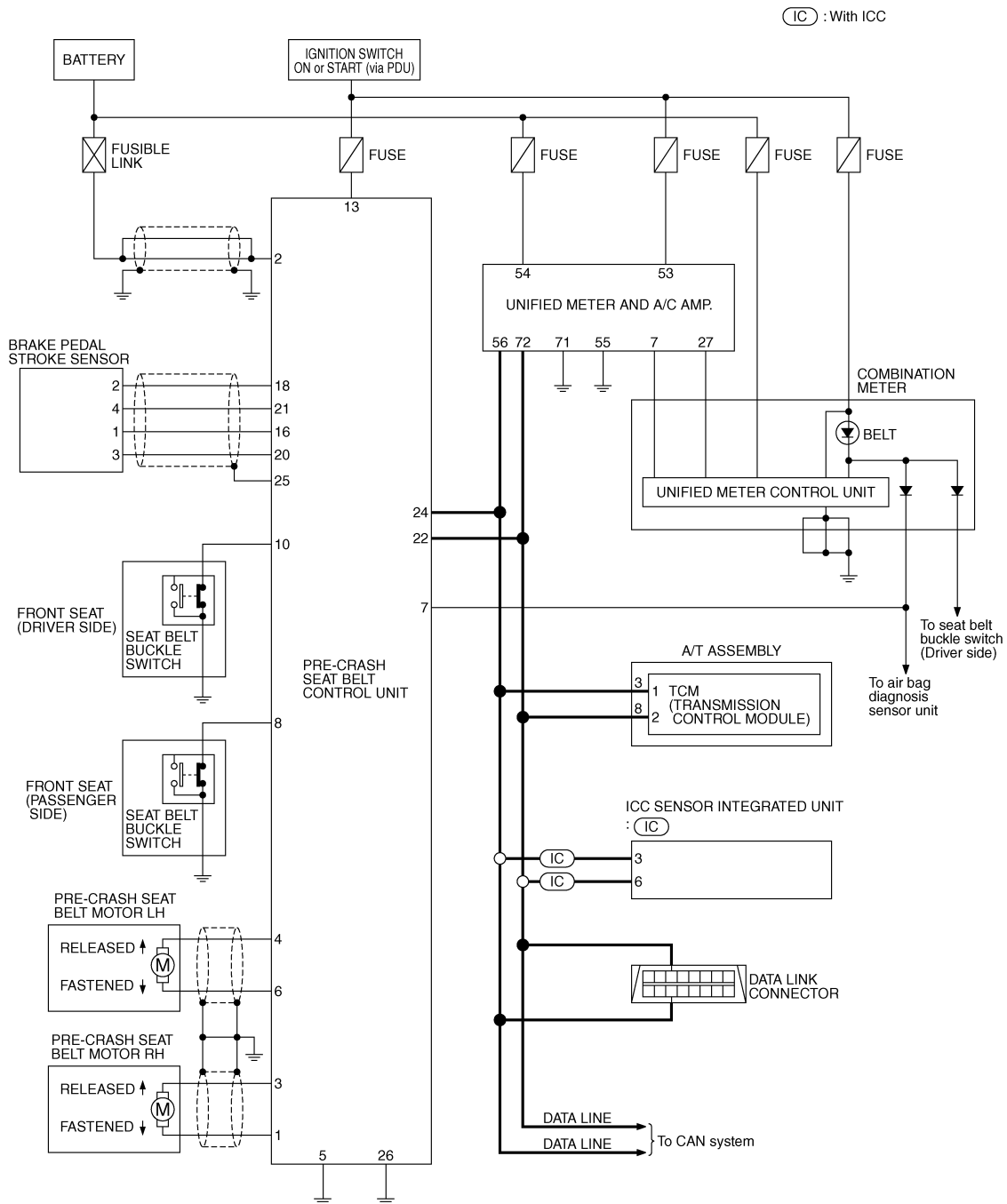

A
B
C
D
E
F
G
SB
I
J
K
L
M
N
O
P

THWT0139E

PRE-CRASH SEAT BELT

< SERVICE INFORMATION >

Wiring Diagram - PSB -

INFOID:000000002956042

SB-PSB-01

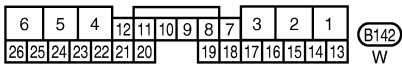
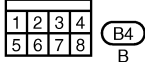
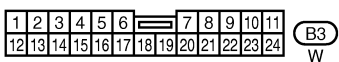
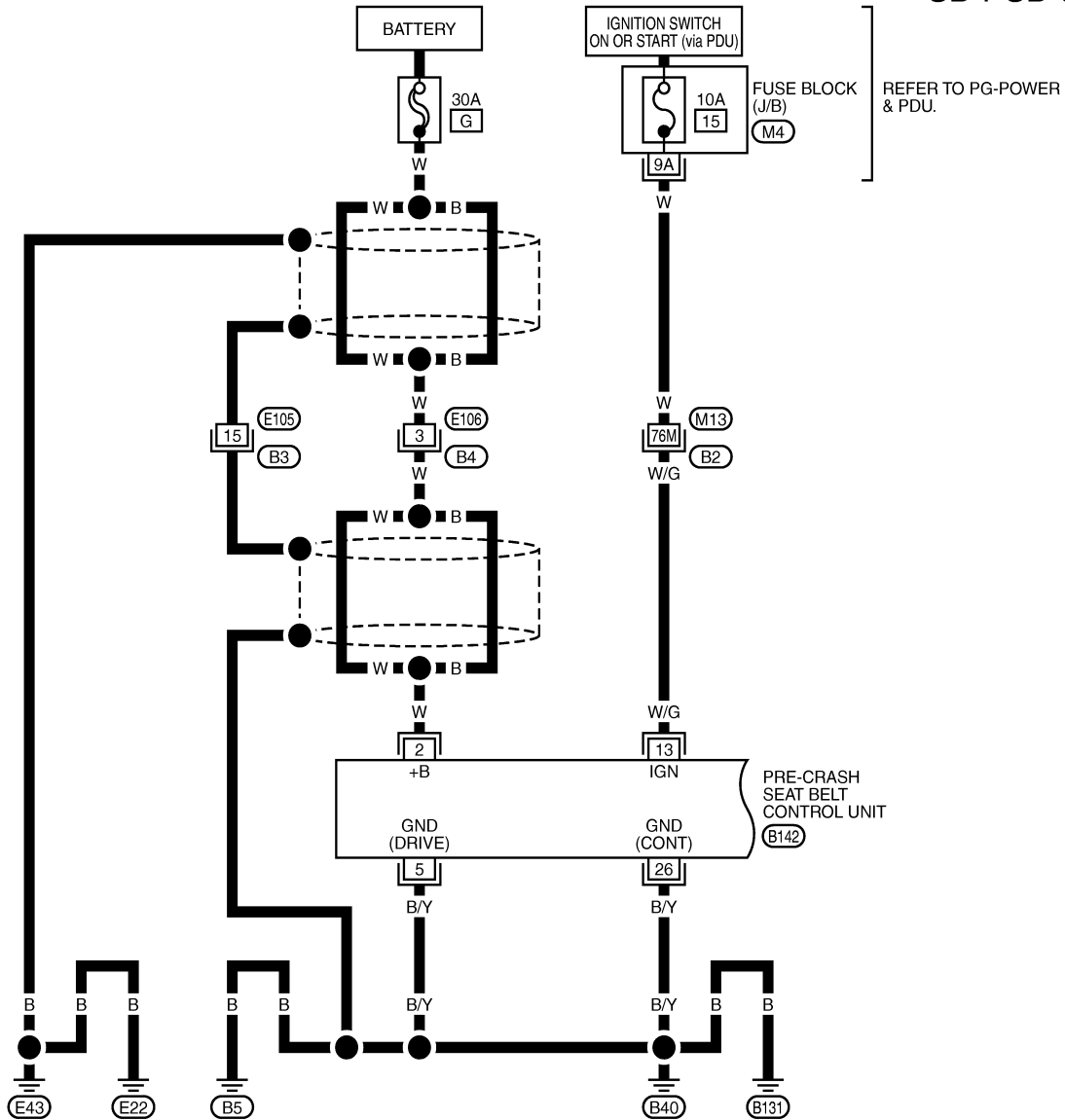

REFER TO THE FOLLOWING.
 (B2) - SUPER MULTIPLE JUNCTION (SMJ)
 (M4) - FUSE BLOCK - JUNCTION BOX (J/B)

THWT0308E

PRE-CRASH SEAT BELT

< SERVICE INFORMATION >

SB-PSB-02

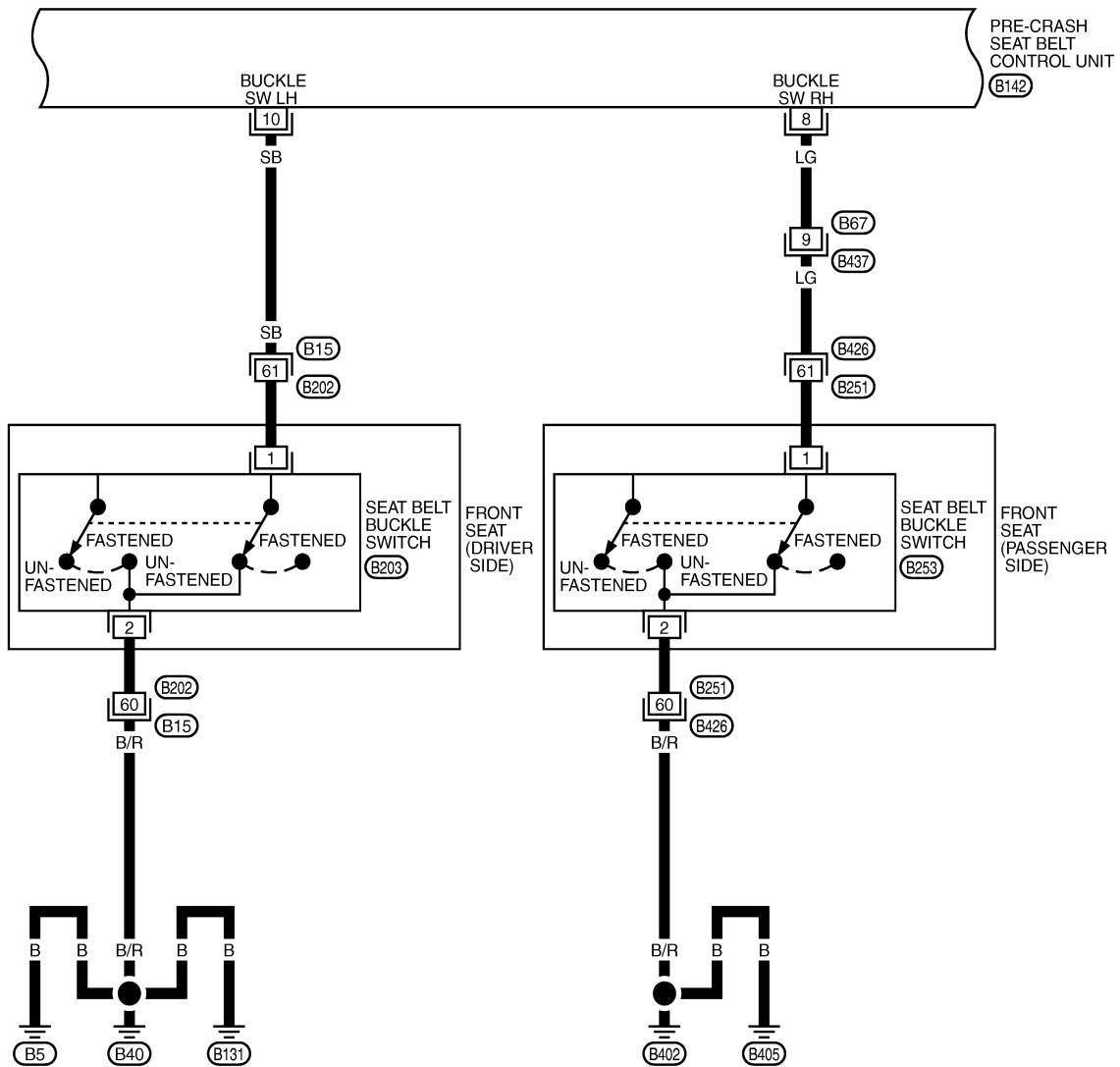

19	3	1	17	40	
61	60	59	32	48	21

(B15)
W

6	5	4	12	11	10	9	8	7	3	2	1		
26	25	24	23	22	21	20	19	18	17	16	15	14	13

(B142)
W

1	*	*
2	(B203)	(B253)
3	B	B

80	55	54	7	61	60	59	53	52	51
16	58	4	57	5	48	6	33		

(B426)
W

1	2	3	4	5	6	7	8	9	10	11		
12	13	14	15	16	17	18	19	20	21	22	23	24

(B437)
BR

*: THIS CONNECTOR IS NOT SHOWN IN "HARNESS LAYOUT", PG SECTION.

THWT0309E

A
B
C
D
E
F
G
SB
I
J
K
L
M
N
O
P

PRE-CRASH SEAT BELT

< SERVICE INFORMATION >

SB-PSB-03

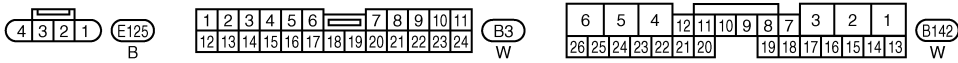
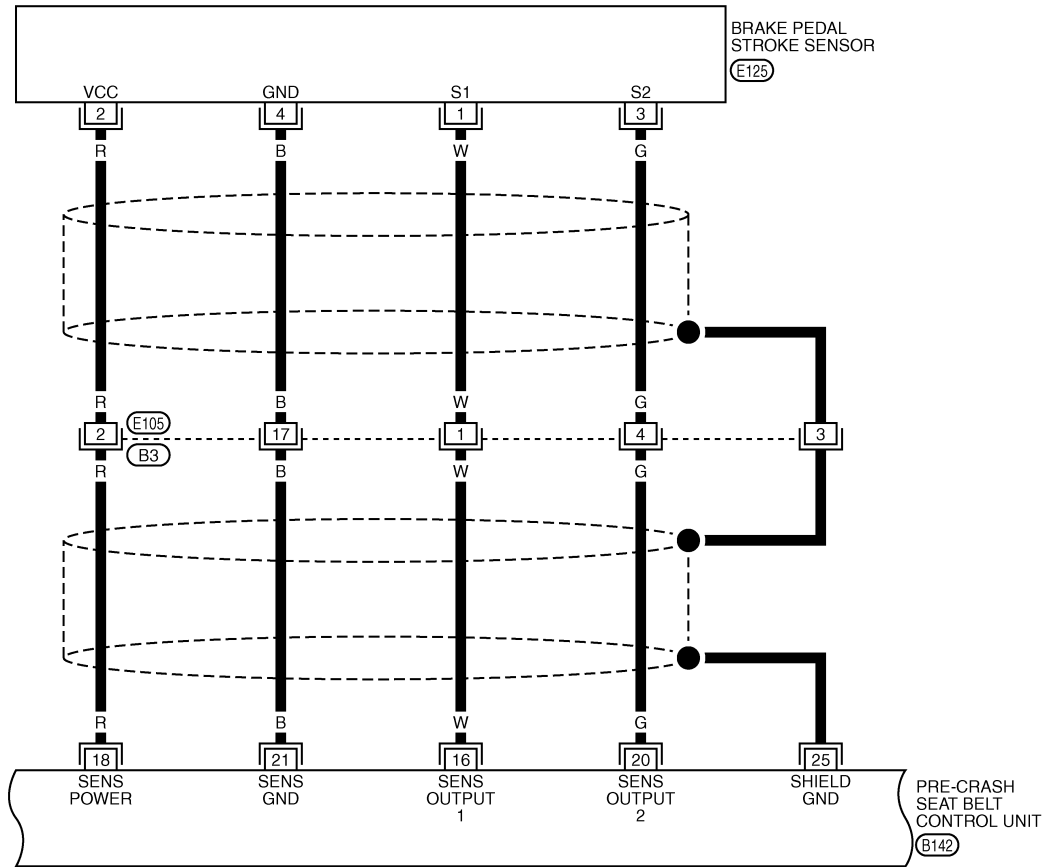

THWT0142E

PRE-CRASH SEAT BELT

< SERVICE INFORMATION >

SB-PSB-04

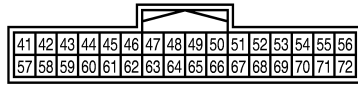
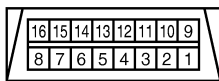
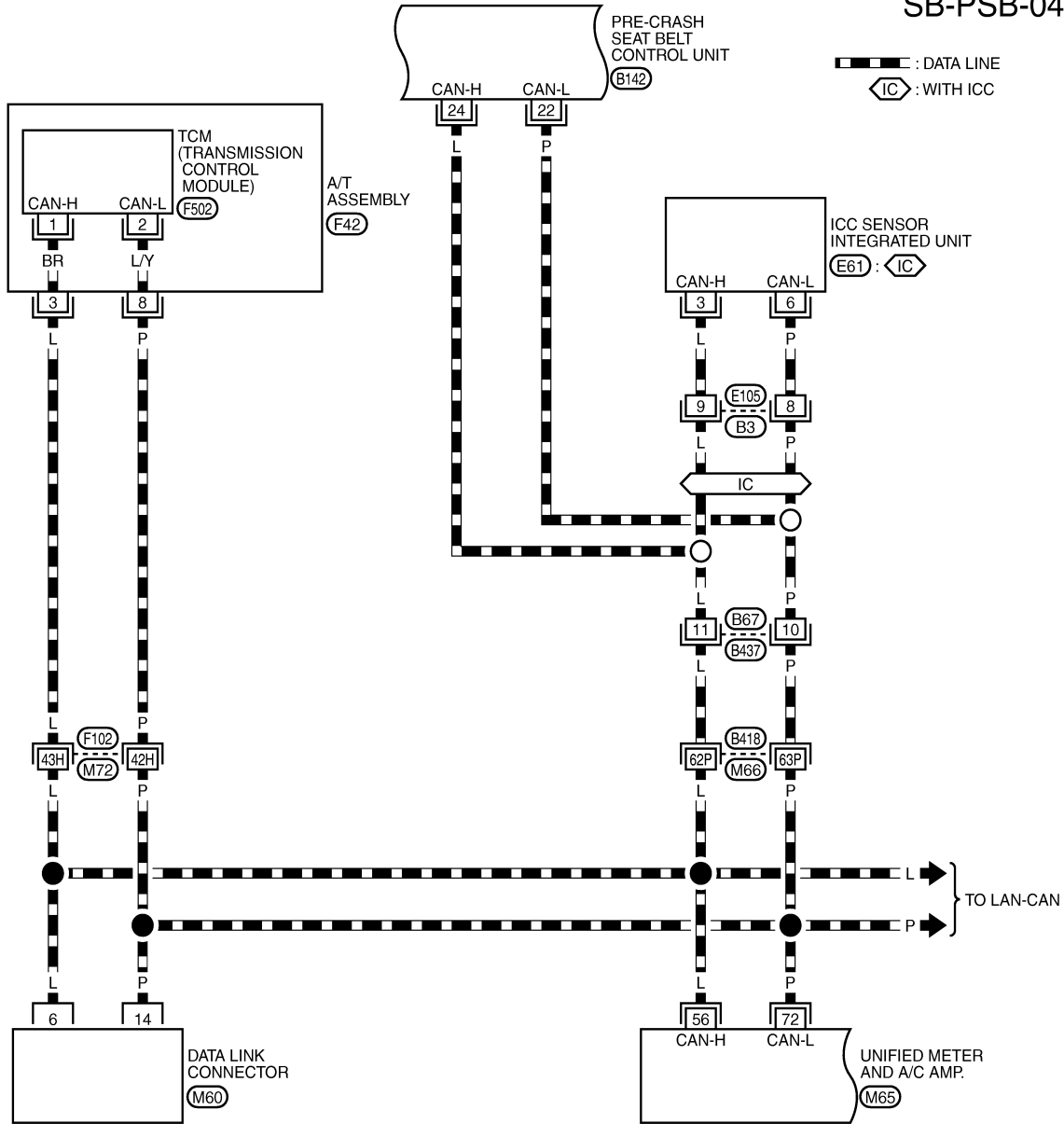

REFER TO THE FOLLOWING.
 (F102), (B418) - SUPER MULTIPLE JUNCTION (SMJ)

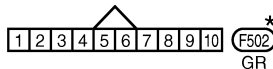
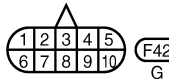
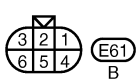

*: THIS CONNECTOR IS NOT SHOWN IN "HARNESS LAYOUT", PG. SECTION.

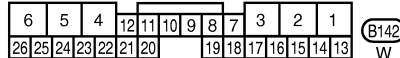
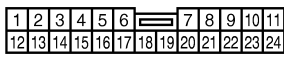

THWT0310E

A
B
C
D
E
F
G
SB
I
J
K
L
M
N
O
P

PRE-CRASH SEAT BELT

< SERVICE INFORMATION >

SB-PSB-05

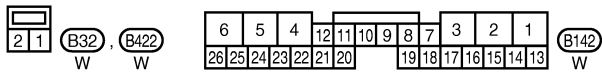
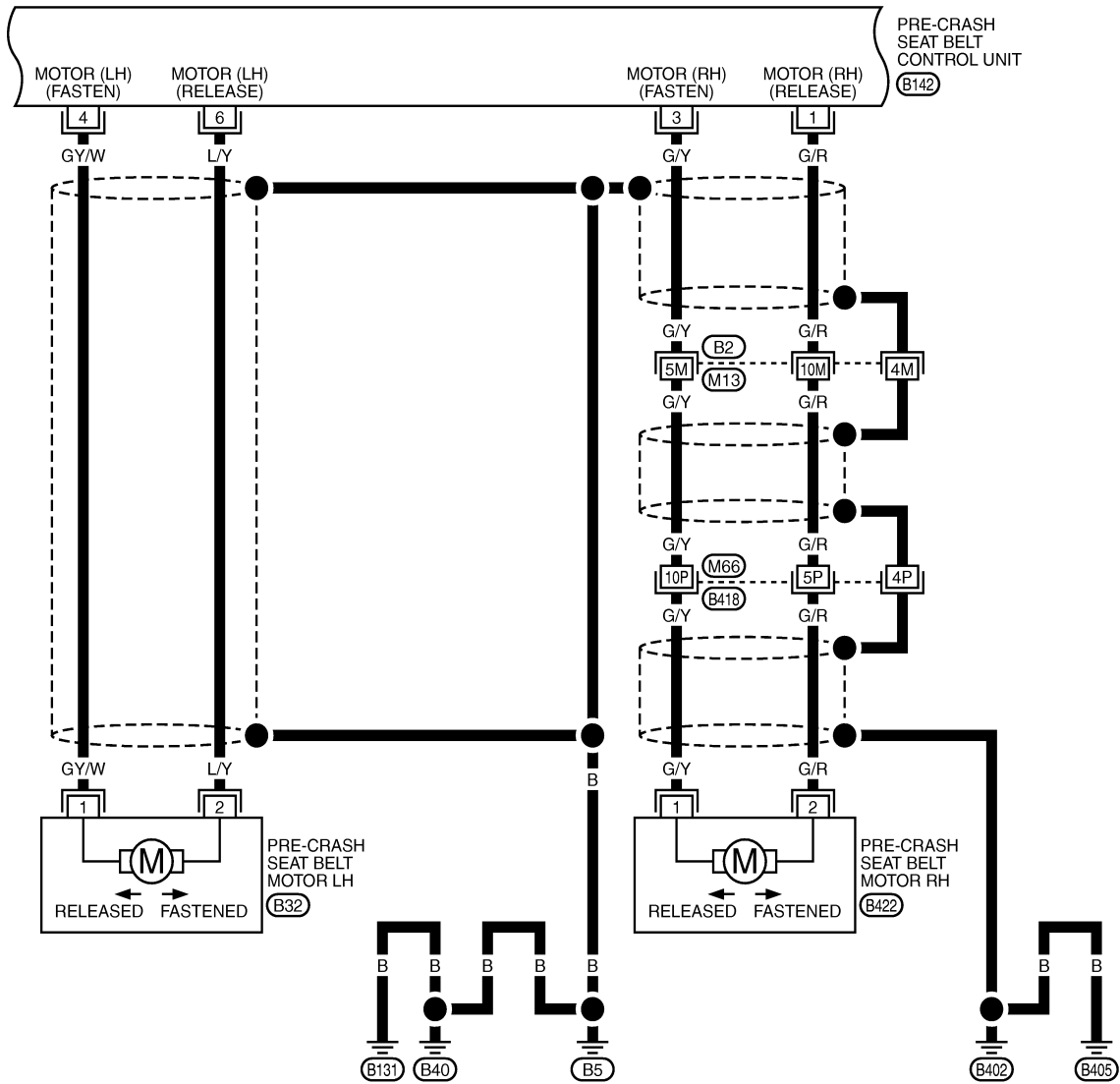

REFER TO THE FOLLOWING.
 (B2), (B418) - SUPER MULTIPLE JUNCTION (SMJ)

THWT0311E

PRE-CRASH SEAT BELT

< SERVICE INFORMATION >

SB-PSB-06

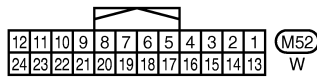
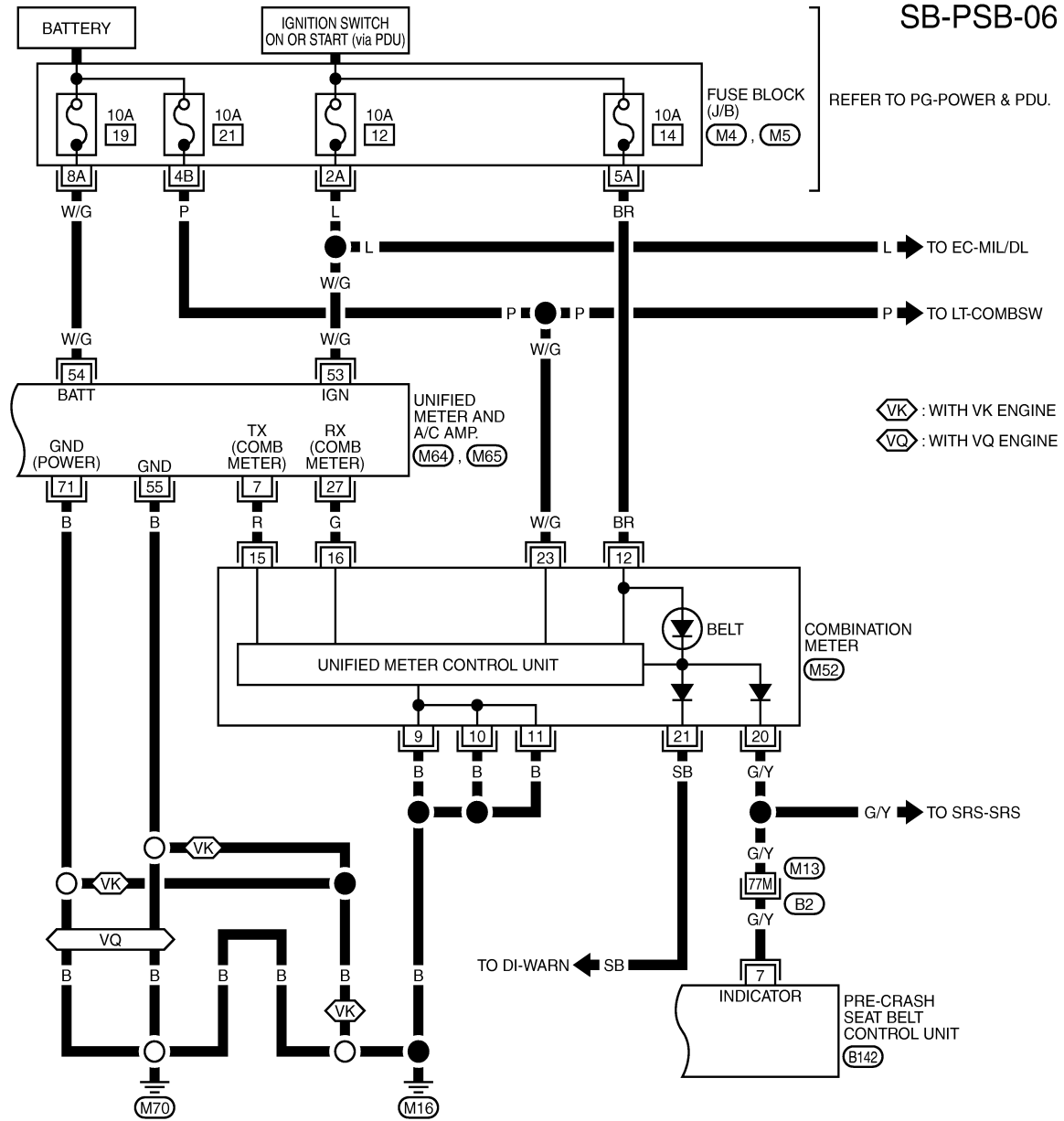

REFER TO THE FOLLOWING.
 (B2) - SUPER MULTIPLE JUNCTION (SMJ)
 (M4), (M5) - FUSE BLOCK - JUNCTION BOX (J/B)

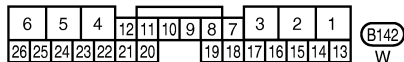
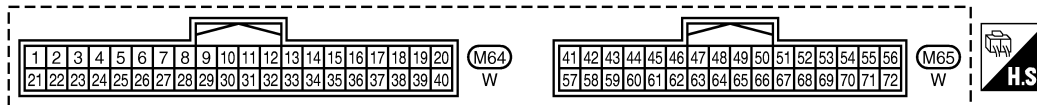

THWT0312E

Terminal and Reference Value for Pre-Crash Seat Belt Control Unit

INFOID:000000002956043

Terminal	Wire Color	Item	Signal Input/Output	Condition	Voltage [V] (Approx.)
1	G/R	Seat belt motor RH release direction signal	Output	Seat belt motor RH operation	Battery voltage
				Other than above	0

PRE-CRASH SEAT BELT

< SERVICE INFORMATION >

Terminal	Wire Color	Item	Signal Input/Output	Condition	Voltage [V] (Approx.)
2	W	Power source (BAT)	Input	—	Battery voltage
3	G/Y	Seat belt motor RH fastened direction signal	Output	Seat belt motor RH operation	Battery voltage
				Other than above	0
4	GY/W	Seat belt motor LH fastened direction signal	Output	Seat belt motor LH operation	Battery voltage
				Other than above	0
5	B/Y	Ground (Driver circuit)	—	—	0
6	L/Y	Seat belt motor LH release direction signal	Output	Seat belt motor LH operation	Battery voltage
				Other than above	0
7	G/Y	Seat belt indicator signal	Output	When driver side seat belt is fastened	Battery voltage
				When driver side seat belt is un-fastened	0
				When driver side seat belt is fastened and system malfunction	Battery voltage ↔ 0
8	LG	Seat belt buckle switch RH	Input	When seat belt is fastened	5
				When seat belt is un-fastened	0
10	SB	Seat belt buckle switch LH	Input	When seat belt is fastened	Battery voltage
				When seat belt is un-fastened	0
13	W/G	Power source (IGN)	Input	Ignition switch ON or START	Battery voltage
16	W	Brake pedal stroke sensor output signal 1	Output	Brake pedal is fully released operation	1
				Brake pedal is slightly depressed operation	4
18	R	Power source (Brake pedal stroke sensor)	Input	—	5
20	G	Brake pedal stroke sensor output signal 2	Output	Brake pedal is fully released operation	4
				Brake pedal is slightly depressed operation	1
21	B	Ground (Brake pedal stroke sensor)	—	—	0
22	P	CAN-L	Input/Output	—	—
24	L	CAN-H	Input/Output	—	—
25	—	Ground (Shield wire)	—	—	0
26	B/Y	Ground (Control circuit)	—	—	0

Work Flow

INFOID:000000002956044

1. Check the symptom and customer's requests.
2. Understand the system description. Refer to [SB-5, "System Description"](#).
3. Perform the preliminary check. Refer to [SB-15, "Preliminary Check"](#).
4. Check the self-diagnosis, results using CONSULT-III. Refer to [SB-14, "CONSULT-III Function \(PRE-CRASH SEATBELT\)"](#).
5. Based on the trouble diagnosis chart, repair or replace the cause of the malfunction. Refer to [SB-15, "Diagnosis Symptom Chart"](#).
6. Does pre-crash seat belt system operate normally?
OK: GO TO 7.
NG: GO TO 4.
7. INSPECTION END

CONSULT-III Function (PRECRASH SEATBELT)

INFOID:000000002956045

CONSULT-III can display each diagnostic item using the diagnostic test modes shown following.

PRE-CRASH SEAT BELT

< SERVICE INFORMATION >

CONSULT-III diagnosis items	Inspection item self-diagnosis mode	Content	Reference page
PRECRASH SEATBELT	SELF-DIAG RESULTS	Carries out the self-diagnosis.	"SELF-DIAGNOSTIC RESULTS ITEM CHART"
	DATA MONITOR	Displays pre-crash seat belt control unit input data in real time.	"DATA MONITOR ITEM CHART"
	CAN DIAG SUPPORT MNTR	The results of transmit / receive diagnosis of CAN communication can be read.	LAN-17. "CAN Diagnostic Support Monitor"
	ECU PART NUMBER	Displays pre-crash seat belt control unit part No.	—

SELF-DIAGNOSTIC RESULTS ITEM CHART

DTC	Self-diagnosis item (CONSULT-III indication)	DTC detection condition	Reference page
U1000	CAN COMM CIRCUIT	When pre-crash seat belt control unit is not transmitting or receiving CAN communication signal for 2 seconds or more.	SB-16
B2451	SB MOTOR RH CIRC	Circuit of seat belt motor (RH) is open or shorted.	SB-24
B2452	SB MOTOR LH CIRC	Circuit of seat belt motor (LH) is open or shorted.	SB-23
B2453	BR STROKE SEN CIRC	Circuit of brake pedal stroke sensor is open or shorted.	SB-21
B2454	MOTOR PWR SUP CIRC	Circuit of motor power supply is open or shorted.	SB-17
B2455	PSB C/U INT CIRC	ECU circuit internal abnormality	—

DATA MONITOR ITEM CHART

Monitor item [OPERATION or UNIT]	Contents	
SB SW RH SIG	"ON/OFF"	RH seat belt switch signal is displayed.
SB SW LH SIG	"ON/OFF"	LH seat belt switch signal is displayed.
VHCL SPEED SE	"Km/h"	Vehicle speed signal is displayed.
B PEDAL SIG1	"V"	Brake pedal stroke sensor 1 signal voltage is displayed.
B PEDAL SIG 2	"V"	Brake pedal stroke sensor 2 signal voltage is displayed.

Preliminary Check

INFOID:000000002956046

PRE-CRASH SEAT BELT OPERATION INSPECTION

WARNING:

- The following tests should be performed in a safe, open place that is free of traffic and obstacles.
- The tests should be performed on a dry, paved road. Do not attempt the tests on wet or unpaved road, open road, or highway. (This may cause an accident or personal injury.)
- Driver and passenger assume it will not operate and prepare themselves accordingly.
 1. Tighten driver and passenger seat belts.
 2. Drive at approximately 25 km/h (16 MPH).
 3. Notify passenger of a sudden stop. Driver and passenger prepare themselves for the possibility of system not operating. Then, driver fully depresses the brake pedal to stop suddenly.
 4. Make sure that the shoulder of the seat belt is pulled while braking.

Diagnosis Symptom Chart

INFOID:000000002956047

Symptom	Diagnosis procedure	Reference page
All functions of pre-crash seat belt system does not operate.	1. Check ignition power supply circuit	SB-16
	2. Check motor power supply and ground circuit [B2454]	SB-17
	3. Check CAN communication circuit	SB-16
	4. Replace pre-crash seat belt control unit	SB-25

PRE-CRASH SEAT BELT

< SERVICE INFORMATION >

Symptom	Diagnosis procedure	Reference page
Driver side pre-crash seat belt system does not operate.	1. Check seat belt buckle switch (driver side) circuit	SB-18
	2. Check pre-crash seat belt motor LH circuit [B2452]	SB-23
	3. Replace pre-crash seat belt control unit	SB-25
Passenger side pre-crash seat belt system does not operate.	1. Check seat belt buckle switch (passenger side) circuit	SB-19
	2. Check pre-crash seat belt motor RH circuit [B2451]	SB-24
	3. Replace pre-crash seat belt control unit	SB-25
Pre-crash seat belt system does not operate during emergency brake operation.	1. Check CAN communication circuit [U1000]	SB-16
	2. Check brake pedal stroke sensor circuit [B2453]	SB-21
	3. Check brake pedal stroke sensor shield wire circuit	SB-25
	4. Replace pre-crash seat belt control unit	SB-25

Check CAN Communication Circuit [U1000]

INFOID:000000002956048

1. CHECK SELF-DIAGNOSTIC RESULT

Ⓟ With CONSULT-III

1. Connect CONSULT-III, and turn ignition switch ON.
2. Touch "PRECRASH SEATBELT" on "SELECT SYSTEM" screen.
3. Touch "SELF-DIAG RESULTS" on "SELECT DIAG MODE" screen.
4. Check display content in self-diagnostic results.

Displayed U1000?

- Yes >> Refer to [LAN-29. "CAN System Specification Chart"](#).
 No >> Inspection END.

Check Ignition Power Supply Circuit

INFOID:000000002956049

1. CHECK FUSE

Check 10A fuse [No.15, located in fuse block (J/B)].

NOTE:

Refer to [SB-5. "Component Parts and Harness Connector Location"](#).

OK or NG

- OK >> GO TO 2.
 NG >> If fuse is blown out, be sure to eliminate cause of malfunction before installing new fuse. Refer to [PG-4](#).

2. CHECK IGNITION POWER SUPPLY CIRCUIT

1. Turn ignition switch OFF.
2. Disconnect pre-crash seat belt control unit connector.
3. Turn ignition switch ON.
4. Check voltage between pre-crash seat belt control unit harness connector and ground.

Terminal		Terminal	Voltage (V) (Approx.)
(+)	(-)		
Pre-crash seat belt control unit connector			
B142	13	Ground	Battery voltage

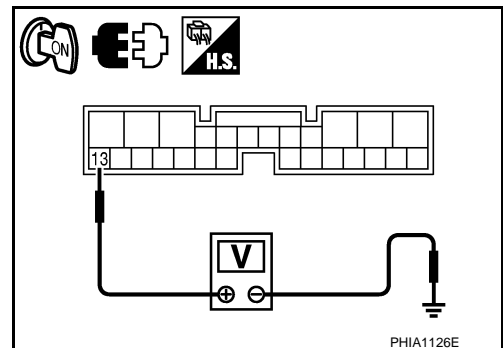

OK or NG

- OK >> Ignition power supply circuit is OK.
 NG >> Check pre-crash seat belt control unit ignition power supply circuit harness.

PRE-CRASH SEAT BELT

< SERVICE INFORMATION >

Check Motor Power Supply and Ground Circuit [B2454]

INFOID:00000002956050

1. CHECK FUSE

Check 30A fusible link (letter **G**, located in the fuse and fusible link box).

NOTE:

Refer to [SB-5. "Component Parts and Harness Connector Location"](#).

OK or NG

OK >> GO TO 2.

NG >> If fuse is blown out, be sure to eliminate cause of malfunction before installing new fuse. Refer to [PG-4](#).

2. CHECK SELF-DIAGNOSTIC RESULT

With CONSULT-III

Select "SELF-DIAG RESULTS" and then make sure the "MOTOR PWR SUP CIRC" is displayed.

CONSULT-III display	CONSULT-III display code
NO DTC	—
MOTOR PWR SUP CIRC	B2454

Without CONSULT-III

When CONSULT-III is not used, omit this inspection, and then GO TO 3.

Displayed B2454?

Yes >> GO TO 3.

No >> Motor power supply system is normal.

3. CHECK MOTOR POWER SUPPLY CIRCUIT

1. Turn ignition switch OFF.
2. Disconnect pre-crash seat belt control unit connector.
3. Check voltage between pre-crash seat belt control unit harness connector and ground.

Terminal		Voltage (V) (Approx.)
(+)	(-)	
Pre-crash seat belt control unit connector	Terminal	
B142	2	Battery voltage

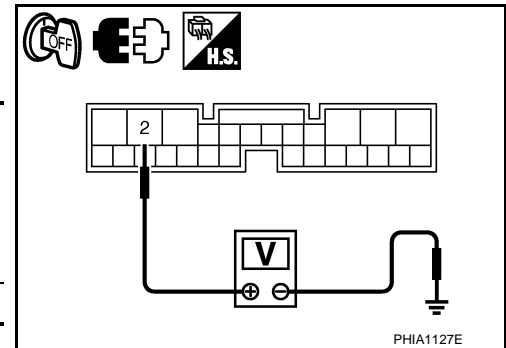

OK or NG

OK >> GO TO 4.

NG >> Repair or replace harness.

4. CHECK PRE-CRASH SEAT BELT CONTROL UNIT GROUND CIRCUIT

1. Disconnect pre-crash seat belt control unit connector.
2. Check continuity between pre-crash seat belt control unit harness connector and ground.

Terminal		Continuity
Pre-crash seat belt control unit connector	Terminal	
B142	5	Yes
	26	

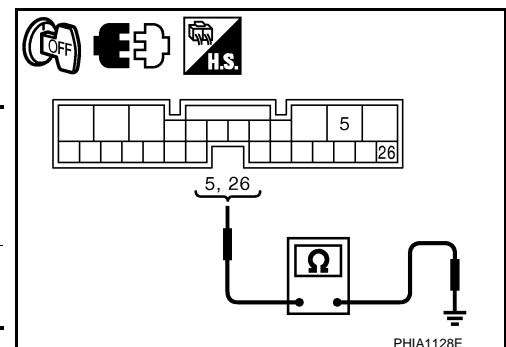

OK or NG

A
B
C
D
E
F
G
I
J
K
L
M
N
O
P

SB

PRE-CRASH SEAT BELT

< SERVICE INFORMATION >

- OK >> Motor power supply and ground circuit is OK.
- NG >> Repair or replace harness.

Check Seat Belt Buckle Switch (Driver Side) Circuit

INFOID:000000002956051

1. CHECK PRE-CRASH SEAT BELT CONTROL UNIT INPUT SIGNAL

Ⓜ With CONSULT-III

Select "SB SW LH SIG" on DATA MONITOR screen, and then make sure that ON/OFF display changes synchronized with the insertion operation to the seat belt buckle.

SB SW LH SIG

- When driver seat belt is not fastened : OFF
- When driver seat belt is fastened : ON

⊗ Without CONSULT-III

1. Turn ignition switch ON.
2. Check voltage between seat belt buckle switch (driver side) harness connector and ground.

Terminal		Condition	Voltage (V) (Approx.)
(+)	(-)		
Seat belt buckle switch connector (driver side)	Terminal		
B203	1	When seat belt is unfastened	0
		When seat belt is fastened	Battery voltage

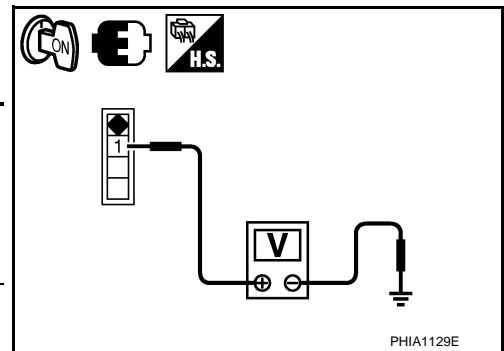

OK or NG

- OK >> Seat belt buckle switch (driver side) circuit is OK.
- NG >> GO TO 2.

2. CHECK SEAT BELT BUCKLE SWITCH (DRIVER SIDE) HARNESS

1. Turn ignition switch OFF.
2. Disconnect pre-crash seat belt control unit and seat belt buckle switch (driver side) connector.
3. Check continuity between pre-crash seat belt control unit harness connector and seat belt buckle switch (driver side) harness connector.

A		B		Continuity
Pre-crash seat belt control unit connector	Terminal	Seat belt buckle switch (driver side) connector	Terminal	
B142	10	B203	1	Yes

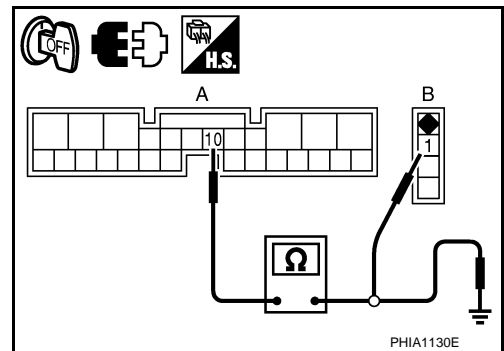

4. Check continuity between pre-crash seat belt control unit harness connector and ground.

A		Ground	Continuity
Pre-crash seat belt control unit connector	Terminal		
B142	10		No

OK or NG

- OK >> GO TO 3.
- NG >> Repair or replace harness.

PRE-CRASH SEAT BELT

< SERVICE INFORMATION >

3. CHECK LH SEAT BELT SWITCH

Check continuity between seat belt buckle switch (driver side) while performing the insertion operation to the seat belt buckle.

Seat belt buckle switch connector (driver side)	Terminal		Condition	Continuity
	1	2		
B203	1	2	When seat belt is unfastened	Yes
			When seat belt is fastened	No

OK or NG

OK >> GO TO 4.

NG >> Replace seat belt buckle switch (driver side).

4. CHECK LH SEAT BELT SWITCH GROUND CIRCUIT HARNNES

Check continuity between seat belt buckle switch (driver side) harness connector and ground.

Seat belt buckle switch connector (driver side)	Terminal		Continuity
	Terminal	Ground	
B203	2	Ground	Yes

OK or NG

OK >> Check harness connection.

- If it is OK, replace pre-crash seat belt control unit.
- If it is NG, repair or replace malfunction part.

NG >> Repair or replace harness.

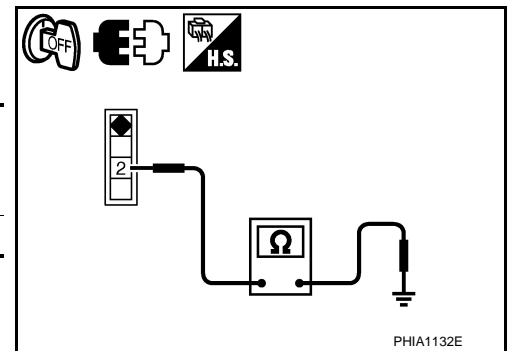
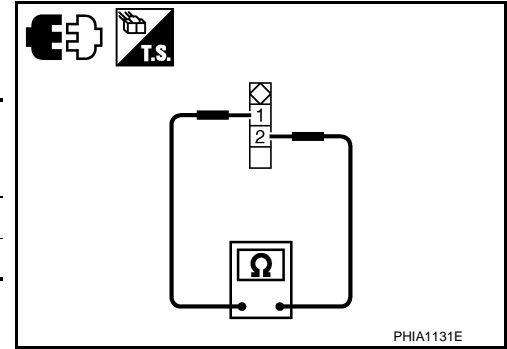

Check Seat Belt Buckle Switch (Passenger Side) Circuit

INFOID:0000000002956052

1. CHECK PRE-CRASH SEAT BELT CONTROL UNIT INPUT SIGNAL

With CONSULT-III

Select "SB SW RH SIG" on DATA MONITOR screen, and then make sure that ON/OFF display changes synchronized with the insertion operation to the seat belt buckle.

SB SW RH SIG

When passenger seat belt is not fastened :OFF

When passenger seat belt is fastened :ON

Without CONSULT-III

1. Turn ignition switch ON.
2. Check voltage between seat belt buckle switch (passenger side) harness connector and ground.

Seat belt buckle switch connector (passenger side)	Terminal		Condition	Voltage (V) (Approx.)
	(+)	(-)		
B253	1	Ground	When seat belt is unfastened	0
			When seat belt is fastened	5

OK or NG

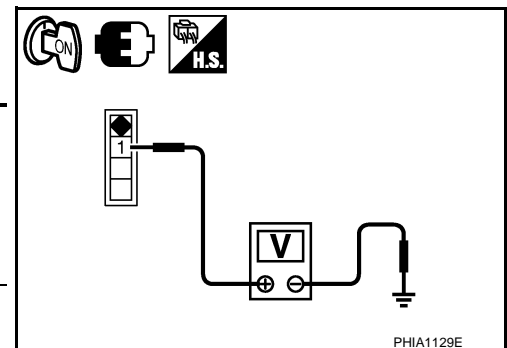

PRE-CRASH SEAT BELT

< SERVICE INFORMATION >

- OK >> Seat belt buckle switch (passenger side) circuit is OK.
- NG >> GO TO 2.

2. CHECK SEAT BELT BUCKLE SWITCH (PASSENGER SIDE) HARNESS

1. Turn ignition switch OFF.
2. Disconnect pre-crash seat belt control unit and seat belt buckle switch (passenger side) connector.
3. Check continuity between pre-crash seat belt control unit harness connector and seat belt buckle switch (passenger side) harness connector.

A		B		Continuity
Pre-crash seat belt control unit connector	Terminal	Seat belt buckle switch (passenger side) connector	Terminal	
B142	8	B253	1	Yes

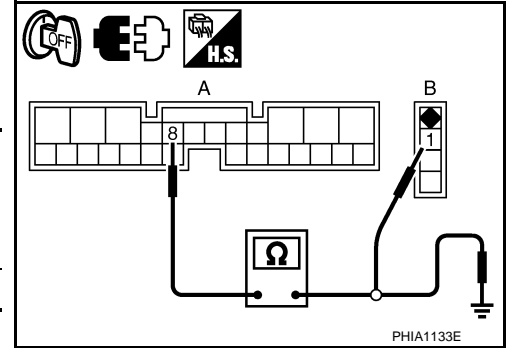

4. Check continuity between pre-crash seat belt control unit harness connector and ground.

A		Ground	Continuity
Pre-crash seat belt control unit connector	Terminal		
B142	8		No

OK or NG

- OK >> GO TO 3.
- NG >> Repair or replace harness.

3. CHECK RH SEAT BELT SWITCH

Check continuity between seat belt buckle switch (passenger side) while performing the insertion operation to the seat belt buckle.

Seat belt buckle switch connector (passenger side)	Terminal		Condition	Continuity
	1	2		
B253	1	2	When seat belt is unfastened	Yes
			When seat belt is fastened	No

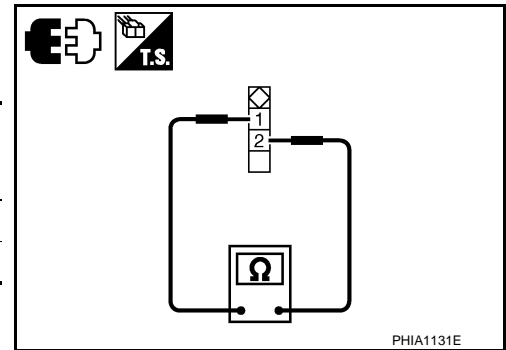

OK or NG

- OK >> GO TO 4.
- NG >> Replace seat belt buckle (passenger side).

4. CHECK RH SEAT BELT SWITCH GROUND CIRCUIT HARNNES

Check continuity between seat belt buckle switch (passenger side) harness connector and ground.

Terminal		Ground	Continuity
Seat belt buckle switch connector (passenger side)	Terminal		
B253	2		Yes

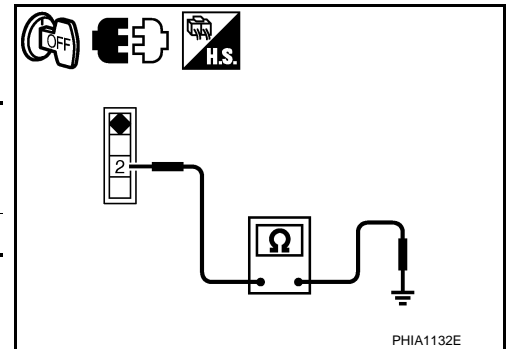

OK or NG

- OK >> Check harness connection.
 - If it is OK, replace pre-crash seat belt control unit.
 - If it is NG, repair or replace malfunction part.
- NG >> Repair or replace harness.

PRE-CRASH SEAT BELT

< SERVICE INFORMATION >

Check Brake Pedal Stroke Sensor Circuit [B2453]

INFOID:00000002956053

1. CHECK SELF-DIAGNOSTIC RESULT

With CONSULT-III

Select "SELF-DIAG RESULTS", and then make sure that "BR STROKE SEN CIRC" is displayed.

CONSULT-III display	CONSULT-III display code
NO DTC	—
BR STROKE SEN CIRC	B2453

Without CONSULT-III

When CONSULT-III is not used, omit this inspection, and then GO TO 2.

Displayed B2453?

- Yes >> GO TO 3.
No >> GO TO 2.

2. CHECK PRE-CRASH SEAT BELT CONTROL UNIT INPUT SIGNAL

With CONSULT-III

Select "B PEDAL SIG1" and "B PEDAL SIG2", and then make sure that the voltage changes synchronized with brake pedal operation.

B PEDAL SIG1

Brake released → depressed : Approx. 1 → 4V

B PEDAL SIG 2

Brake released → depressed : Approx. 4 → 1V

Without CONSULT-III

- Turn ignition switch ON.
- Check voltage between pre-crash seat belt control unit harness connector and ground.

Terminal (+)		Terminal (-)	Condition	Voltage (V) (Approx.)
Pre-crash seat belt control unit connector	Terminal			
B142	16	Ground	Brake released → depressed	1 → 4
	20			4 → 1

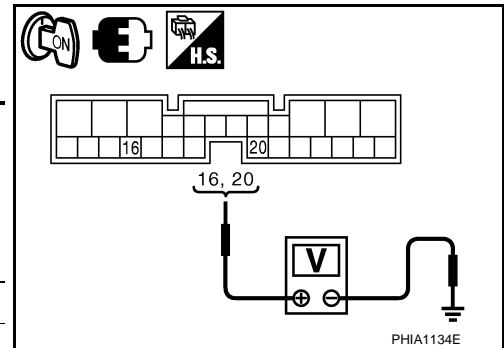

OK or NG

- OK >> Brake pedal stroke sensor system is normal.
NG >> GO TO 3.

3. CHECK BRAKE PEDAL STROKE SENSOR HARNESS

- Turn ignition switch OFF.
- Disconnect pre-crash seat belt control unit connector and brake pedal stroke sensor connector.

PRE-CRASH SEAT BELT

< SERVICE INFORMATION >

- Check continuity between pre-crash seat belt control unit harness connector and brake pedal stroke sensor harness connector.

A		B		Continuity
Pre-crash seat belt control unit connector	Terminal	Brake pedal stroke sensor connector	Terminal	
B142	16	E125	1	Yes
	18		2	
	20		3	
	21		4	

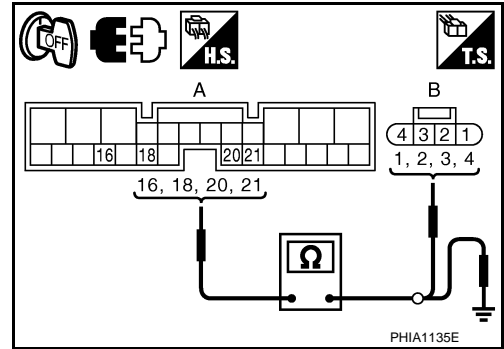

- Check continuity between pre-crash seat belt control unit harness connector and ground.

A		Ground	Continuity
Pre-crash seat belt control unit connector	Terminal		
B142	16	Ground	No
	18		
	20		
	21		

OK or NG

- OK >> GO TO 4.
- NG >> Repair or replace harness between pre-crash seat belt control unit and brake pedal stroke sensor.

4. CHECK BRAKE PEDAL STROKE SENSOR POWER SUPPLY

- Connect pre-crash seat belt control unit connector.
- Turn ignition switch ON.
- Check voltage between pre-crash seat belt control unit harness connector and ground.

Terminal (+)		Terminal (-)	Voltage (V) (Approx.)
Pre-crash seat belt control unit connector	Terminal		
B142	18	Ground	5

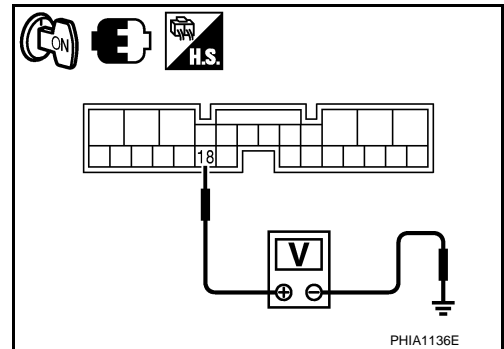

OK or NG

- OK >> GO TO 5.
- NG >> Replace pre-crash seat belt control unit.

5. CHECK BRAKE PEDAL STROKE SENSOR

Check continuity between brake pedal stroke sensor while performing brake operation.

Brake pedal stroke sensor connector	Terminal	Condition	Resistance (K Ω) (Approx.)
E125	2	Brake released \rightarrow depressed	1.0 \rightarrow 0.2
			0.2 \rightarrow 1.0

OK or NG

- OK >> Check harness connection.

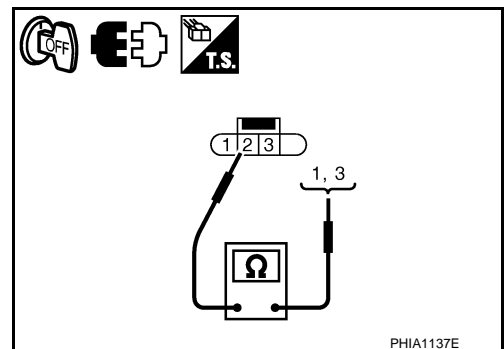

PRE-CRASH SEAT BELT

< SERVICE INFORMATION >

- If it is OK, replace pre-crash seat belt control unit.
- If it is NG, repair or replace malfunction part.

NG >> Replace brake pedal stroke sensor.

Check Pre-Crash Seat Belt Motor LH Circuit [B2452]

INFOID:000000002956054

1. CHECK SELF-DIAGNOSTIC RESULT

With CONSULT-III

Select "SELF-DIAG RESULTS" of CONSULT-III, and then make sure that "SB MOTOR LH CIRC" is displayed.

CONSULT-III display	CONSULT-III display code
NO DTC	—
SB MOTOR LH CIRC	B2452

Without CONSULT-III

When CONSULT-III is not used, omit this inspection, and then GO TO 2.

Displayed B2452?

Yes >> GO TO 2.

No >> Pre-crash seat belt motor LH circuit is OK.

2. CHECK SEAT BELT MOTOR LH HARNESS

1. Turn ignition switch OFF.
2. Disconnect pre-crash seat belt control unit connector and pre-crash seat belt motor LH connector.
3. Check continuity between pre-crash seat belt control unit harness connector and pre-crash seat belt motor LH harness connector.

A		B		Continuity
Pre-crash seat belt control unit connector	Terminal	Pre-crash seat belt motor LH connector	Terminal	
B142	4	B32	1	Yes
	6		2	

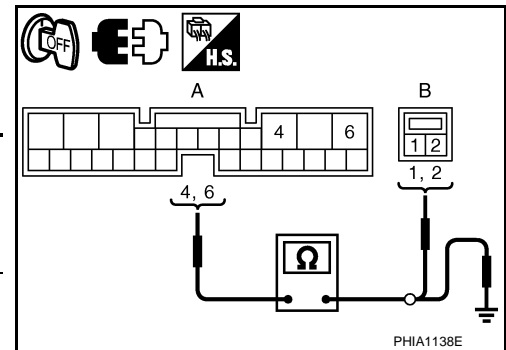

4. Check continuity between pre-crash seat belt control unit harness connector and ground.

A		Ground	Continuity
Pre-crash seat belt control unit connector	Terminal		
B142	4		No
	6		

OK or NG

OK >> GO TO 3.

NG >> Repair or replace harness.

3. CHECK SEAT BELT MOTOR LH

PRE-CRASH SEAT BELT

< SERVICE INFORMATION >

Check continuity between pre-crash seat belt motor LH.

Pre-crash seat belt motor LH connector	Terminal		Continuity
	1	2	
B32	1	2	Yes

OK or NG

- OK >> Replace pre-crash seat belt control unit.
- NG >> Replace pre-crash seat belt motor LH.

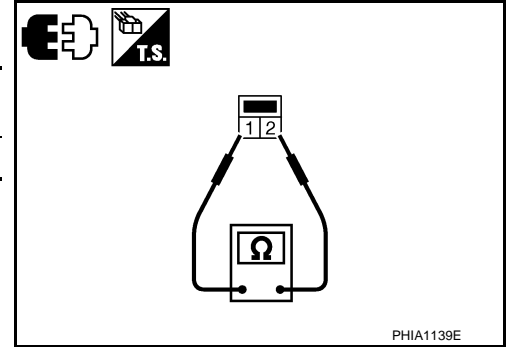

Check Pre-Crash Seat Belt Motor RH Circuit [B2451]

INFOID:000000002956055

1. CHECK SELF-DIAGNOSTIC RESULT

Ⓟ With CONSULT-III

Select "SELF-DIAG RESULTS" of CONSULT-III, and then make sure that "SB MOTOR RH CIRC" is displayed.

CONSULT-III display	CONSULT-III display code
NO DTC	—
SB MOTOR RH CIRC	B2451

ⓧ Without CONSULT-III

When CONSULT-III is not used, omit this inspection, and then GO TO 2.

Displayed B2451?

- Yes >> GO TO 2.
- No >> Pre-crash seat belt motor RH circuit is OK.

2. CHECK SEAT BELT MOTOR RH HARNESS

1. Turn ignition switch OFF.
2. Disconnect pre-crash seat belt control unit connector and pre-crash seat belt motor RH connector.
3. Check continuity between pre-crash seat belt control unit harness connector and pre-crash seat belt motor RH harness connector.

A		B		Continuity
Pre-crash seat belt control unit connector	Terminal	Pre-crash seat belt motor RH connector	Terminal	
B142	1	B422	2	Yes
	3		1	

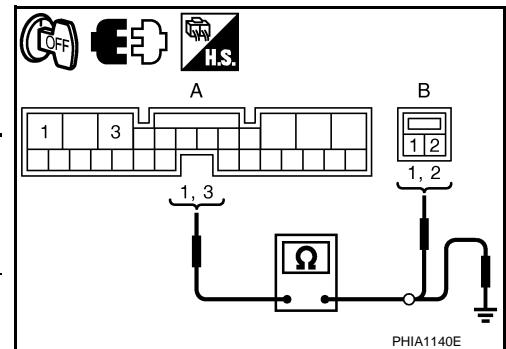

4. Check continuity between pre-crash seat belt control unit harness connector and ground.

A		Ground	Continuity
Pre-crash seat belt control unit connector	Terminal		
B142	1		No
	3		

OK or NG

- OK >> GO TO 3.
- NG >> Repair or replace harness.

3. CHECK SEAT BELT MOTOR RH

PRE-CRASH SEAT BELT

< SERVICE INFORMATION >

Check continuity between pre-crash seat belt motor RH.

Pre-crash seat belt motor RH connector	Terminal		Continuity
	1	2	
B422	1	2	Yes

OK or NG

- OK >> Replace pre-crash seat belt control unit.
- NG >> Replace pre-crash seat belt motor RH.

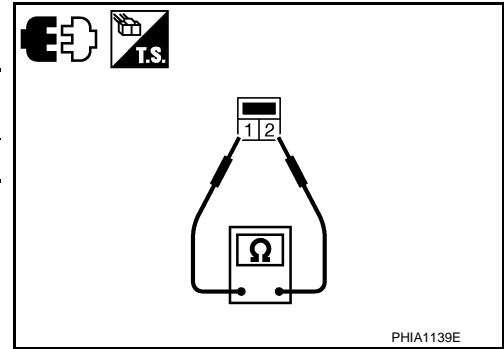

Check Brake Pedal Stroke Sensor Shield Wire Circuit

INFOID:000000002956056

1. CHECK PRE-CRASH SEAT BELT INPUT SIGNAL

With CONSULT-III

Select "B PEDAL SIG1 and 2" on DATA MONITOR screen, and then make sure that the voltage does not change if brake pedal is not operated.

NOTE:

Diagnosis should be performed with engine running, audio and air conditioner operating.

B PEDAL SIG1

Brake released :There is no change in the voltage value, and it is almost constant

B PEDAL SIG2

Brake released :There is no change in the voltage value, and it is almost constant.

Without CONSULT-III

1. Start engine.
2. Check voltage between pre-crash seat belt harness connector.

Terminal (+)		Terminal (-)	Condition	Voltage (V) (Approx.)
Pre-crash seat belt control unit connector	Terminal			
B142	16	Ground	Performed with engine running, audio and air conditioner operating and brake pedal released.	There is no change in the voltage value, and it is almost constant
	20			

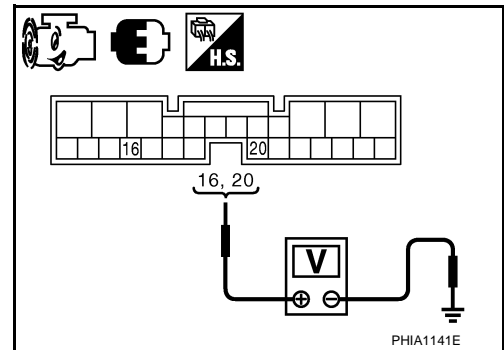

OK or NG

- OK >> Brake pedal stroke sensor shield wire circuit is OK.
- NG >> Check shield wire for damage. Repair or replace if necessary.

Removal and Installation of Pre-Crash Seat Belt Control Unit

INFOID:000000002956057

REMOVAL

1. Remove trunk side finisher LH. Refer to [EI-65. "Component Parts Location"](#).

PRE-CRASH SEAT BELT

< SERVICE INFORMATION >

2. Remove pre-crash seat belt control unit mounting bolts.
3. Remove pre-crash seat belt control unit connector, and the pre-crash seat belt control unit.

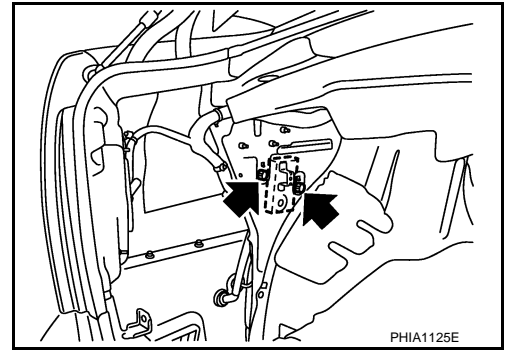

INSTALLATION

Install in the reverse order of removal.

SEAT BELTS

< SERVICE INFORMATION >

SEAT BELTS

System Description

INFOID:000000002956058

SEAT BELT WARNING CHIME

- With ignition switch turned ON and seat belt unfastened (seat belt switch ON), warning chime will sound for approximately 6 seconds.
- If warning chime does not sound, refer to [DI-66. "Seat Belt Buckle Switch Signal Inspection"](#).

SEAT BELT WARNING LAMP

- Fasten driver's seat belt.
- The seat belt warning lamp should go out.
- If the seat belt warning lamp does not go out, refer to [DI-37. "Wiring Diagram - WARN -"](#).

Removal and Installation of Front Seat Belt

INFOID:000000002956059

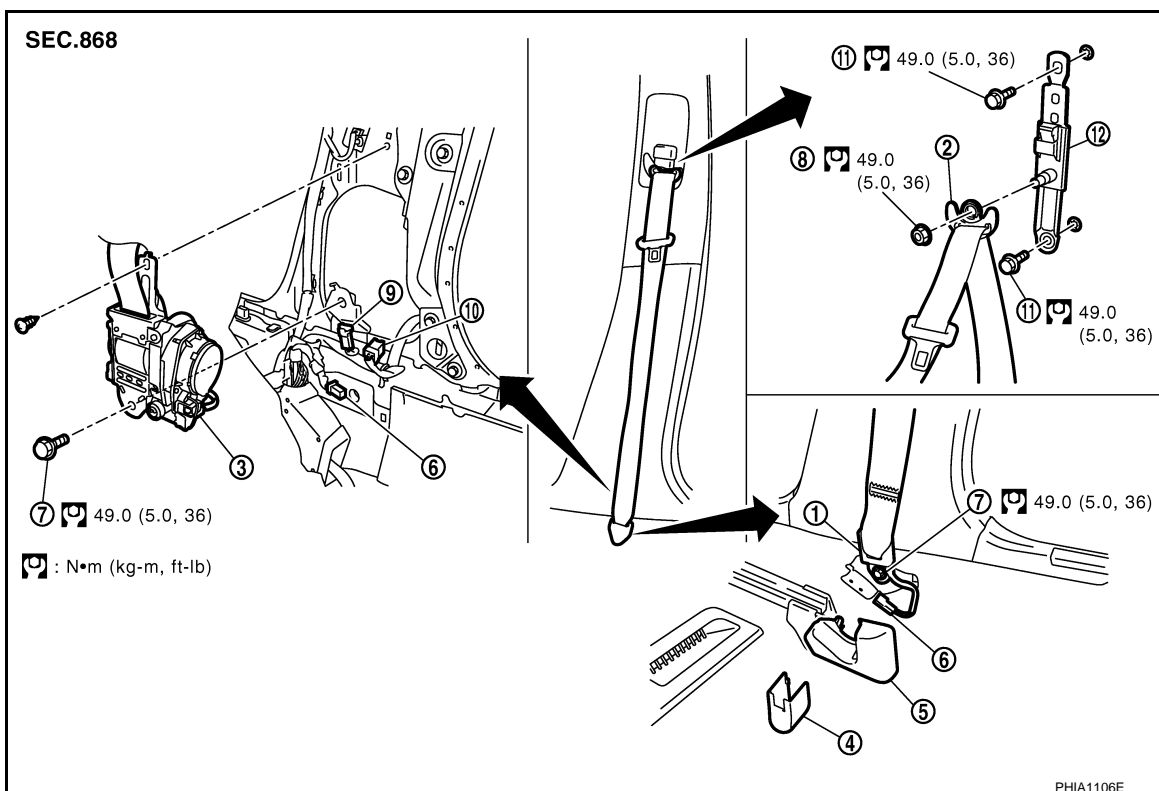

- | | | |
|--|--|--|
| 1. Outer anchor | 2. Shoulder anchor | 3. Pre-tensioner seat belt retractor |
| 4. Belt tension sensor cover (passenger side only) | 5. Cover protector (passenger side only) | 6. Belt tension sensor connector (passenger side only) |
| 7. Anchor bolt | 8. Anchor nut | 9. Seat belt pre-tensioner connector |
| 10. Pre-crash seat belt connector | 11. Bolt | 12. Seat belt adjuster |

CAUTION:

Before servicing SRS, turn the ignition switch off, disconnect both battery cables and wait at least 3 minutes.

REMOVAL OF SEAT BELT RETRACTOR

1. Remove the outer anchor.
 - Remove the belt tension sensor cover and cover protector (passenger side only).
 - Disconnect the belt tension sensor connector (passenger side only).
 - Remove the fixing bolt of the outer anchor.

SEAT BELTS

< SERVICE INFORMATION >

2. Remove the shoulder anchor.
 - Remove the center pillar lower and upper garnishes, refer to [EI-48](#).
 - Remove the fixing anchor nut of the shoulder anchor.
3. Remove the seat belt assembly.
 - Disconnect the seat belt pre-tensioner connector.

CAUTION:

- **For installing/removing seat belt pre-tensioner connector, insert thin screwdriver wrapped in tape into notch, lift lock and remove connector.**
- **Install connector with lock raised, and push lock into connector.**

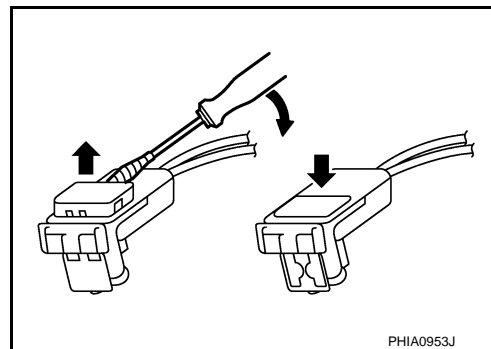

- Disconnect the pre-crash seat belt connector (for only the vehicle with pre-clash seat belt).
- Remove the fixing screw and anchor bolt of the pre-tensioner seat belt retractor.

INSTALLATION OF SEAT BELT RETRACTOR

- Install in the reverse order of removal.
- Tighten by specified torque.

Tightening torque : 49.0 N-m (5.0 kg-m, 36 ft-lb)

REMOVAL OF SEAT BELT BUCKLE

Remove the seat belt buckle.

- Remove the front seat from vehicle, refer to [SE-146, "Removal and Installation"](#) (For ease of tool operation in narrow space).
- Disconnect the seat belt buckle harness connector.
- Remove the fixing anchor bolt of the seat belt buckle.

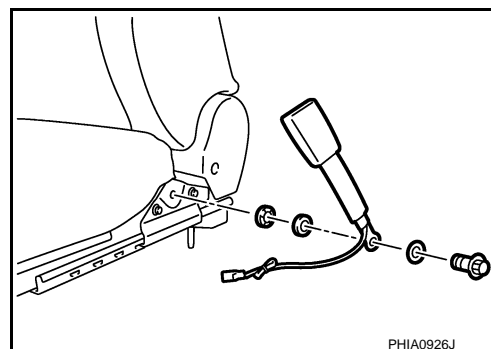

INSTALLATION OF SEAT BELT BUCKLE

- Install in the reverse order of removal.
- Tighten by specified torque.

Tightening torque : 49.0 N-m (5.0 kg-m, 36 ft-lb)

SEAT BELTS

< SERVICE INFORMATION >

Removal and Installation of Rear Seat Belt

INFOID:00000002956060

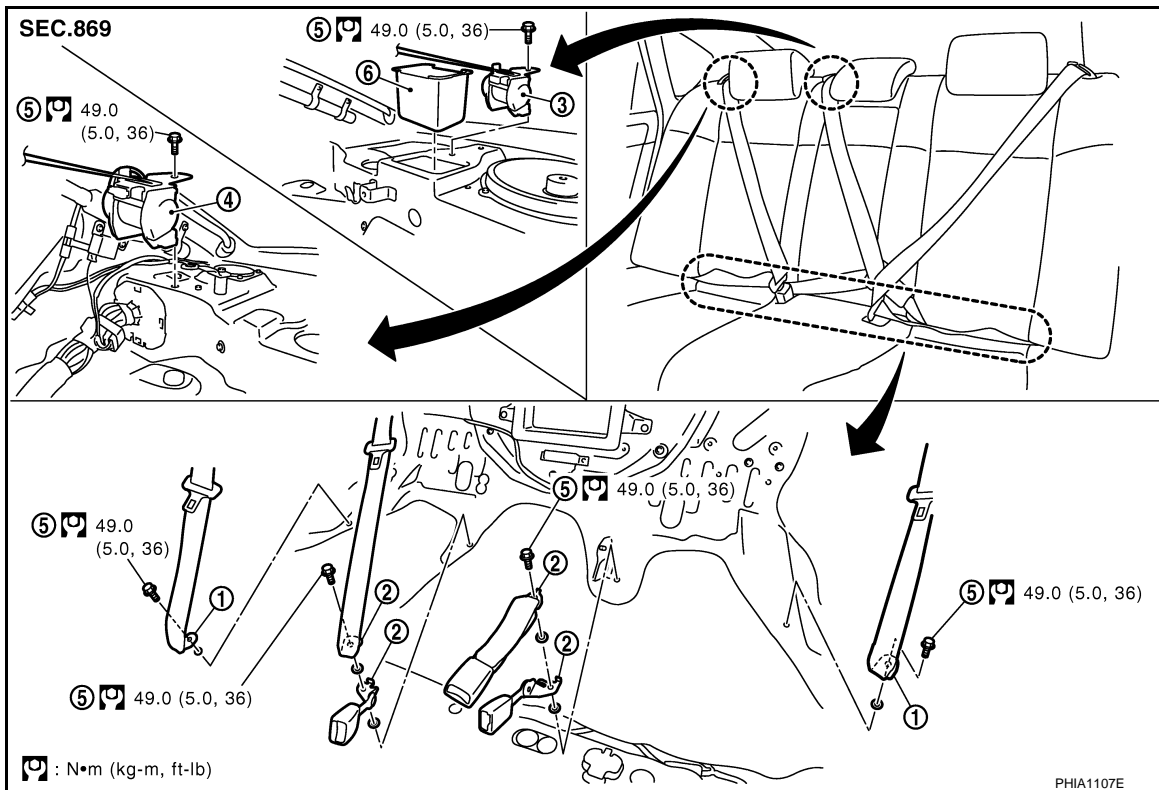

- | | | |
|------------------------------|-----------------|-------------------------------|
| 1. Outer anchor | 2. Inner anchor | 3. Center seat belt retractor |
| 4. Outer seat belt retractor | 5. Anchor bolt | 6. Retractor cover |

Refer to [GI-9. "Component"](#) for symbols in the figure.

REMOVAL OF SEAT BELT RETRACTOR

1. Remove the outer and inner anchors.
 - Remove the rear seat cushion, refer to [SE-154. "Removal and Installation"](#).
 - Remove the outer anchor fixing anchor bolt and the anchor bolt tightening the inner anchor together with the seat belt buckle.
2. Remove the seat belt assembly.
 - Remove the rear seatback, refer to [SE-154. "Removal and Installation"](#).
 - Remove the rear kicking plate, the rear wheelhouse garnish and the rear pillar finisher, refer to [EI-48](#).
 - Remove the seat belt finisher from the rear parcel shelf finisher, refer to [EI-52](#).
 - Remove the rear parcel shelf finisher, refer to [EI-52](#).
 - Remove the fixing anchor bolt of the seat belt retractor.

INSTALLATION OF SEAT BELT RETRACTOR

- Install in the reverse order of removal.
- Tighten by specified torque.

Tightening torque : 49.0 N·m (5.0 kg-m, 36 ft-lb)

REMOVAL OF SEAT BELT BUCKLE

Remove the seat belt buckle.

- Remove the rear seat cushion, refer to [SE-154. "Removal and Installation"](#).
- Remove the fixing anchor bolt of the inner anchor.

INSTALLATION OF SEAT BELT BUCKLE

- Install in the reverse order of removal.
- Tighten by specified torque.

A
B
C
D
E
F
G
SB
I
J
K
L
M
N
O
P

SEAT BELTS

< SERVICE INFORMATION >

Tightening torque : 49.0 N-m (5.0 kg-m, 36 ft-lb)

Seat Belt Inspection

INFOID:000000002956061

AFTER A COLLISION

WARNING:

Inspect all seat belt assemblies including retractors and attaching hardware after any collision. NISSAN / INFINITI recommends that all seat belt assemblies in use during a collision be replaced unless the collision was minor and the belts show no damage and continue to operate properly. Failure to do so could result in serious personal injury in an accident. Seat belt assemblies not in use during a collision should also be replaced if either damage or improper operation is noted. Seat belt pre-tensioned should be replaced even if the seat belts are not in use during a frontal collision in which the air bags are deployed.

Replace any seat belt assembly (including anchor bolts) if:

- The seat belt was in use at the time of a collision (except for minor collisions and the belts, retractors and buckles show no damage and continue to operate properly).
- The seat belt was damaged in an accident. (i.e. torn webbing, bent retractor or guide, etc.)
- The seat belt attaching point was damaged in an accident. Inspect the seat belt attaching area for damage or distortion and repair as necessary before installing a new seat belt assembly.
- Anchor bolts are deformed or worn out.
- The seat belt pre-tensioner should be replaced even if the seat belts are not in use during the collision in which the air bags are deployed.

PRELIMINARY CHECKS

1. Check the seat belt warning lamp/chime for proper operation as follows:
 - a. Switch ignition ON. The seat belt warning lamp should illuminate. Also, the seat belt warning chime should sound for about six seconds.
 - b. Fasten driver's seat belt. The seat belt warning lamp should go out and the chime (if sounding) should stop.
2. If the air bag warning lamp is blinking, conduct self-diagnosis using CONSULT-III, and air bag warning lamp. Refer to [SRS-22. "SRS Operation Check \(USER MODE\)".](#)
3. Check that the seat belt retractor, seat belt anchor and buckle bolts are securely attached.
4. Check the shoulder seat belt guide and shoulder belt height adjuster for front seats. Ensure guide swivels freely and that webbing lays flat and does not bind in guide. Ensure height adjuster operates properly and holds securely.
5. Check retractor operation:
 - a. Fully extend the seat belt webbing and check for twists, tears or other damage.
 - b. Allow the seat belt to retract. Ensure that webbing returns smoothly and completely into the retractor. If the seat belt does not return smoothly, wipe the inside of the loops with a clean paper cloth. Because dirt built up in the loops of the upper anchors can cause the seat belts to retract slowly.
 - c. Fasten the seat belt. Check the seat belt returns smoothly and completely to the retractor. If the webbing does not return smoothly, the cause may be an accumulation of dust or dirt. Use the "SEAT BELT TAPE SET" and perform the following steps.

Inspect the front seat belt though-anchor

1. Pull the seat belt out to a length of 500 mm (19.69 in) or more.
 2. Use a clip or other device to fix the seat belt at the center pillar webbing opening.
 3. Pass a thin wire through the though-anchor webbing opening. Hold both ends of the wire and pull it tautly while moving it up and down several times along the webbing opening surface to move matter stuck there.
 4. Any dirt that can not be removed with the wire can be removed by cleaning the opening with a clean cloth.
 5. Apply tape at the point where the webbing contacts the though-anchor webbing opening.
- NOTE:**
Apply the tape so that there is no looseness or wrinkling.
6. Remove the clip fixing the seat belt and check that the webbing returns smoothly.
 6. Repeat steps above as necessary to check the other seat belts.

SEAT BELTS

< SERVICE INFORMATION >

SEAT BELT RETRACTOR ON-VEHICLE CHECK

Emergency Locking Retractors (ELR) and Automatic Locking Retractors (ALR)

NOTE:

All seat belt retractors are of the Emergency Locking Retractors (ELR) type. In an emergency (sudden stop) the retractor will lock and prevent the webbing from extending any further. All 3-point type seat belt retractors except the driver's seat belt also have an Automatic Locking Retractors (ALR) mode. The ALR mode (also called child restraint mode) is used when installing child seats. The ALR mode is activated when the seat belt is fully extended. When the webbing is then retracted partially, the ALR mode automatically locks the seat belt in a specific position so the webbing cannot be extended any further. To cancel the ALR mode, allow the seat belt to fully wind back into the retractor.

Check the seat belt retractors using the following test(s) to determine if a retractor assembly is operating properly.

ELR Function Stationary Check

Grasp the shoulder webbing and pull forward quickly. The retractor should lock and prevent the belt from extending further.

ALR Function Stationary Check

1. Pull out entire length of seat belt from retractor until a click is heard.
2. Retract the webbing partially. A clicking noise should be heard as the webbing retracts indicating that the retractor is in the Automatic Locking Retractors (ALR) mode.
3. Grasp the seat belt and try to pull out the retractor. The webbing must lock and not extend any further. If NG, replace the retractor assembly.
4. Allow the entire length of the webbing to retract to cancel the automatic locking mode.

ELR Function Moving Check

WARNING:

Perform the following test in a safe, open area clear of other vehicles and obstructions (for example, a large, empty parking lot). Road surface must be paved and dry. DO NOT perform the following test on wet or gravel roads or on public streets and highways. This could result in an accident and serious personal injury. The driver and passenger must be prepared to brace themselves in the event the retractor does not lock.

1. Fasten driver's seat belt. Buckle a passenger into the seat for the belt that is to be tested.
2. Proceed to the designated safe area.
3. Drive the vehicle at approximately 16 km/h (10 MPH). Notify any passengers of a pending sudden stop and the driver and passenger must be prepared to brace themselves in the event the retractor does not lock, apply brakes firmly and make a very hard stop.

During stop, seat belts should lock and not be extended. If the seat belt retractor assembly does not lock, perform the retractor off-vehicle check.

SEAT BELT RETRACTOR OFF-VEHICLE CHECK (FRONT SEAT BELT)

1. Remove the seat belt retractor.
Remove the front seat belt assembly, refer to [SB-27. "Removal and Installation of Front Seat Belt"](#).
2. Slowly pull out webbing while tilting the retractor assembly forward from the mounted position without twisting the retractor assembly as shown in the illustration.

A : The webbing can be pulled out in case the retractor is tilted 15° degree or less.

B : The webbing can't be pulled out in case the retractor is tilted 35° degree or more.

- A and B show tilting angles.
- ↖ : Vehicle front.

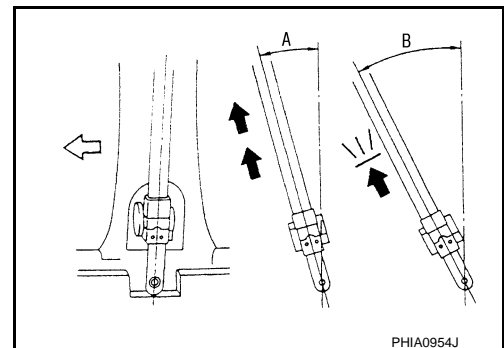

Replace the seat belt assembly if it does not operate normally.

SEAT BELTS

< SERVICE INFORMATION >

SEAT BELT RETRACTOR OFF-VEHICLE CHECK (REAR SEAT BELT)

1. Remove the seat belt retractor.
Remove the front seat belt assembly, refer to [SB-29, "Removal and Installation of Rear Seat Belt"](#).
2. Slowly pull out webbing while tilting the retractor assembly forward from the mounted position without twisting the retractor assembly as shown in the illustration.
A : The webbing can be pulled out in case the retractor is tilted 15° degree or less.
B : The webbing can't be pulled out in case the retractor is tilted 35° degree or more.
 - A and B show tilting angles.
 - ⇐ : Vehicle front.

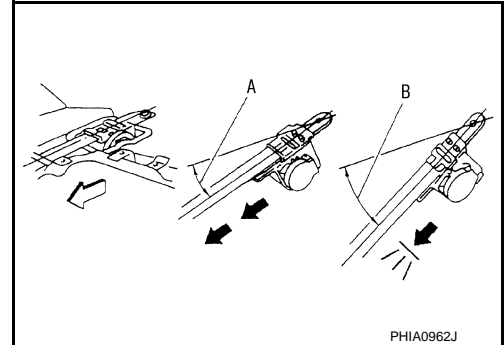

Replace the seat belt assembly if it does not operate normally.

LATCH (LOWER ANCHORS AND TETHER FOR CHILDREN) SYSTEM

< SERVICE INFORMATION >

LATCH (LOWER ANCHORS AND TETHER FOR CHILDREN) SYSTEM

Removal and Installation

INFOID:000000002956062

CAUTION:

Replace anchor bolts if they are deformed or worn out.

REMOVAL

1. Remove the rear seat. Refer to [SE-154, "Removal and Installation"](#).
2. Remove rear seat frame (Models with rear power seat).
3. Remove LATCH (Lower Anchor and Tether for Children) system.

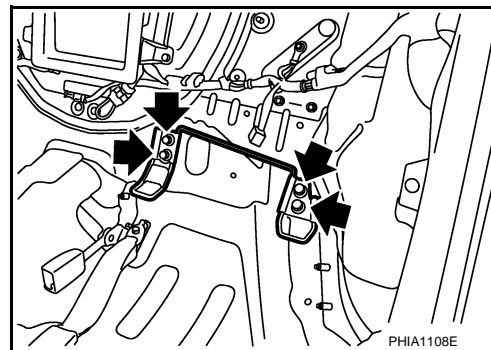

INSTALLATION

- Install in the reverse order of removal.
- Tighten by specified torque.

Tightening torque : 28.0 N-m (2.9 kg-m, 21 ft-lb)

A
B
C
D
E
F
G
I
J
K
L
M
N
O
P

SB

TOP TETHER STRAP CHILD RESTRAINT

< SERVICE INFORMATION >

TOP TETHER STRAP CHILD RESTRAINT

Removal and Installation

INFOID:000000002956063

CAUTION:

Replace anchor bolts if they are deformed or worn out.

REMOVAL

1. Remove the top tether strap child restraint cover. Refer to [EI-52, "Component Parts Location"](#).
2. Remove the top tether strap child restraint.

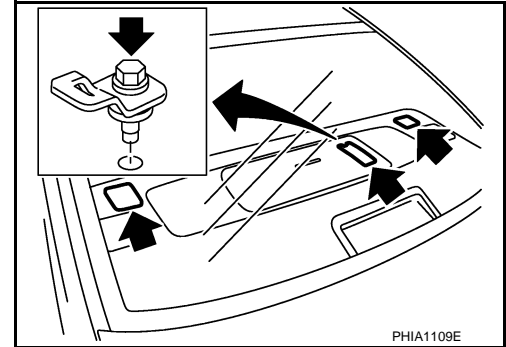

INSTALLATION

- Install in the reverse order of removal.
- Tighten by specified torque.

Tightening torque : 30.0 N-m (3.1 kg-m, 22 ft-lb)