

SECTION **BR**  
BRAKE SYSTEM

A  
B  
C  
D  
E

CONTENTS

<b>PRECAUTION</b> .....	3	<b>DISC ROTOR</b> .....	14	<b>BR</b>
		DISC ROTOR : Inspection and Adjustment .....	14	
<b>PRECAUTIONS</b> .....	3	<b>REAR DISC BRAKE</b> .....	16	<b>G</b>
Precaution for Supplemental Restraint System (SRS) "AIR BAG" and "SEAT BELT PRE-TENSIONER" .....	3	<b>BRAKE PAD</b> .....	16	
Precaution Necessary for Steering Wheel Rotation after Battery Disconnect .....	3	BRAKE PAD : Inspection and Adjustment .....	16	<b>H</b>
Precaution for Procedure without Cowl Top Cover.....	4	<b>DISC ROTOR</b> .....	16	
Precaution for Brake System .....	4	DISC ROTOR : Inspection and Adjustment .....	16	<b>I</b>
<b>PREPARATION</b> .....	5	<b>REMOVAL AND INSTALLATION</b> .....	18	
<b>PREPARATION</b> .....	5	<b>BRAKE PEDAL</b> .....	18	<b>J</b>
Commercial Service Tools .....	5	Exploded View .....	18	
<b>SYMPTOM DIAGNOSIS</b> .....	6	Removal and Installation .....	18	
<b>NOISE, VIBRATION AND HARSHNESS (NVH) TROUBLESHOOTING</b> .....	6	Inspection and Adjustment .....	19	<b>K</b>
NVH Troubleshooting Chart .....	6	<b>BRAKE PIPING</b> .....	20	
<b>PERIODIC MAINTENANCE</b> .....	7	<b>FRONT</b> .....	20	<b>L</b>
<b>BRAKE PEDAL</b> .....	7	FRONT : Exploded View .....	20	
Inspection and Adjustment .....	7	FRONT : Hydraulic Piping .....	23	
<b>BRAKE FLUID</b> .....	10	FRONT : Removal and Installation .....	24	<b>M</b>
Inspection .....	10	FRONT : Inspection .....	26	
Draining .....	10	<b>REAR</b> .....	26	<b>N</b>
Refilling .....	10	REAR : Exploded View .....	26	
Bleeding Brake System .....	11	REAR : Hydraulic Piping .....	28	
<b>BRAKE MASTER CYLINDER</b> .....	12	REAR : Removal and Installation .....	29	<b>O</b>
Inspection .....	12	REAR : Inspection .....	30	
<b>BRAKE BOOSTER</b> .....	13	<b>BRAKE MASTER CYLINDER</b> .....	31	<b>P</b>
Inspection .....	13	Exploded View .....	31	
<b>FRONT DISC BRAKE</b> .....	14	Removal and Installation .....	31	
<b>BRAKE PAD</b> .....	14	Disassembly and Assembly .....	32	
BRAKE PAD : Inspection and Adjustment .....	14	Inspection .....	33	
		<b>BRAKE BOOSTER</b> .....	34	
		Exploded View .....	34	
		Removal and Installation .....	34	
		Inspection and Adjustment .....	35	

<b>VACUUM LINES</b> .....	<b>37</b>	BRAKE PAD (1 PISTON TYPE) : Exploded View...	51
Exploded View .....	37	BRAKE PAD (1 PISTON TYPE) : Removal and Installation .....	51
Removal and Installation .....	38	BRAKE PAD (1 PISTON TYPE) : Inspection .....	52
Inspection .....	38		
<b>FRONT DISC BRAKE</b> .....	<b>39</b>	<b>BRAKE PAD (2 PISTON TYPE)</b> .....	<b>52</b>
<b>BRAKE PAD (2 PISTON TYPE)</b> .....	<b>39</b>	BRAKE PAD (2 PISTON TYPE) : Exploded View...	53
BRAKE PAD (2 PISTON TYPE) : Exploded View...	39	BRAKE PAD (2 PISTON TYPE) : Removal and Installation .....	53
BRAKE PAD (2 PISTON TYPE) : Removal and Installation .....	39	BRAKE PAD (2 PISTON TYPE) : Inspection .....	55
BRAKE PAD (2 PISTON TYPE) : Inspection .....	40	<b>BRAKE CALIPER ASSEMBLY (1 PISTON TYPE)...</b>	<b>55</b>
<b>BRAKE PAD (4 PISTON TYPE)</b> .....	<b>40</b>	BRAKE CALIPER ASSEMBLY (1 PISTON TYPE)	
BRAKE PAD (4 PISTON TYPE) : Exploded View...	41	: Exploded View .....	55
BRAKE PAD (4 PISTON TYPE) : Removal and Installation .....	41	BRAKE CALIPER ASSEMBLY (1 PISTON TYPE)	
BRAKE PAD (4 PISTON TYPE) : Inspection .....	43	: Removal and Installation .....	56
<b>BRAKE CALIPER ASSEMBLY (2 PISTON TYPE)...</b>	<b>43</b>	BRAKE CALIPER ASSEMBLY (1 PISTON TYPE)	
BRAKE CALIPER ASSEMBLY (2 PISTON TYPE)		: Disassembly and Assembly .....	57
: Exploded View .....	43	BRAKE CALIPER ASSEMBLY (1 PISTON TYPE)	
BRAKE CALIPER ASSEMBLY (2 PISTON TYPE)		: Inspection .....	59
: Removal and Installation .....	44	<b>BRAKE CALIPER ASSEMBLY (2 PISTON TYPE)...</b>	<b>59</b>
BRAKE CALIPER ASSEMBLY (2 PISTON TYPE)		BRAKE CALIPER ASSEMBLY (2 PISTON TYPE)	
: Disassembly and Assembly .....	45	: Exploded View .....	59
BRAKE CALIPER ASSEMBLY (2 PISTON TYPE)		BRAKE CALIPER ASSEMBLY (2 PISTON TYPE)	
: Inspection .....	46	: Removal and Installation .....	60
<b>BRAKE CALIPER ASSEMBLY (4 PISTON TYPE)...</b>	<b>47</b>	BRAKE CALIPER ASSEMBLY (2 PISTON TYPE)	
BRAKE CALIPER ASSEMBLY (4 PISTON TYPE)		: Disassembly and Assembly .....	61
: Exploded View .....	47	BRAKE CALIPER ASSEMBLY (2 PISTON TYPE)	
BRAKE CALIPER ASSEMBLY (4 PISTON TYPE)		: Inspection .....	63
: Removal and Installation .....	48	<b>SERVICE DATA AND SPECIFICATIONS</b>	
BRAKE CALIPER ASSEMBLY (4 PISTON TYPE)		<b>(SDS)</b> .....	<b>64</b>
: Disassembly and Assembly .....	48	<b>SERVICE DATA AND SPECIFICATIONS</b>	
BRAKE CALIPER ASSEMBLY (4 PISTON TYPE)		<b>(SDS)</b> .....	<b>64</b>
: Inspection .....	50	General Specifications .....	64
<b>REAR DISC BRAKE</b> .....	<b>51</b>	Brake Pedal .....	64
<b>BRAKE PAD (1 PISTON TYPE)</b> .....	<b>51</b>	Brake Booster .....	64
		Front Disc Brake .....	65
		Rear Disc Brake .....	65

# PRECAUTIONS

< PRECAUTION >

## PRECAUTION

### PRECAUTIONS

#### Precaution for Supplemental Restraint System (SRS) "AIR BAG" and "SEAT BELT PRE-TENSIONER"

INFOID:000000006044712

The Supplemental Restraint System such as "AIR BAG" and "SEAT BELT PRE-TENSIONER", used along with a front seat belt, helps to reduce the risk or severity of injury to the driver and front passenger for certain types of collision. This system includes seat belt switch inputs and dual stage front air bag modules. The SRS system uses the seat belt switches to determine the front air bag deployment, and may only deploy one front air bag, depending on the severity of a collision and whether the front occupants are belted or unbelted. Information necessary to service the system safely is included in the "SRS AIR BAG" and "SEAT BELT" of this Service Manual.

#### **WARNING:**

- To avoid rendering the SRS inoperative, which could increase the risk of personal injury or death in the event of a collision that would result in air bag inflation, all maintenance must be performed by an authorized NISSAN/INFINITI dealer.
- Improper maintenance, including incorrect removal and installation of the SRS, can lead to personal injury caused by unintentional activation of the system. For removal of Spiral Cable and Air Bag Module, see the "SRS AIR BAG".
- Do not use electrical test equipment on any circuit related to the SRS unless instructed to in this Service Manual. SRS wiring harnesses can be identified by yellow and/or orange harnesses or harness connectors.

#### PRECAUTIONS WHEN USING POWER TOOLS (AIR OR ELECTRIC) AND HAMMERS

#### **WARNING:**

- When working near the Air Bag Diagnosis Sensor Unit or other Air Bag System sensors with the ignition ON or engine running, DO NOT use air or electric power tools or strike near the sensor(s) with a hammer. Heavy vibration could activate the sensor(s) and deploy the air bag(s), possibly causing serious injury.
- When using air or electric power tools or hammers, always switch the ignition OFF, disconnect the battery, and wait at least 3 minutes before performing any service.

#### Precaution Necessary for Steering Wheel Rotation after Battery Disconnect

INFOID:000000006044713

#### **NOTE:**

- Before removing and installing any control units, first turn the push-button ignition switch to the LOCK position, then disconnect both battery cables.
- After finishing work, confirm that all control unit connectors are connected properly, then re-connect both battery cables.
- Always use CONSULT-III to perform self-diagnosis as a part of each function inspection after finishing work. If a DTC is detected, perform trouble diagnosis according to self-diagnosis results.

For vehicle with steering lock unit, if the battery is disconnected or discharged, the steering wheel will lock and cannot be turned.

If turning the steering wheel is required with the battery disconnected or discharged, follow the operation procedure below before starting the repair operation.

#### OPERATION PROCEDURE

1. Connect both battery cables.

#### **NOTE:**

Supply power using jumper cables if battery is discharged.

2. Turn the push-button ignition switch to ACC position.  
(At this time, the steering lock will be released.)
3. Disconnect both battery cables. The steering lock will remain released with both battery cables disconnected and the steering wheel can be turned.
4. Perform the necessary repair operation.

# PRECAUTIONS

## < PRECAUTION >

5. When the repair work is completed, re-connect both battery cables. With the brake pedal released, turn the push-button ignition switch from ACC position to ON position, then to LOCK position. (The steering wheel will lock when the push-button ignition switch is turned to LOCK position.)
6. Perform self-diagnosis check of all control units using CONSULT-III.

## Precaution for Procedure without Cowl Top Cover

INFOID:000000006044714

When performing the procedure after removing cowl top cover, cover the lower end of windshield with urethane, etc.

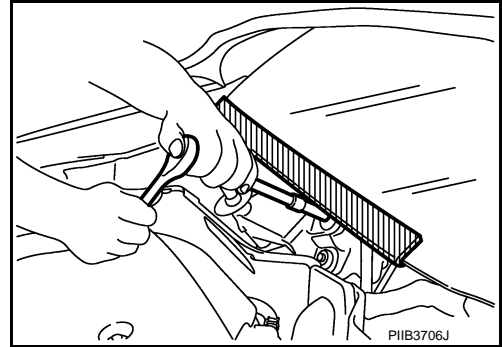

## Precaution for Brake System

INFOID:000000006038173

### **WARNING:**

**Clean any dust from the front brake and rear brake with a vacuum dust collector. Never blow with compressed air.**

- Brake fluid use refer to [MA-12, "Fluids and Lubricants"](#).
  - Never reuse drained brake fluid.
  - Never spill or splash brake fluid on painted surfaces. Brake fluid may seriously damage paint. Wipe it off immediately and wash with water if it gets on a painted surface.
  - Always confirm the specified tightening torque when installing the brake pipes.
  - After pressing the brake pedal more deeply or harder than normal driving, such as air bleeding, check each item of brake pedal. Adjust brake pedal if it is outside the standard value.
  - Always clean with new brake fluid when cleaning the master cylinder, brake caliper and other components.
  - Never use mineral oils such as gasoline or light oil to clean. They may damage rubber parts and cause improper operation.
  - Never damage caliper (made by aluminum).
  - Always loosen the brake tube flare nut with a flare nut wrench.
  - Tighten the brake tube flare nut to the specified torque with a crow-foot (A) and torque wrench (B).
  - Brake system is an important safety part. If a brake fluid leak is detected, always disassemble the affected part. If a malfunction is detected, replace part with a new one.
  - Turn the ignition switch OFF and disconnect the ABS actuator and electric unit (control unit) harness connector or the battery negative terminal before performing the work.
  - Check that no brake fluid leakage is present after replacing the parts.
  - Burnish the brake contact surfaces after refinishing or replacing rotors, after replacing pads, or if a soft pedal occurs at very low mileage.
- Front brake pad: Refer to [BR-14, "BRAKE PAD : Inspection and Adjustment"](#).
  - Front disc rotor: Refer to [BR-14, "DISC ROTOR : Inspection and Adjustment"](#).
  - Rear brake pad: Refer to [BR-16, "BRAKE PAD : Inspection and Adjustment"](#).
  - Rear disc rotor: Refer to [BR-16, "DISC ROTOR : Inspection and Adjustment"](#).

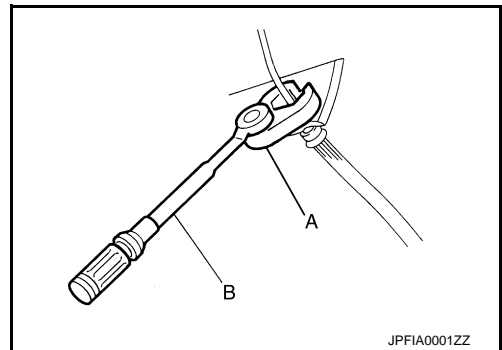

# PREPARATION



< PREPARATION >

## PREPARATION

### PREPARATION

#### Commercial Service Tools

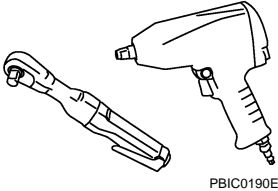
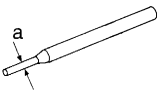
INFOID:000000006038174

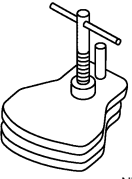
Tool name	Description
<p>Power tool</p>  <p>PBIC0190E</p>	<p>Loosening bolts and nuts</p>
<p>Pin punch a: 4 mm (0.16 in) dia.</p>  <p>NT410</p>	<p>Removing and installing reservoir tank</p>
<p>Handy vacuum pump</p>  <p>ZZC1313D</p>	<p>Checking air tight</p>
<p>Brake caliper wrench</p>  <p>NNFIA0040ZZ</p>	<p>Returning the piston for brake caliper</p>

A  
B  
C  
D  
E  
BR  
G  
H  
I  
J  
K  
L  
M  
N  
O  
P



# BRAKE PEDAL

< PERIODIC MAINTENANCE >

## PERIODIC MAINTENANCE

### BRAKE PEDAL

#### Inspection and Adjustment

INFOID:000000006038180

#### INSPECTION

##### Brake Pedal Height

Check the brake pedal height ( $H_1$ ) between the dash lower panel (1) and the brake pedal upper surface.

$H_1$  : Refer to [BR-64, "Brake Pedal"](#).

#### CAUTION:

Perform it with the floor trim removed.

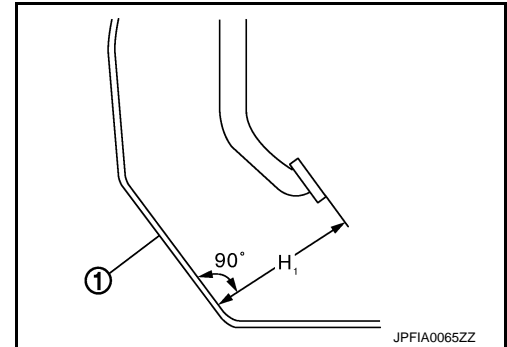

##### Stop Lamp Switch and Brake Switch

Check the clearance ( $C$ ) between the stopper rubber (1) and the stop lamp switch and brake switch (2) threaded end.

$C$  : Refer to [BR-64, "Brake Pedal"](#).

#### CAUTION:

The stop lamp must turn off when the brake pedal is released.

#### NOTE:

Pull the brake pedal pad to make the clearance between the stop lamp switch and brake switch threaded end and the stopper rubber.

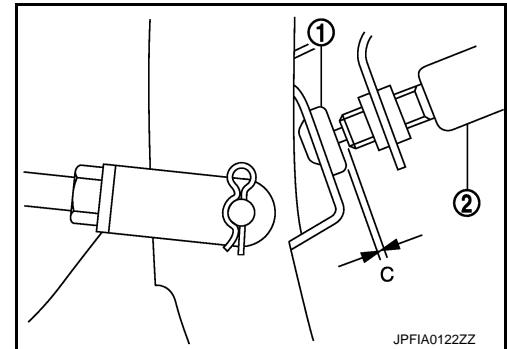

##### Brake Pedal Play

Press the brake pedal. Check the brake pedal play ( $A$ ) (stroke until fluid pressure occurs).

$A$  : Refer to [BR-64, "Brake Pedal"](#).

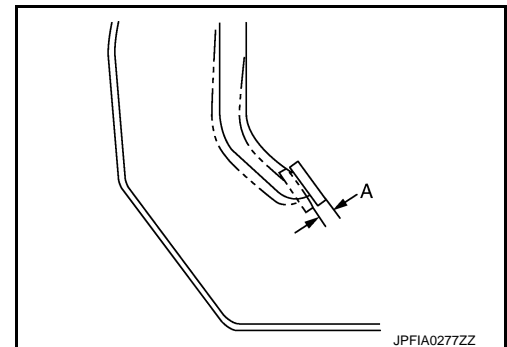

##### Depressed Brake Pedal Height

Check the height between the dash lower panel (1) and the top face of the brake pedal ( $H_2$ ) when depressing the brake pedal with a force of 490 N (50 kg, 110 lb) while the engine is running.

$H_2$  : Refer to [BR-64, "Brake Pedal"](#).

#### CAUTION:

Perform it with the floor trim removed.

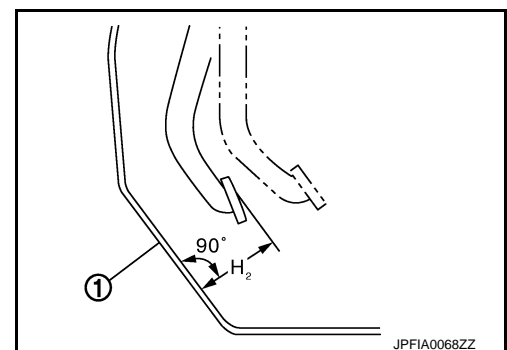

#### ADJUSTMENT

A  
B  
C  
D  
E  
BR  
G  
H  
I  
J  
K  
L  
M  
N  
O  
P

# BRAKE PEDAL

## < PERIODIC MAINTENANCE >

### Brake Pedal Height

1. Remove instrument lower panel LH. Refer to [IP-13, "Removal and Installation"](#).
2. Disconnect the stop lamp switch harness connector and the brake switch harness connector.
3. Loosen the stop lamp switch and brake switch by turning it 45° counterclockwise.
4. Loosen the input rod lock nut (1).
5. Rotate the input rod (2), and adjust the brake pedal to the specified height.

**CAUTION:**

The threaded end of the input rod must project to the inner side of the clevis (3).

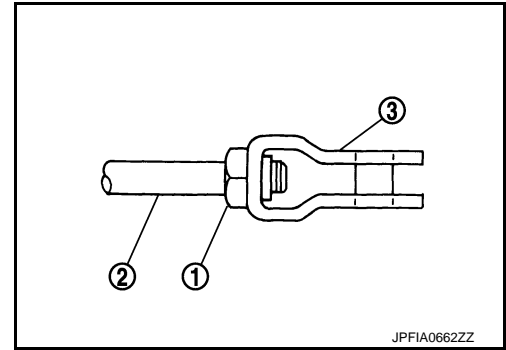

**H<sub>1</sub>** : Refer to [BR-64, "Brake Pedal"](#).

6. Tighten the lock nut. Refer to [BR-34, "Exploded View"](#).
7. Adjust the clearance between the stopper rubber and the stop lamp switch and brake switch threaded end after adjusting the brake pedal height.

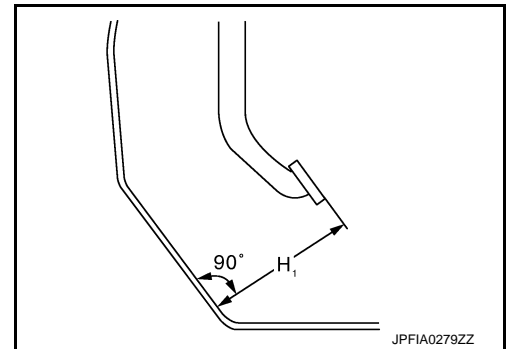

### Stop Lamp Switch and Brake Switch

1. Remove instrument lower panel LH. Refer to [IP-13, "Removal and Installation"](#).
2. Disconnect the stop lamp switch harness connector and the brake switch harness connector.
3. Loosen the stop lamp switch and brake switch by turning it 45° counterclockwise.
4. Press-fit the stop lamp switch and brake switch (2) until the stop lamp switch and brake switch hits the stopper rubber (1) 45° clockwise while pulling the brake pedal pad slightly.

**CAUTION:**

• The clearance (C) between the stopper rubber and stop lamp switch and brake switch threaded end and must be the specified value.

**C** : Refer to [BR-64, "Brake Pedal"](#).

• The stop lamp must turn off when the brake pedal is released.

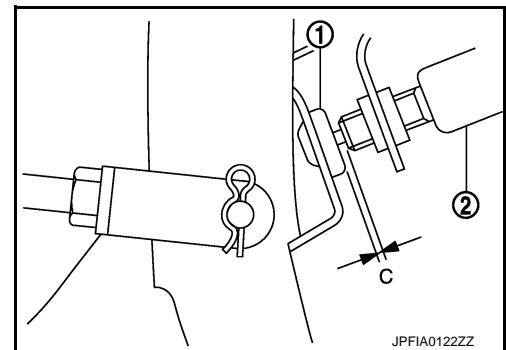

### Brake Pedal Play

1. Remove instrument lower panel LH. Refer to [IP-13, "Removal and Installation"](#).
2. Disconnect the stop lamp switch harness connector and the brake switch harness connector.
3. Loosen the stop lamp switch and brake switch by turning it 45° counterclockwise.



# BRAKE PEDAL

## < PERIODIC MAINTENANCE >

4. Press-fit the stop lamp switch and brake switch (2) until the stop lamp switch and brake switch hits the stopper rubber (1) 45° clockwise while pulling the brake pedal pad slightly.

**CAUTION:**

- The clearance (C) between the stopper rubber and stop lamp switch and brake switch threaded end and must be the specified value.

**C** : Refer to [BR-64, "Brake Pedal"](#).

- The stop lamp must turn off when the brake pedal is released.

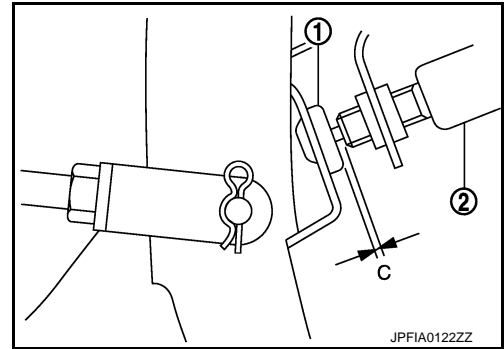

### Depressed Brake Pedal Height

1. Perform the air bleeding. Refer to [BR-11, "Bleeding Brake System"](#).
2. Check the height between the dash lower panel (1) and the top face of the brake pedal (H<sub>2</sub>) when depressing the brake pedal with a force of 490 N (50 kg, 110 lb) while the engine is running.

**H<sub>2</sub>** : Refer to [BR-64, "Brake Pedal"](#).

**CAUTION:**

**Perform it with the floor trim removed.**

3. Adjust the brake pedal play after adjusting the brake pedal height, clearance between the stopper rubber and the stop lamp switch and brake switch threaded end.

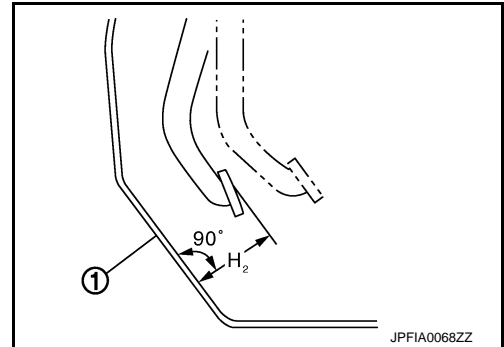

A  
B  
C  
D  
E  
BR  
G  
H  
I  
J  
K  
L  
M  
N  
O  
P

# BRAKE FLUID

< PERIODIC MAINTENANCE >

## BRAKE FLUID

### Inspection

INFOID:000000006038182

#### BRAKE FLUID LEVEL

- Check that the fluid level in the reservoir tank is within the specified range (MAX – MIN lines).
- Visually check for any brake fluid leakage around the reservoir tank.
- Check the brake system for any leakage if the fluid level is extremely low (lower than MIN).
- Check the brake system for fluid leakage if the warning lamp remains illuminated even after the parking brake is released.
- Check the reservoir tank for the mixing of foreign matter (e.g. dust) and oils other than brake fluid.

#### BRAKE LINE

1. Check brake line (tubes and hoses) for cracks, deterioration or other damage. Replace any damaged parts.
2. Depress the brake pedal with a force of 490 N (50 kg, 110 lb) and hold down the pedal for approx. 5 seconds with the engine running. Check for any fluid leakage.

#### **CAUTION:**

**Retighten the applicable connection to the specified torque and repair any abnormal (damaged, worn or deformed) part if any brake fluid leakage is present.**

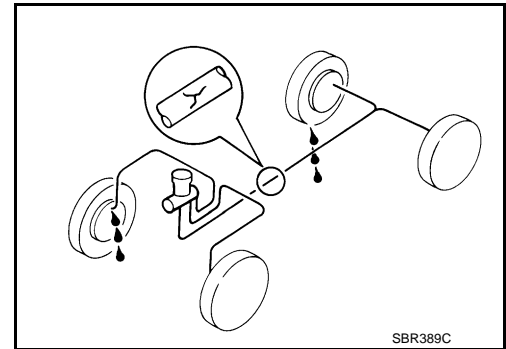

### Draining

INFOID:000000006038183

#### **CAUTION:**

- Never spill or splash brake fluid on painted surfaces. Brake fluid may seriously damage paint. Wipe it off immediately and wash with water if it gets on a painted surface.
- Turn the ignition switch OFF and disconnect the ABS actuator and electric unit (control unit) connector or the battery negative terminal before performing work.
- If the brake fluid adheres to the brake caliper assembly and disc rotor, quickly wipe it off.

1. Connect a vinyl tube to the bleed valve.
2. Depress the brake pedal and loosen the bleeder valve to gradually discharge brake fluid.

#### **CAUTION:**

**Cover crowfoot and flare nut wrench with a cloth as not to damage the brake caliper assembly.**

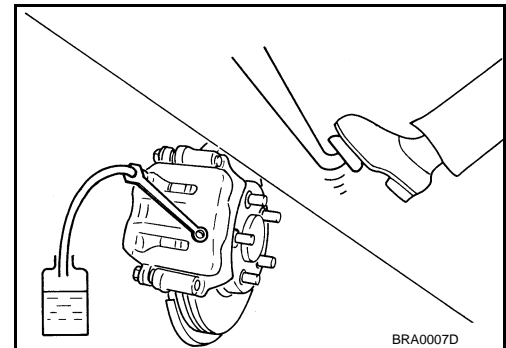

### Refilling

INFOID:000000006038184

#### **CAUTION:**

- Turn the ignition switch OFF and disconnect the ABS actuator and electric unit (control unit) connector or the battery negative terminal before performing work.
- If the brake fluid adheres to the brake caliper assembly and disc rotor, quickly wipe it off.

1. Check that there is no foreign material in the reservoir tank, and refill with new brake fluid.

#### **CAUTION:**

- Never reuse drained brake fluid.
- Never allow oils other than brake fluid to enter the reservoir tank.

# BRAKE FLUID

## < PERIODIC MAINTENANCE >

2. Loosen the bleeder valve, slowly depress the brake pedal to the full stroke, and then release the pedal. Repeat this operation at intervals of 2 or 3 seconds until all brake fluid is discharged. Then close the bleeder valve with the brake pedal depressed. Repeat the same work on each wheel.

**CAUTION:**

**Cover crowfoot and flare nut wrench with a cloth as not to damage the brake caliper assembly.**

3. Perform the air bleeding. Refer to [BR-11, "Bleeding Brake System"](#).

## Bleeding Brake System

INFOID:000000006038185

**CAUTION:**

- Turn the ignition switch OFF and disconnect the ABS actuator and electric unit (control unit) connector or the battery negative terminal before performing work.
- Monitor the fluid level in the reservoir tank while performing the air bleeding.
- If the brake fluid adheres to the brake caliper assembly and disc rotor, quickly wipe it off.

1. Check that there is no foreign material in the reservoir tank, and refill with new brake fluid.

**CAUTION:**

- Never reuse drained brake fluid.
- Never allow oils other than brake fluid to enter the reservoir tank.

2. Connect a vinyl tube to the bleeder valve of the rear right brake.
3. Fully depress the brake pedal 4 to 5 times.
4. Loosen the bleeder valve and bleed air with the brake pedal depressed, and then quickly tighten the bleeder valve.

**CAUTION:**

**Cover crowfoot and flare nut wrench with a cloth as not to damage the brake caliper assembly.**

5. Repeat steps 3 and 4 until all of the air is out of the brake line.
6. Tighten the bleeder valve to the specified torque.
  - Front disc brake
    - 2 piston type: Refer to [BR-43, "BRAKE CALIPER ASSEMBLY \(2 PISTON TYPE\) : Exploded View"](#).
    - 4 piston type: Refer to [BR-47, "BRAKE CALIPER ASSEMBLY \(4 PISTON TYPE\) : Exploded View"](#).
  - Rear disc brake
    - 1 piston type: Refer to [BR-55, "BRAKE CALIPER ASSEMBLY \(1 PISTON TYPE\) : Exploded View"](#).
    - 2 piston type: Refer to [BR-59, "BRAKE CALIPER ASSEMBLY \(2 PISTON TYPE\) : Exploded View"](#).
7. Repeat steps 1 to 6. Occasionally fill with the brake fluid in order to keep the reservoir tank at least half full. Bleed air in the following order: rear right brake → front left brake → rear left brake → and front right brake.
8. Check that the fluid level in the reservoir tank is within the specified range after air bleeding.
9. Check each item of brake pedal. Adjust it if the measurement value is not the standard. Refer to [BR-7, "Inspection and Adjustment"](#).

## BRAKE MASTER CYLINDER

< PERIODIC MAINTENANCE >

---

### BRAKE MASTER CYLINDER

#### Inspection

*INFOID:000000006038187*

#### FLUID LEAK

Check for brake fluid leakage from the master cylinder mounting face, reservoir tank mounting face and brake tube connections.

# BRAKE BOOSTER

< PERIODIC MAINTENANCE >

## BRAKE BOOSTER

### Inspection

INFOID:000000006038188

### OPERATION

Depress the brake pedal several times at 5-second intervals with the engine stopped. Start the engine with the brake pedal fully depressed. Check that the clearance between brake pedal and dash lower panel decreases.

#### **NOTE:**

A slight impact with a small click may be felt on the pedal when the brake pedal is fully depressed. This is a normal phenomenon due to the brake system operation.

### AIR TIGHT

1. Run the engine for 1 minute to apply vacuum to the brake booster, and stop the engine. Then depress the brake pedal several times at 5-second intervals until the accumulated vacuum is released to atmospheric pressure. Check that the clearance between brake pedal and dash lower panel gradually increases each time the brake pedal is depressed when performing this operation.
2. Depress the brake pedal with the engine running. Then stop the engine while holding down the brake pedal. Check that the brake pedal stroke does not change after holding down the brake pedal for 30 seconds or more.

#### **NOTE:**

A slight impact with a small click may be felt on the pedal when the brake pedal is fully depressed. This is a normal phenomenon due to the brake system operation.

A  
B  
C  
D  
E  
BR  
G  
H  
I  
J  
K  
L  
M  
N  
O  
P

# FRONT DISC BRAKE

< PERIODIC MAINTENANCE >

## FRONT DISC BRAKE

### BRAKE PAD

#### BRAKE PAD : Inspection and Adjustment

INFOID:000000006038189

#### INSPECTION

##### 2 Piston Type

Check the brake pad wear thickness from an inspection hole on cylinder body. Check using a scale if necessary.

**Wear thickness** : Refer to [BR-65, "Front Disc Brake"](#).

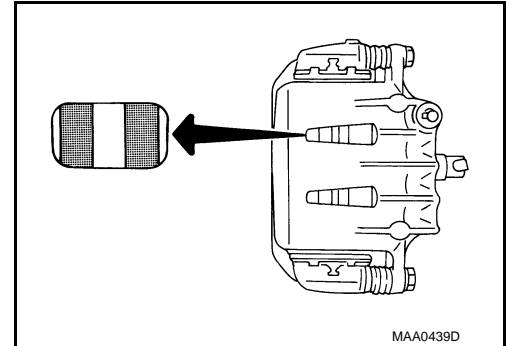

##### 4 Piston Type

Check the thickness of brake pad from the inspection hole on caliper. Check use a scale if necessary.

**Wear thickness** : Refer to [BR-65, "Front Disc Brake"](#).

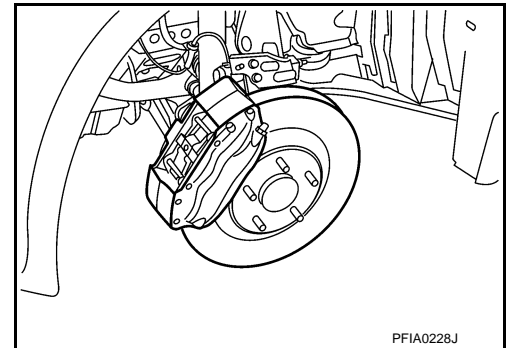

#### ADJUSTMENT

##### **CAUTION:**

- **Burnish contact surfaces between pads according to the following procedure after refinishing or replacing brake pads, or if a soft pedal occurs at very low mileage.**
- **Be careful of vehicle speed because the brake does not operate firmly/securely until pads and disc rotor are securely fitted.**
- **Only perform this procedure under safe road and traffic conditions. Use extreme caution.**

1. Drive vehicle on straight, flat road.
2. Depress brake pedal with the power to stop vehicle within 3 to 5 seconds until the vehicle stops.
3. Drive without depressing brake for a few minutes to cool the brake.
4. Repeat steps 1 to 3 until pad and disc rotor are securely fitted.

### DISC ROTOR

#### DISC ROTOR : Inspection and Adjustment

INFOID:000000006038191

#### INSPECTION

##### Appearance

Check surface of disc rotor for uneven wear, cracks, and serious damage. Replace it if necessary. Refer to [FAX-7, "Removal and Installation"](#) (2WD), [FAX-17, "Removal and Installation"](#) (AWD).

##### Runout

1. Fix the disc rotor to the wheel hub and bearing assembly with wheel nuts (2 points at least).
2. Check the wheel bearing axial end play before the inspection. Refer to [FAX-6, "Inspection"](#) (2WD), [FAX-18, "Inspection"](#) (AWD).

# FRONT DISC BRAKE

## < PERIODIC MAINTENANCE >

3. Inspect the runout with a dial indicator to measure at 10 mm (0.39 in) inside the disc edge.

**Runout** : Refer to [BR-65, "Front Disc Brake"](#).

4. Find the installation position that has a minimum runout by shifting the disc rotor-to-wheel hub and bearing assembly installation position by one hole at a time if the runout exceeds the limit value.
5. Refinish the disc rotor if the runout is outside the limit even after performing the above operation. [When refinishing, use the Pro-Cut PEM On-Car brake Lathe (Tool No. 38-PFM90.5) or equivalent.]

### CAUTION:

- Check in advance that the thickness of the disc rotor is wear thickness + 0.3 mm (0.12 in) or more.
- If the thickness is less than wear thickness + 0.3 mm (0.012 in), replace the disc rotor. Refer to [FAX-7, "Removal and Installation"](#) (2WD), [FAX-17, "Removal and Installation"](#) (AWD).

**Wear thickness** : Refer to [BR-65, "Front Disc Brake"](#).

### Thickness

Check the thickness of the disc rotor using a micrometer. Replace the disc rotor if the thickness is below the wear limit. Refer to [FAX-7, "Removal and Installation"](#) (2WD), [FAX-17, "Removal and Installation"](#) (AWD).

**Wear thickness** : Refer to [BR-65, "Front Disc Brake"](#).

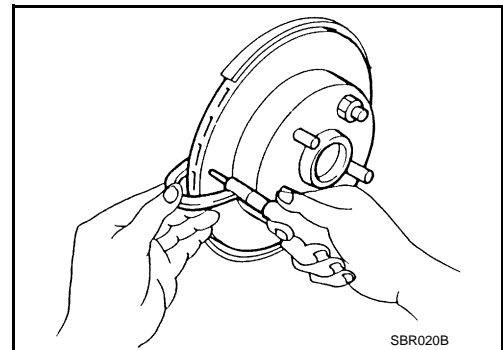
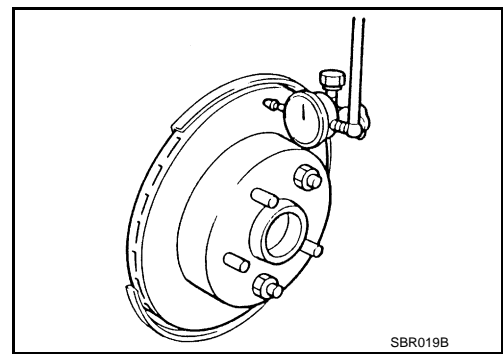

## ADJUSTMENT

### CAUTION:

- Burnish contact surfaces between pads according to the following procedure after refinishing or replacing pads, or if a soft pedal occurs at very low mileage.
  - Be careful of vehicle speed because the brake does not operate firmly/securely until pads and disc rotor are securely fitted.
  - Only perform this procedure under safe road and traffic conditions. Use extreme caution.
1. Drive vehicle on straight, flat road.
  2. Depress brake pedal with the power to stop vehicle within 3 to 5 seconds until the vehicle stops.
  3. Drive without depressing brake for a few minutes to cool the brake.
  4. Repeat steps 1 to 3 until pad and disc rotor are securely fitted.

# REAR DISC BRAKE

< PERIODIC MAINTENANCE >

## REAR DISC BRAKE

### BRAKE PAD

#### BRAKE PAD : Inspection and Adjustment

INFOID:000000006038192

#### INSPECTION

##### 1 Piston Type

Check the brake pad wear thickness from an inspection hole on cylinder body. Check using a scale if necessary.

**Wear thickness** : Refer to [BR-65, "Rear Disc Brake"](#).

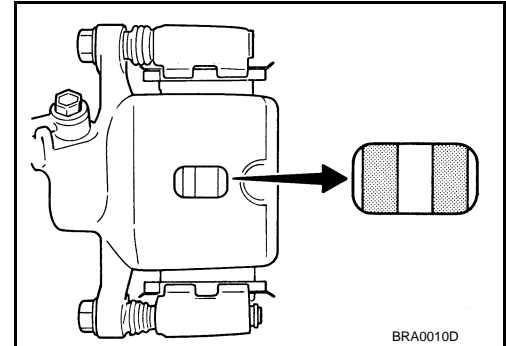

##### 2 Piston Type

Check the thickness of brake pad from the inspection hole on caliper. Check use a scale if necessary.

**Wear thickness** : Refer to [BR-65, "Rear Disc Brake"](#).

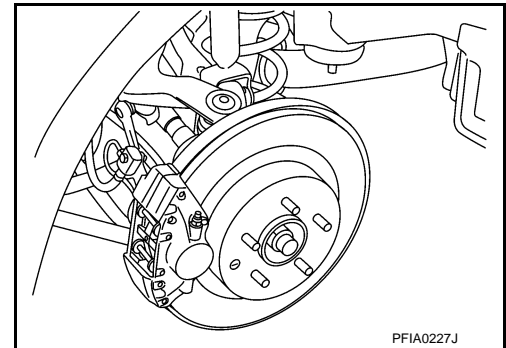

#### ADJUSTMENT

##### **CAUTION:**

- **Burnish contact surfaces between pads according to the following procedure after refinishing or replacing brake pads, or if a soft pedal occurs at very low mileage.**
- **Be careful of vehicle speed because the brake does not operate firmly/securely until pads and disc rotor are securely fitted.**
- **Only perform this procedure under safe road and traffic conditions. Use extreme caution.**

1. Drive vehicle on straight, flat road.
2. Depress brake pedal with the power to stop vehicle within 3 to 5 seconds until the vehicle stops.
3. Drive without depressing brake for a few minutes to cool the brake.
4. Repeat steps 1 to 3 until pad and disc rotor are securely fitted.

### DISC ROTOR

#### DISC ROTOR : Inspection and Adjustment

INFOID:000000006038194

#### INSPECTION

##### Appearance

Check surface of disc rotor for uneven wear, cracks, and serious damage. Replace it if necessary. Refer to [RAX-8, "Removal and Installation"](#).

##### Runout

1. Fix the disc rotor to the wheel hub and bearing assembly with wheel nuts (2 points at least).
2. Check the wheel bearing axial end play before the inspection. Refer to [RAX-8, "Removal and Installation"](#).



# REAR DISC BRAKE

## < PERIODIC MAINTENANCE >

3. Inspect the runout with a dial indicator to measure at 10 mm (0.39 in) inside the disc edge.

**Runout** : Refer to [BR-65, "Rear Disc Brake"](#).

4. Find the installation position that has a minimum runout by shifting the disc rotor-to-wheel hub and bearing assembly installation position by one hole at a time if the runout exceeds the limit value.
5. Refinish the disc rotor if the runout is outside the limit even after performing the above operation. [When refinishing, use the Pro-Cut PEM On-Car brake Lathe (Tool No. 38-PFM90.5) or equivalent.]

**CAUTION:**

- Check in advance that the thickness of the disc rotor is wear thickness + 0.3 mm (0.12 in) or more.
- If the thickness is less than wear thickness + 0.3 mm (0.012 in), replace the disc rotor. Refer to [RAX-8, "Removal and Installation"](#).

**Wear thickness** : Refer to [BR-65, "Rear Disc Brake"](#).

### Thickness

Check the thickness of the disc rotor using a micrometer. Replace the disc rotor if the thickness is below the wear limit. Refer to [RAX-8, "Removal and Installation"](#).

**Wear thickness** : Refer to [BR-65, "Rear Disc Brake"](#).

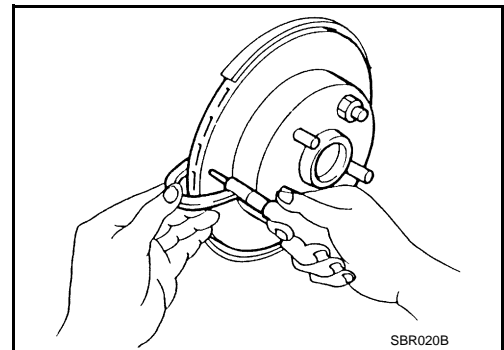
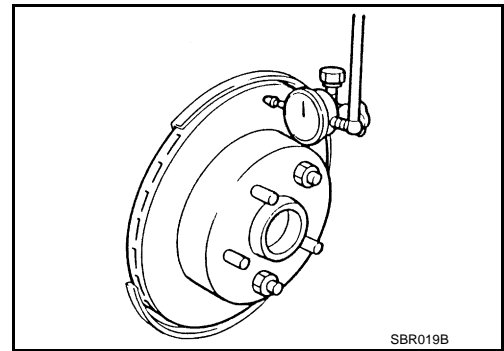

## ADJUSTMENT

**CAUTION:**

- Burnish contact surfaces between pads according to the following procedure after refinishing or replacing pads, or if a soft pedal occurs at very low mileage.
  - Be careful of vehicle speed because the brake does not operate firmly/securely until pads and disc rotor are securely fitted.
  - Only perform this procedure under safe road and traffic conditions. Use extreme caution.
1. Drive vehicle on straight, flat road.
  2. Depress brake pedal with the power to stop vehicle within 3 to 5 seconds until the vehicle stops.
  3. Drive without depressing brake for a few minutes to cool the brake.
  4. Repeat steps 1 to 3 until pad and disc rotor are securely fitted.

# BRAKE PEDAL

< REMOVAL AND INSTALLATION >

## REMOVAL AND INSTALLATION

### BRAKE PEDAL

Exploded View

INFOID:000000006038195

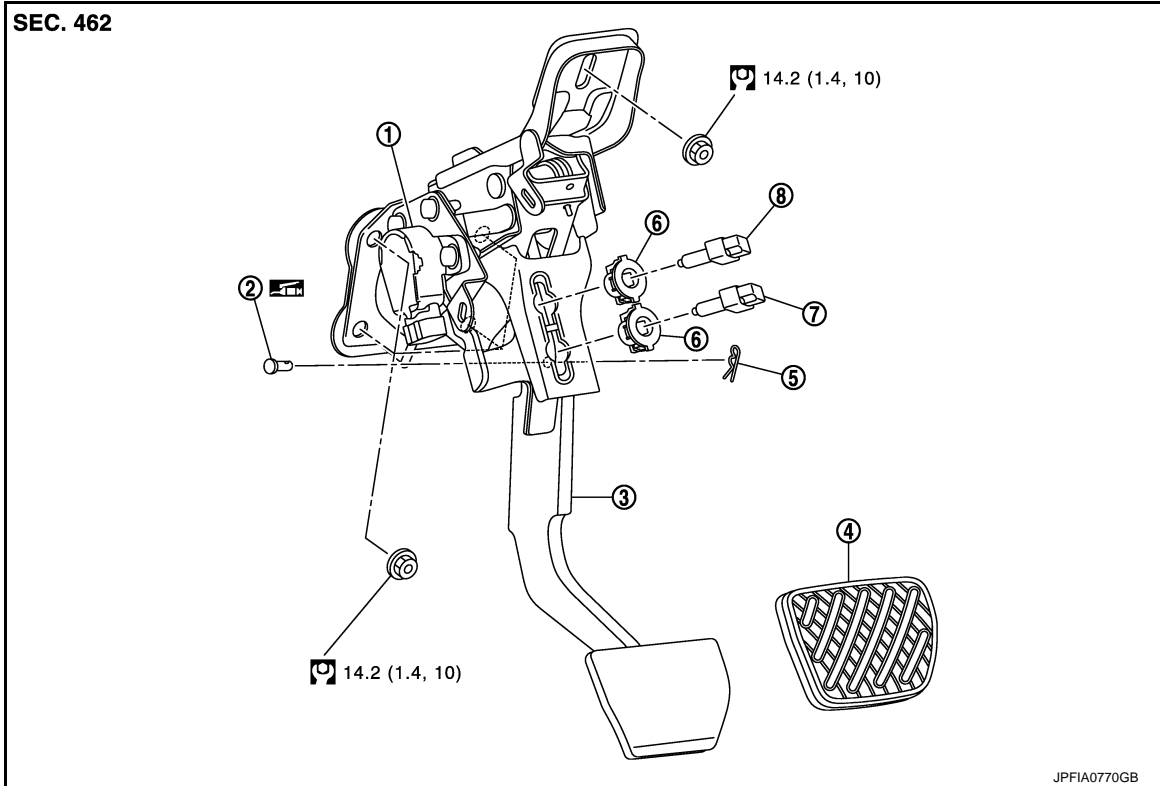

- |   |                     |                         |
|---|---------------------|-------------------------|
| 1. Brake pedal stroke sensor (with pre-crash seat belt) | 2. Clevis pin       | 3. Brake pedal assembly |
| 4. Brake pedal pad                                      | 5. Snap pin         | 6. Clip                 |
| 7. Brake switch   | 8. Stop lamp switch |                         |

 Apply multi-purpose grease.

Refer to [GI-4, "Components"](#) for symbols not described on the above.

## Removal and Installation

INFOID:000000006038196

### REMOVAL

#### CAUTION:

**Never removing brake pedal stroke sensor. (With pre-crash seat belt)**

1. Perform 4WAS front actuator neutral position adjustment (with 4WAS). Refer to [STC-87, "Work Procedure \(Pattern 1\)"](#).
2. Remove the instrument lower panel LH. Refer to [JP-13, "Removal and Installation"](#).
3. Disconnect the brake pedal stroke sensor harness connector. (With pre-crash seat belt)
4. Disconnect the stop lamp switch harness connector and brake switch harness connectors.
5. Rotate the stop lamp switch and the brake switch counterclockwise to remove.
6. Remove the accelerator pedal (with 4WAS). Refer to [ACC-3, "MODELS WITHOUT DISTANCE CONTROL ASSIST SYSTEM : Removal and Installation"](#) (without distance control assist system), [ACC-4, "MODELS WITH DISTANCE CONTROL ASSIST SYSTEM : Removal and Installation"](#) (with distance control assist system).
7. Remove the lower shaft (with 4WAS). Refer to [ST-41, "WITH 4WAS : Removal and Installation"](#).
8. Remove the snap pin, and then remove the clevis pin from the clevis of brake booster.

# BRAKE PEDAL

## < REMOVAL AND INSTALLATION >

9. Remove the BCM. Refer to [BCS-79, "Removal and Installation"](#).
10. Remove the brake pedal assembly.

### CAUTION:

**Hold the brake booster and master cylinder so as not to drop out or contact them other parts.**

11. Perform inspection after removal. Refer to [BR-19, "Inspection and Adjustment"](#).

## INSTALLATION

Note the following, and install in the reverse order of removal.

- Apply the multi-purpose grease to the clevis pin and the matching faces.

### NOTE:

The clevis pin may be inserted in either direction.

- Perform adjustment after installation. Refer to [BR-19, "Inspection and Adjustment"](#).

## Inspection and Adjustment

INFOID:000000006038197

## INSPECTION AFTER REMOVAL

- Check for the following items and replace the brake pedal assembly if necessary.
  - Check the brake pedal upper rivet (made by aluminum) (B) for deformation.
  - Check the brake pedal for bend, damage, and cracks on the welded parts.
  - Check the lapping length (A) of sub-bracket (1) and slide plate (2).

**A : 5.0 mm (0.197 in) or more**

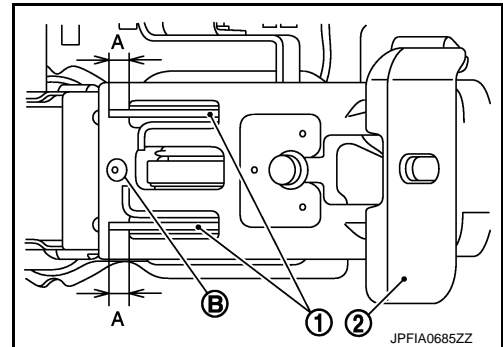

- Check clevis pin and plastic stopper (A) for damage and deformation. If any is found, replace clevis pin.

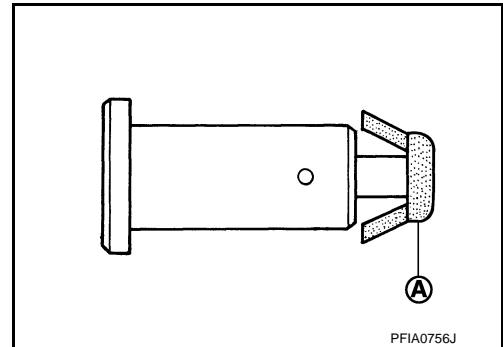

## ADJUSTMENT AFTER INSTALLATION

- Perform the brake pedal adjustment after installing the brake pedal assembly. Refer to [BR-7, "Inspection and Adjustment"](#).
- Perform 4WAS front actuator neutral position adjustment (with 4WAS). Refer to [STC-87, "Work Procedure \(Pattern 2\)"](#).

# BRAKE PIPING

< REMOVAL AND INSTALLATION >

## BRAKE PIPING

### FRONT

FRONT : Exploded View

INFOID:000000006038198

2 PISTON TYPE

Without ICC

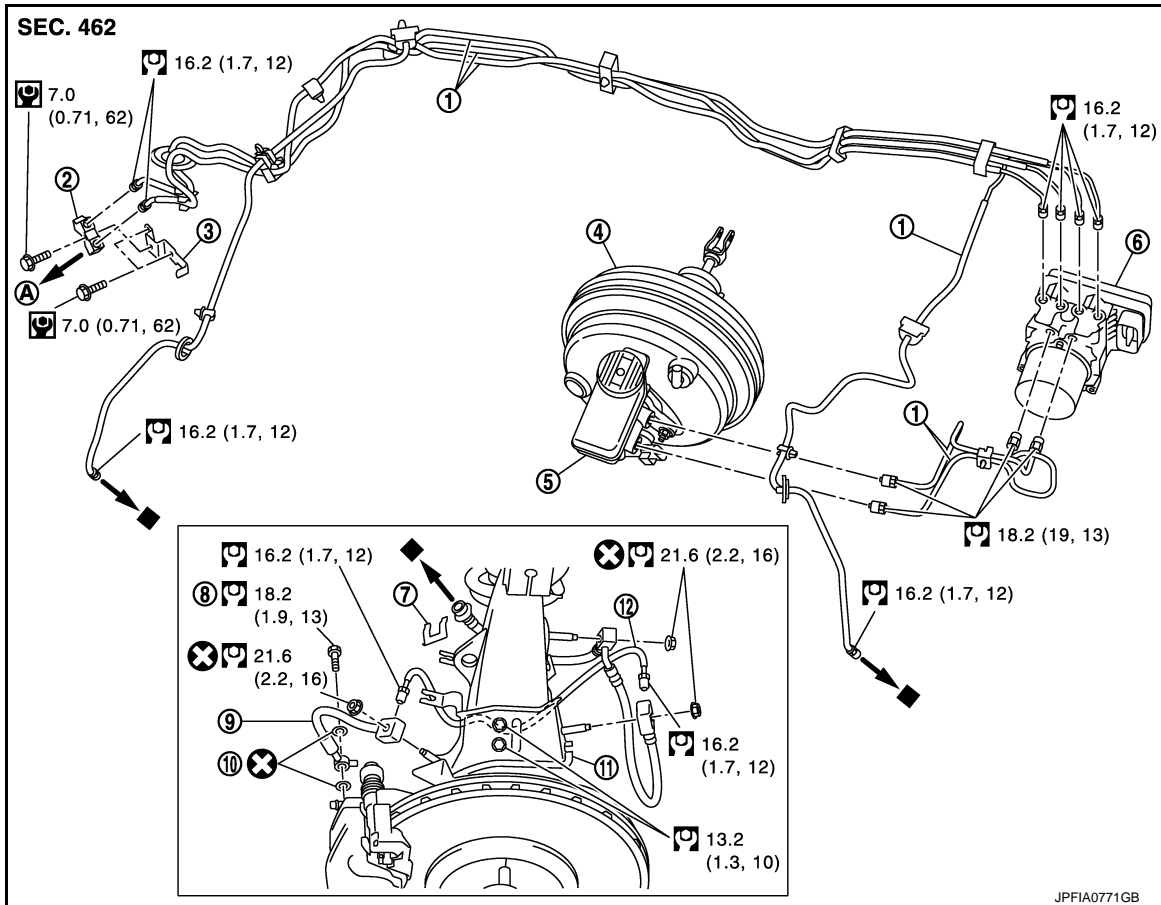

- |                   |                             |  |
|-------------------|-----------------------------|--|
| 1. Brake tube     | 2. Connector                | 3. Connector bracket                             |
| 4. Brake booster  | 5. Master cylinder assembly | 6. ABS actuator and electric unit (control unit) |
| 7. Lock plate     | 8. Union bolt               | 9. Brake hose                                    |
| 10. Copper washer | 11. Brake hose bracket      | 12. Brake tube                                   |
- A. To rear brake tube

Refer to [GI-4. "Components"](#) for symbols in the figure.

# BRAKE PIPING

< REMOVAL AND INSTALLATION >

With ICC

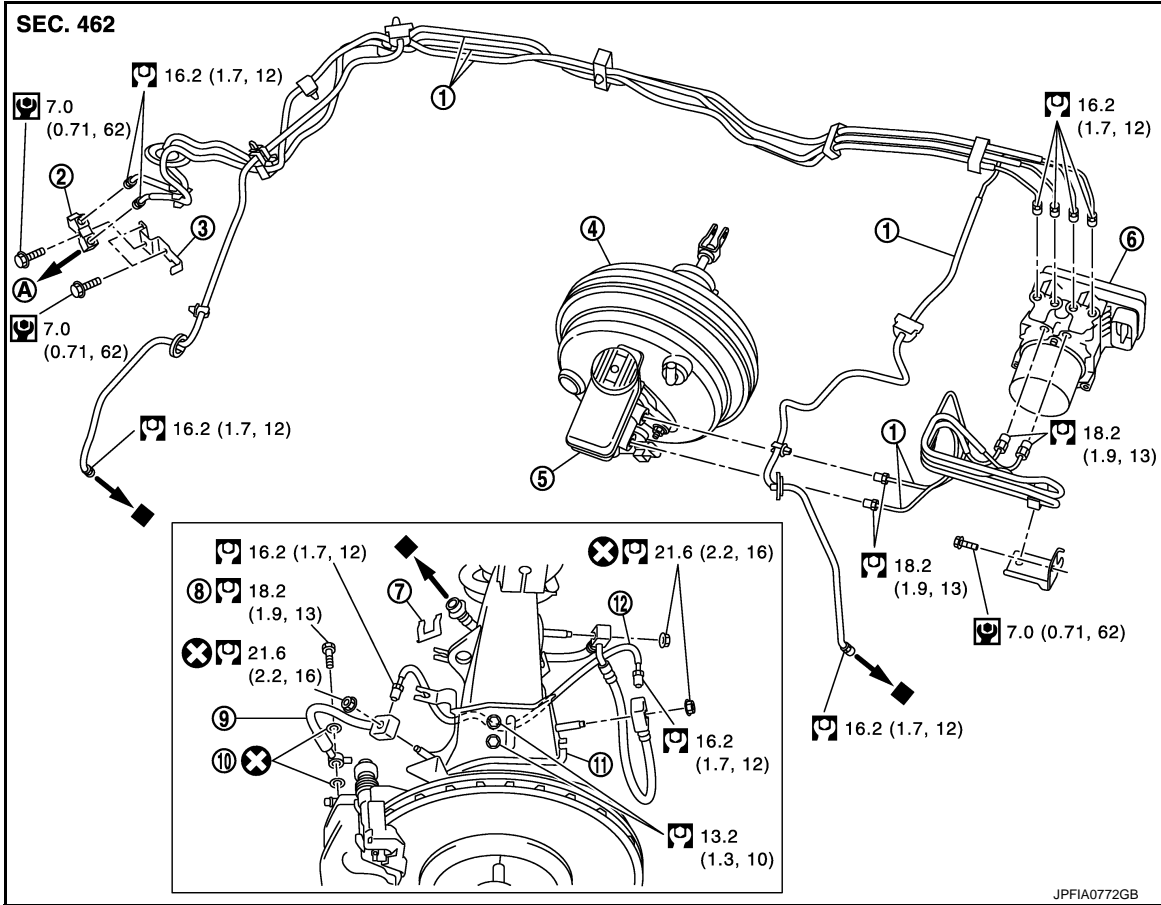

- |                       |                             |  |
|-----------------------|-----------------------------|--|
| 1. Brake tube         | 2. Connector                | 3. Connector bracket                             |
| 4. Brake booster      | 5. Master cylinder assembly | 6. ABS actuator and electric unit (control unit) |
| 7. Lock plate         | 8. Union bolt               | 9. Brake hose                                    |
| 10. Copper washer     | 11. Brake hose bracket      | 12. Brake tube                                   |
| A. To rear brake tube |                             |  |

Refer to [GI-4, "Components"](#) for symbols in the figure.

## 4 PISTON TYPE

A  
B  
C  
D  
E  
BR  
G  
H  
I  
J  
K  
L  
M  
N  
O  
P

# BRAKE PIPING

< REMOVAL AND INSTALLATION >

Without ICC

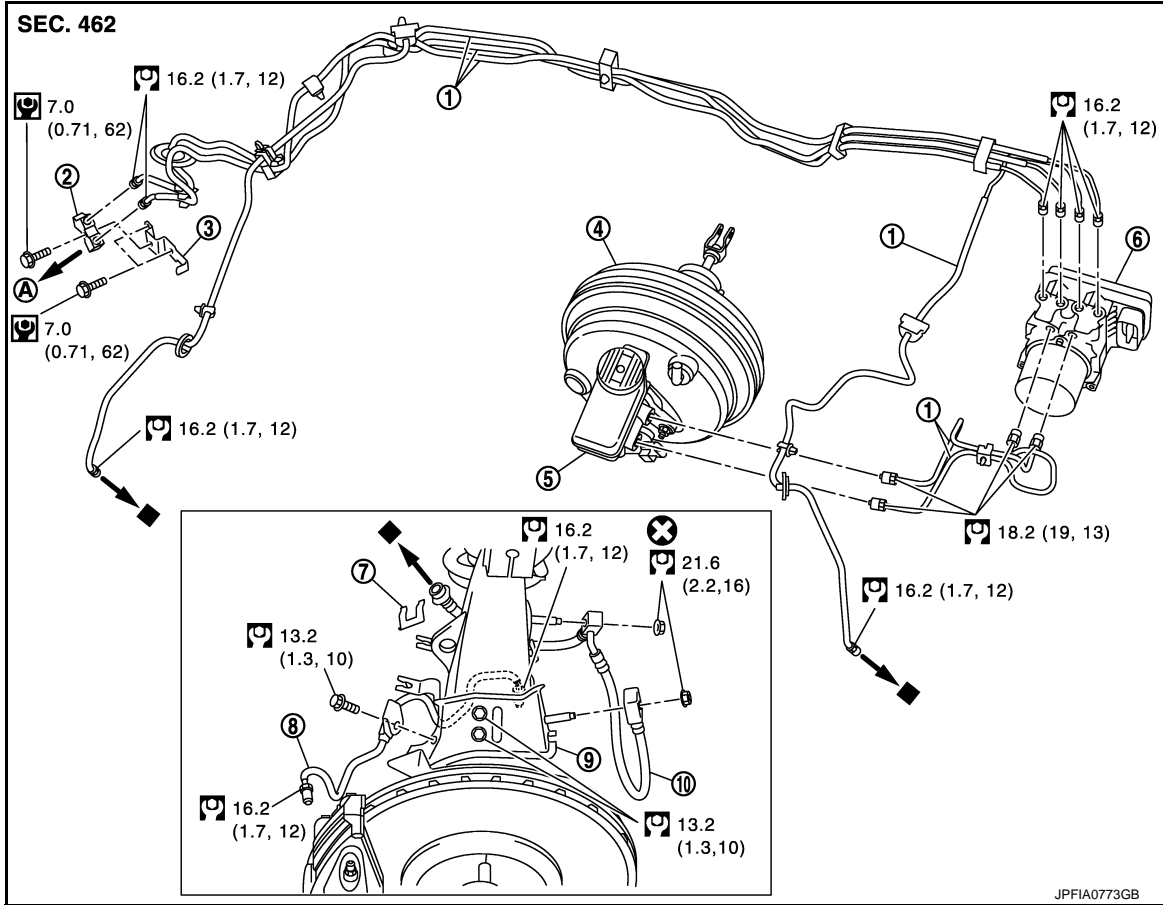

JPFIA0773GB

- |                       |                             |  |
|-----------------------|-----------------------------|--|
| 1. Brake tube         | 2. Connector                | 3. Connector bracket                             |
| 4. Brake booster      | 5. Master cylinder assembly | 6. ABS actuator and electric unit (control unit) |
| 7. Lock plate         | 8. Brake tube               | 9. Brake hose bracket                            |
| 10. Brake hose        |                             |  |
| A. To rear brake tube |                             |  |

Refer to [GI-4, "Components"](#) for symbols in the figure.

# BRAKE PIPING

< REMOVAL AND INSTALLATION >

With ICC

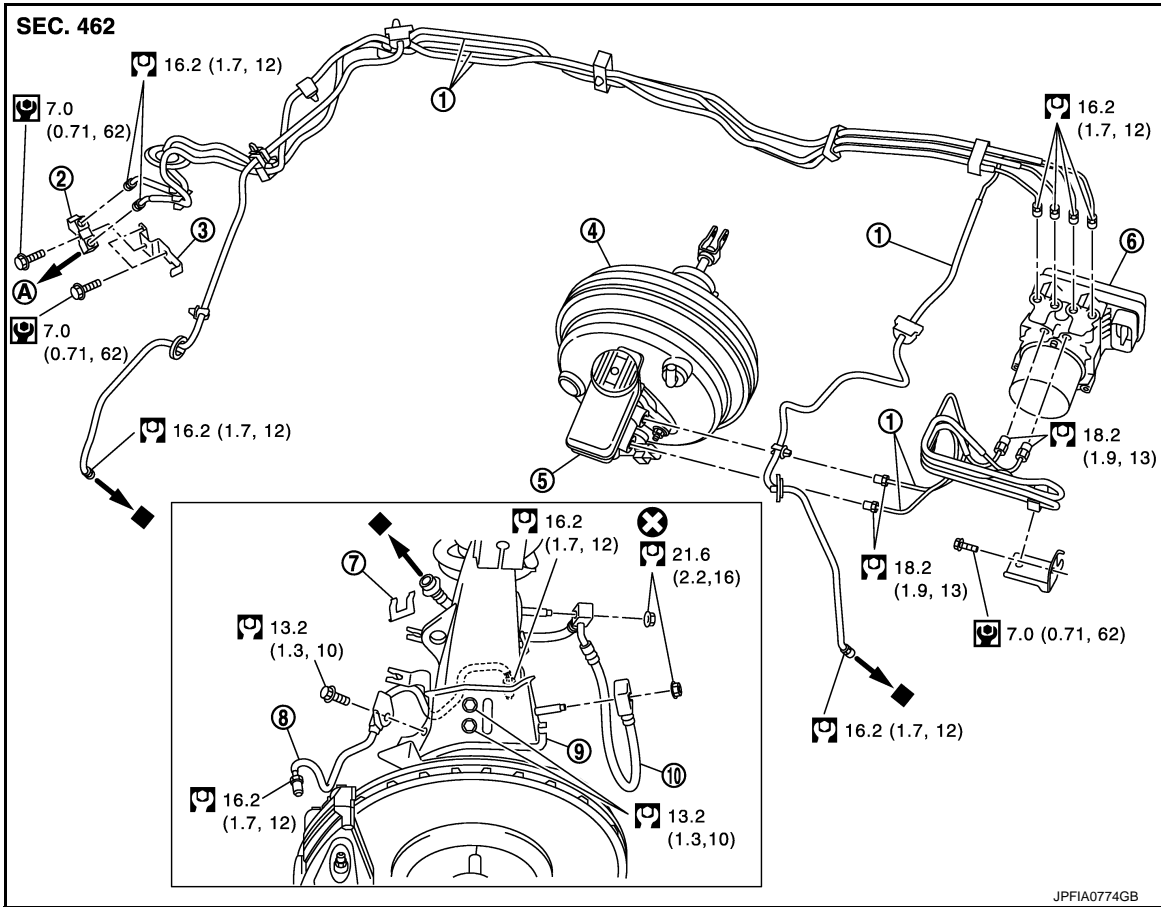

- |                       |                             |  |
|-----------------------|-----------------------------|--|
| 1. Brake tube         | 2. Connector                | 3. Connector bracket                             |
| 4. Brake booster      | 5. Master cylinder assembly | 6. ABS actuator and electric unit (control unit) |
| 7. Lock plate         | 8. Brake tube               | 9. Brake hose bracket                            |
| 10. Brake hose        |                             |  |
| A. To rear brake tube |                             |  |

Refer to [GI-4, "Components"](#) for symbols in the figure.

## FRONT : Hydraulic Piping

INFOID:0000000006038199

2 PISTON TYPE

# BRAKE PIPING

## < REMOVAL AND INSTALLATION >

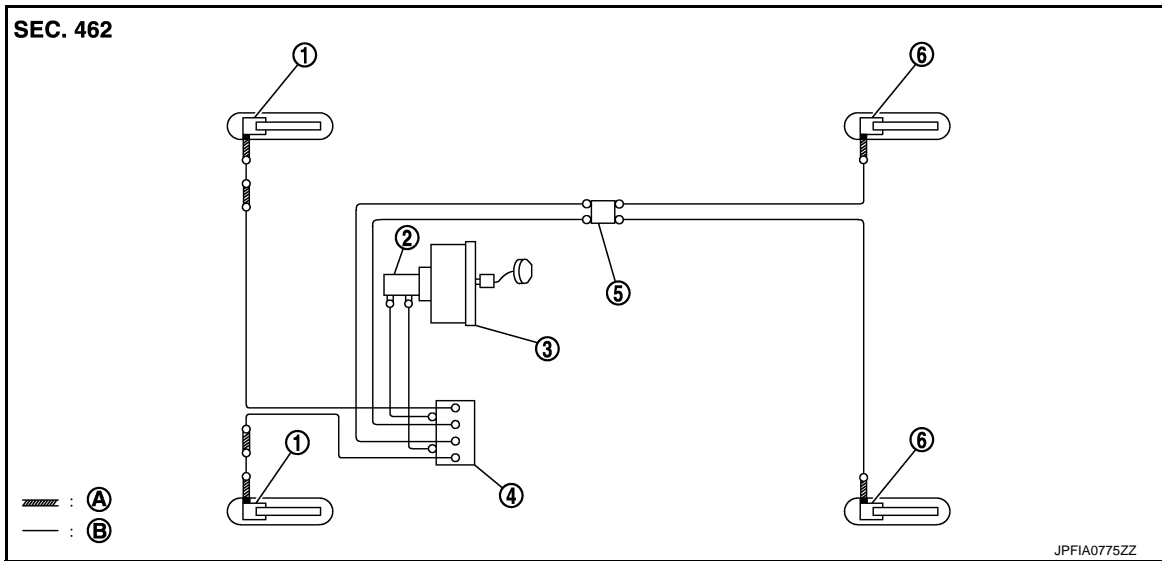

### 4 PISTON TYPE

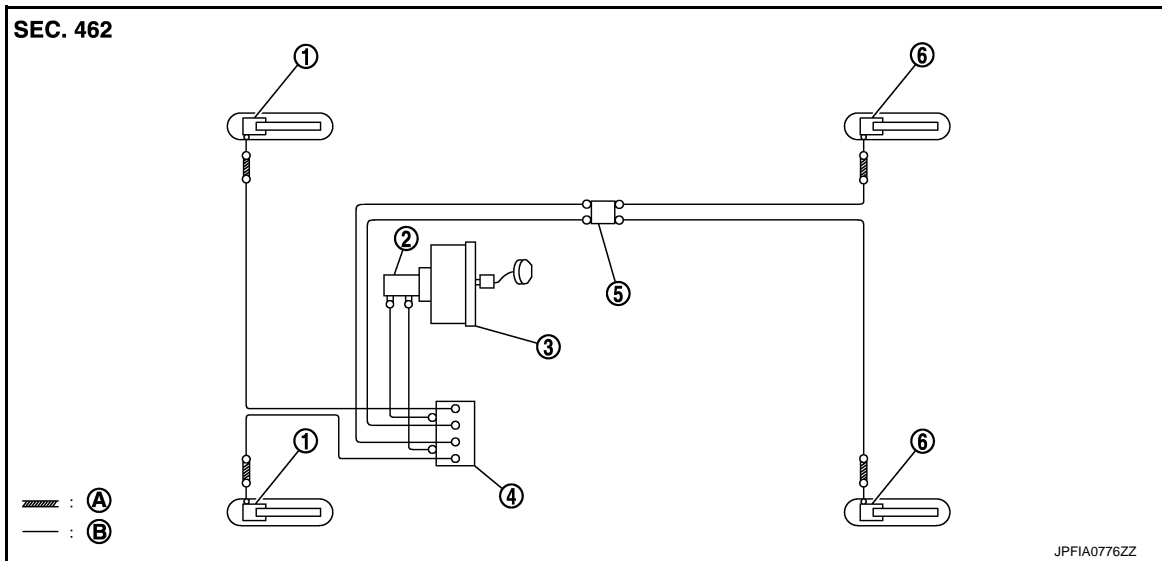

## FRONT : Removal and Installation

INFOID:00000006038200

### REMOVAL

#### 2 Piston Type



# BRAKE PIPING

## < REMOVAL AND INSTALLATION >

### CAUTION:

- **Never spill or splash brake fluid on painted surfaces. Brake fluid may seriously damage paint. Wipe it off immediately and wash with water if it gets on a painted surface.**
- **Never depress the brake pedal. Brake fluid may splash while removing the brake hose or brake tube.**
- **If the brake fluid adheres to the brake caliper assembly and disc rotor, quickly wipe it off.**

1. Remove tires with power tool.
2. Drain brake fluid. Refer to [BR-10. "Draining"](#).
3. Loosen the flare nut with a flare nut wrench and separate the brake tube from the brake hose, and remove the brake tube.

### CAUTION:

- **Never scratch the flare nut and the brake tube.**
  - **Never bend sharply, twist or strongly pull out the brake hose or brake tube.**
  - **Cover open end of brake hose or brake tube when disconnecting to prevent entrance of dirt.**
4. Remove the union bolt and copper washers, and remove the brake hose from the brake caliper assembly.
  5. Remove the brake hose mounting nut.
  6. Remove the lock plate and remove the brake hose.
  7. Remove the brake hose bracket.

#### 4 Piston Type

### CAUTION:

- **Never spill or splash brake fluid on painted surfaces. Brake fluid may seriously damage paint. Wipe it off immediately and wash with water if it gets on a painted surface.**
- **Never depress the brake pedal. Brake fluid may splash while removing the brake hose or brake tube.**
- **Cover crowfoot and flare nut wrench with a cloth as not to damage the brake caliper assembly.**
- **If the brake fluid adheres to the brake caliper assembly and disc rotor, quickly wipe it off.**

1. Remove tires with power tool.
2. Drain brake fluid. Refer to [BR-10. "Draining"](#).
3. Loosen the flare nut with a flare nut wrench and separate the brake tube from the brake hose and caliper.

### CAUTION:

- **Never scratch the flare nut and the brake tube.**
  - **Never bend sharply, twist or strongly pull out the brake hose or brake tube.**
  - **Cover open end of brake hose or brake tube when disconnecting to prevent entrance of dirt.**
4. Remove the brake tube mounting bolt and remove the brake tube.
  5. Remove the brake hose mounting nut.
  6. Remove the lock plate and remove the brake hose.
  7. Remove the brake hose bracket.

## INSTALLATION

#### 2 Piston Type

### CAUTION:

- **Never spill or splash brake fluid on painted surfaces. Brake fluid may seriously damage paint. Wipe it off immediately and wash with water if it gets on a painted surface.**
- **Never depress the brake pedal. Brake fluid may splash while removing the brake hose or brake tube.**
- **If the brake fluid adheres to the brake caliper assembly and disc rotor, quickly wipe it off.**

1. Install the brake hose bracket.
2. Assemble the union bolt and the copper washer to the brake hose.

### CAUTION:

**Never reuse the copper washer.**

A  
B  
C  
D  
E  
BR  
G  
H  
I  
J  
K  
L  
M  
N  
O  
P

# BRAKE PIPING

## < REMOVAL AND INSTALLATION >

3. Align the brake hose pin to the projection (A) of the brake caliper assembly and tighten the union bolt (1) to the specified torque.
4. Install the brake tube to the brake hose, temporarily tighten the flare nut by hand until it does not rotate further, and fix the brake hose to the bracket with the lock plate.

**CAUTION:**

**Check that all brake hose or brake tube are not twisted and bent.**

5. Tighten the flare nut to the specified torque with a flare nut crowfoot and a torque wrench.

**CAUTION:**

**Never scratch the flare nut and the brake tube.**

6. Tighten the brake hose mounting nuts to the specified torque.

**CAUTION:**

**Never reuse the brake hose mounting nuts.**

7. Refill with new brake fluid and perform the air bleeding. Refer to [BR-11. "Bleeding Brake System"](#).
8. Install tires with power tool.
9. Perform inspection after installation. Refer to [BR-26. "FRONT : Inspection"](#).

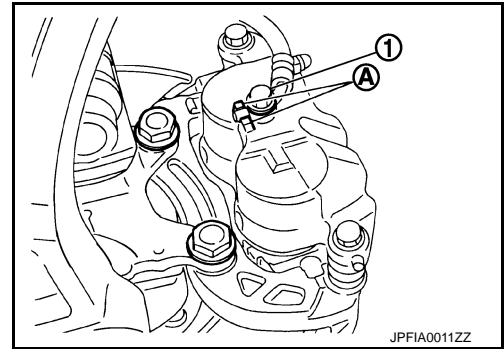

### 4 Piston Type

**CAUTION:**

- **Never spill or splash brake fluid on painted surfaces. Brake fluid may seriously damage paint. Wipe it off immediately and wash with water if it gets on a painted surface.**
- **Never depress the brake pedal. Brake fluid may splash while removing the brake hose or brake tube.**
- **Cover crowfoot and flare nut wrench with a cloth as not to damage the brake caliper assembly.**
- **If the brake fluid adheres to the brake caliper assembly and disc rotor, quickly wipe it off.**

1. Install the brake hose bracket.
2. Install the brake tube to the brake hose and caliper, temporarily tighten the flare nut by hand until it does not rotate further, and fix the brake hose to the bracket with the lock plate.

**CAUTION:**

**Check that all brake hose or brake tube are not twisted and bent.**

3. Tighten the brake hose mounting nuts to the specified torque.

**CAUTION:**

**Never reuse the brake hose mounting nuts.**

4. Tighten the brake tube mounting bolt to the specified torque.
5. Tighten the flare nut to the specified torque with a flare nut crowfoot and a torque wrench.

**CAUTION:**

**Never scratch the flare nut and the brake tube.**

6. Refill with new brake fluid and perform the air bleeding. Refer to [BR-11. "Bleeding Brake System"](#).
7. Install tires with power tool.
8. Perform inspection after installation. Refer to [BR-26. "FRONT : Inspection"](#).

## FRONT : Inspection

INFOID:000000006038201

## INSPECTION AFTER INSTALLATION

1. Check the brake hoses and tubes for the following: no scratches; no twist and deformation; no interference with other components when steering the steering wheel; no looseness at connections.
2. Depress the brake pedal with a force of 785 N (80 kg, 176 lb) and hold down the pedal for approx. 5 seconds with the engine running. Check for any fluid leakage.

**CAUTION:**

**Retighten the applicable connection to the specified torque and repair any abnormal (damaged, worn or deformed) part if any brake fluid leakage is present.**

## REAR

### REAR : Exploded View

INFOID:000000006038202

### 1 PISTON TYPE

# BRAKE PIPING

< REMOVAL AND INSTALLATION >

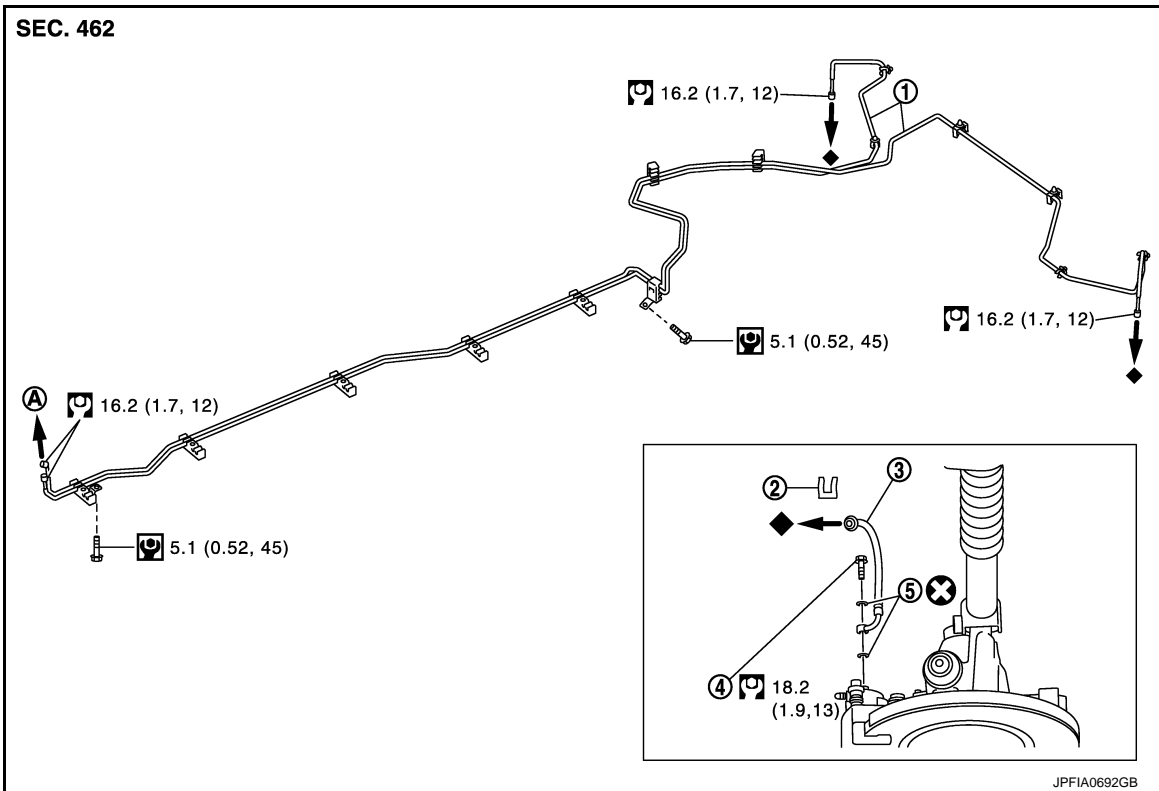

- |               |                  |               |
|---------------|------------------|---------------|
| 1. Brake tube | 2. Lock plate    | 3. Brake hose |
| 4. Union bolt | 5. Copper washer |               |
- A. To connector

Refer to [GI-4, "Components"](#) for symbols in the figure.

## 2 PISTON TYPE

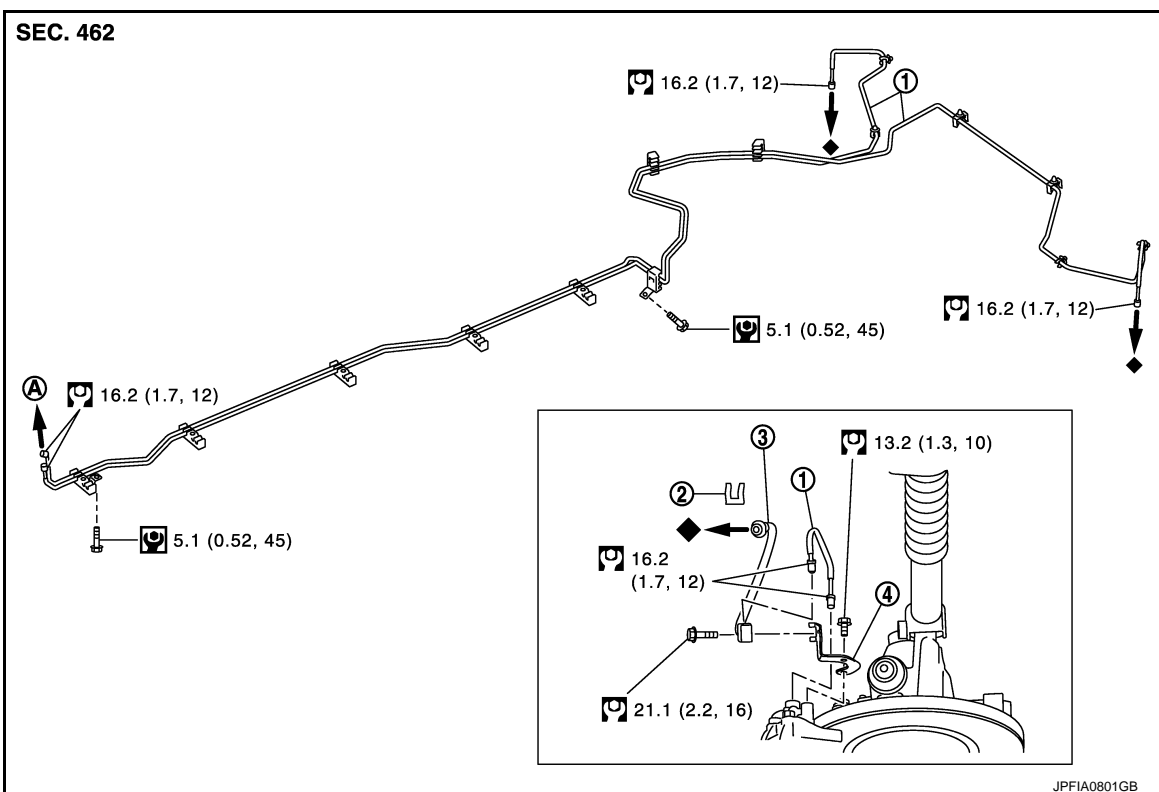

A  
B  
C  
D  
E  
BR  
G  
H  
I  
J  
K  
L  
M  
N  
O  
P

# BRAKE PIPING

## < REMOVAL AND INSTALLATION >

1. Brake tube
2. Lock plate
3. Brake hose
4. Brake hose bracket
- A. To connector

Refer to [GI-4, "Components"](#) for symbols in the figure.

### REAR : Hydraulic Piping

INFOID:000000006038203

#### 2 PISTON TYPE

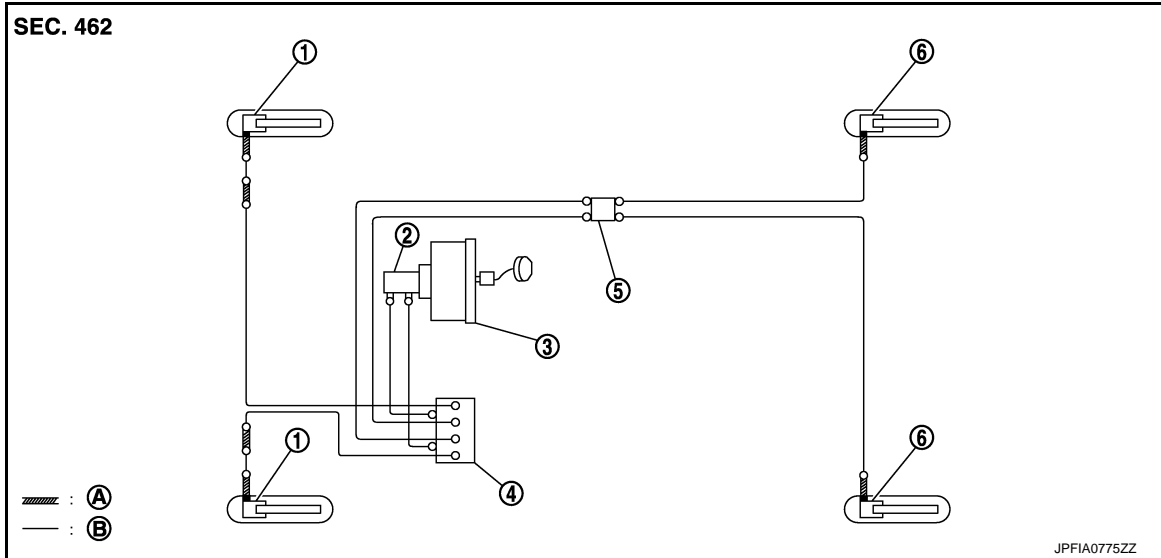

1. Front disc brake
  2. Master cylinder assembly
  3. Brake booster
  4. ABS actuator and electric unit (control unit)
  5. Connector
  6. Rear disc brake
- A. Brake hose  
 B. Brake tube

#### 4 PISTON TYPE

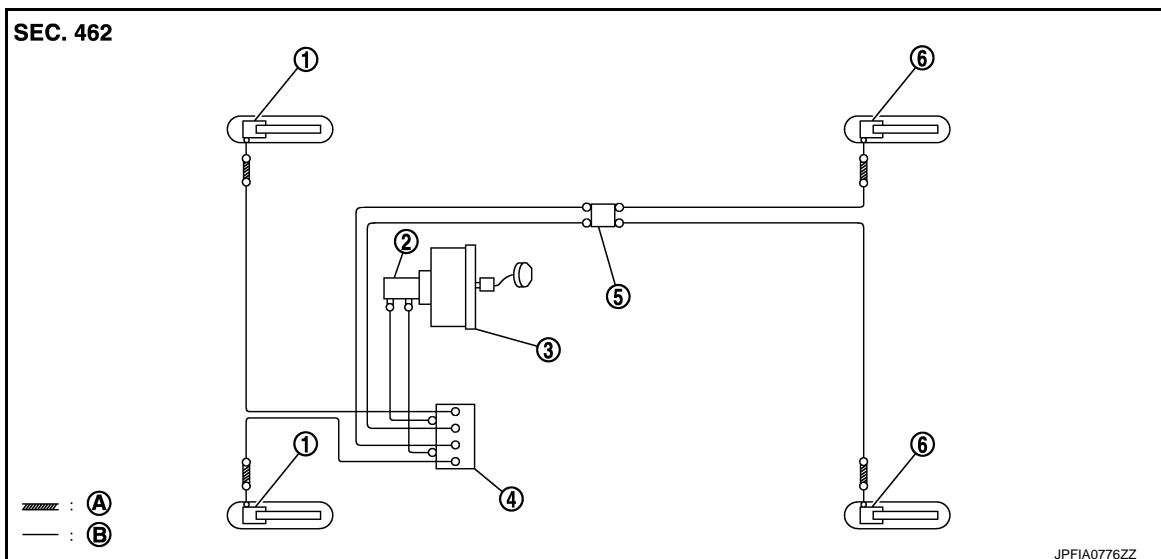

# BRAKE PIPING

## < REMOVAL AND INSTALLATION >

- |  |                             |                    |   |
|--|-----------------------------|--------------------|---|
| 1. Front disc brake                              | 2. Master cylinder assembly | 3. Brake booster   | A |
| 4. ABS actuator and electric unit (control unit) | 5. Connector                | 6. Rear disc brake | B |
| A. Brake hose                                    | B. Brake tube               |                    | C |
- : Flare nut

## REAR : Removal and Installation

INFOID:000000006038204

### REMOVAL

#### 1 Piston Type

##### **CAUTION:**

- Never spill or splash brake fluid on painted surfaces. Brake fluid may seriously damage paint. Wipe it off immediately and wash with water if it gets on a painted surface.
- Never depress the brake pedal. Brake fluid may splash while removing the brake hose or brake tube.
- If the brake fluid adheres to the brake caliper assembly and disc rotor, quickly wipe it off.

1. Remove tires with power tool.
2. Drain brake fluid. Refer to [BR-10, "Draining"](#).
3. Loosen the flare nut with a flare nut wrench and separate the brake tube from the hose, and remove the brake tube.

##### **CAUTION:**

- Never scratch the flare nut and the brake tube.
- Never bend sharply, twist or strongly pull out the brake hose or brake tube.
- Cover open end of brake hose or brake tube when disconnecting to prevent entrance of dirt.

4. Remove the union bolt and copper washers, and remove the brake hose from the brake caliper assembly.
5. Remove the lock plate and remove the brake hose.

#### 2 Piston Type

##### **CAUTION:**

- Never spill or splash brake fluid on painted surfaces. Brake fluid may seriously damage paint. Wipe it off immediately and wash with water if it gets on a painted surface.
- Never depress the brake pedal. Brake fluid may splash while removing the brake hose or brake tube.
- Cover crowfoot and flare nut wrench with a cloth as not to damage the brake caliper assembly.
- If the brake fluid adheres to the brake caliper assembly and disc rotor, quickly wipe it off.

1. Remove tires with power tool.
2. Drain brake fluid. Refer to [BR-10, "Draining"](#).
3. Loosen the flare nut with a flare nut wrench and separate the brake tube from the brake hose and caliper.

##### **CAUTION:**

- Never scratch the flare nut and the brake tube.
- Never bend sharply, twist or strongly pull out the brake hoses and tubes.
- Cover open end of brake hose or brake tube when disconnecting to prevent entrance of dirt.

4. Remove the brake hose mounting bolt.
5. Remove the lock plate and remove the brake hose.
6. Remove the brake hose bracket.

### INSTALLATION

#### 1 Piston Type

##### **CAUTION:**

- Never spill or splash brake fluid on painted surfaces. Brake fluid may seriously damage paint. Wipe it off immediately and wash with water if it gets on a painted surface.
- Never depress the brake pedal. Brake fluid may splash while removing the brake hose or brake tube.
- If the brake fluid adheres to the brake caliper assembly and disc rotor, quickly wipe it off.

1. Assemble the union bolt and the copper washer to the brake hose.

##### **CAUTION:**

- Never reuse the copper washer.

# BRAKE PIPING

## < REMOVAL AND INSTALLATION >

2. Install the brake hose L-pin by aligning it with the brake caliper assembly positioning hole, and tighten the union bolt (1) to the specified torque.

3. Install the brake tube to the brake hose, temporarily tighten the flare nut by hand until it does not rotate further, and fix the brake hose to the bracket with the lock plate.

**CAUTION:**

**Check that all brake hose or brake tube are not twisted and bent.**

4. Tighten the flare nut to the specified torque with a flare nut crowfoot and a torque wrench.

**CAUTION:**

**Never scratch the flare nut and the brake tube.**

5. Refill with new brake fluid and perform the air bleeding. Refer to [BR-11, "Bleeding Brake System"](#).

6. Install tires with power tool.

7. Perform inspection after installation. Refer to [BR-30, "REAR : Inspection"](#).

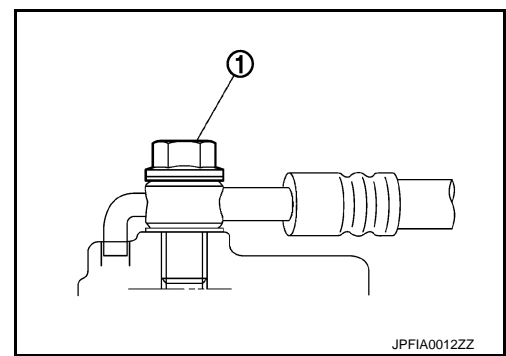

### 2 Piston Type

**CAUTION:**

- **Never spill or splash brake fluid on painted surfaces. Brake fluid may seriously damage paint. Wipe it off immediately and wash with water if it gets on a painted surface.**
- **Never depress the brake pedal. Brake fluid may splash while removing the brake hose or brake tube.**
- **Cover crowfoot and flare nut wrench with a cloth as not to damage the brake caliper assembly.**
- **If the brake fluid adheres to the brake caliper assembly and disc rotor, quickly wipe it off.**

1. Install the brake hose bracket.

2. Install the brake tube to the brake hose and caliper, temporarily tighten the flare nut by hand until it does not rotate further, and fix the brake hose to the bracket with the lock plate.

**CAUTION:**

**Check that all brake hose or brake tube are not twisted and bent.**

3. Tighten the brake hose mounting bolt to the specified torque.

4. Tighten the flare nut to the specified torque with a flare nut crowfoot and a torque wrench.

**CAUTION:**

**Never scratch the flare nut and the brake tube.**

5. Refill with new brake fluid and perform the air bleeding. Refer to [BR-11, "Bleeding Brake System"](#).

6. Install tires with power tool.

7. Perform inspection after installation. Refer to [BR-30, "REAR : Inspection"](#).

## REAR : Inspection

INFOID:000000006038205

### INSPECTION AFTER INSTALLATION

1. Check the brake hoses and tubes for the following: no scratches; no twist and deformation; no interference with other components when steering the steering wheel; no looseness at connections.

2. Depress the brake pedal with a force of 785 N (80 kg, 176 lb) and hold down the pedal for approx. 5 seconds with the engine running. Check for any fluid leakage.

**CAUTION:**

**Retighten the applicable connection to the specified torque and repair any abnormal (damaged, worn or deformed) part if any brake fluid leakage is present.**

# BRAKE MASTER CYLINDER

< REMOVAL AND INSTALLATION >

## BRAKE MASTER CYLINDER

Exploded View

INFOID:000000006038206

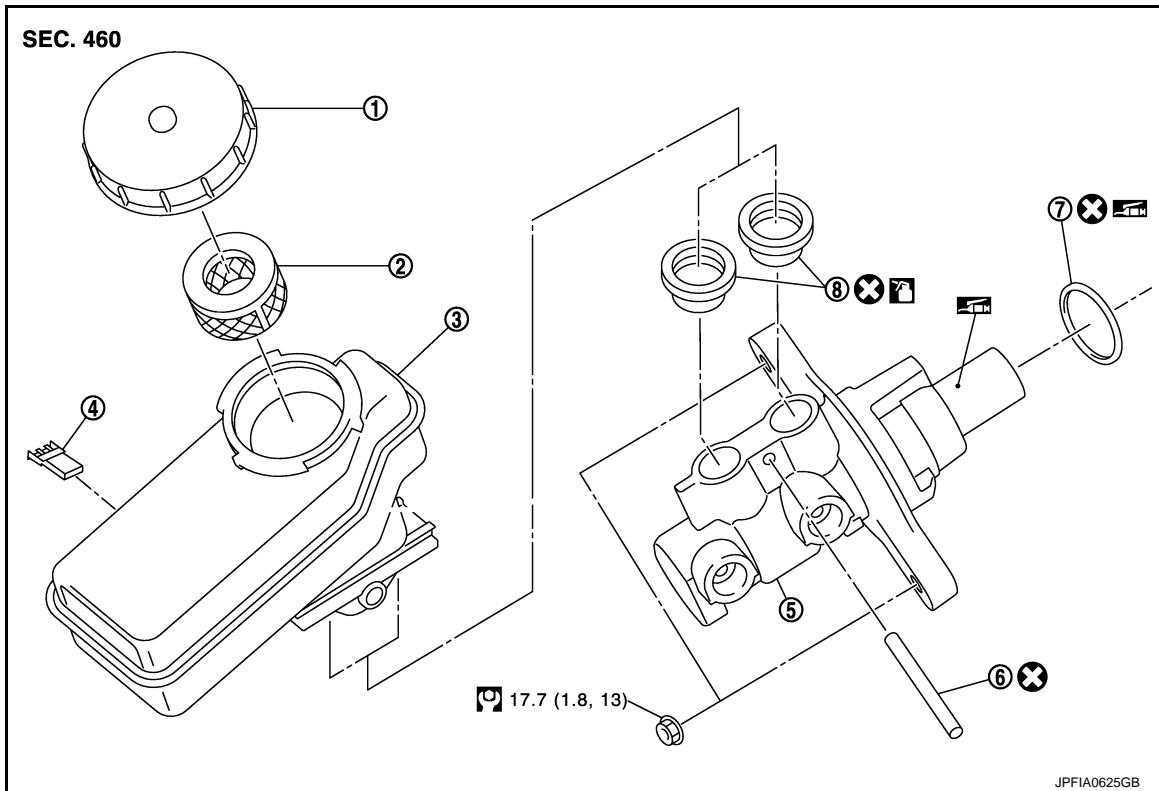

- |                                       |                  |                   |
|---------------------------------------|------------------|-------------------|
| 1. Reservoir cap                      | 2. Oil strainer  | 3. Reservoir tank |
| 4. Brake fluid level switch connector | 5. Cylinder body | 6. Pin            |
| 7. O-ring                             | 8. Grommet       |                   |

: Apply silicone grease.

: Apply brake fluid.

Refer to [GI-4, "Components"](#) for symbols not described on the above.

## Removal and Installation

INFOID:000000006038207

### REMOVAL

#### CAUTION:

- Never spill or splash brake fluid on painted surfaces. Brake fluid may seriously damage paint. Wipe it off immediately and wash with water if it gets on a painted surface.
- Depress the brake pedal several times to release the vacuum pressure from the brake booster. Then remove the master cylinder assembly.
- Never depress the brake pedal. Brake fluid may splash while removing the brake tube.

1. Perform inspection before removal. Refer to [BR-33, "Inspection"](#).
2. Remove the brake master cylinder cover and hoodledge cover LH. Refer to [EXT-21, "Removal and Installation"](#).
3. Drain brake fluid. Refer to [BR-10, "Draining"](#).
4. Disconnect the brake fluid level switch harness connector.
5. Remove the brake tube from between ABS actuator and electric unit (control unit) and master cylinder assembly with a flare nut wrench. Refer to [BR-20, "FRONT : Exploded View"](#).

#### CAUTION:

Never scratch the flare nut and the brake tube.

6. Remove the master cylinder assembly from brake booster.



# BRAKE MASTER CYLINDER

## < REMOVAL AND INSTALLATION >

### CAUTION:

- Never depress the brake pedal after the master cylinder assembly is removed.
- The piston of the master cylinder assembly is exposed. Never damage it when removing the master cylinder.
- The piston may drop off when pulled out strongly. Never hold the piston. Hold the cylinder body when handling the master cylinder assembly.

7. Remove the O-ring.

## INSTALLATION

Note the following, and install in the reverse order of removal.

- Never spill or splash brake fluid on painted surfaces. Brake fluid may seriously damage paint. Wipe it off immediately and wash with water if it gets on a painted surface.
- Never depress the brake pedal. Brake fluid may splash while removing the brake tube.
- Never depress the brake pedal after the master cylinder assembly is removed.
- Apply silicone grease to the brake booster [see (A) in the figure] when installing the master cylinder assembly to the brake booster.
- The piston of the master cylinder assembly is exposed. Never damage it when removing the master cylinder.
- Check that no dirt and dust are present on the piston before installation. Clean it with new brake fluid if necessary.
- The piston may drop off when pulled out strongly. Never hold the piston. Hold the cylinder body when handling the master cylinder assembly.
- Never reuse the O-ring.
- Temporarily tighten the brake tube flare nut to the master cylinder assembly by hand. Then tighten it to the specified torque with a flare nut crowfoot and torque wrench. Refer to [BR-20, "FRONT : Exploded View"](#).

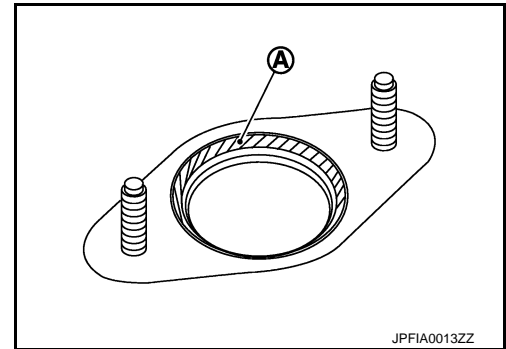

### CAUTION:

**Never scratch the flare nut and the brake tube.**

- Refill with new brake fluid and perform the air bleeding. Refer to [BR-11, "Bleeding Brake System"](#).
- Perform inspection after installation. Refer to [BR-33, "Inspection"](#).

## Disassembly and Assembly

INFOID:000000006038208

## DISASSEMBLY

### CAUTION:

- Never disassemble the cylinder body.
- Remove the reservoir tank only when necessary.

1. Fix the master cylinder assembly to a vise.

### CAUTION:

- Always set copper plates or cloth between vise grips when fixing the cylinder body to a vise.
- Never overtighten the vise.

2. Remove the reservoir tank mounting pin with a pin punch [4 mm (0.157 in)].

3. Remove the reservoir tank and grommet from the cylinder body.

### CAUTION:

**Never drop the removed parts. The parts must not be reused if they are dropped.**

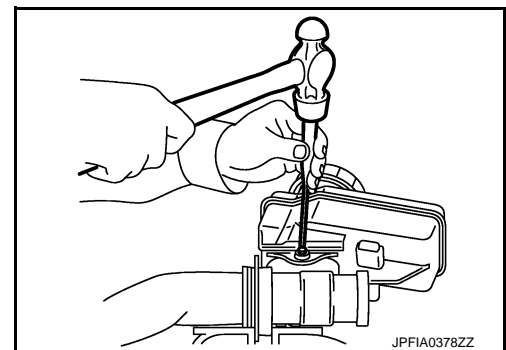

## ASSEMBLY

### CAUTION:

- Never use mineral oils such as kerosene or gasoline and rubber grease during the cleaning and assembly process.
- Never drop the removed parts when installing. The parts must not be reused if they are dropped.
- Never allow foreign matter (e.g. dust) and oils other than brake fluid to enter the reservoir tank.



# BRAKE MASTER CYLINDER

## < REMOVAL AND INSTALLATION >

1. Apply new brake fluid to the grommet and install it to the cylinder body.

**CAUTION:**

**Never reuse the grommets.**

2. Install the reservoir tank to the cylinder body.
3. Fix the master cylinder assembly to a vise.

**CAUTION:**

- Place the reservoir tank with the chamfered pin hole (←) facing up.
- Always set copper plates or cloth between vise grips when fixing the cylinder body to a vise.
- Never overtighten the vise.

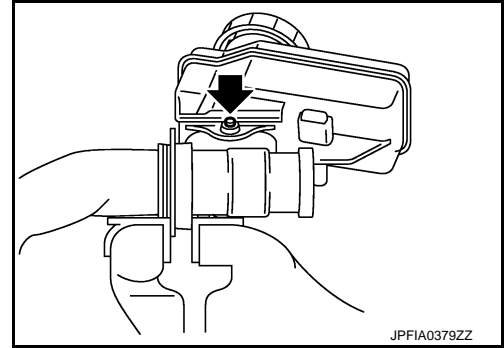

4. Tilt the reservoir tank so that a mounting pin can be inserted. Insert a mounting pin. Return the reservoir tank to the horizontal position. Insert another mounting pin into the pin hole on the opposite side in the same manner after the mounting pin passes through the cylinder body pin hole.

**CAUTION:**

**Never reuse the mounting pin.**

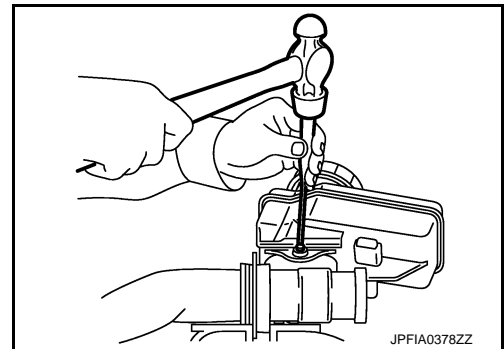

## Inspection

### INSPECTION BEFORE REMOVAL

Check the brake fluid level switch. Refer to [BRC-104, "Component Inspection"](#).

### INSPECTION AFTER INSTALLATION

Check the following items and replace if necessary.

- Check the master cylinder for deformation, twist, contact with other parts or looseness of connection.
- Check for fluid leakage from connection. Refer to [BR-26, "FRONT : Inspection"](#).

**CAUTION:**

**If the fluid leakage is present, retighten to the specified torque. Replace if necessary.**

INFOID:000000006038209

# BRAKE BOOSTER

< REMOVAL AND INSTALLATION >

## BRAKE BOOSTER

Exploded View

INFOID:000000006038210

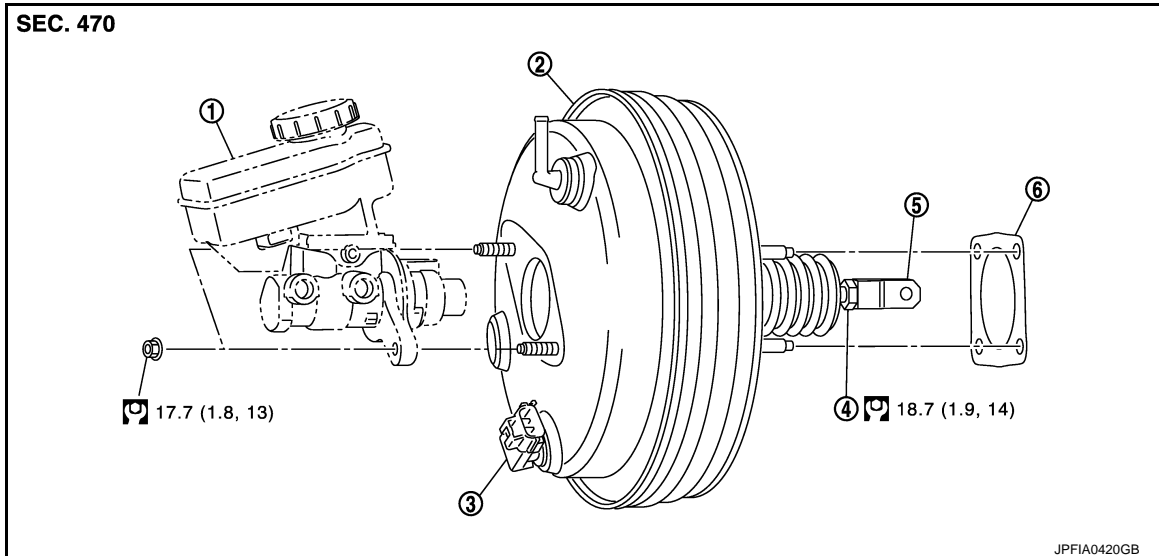

- |                             |                  |                  |
|-----------------------------|------------------|------------------|
| 1. Master cylinder assembly | 2. Brake booster | 3. Vacuum sensor |
| 4. Lock nut                 | 5. Clevis        | 6. Gasket        |

Refer to [GI-4, "Components"](#) for symbols in the figure.

## Removal and Installation

INFOID:000000006038211

### REMOVAL

#### CAUTION:

**Never remove vacuum sensor from brake booster. Replace vacuum sensor and brake booster as a set.**

1. Perform inspection before removal. Refer to [BR-35, "Inspection and Adjustment"](#).
2. Remove the cowl top cover. Refer to [EXT-21, "Removal and Installation"](#).
3. Disconnect the vacuum sensor harness connector.
4. Remove brake master cylinder assembly from brake booster. Refer to [BR-31, "Removal and Installation"](#).
5. Separate vacuum hose from brake booster. Refer to [BR-38, "Removal and Installation"](#).
6. Remove low-pressure flexible hose. Refer to [HA-36, "LOW-PRESSURE FLEXIBLE HOSE : Removal and Installation"](#).
7. Remove high-pressure pipe. Refer to [HA-38, "HIGH-PRESSURE PIPE : Removal and Installation"](#).
8. Remove snap pin (1) and clevis pin (2) from clevis
9. Separate brake tube from ABS actuator and electric unit (control unit) with flare nut wrench. Refer to [BR-20, "FRONT : Exploded View"](#).
10. Remove nuts on brake booster and brake pedal assembly. Refer to [BR-18, "Exploded View"](#).

#### CAUTION:

**Hold the brake booster so as to avoid dropping out.**

11. Remove the brake booster.

#### CAUTION:

**Never deform or bend the brake tubes.**

#### NOTE:

If removing brake booster is difficult, remove clevis from brake booster.

12. Perform adjustment after removal. Refer to [BR-35, "Inspection and Adjustment"](#).

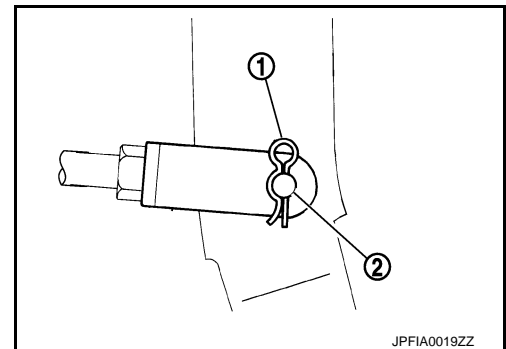

### INSTALLATION

# BRAKE BOOSTER

## < REMOVAL AND INSTALLATION >

Note the following, and install in the reverse order of removal.

- Be careful not to damage brake booster stud bolt threads. If brake booster is tilted during installation, the dash panel may damage the threads.
- Never deform or bend the brake tubes when installing the brake booster.
- Always use a gasket between the brake booster and the dash panel.
- Replace the clevis pin if it is damaged. Refer to [BR-19, "Inspection and Adjustment"](#).
- Install the brake pedal assembly and brake booster mounting nuts, and tighten it to the specified torque. Refer to [BR-18, "Exploded View"](#).
- After installation, perform the air bleeding. Refer to [BR-11, "Bleeding Brake System"](#).
- Perform inspection after installation. Refer to [BR-35, "Inspection and Adjustment"](#).

## Inspection and Adjustment

INFOID:000000006038212

### INSPECTION BEFORE REMOVAL

Air Tight

#### **CAUTION:**

**Check the air tight condition when the master cylinder and the brake booster is installed.**

1. With a handy vacuum pump, apply vacuum pressure of  $-66.7$  kPa ( $-500$  mmHg,  $-19.70$  inHg) to the brake booster.
2. If the air tight condition cannot be maintained, perform the following operation.
  - a. Check the no dirt and dust are present on the brake booster and brake master cylinder matching faces. Clean it if necessary.
  - b. Check O-ring on the master cylinder. If anything is found, replace the O-ring. Refer to [BR-31, "Removal and Installation"](#).
  - c. Check the air tight condition again. If the condition still cannot be maintained, replace the brake booster.

### ADJUSTMENT AFTER REMOVAL

Input Rod Length adjustment

1. Loosen the lock nut (1) and adjust the input rod (2) to the specified length (A).

**A** : [BR-64, "Brake Booster"](#).

2. Tighten the lock nut to the specified torque.

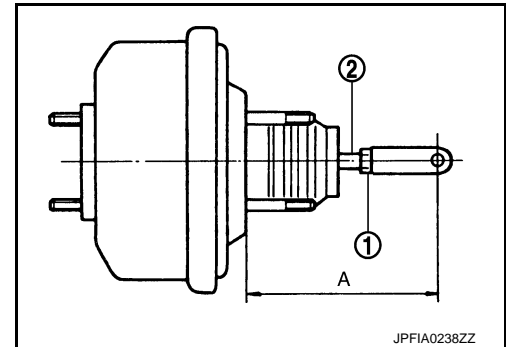

### INSPECTION AFTER INSTALLATION

Operation

Depress the brake pedal several times at 5-second intervals with the engine stopped. Start the engine with the brake pedal fully depressed. Check that the clearance between brake pedal and dash lower panel decreases.

#### **NOTE:**

A slight impact with a small click may be felt on the pedal when the brake pedal is fully depressed. This is a normal phenomenon due to the brake system operation.

Air Tight

1. Run the engine for 1 minute to apply vacuum to the brake booster, and stop the engine. Then depress the brake pedal several times at 5-second intervals until the accumulated vacuum is released to atmospheric pressure. Check that the clearance between brake pedal and dash lower panel gradually increases each time the brake pedal is depressed when performing this operation.
2. Depress the brake pedal with the engine running. Then stop the engine while holding down the brake pedal. Check that the brake pedal stroke does not change after holding down the brake pedal for 30 seconds or more.

#### **NOTE:**

## BRAKE BOOSTER

### < REMOVAL AND INSTALLATION >

---

A slight impact with a small click may be felt on the pedal when the brake pedal is fully depressed. This is a normal phenomenon due to the brake system operation.

#### Brake Pedal

Perform the brake pedal adjustment after installing the brake pedal assembly. Refer to [BR-7. "Inspection and Adjustment"](#).

# VACUUM LINES

< REMOVAL AND INSTALLATION >

## VACUUM LINES

Exploded View

INFOID:000000006038213

VQ37VHR

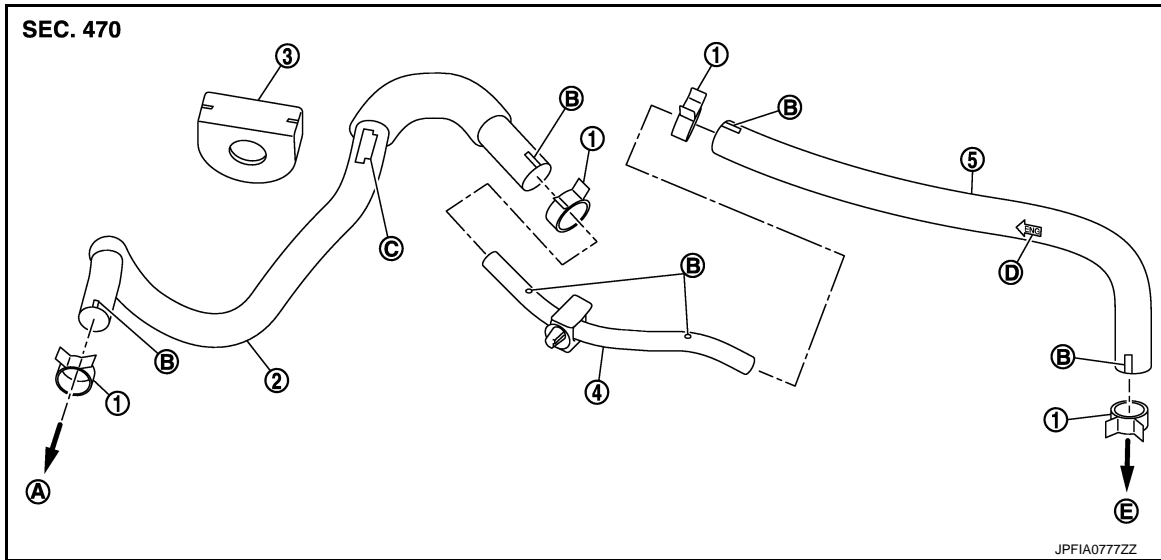

- |                       |                                       |   |
|-----------------------|---------------------------------------|---|
| 1. Clamp              | 2. Vacuum hose                        | 3. Grommet  |
| 4. Vacuum piping      | 5. Vacuum hose (built-in check valve) | C. Stamp indicating grommet installation position |
| A. To intake manifold | B. Paint mark                         | D. Stamp indicating engine direction              |
|                       | E. To brake booster                   |   |

VK56VD

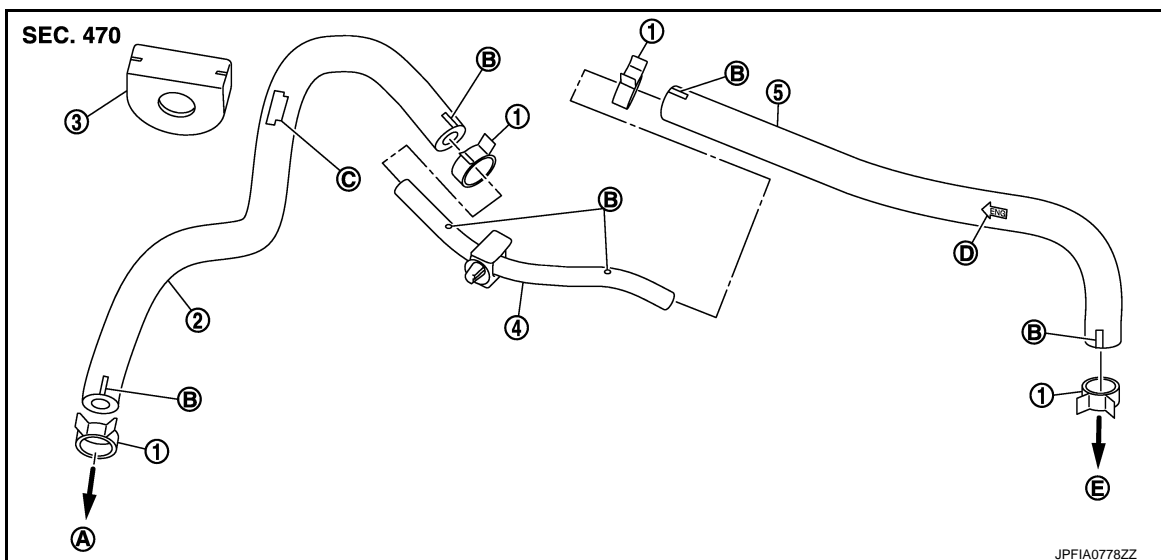

- |                       |                                       |   |
|-----------------------|---------------------------------------|---|
| 1. Clamp              | 2. Vacuum hose                        | 3. Grommet  |
| 4. Vacuum piping      | 5. Vacuum hose (built-in check valve) | C. Stamp indicating grommet installation position |
| A. To intake manifold | B. Paint mark                         | D. Stamp indicating engine direction              |
|                       | E. To brake booster                   |   |

# VACUUM LINES

## < REMOVAL AND INSTALLATION >

### Removal and Installation

INFOID:000000006038214

#### REMOVAL

1. Remove the engine cover. Refer to [EM-27. "Removal and Installation"](#) (VQ37VHR), [EM-182. "Removal and Installation"](#) (VK56VD).
2. Remove the brake master cylinder cover and hoodledge cover (LH). Refer to [EXT-21. "Removal and Installation"](#).
3. Remove the grommet.
4. Remove the vacuum hose and vacuum piping.
5. Perform inspection after removal. Refer to [BR-38. "Inspection"](#).

#### INSTALLATION

Note the following, install in the reverse order of removal.

- Because vacuum hose contains a check valve, it must be installed in the correct position. Refer to the stamp to confirm correct installation. Brake booster will not operate normally if the hose is installed in the wrong direction.
- When installing vacuum hose, insert it until its tip reaches the back-end of length (A) or further as shown in the figure.

**A : 24 mm (0.95 in) or more**

- Face the paint marks of vacuum hose (built-in check valve, brake booster side) to the vehicle front side to assemble.
- Face the other paint marks upward to assemble.

#### **CAUTION:**

**Never use lubricating oil during assembly.**

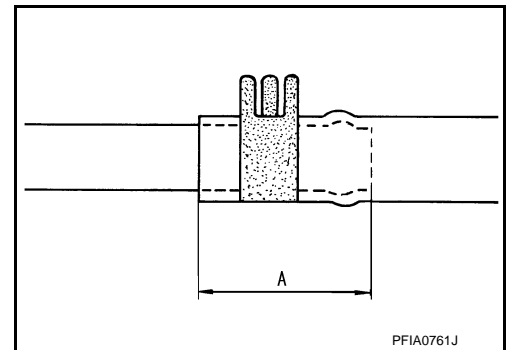

#### Inspection

INFOID:000000006038215

#### INSPECTION AFTER REMOVAL

##### Appearance

Check for correct assembly, damage and deterioration.

##### Check Valve Airtightness

- Use a handy vacuum pump (A) to check.

#### **When connected to the booster side (B):**

**Vacuum should decrease within 1.3 kPa (9.8 mmHg, 0.38 inHg, -0.013 bar) for 15 seconds under a vacuum of -66.7 kPa (-500 mmHg, -19.70 inHg).**

#### **When connected to the engine side (C):**

**Vacuum should not exist.**

- Replace vacuum hose assembly if vacuum hose and check valve are malfunctioning.

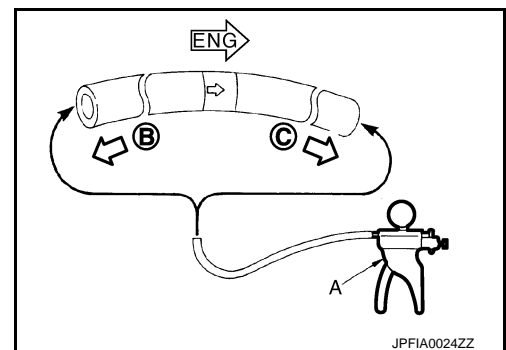

# FRONT DISC BRAKE

< REMOVAL AND INSTALLATION >

## FRONT DISC BRAKE

### BRAKE PAD (2 PISTON TYPE)

### BRAKE PAD (2 PISTON TYPE) : Exploded View

INFOID:000000006038216

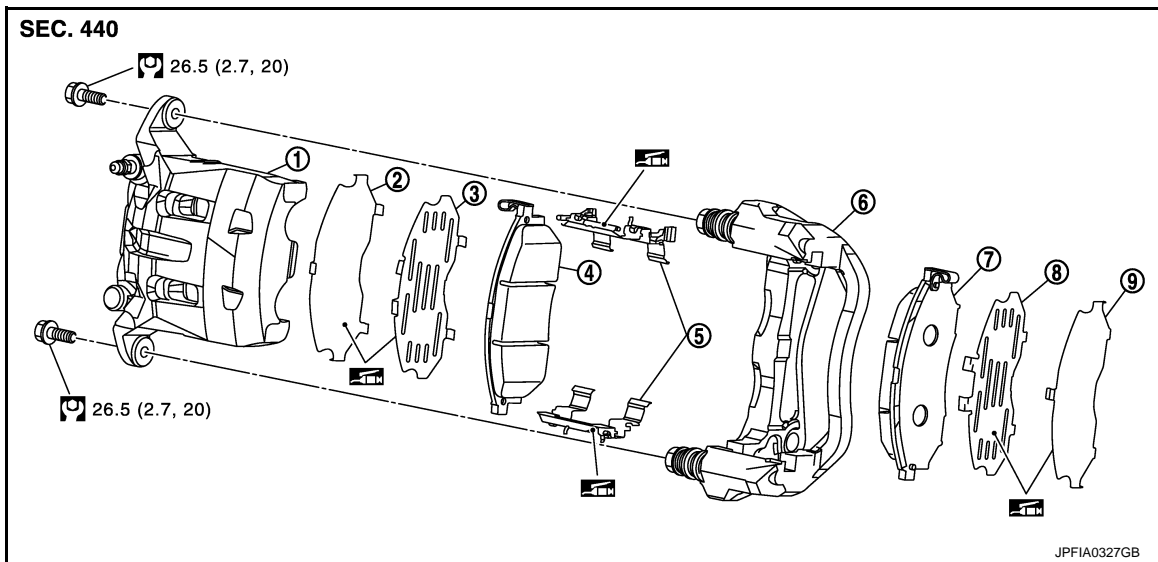

- |                                     |                     |                     |
|-------------------------------------|---------------------|---------------------|
| 1. Cylinder body                    | 2. Inner shim cover | 3. Inner shim       |
| 4. Inner pad (with pad wear sensor) | 5. Pad retainer     | 6. Torque member    |
| 7. Outer pad                        | 8. Outer shim       | 9. Outer shim cover |

: Apply copper based brake grease.

Refer to [GI-4. "Components"](#) for symbols not described on the above.

### BRAKE PAD (2 PISTON TYPE) : Removal and Installation

INFOID:000000006038217

#### REMOVAL

##### **WARNING:**

Clean any dust from the brake caliper and brake pads with a vacuum dust collector. Never blow with compressed air.

##### **CAUTION:**

- Never depress the brake pedal while removing the brake pads because the piston may pop out.
- If the brake fluid or grease adheres to the brake caliper assembly and disc rotor, quickly wipe it off.

1. Remove tires with power tool.
2. Remove lower sliding pin bolt.
3. Suspend the cylinder body with suitable wire so that the brake hose will not stretch. Then remove the brake pads from the torque member.

##### **CAUTION:**

- Never deform the pad retainer when removing the pad retainer from the torque member.
- Never damage the piston boot.
- Never drop the brake pads, shims and shim covers.
- Remember each position of the removed brake pads.

4. Perform inspection after removal. Refer to [BR-40. "BRAKE PAD \(2 PISTON TYPE\) : Inspection"](#).

#### INSTALLATION

##### **WARNING:**

Clean any dust from the brake caliper and brake pads with a vacuum dust collector. Never blow with compressed air.

##### **CAUTION:**

- Never depress the brake pedal while removing the brake pads because the piston may pop out.
- If the brake fluid or grease adheres to the brake caliper assembly and disc rotor, quickly wipe it off.

# FRONT DISC BRAKE

## < REMOVAL AND INSTALLATION >

1. Apply copper based brake grease to the pad retainers before installing it to the torque member if the pad retainers has been removed.

**CAUTION:**

- Securely assemble the pad retainers so that it will not be lifted up from the torque member.
- Never deform the pad retainers.

2. Apply copper based brake grease to the matching faces (A) between the shim and shim cover, and install shim and shim cover to the brake pad.

**CAUTION:**

Always replace the shims and shim covers when replacing the brake pad.

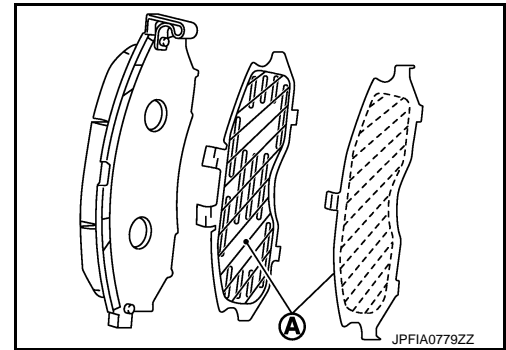

3. Install the brake pads to the torque member.

**CAUTION:**

Both inner and outer pads have a pad return system on the pad retainer. Install pad return lever (1) securely to pad retainer (2).

4. Install cylinder body to torque member.

**CAUTION:**

- Never damage the piston boot.
- When replacing brake pad with new one, check a brake fluid level in the reservoir tank because brake fluid returns to master cylinder reservoir tank when pressing piston in.

**NOTE:**

Use a disc brake piston tool to easily press piston.

5. Install the lower sliding pin bolt and tighten it to the specified torque.
6. Depress the brake pedal several times to check that no drag feel is present for the front disc brake. Refer to [BR-40, "BRAKE PAD \(2 PISTON TYPE\) : Inspection"](#).
7. Install tires with power tool.

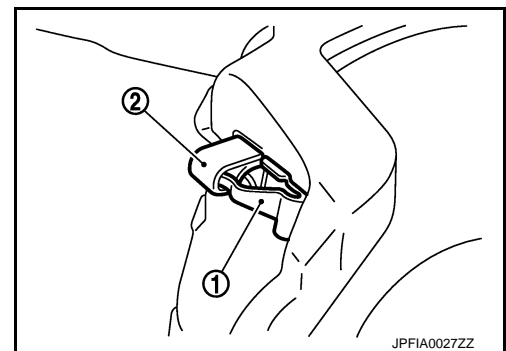

## BRAKE PAD (2 PISTON TYPE) : Inspection

INFOID:00000006038218

### INSPECTION AFTER REMOVAL

- Replace the shims and shim covers if rust is excessively attached.
- Eliminate rust on the pad retainers and the torque member. Replace them if rust is excessively attached.

### INSPECTION AFTER INSTALLATION

1. Check a drag of front disc brake. If any drag is found, follow the procedure described below.
2. Remove brake pads. Refer to [BR-39, "BRAKE PAD \(2 PISTON TYPE\) : Removal and Installation"](#).
3. Press the pistons. Refer to [BR-39, "BRAKE PAD \(2 PISTON TYPE\) : Removal and Installation"](#).
4. Install brake pads. Refer to [BR-39, "BRAKE PAD \(2 PISTON TYPE\) : Removal and Installation"](#).
5. Depress the brake pedal several times.
6. Check a drag of front disc brake again. If any drag is found, disassemble the cylinder body. Refer to [BR-45, "BRAKE CALIPER ASSEMBLY \(2 PISTON TYPE\) : Disassembly and Assembly"](#).
7. Burnish contact surfaces brake pads and disc rotor after refinishing or replacing brake pads, or if a soft pedal occurs at very low mileage. Refer to [BR-14, "BRAKE PAD : Inspection and Adjustment"](#).

## BRAKE PAD (4 PISTON TYPE)



# FRONT DISC BRAKE

< REMOVAL AND INSTALLATION >

## BRAKE PAD (4 PISTON TYPE) : Exploded View

INFOID:000000006038219

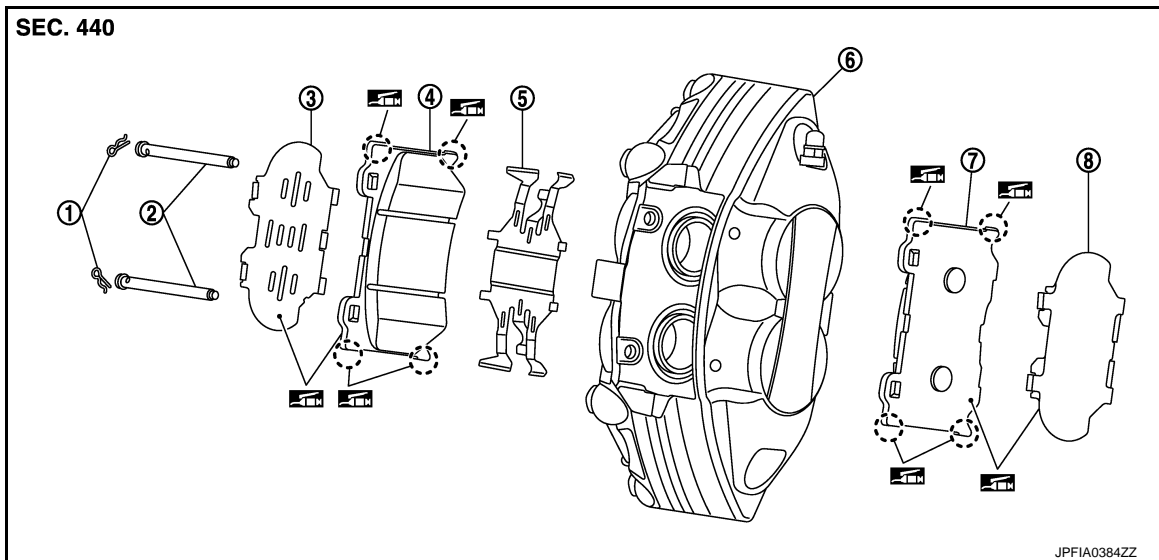

- |                                     |                 |               |
|-------------------------------------|-----------------|---------------|
| 1. Clip                             | 2. Pad pin      | 3. Inner shim |
| 4. Inner pad (with pad wear sensor) | 5. Cross spring | 6. Caliper    |
| 7. Outer pad                        | 8. Outer shim   |               |

Apply copper based brake grease.

Refer to [GI-4, "Components"](#) for symbols not described on the above.

## BRAKE PAD (4 PISTON TYPE) : Removal and Installation

INFOID:000000006038220

### REMOVAL

#### **WARNING:**

Clean any dust from the brake caliper and brake pads with a vacuum dust collector. Never blow with compressed air.

#### **CAUTION:**

- Never depress the brake pedal while removing the brake pads because the piston may pop out.
- If the brake fluid or grease adheres to the brake caliper assembly and disc rotor, quickly wipe it off.

1. Remove tires with power tool.
2. Remove clips (1) from pad pins with suitable pliers.

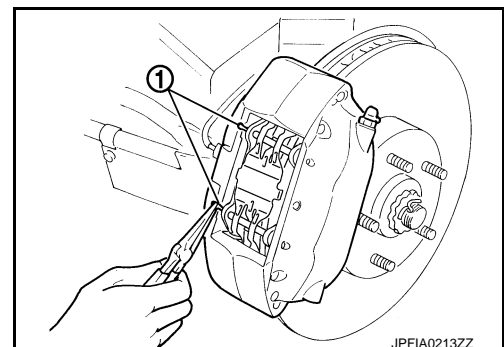

# FRONT DISC BRAKE

## < REMOVAL AND INSTALLATION >

3. Remove pad pins with suitable pliers, while holding down cross spring, then remove cross spring from caliper.

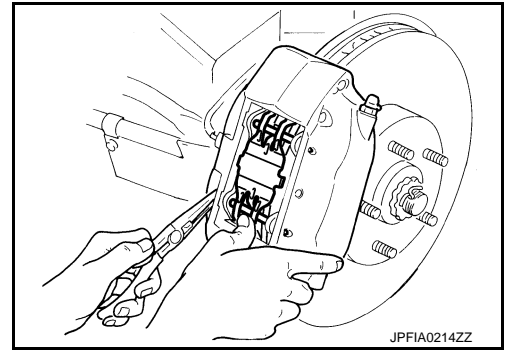

4. Remove brake pads and shims from caliper with suitable pliers.  
**CAUTION:**
  - Never damage the piston boot.
  - Never drop the brake pads and shims.
  - Remember each position of the removed brake pads.
5. Perform inspection after removal. Refer to [BR-43, "BRAKE PAD \(4 PISTON TYPE\) : Inspection"](#).

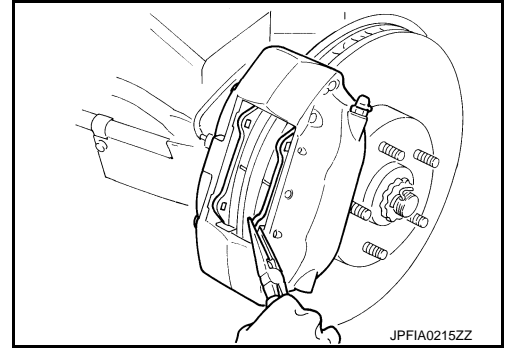

## INSTALLATION

### **WARNING:**

Clean any dust from the brake caliper and brake pads with a vacuum dust collector. Never blow with compressed air.

### **CAUTION:**

- Never depress the brake pedal while removing the brake pads because the piston may pop out.
- If the brake fluid or grease adheres to the brake caliper assembly and disc rotor, quickly wipe it off.

1. Apply copper based brake grease to the matching faces (A) between the brake pad and shim, and install shim to the brake pad.

### **CAUTION:**

Always replace the shims when replacing the brake pad.

2. Apply copper based brake grease to the matching faces (B) between the brake pad and caliper.
3. Install the brake pads to the caliper.

### **CAUTION:**

- Never damage the piston boot.
- When replacing brake pad with new one, check a brake fluid level in the reservoir tank because brake fluid returns to master cylinder reservoir tank when pressing piston in.

### **NOTE:**

Use a disc brake piston tool to easily press piston.

4. Install upper pad pin from the inner side, then install firmly to the outer side through the hole in the top of brake pad.

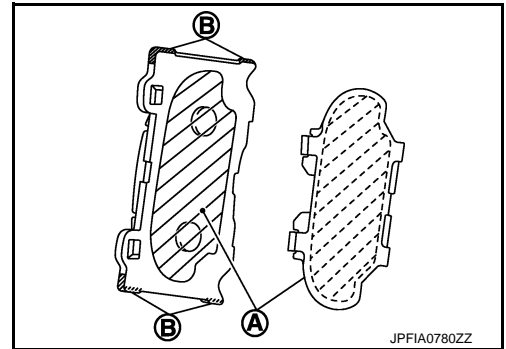

# FRONT DISC BRAKE

## < REMOVAL AND INSTALLATION >

- Place the top of cross spring (1) over the upper pad pin (2), press in the cross spring, install lower pad pin from the inner side to the outer side, and secure cross spring.
- Install clips to the pad pins.  
**CAUTION:**  
**If clip is not fully attached, pad pin or brake pad could fall out while vehicle is in motion.**
- Depress the brake pedal several times to check that no drag feel is present for the front disc brake. Refer to [BR-43, "BRAKE PAD \(4 PISTON TYPE\) : Inspection"](#).
- Install tires with power tool.

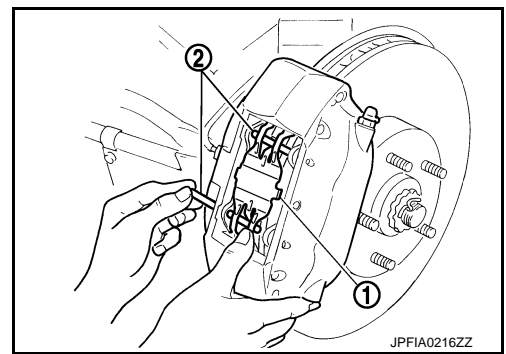

## BRAKE PAD (4 PISTON TYPE) : Inspection

INFOID:000000006038221

### INSPECTION AFTER REMOVAL

Replace the shims if rust is excessively attached.

### INSPECTION AFTER INSTALLATION

- Check a drag of front disc brake. If any drag is found, follow the procedure described below.
- Remove brake pads. Refer to [BR-41, "BRAKE PAD \(4 PISTON TYPE\) : Removal and Installation"](#).
- Press the pistons. Refer to [BR-41, "BRAKE PAD \(4 PISTON TYPE\) : Removal and Installation"](#).
- Install brake pads. Refer to [BR-41, "BRAKE PAD \(4 PISTON TYPE\) : Removal and Installation"](#).
- Depress the brake pedal several times.
- Check a drag of front disc brake again. If any drag is found, disassemble the cylinder body. Refer to [BR-48, "BRAKE CALIPER ASSEMBLY \(4 PISTON TYPE\) : Disassembly and Assembly"](#).
- Burnish contact surfaces brake pads and disc rotor after refinishing or replacing brake pads, or if a soft pedal occurs at very low mileage. Refer to [BR-14, "BRAKE PAD : Inspection and Adjustment"](#).

## BRAKE CALIPER ASSEMBLY (2 PISTON TYPE)

## BRAKE CALIPER ASSEMBLY (2 PISTON TYPE) : Exploded View

INFOID:000000006038222

### REMOVAL

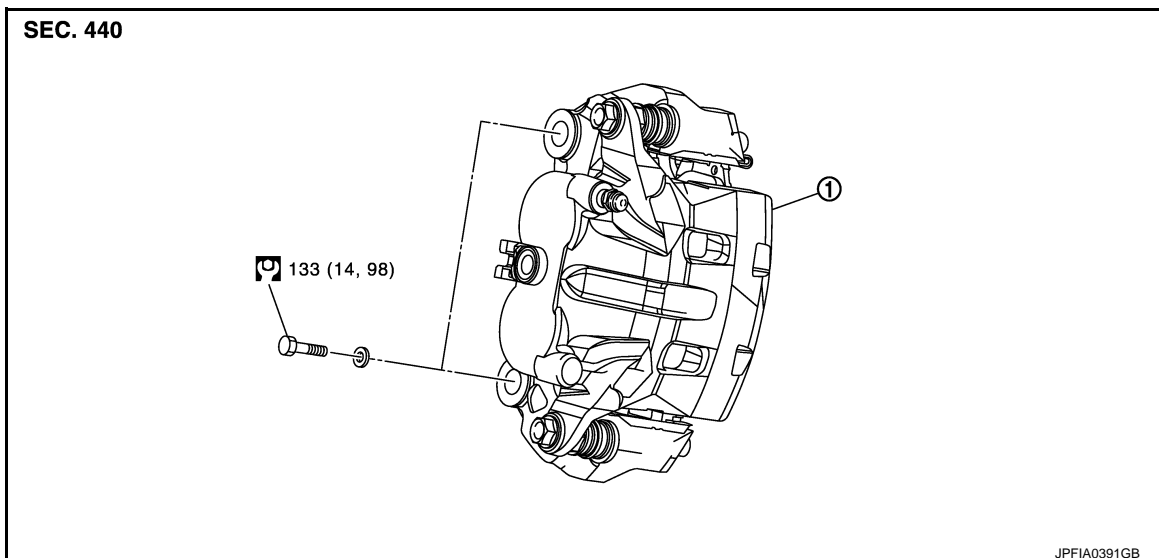

- Brake caliper assembly

Refer to [GI-4, "Components"](#) for symbols in the figure.

### DISASSEMBLY

# FRONT DISC BRAKE

## < REMOVAL AND INSTALLATION >

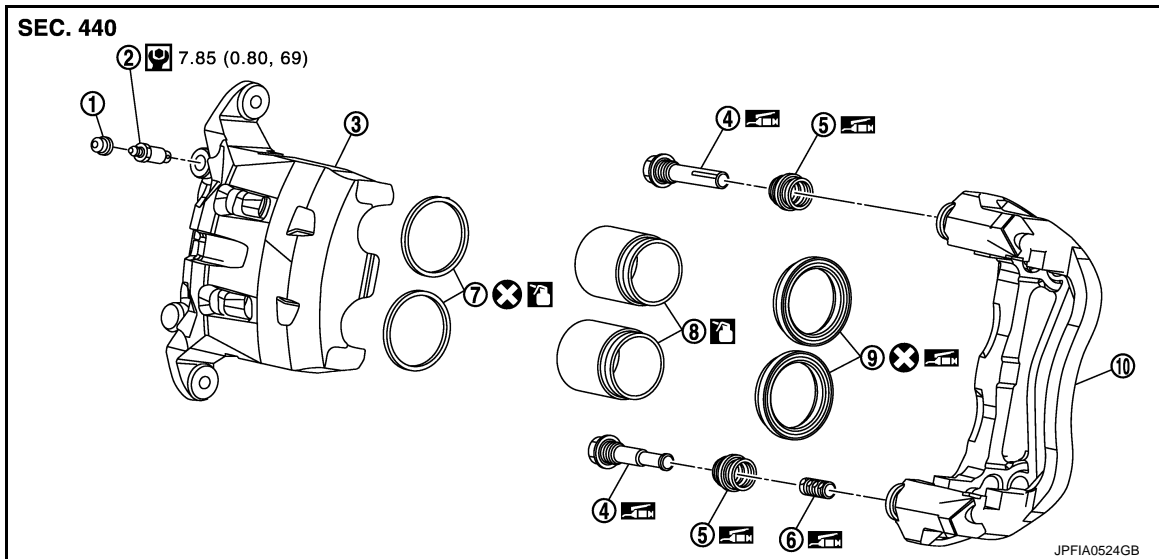

- |                   |                     |                  |
|-------------------|---------------------|------------------|
| 1. Cap            | 2. Bleeder valve    | 3. Cylinder body |
| 4. Sliding pin    | 5. Sliding pin boot | 6. Bushing       |
| 7. Piston seal    | 8. Piston           | 9. Piston boot   |
| 10. Torque member |                     |                  |

Apply rubber grease.

Apply brake fluid.

Refer to [GI-4, "Components"](#) for symbols not described on the above.

## BRAKE CALIPER ASSEMBLY (2 PISTON TYPE) : Removal and Installation

INFOID:000000006038223

### REMOVAL

#### **WARNING:**

**Clean any dust from the brake caliper and brake pads with a vacuum dust collector. Never blow with compressed air.**

#### **CAUTION:**

- Never spill or splash brake fluid on painted surfaces. Brake fluid may seriously damage paint. Wipe it off immediately and wash with water if it gets on a painted surface.
- Never depress the brake pedal while removing the brake pads because the piston may pop out.
- If the brake fluid or grease adheres to the brake caliper assembly and disc rotor, quickly wipe it off.

1. Remove tires with power tool.
2. Fix the disc rotor using wheel nuts.
3. Drain brake fluid. Refer to [BR-10, "Draining"](#).
4. Remove union bolt and copper washer, and separate brake hose from brake caliper assembly. Refer to [BR-24, "FRONT : Removal and Installation"](#).
5. Remove torque member mounting bolts, and remove brake caliper assembly.

#### **CAUTION:**

**Never drop brake pad and brake caliper assembly.**

6. Remove disc rotor. Refer to [FAX-7, "Removal and Installation"](#) (2WD), [FAX-17, "Removal and Installation"](#) (AWD).

### INSTALLATION

#### **WARNING:**

**Clean any dust from the brake caliper and brake pads with a vacuum dust collector. Never blow with compressed air.**

#### **CAUTION:**

# FRONT DISC BRAKE

## < REMOVAL AND INSTALLATION >

- Never spill or splash brake fluid on painted surfaces. Brake fluid may seriously damage paint. Wipe it off immediately and wash with water if it gets on a painted surface.
  - Never depress the brake pedal while removing the brake pads because the piston may pop out.
  - If the brake fluid or grease adheres to the brake caliper assembly and disc rotor, quickly wipe it off.
1. Install disc rotor. Refer to [FAX-7, "Removal and Installation"](#) (2WD), [FAX-17, "Removal and Installation"](#) (AWD).
  2. Install the brake caliper assembly to the steering knuckle and tighten the torque member mounting bolts to the specified torque.  
**CAUTION:**  
Never spill or splash any grease and moisture on the brake caliper assembly mounting face, threads, mounting bolts and washers. Wipe out any grease and moisture.
  3. Install brake hose and copper washers to brake caliper assembly. Refer to [BR-24, "FRONT : Removal and Installation"](#).
  4. Refill with new brake fluid and perform the air bleeding. Refer to [BR-11, "Bleeding Brake System"](#).
  5. Check a drag of front disc brake. If any drag is found, refer to [BR-46, "BRAKE CALIPER ASSEMBLY \(2 PISTON TYPE\) : Inspection"](#).
  6. Install tires with power tool.

## BRAKE CALIPER ASSEMBLY (2 PISTON TYPE) : Disassembly and Assembly

INFOID:000000006038224

### DISASSEMBLY

#### NOTE:

Never remove the torque member, brake pad and pad retainers when disassembling and assembling the cylinder body.

1. Remove the sliding pin bolt, and remove the cylinder body from the torque member.

#### CAUTION:

Fix the brake pad at suitable tape so that the brake pad will not drop.

2. Remove sliding pins and sliding pin boots from torque member.
3. Remove bushing from sliding pin.
4. Place a wooden block as shown in the figure, and blow air from union bolt mounting hole to remove pistons and piston boots.

#### CAUTION:

Never get fingers caught in the pistons.

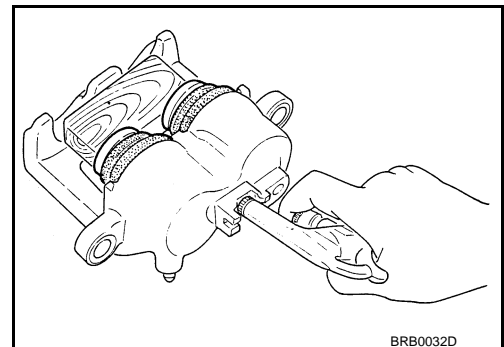

5. Remove piston seals from cylinder body using suitable tool.

#### CAUTION:

Be careful not to damage a cylinder inner wall.

6. Remove bleeder valve and cap.
7. Perform inspection after disassembly. Refer to [BR-46, "BRAKE CALIPER ASSEMBLY \(2 PISTON TYPE\) : Inspection"](#).

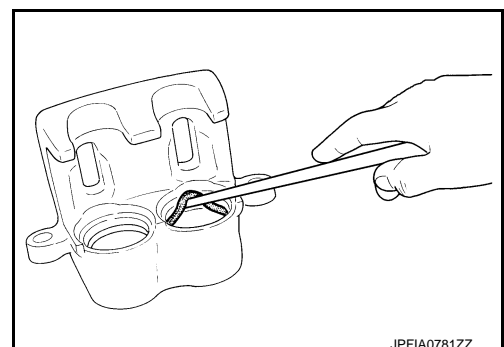

### ASSEMBLY

1. Install bleeder valve and cap.

## FRONT DISC BRAKE

### < REMOVAL AND INSTALLATION >

2. Apply new brake fluid to piston seals (1), and install them to cylinder body.

**CAUTION:**

**Never reuse piston seals.**

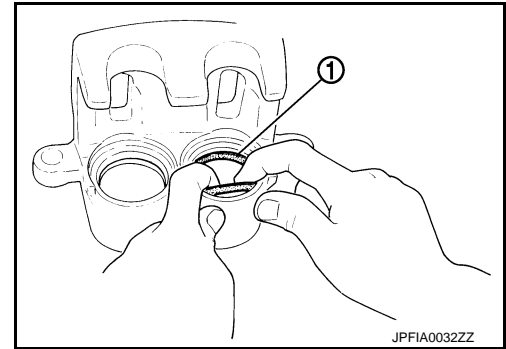

3. Apply rubber grease to piston boots (1). Cover the piston (2) end with piston boot, and then install cylinder side lip on piston boot securely into a groove on cylinder body.

**CAUTION:**

**Never reuse piston boots.**

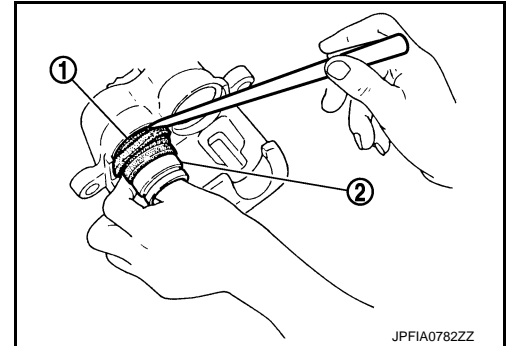

4. apply new brake fluid to pistons (1). Push piston into cylinder body by hand and push piston boot (2) piston-side lip into the piston groove.

**CAUTION:**

**Press the pistons evenly and vary the pressing point to prevent cylinder inner wall from being rubbed.**

5. Apply rubber grease to bushing, and install bushing to sliding pin.
6. Apply rubber grease to sliding pins and sliding pin boots, and install sliding pins and sliding pin boots to torque member.
7. Install the cylinder body to tighten sliding pin bolts to the specified torque.

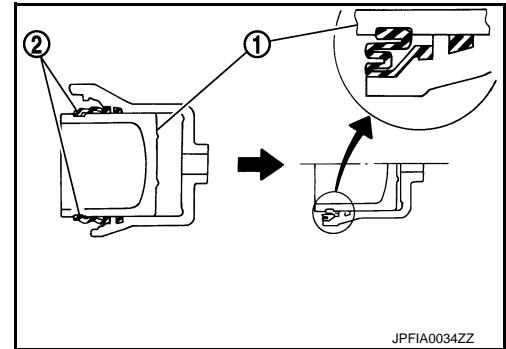

### BRAKE CALIPER ASSEMBLY (2 PISTON TYPE) : Inspection

INFOID:000000006038225

#### INSPECTION AFTER DISASSEMBLY

Check the following items and replace if necessary.

##### Cylinder Body

Check the cylinder inner wall for rust, wear, cracks or damage.

**CAUTION:**

**Always clean with new brake fluid. Never clean with mineral oil such as gasoline and light oil.**

##### Torque Member

Check the torque member for rust, wear, cracks or damage.

##### Pistons

Check the surface of the piston for rust, wear, cracks or damage.

**CAUTION:**

**A piston sliding surface is plated. Never polish with sandpaper.**

##### Sliding Pin, Sliding Pin Boot and Bushing

Check the sliding pins, sliding pin boots and bushing for rust, wear, cracks or damage.

#### INSPECTION AFTER INSTALLATION

1. Check a drag of front disc brake. If any drag is found, follow the procedure described below.
2. Remove brake pads. Refer to [BR-39. "BRAKE PAD \(2 PISTON TYPE\) : Removal and Installation"](#).

# FRONT DISC BRAKE

## < REMOVAL AND INSTALLATION >

3. Press the pistons. Refer to [BR-39, "BRAKE PAD \(2 PISTON TYPE\) : Removal and Installation"](#).
4. Install brake pads. Refer to [BR-39, "BRAKE PAD \(2 PISTON TYPE\) : Removal and Installation"](#).
5. Depress the brake pedal several times.
6. Check a drag of front disc brake again. If any drag is found, disassemble the cylinder body. Refer to [BR-45, "BRAKE CALIPER ASSEMBLY \(2 PISTON TYPE\) : Disassembly and Assembly"](#).
7. Burnish contact surfaces brake pads and disc rotor after refinishing or replacing disc rotor, or if a soft pedal occurs at very low mileage. Refer to [BR-14, "DISC ROTOR : Inspection and Adjustment"](#).

## BRAKE CALIPER ASSEMBLY (4 PISTON TYPE)

### BRAKE CALIPER ASSEMBLY (4 PISTON TYPE) : Exploded View

INFOID:000000006038226

#### REMOVAL

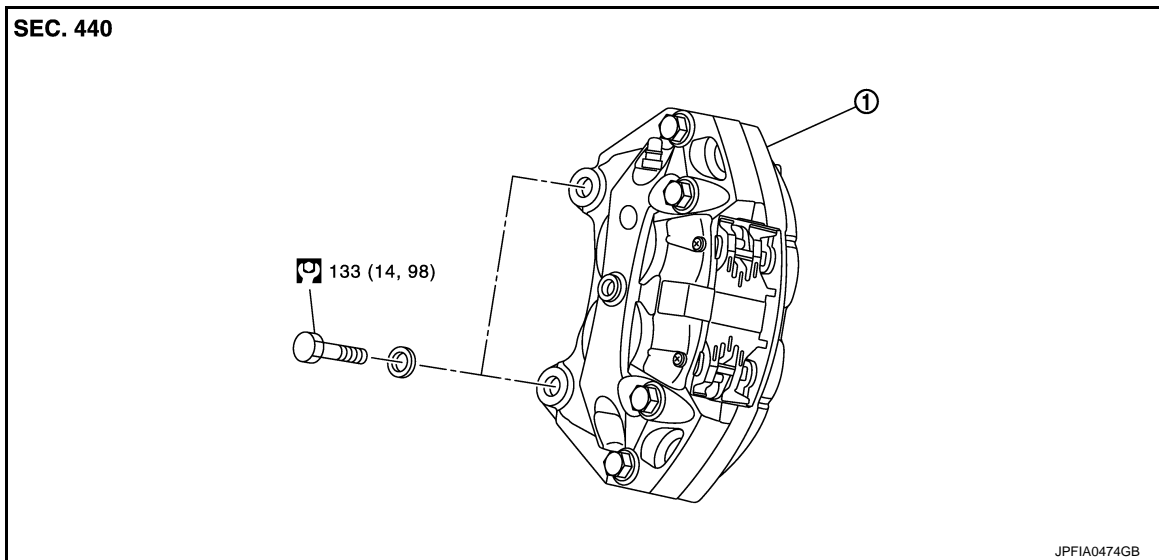

1. Brake caliper assembly

Refer to [GI-4, "Components"](#) for symbols in the figure.

#### DISASSEMBLY

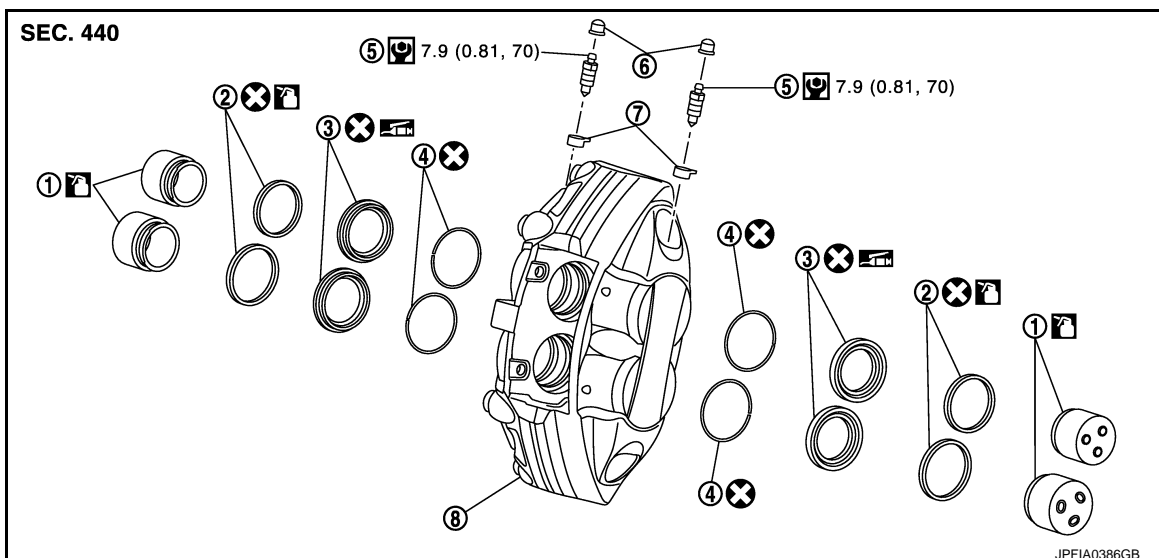

- |                   |                  |                |
|-------------------|------------------|----------------|
| 1. Piston         | 2. Piston seal   | 3. Piston boot |
| 4. Retaining ring | 5. Bleeder valve | 6. Cap         |





# FRONT DISC BRAKE

## < REMOVAL AND INSTALLATION >

7. Cap

8. Caliper

 Apply rubber grease.

 Apply brake fluid.

Refer to [GI-4, "Components"](#) for symbols not described on the above.

## BRAKE CALIPER ASSEMBLY (4 PISTON TYPE) : Removal and Installation

INFOID:000000006038227

### REMOVAL

#### **WARNING:**

Clean any dust from the brake caliper and brake pads with a vacuum dust collector. Never blow with compressed air.

#### **CAUTION:**

- Never spill or splash brake fluid on painted surfaces. Brake fluid may seriously damage paint. Wipe it off immediately and wash with water if it gets on a painted surface.
- Never depress the brake pedal while removing the brake pads because the piston may pop out.
- If the brake fluid or grease adheres to the brake caliper assembly and disc rotor, quickly wipe it off.
- Cover crowfoot and flare nut wrench with a cloth as not to damage the brake caliper assembly.

1. Remove tires with power tool.
2. Fix the disc rotor using wheel nuts.
3. Drain brake fluid. Refer to [BR-10, "Draining"](#).
4. Loosen the flare nut with a flare nut wrench and separate the brake tube from caliper. Refer to [BR-24, "FRONT : Removal and Installation"](#).
5. Remove brake caliper assembly mounting bolts, and remove brake caliper assembly.  
**CAUTION:**  
Never drop brake pad and caliper assembly.
6. Remove disc rotor. Refer to [FAX-7, "Removal and Installation"](#) (2WD), [FAX-17, "Removal and Installation"](#) (AWD).

### INSTALLATION

#### **WARNING:**

Clean any dust from the brake caliper and brake pads with a vacuum dust collector. Never blow with compressed air.

#### **CAUTION:**

- Never spill or splash brake fluid on painted surfaces. Brake fluid may seriously damage paint. Wipe it off immediately and wash with water if it gets on a painted surface.
- Never depress the brake pedal while removing the brake pads because the piston may pop out.
- If the brake fluid or grease adheres to the brake caliper assembly and disc rotor, quickly wipe it off.
- Cover crowfoot and flare nut wrench with a cloth as not to damage the brake caliper assembly.

1. Install disc rotor. Refer to [FAX-7, "Removal and Installation"](#) (2WD), [FAX-17, "Removal and Installation"](#) (AWD).
2. Install the brake caliper assembly to the steering knuckle and tighten the brake caliper assembly mounting bolts to the specified torque.  
**CAUTION:**  
Never spill or splash any grease and moisture on the brake caliper assembly mounting face, threads, mounting bolts and washers. Wipe out any grease and moisture.
3. Install brake tube to brake caliper assembly. Refer to [BR-24, "FRONT : Removal and Installation"](#).
4. Refill with new brake fluid and perform the air bleeding. Refer to [BR-11, "Bleeding Brake System"](#).
5. Check a drag of front disc brake. If any drag is found, refer to [BR-50, "BRAKE CALIPER ASSEMBLY \(4 PISTON TYPE\) : Inspection"](#).
6. Install tires with power tool.

## BRAKE CALIPER ASSEMBLY (4 PISTON TYPE) : Disassembly and Assembly

INFOID:000000006038228

### DISASSEMBLY



# FRONT DISC BRAKE

## < REMOVAL AND INSTALLATION >

### CAUTION:

- Never damage a caliper.
- Never tighten or loosen inner and outer mounting bolts of caliper.

1. Remove the brake pads. Refer to [BR-41. "BRAKE PAD \(4 PISTON TYPE\) : Removal and Installation"](#).

### CAUTION:

Never drop brake pads, shims, pad pins and clips.

2. Remove the caliper.
3. Remove the retaining ring.
4. Place a wooden block as shown in the figure, and blow air from brake tube mounting hole to remove pistons and piston boots.

### CAUTION:

Never get fingers caught in the pistons.

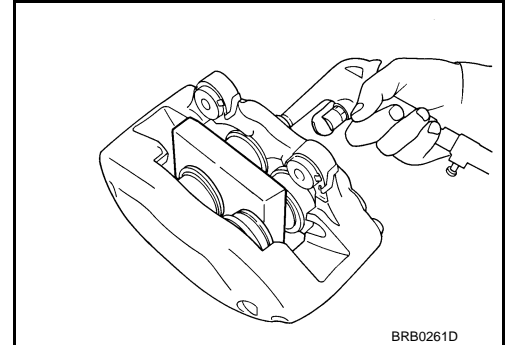

5. Remove piston seals from cylinder body using suitable tool.

### CAUTION:

Be careful not to damage a cylinder inner wall.

6. Remove bleeder valve and cap.
7. Perform inspection after disassembly. Refer to [BR-50. "BRAKE CALIPER ASSEMBLY \(4 PISTON TYPE\) : Inspection"](#).

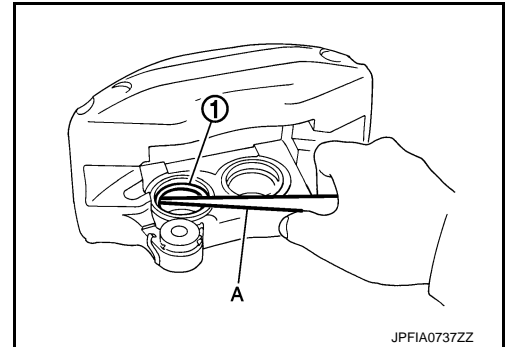

## ASSEMBLY

### CAUTION:

- Never damage a caliper.
- Never tighten or loosen inner and outer mounting bolts of caliper.

1. Install bleeder valve and cap.
2. Apply new brake fluid to piston seals (1), and install them to cylinder body.

### CAUTION:

Never reuse piston seals.

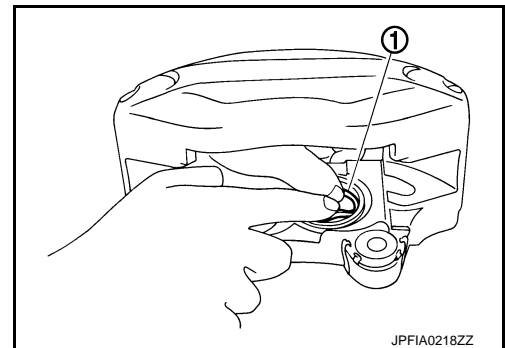

A  
B  
C  
D  
E  
BR  
G  
H  
I  
J  
K  
L  
M  
N  
O  
P

## FRONT DISC BRAKE

### < REMOVAL AND INSTALLATION >

3. Apply rubber grease to piston boots (1). Cover the piston (2) end with piston boot, and then install cylinder side lip on piston boot securely into a groove on caliper.

**CAUTION:**

**Never reuse piston boots.**

4. Apply new brake fluid to pistons. Push piston into caliper by hand and push piston boot piston-side lip into the piston groove.

**CAUTION:**

**Press the pistons evenly and vary the pressing point to prevent cylinder inner wall from being rubbed.**

5. Install the retaining ring.

**CAUTION:**

- Make sure that boot is securely engaged in the groove on caliper.
- Never reuse retaining ring.

6. Install the caliper to tighten brake caliper assembly mounting bolts to the specified torque.

7. Install the brake pads. Refer to [BR-41, "BRAKE PAD \(4 PISTON TYPE\) : Removal and Installation"](#).

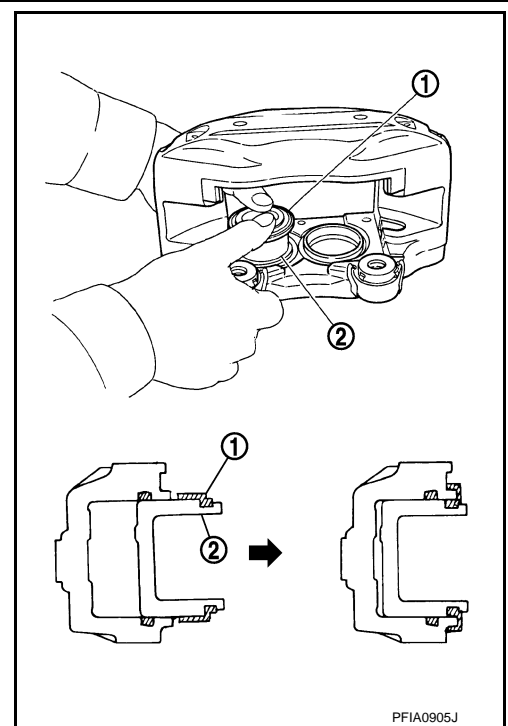

### BRAKE CALIPER ASSEMBLY (4 PISTON TYPE) : Inspection

INFOID:000000006038229

#### INSPECTION AFTER DISASSEMBLY

Check the following items and replace if necessary.

##### Caliper

Check the caliper inner wall for rust, wear, cracks or damage.

**CAUTION:**

**Always clean with new brake fluid. Never clean with mineral oil such as gasoline and light oil.**

##### Pistons

Check the surface of the piston for rust, wear, cracks or damage.

**CAUTION:**

**A piston sliding surface is plated. Never polish with sandpaper.**

#### INSPECTION AFTER INSTALLATION

1. Check a drag of front disc brake. If any drag is found, follow the procedure described below.
2. Remove brake pads. Refer to [BR-41, "BRAKE PAD \(4 PISTON TYPE\) : Removal and Installation"](#).
3. Press the pistons. Refer to [BR-41, "BRAKE PAD \(4 PISTON TYPE\) : Removal and Installation"](#).
4. Install brake pads. Refer to [BR-41, "BRAKE PAD \(4 PISTON TYPE\) : Removal and Installation"](#).
5. Depress the brake pedal several times.
6. Check a drag of front disc brake again. If any drag is found, disassemble the cylinder body. Refer to [BR-48, "BRAKE CALIPER ASSEMBLY \(4 PISTON TYPE\) : Disassembly and Assembly"](#).
7. Burnish contact surfaces brake pads and disc rotor after refinishing or replacing disc rotor, or if a soft pedal occurs at very low mileage. Refer to [BR-14, "DISC ROTOR : Inspection and Adjustment"](#).

# REAR DISC BRAKE

< REMOVAL AND INSTALLATION >

## REAR DISC BRAKE BRAKE PAD (1 PISTON TYPE)

### BRAKE PAD (1 PISTON TYPE) : Exploded View

INFOID:000000006038231

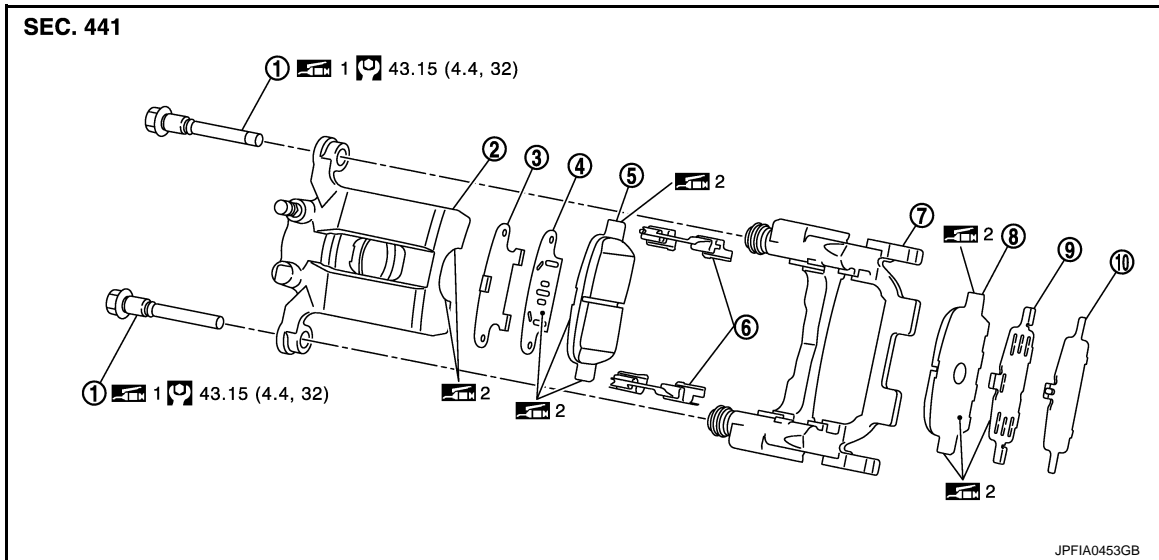

- |                      |                                     |                     |
|----------------------|-------------------------------------|---------------------|
| 1. Sliding pin bolt  | 2. Cylinder body                    | 3. Inner shim cover |
| 4. Inner shim        | 5. Inner pad (with pad wear sensor) | 6. Pad retainer     |
| 7. Torque member     | 8. Outer pad                        | 9. Outer shim       |
| 10. Outer shim cover |                                     |                     |

1: Apply rubber grease.

2: Apply PBC (Poly Butyl Cuprysil) grease or silicone-based grease.

Refer to [GI-4, "Components"](#) for symbols not described on the above.

### BRAKE PAD (1 PISTON TYPE) : Removal and Installation

INFOID:000000006038232

#### REMOVAL

##### **WARNING:**

Clean any dust from the brake caliper and brake pads with a vacuum dust collector. Never blow with compressed air.

##### **CAUTION:**

- Never depress the brake pedal while removing the brake pads because the piston may pop out.
- If the brake fluid or grease adheres to the brake caliper assembly and disc rotor, quickly wipe it off.

1. Remove tires with power tool.
2. Remove upper sliding pin bolt.
3. Suspend the cylinder body with suitable wire so that the brake hose will not stretch. Then remove the brake pads from the torque member.

##### **CAUTION:**

- Never deform the pad retainer when removing the pad retainer from the torque member.
- Never damage the piston boot.
- Never drop the brake pads, shims and shim covers.
- Remember each position of the removed brake pads.

4. Perform inspection after removal. Refer to [BR-52, "BRAKE PAD \(1 PISTON TYPE\) : Inspection"](#).

#### INSTALLATION

##### **WARNING:**

Clean any dust from the brake caliper and brake pads with a vacuum dust collector. Never blow with compressed air.

# REAR DISC BRAKE

## < REMOVAL AND INSTALLATION >

### CAUTION:

- Never depress the brake pedal while removing the brake pads because the piston may pop out.
- If the brake fluid or grease adheres to the brake caliper assembly and disc rotor, quickly wipe it off.

1. Install the torque member if the pad retainers has been removed.

### CAUTION:

- Securely assemble the pad retainers so that it will not be lifted up from the torque member.
- Never deform the pad retainers.

2. Apply PBC (Poly Butyl Cuprysil) grease or silicone-based grease to the matching faces (A) between the brake pad and shim, and install shim and shim cover to the brake pad.

### CAUTION:

Always replace the shims and shim covers when replacing the brake pad.

3. Apply PBC (Poly Butyl Cuprysil) grease or silicone-based grease to the matching faces between the brake pad and pad retainer, and install brake pad to the torque member.

4. Apply PBC (Poly Butyl Cuprysil) grease or silicone-based grease to the pawls part of cylinder body, and install cylinder body to the torque member.

### CAUTION:

- Never damage the piston boot.
- When replacing brake pad with new one, check a brake fluid level in the reservoir tank because brake fluid returns to master cylinder reservoir tank when pressing piston in.

### NOTE:

Use a disc brake piston tool to easily press piston.

5. Apply rubber grease to the sliding pin bolt, install the upper sliding pin bolt and tighten it to the specified torque.
6. Depress the brake pedal several times to check that no drag feel is present for the front disc brake. Refer to [BR-52, "BRAKE PAD \(1 PISTON TYPE\) : Inspection"](#).
7. Install tires with power tool.

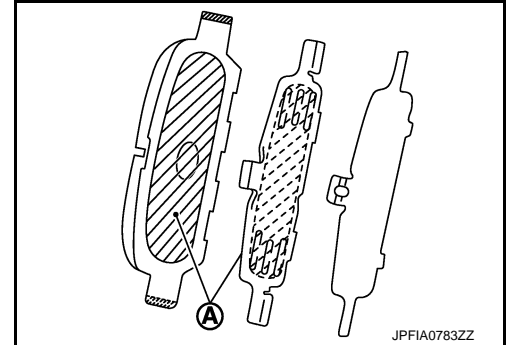

## BRAKE PAD (1 PISTON TYPE) : Inspection

INFOID:000000006038233

### INSPECTION AFTER REMOVAL

- Replace the shims and shim covers if rust is excessively attached.
- Eliminate rust on the pad retainers and the torque member. Replace them if rust is excessively attached.

### INSPECTION AFTER INSTALLATION

1. Check a drag of rear disc brake. If any drag is found, follow the procedure described below.
2. Remove brake pads. Refer to [BR-51, "BRAKE PAD \(1 PISTON TYPE\) : Removal and Installation"](#).
3. Press the pistons. Refer to [BR-51, "BRAKE PAD \(1 PISTON TYPE\) : Removal and Installation"](#).
4. Install brake pads. Refer to [BR-51, "BRAKE PAD \(1 PISTON TYPE\) : Removal and Installation"](#).
5. Depress the brake pedal several times.
6. Check a drag of rear disc brake again. If any drag is found, disassemble the cylinder body. Refer to [BR-57, "BRAKE CALIPER ASSEMBLY \(1 PISTON TYPE\) : Disassembly and Assembly"](#).
7. Burnish contact surfaces brake pads and disc rotor after refinishing or replacing brake pads, or if a soft pedal occurs at very low mileage. Refer to [BR-16, "BRAKE PAD : Inspection and Adjustment"](#).

## BRAKE PAD (2 PISTON TYPE)

# REAR DISC BRAKE

< REMOVAL AND INSTALLATION >

## BRAKE PAD (2 PISTON TYPE) : Exploded View

INFOID:000000006038234

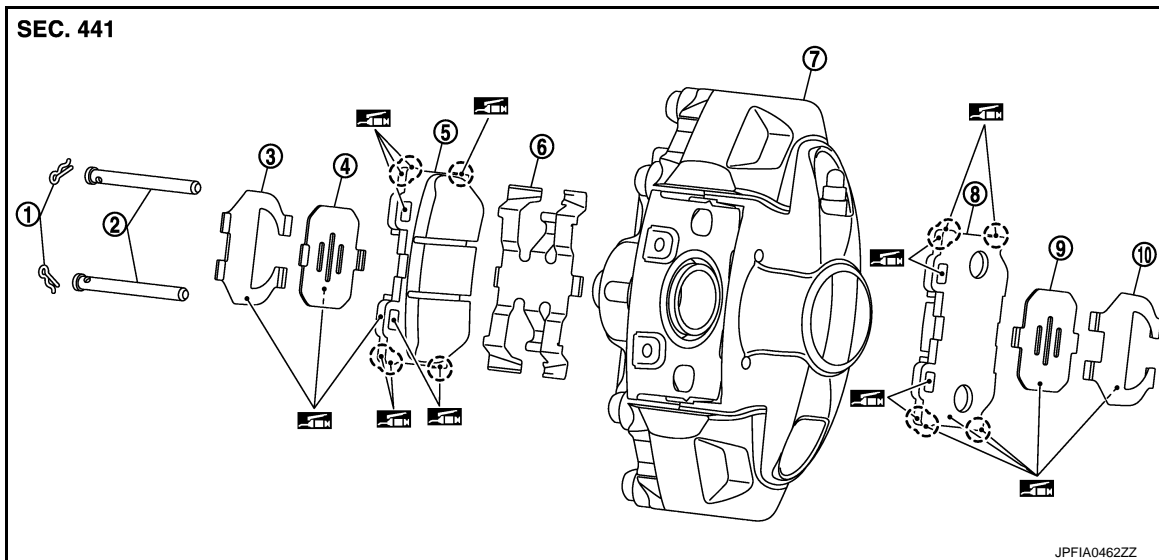

- |                      |                                     |                     |
|----------------------|-------------------------------------|---------------------|
| 1. Clip              | 2. Pad pin                          | 3. Inner shim cover |
| 4. Inner shim        | 5. Inner pad (with pad wear sensor) | 6. Cross spring     |
| 7. Caliper           | 8. Outer pad                        | 9. Outer shim       |
| 10. Outer shim cover |                                     |                     |

 Apply copper based brake grease.

Refer to [GI-4, "Components"](#) for symbols not described on the above.

## BRAKE PAD (2 PISTON TYPE) : Removal and Installation

INFOID:000000006038235

### REMOVAL

#### **WARNING:**

Clean any dust from the brake caliper and brake pads with a vacuum dust collector. Never blow with compressed air.

#### **CAUTION:**

- Never depress the brake pedal while removing the brake pads because the piston may pop out.
- If the brake fluid or grease adheres to the brake caliper assembly and disc rotor, quickly wipe it off.

1. Remove tires with power tool.
2. Remove clips from pad pins with suitable pliers.

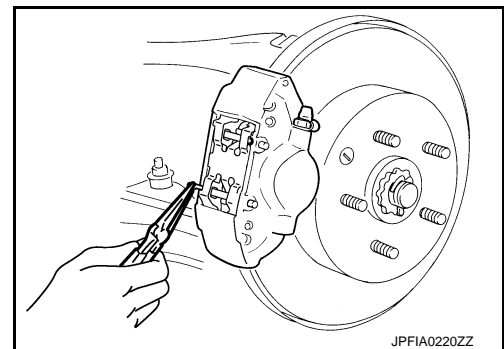

## REAR DISC BRAKE

### < REMOVAL AND INSTALLATION >

3. Remove pad pins with suitable pliers, while holding down cross spring, then remove cross spring from caliper.

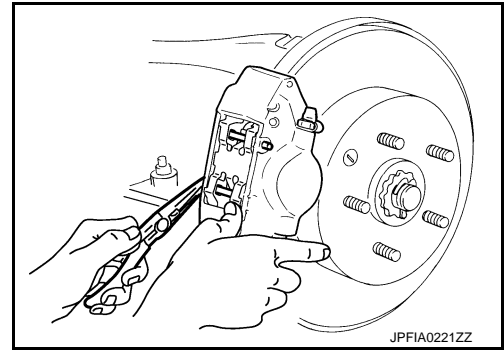

4. Remove brake pads, shims and shim covers from caliper with suitable pliers.

**CAUTION:**

- Never damage the piston boot.
- Never drop the brake pads and shims.
- Remember each position of the removed brake pads.

5. Perform inspection after removal. Refer to [BR-55, "BRAKE PAD \(2 PISTON TYPE\) : Inspection"](#).

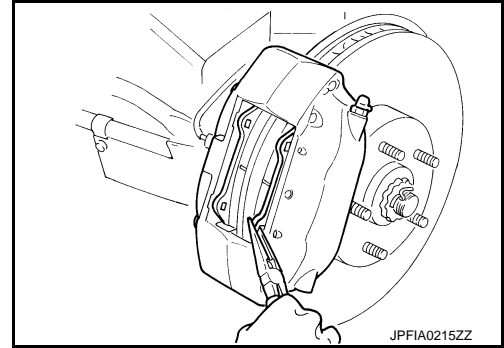

### INSTALLATION

**WARNING:**

Clean any dust from the brake caliper and brake pads with a vacuum dust collector. Never blow with compressed air.

**CAUTION:**

- Never depress the brake pedal while removing the brake pads because the piston may pop out.
- If the brake fluid or grease adheres to the brake caliper assembly and disc rotor, quickly wipe it off.

1. Apply copper based brake grease to the matching faces (A) between the shim and shim cover, and install shim and shim cover to the brake pad.

**CAUTION:**

Always replace the shims and shim covers when replacing the brake pad.

2. Apply copper based brake grease to the following matching faces:

- B: Between the brake pad and caliper.
- C: Between the brake pad and pad pin.
- D: Between the brake pad and cross spring.

3. Install the brake pads to the caliper.

**CAUTION:**

- Never damage the piston boot.
- When replacing brake pad with new one, check a brake fluid level in the reservoir tank because brake fluid returns to master cylinder reservoir tank when pressing piston in.

**NOTE:**

Use a disc brake piston tool to easily press piston.

4. Install upper pad pin from the inner side, then install firmly to the outer side through the hole in the top of brake pad.

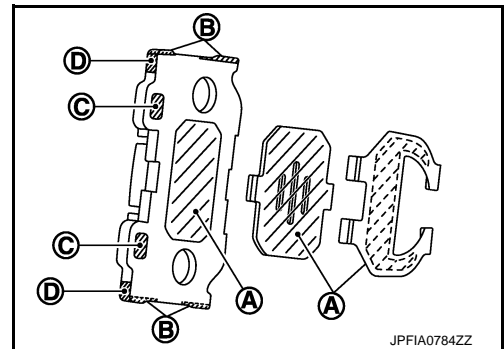

# REAR DISC BRAKE

## < REMOVAL AND INSTALLATION >

- Place the top of cross spring over the upper pad pin, press in the cross spring, install lower pad pin from the inner side to the outer side, and secure cross spring.
- Install clips to the pad pins.  
**CAUTION:**  
**If clip is not fully attached, pad pin or brake pad could fall out while vehicle is in motion.**
- Depress the brake pedal several times to check that no drag feel is present for the front disc brake. Refer to [BR-55, "BRAKE PAD \(2 PISTON TYPE\) : Inspection"](#).
- Install tires with power tool.

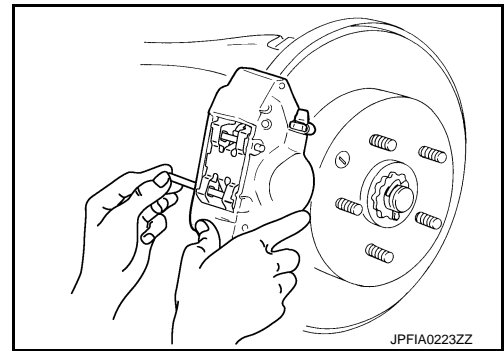

## BRAKE PAD (2 PISTON TYPE) : Inspection

INFOID:000000006038236

### INSPECTION AFTER REMOVAL

Replace the shims and shim covers if rust is excessively attached.

### INSPECTION AFTER INSTALLATION

- Check a drag of front disc brake. If any drag is found, follow the procedure described below.
- Remove brake pads. Refer to [BR-53, "BRAKE PAD \(2 PISTON TYPE\) : Removal and Installation"](#).
- Press the pistons. Refer to [BR-53, "BRAKE PAD \(2 PISTON TYPE\) : Removal and Installation"](#).
- Install brake pads. Refer to [BR-53, "BRAKE PAD \(2 PISTON TYPE\) : Removal and Installation"](#).
- Depress the brake pedal several times.
- Check a drag of front disc brake again. If any drag is found, disassemble the cylinder body. Refer to [BR-61, "BRAKE CALIPER ASSEMBLY \(2 PISTON TYPE\) : Disassembly and Assembly"](#).
- Burnish contact surfaces brake pads and disc rotor after refinishing or replacing brake pads, or if a soft pedal occurs at very low mileage. Refer to [BR-16, "BRAKE PAD : Inspection and Adjustment"](#).

## BRAKE CALIPER ASSEMBLY (1 PISTON TYPE)

## BRAKE CALIPER ASSEMBLY (1 PISTON TYPE) : Exploded View

INFOID:000000006038237

### REMOVAL

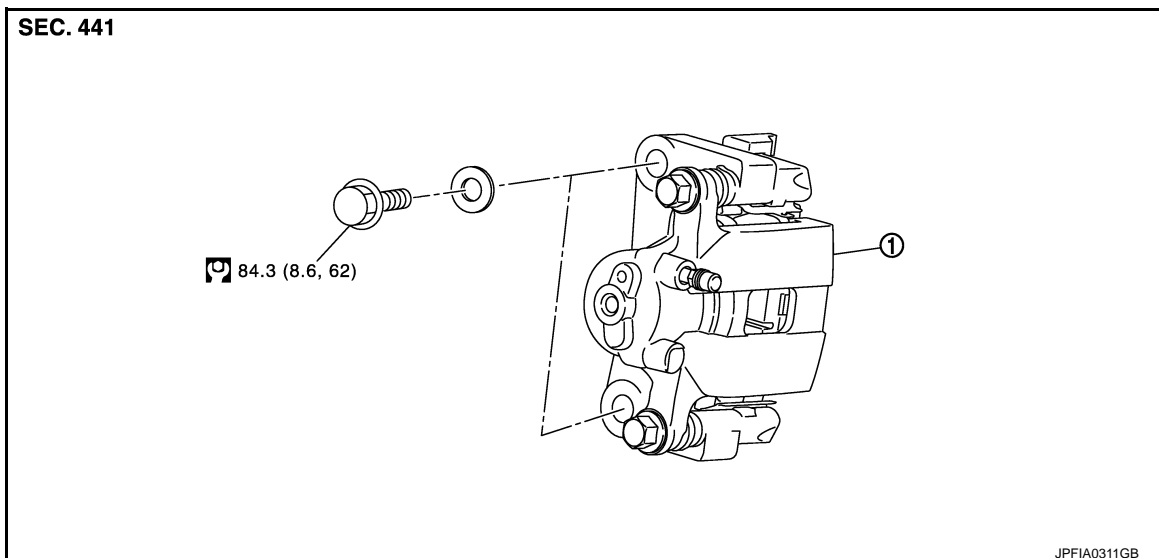

- Brake caliper assembly

Refer to [GI-4, "Components"](#) for symbols in the figure.

### DISASSEMBLY



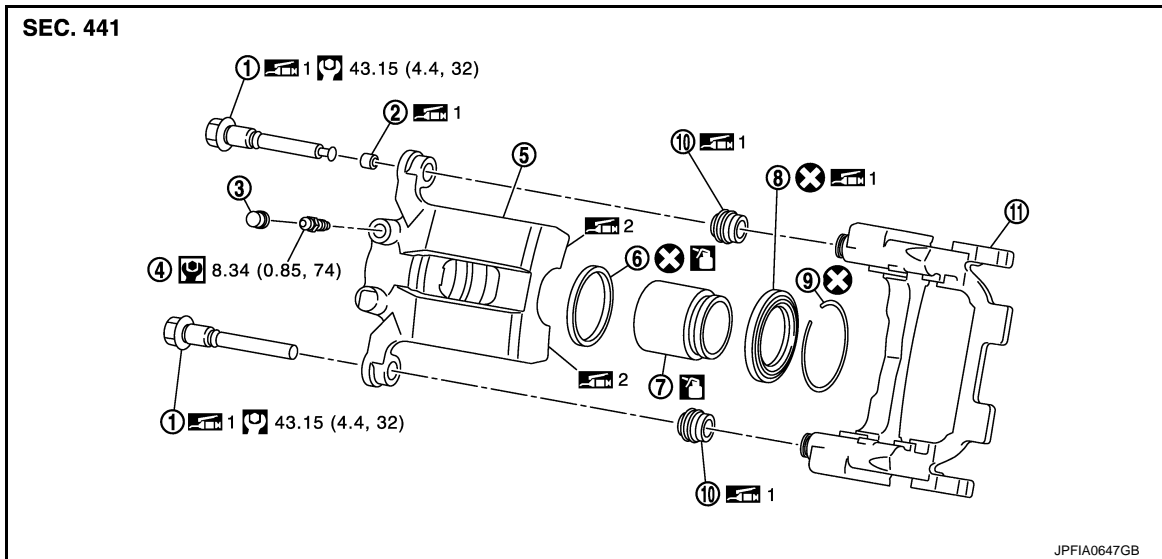

# REAR DISC BRAKE

## < REMOVAL AND INSTALLATION >



- |                      |                   |                   |
|----------------------|-------------------|-------------------|
| 1. Sliding pin bolt  | 2. Bushing        | 3. Cap            |
| 4. Bleeder valve     | 5. Cylinder body  | 6. Piston seal    |
| 7. Piston            | 8. Piston boot    | 9. Retaining ring |
| 10. Sliding pin boot | 11. Torque member |                   |

 1: Apply rubber grease.

 2: Apply PBC (Poly Butyl Cuprysil) grease or silicone-based grease.

 : Apply brake fluid.

Refer to [GI-4, "Components"](#) for symbols not described on the above.

## BRAKE CALIPER ASSEMBLY (1 PISTON TYPE) : Removal and Installation

INFOID:000000006038238

### REMOVAL

#### **WARNING:**

Clean any dust from the brake caliper and brake pads with a vacuum dust collector. Never blow with compressed air.

#### **CAUTION:**

- Never spill or splash brake fluid on painted surfaces. Brake fluid may seriously damage paint. Wipe it off immediately and wash with water if it gets on a painted surface.
- Never depress the brake pedal while removing the brake pads because the piston may pop out.
- If the brake fluid or grease adheres to the brake caliper assembly and disc rotor, quickly wipe it off.

1. Remove tires with power tool.
2. Fix the disc rotor using wheel nuts.
3. Drain brake fluid. Refer to [BR-10, "Draining"](#).
4. Remove union bolt and copper washer, and separate brake hose from caliper assembly. Refer to [BR-29, "REAR : Removal and Installation"](#).
5. Remove torque member mounting bolts, and remove brake caliper assembly.  
**CAUTION:**  
Never drop brake pad and caliper assembly.
6. Remove disc rotor. Refer to [RAX-8, "Removal and Installation"](#).

### INSTALLATION

#### **WARNING:**

Clean any dust from the brake caliper and brake pads with a vacuum dust collector. Never blow with compressed air.

#### **CAUTION:**



# REAR DISC BRAKE

## < REMOVAL AND INSTALLATION >

- Never spill or splash brake fluid on painted surfaces. Brake fluid may seriously damage paint. Wipe it off immediately and wash with water if it gets on a painted surface.
  - Never depress the brake pedal while removing the brake pads because the piston may pop out.
  - If the brake fluid or grease adheres to the brake caliper assembly and disc rotor, quickly wipe it off.
1. Install disc rotor. Refer to [RAX-8, "Removal and Installation"](#).
  2. Install the brake caliper assembly to the axle housing and tighten the torque member mounting bolts to the specified torque.  
**CAUTION:**  
Never spill or splash any grease and moisture on the brake caliper assembly mounting face, threads, mounting bolts and washers. Wipe out any grease and moisture.
  3. Install brake hose and copper washers to brake caliper assembly. Refer to [BR-29, "REAR : Removal and Installation"](#).
  4. Refill with new brake fluid and perform the air bleeding. Refer to [BR-11, "Bleeding Brake System"](#).
  5. Check a drag of rear disc brake. If any drag is found, refer to [BR-59, "BRAKE CALIPER ASSEMBLY \(1 PISTON TYPE\) : Inspection"](#).
  6. Install tires with power tool.

## BRAKE CALIPER ASSEMBLY (1 PISTON TYPE) : Disassembly and Assembly

INFOID:000000006038239

### DISASSEMBLY

#### NOTE:

Never remove the torque member, brake pad and pad retainers when disassembling and assembling the cylinder body.

1. Remove the sliding pin bolt, and remove the cylinder body from the torque member.

#### CAUTION:

Fix the brake pad at suitable tape so that the brake pad will not drop.

2. Remove sliding pin boots from torque member.
3. Remove bushing from sliding pin bolt.
4. Remove the retaining ring (1).

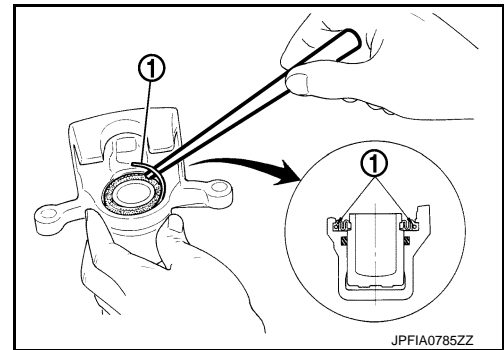

5. Place a wooden block as shown in the figure, and blow air from union bolt mounting hole to remove pistons and piston boot.

#### CAUTION:

Never get fingers caught in the pistons.

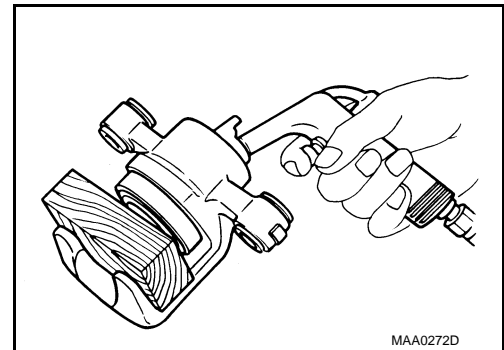

## REAR DISC BRAKE

### < REMOVAL AND INSTALLATION >

- Remove piston seal from cylinder body using suitable tool.

**CAUTION:**

**Be careful not to damage a cylinder inner wall.**

- Remove bleeder valve and cap.
- Perform inspection after disassembly. Refer to [BR-59, "BRAKE CALIPER ASSEMBLY \(1 PISTON TYPE\) : Inspection"](#).

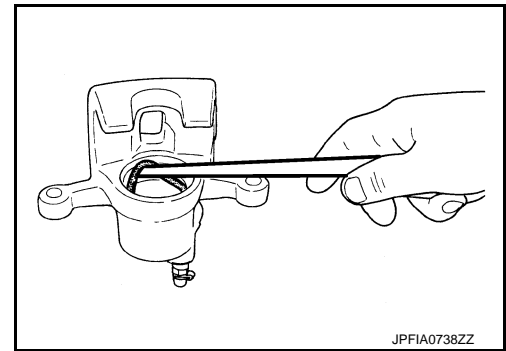

### ASSEMBLY

- Install bleeder valve and cap.
- Apply new brake fluid to piston seal (1), and install them to cylinder body.

**CAUTION:**

**Never reuse piston seal.**

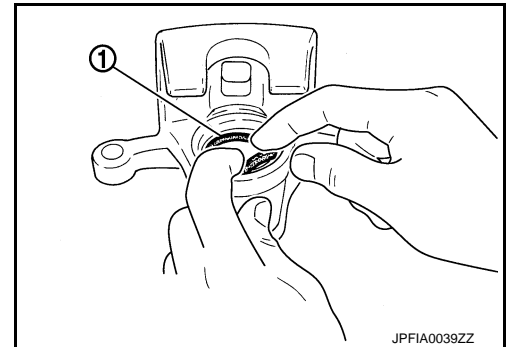

- Apply rubber grease to piston boot (1). Cover the piston (2) end with piston boot, and then install cylinder side lip on piston boot securely into a groove on cylinder body.

**CAUTION:**

**Never reuse piston boots.**

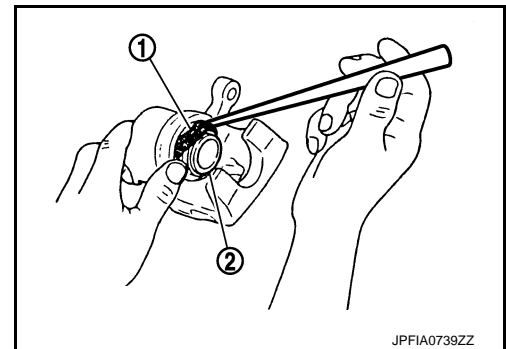

- Apply new brake fluid to piston (1). Push piston into cylinder body by hand and push piston boot (2) piston-side lip into the piston groove.

**CAUTION:**

**Press the pistons evenly and vary the pressing point to prevent cylinder inner wall from being rubbed.**

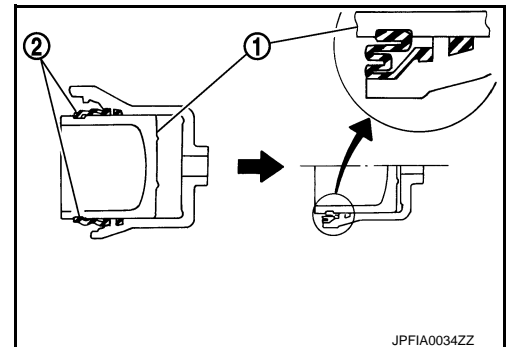

# REAR DISC BRAKE

## < REMOVAL AND INSTALLATION >

5. Install the retaining ring.

**CAUTION:**

- Make sure that boot is securely engaged in the groove on caliper.
- Never reuse retaining ring.

6. Apply rubber grease to bushing, and install bushing to sliding pin bolt.

7. Apply rubber grease to sliding pin boots, and install sliding pin boots to torque member.

8. Apply PBC (Poly Butyl Cuprysil) grease or silicone-based grease to the pawls part of cylinder body.

9. Apply rubber grease to sliding pin bolt, and install the cylinder body to tighten sliding pin bolts to the specified torque.

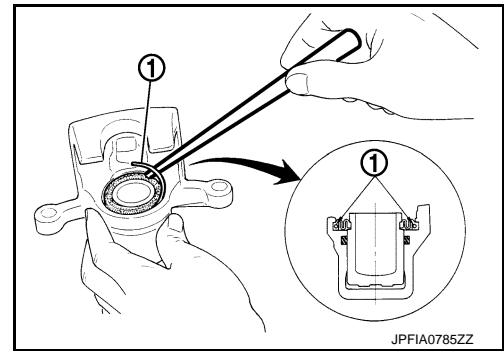

## BRAKE CALIPER ASSEMBLY (1 PISTON TYPE) : Inspection

INFOID:000000006038240

### INSPECTION AFTER DISASSEMBLY

Check the following items and replace if necessary.

#### Cylinder Body

Check the cylinder inner wall for rust, wear, cracks or damage.

**CAUTION:**

**Always clean with new brake fluid. Never clean with mineral oil such as gasoline and light oil.**

#### Torque Member

Check the torque member for rust, wear, cracks or damage.

#### Piston

Check the surface of the piston for rust, wear, cracks or damage.

**CAUTION:**

**A piston sliding surface is plated. Never polish with sandpaper.**

#### Sliding Pin Bolt, Sliding Pin Boot and Bushing

Check the sliding pin bolts, sliding pin boots and bushing for rust, wear, cracks or damage.

### INSPECTION AFTER INSTALLATION

1. Check a drag of rear disc brake. If any drag is found, follow the procedure described below.

2. Remove brake pads. Refer to [BR-51, "BRAKE PAD \(1 PISTON TYPE\) : Removal and Installation"](#).

3. Press the pistons. Refer to [BR-51, "BRAKE PAD \(1 PISTON TYPE\) : Removal and Installation"](#).

4. Install brake pads. Refer to [BR-51, "BRAKE PAD \(1 PISTON TYPE\) : Removal and Installation"](#).

5. Depress the brake pedal several times.

6. Check a drag of rear disc brake again. If any drag is found, disassemble the cylinder body. Refer to [BR-57, "BRAKE CALIPER ASSEMBLY \(1 PISTON TYPE\) : Disassembly and Assembly"](#).

7. Burnish contact surfaces brake pads and disc rotor after refinishing or replacing disc rotor, or if a soft pedal occurs at very low mileage. Refer to [BR-16, "DISC ROTOR : Inspection and Adjustment"](#).

## BRAKE CALIPER ASSEMBLY (2 PISTON TYPE)

## BRAKE CALIPER ASSEMBLY (2 PISTON TYPE) : Exploded View

INFOID:000000006038241

### REMOVAL

# REAR DISC BRAKE

## < REMOVAL AND INSTALLATION >

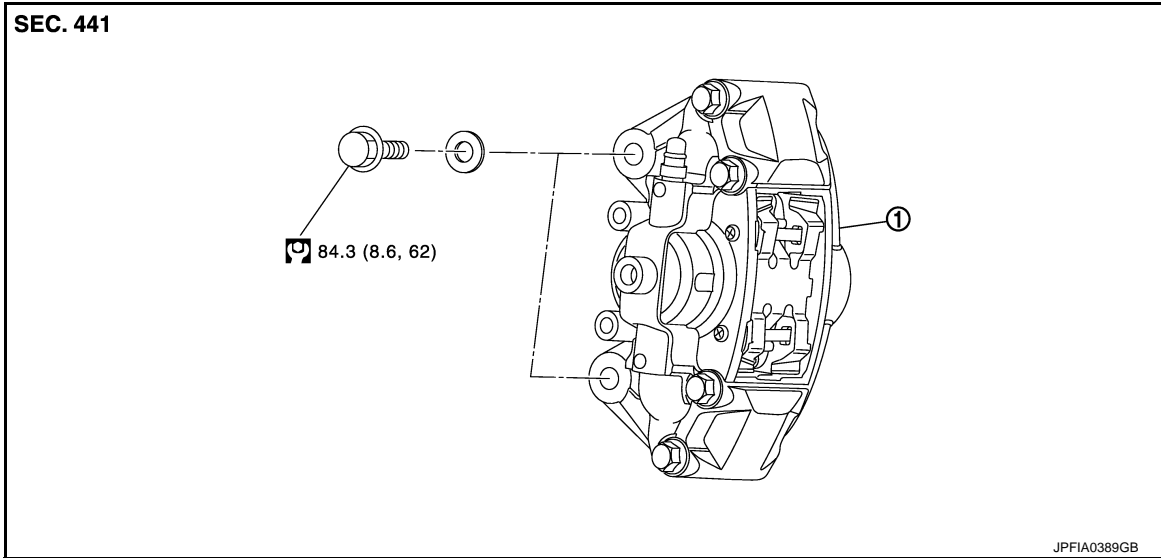

1. Brake caliper assembly

Refer to [GI-4, "Components"](#) for symbols in the figure.

## DISASSEMBLY

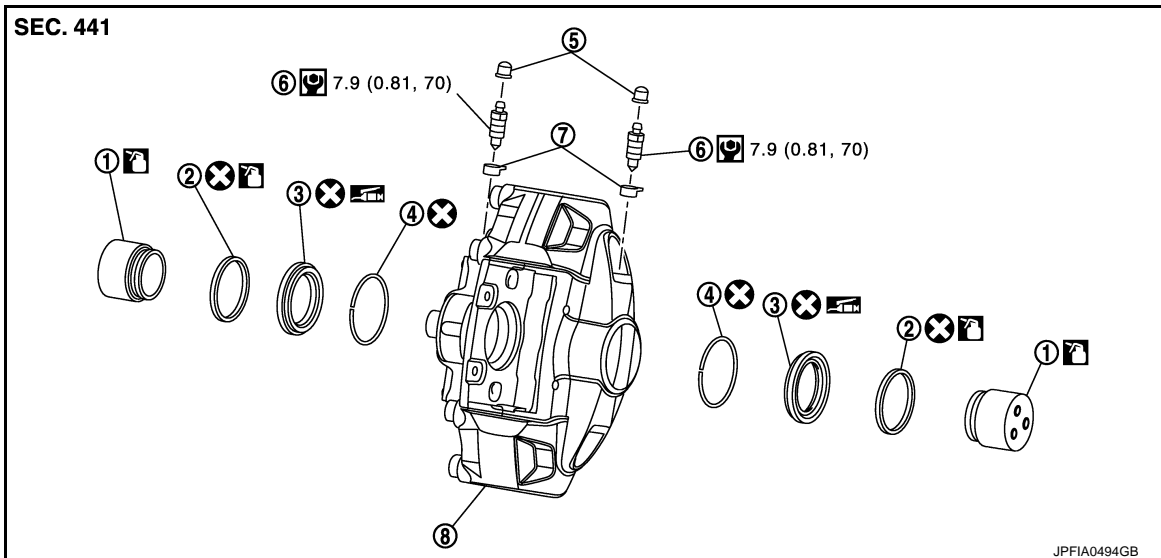

- |                   |                |                  |
|-------------------|----------------|------------------|
| 1. Piston         | 2. Piston seal | 3. Piston boot   |
| 4. Retaining ring | 5. Cap         | 6. Bleeder valve |
| 7. Cap            | 8. Caliper     |                  |

: Apply rubber grease.

: Apply brake fluid.

Refer to [GI-4, "Components"](#) for symbols not described on the above.

## BRAKE CALIPER ASSEMBLY (2 PISTON TYPE) : Removal and Installation

INFOID:000000006038242

### REMOVAL

#### **WARNING:**

Clean any dust from the brake caliper and brake pads with a vacuum dust collector. Never blow with compressed air.

#### **CAUTION:**

# REAR DISC BRAKE

## < REMOVAL AND INSTALLATION >

- **Never spill or splash brake fluid on painted surfaces. Brake fluid may seriously damage paint. Wipe it off immediately and wash with water if it gets on a painted surface.**
  - **Never depress the brake pedal while removing the brake pads because the piston may pop out.**
  - **If the brake fluid or grease adheres to the brake caliper assembly and disc rotor, quickly wipe it off.**
  - **Cover crowfoot and flare nut wrench with a cloth as not to damage the brake caliper assembly.**
1. Remove tires with power tool.
  2. Fix the disc rotor using wheel nuts.
  3. Drain brake fluid. Refer to [BR-10, "Draining"](#).
  4. Loosen the flare nut with a flare nut wrench and separate the brake tube from caliper. Refer to [BR-29, "REAR : Removal and Installation"](#).
  5. Remove the brake hose bracket. Refer to [BR-29, "REAR : Removal and Installation"](#).
  6. Remove brake caliper assembly mounting bolts, and remove brake caliper assembly.  
**CAUTION:**  
**Never drop brake pad and caliper assembly.**
  7. Remove disc rotor. Refer to [RAX-8, "Removal and Installation"](#).

## INSTALLATION

### **WARNING:**

**Clean any dust from the brake caliper and brake pads with a vacuum dust collector. Never blow with compressed air.**

### **CAUTION:**

- **Never spill or splash brake fluid on painted surfaces. Brake fluid may seriously damage paint. Wipe it off immediately and wash with water if it gets on a painted surface.**
  - **Never depress the brake pedal while removing the brake pads because the piston may pop out.**
  - **If the brake fluid or grease adheres to the brake caliper assembly and disc rotor, quickly wipe it off.**
  - **Cover crowfoot and flare nut wrench with a cloth as not to damage the brake caliper assembly.**
1. Install disc rotor. Refer to [RAX-8, "Removal and Installation"](#).
  2. Install the brake caliper assembly to the axle housing and tighten the brake caliper assembly mounting bolts to the specified torque.  
**CAUTION:**  
**Never spill or splash any grease and moisture on the brake caliper assembly mounting face, threads, mounting bolts and washers. Wipe out any grease and moisture.**
  3. Install brake hose bracket (caliper side). Refer to [BR-29, "REAR : Removal and Installation"](#).
  4. Install brake tube to brake caliper assembly. Refer to [BR-29, "REAR : Removal and Installation"](#).
  5. Refill with new brake fluid and perform the air bleeding. Refer to [BR-11, "Bleeding Brake System"](#).
  6. Check a drag of rear disc brake. If any drag is found, refer to [BR-63, "BRAKE CALIPER ASSEMBLY \(2 PISTON TYPE\) : Inspection"](#).
  7. Install tires with power tool.

## BRAKE CALIPER ASSEMBLY (2 PISTON TYPE) : Disassembly and Assembly

INFOID:000000006038243

## DISASSEMBLY

### **CAUTION:**

- **Never damage a caliper.**
  - **Never tighten or loosen inner and outer mounting bolts of caliper.**
1. Remove the brake pads. Refer to [BR-53, "BRAKE PAD \(2 PISTON TYPE\) : Removal and Installation"](#).  
**CAUTION:**  
**Never drop brake pads, shims, shim covers, pad pins and clips.**
  2. Remove the caliper.
  3. Remove the retaining ring.

## REAR DISC BRAKE

### < REMOVAL AND INSTALLATION >

4. Place a wooden block as shown in the figure, and blow air from brake tube mounting hole to remove pistons and piston boots.

**CAUTION:**

**Never get fingers caught in the pistons.**

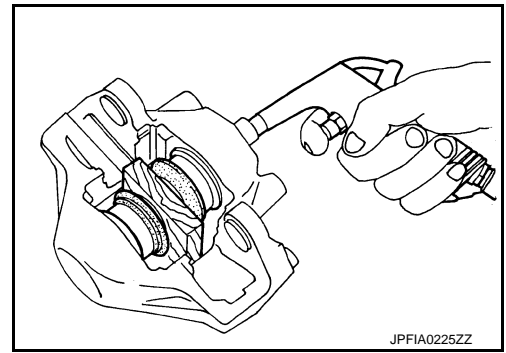

5. Remove piston seals from cylinder body using suitable tool.

**CAUTION:**

**Be careful not to damage a cylinder inner wall.**

6. Remove bleeder valve and cap.
7. Perform inspection after disassembly. Refer to [BR-63, "BRAKE CALIPER ASSEMBLY \(2 PISTON TYPE\) : Inspection"](#).

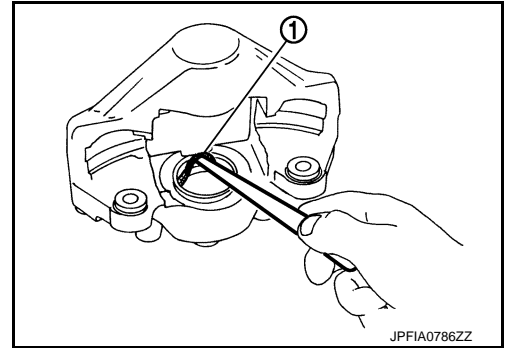

### ASSEMBLY

**CAUTION:**

- **Never damage a caliper.**
- **Never tighten or loosen inner and outer mounting bolts of caliper.**

1. Install bleeder valve and cap.
2. Apply new brake fluid to piston seals (1), and install them to cylinder body.

**CAUTION:**

**Never reuse piston seals.**

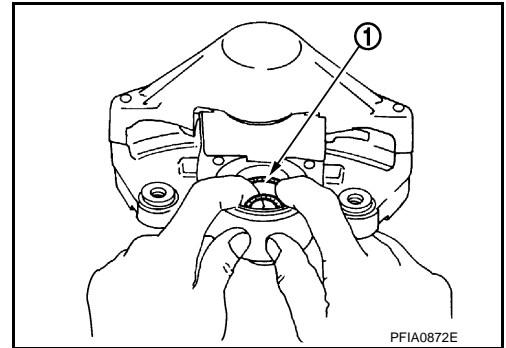

## REAR DISC BRAKE

### < REMOVAL AND INSTALLATION >

3. Apply rubber grease to piston boots (1). Cover the piston (2) end with piston boot, and then install cylinder side lip on piston boot securely into a groove on caliper.

**CAUTION:**

**Never reuse piston boots.**

4. Apply new brake fluid to pistons. Push piston into caliper by hand and push piston boot piston-side lip into the piston groove.

**CAUTION:**

**Press the pistons evenly and vary the pressing point to prevent cylinder inner wall from being rubbed.**

5. Install the retaining ring.

**CAUTION:**

- Make sure that boot is securely engaged in the groove on caliper.
- Never reuse retaining ring.

6. Install the caliper to tighten brake caliper assembly mounting bolts to the specified torque.

7. Install the brake pads. Refer to [BR-53, "BRAKE PAD \(2 PISTON TYPE\) : Removal and Installation"](#).

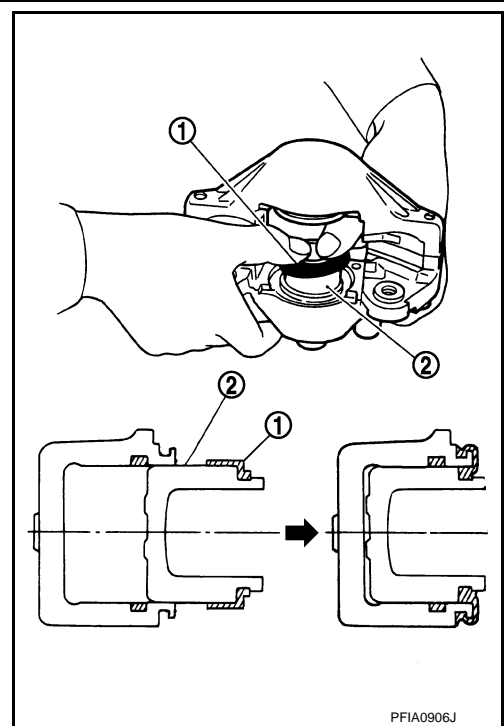

### BRAKE CALIPER ASSEMBLY (2 PISTON TYPE) : Inspection

INFOID:000000006038244

#### INSPECTION AFTER DISASSEMBLY

Check the following items and replace if necessary.

##### Caliper

Check the caliper inner wall for rust, wear, cracks or damage.

**CAUTION:**

**Always clean with new brake fluid. Never clean with mineral oil such as gasoline and light oil.**

##### Pistons

Check the surface of the piston for rust, wear, cracks or damage.

**CAUTION:**

**A piston sliding surface is plated. Never polish with sandpaper.**

#### INSPECTION AFTER INSTALLATION

1. Check a drag of rear disc brake. If any drag is found, follow the procedure described below.
2. Remove brake pads. Refer to [BR-53, "BRAKE PAD \(2 PISTON TYPE\) : Removal and Installation"](#).
3. Press the pistons. Refer to [BR-53, "BRAKE PAD \(2 PISTON TYPE\) : Removal and Installation"](#).
4. Install brake pads. Refer to [BR-53, "BRAKE PAD \(2 PISTON TYPE\) : Removal and Installation"](#).
5. Depress the brake pedal several times.
6. Check a drag of rear disc brake again. If any drag is found, disassemble the cylinder body. Refer to [BR-61, "BRAKE CALIPER ASSEMBLY \(2 PISTON TYPE\) : Disassembly and Assembly"](#).
7. Burnish contact surfaces brake pads and disc rotor after refinishing or replacing disc rotor, or if a soft pedal occurs at very low mileage. Refer to [BR-16, "DISC ROTOR : Inspection and Adjustment"](#).

## SERVICE DATA AND SPECIFICATIONS (SDS)

< SERVICE DATA AND SPECIFICATIONS (SDS)

# SERVICE DATA AND SPECIFICATIONS (SDS)

## SERVICE DATA AND SPECIFICATIONS (SDS)

### General Specifications

INFOID:000000006038279

#### FRONT 2 PISTON, REAR 1 PISTON TYPE

Unit: mm (in)

Front brake	Cylinder bore diameter	45.0 (1.772) × 2
	Pad length × width × thickness	130 × 50.0 × 11.0 (5.12 × 1.969 × 0.433)
	Rotor outer diameter × thickness	320 × 28.0 (12.60 × 1.102)
Rear brake	Cylinder bore diameter	42.86 (1.687)
	Pad length × width × thickness	83.0 × 31.9 × 8.5 (3.268 × 1.256 × 0.335)
	Rotor outer diameter × thickness	308 × 16.0 (12.13 × 0.630)
Master cylinder	Cylinder bore diameter	25.4 (1)
Control valve	Valve type	Electric brake force distribution
Brake booster	Diaphragm diameter	Primary: 241.5 (9.51)
		Secondary: 245.4 (9.66)
Recommended brake fluid		Refer to <a href="#">MA-12, "Fluids and Lubricants"</a> .

#### FRONT 4 PISTON, REAR 2 PISTON TYPE

Unit: mm (in)

Front brake	Cylinder bore diameter	41.3 (1.626) × 2 + 44.45 (1.750) × 2
	Pad length × width × thickness	123.2 × 55.0 × 11.0 (4.85 × 2.165 × 0.433)
	Rotor outer diameter × thickness	355 × 32.0 (13.98 × 1.260)
Rear brake	Cylinder bore diameter	41.3 (1.626) × 2
	Pad length × width × thickness	95.8 × 41.5 × 8.5 (3.772 × 1.634 × 0.335)
	Rotor outer diameter × thickness	350 × 20.0 (13.78 × 0.787)
Master cylinder	Cylinder bore diameter	27.0 (17/16)
Control valve	Valve type	Electric brake force distribution
Brake booster	Diaphragm diameter	Primary: 241.5 (9.51)
		Secondary: 245.4 (9.66)
Recommended brake fluid		Refer to <a href="#">MA-12, "Fluids and Lubricants"</a> .

### Brake Pedal

INFOID:000000006038247

Unit: mm (in)

Item	Standard
Brake pedal height	170.5 – 180.5 (6.71 – 7.11)
Depressed brake pedal height [Depressing 490 N (50 kg, 110 lb) while turning the engine ON]	110.32 (4.34) or more
Clearance between stop lamp switch and brake switch threaded end and the stopper rubber	0.20 – 1.96 (0.0079 – 0.0772)
Brake pedal play	3 – 11 (0.12 – 0.43)

### Brake Booster

INFOID:000000006038248

Unit: mm (in)

Item	Standard
Input rod length	135.7 – 136.7 (5.34 – 5.38)



# SERVICE DATA AND SPECIFICATIONS (SDS)

## < SERVICE DATA AND SPECIFICATIONS (SDS)

### Front Disc Brake

INFOID:000000006038249

#### 2 PISTON TYPE

Unit: mm (in)

Item		Limit
Brake pad	Wear thickness	2.0 (0.079)
	Wear thickness	26.0 (1.024)
Disc rotor	Thickness variation (measured at 8 positions)	0.015 (0.0006)
	Runout (with it attached to the vehicle)	0.035 (0.0014)

#### 4 PISTON TYPE

Unit mm (in)

Item		Limit
Brake pad	Wear thickness	2.0 (0.079)
	Wear thickness	30.0 (1.181)
Disc rotor	Thickness variation (measured at 8 positions)	0.015 (0.0006)
	Runout (with it attached to the vehicle)	0.035 (0.0014)

### Rear Disc Brake

INFOID:000000006038250

#### 1 PISTON TYPE

Unit: mm (in)

Item		Limit
Brake pad	Wear thickness	2.0 (0.079)
	Wear thickness	14.0 (0.551)
Disc rotor	Thickness variation (measured at 8 positions)	0.015 (0.0006)
	Runout (with it attached to the vehicle)	0.055 (0.0022)

#### 2 PISTON TYPE

Unit: mm (in)

Item		Limit
Brake pad	Wear thickness	2.0 (0.079)
	Wear thickness	18.0 (0.709)
Disc rotor	Thickness variation (measured at 8 positions)	0.015 (0.0006)
	Runout (with it attached to the vehicle)	0.055 (0.0022)