

SECTION **SE**
SEAT

A
B
C
D
E
F
G
H
I
SE
K
L
M
N
O
P

CONTENTS

PRECAUTION	4	HEATED SEAT SYSTEM : Component Parts Location	11
PRECAUTIONS	4	HEATED SEAT SYSTEM : Component Description	12
Precaution for Supplemental Restraint System (SRS) "AIR BAG" and "SEAT BELT PRE-TENSIONER"	4	SYSTEM	13
Precaution Necessary for Steering Wheel Rotation after Battery Disconnect	4	POWER SEAT SYSTEM	13
Service Notice	5	POWER SEAT SYSTEM : System Description	13
Precaution for Work	5	LUMBAR SUPPORT SYSTEM	13
PREPARATION	6	LUMBAR SUPPORT SYSTEM : System Description	13
PREPARATION	6	CLIMATE CONTROLLED SEAT SYSTEM	13
Special Service Tool	6	CLIMATE CONTROLLED SEAT SYSTEM : System Diagram	13
Commercial Service Tool	6	CLIMATE CONTROLLED SEAT SYSTEM : System Description	14
CLIP LIST	7	CLIMATE CONTROLLED SEAT SYSTEM : Fail-safe	14
Clip List	7	HEATED SEAT SYSTEM	15
SYSTEM DESCRIPTION	8	HEATED SEAT SYSTEM : System Diagram	16
COMPONENT PARTS	8	HEATED SEAT SYSTEM : System Description	16
POWER SEAT SYSTEM	8	ECU DIAGNOSIS INFORMATION	17
POWER SEAT SYSTEM : Component Parts Location	8	CLIMATE CONTROLLED SEAT CONTROL UNIT	17
POWER SEAT SYSTEM : Component Description	8	Reference Value	17
LUMBAR SUPPORT SYSTEM	8	Fail-safe	18
LUMBAR SUPPORT SYSTEM : Component Parts Location	9	HEATED SEAT CONTROL UNIT (DRIVER SIDE)	20
LUMBAR SUPPORT SYSTEM : Component Description	9	Reference Value	20
CLIMATE CONTROLLED SEAT SYSTEM	9	HEATED SEAT CONTROL UNIT (PASSENGER SIDE)	21
CLIMATE CONTROLLED SEAT SYSTEM : Component Parts Location	10	Reference Value	21
CLIMATE CONTROLLED SEAT SYSTEM : Component Description	10	WIRING DIAGRAM	22
HEATED SEAT SYSTEM	11		

POWER SEAT CONTROL SYSTEM (PAS-SENGER SIDE)	22	CLIMATE CONTROLLED SEAT CUSHION BLOWER MOTOR	73
Wiring Diagram	22	Component Function Check	73
LUMBAR SUPPORT SYSTEM	27	Diagnosis Procedure	73
Wiring Diagram	27	CLIMATE CONTROLLED SEAT SWITCH INDICATOR	76
CLIMATE CONTROLLED SEAT SYSTEM	34	Component Function Check	76
Wiring Diagram	34	Diagnosis Procedure	76
HEATED SEAT SYSTEM	44	CLIMATE CONTROLLED SEAT BLOWER FILTER	78
Wiring Diagram	44	Diagnosis Procedure	78
BASIC INSPECTION	52	HEATED SEAT SWITCH	79
DIAGNOSIS AND REPAIR WORK FLOW	52	Component Function Check	79
Work Flow	52	Diagnosis Procedure	79
DTC/CIRCUIT DIAGNOSIS	53	Component Inspection	80
POWER SUPPLY AND GROUND CIRCUIT	53	HEATED SEAT RELAY	81
CLIMATE CONTROLLED SEAT CONTROL UNIT.. 53		Component Function Check	81
CLIMATE CONTROLLED SEAT CONTROL UNIT		Diagnosis Procedure	81
: Diagnosis Procedure	53	Component Inspection	82
CLIMATE CONTROLLED SEAT CONTROL UNIT		SEATBACK HEATER	83
: Component Inspection	56	Component Function Check	83
SEAT CUSHION HEATER	57	Diagnosis Procedure	83
SEAT CUSHION HEATER : Diagnosis Procedure..	57	Component Inspection	83
SEATBACK HEATER	59	HEATED SEAT SWITCH INDICATOR	85
SEATBACK HEATER : Diagnosis Procedure	59	Component Function Check	85
HEATED SEAT SWITCH	60	Diagnosis Procedure	85
HEATED SEAT SWITCH : Diagnosis Procedure ...	60	SYMPTOM DIAGNOSIS	86
CLIMATE CONTROLLED SEAT SWITCH	62	CLIMATE CONTROLLED SEAT DOES NOT OPERATE.	86
Component Function Check	62	Diagnosis Procedure	86
Diagnosis Procedure	62	TEMPERATURE ADJUSTMENT IS IMPOSSIBLE	87
Component Inspection	64	Description	87
SEATBACK THRMAL ELECTRIC UNIT	65	Diagnosis Procedure	87
Component Function Check	65	CLIMATE CONTROLLED SEAT ACTIVATES ONCE BUT STOPS IMMEDIATELY	89
Diagnosis Procedure	65	Description	89
SEATBACK THRMAL ELECTRIC UNIT SENSOR	67	Diagnosis Procedure	89
Component Function Check	67	SEAT SWITCH INDICATOR IS NOT ILLUMINATED IN HEAT OR COOL POSITION	90
Diagnosis Procedure	67	Diagnosis Procedure	90
Component Inspection	68	HEATED SEAT DOES NOT OPERATE	91
SEAT CUSHION THRMAL ELECTRIC UNIT ...	69	Diagnosis Procedure	91
Component Function Check	69	SEATBACK HEATER ONLY DOES NOT OPERATE	92
Diagnosis Procedure	69	Diagnosis Procedure	92
SEAT CUSHION THRMAL ELECTRIC UNIT SENSOR	71		
Component Function Check	71		
Diagnosis Procedure	71		
Component Inspection	72		

CANNOT ADJUST HEATED SEAT TEMPERATURE	93	CLIMATE CONTROLLED SEAT UNIT	114	
Diagnosis Procedure	93	CLIMATE CONTROLLED SEAT UNIT : Disassembly and Assembly	114	A
HEATED SEAT SWITCH INDICATOR DOES NOT TURN ON	94	REAR SEAT	116	B
Diagnosis Procedure	94	Exploded View	116	
SQUEAK AND RATTLE TROUBLE DIAGNOSES	95	Removal and Installation	117	C
Work Flow	95	Disassembly and Assembly	117	
Inspection Procedure	97	POWER SEAT SWITCH	119	D
Diagnostic Worksheet	99	Exploded View	119	
REMOVAL AND INSTALLATION	101	Removal and Installation	119	D
FRONT SEAT	101	HEATED SEAT SWITCH	120	E
Exploded View	101	Exploded View	120	
Removal and Installation	108	Removal and Installation	120	E
SEATBACK	109	CLIMATE CONTROLLED SEAT SWITCH	121	F
SEATBACK : Disassembly and Assembly	109	Exploded View	121	
SEAT CUSHION	111	Removal and Installation	121	F
SEAT CUSHION : Disassembly and Assembly ...	111	CLIMATE CONTROLLED SEAT BLOWER FILTER	122	G
		Exploded View	122	
		Removal and Installation	122	H

SE

K
L
M
N
O
P

PRECAUTIONS

< PRECAUTION >

PRECAUTION

PRECAUTIONS

Precaution for Supplemental Restraint System (SRS) "AIR BAG" and "SEAT BELT PRE-TENSIONER"

INFOID:000000005986745

The Supplemental Restraint System such as "AIR BAG" and "SEAT BELT PRE-TENSIONER", used along with a front seat belt, helps to reduce the risk or severity of injury to the driver and front passenger for certain types of collision. This system includes seat belt switch inputs and dual stage front air bag modules. The SRS system uses the seat belt switches to determine the front air bag deployment, and may only deploy one front air bag, depending on the severity of a collision and whether the front occupants are belted or unbelted. Information necessary to service the system safely is included in the "SRS AIR BAG" and "SEAT BELT" of this Service Manual.

WARNING:

- To avoid rendering the SRS inoperative, which could increase the risk of personal injury or death in the event of a collision that would result in air bag inflation, all maintenance must be performed by an authorized NISSAN/INFINITI dealer.
- Improper maintenance, including incorrect removal and installation of the SRS, can lead to personal injury caused by unintentional activation of the system. For removal of Spiral Cable and Air Bag Module, see the "SRS AIR BAG".
- Do not use electrical test equipment on any circuit related to the SRS unless instructed to in this Service Manual. SRS wiring harnesses can be identified by yellow and/or orange harnesses or harness connectors.

PRECAUTIONS WHEN USING POWER TOOLS (AIR OR ELECTRIC) AND HAMMERS

WARNING:

- When working near the Air Bag Diagnosis Sensor Unit or other Air Bag System sensors with the ignition ON or engine running, DO NOT use air or electric power tools or strike near the sensor(s) with a hammer. Heavy vibration could activate the sensor(s) and deploy the air bag(s), possibly causing serious injury.
- When using air or electric power tools or hammers, always switch the ignition OFF, disconnect the battery, and wait at least 3 minutes before performing any service.

Precaution Necessary for Steering Wheel Rotation after Battery Disconnect

INFOID:000000005986746

NOTE:

- Before removing and installing any control units, first turn the push-button ignition switch to the LOCK position, then disconnect both battery cables.
- After finishing work, confirm that all control unit connectors are connected properly, then re-connect both battery cables.
- Always use CONSULT-III to perform self-diagnosis as a part of each function inspection after finishing work. If a DTC is detected, perform trouble diagnosis according to self-diagnosis results.

For vehicle with steering lock unit, if the battery is disconnected or discharged, the steering wheel will lock and cannot be turned.

If turning the steering wheel is required with the battery disconnected or discharged, follow the operation procedure below before starting the repair operation.

OPERATION PROCEDURE

1. Connect both battery cables.

NOTE:

Supply power using jumper cables if battery is discharged.

2. Turn the push-button ignition switch to ACC position.
(At this time, the steering lock will be released.)
3. Disconnect both battery cables. The steering lock will remain released with both battery cables disconnected and the steering wheel can be turned.
4. Perform the necessary repair operation.

PRECAUTIONS

< PRECAUTION >

5. When the repair work is completed, re-connect both battery cables. With the brake pedal released, turn the push-button ignition switch from ACC position to ON position, then to LOCK position. (The steering wheel will lock when the push-button ignition switch is turned to LOCK position.)
6. Perform self-diagnosis check of all control units using CONSULT-III.

Service Notice

INFOID:000000005986747

- When removing or installing various parts, place a cloth or padding onto the vehicle body to prevent scratches.
- Handle trim, molding, instruments, grille, etc. carefully during removing or installing. Be careful not to oil or damage them.
- Apply sealing compound where necessary when installing parts.
- When applying sealing compound, be careful that the sealing compound does not protrude from parts.
- When replacing any metal parts (for example body outer panel, members, etc.), be sure to take rust prevention measures.

Precaution for Work

INFOID:000000005986748

- When removing or disassembling each component, be careful not to damage or deform it. If a component may be subject to interference, be sure to protect it with a shop cloth.
- When removing (disengaging) components with a screwdriver or similar tool, be sure to wrap the component with a shop cloth or vinyl tape to protect it.
- Protect the removed parts with a shop cloth and keep them.
- Replace a deformed or damaged clip.
- If a part is specified as a non-reusable part, always replace it with new one.
- Be sure to tighten bolts and nuts securely to the specified torque.
- After re-installation is completed, be sure to check that each part works normally.
- Follow the steps below to clean components.
 - Water soluble foul: Dip a soft cloth into lukewarm water, and wring the water out of the cloth to wipe the fouled area.
Then rub with a soft and dry cloth.
 - Oily foul: Dip a soft cloth into lukewarm water with mild detergent (concentration: within 2 to 3%), and wipe the fouled area.
Then dip a cloth into fresh water, and wring the water out of the cloth to wipe the detergent off. Then rub with a soft and dry cloth.
- Never use organic solvent such as thinner, benzene, alcohol, and gasoline.
- For genuine leather seats, use a genuine leather seat cleaner.

PREPARATION

< PREPARATION >

PREPARATION

PREPARATION

Special Service Tool

INFOID:000000005986749

The actual shapes of Kent-Moore tools may differ from those of special service tools illustrated here.

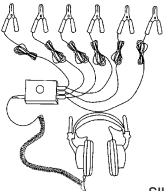
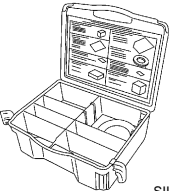
Tool number (Kent-Moore No.) Tool name	Description
<p>(J39570) Chassis ear</p>  <p style="text-align: right;">SIIA0993E</p>	<p>Locates the noise</p>
<p>(J43980) NISSAN Squeak and Rattle Kit</p>  <p style="text-align: right;">SIIA0994E</p>	<p>Repairs the cause of noise</p>

Commercial Service Tool

INFOID:000000005986750

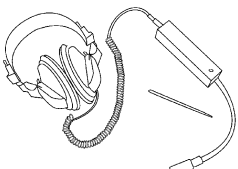
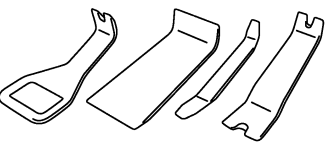
Tool name	Description
<p>Engine ear</p>  <p style="text-align: right;">SIIA0995E</p>	<p>Locates the noise</p>
<p>Remover tool</p>  <p style="text-align: right;">PIIB7923J</p>	<p>Removes clips, pawls and metal clips</p>

CLIP LIST

< PREPARATION >

CLIP LIST

Clip List

INFOID:000000006046716

Shapes	Removal & Installation	Shapes	Removal & Installation
	<p>Removal: Remove by bending up with flat-bladed screwdrivers or clip remover.</p>		<p>Removal:</p>
	<p>Removal: Remove with a clip remover.</p>		<p>Removal:</p>
	<p>Removal: Push center pin to catching position. (Do not remove center pin by hitting it.)</p> <p>Installation:</p>		<p>Removal: Holder portion of clip must be spread out to remove rod.</p>
	<p>Removal: Remove by bending up with flat-bladed screwdrivers or clip remover.</p>		<p>Removal:</p> <ol style="list-style-type: none"> Screw out with a Phillips screwdriver. Remove female portion with flat-bladed screwdriver.
	<p>Removal:</p>		<p>Removal:</p> <p>Rotate 45° to remove.</p> <p>Installation:</p>
	<p>Removal:</p>		<p>Removal:</p>

JMJIA3734GB

A
B
C
D
E
F
G
H
I
SE
K
L
M
N
O
P

COMPONENT PARTS

< SYSTEM DESCRIPTION >

SYSTEM DESCRIPTION

COMPONENT PARTS

POWER SEAT SYSTEM

POWER SEAT SYSTEM : Component Parts Location

INFOID:000000006138010

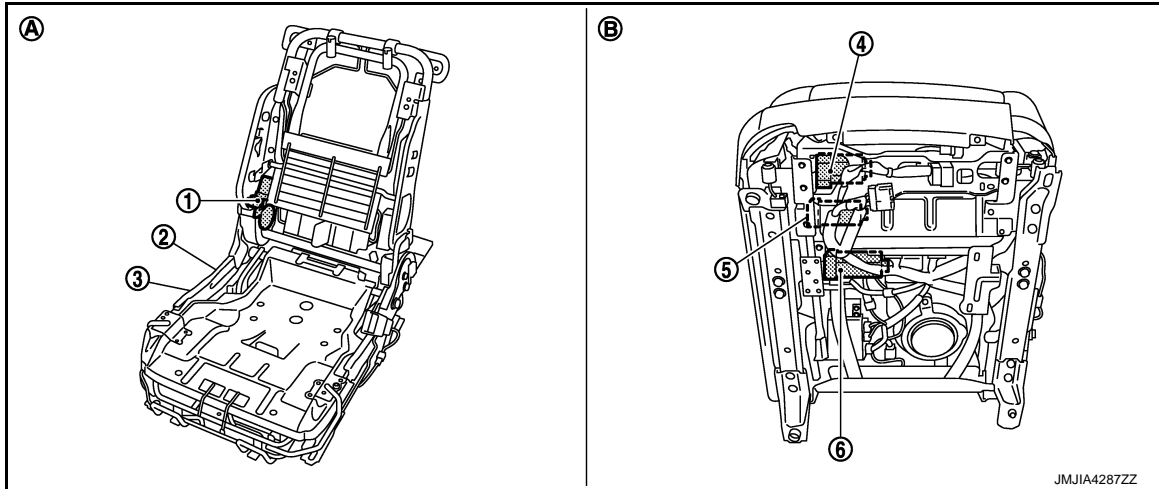

- | | | |
|---|------------------------------|----------------------------------|
| 1. Reclining motor | 2. Reclining switch | 3. Lifting switch/sliding switch |
| 4. Sliding motor | 5. Lifting motor (front) | 6. Lifting motor (rear) |
| A. View with seat cushion pad and seat back pad are removed | B. Back side of seat cushion | |

POWER SEAT SYSTEM : Component Description

INFOID:000000006138011

Item	Function
BCM	Supplies at all times the power received from battery to power seat switch.
Power seat switch	Built-in reclining switch, sliding switch and lifting switch, controls the power supplied to each motor.
Reclining motor	With the power supplied from power seat switch, operates the forward and backward movement of seatback.
Sliding motor	With the power supplied from power seat switch, operates the forward and backward slide of seat.
Lifting motor (front/rear)	With the power supplied from power seat switch, operates the up and down movement of seat cushion.

LUMBAR SUPPORT SYSTEM

COMPONENT PARTS

< SYSTEM DESCRIPTION >

LUMBAR SUPPORT SYSTEM : Component Parts Location

INFOID:000000005986760

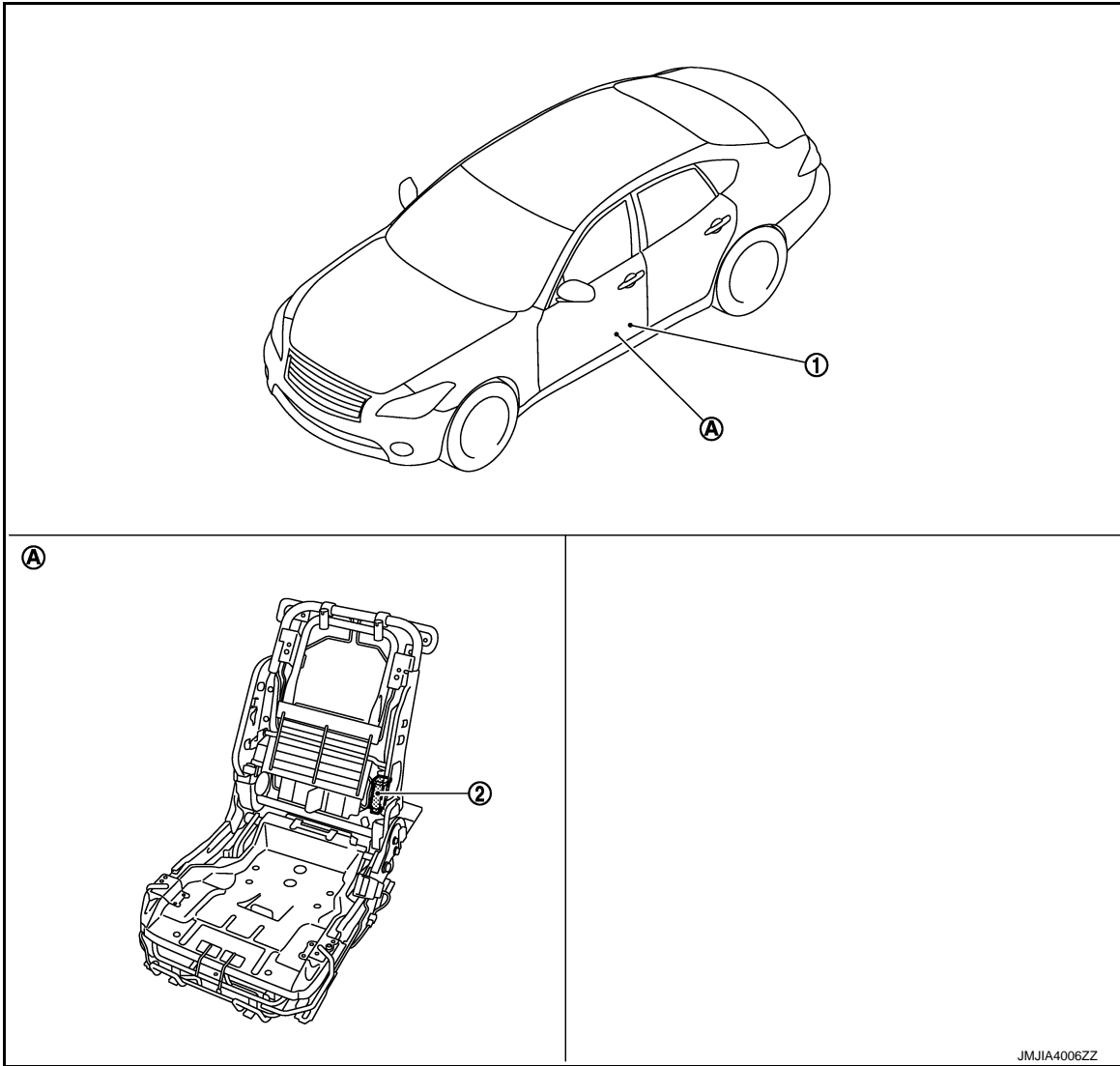

- 1. Lumbar support switch
- 2. Lumbar support motor
- A. View with seatback pad is removed

LUMBAR SUPPORT SYSTEM : Component Description

INFOID:000000005986761

Item	Function
Lumbar support switch	Controls the power supplied to lumbar support motor.
Lumbar support motor	With the power supplied from lumbar support switch, operates forward and backward movement of seatback support unit.

CLIMATE CONTROLLED SEAT SYSTEM

A
B
C
D
E
F
G
H
I
SE
K
L
M
N
O
P

COMPONENT PARTS

< SYSTEM DESCRIPTION >

CLIMATE CONTROLLED SEAT SYSTEM : Component Parts Location

INFOID:000000005986764

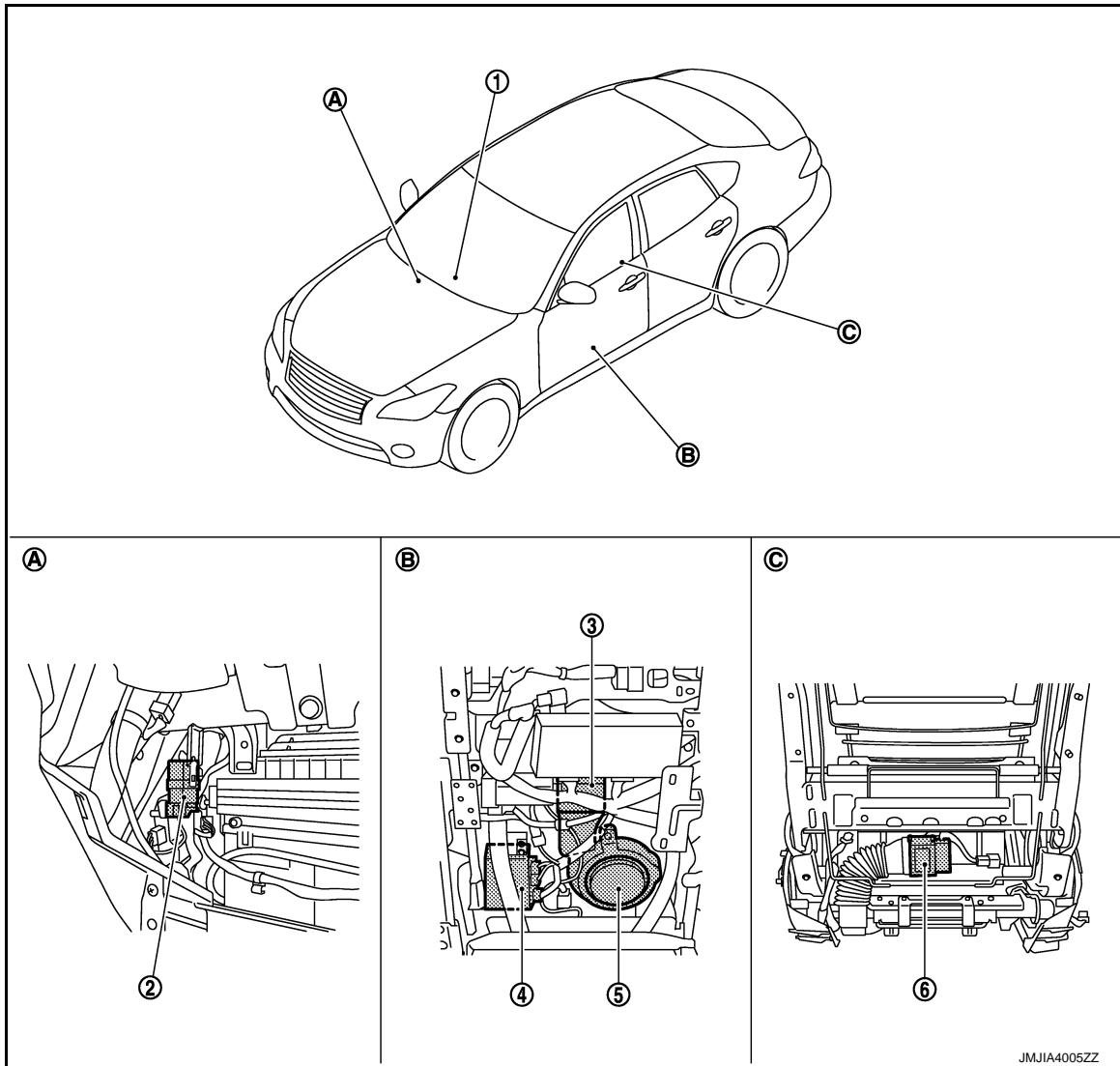

- | | | |
|--|---|---------------------------------------|
| 1. Climate controlled seat switch | 2. Climate controlled seat relay | 3. Seat cushion thermal electric unit |
| 4. Climate controlled seat control unit | 5. Climate controlled seat cushion blower motor | 6. Seatback thermal electric unit |
| A. View with instrument lower panel RH removed | B. Backside of seat cushion | C. View with seatback board removed |

CLIMATE CONTROLLED SEAT SYSTEM : Component Description

INFOID:000000005986765

Item	Function
Climate controlled seat relay	Supplies power to the climate controlled seat control unit in accordance with the key switch position that is ON or START.
Climate controlled seat control unit	Installed in the seat cushion backside and controls the seat cushion blower motor, seatback thermal electric unit, and seat cushion thermal electric unit in accordance with the input signal.
Climate controlled seat switch	Installed in the center console and transmits signals to climate controlled seat control unit in accordance with the HEAT (heated airflow) or COOL (cooled airflow) switch operation and the temperature switch operation.

COMPONENT PARTS

< SYSTEM DESCRIPTION >

Item	Function
Seat cushion blower motor	Installed in the seat cushion backside and sends the airflow to the seat cushion thermal electric unit in accordance with the control from the climate controlled seat control unit.
Seatback thermal electric unit	Installed in the seatback backside and heats or cools the airflow from the climate controlled seat blower motor in accordance with the control from the climate controlled seat control unit.
Seat cushion thermal electric unit	Installed in the seat cushion backside and heats or cools the airflow from the climate controlled seat blower motor in accordance with the control from the climate controlled seat control unit.
Seatback thermal electric unit sensor	Measures seatback temperature.
Seat cushion thermal electric unit sensor	Measures seat cushion temperature.
Climate controlled seat switch indicator	Turn ON the indicator that indicates the operating status of climate controlled seat HEAT or COOL mode.

HEATED SEAT SYSTEM

HEATED SEAT SYSTEM : Component Parts Location

INFOID:000000005986757

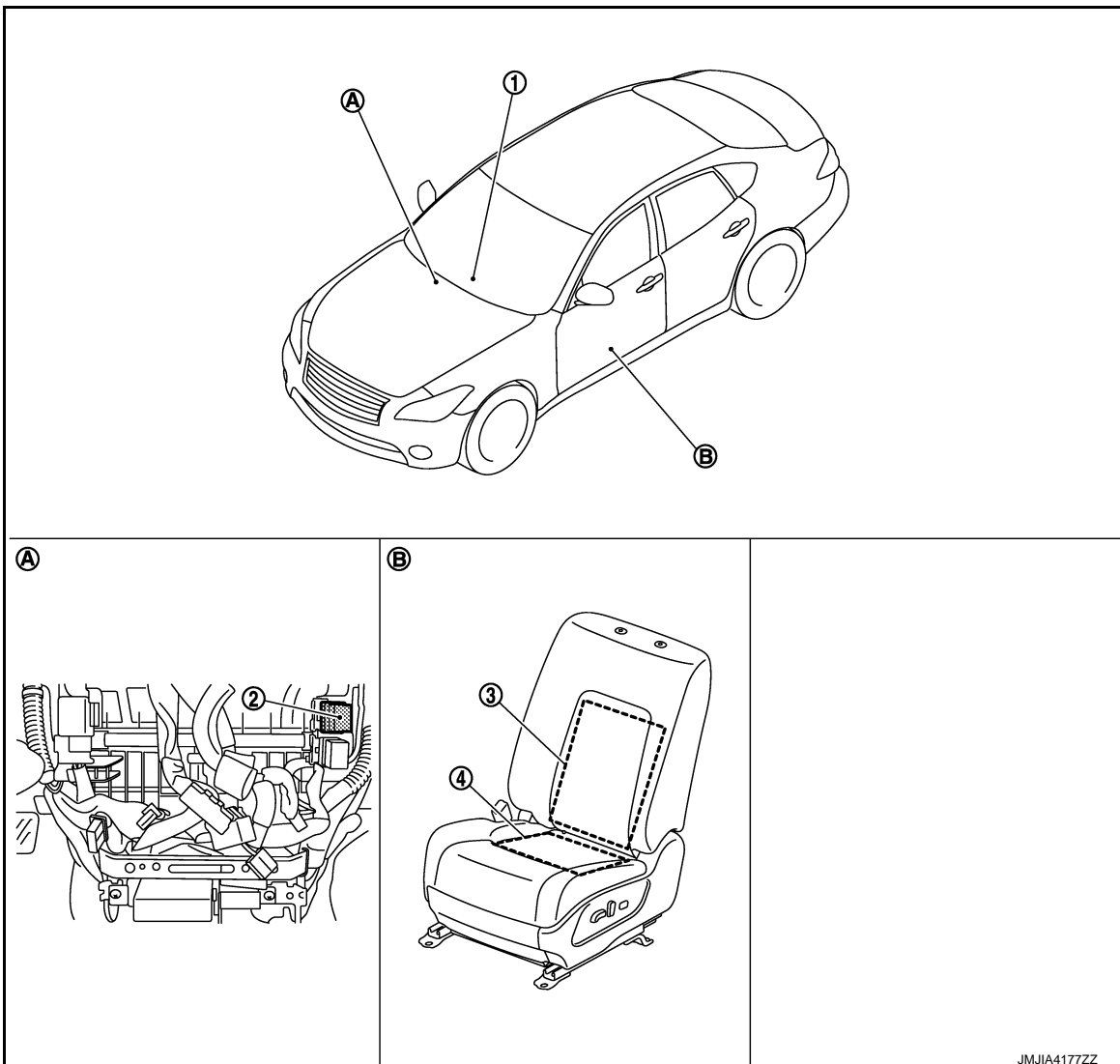

1. Heated seat switch

2. Heated seat relay

3. Seatback heater

COMPONENT PARTS

< SYSTEM DESCRIPTION >

4. Seat cushion heater (built-in heated seat control unit)
- A. View with cluster lid C removed B. Inside of front seat

HEATED SEAT SYSTEM : Component Description

INFOID:000000005986758

Item	Function
Heated seat control unit	<ul style="list-style-type: none">• Heated seat control unit is integrated in seat cushion heater.• Controls heated seat temperature and is independently placed in each seat cushion (driver seat and passenger seat).
Heated seat switch	<ul style="list-style-type: none">• Adjusts heated seat temperature and deactivates heated seat.• Equips indicator that indicates the operating condition.
Seat cushion heater	<ul style="list-style-type: none">• Warms seat cushion.• Contains heat sensor that outputs seat cushion heater temperature to heated seat control unit.
Seatback heater	Warms seatback.
Heated seat relay	Supplies power to the heated seat being controlled by ignition power supply.

SYSTEM

< SYSTEM DESCRIPTION >

SYSTEM

POWER SEAT SYSTEM

POWER SEAT SYSTEM : System Description

INFOID:000000006138012

Power seat switch can be operated regardless of the ignition switch position, because power supply is always supplied to power seat switch.

SLIDING OPERATION

While operating the sliding switch located in power seat switch, sliding motor operates and makes possible the seat front and back position adjustment.

RECLINING OPERATION

While operating the reclining switch located in power seat switch, reclining motor operates and makes possible the seat back forward and backward position adjustment.

LIFTING OPERATION

While operating the lifting switch located in power seat switch, lifting motor operates and makes possible the seat cushion up and down position adjustment.

LUMBAR SUPPORT SYSTEM

LUMBAR SUPPORT SYSTEM : System Description

INFOID:0000000005986759

- Lumbar support can operate regardless of the ignition switch position because battery power is supplied to it at all times.
- While operating the lumbar support switch, lumbar support motor operates which allows forward and backward operation of seatback support.

CLIMATE CONTROLLED SEAT SYSTEM

CLIMATE CONTROLLED SEAT SYSTEM : System Diagram

INFOID:0000000005986766

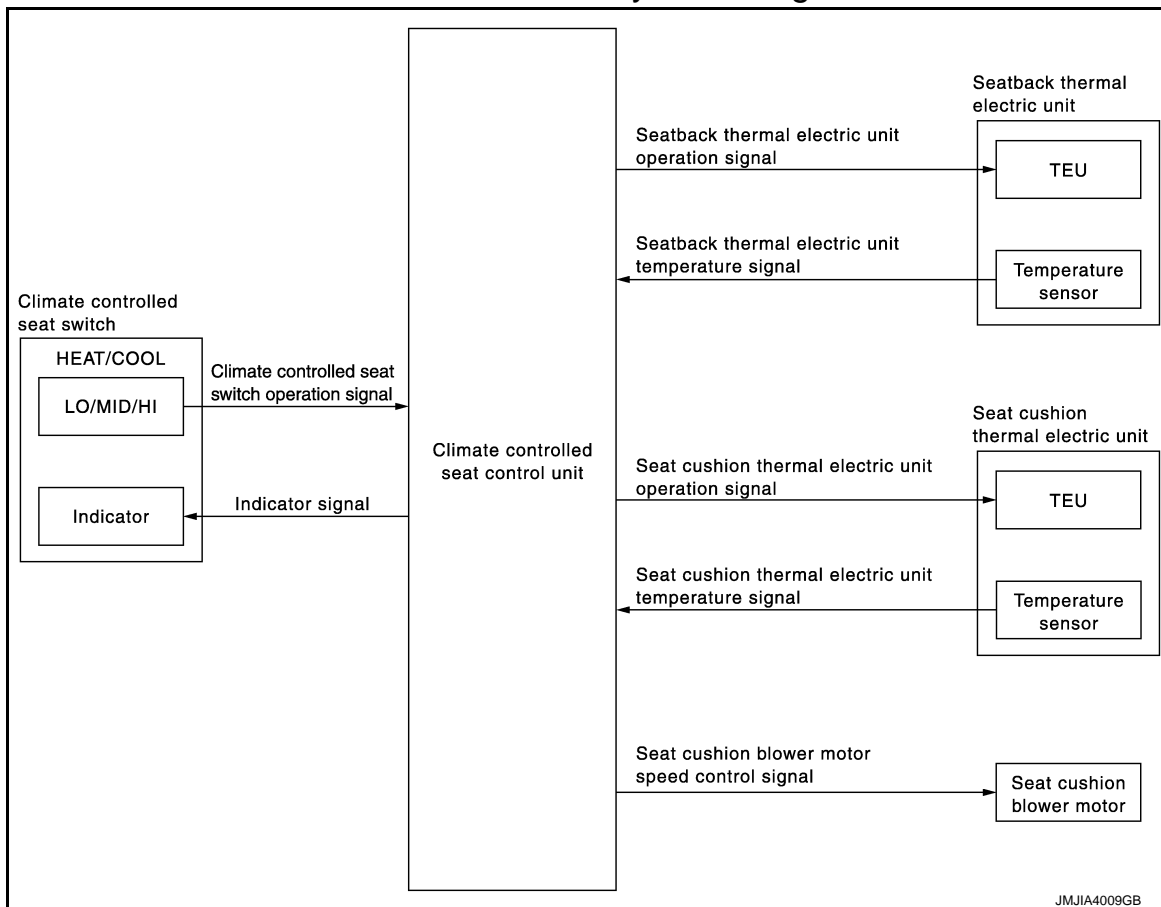

A
B
C
D
E
F
G
H
I

SE

K
L
M
N
O
P

SYSTEM

< SYSTEM DESCRIPTION >

CLIMATE CONTROLLED SEAT SYSTEM : System Description

INFOID:000000005986767

- The climate controlled seat system is controlled by the climate controlled seat control unit.
- Operation of the climate controlled switch sends heated or cooled airflow and adjusts the seat temperature.

SEAT CUSHION AND SEATBACK TEMPERATURE ADJUSTMENT FUNCTION

- One thermal electric unit is installed in each seat cushion and seatback. The unit heats or cools, sends airflow to the seat surface, and adjusts the seat temperature.
- The thermal electric unit is a heat exchanger that has a function to heat or cool the airflow from the seat cushion blower motor. By changing the direction of the current from the power supply, the unit takes or gives heat, and adjusts exchange process depending on voltage.

CAUTION:

- **The thermal electric unit has a dual-climate function that allows one side to operate at a high temperature and the other to operate at a low temperature simultaneously.**
- **Before starting always turn OFF the switch and check that the electric unit is cold.**

FAIL-SAFE

The fail-safe function is adopted for the climate controlled seat control to [SE-14, "CLIMATE CONTROLLED SEAT SYSTEM : Fail-safe"](#).

CLIMATE CONTROLLED SEAT SYSTEM : Fail-safe

INFOID:000000005987198

- Climate controlled seat control unit equips fail-safe function.
- When a malfunction occurs in the systems shown below, climate controlled seat control unit stops output.

Malfunction	Malfunctioning condition
The temperature difference between the seatback thermal electric unit and seat cushion thermal electric unit is more than 40°C	<ul style="list-style-type: none"> • When it detects for 4 seconds that the temperature difference between the seatback thermal electric unit and seat cushion thermal electric unit is more than 40°, it stops the output to the thermal electric unit, activates the climate controlled seat blower motor at the maximum position, and sends the external airflow for 30 seconds. • If the temperature difference is still more than 40°C after 30 seconds pass, it stops all output and enters the system OFF condition. • When the temperature difference between seatback thermal electric unit and seat cushion thermal electric unit becomes less than 20°C, the system recovers automatically. • If it detects that the temperature difference is more than 40°C after the automatic system recovery, it immediately stops all output and enters the system OFF condition. <p>NOTE: When the switch operation is performed before entering the system OFF condition, the fail-safe mode is reset.</p>
The temperature of thermal electric unit is more than 110°C in the HEAT mode (any thermal electric unit in the seatback or seat cushion)	<ul style="list-style-type: none"> • When it detects for 4 seconds that the temperature of the thermal electric unit is more than 110°C, it stops the output to the thermal electric unit, activates the climate controlled seat blower motor at the maximum position, and sends the external airflow for 30 seconds. • If the temperature does not become less than 105°C after 30 seconds pass, it stops all output and enters the system OFF condition. • When the temperature of the thermal electric unit becomes less than 105°C, the system recovers automatically. • If it detects that the temperature of the thermal electric unit is more than 110°C after the automatic system recovery, it immediately stops all output and enters the system OFF condition.
The temperature of the thermal electric unit is more than 45°C in the COOL mode (any thermal electric unit in the seatback or seat cushion)	<ul style="list-style-type: none"> • When it detects for 4 seconds that the temperature of the thermal electric unit is more than 45°C and less than 70°C, it starts the temperature monitoring of the thermal electric unit at 3 second intervals. • While monitoring, if it detects that the temperature continuously rises 2°C or more 4 times or reaches 70°C or more, it stops all output and enters the system OFF condition. • If it detects other results of monitoring, it continues activating in the COOL mode.
Thermal electric unit sensor open circuit (in either the back and the cushion)	<ul style="list-style-type: none"> • When it detects for 4 seconds that the thermal electric unit sensor is an open circuit, it stops all output and enters the system OFF condition.

SYSTEM

< SYSTEM DESCRIPTION >

Malfunction	Malfunctioning condition
Climate controlled seat blower motor system open circuit (in the cushion blower)	<ul style="list-style-type: none"> • When it detects for 2 seconds that climate controlled seat blower motor is an open circuit while the climate controlled seat is being activated, and the battery status has been stable for the same 2 second period, it stops output to the thermal electric unit. • When it detects for 10 seconds that the climate controlled seat blower motor is an open circuit while the climate controlled seat is being activated, and the battery status has been stable for the same 10second period, it stops all output and enters the system OFF condition. <p>NOTE: After detecting the climate seat blower motor system open circuit for 2 seconds, the system recovers automatically if the activation of the climate controlled seat blower motor is detected for 1 second or more.</p>
Switch input out of the specified range (either heat input or cool input)	<ul style="list-style-type: none"> • When it detects for 4 seconds that the rotary switch input is less than 30% of the vehicle battery voltage, it stops all output and enters the system OFF condition. • When the switch input returns to a value within the specified range, the system recovers automatically.
HEAT or COOL switch input out of the specified range	<ul style="list-style-type: none"> • During the standby mode, heating or cooling states, if the rotary switch input is 6% or less of the vehicle battery voltage, it stops all output and enters the system OFF condition. • When the switch input returns to a value within the specified range, the system recovers automatically.
System voltage out of range	<ul style="list-style-type: none"> • If the system voltage at the climate controlled seat control unit falls outside of the 8.5 to 16.5 V operating range, it stops all output after a 500ms time period. • When the system voltage returns to the normal operating range (10.5-15.5V with a 500ms hysteresis), the system recovers automatically.

*: System voltage is the voltage between the climate controlled seat control unit power source and ground.

NOTE:

When the ignition status changes to OFF during the fail-safe mode, the control unit shall enter the OFF condition. If the ignition is turned ON, the system shall return to the standby mode. If the system enters in the fail-safe mode again after performing ignition cycle, start the diagnosis.

HEATED SEAT SYSTEM

A
B
C
D
E
F
G
H
I
SE
K
L
M
N
O
P

SYSTEM

< SYSTEM DESCRIPTION >

HEATED SEAT SYSTEM : System Diagram

INFOID:000000005986755

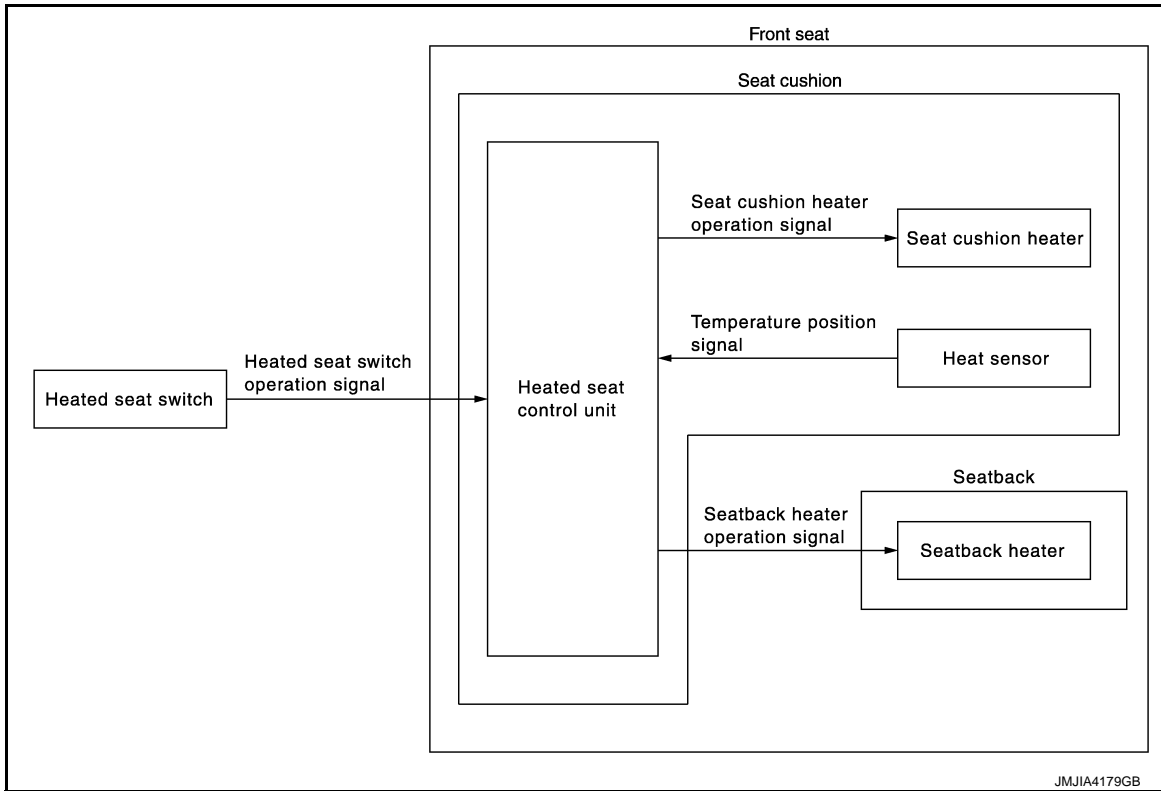

HEATED SEAT SYSTEM : System Description

INFOID:000000005986756

- Heated seat is activated by heated seat switch while ignition switch is ON, and has the function to warm seat cushion and seatback.
- Heated seat equips the 6-stage temperature adjustment function that adjusts temperature by operating heated seat switch to the optimal position.
- Heated seat equips a thermostat in heater unit to prevent heater unit overheating.

OPERATION DESCRIPTION

- When operating heated seat switch to any position between 1 and 6 while ignition switch is ON, indicator illuminates, heated seat control unit controls heater unit, and warms seat cushion and seatback.
- Heat sensor that is built in seat cushion heater detects seat cushion heater temperature and outputs to heated seat control unit.
- Heated seat control unit monitors heated seat switch position and heat sensor temperature, and interrupts ground circuit to heater unit when heat sensor temperature reaches preset temperature.
- Heated seat control unit adjusts temperature to preset temperature by interrupting ground circuit to heater unit.

CLIMATE CONTROLLED SEAT CONTROL UNIT

< ECU DIAGNOSIS INFORMATION >

ECU DIAGNOSIS INFORMATION

CLIMATE CONTROLLED SEAT CONTROL UNIT

Reference Value

INFOID:000000006022803

TERMINAL LAYOUT

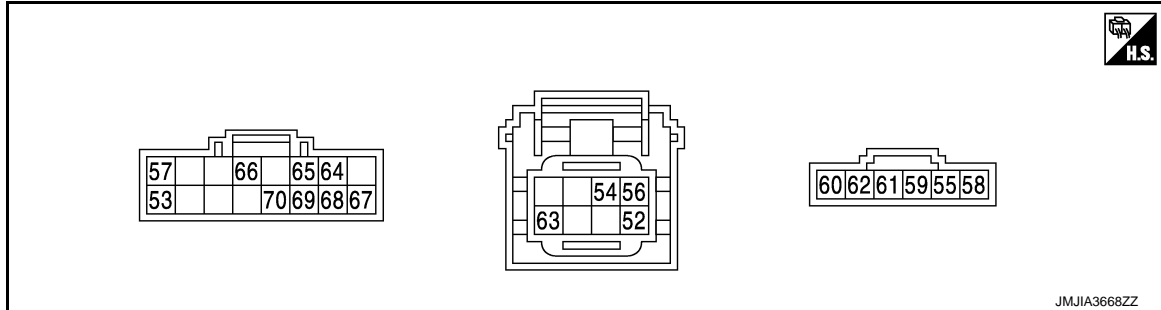

PHYSICAL VALUES

Terminal No. (Wire color)		Description		Condition	Voltage (V) (Approx.)
+	-	Signal name	Input/ Output		
52 (L/B)	Ground	Climate controlled seat switch power supply	Output	Ignition switch ON	12
53 (Y/W)	Ground	COOL switch indicator signal	Output	Climate controlled seat switch	COOL 12 Other than the above 0
54 (Y)	Ground	HEAT switch signal	Input	Climate controlled seat switch	HEAT HI 2.6 - 4.2 MID 1.6 - 2.5 LO 0.8 - 1.5 OFF 0
55 (G/R)	Ground	Ignition switch power supply	Input	Ignition switch ON	Battery voltage
56 (V)	Ground	COOL switch signal	Input	Climate controlled seat switch	COOL HI 2.6 - 4.2 MID 1.6 - 2.5 LO 0.8 - 1.5 OFF 0
57 (B/P)	Ground	HEAT switch indicator signal	Output	Climate controlled seat switch	HEAT 12 Other than the above 0
58 (B)	Ground	Ground	—	—	0
59 (LG/R)	Ground	Seatback thermal electric unit HEAT signal	Output	Climate controlled seat switch	HEAT or COOL 0 - 12° OFF 0
60 (LG/B)	Ground	Seatback thermal electric unit COOL signal	Output	Climate controlled seat switch	HEAT or COOL 0 - 12° OFF 0
61 (Y/R)	Ground	Seat cushion thermal electric unit HEAT signal	Output	Climate controlled seat switch	HEAT or COOL 0 - 12° OFF 0
62 (B/R)	Ground	Seat cushion thermal electric unit COOL signal	Output	Climate controlled seat switch	HEAT or COOL 0 - 12° OFF 0

CLIMATE CONTROLLED SEAT CONTROL UNIT

< ECU DIAGNOSIS INFORMATION >

63 (R)	Ground	Ignition switch power supply	Input	Ignition switch ON	Battery voltage		
64 (W/R)	Ground	Seat cushion blower motor power supply	Output	Climate controlled seat switch	HEAT or COOL	12	
				Other than the above		0	
65 (W/B)	Ground	Seat cushion blower motor ground	—	—	0		
66 (Y/G)	Ground	Seat cushion blower motor speed control signal	Output	Climate controlled seat switch	HEAT		6.5 - 8
					COOL	HI	10
						MID	8
						LO	6
67 (L/R)	Ground	Seatback thermal electric unit sensor ground	—	Ignition switch ON	0		
68 (L)	Ground	Seatback thermal electric unit sensor signal	Input	Climate controlled seat operated	1 - 5		
69 (G/B)	Ground	Seat cushion thermal electric unit sensor ground	—	Ignition switch ON	0		
70 (G/W)	Ground	Seat cushion thermal electric unit sensor signal	Input	Climate controlled seat operated	1 - 5		

* : It value changes between 12 V and 0 V.

NOTE:

- Measure the value on the condition that the battery voltage is 14 V.
- Wait 1 minute or more after thermal electric unit is activated, and then start the measurement.

Fail-safe

INFOID:000000005987199

- Climate controlled seat control unit equips fail-safe function.
- When a malfunction occurs in the systems shown below, climate controlled seat control unit stops output.

Malfunction	Malfunctioning condition
<p>The temperature difference between the seatback thermal electric unit and seat cushion thermal electric unit is more than 40°C</p>	<ul style="list-style-type: none"> • When it detects for 4 seconds that the temperature difference between the seatback thermal electric unit and seat cushion thermal electric unit is more than 40°, it stops the output to the thermal electric unit, activates the climate controlled seat blower motor at the maximum position, and sends the external airflow for 30 seconds. • If the temperature difference is still more than 40°C after 30 seconds pass, it stops all output and enters the system OFF condition. • When the temperature difference between seatback thermal electric unit and seat cushion thermal electric unit becomes less than 20°C, the system recovers automatically. • If it detects that the temperature difference is more than 40°C after the automatic system recovery, it immediately stops all output and enters the system OFF condition. <p>NOTE: When the switch operation is performed before entering the system OFF condition, the fail-safe mode is reset.</p>
<p>The temperature of thermal electric unit is more than 110°C in the HEAT mode (any thermal electric unit in the seatback or seat cushion)</p>	<ul style="list-style-type: none"> • When it detects for 4 seconds that the temperature of the thermal electric unit is more than 110°C, it stops the output to the thermal electric unit, activates the climate controlled seat blower motor at the maximum position, and sends the external airflow for 30 seconds. • If the temperature does not become less than 105°C after 30 seconds pass, it stops all output and enters the system OFF condition. • When the temperature of the thermal electric unit becomes less than 105°C, the system recovers automatically. • If it detects that the temperature of the thermal electric unit is more than 110°C after the automatic system recovery, it immediately stops all output and enters the system OFF condition.

CLIMATE CONTROLLED SEAT CONTROL UNIT

< ECU DIAGNOSIS INFORMATION >

Malfunction	Malfunctioning condition
The temperature of the thermal electric unit is more than 45°C in the COOL mode (any thermal electric unit in the seatback or seat cushion)	<ul style="list-style-type: none"> When it detects for 4 seconds that the temperature of the thermal electric unit is more than 45°C and less than 70°C, it starts the temperature monitoring of the thermal electric unit at 3 second intervals. While monitoring, if it detects that the temperature continuously rises 2°C or more 4 times or reaches 70°C or more, it stops all output and enters the system OFF condition. If it detects other results of monitoring, it continues activating in the COOL mode.
Thermal electric unit sensor open circuit (in either the back and the cushion)	<ul style="list-style-type: none"> When it detects for 4 seconds that the thermal electric unit sensor is an open circuit, it stops all output and enters the system OFF condition.
Climate controlled seat blower motor system open circuit (in the cushion blower)	<ul style="list-style-type: none"> When it detects for 2 seconds that climate controlled seat blower motor is an open circuit while the climate controlled seat is being activated, and the battery status has been stable for the same 2 second period, it stops output to the thermal electric unit. When it detects for 10 seconds that the climate controlled seat blower motor is an open circuit while the climate controlled seat is being activated, and the battery status has been stable for the same 10second period, it stops all output and enters the system OFF condition. <p>NOTE: After detecting the climate seat blower motor system open circuit for 2 seconds, the system recovers automatically if the activation of the climate controlled seat blower motor is detected for 1 second or more.</p>
Switch input out of the specified range (either heat input or cool input)	<ul style="list-style-type: none"> When it detects for 4 seconds that the rotary switch input is less than 30% of the vehicle battery voltage, it stops all output and enters the system OFF condition. When the switch input returns to a value within the specified range, the system recovers automatically.
HEAT or COOL switch input out of the specified range	<ul style="list-style-type: none"> During the standby mode, heating or cooling states, if the rotary switch input is 6% or less of the vehicle battery voltage, it stops all output and enters the system OFF condition. When the switch input returns to a value within the specified range, the system recovers automatically.
System voltage out of range	<ul style="list-style-type: none"> If the system voltage at the climate controlled seat control unit falls outside of the 8.5 to 16.5 V operating range, it stops all output after a 500ms time period. When the system voltage returns to the normal operating range (10.5-15.5V with a 500ms hysteresis), the system recovers automatically.

*: System voltage is the voltage between the climate controlled seat control unit power source and ground.

NOTE:

When the ignition status changes to OFF during the fail-safe mode, the control unit shall enter the OFF condition. If the ignition is turned ON, the system shall return to the standby mode. If the system enters in the fail-safe mode again after performing ignition cycle, start the diagnosis.

A
B
C
D
E
F
G
H
I
SE
K
L
M
N
O
P

HEATED SEAT CONTROL UNIT (DRIVER SIDE)

< ECU DIAGNOSIS INFORMATION >

HEATED SEAT CONTROL UNIT (DRIVER SIDE)

Reference Value

INFOID:000000006067413

TERMINAL LAYOUT

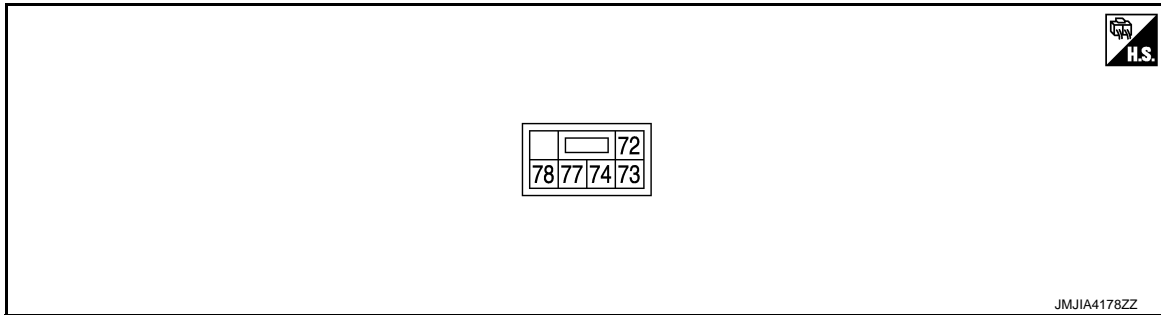

PHYSICAL VALUES

Terminal No. (Wire color)		Description		Condition		Voltage (V) (Approx.)
+	-	Signal name	Input/ Output			
72 (LG/B)	Ground	Heated seat switch signal	Input	Heated seat switch	OFF	0
					1 (Min. temperature)	10.66 ^{*1}
					2	11.18 ^{*1}
					3	11.76 ^{*1}
					4	12.12 ^{*1}
					5	12.47 ^{*1}
					6 (Max. temperature)	12.83 ^{*1}
73 (LG/R)	Ground	Heated seat operation signal	Input	Heated seat switch	ON	Battery voltage
					OFF	0
74 (B)	Ground	Ground	—	—	—	0
77 (R)	Ground	Battery power supply	Input	Ignition switch	ON	Battery voltage
					Other than the above	0
78 (LG/Y)	Ground	Seatback heater signal	Input	Heated seat	Operated	0.48 ^{*2}

*1 : When thermistor temperature is 20°C (68°F).

*2 : Voltage changes according to temperature of seatback heater.

HEATED SEAT CONTROL UNIT (PASSENGER SIDE)

< ECU DIAGNOSIS INFORMATION >

HEATED SEAT CONTROL UNIT (PASSENGER SIDE)

Reference Value

INFOID:000000006097774

TERMINAL LAYOUT

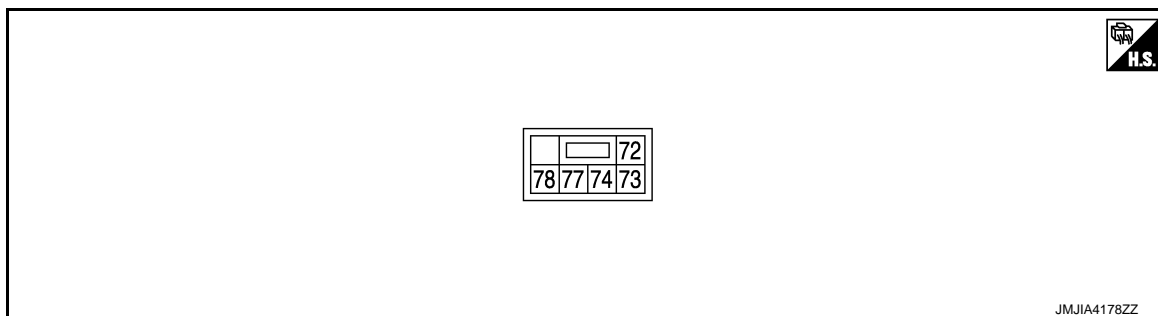

PHYSICAL VALUES

Terminal No. (Wire color)		Description		Condition		Voltage (V) (Approx.)
+	-	Signal name	Input/ Output			
72 (LG/B)	Ground	Heated seat switch signal	Input	Heated seat switch	OFF	0
					1 (Min. temperature)	10.66 ^{*1}
					2	11.18 ^{*1}
					3	11.76 ^{*1}
					4	12.12 ^{*1}
					5	12.47 ^{*1}
73 (LG/R)	Ground	Heated seat operation signal	Input	Heated seat switch	ON	Battery voltage
					OFF	0
74 (B/W)	Ground	Ground	—	—	—	0
77 (R/W)	Ground	Battery power supply	Input	Ignition switch	ON	Battery voltage
					Other than the above	0
78 (LG/Y)	Ground	Seatback heater signal	Input	Heated seat	Operated	0.48 ^{*2}

*1 : When thermistor temperature is 20°C (68°F).

*2 : Voltage changes according to temperature of seatback heater.

POWER SEAT CONTROL SYSTEM (PASSENGER SIDE)

< WIRING DIAGRAM >

WIRING DIAGRAM

POWER SEAT CONTROL SYSTEM (PASSENGER SIDE)

Wiring Diagram

INFOID:000000005986778

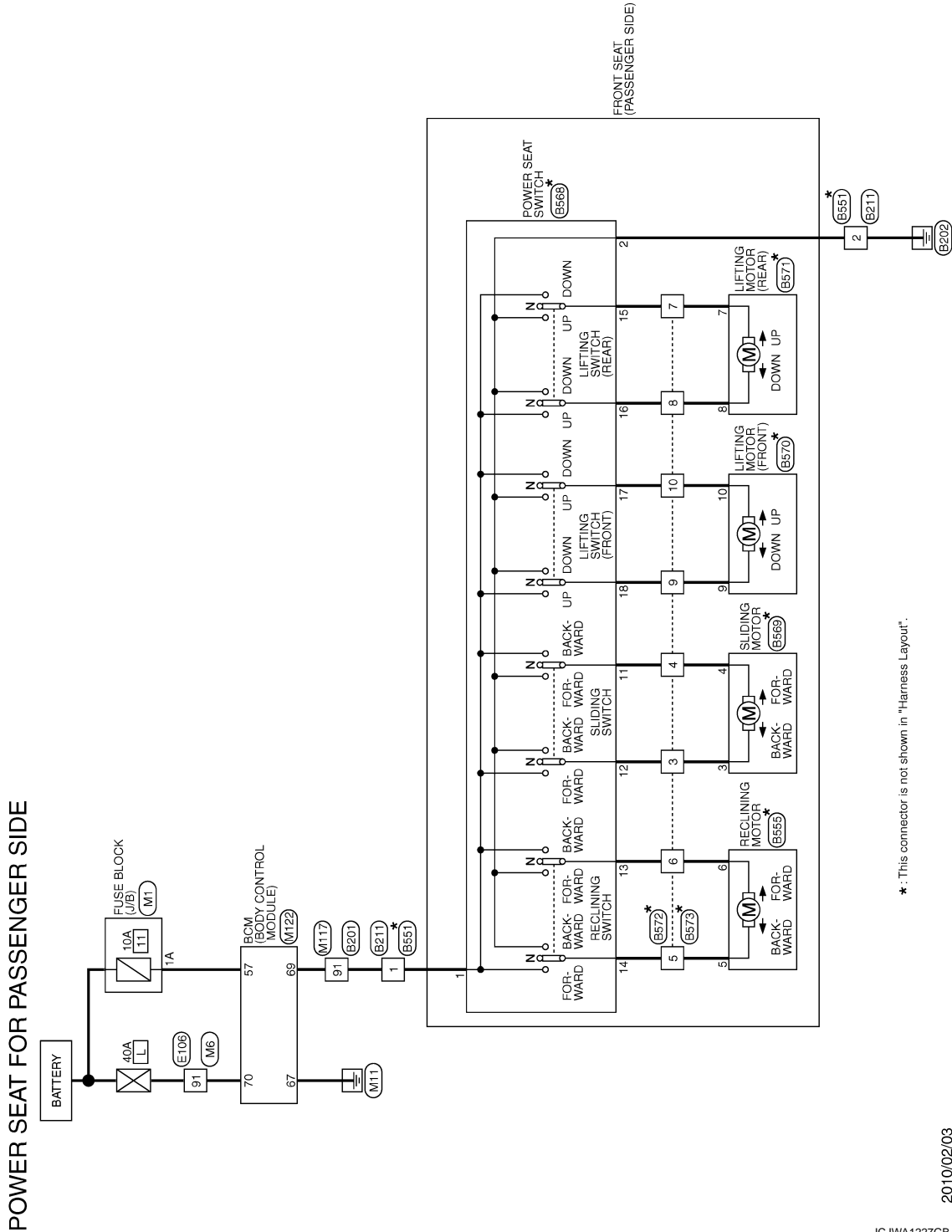

POWER SEAT CONTROL SYSTEM (PASSENGER SIDE)

< WIRING DIAGRAM >

POWER SEAT FOR PASSENGER SIDE

Connector No.	B201
Connector Name	WIRE TO WIRE
Connector Type	TK10DFV-CS16-TM4



Terminal No.	Color of Wire	Signal Name [Specification]
3	R	-
17	GR	-
18	P	-
19	BR	-
20	GR	-
21	Y	-
22	GR	-
23	R	-
24	V	-
25	B	-
26	W	-
27	W	-
28	V	-
29	P	-
30	O	-
31	B/R	-
32	Y	-
40	SHIELD	-
41	W/R	-
42	V	-
44	P	-
45	SB	-
46	R	- [With Climate controlled seat]
47	G	- [With Climate controlled seat]
47	GR	- [With Climate controlled seat]
48	V	-
49	O	-
50	R	-
51	GR	-
52	LG	-
53	P	-
56	P	-
57	W	-
58	O	-
59	V	-
61	SB	-
62	L	-

63	W	-
66	L	-
67	Y	-
68	SB	-
69	B	-
70	R	-
76	SHIELD	-
77	G	-
78	R	-
79	P	-
80	G	-
81	P	-
82	BR	-
83	GR	-
84	V	-
85	LG	-
86	W	-
87	O	-
88	Y	-
89	BR	-
90	L	-
91	BR	-
93	Y	- [With Climate controlled seat]
93	O	- [With heated seat]
94	GR	-
96	W	-
97	P	-
98	LG	-
99	LG	-
100	Y	-

Connector No.	B211
Connector Name	WIRE TO WIRE
Connector Type	TK10DFV-NS8



Terminal No.	Color of Wire	Signal Name [Specification]							
1	BR	-							
35	G	-							
40	L	-							
41	B	-							
46	Y	-							
46	47	48	35	41	40	57	49	50	34
58	L	-							
58	B/W	-							
61	B	-							
46	Y	-							

47	BR	-
48	SHIELD	-
49	L	-
50	B/W	-
52	SB	-
53	O	-
54	R	- [With Climate controlled seat]
54	B	- [With heated seat]
55	Y	-
56	G	-
57	V	-
58	B	- [With Climate controlled seat]
58	GR	- [With heated seat]

Connector No.	B51
Connector Name	WIRE TO WIRE
Connector Type	TK10DMV-NS8



Terminal No.	Color of Wire	Signal Name [Specification]
1	R	-
2	B	-
35	W/Y	-
40	W/G	-
41	GR	-
46	R	-
47	G	-
48	R/Y	-
49	P	-
50	L	-
52	L/B	-
53	Y/W	- [With Climate controlled seat]
53	R/W	- [With heated seat]
54	Y	- [With Climate controlled seat]
54	B/W	- [With heated seat]
55	G/R	- [With Climate controlled seat]
55	LG/R	- [With heated seat]
56	V	-
57	B/P	-
58	B/W	- [With Climate controlled seat]
58	LG/B	- [With heated seat]

Connector No.	B555
Connector Name	RECLINING MOTOR
Connector Type	SUMITOMO 818P-0706



Terminal No.	Color of Wire	Signal Name [Specification]
5	V	-
6	P	-

Connector No.	B568
Connector Name	POWER SEAT SWITCH
Connector Type	NS10DFV-CS



Terminal No.	Color of Wire	Signal Name [Specification]
1	R	-
2	B	-
11	G/B	-
12	G/W	-
13	R/G	-
14	R/W	-
15	Y/B	-
16	Y/R	-
17	LG/B	-
18	LG/R	-

A
B
C
D
E
F
G
H
I
SE
K
L
M
N
O
P

POWER SEAT CONTROL SYSTEM (PASSENGER SIDE)

< WIRING DIAGRAM >

POWER SEAT FOR PASSENGER SIDE

Connector No.	B569
Connector Name	SLIDING MOTOR
Connector Type	YAZAKI 7283-1069

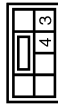

Terminal No.	Color of Wire	Signal Name [Specification]
3	G	
4	G/R	

Connector No.	B570
Connector Name	LIFTING MOTOR (FRONT)
Connector Type	TYCO 988182



Terminal No.	Color of Wire	Signal Name [Specification]
9	L/R	
10	L/B	

Connector No.	B571
Connector Name	LIFTING MOTOR (REAR)
Connector Type	TYCO 988182



Terminal No.	Color of Wire	Signal Name [Specification]
7	L	
8	L/W	

Connector No.	B572
Connector Name	WIRE TO WIRE
Connector Type	NSUDPW-CS

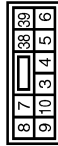

Terminal No.	Color of Wire	Signal Name [Specification]
3	G/W	
4	G/B	
5	R/W	
6	R/G	
7	Y/B	
8	Y/R	
9	LG/R	
10	LG/B	
38	Y/W	
39	Y	

Connector No.	B573
Connector Name	WIRE TO WIRE
Connector Type	NSIDMW-CS



Terminal No.	Color of Wire	Signal Name [Specification]
3	G	
4	G/R	
5	V	
6	R/L	
7	L	
8	L/W	
9	L/R	
10	L/B	
38	Y/W	
39	Y	

Connector No.	E106
Connector Name	WIRE TO WIRE
Connector Type	TH8DFW-CSI (P-TM)



Terminal No.	Color of Wire	Signal Name [Specification]
1	P	
2	W	
3	SB	
4	LG	
5	O	
7	GR	
8	G	
9	Y	
10	BR	
11	SB	
12	V	
13	GR	
14	GR	
15	V	
16	Y	
17	GR	
18	V	
20	BR	
21	P	
22	L	
23	P	
27	SHIELD	
28	L/O	
29	W/L	
31	BR	
32	G	
33	O	
34	Y	
40	BR	
41	BR	
42	L	
43	P	
44	W	
45	L	
46	GR	
47	V	
48	G	
49	O	

50	LG	
60	W	
61	G	
62	Y	
63	BR	
64	B	
65	Y	
66	R	
67	SB	
77	O	
78	SB	
80	G	
81	R	
82	SB	
83	GR	
84	Y	
85	Y	
86	L	
87	V	
88	BR	
89	LG	
90	W	
91	W	
92	P	
93	LG	
94	BR	
95	W	
96	R	
97	R	
98	Y	
99	V	
100	V	

POWER SEAT CONTROL SYSTEM (PASSENGER SIDE)

< WIRING DIAGRAM >

POWER SEAT FOR PASSENGER SIDE

Connector No.	M1
Connector Name	FUSE BLOCK (W/B)
Connector Type	HS08FW-M2



Terminal No.	Color of Wire	Signal Name [Specification]
1A	R	-
2A	W	-
3A	Y	-
4A	W	-
5A	V	-
6A	Y	-
8A	Y	-

Connector No.	M6
Connector Name	WIRE TO WIRE
Connector Type	TH8DMW-CS16-TM4



Terminal No.	Color of Wire	Signal Name [Specification]
1	W	-
2	W	-
3	SB	-
4	LG	-
5	W	-
7	BG	-
8	G	-
9	Y	-
10	W	-
11	R	-
12	V	-
13	LG	-
14	L	-
15	V	-
16	B	-

17	GR	-
18	V	-
20	SB	-
21	BR	-
22	L	-
23	P	-
27	SHIELD	-
28	V	-
29	SB	-
31	BG	-
32	P	-
33	R	-
34	BG	-
40	BR	-
41	BR	-
42	L	-
43	P	-
44	BR	-
45	Y	-
46	BG	-
47	V	-
48	G	-
49	BG	-
50	W	-
60	GR	-
61	B	-
62	LG	-
63	BR	-
64	L	-
65	R	-
66	P	-
67	L	-
77	B	-
78	V	-
80	G	-
81	L	-
82	B	-
83	BG	-
84	SB	-
85	Y	-
86	L	-
87	V	-
88	V	-
89	LG	-
90	BG	-
91	W	-
92	BG	-
93	G	-
94	Y	-
95	W	-
96	W	-
97	SB	-

98	R	-
99	W	-
100	L	-

Connector No.	M17
Connector Name	WIRE TO WIRE
Connector Type	TH8DFW-CS16-TM4

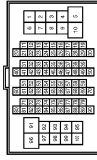

Terminal No.	Color of Wire	Signal Name [Specification]
3	Y	-
17	GR	-
18	P	-
19	BR	-
20	GR	-
21	Y	-
22	LG	-
23	R	-
24	BG	-
25	LG	-
26	W	-
27	R	-
28	V	-
29	P	-
30	B	-
31	G	-
32	Y	-
40	SHIELD	-
41	R	-
42	V	-
44	W	-
45	SB	-
46	L	-
46	L	- [With Climate controlled seat]
46	BG	- [With heated seat]
47	G	- [With Climate controlled seat]
47	GR	- [With Climate controlled seat]
48	V	- [With heated seat]
49	BG	-
50	LG	-
51	SB	-
52	W	-
53	W	-
56	R	-
58	B	-

57	G	-
58	R	-
59	W	-
61	LG	-
62	V	-
63	R	-
65	L	-
67	Y	-
68	SB	-
69	B	-
70	R	-
76	SHIELD	-
77	G	-
78	R	-
79	L	-
80	G	-
81	BG	-
82	BR	-
83	GR	-
84	V	-
85	LG	-
86	V	-
87	R	-
88	Y	-
89	BR	-
90	L	-
91	Y	-
93	W	- [With Climate controlled seat]
93	G	- [With heated seat]
94	V	-
96	W	-
97	Y	-
98	BR	-
99	G	-
100	Y	-

A
B
C
D
E
F
G
H
I
K
L
M
N
O
P

SE

POWER SEAT CONTROL SYSTEM (PASSENGER SIDE)

< WIRING DIAGRAM >

POWER SEAT FOR PASSENGER SIDE

Connector No.	M122
Connector Name	BCM (BODY CONTROL MODULE)
Connector Type	FE/08FM-FHA6-SA



56	57	58	59	60	61	62	63	64
65	66	67	68	69	70			

Terminal No.	Color of Wire	Signal Name (Specification)
56	R	INT ROOM LAMP PWR SPPLY
57	R	BAT (FUSE)
58	L	AIR BAG
59	G	PASS DOOR UNLK OUTPUT
60	G	TURN SIG LH OUTPUT
61	V	TURN SIG RH OUTPUT
62	V	STEP LAMP CONT
63	L	ROOM LAMP TIMER CONT
65	V	ALL DOOR FL LID LOCK OUTPUT
66	LG	DR DOOR FL LID UNLK OUTPUT
67	B	GNB
68	BIG	PW PWR SPPLY (IGN)
69	Y	PW PWR SPPLY (BAT)
70	W	BAT (F/L)

JCJWA1231GB

LUMBAR SUPPORT SYSTEM

< WIRING DIAGRAM >

LUMBAR SUPPORT SYSTEM

Wiring Diagram

INFOID:000000005986943

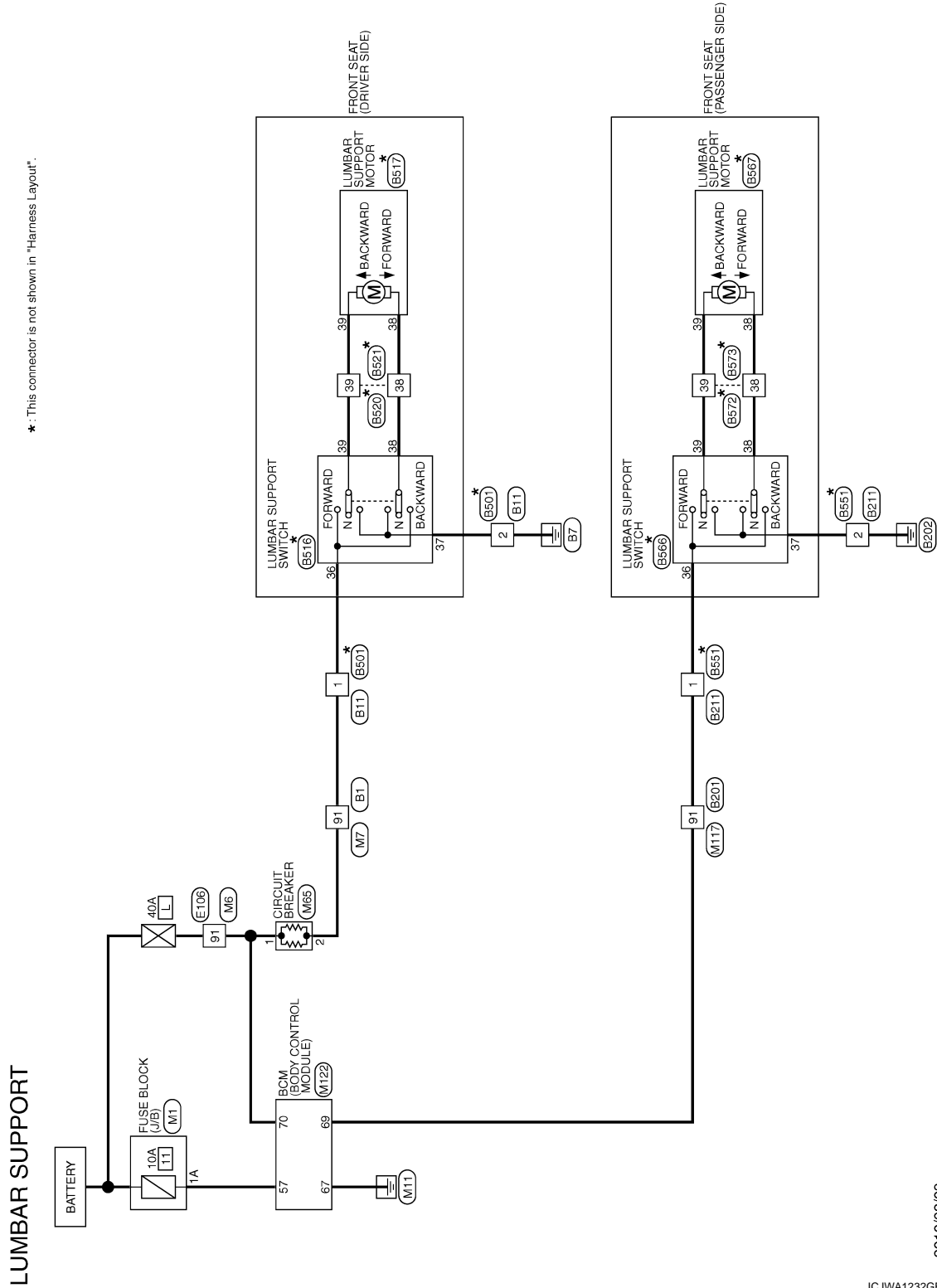

*: This connector is not shown in "Harness Layout".



2010/02/03

JCJWA1232GB

A
B
C
D
E
F
G
H
I
SE
K
L
M
N
O
P

LUMBAR SUPPORT SYSTEM

< WIRING DIAGRAM >

LUMBAR SUPPORT		B11			
Connector No.	B11	Connector No.	B11		
Connector Name	WIRE TO WIRE	Connector Name	WIRE TO WIRE		
Connector Type	THBDFW-CS16-TM4	Connector Type	NS16FW-CS		
					
Terminal No.	Color of Wire	Signal Name [Specification]	Terminal No.	Color of Wire	Signal Name [Specification]
1	R	-	1	SB	-
2	W	-	2	B	-
4	LG	-	23	L	-
5	P	-	24	P	-
6	V	-	25	BR	-
7	GR	-	26	W	-
8	Y	-	27	L	-
9	LG	-	28	P	-
10	V	-	29	O	-
11	GR	- [With Climate controlled seat]	30	V	-
11	L	- [With heated seat]	31	BR	-
12	P	- [With Climate controlled seat]	32	LG	-
12	GR	- [With heated seat]	35	LG	-
13	BR	-	40	O	-
14	R	-	41	B	-
15	O	-			
16	V	-			
17	B	-			
18	R	-			
19	W	-			
20	R	-			
21	B	-			
22	LG	-			
23	V	-			
24	Y	-			
25	G	-			
26	GR	-			
27	SB	-			
28	P	- [With Pre-crash seat belt system]			
28	L/O	- [Without Pre-crash seat belt system]			
29	L	- [With Pre-crash seat belt system]			
29	W/L	- [Without Pre-crash seat belt system]			
30	SHIELD	-			
32	L	-			
33	R	-			
34	L	-			
35	R	-			
36	R	-			
36	G	-			
37	SB	-	37	G	-
40	SHIELD	-	40	P	-
41	GR/V	-	56	BR	-
42	W/L	-	57	LG	-
45	W	-	58	LG	-
47	V	-	59	Y	-
48	V	-	60	W	-
49	BR	-	61	B	-
50	SB	-	62	LG	-
51	V	-	63	BR	- [With ICC and 4WAS system]
52	LG	-	63	V	- [Without ICC and 4WAS system]
53	G	-	65	O	-
56	P	-	66	BR	-
57	BR	-	67	V	-
58	LG	-	68	LG	-
59	Y	-	69	GR	-
60	W	-	70	R	-
61	B	-	72	L	-
62	LG	-	73	P	-
63	BR	-	74	L	-
65	O	-	75	P	-
66	BR	-	76	Y	-
67	V	-	77	R	-
68	LG	-	78	W	-
69	GR	-	79	G	-
70	R	-	81	LG	-
72	L	-	82	BR	-
73	P	-	83	SB	-
74	L	-	84	Y	-
75	P	-	85	W	-
76	Y	-	86	R	-
77	R	-	87	G	-
78	W	-	88	GR	-
79	G	-	91	SB	-
81	LG	-	92	G	-
82	BR	-	96	Y	-
83	SB	-	97	O	-
84	Y	-	98	SB	-
85	W	-	98	LG	-
86	R	-	99	LG	-
87	G	-			
88	GR	-			
91	SB	-			
92	G	-			
96	Y	-			
97	O	-			
98	SB	-			
98	LG	-			
99	LG	-			

JCJWA1233GB

LUMBAR SUPPORT SYSTEM

< WIRING DIAGRAM >

LUMBAR SUPPORT

Terminal No.	Color of Wire	Signal Name [Specification]
3	R	-
17	GR	-
18	P	-
19	BR	-
20	GR	-
21	Y	-
22	GR	-
23	R	-
24	V	-
25	B	-
26	W	-
27	W	-
28	V	-
29	P	-
30	O	-
31	B/R	-
32	Y	-
40	SHIELD	-
41	W/R	-
42	V	-
44	P	-
45	SB	-
46	R	- [With Climate controlled seat]
46	Y	- [With heated seat]
47	G	- [With Climate controlled seat]
47	GR	- [With heated seat]
48	V	-
49	O	-
50	R	-
51	GR	-
52	LG	-
53	P	-
56	P	-
57	W	-
58	O	-
58	V	-
61	SB	-
62	L	-

Terminal No.	Color of Wire	Signal Name [Specification]
63	W	-
66	L	-
67	Y	-
68	SB	-
69	B	-
70	R	-
76	SHIELD	-
77	G	-
78	R	-
79	P	-
80	G	-
81	P	-
82	BR	-
83	GR	-
84	V	-
85	LG	-
86	W	-
87	O	-
88	Y	-
89	BR	-
90	L	-
91	BR	-
93	Y	- [With Climate controlled seat]
93	O	- [With heated seat]
94	GR	-
96	W	-
97	P	-
98	LG	-
99	LG	-
100	Y	-

Terminal No.	Color of Wire	Signal Name [Specification]
1	BR	-
2	B	-
35	G	-
40	L	-
41	B	-
46	Y	-

Terminal No.	Color of Wire	Signal Name [Specification]
47	BR	-
48	SHIELD	-
49	L	-
50	B/W	-
52	SB	-
53	O	-
54	R	- [With Climate controlled seat]
54	B	- [With heated seat]
55	Y	-
56	G	-
57	V	-
58	B	- [With Climate controlled seat]
58	GR	- [With heated seat]

Terminal No.	Color of Wire	Signal Name [Specification]
24	23	34
40	41	35
28	27	1
26	25	28
23	22	31
21	20	30
19	18	29

Terminal No.	Color of Wire	Signal Name [Specification]
1	R	-
2	B	-
23	P	-
24	P/L	-
25	G/O	-
26	L/O	-
27	V	-
28	V/W	-
29	L	-
30	BR	-
31	BR/W	-
32	W/L	-
35	W/Y	-
40	W/G	-
41	GR	-

Connector No.	Color of Wire	Signal Name [Specification]
B516	-	-

Connector Name	Color of Wire	Signal Name [Specification]
LUMBAR SUPPORT SWITCH	-	-

Connector Type	Color of Wire	Signal Name [Specification]
NSDMFY-CS	-	-



Terminal No.	Color of Wire	Signal Name [Specification]
36	R	-
37	LG	-
38	Y/W	-
39	Y	-

Connector No.	Color of Wire	Signal Name [Specification]
B517	-	-

Connector Name	Color of Wire	Signal Name [Specification]
LUMBAR SUPPORT MOTOR	-	-

Connector Type	Color of Wire	Signal Name [Specification]
YAZAKI 7283-1020	-	-



Terminal No.	Color of Wire	Signal Name [Specification]
36	R	-
37	LG	-
38	Y/W	-
39	Y	-

JCJWA1234GB

A
B
C
D
E
F
G
H
I
SE
K
L
M
N
O
P

LUMBAR SUPPORT SYSTEM

< WIRING DIAGRAM >

LUMBAR SUPPORT

Connector No.	B520
Connector Name	WIRE TO WIRE
Connector Type	NS10FW-CS



8	7	38	39
9	10	4	3
5	6	1	2

Terminal No.	Color of Wire	Signal Name [Specification]
3	G	-
4	G/R	-
5	V	-
6	R/L	-
7	L	-
8	L/W	-
9	L/R	-
10	L/B	-
38	Y/W	-
39	Y	-

Connector No.	B521
Connector Name	WIRE TO WIRE
Connector Type	NS10MW-CS



39	38	7	8
6	5	4	3
10	9	1	2

Terminal No.	Color of Wire	Signal Name [Specification]
3	G	-
4	G/R	-
5	V	-
6	R/L	-
7	L	-
8	L/W	-
9	L/R	-
10	L/B	-
38	Y/W	-
39	Y	-

Connector No.	B551
Connector Name	WIRE TO WIRE
Connector Type	TK10MW-NS8



34	50	49	57	40
56	1	58	55	1
54	2	53	48	47
52	3	51	46	45

Terminal No.	Color of Wire	Signal Name [Specification]
1	R	-
2	B	-
3	W/Y	-
4	W/G	-
41	GR	-
46	R	-
47	G	-
48	R/Y	-
49	P	-
50	L	-
52	L/B	-
53	Y/W	- [With Climate controlled seat]
54	R/W	- [With heater seat]
55	Y	- [With Climate controlled seat]
56	B/W	- [With Climate controlled seat]
57	G/R	- [With heater seat]
58	LG/R	- [With heater seat]
59	V	-
60	B/P	-
61	B/W	- [With Climate controlled seat]
62	LG/B	- [With heater seat]

Connector No.	B586
Connector Name	LUMBAR SUPPORT SWITCH
Connector Type	NS04FW-CS



37	36	38	39
----	----	----	----

Terminal No.	Color of Wire	Signal Name [Specification]
36	R	-

37	LG	-
38	Y/W	-
39	Y	-



Connector No.	B567
Connector Name	LUMBAR SUPPORT MOTOR
Connector Type	YAZAKI 7283-1020



39	38	33
----	----	----

Terminal No.	Color of Wire	Signal Name [Specification]
38	Y/W	-
39	Y	-

Connector No.	B572
Connector Name	WIRE TO WIRE
Connector Type	NS10FW-CS



8	7	38	39
9	10	4	3
5	6	1	2

Terminal No.	Color of Wire	Signal Name [Specification]
3	G/W	-
4	G/B	-
5	R/W	-
6	R/G	-
7	Y/B	-
8	Y/R	-
9	LG/R	-
10	LG/B	-
38	Y/W	-
39	Y	-

Connector No.	B573
Connector Name	WIRE TO WIRE
Connector Type	NS10MH-CS



39	38	7	8
6	5	4	3
10	9	1	2

Terminal No.	Color of Wire	Signal Name [Specification]
3	G	-
4	G/R	-
5	V	-
6	R/L	-
7	L	-
8	L/W	-
9	L/R	-
10	L/B	-
38	Y/W	-
39	Y	-

LUMBAR SUPPORT SYSTEM

< WIRING DIAGRAM >

LUMBAR SUPPORT

Connector No.	E106
Connector Name	WIRE TO WIRE
Connector Type	TH80FW-CS16-TM4



Terminal No.	Color of Wire	Signal Name [Specification]
1	P	
2	W	
3	SB	
4	LG	
5	O	
7	GR	
8	G	
9	Y	
10	BR	
11	SB	
12	V	
13	GR	
14	GR	
15	V	
16	Y	
17	GR	
18	V	
20	BR	
21	P	
22	L	
23	P	
27	SHIELD	
28	L/O	
31	BR	
32	G	
33	O	
34	Y	
40	BR	
41	BR	
42	L	
43	P	
44	W	
45	L	
46	GR	
47	V	
48	G	
49	O	

50	LG	
60	W	
61	G	
62	Y	
63	BR	
64	B	
65	Y	
66	R	
67	SB	
77	O	
78	SB	
80	G	
81	R	
82	SB	
83	GR	
84	Y	
85	Y	
86	L	
87	V	
88	BR	
89	LG	
90	W	
91	W	
92	P	
93	LG	
94	BR	
95	W	
96	R	
97	R	
98	Y	
99	V	
100	V	

Connector No.	M1
Connector Name	FUSE BLOCK (J/B)
Connector Type	NS06FW-M2



Terminal No.	Color of Wire	Signal Name [Specification]
1A	R	
2A	W	
3A	Y	
4A	W	

5A	V	
6A	Y	
8A	Y	

Connector No.	M6
Connector Name	WIRE TO WIRE
Connector Type	TH80MW-CS16-TM4

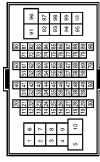

Terminal No.	Color of Wire	Signal Name [Specification]
1	W	
2	W	
3	SB	
4	LG	
5	W	
7	EG	
8	G	
9	Y	
10	W	
11	R	
12	V	
13	LG	
14	L	
15	V	
16	B	
17	GR	
18	V	
20	SB	
21	BR	
22	L	
23	P	
27	SHIELD	
29	SB	
31	EG	
32	P	
33	R	
34	EG	
40	BR	
41	BR	
42	L	
43	P	
44	BR	

45	Y	
46	EG	
47	V	
48	G	
49	EG	
50	W	
60	GR	
61	B	
62	LG	
63	BR	
64	L	
65	R	
66	P	
67	L	
77	B	
78	V	
80	G	
81	L	
82	B	
83	EG	
84	SB	
85	Y	
86	L	
87	V	
88	V	
89	LG	
90	EG	
91	W	
92	EG	
93	G	
94	Y	
95	W	
96	R	
97	SB	
98	R	
99	W	
100	L	

A
B
C
D
E
F
G
H
I
K
L
M
N
O
P

SE

LUMBAR SUPPORT SYSTEM

< WIRING DIAGRAM >

LUMBAR SUPPORT

Connector No.	M7
Connector Name	WIRE TO WIRE
Connector Type	TH80MW-CS16-TM4



Terminal No.	Color of Wire	Signal Name [Specification]
1	G	-
2	Y	-
4	BR	-
5	P	-
6	W	-
7	G	-
8	Y	-
9	G	-
10	V	-
11	V	- [With Climate controlled seat]
12	P	- [With heated seat]
13	GR	- [With Climate controlled seat]
14	BR	- [With heated seat]
15	GR	-
16	BG	-
17	BG	- [With ICC]
18	B	- [Without ICC]
19	W	-
20	R	-
21	B	-
22	LG	-
23	W	-
24	V	-
25	G	-
26	BR	-
27	SB	-
28	P	-
29	L	-
30	SHIELD	-
32	L	-
33	P	-
34	L	-
35	P	-
36	BG	-
37	SB	-

40	SHIELD	-
41	SR	-
42	V	-
45	W	-
47	L	-
48	LG	-
49	BR	-
50	V	-
51	V	-
52	P	-
53	BG	-
56	SB	-
57	P	-
58	LG	-
59	Y	-
60	GR	-
61	B	-
62	LG	-
63	BR	-
65	W	-
66	R	-
67	V	-
68	LG	-
69	SB	-
70	V	-
72	L	-
73	P	-
74	L	-
75	P	-
76	P	-
77	Y	-
78	SB	-
79	W	-
81	LG	-
82	BR	-
83	BG	-
84	B	-
85	W	-
86	G	-
87	R	-
88	G	-
91	W	-
92	G	-
96	W	-
97	BG	-
98	Y	-
99	LG	-

Connector No.	M85
Connector Name	CIRCUIT BREAKER
Connector Type	IM82FW-LC



Terminal No.	Color of Wire	Signal Name [Specification]
1	W	-
2	W	-

Connector No.	M117
Connector Name	WIRE TO WIRE
Connector Type	TH80FW-CS16-TM4



Terminal No.	Color of Wire	Signal Name [Specification]
3	Y	-
17	GR	-
18	P	-
19	BR	-
20	GR	-
21	Y	-
22	LG	-
23	R	-
24	BG	-
25	LG	-
26	W	-
27	R	-
28	V	-
29	P	-
30	B	-
31	G	-
32	Y	-
40	SHIELD	-
41	R	-
42	V	-

44	W	-
45	SR	-
46	L	- [With Climate controlled seat]
48	BG	- [With heated seat]
47	G	- [With Climate controlled seat]
47	GR	- [With heated seat]
48	V	-
49	BG	-
50	LG	-
51	SB	-
52	Y	-
53	W	-
56	B	-
57	G	-
58	R	-
59	W	-
61	LG	-
62	V	-
63	R	-
65	L	-
67	Y	-
68	SB	-
69	B	-
70	R	-
76	SHIELD	-
77	G	-
78	R	-
79	L	-
80	G	-
81	BG	-
82	BR	-
83	GR	-
84	V	-
85	LG	-
86	V	-
87	R	-
88	Y	-
89	BR	-
90	L	-
91	Y	-
93	W	- [With Climate controlled seat]
93	G	- [With heated seat]
94	V	-
96	W	-
97	Y	-
98	BR	-
99	G	-
100	Y	-

LUMBAR SUPPORT SYSTEM

< WIRING DIAGRAM >

A
B
C
D
E
F
G
H
I
SE
K
L
M
N
O
P

LUMBAR SUPPORT

Connector No.	M122
Connector Name	BCM (BODY CONTROL MODULE)
Connector Type	FEA08FW-FTAF-SA



56	57	58	59	60	61	62	63	64
65	66	67	68	69	70			

Terminal No.	Color of Wire	Signal Name (Specification)
56	R	INT ROOM LAMP PWR SPLY
57	R	BAT (FUSE)
58	L	AIR BAG
59	G	PASS DOOR UNLK OUTPUT
60	G	TURN SIG LH OUTPUT
61	V	TURN SIG RH OUTPUT
62	V	STEP LAMP CONT
63	L	ROOM LAMP TIMER CONT
65	V	ALL DOOR FL ID LOCK OUTPUT
66	LG	DR DOOR FL ID UNLK OUTPUT
67	B	GNL
68	BG	PW PWR SPLY (IGN)
69	Y	PW PWR SPLY (BAT)
70	W	BAT (P/L)

JCJWA1238GB

CLIMATE CONTROLLED SEAT SYSTEM

< WIRING DIAGRAM >

CLIMATE CONTROLLED SEAT SYSTEM

Wiring Diagram

INFOID:000000005986773

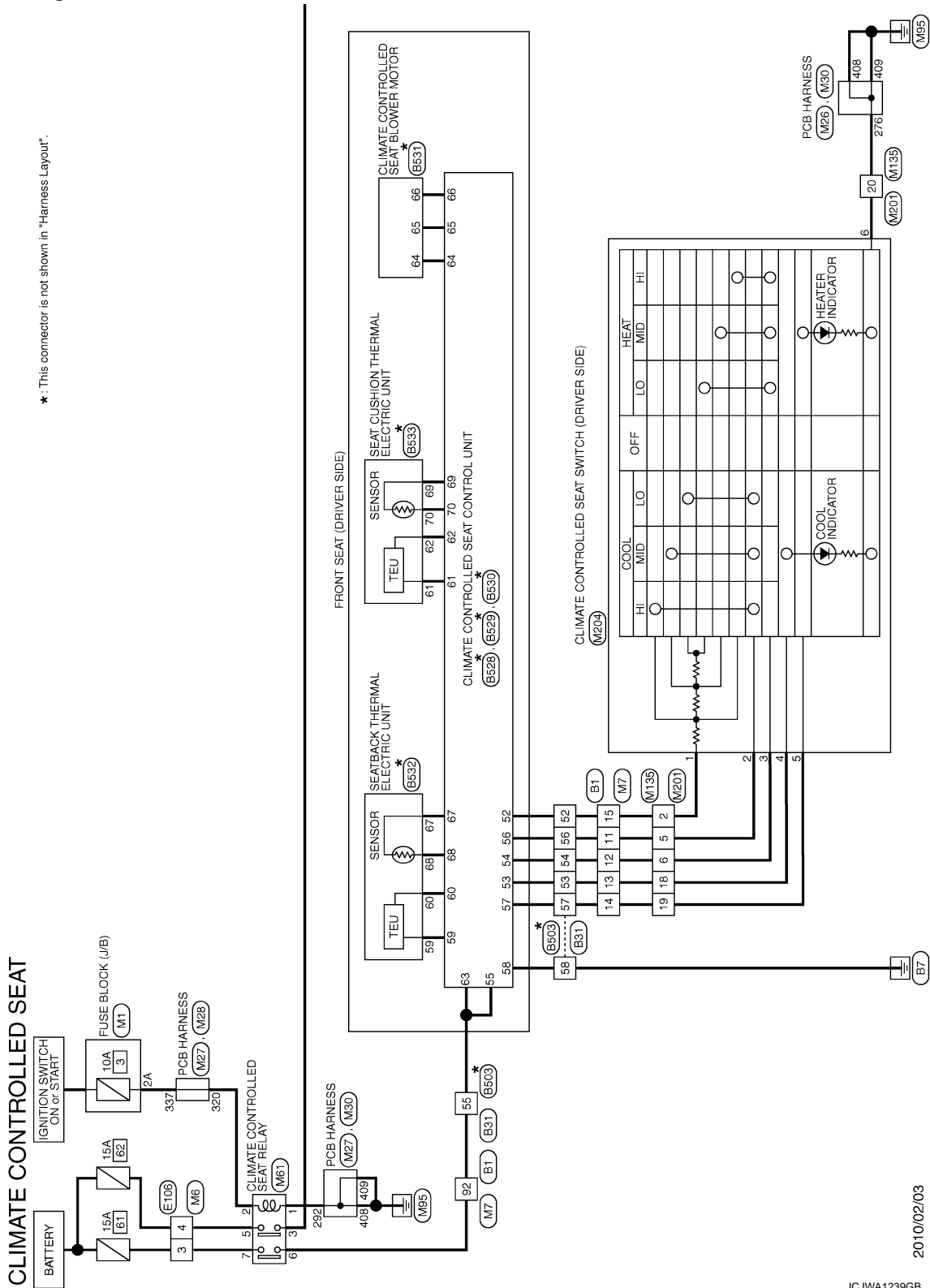

2010/02/03

JCJWA1239GB

CLIMATE CONTROLLED SEAT SYSTEM

< WIRING DIAGRAM >

*: This connector is not shown in "Harness Layout".

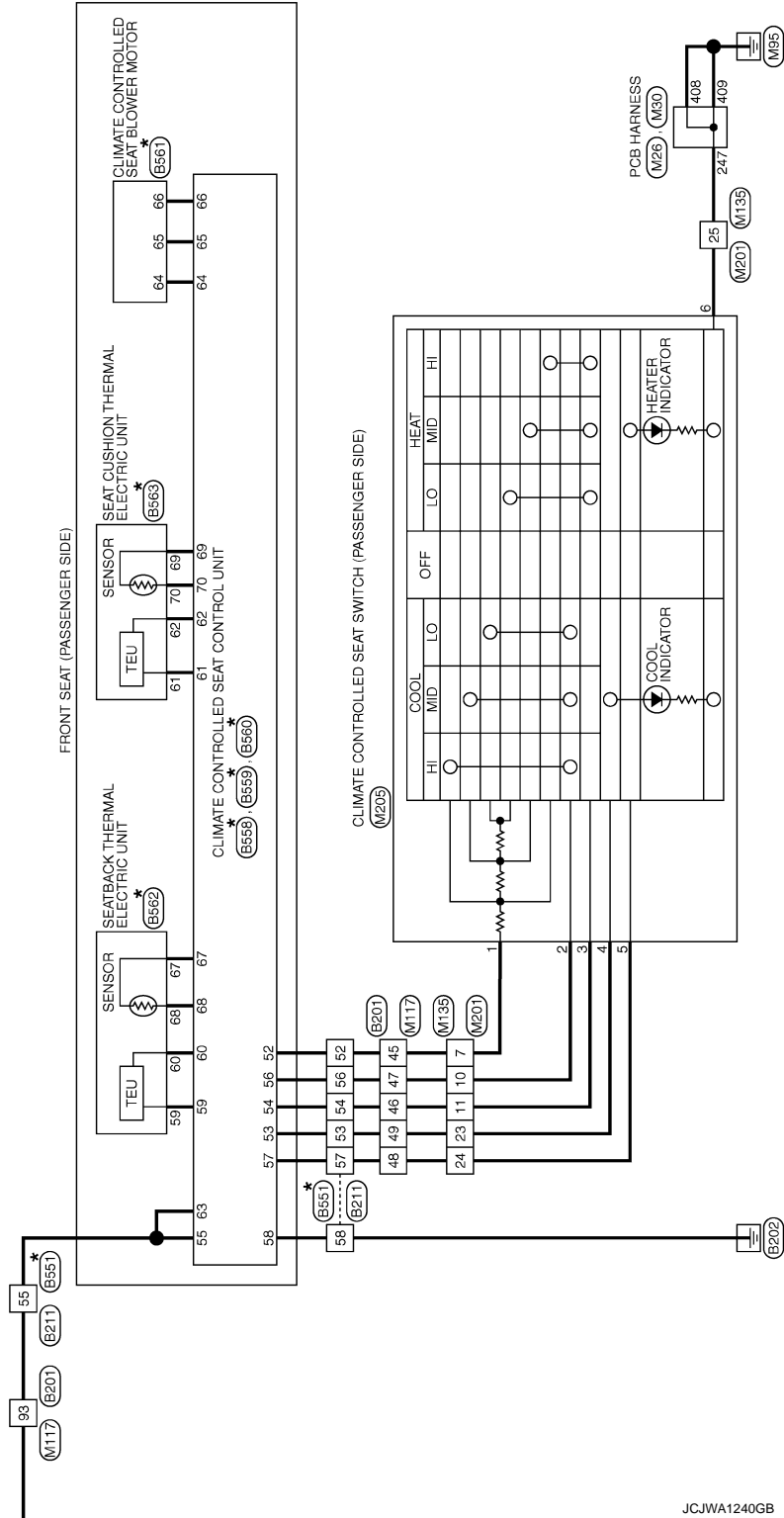

JCJWA1240GB

A
B
C
D
E
F
G
H
I
SE
K
L
M
N
O
P

CLIMATE CONTROLLED SEAT SYSTEM

< WIRING DIAGRAM >

CLIMATE CONTROLLED SEAT

Connector No.	B1
Connector Name	WIRE TO WIRE
Connector Type	THBDFW-CS16-TM4

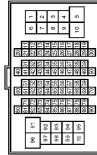

Terminal No.	Color of Wire	Signal Name [Specification]
1	R	-
2	W	-
4	LG	-
5	P	-
6	V	-
7	GR	-
8	Y	-
9	LG	-
10	V	-
11	GR	- [With Climate controlled seat]
11	L	- [With heated seat]
12	P	- [With Climate controlled seat]
12	GR	- [With heated seat]
13	GR	-
14	R	-
15	O	-
16	V	-
17	B	-
18	R	-
19	W	-
20	R	-
21	B	-
22	LG	-
23	V	-
24	Y	-
25	G	-
26	GR	-
27	SB	-
28	P	- [With Pre-crash seat belt system]
28	L/O	- [Without Pre-crash seat belt system]
29	L	- [With Pre-crash seat belt system]
29	W/L	- [Without Pre-crash seat belt system]
30	SHIELD	-
32	L	-
33	R	-
34	L	-
35	R	-
36	G	-

37	SB	-
40	SHIELD	-
41	GR/V	-
42	W/L	-
45	W	-
47	V	-
48	Y	-
49	BR	-
50	SB	-
51	V	-
52	LG	-
53	G	-
56	P	-
57	BR	-
58	LG	-
59	Y	-
60	W	-
61	B	-
62	LG	-
63	BR	- [With ICC and 4WAS system]
63	V	- [Without ICC and 4WAS system]
65	O	-
66	BR	-
67	V	-
68	LG	-
69	GR	-
70	R	-
72	L	-
73	P	-
74	L	-
75	P	-
76	Y	-
77	R	-
78	W	-
79	G	-
81	LG	-
82	BR	-
83	SB	-
84	Y	-
85	W	-
86	R	-
87	G	-
88	GR	-
91	SB	-
92	G	-
96	Y	-
97	O	-
98	SB	-
99	LG	-

Connector No.	B31
Connector Name	WIRE TO WIRE
Connector Type	NS12FW-CS



Terminal No.	Color of Wire	Signal Name [Specification]
46	L	-
47	B/W	-
48	SHIELD	-
49	B/R	-
50	BR	-
52	O	- [With Climate controlled seat]
52	G	- [With heated seat]
53	BR	- [With Climate controlled seat]
53	GR	- [With heated seat]
54	P	- [With Climate controlled seat]
54	L	- [With heated seat]
55	G	-
56	GR	-
57	R	-
58	B	-

JCJWA1241GB

CLIMATE CONTROLLED SEAT SYSTEM

< WIRING DIAGRAM >

CLIMATE CONTROLLED SEAT

Connector No.	B201
Connector Name	WIRE TO WIRE
Connector Type	TH8DMW-CS16-TM4



Terminal No.	Color of Wire	Signal Name [Specification]
3	R	-
17	GR	-
18	P	-
19	BR	-
20	GR	-
21	Y	-
22	GR	-
23	R	-
24	V	-
25	B	-
26	W	-
27	W	-
28	V	-
29	P	-
30	O	-
31	B/R	-
32	Y	-
40	SHIELD	-
41	W/R	-
42	V	-
44	P	-
45	SB	-
46	R	- [With Climate controlled seat]
47	G	- [With heated seat]
47	GR	- [With Climate controlled seat]
48	V	- [With heated seat]
49	O	-
50	R	-
51	GR	-
52	LG	-
53	P	-
56	P	-
57	W	-
58	O	-
58	V	-
61	SB	-
62	L	-

63	W	-
66	L	-
67	Y	-
68	SB	-
69	B	-
70	R	-
76	SHIELD	-
77	G	-
78	R	-
79	P	-
80	G	-
81	P	-
82	BR	-
83	GR	-
84	V	-
85	LG	-
86	W	-
87	O	-
88	Y	-
89	BR	-
90	L	-
91	BR	-
93	Y	- [With Climate controlled seat]
93	O	- [With heated seat]
94	GR	-
96	W	-
97	P	-
98	LG	-
99	LG	-
100	Y	-

Connector No.	B211
Connector Name	WIRE TO WIRE
Connector Type	TK10FW-NS8



Terminal No.	Color of Wire	Signal Name [Specification]
1	BR	-
2	B	-
35	G	-
40	L	-
41	B	-
46	Y	-

47	BR	-
48	SHIELD	-
49	L	-
50	B/W	-
52	SB	-
53	O	-
54	R	- [With Climate controlled seat]
54	B	- [With heated seat]
55	Y	-
56	G	-
57	V	-
58	B	- [With Climate controlled seat]
58	GR	- [With heated seat]

Connector No.	B503
Connector Name	WIRE TO WIRE
Connector Type	NS1ZMW-CS



Terminal No.	Color of Wire	Signal Name [Specification]
46	R	-
47	G	-
48	R/Y	-
49	P	-
50	L	-
52	L/B	- [With Climate controlled seat]
52	R	- [With heated seat]
53	Y/W	- [With Climate controlled seat]
53	LG/R	- [With heated seat]
54	Y	- [With Climate controlled seat]
54	LG/B	- [With heated seat]
55	G/R	-
56	V	-
57	B/P	-
58	B	-

Connector No.	B528
Connector Name	CLIMATE CONTROLLED SEAT CONTROL UNIT
Connector Type	DELPHI 1532Z141



Terminal No.	Color of Wire	Signal Name [Specification]
55	G/R	Vsatt
58	B	Ground
59	LG/R	Back TED +Heat. (-Cool)
60	LG/B	Back TED -Heat. (+Cool)
61	Y/R	Cush TED +Heat. (-Cool)
62	B/R	Cush TED -Heat. (+Cool)

Connector No.	B529
Connector Name	CLIMATE CONTROLLED SEAT CONTROL UNIT
Connector Type	DELPHI 1540S141

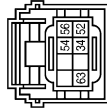

Terminal No.	Color of Wire	Signal Name [Specification]
52	L/B	Heat/Cool SW Resistor Pwr
54	Y	Heat Switch Input
56	V	Cool Switch Input
63	R	Ignition Run

JCJWA1242GB

A
B
C
D
E
F
G
H
I
SE
K
L
M
N
O
P

CLIMATE CONTROLLED SEAT SYSTEM

< WIRING DIAGRAM >

CLIMATE CONTROLLED SEAT

Connector No.	B530
Connector Name	CLIMATE CONTROLLED SEAT CONTROL UNIT
Connector Type	DELPHI 15394150



Terminal No.	Color of Wire	Signal Name [Specification]
53	Y/W	Cool Indicator
57	B/P	Heat Indicator
64	W/R	VM1 (Blower Power)
65	W/B	Blower
66	Y/G	VSPT (Speed Control)
67	L/R	Back Sensor
68	L	Back Sensor Return
69	G/B	Cushion Sensor
70	G/W	Cushion Sensor Return

Connector No.	B531
Connector Name	CLIMATE CONTROLLED SEAT BLOWER MOTOR
Connector Type	YAZAKI 7285-3830



Terminal No.	Color of Wire	Signal Name [Specification]
64	W/R	
65	W/B	
66	Y/G	

Connector No.	B532
Connector Name	SEATBACK THERMAL ELECTRIC UNIT
Connector Type	SUMITOMO 6098-2163



Terminal No.	Color of Wire	Signal Name [Specification]
59	LG/R	
60	LG/B	
67	L/R	
68	L	

Connector No.	B533
Connector Name	SEAT CUSHION THERMAL ELECTRIC UNIT
Connector Type	SUMITOMO 6098-2163



Terminal No.	Color of Wire	Signal Name [Specification]
61	Y/R	
62	B/R	
69	G/B	
70	G/W	

Connector No.	B551
Connector Name	WIRE TO WIRE
Connector Type	TK10MW-NS3



Terminal No.	Color of Wire	Signal Name [Specification]
1	B	
2	R	
35	W/Y	
40	W/G	
41	GR	
46	R	
47	G	
48	R/Y	
49	P	
50	L	
52	L/B	
53	Y/W	[With Climate controlled seat]
54	R/W	[With heated seat]
54	Y	[With Climate controlled seat]
54	B/W	[With heated seat]
55	G/R	[With Climate controlled seat]
55	LG/R	[With heated seat]
56	V	
57	B/P	
58	B/W	[With Climate controlled seat]
58	LG/B	[With heated seat]

Connector No.	B553
Connector Name	CLIMATE CONTROLLED SEAT CONTROL UNIT
Connector Type	DELPHI 1532141



Terminal No.	Color of Wire	Signal Name [Specification]
55	R/L	Voast
58	B/W	Ground
59	LG/R	Back TED +Heat (+Cool)
60	LG/B	Back TED -Heat (-Cool)
61	Y/R	Cush TED +Heat (+Cool)
62	B/R	Cush TED -Heat (-Cool)

Connector No.	B559
Connector Name	CLIMATE CONTROLLED SEAT CONTROL UNIT
Connector Type	DELPHI 15408141

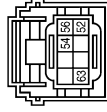

Terminal No.	Color of Wire	Signal Name [Specification]
52	L/B	Heat/Cool SW Resistor Pwr
54	Y	Heat Switch Input
56	V	Cool Switch Input
63	R	Ignition Run

Connector No.	B560
Connector Name	CLIMATE CONTROLLED SEAT CONTROL UNIT
Connector Type	DELPHI 15394150



Terminal No.	Color of Wire	Signal Name [Specification]
53	Y/W	Cool Indicator
57	B/P	Heat Indicator
64	W/R	VM1 (Blower Power)
65	W/B	Blower
66	Y/G	VSPT (Speed Control)
67	L/R	Back Sensor
68	L	Back Sensor Return
69	G/B	Cushion Sensor
70	G/W	Cushion Sensor Return

CLIMATE CONTROLLED SEAT SYSTEM

< WIRING DIAGRAM >

CLIMATE CONTROLLED SEAT

Connector No.	B561
Connector Name	CLIMATE CONTROLLED SEAT BLOWER MOTOR
Connector Type	YAZAKI 7282-5830



Terminal No.	Color of Wire	Signal Name [Specification]
64	W/R	-
65	W/B	-
66	Y/G	-

Connector No.	B562
Connector Name	SEATBACK THERMAL ELECTRIC UNIT
Connector Type	SUMITOMO 6098-2163



Terminal No.	Color of Wire	Signal Name [Specification]
58	LG/R	-
60	LG/B	-
67	L/R	-
68	L	-

Connector No.	B563
Connector Name	SEAT CUSHION THERMAL ELECTRIC UNIT
Connector Type	SUMITOMO 6098-2163



Terminal No.	Color of Wire	Signal Name [Specification]
61	Y/R	-
62	B/R	-
68	G/B	-
70	G/W	-

Connector No.	E106
Connector Name	WIRE TO WIRE
Connector Type	TH80FW-CS16-TM4

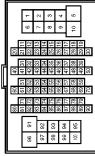

Terminal No.	Color of Wire	Signal Name [Specification]
1	P	-
2	W	-
3	SB	-
4	LG	-
5	GR	-
6	G	-
7	GR	-
8	G	-
9	Y	-
10	BR	-
11	SB	-
12	V	-
13	GR	-
14	GR	-
15	V	-
16	Y	-
17	GR	-
18	V	-
20	BR	-
21	P	-
22	L	-
23	P	-
27	SHIELD	-
28	L/O	-
29	W/L	-
31	BR	-
32	G	-
33	O	-
34	Y	-
40	BR	-
41	BR	-

Terminal No.	Color of Wire	Signal Name [Specification]
42	L	-
43	P	-
44	W	-
45	L	-
46	GR	-
47	V	-
48	G	-
49	O	-
50	LG	-
60	W	-
61	G	-
62	Y	-
63	BR	-
64	B	-
65	Y	-
66	R	-
67	SB	-
77	O	-
78	SB	-
80	G	-
81	R	-
82	SB	-
83	GR	-
84	Y	-
85	Y	-
86	L	-
87	V	-
88	BR	-
89	LG	-
90	W	-
91	W	-
92	P	-
93	LG	-
94	BR	-
95	W	-
96	R	-
97	R	-
98	Y	-
99	V	-
100	V	-

Connector No.	M1
Connector Name	FUSE BLOCK (J/B)
Connector Type	NS06FW-M2



Terminal No.	Color of Wire	Signal Name [Specification]
1A	R	-
2A	W	-
3A	Y	-
4A	W	-
5A	V	-
6A	Y	-
8A	Y	-

A
B
C
D
E
F
G
H
I
SE
K
L
M
N
O
P

CLIMATE CONTROLLED SEAT SYSTEM

< WIRING DIAGRAM >

CLIMATE CONTROLLED SEAT

Connector No.	M6
Connector Name	WIRE TO WIRE
Connector Type	TH80MW-CS16-TM4

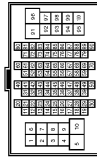

Terminal No.	Color of Wire	Signal Name [Specification]
1	W	
2	W	
3	SB	
4	LG	
5	W	
7	BG	
8	G	
9	Y	
10	W	
11	R	
12	V	
13	LG	
14	L	
15	V	
16	B	
17	GR	
18	V	
20	SB	
21	BR	
22	L	
23	P	
27	SHIELD	
28	V	
29	SB	
31	BG	
32	P	
33	R	
34	BG	
40	BR	
41	BR	
42	L	
43	P	
44	BR	
45	Y	
46	BG	
47	V	
48	G	
49	BG	

50	W	
60	GR	
61	B	
62	LG	
63	BR	
64	L	
65	R	
66	P	
67	L	
77	B	
78	V	
80	G	
81	L	
82	B	
83	BG	
84	SB	
85	Y	
86	L	
87	V	
88	V	
89	LG	
90	BG	
91	W	
92	BG	
93	G	
94	Y	
95	W	
96	R	
97	SB	
98	R	
99	W	
100	L	

Connector No.	M7
Connector Name	WIRE TO WIRE
Connector Type	TH80MW-CS16-TM4



Terminal No.	Color of Wire	Signal Name [Specification]
1	G	
2	Y	
4	BR	
5	P	

6	W	
7	G	
8	Y	
9	G	
10	V	
11	V	- [With Climate controlled seat]
12	P	- [With Heater seat]
13	GR	- [With Climate controlled seat]
14	BR	- [With Heater seat]
15	BG	
16	V	
17	BG	- [With ICC]
17	B	- [Without ICC]
18	L	
19	W	
20	R	
21	B	
22	LG	
23	W	
24	V	
25	G	
26	BR	
27	SB	
28	P	
29	L	
30	SHIELD	
32	L	
33	P	
34	L	
35	P	
36	BG	
37	SB	
40	SHIELD	
41	SB	
42	V	
45	W	
47	L	
48	LG	
49	BR	
50	V	
51	V	
52	P	
53	BG	
56	SB	
57	P	
58	LG	
59	Y	
60	GR	
61	B	
62	LG	

63	BR	
65	W	
66	R	
67	V	
68	LG	
69	SB	
70	V	
72	L	
73	P	
74	L	
75	P	
76	G	
77	Y	
78	SB	
79	W	
81	LG	
82	BR	
83	BG	
84	B	
85	W	
86	G	
87	R	
88	G	
91	W	
92	G	
96	W	
97	BG	
98	Y	
99	LG	

CLIMATE CONTROLLED SEAT SYSTEM

< WIRING DIAGRAM >

CLIMATE CONTROLLED SEAT

Connector No.	M26
Connector Name	POB HARNESS
Connector Type	TH40FW-NH

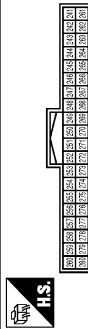

Terminal No.	Color of Wire	Signal Name [Specification]
241	L	-
243	R	-
244	L	-
245	B	-
246	B	-
247	LG	- [With Climate controlled seat]
249	B	- [With heated seat]
250	SHIELD	-
253	P	- [With Climate controlled seat]
253	B	- [With heated seat]
254	W	- [With Climate controlled seat]
254	B	- [With heated seat]
255	B	-
256	SHIELD	-
257	SHIELD	-
258	R	-
259	L	-
260	BG	-
261	P	-
269	GR	-
270	Y	-
271	BR	-
272	G	-
273	R	-
274	R	-
275	Y	-
276	B	-
277	G	-
278	R	-
279	SB	- [With Climate controlled seat]
279	R	- [With heated seat]
280	Y	-

Connector No.	M27
Connector Name	POB HARNESS
Connector Type	TH40FB-NH

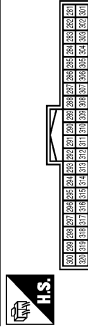

Terminal No.	Color of Wire	Signal Name [Specification]
282	BG	-
283	BG	-
284	LG	-
286	W	-
287	Y	-
288	W	-
290	B	-
292	B	-
293	B	-
294	B	-
295	B	-
299	V	-
301	R	-
302	R	-
303	R	-
319	V	-
320	W	-

Connector No.	M28
Connector Name	POB HARNESS
Connector Type	TH40FW-NH

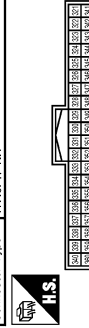

Terminal No.	Color of Wire	Signal Name [Specification]
321	V	-
322	V	-
324	B	-
325	L	-
326	L	-

327	P	-
328	P	-
330	B	-
331	V	-
332	Y	-
333	B	-
337	W	-
338	W	-
343	L	-
344	B	-
345	Y	-
346	L	-
347	P	-
348	GR	-
349	V	-
350	LG	-
351	P	-
352	R	-
353	P	-
358	W	-
359	W	-
360	G	-

Connector No.	M30
Connector Name	POB HARNESS
Connector Type	TH40FW-NH



Terminal No.	Color of Wire	Signal Name [Specification]
402	R	-
403	R	-
407	V	-
408	B	-
409	B	-
410	B	-
411	B	-
413	Y	-
414	BR	-
416	LG	-
417	B	-
419	SB	-
420	SHIELD	-
422	V	-

427	P	-
428	V	-
429	P	-
430	LG	-
431	B	-
432	V	-
435	V	-
436	BG	-
437	B	-
438	P	-
439	L	-

Connector No.	M61
Connector Name	CLIMATE CONTROLLED SEAT RELAY
Connector Type	M06FBR-F-LC

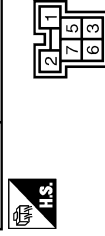

Terminal No.	Color of Wire	Signal Name [Specification]
1	B	-
2	W	-
3	W	-
5	LG	-
6	G	-
7	SB	-

A
B
C
D
E
F
G
H
I
SE
K
L
M
N
O
P

CLIMATE CONTROLLED SEAT SYSTEM

< WIRING DIAGRAM >

CLIMATE CONTROLLED SEAT

Connector No.	M117
Connector Name	WIRE TO WIRE
Connector Type	TH3DFW-CS16-TM4



Terminal No.	Color of Wire	Signal Name [Specification]
3	Y	-
17	GR	-
18	P	-
19	BR	-
20	GR	-
21	Y	-
22	LG	-
23	R	-
24	BG	-
25	LG	-
26	W	-
27	R	-
28	V	-
29	P	-
30	B	-
31	G	-
32	Y	-
40	SHIELD	-
41	R	-
42	V	-
44	W	-
45	SB	-
46	L	- [With Climate controlled seat] - [With heated seat]
47	G	- [With Climate controlled seat]
48	V	- [With heated seat]
49	BG	-
50	LG	-
51	SB	-
52	Y	-
53	W	-
56	B	-
57	G	-
58	R	-
59	W	-
61	LG	-
62	V	-

63	R	-
66	L	-
67	Y	-
68	SB	-
69	BR	-
70	P	-
76	SHIELD	-
77	G	-
78	R	-
79	L	-
80	G	-
81	BG	-
82	BR	-
83	GR	-
84	V	-
85	LG	-
86	V	-
87	R	-
88	Y	-
89	BR	-
90	L	-
91	Y	-
93	W	- [With Climate controlled seat] - [With heated seat]
94	V	-
96	W	-
97	Y	-
98	BR	-
99	G	-
100	Y	-



Connector No.	M135
Connector Name	WIRE TO WIRE
Connector Type	TH32FW-NH

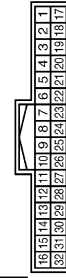

Terminal No.	Color of Wire	Signal Name [Specification]
1	W	-
2	BG	-
5	V	- [With Climate controlled seat]
6	L	- [With heated seat]
8	P	- [With Climate controlled seat]
8	GR	- [With heated seat]

7	SB	-
10	G	- [With Climate controlled seat]
10	GR	- [With heated seat]
11	L	- [With Climate controlled seat]
11	BG	- [With heated seat]
12	Y	-
13	W	-
14	L	-
15	G	-
16	Y	-
17	Y	- [With Climate controlled seat]
17	P	- [With heated seat]
18	BR	-
19	GR	-
20	B	-
21	R	-
22	W	- [With Climate controlled seat]
22	B	- [With heated seat]
23	BG	-
24	V	-
25	LG	- [With Climate controlled seat]
25	B	- [With heated seat]
26	SB	- [With Climate controlled seat]
26	R	- [With heated seat]
27	P	- [With Climate controlled seat]
27	B	- [With heated seat]
28	B	-
29	B	-
30	Y	-
32	L	-



Connector No.	M201
Connector Name	WIRE TO WIRE
Connector Type	TH32MW-NH

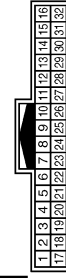

Terminal No.	Color of Wire	Signal Name [Specification]
1	Y	-
2	BG	-
5	V	-
6	P	-
7	SB	-
10	G	-

11	L	-
12	R	-
13	W	-
14	L	-
15	G	-
16	Y	-
17	W	-
18	BR	-
19	GR	-
20	B	-
21	R	-
22	B	-
23	BG	-
24	V	-
25	B	-
26	R	-
27	B	- [With Climate controlled seat]
27	R	- [With heated seat]
28	B	-
29	B	-
30	B	-
32	R	-

Connector No.	M204
Connector Name	CLIMATE CONTROLLED SEAT SWITCH (DRIVER SIDE)
Connector Type	TK(GFW)



Terminal No.	Color of Wire	Signal Name [Specification]
1	BG	-
2	V	-
3	P	-
4	BR	-
5	GR	-
6	B	-
7	R	-
8	B	-

CLIMATE CONTROLLED SEAT SYSTEM

< WIRING DIAGRAM >

A
B
C
D
E
F
G
H
I
SE
K
L
M
N
O
P

CLIMATE CONTROLLED SEAT	
Connector No.	M205
Connector Name	CLIMATE CONTROLLED SEAT SWITCH (PASSENGER SIDE)
Connector Type	TKGBFR



Terminal No.	Color of Wire	Signal Name (Specification)
1	SB	-
2	G	-
3	L	-
4	BG	-
5	V	-
6	B	-
7	R	-
8	B	-

JCJWA1248GB

HEATED SEAT SYSTEM

< WIRING DIAGRAM >

HEATED SEAT SYSTEM

Wiring Diagram

INFOID:000000005986779

*: This connector is not shown in "Harness Layout".

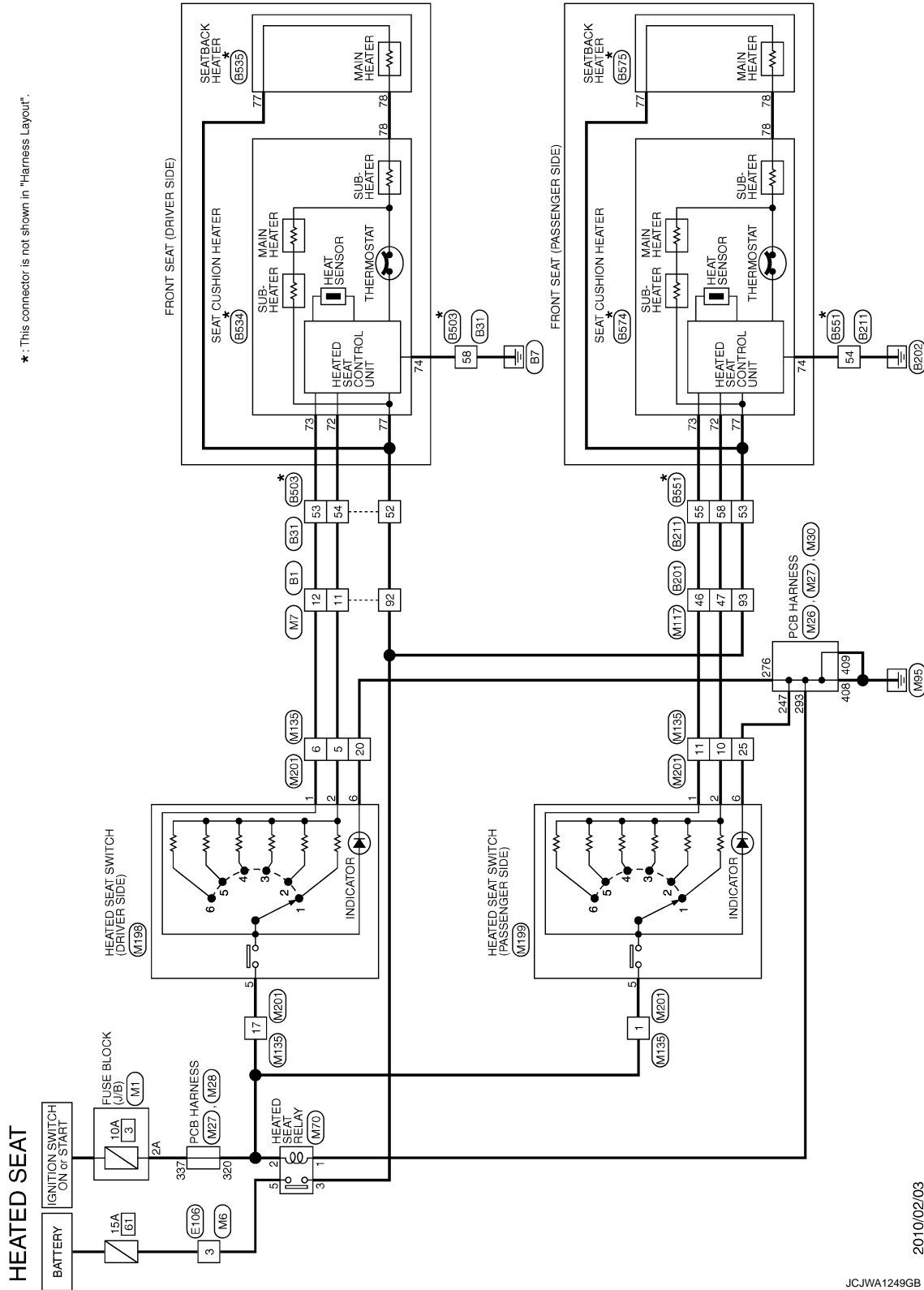

2010/02/03

JCJWA1249GB

HEATED SEAT SYSTEM

< WIRING DIAGRAM >

HEATED SEAT

Connector No.	B1
Connector Name	WIRE TO WIRE
Connector Type	THBDPW-CS16-TM4



Terminal No.	Color of Wire	Signal Name [Specification]
1	R	-
2	W	-
4	LG	-
5	P	-
6	V	-
7	GR	-
8	Y	-
9	LG	-
10	V	-
11	GR	- [With Climate controlled seat]
11	L	- [With heated seat]
12	P	- [With Climate controlled seat]
12	GR	- [With heated seat]
13	BR	-
14	R	-
15	O	-
16	V	-
17	B	-
18	R	-
19	W	-
20	R	-
21	B	-
22	LG	-
23	V	-
24	Y	-
25	G	-
26	GR	-
27	SB	-
28	P	- [With Pre-crash seat belt system]
28	L/O	- [Without Pre-crash seat belt system]
29	L	- [With Pre-crash seat belt system]
29	W/L	- [Without Pre-crash seat belt system]
30	SHIELD	-
32	L	-
33	R	-
34	L	-
35	R	-
36	G	-

37	SB	-
40	SHIELD	-
41	GR/V	-
42	W/L	-
45	W	-
47	O	-
48	Y	-
49	BR	-
50	SB	-
51	V	-
52	LG	-
53	G	-
56	P	-
57	BR	-
58	LG	-
59	Y	-
60	W	-
61	B	-
62	LG	-
63	BR	- [With ICC and 4WAS system]
63	V	- [Without ICC and 4WAS system]
65	O	-
66	BR	-
67	V	-
68	LG	-
68	GR	-
70	R	-
72	L	-
73	P	-
74	L	-
75	P	-
76	Y	-
77	R	-
78	W	-
79	G	-
81	LG	-
82	BR	-
83	SB	-
84	Y	-
85	W	-
86	R	-
87	G	-
88	GR	-
91	SB	-
92	G	-
96	Y	-
97	O	-
98	SB	-
99	LG	-

Connector No.	B31
Connector Name	WIRE TO WIRE
Connector Type	NS12FW-CS

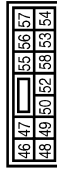

Terminal No.	Color of Wire	Signal Name [Specification]
46	L	-
47	B/W	-
48	SHIELD	-
49	B/R	-
50	BR	-
52	O	- [With Climate controlled seat]
52	G	- [With heated seat]
53	BR	- [With Climate controlled seat]
53	GR	- [With heated seat]
54	P	- [With Climate controlled seat]
54	L	- [With heated seat]
55	G	-
56	GR	-
57	R	-
58	B	-

JCJWA1250GB

A
B
C
D
E
F
G
H
I
SE
K
L
M
N
O
P

HEATED SEAT SYSTEM

< WIRING DIAGRAM >

HEATED SEAT

Connector No.	B201
Connector Name	WIRE TO WIRE
Connector Type	TH80MW-CS16-1M4

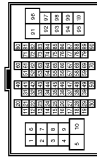

Terminal No.	Color of Wire	Signal Name [Specification]
3	R	-
17	GR	-
18	P	-
19	BR	-
20	GR	-
21	Y	-
22	GR	-
23	R	-
24	V	-
25	B	-
26	W	-
27	O	-
28	V	-
29	P	-
30	O	-
31	B/R	-
32	Y	-
40	SHIELD	-
41	W/R	-
42	V	-
44	P	-
45	SB	-
46	R	- [With Climate controlled seat]
47	G	- [With Climate controlled seat]
48	V	- [With Climate controlled seat]
49	O	-
50	R	-
51	GR	-
52	LG	-
53	P	-
56	P	-
57	W	-
58	O	-
59	Y	-
63	SB	-
82	L	-

63	W	-
66	L	-
67	Y	-
68	SB	-
69	R	-
70	P	-
76	SHIELD	-
77	G	- [With Climate controlled seat]
78	R	- [With heated seat]
79	P	-
80	G	-
81	P	-
82	BR	-
83	GR	-
84	V	-
85	LG	-
86	W	-
87	O	-
88	Y	-
89	BR	-
90	L	-
91	BR	-
93	Y	- [With Climate controlled seat]
93	O	- [With heated seat]
94	GR	-
96	W	-
97	P	-
98	LG	-
99	LG	-
100	Y	-

Connector No.	B211
Connector Name	WIRE TO WIRE
Connector Type	TK10FW-NSS



Terminal No.	Color of Wire	Signal Name [Specification]
1	BR	-
2	B	-
35	G	-
40	L	-
41	P	-
46	Y	-

47	BR	-
48	SHIELD	-
49	L	-
50	B/W	-
52	SB	-
53	O	-
54	R	- [With Climate controlled seat]
54	B	- [With heated seat]
55	Y	-
56	G	-
57	V	-
58	B	- [With Climate controlled seat]
58	GR	- [With heated seat]

Connector No.	B503
Connector Name	WIRE TO WIRE
Connector Type	NS12ZMY-CS



Terminal No.	Color of Wire	Signal Name [Specification]
46	R	-
47	G	-
48	R/Y	-
49	P	-
50	L	-
52	L/B	- [With Climate controlled seat]
52	R	- [With heated seat]
53	Y/W	- [With Climate controlled seat]
53	LG/R	- [With heated seat]
54	Y	- [With Climate controlled seat]
54	LG/B	- [With heated seat]
55	G/R	-
56	V	-
57	B/P	-
58	B	-

Connector No.	B534
Connector Name	SEAT CUSHION HEATER
Connector Type	NS10FW-CS



Terminal No.	Color of Wire	Signal Name [Specification]
72	LG/B	-
73	LG/R	-
74	B	-
77	R	-
78	LG/Y	-

Connector No.	B535
Connector Name	SEATBACK HEATER
Connector Type	NS10ZFW-CS



Terminal No.	Color of Wire	Signal Name [Specification]
77	R/W	-
78	LG/Y	-

HEATED SEAT SYSTEM

< WIRING DIAGRAM >

HEATED SEAT

Connector No.	B551
Connector Name	WIRE TO WIRE
Connector Type	TK0MW-NSB



3A	50	49	57	40	1	41	35	48	47	46
56	58	55	54	53	2	52	1			

Terminal No.	Color of Wire	Signal Name [Specification]
1	R	-
2	B	-
35	W/Y	-
40	W/G	-
41	GR	-
46	R	-
47	G	-
48	R/Y	-
49	P	-
50	L	-
52	L/B	- [With Climate controlled seat]
53	Y/W	- [With Climate controlled seat]
54	R/W	- [With heated seat]
55	Y	- [With heated seat]
54	B/W	- [With Climate controlled seat]
55	G/R	- [With heated seat]
55	LG/R	- [With Climate controlled seat]
56	V	- [With heated seat]
57	B/P	-
58	B/W	- [With Climate controlled seat]
58	LG/B	- [With heated seat]

Connector No.	B574
Connector Name	SEAT CUSHION HEATER
Connector Type	NS08FW-CS



72	77	74	73
----	----	----	----

Terminal No.	Color of Wire	Signal Name [Specification]
72	LG/B	-

73	LG/R	-
74	B/W	-
77	R/W	-
78	LG/Y	-



Connector No.	B575
Connector Name	SEATBACK HEATER
Connector Type	NS02FW-CS



78	77
----	----

Terminal No.	Color of Wire	Signal Name [Specification]
77	R/W	-
78	LG/Y	-

Connector No.	E108
Connector Name	WIRE TO WIRE
Connector Type	TH80FW-CS16-TM4



1	2	3	4	5	6	7	8	9	10	11	12	13	14	15	16	17	18	19	20	21	22	23	24	25	26	27	28	29	30	31	32	33	34	35	36	37	38	39	40	41	42	43	44	45	46	47	48	49	50	51	52	53	54	55	56	57	58	59	60	61	62	63	64	65	66	67	68	69	70	71	72	73	74	75	76	77	78	79	80	81	82	83	84	85	86	87	88	89	90	91	92	93	94	95	96
---	---	---	---	---	---	---	---	---	----	----	----	----	----	----	----	----	----	----	----	----	----	----	----	----	----	----	----	----	----	----	----	----	----	----	----	----	----	----	----	----	----	----	----	----	----	----	----	----	----	----	----	----	----	----	----	----	----	----	----	----	----	----	----	----	----	----	----	----	----	----	----	----	----	----	----	----	----	----	----	----	----	----	----	----	----	----	----	----	----	----	----	----	----	----	----

Terminal No.	Color of Wire	Signal Name [Specification]
1	P	-
2	W	-
3	SB	-
4	LG	-
5	O	-
7	GR	-
8	G	-
9	Y	-
10	BR	-
11	SB	-
12	V	-
13	GR	-
14	GR	-
15	V	-

16	Y	-
17	GR	-
18	V	-
20	BR	-
21	P	-
22	L	-
23	P	-
27	SHIELD	-
28	L/O	-
29	W/L	-
31	BR	-
32	G	-
33	O	-
34	Y	-
40	BR	-
41	BR	-
42	L	-
43	P	-
44	W	-
45	L	-
46	GR	-
47	V	-
48	G	-
49	O	-
50	LG	-
60	W	-
61	C	-
62	Y	-
63	BR	-
64	B	-
65	Y	-
66	R	-
67	SB	-
77	O	-
78	SB	-
80	G	-
81	R	-
82	SB	-
83	GR	-
84	Y	-
85	Y	-
86	L	-
87	V	-
88	BR	-
89	LG	-
90	W	-
91	W	-
92	P	-
93	LG	-
94	BR	-
95	W	-
96	R	-

97	R	-
98	Y	-
99	V	-
100	V	-

Connector No.	M1
Connector Name	FUSE BLOCK (J/B)
Connector Type	NS08FW-M2



3A	2A	1A
8A	7A	6A
5A	4A	3A

Terminal No.	Color of Wire	Signal Name [Specification]
1A	R	-
2A	W	-
3A	Y	-
4A	W	-
5A	V	-
6A	Y	-
8A	Y	-

A
B
C
D
E
F
G
H
I
SE
K
L
M
N
O
P

HEATED SEAT SYSTEM

< WIRING DIAGRAM >

HEATED SEAT

Connector No.	M16
Connector Name	WIRE TO WIRE
Connector Type	TH80MW-CS16-TM4



Terminal No.	Color of Wire	Signal Name [Specification]
1	W	-
2	W	-
3	SB	-
4	LG	-
5	W	-
7	BG	-
8	G	-
9	Y	-
10	W	-
11	R	-
12	V	-
13	LG	-
14	V	-
15	V	-
16	B	-
17	GR	-
18	SB	-
19	Y	-
20	LG	-
21	V	-
22	BG	-
23	W	-
24	Y	-
25	G	-
26	BG	-
27	SB	-
28	Y	-
29	W	-
30	R	-
31	B	-
32	GR	-
33	R	-
34	W	-
35	W	-
36	BR	-
37	L	-
23	P	-
27	SHIELD	-
28	V	-
29	SB	-
31	BG	-
32	P	-
33	R	-
34	BG	-
40	BR	-
41	BR	-
42	L	-
43	P	-
44	BR	-
45	Y	-
46	BG	-
47	V	-
48	G	-
49	BG	-

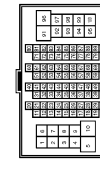

Connector No.	M7
Connector Name	WIRE TO WIRE
Connector Type	TH80MW-CS16-TM4

63	BR	-
65	W	-
66	R	-
67	V	-
68	LG	-
69	SB	-
70	V	-
72	L	-
73	P	-
74	L	-
75	P	-
76	G	-
77	Y	-
78	SB	-
79	W	-
81	LG	-
82	BR	-
83	BG	-
84	B	-
85	W	-
86	G	-
87	R	-
88	G	-
91	W	-
92	G	-
96	W	-
97	BG	-
98	Y	-
99	LG	-

6	W	-
7	G	-
8	Y	-
9	G	-
10	V	-
11	V	- [With Climate controlled seat]
12	P	- [With Heated seat]
13	GR	- [With Climate controlled seat]
14	BR	- [With Heated seat]
15	BG	-
16	V	-
17	BG	- [With ICC]
18	L	- [Without ICC]
19	W	-
20	R	-
21	B	-
22	LG	-
23	W	-
24	V	-
25	G	-
26	BR	-
27	SB	-
28	P	-
29	L	-
30	SHIELD	-
32	L	-
33	P	-
34	L	-
35	P	-
36	BG	-
37	SB	-
40	SHIELD	-
41	SB	-
42	V	-
45	W	-
47	L	-
48	LG	-
49	BR	-
50	V	-
51	V	-
52	P	-
53	BG	-
56	SB	-
57	P	-
58	LG	-
59	Y	-
60	GR	-
61	B	-
62	LG	-

50	W	-
60	GR	-
61	B	-
62	LG	-
63	BR	-
64	L	-
65	R	-
66	P	-
67	L	-
77	B	-
78	V	-
80	G	-
81	L	-
82	B	-
83	BG	-
84	SB	-
85	Y	-
86	L	-
87	V	-
88	V	-
89	LG	-
90	BG	-
91	W	-
92	BG	-
93	G	-
94	Y	-
95	W	-
96	R	-
97	SB	-
98	R	-
99	W	-
100	L	-

Terminal No.	Color of Wire	Signal Name [Specification]
1	G	-
2	Y	-
4	BR	-
3	P	-

HEATED SEAT SYSTEM

< WIRING DIAGRAM >

HEATED SEAT

Connector No.	M26
Connector Name	POB HARNESS
Connector Type	TH40FW-NH

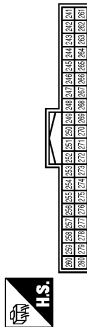

Terminal No.	Color of Wire	Signal Name [Specification]
241	L	-
243	R	-
244	L	-
245	B	-
246	B	-
247	LG	- [With Climate controlled seat]
249	B	- [With heated seat]
249	SHIELD	-
253	P	- [With Climate controlled seat]
253	B	- [With heated seat]
254	W	- [With Climate controlled seat]
254	B	- [With heated seat]
255	B	- [With heated seat]
256	SHIELD	-
257	SHIELD	-
258	R	-
259	L	-
260	BG	-
261	P	-
269	GR	-
270	Y	-
271	BR	-
272	G	-
273	R	-
274	R	-
275	Y	-
276	B	-
277	G	-
278	R	-
279	SB	- [With Climate controlled seat]
279	R	- [With heated seat]
280	Y	-

Connector No.	M27
Connector Name	POB HARNESS
Connector Type	TH40FB-NH

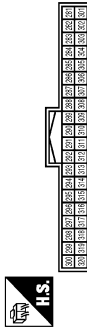

Terminal No.	Color of Wire	Signal Name [Specification]
282	BG	-
283	BG	-
284	LG	-
286	W	-
287	Y	-
288	W	-
290	B	-
292	B	-
293	B	-
294	B	-
295	B	-
299	V	-
301	R	-
302	R	-
303	R	-
319	V	-
320	W	-

Connector No.	M28
Connector Name	POB HARNESS
Connector Type	TH40FW-NH

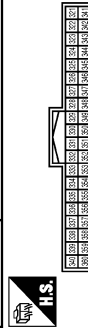

Terminal No.	Color of Wire	Signal Name [Specification]
321	V	-
322	V	-
324	B	-
325	L	-
326	L	-

327	P	-
328	P	-
330	B	-
331	V	-
332	Y	-
333	B	-
337	W	-
338	W	-
343	L	-
344	B	-
345	Y	-
346	L	-
347	P	-
348	GR	-
349	V	-
350	LG	-
351	P	-
352	R	-
353	P	-
358	W	-
359	W	-
360	G	-

Connector No.	M80
Connector Name	POB HARNESS
Connector Type	TH40FW-NH

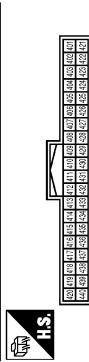

Terminal No.	Color of Wire	Signal Name [Specification]
402	R	-
403	R	-
407	V	-
408	B	-
409	B	-
410	B	-
411	B	-
413	Y	-
414	BR	-
416	LG	-
417	B	-
419	SB	-
420	SHIELD	-
422	V	-

427	P	-
428	V	-
429	P	-
430	LG	-
431	B	-
432	V	-
435	V	-
436	BG	-
437	B	-
438	P	-
439	L	-

Connector No.	M70
Connector Name	HEATED SEAT RELAY
Connector Type	MS02FL-M2-LC

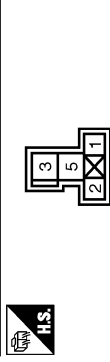

Terminal No.	Color of Wire	Signal Name [Specification]
1	B	-
2	W	-
3	G	-
5	SB	-

A B C D E F G H I SE K L M N O P

HEATED SEAT SYSTEM

< WIRING DIAGRAM >

HEATED SEAT

Connector No.	M117
Connector Name	WIRE TO WIRE
Connector Type	TH3DFW-CS16-TM4



Terminal No.	Color of Wire	Signal Name [Specification]
3	Y	-
17	GR	-
18	P	-
19	BR	-
20	GR	-
21	Y	-
22	LG	-
23	R	-
24	BG	-
25	LG	-
26	W	-
27	R	-
28	V	-
29	P	-
30	B	-
31	G	-
32	Y	-
40	SHIELD	-
41	R	-
42	V	-
44	W	-
45	SB	-
46	L	- [With Climate controlled seat] - [With heated seat]
47	G	- [With Climate controlled seat]
47	GR	- [With Climate controlled seat]
48	V	-
49	BG	-
50	LG	-
51	SB	-
52	Y	-
53	W	-
56	B	-
57	G	-
58	R	-
59	W	-
61	LG	-
62	V	-

63	R	-
66	L	-
67	Y	-
68	SB	-
69	BR	-
70	P	-
76	SHIELD	-
77	G	-
78	R	-
79	L	-
80	G	-
81	BG	-
82	BR	-
83	GR	-
84	V	-
85	LG	-
86	V	-
87	R	-
88	Y	-
89	BR	-
90	L	-
91	Y	-
93	W	- [With Climate controlled seat]
93	G	- [With heated seat]
94	V	-
96	W	-
97	Y	-
98	BR	-
99	G	-
100	Y	-



Connector No.	M135
Connector Name	WIRE TO WIRE
Connector Type	TH32FW-NH



7	SB	-
10	G	- [With Climate controlled seat]
10	GR	- [With heated seat]
11	L	- [With Climate controlled seat]
11	BG	- [With heated seat]
12	V	-
13	W	-
14	L	-
15	G	-
16	Y	-
17	W	- [With Climate controlled seat]
17	P	- [With heated seat]
18	BR	-
19	GR	-
20	B	-
21	R	-
22	W	- [With Climate controlled seat]
22	B	- [With heated seat]
23	BG	-
24	V	-
25	LG	- [With Climate controlled seat]
25	B	- [With heated seat]
26	SB	- [With Climate controlled seat]
26	R	- [With heated seat]
27	P	- [With Climate controlled seat]
27	B	- [With heated seat]
28	B	-
29	B	-
30	Y	-
32	L	-



Connector No.	M158
Connector Name	HEATED SEAT SWITCH (DRIVER SIDE)
Connector Type	TK10FW

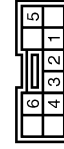

Connector No.	M199
Connector Name	HEATED SEAT SWITCH (PASSENGER SIDE)
Connector Type	TK08FB

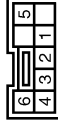

Terminal No.	Color of Wire	Signal Name [Specification]
1	L	-
2	G	-
3	R	-
4	R	-
5	Y	-
6	B	-

JCJWA1255GB

HEATED SEAT SYSTEM

< WIRING DIAGRAM >

A
B
C
D
E
F
G
H
I
SE
K
L
M
N
O
P

HEATED SEAT

Connector No.	M201
Connector Name	WIRE TO WIRE
Connector Type	TH2/MW-NH



1	2	3	4	5	6	7	8	9	10	11	12	13	14	15	16	17	18	19	20	21	22	23	24	25	26	27	28	29	30	31	32
---	---	---	---	---	---	---	---	---	----	----	----	----	----	----	----	----	----	----	----	----	----	----	----	----	----	----	----	----	----	----	----

Terminal No.	Color of Wire	Signal Name (Specification)
1	Y	-
2	BG	-
5	V	-
6	P	-
7	SB	-
10	G	-
11	L	-
12	R	-
13	W	-
14	L	-
15	G	-
16	Y	-
17	W	-
18	BR	-
19	GR	-
20	B	-
21	R	-
22	B	-
23	BG	-
24	V	-
25	B	-
26	R	-
27	B	- [With Climate controlled seat]
28	B	- [With heated seat]
29	B	-
30	B	-
32	R	-

JCJWA1256GB

DIAGNOSIS AND REPAIR WORK FLOW

< BASIC INSPECTION >

BASIC INSPECTION

DIAGNOSIS AND REPAIR WORK FLOW

Work Flow

INFOID:000000005986782

DETAILED FLOW

1.OBTAIN INFORMATION ABOUT SYMPTOM

Interview the customer to obtain the malfunction information (conditions and environment when the malfunction occurred) as much as possible when the customer brings the vehicle in.

>> GO TO 2.

2.REPRODUCE THE MALFUNCTION INFORMATION

Check the malfunction on the vehicle that the customer describes.
Inspect the relation of the symptoms and the condition when the symptoms occur.

>> GO TO 3.

3.IDENTIFY THE MALFUNCTIONING SYSTEM WITH "SYMPTOM DIAGNOSIS"

Use "Symptom diagnosis" from the symptom inspection result in step 2 and then identify where to start performing the diagnosis based on possible causes and symptoms.

>> GO TO 4.

4.IDENTIFY THE MALFUNCTIONING PARTS WITH "COMPONENT DIAGNOSIS"

Perform the diagnosis with "Component diagnosis" of the applicable system.

>> GO TO 5.

5.REPAIR OR REPLACE THE MALFUNCTIONING PARTS

Repair or replace the specified malfunctioning parts.

>> GO TO 6.

6.FINAL CHECK

Check that malfunctions are not reproduced when obtaining the malfunction information from the customer, referring to the symptom inspection result in step 2.

Are the malfunctions corrected?

YES >> INSPECTION END
NO >> GO TO 3.

POWER SUPPLY AND GROUND CIRCUIT

< DTC/CIRCUIT DIAGNOSIS >

DTC/CIRCUIT DIAGNOSIS

POWER SUPPLY AND GROUND CIRCUIT CLIMATE CONTROLLED SEAT CONTROL UNIT

CLIMATE CONTROLLED SEAT CONTROL UNIT : Diagnosis Procedure INFOID:000000006007965

Driver side

1. CHECK FUSE

Check that the following fuse and fusible link are not fusing.

Signal name	Fuse No.
Ignition power supply	3 (10 A)
Battery power supply	61 (15 A)

Is the inspection result normal?

YES >> GO TO 2.

NO >> Replace the blown fuse after repairing the affected circuit.

2. CHECK CLIMATE CONTROLLED SEAT CONTROL UNIT (DRIVER SIDE) POWER SUPPLY

1. Turn ignition switch OFF.
2. Disconnect climate controlled seat control unit (driver side) connector.
3. Turn ignition switch ON.
4. Check voltage between climate controlled seat control unit (driver side) harness connector and ground.

(+)		(-)	Voltage (V) (Approx.)
Connector	Terminal		
B528	55	Ground	Battery voltage
B529	63		

Is the inspection result normal?

YES >> GO TO 3.

NO >> GO TO 4.

3. CHECK CLIMATE CONTROLLED SEAT CONTROL UNIT (DRIVER SIDE) GROUND CIRCUIT

1. Turn ignition switch OFF.
2. Check continuity between climate control unit (driver side) harness connector and ground.

Climate controlled seat control unit (driver side)		Ground	Continuity
Connector	Terminal		
B528	58		Existed

Is the inspection result normal?

YES >> INSPECTION END

NO >> Repair or replace harness.

4. CHECK CLIMATE CONTROLLED SEAT CONTROL UNIT (DRIVER SIDE) POWER SUPPLY CIRCUIT

1. Turn ignition switch OFF.
2. Disconnect climate controlled seat relay.
3. Check continuity between climate controlled seat control unit (driver side) harness connector and climate controlled seat relay harness connector.

POWER SUPPLY AND GROUND CIRCUIT

< DTC/CIRCUIT DIAGNOSIS >

Climate controlled seat control unit (driver side)		Climate controlled seat relay		Continuity
Connector	Terminal	Connector	Terminal	
B528	55	M61	6	Existed
B529	63			

4. Check continuity between climate controlled seat control unit (driver side) harness connector and ground.

Climate controlled seat control unit (driver side)		Ground	Continuity
Connector	Terminal		
B528	55	Ground	Not existed
B529	63		

Is the inspection result normal?

YES >> GO TO 5.

NO >> Repair or replace harness.

5. CHECK CLIMATE CONTROLLED SEAT RELAY POWER SUPPLY

- Turn ignition switch ON.
- Check voltage between climate controlled seat relay harness connector and ground.

Climate controlled seat relay (+)		Ground (-)	Voltage (V) (Approx.)
Connector	Terminal		
M61	2	Ground	Battery voltage
	7		

Is the inspection result normal?

YES >> GO TO 6.

NO >> Repair or replace harness.

6. CHECK CLIMATE CONTROLLED SEAT RELAY GROUND CIRCUIT

- Turn ignition switch OFF.
- Check continuity between climate controlled seat relay harness connector and ground.

Climate controlled seat relay		Ground	Continuity
Connector	Terminal		
M61	1	Ground	Existed

Is the inspection result normal?

YES >> GO TO 7.

NO >> Repair or replace harness.

7. CHECK CLIMATE CONTROLLED SEAT RELAY

Check climate controlled seat relay.

Refer to [SE-56, "CLIMATE CONTROLLED SEAT CONTROL UNIT : Component Inspection"](#).

Is the inspection result normal?

YES >> GO TO 8.

NO >> Replace climate controlled seat relay.

8. CHECK INTERMITTENT INCIDENT

Refer to [GI-38, "Intermittent Incident"](#).

>> INSPECTION END

Passenger side

1. CHECK FUSE

POWER SUPPLY AND GROUND CIRCUIT

< DTC/CIRCUIT DIAGNOSIS >

Check that the following fuse and fusible link are not fusing.

Signal name	Fuse No.
Ignition power supply	3 (10 A)
Battery power supply	62 (15 A)

Is the fuse fusing?

YES >> Replace the blown fuse after repairing the affected circuit.

NO >> GO TO 2.

2. CHECK CLIMATE CONTROLLED SEAT CONTROL UNIT (PASSENGER SIDE) POWER SUPPLY

- Turn ignition switch OFF.
- Disconnect climate controlled seat control unit (passenger side) connector.
- Turn ignition switch ON.
- Check voltage between climate controlled seat control unit (passenger side) harness connector and ground.

(+)		(-)	Voltage (V) (Approx.)
Climate controlled seat control unit (passenger side)			
Connector	Terminal	Ground	Battery voltage
B558	55		
B559	63		

Is the inspection result normal?

YES >> GO TO 3.

NO >> GO TO 4.

3. CHECK CLIMATE CONTROLLED SEAT CONTROL UNIT (PASSENGER SIDE) GROUND CIRCUIT

- Turn ignition switch OFF.
- Check continuity between harness connector and ground.

Climate controlled seat control unit (passenger side)		Ground	Continuity
Connector	Terminal		
B558	58		Existed

Is the inspection result normal?

YES >> INSPECTION END

NO >> Repair harness or connector.

4. CHECK CLIMATE CONTROLLED SEAT CONTROL UNIT (PASSENGER SIDE) POWER SUPPLY CIRCUIT

- Turn ignition switch OFF.
- Disconnect climate controlled seat relay.
- Check continuity between climate controlled seat control unit (passenger side) harness connector and climate controlled seat relay harness connector.

Climate controlled seat control unit (passenger side)		Climate controlled seat relay		Continuity
Connector	Terminal	Connector	Terminal	
B558	55	M61	3	Existed
B559	63			

- Check continuity between climate controlled seat control unit (passenger side) harness connector and ground.

POWER SUPPLY AND GROUND CIRCUIT

< DTC/CIRCUIT DIAGNOSIS >

Climate controlled seat control unit (passenger side)		Ground	Continuity
Connector	Terminal		
B558	55		
B559	63		Not existed

Is the inspection result normal?

YES >> GO TO 5.

NO >> Repair or replace harness.

5. CHECK CLIMATE CONTROLLED SEAT RELAY POWER SUPPLY

1. Turn ignition switch ON.
2. Check voltage between climate controlled seat relay harness connector and ground.

(+)		(-)	Voltage (V) (Approx.)
Climate controlled seat relay			
Connector	Terminal		
M61	2	Ground	Battery voltage
	5		

Is the inspection result normal?

YES >> GO TO 6.

NO >> Repair or replace harness.

6. CHECK CLIMATE CONTROLLED SEAT RELAY GROUND CIRCUIT

1. Turn ignition switch OFF.
2. Check continuity between climate controlled seat relay harness connector and ground.

Climate controlled seat relay		Ground	Continuity
Connector	Terminal		
M61	1		

Is the inspection result normal?

YES >> GO TO 7.

NO >> Repair or replace harness.

7. CHECK CLIMATE CONTROLLED SEAT RELAY

Check climate controlled seat relay.

Refer to [SE-56, "CLIMATE CONTROLLED SEAT CONTROL UNIT : Component Inspection"](#).

Is the inspection result normal?

YES >> GO TO 8.

NO >> Replace climate controlled seat relay.

8. CHECK INTERMITTENT INCIDENT

Refer to [GI-38, "Intermittent Incident"](#).

>> INSPECTION END

CLIMATE CONTROLLED SEAT CONTROL UNIT : Component Inspection INFOID:000000006007966

1. CHECK CLIMATE CONTROLLED SEAT RELAY

1. Turn ignition switch OFF.
2. Remove climate controlled seat relay.

POWER SUPPLY AND GROUND CIRCUIT

< DTC/CIRCUIT DIAGNOSIS >

3. Check continuity between climate controlled seat relay terminals under the following conditions.

Terminal	Condition	Continuity
3	12 V direct current supply between terminals 1 and 2.	Existed
	No current supply	Not existed
6	12 V direct current supply between terminals 1 and 2.	Existed
	No current supply	Not existed

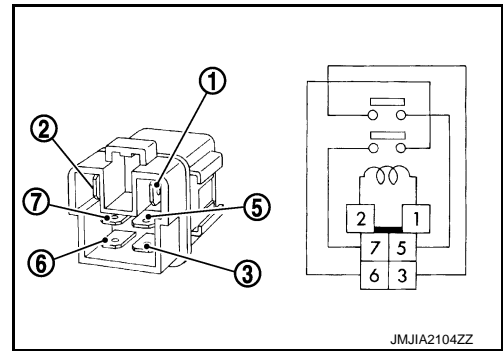

Is the inspection result normal?

- YES >> INSPECTION END
 NO >> Replace climate controlled seat relay.

SEAT CUSHION HEATER

SEAT CUSHION HEATER : Diagnosis Procedure

INFOID:000000005986788

1. CHECK FUSE

Check that the following fuse and fusible link are not fusing.

Signal name	Fuse No.
Battery power supply	61 (15 A)

Is the inspection result normal?

- YES >> GO TO 2.
 NO >> Replace the blown fuse after repairing the affected circuit.

2. CHECK SEAT CUSHION HEATER POWER SUPPLY

- Turn ignition switch OFF.
- Disconnect seat cushion heater connector.
- Turn ignition switch ON.
- Check voltage between seat cushion heater harness connector and ground.

(+)		Terminal	(-)	Voltage (V) (Approx.)
Seat cushion heater				
Connector				
Driver side	B534	77	Ground	Battery voltage
Passenger side	B574			

Is the inspection result normal?

- YES >> GO TO 4.
 NO >> GO TO 3.

3. CHECK SEAT CUSHION HEATER POWER SUPPLY CIRCUIT

- Turn ignition switch OFF.
- Disconnect heated seat relay.
- Check continuity between seat cushion heater harness connector and heated seat relay terminal connector.

Seat cushion heater		Heated seat relay		Continuity
Connector	Terminal	Connector	Terminal	
Driver side	B534	M70	3	Existed
Passenger side	B574			

- Check continuity between seat cushion heater harness connector and ground.

POWER SUPPLY AND GROUND CIRCUIT

< DTC/CIRCUIT DIAGNOSIS >

Seat cushion heater		Terminal	Ground	Continuity
Connector				Continuity
Driver side	B534	77		Not existed
Passenger side	B574			

Is the inspection result normal?

YES >> Repair or replace harness between heated seat relay and fuse holder.

NO >> Repair or replace harness between seat cushion heater and heated seat relay.

4. CHECK HEATED SEAT OPERATION SIGNAL

Check voltage between seat cushion heater harness connector and ground.

(+)		Terminal	(-)	Condition	Voltage (V) (Approx.)	
Seat cushion heater						
Connector		Terminal				
Driver side	B534	73	Ground	Heated seat switch	ON	Battery voltage
					OFF	0
Passenger side	B574				ON	Battery voltage
					OFF	0

Is the inspection result normal?

YES >> GO TO 7.

NO >> GO TO 5.

5. CHECK HEATED SEAT OPERATION SIGNAL CIRCUIT

1. Turn ignition switch OFF.
2. Disconnect heated seat switch connector.
3. Check continuity between seat cushion heater harness connector and heated seat switch harness connector.

Seat cushion heater		Terminal	Heated seat switch		Continuity
Connector			Connector	Terminal	
Driver side	B534	73	M198	1	Existed
Passenger side	B574		M199		

4. Check continuity between seat cushion heater harness connector and ground.

Seat cushion heater		Terminal	Ground	Continuity
Connector				Continuity
Driver side	B534	73		Not existed
Passenger side	B574			

Is the inspection result normal?

YES >> GO TO 6.

NO >> Repair or replace harness.

6. CHECK HEATED SEAT SWITCH

Check heated seat switch.

Refer to [SE-80. "Component Inspection"](#).

Is the inspection result normal?

YES >> GO TO 8.

NO >> Replace heated seat switch.

7. CHECK SEAT CUSHION HEATER GROUND CIRCUIT

1. Turn ignition switch OFF.
2. Check continuity between seat cushion heater harness connector and ground.

POWER SUPPLY AND GROUND CIRCUIT

< DTC/CIRCUIT DIAGNOSIS >

Seat cushion heater		Terminal	Ground	Continuity
Connector				Continuity
Driver side	B534	74	Ground	Exists
Passenger side	B574			

Is the inspection result normal?

- YES >> INSPECTION END
 NO >> Repair or replace harness.

8.CHECK INTERMITTENT INCIDENT

Check intermittent incident.
 Refer to [GI-38, "Intermittent Incident"](#).

>> INSPECTION END

SEATBACK HEATER

SEATBACK HEATER : Diagnosis Procedure

INFOID:000000006100109

1.CHECK SEATBACK HEATER POWER SUPPLY

1. Turn ignition switch OFF.
2. Disconnect seatback heater connector.
3. Turn ignition switch ON.
4. Check voltage between seatback heater harness connector and ground.

(+)		Terminal	(-)	Voltage (V) (Approx.)
Seatback heater				
Connector		Terminal		
Driver side	B535	77	Ground	Battery voltage
Passenger side	B575			

Is the inspection result normal?

- YES >> INSPECTION END
 NO >> GO TO 2.

2.CHECK SEATBACK HEATER POWER SUPPLY CIRCUIT

1. Turn ignition switch OFF.
2. Disconnect heated seat relay.
3. Check continuity between seatback heater harness connector and heated seat relay terminal connector.

Seatback heater		Terminal	Heated seat relay		Continuity
Connector			Connector	Terminal	
Driver side	B535	77	M70	3	Existed
Passenger side	B575				

4. Check continuity between seatback heater harness connector and ground.

Seatback heater		Terminal	Ground	Continuity
Connector				Continuity
Driver side	B535	77	Ground	Not existed
Passenger side	B575			

Is the inspection result normal?

- YES >> GO TO 3.
 NO >> Repair or replace harness.

3.CHECK INTERMITTENT INCIDENT

POWER SUPPLY AND GROUND CIRCUIT

< DTC/CIRCUIT DIAGNOSIS >

Check intermittent incident.
Refer to [GI-38, "Intermittent Incident"](#).

>> INSPECTION END

HEATED SEAT SWITCH

HEATED SEAT SWITCH : Diagnosis Procedure

INFOID:000000006008025

1. CHECK FUSE

Check that the following fuse and fusible link are not fusing.

Signal name	Fuse No.
Ignition power supply	3 (10 A)

Is the inspection result normal?

YES >> GO TO 2.

NO >> Replace the blown fuse after repairing the affected circuit.

2. CHECK HEATED SEAT SWITCH POWER SUPPLY

1. Turn ignition switch OFF.
2. Disconnect heated seat switch connector.
3. Turn ignition switch ON.
4. Check voltage between heated seat switch harness connector and ground.

(+)		Terminal	(-)	Voltage (V) (Approx.)
Heated seat switch				
Connector				
Driver side	M198	5	Ground	Battery voltage
Passenger side	M199			

Is the inspection result normal?

YES >> INSPECTION END

NO >> GO TO 3.

3. CHECK HEATED SEAT SWITCH POWER SUPPLY CIRCUIT

1. Turn ignition switch OFF.
2. Disconnect fuse block (J/B) connector.
3. Check continuity between heated seat switch harness connector and fuse block (J/B) harness connector.

Heated seat switch		Fuse block (J/B)		Continuity
Connector	Terminal	Connector	Terminal	
Driver side	M198	M1	2A	Existed
Passenger side	M199			

4. Check continuity between heated seat switch harness connector and ground.

Heated seat switch		Terminal	Ground	Continuity
Connector				
Driver side	M198	5	Ground	Not existed
Passenger side	M199			

Is the inspection result normal?

YES >> GO TO 4.

NO >> Repair or replace harness.

4. CHECK FUSE BLOCK (J/B)

1. Turn ignition switch ON.

POWER SUPPLY AND GROUND CIRCUIT

< DTC/CIRCUIT DIAGNOSIS >

2. Check voltage between fuse block (J/B) connector (fuse block side) and ground.

(+)		(-)	Voltage (V) (Approx.)
Fuse block (J/B)			
Connector	Terminal		
M1	2A	Ground	Battery voltage

Is the inspection result normal?

YES >> GO TO 5.

NO >> Repair or replace fuse block (J/B).

5.CHECK INTERMITTENT INCIDENT

Check intermittent incident.

Refer to [GI-38, "Intermittent Incident"](#).

>> INSPECTION END

A
B
C
D
E
F
G
H
I
K
L
M
N
O
P

SE

CLIMATE CONTROLLED SEAT SWITCH

< DTC/CIRCUIT DIAGNOSIS >

CLIMATE CONTROLLED SEAT SWITCH

Component Function Check

INFOID:000000006007967

1.CHECK CLIMATE CONTROLLED SEAT SWITCH FUNCTION

Check that climate controlled seat activates when operating climate controlled seat control switch.

Is the inspection result normal?

YES >> INSPECTION END

NO >> Refer to [SE-62, "Diagnosis Procedure"](#).

Diagnosis Procedure

INFOID:000000006007968

1.CHECK CLIMATE CONTROLLED SEAT CONTROL UNIT INPUT SIGNAL

1. Turn ignition switch ON.
2. Check voltage between climate controlled seat control unit harness connector and ground.

(+)		(-)	Condition	Voltage (V) (Approx.)					
Climate controlled seat control unit									
Connector	Terminal								
Driver side	B529	56	Climate controlled seat switch (driver side)	COOL	HI	2.6 - 4.2			
					MID	1.6 - 2.5			
					LO	0.8 - 1.5			
				OFF				0	
				HEAT	HI	2.6 - 4.2			
					MID	1.6 - 2.5			
LO	0.8 - 1.5								
OFF				0					
Passenger side	B559	56	Climate controlled seat switch (passenger seat)	COOL	HI	2.6 - 4.2			
					MID	1.6 - 2.5			
					LO	0.8 - 1.5			
				OFF				0	
				HEAT	HI	2.6 - 4.2			
					MID	1.6 - 2.5			
LO	0.8 - 1.5								
OFF				0					

Is the inspection result normal?

YES >> INSPECTION END

NO-1 : HEAT or COOL mode is NG>>GO TO 2.

NO-2 : HEAT and COOL modes are NG>>GO TO 3.

2.CHECK CLIMATE CONTROLLED SEAT SWITCH CIRCUIT

1. Turn ignition switch OFF.
2. Disconnect climate controlled seat switch connector and climate controlled seat control unit connector.
3. Check continuity between climate controlled seat switch harness connector and climate controlled seat control unit harness connector.

CLIMATE CONTROLLED SEAT SWITCH

< DTC/CIRCUIT DIAGNOSIS >

Climate controlled seat switch				Climate controlled seat control unit		Continuity
Connector		Terminal	Connector	Terminal		
Driver side	COOL	M204	2	B529	56	Existed
	HEAT		3		54	
Passenger side	COOL	M205	2	B559	56	
	HEAT		3		54	

4. Check continuity between climate controlled seat switch harness connector and ground.

Climate controlled seat switch				Ground	Continuity
Connector		Terminal			
Driver side	COOL	M204	2	Ground	Not existed
	HEAT		3		
Passenger side	COOL	M205	2		
	HEAT		3		

Is the inspection result normal?

YES >> GO TO 5.

NO >> Repair or replace harness.

3. CHECK CLIMATE CONTROLLED SEAT SWITCH POWER SUPPLY

- Turn ignition switch OFF.
- Disconnect climate controlled seat switch connector.
- Turn ignition switch ON.
- Check voltage between climate controlled seat switch harness connector and ground.

(+)			(-)	Voltage (V) (Approx.)
Climate controlled seat switch				
Connector	Terminal			
Driver side	M204	1	Ground	12
Passenger side	M205			

Is the inspection result normal?

YES >> GO TO 5.

NO >> GO TO 4.

4. CHECK CLIMATE CONTROLLED SEAT SWITCH POWER SUPPLY CIRCUIT

- Turn ignition switch OFF.
- Disconnect climate controlled seat control unit connector.
- Check continuity between climate controlled seat switch harness connector and climate controlled seat control unit harness connector.

Climate controlled seat switch			Climate controlled seat control unit		Continuity
Connector	Terminal	Connector	Terminal		
Driver side	M204	1	B529	52	Existed
Passenger side	M205		B559		

4. Check continuity between climate controlled seat switch harness connector and ground.

Climate controlled seat switch			Ground	Continuity
Connector	Terminal			
Driver side	M204	1	Ground	Not existed
Passenger side	M205			

Is the inspection result normal?

CLIMATE CONTROLLED SEAT SWITCH

< DTC/CIRCUIT DIAGNOSIS >

- YES >> Replace climate controlled seat control unit.
NO >> Repair or replace harness.

5.CHECK CLIMATE CONTROLLED SEAT SWITCH

Check climate controlled seat switch.
Refer to [SE-64, "Component Inspection"](#).

Is the inspection result normal?

- YES >> GO TO 6.
NO >> Replace climate controlled seat switch.

6.CHECK INTERMITTENT INCIDENT

Refer to [GI-38, "Intermittent Incident"](#).

>> INSPECTION END

Component Inspection

INFOID:000000006007969

1.CHECK CLIMATE CONTROLLED SEAT SWITCH

1. Turn ignition switch OFF.
2. Disconnect climate controlled seat switch connector.
3. Check continuity between climate controlled seat switch terminals under the following conditions.

Terminal		Condition		Continuity	
2	1	Climate controlled seat switch	COOL mode	ON	Existed
				OFF	Not existed
HEAT mode			ON	Existed	
			OFF	Not existed	
3					

Is the inspection result normal?

- YES >> INSPECTION END
NO >> Replace climate controlled seat switch.

SEATBACK THERMAL ELECTRIC UNIT

< DTC/CIRCUIT DIAGNOSIS >

SEATBACK THERMAL ELECTRIC UNIT

Component Function Check

INFOID:000000006007970

1. CHECK SEATBACK THERMAL ELECTRIC UNIT FUNCTION

Check whether or not the temperature of the seatback thermal electric unit changes in accordance with the HEAT or COOL switch operation of the climate controlled seat control switch.

Is the inspection result normal?

- YES >> INSPECTION END
 NO >> Refer to [SE-65. "Diagnosis Procedure"](#).

Diagnosis Procedure

INFOID:000000006007971

1. CHECK SEATBACK THERMAL ELECTRIC UNIT INPUT SIGNAL

- Turn ignition switch ON.
- Check voltage between seatback thermal electric unit harness connector and ground.

(+)		(-)	Condition	Voltage (V) (Approx.)	
Seatback thermal electric unit					
Connector	Terminal				
Driver side	B532	Ground	Climate controlled seat switch	HEAT or COOL	0 - 12*
			Other than the above	0	
	Climate controlled seat switch		HEAT or COOL	0 - 12*	
	Other than the above		0		
Passenger side	B562	Ground	Climate controlled seat switch	HEAT or COOL	0 - 12*
			Other than the above	0	
	Climate controlled seat switch		HEAT or COOL	0 - 12*	
	Other than the above		0		

* : It value changes between 12 V and 0 V

NOTE:

Wait 1 minute or more after the activation start, and then start the measurement.

Is the inspection result normal?

- YES >> Replace seatback thermal electric unit.
 NO >> GO TO 2.

2. CHECK SEATBACK THERMAL ELECTRIC UNIT CIRCUIT

- Turn ignition switch OFF.
- Disconnect climate controlled seat control unit connector and seatback thermal electric unit connector.
- Check continuity between climate controlled seat control unit harness connector and seatback thermal electric unit harness connector.

Climate controlled seat control unit		Seatback thermal electric unit		Continuity
Connector	Terminal	Connector	Terminal	
Driver side	B528	B532	59	Existed
			60	
Passenger side	B558	B562	59	
			60	

- Check continuity between climate controlled seat control unit harness connector and ground.

SEATBACK THERMAL ELECTRIC UNIT

< DTC/CIRCUIT DIAGNOSIS >

Climate controlled seat control unit		Terminal	Ground	Continuity
Connector				Continuity
Driver side	B528	59	Ground	Not existed
		60		
Passenger side	B558	59		
		60		

Is the inspection result normal?

YES >> Replace climate controlled seat control unit.

NO >> Repair or replace harness.

SEATBACK THERMAL ELECTRIC UNIT SENSOR

< DTC/CIRCUIT DIAGNOSIS >

SEATBACK THERMAL ELECTRIC UNIT SENSOR

Component Function Check

INFOID:000000006062298

1. CHECK SEATBACK THERMAL ELECTRIC UNIT SENSOR FUNCTION

Check whether or not the temperature of the seatback thermal electric unit changes in accordance with the HEAT or COOL switch operation of the climate controlled seat control switch.

Is the inspection result normal?

- YES >> INSPECTION END
NO >> Refer to [SE-68. "Component Inspection"](#).

Diagnosis Procedure

INFOID:000000006069098

1. CHECK SEATBACK THERMAL ELECTRIC UNIT SENSOR SIGNAL

- Turn ignition switch ON.
- Check voltage between seatback thermal electric unit harness connector and ground.

(+)		Terminal	(-)	Condition	Voltage (V) (Approx.)
Seatback thermal electric unit					
Connector		Terminal			
Driver side	B532	68	Ground	Climate controlled seat operated	1 - 5
Passenger side	B562				

Is the inspection result normal?

- YES >> GO TO 3.
NO >> GO TO 2.

2. CHECK SEATBACK THERMAL ELECTRIC UNIT SENSOR CIRCUIT

- Turn ignition switch OFF.
- Disconnect climate controlled seat control unit connector and seatback thermal electric unit connector.
- Check continuity between climate controlled seat control unit harness connector and seatback thermal electric unit harness connector.

Climate controlled seat control unit		Terminal	Seatback thermal electric unit		Continuity
Connector			Connector	Terminal	
Driver side	B530	68	B532	68	Existed
Passenger side	B560		B562		

- Check continuity between climate controlled seat control unit harness connector and ground.

Climate controlled seat control unit		Terminal	Ground	Continuity
Connector				
Driver side	B530	68		Not existed
Passenger side	B560			

Is the inspection result normal?

- YES >> Replace climate controlled seat control unit.
NO >> Repair or replace harness.

3. CHECK SEATBACK THERMAL ELECTRIC UNIT SENSOR GROUND CIRCUIT

- Turn ignition switch OFF.
- Disconnect climate controlled seat control unit connector and seatback thermal electric unit connector.
- Check continuity between climate controlled seat control unit harness connector and seatback thermal electric unit harness connector.

SEATBACK THERMAL ELECTRIC UNIT SENSOR

< DTC/CIRCUIT DIAGNOSIS >

Climate controlled seat control unit		Seatback thermal electric unit		Continuity
Connector	Terminal	Connector	Terminal	
Driver side	B530	67	B532	Existed
Passenger side	B560		B562	

4. Check continuity between climate controlled seat control unit harness connector and ground.

Climate controlled seat control unit		Ground	Continuity
Connector	Terminal		
Driver side	B530	67	Not existed
Passenger side	B560		

Is the inspection result normal?

YES >> GO TO 4.

NO >> Repair or replace harness.

4.CHECK SEATBACK THERMAL ELECTRIC UNIT SENSOR

Check seatback thermal electric unit sensor.

Refer to [SE-68. "Component Inspection"](#).

Is the inspection result normal?

YES >> GO TO 5.

NO >> Replace seatback thermal electric unit.

5.CHECK INTERMITTENT INCIDENT

Refer to [GI-38. "Intermittent Incident"](#).

>> INSPECTION END

Component Inspection

INFOID:000000006007972

1.CHECK SEATBACK THERMAL ELECTRIC UNIT SENSOR

1. Turn ignition switch OFF.
2. Disconnect seatback thermal electric unit connector.
3. Check resistance between seatback thermal electric unit terminals.

Seatback thermal electric unit		Resistance (KΩ) (Approx.)
Terminal		
67	68	1*

* : When sensor temperature is 25°C (77°F).

Is the inspection result normal?

YES >> INSPECTION END

NO >> Replace seatback thermal electric unit.

SEAT CUSHION THERMAL ELECTRIC UNIT

< DTC/CIRCUIT DIAGNOSIS >

SEAT CUSHION THERMAL ELECTRIC UNIT

Component Function Check

INFOID:000000006007973

1. CHECK SEAT CUSHION THERMAL ELECTRIC UNIT FUNCTION

Check whether or not the temperature of the seat cushion thermal electric unit changes in accordance with the HEAT or COOL switch operation of the climate controlled seat control switch.

Is the inspection result normal?

- YES >> INSPECTION END
 NO >> Refer to [SE-65. "Diagnosis Procedure"](#).

Diagnosis Procedure

INFOID:000000006007974

1. CHECK SEAT CUSHION THERMAL ELECTRIC UNIT INPUT SIGNAL

- Turn ignition switch ON.
- Check voltage between seat cushion thermal electric unit harness connector and ground.

(+)			(-)	Condition	Voltage (V) (Approx.)	
Seat cushion thermal electric unit						
Connector	Terminal					
Driver side	B533	61	Ground	Climate controlled seat switch	HEAT or COOL	0 - 12*
					Other than the above	0
		62			HEAT or COOL	0 - 12*
					Other than the above	0
Passenger side	B563	61		Climate controlled seat switch	HEAT or COOL	0 - 12*
					Other than the above	0
		62			HEAT or COOL	0 - 12*
					Other than the above	0

* : It value changes between 12 V and 0 V

NOTE:

Wait 1 minute or more after the activation start, and then start the measurement.

Is the inspection result normal?

- YES >> Replace seat cushion thermal electric unit.
 NO >> GO TO 2.

2. CHECK SEAT CUSHION THERMAL ELECTRIC UNIT CIRCUIT

- Turn ignition switch OFF.
- Disconnect climate controlled seat control unit connector and seat cushion thermal electric unit connector.
- Check continuity between climate controlled seat control unit harness connector and seat cushion thermal electric unit harness connector.

Climate controlled seat control unit			Seat cushion thermal electric unit		Continuity
Connector	Terminal	Connector	Terminal		
Driver side	B528	B533	61	61	Existed
			62	62	
Passenger side	B558	B563	61	61	
			62	62	

- Check continuity between climate controlled seat control unit harness connector and ground.

SEAT CUSHION THRMAL ELECTRIC UNIT

< DTC/CIRCUIT DIAGNOSIS >

Climate controlled seat control unit			Ground	Continuity
Connector		Terminal		
Driver side	B528	61		Not existed
		62		
Passenger side	B558	61		
		62		

Is the inspection result normal?

YES >> Replace climate controlled seat control unit.

NO >> Repair or replace harness.

SEAT CUSHION THERMAL ELECTRIC UNIT SENSOR

< DTC/CIRCUIT DIAGNOSIS >

SEAT CUSHION THERMAL ELECTRIC UNIT SENSOR

Component Function Check

INFOID:000000006062299

1. CHECK SEAT CUSHION THERMAL ELECTRIC UNIT SENSOR FUNCTION

Check whether or not the temperature of the seat cushion thermal electric unit changes in accordance with the HEAT or COOL switch operation of the climate controlled seat control switch.

Is the inspection result normal?

- YES >> INSPECTION END
 NO >> Refer to [SE-72. "Component Inspection"](#).

Diagnosis Procedure

INFOID:000000006069096

1. CHECK SEAT CUSHION THERMAL ELECTRIC UNIT SENSOR SIGNAL

- Turn ignition switch ON.
- Check voltage between seat cushion thermal electric unit harness connector and ground.

(+)		Terminal	(-)	Condition	Voltage (V) (Approx.)
Seat cushion thermal electric unit					
Connector					
Driver side	B533	70	Ground	Climate controlled seat operated	1 - 5
Passenger side	B563				

Is the inspection result normal?

- YES >> GO TO 3.
 NO >> GO TO 2.

2. CHECK SEAT CUSHION THERMAL ELECTRIC UNIT SENSOR CIRCUIT

- Turn ignition switch OFF.
- Disconnect climate controlled seat control unit connector and seat cushion thermal electric unit connector.
- Check continuity between climate controlled seat control unit harness connector and seat cushion thermal electric unit harness connector.

Climate controlled seat control unit		Terminal	Seat cushion thermal electric unit		Continuity
Connector			Connector	Terminal	
Driver side	B530	70	B533	70	Existed
Passenger side	B560		B563		

- Check continuity between climate controlled seat control unit harness connector and ground.

Climate controlled seat control unit		Terminal	Ground	Continuity
Connector				
Driver side	B530	70		Not existed
Passenger side	B560			

Is the inspection result normal?

- YES >> Replace climate controlled seat control unit.
 NO >> Repair or replace harness.

3. CHECK SEAT CUSHION THERMAL ELECTRIC UNIT SENSOR GROUND CIRCUIT

- Turn ignition switch OFF.
- Disconnect climate controlled seat control unit connector and seat cushion thermal electric unit connector.
- Check continuity between climate controlled seat control unit harness connector and seat cushion thermal electric unit harness connector.

SEAT CUSHION THERMAL ELECTRIC UNIT SENSOR

< DTC/CIRCUIT DIAGNOSIS >

Climate controlled seat control unit		Seat cushion thermal electric unit		Continuity
Connector	Terminal	Connector	Terminal	
Driver side	B530	69	B533	Existed
Passenger side	B560		B563	

4. Check continuity between climate controlled seat control unit harness connector and ground.

Climate controlled seat control unit		Ground	Continuity
Connector	Terminal		
Driver side	B530	69	Not existed
Passenger side	B560		

Is the inspection result normal?

YES >> GO TO 4.

NO >> Repair or replace harness.

4.CHECK SEAT CUSHION THERMAL ELECTRIC UNIT SENSOR

Check seat cushion thermal electric unit sensor.

Refer to [SE-72. "Component Inspection"](#).

Is the inspection result normal?

YES >> GO TO 5.

NO >> Replace seat cushion thermal electric unit.

5.CHECK INTERMITTENT INCIDENT

Refer to [GI-38. "Intermittent Incident"](#).

>> INSPECTION END

Component Inspection

INFOID:000000006007975

1.CHECK SEAT CUSHION THERMAL ELECTRIC UNIT SENSOR

1. Turn ignition switch OFF.
2. Disconnect seat cushion thermal electric unit connector.
3. Check resistance between seat cushion thermal electric unit terminals.

Seat cushion thermal electric unit		Resistance (KΩ) (Approx.)
Terminal		
69	70	1*

* : When sensor temperature is 25°C (77°F).

Is the inspection result normal?

YES >> INSPECTION END

NO >> Replace seat cushion thermal electric unit.

CLIMATE CONTROLLED SEAT CUSHION BLOWER MOTOR

< DTC/CIRCUIT DIAGNOSIS >

CLIMATE CONTROLLED SEAT CUSHION BLOWER MOTOR

Component Function Check

INFOID:000000006007980

1. CHECK CLIMATE CONTROLLED SEAT CUSHION BLOWER MOTOR FUNCTION

When turning the climate controlled seat switch to the HEAT or COOL mode position, check that the climate controlled seat cushion blower is operated in each specific mode.

Is the inspection result normal?

- YES >> INSPECTION END
 NO >> Refer to [SE-73. "Diagnosis Procedure"](#).

Diagnosis Procedure

INFOID:000000006007981

1. CHECK CLIMATE CONTROLLED SEAT CUSHION BLOWER MOTOR POWER SUPPLY

- Turn ignition switch ON.
- Check voltage between climate controlled seat cushion blower motor harness connector and ground.

(+)		Terminal	(-)	Condition	Voltage (V) (Approx.)	
Climate controlled seat cushion blower motor						
Connector						
Driver side	B531	64	Ground	Climate controlled seat switch	HEAT mode	12
					COOL mode	
					Other than the above	
Passenger side	B561			Climate controlled seat switch	HEAT mode	12
					COOL mode	
					Other than the above	

Is the inspection result normal?

- YES >> GO TO 3.
 NO >> GO TO 2.

2. CHECK CLIMATE CONTROLLED SEAT CUSHION BLOWER MOTOR POWER SUPPLY CIRCUIT

- Turn ignition switch OFF.
- Disconnect climate controlled seat cushion blower motor connector and climate controlled seat control unit connector.
- Check continuity between climate controlled seat cushion blower motor harness connector and climate controlled seat control unit harness connector.

Climate controlled seat cushion blower motor		Climate controlled seat control unit		Continuity
Connector	Terminal	Connector	Terminal	
Driver side	B531	B530	64	Existed
Passenger side	B561			

- Check continuity between climate controlled seat cushion blower motor harness connector and ground.

Climate controlled seat cushion blower motor		Terminal	Ground	Continuity
Connector				
Driver side	B531	64		Not existed
Passenger side	B561			

Is the inspection result normal?

- YES >> Replace climate controlled seat control unit.
 NO >> Repair or replace harness.

3. CHECK CLIMATE CONTROLLED SEAT CUSHION BLOWER MOTOR SPEED CONTROL SIGNAL

CLIMATE CONTROLLED SEAT CUSHION BLOWER MOTOR

< DTC/CIRCUIT DIAGNOSIS >

Check voltage between climate controlled seat cushion blower motor harness connector and ground.

(+)		(-)	Condition	Voltage (V) (Approx.)		
Climate controlled seat cushion blower motor						
Connector	Terminal	66	Ground	Climate controlled seat switch		
Driver side	B531				66	Ground
		COOL	HI	10		
			MID	8		
			LO	6		
Other than the above				0		
Passenger side	B561	66	Ground	HEAT	6.5 - 8	
				COOL	HI	10
					MID	8
					LO	6
Other than the above				0		

Is the inspection result normal?

YES >> GO TO 5.

NO >> GO TO 4.

4. CHECK CLIMATE CONTROLLED SEAT CUSHION BLOWER MOTOR SPEED CONTROL SIGNAL CIRCUIT

1. Turn ignition switch OFF.
2. Disconnect climate controlled seat cushion blower motor connector and climate controlled seat control unit connector.
3. Check continuity between climate controlled seat cushion blower motor harness connector and climate controlled seat control unit harness connector.

Climate controlled seat cushion blower motor		Climate controlled seat control unit		Continuity
Connector	Terminal	Connector	Terminal	
Driver side	B531	B530	66	Existed
Passenger side	B561	B560		

4. Check continuity between climate controlled seat cushion blower motor harness connector and ground.

Climate controlled seat cushion blower motor		Ground	Continuity
Connector	Terminal		
Driver side	B531	66	Not existed
Passenger side	B561		

Is the inspection result normal?

YES >> Replace climate controlled seat control unit.

NO >> Repair or replace harness.

5. CHECK CLIMATE CONTROLLED SEAT CUSHION BLOWER MOTOR GROUND CIRCUIT

1. Turn ignition switch OFF.
2. Disconnect climate controlled seat cushion blower motor and climate controlled seat control unit connector.
3. Check continuity between climate controlled seat cushion blower motor harness connector and climate controlled seat control unit harness connector.

CLIMATE CONTROLLED SEAT CUSHION BLOWER MOTOR

< DTC/CIRCUIT DIAGNOSIS >

Climate controlled seat cushion blower motor		Climate controlled seat control unit		Continuity	
Connector		Terminal	Connector		Terminal
Driver side	B531	65	B530	65	Existed
Passenger side	B561		B560		

4. Check continuity between climate controlled seat cushion blower motor harness connector and ground.

Climate controlled seat cushion blower motor		Terminal	Ground	Continuity
Connector				Continuity
Driver side	B531	65	Ground	Not existed
Passenger side	B561			

Is the inspection result normal?

YES >> Replace climate controlled seat cushion blower motor.

NO >> Repair or replace harness.

A
B
C
D
E
F
G
H
I
K
L
M
N
O
P

SE

CLIMATE CONTROLLED SEAT SWITCH INDICATOR

< DTC/CIRCUIT DIAGNOSIS >

CLIMATE CONTROLLED SEAT SWITCH INDICATOR

Component Function Check

INFOID:000000006007982

1. CHECK CLIMATE CONTROLLED SEAT SWITCH INDICATOR FUNCTION

Check that the related indicator lamp illuminates when climate controlled seat switch is set to HEAT or COOL mode.

Is the inspection result normal?

YES >> INSPECTION END

NO >> Refer to [SE-76. "Diagnosis Procedure"](#).

Diagnosis Procedure

INFOID:000000006007983

1. CHECK CLIMATE CONTROLLED SEAT SWITCH INPUT SIGNAL

1. Turn ignition switch ON.
2. Check voltage between climate controlled seat switch harness connector and ground.

(+)		(-)	Condition	Voltage (V) (Approx.)	
Climate controlled seat switch					
Connector	Terminal				
Driver side	M204	Ground	Climate controlled seat switch (driver side)	COOL mode	12
			Other than the above	0	
	5		HEAT mode	12	
			Other than the above	0	
Passenger side	M205	Ground	Climate controlled seat switch (passenger side)	COOL mode	12
			Other than the above	0	
	5		HEAT mode	12	
			Other than the above	0	

Is the inspection result normal?

YES >> GO TO 3.

NO >> GO TO 2.

2. CHECK CLIMATE CONTROLLED SEAT SWITCH INDICATOR CIRCUIT

1. Turn ignition switch OFF.
2. Disconnect climate controlled seat control unit connector and climate controlled seat switch connector.
3. Check continuity between climate controlled seat control unit harness connector and climate controlled seat switch harness connector.

Climate controlled seat switch		Climate controlled seat control unit		Continuity
Connector	Terminal	Connector	Terminal	
Driver side	M204	B530	4	53
			5	57
Passenger side	M205	B560	4	53
			5	57

4. Check continuity between climate controlled seat switch harness connector and ground.

CLIMATE CONTROLLED SEAT SWITCH INDICATOR

< DTC/CIRCUIT DIAGNOSIS >

Climate controlled seat switch		Terminal	Ground	Continuity
Connector				Continuity
Driver side	M204	4	Ground	Not existed
		5		
Passenger side	M205	4		
		5		

Is the inspection result normal?

YES >> Replace climate controlled seat control unit.

NO >> Repair or replace harness.

3.CHECK CLIMATE CONTROLLED SEAT SWITCH GROUND CIRCUIT

1. Turn ignition switch OFF.
2. Disconnect climate controlled seat switch connector.
3. Check continuity between climate controlled seat switch harness connector and ground.

Climate controlled seat switch		Terminal	Ground	Continuity
Connector				Continuity
Driver side	M204	6	Ground	Existed
Passenger side	M205			

Is the inspection result normal?

YES >> Replace climate controlled seat switch.

NO >> Repair or replace harness.

SE

CLIMATE CONTROLLED SEAT BLOWER FILTER

< DTC/CIRCUIT DIAGNOSIS >

CLIMATE CONTROLLED SEAT BLOWER FILTER

Diagnosis Procedure

INFOID:000000006007985

1. CHECK CLIMATE CONTROLLED SEAT CUSHION BLOWER FILTER

Remove climate controlled seat cushion blower filter and check that there is no clogging by dirt or foreign matters.

Is the inspection result normal?

YES >> INSPECTION END

NO >> Replace climate controlled seat cushion blower filter.

HEATED SEAT SWITCH

< DTC/CIRCUIT DIAGNOSIS >

HEATED SEAT SWITCH

Component Function Check

INFOID:000000005986838

1.CHECK HEATED SEAT SWITCH FUNCTION

Check that heated seat warms to preset temperature when operating heated seat switch to the optimal position.

Is the inspection result normal?

- YES >> INSPECTION END
 NO >> Refer to [SE-79. "Diagnosis Procedure"](#).

Diagnosis Procedure

INFOID:000000005986839

1.CHECK SEAT CUSHION HEATER INPUT SIGNAL

- Turn ignition switch OFF.
- Disconnect seat cushion heater connector.
- Turn ignition switch ON.
- Check voltage between seat cushion heater harness connector and ground.

(+)			(-)	Condition	Voltage (V) (Approx.)	
Seat cushion heater						
Connector		Terminal				
Driver side	B534	72	Ground	Heated seat switch (driver side)	OFF	0
				1 (Min. temperature)	10.66*	
				2	11.18*	
				3	11.76*	
				4	12.12*	
				5	12.47*	
Passenger side	B574	72		Heated seat switch (passenger side)	OFF	0
				1 (Min. temperature)	10.66*	
				2	11.18*	
				3	11.76*	
				4	12.12*	
				5	12.47*	
			6 (Max. temperature)	12.83*		

*: When thermistor temperature is 20°C (68°F).

Is the inspection result normal?

- YES >> INSPECTION END
 NO >> GO TO 2.

2.CHECK HEATED SEAT SWITCH CIRCUIT

- Turn ignition switch OFF.
- Disconnect heated seat switch connector.
- Check continuity between heated seat switch harness connector and seat cushion heater harness connector.

HEATED SEAT SWITCH

< DTC/CIRCUIT DIAGNOSIS >

Heated seat switch		Seat cushion heater		Continuity
Connector	Terminal	Connector	Terminal	
Driver side	M198	B534	72	Existed
Passenger side	M199			

4. Check continuity between heated seat switch harness connector and ground.

Heated seat switch		Ground	Continuity
Connector	Terminal		
Driver side	M198	2	Not existed
Passenger side	M199		

Is the inspection result normal?

- YES >> GO TO 3.
- NO >> Repair or replace harness.

3.CHECK HEATED SEAT SWITCH

Check heated seat switch.
Refer to [SE-80. "Component Inspection"](#).

Is the inspection result normal?

- YES >> GO TO 4.
- NO >> Replace heated seat switch.

4.CHECK INTERMITTENT INCIDENT

Check intermittent incident.
Refer to [GI-38. "Intermittent Incident"](#).

>> INSPECTION END

Component Inspection

INFOID:000000005986840

1.CHECK FRONT HEATED SEAT SWITCH

1. Turn ignition OFF.
2. Disconnect heated seat switch connector.
3. Check resistance between heated seat switch terminals under the following conditions.

Heated seat switch		Condition	Resistance (KΩ) (Approx.)
Terminal			
5	1	ON	0
		OFF	∞
	2	OFF	∞
		1 (Min. temperature)	2.400
		2	1.800
		3	1.200
		4	0.910
		5	0.620
6 (Max. temperature)	0.348		

Is the inspection result normal?

- YES >> INSPECTION END
- NO >> Replace heated seat switch.

HEATED SEAT RELAY

< DTC/CIRCUIT DIAGNOSIS >

HEATED SEAT RELAY

Component Function Check

INFOID:000000005986846

1. CHECK HEATED SEAT RELAY FUNCTION

Check that heated seat warms to preset temperature when operating heated seat switch to the optimal position.

Is the inspection result normal?

- YES >> INSPECTION END
NO >> Refer to [SE-81. "Diagnosis Procedure"](#)

Diagnosis Procedure

INFOID:000000005986847

1. CHECK HEATED SEAT RELAY POWER SUPPLY

1. Turn ignition switch OFF.
2. Disconnect heated seat relay.
3. Turn ignition switch ON.
4. Check voltage between heated seat relay terminal connector and ground.

(+)		(-)	Voltage (V) (Approx.)
Heated seat relay			
Connector	Terminal		
M70	2	Ground	Battery voltage

Is the inspection result normal?

- YES >> GO TO 3.
NO >> GO TO 2.

2. CHECK HEATED SEAT RELAY POWER SUPPLY CIRCUIT

1. Turn ignition switch OFF.
2. Disconnect fuse block (J/B) connector.
3. Check continuity between heated seat relay terminal connector and fuse block (J/B) harness connector.

Heated seat relay		Fuse block (J/B)		Continuity
Connector	Terminal	Connector	Terminal	
M70	2	M1	2A	Existed

4. Check continuity between heated seat relay terminal connector and ground.

Heated seat relay		Ground	Continuity
Connector	Terminal		
M70	2		Not existed

Is the inspection result normal?

- YES >> GO TO 5.
NO >> Repair or replace harness.

3. CHECK HEATED SEAT RELAY GROUND CIRCUIT

1. Turn ignition switch OFF.
2. Check continuity between heated seat relay terminal connector and ground.

Heated seat relay		Ground	Continuity
Connector	Terminal		
M70	1		Existed

Is the inspection result normal?

- YES >> GO TO 4.

HEATED SEAT RELAY

< DTC/CIRCUIT DIAGNOSIS >

NO >> Repair or replace harness.

4.CHECK HEATED SEAT RELAY

Check heated seat relay.

Refer to [SE-82, "Component Inspection"](#).

Is the inspection result normal?

YES >> GO TO 5.

NO >> Replace heated seat relay.

5.CHECK INTERMITTENT INCIDENT

Check intermittent incident.

Refer to [GI-38, "Intermittent Incident"](#).

>> INSPECTION END

Component Inspection

INFOID:000000005986848

1.CHECK HEATED SEAT RELAY

1. Turn ignition switch OFF.
2. Disconnect heated seat relay.
3. Check continuity between heated seat relay terminals.

Terminal		Condition	Continuity
3	5	12 V direct current supply between terminals 1 and 2.	Existed
		No current supply	Not existed

Is the inspection result normal?

YES >> INSPECTION END

NO >> Replace heated seat relay.

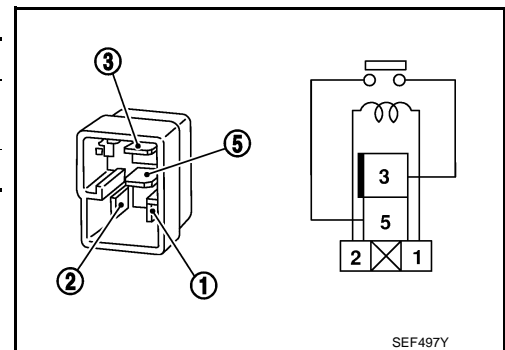

SEATBACK HEATER

< DTC/CIRCUIT DIAGNOSIS >

SEATBACK HEATER

Component Function Check

INFOID:000000005986866

1.CHECK SEATBACK HEATER FUNCTION

Check that heated seat warms to preset temperature when operating heated seat switch to the optimal position.

Is the inspection result normal?

- YES >> INSPECTION END
- NO >> Refer to [SE-83. "Component Inspection"](#).

Diagnosis Procedure

INFOID:000000006099205

1.CHECK SEATBACK HEATER SIGNAL CIRCUIT

1. Turn ignition switch OFF.
2. Disconnect seat cushion heater connector and seatback heater connector.
3. Check continuity between seat cushion heater harness connector and seatback heater harness connector.

Seat cushion heater		Seatback heater		Continuity
Connector	Terminal	Connector	Terminal	
Driver side	B534	B535	78	Existed
Passenger side	B574	B575		

4. Check continuity seat cushion heater harness connector and ground.

Seat cushion heater		Ground	Continuity
Connector	Terminal		
Driver side	B534	78	Not existed
Passenger side	B574		

Is the inspection result normal?

- YES >> GO TO 2.
- NO >> Repair or replace harness.

2.CHECK SEATBACK HEATER

Check seatback heater.

Refer to [SE-83. "Component Inspection"](#).

Is the inspection result normal?

- YES >> Replace seat cushion heater.
- NO >> Replace seatback heater.

Component Inspection

INFOID:000000005986867

1.CHECK SEATBACK HEATER

1. Turn ignition switch OFF.
2. Disconnect seatback heater connector.
3. Check resistance between seatback heater terminals.

Seatback heater		Condition	Resistance (Ω) (Approx.)
Terminal			
77	78	When seatback heater temperature is 20°C (68°F)	5.39 - 6.57

NOTE:

Resistance value changes according to temperature.

Is the inspection result normal?

SEATBACK HEATER

< DTC/CIRCUIT DIAGNOSIS >

YES >> INSPECTION END
NO >> Replace seatback heater.

HEATED SEAT SWITCH INDICATOR

< DTC/CIRCUIT DIAGNOSIS >

HEATED SEAT SWITCH INDICATOR

Component Function Check

INFOID:000000005986872

1.CHECK HEATED SEAT SWITCH INDICATOR FUNCTION

Check that the related indicator lamp illuminates when heated seat switch is turned ON.

Is the inspection result normal?

YES >> INSPECTION END

NO >> Refer to [SE-85, "Diagnosis Procedure"](#).

Diagnosis Procedure

INFOID:000000005986873

1.CHECK HEATED SEAT SWITCH INDICATOR GROUND CIRCUIT

1. Turn ignition switch OFF.
2. Disconnect heated seat switch connector.
3. Check continuity between heated seat switch harness connector and ground.

Heated seat switch		Ground	Continuity
Connector	Terminal		
Driver side	M198	6	Existed
Passenger side	M199		

Is the inspection result normal?

YES >> Replace heated seat switch.

NO >> Repair or replace harness.

A
B
C
D
E
F
G
H
I
K
L
M
N
O
P

SE

CLIMATE CONTROLLED SEAT DOES NOT OPERATE.

< SYMPTOM DIAGNOSIS >

SYMPTOM DIAGNOSIS

CLIMATE CONTROLLED SEAT DOES NOT OPERATE.

Diagnosis Procedure

INFOID:000000006007986

1. CHECK CLIMATE CONTROLLED SEAT CONTROL UNIT POWER SUPPLY AND GROUND CIRCUIT

Check climate controlled seat control unit power supply and ground circuit.

Refer to [SE-53, "CLIMATE CONTROLLED SEAT CONTROL UNIT : Diagnosis Procedure"](#).

Is the inspection result normal?

YES >> GO TO 2.

NO >> Repair or replace the malfunctioning parts.

2. CHECK CLIMATE CONTROLLED SEAT SWITCH

Check climate controlled seat switch.

Refer to [SE-62, "Component Function Check"](#).

Is the inspection result normal?

YES >> GO TO 3.

NO >> Repair or replace the malfunctioning parts.

3. CHECK CLIMATE CONTROLLED SEAT CUSHION BLOWER MOTOR

Check climate controlled seat cushion blower motor.

Refer to [SE-73, "Component Function Check"](#).

Is the inspection result normal?

YES >> GO TO 4.

NO >> Repair or replace the malfunctioning parts.

4. REPLACE CLIMATE CONTROLLED SEAT CONTROL UNIT

Replace climate controlled seat control unit.

Is the inspection result normal?

YES >> INSPECTION END

NO >> GO TO 5.

5. CONFIRM THE OPERATION

Confirm the operation again.

Is the inspection result normal?

YES >> Check intermittent incident. Refer to [GI-38, "Intermittent Incident"](#).

NO >> GO TO 1.

TEMPERATURE ADJUSTMENT IS IMPOSSIBLE

< SYMPTOM DIAGNOSIS >

TEMPERATURE ADJUSTMENT IS IMPOSSIBLE

Description

INFOID:000000006007989

Blower fan motor noise is constant though performing temperature adjustment operation.

NOTE:

When turning climate controlled seat switch ON, blower fan motor may stay in the low speed operation for approximately 60 seconds. But this is not a malfunction.

Diagnosis Procedure

INFOID:000000006007990

Seat cushion

1. CHECK CLIMATE CONTROLLED SEAT CUSHION BLOWER FILTER

Check climate controlled seat cushion blower filter.

Refer to [SE-78. "Diagnosis Procedure"](#).

Is the inspection result normal?

YES >> GO TO 2.

NO >> Repair or replace the malfunctioning parts.

2. CHECK CLIMATE CONTROLLED SEAT SWITCH

Check climate controlled seat switch.

Refer to [SE-62. "Component Function Check"](#).

Is the inspection result normal?

YES >> GO TO 3.

NO >> Repair or replace the malfunctioning parts.

3. CHECK SEAT CUSHION THERMAL ELECTRIC UNIT SENSOR

Check seat cushion thermal electric unit sensor.

Refer to [SE-72. "Component Inspection"](#).

Is the inspection result normal?

YES >> GO TO 4.

NO >> Repair or replace the malfunctioning parts.

4. CHECK SEAT CUSHION THERMAL ELECTRIC UNIT

Check seat cushion thermal electric unit.

Refer to [SE-69. "Component Function Check"](#).

Is the inspection result normal?

YES >> GO TO 5.

NO >> Repair or replace the malfunctioning parts.

5. CHECK CLIMATE CONTROLLED SEAT CUSHION BLOWER MOTOR

Check climate controlled seat cushion blower motor.

Refer to [SE-73. "Component Function Check"](#).

Is the inspection result normal?

YES >> GO TO 6.

NO >> Repair or replace the malfunctioning parts.

6. CONFIRM THE OPERATION

Confirm the operation again.

Is the inspection result normal?

YES >> Check intermittent incident. Refer to [GI-38. "Intermittent Incident"](#).

NO >> GO TO 1.

Seatback

1. CHECK CLIMATE CONTROLLED SEAT CUSHION BLOWER FILTER

TEMPERATURE ADJUSTMENT IS IMPOSSIBLE

< SYMPTOM DIAGNOSIS >

Check climate controlled seat cushion blower filter.

Refer to [SE-78, "Diagnosis Procedure"](#).

Is the inspection result normal?

YES >> GO TO 2.

NO >> Repair or replace the malfunctioning parts.

2.CHECK CLIMATE CONTROLLED SEAT SWITCH

Check climate controlled seat switch.

Refer to [SE-62, "Component Function Check"](#).

Is the inspection result normal?

YES >> GO TO 3.

NO >> Repair or replace the malfunctioning parts.

3.CHECK SEATBACK THERMAL ELECTRIC UNIT SENSOR

Check seatback thermal electric unit sensor.

Refer to [SE-68, "Component Inspection"](#).

Is the inspection result normal?

YES >> GO TO 4.

NO >> Repair or replace the malfunctioning parts.

4.CHECK SEATBACK THERMAL ELECTRIC UNIT

Check seatback thermal electric unit.

Refer to [SE-65, "Component Function Check"](#).

Is the inspection result normal?

YES >> GO TO 5.

NO >> Repair or replace the malfunctioning parts.

5.CHECK CLIMATE CONTROLLED SEAT CUSHION BLOWER MOTOR

Check climate controlled seat cushion blower motor.

Refer to [SE-73, "Component Function Check"](#).

Is the inspection result normal?

YES >> GO TO 6.

NO >> Repair or replace the malfunctioning parts.

6.CONFIRM THE OPERATION

Confirm the operation again.

Is the inspection result normal?

YES >> Check intermittent incident. Refer to [GI-38, "Intermittent Incident"](#).

NO >> GO TO 1.

CLIMATE CONTROLLED SEAT ACTIVATES ONCE BUT STOPS IMMEDIATELY

< SYMPTOM DIAGNOSIS >

CLIMATE CONTROLLED SEAT ACTIVATES ONCE BUT STOPS IMMEDIATELY

Description

INFOID:000000006007993

When turning climate controlled seat switch ON (COOL or HEAT), climate controlled seat activates once but stops immediately. (Repeats the same operation when turning ignition switch OFF and turning ignition switch ON again.)

Diagnosis Procedure

INFOID:000000006007994

1.CHECK FAIL-SAFE

Check fail-safe detecting conditions and repair cause of fail-safe status.

Refer to [SE-18. "Fail-safe"](#).

Is the inspection result normal?

YES >> GO TO 2.

NO >> Repair or replace the malfunctioning parts.

2.CHECK TEMPERATURE ADJUSTMENT FUNCTION

Check temperature adjustment function of climate controlled seat.

Refer to [SE-87. "Diagnosis Procedure"](#).

Is the inspection result normal?

YES >> GO TO 3.

NO >> Repair or replace the malfunctioning parts.

3.CONFIRM THE OPERATION

Confirm the operation again.

Is the inspection result normal?

YES >> Check intermittent incident. Refer to [GI-38. "Intermittent Incident"](#).

NO >> GO TO 1.

A
B
C
D
E
F
G
H
I
K
L
M
N
O
P

SE

SEAT SWITCH INDICATOR IS NOT ILLUMINATED IN HEAT OR COOL POSITION

< SYMPTOM DIAGNOSIS >

SEAT SWITCH INDICATOR IS NOT ILLUMINATED IN HEAT OR COOL POSITION

Diagnosis Procedure

INFOID:000000006007995

1. CHECK CLIMATE CONTROLLED SEAT SWITCH INDICATOR

Check climate controlled seat switch indicator.
Refer to [SE-76, "Component Function Check"](#).

Is the inspection result normal?

- YES >> GO TO 2.
- NO >> Repair or replace the malfunctioning parts.

2. CONFIRM THE OPERATION

Confirm the operation again.

Is the inspection result normal?

- YES >> Check intermittent incident. Refer to [GI-38, "Intermittent Incident"](#).
- NO >> GO TO 1.

HEATED SEAT DOES NOT OPERATE

< SYMPTOM DIAGNOSIS >

HEATED SEAT DOES NOT OPERATE

Diagnosis Procedure

INFOID:000000005986879

1. CHECK HEATED SEAT SWITCH POWER SUPPLY

Check heated seat switch power supply.

Refer to [SE-60, "HEATED SEAT SWITCH : Diagnosis Procedure"](#).

Is the inspection result normal?

YES >> GO TO 2.

NO >> Repair or replace the malfunctioning parts.

2. CHECK HEATED SEAT RELAY

Check heated seat relay.

Refer to [SE-81, "Component Function Check"](#).

Is the inspection result normal?

YES >> GO TO 3.

NO >> Repair or replace the malfunctioning parts.

3. CHECK SEAT CUSHION HEATER POWER SUPPLY AND GROUND CIRCUIT

Check seat cushion heater power supply and ground circuit.

Refer to [SE-57, "SEAT CUSHION HEATER : Diagnosis Procedure"](#).

Is the inspection result normal?

YES >> GO TO 4.

NO >> Repair or replace the malfunctioning parts.

4. CHECK HEATED SEAT SWITCH

Check heated seat switch.

Refer to [SE-79, "Component Function Check"](#).

Is the inspection result normal?

YES >> GO TO 5.

NO >> Repair or replace the malfunctioning parts.

5. CONFIRM THE OPERATION

Confirm the operation again.

Is the inspection result normal?

YES >> Check intermittent incident. Refer to [GI-38, "Intermittent Incident"](#).

NO >> GO TO 1.

A
B
C
D
E
F
G
H
I
SE
K
L
M
N
O
P

SEATBACK HEATER ONLY DOES NOT OPERATE

< SYMPTOM DIAGNOSIS >

SEATBACK HEATER ONLY DOES NOT OPERATE

Diagnosis Procedure

INFOID:000000005986882

1. CHECK SEATBACK HEATER

Check seatback heater.

Refer to [SE-83, "Component Function Check"](#).

Is the inspection result normal?

YES >> GO TO 2.

NO >> Repair or replace the malfunctioning parts.

2. CONFIRM THE OPERATION

Confirm the operation again.

Is the inspection result normal?

YES >> Check intermittent incident. Refer to [GI-38, "Intermittent Incident"](#).

NO >> GO TO 1.

CANNOT ADJUST HEATED SEAT TEMPERATURE

< SYMPTOM DIAGNOSIS >

CANNOT ADJUST HEATED SEAT TEMPERATURE

Diagnosis Procedure

INFOID:000000005986884

1.CHECK HEATED SEAT SWITCH

Check heated seat switch.

Refer to [SE-79, "Component Function Check"](#).

Is the inspection result normal?

YES >> GO TO 2.

NO >> Repair or replace the malfunctioning parts.

2.CONFIRM THE OPERATION

Confirm the operation again.

Is the inspection result normal?

YES >> Check intermittent incident. Refer to [GI-38, "Intermittent Incident"](#).

NO >> Replace seat cushion heater.

A
B
C
D
E
F
G
H
I
K
L
M
N
O
P

SE

HEATED SEAT SWITCH INDICATOR DOES NOT TURN ON

< SYMPTOM DIAGNOSIS >

HEATED SEAT SWITCH INDICATOR DOES NOT TURN ON

Diagnosis Procedure

INFOID:000000005986886

1. CHECK HEATED SEAT SWITCH INDICATOR

Check heated seat switch indicator.

Refer to [SE-85, "Component Function Check"](#).

Is the inspection result normal?

YES >> GO TO 2.

NO >> Repair or replace the malfunctioning parts.

2. CONFIRM THE OPERATION

Confirm the operation again.

Is the inspection result normal?

YES >> Check intermittent incident. Refer to [GI-38, "Intermittent Incident"](#).

NO >> GO TO 1.

SQUEAK AND RATTLE TROUBLE DIAGNOSES

< SYMPTOM DIAGNOSIS >

SQUEAK AND RATTLE TROUBLE DIAGNOSES

Work Flow

INFOID:000000006114046

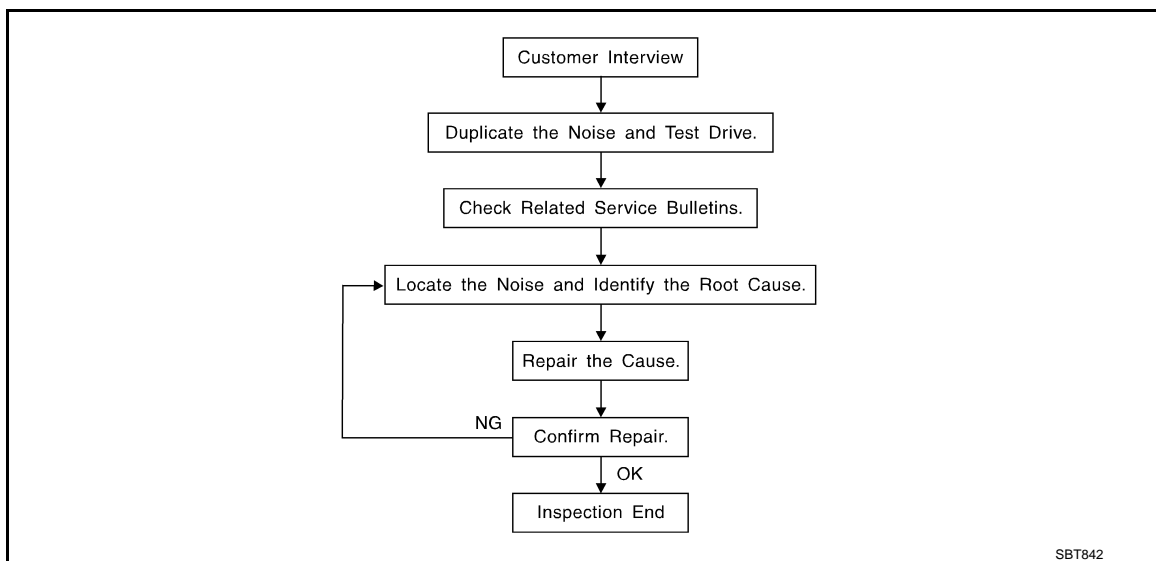

CUSTOMER INTERVIEW

Interview the customer if possible, to determine the conditions that exist when the noise occurs. Use the Diagnostic Worksheet during the interview to document the facts and conditions when the noise occurs and any of customer's comments; refer to [SE-99, "Diagnostic Worksheet"](#). This information is necessary to duplicate the conditions that exist when the noise occurs.

- The customer may not be able to provide a detailed description or the location of the noise. Attempt to obtain all the facts and conditions that exist when the noise occurs (or does not occur).
- If there is more than one noise in the vehicle, perform a diagnosis and repair the noise that the customer is concerned about. This can be accomplished by performing a cruise test on the vehicle with the customer.
- After identifying the type of noise, isolate the noise in terms of its characteristics. The noise characteristics are provided so the customer, service adviser and technician are all speaking the same language when defining the noise.
- Squeak – (Like tennis shoes on a clean floor)
Squeak characteristics include the light contact/fast movement/brought on by road conditions/hard surfaces = higher pitch noise/softer surfaces = lower pitch noises/edge to surface = chirping
- Creak – (Like walking on an old wooden floor)
Creak characteristics include firm contact/slow movement/twisting with a rotational movement/pitch dependent on materials/often brought on by activity.
- Rattle – (Like shaking a baby rattle)
Rattle characteristics include the fast repeated contact/vibration or similar movement/loose parts/missing clip or fastener/incorrect clearance.
- Knock – (Like a knock on a door)
Knock characteristics include hollow sounding/sometimes repeating/often brought on by driver action.
- Tick – (Like a clock second hand)
Tick characteristics include gentle contacting of light materials/loose components/can be caused by driver action or road conditions.
- Thump – (Heavy, muffled knock noise)
Thump characteristics include softer knock/dead sound often brought on by activity.
- Buzz – (Like a bumblebee)
Buzz characteristics include high frequency rattle/firm contact.
- Often the degree of acceptable noise level will vary depending up on the person. A noise that a technician may judge as acceptable may be very irritating to the customer.
- Weather conditions, especially humidity and temperature, may have a great effect on noise level.

DUPLICATE THE NOISE AND TEST DRIVE

If possible, drive the vehicle with the customer until the noise is duplicated. Note any additional information on the Diagnostic Worksheet regarding the conditions or location of the noise. This information can be used to duplicate the same conditions when the repair is reconfirmed.

SQUEAK AND RATTLE TROUBLE DIAGNOSES

< SYMPTOM DIAGNOSIS >

If the noise can be duplicated easily during the test drive, to help identify the source of the noise, try to duplicate the noise with the vehicle stopped by doing one or all of the following:

- 1) Close a door.
 - 2) Tap or push/pull around the area where the noise appears to be coming from.
 - 3) Rev the engine.
 - 4) Use a floor jack to recreate vehicle "twist".
 - 5) At idle, apply engine load (electrical load, half-clutch on M/T models, drive position on A/T models).
 - 6) Raise the vehicle on a hoist and hit a tire with a rubber hammer.
- Drive the vehicle and attempt to duplicate the conditions the customer states exist when the noise occurs.
 - If it is difficult to duplicate the noise, drive the vehicle slowly on an undulating or rough road to stress the vehicle body.

CHECK RELATED SERVICE BULLETINS

After verifying the customer concern or symptom, check ASIST for Technical Service Bulletins (TSBs) related to that concern or symptom.

If a TSB relates to the symptom, follow the procedure to repair the noise.

LOCATE THE NOISE AND IDENTIFY THE ROOT CAUSE

1. Narrow down the noise to a general area. To help pinpoint the source of the noise, use a listening tool (Chassis ear: J-39570, Engine ear and mechanics stethoscope).
2. Narrow down the noise to a more specific area and identify the cause of the noise by:
 - Removing the components in the area that is are suspected to be the cause of the noise.
Do not use too much force when removing clips and fasteners, otherwise clips and fastener can be broken or lost during the repair, resulting in the creation of new noise.
 - Tapping or pushing/pulling the component that is are suspected to be the cause of the noise.
Do not tap or push/pull the component with excessive force, otherwise the noise will be eliminated only temporarily.
 - Feeling for a vibration by hand by touching the component(s) that is are suspected to be the cause of the noise.
 - Placing a piece of paper between components that are suspected to be the cause of the noise.
 - Looking for loose components and contact marks.
Refer to [SE-97, "Inspection Procedure"](#).

REPAIR THE CAUSE

- If the cause is a loose component, tighten the component securely.
- If the cause is insufficient clearance between components:
 - Separate components by repositioning or loosening and retightening the component, if possible.
 - Insulate components with a suitable insulator such as urethane pads, foam blocks, felt cloth tape or urethane tape. A Nissan Squeak and Rattle Kit (J-43980) is available through the authorized Nissan Parts Department.

CAUTION:

Never use excessive force as many components are constructed of plastic and may be damaged.

NOTE:

Always check with the Parts Department for the latest parts information.

The following materials are contained in the Nissan Squeak and Rattle Kit (J-43980). Each item can be ordered separately as needed.

URETHANE PADS [1.5 mm (0.059 in) thick]

Insulates connectors, harness, etc.

76268-9E005: 100 × 135 mm (3.94 × 5.31 in)/76884-71L01: 60 × 85 mm (2.36 × 3.35 in)/76884-71L02: 15 × 25 mm (0.59 × 0.98 in)

INSULATOR (Foam blocks)

Insulates components from contact. Can be used to fill space behind a panel.

73982-9E000: 45 mm (1.77 in) thick, 50 × 50 mm (1.97 × 1.97 in)/73982-

50Y00: 10 mm (0.39 in) thick, 50 × 50 mm (1.97 × 1.97 in)

INSULATOR (Light foam block)

80845-71L00: 30 mm (1.18 in) thick, 30 × 50 mm (1.18 × 1.97in)

FELT CLOTHTAPE

Used to insulate where movement does not occur. Ideal for instrument panel applications.

68370-4B000: 15 × 25 mm (0.59 × 0.98 in) pad/68239-13E00: 5 mm (0.20 in) wide tape roll

The following materials, not found in the kit, can also be used to repair squeaks and rattles.

UHMW (TEFLON) TAPE

SQUEAK AND RATTLE TROUBLE DIAGNOSES

< SYMPTOM DIAGNOSIS >

Insulates where slight movement is present. Ideal for instrument panel applications.

SILICONE GREASE

Used in place of UHMW tape that is be visible or does not fit. Will only last a few months.

SILICONE SPRAY

Used when grease cannot be applied.

DUCT TAPE

Used to eliminate movement.

CONFIRM THE REPAIR

Confirm that the cause of a noise is repaired by test driving the vehicle. Operate the vehicle under the same conditions as when the noise originally occurred. Refer to the notes on the Diagnostic Worksheet.

Inspection Procedure

INFOID:000000006114047

Refer to Table of Contents for specific component removal and installation information.

INSTRUMENT PANEL

Most incidents are caused by contact and movement between:

1. The cluster lid A and instrument panel
2. Acrylic lens and combination meter housing
3. Instrument panel to front pillar garnish
4. Instrument panel to windshield
5. Instrument panel mounting pins
6. Wiring harnesses behind the combination meter
7. A/C defroster duct and duct joint

These incidents can usually be located by tapping or moving the components to duplicate the noise or by pressing on the components while driving to stop the noise. Most of these incidents can be repaired by applying felt cloth tape or silicon spray (in hard to reach areas). Urethane pads can be used to insulate wiring harness.

CAUTION:

Never use silicone spray to isolate a squeak or rattle. If the area is saturated with silicone, the recheck of repair becomes impossible.

CENTER CONSOLE

Components to pay attention to include:

1. Shifter assembly cover to finisher
2. A/C control unit and cluster lid C
3. Wiring harnesses behind audio and A/C control unit

The instrument panel repair and isolation procedures also apply to the center console.

DOORS

Pay attention to the following:

1. Finisher and inner panel making a slapping noise
2. Inside handle escutcheon to door finisher
3. Wiring harnesses tapping
4. Door striker out of alignment causing a popping noise on starts and stops

Tapping or moving the components or pressing on them while driving to duplicate the conditions can isolate many of these incidents. The areas can usually be insulated with felt cloth tape or insulator foam blocks from the Nissan Squeak and Rattle Kit (J-43980) to repair the noise.

TRUNK

Trunk noises are often caused by a loose jack or loose items put into the trunk by the customer.

In addition look for the following:

1. Trunk lid dumpers out of adjustment
2. Trunk lid striker out of adjustment
3. The trunk lid torsion bars knocking together
4. A loose license plate or bracket

SQUEAK AND RATTLE TROUBLE DIAGNOSES

< SYMPTOM DIAGNOSIS >

Most of these incidents can be repaired by adjusting, securing or insulating the item(s) or component(s) causing the noise.

SUNROOF/HEADLINING

Noises in the sunroof/headlining area can often be traced to one of the following:

1. Sunroof lid, rail, linkage or seals making a rattle or light knocking noise
2. Sunvisor shaft shaking in the holder
3. Front or rear windshield touching headlining and squeaking

Again, pressing on the components to stop the noise while duplicating the conditions can isolate most of these incidents. Repairs usually consist of insulating with felt cloth tape.

SEATS

When isolating seat noise it's important to note the position the seats in and the load placed on the seat when the noise occurs. These conditions should be duplicated when verifying and isolating the cause of the noise.

Cause of seat noise include:

1. Headrest rods and holder
2. A squeak between the seat pad cushion and frame
3. The rear seatback lock and bracket

These noises can be isolated by moving or pressing on the suspected components while duplicating the conditions under which the noise occurs. Most of these incidents can be repaired by repositioning the component or applying urethane tape to the contact area.

UNDERHOOD

Some interior noise may be caused by components under the hood or on the engine wall. The noise is then transmitted into the passenger compartment.

Causes of transmitted underhood noise include:

1. Any component mounted to the engine wall
2. Components that pass through the engine wall
3. Engine wall mounts and connectors
4. Loose radiator mounting pins
5. Hood bumpers out of adjustment
6. Hood striker out of adjustment

These noises can be difficult to isolate since they cannot be reached from the interior of the vehicle. The best method is to secure, move or insulate one component at a time and test drive the vehicle. Also, engine RPM or load can be changed to isolate the noise. Repairs can usually be made by moving, adjusting, securing, or insulating the component causing the noise.

SQUEAK AND RATTLE TROUBLE DIAGNOSES

< SYMPTOM DIAGNOSIS >

Diagnostic Worksheet

INFOID:000000006114048



SQUEAK & RATTLE DIAGNOSTIC WORKSHEET

Dear Infiniti Customer:

We are concerned about your satisfaction with your Infiniti vehicle. Repairing a squeak or rattle sometimes can be very difficult. To help us fix your Infiniti right the first time, please take a moment to note the area of the vehicle where the squeak or rattle occurs and under what conditions. You may be asked to take a test drive with a service consultant or technician to ensure we confirm the noise you are hearing.

I. WHERE DOES THE NOISE COME FROM? (circle the area of the vehicle)

The illustrations are for reference only, and may not reflect the actual configuration of your vehicle.

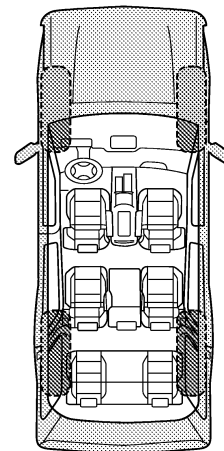
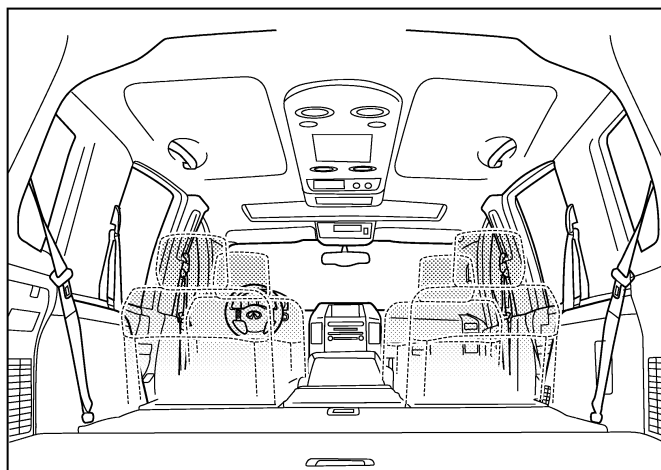
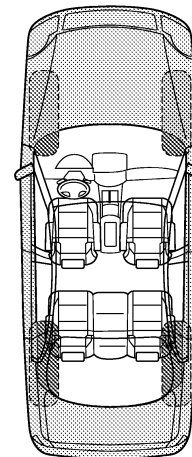
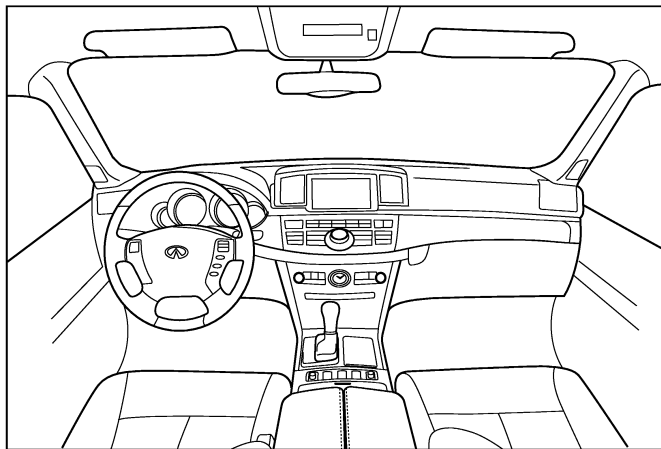

Continue to page 2 of the worksheet and briefly describe the location of the noise or rattle. In addition, please indicate the conditions which are present when the noise occurs.

PIIB8741E

A
B
C
D
E
F
G
H
I
SE
K
L
M
N
O
P

SQUEAK AND RATTLE TROUBLE DIAGNOSES

< SYMPTOM DIAGNOSIS >

SQUEAK & RATTLE DIAGNOSTIC WORKSHEET - page 2

Briefly describe the location where the noise occurs:

II. WHEN DOES IT OCCUR? (please check the boxes that apply)

- | | |
|---|--|
| <input type="checkbox"/> anytime | <input type="checkbox"/> after sitting out in the rain |
| <input type="checkbox"/> 1st time in the morning | <input type="checkbox"/> when it is raining or wet |
| <input type="checkbox"/> only when it is cold outside | <input type="checkbox"/> dry or dusty conditions |
| <input type="checkbox"/> only when it is hot outside | <input type="checkbox"/> other: |

III. WHEN DRIVING:

- through driveways
- over rough roads
- over speed bumps
- only about ____ mph
- on acceleration
- coming to a stop
- on turns: left, right or either (circle)
- with passengers or cargo
- other: _____
- after driving ____ miles or ____ minutes

IV. WHAT TYPE OF NOISE

- squeak (like tennis shoes on a clean floor)
- creak (like walking on an old wooden floor)
- rattle (like shaking a baby rattle)
- knock (like a knock at the door)
- tick (like a clock second hand)
- thump (heavy, muffled knock noise)
- buzz (like a bumble bee)

TO BE COMPLETED BY DEALERSHIP PERSONNEL

Test Drive Notes:

	YES	NO	Initials of person performing
Vehicle test driven with customer	<input type="checkbox"/>	<input type="checkbox"/>	_____
- Noise verified on test drive	<input type="checkbox"/>	<input type="checkbox"/>	_____
- Noise source located and repaired	<input type="checkbox"/>	<input type="checkbox"/>	_____
- Follow up test drive performed to confirm repair	<input type="checkbox"/>	<input type="checkbox"/>	_____

VIN: _____ Customer Name: _____
W.O.# _____ Date: _____

This form must be attached to Work Order

PIIB8742E

FRONT SEAT

< REMOVAL AND INSTALLATION >

REMOVAL AND INSTALLATION

FRONT SEAT

Exploded View

DRIVER SEAT WITH SEAT HEATER

INFOID:000000006046717

SEC. 870

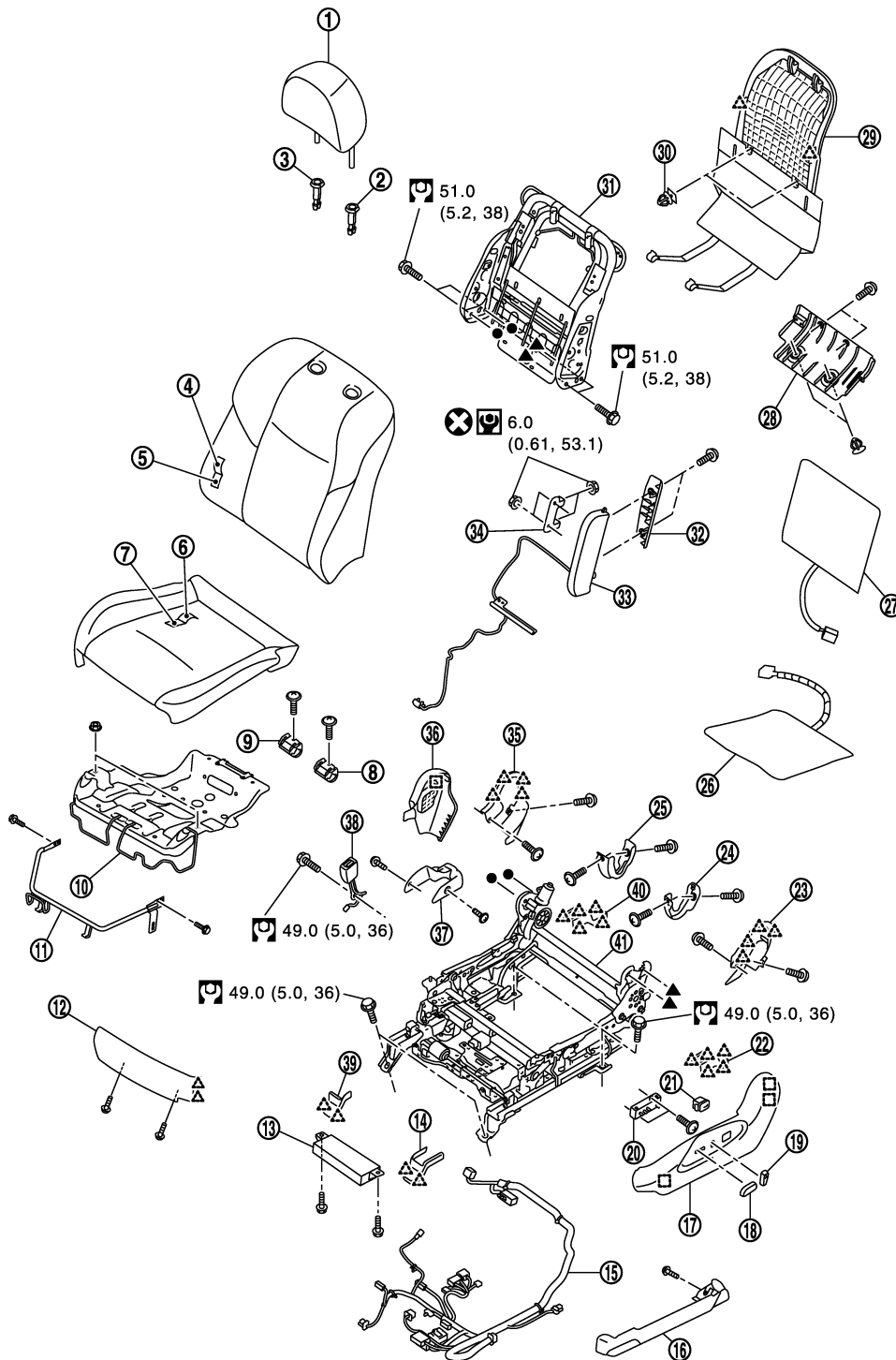

A
B
C
D
E
F
G
H
I
SE
K
L
M
N
O
P

JMJIA4128GB

FRONT SEAT

< REMOVAL AND INSTALLATION >

- | | | |
|---------------------------------------|--------------------------------------|---------------------------------------|
| 1. Headrest | 2. Headrest holder (locked) | 3. Headrest holder (free) |
| 4. Seatback trim | 5. Seatback pad | 6. Seat cushion trim |
| 7. Seat cushion pad | 8. Seat cushion frame bracket (LH) | 9. Seat cushion frame bracket (RH) |
| 10. Seat cushion frame | 11. Seat adjuster bar | 12. Seat cushion finisher (front) |
| 13. Seat control unit | 14. Front leg outer cover | 15. Seat harness |
| 16. Seat cushion lower outer finisher | 17. Seat cushion outer finisher (LH) | 18. Seat slide and lifter switch knob |
| 19. Seat reclining switch knob | 20. Seat control switch | 21. Lumber support switch |
| 22. Rear leg outer cover | 23. Seat cushion inner finisher (LH) | 24. Seat cushion rear finisher (LH) |
| 25. Seat cushion rear finisher (RH) | 26. Seat cushion heater unit | 27. Seatback heater unit |
| 28. Seat cushion rear finisher | 29. Seatback board | 30. Seatback board clip |
| 31. Seatback frame | 32. Side air bag module cover | 33. Side air bag module |
| 34. Side air bag module bracket | 35. Seat cushion inner finisher (RH) | 36. Seat cushion outer finisher (RH) |
| 37. Seat cushion lower inner finisher | 38. Seat belt buckle | 39. Front leg inner cover |
| 40. Rear leg inner cover | 41. Seat adjuster assembly | |

 : Pawl

 : Metal clip

Refer to [GI-4, "Components"](#) for symbols in the figure.

DRIVER SEAT WITH SEAT SPEAKER AND CLIMATE CONTROLLED SEAT

FRONT SEAT

< REMOVAL AND INSTALLATION >

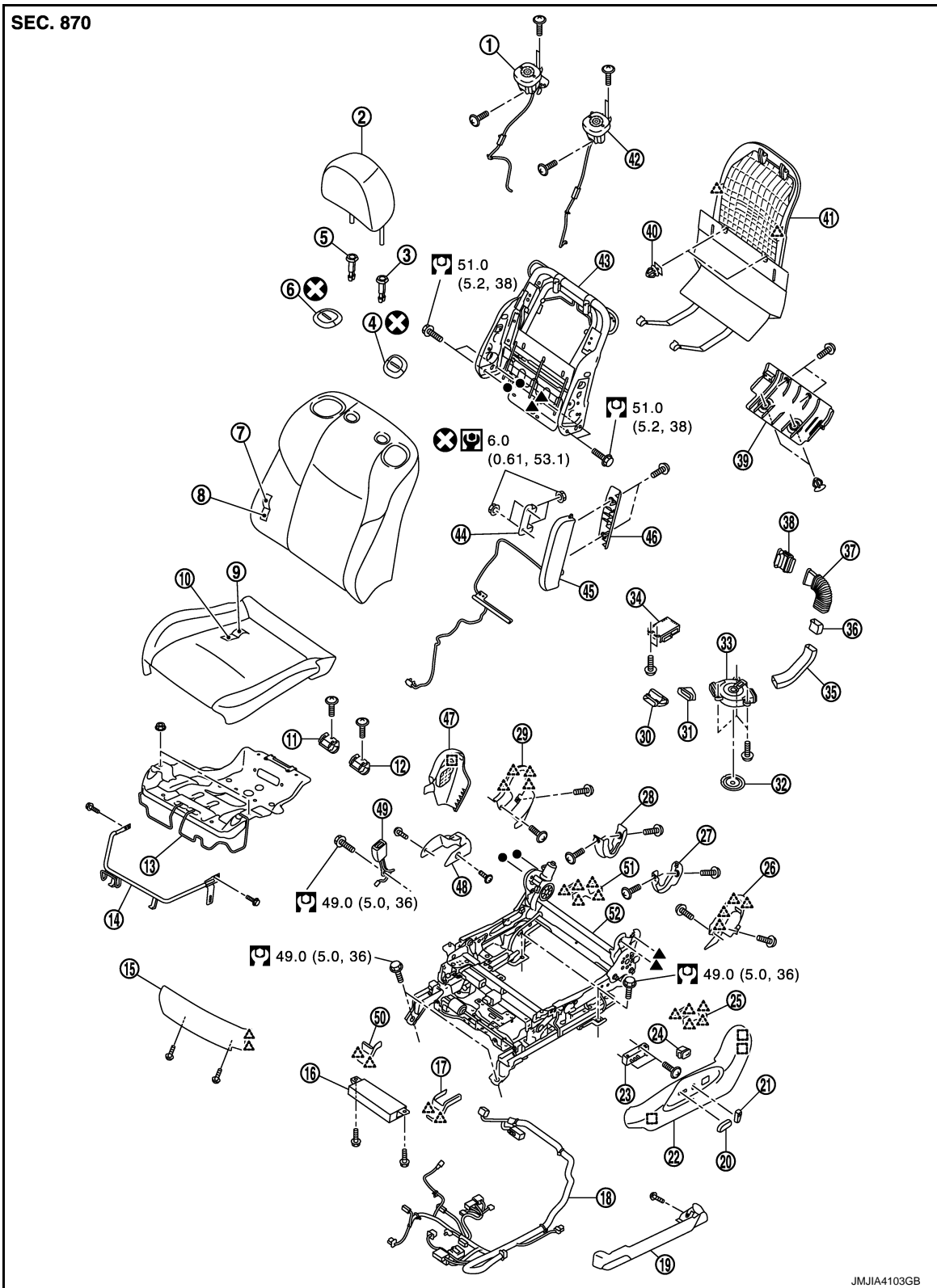

- | | | |
|----------------------------|-------------------------------------|-------------------------------------|
| 1. Seat speaker (RH) | 2. Headrest | 3. Headrest holder (locked) |
| 4. Seat speaker grill (LH) | 5. Headrest holder (free) | 6. Seat speaker grill (RH) |
| 7. Seatback trim | 8. Seatback pad | 9. Seat cushion trim |
| 10. Seat cushion pad | 11. Seat cushion frame bracket (RH) | 12. Seat cushion frame bracket (LH) |
| 13. Seat cushion frame | 14. Seat adjuster bar | 15. Seat cushion finisher (front) |
| 16. Seat control unit | 17. Front leg outer cover | 18. Seat harness |

FRONT SEAT

< REMOVAL AND INSTALLATION >

- | | | |
|--|---|--|
| 19. Seat cushion lower outer finisher | 20. Seat slide and lifter switch knob | 21. Seat reclining switch knob |
| 22. Seat cushion outer finisher (LH) | 23. Seat control switch | 24. Lumber support switch |
| 25. Rear leg outer cover | 26. Seat cushion inner finisher (LH) | 27. Seat cushion rear finisher (LH) |
| 28. Seat cushion rear finisher (RH) | 29. Seat cushion inner finisher (RH) | 30. Seat cushion thermal electric unit |
| 31. Seat cushion duct | 32. Climate controlled seat blower filter | 33. Climate controlled seat blower motor |
| 34. Climate controlled seat control unit | 35. Seatback duct | 36. Seatback duct |
| 37. Seatback duct | 38. Seatback thermal electric unit | 39. Seat cushion rear finisher |
| 40. Seatback board clip | 41. Seatback board | 42. Seat speaker (LH) |
| 43. Seatback frame | 44. Side air bag module bracket | 45. Side air bag module |
| 46. Side air bag module cover | 47. Seat cushion outer finisher (RH) | 48. Seat cushion lower inner finisher |
| 49. Seat belt buckle | 50. Front leg inner cover | 51. Rear leg inner cover |
| 52. Seat adjuster assembly | | |

 : Pawl

 : Metal clip

Refer to [GI-4. "Components"](#) for symbols in the figure.

PASSENGER SEAT WITH SEAT HEATER

FRONT SEAT

< REMOVAL AND INSTALLATION >

SEC. 870

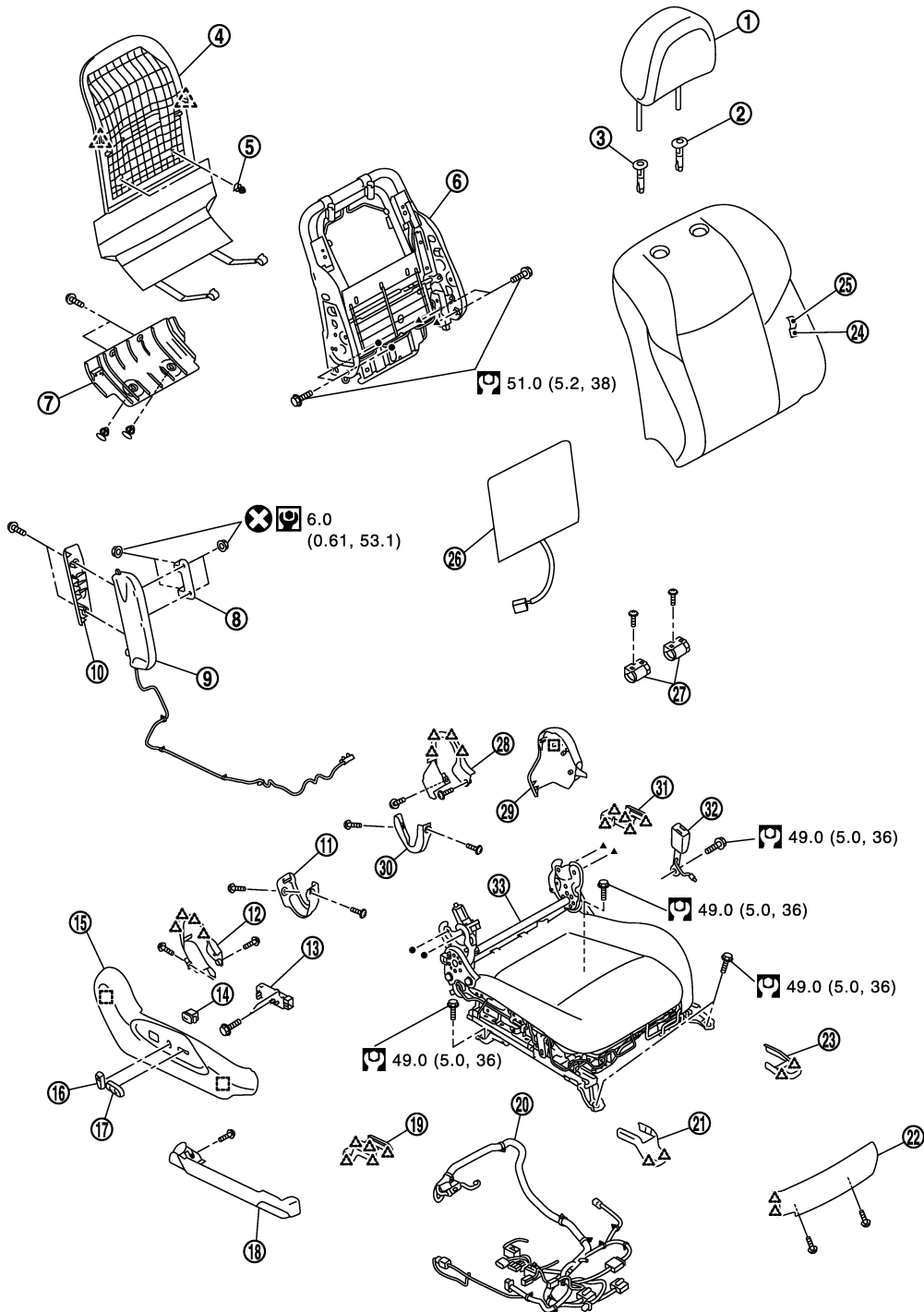

JMJIA4129GB

- | | | |
|--------------------------------|---------------------------------------|---------------------------------------|
| 1. Headrest | 2. Headrest holder (locked) | 3. Headrest holder (free) |
| 4. Seatback board | 5. Seatback board clip | 6. Seatback frame |
| 7. Seat cushion rear finisher | 8. Side air bag module bracket | 9. Side air bag module |
| 10. Side air bag module cover | 11. Seat cushion rear finisher (RH) | 12. Seat cushion inner finisher (LH) |
| 13. Seat control switch | 14. Lumbar support switch | 15. Seat cushion outer finisher (RH) |
| 16. Seat reclining switch knob | 17. Seat slide and lifter switch knob | 18. Seat cushion lower outer finisher |

A
B
C
D
E
F
G
H
I
SE
K
L
M
N
O
P

FRONT SEAT

< REMOVAL AND INSTALLATION >

- | | | |
|--------------------------------------|--------------------------------------|-------------------------------------|
| 19. Rear leg outer cover | 20. Seat harness | 21. Front leg outer cover |
| 22. Seat cushion finisher (front) | 23. Front leg inner cover | 24. Seatback pad |
| 25. Seatback trim | 26. Seatback heater unit | 27. Seat cushion frame bracket |
| 28. Seat cushion inner finisher (LH) | 29. Seat cushion outer finisher (RH) | 30. Seat cushion rear finisher (LH) |
| 31. Rear leg inner cover | 32. Seat belt buckle | 33. Seat cushion assembly |

 : Pawl

 : Metal clip

Refer to [GI-4, "Components"](#) for symbols in the figure.

PASSENGER SEAT WITH SEAT SPEAKER AND CLIMATE CONTROLLED SEAT

FRONT SEAT

< REMOVAL AND INSTALLATION >

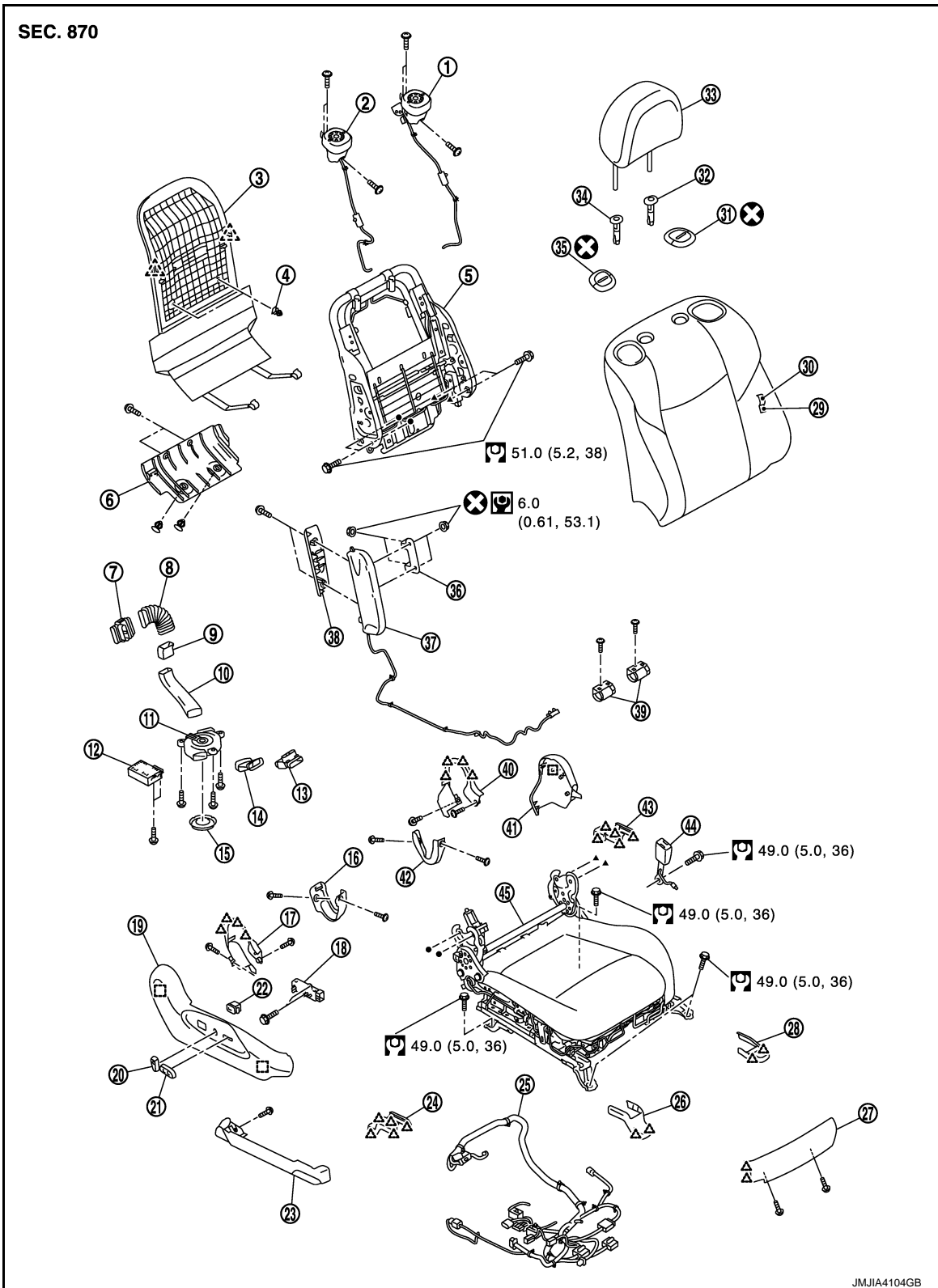

- | | | |
|--|--|---|
| 1. Seat speaker (LH) | 2. Seat speaker (RH) | 3. Seatback board |
| 4. Seatback board clip | 5. Seatback frame | 6. Seat cushion rear finisher |
| 7. Seatback thermal electric unit | 8. Seatback duct | 9. Seatback duct |
| 10. Seatback duct | 11. Climate controlled seat blower motor | 12. Climate controlled seat control unit |
| 13. Seat cushion thermal electric unit | 14. Seat cushion duct | 15. Climate controlled seat blower filter |
| 16. Seat cushion rear finisher (RH) | 17. Seat cushion inner finisher (LH) | 18. Seat control switch |

FRONT SEAT

< REMOVAL AND INSTALLATION >

- | | | |
|---------------------------------------|---------------------------------------|-------------------------------------|
| 19. Lumber support switch | 20. Seat cushion outer finisher (RH) | 21. Seat reclining switch knob |
| 22. Seat slide and lifter switch knob | 23. Seat cushion lower outer finisher | 24. Rear leg outer cover |
| 25. Seat harness | 26. Front leg outer cover | 27. Seat cushion finisher (front) |
| 28. Front leg inner cover | 29. Seatback pad | 30. Seatback trim |
| 31. Seat speaker grill (LH) | 32. Headrest holder (locked) | 33. Headrest |
| 34. Headrest holder (free) | 35. Seat speaker grill (RH) | 36. Side air bag module bracket |
| 37. Side air bag module | 38. Side air bag module cover | 39. Seat cushion frame bracket |
| 40. Seat cushion inner finisher (LH) | 41. Seat cushion outer finisher (RH) | 42. Seat cushion rear finisher (LH) |
| 43. Rear leg inner cover | 44. Seat belt buckle | 45. Seat cushion assembly |

 : Pawl

 : Metal clip

Refer to [GI-4, "Components"](#) for symbols in the figure.

Removal and Installation

INFOID:000000006046718

REMOVAL

CAUTION:

When removing and installing, use shop cloths to protect parts from damage.

1. Remove the headrest.
2. Remove the front leg cover.
 - a. Front outer leg cover
 - Slide the seat to the rearmost position.
 - Pull front leg cover outer front clips upward to disengage.
 - Slide front leg cover outer foreword to remove.

 : Pawl

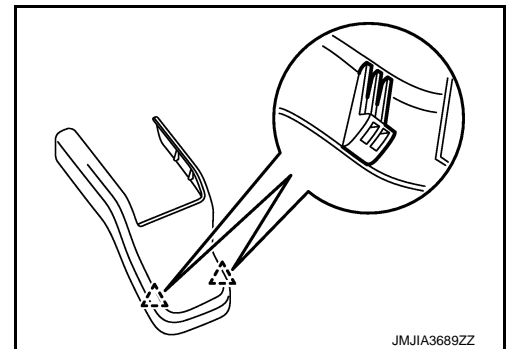

- b. Front inner leg cover
 - Slide seat to the rearmost position.
 - Pull front leg cover inner front pawls upward to disengage.
 - Slide front leg cover foreword to remove.

 : Pawl

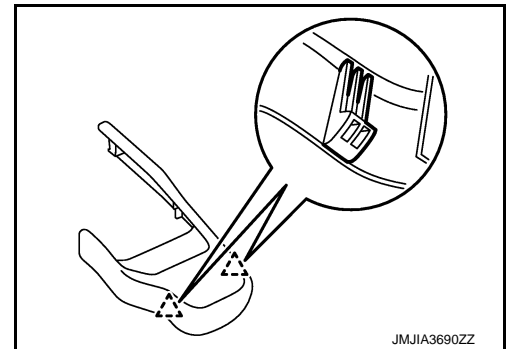

3. Remove mounting bolts from the front of front seat.
4. Remove rear leg covers.

FRONT SEAT

< REMOVAL AND INSTALLATION >

- a. Rear outer leg cover
- Slide seat to the frontmost position.
 - Pull rear leg cover outer rear pawls upward to disengage and remove.
 - Open rear leg cover inner front, and then disengage and remove pawls.

 : Pawl

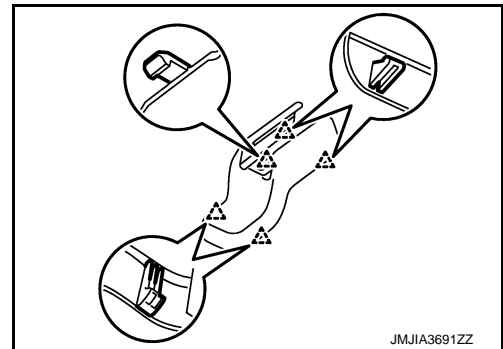

- b. Rear inner leg cover
- Slide the seat to the frontmost position.
 - Pull rear leg cover inner rear pawls upward to disengage and remove.
 - Open rear leg cover inner front, and then disengage and remove pawls.

 : Pawl

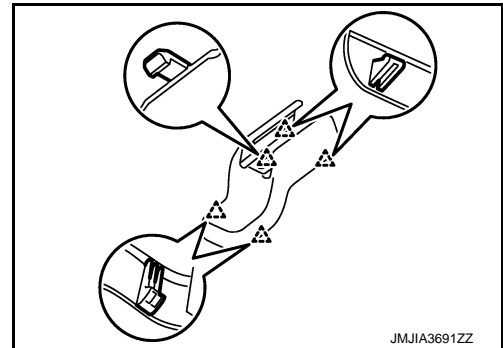

5. Remove mounting bolts from the front seat rear side.
 6. Set the seatback vertically.
 7. Remove seat cushion lower harness connector and harness clamp.

CAUTION:

Before removal, turn ignition switch OFF, disconnect battery negative terminal and then wait for at least 3 minutes.

8. Remove the front seat from the vehicle.

CAUTION:

When removing and installing, use shop cloths to protect parts from damage.

INSTALLATION

Note the following item, and then install in the reverse order of removal.

CAUTION:

Always fix the harness clamp in position.

NOTE:

Perform "Operation when disconnecting battery cable from negative terminal" after connecting the battery cable to the negative terminal. Refer to [ADP-57. "ADDITIONAL SERVICE WHEN REMOVING BATTERY NEGATIVE TERMINAL : Description"](#).

SEATBACK

SEATBACK : Disassembly and Assembly

INFOID:000000006046719

Disassembly

1. Remove the seatback board.
1. Pull seatback board forward. Disengage clips of lower side, and then disengage pawls.
 2. Pull seatback board downward. Remove seatback board.

 : Clip

 : Pawl

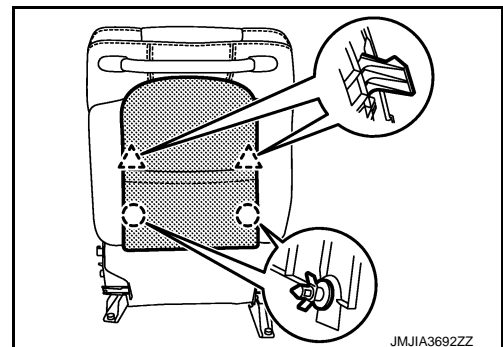

FRONT SEAT

< REMOVAL AND INSTALLATION >

2. Remove seatback trim and seatback pad.

1. Remove seatback retainer (A).
2. Remove mounting clips (B).

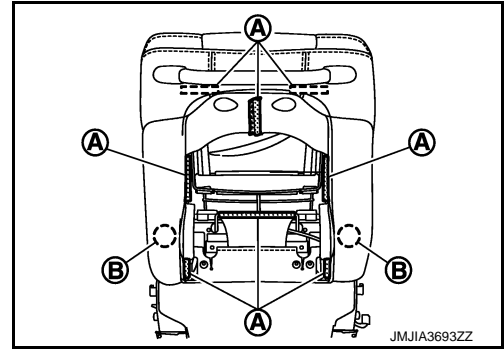

3. Disconnect the seatback heater unit harness connector. (Heated seat model only.)

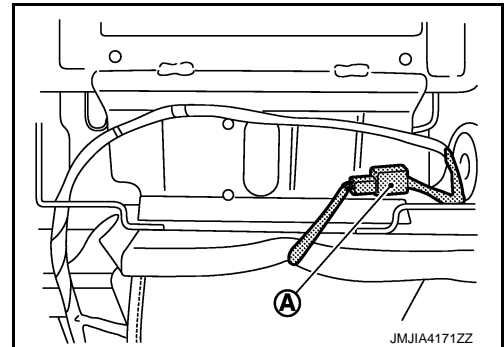

4. Remove the headrest holder.

CAUTION:

Before installing headrest holder check its orientation. (Front/rear and right/left)

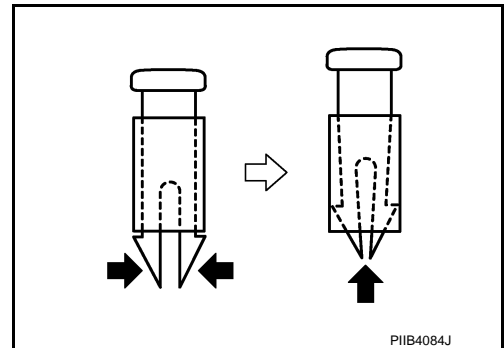

5. Remove the side air bag module cover.

6. Remove the side air bag module mounting nuts. Refer to [SR-17. "Removal and Installation"](#).

7. Remove the speaker grill (seat with speaker only). Refer to [AV-306. "Removal and Installation"](#).

8. Remove the seatback trim and seatback pad from the seatback frame.

NOTE:

For models with seat heater, remove seatback heater unit, seatback trim, and seatback pad as a set.

9. Remove the hog rings, and separate the seatback trim and seatback pad.

3. Remove the seatback silencer.

4. Remove the seatback thermal electric unit harness connector (A).

5. Remove the harness clips (B).

6. Cut mounting band (C) of seatback thermal electric unit.

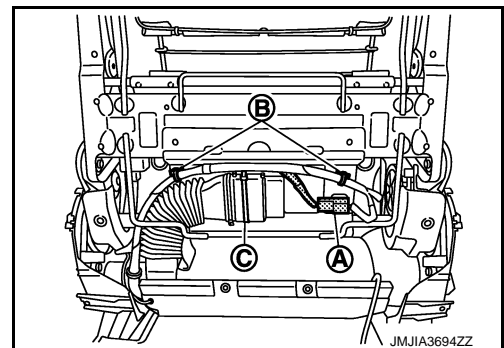

FRONT SEAT

< REMOVAL AND INSTALLATION >

7. Disconnect seatback speaker harness connector (A), reclining motor harness connector (B), Lumbar support motor harness connector (C), and harness clip (D).

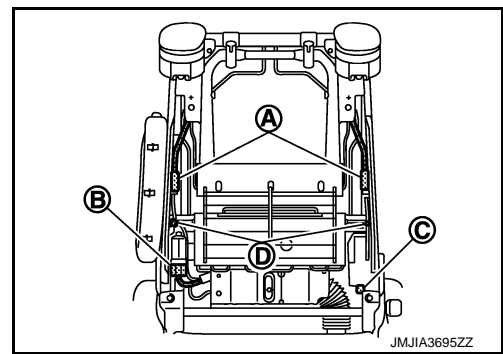

8. Remove mounting bolts, and then remove seatback frame.

Assembly

Note the following item, and then assembly in the reverse order of disassembly.

CAUTION:

- Install the hog rings of seat trim in position, and then securely connect the trim or trim cord with the pad side wire.
- Apply door regulator grease or an equivalent to shaft and gear positions of lumbar support unit. (Models with power lumbar support only)

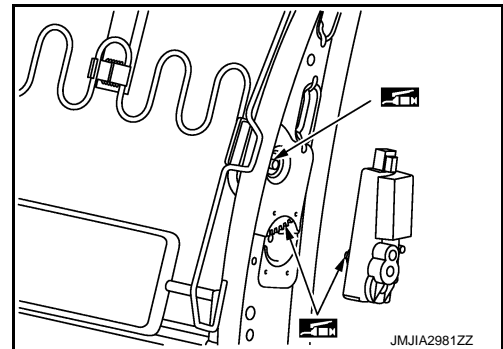

SEAT CUSHION

SEAT CUSHION : Disassembly and Assembly

INFOID:000000006088129

Disassembly

CAUTION:

Do not disassemble front passenger seat cushion assembly (USA/Canada model only).

Always replace as an assembly.

For front passenger seat service parts, refer to the service part catalogue.

1. Remove the seat cushion outer finisher.
 1. Remove the seat slide & lifter switch and seat reclining switch (1) knob (2) using a remover tool.

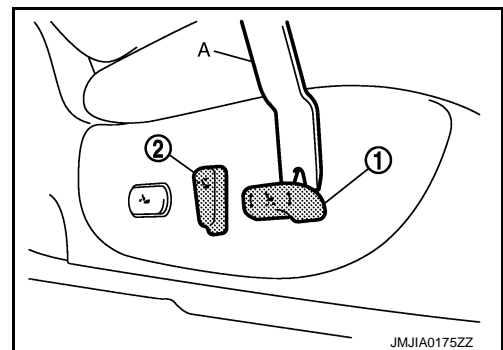

FRONT SEAT

< REMOVAL AND INSTALLATION >

2. Pull seat cushion outer finisher forward. Disengage metal clips and pawls.

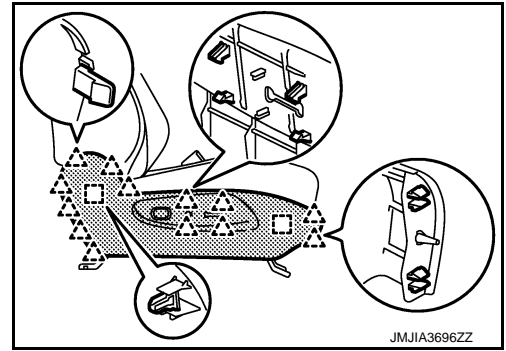
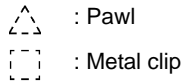

3. Remove the lumbar support switch harness connector.
2. Remove the seat cushion inner finisher.
Pull seat cushion inner finisher forward. Disengage pawls and metal clips.

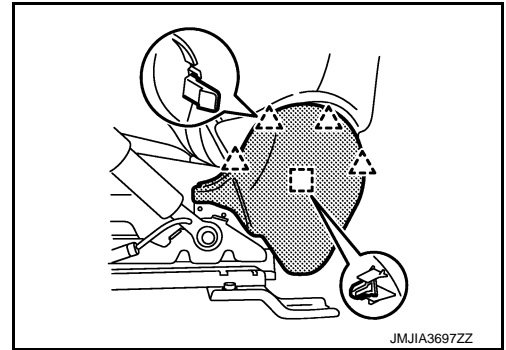
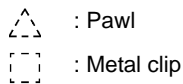

3. Remove the seatback trim and seatback pad from the seatback frame.
Refer to [SE-109. "SEATBACK : Disassembly and Assembly"](#).
4. Remove the seatback silencer.
5. Remove the seatback thermal electric unit harness connector (A).
6. Remove the harness clips (B).
7. Cut mounting band (C) of seatback thermal electric unit.

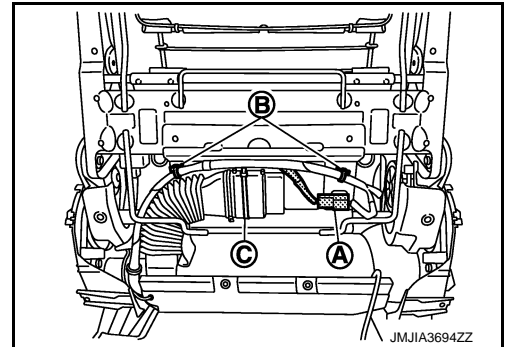

8. Disconnect seatback speaker harness connector (A), reclining motor harness connector (B), lumbar support motor harness connector (C), and harness clip (D).

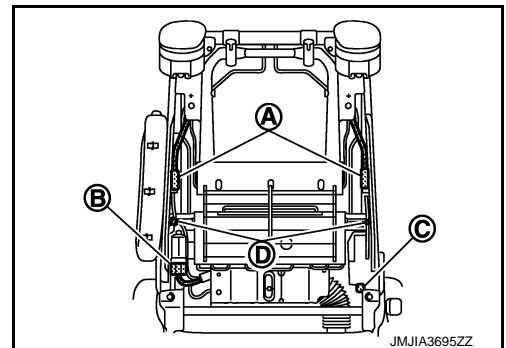

FRONT SEAT

< REMOVAL AND INSTALLATION >

9. Remove the mounting screw (A). Remove the seat cushion front finisher.

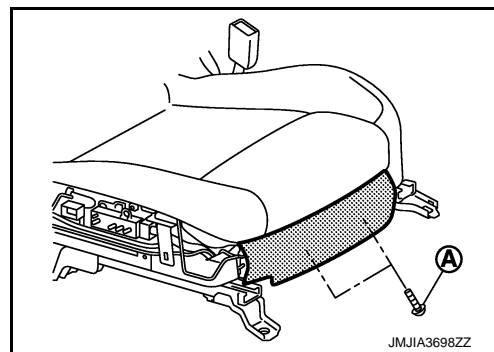

10. Remove the seat cushion rear finisher.
11. Disconnect the seatback heater unit harness connector. (Heated seat model only.)

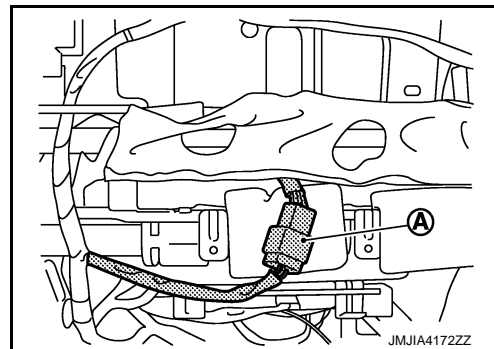

12. Disconnect harness connector (A) and harness clip (B) of seat cushion frame lower.
• Driver's seat

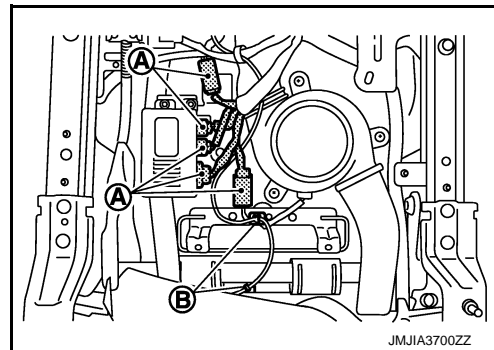

- Passenger's seat

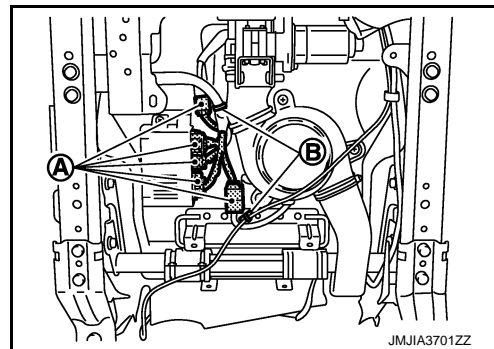

13. Remove the mounting nut and screw. Remove seat cushion frame.
14. Remove the thermal electric unit from seat cushion frame.
15. Remove the seat cushion trim and seat cushion pad.
1. Remove the seat cushion retainer.
2. Remove the seat cushion trim and seat cushion pad from the seat cushion frame.

NOTE:

A
B
C
D
E
F
G
H
I
SE
K
L
M
N
O
P

FRONT SEAT

< REMOVAL AND INSTALLATION >

For models with seat heater, remove seat cushion heater unit, seat cushion trim, and seat cushion pad as a set.

3. Remove the hog rings, and separate the seat cushion trim and seat cushion pad.
16. Remove the following parts from seat adjuster assembly.
 - Seat cushion inner finisher
 - Seat cushion rear finisher
 - Seat cushion outer finisher lower
 - Seat belt buckle: Refer to [SB-8, "SEAT BELT BUCKLE : Removal and Installation"](#).

Assembly

Note the following item, and then assembly in the reverse order of disassembly.

CAUTION:

- Install the hog rings of seat trim in position, and then securely connect the trim or trim cord with the pad side wire.
- Apply door regulator grease or an equivalent to shaft and gear positions of lumber support unit. (Models with power lumber support only)

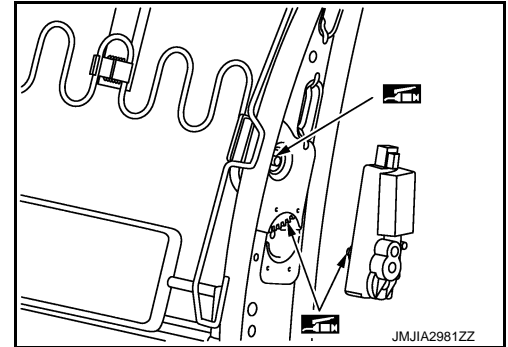

CLIMATE CONTROLLED SEAT UNIT

CLIMATE CONTROLLED SEAT UNIT : Disassembly and Assembly

INFOID:000000006088131

Disassembly

1. Remove the seatback duct and seatback thermal electric unit.
 1. Remove the harness connector (A).
 2. Remove the band (B).

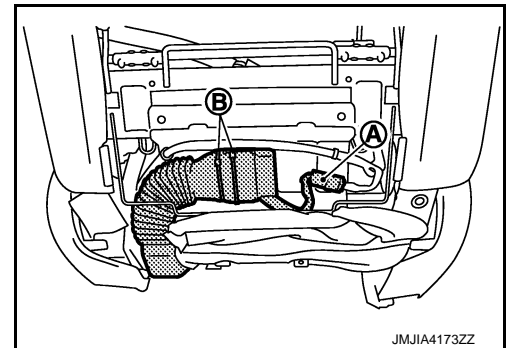

2. Remove the seatback duct.
3. Remove the seat cushion duct, seat cushion thermal electric unit and climate controlled seat blower motor.
 1. Disconnect the harness connectors (A).
 2. Remove the band (B)
 3. Remove the climate controlled seat blower motor mounting screws (C).

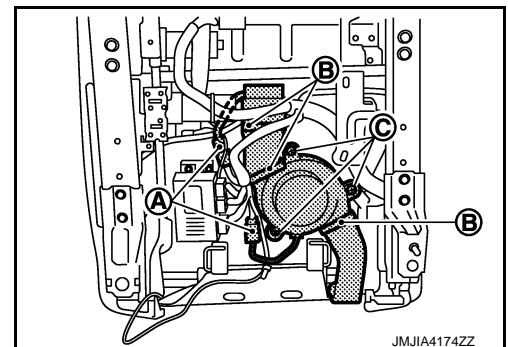

FRONT SEAT

< REMOVAL AND INSTALLATION >

4. Remove the seat cushion duct.
5. Remove the climate controlled seat control unit.
 1. Disconnect the harness connectors (A).
 2. Remove the climate controlled seat control unit mounting screws (B).

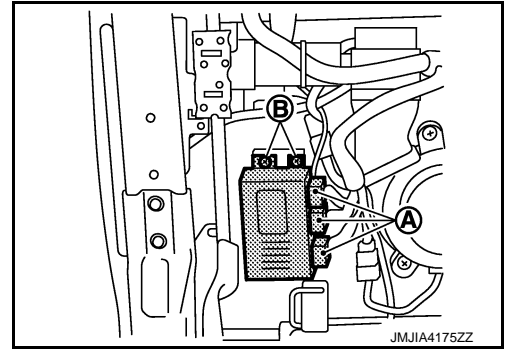

Assembly

Assemble in the reverse order of disassembly.

A
B
C
D
E
F
G
H
I
K
L
M
N
O
P

SE

REAR SEAT

< REMOVAL AND INSTALLATION >

REAR SEAT

Exploded View

INFOID:000000006046720

SEC. 880

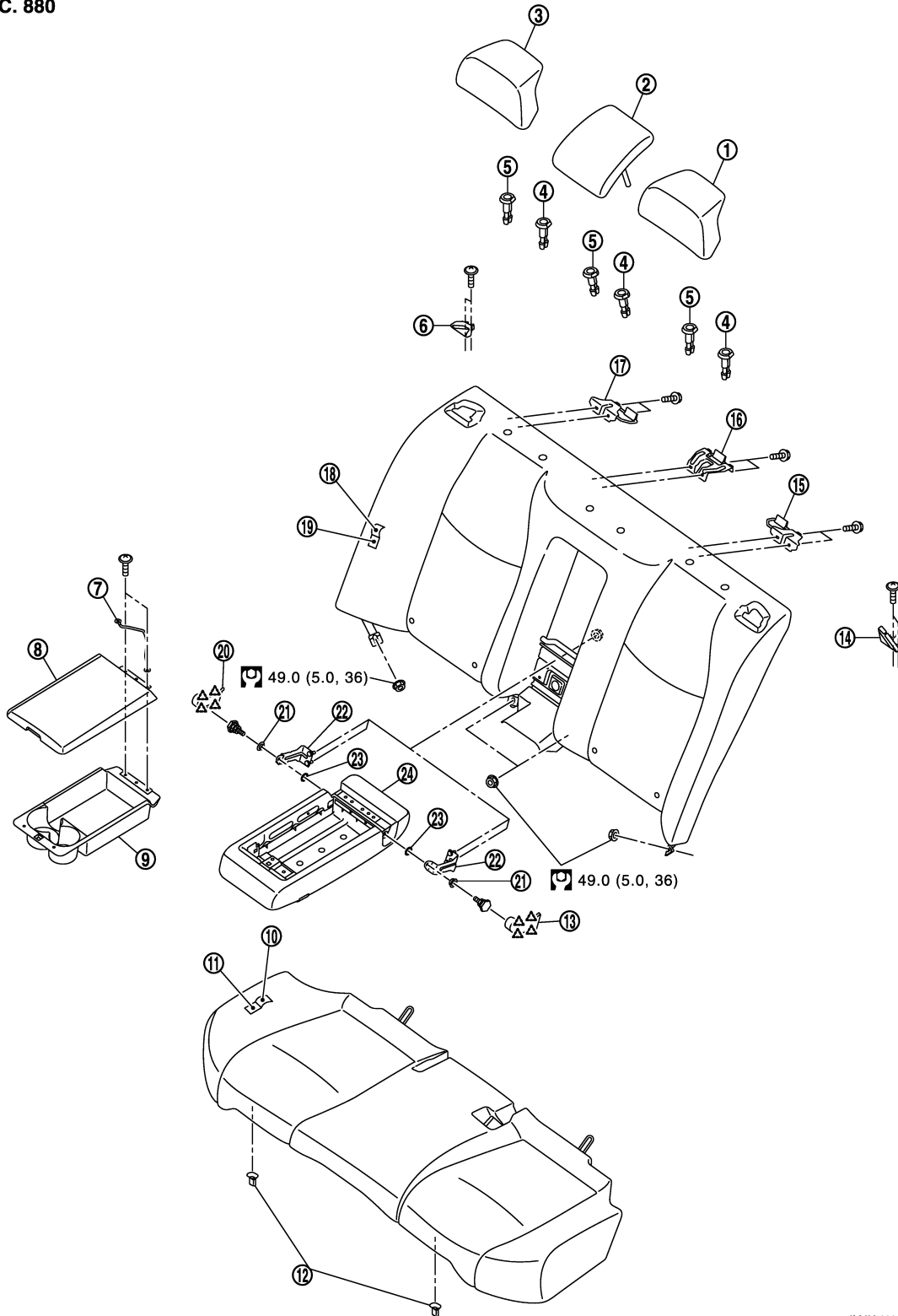

JMJIA4118GB

- | | | |
|-----------------------------|---------------------------|------------------------------|
| 1. Headrest (LH) | 2. Center headrest | 3. Headrest (RH) |
| 4. Headrest holder (locked) | 5. Headrest holder (free) | 6. Seat belt guide (RH) |
| 7. Earth wire | 8. Center armrest lid | 9. Center armrest try & tray |

REAR SEAT

< REMOVAL AND INSTALLATION >

- | | | |
|--|--|-------------------------------|
| 10. Seat cushion trim | 11. Seat cushion pad | 12. Seat cushion hook |
| 13. Center armrest hinge escutcheon (LH) | 14. Seat belt guide (LH) | 15. Seatback bracket (LH) |
| 16. Center seatback bracket | 17. Seatback bracket (LH) | 18. Seatback trim |
| 19. Seatback pad | 20. Center armrest hinge escutcheon (RH) | 21. Center armrest bush |
| 22. Center armrest hinge | 23. Center armrest washer | 24. Center armrest trim & pad |

: pawl

Refer to [GI-4, "Components"](#) for symbols in the figure.

Removal and Installation

INFOID:000000006046721

REMOVAL

CAUTION:

When removing and installing, use shop cloths to protect parts from damage.

1. Lift up seat cushion. Disengage seat cushion hook. Remove seat cushion.
2. Remove all rear headrests.
3. Remove mounting nuts of seatback.
4. Lift up seatback, release wire on back of seatback from seatback hook and then remove seatback.
5. Remove mounting nuts from back of seatback. Remove center armrest.

INSTALLATION

Install in the reverse order of removal.

Disassembly and Assembly

INFOID:000000006046722

SEATBACK

DISASSEMBLY

1. Remove mounting bolts, and then remove seat belt guide LH and RH.
2. Remove mounting bolts. Remove seatback bracket (LH), seatback bracket (RH) and center seatback bracket.
3. Remove the headrest holder.

CAUTION:

Before installing headrest holder check its orientation. (front/rear and right/left)

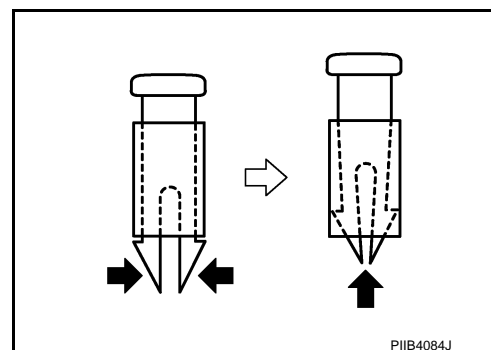

4. Remove hog rings and remove seatback trim from seatback pad.

ASSEMBLY

Assemble in the reverse order of disassembly.

CAUTION:

Install the hog rings of seat trim in position, and then securely connect the trim or trim cord with the pad side wire.

SEAT CUSHION

DISASSEMBLY

Remove hog rings and remove seat cushion trim from seat cushion pad.

ASSEMBLY

Assemble in the reverse order of disassembly.

REAR SEAT

< REMOVAL AND INSTALLATION >

CAUTION:

Install the hog rings of seat trim in position, and then securely connect the trim or trim cord with the pad side wire.

ARMREST

DISASSEMBLY

1. Remove mounting screws. Remove center armrest lid.
2. Slide center armrest tray & box. Disengage pawls. Remove center armrest tray & box.

 : Pawl

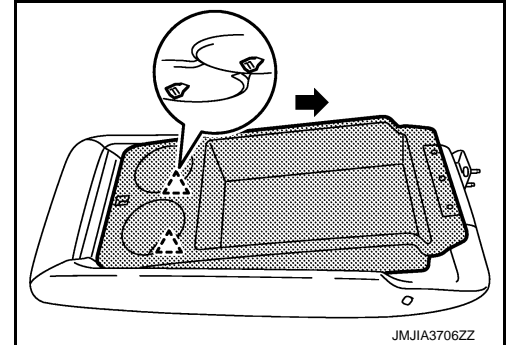

3. Remove center armrest hinge escutcheon.
4. Remove mounting bolts. Remove center armrest hinge.

ASSEMBLY

Assemble in the reverse order of disassembly.

POWER SEAT SWITCH

< REMOVAL AND INSTALLATION >

POWER SEAT SWITCH

Exploded View

INFOID:000000005986927

Refer to [SE-101, "Exploded View"](#).

Removal and Installation

INFOID:000000005986928

REMOVAL

CAUTION:

When removing and installing, use shop cloths to protect parts from damage.

1. Remove front seat. Refer to [SE-108, "Removal and Installation"](#).
2. Remove seat cushion outer finisher. Refer to [SE-111, "SEAT CUSHION : Disassembly and Assembly"](#).
3. Disconnect power seat switch connector.
4. Remove screws.
5. Remove power seat switch from seat cushion outer finisher.

NOTE:

The same procedure is also performed for passenger side.

INSTALLATION

Install in the reverse order of removal.

CAUTION:

Always clamp the harness to the right place.

A
B
C
D
E
F
G
H
I
K
L
M
N
O
P

SE

HEATED SEAT SWITCH

< REMOVAL AND INSTALLATION >

HEATED SEAT SWITCH

Exploded View

INFOID:000000006059678

Refer to [IP-23, "Exploded View"](#).

Removal and Installation

INFOID:000000006062120

REMOVAL

CAUTION:

When removing and installing, use shop cloths to protect parts from damage.

1. Remove console finisher assembly from center console assembly. Refer to [IP-24, "Removal and Installation"](#).
2. Remove console indicator finisher from console finisher assembly. Refer to [IP-27, "Disassembly and Assembly"](#).
3. Disconnect heated seat switch connector.
4. Remove heated seat switch from switch panel using a flat-bladed screwdriver.

INSTALLATION

Install in the reverse order of removal.

CAUTION:

Always clamp the harness to the right place.

CLIMATE CONTROLLED SEAT SWITCH

< REMOVAL AND INSTALLATION >

CLIMATE CONTROLLED SEAT SWITCH

Exploded View

INFOID:000000005986931

Refer to [IP-23, "Exploded View"](#).

Removal and Installation

INFOID:000000005986932

REMOVAL

CAUTION:

When removing and installing, use shop cloths to protect parts from damage.

1. Remove console finisher assembly from center console assembly. Refer to [IP-24, "Removal and Installation"](#).
2. Remove console indicator finisher from console finisher assembly. Refer to [IP-27, "Disassembly and Assembly"](#).
3. Disconnect climate controlled seat switch connector.
4. Remove climate controlled seat switch from switch panel using a flat-bladed screwdriver.

INSTALLATION

Install in the reverse order of removal.

CAUTION:

Always clamp the harness to the right place.

A
B
C
D
E
F
G
H
I
K
L
M
N
O
P

SE

CLIMATE CONTROLLED SEAT BLOWER FILTER

< REMOVAL AND INSTALLATION >

CLIMATE CONTROLLED SEAT BLOWER FILTER

Exploded View

INFOID:000000005986933

Refer to [SE-101, "Exploded View"](#).

Removal and Installation

INFOID:000000005986934

REMOVAL

CAUTION:

When removing and installing, use shop cloths to protect parts from damage.

1. Remove front seat. Refer to [SE-108, "Removal and Installation"](#).
2. Turn blower filter counter clockwise and remove it from climate controlled seat cushion blower motor.

NOTE:

The same procedure is also performed for passenger side.

INSTALLATION

Install in the reverse order of removal.