

SECTION PCS

POWER CONTROL SYSTEM

A
B
C
D
E
F
G
H
I
J
K
L
N
O
P

CONTENTS

<p>IPDM E/R</p> <p>PRECAUTION 3</p> <p>PRECAUTIONS 3</p> <p> Precaution for Supplemental Restraint System (SRS) "AIR BAG" and "SEAT BELT PRE-TENSIONER"3</p> <p> Precautions Necessary for Steering Wheel Rotation After Battery Disconnection3</p> <p> Precaution for Procedure without Cowl Top Cover....4</p> <p>SYSTEM DESCRIPTION 5</p> <p>COMPONENT PARTS 5</p> <p>IPDM E/R5</p> <p> IPDM E/R : Component Parts Location5</p> <p>SYSTEM 6</p> <p>RELAY CONTROL SYSTEM6</p> <p> RELAY CONTROL SYSTEM : System Diagram6</p> <p> RELAY CONTROL SYSTEM : System Description6</p> <p> RELAY CONTROL SYSTEM : Fail-safe7</p> <p>POWER CONTROL SYSTEM9</p> <p> POWER CONTROL SYSTEM : System Diagram....9</p> <p> POWER CONTROL SYSTEM : System Description9</p> <p>SIGNAL BUFFER SYSTEM9</p> <p> SIGNAL BUFFER SYSTEM : System Diagram9</p> <p> SIGNAL BUFFER SYSTEM : System Description... 10</p> <p>POWER CONSUMPTION CONTROL SYSTEM 10</p> <p> POWER CONSUMPTION CONTROL SYSTEM : System Diagram 10</p> <p> POWER CONSUMPTION CONTROL SYSTEM : System Description 10</p> <p>DIAGNOSIS SYSTEM (IPDM E/R)12</p>	<p> Diagnosis Description12</p> <p> CONSULT Function (IPDM E/R)14</p> <p>ECU DIAGNOSIS INFORMATION17</p> <p>IPDM E/R17</p> <p> Reference Value17</p> <p> Fail-safe24</p> <p> DTC Index25</p> <p>WIRING DIAGRAM27</p> <p>IPDM E/R27</p> <p> Wiring Diagram27</p> <p>DTC/CIRCUIT DIAGNOSIS29</p> <p>U1000 CAN COMM CIRCUIT29</p> <p> Description29</p> <p> DTC Logic29</p> <p> Diagnosis Procedure29</p> <p>B2098 IGNITION RELAY ON STUCK30</p> <p> Description30</p> <p> DTC Logic30</p> <p> Diagnosis Procedure30</p> <p>B2099 IGNITION RELAY OFF STUCK31</p> <p> Description31</p> <p> DTC Logic31</p> <p> Diagnosis Procedure31</p> <p>POWER SUPPLY AND GROUND CIRCUIT32</p> <p> Diagnosis Procedure32</p> <p>REMOVAL AND INSTALLATION33</p> <p>IPDM E/R33</p> <p> Exploded View33</p> <p> Removal and Installation33</p> <p>POWER DISTRIBUTION SYSTEM</p> <p>PRECAUTION35</p>
--	--

PCS

PRECAUTIONS	35	B2615 BLOWER RELAY CIRCUIT	58
Precaution for Supplemental Restraint System (SRS) "AIR BAG" and "SEAT BELT PRE-TENSIONER"	35	DTC Logic	58
Precautions Necessary for Steering Wheel Rotation After Battery Disconnection	35	Diagnosis Procedure	58
		Component Inspection	59
SYSTEM DESCRIPTION	37	B2616 IGNITION RELAY CIRCUIT	60
COMPONENT PARTS	37	DTC Logic	60
Component Parts Location	37	Diagnosis Procedure	60
Component Description	37	Component Inspection	61
BCM	37	B2618 BCM	62
Ignition Relay	37	DTC Logic	62
Accessory Relay	38	Diagnosis Procedure	62
Blower Relay	38	B261A PUSH-BUTTON IGNITION SWITCH	63
Push-Button Ignition Switch	38	DTC Logic	63
		Diagnosis Procedure	63
SYSTEM	39	B26F1 IGNITION RELAY	65
POWER DISTRIBUTION SYSTEM	39	DTC Logic	65
POWER DISTRIBUTION SYSTEM : System Diagram	39	Diagnosis Procedure	65
POWER DISTRIBUTION SYSTEM : System Description	39	B26F2 IGNITION RELAY	67
Fail-safe	40	DTC Logic	67
		Diagnosis Procedure	67
DIAGNOSIS SYSTEM (BCM)	43	B26F6 BCM	69
COMMON ITEM	43	DTC Logic	69
COMMON ITEM : CONSULT Function (BCM - COMMON ITEM)	43	Diagnosis Procedure	69
INTELLIGENT KEY	44	PUSH-BUTTON IGNITION SWITCH	70
INTELLIGENT KEY : CONSULT Function (BCM - INTELLIGENT KEY)	44	Component Function Check	70
		Diagnosis Procedure	70
ECU DIAGNOSIS INFORMATION	49	Component Inspection	71
BCM	49	PUSH-BUTTON IGNITION SWITCH POSITION INDICATOR	73
List of ECU Reference	49	Description	73
WIRING DIAGRAM	50	Component Function Check	73
POWER DISTRIBUTION SYSTEM	50	Diagnosis Procedure	73
Wiring Diagram	50	SYMPTOM DIAGNOSIS	75
BASIC INSPECTION	52	PUSH-BUTTON IGNITION SWITCH DOES NOT OPERATE	75
DIAGNOSIS AND REPAIR WORK FLOW	52	Description	75
Work Flow	52	Diagnosis Procedure	75
DTC/CIRCUIT DIAGNOSIS	55	PUSH-BUTTON IGNITION SWITCH POSITION INDICATOR DOES NOT ILLUMINATE	76
B2614 ACC RELAY CIRCUIT	55	Description	76
DTC Logic	55	Diagnosis Procedure	76
Diagnosis Procedure	55	REMOVAL AND INSTALLATION	77
Component Inspection	56	PUSH-BUTTON IGNITION SWITCH	77
		Exploded View	77
		Removal and Installation	77

PRECAUTION

PRECAUTIONS

Precaution for Supplemental Restraint System (SRS) "AIR BAG" and "SEAT BELT PRE-TENSIONER"

INFOID:000000007152834

The Supplemental Restraint System such as "AIR BAG" and "SEAT BELT PRE-TENSIONER", used along with a front seat belt, helps to reduce the risk or severity of injury to the driver and front passenger for certain types of collision. This system includes seat belt switch inputs and dual stage front air bag modules. The SRS system uses the seat belt switches to determine the front air bag deployment, and may only deploy one front air bag, depending on the severity of a collision and whether the front occupants are belted or unbelted. Information necessary to service the system safely is included in the "SRS AIR BAG" and "SEAT BELT" of this Service Manual.

WARNING:

Always observe the following items for preventing accidental activation.

- To avoid rendering the SRS inoperative, which could increase the risk of personal injury or death in the event of a collision that would result in air bag inflation, all maintenance must be performed by an authorized NISSAN/INFINITI dealer.
- Improper maintenance, including incorrect removal and installation of the SRS, can lead to personal injury caused by unintentional activation of the system. For removal of Spiral Cable and Air Bag Module, see "SRS AIR BAG".
- Never use electrical test equipment on any circuit related to the SRS unless instructed to in this Service Manual. SRS wiring harnesses can be identified by yellow and/or orange harnesses or harness connectors.

PRECAUTIONS WHEN USING POWER TOOLS (AIR OR ELECTRIC) AND HAMMERS

WARNING:

Always observe the following items for preventing accidental activation.

- When working near the Air Bag Diagnosis Sensor Unit or other Air Bag System sensors with the ignition ON or engine running, never use air or electric power tools or strike near the sensor(s) with a hammer. Heavy vibration could activate the sensor(s) and deploy the air bag(s), possibly causing serious injury.
- When using air or electric power tools or hammers, always switch the ignition OFF, disconnect the battery, and wait at least 3 minutes before performing any service.

Precautions Necessary for Steering Wheel Rotation After Battery Disconnection

INFOID:000000007152835

CAUTION:

Comply with the following cautions to prevent any error and malfunction.

- Before removing and installing any control units, first turn the ignition switch to the LOCK position, then disconnect both battery cables.
- After finishing work, confirm that all control unit connectors are connected properly, then re-connect both battery cables.
- Always use CONSULT to perform self-diagnosis as a part of each function inspection after finishing work. If a DTC is detected, perform trouble diagnosis according to self-diagnosis results.

For vehicle with steering lock unit, if the battery is disconnected or discharged, the steering wheel will lock and cannot be turned.

If turning the steering wheel is required with the battery disconnected or discharged, follow the operation procedure below before starting the repair operation.

OPERATION PROCEDURE

1. Connect both battery cables.

NOTE:

Supply power using jumper cables if battery is discharged.

2. Turn the ignition switch to ACC position.
(At this time, the steering lock will be released.)
3. Disconnect both battery cables. The steering lock will remain released with both battery cables disconnected and the steering wheel can be turned.

A
B
C
D
E
F
G
H
I
J
K
L
N
O
P

PCS

PRECAUTIONS

[IPDM E/R]

< PRECAUTION >

4. Perform the necessary repair operation.
5. When the repair work is completed, re-connect both battery cables. With the brake pedal released, turn the ignition switch from ACC position to ON position, then to LOCK position. (The steering wheel will lock when the ignition switch is turned to LOCK position.)
6. Perform self-diagnosis check of all control units using CONSULT.

Precaution for Procedure without Cowl Top Cover

INFOID:000000007152836

When performing the procedure after removing cowl top cover, cover the lower end of windshield with urethane, etc to prevent damage to windshield.

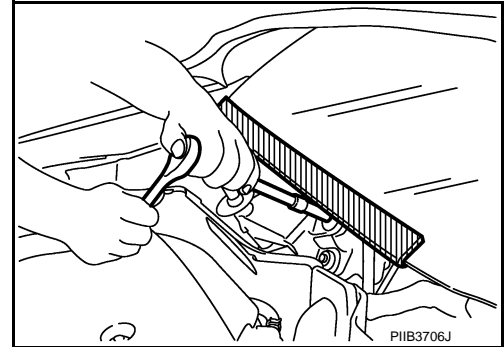

< SYSTEM DESCRIPTION >

SYSTEM DESCRIPTION

COMPONENT PARTS

IPDM E/R

IPDM E/R : Component Parts Location

INFOID:000000006887690

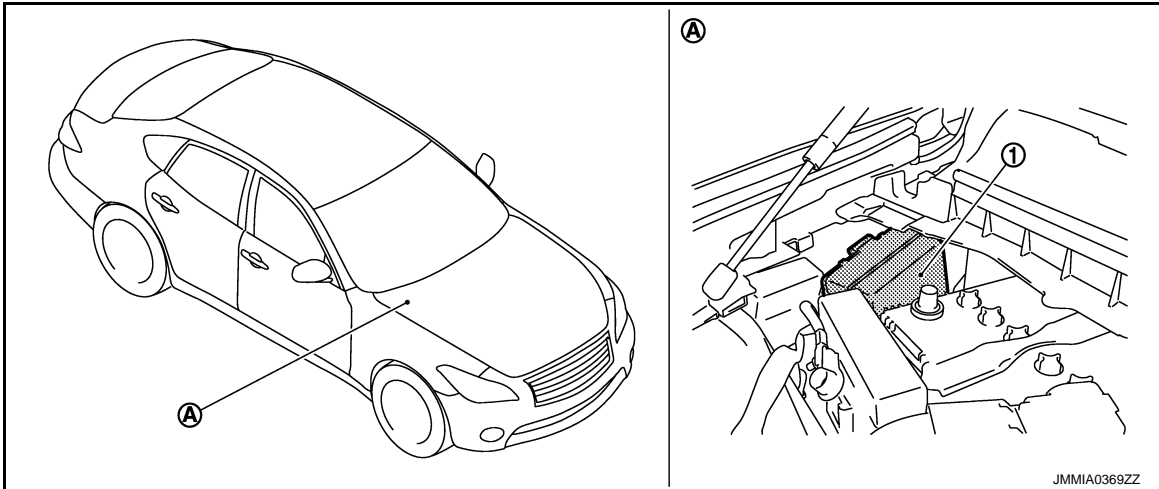

- 1. IPDM E/R
- A. Engine room dash panel (RH)

A
B
C
D
E
F
G
H
I
J
K
L

PCS

N
O
P

SYSTEM

RELAY CONTROL SYSTEM

RELAY CONTROL SYSTEM : System Diagram

INFOID:000000006887691

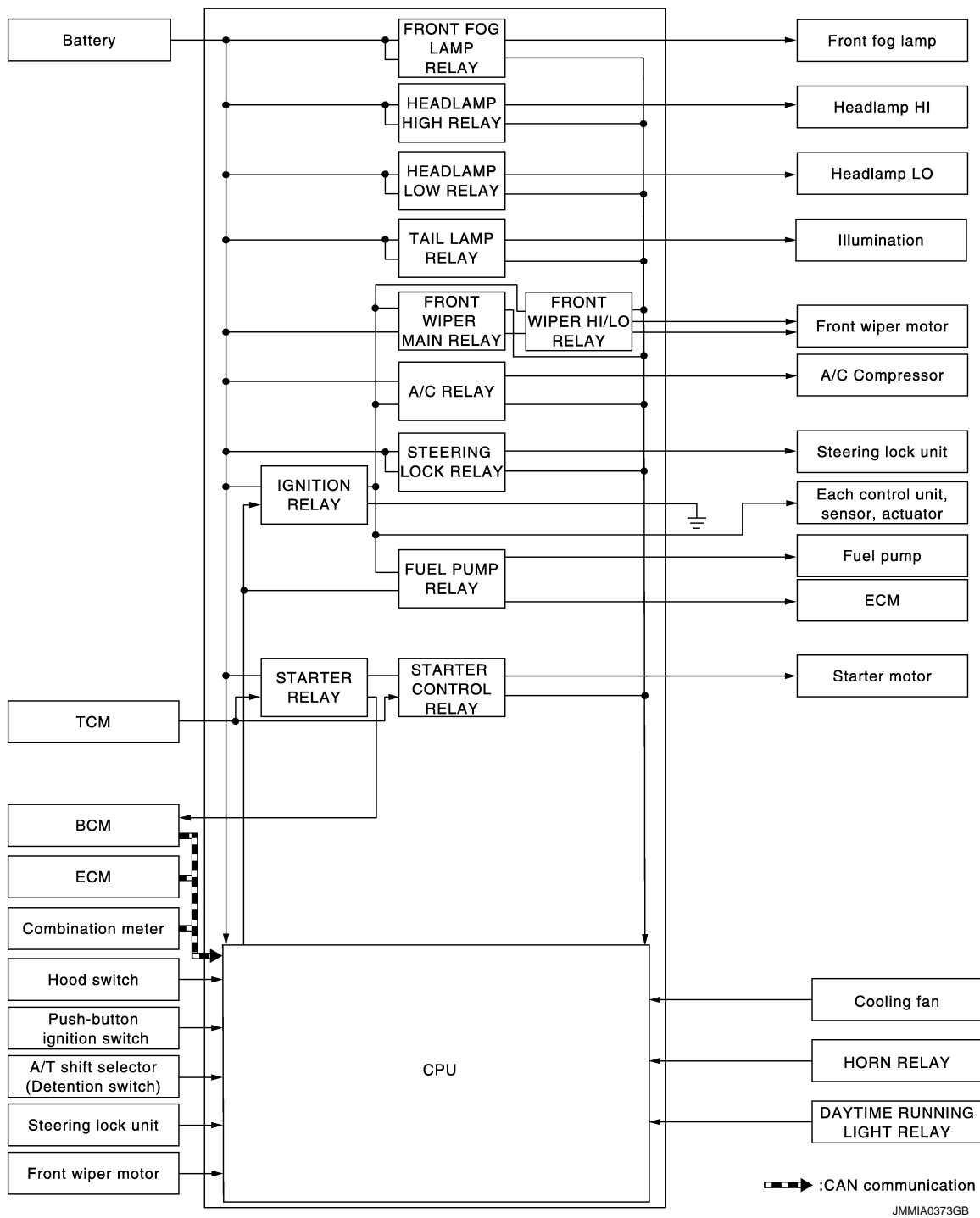

NOTE:

Steering lock relay and steering lock unit, as shown in the system diagram, are for models with steering lock unit only.

RELAY CONTROL SYSTEM : System Description

INFOID:000000006887692

IPDM E/R activates the internal control circuit to perform the relay ON-OFF control according to the input signals from various sensors and the request signals received from control units via CAN communication.

CAUTION:

SYSTEM

< SYSTEM DESCRIPTION >

[IPDM E/R]

To prevent damage to the parts, IPDM E/R integrated relays cannot be removed.

Control relay	Input/output	Transmit unit	Control part	Reference page
Headlamp low relay	<ul style="list-style-type: none"> Low beam request signal Daytime running light request signal 	BCM (CAN)	Headlamp (LO)	<ul style="list-style-type: none"> EXL-12 (Without DTRL) EXL-13 (With DTRL)
Headlamp high relay	High beam request signal	BCM (CAN)	Headlamp (HI)	
Front fog lamp relay	Front fog light request signal	BCM (CAN)	Front fog lamp	EXL-19
Tail lamp relay	Position light request signal	BCM (CAN)	<ul style="list-style-type: none"> Parking lamp License plate lamp Tail lamp Side marker lamp 	<ul style="list-style-type: none"> EXL-20 (Without DTRL) EXL-21 (With DTRL)
			Illumination	INL-6
<ul style="list-style-type: none"> Front wiper main relay Front wiper HI/LO relay 	Front wiper request signal	BCM (CAN)	Front wiper motor	WW-7
	Front wiper position signal	Front wiper motor		
<ul style="list-style-type: none"> Horn relay Vehicle security horn relay 	<ul style="list-style-type: none"> Theft warning horn request signal Horn reminder signal 	BCM (CAN)	<ul style="list-style-type: none"> Horn (high) Vehicle security horn 	SEC-18
<ul style="list-style-type: none"> Starter relay^{NOTE} Starter control relay 	Starter control relay signal	BCM (CAN)	Starter motor	<ul style="list-style-type: none"> SEC-10 SEC-10
	Steering lock unit condition signal	Steering lock unit		
	Starter relay control signal	TCM		
Steering lock relay*	Steering lock relay signal	BCM (CAN)	Steering lock unit*	SEC-10
	Steering lock unit condition signal	Steering lock unit		
	A/T shift selector (Detention switch) signal	A/T shift selector (Detention switch)		
A/C relay	A/C compressor request signal	ECM (CAN)	A/C compressor (magnet clutch)	<ul style="list-style-type: none"> HAC-22 (with Forest Air) HAC-30 (without Forest Air)
Ignition relay	Ignition switch ON signal	BCM (CAN)	Each control unit, sensor, actuator and relay (ignition power supply)	PCS-37
	Vehicle speed signal	Combination meter (CAN)		
	Push-button ignition switch signal	Push-button ignition switch		
Daytime running light relay	<ul style="list-style-type: none"> Daytime running light request signal Position light request signal 	BCM (CAN)	<ul style="list-style-type: none"> Headlamp (LO) Parking lamp License plate lamp Tail lamp Side marker lamp 	EXL-16

*: For models with steering lock unit only.

NOTE:

BCM controls the starter relay.

RELAY CONTROL SYSTEM : Fail-safe

INFOID:000000006887693

CAN COMMUNICATION CONTROL

When CAN communication with ECM and BCM is impossible, IPDM E/R performs fail-safe control. After CAN communication recovers normally, it also returns to normal control.

If No CAN Communication Is Available With ECM

SYSTEM

< SYSTEM DESCRIPTION >

[IPDM E/R]

Control part	Fail-safe operation
Cooling fan	<ul style="list-style-type: none"> • Outputs the pulse duty signal (PWM signal) 100% when the ignition switch is turned ON • Outputs the pulse duty signal (PWM signal) 0% when the ignition switch is turned OFF
A/C compressor	A/C relay OFF
Alternator	Outputs the power generation command signal (PWM signal) 0%

If No CAN Communication Is Available With BCM

Control part	Fail-safe operation
Headlamp	<ul style="list-style-type: none"> • Turns ON the headlamp low relay when the ignition switch is turned ON • Turns OFF the headlamp low relay when the ignition switch is turned OFF • Headlamp high relay OFF
<ul style="list-style-type: none"> • Parking lamp • License plate lamp • Illumination • Tail lamp • Side marker lamp 	<ul style="list-style-type: none"> • Turns ON the tail lamp relay and daytime running light relay when the ignition switch is turned ON • Turns OFF the tail lamp relay and daytime running light relay when the ignition switch is turned OFF
Front wiper motor	<ul style="list-style-type: none"> • The status just before activation of fail-safe control is maintained until the ignition switch is turned OFF while the front wiper is operating at LO or HI speed. • The wiper is operated at LO speed until the ignition switch is turned OFF if the fail-safe control is activated while the front wiper is set in the AUTO mode and the front wiper motor is operating. • Returns automatically wiper to stop position when ignition switch is turned ON if fail-safe control is activated while front wiper motor is operated and wiper stop in the other than stop position.
Front fog lamp	Front fog lamp relay OFF
Horn	Horn OFF
Ignition relay	The status just before activation of fail-safe is maintained.
Starter motor	Starter control relay OFF
Steering lock unit*	Steering lock relay OFF

*: For models with steering lock unit

IGNITION RELAY MALFUNCTION DETECTION FUNCTION

- IPDM E/R monitors the voltage at the contact circuit and excitation coil circuit of the ignition relay inside it.
- IPDM E/R judges the ignition relay error if the voltage differs between the contact circuit and the excitation coil circuit.
- If the ignition relay cannot turn OFF due to contact seizure, it activates the tail lamp relay and daytime running light relay for 10 minutes to alert the user to the ignition relay malfunction when the ignition switch is turned OFF.

Voltage judgment		IPDM E/R judgment	Operation
Ignition relay contact side	Ignition relay excitation coil side		
ON	ON	Ignition relay ON normal	—
OFF	OFF	Ignition relay OFF normal	—
ON	OFF	Ignition relay ON stuck	<ul style="list-style-type: none"> • Detects DTC "B2098: IGN RELAY ON" • Turns ON the tail lamp relay and daytime running light relay for 10 minutes
OFF	ON	Ignition relay OFF stuck	Detects DTC "B2099: IGN RELAY OFF"

FRONT WIPER PROTECTION FUNCTION

IPDM E/R detects front wiper stop position by a front wiper stop position signal.

SYSTEM

< SYSTEM DESCRIPTION >

[IPDM E/R]

When a front wiper stop position signal is in the conditions listed below, IPDM E/R stops power supply to wiper after repeating a front wiper 10 seconds activation and 20 seconds stop five times.

Ignition switch	Front wiper switch	Front wiper stop position signal
ON	OFF	The front wiper stop position signal (stop position) cannot be input for 10 seconds.
	ON	The front wiper stop position signal does not change for 10 seconds.

NOTE:

This operation status can be confirmed on the IPDM E/R "Data Monitor" that displays "BLOCK" for the item "WIP PROT" while the wiper is stopped.

STARTER MOTOR PROTECTION FUNCTION

IPDM E/R turns OFF the starter control relay to protect the starter motor when the starter control relay remains active for 90 seconds.

POWER CONTROL SYSTEM

POWER CONTROL SYSTEM : System Diagram

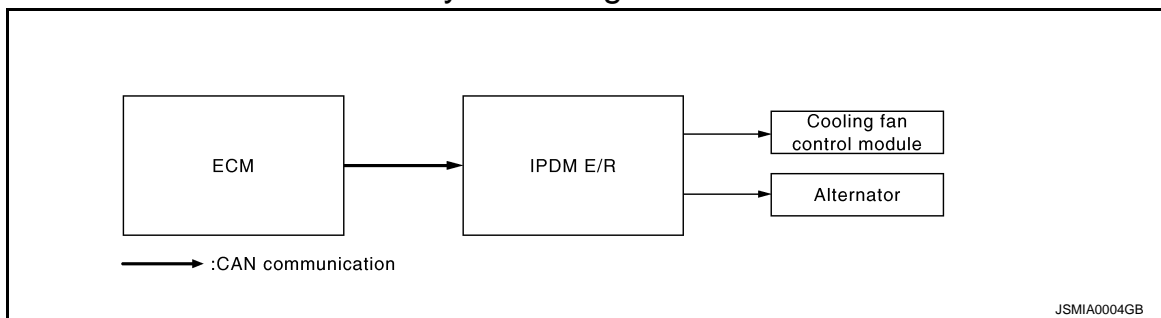

POWER CONTROL SYSTEM : System Description

INFOID:0000000006887695

COOLING FAN CONTROL

IPDM E/R outputs pulse duty signal (PWM signal) to the cooling fan control module according to the status of the cooling fan speed request signal received from ECM via CAN communication. Refer to [EC-64, "COOLING FAN CONTROL : System Diagram"](#) (VQ37VHR) or [EC-1017, "COOLING FAN CONTROL : System Diagram"](#) (VK56VD).

ALTERNATOR CONTROL

IPDM E/R outputs power generation command signal (PWM signal) to the alternator according to the status of the power generation command value signal received from ECM via CAN communication. Refer to [CHG-8, "POWER GENERATION VOLTAGE VARIABLE CONTROL SYSTEM : System Diagram"](#).

SIGNAL BUFFER SYSTEM

SIGNAL BUFFER SYSTEM : System Diagram

INFOID:0000000006887696

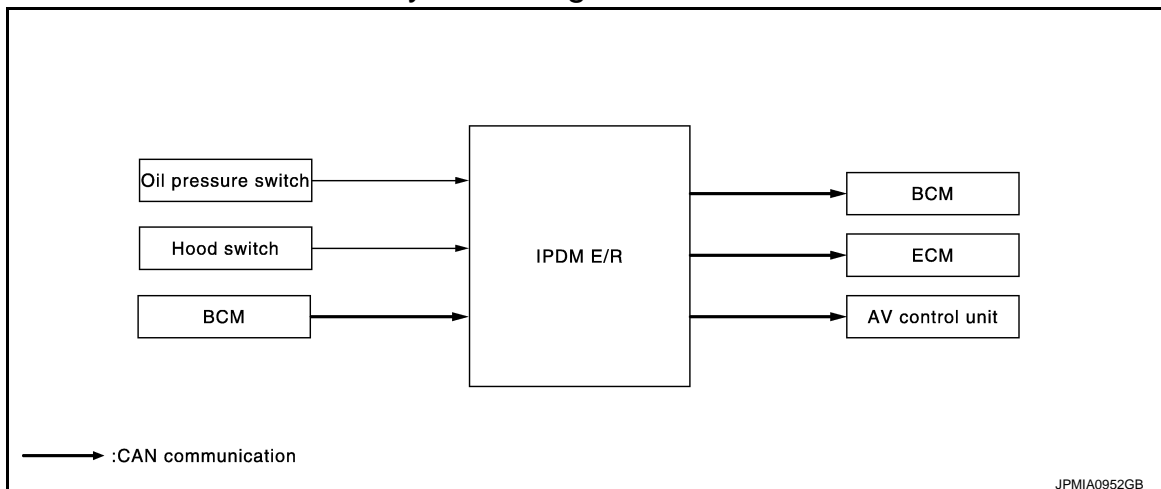

A
B
C
D
E
F
G
H
I
J
K
L

PCS

N
O
P

SIGNAL BUFFER SYSTEM : System Description

INFOID:000000006887697

- IPDM E/R reads the status of the oil pressure switch and transmits the oil pressure switch signal to BCM via CAN communication (only for models with VQ37VHR engine). Refer to [MWI-15. "OIL PRESSURE WARNING LAMP : System Diagram"](#).
- IPDM E/R reads the status of the hood switch and transmits the hood switch signal to BCM via CAN communication. Refer to [SEC-10. "Hood Switch"](#).
- IPDM E/R receives the rear window defogger control signal from BCM via CAN communication and transmits it to ECM and AV control unit via CAN communication. Refer to [DEF-5. "System Diagram"](#).

POWER CONSUMPTION CONTROL SYSTEM

POWER CONSUMPTION CONTROL SYSTEM : System Diagram

INFOID:000000007153254

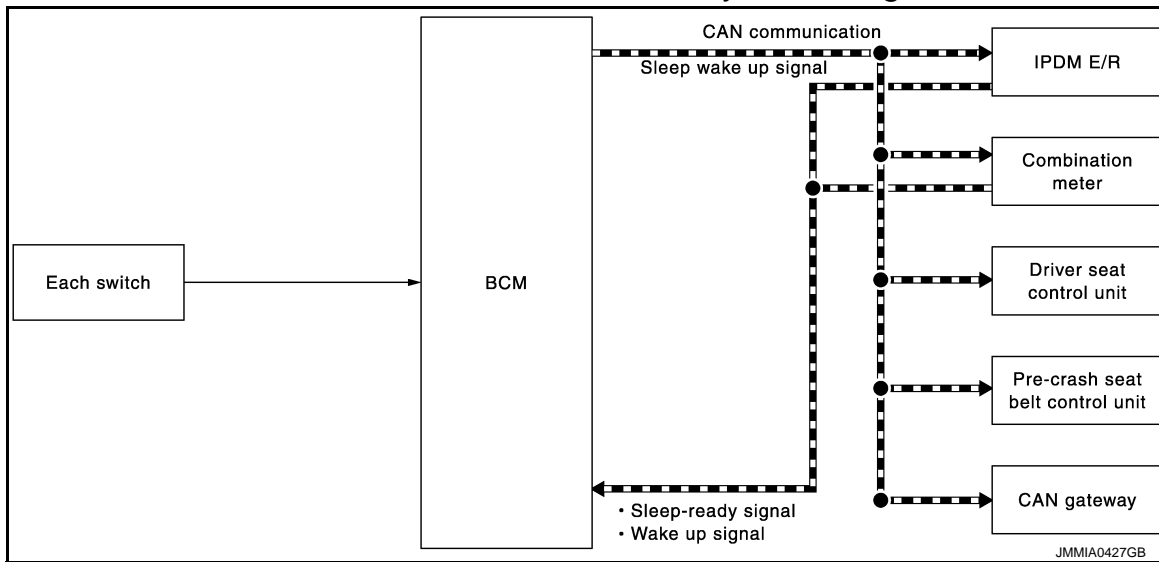

POWER CONSUMPTION CONTROL SYSTEM : System Description

INFOID:000000006887699

OUTLINE

- IPDM E/R incorporates a power consumption control function that reduces the power consumption according to the vehicle status.
- IPDM E/R changes its status (control mode) with the sleep wake up signal received from BCM via CAN communication.

Normal mode (wake-up)

- CAN communication is normally performed with other control units.
- Individual unit control by IPDM E/R is normally performed.

Low power consumption mode (sleep)

- Low power consumption control is active.
- CAN transmission is stopped.

SLEEP MODE ACTIVATION

- IPDM E/R judges that the sleep-ready conditions are fulfilled when the ignition switch is OFF and none of the conditions below are present. Then it transmits a sleep-ready signal (ready) to BCM via CAN communication.
 - Outputting signals to actuators
 - Switches or relays operating
 - Hood switch status is kept 50 ms or less.
 - Output requests are being received from control units via CAN communication.
- IPDM E/R stops CAN communication and enters the low power consumption mode when it receives a sleep wake up signal (sleep) from BCM and the sleep-ready conditions are fulfilled.

WAKE-UP OPERATION

SYSTEM

[IPDM E/R]

< SYSTEM DESCRIPTION >

- IPDM E/R changes from the low power consumption mode to the normal mode when it receives a sleep wake-up signal (wake up) from BCM or any of the following conditions is fulfilled. In addition, it transmits a sleep-ready signal (not-ready) to BCM via CAN communication to report the CAN communication start.
- Ignition switch ON
- The hood switch status changes.
- An output request is received from a control unit via CAN communication.

A

B

C

D

E

F

G

H

I

J

K

L

PCS

N

O

P

DIAGNOSIS SYSTEM (IPDM E/R)

Diagnosis Description

INFOID:000000006887700

AUTO ACTIVE TEST

Description

In auto active test, the IPDM E/R sends a drive signal to the following systems to check their operation.

- Oil pressure warning lamp (only for models with VQ37VHR engine)
- Front wiper (LO, HI)
- Parking lamp
- License plate lamp
- Tail lamp
- Side marker lamp
- Front fog lamp
- Headlamp (LO, HI)
- A/C compressor (magnet clutch)
- Cooling fan (cooling fan control module)

Operation Procedure

CAUTION:

Wiper arm interferes with hood when wiper is operated while wiper arm is in the raised position. Always perform auto active test without setting wiper arm in the raised position. Always pour water on front windshield glass in advance to auto active test so that damage on front windshield glass surface is prevented.

NOTE:

Never perform auto active test in the following condition.

- Engine is running
- CONSULT is connected

1. Turn the ignition switch OFF.
2. Turn the ignition switch ON, and within 20 seconds, press the front door switch (driver side) 10 times. Then turn the ignition switch OFF.

NOTE:

- Close passenger door.
- Within 5 seconds after ignition switch is turned to the ON position and when driver door switch is pressed 6 times or more within 4 seconds, self-diagnosis function for BOSE amp. activates and speaker sounds. After waiting for 5 seconds or more after ignition switch is turned to the ON position and when driver door switch is operated, self-diagnosis function for BOSE amp. does not activate.

3. Turn the ignition switch ON within 10 seconds. After that the horn sounds once and the auto active test starts.

NOTE:

Engine starts when ignition switch is turned ON while brake pedal is depressed.

4. The oil pressure warning lamp starts blinking when the auto active test starts.
5. After a series of the following operations is repeated 3 times, auto active test is completed.

NOTE:

- When auto active test has to be cancelled halfway through test, turn the ignition switch OFF.
- When auto active test is not activated, door switch may be the cause. Check door switch. Refer to [DLK-60, "Component Function Check"](#).

Inspection in Auto Active Test

When auto active test is actuated, the following 6 steps are repeated 3 times.

Operation sequence	Inspection location	Operation
1	Oil pressure warning lamp (only for models with VQ37VHR engine)	Blinks continuously during operation of auto active test
2	Front wiper motor	LO for 5 seconds → HI for 5 seconds

DIAGNOSIS SYSTEM (IPDM E/R)

< SYSTEM DESCRIPTION >

[IPDM E/R]

Operation sequence	Inspection location	Operation
3	<ul style="list-style-type: none"> • Parking lamp • License plate lamp • Tail lamp • Side marker lamp • Front fog lamp 	10 seconds
4	Headlamp	<ul style="list-style-type: none"> • LO 10 seconds • HI ON ⇔ OFF 5 times
5	A/C compressor (magnet clutch)	ON ⇔ OFF 5 times
6	Cooling fan	MID for 5 seconds → HI for 5 seconds

*: Outputs duty ratio of 50% for 5 seconds → duty ratio of 100% for 5 seconds on the cooling fan control module.

Concept of auto active test

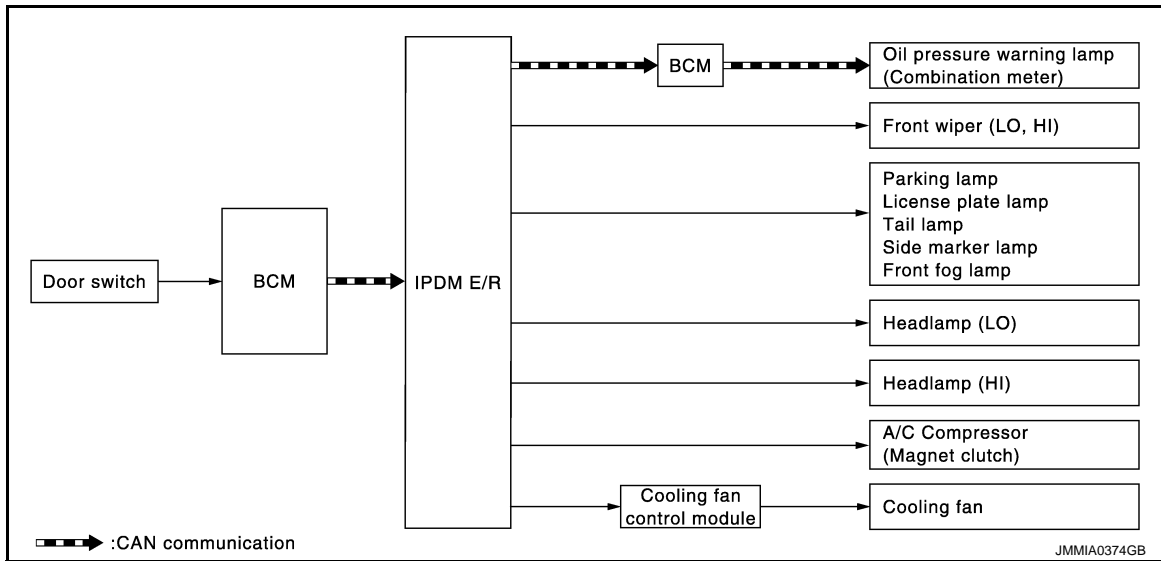

- IPDM E/R starts the auto active test with the door switch signals transmitted by BCM via CAN communication. Therefore, the CAN communication line between IPDM E/R and BCM is considered normal if the auto active test starts successfully.
- The auto active test facilitates troubleshooting if any systems controlled by IPDM E/R cannot be operated.

Diagnosis chart in auto active test

Symptom	Inspection contents		Possible cause
Any of the following components do not operate <ul style="list-style-type: none"> • Parking lamp • License plate lamp • Tail lamp • Side marker lamp • Front fog lamp • Headlamp (HI, LO) • Front wiper motor 	Perform auto active test. Does the applicable system operate?	YES	BCM signal input circuit
		NO	<ul style="list-style-type: none"> • Lamp or motor • Lamp or motor ground circuit • Harness or connector between IPDM E/R and applicable system • IPDM E/R
A/C compressor does not operate	Perform auto active test. Does the magnet clutch operate?	YES	<ul style="list-style-type: none"> • Combination meter signal input circuit • CAN communication signal between Combination meter and ECM • CAN communication signal between ECM and IPDM E/R
		NO	<ul style="list-style-type: none"> • Magnet clutch • Harness or connector between IPDM E/R and magnet clutch • IPDM E/R

DIAGNOSIS SYSTEM (IPDM E/R)

< SYSTEM DESCRIPTION >

[IPDM E/R]

Symptom	Inspection contents	Possible cause
Oil pressure warning lamp does not operate (only for models with VQ37VHR engine)	Perform auto active test. Does the oil pressure warning lamp blink?	YES <ul style="list-style-type: none"> • Harness or connector between IPDM E/R and oil pressure switch • Oil pressure switch • IPDM E/R
		NO <ul style="list-style-type: none"> • CAN communication signal between IPDM E/R and BCM • CAN communication signal between BCM and Combination meter • Combination meter
Cooling fan does not operate	Perform auto active test. Does the cooling fan operate?	YES <ul style="list-style-type: none"> • ECM signal input circuit • CAN communication signal between ECM and IPDM E/R
		NO <ul style="list-style-type: none"> • Cooling fan • Harness or connector between cooling fan and cooling fan control module • Cooling fan control module • Harness or connector between IPDM E/R and cooling fan control module • Cooling fan relay • Harness or connector between IPDM E/R and cooling fan relay • IPDM E/R

CONSULT Function (IPDM E/R)

INFOID:000000006887701

APPLICATION ITEM

CONSULT performs the following functions via CAN communication with IPDM E/R.

Diagnosis mode	Description
Ecu Identification	Allows confirmation of IPDM E/R part number.
Self Diagnostic Result	Displays the diagnosis results judged by IPDM E/R.
Data Monitor	Displays the real-time input/output data from IPDM E/R input/output data.
Active Test	IPDM E/R can provide a drive signal to electronic components to check their operations.
CAN Diag Support Monitor	The results of transmit/receive diagnosis of CAN communication can be read.

SELF DIAGNOSTIC RESULT

Refer to [PCS-25. "DTC Index"](#).

DATA MONITOR

Monitor item

Monitor Item [Unit]	MAIN SIGNALS	Description
RAD FAN REQ [%]	×	Displays the value of the cooling fan speed signal received from ECM via CAN communication.
AC COMP REQ [Off/On]	×	Displays the status of the A/C compressor request signal received from ECM via CAN communication.
TAIL&CLR REQ [Off/On]	×	Displays the status of the position light request signal received from BCM via CAN communication.
HL LO REQ [Off/On]	×	Displays the status of the low beam request signal received from BCM via CAN communication.
HL HI REQ [Off/On]	×	Displays the status of the high beam request signal received from BCM via CAN communication.
FR FOG REQ [Off/On]	×	Displays the status of the front fog light request signal received from BCM via CAN communication.

DIAGNOSIS SYSTEM (IPDM E/R)

< SYSTEM DESCRIPTION >

[IPDM E/R]

Monitor Item [Unit]	MAIN SIG- NALS	Description
FR WIP REQ [Stop/1LOW/Low/Hi]	×	Displays the status of the front wiper request signal received from BCM via CAN communication.
WIP AUTO STOP [STOP P/ACT P]	×	Displays the status of the front wiper stop position signal judged by IPDM E/R.
WIP PROT [Off/BLOCK]	×	Displays the status of the front wiper fail-safe operation judged by IPDM E/R.
IGN RLY1 -REQ [Off/On]		Displays the status of the ignition switch ON signal received from BCM via CAN communication.
IGN RLY [Off/On]	×	Displays the status of the ignition relay judged by IPDM E/R.
PUSH SW [Off/On]		Displays the status of the push-button ignition switch judged by IPDM E/R.
INTER/NP SW [Off/On]		Displays the status of the shift position judged by IPDM E/R.
ST RLY CONT [Off/On]		Displays the status of the starter relay status signal received from BCM via CAN communication.
IHBT RLY -REQ [Off/On]		Displays the status of the starter control relay signal received from BCM via CAN communication.
ST/INHI RLY [Off/ ST /INHI/UNKWN]		Displays the status of the starter relay and starter control relay judged by IPDM E/R.
DETENT SW [Off/On]		Displays the status of the A/T shift selector (detention switch) judged by IPDM E/R.
S/L RLY -REQ [Off/On]		Displays the status of the steering lock relay request received from BCM via CAN communication. NOTE: For models without steering lock unit, this item is not monitored.
S/L STATE [LOCK/UNLOCK/UNKWN]		Displays the status of the steering lock judged by IPDM E/R. NOTE: For models without steering lock unit, this item is not monitored.
DTRL REQ [Off/On]		Displays the status of the daytime running light request signal received from BCM via CAN communication. NOTE: This item is monitored only on the vehicle with daytime running light system.
OIL P SW [Open/Close]		Displays the status of the oil pressure switch judged by IPDM E/R. NOTE: This item is monitored only on the vehicle with VQ37VHR engine models.
HOOD SW [Off/On]		Displays the status of the hood switch judged by IPDM E/R.
HL WASHER REQ [Off/On]		NOTE: This item is indicated, but not monitored.
THFT HRN REQ [Off/On]		Displays the status of the theft warning horn request signal received from BCM via CAN communication.
HORN CHIRP [Off/On]		Displays the status of the horn reminder signal received from BCM via CAN communication.
CRNRNG LMP REQ [Off/On]		NOTE: This item is indicated, but not monitored.

ACTIVE TEST

Test item

A
B
C
D
E
F
G
H
I
J
K
L
PCS
N
O
P

DIAGNOSIS SYSTEM (IPDM E/R)

< SYSTEM DESCRIPTION >

[IPDM E/R]

Test item	Operation	Description
CORNERING LAMP	Off	NOTE: This item is indicated, but cannot be tested.
	LH	
	RH	
HORN	On	Operates horn relay for 20 ms.
FRONT WIPER	Off	OFF
	Lo	Operates the front wiper relay.
	Hi	Operates the front wiper relay and front wiper high relay.
MOTOR FAN	1	OFF
	2	Transmits 50% pulse duty signal (PWM signal) to the cooling fan control module.
	3	Transmits 75% pulse duty signal (PWM signal) to the cooling fan control module.
	4	Transmits 100% pulse duty signal (PWM signal) to the cooling fan control module.
HEAD LAMP WASHER	On	NOTE: This item is indicated, but cannot be tested.
EXTERNAL LAMPS	Off	OFF
	TAIL	Operates the tail lamp relay and the daytime running light relay.
	Lo	Operates the headlamp low relay.
	Hi	Operates the headlamp low relay and ON/OFF the headlamp high relay at 1 second intervals.
	Fog	Operates the front fog lamp relay.

ECU DIAGNOSIS INFORMATION

IPDM E/R

Reference Value

INFOID:0000000006887702

VALUES ON THE DIAGNOSIS TOOL

Monitor Item	Condition		Value/Status
RAD FAN REQ	Engine idle speed	Changes depending on engine coolant temperature, air conditioner operation status, vehicle speed, etc.	0 – 100 %
AC COMP REQ	Engine running	A/C switch OFF	Off
		A/C switch ON (compressor is operating)	On
TAIL&CLR REQ	Lighting switch OFF		Off
	<ul style="list-style-type: none"> Lighting switch 1ST, 2ND or AUTO (light is illuminated) Daytime running light system is operated 		On
HL LO REQ	Lighting switch OFF		Off
	Lighting switch 2ND or AUTO (light is illuminated)		On
	Daytime running light system is operated		
HL HI REQ	Lighting switch 2ND or AUTO (light is illuminated)	Lighting switch other than HI and PASS	Off
		Lighting switch HI or PASS	On
FR FOG REQ	Lighting switch 2ND or AUTO (light is illuminated)	Front fog lamp switch OFF	Off
		Lighting switch HI or PASS	
		Front fog lamp switch ON	On
FR WIP REQ	Ignition switch ON	Front wiper switch OFF	Stop
		Front wiper switch AUTO	1LOW
		Front wiper switch LO	Low
		Front wiper switch HI	Hi
WIP AUTO STOP	Ignition switch ON	Front wiper stop position	STOP P
		Any position other than front wiper stop position	ACT P
WIP PROT	Ignition switch ON	Front wiper operates normally	Off
		Front wiper stops at fail-safe operation	BLOCK
IGN RLY1 -REQ	Ignition switch OFF or ACC		Off
	Ignition switch ON		On
IGN RLY	Ignition switch OFF or ACC		Off
	Ignition switch ON		On
PUSH SW	Release the push-button ignition switch		Off
	Press the push-button ignition switch		On
INTER/NP SW	Ignition switch ON	Selector lever in any position other than P or N	Off
		Selector lever in P or N position	On
ST RLY CONT	Ignition switch ON		Off
	At engine cranking		On
IHBT RLY -REQ	Ignition switch ON		Off
	At engine cranking		On

A

B

C

D

E

F

G

H

I

J

K

L

PCS

N

O

P

IPDM E/R

< ECU DIAGNOSIS INFORMATION >

[IPDM E/R]

Monitor Item	Condition	Value/Status
ST/INHI RLY	Ignition switch ON	Off
	At engine cranking	INHI → ST
	The status of starter relay or starter control relay cannot be recognized by the battery voltage malfunction, etc. when the starter relay is ON and the starter control relay is OFF	UNKWN
DETENT SW	Ignition switch ON <ul style="list-style-type: none"> • Press the selector button with selector lever in P position • Selector lever in any position other than P 	Off
	Release the selector button with selector lever in P position	On
S/L RLY -REQ NOTE: For models without steering lock unit, this item is not monitored.	None of the conditions below are present	Off
	<ul style="list-style-type: none"> • Open the driver door after the ignition switch is turned OFF (for a few seconds) • Press the push-button ignition switch when the steering lock is activated 	On
S/L STATE NOTE: For models without steering lock unit, this item is not monitored.	Steering lock is activated	LOCK
	Steering lock is deactivated	UNLOCK
	[DTC: B210A] is detected	UNKWN
DTRL REQ	Daytime running light system is not operated	Off
	Any of the condition below <ul style="list-style-type: none"> • Daytime running light system is operated • Light switch 1ST, 2ND or AUTO (light is illuminated) 	On
OIL P SW	Ignition switch OFF or ACC	Open
	Ignition switch ON (engine running)	
	Ignition switch ON (engine stopped)	Close
HOOD SW	Close the hood	Off
	Open the hood	On
HL WASHER REQ	NOTE: This item is indicated, but not monitored.	Off
THFT HRN REQ	Not operation	Off
	<ul style="list-style-type: none"> • Panic alarm is activated • Theft warning alarm is activated 	On
HORN CHIRP	Not operation	Off
	Door locking with Intelligent Key (horn chirp mode)	On
CRNRNG LMP REQ	NOTE: This item is indicated, but not monitored.	Off

TERMINAL LAYOUT

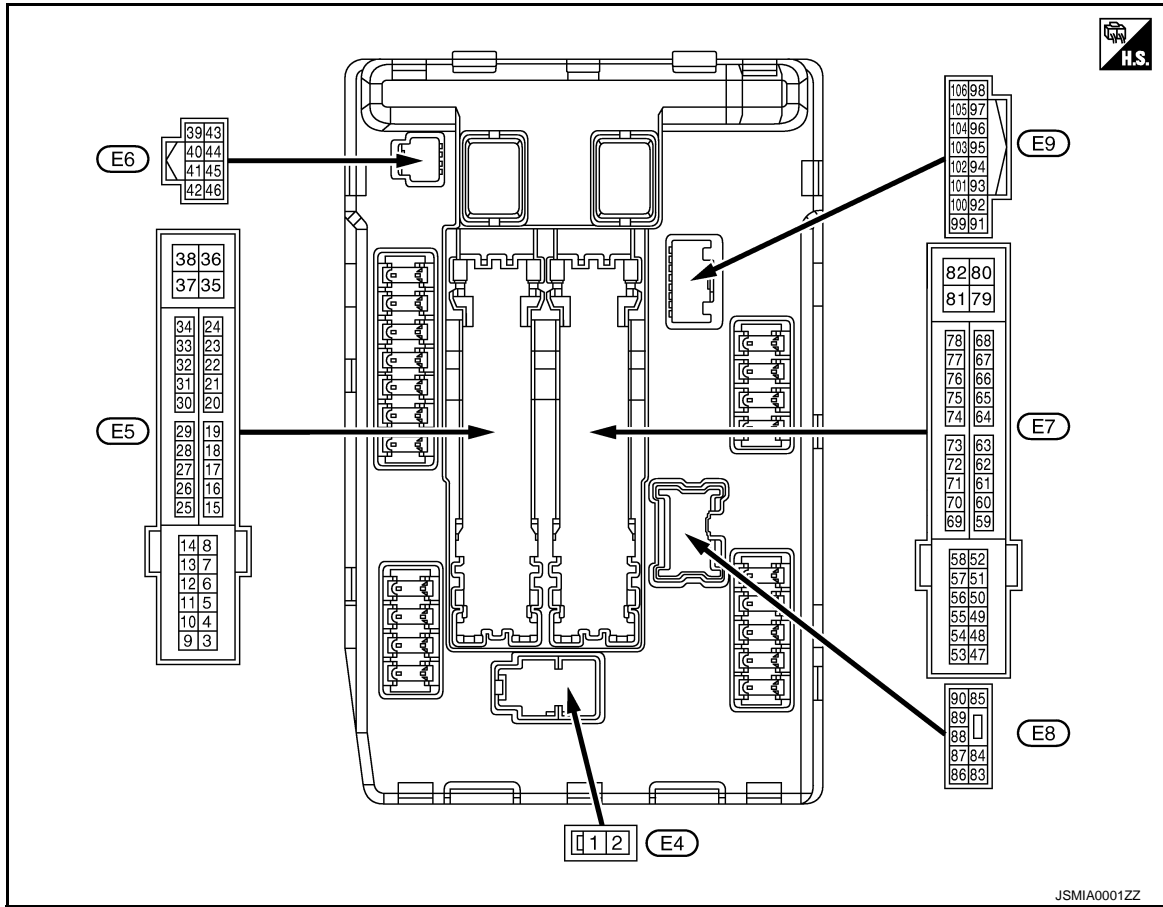

PHYSICAL VALUES

Terminal No. (Wire color)		Description		Condition	Value (Approx.)
+	-	Signal name	Input/ Output		
1 (W)	Ground	Battery power supply	Input	Ignition switch OFF	Battery voltage
2 (L)	Ground	Battery power supply	Input	Ignition switch OFF	Battery voltage
4 (W)	Ground	ECM relay power supply	Output	Ignition switch OFF (More than a few seconds after turning ignition switch OFF)	0 V
				<ul style="list-style-type: none"> Ignition switch ON Ignition switch OFF (For a few seconds after turning ignition switch OFF) 	Battery voltage
5 (P)	Ground	ECM relay power supply	Output	Ignition switch OFF (More than a few seconds after turning ignition switch OFF)	0 V
				<ul style="list-style-type: none"> Ignition switch ON Ignition switch OFF (For a few seconds after turning ignition switch OFF) 	Battery voltage

A
B
C
D
E
F
G
H
I
J
K
L
PCS
N
O
P

IPDM E/R

< ECU DIAGNOSIS INFORMATION >

[IPDM E/R]

Terminal No. (Wire color)		Description		Condition	Value (Approx.)
+	-	Signal name	Input/ Output		
6 (R)	Ground	ECM relay power supply	Output	Ignition switch OFF (More than a few seconds after turning ignition switch OFF)	0 V
				<ul style="list-style-type: none"> • Ignition switch ON • Ignition switch OFF (For a few seconds after turning ignition switch OFF) 	Battery voltage
7 (Y)	Ground	Throttle control motor relay power supply	Output	Ignition switch OFF (More than a few seconds after turning ignition switch OFF)	0 V
				<ul style="list-style-type: none"> • Ignition switch ON • Ignition switch OFF (For a few seconds after turning ignition switch OFF) 	Battery voltage
8 (L)	Ground	A/C relay power supply	Output	Engine running	A/C switch OFF
					A/C switch ON (A/C compressor is operating)
10 (V)	Ground	ECM power supply	Output	Ignition switch OFF	Battery voltage
11 (B)	Ground	Ground	—	Ignition switch ON	0 V
12 (G)	Ground	Ignition relay power supply	Output	Ignition switch OFF or ACC	0 V
				Ignition switch ON	Battery voltage
13 (GR)	Ground	Fuel pump relay power supply	Output	Approximately 1 second or more after turning the ignition switch ON	0 V
				<ul style="list-style-type: none"> • Approximately 1 second after turning the ignition switch ON • Engine running 	Battery voltage
16 (V)	Ground	Front wiper stop position	Input	Ignition switch ON	Front wiper stop position
					Any position other than front wiper stop position
18 (Y)	Ground	Ignition relay monitor	Input	Ignition switch OFF or ACC	Battery voltage
				Ignition switch ON	0 V

IPDM E/R

< ECU DIAGNOSIS INFORMATION >

[IPDM E/R]

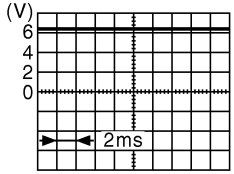
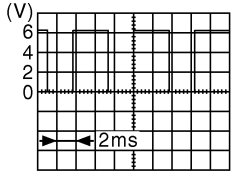
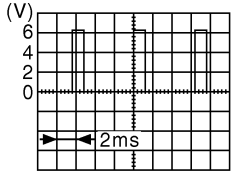
Terminal No. (Wire color)		Description		Condition	Value (Approx.)
+	-	Signal name	Input/ Output		
22 (BR)	Ground	Power generation command signal	Output	Ignition switch ON	 6.3 V
				40% is set on "ACTIVE TEST", "ALTERNATOR DUTY" of "ENGINE"	 3.8 V
				80% is set on "ACTIVE TEST", "ALTERNATOR DUTY" of "ENGINE"	 1.4 V
23 (SB)	Ground	Daytime running light relay control	Output	<ul style="list-style-type: none"> • Parking lamp • License plate lamp • Tail lamp Turned OFF	Battery voltage
				Turned ON	0 V
24 (O)	Ground	Hood switch	Input	Close the hood	12 V
				Open the hood	0 V
25 (LG)	Ground	Ignition relay power supply	Output	Ignition switch OFF or ACC	0 V
				Ignition switch ON	Battery voltage
30 (BR)	Ground	Push-button ignition switch	Input	Press the push-button ignition switch	0 V
				Release the push-button ignition switch	12 V
31 (W)	Ground	Starter relay control	Input	Ignition switch ON	Selector lever in any position other than P or N 0 V
				Selector lever P or N	12 V
32*2 (L)	Ground	Steering lock unit condition-1	Input	Steering lock is activated	0 V
				Steering lock is deactivated	12 V
34*2 (P)	Ground	Steering lock unit condition-2	Input	Steering lock is activated	12 V
				Steering lock is deactivated	0 V
36 (GR)	Ground	Battery power supply	Input	Ignition switch OFF	Battery voltage
39 (P)	—	CAN-L	Input/ Output	—	—
40 (L)	—	CAN-H	Input/ Output	—	—
41 (B)	Ground	Ground	—	Ignition switch ON	0 V

A
B
C
D
E
F
G
H
I
J
K
L
PCS
N
O
P

IPDM E/R

< ECU DIAGNOSIS INFORMATION >

[IPDM E/R]

Terminal No. (Wire color)		Description		Condition	Value (Approx.)
		Signal name	Input/ Output		
+	-				
42 (V)	Ground	Cooling fan relay 1 control	Input	Ignition switch OFF or ACC	0 V
				Ignition switch ON	0.7 V
43 (SB)	Ground	A/T shift selector (Detention switch)	Input	Ignition switch ON	12 V
				Release the selector button (selector lever P)	0 V
44 (GR)	Ground	Horn relay control	Input	The horn is deactivated	Battery voltage
				The horn is activated	0 V
45 (G)	Ground	Vehicle security horn relay control	Input	The horn is deactivated	Battery voltage
				The horn is activated	0 V
46 (BR)	Ground	Starter relay control	Input	Ignition switch ON	0 V
				Selector lever in any position other than P or N	12 V
49*2 (BR)	Ground	Steering lock unit power supply	Output	Ignition switch OFF	A few seconds after opening the driver door
				Ignition switch LOCK	Press the push-button ignition switch
				Ignition switch ACC or ON	
51 (O)	Ground	Ignition relay power supply	Output	Ignition switch OFF or ACC	0 V
				Ignition switch ON	Battery voltage
52 (G)	Ground	Ignition relay power supply	Output	Ignition switch OFF or ACC	0 V
				Ignition switch ON	Battery voltage
53 (L)	Ground	Front wiper HI (ground)	Output	Ignition switch ON	Front wiper switch OFF or HI
54 (P)	Ground	Front wiper LO	Output	Ignition switch ON	Front wiper switch OFF
				Front wiper switch LO	Battery voltage
55 (R)	Ground	Illumination	Output	Lighting switch OFF	0 V
				Lighting switch 1ST	Battery voltage
56 (GR)	Ground	Ignition relay power supply	Output	Ignition switch OFF or ACC	0 V
				Ignition switch ON	Battery voltage
57 (V)	Ground	Ignition relay power supply	Output	Ignition switch OFF or ACC	0 V
				Ignition switch ON	Battery voltage
58 (BR)	Ground	Ignition relay power supply	Output	Ignition switch OFF or ACC	0 V
				Ignition switch ON	Battery voltage
70 (LG)	Ground	ECM relay control	Output	Ignition switch OFF (More than a few seconds after turning ignition switch OFF)	Battery voltage
				Ignition switch ON Ignition switch OFF (For a few seconds after turning ignition switch OFF)	0 – 1.5 V

IPDM E/R

< ECU DIAGNOSIS INFORMATION >

[IPDM E/R]

Terminal No. (Wire color)		Description		Condition		Value (Approx.)	
+	-	Signal name	Input/ Output				
71 (O)	Ground	Throttle control motor relay control	Output	Ignition switch ON → OFF		0 – 1.0 V ↓ Battery voltage ↓ 0 V	A
				Ignition switch ON		0 – 1.0 V	B
73 (G)	Ground	Ignition relay power supply	Output	Ignition switch OFF or ACC		0 V	C
				Ignition switch ON		Battery voltage	D
74 (R)	Ground	Ignition relay power supply	Output	Ignition switch OFF or ACC		0 V	E
				Ignition switch ON		Battery voltage	F
75*1 (Y)	Ground	Oil pressure switch	Input	Ignition switch ON	Engine stopped	0 V	G
					Engine running	12 V	H
77 (B)	Ground	Fuel pump relay control	Output	<ul style="list-style-type: none"> • Approximately 1 second after turning the ignition switch ON • Engine running 		0 – 1.0 V	I
				Approximately 1 second or more after turning the ignition switch ON		Battery voltage	J
80 (W)	Ground	Starter motor	Output	At engine cranking		Battery voltage	K
83 (R)	Ground	Headlamp LO (RH)	Output	Lighting switch OFF		0 V	L
				Lighting switch 2ND or AUTO (light is illumi- nated)		Battery voltage	M
				Daytime running light operated			N
84 (W)	Ground	Headlamp LO (LH)	Output	Lighting switch OFF		0 V	O
				Lighting switch 2ND or AUTO (light is illumi- nated)		Battery voltage	P
				Daytime running light operated			Q
86 (G)	Ground	Front fog lamp (RH)	Output	Lighting switch 2ND or AUTO (light is illumi- nated)	Front fog lamp switch ON	Battery voltage	R
					Lighting switch HI or PASS	0 V	S
					Front fog lamp switch OFF		T
87 (L)	Ground	Front fog lamp (LH)	Output	Lighting switch 2ND or AUTO (light is illumi- nated)	Front fog lamp switch ON	Battery voltage	U
					Lighting switch HI or PASS	0 V	V
					Front fog lamp switch OFF		W
88 (O)	Ground	Front wiper motor power supply	Output	Ignition switch ON		Battery voltage	X
89 (Y)	Ground	Headlamp HI (RH)	Output	Lighting switch 2ND or AUTO (light is illumi- nated)	Lighting switch HI or PASS	Battery voltage	Y
					Lighting switch other than HI and PASS	0 V	Z
90 (P)	Ground	Headlamp HI (LH)	Output	Lighting switch 2ND or AUTO (light is illumi- nated)	Lighting switch HI or PASS	Battery voltage	AA
					Lighting switch other than HI and PASS	0 V	AB

PCS

IPDM E/R

< ECU DIAGNOSIS INFORMATION >

[IPDM E/R]

Terminal No. (Wire color)		Description		Condition	Value (Approx.)
+	-	Signal name	Input/ Output		
96 (R)	Ground	Wiper reverse relay	Input	Ignition switch OFF or ACC	0 V
				Ignition switch ON	Battery voltage
				Front wiper operates at LO	Battery voltage
				Front wiper operates at HI	0 V
97 (V)	Ground	Cooling fan control	Output	Engine idling	0 – 5 V

*1: For models with VQ37VHR engine

*2: Models with steering lock unit

Fail-safe

INFOID:000000007152865

CAN COMMUNICATION CONTROL

When CAN communication with ECM and BCM is impossible, IPDM E/R performs fail-safe control. After CAN communication recovers normally, it also returns to normal control.

If No CAN Communication Is Available With ECM

Control part	Fail-safe operation
Cooling fan	<ul style="list-style-type: none"> • Outputs the pulse duty signal (PWM signal) 100% when the ignition switch is turned ON • Outputs the pulse duty signal (PWM signal) 0% when the ignition switch is turned OFF
A/C compressor	A/C relay OFF
Alternator	Outputs the power generation command signal (PWM signal) 0%

If No CAN Communication Is Available With BCM

Control part	Fail-safe operation
Headlamp	<ul style="list-style-type: none"> • Turns ON the headlamp low relay when the ignition switch is turned ON • Turns OFF the headlamp low relay when the ignition switch is turned OFF • Headlamp high relay OFF
<ul style="list-style-type: none"> • Parking lamp • License plate lamp • Illumination • Tail lamp • Side marker lamp 	<ul style="list-style-type: none"> • Turns ON the tail lamp relay and daytime running light relay when the ignition switch is turned ON • Turns OFF the tail lamp relay and daytime running light relay when the ignition switch is turned OFF
Front wiper motor	<ul style="list-style-type: none"> • The status just before activation of fail-safe control is maintained until the ignition switch is turned OFF while the front wiper is operating at LO or HI speed. • The wiper is operated at LO speed until the ignition switch is turned OFF if the fail-safe control is activated while the front wiper is set in the AUTO mode and the front wiper motor is operating. • Returns automatically wiper to stop position when ignition switch is turned ON if fail-safe control is activated while front wiper motor is operated and wiper stop in the other than stop position.
Front fog lamp	Front fog lamp relay OFF
Horn	Horn OFF
Ignition relay	The status just before activation of fail-safe is maintained.
Starter motor	Starter control relay OFF
Steering lock unit*	Steering lock relay OFF

*: For models with steering lock unit

IGNITION RELAY MALFUNCTION DETECTION FUNCTION

- IPDM E/R monitors the voltage at the contact circuit and excitation coil circuit of the ignition relay inside it.
- IPDM E/R judges the ignition relay error if the voltage differs between the contact circuit and the excitation coil circuit.

IPDM E/R

< ECU DIAGNOSIS INFORMATION >

[IPDM E/R]

- If the ignition relay cannot turn OFF due to contact seizure, it activates the tail lamp relay and daytime running light relay for 10 minutes to alert the user to the ignition relay malfunction when the ignition switch is turned OFF.

Voltage judgment		IPDM E/R judgment	Operation
Ignition relay contact side	Ignition relay excitation coil side		
ON	ON	Ignition relay ON normal	—
OFF	OFF	Ignition relay OFF normal	—
ON	OFF	Ignition relay ON stuck	<ul style="list-style-type: none"> • Detects DTC “B2098: IGN RELAY ON” • Turns ON the tail lamp relay and daytime running light relay for 10 minutes
OFF	ON	Ignition relay OFF stuck	Detects DTC “B2099: IGN RELAY OFF”

FRONT WIPER PROTECTION FUNCTION

IPDM E/R detects front wiper stop position by a front wiper stop position signal.

When a front wiper stop position signal is in the conditions listed below, IPDM E/R stops power supply to wiper after repeating a front wiper 10 seconds activation and 20 seconds stop five times.

Ignition switch	Front wiper switch	Front wiper stop position signal
ON	OFF	The front wiper stop position signal (stop position) cannot be input for 10 seconds.
	ON	The front wiper stop position signal does not change for 10 seconds.

NOTE:

This operation status can be confirmed on the IPDM E/R “Data Monitor” that displays “BLOCK” for the item “WIP PROT” while the wiper is stopped.

STARTER MOTOR PROTECTION FUNCTION

IPDM E/R turns OFF the starter control relay to protect the starter motor when the starter control relay remains active for 90 seconds.

DTC Index

INFOID:000000006887704

NOTE:

- The details of time display are as follows.
 - CRNT: A malfunction is detected now.
 - PAST: A malfunction was detected in the past.
- IGN counter is displayed on FFD (Freeze Frame Data).
 - The number is 0 when is detected now.
 - The number increases like 1 → 2 ... 38 → 39 after returning to the normal condition whenever IGN OFF → ON.
 - The number is fixed to 39 until the self-diagnosis results are erased if it is over 39.

×: Applicable

CONSULT display	Fail-safe	Reference
No DTC is detected. further testing may be required.	—	—
U1000: CAN COMM CIRCUIT	×	PCS-29
B2098: IGN RELAY ON	×	PCS-30
B2099: IGN RELAY OFF	—	PCS-31
B2108: S/L RELAY ON*	—	SEC-106
B2109: S/L RELAY OFF*	—	SEC-107
B210A: S/L STATE SW*	—	SEC-108
B210B: START CONT RLY ON	—	SEC-110

IPDM E/R

< ECU DIAGNOSIS INFORMATION >

[IPDM E/R]

CONSULT display	Fail-safe	Reference
B210C: START CONT RLY OFF	—	SEC-111
B210D: STARTER RELAY ON	—	SEC-112
B210E: STARTER RELAY OFF	—	SEC-113
B210F: INTRLCK/PNP SW ON	—	SEC-115
B2110: INTRLCK/PNP SW OFF	—	SEC-117

*: For models without steering lock unit, this DTC is not applied.

WIRING DIAGRAM

IPDM E/R

Wiring Diagram

INFOID:000000006887705

For connector terminal arrangements, harness layouts, and alphabets in a  (option abbreviation; if not described in wiring diagram), refer to [GI-12, "Connector Information"](#).

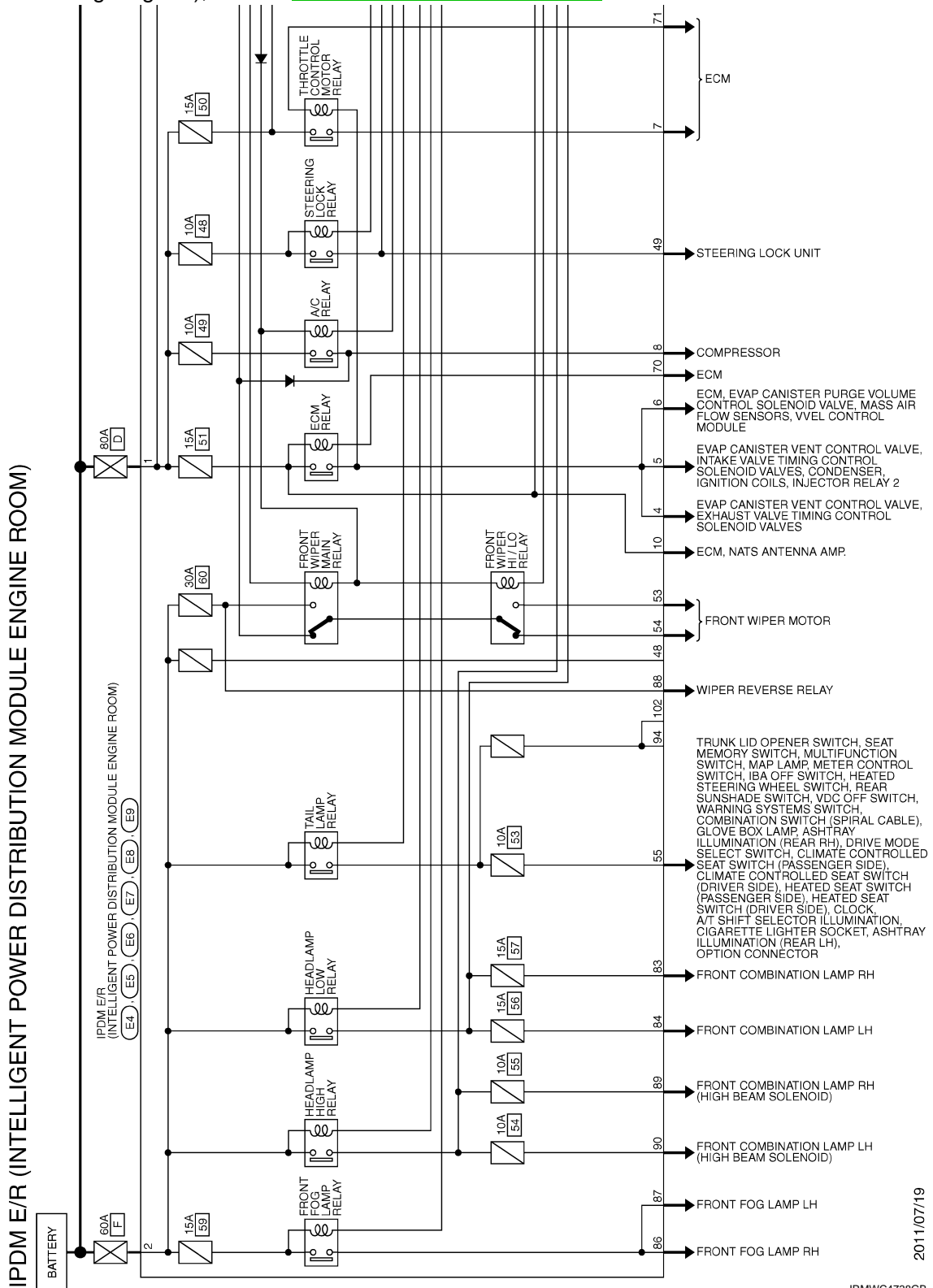

A
B
C
D
E
F
G
H
I
J
K
L
PCS
N
O
P

2011/07/19

JRMWC4738GB

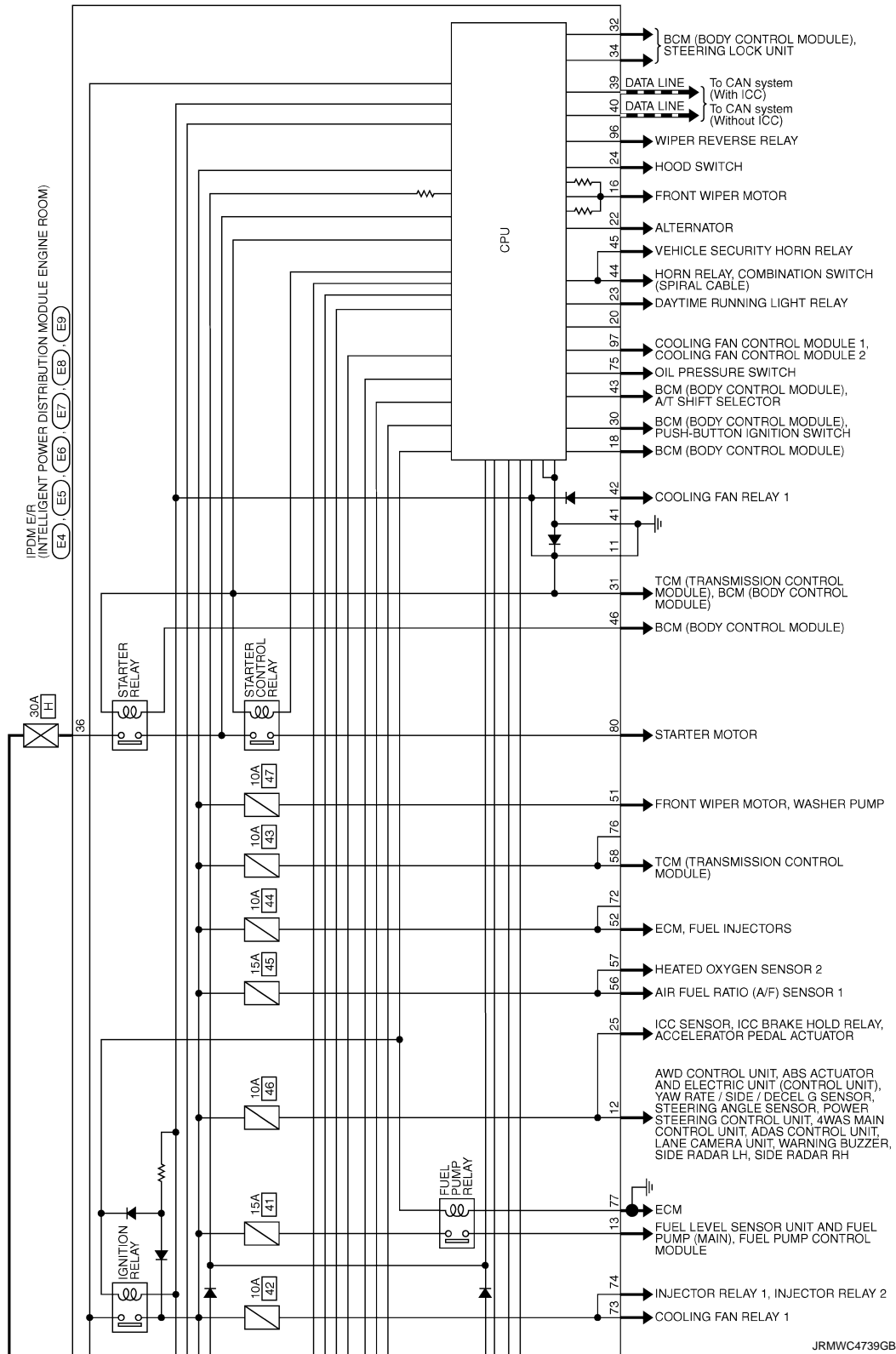

JRMWC4739GB

DTC/CIRCUIT DIAGNOSIS

U1000 CAN COMM CIRCUIT

Description

INFOID:000000006887706

CAN (Controller Area Network) is a serial communication line for real time applications. It is an on-vehicle multiplex communication line with high data communication speed and excellent error detection ability. Modern vehicle is equipped with many electronic control unit, and each control unit shares information and links with other control units during operation (not independent). In CAN communication, control units are connected with 2 communication lines (CAN-H line, CAN-L line) allowing a high rate of information transmission with less wiring. Each control unit transmits/receives data but selectively reads required data only.

CAN Communication Signal Chart. Refer to [LAN-35, "CAN COMMUNICATION SYSTEM : CAN Communication Signal Chart"](#).

DTC Logic

INFOID:000000006887707

DTC DETECTION LOGIC

DTC	CONSULT display description	DTC Detection Condition	Possible cause
U1000	CAN COMM CIRCUIT	When IPDM E/R cannot communicate CAN communication signal continuously for 2 seconds or more	CAN communication system

Diagnosis Procedure

INFOID:000000006887708

1. PERFORM SELF DIAGNOSTIC

1. Turn ignition switch ON and wait 2 seconds or more.
2. Check "Self Diagnostic Result" of "IPDM E/R" using CONSULT.

Is DTC "U1000" displayed?

- YES >> Refer to [LAN-25, "Trouble Diagnosis Flow Chart"](#).
- NO >> Refer to [GI-44, "Intermittent Incident"](#).

A
B
C
D
E
F
G
H
I
J
K
L

PCS

N
O
P

B2098 IGNITION RELAY ON STUCK

< DTC/CIRCUIT DIAGNOSIS >

[IPDM E/R]

B2098 IGNITION RELAY ON STUCK

Description

INFOID:000000006887709

- IPDM E/R operates the ignition relay when it receives an ignition switch ON signal from BCM via CAN communication.
- Turn the ignition relay OFF by pressing the push-button ignition switch once when the vehicle speed is 4 km/h (2.5 MPH) or less.
- Turn the ignition relay OFF with the following operation when the vehicle speed is more than 4 km/h (2.5 MPH) or when an abnormal condition occurs in CAN communication from the unified meter and A/C amp.(Emergency OFF)
 - Press and hold the push-button ignition switch for 2 seconds or more.
 - Press the push-button ignition switch 3 times within 1.5 seconds.

NOTE:

The ignition relay does not turn ON for 3 seconds after emergency OFF even if the push-button ignition switch is pressed.

DTC Logic

INFOID:000000006887710

DTC DETECTION LOGIC

DTC	CONSULT display description	DTC Detection Condition	Possible causes
B2098	IGN RELAY ON	The ignition relay ON is detected for 1 second at ignition switch OFF (CPU monitors the status at the contact and excitation coil circuits of the ignition relay inside it)	Ignition relay malfunction

Diagnosis Procedure

INFOID:000000006887711

1.PERFORM SELF DIAGNOSIS

1. Turn ignition switch ON.
2. Erase "Self Diagnostic Result" of "IPDM E/R" using CONSULT.
3. Turn ignition switch OFF, and wait 1 second or more.
4. Turn ignition switch ON.
5. Check "Self Diagnostic Result" of "IPDM E/R" using CONSULT.

Is DTC "B2098" displayed?

- YES >> Replace IPDM E/R. Refer to [PCS-33, "Removal and Installation"](#).
- NO >> Refer to [GI-44, "Intermittent Incident"](#).

B2099 IGNITION RELAY OFF STUCK

< DTC/CIRCUIT DIAGNOSIS >

[IPDM E/R]

B2099 IGNITION RELAY OFF STUCK

Description

INFOID:000000006887712

- IPDM E/R operates the ignition relay when it receives an ignition switch ON signal from BCM via CAN communication.
- Turn the ignition relay OFF by pressing the push-button ignition switch once when the vehicle speed is 4 km/h (2.5 MPH) or less.
- Turn the ignition relay OFF with the following operation when the vehicle speed is more than 4 km/h (2.5 MPH) or when an abnormal condition occurs in CAN communication from the unified meter and A/C amp.(Emergency OFF)
 - Press and hold the push-button ignition switch for 2 seconds or more.
 - Press the push-button ignition switch 3 times within 1.5 seconds.

NOTE:

The ignition relay does not turn ON for 3 seconds after emergency OFF even if the push-button ignition switch is pressed.

DTC Logic

INFOID:000000006887713

DTC DETECTION LOGIC

DTC	CONSULT display description	DTC Detection Condition	Possible causes
B2099	IGN RELAY OFF	The ignition relay OFF is detected for 1 second at ignition switch ON (CPU monitors the status at the contact and excitation coil circuits of the ignition relay inside it)	Ignition relay malfunction

NOTE:

When IPDM E/R power supply voltage is low (Approx. 7 - 8 V for about 1 second), the "DTC: B2099" may be detected.

Diagnosis Procedure

INFOID:000000006887714

1. PERFORM SELF DIAGNOSIS

1. Turn ignition switch ON.
2. Erase "Self Diagnostic Result" of "IPDM E/R" using CONSULT.
3. Turn ignition switch OFF.
4. Turn ignition switch ON.
5. Check "Self Diagnostic Result" of "IPDM E/R" using CONSULT.

Is "B2099" displayed?

- YES >> Replace IPDM E/R. Refer to [PCS-33, "Removal and Installation"](#).
 NO >> Refer to [GI-44, "Intermittent Incident"](#).

PCS

POWER SUPPLY AND GROUND CIRCUIT

< DTC/CIRCUIT DIAGNOSIS >

[IPDM E/R]

POWER SUPPLY AND GROUND CIRCUIT

Diagnosis Procedure

INFOID:000000006887715

1. CHECK FUSES AND FUSIBLE LINK

Check that the following IPDM E/R fuses or fusible links are not blown.

Signal name	Fuses and fusible link No.
Battery power supply	D (80 A)
	F (60 A)
	H (30 A)
	50 (15 A)
	51 (15 A)

Is the fuse fusing?

YES >> Replace the blown fuse or fusible link after repairing the affected circuit if a fuse or fusible link is blown.

NO >> GO TO 2.

2. CHECK POWER SUPPLY CIRCUIT

1. Turn the ignition switch OFF.
2. Disconnect IPDM E/R connector.
3. Check voltage between IPDM E/R harness connector and the ground.

(+)		(-)	Voltage (Approx.)
IPDM E/R			
Connector	Terminal	Ground	Battery voltage
E4	1		
	2		
E5	36		

Is the measurement value normal?

YES >> GO TO 3.

NO >> Repair the harness or connector.

3. CHECK GROUND CIRCUIT

Check continuity between IPDM E/R harness connectors and the ground.

IPDM E/R		Ground	Continuity
Connector	Terminal		
E5	11		Existed
E6	41		

Does continuity exist?

YES >> INSPECTION END

NO >> Repair the harness or connector.

REMOVAL AND INSTALLATION

IPDM E/R

Exploded View

INFOID:000000006887716

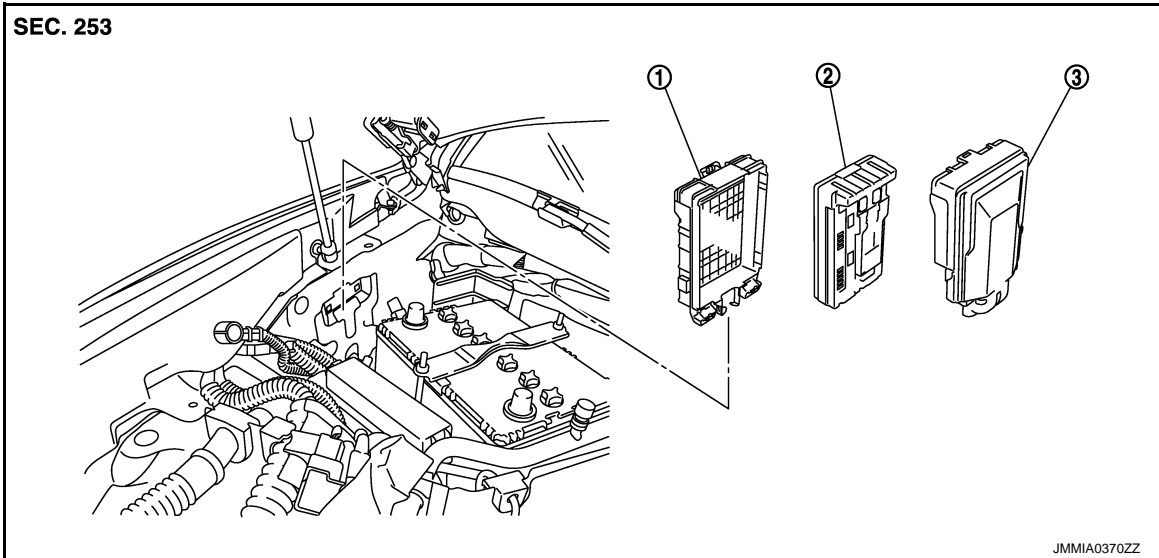

1. IPDM E/R cover A

2. IPDM E/R

3. IPDM E/R cover B

Removal and Installation

INFOID:000000006887717

CAUTION:

To prevent damage to the parts, IPDM E/R integrated relays cannot be removed.

REMOVAL

1. Disconnect the battery cable from the negative terminal.
2. Remove the cowl top cover (RH). Refer to [EXT-21, "Removal and Installation"](#).
3. Pull up the IPDM E/R assembly while pressing the pawls (A) on the back of the IPDM E/R cover B (1).

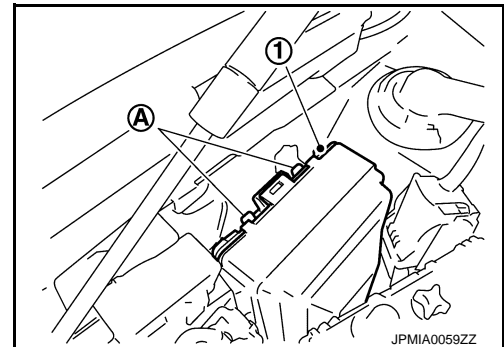

4. Remove the IPDM E/R cover A while pressing the pawls (A) at the lower end of the IPDM E/R cover A (1).
5. Disconnect the harness connector and remove the IPDM E/R (2).

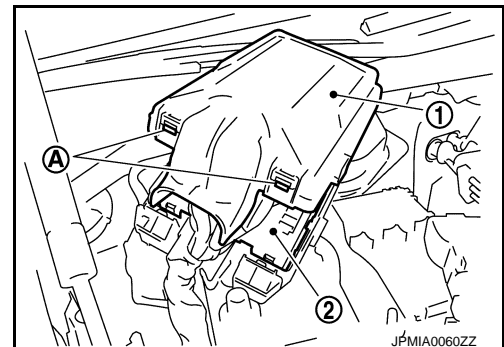

INSTALLATION

A
B
C
D
E
F
G
H
I
J
K
L
PCS
N
O
P

Install in the reverse order of removal.

PRECAUTION

PRECAUTIONS

Precaution for Supplemental Restraint System (SRS) "AIR BAG" and "SEAT BELT PRE-TENSIONER"

INFOID:000000006887718

The Supplemental Restraint System such as "AIR BAG" and "SEAT BELT PRE-TENSIONER", used along with a front seat belt, helps to reduce the risk or severity of injury to the driver and front passenger for certain types of collision. This system includes seat belt switch inputs and dual stage front air bag modules. The SRS system uses the seat belt switches to determine the front air bag deployment, and may only deploy one front air bag, depending on the severity of a collision and whether the front occupants are belted or unbelted. Information necessary to service the system safely is included in the "SRS AIR BAG" and "SEAT BELT" of this Service Manual.

WARNING:

Always observe the following items for preventing accidental activation.

- To avoid rendering the SRS inoperative, which could increase the risk of personal injury or death in the event of a collision that would result in air bag inflation, all maintenance must be performed by an authorized NISSAN/INFINITI dealer.
- Improper maintenance, including incorrect removal and installation of the SRS, can lead to personal injury caused by unintentional activation of the system. For removal of Spiral Cable and Air Bag Module, see "SRS AIR BAG".
- Never use electrical test equipment on any circuit related to the SRS unless instructed to in this Service Manual. SRS wiring harnesses can be identified by yellow and/or orange harnesses or harness connectors.

PRECAUTIONS WHEN USING POWER TOOLS (AIR OR ELECTRIC) AND HAMMERS

WARNING:

Always observe the following items for preventing accidental activation.

- When working near the Air Bag Diagnosis Sensor Unit or other Air Bag System sensors with the ignition ON or engine running, never use air or electric power tools or strike near the sensor(s) with a hammer. Heavy vibration could activate the sensor(s) and deploy the air bag(s), possibly causing serious injury.
- When using air or electric power tools or hammers, always switch the ignition OFF, disconnect the battery, and wait at least 3 minutes before performing any service.

Precautions Necessary for Steering Wheel Rotation After Battery Disconnection

INFOID:000000006887719

CAUTION:

Comply with the following cautions to prevent any error and malfunction.

- Before removing and installing any control units, first turn the ignition switch to the LOCK position, then disconnect both battery cables.
- After finishing work, confirm that all control unit connectors are connected properly, then re-connect both battery cables.
- Always use CONSULT to perform self-diagnosis as a part of each function inspection after finishing work. If a DTC is detected, perform trouble diagnosis according to self-diagnosis results.

For vehicle with steering lock unit, if the battery is disconnected or discharged, the steering wheel will lock and cannot be turned.

If turning the steering wheel is required with the battery disconnected or discharged, follow the operation procedure below before starting the repair operation.

OPERATION PROCEDURE

1. Connect both battery cables.

NOTE:

Supply power using jumper cables if battery is discharged.

2. Turn the ignition switch to ACC position.
(At this time, the steering lock will be released.)
3. Disconnect both battery cables. The steering lock will remain released with both battery cables disconnected and the steering wheel can be turned.

A
B
C
D
E
F
G
H
I
J
K
L
N
O
P

PCS

PRECAUTIONS

< PRECAUTION >

[POWER DISTRIBUTION SYSTEM]

4. Perform the necessary repair operation.
5. When the repair work is completed, re-connect both battery cables. With the brake pedal released, turn the ignition switch from ACC position to ON position, then to LOCK position. (The steering wheel will lock when the ignition switch is turned to LOCK position.)
6. Perform self-diagnosis check of all control units using CONSULT.

SYSTEM DESCRIPTION

COMPONENT PARTS

Component Parts Location

INFOID:000000006887720

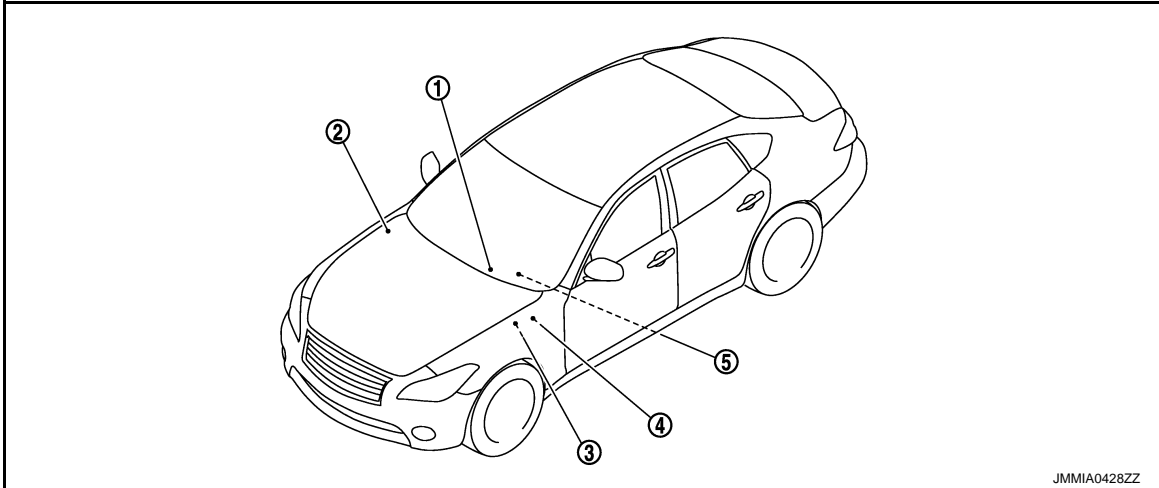

- 1. Push-button ignition switch
- 2. IPDM E/R
Refer to [PCS-5, "IPDM E/R : Component Parts Location"](#)
- 3. Stop lamp switch
Refer to [BRC-9, "Component Parts Location"](#)
- 4. BCM
Refer to [BCS-4, "BODY CONTROL SYSTEM : Component Parts Location"](#)
- 5. TCM
Refer to [TM-10, "A/T CONTROL SYSTEM : Component Parts Location"](#)

Component Description

INFOID:000000006887721

BCM	Reference
BCM	PCS-37
Ignition relay	PCS-37
Accessory relay	PCS-38
Blower relay	PCS-38
Push-button ignition switch	PCS-38
TCM	SEC-9
Stop lamp switch	SEC-11

BCM

INFOID:000000006887722

BCM controls the various electrical components and simultaneously supplies power according to the power supply position.
BCM checks the power supply position internally.

Ignition Relay

INFOID:000000006887723

BCM turns ON the following relays to supply ignition power supply or ignition switch ON signal to each ECU when the ignition switch is turned ON.

- Ignition relay (fuse block)
- Ignition relay (IPDM E/R)
- Blower relay

BCM compares following status comparing.

- Ignition relay (fuse block) control signal, and power supply position judged by BCM

COMPONENT PARTS

< SYSTEM DESCRIPTION >

[POWER DISTRIBUTION SYSTEM]

- Ignition relay (IPDM E/R) control request, and Ignition relay (IPDM E/R) status

Accessory Relay

INFOID:000000006887724

BCM turns ON the accessory relays to supply accessory power supply or ignition switch ACC signal to each ECU when the ignition switch is turned ACC or ON.

BCM compares status of accessory relay control signal, and power supply position judged by BCM.

Blower Relay

INFOID:000000006887725

BCM turns ON the following relays to supply ignition power supply or ignition switch ON signal to each ECU when the ignition switch is turned ON.

- Ignition relay (fuse block)
- Ignition relay (IPDM E/R)
- Blower relay

BCM compares status of blower relay control signal, and power supply position judged by BCM.

Push-Button Ignition Switch

INFOID:000000006887726

BCM transmits the change in the power supply position with the push-button ignition switch to IPDM E/R via CAN communication line. IPDM E/R transmits the power supply position status via CAN communication line to BCM.

SYSTEM

POWER DISTRIBUTION SYSTEM

POWER DISTRIBUTION SYSTEM : System Diagram

INFOID:0000000006887727

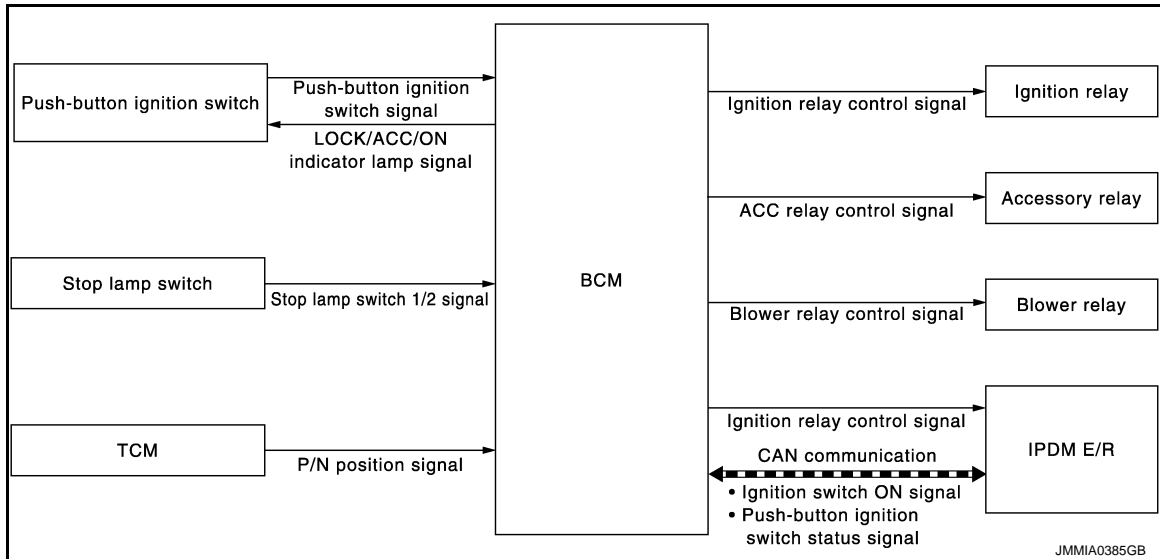

POWER DISTRIBUTION SYSTEM : System Description

INFOID:0000000006887728

SYSTEM DESCRIPTION

- PDS (POWER DISTRIBUTION SYSTEM) is the system that BCM controls with the operation of the push-button ignition switch and performs the power distribution to each power circuit. This system is used instead of the mechanical power supply changing mechanism with the operation of the conventional key cylinder.
- The push-button ignition switch can be operated when Intelligent Key is in the following condition.
 - Intelligent Key is in the detection area of the inside key antenna.
 - Intelligent Key backside is contacted to push-button ignition switch.
- The push-button ignition switch operation is input to BCM as a signal. BCM changes the power supply position according to the status and operates the following relays to supply power to each power circuit.
 - Ignition relay (IPDM E/R)
 - Ignition relay (fuse block)
 - ACC relay
 - Blower fan relay
- The power supply position changes due to the conditions of push-button ignition switch operation, brake pedal, clutch pedal, selector lever and vehicle speed.

NOTE:

- The power supply position can be confirmed with the lighting of the indicators near the push-button ignition switch.
- For models without steering lock unit, power supply position changes from "OFF" to "LOCK" when steering lock conditions are satisfied.

BATTERY SAVER SYSTEM

When all the following conditions are met for 60 minutes, the battery saver system will cut off the power supply to prevent battery discharge.

- The ignition switch is in the ACC position
- All doors are closed
- Selector lever is in the P position

Reset Condition of Battery Saver System

If any of the following conditions are met the battery saver system is released and the steering will change automatically to the LOCK position from the OFF position.

- Opening any door
- Operating with door key cylinder on door lock
- Operating with request switch on door lock
- Operating with Intelligent Key on door lock

A
B
C
D
E
F
G
H
I
J
K
L
N
O
P

PCS

SYSTEM

< SYSTEM DESCRIPTION >

[POWER DISTRIBUTION SYSTEM]

Press push-button ignition switch and ignition switch will change to the ACC position from the OFF position.

STEERING LOCK OPERATION (MODELS WITH STEERING LOCK UNIT)

Steering is locked by steering lock unit when ignition switch is in the OFF position, selector lever is in the P position and any of the following conditions are met.

- Opening door
- Closing door
- Door is locked with door request switch
- Door is locked with Intelligent Key

POWER SUPPLY POSITION CHANGE TABLE BY PUSH-BUTTON IGNITION SWITCH OPERATION

The power supply position changing operation can be performed with the following operations.

NOTE:

- When an Intelligent Key is within the detection area of inside key antenna and when Intelligent Key backside is contacted to push-button ignition switch, it is equivalent to the operations below.
- When starting the engine, the BCM monitors under the engine start conditions,
 - Brake pedal operating condition
 - Selector lever position
 - Vehicle speed

Vehicle speed: less than 4 km/h (2.5 MPH)

Power supply position	Engine start/stop condition		Push-button ignition switch operation frequency
	Selector lever position	Brake pedal operation condition	
LOCK → ACC	—	Not depressed	1
LOCK → ACC → ON	—	Not depressed	2
LOCK → ACC → ON → OFF	—	Not depressed	3
LOCK → START ACC → START ON → START	P or N position	Depressed	1
Engine is running → OFF	—	—	1

Vehicle speed: 4 km/h (2.5 MPH) or more

Power supply position	Engine start/stop condition		Push-button ignition switch operation frequency
	Selector lever position	Brake pedal operation condition	
Engine is running → ACC	—	—	Emergency stop operation
Engine stall return operation while driving	N position	Not depressed	1

Emergency stop operation

- Press and hold the push-button ignition switch for 2 seconds or more.
- Press the push-button ignition switch 3 times or more within 1.5 seconds.

Fail-safe

INFOID:000000007215652

FAIL-SAFE CONTROL BY DTC

BCM performs fail-safe control when any DTC are detected.

Display contents of CONSULT	Fail-safe	Cancellation
B2013: ID DISCORD BCM-S/L	Inhibit engine cranking	When communication between BCM and steering lock unit are communicated normally.
B2014: CHAIN OF S/L-BCM	Inhibit engine cranking	When communication between BCM and steering lock unit are communicated normally.
B2192: ID DISCORD BCM-ECM	Inhibit engine cranking	Erase DTC
B2193: CHAIN OF BCM-ECM	Inhibit engine cranking	Erase DTC

SYSTEM

< SYSTEM DESCRIPTION >

[POWER DISTRIBUTION SYSTEM]

Display contents of CONSULT	Fail-safe	Cancellation	
B2195: ANTI-SCANNING	Inhibit engine cranking	Ignition switch ON → OFF	A
B2196: DONGLE NG	Inhibit engine cranking	Erase DTC	
B2198: NATS ANTENNA AMP	Inhibit engine cranking	Erase DTC	B
B2557: VEHICLE SPEED	Inhibit steering lock	When the following CAN signal status (vehicle speed signal) becomes consistent <ul style="list-style-type: none"> • Vehicle speed signal (ABS) • Vehicle speed signal (Meter) 	C
B2601: SHIFT POSITION	Inhibit steering lock	500 ms after the following signal reception status becomes consistent <ul style="list-style-type: none"> • P position switch signal • P range signal (CAN) 	D
B2602: SHIFT POSITION	Inhibit steering lock	5 seconds after the following BCM recognition conditions are fulfilled <ul style="list-style-type: none"> • Ignition switch is in the ON position • P position switch signal: Except P position (battery voltage) • Vehicle speed: 4 km/h (2.5 MPH) or more 	E
B2603: SHIFT POSI STATUS	Inhibit steering lock	500 ms after any of the following BCM recognition conditions are fulfilled <ul style="list-style-type: none"> • Status 1 <ul style="list-style-type: none"> - Ignition switch is in the ON position - P position switch signal: Except P position (12 V) - P/N position signal: Except P and N positions (0 V) • Status 2 <ul style="list-style-type: none"> - Ignition switch is in the ON position - P position switch signal: P position (0 V) - P/N position signal: P or N positions (12 V) 	F
B2604: PNP/CLUTCH SW	Inhibit steering lock	500 ms after any of the following BCM recognition conditions are fulfilled <ul style="list-style-type: none"> • Status 1 <ul style="list-style-type: none"> - Ignition switch is in the ON position - P/N position signal: P or N position (12 V) - Shift position signal (CAN): P or N position • Status 2 <ul style="list-style-type: none"> - Ignition switch is in the ON position - P/N position signal: Except P and N positions (0 V) - Shift position signal (CAN): Except P and N position 	G
B2605: PNP/CLUTCH SW	Inhibit steering lock	500 ms after any of the following BCM recognition conditions are fulfilled <ul style="list-style-type: none"> • Status 1 <ul style="list-style-type: none"> - Power position: IGN - P/N position signal: Except P and N positions (0 V) - Interlock/PNP switch signal (CAN): OFF • Status 2 <ul style="list-style-type: none"> - Ignition switch is in the ON position - P/N position signal: P or N position (12 V) - Interlock/PNP switch signal (CAN): ON 	H
B2608: STARTER RELAY	Inhibit engine cranking	500 ms after the following signal communication status becomes consistent <ul style="list-style-type: none"> • Starter motor relay control signal • Starter relay status signal (CAN) 	I
B2609: S/L STATUS	<ul style="list-style-type: none"> • Inhibit engine cranking • Inhibit steering lock 	When the following steering lock conditions agree <ul style="list-style-type: none"> • BCM steering lock control status • Steering lock condition No. 1 signal status • Steering lock condition No. 2 signal status 	J
B260B: STEERING LOCK UNIT	Inhibit steering lock	Erase DTC	K
B260D: STEERING LOCK UNIT	Inhibit steering lock	Erase DTC	L
B260F: ENG STATE SIG LOST	Inhibit engine cranking	When any of the following conditions are fulfilled <ul style="list-style-type: none"> • Power position changes to ACC • Receives engine status signal (CAN) 	PCS

SYSTEM

< SYSTEM DESCRIPTION >

[POWER DISTRIBUTION SYSTEM]

Display contents of CONSULT	Fail-safe	Cancellation
B2612: S/L STATUS	<ul style="list-style-type: none"> Inhibit engine cranking Inhibit steering lock 	When any of the following conditions are fulfilled <ul style="list-style-type: none"> Steering lock unit status signal (CAN) is received normally The BCM steering lock control status matches the steering lock status recognized by the steering lock unit status signal (CAN from IPDM E/R)
B2619: BCM	Inhibit engine cranking	1 second after the steering lock unit power supply output control inside BCM becomes normal
B26EF: STRG LCK RELAY OFF	Inhibit engine cranking	When the following conditions are fulfilled <ul style="list-style-type: none"> Steering lock relay signal (CAN): ON Steering lock unit status signal (CAN): ON
B26F0: STRG LCK RELAY ON	Inhibit engine cranking	When the following conditions are fulfilled <ul style="list-style-type: none"> Steering lock relay signal (CAN): OFF Steering lock unit status signal (CAN): OFF
B26F1: IGN RELAY OFF	Inhibit engine cranking	When the following conditions are fulfilled <ul style="list-style-type: none"> Ignition switch ON signal (CAN: Transmitted from BCM): ON Ignition switch ON signal (CAN: Transmitted from IPDM E/R): ON
B26F2: IGN RELAY ON	Inhibit engine cranking	When the following conditions are fulfilled <ul style="list-style-type: none"> Ignition switch ON signal (CAN: Transmitted from BCM): OFF Ignition switch ON signal (CAN: Transmitted from IPDM E/R): OFF
B26F3: START CONT RLY ON	Inhibit engine cranking	When the following conditions are fulfilled <ul style="list-style-type: none"> Starter control relay signal (CAN: Transmitted from BCM): OFF Starter control relay signal (CAN: Transmitted from IPDM E/R): OFF
B26F4: START CONT RLY OFF	Inhibit engine cranking	When the following conditions are fulfilled <ul style="list-style-type: none"> Starter control relay signal (CAN: Transmitted from BCM): ON Starter control relay signal (CAN: Transmitted from IPDM E/R): ON
B26F7: BCM	Inhibit engine cranking by Intelligent Key system	When room antenna and luggage room antenna functions normally
U0415: VEHICLE SPEED	Inhibit steering lock	When vehicle speed signal (Meter) (CAN) is received normally

FAIL-SAFE CONTROL BY RAIN SENSOR MALFUNCTION

BCM detects the light and rain sensor serial link error and the rain sensor malfunction.

BCM controls the following fail-safe when rain sensor has a malfunction.

- Front wiper switch AUTO and sensing rain drop: The condition just before the activation of fail-safe is maintained until the front wiper switch is turned OFF.
- Front wiper switch AUTO and not sensing rain drop: Front wiper is LO operation until the front wiper switch is turned off.

FAIL-SAFE CONTROL OF COMBINATION SWITCH READING FUNCTION CAUSED BY LOW POWER SUPPLY VOLTAGE

If voltage of battery power supply lower, BCM maintains combination switch reading to the status when input voltage is less than approximately 9 V.

NOTE:

When voltage of battery power supply is approximately 9 V or more, combination switch reading function returns to normal operation.

DIAGNOSIS SYSTEM (BCM)

[POWER DISTRIBUTION SYSTEM]

< SYSTEM DESCRIPTION >

DIAGNOSIS SYSTEM (BCM)

COMMON ITEM

COMMON ITEM : CONSULT Function (BCM - COMMON ITEM)

INFOID:000000007215653

APPLICATION ITEM

CONSULT performs the following functions via CAN communication with BCM.

Diagnosis mode	Function Description
Work Support	Changes the setting for each system function.
Self Diagnostic Result	Displays the diagnosis results judged by BCM.
CAN Diag Support Monitor	Monitors the reception status of CAN communication viewed from BCM.
Data Monitor	The BCM input/output signals are displayed.
Active Test	The signals used to activate each device are forcibly supplied from BCM.
Ecu Identification	The BCM part number is displayed.
Configuration	<ul style="list-style-type: none"> Read and save the vehicle specification. Write the vehicle specification when replacing BCM.

SYSTEM APPLICATION

BCM can perform the following functions for each system.

NOTE:

It can perform the diagnosis modes except the following for all sub system selection items.

x: Applicable item

System	Sub system selection item	Diagnosis mode		
		Work Support	Data Monitor	Active Test
Door lock	DOOR LOCK	x	x	x
Rear window defogger	REAR DEFOGGER		x	x
Warning chime	BUZZER		x	x
Interior room lamp timer	INT LAMP	x	x	x
Exterior lamp	HEAD LAMP	x	x	x
Wiper and washer	WIPER	x	x	x
Turn signal and hazard warning lamps	FLASHER	x	x	x
—	AIR CONDITONER*		x	x
<ul style="list-style-type: none"> Intelligent Key system Engine start system 	INTELLIGENT KEY	x	x	x
Combination switch	COMB SW		x	
Body control system	BCM	x		
IVIS - NATS	IMMU	x	x	x
Interior room lamp battery saver	BATTERY SAVER	x	x	x
Trunk lid open	TRUNK		x	
Vehicle security system	THEFT ALM	x	x	x
RAP system	RETAINED PWR		x	
Signal buffer system	SIGNAL BUFFER		x	x
—	AIR PRESSURE MONITOR*	x	x	x

*: This item is not used.

FREEZE FRAME DATA (FFD)

The BCM records the following vehicle condition at the time a particular DTC is detected, and displays on CONSULT.

DIAGNOSIS SYSTEM (BCM)

[POWER DISTRIBUTION SYSTEM]

< SYSTEM DESCRIPTION >

CONSULT screen item	Indication/Unit	Description	
Vehicle Speed	km/h	Vehicle speed of the moment a particular DTC is detected	
Odo/Trip Meter	km	Total mileage (Odometer value) of the moment a particular DTC is detected	
Vehicle Condition	SLEEP>LOCK	Power position status of the moment a particular DTC is detected	While turning BCM status from low power consumption mode to normal mode (Power supply position is "LOCK"*)
	SLEEP>OFF		While turning BCM status from low power consumption mode to normal mode (Power supply position is "OFF".)
	LOCK>ACC		While turning power supply position from "LOCK" *to "ACC"
	ACC>ON		While turning power supply position from "ACC" to "IGN"
	RUN>ACC		While turning power supply position from "RUN" to "ACC" (Vehicle is stopping and selector lever is except P position.)
	CRANK>RUN		While turning power supply position from "CRANKING" to "RUN" (From cranking up the engine to run it)
	RUN>URGENT		While turning power supply position from "RUN" to "ACC" (Emergency stop operation)
	ACC>OFF		While turning power supply position from "ACC" to "OFF"
	OFF>LOCK		While turning power supply position from "OFF" to "LOCK"*
	OFF>ACC		While turning power supply position from "OFF" to "ACC"
	ON>CRANK		While turning power supply position from "IGN" to "CRANKING"
	OFF>SLEEP		While turning BCM status from normal mode (Power supply position is "OFF".) to low power consumption mode
	LOCK>SLEEP		While turning BCM status from normal mode (Power supply position is "LOCK"*.) to low power consumption mode
	LOCK		Power supply position is "LOCK" (Ignition switch OFF with steering is locked.)*
	OFF		Power supply position is "OFF" (Ignition switch OFF with steering is unlocked.)
	ACC		Power supply position is "ACC" (Ignition switch ACC)
	ON		Power supply position is "IGN" (Ignition switch ON with engine stopped)
	ENGINE RUN		Power supply position is "RUN" (Ignition switch ON with engine running)
CRANKING	Power supply position is "CRANKING" (At engine cranking)		
IGN Counter	0 - 39	The number of times that ignition switch is turned ON after DTC is detected <ul style="list-style-type: none"> • The number is 0 when a malfunction is detected now. • The number increases like 1 → 2 → 3...38 → 39 after returning to the normal condition whenever ignition switch OFF → ON. • The number is fixed to 39 until the self-diagnosis results are erased if it is over 39. 	

NOTE:

*: For models without steering lock unit, power supply position changes from "OFF" to "LOCK" when steering lock conditions are satisfied.

INTELLIGENT KEY

INTELLIGENT KEY : CONSULT Function (BCM - INTELLIGENT KEY)

INFOID:000000007215654

WORK SUPPORT

DIAGNOSIS SYSTEM (BCM)

[POWER DISTRIBUTION SYSTEM]

< SYSTEM DESCRIPTION >

Monitor item	Description	A
INSIDE ANT DIAGNOSIS	This function allows inside key antenna self-diagnosis	A
LOCK/UNLOCK BY I-KEY	Door lock/unlock function by door request switch mode can be changed to operation in this mode <ul style="list-style-type: none"> • On: Operate • Off: Non-operation 	B
ENGINE START BY I-KEY	Engine start function mode can be changed to operation with this mode <ul style="list-style-type: none"> • On: Operate • Off: Non-operation 	C
TRUNK/GLASS HATCH OPEN	Buzzer reminder function mode by trunk lid opener request switch and Intelligent Key can be changed to operation with this mode <ul style="list-style-type: none"> • On: Operate • Off: Non-operation 	D
PANIC ALARM SET	Panic alarm button pressing time on Intelligent Key remote control button can be selected from the following with this mode <ul style="list-style-type: none"> • MODE 1: 0.5 sec • MODE 2: Non-operation • MODE 3: 1.5 sec 	E
TRUNK OPEN DELAY	Trunk button pressing on Intelligent Key can be selected as per the following in this mode. <ul style="list-style-type: none"> • MODE 1: Press and hold • MODE 2: Press twice • MODE 3: Press and hold, or press twice 	F
LO- BATT OF KEY FOB WARN	Intelligent Key low battery warning mode can be changed to operation with this mode <ul style="list-style-type: none"> • On: Operate • Off: Non-operation 	G
ANTI KEY LOCK IN FUNCTI	Key reminder function mode can be changed to operation with this mode <ul style="list-style-type: none"> • On: Operate • Off: Non-operation 	H
HAZARD ANSWER BACK	Hazard reminder function mode by door request switch and Intelligent Key button can be selected from the following with this mode <ul style="list-style-type: none"> • Lock Only: Door lock operation only • Unlock Only: Door unlock operation only • Lock/Unlock: Lock and unlock operation • Off: Non-operation 	I
ANS BACK I-KEY LOCK	Buzzer reminder function (lock operation) mode by door request switch can be selected from the following with this mode <ul style="list-style-type: none"> • Horn Chirp: Sound horn • Buzzer: Sound Intelligent Key warning buzzer • Off: Non-operation 	J
ANS BACK I-KEY UNLOCK	Buzzer reminder function (unlock operation) mode by door request switch can be changed to operation with this mode <ul style="list-style-type: none"> • On: Operate • Off: Non-operation 	K
SHORT CRANKING OUTPUT	Starter motor can operate during the times below <ul style="list-style-type: none"> • 70 msec • 100 msec • 200 msec 	L
CONFIRM KEY FOB ID	It can be checked whether Intelligent Key ID code is registered or not in this mode	PCS
AUTO LOCK SET	Auto door lock operation time can be changed in this mode <ul style="list-style-type: none"> • MODE 1: OFF • MODE 2: 30 sec • MODE 3: 1 minute • MODE 4: 2 minutes • MODE 5: 3 minutes • MODE 6: 4 minutes • MODE 7: 5 minutes 	N
		O
		P

DIAGNOSIS SYSTEM (BCM)

[POWER DISTRIBUTION SYSTEM]

< SYSTEM DESCRIPTION >

Monitor item	Description
HORN WITH KEYLESS LOCK	Horn reminder function mode by Intelligent Key button can be selected from the following with this mode <ul style="list-style-type: none"> • On: Operate • Off: Non-operation
PW DOWN SET	Unlock button pressing time on Intelligent Key button can be selected from the following with this mode <ul style="list-style-type: none"> • MODE 1: 3 sec • MODE 2: Non-operation • MODE 3: 5 sec
WELCOME LIGHT SELECT	Welcome light function mode can be selected from the following with this mode <ul style="list-style-type: none"> • Puddle/Outside Handle • Room lamp • Head & Tail Lamps (this item is displayed, but cannot be used) • Heart Beat
WELCOME LIGHT OP SET	Welcome light function mode can be changed to operation with this mode <ul style="list-style-type: none"> • On: Operate • Off: Non-operation
INTELLIGENT KEY SETUP	Intelligent Key interlock function mode can be changed to operation with this mode <ul style="list-style-type: none"> • On: Operate • Off: Non-operation

SELF-DIAG RESULT

Refer to [BCS-57, "DTC Index"](#).

DATA MONITOR

Monitor Item	Condition
REQ SW -DR	Indicates [On/Off] condition of door request switch (driver side)
REQ SW -AS	Indicates [On/Off] condition of door request switch (passenger side)
REQ SW -BD/TR	Indicates [On/Off] condition of trunk lid opener request switch
PUSH SW	Indicates [On/Off] condition of push-button ignition switch
CLUTCH SW	NOTE: This item is displayed, but cannot be monitored
BRAKE SW 1	Indicates [On/Off]* condition of stop lamp switch power supply
BRAKE SW 2	Indicates [On/Off] condition of stop lamp switch
DETE/CANCL SW	Indicates [On/Off] condition of P position
SFT PN/N SW	Indicates [On/Off] condition of P or N position
S/L -LOCK	Indicates [On/Off] condition of steering lock unit (LOCK) NOTE: For models without steering lock unit, this item is not monitored.
S/L -UNLOCK	Indicates [On/Off] condition of steering lock unit (UNLOCK) NOTE: For models without steering lock unit, this item is not monitored.
S/L RELAY -F/B	Indicates [On/Off] condition of steering lock relay NOTE: For models without steering lock unit, this item is not monitored.
UNLK SEN -DR	Indicates [On/Off] condition of driver door UNLOCK status
PUSH SW -IPDM	Indicates [On/Off] condition of push-button ignition switch
IGN RLY1 -F/B	Indicates [On/Off] condition of ignition relay 1
DETE SW -IPDM	Indicates [On/Off] condition of P position
SFT PN -IPDM	Indicates [On/Off] condition of P or N position
SFT P -MET	Indicates [On/Off] condition of P position
SFT N -MET	Indicates [On/Off] condition of N position

DIAGNOSIS SYSTEM (BCM)

< SYSTEM DESCRIPTION >

[POWER DISTRIBUTION SYSTEM]

Monitor Item	Condition
ENGINE STATE	Indicates [Stop/Stall/Crank/Run] condition of engine states
S/L LOCK-IPDM	Indicates [On/Off] condition of steering lock unit (LOCK) NOTE: For models without steering lock unit, this item is not monitored.
S/L UNLK-IPDM	Indicates [On/Off] condition of steering lock unit (UNLOCK) NOTE: For models without steering lock unit, this item is not monitored.
S/L RELAY-REQ	Indicates [On/Off] condition of steering lock relay NOTE: For models without steering lock unit, this item is not monitored.
VEH SPEED 1	Display the vehicle speed signal received from combination meter by numerical value [Km/h]
VEH SPEED 2	Display the vehicle speed signal received from ABS or VDC or TCM by numerical value [Km/h]
DOOR STAT-DR	Indicates [LOCK/READY/UNLK] condition of driver side door status
DOOR STAT-AS	Indicates [LOCK/READY/UNLK] condition of passenger side door status
ID OK FLAG	Indicates [Set/Reset] condition of key ID
PRMT ENG STRT	Indicates [Set/Reset] condition of engine start possibility
PRMT RKE STRT	NOTE: This item is displayed, but cannot be monitored
TRNK/HAT MNTR	Indicates [On/Off] condition of trunk room lamp switch
RKE-LOCK	Indicates [On/Off] condition of LOCK signal from Intelligent Key
RKE-UNLOCK	Indicates [On/Off] condition of UNLOCK signal from Intelligent Key
RKE-TR/BD	Indicates [On/Off] condition of trunk open signal from Intelligent Key
RKE-PANIC	Indicates [On/Off] condition of panic alarm button of Intelligent Key
RKE-MODE CHG	Indicates [On/Off] condition of MODE CHANGE signal from Intelligent Key
RKE OPE COUN1	When remote keyless entry receiver receives the signal transmitted while operating on Intelligent Key, the numerical value start changing
RKE OPE COUN2	NOTE: This item is displayed, but cannot be monitored

*: OFF is displayed when brake pedal is depressed while brake switch power supply is OFF.

ACTIVE TEST

Test item	Description
BATTERY SAVER	This test is able to check interior room lamp operation <ul style="list-style-type: none"> • On: Operate • Off: Non-operation
OUTSIDE BUZZER	This test is able to check Intelligent Key warning buzzer operation <ul style="list-style-type: none"> • On: Operate • Off: Non-operation
INSIDE BUZZER	This test is able to check warning chime in combination meter operation <ul style="list-style-type: none"> • Take Out: Take away warning chime sounds when CONSULT screen is touched • Key: Key warning chime sounds when CONSULT screen is touched • Knob: OFF position warning chime sounds when CONSULT screen is touched • Off: Non-operation
INDICATOR	This test is able to check warning lamp operation <ul style="list-style-type: none"> • KEY ON: "KEY" Warning lamp illuminates when CONSULT screen is touched • KEY IND: "KEY" Warning lamp blinks when CONSULT screen is touched • Off: Non-operation
INT LAMP	This test is able to check interior room lamp operation <ul style="list-style-type: none"> • On: Operate • Off: Non-operation

DIAGNOSIS SYSTEM (BCM)

< SYSTEM DESCRIPTION >

[POWER DISTRIBUTION SYSTEM]

Test item	Description
LCD	<p>This test is able to check meter display information</p> <ul style="list-style-type: none"> • Engine start information displays when "BP N" on CONSULT screen is touched • Engine start information displays when "BP I" on CONSULT screen is touched • Key ID warning displays when "ID NG" on CONSULT screen is touched • Steering lock information displays when "ROTAT" on CONSULT screen is touched <p>NOTE: For models without steering lock unit, "ROTAT" is displayed, but cannot be tested.</p> <ul style="list-style-type: none"> • P position warning displays when "SFT P" on CONSULT screen is touched • INSRT: This item is displayed, but cannot be monitored • BATT: This item is displayed, but cannot be monitored • Take away through window warning displays when "NO KY" on CONSULT screen is touched • Take away warning display when "OUTKEY" on CONSULT screen is touched • OFF position warning display when "LK WN" on CONSULT screen is touched
FLASHER	<p>This test is able to check hazard warning lamp operation The hazard warning lamps are activated after "LH/RH/Off" on CONSULT screen is touched</p>
P RANGE	<p>This test is able to check AT shift selector power supply</p> <ul style="list-style-type: none"> • On: Operate • Off: Non-operation
ENGINE SW ILLUMI	<p>This test is able to check push-ignition switch illumination operation Push-ignition switch illumination illuminates when "ON" on CONSULT screen is touched</p>
LOCK INDICATOR	<p>This test is able to check LOCK indicator (push-button ignition switch) operation</p> <ul style="list-style-type: none"> • On: Operate • Off: Non-operation
ACC INDICATOR	<p>This test is able to check ACC indicator (push-button ignition switch) operation</p> <ul style="list-style-type: none"> • On: Operate • Off: Non-operation
IGNITION ON IND	<p>This test is able to check ON indicator (push-button ignition switch) operation</p> <ul style="list-style-type: none"> • On: Operate • Off: Non-operation
HORN	<p>This test is able to check horn operation</p> <ul style="list-style-type: none"> • On: Operate • Off: Non-operation
TRUNK/BACK DOOR	<p>This test is able to check trunk lid open operation</p> <ul style="list-style-type: none"> • Open: Operate
INTELLIGENT KEY LINK	<p>This test is able to check Intelligent Key interlock function</p> <ul style="list-style-type: none"> • ID No1: BCM transmits Intelligent Key ID No1 to each control unit • ID No2: BCM transmits Intelligent Key ID No2 to each control unit
INTELLIGENT KEY LINK (CAN)	<p>This test is able to check Intelligent Key interlock function</p> <ul style="list-style-type: none"> • Off: Non-operation • ID No1: BCM transmits Intelligent Key ID No1 to each control unit via CAN communication line • ID No2: BCM transmits Intelligent Key ID No2 to each control unit via CAN communication line • ID No3: BCM transmits Intelligent Key ID No3 to each control unit via CAN communication line • ID No4: BCM transmits Intelligent Key ID No4 to each control unit via CAN communication line • ID No5: This item is displayed, but cannot be used

ECU DIAGNOSIS INFORMATION

BCM

List of ECU Reference

INFOID:0000000006887732

ECU	Reference
BCM	BCS-34. "Reference Value"
	BCS-54. "Fail-safe"
	BCS-56. "DTC Inspection Priority Chart"
	BCS-57. "DTC Index"

A
B
C
D
E
F
G
H
I
J
K
L
N
O
P

PCS

POWER DISTRIBUTION SYSTEM

< WIRING DIAGRAM >

[POWER DISTRIBUTION SYSTEM]

WIRING DIAGRAM

POWER DISTRIBUTION SYSTEM

Wiring Diagram

INFOID:000000006887733

For connector terminal arrangements, harness layouts, and alphabets in a  (option abbreviation; if not described in wiring diagram), refer to [GI-12. "Connector Information"](#).

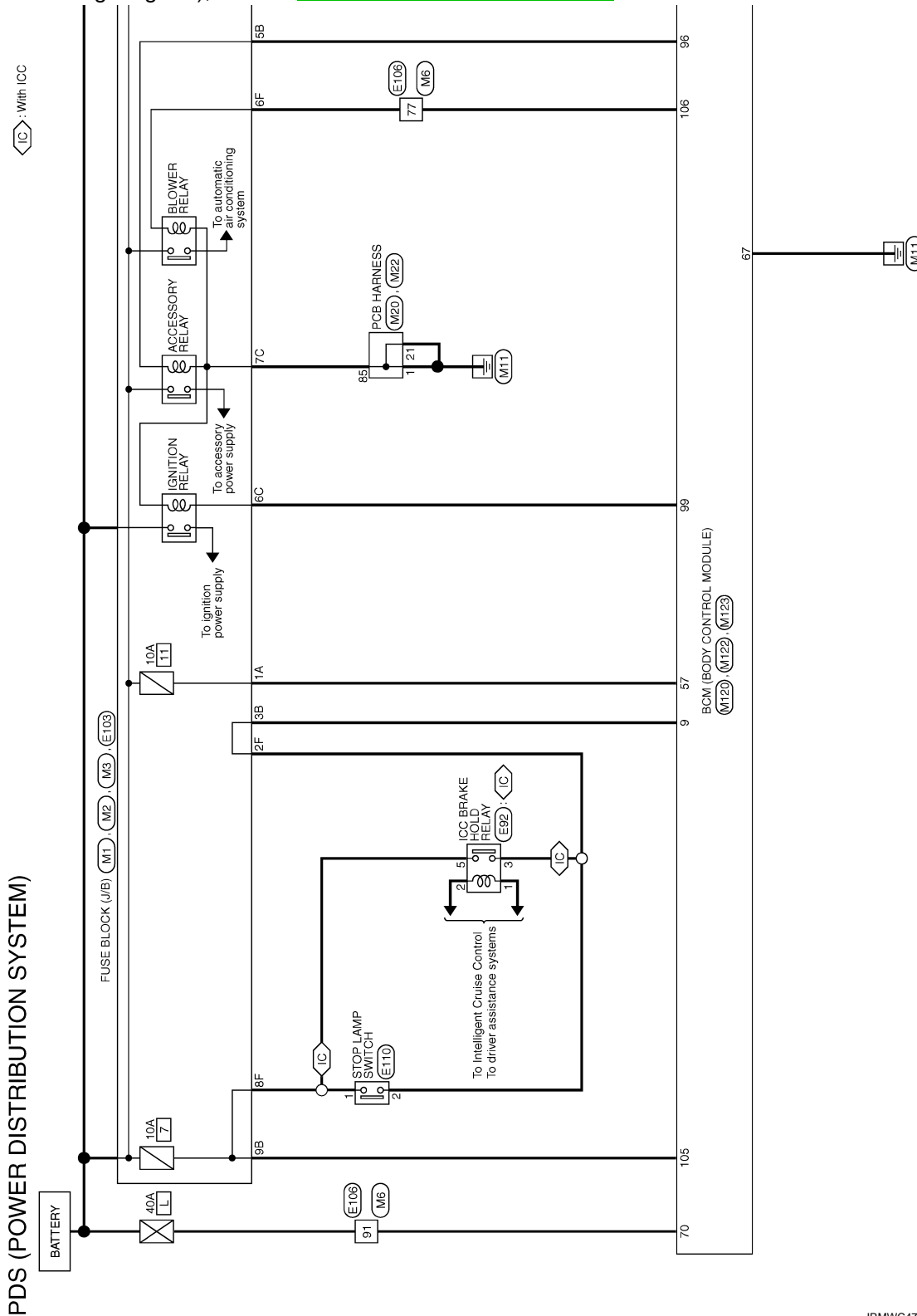

DIAGNOSIS AND REPAIR WORK FLOW

< BASIC INSPECTION >

[POWER DISTRIBUTION SYSTEM]

BASIC INSPECTION

DIAGNOSIS AND REPAIR WORK FLOW

Work Flow

INFOID:000000007798071

OVERALL SEQUENCE

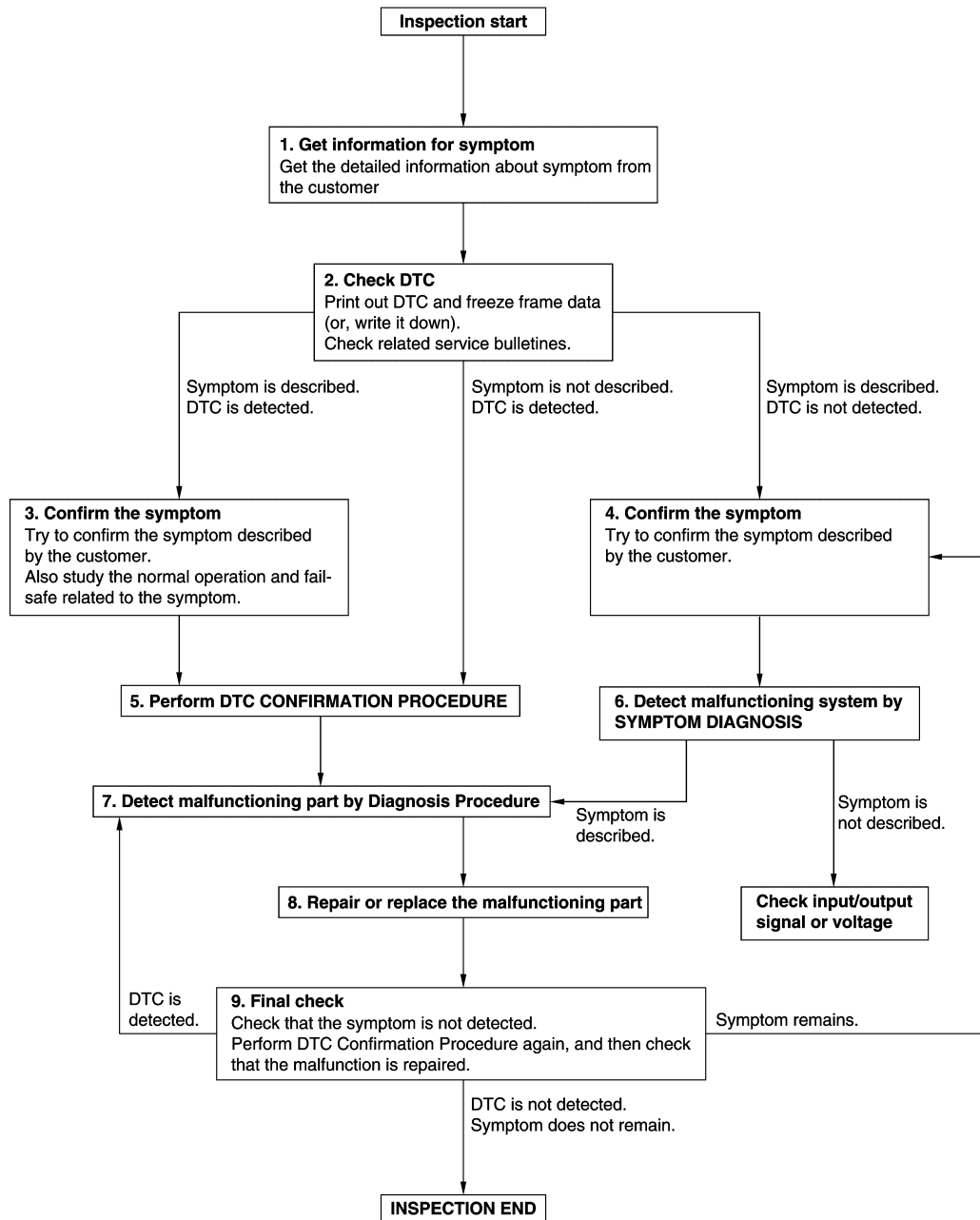

JMKIA8652GB

DETAILED FLOW

Revision: 2013 September

PCS-52

2012 M

DIAGNOSIS AND REPAIR WORK FLOW

[POWER DISTRIBUTION SYSTEM]

< BASIC INSPECTION >

1.GET INFORMATION FOR SYMPTOM

1. Get detailed information from the customer about the symptom (the condition and the environment when the incident/malfunction occurs).
2. Check operation condition of the function that is malfunctioning.

>> GO TO 2.

2.CHECK DTC

1. Check DTC.
2. Perform the following procedure if DTC is detected.
 - Record DTC and freeze frame data (Print them out using CONSULT.)
 - Erase DTC.
 - Study the relationship between the cause detected by DTC and the symptom described by the customer.
3. Check related service bulletins for information.

Are any symptoms described and any DTC detected?

Symptom is described, DTC is detected>>GO TO 3.

Symptom is described, DTC is not detected>>GO TO 4.

Symptom is not described, DTC is detected>>GO TO 5.

3.CONFIRM THE SYMPTOM

Try to confirm the symptom described by the customer.

Also study the normal operation and fail-safe related to the symptom.

Verify relation between the symptom and the condition when the symptom is detected.

>> GO TO 5.

4.CONFIRM THE SYMPTOM

Try to confirm the symptom described by the customer.

Verify relation between the symptom and the condition when the symptom is detected.

>> GO TO 6.

5.PERFORM DTC CONFIRMATION PROCEDURE

Perform DTC CONFIRMATION PROCEDURE for the detected DTC, and then check that DTC is detected again. At this time, always connect CONSULT to the vehicle, and check self diagnostic results in real time.

If two or more DTCs are detected, refer to [BCS-56. "DTC Inspection Priority Chart"](#), and determine trouble diagnosis order.

NOTE:

- Freeze frame data is useful if the DTC is not detected.
- Perform Component Function Check if DTC CONFIRMATION PROCEDURE is not included on Service Manual. This simplified check procedure is an effective alternative though DTC cannot be detected during this check.

If the result of Component Function Check is NG, it is the same as the detection of DTC by DTC CONFIRMATION PROCEDURE.

Is DTC detected?

YES >> GO TO 7.

NO >> Check according to [GI-44. "Intermittent Incident"](#).

6.DETECT MALFUNCTIONING SYSTEM BY SYMPTOM DIAGNOSIS

Detect malfunctioning system according to SYMPTOM DIAGNOSIS based on the confirmed symptom in step 4, and determine the trouble diagnosis order based on possible causes and symptom.

Is the symptom described?

YES >> GO TO 7.

NO >> Monitor input data from related sensors or check voltage of related module terminals using CONSULT.

7.DETECT MALFUNCTIONING PART BY DIAGNOSTIC PROCEDURE

A

B

C

D

E

F

G

H

I

J

K

L

PCS

N

O

P

DIAGNOSIS AND REPAIR WORK FLOW

[POWER DISTRIBUTION SYSTEM]

< BASIC INSPECTION >

Inspect according to Diagnostic Procedure of the system.

Is malfunctioning part detected?

YES >> GO TO 8.

NO >> Check according to [GI-44. "Intermittent Incident"](#).

8. REPAIR OR REPLACE THE MALFUNCTIONING PART

1. Repair or replace the malfunctioning part.
2. Reconnect parts or connectors disconnected during Diagnostic Procedure again after repair and replacement.
3. Check DTC. If DTC is detected, erase it.

>> GO TO 9.

9. FINAL CHECK

When DTC is detected in step 2, perform DTC CONFIRMATION PROCEDURE again, and then check that the malfunction is repaired securely.

When symptom is described by the customer, refer to confirmed symptom in step 3 or 4, and check that the symptom is not detected.

Is DTC detected and does symptom remain?

YES-1 >> DTC is detected: GO TO 7.

YES-2 >> Symptom remains: GO TO 4.

NO >> Before returning the vehicle to the customer, always erase DTC.

B2614 ACC RELAY CIRCUIT

< DTC/CIRCUIT DIAGNOSIS >

[POWER DISTRIBUTION SYSTEM]

DTC/CIRCUIT DIAGNOSIS

B2614 ACC RELAY CIRCUIT

DTC Logic

INFOID:0000000006887735

DTC DETECTION LOGIC

DTC No.	Trouble diagnosis name	DTC detecting condition	Possible cause
B2614	BCM	An immediate operation of accessory relay is requested by BCM, but there is no response for more than 2 second.	<ul style="list-style-type: none">• Harness or connectors (Accessory relay circuit is open or shorted)• BCM• Accessory relay

DTC CONFIRMATION PROCEDURE

1.PERFORM DTC CONFIRMATION PROCEDURE

1. Turn the power supply position to ACC under the following conditions, and wait for 2 second or more.
 - Selector lever is in the P position
 - Do not depress brake pedal
2. Check "Self-diagnosis result" of BCM with CONSULT.

Is DTC detected?

- YES >> Go to [PCS-55, "Diagnosis Procedure"](#).
NO >> INSPECTION END

Diagnosis Procedure

INFOID:0000000006887736

1.CHECK ACCESSORY RELAY POWER SUPPLY-1

1. Turn ignition switch OFF.
2. Disconnect accessory relay.
3. Check voltage between accessory relay harness connector and ground.

(+)	(-)	Condition	Voltage (V) (Approx.)	
Accessory relay Terminal				
1	Ground	Ignition switch	OFF	0
			ACC or ON	12

Is the inspection result normal?

- YES >> GO TO 3.
NO >> GO TO 2.

2.CHECK ACCESSORY RELAY POWER SUPPLY CIRCUIT

1. Turn ignition switch OFF.
2. Disconnect BCM connector.
3. Check continuity between accessory relay harness connector and BCM harness connector.

Accessory relay Terminal	BCM		Continuity
	Connector	Terminal	
1	M123	96	Existed

4. Check continuity between accessory relay harness connector and ground.

B2614 ACC RELAY CIRCUIT

< DTC/CIRCUIT DIAGNOSIS >

[POWER DISTRIBUTION SYSTEM]

Accessory relay	Ground	Continuity
Terminal		
1		Not existed

Is the inspection result normal?

- YES >> Replace BCM. Refer to [BCS-82, "Removal and Installation"](#).
NO >> Repair or replace harness.

3.CHECK ACCESSORY RELAY GROUND CIRCUIT

1. Turn ignition switch OFF.
2. Check continuity between accessory relay harness connector and ground.

Accessory relay	Ground	Continuity
Terminal		
2		Existed

Is the inspection result normal?

- YES >> GO TO 4.
NO >> Repair accessory relay ground circuit.

4.CHECK ACCESSORY RELAY POWER SUPPLY CIRCUIT-2

1. Turn ignition switch ACC.
2. Check voltage between accessory relay harness connector and ground.

(+)	(-)	Voltage (V) (Approx.)
Accessory relay		
Terminal		
5	Ground	Battery voltage

Is the inspection result normal?

- YES >> GO TO 5.
NO >> Check continuity open or short between accessory relay and battery.

5.CHECK ACCESSORY RELAY

Refer to [PCS-56, "Component Inspection"](#).

Is the inspection result normal?

- YES >> GO TO 6.
NO >> Replace accessory relay.

6.CHECK INTERMITTENT INCIDENT

Refer to [GI-44, "Intermittent Incident"](#).

>> INSPECTION END

Component Inspection

INFOID:000000006887737

1.CHECK ACCESSORY RELAY

1. Turn ignition switch OFF.
2. Remove accessory relay.

B2614 ACC RELAY CIRCUIT

[POWER DISTRIBUTION SYSTEM]

< DTC/CIRCUIT DIAGNOSIS >

3. Check the continuity between accessory relay terminals.

Terminals	Condition	Continuity
3 and 5	12 V direct current supply between terminals 1 and 2	Existed
	No current supply	Not existed

Is the inspection result normal?

YES >> INSPECTION END

NO >> Replace accessory relay

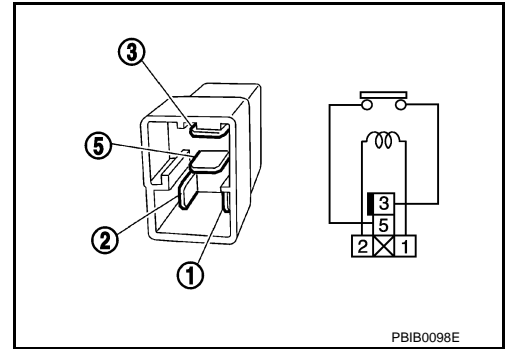

A
B
C
D
E
F
G
H
I
J
K
L
N
O
P

PCS

B2615 BLOWER RELAY CIRCUIT

< DTC/CIRCUIT DIAGNOSIS >

[POWER DISTRIBUTION SYSTEM]

B2615 BLOWER RELAY CIRCUIT

DTC Logic

INFOID:000000006887738

DTC DETECTION LOGIC

DTC No.	Trouble diagnosis name	DTC detecting condition	Possible cause
B2615	BCM	BCM detects a difference of signal for 1 second or more between the following items. <ul style="list-style-type: none"> Blower relay ON/OFF request Blower relay feedback 	<ul style="list-style-type: none"> Harness or connectors (Blower relay circuit is open or shorted) BCM Blower relay

DTC CONFIRMATION PROCEDURE

1. PERFORM DTC CONFIRMATION PROCEDURE

- Turn ignition switch ON under the following conditions, and wait for 1 second or more.
 - Selector lever is in the P position
 - Do not depress brake pedal
- Check "Self-diagnosis result" of BCM with CONSULT.

Is DTC detected?

- YES >> Go to [PCS-58. "Diagnosis Procedure"](#).
NO >> INSPECTION END

Diagnosis Procedure

INFOID:000000006887739

1. CHECK BLOWER RELAY POWER SUPPLY

- Turn ignition switch OFF.
- Disconnect blower relay.
- Check voltage between blower relay harness connector and ground.

(+)	(-)	Condition	Voltage (V) (Approx.)
Blower relay Terminal			
1	Ground	Ignition switch	OFF or ACC
			ON
			0
			Battery voltage

Is the inspection result normal?

- YES >> GO TO 3.
NO >> GO TO 2.

2. CHECK BLOWER RELAY POWER SUPPLY CIRCUIT

- Turn ignition switch OFF.
- Disconnect BCM connector.
- Check continuity between blower relay harness connector and BCM harness connector.

Blower relay Terminal	BCM		Continuity
	Connector	Terminal	
1	M123	106	Existed

- Check continuity between blower relay harness connector and ground.

Blower relay Terminal	Ground	Continuity
1		
		Not existed

Is the inspection result normal?

B2615 BLOWER RELAY CIRCUIT

[POWER DISTRIBUTION SYSTEM]

< DTC/CIRCUIT DIAGNOSIS >

- YES >> GO TO 6.
 NO >> Repair or replace harness.

3.CHECK BLOWER RELAY GROUND CIRCUIT

1. Turn ignition switch OFF.
2. Check continuity between blower relay harness connector and ground.

Blower relay	Ground	Continuity
Terminal		Existed
2		

Is the inspection result normal?

- YES >> GO TO 4.
 NO >> Repair blower relay ground circuit.

4.CHECK BLOWER RELAY POWER SUPPLY CIRCUIT-2

1. Turn ignition switch ON.
2. Check voltage between blower relay harness connector and ground.

(+)	(-)	Voltage (V) (Approx.)
Blower relay		Battery voltage
Terminal		
5	Ground	

Is the inspection result normal?

- YES >> GO TO 5.
 NO >> Check continuity open or short between blower relay and battery.

5.CHECK BLOWER RELAY

Refer to [PCS-59, "Component Inspection"](#).

Is the inspection result normal?

- YES >> GO TO 6.
 NO >> Replace blower relay.

6.CHECK INTERMITTENT INCIDENT

Refer to [GI-44, "Intermittent Incident"](#).

>> INSPECTION END

Component Inspection

INFOID:000000006887740

PCS

1.CHECK BLOWER RELAY

1. Turn ignition switch OFF.
2. Remove blower relay.
3. Check the continuity between blower relay terminals.

Terminals	Condition	Continuity
3 and 5	12 V direct current supply between terminals 1 and 2	Existed
	No current supply	Not existed

Is the inspection result normal?

- YES >> INSPECTION END
 NO >> Replace blower relay

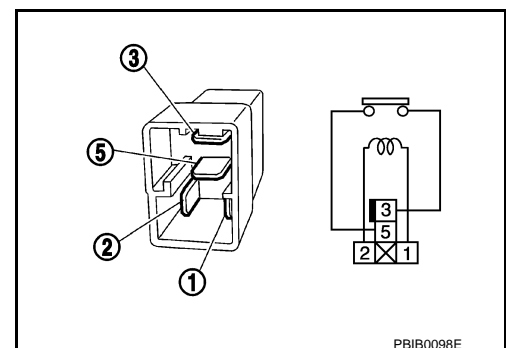

PBIB0098E

B2616 IGNITION RELAY CIRCUIT

< DTC/CIRCUIT DIAGNOSIS >

[POWER DISTRIBUTION SYSTEM]

B2616 IGNITION RELAY CIRCUIT

DTC Logic

INFOID:000000006887741

DTC DETECTION LOGIC

DTC No.	Trouble diagnosis name	DTC detecting condition	Possible cause
B2616	BCM	An immediate operation of ignition relay is requested by BCM, but there is no response for more than 1 second	<ul style="list-style-type: none"> • Harness or connectors (Ignition relay circuit is open or shorted) • BCM • Ignition relay

DTC CONFIRMATION PROCEDURE

1. PERFORM DTC CONFIRMATION PROCEDURE

- Turn ignition switch ON under the following conditions, and wait for 1 second or more.
 - Selector lever is in the P position
 - Do not depress brake pedal
- Check "Self-diagnosis result" with CONSULT.

Is DTC detected?

- YES >> Go to [PCS-60. "Diagnosis Procedure"](#).
 NO >> INSPECTION END

Diagnosis Procedure

INFOID:000000006887742

1. CHECK IGNITION RELAY POWER SUPPLY

- Turn ignition switch OFF.
- Disconnect ignition relay.
- Check voltage between ignition relay harness connector and ground.

(+)	(-)	Condition	Voltage (V) (Approx.)
Ignition relay Terminal			
2	Ground	Ignition switch	OFF or ACC
			ON
			0
			Battery voltage

Is the inspection result normal?

- YES >> GO TO 3.
 NO >> GO TO 2.

2. CHECK IGNITION RELAY POWER SUPPLY CIRCUIT

- Turn ignition switch OFF.
- Disconnect BCM connector.
- Check continuity between ignition relay harness connector and BCM harness connector.

Ignition relay Terminal	BCM		Continuity
	Connector	Terminal	
2	M123	99	Existed

- Check continuity between ignition relay harness connector and ground.

Ignition relay Terminal	Ground	Continuity
2		
		Not existed

Is the inspection result normal?

B2616 IGNITION RELAY CIRCUIT

[POWER DISTRIBUTION SYSTEM]

< DTC/CIRCUIT DIAGNOSIS >

- YES >> Replace BCM. Refer to [BCS-82, "Removal and Installation"](#).
 NO >> Repair or replace harness.

3.CHECK IGNITION RELAY GROUND CIRCUIT

- Turn ignition switch OFF.
- Check continuity between ignition relay harness connector and ground.

Ignition relay	Ground	Continuity
Terminal		
1		Existed

Is the inspection result normal?

- YES >> GO TO 4.
 NO >> Repair ignition relay ground circuit.

4.CHECK IGNITION RELAY POWER SUPPLY CIRCUIT-2

- Turn ignition switch ON.
- Check voltage between ignition relay harness connector and ground.

(+)	(-)	Voltage (V) (Approx.)
Ignition relay		
Terminal		
5	Ground	Battery voltage

Is the inspection result normal?

- YES >> GO TO 5.
 NO >> Check continuity open or short between ignition relay and battery.

5.CHECK IGNITION RELAY

Refer to [PCS-61, "Component Inspection"](#).

Is the inspection result normal?

- YES >> GO TO 6.
 NO >> Replace ignition relay.

6.CHECK INTERMITTENT INCIDENT

Refer to [GI-44, "Intermittent Incident"](#).

>> INSPECTION END

Component Inspection

INFOID:000000006887743

PCS

1.CHECK IGNITION RELAY

- Turn ignition switch OFF.
- Remove ignition relay.
- Check the continuity between ignition relay terminals.

Terminals	Condition	Continuity
3 and 5	12 V direct current supply between terminals 1 and 2	Existed
	No current supply	Not existed

Is the inspection result normal?

- YES >> INSPECTION END
 NO >> Replace Ignition relay

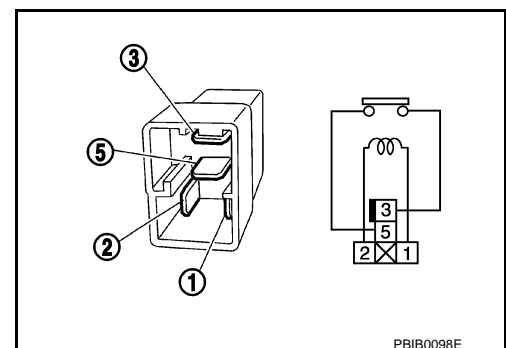

PBIB0098E

B2618 BCM

DTC Logic

INFOID:000000006887744

DTC DETECTION LOGIC

NOTE:

- If DTC B2618 is displayed with DTC U1000, first perform the trouble diagnosis for DTC U1000. Refer to [BCS-70, "DTC Logic"](#).
- If DTC B2618 is displayed with DTC U1010, first perform the trouble diagnosis for DTC U1010. Refer to [BCS-71, "DTC Logic"](#).

DTC No.	Trouble diagnosis name	DTC detecting condition	Possible cause
B2618	BCM	An immediate operation of ignition relay (IPDM E/R) is requested by BCM, but there is no response for more than 1 second	BCM

DTC CONFIRMATION PROCEDURE

1. PERFORM DTC CONFIRMATION PROCEDURE

1. Turn ignition switch ON under the following conditions, and wait for 1 second or more.
 - Selector lever is in the P or N position
 - Do not depress brake pedal
2. Check "Self-diagnosis result" of BCM with CONSULT.

Is DTC detected?

- YES >> Go to [PCS-62, "Diagnosis Procedure"](#).
 NO >> INSPECTION END

Diagnosis Procedure

INFOID:000000006887745

1. INSPECTION START

1. Turn ignition switch ON.
2. Select "Self-diagnosis result" of BCM with CONSULT.
3. Touch "ERASE".
4. Perform DTC Confirmation Procedure.
See [PCS-62, "DTC Logic"](#).

Is the 1st trip DTC B2618 displayed again?

- YES >> Replace BCM. Refer to [BCS-82, "Removal and Installation"](#)
 NO >> INSPECTION END

B261A PUSH-BUTTON IGNITION SWITCH

< DTC/CIRCUIT DIAGNOSIS >

[POWER DISTRIBUTION SYSTEM]

B261A PUSH-BUTTON IGNITION SWITCH

DTC Logic

INFOID:000000006887746

DTC DETECTION LOGIC

NOTE:

- If DTC B261A is displayed with DTC U1000, first perform the trouble diagnosis for DTC U1000. Refer to [BCS-70, "DTC Logic"](#).
- If DTC B261A is displayed with DTC U1010, first perform the trouble diagnosis for DTC U1010. Refer to [BCS-71, "DTC Logic"](#).

DTC No.	Trouble diagnosis name	DTC detecting condition	Possible cause
B261A	PUSH-BTN IGN SW	BCM detects a difference of signal for 1 second or more between the following items. <ul style="list-style-type: none"> • Push-button ignition switch signal • Push-button ignition switch status signal (CAN) 	<ul style="list-style-type: none"> • Harness or connectors (Push-button ignition switch circuit is open or shorted.) • BCM • IPDM E/R

DTC CONFIRMATION PROCEDURE

1. PERFORM DTC CONFIRMATION PROCEDURE

1. Press the push-button ignition switch under the following conditions, and wait for 1 second or more.
 - Selector lever is in the P or N position
 - Do not depress brake pedal
2. Check "Self-diagnosis result" of BCM with CONSULT.

Is DTC detected?

- YES >> Go to [PCS-63, "Diagnosis Procedure"](#).
 NO >> INSPECTION END

Diagnosis Procedure

INFOID:000000006887747

1. CHECK IGNITION SWITCH OUTPUT SIGNAL (PUSH-BUTTON IGNITION SWITCH)

1. Disconnect push-button ignition switch connector and IPDM E/R connector.
2. Check voltage between push-button ignition switch harness connector and ground.

(+)		(-)	Voltage (V) (Approx.)
Push-button ignition switch			
Connector	Terminal	Ground	12
M50	4		

Is the inspection result normal?

- YES >> GO TO 3.
 NO >> GO TO 2.

2. CHECK PUSH-BUTTON IGNITION SWITCH CIRCUIT (BCM)

1. Disconnect BCM connector.
2. Check continuity between BCM harness connector and push-button ignition switch harness connector.

BCM		Push-button ignition switch		Continuity
Connector	Terminal	Connector	Terminal	
M123	100	M50	4	Existed

3. Check continuity between push-button ignition switch harness connector and ground.

Push-button ignition switch		Ground	Continuity
Connector	Terminal		
M50	4		Not existed

B261A PUSH-BUTTON IGNITION SWITCH

[POWER DISTRIBUTION SYSTEM]

< DTC/CIRCUIT DIAGNOSIS >

Is the inspection result normal?

YES >> Replace BCM. Refer to [BCS-82. "Removal and Installation"](#).

NO >> Repair or replace harness.

3. CHECK IGNITION SWITCH OUTPUT SIGNAL (IPDM E/R)

Check voltage between IPDM E/R harness connector and ground.

(+)		(-)	Voltage (V) (Approx.)
IPDM E/R			
Connector	Terminal		
E5	30	Ground	12

Is the inspection result normal?

YES >> Replace IPDM E/R.

NO >> GO TO 4.

4. CHECK PUSH-BUTTON IGNITION SWITCH CIRCUIT (IPDM E/R)

1. Disconnect IPDM E/R connector.
2. Check continuity between IPDM E/R harness connector and push-button ignition switch harness connector.

IPDM E/R		Push-button ignition switch		Continuity
Connector	Terminal	Connector	Terminal	
E5	30	M50	4	Existed

3. Check continuity between push-button ignition switch harness connector and ground.

Push-button ignition switch		Ground	Continuity
Connector	Terminal		
M50	4		Not existed

Is the inspection result normal?

YES >> GO TO 5.

NO >> Repair or replace harness.

5. CHECK INTERMITTENT INCIDENT

Refer to [GI-44. "Intermittent Incident"](#).

>> INSPECTION END

B26F1 IGNITION RELAY

< DTC/CIRCUIT DIAGNOSIS >

[POWER DISTRIBUTION SYSTEM]

B26F1 IGNITION RELAY

DTC Logic

INFOID:000000006887748

DTC DETECTION LOGIC

DTC No.	Trouble diagnosis name	DTC detecting condition	Possible cause
B26F1	IGN RELAY OFF	BCM transmits the ignition relay control signal (ON: 0 V) or ignition switch ON signal (ON) (CAN), but does not receives ignition switch ON signal (ON) (CAN) from IPDM E/R.	<ul style="list-style-type: none"> Harness or connectors (ignition relay circuit is open) BCM IPDM E/R

DTC CONFIRMATION PROCEDURE

1. PERFORM DTC CONFIRMATION PROCEDURE

- Turn ignition switch ON under the following conditions, and wait for 2 seconds or more.
 - Selector lever is in the P or N position
 - Do not depress brake pedal
- Check "Self-diagnosis result" with CONSULT.

Is DTC detected?

- YES >> Go to [PCS-65. "Diagnosis Procedure"](#).
 NO >> INSPECTION END

Diagnosis Procedure

INFOID:000000006887749

1. CHECK IPDM E/R SELF-DIAGNOSTIC RESULT

- Turn ignition switch ON.
- Erase the DTC of IPDM E/R.
- Turn ignition switch OFF.
- Turn ignition switch ON and check the DTC again.

Is DTC detected?

- YES >> Repair or replace the malfunctioning part. Refer to [PCS-25. "DTC Index"](#).
 NO >> GO TO 2.

2. CHECK IGNITION RELAY (IPDM E/R) CONTROL SIGNAL

Check voltage between BCM harness connector and ground.

(+)		(-)	Condition		Voltage (V) (Approx.)
BCM					
Connector	Terminal	Ground	Ignition switch	ON	0
M123	98				

Is the inspection result normal?

- YES >> GO TO 3.
 NO >> Replace BCM. Refer to [BCS-82. "Removal and Installation"](#).

3. CHECK IGNITION RELAY (IPDM E/R) CONTROL SIGNAL CIRCUIT

- Turn ignition switch OFF.
- Disconnect BCM and IPDM connectors.
- Check continuity between BCM harness connector and IPDM E/R harness connector.

BCM		IPDM E/R		Continuity
Connector	Terminal	Connector	Terminal	
M123	98	E5	18	Existed

Is the inspection result normal?

- YES >> Replace IPDM E/R.

B26F1 IGNITION RELAY

< DTC/CIRCUIT DIAGNOSIS >

[POWER DISTRIBUTION SYSTEM]

NO >> Repair or replace harness.

B26F2 IGNITION RELAY

< DTC/CIRCUIT DIAGNOSIS >

[POWER DISTRIBUTION SYSTEM]

B26F2 IGNITION RELAY

DTC Logic

INFOID:000000006887750

DTC DETECTION LOGIC

DTC No.	Trouble diagnosis name	DTC detecting condition	Possible cause
B26F2	IGN RELAY ON	BCM transmits the ignition relay control signal (OFF: 12 V) or ignition switch ON signal (OFF) (CAN), but does not receives ignition switch ON signal (OFF) (CAN) from IPDM E/R.	<ul style="list-style-type: none"> • Harness or connectors (ignition relay circuit is short) • BCM • IPDM E/R

DTC CONFIRMATION PROCEDURE

1. PERFORM DTC CONFIRMATION PROCEDURE

1. Turn ignition switch ON under the following conditions, and wait for 2 seconds or more.
 - Selector lever is in the P or N position
 - Do not depress brake pedal
2. Check "Self-diagnosis result" with CONSULT.

Is DTC detected?

- YES >> Go to [PCS-67. "Diagnosis Procedure"](#).
 NO >> INSPECTION END

Diagnosis Procedure

INFOID:000000006887751

1. CHECK IPDM E/R SELF-DIAGNOSTIC RESULT

1. Turn ignition switch ON.
2. Erase the DTC of IPDM E/R.
3. Turn ignition switch OFF.
4. Turn ignition switch ON and check the DTC again.

Is DTC detected?

- YES >> Repair or replace the malfunctioning part. Refer to [PCS-25. "DTC Index"](#).
 NO >> GO TO 2.

2. CHECK IGNITION RELAY (IPDM E/R) CONTROL SIGNAL

1. Turn ignition switch OFF.
2. Check voltage between IPDM E/R harness connector and ground.

(+)		(-)	Condition		Voltage (V) (Approx.)
IPDM E/R					
Connector	Terminal	Ground	Ignition switch	OFF or ACC	12
E5	18				

PCS

Is the inspection result normal?

- YES >> Replace IPDM E/R.
 NO >> GO TO 3.

3. CHECK IGNITION RELAY (IPDM E/R) CONTROL SIGNAL CIRCUIT - 1

1. Disconnect BCM and IPDM E/R connectors.
2. Check continuity between IPDM E/R harness connector and ground.

IPDM E/R		Ground	Continuity
Connector	Terminal		
E5	18		Not existed

Is the inspection result normal?

- YES >> GO TO 4.

B26F2 IGNITION RELAY

< DTC/CIRCUIT DIAGNOSIS >

[POWER DISTRIBUTION SYSTEM]

NO >> Repair or replace harness.

4. CHECK IGNITION RELAY (IPDM E/R) CONTROL SIGNAL CIRCUIT - 2

1. Connect IPDM E/R connectors.
2. Check voltage between IPDM E/R harness connector and ground.

(+)		(-)	Condition		Voltage (V) (Approx.)
IPDM E/R					
Connector	Terminal				
E5	18	Ground	Ignition switch	OFF or ACC	12

Is the inspection result normal?

- YES >> Replace BCM. Refer to [BCS-82. "Removal and Installation"](#).
NO >> Replace IPDM E/R.

B26F6 BCM

DTC Logic

INFOID:000000006887752

DTC DETECTION LOGIC

NOTE:

- If DTC B26F6 is displayed with DTC U1000, first perform the trouble diagnosis for DTC U1000. Refer to [BCS-70, "DTC Logic"](#).
- If DTC B26F6 is displayed with DTC U1010, first perform the trouble diagnosis for DTC U1010. Refer to [BCS-71, "DTC Logic"](#).

DTC No.	Trouble diagnosis name	DTC detecting condition	Possible cause
B26F6	BCM	Ignition relay ON signal is not transmitted from IPDM E/R when BCM turns ignition relay ON.	BCM

DTC CONFIRMATION PROCEDURE

1. PERFORM DTC CONFIRMATION PROCEDURE

1. Turn ignition switch ON under the following conditions, and wait for 1 second or more.
 - Selector lever is in the P or N position
 - Do not depress brake pedal
2. Check "Self-diagnosis result" of BCM with CONSULT.

Is DTC detected?

- YES >> Go to [PCS-69, "Diagnosis Procedure"](#).
- NO >> INSPECTION END

Diagnosis Procedure

INFOID:000000006887753

1. INSPECTION START

1. Turn ignition switch ON.
2. Select "Self-diagnosis result" of BCM with CONSULT.
3. Touch "ERASE".
4. Perform DTC Confirmation Procedure.
See [PCS-69, "DTC Logic"](#).

Is DTC detected?

- YES >> Replace BCM. Refer to [BCS-82, "Removal and Installation"](#)
- NO >> INSPECTION END

PCS

PUSH-BUTTON IGNITION SWITCH

< DTC/CIRCUIT DIAGNOSIS >

[POWER DISTRIBUTION SYSTEM]

PUSH-BUTTON IGNITION SWITCH

Component Function Check

INFOID:000000006887754

1.CHECK FUNCTION

1. Select "PUSH SW" in "Data Monitor" mode with CONSULT.
2. Check the push-button ignition switch signal under the following conditions.

Test item	Condition	Status
PUSH SW	Push-button ignition switch is pressed	ON
	Push-button ignition switch is not pressed	OFF

Is the indication normal?

- YES >> INSPECTION END.
NO >> Go to [PCS-70. "Diagnosis Procedure"](#).

Diagnosis Procedure

INFOID:000000006887755

1.CHECK PUSH-BUTTON IGNITION SWITCH OUTPUT SIGNAL 1

1. Turn ignition switch OFF.
2. Disconnect push-button ignition switch connector and IPDM E/R connector.
3. Check voltage between push-button ignition switch harness connector and ground.

(+)		(-)	Voltage (V) (Approx.)
Connector	Terminal		
M50	4	Ground	Battery voltage

Is the inspection result normal?

- YES >> GO TO 3.
NO >> GO TO 2.

2.CHECK PUSH-BUTTON IGNITION SWITCH CIRCUIT 1

1. Disconnect BCM connector.
2. Check continuity between BCM harness connector and push-button ignition switch harness connector.

BCM		Push-button ignition switch		Continuity
Connector	Terminal	Connector	Terminal	
M123	100	M50	4	Existed

3. Check continuity between BCM harness connector and ground.

BCM		Ground	Continuity
Connector	Terminal		
M123	100		Not existed

Is the inspection result normal?

- YES >> Replace BCM. Refer to [BCS-82. "Removal and Installation"](#).
NO >> Repair or replace harness.

3.CHECK PUSH-BUTTON IGNITION SWITCH OUTPUT SIGNAL 2

Check voltage between IPDM E/R harness connector and ground.

PUSH-BUTTON IGNITION SWITCH

< DTC/CIRCUIT DIAGNOSIS >

[POWER DISTRIBUTION SYSTEM]

(+)		(-)	Voltage (V) (Approx.)
IPDM E/R			
Connector	Terminal		
E5	30	Ground	Battery voltage

Is the inspection result normal?

YES >> GO TO 5.

NO >> GO TO 4.

4.CHECK PUSH-BUTTON IGNITION SWITCH CIRCUIT 2

1. Disconnect BCM connector.
2. Check continuity between IPDM E/R harness connector and push-button ignition switch harness connector.

IPDM E/R		Push-button ignition switch		Continuity
Connector	Terminal	Connector	Terminal	
E5	30	M50	4	Existed

3. Check continuity between IPDM E/R harness connector and ground.

IPDM E/R		Ground	Continuity
Connector	Terminal		
E5	30		Not existed

Is the inspection result normal?

YES >> Replace IPDM E/R.

NO >> Repair or replace harness.

5.CHECK PUSH-BUTTON IGNITION SWITCH GROUND CIRCUIT

Check continuity between push-button ignition switch harness connector and ground.

Push-button ignition switch		Ground	Continuity
Connector	Terminal		
M50	1		Existed

Is the inspection result normal?

YES >> GO TO 6.

NO >> Repair or replace harness.

6.CHECK PUSH-BUTTON IGNITION SWITCH

Refer to [PCS-71, "Component Inspection"](#).

Is the inspection result normal?

YES >> GO TO 7.

NO >> Replace push-button ignition switch.

7.CHECK INTERMITTENT INCIDENT

Refer to [GI-44, "Intermittent Incident"](#).

>> INSPECTION END

Component Inspection

INFOID:000000006887756

1.CHECK PUSH-BUTTON IGNITION SWITCH

1. Turn ignition switch OFF.
2. Disconnect push-button ignition switch connector.
3. Check continuity between push-button ignition switch terminals.

PUSH-BUTTON IGNITION SWITCH

< DTC/CIRCUIT DIAGNOSIS >

[POWER DISTRIBUTION SYSTEM]

Push-button ignition switch		Condition	Continuity
Terminal			
4	1	Pressed	Existed
		Not pressed	Not existed

Is the inspection result normal?

YES >> INSPECTION END

NO >> Replace push-button ignition switch.

PUSH-BUTTON IGNITION SWITCH POSITION INDICATOR

< DTC/CIRCUIT DIAGNOSIS >

[POWER DISTRIBUTION SYSTEM]

PUSH-BUTTON IGNITION SWITCH POSITION INDICATOR

Description

INFOID:000000006887757

Push-button ignition switch changes the power supply position.
BCM maintains the power supply position status.
BCM changes the power supply position with the operation of the push-button ignition switch.

Component Function Check

INFOID:000000006887758

1.CHECK FUNCTION

Check push-button ignition switch ("LOCK INDICATOR", "ACC INDICATOR" and "IGNITION ON IND") in Active Test Mode with CONSULT.

Test item		Description	
LOCK INDICATOR ACC INDICATOR IGNITION ON IND	ON	Position indicator	Illuminates
	OFF		Does not illuminate

Is the inspection result normal?

- YES >> INSPECTION END.
NO >> Refer to [PCS-73, "Diagnosis Procedure"](#).

Diagnosis Procedure

INFOID:000000006887759

1.CHECK PUSH-BUTTON IGNITION SWITCH INPUT SIGNAL

- Turn ignition switch OFF.
- Disconnect push-button ignition switch connector.
- Check voltage between push-button ignition switch harness connector and ground.

(+)		(-)	Voltage (V) (Approx.)
Push-button ignition switch			
Connector	Terminal	Ground	Battery voltage
M50	8		

Is the inspection normal?

- YES >> GO TO 2.
NO-1 >> Check 10 A fuse [No.9, located in fuse block (J/B)].
NO-2 >> Check harness for open or short between push-button ignition switch and fuse.

2.CHECK BCM INPUT

- Connect push-button ignition switch connector.
- Disconnect BCM connector.
- Check voltage between BCM connector and ground.

(+)		(-)	Voltage (V) (Approx.)
BCM			
Connector	Terminal	Ground	Battery voltage
M123	73		
	91		
	109		

Is the inspection normal?

- YES >> Replace BCM. Refer to [BCS-82, "Removal and Installation"](#).
NO >> GO TO 3.

3.CHECK PUSH-BUTTON IGNITION SWITCH CIRCUIT

- Disconnect push-button ignition switch connector.

A
B
C
D
E
F
G
H
I
J
K
L
N
O
P

PCS

PUSH-BUTTON IGNITION SWITCH POSITION INDICATOR

< DTC/CIRCUIT DIAGNOSIS >

[POWER DISTRIBUTION SYSTEM]

2. Check continuity between BCM harness connector and push-button ignition switch harness connector.

Indicator	BCM		Push-button ignition switch		Continuity
	Connector	Terminal	Connector	Terminal	
LOCK	M123	91	M50	5	Existed
ACC		109		6	
ON		73		7	

3. Check continuity between BCM harness connector and ground.

Indicator	BCM		Ground	Continuity
	Connector	Terminal		
LOCK	M123	91		Not existed
ACC		109		
ON		73		

Is the inspection normal?

- YES >> Replace push-button ignition switch.
NO >> Repair or replace harness.

PUSH-BUTTON IGNITION SWITCH DOES NOT OPERATE

< SYMPTOM DIAGNOSIS >

[POWER DISTRIBUTION SYSTEM]

SYMPTOM DIAGNOSIS

PUSH-BUTTON IGNITION SWITCH DOES NOT OPERATE

Description

INFOID:000000006887760

Check that vehicle is under the condition shown in “Conditions of vehicle” before starting diagnosis, and check each symptom.

NOTE:

The engine start function, door lock function, power distribution system, and NATS-IVIS/NVIS in the Intelligent Key system are closely related to each other regarding control. The vehicle security function can operate only when the door lock and power distribution system are operating normally.

Conditions of Vehicle (Operating Conditions)

- “ENGINE START BY I-KEY” in “WORK SUPPORT” is ON when setting on CONSULT.
- One or more of Intelligent Keys with registered Intelligent Key ID is in the vehicle.

Diagnosis Procedure

INFOID:000000006887761

1.PERFORM WORK SUPPORT

Perform “INSIDE ANT DIAGNOSIS” on Work Support of “INTELLIGENT KEY”.
Refer to [DLK-32, "DOOR LOCK : CONSULT Function \(BCM - DOOR LOCK\)"](#).

>> GO TO 2.

2.PERFORM SELF-DIAGNOSIS RESULT

Perform Self-Diagnosis Result of “BCM”.

Is DTC detected?

- YES >> Refer to [BCS-57, "DTC Index"](#).
- NO >> GO TO 3.

3.CHECK PUSH-BUTTON IGNITION SWITCH

Check push-button ignition switch.

Refer to [PCS-70, "Component Function Check"](#).

Is the operation normal?

- YES >> GO TO 4.
- NO >> Repair or replace malfunctioning parts.

4.CONFIRM THE OPERATION

Confirm the operation again.

Is the inspection normal?

- YES >> Check intermittent incident. Refer to [GI-44, "Intermittent Incident"](#).
- NO >> GO TO 1.

A
B
C
D
E
F
G
H
I
J
K
L
N
O
P

PCS

PUSH-BUTTON IGNITION SWITCH POSITION INDICATOR DOES NOT ILLUMINATE

< SYMPTOM DIAGNOSIS >

[POWER DISTRIBUTION SYSTEM]

PUSH-BUTTON IGNITION SWITCH POSITION INDICATOR DOES NOT ILLUMINATE

Description

INFOID:000000006887762

- Before performing the diagnosis in the following table, check "Work Flow". Refer to [PCS-52, "Work Flow"](#).
- Check that vehicle is under the condition shown in "Conditions of vehicle" before starting diagnosis, and check each symptom.

Conditions of Vehicle (Operating Conditions)

- "ENGINE START BY I-KEY" in "WORK SUPPORT" is ON when setting on CONSULT.
- One or more of Intelligent Keys with registered Intelligent Key ID is in the vehicle.

Diagnosis Procedure

INFOID:000000006887763

1. CHECK PUSH-BUTTON IGNITION SWITCH INDICATOR

Check push-button ignition switch indicator.

Refer to [PCS-73, "Component Function Check"](#).

Is the inspection result normal?

YES >> GO TO 2.

NO >> Repair or replace the malfunctioning parts.

2. CONFIRM THE OPERATION

Confirm the operation again.

Is the result normal?

YES >> Check intermittent incident. Refer to [GI-44, "Intermittent Incident"](#).

NO >> GO TO 1.

PUSH-BUTTON IGNITION SWITCH

< REMOVAL AND INSTALLATION >

[POWER DISTRIBUTION SYSTEM]

REMOVAL AND INSTALLATION

PUSH-BUTTON IGNITION SWITCH

Exploded View

INFOID:000000007215655

Refer to [IP-12, "Exploded View"](#).

Removal and Installation

INFOID:000000007215656

REMOVAL

1. Remove front body side welt. Refer to [INT-35, "BODY SIDE WELT : Removal and Installation"](#).
2. Remove instrument side finisher LH. Refer to [IP-13, "Removal and Installation"](#).
3. Remove instrument lower panel LH. Refer to [IP-13, "Removal and Installation"](#).
4. Disconnect NATS antenna amp. connector and push-button ignition switch connector.
5. Disengage the NATS antenna amp. fixing pawls while pushing NATS antenna amp. from its back side, so that NATS antenna amp. and push-button ignition switch are lifted up from instrument panel assembly.

 : Pawl

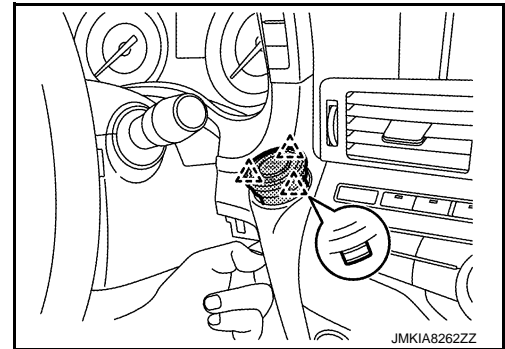

6. While pushing the push-button ignition switch from its back side, disengage the push-button ignition switch fixing pawls using a minus driver etc., and then remove push-button ignition switch.

 : Pawl

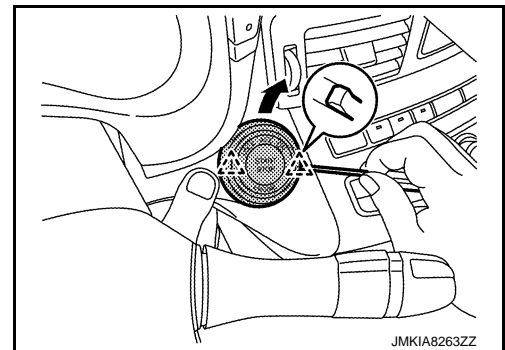

INSTALLATION

Install in the reverse order of removal.

A

B

C

D

E

F

G

H

I

J

K

L

PCS

N

O

P