

WT  
**SECTION**  
**ROAD WHEELS & TIRES**

A  
B  
C  
D

WT

**CONTENTS**

<b>PRECAUTION</b> .....	<b>WIRING DIAGRAM</b> .....	F
<b>PRECAUTIONS</b> .....	<b>TIRE PRESSURE MONITORING SYSTEM</b> .....	G
Precaution for Supplemental Restraint System (SRS) "AIR BAG" and "SEAT BELT PRE-TENSIONER" .....	Wiring Diagram .....	
Precautions Necessary for Steering Wheel Rotation After Battery Disconnection .....	<b>BASIC INSPECTION</b> .....	H
Service Notice and Precautions for TPMS .....	<b>DIAGNOSIS AND REPAIR WORK FLOW</b> .....	I
Service Notice and Precautions for Road Wheel .....	Work Flow .....	J
<b>PREPARATION</b> .....	<b>ADDITIONAL SERVICE WHEN REPLACING LOW TIRE PRESSURE WARNING CONTROL UNIT</b> .....	K
<b>PREPARATION</b> .....	Description .....	L
Special Service Tools .....	Work Procedure .....	M
Commercial Service Tools .....	<b>TIRE PRESSURE SENSOR WAKE UP OPERATION</b> .....	N
<b>SYSTEM DESCRIPTION</b> .....	Description .....	O
<b>COMPONENT PARTS</b> .....	Work Procedure .....	P
Component Parts Location .....	<b>ID REGISTRATION</b> .....	
Component Description .....	Description .....	
Low Tire Pressure Warning Control Unit .....	Work Procedure .....	
Tire Pressure Sensor .....	<b>DTC/CIRCUIT DIAGNOSIS</b> .....	
Tire Pressure Receiver .....	<b>C1704, C1705, C1706, C1707 LOW TIRE PRESSURE</b> .....	
Information Display .....	DTC Logic .....	
<b>SYSTEM</b> .....	Diagnosis Procedure .....	
System Description .....	<b>C1708, C1709, C1710, C1711 TIRE PRESSURE SENSOR</b> .....	
<b>DIAGNOSIS SYSTEM (LOW TIRE PRESSURE WARNING CONTROL UNIT)</b> .....	DTC Logic .....	
CONSULT Function .....	Diagnosis Procedure .....	
<b>ECU DIAGNOSIS INFORMATION</b> .....	<b>C1716, C1717, C1718, C1719 TIRE PRESSURE SENSOR</b> .....	
<b>LOW TIRE PRESSURE WARNING CONTROL UNIT</b> .....	DTC Logic .....	
Reference Value .....	Diagnosis Procedure .....	
DTC Inspection Priority Chart .....		
DTC Index .....		

<b>C1728 RECEIVER ID</b> .....	<b>32</b>	Description .....	51
DTC Logic .....	32	Diagnosis Procedure .....	51
Diagnosis Procedure .....	32		
<b>C1729 VEHICLE SPEED SIGNAL</b> .....	<b>34</b>	<b>ID REGISTRATION CANNOT BE COMPLET-</b>	<b>ED</b> .....
DTC Logic .....	34	Description .....	52
Diagnosis Procedure .....	34	Diagnosis Procedure .....	52
<b>C1750, C1751, C1752, C1753 RECEIVER</b> .....	<b>35</b>	<b>HAZARD WARNING LAMP REMAINS ON</b> .....	<b>53</b>
DTC Logic .....	35	Description .....	53
Diagnosis Procedure .....	35	Diagnosis Procedure .....	53
<b>C1754 LOW TIRE PRESSURE WARNING CONTROL UNIT</b> .....	<b>38</b>	<b>NOISE, VIBRATION AND HARSHNESS (NVH) TROUBLESHOOTING</b> .....	<b>54</b>
DTC Logic .....	38	NVH Troubleshooting Chart .....	54
Diagnosis Procedure .....	38		
<b>C1755, C1756, C1757, C1758 POOR RECEIVING CONDITIONS</b> .....	<b>40</b>	<b>PERIODIC MAINTENANCE</b> .....	<b>55</b>
DTC Logic .....	40	<b>ROAD WHEEL</b> .....	<b>55</b>
Diagnosis Procedure .....	40	Adjustment .....	55
<b>U1000 CAN COMM CIRCUIT</b> .....	<b>42</b>	<b>REMOVAL AND INSTALLATION</b> .....	<b>57</b>
Description .....	42	<b>ROAD WHEEL TIRE ASSEMBLY</b> .....	<b>57</b>
DTC Logic .....	42	Exploded View .....	57
Diagnosis Procedure .....	42	Removal and Installation .....	57
<b>U1010 CONTROL UNIT (CAN)</b> .....	<b>43</b>	Inspection .....	57
Description .....	43	<b>LOW TIRE PRESSURE WARNING CONTROL UNIT</b> .....	<b>59</b>
DTC Logic .....	43	Exploded View .....	59
Diagnosis Procedure .....	43	Removal and Installation .....	59
<b>POWER SUPPLY AND GROUND CIRCUIT</b> ....	<b>44</b>	<b>TIRE PRESSURE SENSOR</b> .....	<b>60</b>
Diagnosis Procedure .....	44	Exploded View .....	60
<b>LOW TIRE PRESSURE WARNING LAMP</b> .....	<b>45</b>	Removal and Installation .....	60
Component Function Check .....	45	<b>TIRE PRESSURE RECEIVER</b> .....	<b>62</b>
Diagnosis Procedure .....	45	Exploded View .....	62
<b>SYMPTOM DIAGNOSIS</b> .....	<b>46</b>	<b>FRONT TIRE PRESSURE RECEIVER</b> .....	<b>62</b>
<b>TPMS SYMPTOMS</b> .....	<b>46</b>	FRONT TIRE PRESSURE RECEIVER : Removal and Installation .....	62
Symptom Table .....	46	<b>REAR TIRE PRESSURE RECEIVER</b> .....	<b>62</b>
<b>LOW TIRE PRESSURE WARNING LAMP DOES NOT TURN ON</b> .....	<b>49</b>	REAR TIRE PRESSURE RECEIVER : Removal and Installation .....	62
Description .....	49	<b>SERVICE DATA AND SPECIFICATIONS (SDS)</b> .....	<b>63</b>
Diagnosis Procedure .....	49	<b>SERVICE DATA AND SPECIFICATIONS (SDS)</b> .....	<b>63</b>
<b>LOW TIRE PRESSURE WARNING LAMP DOES NOT TURN OFF</b> .....	<b>50</b>	Road Wheel .....	63
Description .....	50	Tire Air Pressure .....	63
Diagnosis Procedure .....	50		
<b>LOW TIRE PRESSURE WARNING LAMP BLINKS</b> .....	<b>51</b>		

# PRECAUTIONS

< PRECAUTION >

## PRECAUTION

### PRECAUTIONS

#### Precaution for Supplemental Restraint System (SRS) "AIR BAG" and "SEAT BELT PRE-TENSIONER"

INFOID:000000008134836

The Supplemental Restraint System such as "AIR BAG" and "SEAT BELT PRE-TENSIONER", used along with a front seat belt, helps to reduce the risk or severity of injury to the driver and front passenger for certain types of collision. This system includes seat belt switch inputs and dual stage front air bag modules. The SRS system uses the seat belt switches to determine the front air bag deployment, and may only deploy one front air bag, depending on the severity of a collision and whether the front occupants are belted or unbelted. Information necessary to service the system safely is included in the "SRS AIR BAG" and "SEAT BELT" of this Service Manual.

#### **WARNING:**

Always observe the following items for preventing accidental activation.

- To avoid rendering the SRS inoperative, which could increase the risk of personal injury or death in the event of a collision that would result in air bag inflation, all maintenance must be performed by an authorized NISSAN/INFINITI dealer.
- Improper maintenance, including incorrect removal and installation of the SRS, can lead to personal injury caused by unintentional activation of the system. For removal of Spiral Cable and Air Bag Module, see "SRS AIR BAG".
- Never use electrical test equipment on any circuit related to the SRS unless instructed to in this Service Manual. SRS wiring harnesses can be identified by yellow and/or orange harnesses or harness connectors.

#### PRECAUTIONS WHEN USING POWER TOOLS (AIR OR ELECTRIC) AND HAMMERS

#### **WARNING:**

Always observe the following items for preventing accidental activation.

- When working near the Air Bag Diagnosis Sensor Unit or other Air Bag System sensors with the ignition ON or engine running, never use air or electric power tools or strike near the sensor(s) with a hammer. Heavy vibration could activate the sensor(s) and deploy the air bag(s), possibly causing serious injury.
- When using air or electric power tools or hammers, always switch the ignition OFF, disconnect the battery, and wait at least 3 minutes before performing any service.

#### Precautions Necessary for Steering Wheel Rotation After Battery Disconnection

INFOID:000000008358584

#### **CAUTION:**

Comply with the following cautions to prevent any error and malfunction.

- Before removing and installing any control units, first turn the ignition switch to the LOCK position, then disconnect both battery cables.
- After finishing work, confirm that all control unit connectors are connected properly, then re-connect both battery cables.
- Always use CONSULT to perform self-diagnosis as a part of each function inspection after finishing work. If a DTC is detected, perform trouble diagnosis according to self-diagnosis results.

For vehicle with steering lock unit, if the battery is disconnected or discharged, the steering wheel will lock and cannot be turned.

If turning the steering wheel is required with the battery disconnected or discharged, follow the operation procedure below before starting the repair operation.

#### OPERATION PROCEDURE

1. Connect both battery cables.

#### **NOTE:**

Supply power using jumper cables if battery is discharged.

2. Turn the ignition switch to ACC position.  
(At this time, the steering lock will be released.)
3. Disconnect both battery cables. The steering lock will remain released with both battery cables disconnected and the steering wheel can be turned.

# PRECAUTIONS

## < PRECAUTION >

---

4. Perform the necessary repair operation.
5. When the repair work is completed, re-connect both battery cables. With the brake pedal released, turn the ignition switch from ACC position to ON position, then to LOCK position. (The steering wheel will lock when the ignition switch is turned to LOCK position.)
6. Perform self-diagnosis check of all control units using CONSULT.

## Service Notice and Precautions for TPMS

INFOID:000000008134837

- Low tire pressure warning lamp blinks for 1min, then turns ON when occurring any malfunction except low tire pressure. Erase the self-diagnosis memories for low tire pressure warning control unit, or register the ID to turn low tire pressure warning lamp OFF. For ID registration, refer to [WT-23, "Work Procedure"](#).
- ID registration is required when replacing or rotating wheels, replacing tire pressure sensor or low tire pressure warning control unit. Refer to [WT-23, "Work Procedure"](#).
- Replace grommet seal, valve core and cap of tire pressure sensor in TPMS, when replacing each tire by reaching the wear limit. Refer to [WT-60, "Exploded View"](#).

## Service Notice and Precautions for Road Wheel

INFOID:000000008134838

- Genuine NISSAN aluminum wheel is designed for each type of vehicle. Use it on the specified vehicle only.
- Use Genuine NISSAN parts for the wheel nuts.
- Always use them after adjusting the wheel balance. For the balance weights, use Genuine NISSAN aluminum wheel weights.
- Use caution when handling the aluminum wheels, because they can be easily scratched. When removing dirt, do not use any abrasives, a wire brush, or other items that may scratch the coating. Use a neutral detergent if a detergent is needed.
- After driving on roads scattered with anti-icing salts, wash off the wheels completely.
- When installing road wheels onto the vehicle, always wipe off any dirt or foreign substances to prevent them from being trapped between the contact surfaces of wheel.
- Never apply oil to nut and bolt threads.

# PREPARATION

< PREPARATION >

## PREPARATION

### PREPARATION

#### Special Service Tools

INFOID:000000008134839

The actual shapes of Kent-Moore tools may differ from those of special service tools illustrated here.

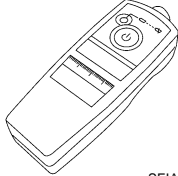
Tool number (Kent-Moore No.) Tool name	Description
— (J-45295) Tire pressure sensor activation tool   SEIA0462E	Tire pressure sensor wake-up procedure and ID registration

#### Commercial Service Tools

INFOID:000000008134840

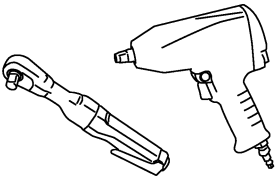
Tool name	Description
Power tool   PBIC0190E	Loosening wheel nuts

A  
B  
C  
D  
WT  
F  
G  
H  
I  
J  
K  
L  
M  
N  
O  
P

# COMPONENT PARTS

< SYSTEM DESCRIPTION >

## SYSTEM DESCRIPTION

### COMPONENT PARTS

#### Component Parts Location

INFOID:000000008134841

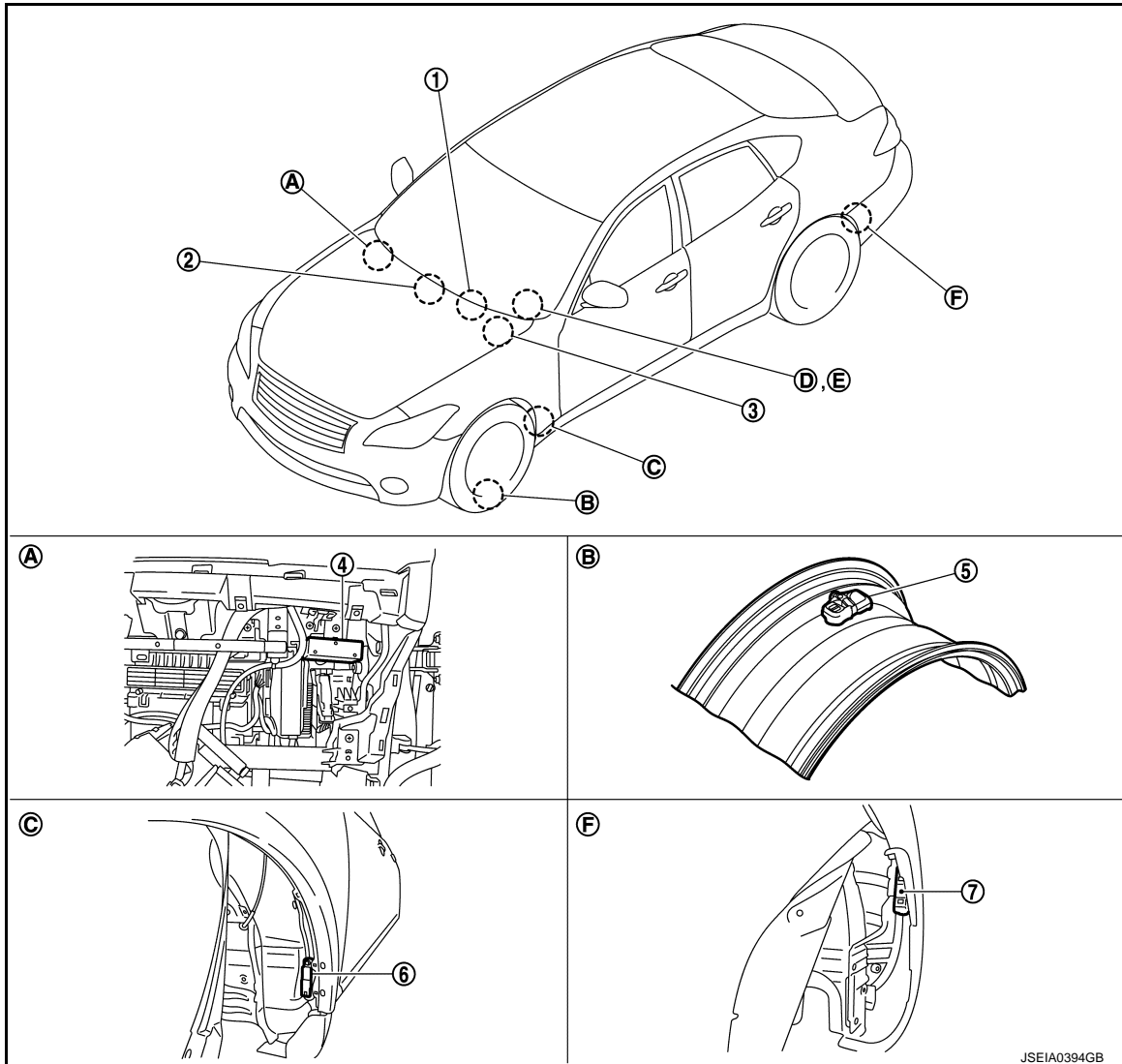

- |  |  |   |
|--|--|---|
| 1. BCM<br>Refer to <a href="#">BCS-4, "BODY CONTROL SYSTEM : Component Parts Location"</a> . | 2. AV control unit<br>Refer to <a href="#">AV-11, "Component Parts Location"</a> (without navigation) or <a href="#">AV-129, "Component Parts Location"</a> (with navigation). | 3. ABS actuator and electric unit (control unit)<br>Refer to <a href="#">BRC-10, "Component Parts Location"</a> . |
| 4. Low tire pressure warning control unit  | 5. Tire pressure sensor  | 6. Front tire pressure receiver   |
| 7. Rear tire pressure receiver   |  |   |
| A. Glove box assembly removed  | B. Wheel   | C. Fender protector (rear side)   |
| D. Low tire pressure warning lamp, information display (in combination meter)                | E. Buzzer (in combination meter)   | F. Inside rear wheel house protector  |

JSEIA0394GB

# COMPONENT PARTS

< SYSTEM DESCRIPTION >

## Component Description

INFOID:000000008134842

Component parts	Reference/Function
Tire pressure sensor	<a href="#">WT-7, "Tire Pressure Sensor"</a>
Tire pressure receiver	<a href="#">WT-8, "Tire Pressure Receiver"</a>
Low tire pressure warning control unit	<a href="#">WT-7, "Low Tire Pressure Warning Control Unit"</a>
Low tire pressure warning lamp	<a href="#">WT-9, "System Description"</a>
Combination meter (buzzer)	<a href="#">MWI-9, "METER SYSTEM : System Description"</a>
AV control unit	<a href="#">AV-12, "Component Description"</a> (Without navigation), <a href="#">AV-132, "Component Description"</a> (With navigation).
BCM	<a href="#">BCS-5, "BODY CONTROL SYSTEM : System Description"</a>
ABS actuator and electric unit (control unit)	<a href="#">BRC-11, "Component Description"</a>
Information display	<a href="#">WT-8, "Information Display"</a>

A

B

C

D

WT

## Low Tire Pressure Warning Control Unit

INFOID:000000008134843

- After the low tire pressure warning control unit (1) receives the tire pressure signal from the tire pressure receiver, it controls the operation of the low tire pressure warning lamp and buzzer.
- Performs self-diagnosis of the Tire Pressure Monitoring System (TPMS).

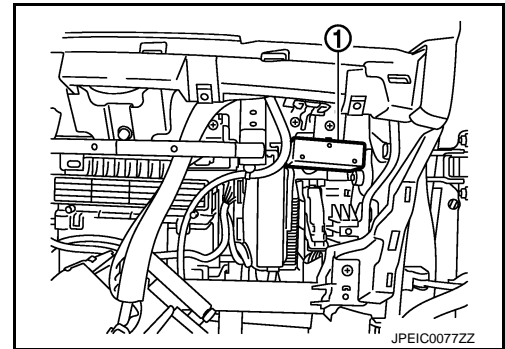

F

G

H

I

## Tire Pressure Sensor

INFOID:000000008134844

The tire pressure sensor (1) is installed at the position of the air valve on the road wheel (2). It measures the tire pressure and transmits the tire pressure information by radio waves.

↔ : Outside

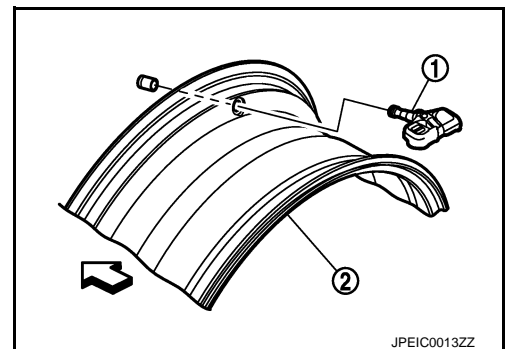

J

K

L

M

N

O

P

# COMPONENT PARTS

## < SYSTEM DESCRIPTION >

### Tire Pressure Receiver

INFOID:000000008134845

The front tire pressure receiver (1) and rear tire pressure receiver (2) receive the tire pressure signal by radio waves from the tire pressure sensor at each wheel, and transmit the tire pressure signal to the low tire pressure warning control unit.

A : Front side

B : Rear side

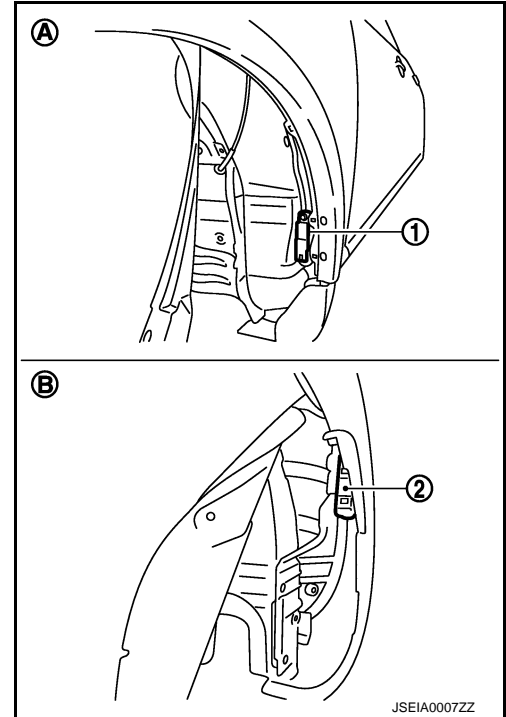

### Information Display

INFOID:000000008134846

The vehicle information display is shown when a low tire pressure warning lamp signal is transmitted from BCM to combination meter via CAN communication.

Condition		Vehicle information display
Ignition switch OFF		Not indicated
Ignition switch ON	Low tire pressure warning lamp remains ON after blinking for one minute. [Tire Pressure Monitoring System (TPMS) malfunction.]	Not indicated
Ignition switch ON	Low tire pressure warning lamp remains ON. (low tire pressure)	Indicated



# SYSTEM

< SYSTEM DESCRIPTION >

## SYSTEM

### System Description

INFOID:000000008134847

- During driving, the TPMS (Tire Pressure Monitoring System) receives the signal transmitted from tire pressure sensor installed in each wheel. The low tire pressure warning control unit has pressure judgment and trouble diagnosis functions. When the low tire pressure warning control unit detects low inflation pressure or another unusual symptom, the low tire pressure warning lamps in the combination meter comes on.
- If the tire pressure is less than the specified value, the low tire pressure warning lamp illuminates that the tire pressure is less than the specified value.
- Activates the TPMS (Tire Pressure Monitoring System) when the vehicle speed is 40 km/h (25 MPH) or more.
- The tire pressure information for each wheel is displayed on the vehicle information display.

### SYSTEM DIAGRAM

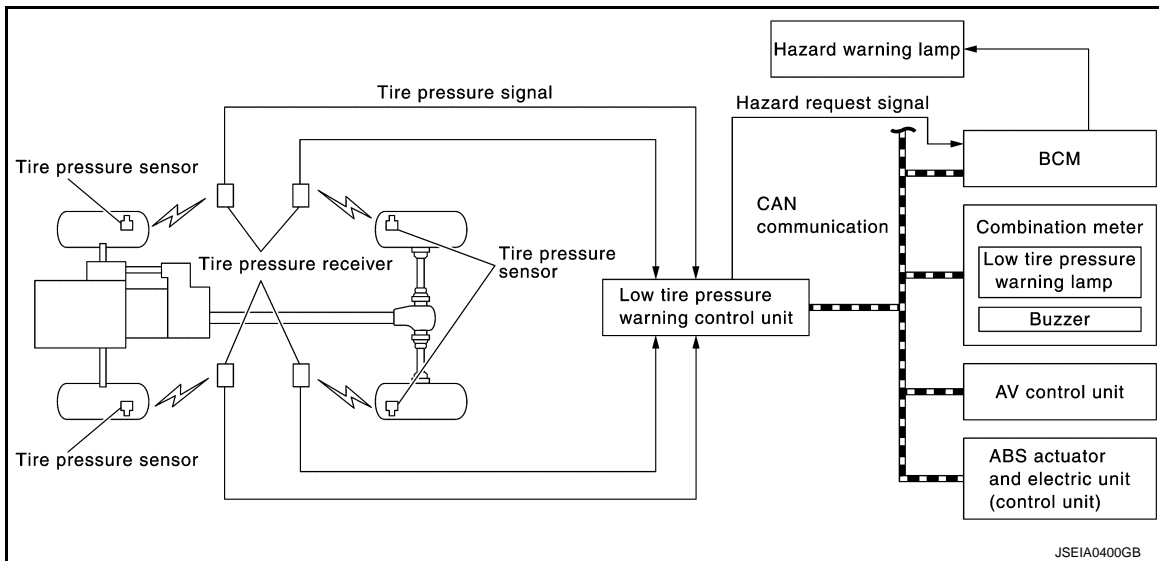

### INPUT/OUTPUT SIGNAL

The signal transmission/reception between units via a communication line is mainly as listed in the following table.

Component parts	Signal item
Low tire pressure warning control unit	Transmits the following signals via CAN communication to the BCM. <ul style="list-style-type: none"> <li>• Low tire pressure warning lamp signal</li> <li>• Buzzer request signal</li> </ul> Transmits the following signal via CAN communication to the AV control unit. <ul style="list-style-type: none"> <li>• Low tire pressure warning lamp signal</li> <li>• Tire pressure data signal</li> </ul>
BCM	Transmits the following signals via CAN communication to the combination meter, based on signals from low tire pressure warning control unit. <ul style="list-style-type: none"> <li>• Low tire pressure warning lamp signal</li> <li>• Buzzer request signal</li> </ul>
AV control unit	Receives the following signal via CAN communication from low tire pressure warning control unit. <ul style="list-style-type: none"> <li>• Low tire pressure warning lamp signal</li> <li>• Tire pressure data signal</li> </ul>
ABS actuator and electric unit (control unit)	Transmits the following signal via CAN communication to low tire pressure warning control unit. <ul style="list-style-type: none"> <li>• Vehicle speed signal</li> </ul>

### LOW TIRE PRESSURE WARNING LAMP CONTROL CONDITION

Uses CAN communication from the low tire pressure warning control unit to illuminate the low tire pressure warning lamp on the combination meter.

# SYSTEM

## < SYSTEM DESCRIPTION >

Condition	Low tire pressure warning lamp
Ignition switch OFF	OFF
Ignition switch ON (system normal)	Warning lamp turns on for 1second, then turns off.
Low tire pressure	ON
Tire pressure sensor ID not registered in BCM.	
Tire pressure monitoring system malfunction (Other diagnostic item)	Warning lamp blinks 1 min, then turns on.
Tire pressure sensor is in OFF state	Blink (Blinking pattern depends on the positions of non-operational tire pressure sensors.)
When performing tire pressure sensor wake-up operation	Refer to <a href="#">WT-22, "Work Procedure"</a> .

### HAZARD WARNING LAMP CONTROL CONDITION

The low tire pressure warning control unit transmits a hazard request signal to BCM. BCM blinks the hazard warning lamp, according to the signal.

The hazard warning lamp blinks under the following conditions.

Condition of Blinking The Hazard Warning Lamp

- When wake-up of registered wheel has been completed. Refer to [WT-22, "Work Procedure"](#).
- When ID registration is completed. Refer to [WT-23, "Work Procedure"](#).

### BUZZER CONTROL CONDITION

The low tire pressure warning control unit transmits a buzzer request signal to BCM. Based on the signal, BCM sends a command to the combination meter to sound the buzzer.

The buzzer sounds under the following conditions.

Condition of Sounding Buzzer

- When wake-up of registered wheel has been completed. Refer to [WT-22, "Work Procedure"](#).

# DIAGNOSIS SYSTEM (LOW TIRE PRESSURE WARNING CONTROL UNIT)

< SYSTEM DESCRIPTION >

## DIAGNOSIS SYSTEM (LOW TIRE PRESSURE WARNING CONTROL UNIT)

### CONSULT Function

INFOID:000000008134848

### APPLICATION ITEMS

CONSULT performs the following functions in combination of data reception, instruction, and transmission via communication lines from low tire pressure warning control unit.

Mode	FUNCTION DESCRIPTION
ECU identification information	Displays the part number of low tire pressure warning control unit.
SELF-DIAGNOSIS RESULTS	Self-diagnosis result can be quickly read.*
DATA MONITOR	Input and output data of low tire pressure warning control unit can be read.
ACTIVE TEST	Sends command to the low tire pressure warning control unit to change output signals and check operation of output system.
WORK SUPPORT	Components can be quickly and accurately adjusted.

\*: The following diagnosis information is erased by erasing.

- DTC

### ECU IDENTIFICATION

Part number of low tire pressure warning control unit is displayed.

### SELF DIAGNOSIS RESULTS

Refer to [WT-17, "DTC Index"](#).

### DATA MONITOR

Monitor item (Unit)	Remarks
VHCL SPEED SE [(km/h) or (MPH)]	Vehicle speed is displayed.
AIR PRESS FL [(kPa), (kg/cm <sup>2</sup> ) or (Psi)]	Air pressure of front LH tires is displayed.
AIR PRESS FR [(kPa), (kg/cm <sup>2</sup> ) or (Psi)]	Air pressure of front RH tires is displayed.
AIR PRESS RR [(kPa), (kg/cm <sup>2</sup> ) or (Psi)]	Air pressure of rear RH tires is displayed.
AIR PRESS RL [(kPa), (kg/cm <sup>2</sup> ) or (Psi)]	Air pressure of rear LH tires is displayed.
ID REGST FL1	ID registration status of front LH tire pressure sensor is displayed.
ID REGST FR1	ID registration status of front RH tire pressure sensor is displayed.
ID REGST RR1	ID registration status of rear RH tire pressure sensor is displayed.
ID REGST RL1	ID registration status of rear LH tire pressure sensor is displayed.
WARNING LAMP	Control status of low tire pressure warning lamp is displayed.
BUZZER	Control status of combination meter buzzer by low tire pressure warning control unit is displayed.

### ACTIVE TEST

#### NOTE:

After completing the work below, perform an active test.

1. Check ID registration state and perform self-diagnosis.
2. Erase the self-diagnosis result history.

# DIAGNOSIS SYSTEM (LOW TIRE PRESSURE WARNING CONTROL UNIT)

## < SYSTEM DESCRIPTION >

Test item	Condition	Description
BUZZER	<ul style="list-style-type: none"><li>• Vehicle stopped</li><li>• The system is normal</li></ul>	This test is able to check to check that the buzzer operates.
WARN LAMP		This test is able to check to check that the low tire pressure warning lamp turns on.

## WORK SUPPORT

Item	Usage
ID READ	Registered tire pressure sensor ID can be displayed.
ID REGIST	Tire pressure sensor ID can be registered. Refer to <a href="#">WT-23, "Work Procedure"</a> .

# LOW TIRE PRESSURE WARNING CONTROL UNIT

< ECU DIAGNOSIS INFORMATION >

## ECU DIAGNOSIS INFORMATION

### LOW TIRE PRESSURE WARNING CONTROL UNIT

Reference Value

INFOID:000000008134849

VALUES ON THE DIAGNOSIS TOOL

**CAUTION:**

The reference values in the table below come from the control unit calculation data. The normal values may in some cases be displayed even though the power circuit (harness) is open or shorted.

Monitor item	Condition	Value/Status
VHCL SPEED SE	Vehicle stopped	0.00 km/h (0.00 mph)
	Vehicle running <b>CAUTION:</b> Check air pressure of tire under standard condition.	Approx. equal to the indication on speed meter (Inside of ±10%)
AIR PRESS FL	Start engine and drive at 40 km/h (25 MPH) or more for 10 minutes.	Approximately equal to the indication on tire gauge value for front LH tire
AIR PRESS FR	Start engine and drive at 40 km/h (25 MPH) or more for 10 minutes.	Approximately equal to the indication on tire gauge value for front RH tire
AIR PRESS RR	Start engine and drive at 40 km/h (25 MPH) or more for 10 minutes.	Approximately equal to the indication on tire gauge value for rear RH tire
AIR PRESS RL	Start engine and drive at 40 km/h (25 MPH) or more for 10 minutes.	Approximately equal to the indication on tire gauge value for rear LH tire
ID REGST FL1	Front LH tire pressure sensor ID registered	Done
	Front LH tire pressure sensor ID unregistered	Yet
ID REGST FR1	Front RH tire pressure sensor ID registered	Done
	Front RH tire pressure sensor ID unregistered	Yet
ID REGST RR1	Rear RH tire pressure sensor ID registered	Done
	Rear RH tire pressure sensor ID unregistered	Yet
ID REGST RL1	Rear LH tire pressure sensor ID registered	Done
	Rear LH tire pressure sensor ID unregistered	Yet
WARNING LAMP	Low tire pressure warning lamp: ON	On
	Low tire pressure warning lamp: OFF	Off
BUZZER	When buzzer sound heard from combination meter by low tire pressure warning control unit control	On
	When buzzer sound not heard from combination meter by low tire pressure warning control unit control	Off

### TERMINAL LAYOUT

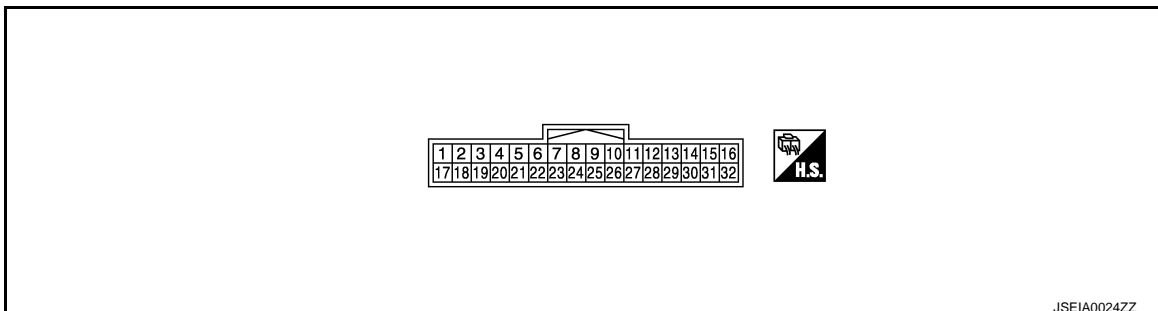

# LOW TIRE PRESSURE WARNING CONTROL UNIT

< ECU DIAGNOSIS INFORMATION >

## PHYSICAL VALUES

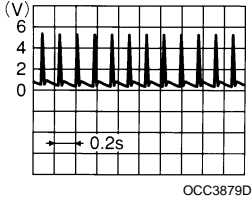
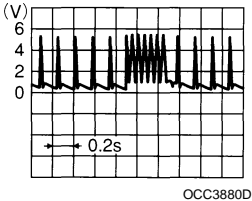
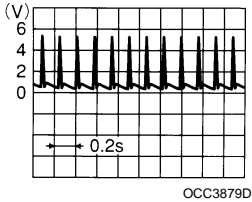
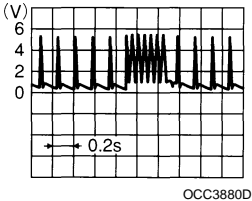

**CAUTION:**

**When using circuit tester to measure voltage for inspection, be sure not to extend forcibly any connector terminals.**

Terminal No. (Wire color)		Description		Condition	Value (Approx.)
		Signal name	Input/ Output		
1 (P)	—	CAN-L	Input/ Output	—	—
2 (L)	—	CAN-H	Input/ Output	—	—
3 (B)	Ground	Tire pressure receiver rear RH signal	Input	Ignition switch ON	Standby status  Approx. 4.5 V
					When signal is received  Approx. 4.5 V
4 (B)	Ground	Tire pressure receiver rear LH signal	Input	Ignition switch ON	Standby status  Approx. 4.5 V
					When signal is received  Approx. 4.5 V

# LOW TIRE PRESSURE WARNING CONTROL UNIT

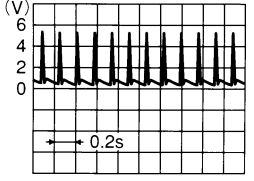
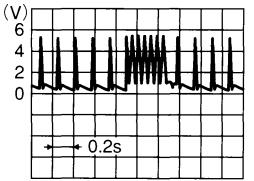
## < ECU DIAGNOSIS INFORMATION >

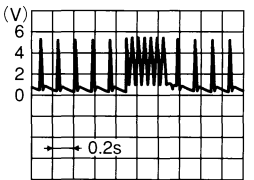
Terminal No. (Wire color)	Description		Condition	Value (Approx.)	
	Signal name	Input/ Output			
5 (B)	Ground	Tire pressure receiver front RH signal	Input	Ignition switch ON	 <p style="text-align: center;">Approx. 4.5 V</p>
				When signal is received	 <p style="text-align: center;">Approx. 4.5 V</p>
6 (G)	Ground	Tire pressure receiver front LH signal	Input	Ignition switch ON	 <p style="text-align: center;">Approx. 4.5 V</p>
				When signal is received	 <p style="text-align: center;">Approx. 4.5 V</p>
7 (R)	Ground	Tire pressure receiver rear RH power supply*	Output	Ignition switch ON Ignition switch OFF	Approx. 7 - 16 V 0 V
8 (W)	Ground	Tire pressure receiver rear LH power supply*	Output	Ignition switch ON Ignition switch OFF	Approx. 7 - 16 V 0 V
9 (W)	Ground	Tire pressure receiver front RH power supply*	Output	Ignition switch ON Ignition switch OFF	Approx. 7 - 16 V 0 V
10 (W)	Ground	Tire pressure receiver front LH power supply*	Output	Ignition switch ON Ignition switch OFF	Approx. 7 - 16 V 0 V
15 (Y)	Ground	Power supply	Input	Ignition switch ON Ignition switch OFF	Battery voltage 0 V
19 (G)	Ground	Tire pressure receiver rear RH signal (sensitivity)	Input	Ignition switch ON Ignition switch OFF	Approx. 0.7 V 0 V
20 (G)	Ground	Tire pressure receiver rear LH signal (sensitivity)	Input	Ignition switch ON Ignition switch OFF	Approx. 0.7 V 0 V

A  
B  
C  
D  
WT  
F  
G  
H  
I  
J  
K  
L  
M  
N  
O  
P

# LOW TIRE PRESSURE WARNING CONTROL UNIT

## < ECU DIAGNOSIS INFORMATION >

Terminal No. (Wire color)		Description		Condition	Value (Approx.)
		Signal name	Input/ Output		
21 (G)	Ground	Tire pressure receiver front RH signal (sensitivity)	Input	Ignition switch ON	Approx. 0.7 V
				Ignition switch OFF	0 V
22 (R)	Ground	Tire pressure receiver front LH signal (sensitivity)	Input	Ignition switch ON	Approx. 0.7 V
				Ignition switch OFF	0 V
23 (W)	Ground	Tire pressure receiver rear RH ground	Input	Always	0 V
24 (R)	Ground	Tire pressure receiver rear LH ground	Input	Always	0 V
25 (R)	Ground	Tire pressure receiver front RH ground	Input	Always	0 V
26 (B)	Ground	Tire pressure receiver front LH ground	Input	Always	0 V
30 (G)	Ground	Hazard warning lamp	Output	Hazard warning lamp switch ON	0 V
				Hazard warning lamp switch OFF	Battery voltage
32 (B)	Ground	Ground	—	Always	0 V

\*: Power is supplied to the tire pressure receiver from the low tire pressure warning control unit.

## DTC Inspection Priority Chart

INFOID:000000008134850

If some DTCs are displayed at the same time, perform inspections one by one based on the following priority chart.

Priority	Detected items (DTC)
1	<ul style="list-style-type: none"> <li>• U1000 CAN COMM CIRCUIT</li> <li>• U1010 CONTROL UNIT (CAN)</li> </ul>
2	<ul style="list-style-type: none"> <li>• C1704 LOW PRESSURE FL</li> <li>• C1705 LOW PRESSURE FR</li> <li>• C1706 LOW PRESSURE RR</li> <li>• C1707 LOW PRESSURE RL</li> </ul>
3	<ul style="list-style-type: none"> <li>• C1755 PR RECEIV COND FL</li> <li>• C1756 PR RECEIV COND FR</li> <li>• C1757 PR RECEIV COND RR</li> <li>• C1758 PR RECEIV COND RL</li> </ul>
4	<ul style="list-style-type: none"> <li>• C1708 [NO DATA] FL</li> <li>• C1709 [NO DATA] FR</li> <li>• C1710 [NO DATA] RR</li> <li>• C1711 [NO DATA] RL</li> </ul>
5	<ul style="list-style-type: none"> <li>• C1716 [PRESSDATA ERR] FL</li> <li>• C1717 [PRESSDATA ERR] FR</li> <li>• C1718 [PRESSDATA ERR] RR</li> <li>• C1719 [PRESSDATA ERR] RL</li> </ul>
7	<ul style="list-style-type: none"> <li>• C1728 RECEIVER ID NO REG</li> </ul>
8	<ul style="list-style-type: none"> <li>• C1729 VHCL SPEED SIG ERR</li> </ul>
9	<ul style="list-style-type: none"> <li>• C1750 [RECEIVER ERR] FL</li> <li>• C1751 [RECEIVER ERR] FR</li> <li>• C1752 [RECEIVER ERR] RR</li> <li>• C1753 [RECEIVER ERR] RL</li> </ul>
10	<ul style="list-style-type: none"> <li>• C1754 CONT UNIT (EEPROM)</li> </ul>



# LOW TIRE PRESSURE WARNING CONTROL UNIT

< ECU DIAGNOSIS INFORMATION >

## DTC Index

INFOID:000000008134851

DTC	Items (CONSULT screen terms)	Reference
C1704	LOW PRESSURE FL	<a href="#">WT-24, "DTC Logic"</a>
C1705	LOW PRESSURE FR	
C1706	LOW PRESSURE RR	
C1707	LOW PRESSURE RL	
C1708	[NO DATA] FL	<a href="#">WT-26, "DTC Logic"</a>
C1709	[NO DATA] FR	
C1710	[NO DATA] RR	
C1711	[NO DATA] RL	
C1716	[PRESSDATA ERR] FL	<a href="#">WT-30, "DTC Logic"</a>
C1717	[PRESSDATA ERR] FR	
C1718	[PRESSDATA ERR] RR	
C1719	[PRESSDATA ERR] RL	
C1728	RECEIVER ID NO REG	<a href="#">WT-32, "DTC Logic"</a>
C1729	VHCL SPEED SIG ERR	<a href="#">WT-34, "DTC Logic"</a>
C1750	[RECEIVER ERR] FL	<a href="#">WT-35, "DTC Logic"</a>
C1751	[RECEIVER ERR] FR	
C1752	[RECEIVER ERR] RR	
C1753	[RECEIVER ERR] RL	
C1754	CONT UNIT (EEPROM)	<a href="#">WT-38, "DTC Logic"</a>
C1755	PR RECEIV COND FL	<a href="#">WT-40, "DTC Logic"</a>
C1756	PR RECEIV COND FR	
C1757	PR RECEIV COND RR	
C1758	PR RECEIV COND RL	
U1000	CAN COMM CIRCUIT	<a href="#">WT-42, "DTC Logic"</a>
U1010	CONTROL UNIT (CAN)	<a href="#">WT-43, "DTC Logic"</a>

**NOTE:**

If some DTCs are displayed at the same time, refer to [WT-16, "DTC Inspection Priority Chart"](#).

A  
B  
C  
D  
WT  
F  
G  
H  
I  
J  
K  
L  
M  
N  
O  
P

# TIRE PRESSURE MONITORING SYSTEM

< WIRING DIAGRAM >

## WIRING DIAGRAM

### TIRE PRESSURE MONITORING SYSTEM

#### Wiring Diagram

INFOID:000000008134852

For connector terminal arrangements, harness layouts, and alphabets in a  (option abbreviation; if not described in wiring diagram), refer to [GI-12. "Connector Information"](#).

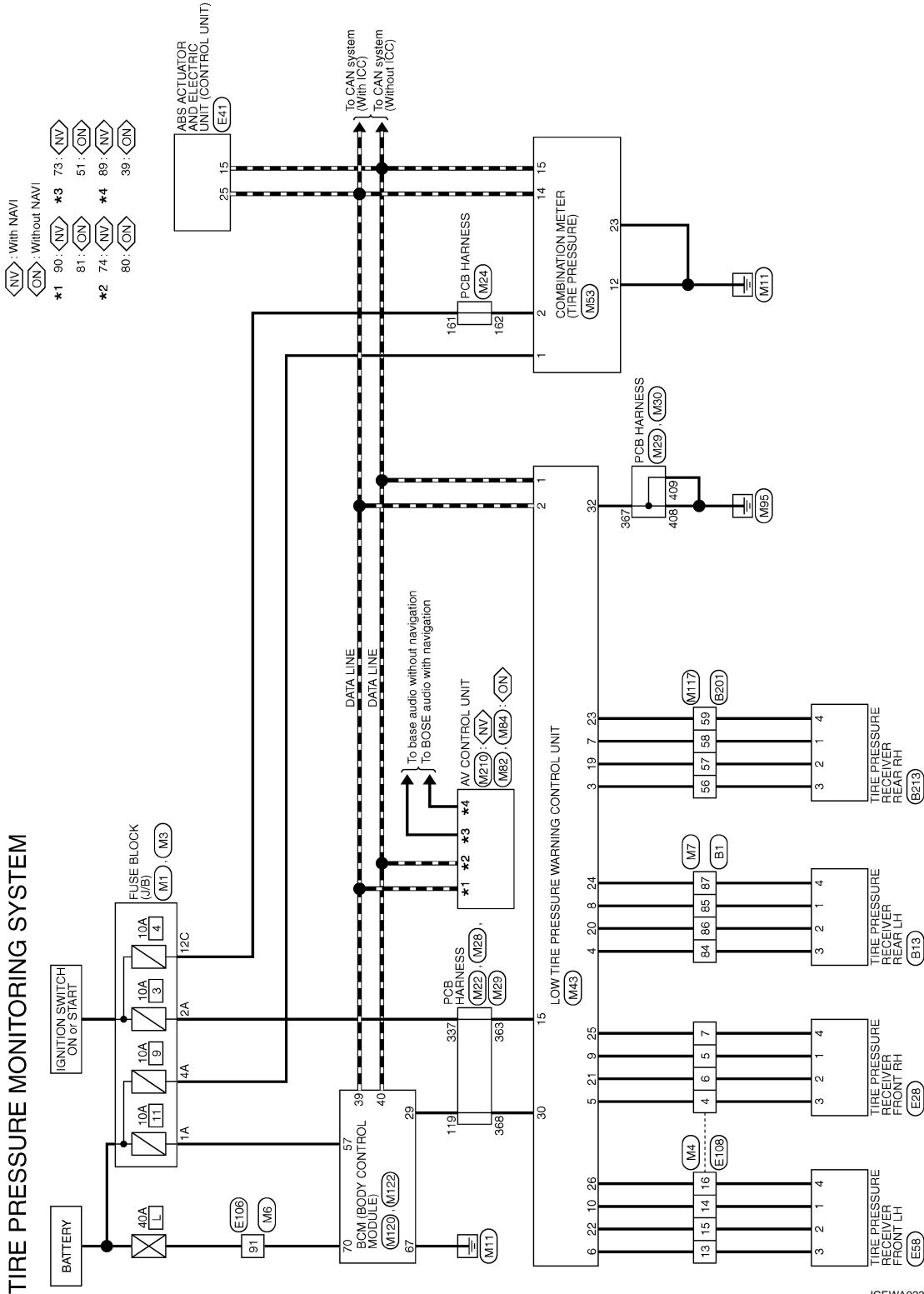

2010/12/14

JCEWA0233GB

# DIAGNOSIS AND REPAIR WORK FLOW

< BASIC INSPECTION >

## BASIC INSPECTION

### DIAGNOSIS AND REPAIR WORK FLOW

Work Flow

INFOID:000000008134853

DETAILED FLOW

#### 1. COLLECT THE INFORMATION FROM THE CUSTOMER

It is also important to clarify customer concerns before starting the inspection. Reproduce the symptom, and understand it fully. Interview the customer about the concerns carefully. In some cases, it is necessary to check the symptoms by driving the vehicle with the customer.

**CAUTION:**

**Customers are not professionals. Never assume “maybe the customer means...” or “maybe the customer mentioned this symptom.”**

>> GO TO 2.

#### 2. BASIC INSPECTION

1. Turn the ignition switch ON.

**CAUTION:**

**Never start the engine.**

2. Check the tire pressure for all wheels and adjust to the specified value. Refer to [WT-63. "Tire Air Pressure"](#).

Is the inspection result normal?

YES >> GO TO 3.

NO >> Inspect or repair the tires or wheels.

#### 3. CHECK LOW TIRE PRESSURE WARNING LAMP STATUS

Check low tire pressure warning lamp display.

Does not low tire pressure warning lamp turn OFF?

YES >> GO TO 4.

NO >> GO TO 8.

#### 4. CHECK DTC WITH LOW TIRE PRESSURE WARNING CONTROL UNIT

**With CONSULT**

Perform the self-diagnosis.

Is any DTC detected?

YES >> Record or print DTC and freeze frame data (FFD). GO TO 5.

NO >> GO TO 8.

#### 5. ERASE DTC MEMORY

**With CONSULT**

1. Record DTC.

2. Erase DTC once.

**NOTE:**

After erasing DTC record, currently occurred DTC can be detected by reading out DTC again.

>> GO TO 6.

#### 6. PERFORM DTC CONFIRMATION PROCEDURE

**With CONSULT**

Perform “DTC CONFIRMATION PROCEDURE” (self-diagnosis) with recorded DTC.

If two or more DTCs are detected, refer to [WT-16. "DTC Inspection Priority Chart"](#) and determine trouble diagnosis order.

Is any malfunction detected by self-diagnosis?

YES >> GO TO 7.

A

B

C

D

WT

F

G

H

I

J

K

L

M

N

O

P

# DIAGNOSIS AND REPAIR WORK FLOW

## < BASIC INSPECTION >

---

NO >> GO TO 8.

### 7. DETECT MALFUNCTIONING PART BY DIAGNOSIS PROCEDURE

---

Perform the diagnosis applicable to the displayed DTC. Refer to [WT-17, "DTC Index"](#).

>> GO TO 10.

### 8. CRUISE FOR SYMPTOM CHECK

---

1. Start the engine.
2. Drive for several minutes at a speed of 40 km/h (25 MPH) or more, then stop the vehicle.

>> GO TO 9.

### 9. PERFORM DIAGNOSIS BY SYMPTOM

---

Perform trouble diagnosis or repair applicable to the symptom. Refer to [WT-46, "Symptom Table"](#).

>> GO TO 11.

### 10. FINAL CHECK (WHEN DTC WAS DETECTED)

---

#### With CONSULT

Perform "DTC CONFIRMATION PROCEDURE" (self-diagnosis) with applicable DTC.

Is any malfunction detected by self-diagnosis?

YES >> GO TO 7.

NO >> INSPECTION END

### 11. FINAL CHECK (WHEN SYMPTOM OCCURRED)

---

Make sure that the symptom is not detected.

Does symptom remain?

YES >> GO TO 9.

NO >> INSPECTION END

# ADDITIONAL SERVICE WHEN REPLACING LOW TIRE PRESSURE WARNING CONTROL UNIT

< BASIC INSPECTION >

## ADDITIONAL SERVICE WHEN REPLACING LOW TIRE PRESSURE WARNING CONTROL UNIT

### Description

INFOID:000000008134854

When replacing low tire pressure warning control unit, tire pressure sensor ID registration is required.

### Work Procedure

INFOID:000000008134855

## ADJUST THE NEUTRAL POSITION OF STEERING ANGLE SENSOR

### 1. PERFORM TIRE PRESSURE SENSOR ID REGISTRATION

Perform tire pressure sensor ID registration.

>> Refer to [WT-23, "Work Procedure"](#).

A  
B  
C  
D  
E  
F  
G  
H  
I  
J  
K  
L  
M  
N  
O  
P

WT

# TIRE PRESSURE SENSOR WAKE UP OPERATION

< BASIC INSPECTION >

## TIRE PRESSURE SENSOR WAKE UP OPERATION

### Description

INFOID:000000008134856

When replacing tire pressure sensor, always tire pressure sensor wake-up is required.

### Work Procedure

INFOID:000000008134857

### 1. TIRE PRESSURE SENSOR WAKE-UP PROCEDURE

1. Turn the ignition switch ON.

**CAUTION:**

**Never start the engine.**

**NOTE:**

The position of an inactive tire pressure sensor can be identified by checking the blinking timing of the low tire pressure warning lamp.

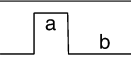
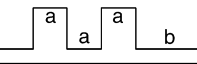
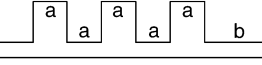
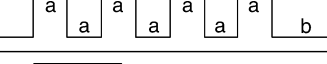
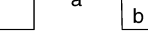
Low tire pressure warning lamp blinking timing		Activation tire position
ON OFF		Front LH a : 0.3 sec. b : 1.0 sec.
ON OFF		Front RH a : 0.3 sec. b : 1.0 sec.
ON OFF		Rear RH a : 0.3 sec. b : 1.0 sec.
ON OFF		Rear LH a : 0.3 sec. b : 1.0 sec.
ON OFF		All tires a : 2 sec. b : 0.2 sec.

JPEIC0089GB

2. Contact the tire pressure sensor activation tool (J-45295) (1) to the side of the tire at the location to the tire pressure sensor.
3. Press and hold the tire pressure sensor activation tool button while pushing the tool to the tire surface. (approximately for 5 seconds)

**CAUTION:**

**Perform the wake-up procedure starting from the vehicle front left wheel, then repeat the procedure in the order of the front right wheel, rear right wheel, and rear left wheel.**

4. Check that the turn signal lamps blink twice when the tire pressure sensor wake-up procedure for all wheels is completed.
5. Check that the low tire pressure warning lamp turns OFF, after the tire pressure sensor wake-up procedure is completed for all wheels and turns OFF.

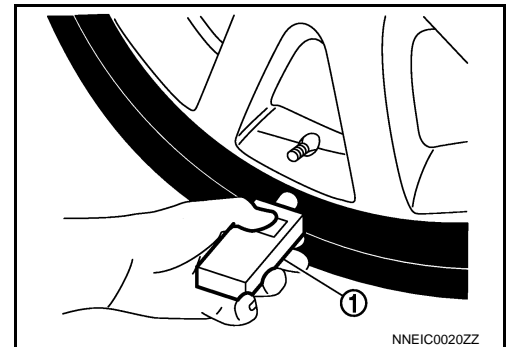

NNEIC0020ZZ

Is the tire pressure sensor wake-up procedure completed?

- YES >> Perform the tire pressure sensor ID registration procedure. Refer to [WT-23, "Work Procedure"](#).  
 NO >> Perform trouble diagnosis for the tire pressure sensor. Refer to [WT-26, "Diagnosis Procedure"](#).

# ID REGISTRATION

< BASIC INSPECTION >

## ID REGISTRATION

### Description

INFOID:000000008134858

When replacing or rotating wheels, replacing tire pressure sensor or low tire pressure warning control unit, always tire pressure sensor ID registration is required.

### Work Procedure

INFOID:000000008134859

#### 1. TIRE PRESSURE SENSOR ID REGISTRATION PROCEDURE

##### CAUTION:

To perform ID registration, observe the following points:

- Never register ID in a place where radio waves are interfered (e.g. radio tower).
- Never register ID in a place close to vehicles including TPMS.

Ⓜ With CONSULT.

1. Turn the ignition switch ON.
2. Display the "WORK SUPPORT" screen and select "ID REGIST".
3. Select the start button on the "ID REGIST" screen.
4. Contact the tire pressure sensor activation tool (J-45295) (1) to the side of the tire at the location to the tire pressure sensor.
5. Press and hold the tire pressure sensor tire pressure sensor activation tool button while pushing the tool to the tire surface. (approximately for 5 seconds)

##### CAUTION:

Perform the ID registration procedure starting from the vehicle front left wheel, then repeat the procedure in the order of the front right wheel, rear right wheel, and rear left wheel.

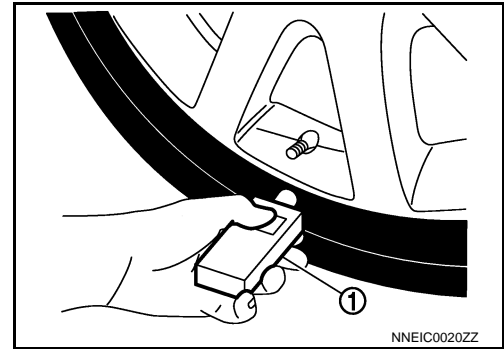

6. When ID registration is completed, check the following pattern at each wheel.

Sequence	ID registration position	Turn signal lamp	CONSULT
1	Front left wheel	2 blinks	"Red" ↓ "Green"
2	Front right wheel		
3	Rear right wheel		
4	Rear left wheel		

7. After the ID registration procedure for all wheels is completed, press "End" to end ID registration, and check that ID registration for all wheels is completed.

Is the check result normal?

- YES >> ID registration END.  
NO >> Refer to [WT-52. "Diagnosis Procedure"](#).

# C1704, C1705, C1706, C1707 LOW TIRE PRESSURE

< DTC/CIRCUIT DIAGNOSIS >

## DTC/CIRCUIT DIAGNOSIS

### C1704, C1705, C1706, C1707 LOW TIRE PRESSURE

#### DTC Logic

INFOID:000000008134860

#### DTC DETECTION LOGIC

DTC	Display Item	Malfunction detected condition	Possible causes
C1704	LOW PRESSURE FL	Front LH wheel pressure drops to 182 kPa (1.86 kg/cm <sup>2</sup> , 26.4 psi) or less	Low tire pressure
C1705	LOW PRESSURE FR	Front RH wheel pressure drops to 182 kPa (1.86 kg/cm <sup>2</sup> , 26.4 psi) or less	
C1706	LOW PRESSURE RR	Rear RH wheel pressure drops to 182 kPa (1.86 kg/cm <sup>2</sup> , 26.4 psi) or less	
C1707	LOW PRESSURE RL	Rear LH wheel pressure drops to 182 kPa (1.86 kg/cm <sup>2</sup> , 26.4 psi) or less	

#### DTC CONFIRMATION PROCEDURE

##### 1. PERFORM DTC CONFIRMATION

###### With CONSULT

1. Turn the ignition switch ON.

###### **CAUTION:**

**Never start the engine.**

2. Check the tire pressure for all wheels and adjust to the specified value. Refer to [WT-63, "Tire Air Pressure"](#).
3. Perform self-diagnosis for "AIR PRESSURE MONITOR".

Is DTC "C1704", "C1705", "C1706", or "C1707" detected?

YES >> Proceed to [WT-24, "Diagnosis Procedure"](#).

NO >> INSPECTION END

#### Diagnosis Procedure

INFOID:000000008134861

##### 1. CHECK TIRE PRESSURE

Check the air pressure of all wheels. Refer to [WT-63, "Tire Air Pressure"](#).

Is the inspection result normal?

YES >> Replace the DTC-detected malfunctioning tire pressure sensor. Refer to [WT-60, "Removal and Installation"](#).

NO >> After adjusting the air pressure, GO TO 2.

##### 2. CHECK TIRE PRESSURE SIGNAL

###### With CONSULT

1. Drive for 3 minutes at a speed of 40 km/h (25 MPH) or more, then drive normally for 10 minutes.
2. Stop the vehicle.
3. Select "DATA MONITOR" for "AIR PRESSURE MONITOR" with CONSULT.
4. Within 5 minutes after vehicle stopped, check that the tire pressures match the standard value.

Monitor item	Displayed value
AIR PRESS FL	Approximately equal to the indication on tire gauge value for front LH tire
AIR PRESS FR	Approximately equal to the indication on tire gauge value for front RH tire
AIR PRESS RR	Approximately equal to the indication on tire gauge value for rear RH tire
AIR PRESS RL	Approximately equal to the indication on tire gauge value for rear LH tire

Is the inspection result normal?

YES >> INSPECTION END



# C1704, C1705, C1706, C1707 LOW TIRE PRESSURE

< DTC/CIRCUIT DIAGNOSIS >

---

NO >> Repair or replace error-detected parts.

A

B

C

D

**WT**

F

G

H

I

J

K

L

M

N

O

P

# C1708, C1709, C1710, C1711 TIRE PRESSURE SENSOR

< DTC/CIRCUIT DIAGNOSIS >

## C1708, C1709, C1710, C1711 TIRE PRESSURE SENSOR

### DTC Logic

INFOID:000000008134862

#### DTC DETECTION LOGIC

DTC	Display Item	Malfunction detected condition	Possible causes
C1708	[NO DATA] FL	Tire pressure data signal from the front LH wheel tire pressure sensor cannot be detected.	<ul style="list-style-type: none"> <li>• Harness or connector connection malfunction (Tire pressure receiver, low tire pressure warning control unit)</li> <li>• Tire Pressure Sensor ID registration incomplete</li> <li>• Tire Pressure Sensor malfunction</li> <li>• Tire pressure sensor battery voltage</li> </ul>
C1709	[NO DATA] FR	Tire pressure data signal from the front RH wheel tire pressure sensor cannot be detected.	
C1710	[NO DATA] RR	Tire pressure data signal from the rear RH wheel tire pressure sensor cannot be detected.	
C1711	[NO DATA] RL	Tire pressure data signal from the rear LH wheel tire pressure sensor cannot be detected.	

#### DTC CONFIRMATION PROCEDURE

##### 1. PERFORM DTC CONFIRMATION

###### ④ With CONSULT

1. Drive for 3 minutes at a speed of 40 km/h (25 MPH) or more, then drive normally for 10 minutes.
2. Stop the vehicle.
3. Perform self-diagnosis for "AIR PRESSURE MONITOR".

Is DTC "C1708", "C1709", "C1710" or "C1711" detected?

YES >> Proceed to [WT-26, "Diagnosis Procedure"](#).

NO >> INSPECTION END

#### Diagnosis Procedure

INFOID:000000008134863

##### 1. CHECK TIRE PRESSURE SIGNAL

###### ④ With CONSULT

1. Drive for 3 minutes at a speed of 40 km/h (25 MPH) or more, then drive normally for 10 minutes.
2. Stop the vehicle.
3. Select "DATA MONITOR" for "AIR PRESSURE MONITOR" with CONSULT.
4. Within 5 minutes after vehicle stopped, read the values that are displayed for "AIR PRESS FL", "AIR PRESS FR", "AIR PRESS RR", and "AIR PRESS RL".

Are all tire pressures displayed 0 kPa (psi)?

YES >> GO TO 2.

NO >> GO TO 5.

##### 2. CHECK RECEIVER CIRCUIT

1. Turn the ignition switch OFF.
2. Disconnect low tire pressure warning control unit harness connector and tire pressure receiver harness connector.
3. Check the continuity between low tire pressure warning control unit harness connector and tire pressure receiver harness connector.

###### CHECK RECEIVER POWER CIRCUIT

Low tire pressure warning control unit		Tire pressure receiver		Continuity
Connector	Terminal	Connector	Terminal	
M43	10	E58 (Front LH)	1	Existed
	9	E28 (Front RH)		
	8	B13 (Rear LH)		
	7	B213 (Rear RH)		

# C1708, C1709, C1710, C1711 TIRE PRESSURE SENSOR

## < DTC/CIRCUIT DIAGNOSIS >

### CHECK RECEIVER SIGNAL CIRCUIT

Low tire pressure warning control unit		Tire pressure receiver		Continuity
Connector	Terminal	Connector	Terminal	
M43	6	E58 (Front LH)	3	Existed
	5	E28 (Front RH)		
	4	B13 (Rear LH)		
	3	B213 (Rear RH)		

### CHECK RECEIVER SIGNAL (SENSITIVITY) CIRCUIT

Low tire pressure warning control unit		Tire pressure receiver		Continuity
Connector	Terminal	Connector	Terminal	
M43	22	E58 (Front LH)	2	Existed
	21	E28 (Front RH)		
	20	B13 (Rear LH)		
	19	B213 (Rear RH)		

### CHECK RECEIVER GROUND CIRCUIT

Low tire pressure warning control unit		Tire pressure receiver		Continuity
Connector	Terminal	Connector	Terminal	
M43	26	E58 (Front LH)	4	Existed
	25	E28 (Front RH)		
	24	B13 (Rear LH)		
	23	B213 (Rear RH)		

4. Check the continuity between low tire pressure warning control unit harness connector and ground.

### CHECK RECEIVER POWER CIRCUIT

Low tire pressure warning control unit		—	Continuity
Connector	Terminal		
M43	10	Ground	Not existed
	9		
	8		
	7		

### CHECK RECEIVER SIGNAL CIRCUIT

Low tire pressure warning control unit		—	Continuity
Connector	Terminal		
M43	6	Ground	Not existed
	5		
	4		
	3		

### CHECK RECEIVER SIGNAL (SENSITIVITY) CIRCUIT

Low tire pressure warning control unit		—	Continuity
Connector	Terminal		
M43	22	Ground	Not existed
	21		
	20		
	19		

# C1708, C1709, C1710, C1711 TIRE PRESSURE SENSOR

## < DTC/CIRCUIT DIAGNOSIS >

### CHECK RECEIVER GROUND CIRCUIT

Low tire pressure warning control unit		—	Continuity
Connector	Terminal		
M43	26	Ground	Not existed
	25		
	24		
	23		

Is the inspection result normal?

YES >> GO TO 3.

NO >> Repair or replace the malfunctioning harness or connector.

### 3. CHECK TIRE PRESSURE RECEIVER POWER SUPPLY CIRCUIT

1. Connect low tire pressure warning control unit harness connector.
2. Turn the ignition switch ON.

#### CAUTION:

**Never start the engine.**

3. Check the voltage between tire pressure receiver harness connector and ground.

Tire pressure receiver		—	Voltage
Connector	Terminal		
E58 (Front LH)	1	Ground	Approx. 7 - 16 V
E28 (Front RH)			
B13 (Rear LH)			
B213 (Rear RH)			

Is the inspection result normal?

YES >> GO TO 4.

NO >> Replace the low tire pressure warning control unit. Refer to [WT-59, "Removal and Installation"](#).

### 4. TIRE PRESSURE RECEIVER SIGNAL

Check tire pressure receiver signal. Refer to [WT-35, "Diagnosis Procedure"](#).

Is the inspection result normal?

YES >> GO TO 5.

NO >> Repair or replace error-detected parts.

### 5. TIRE PRESSURE SENSOR ID REGISTRATION

Perform tire pressure sensor ID registration. Refer to [WT-23, "Work Procedure"](#).

Is tire pressure sensor ID registration completed?

YES >> GO TO 6.

NO >> Replace applicable tire pressure sensor. Refer to [WT-60, "Removal and Installation"](#).

### 6. CHECK TIRE PRESSURE SIGNAL

#### Ⓜ With CONSULT

1. Drive for 3 minutes at a speed of 40 km/h (25 MPH) or more, then drive normally for 10 minutes.
2. Stop the vehicle.
3. Select "DATA MONITOR" for "AIR PRESSURE MONITOR" with CONSULT.
4. Within 15 minutes after vehicle stopped, check that the tire pressures match the standard value.

Monitor item	Displayed value
AIR PRESS FL	Approximately equal to the indication on tire gauge value for front LH tire
AIR PRESS FR	Approximately equal to the indication on tire gauge value for front RH tire
AIR PRESS RR	Approximately equal to the indication on tire gauge value for rear RH tire
AIR PRESS RL	Approximately equal to the indication on tire gauge value for rear LH tire

Is the inspection result normal?

# C1708, C1709, C1710, C1711 TIRE PRESSURE SENSOR

## < DTC/CIRCUIT DIAGNOSIS >

---

YES >> INSPECTION END

NO >> Replace the low tire pressure warning control unit. Refer to [WT-59, "Removal and Installation"](#).

A

B

C

D

WT

F

G

H

I

J

K

L

M

N

O

P

# C1716, C1717, C1718, C1719 TIRE PRESSURE SENSOR

< DTC/CIRCUIT DIAGNOSIS >

## C1716, C1717, C1718, C1719 TIRE PRESSURE SENSOR

### DTC Logic

INFOID:000000008134864

### DTC DETECTION LOGIC

DTC	Display Item	Malfunction detected condition	Possible causes
C1716	[PRESSDATA ERR] FL	Malfunction in the tire pressure data from the front LH wheel tire pressure sensor. <b>NOTE:</b> In this case the low tire pressure warning control unit judges that the tire pressure is 438.60 kPa (4.47 kg/cm <sup>2</sup> , 63.60 psi).	<ul style="list-style-type: none"><li>• Tire pressure sensor ID registration incomplete</li><li>• Tire pressure sensor malfunction</li></ul>
C1717	[PRESSDATA ERR] FR	Malfunction in the tire pressure data from the front RH wheel tire pressure sensor. <b>NOTE:</b> In this case the low tire pressure warning control unit judges that the tire pressure is 438.60 kPa (4.47 kg/cm <sup>2</sup> , 63.60 psi).	
C1718	[PRESSDATA ERR] RR	Malfunction in the tire pressure data from the rear RH wheel tire pressure sensor. <b>NOTE:</b> In this case the low tire pressure warning control unit judges that the tire pressure is 438.60 kPa (4.47 kg/cm <sup>2</sup> , 63.60 psi).	
C1719	[PRESSDATA ERR] RL	Malfunction in the tire pressure data from the rear LH wheel tire pressure sensor. <b>NOTE:</b> In this case the low tire pressure warning control unit judges that the tire pressure is 438.60 kPa (4.47 kg/cm <sup>2</sup> , 63.60 psi).	

### DTC CONFIRMATION PROCEDURE

#### 1. PERFORM DTC CONFIRMATION

##### With CONSULT

1. Turn the ignition switch ON.

##### **CAUTION:**

**Never start the engine.**

2. Check the tire pressure for all wheels and adjust to the specified value. Refer to [WT-63, "Tire Air Pressure"](#).
3. Perform self-diagnosis for "AIR PRESSURE MONITOR".

Is DTC "C1716", "C1717", "C1718", or "C1719" detected?

- YES >> Proceed to [WT-30, "Diagnosis Procedure"](#).  
NO >> INSPECTION END

### Diagnosis Procedure

INFOID:000000008134865

#### 1. CHECK TIRE PRESSURE

Check the air pressure of all wheels. Refer to [WT-63, "Tire Air Pressure"](#).

Is the inspection result normal?

- YES >> Replace the DTC-detected malfunctioning tire pressure sensor. Refer to [WT-60, "Removal and Installation"](#).  
NO >> After adjusting the air pressure, GO TO 2.

#### 2. CHECK TIRE PRESSURE SIGNAL

##### With CONSULT

# C1716, C1717, C1718, C1719 TIRE PRESSURE SENSOR

## < DTC/CIRCUIT DIAGNOSIS >

1. Check the tire pressure for all wheels and adjust to the specified value. Refer to [WT-63. "Tire Air Pressure"](#). A
2. Perform tire pressure sensor ID registration for all wheels. Refer to [WT-23. "Work Procedure"](#).
3. Drive for 3 minutes at a speed of 40 km/h (25 MPH) or more, then drive normally for 10 minutes.
4. Stop the vehicle. B
5. Select "DATA MONITOR" for "AIR PRESSURE MONITOR" with CONSULT.
6. Within 15 minutes after vehicle stopped, read the values that are displayed for "AIR PRESS FL", "AIR PRESS FR", "AIR PRESS RR", and "AIR PRESS RL". C

Which tire pressures is displayed as 438.60 kPa (4.47 kg/cm<sup>2</sup>, 63.60 psi)?

- YES >> Replace tire pressure sensor the tire pressure as 438.60 kPa (4.47 kg/cm<sup>2</sup>, 63.60 psi) displayed. Refer to [WT-60. "Removal and Installation"](#). D
- NO >> Perform "DTC CONFIRMATION PROCEDURE" (self-diagnosis) again. Refer to [WT-30. "DTC Logic"](#).

WT

F

G

H

I

J

K

L

M

N

O

P

# C1728 RECEIVER ID

< DTC/CIRCUIT DIAGNOSIS >

## C1728 RECEIVER ID

### DTC Logic

INFOID:000000008134866

### DTC DETECTION LOGIC

DTC	Display Item	Malfunction detected condition	Possible causes
C1728	RECEIVER ID NO REG	Receiver ID registration cannot be performed.	<ul style="list-style-type: none"> <li>Tire pressure receiver malfunction</li> <li>Low tire pressure warning control unit malfunction</li> </ul>

### DTC CONFIRMATION PROCEDURE

#### 1. PERFORM DTC CONFIRMATION

##### With CONSULT

- Drive for 3 minutes at a speed of 40 km/h (25 MPH) or more, then drive normally for 10 minutes.
- Stop the vehicle.
- Perform self-diagnosis for "AIR PRESSURE MONITOR".

##### Is DTC "C1728" detected?

- YES >> Proceed to [WT-32, "Diagnosis Procedure"](#).  
 NO >> INSPECTION END

### Diagnosis Procedure

INFOID:000000008134867

#### 1. CHECK TIRE PRESSURE RECEIVER INPUT SIGNAL

- Turn the ignition switch ON.

##### **CAUTION:**

**Never start engine.**

- Use an oscilloscope and check the input signal waveform between the low tire pressure warning control unit harness connector and ground.

##### STANDBY STATUS

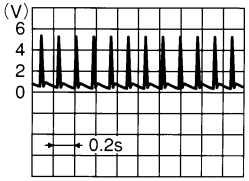
Low tire pressure warning control unit		—	Value (Approx.)
Connector	Terminal		
M43	3	Ground	 <p>Approx. 4.5 V</p>
	4		
	5		
	6		

##### WHEN SIGNAL IS RECEIVED

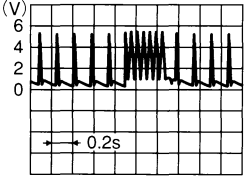
Low tire pressure warning control unit		—	Value (Approx.)
Connector	Terminal		
M43	3	Ground	 <p>Approx. 4.5 V</p>
	4		
	5		
	6		

##### Is the inspection result normal?



# C1728 RECEIVER ID

## < DTC/CIRCUIT DIAGNOSIS >

- YES >> Check connector for loose connection and then perform "DTC CONFIRMATION PROCEDURE" (self-diagnosis) again. Refer to [WT-32, "DTC Logic"](#).
- NO >> GO TO 2.

### 2.CHECK TIRE PRESSURE RECEIVER POWER SUPPLY CIRCUIT

1. Disconnect the tire pressure receiver harness connector.
2. Turn the ignition switch ON.  
**CAUTION:**  
**Never start the engine.**
3. Check the voltage between tire pressure receiver harness connector and ground.

Tire pressure receiver		—	Voltage
Connector	Terminal		
E58 (Front LH)	1	Ground	Approx. 7 - 16 V
E28 (Front RH)			
B13 (Rear LH)			
B213 (Rear RH)			

Is the inspection result normal?

- YES >> GO TO 3.
- NO >> Repair or replace the malfunctioning harness or connector.

### 3.CHECK TIRE PRESSURE RECEIVER GROUND CIRCUIT

1. Turn the ignition switch OFF.
2. Disconnect low tire pressure warning control unit harness connector and tire pressure receiver harness connector.
3. Check the continuity between low tire pressure warning control unit harness connector and tire pressure receiver harness connector.

Low tire pressure warning control unit		Tire pressure receiver		Continuity
Connector	Terminal	Connector	Terminal	
M43	26	E58 (Front LH)	4	Existed
	25	E28 (Front RH)		
	24	B13 (Rear LH)		
	23	B213 (Rear RH)		

Is the inspection result normal?

- YES >> GO TO 4.
- NO >> Repair or replace the malfunctioning harness or connector.

### 4.CHECK LOW TIRE PRESSURE WARNING CONTROL UNIT CIRCUIT

Check the low tire pressure warning control unit circuit. Refer to [WT-38, "Diagnosis Procedure"](#).

Is the low tire pressure warning control unit circuit normal?

- YES >> Replace the tire pressure receiver. Refer to [WT-62, "FRONT TIRE PRESSURE RECEIVER : Removal and Installation"](#) (Front), [WT-62, "REAR TIRE PRESSURE RECEIVER : Removal and Installation"](#) (Rear).
- NO >> Repair or replace error-detected parts.

# C1729 VEHICLE SPEED SIGNAL

< DTC/CIRCUIT DIAGNOSIS >

## C1729 VEHICLE SPEED SIGNAL

### DTC Logic

INFOID:000000008134868

### DTC DETECTION LOGIC

DTC	Display Item	Malfunction detected condition	Possible causes
C1729	VHCL SPEED SIG ERR	Vehicle speed signal not detected.	<ul style="list-style-type: none"><li>CAN communication malfunction</li><li>Low tire pressure warning control unit malfunction</li><li>ABS actuator and electric unit (control unit) malfunction</li></ul>

### DTC CONFIRMATION PROCEDURE

#### 1. DTC CONFIRMATION PROCEDURE

##### With CONSULT

- Drive for 3 minutes at a speed of 40 km/h (25 MPH) or more without stopping.
- Stop the vehicle.
- Perform self-diagnosis for "AIR PRESSURE MONITOR".

##### Is DTC "C1729" detected?

YES >> Proceed to [WT-34, "Diagnosis Procedure"](#).

NO >> INSPECTION END

### Diagnosis Procedure

INFOID:000000008134869

#### 1. PERFORM ABS ACTUATOR AND ELECTRIC UNIT (CONTROL UNIT) SELF-DIAGNOSIS

##### With CONSULT

Perform self-diagnosis for "ABS".

##### Is any DTC detected?

YES >> Check malfunctioning circuit.

NO >> GO TO 2.

#### 2. CHECK LOW TIRE PRESSURE WARNING CONTROL UNIT INPUT/OUTPUT SIGNAL

Check the low tire pressure warning control unit input/output signal values. Refer to [WT-13, "Reference Value"](#).

##### Is the inspection result normal?

YES >> Check pin terminal and connection of each harness connector for malfunctioning conditions.

NO >> Replace the low tire pressure warning control unit. Refer to [WT-59, "Removal and Installation"](#).

# C1750, C1751, C1752, C1753 RECEIVER

< DTC/CIRCUIT DIAGNOSIS >

## C1750, C1751, C1752, C1753 RECEIVER

### DTC Logic

INFOID:000000008134870

### DTC DETECTION LOGIC

DTC	Display Item	Malfunction detected condition	Possible causes
C1750	[RECEIVER ERR] FL	The front LH tire pressure receiver dose not receive a signal.	Tire pressure receiver malfunction
C1751	[RECEIVER ERR] FR	The front RH tire pressure receiver dose not receive a signal.	
C1752	[RECEIVER ERR] RR	The rear RH tire pressure receiver dose not receive a signal.	
C1753	[RECEIVER ERR] RL	The rear LH tire pressure receiver dose not receive a signal.	

### DTC CONFIRMATION PROCEDURE

#### 1. PERFORM DTC CONFIRMATION

##### With CONSULT

1. Drive for 3 minutes at a speed of 40 km/h (25 MPH) or more, then drive normally for 10 minutes.
2. Stop the vehicle.
3. Perform self-diagnosis for "AIR PRESSURE MONITOR".

Is DTC "C1750", "C1751", "C1752", or "C1753" detected?

- YES >> Proceed to [WT-35. "Diagnosis Procedure"](#).  
 NO >> INSPECTION END

### Diagnosis Procedure

INFOID:000000008134871

#### 1. CHECK TIRE PRESSURE RECEIVER INPUT SIGNAL

1. Turn the ignition switch ON.

##### **CAUTION:**

**Never start engine.**

2. Use an oscilloscope and check the input signal waveform between the low tire pressure warning control unit harness connector and ground.

##### STANDBY STATUS

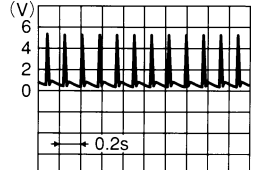
Low tire pressure warning control unit		—	Value (Approx.)
Connector	Terminal		
M43	3	Ground	 <p>OCC3879D Approx. 4.5 V</p>
	4		
	5		
	6		

# C1750, C1751, C1752, C1753 RECEIVER

## < DTC/CIRCUIT DIAGNOSIS >

### WHEN SIGNAL IS RECEIVED

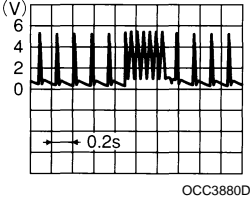
Low tire pressure warning control unit		—	Value (Approx.)
Connector	Terminal		
M43	3	Ground	 Approx. 4.5 V
	4		
	5		
	6		

#### Is the inspection result normal?

- YES >> Check connector for loose connection and then perform "DTC CONFIRMATION PROCEDURE" (self-diagnosis) again. Refer to [WT-35, "DTC Logic"](#).
- NO >> GO TO 2.

### 2. CHECK TIRE PRESSURE RECEIVER POWER SUPPLY CIRCUIT

1. Disconnect the tire pressure receiver harness connector.
2. Turn the ignition switch ON.  
**CAUTION:**  
**Never start the engine.**
3. Check the voltage between tire pressure receiver harness connector and ground.

Tire pressure receiver		—	Voltage
Connector	Terminal		
E58 (Front LH)	1	Ground	Approx. 7 - 16 V
E28 (Front RH)			
B13 (Rear LH)			
B213 (Rear RH)			

#### Is the inspection result normal?

- YES >> GO TO 3.
- NO >> Repair or replace the malfunctioning harness or connector.

### 3. CHECK TIRE PRESSURE RECEIVER GROUND CIRCUIT

1. Turn the ignition switch OFF.
2. Disconnect low tire pressure warning control unit harness connector and tire pressure receiver harness connector.
3. Check the continuity between low tire pressure warning control unit harness connector and tire pressure receiver harness connector.

Low tire pressure warning control unit		Tire pressure receiver		Continuity
Connector	Terminal	Connector	Terminal	
M43	26	E58 (Front LH)	4	Existed
	25	E28 (Front RH)		
	24	B13 (Rear LH)		
	23	B213 (Rear RH)		

#### Is the inspection result normal?

- YES >> GO TO 4.
- NO >> Repair or replace the malfunctioning harness or connector.

### 4. CHECK FOR CHANGE TO THE TIRE PRESSURE RECEIVER INSTALLATION POSITION (EXAMPLE: FRONT LH RECEIVER OK/NG JUDGMENT)

#### NOTE:

Example: Front LH tire pressure receiver OK/NG judgment when DTC "C1750" is detected.

## C1750, C1751, C1752, C1753 RECEIVER

### < DTC/CIRCUIT DIAGNOSIS >

---

#### With CONSULT

1. Exchange the positions of the front LH tire pressure receiver and the front RH tire pressure receiver.
2. Perform "DTC CONFIRMATION PROCEDURE" (self-diagnosis) again. Refer to [WT-35, "DTC Logic"](#).

#### Is DTC "C1751" detected?

- YES >> Replace the exchanged front RH tire pressure receiver.
- NO >> Check the low tire pressure warning control unit circuit. Refer to [WT-38, "Diagnosis Procedure"](#).

A  
B  
C  
D  
WT  
F  
G  
H  
I  
J  
K  
L  
M  
N  
O  
P

# C1754 LOW TIRE PRESSURE WARNING CONTROL UNIT

< DTC/CIRCUIT DIAGNOSIS >

## C1754 LOW TIRE PRESSURE WARNING CONTROL UNIT

DTC Logic

INFOID:000000008134872

### DTC DETECTION LOGIC

DTC	Display Item	Malfunction detected condition	Possible causes
C1754	CONT UNIT (EEPROM)	Memory (EEPROM) system malfunction is detected in the low tire pressure warning control unit	Low tire pressure warning control unit malfunction

### DTC CONFIRMATION PROCEDURE

#### 1. PERFORM DTC CONFIRMATION

##### With CONSULT

1. Drive for 3 minutes at a speed of 40 km/h (25 MPH) or more without stopping.
2. Stop the vehicle.
3. Perform self-diagnosis for "AIR PRESSURE MONITOR".

##### Is DTC "C1754" detected?

- YES >> Proceed to [WT-38, "Diagnosis Procedure"](#).  
 NO >> INSPECTION END

### Diagnosis Procedure

INFOID:000000008134873

#### 1. CHECK LOW TIRE PRESSURE WARNING CONTROL UNIT POWER SUPPLY AND GROUND CIRCUIT

Perform the trouble diagnosis for power supply and ground circuit. Refer to [WT-44, "Diagnosis Procedure"](#).

##### Is the inspection result normal?

- YES >> GO TO 2.  
 NO >> Repair or replace error-detected parts.

#### 2. CHECK TIRE PRESSURE RECEIVER CIRCUIT

1. Disconnect the tire pressure receiver harness connector.
2. Check the continuity between the low tire pressure warning control unit harness connector and tire pressure receiver harness connector.

Low tire pressure warning control unit		Tire pressure receiver		Continuity
Connector	Terminal	Connector	Terminal	
M43	6	E58 (Front LH)	3	Existed
	22		2	
	10		1	
	26		4	
	5	E28 (Front RH)	3	
	21		2	
	9		1	
	25		4	
	4	B13 (Rear LH)	3	
	20		2	
	8		1	
	24		4	
	3	B213 (Rear RH)	3	
	19		2	
	7		1	
	23		4	

# C1754 LOW TIRE PRESSURE WARNING CONTROL UNIT

## < DTC/CIRCUIT DIAGNOSIS >

3. Check the continuity between the low tire pressure warning control unit harness connector and ground.

Low tire pressure warning control unit		—	Continuity
Connector	Terminal		
M43	6	Ground	Not existed
	22		
	10		
	26		
	5		
	21		
	9		
	25		
	4		
	20		
	8		
	24		
	3		
	19		
	7		
23			

Is the inspection result normal?

YES >> GO TO 3.

NO >> Repair or replace the malfunctioning harness or connector.

### 3.PERFORM SELF-DIAGNOSIS AGAIN

#### With CONSULT

1. Check the tire pressure for all wheels and adjust to the specified value. Refer to [WT-63. "Tire Air Pressure"](#).
2. Perform tire pressure sensor ID registration for all wheels. Refer to [WT-23. "Work Procedure"](#).
3. Perform "DTC CONFIRMATION PROCEDURE" (self-diagnosis) again. Refer to [WT-38. "DTC Logic"](#).

Is DTC "C1754" detected?

YES >> Replace the low tire pressure warning control unit. Refer to [WT-59. "Removal and Installation"](#).

NO >> Check for looseness or damage at the harness connector pins of the low tire pressure warning control unit. Repair or replace if necessary.

# C1755, C1756, C1757, C1758 POOR RECEIVING CONDITIONS

< DTC/CIRCUIT DIAGNOSIS >

## C1755, C1756, C1757, C1758 POOR RECEIVING CONDITIONS

### DTC Logic

INFOID:000000008134874

### DTC DETECTION LOGIC

DTC	Display Item	Malfunction detected condition	Possible causes
C1755	PR RECEIV COND FL	The data signal from the front LH wheel tire pressure sensor cannot be detected due to external electromagnetic interference for 10 minutes or more. (DTC C1708 is displayed at the same time.)	External electromagnetic interference
C1756	PR RECEIV COND FR	The data signal from the front RH wheel tire pressure sensor cannot be detected due to external electromagnetic interference for 10 minutes or more. (DTC C1709 is displayed at the same time.)	
C1757	PR RECEIV COND RR	The data signal from the rear RH wheel tire pressure sensor cannot be detected due to external electromagnetic interference for 10 minutes or more. (DTC C1710 is displayed at the same time.)	
C1758	PR RECEIV COND RL	The data signal from the rear LH wheel tire pressure sensor cannot be detected due to external electromagnetic interference for 10 minutes or more. (DTC C1711 is displayed at the same time.)	

#### CAUTION:

If DTC C1755, C1756, C1757, or C1758 is detected along with, C1708, C1709, C1710, or C1711 first diagnose C1755, C1756, C1757, or C1758.

### DTC CONFIRMATION PROCEDURE

#### 1. PERFORM DTC CONFIRMATION

##### With CONSULT

1. Drive for 3 minutes at a speed of 40 km/h (25 MPH) or more, then drive normally for 10 minutes.
2. Stop the vehicle.
3. Perform self-diagnosis for "AIR PRESSURE MONITOR".

Is DTC "C1755", "C1756", "C1757", or "C1758" detected?

YES >> Proceed to [WT-40. "Diagnosis Procedure"](#).

NO >> INSPECTION END

### Diagnosis Procedure

INFOID:000000008134875

#### 1. TIRE PRESSURE SENSOR ID REGISTRATION

Perform tire pressure sensor ID registration. Refer to [WT-23. "Work Procedure"](#).

Is tire pressure sensor ID registration completed?

YES >> GO TO 2.

NO >> Change the work location and perform ID registration again, then proceed to [WT-52. "Diagnosis Procedure"](#).

#### 2. CHECK TIRE PRESSURE SIGNAL

##### With CONSULT

1. Drive for 3 minutes at a speed of 40 km/h (25 MPH) or more, then drive normally for 10 minutes.
2. Stop the vehicle.
3. Select "DATA MONITOR" for "AIR PRESSURE MONITOR" with CONSULT.
4. Within 5 minutes after vehicle stopped, check that the tire pressures match the standard value.

Monitor item	Displayed value
AIR PRESS FL	Approximately equal to the indication on tire gauge value for front LH tire
AIR PRESS FR	Approximately equal to the indication on tire gauge value for front RH tire



# C1755, C1756, C1757, C1758 POOR RECEIVING CONDITIONS

## < DTC/CIRCUIT DIAGNOSIS >

Monitor item	Displayed value
AIR PRESS RR	Approximately equal to the indication on tire gauge value for rear RH tire
AIR PRESS RL	Approximately equal to the indication on tire gauge value for rear LH tire

Is the inspection result normal?

YES >> GO TO 3.

NO >> Change the work location, then GO TO 1.

### 3. CHECK SELF-DIAGNOSIS RESULTS

#### With CONSULT

1. Erase the self-diagnosis memory for the low tire pressure warning control unit.
2. Turn ignition switch OFF, and wait for 10 seconds or more.
3. Perform "DTC CONFIRMATION PROCEDURE" (self-diagnosis) again. Refer to [WT-40, "DTC Logic"](#).

Are DTC "C1755", "C1756", "C1757", or "C1758" and "C1708", "C1709", "C1710", or "C1711" detected?

YES >> Change the work location, then GO TO 1.

NO >> Check the input/output signal values. Refer to [WT-13, "Reference Value"](#).

A  
B  
C  
D  
WT  
F  
G  
H  
I  
J  
K  
L  
M  
N  
O  
P

# U1000 CAN COMM CIRCUIT

< DTC/CIRCUIT DIAGNOSIS >

## U1000 CAN COMM CIRCUIT

### Description

INFOID:000000008134876

CAN (Controller Area Network) is a serial communication line for real time application. It is an on-vehicle multiplex communication line with high data communication speed and excellent error detection ability. Many electronic control units are equipped onto a vehicle, and each control unit shares information and links with other control units during operation (not independent). In CAN communication, control units are connected with 2 communication lines (CAN-H line, CAN-L line) allowing a high rate of information transmission with less wiring. Each control unit communicates data but selectively reads required data only.

### DTC Logic

INFOID:000000008134877

### DTC DETECTION LOGIC

DTC	Display item	Malfunction detected condition	Possible cause
U1000	CAN COMM CIRCUIT	Low tire pressure warning control unit is not communicating CAN communication signal for 2 seconds or more.	<ul style="list-style-type: none"><li>• CAN communication malfunction</li><li>• Malfunction of low tire pressure warning control unit</li></ul>

### DTC CONFIRMATION PROCEDURE

#### 1. PERFORM DTC CONFIRMATION

##### Ⓔ With CONSULT

1. Drive for several minutes at a speed of 40 km/h (25 MPH) or more.
2. Stop the vehicle.
3. Perform self-diagnosis for "AIR PRESSURE MONITOR".

Is DTC "U1000" detected?

- YES >> Proceed to [WT-42, "Diagnosis Procedure"](#).  
NO >> INSPECTION END

### Diagnosis Procedure

INFOID:000000008134878

Proceed to [LAN-36, "CAN COMMUNICATION SYSTEM : CAN System Specification Chart"](#).

# U1010 CONTROL UNIT (CAN)

< DTC/CIRCUIT DIAGNOSIS >

## U1010 CONTROL UNIT (CAN)

### Description

INFOID:000000008134879

CAN (Controller Area Network) is a serial communication line for real time application. It is an on-vehicle multiplex communication line with high data communication speed and excellent error detection ability. Many electronic control units are equipped onto a vehicle, and each control unit shares information and links with other control units during operation (not independent). In CAN communication, control units are connected with 2 communication lines (CAN-H line, CAN-L line) allowing a high rate of information transmission with less wiring. Each control unit communicates data but selectively reads required data only.

### DTC Logic

INFOID:000000008134880

### DTC DETECTION LOGIC

DTC	Display item	Malfunction detected condition	Possible cause
U1010	CONTROL UNIT (CAN)	Detecting error during the initial diagnosis of CAN controller of low tire pressure warning control unit.	Malfunction of low tire pressure warning control unit

### DTC CONFIRMATION PROCEDURE

#### 1. PERFORM DTC CONFIRMATION

##### With CONSULT

1. Drive for several minutes at a speed of 40 km/h (25 MPH) or more.
2. Stop the vehicle.
3. Perform self-diagnosis for "AIR PRESSURE MONITOR".

Is DTC "U1010" detected?

- YES >> Proceed to [WT-43, "Diagnosis Procedure"](#).  
NO >> INSPECTION END

### Diagnosis Procedure

INFOID:000000008134881

#### 1. CHECK LOW TIRE PRESSURE WARNING CONTROL UNIT

Check low tire pressure warning control unit harness connector for disconnection or deformation.

Is the inspection result normal?

- YES >> Replace low tire pressure warning control unit. Refer to [WT-59, "Removal and Installation"](#).  
NO >> Repair or replace error-detected parts.

# POWER SUPPLY AND GROUND CIRCUIT

< DTC/CIRCUIT DIAGNOSIS >

## POWER SUPPLY AND GROUND CIRCUIT

### Diagnosis Procedure

INFOID:000000008134882

#### 1. CHECK FUSE/FUSIBLE LINK

1. Turn the ignition switch OFF.
2. Check for fusing of the fuse and fusible link at the low tire pressure warning control unit.

- Check the 10A fuse [No. 3 in fuse block (J/B)]

Is the inspection result normal?

YES >> GO TO 2.

NO >> Repair or replace error-detected parts.

#### 2. CHECK LOW TIRE PRESSURE WARNING CONTROL UNIT POWER SUPPLY CIRCUIT

1. Disconnect the low tire pressure warning control unit harness connector.
2. Turn the ignition switch ON.

**CAUTION:**

**Never start engine.**

3. Check the voltage between the low tire pressure warning control unit and ground.

Low tire pressure warning control unit		—	Voltage
Connector	Terminal		
M43	15	Ground	Battery voltage

4. Turn the ignition switch OFF.
5. Check the voltage between the low tire pressure warning control unit and ground.

Low tire pressure warning control unit		—	Voltage (Approx.)
Connector	Terminal		
M43	15	Ground	0 V

Is the inspection result normal?

YES >> GO TO 3.

NO >> Check the following. If any items are damaged, repair or replace damaged parts.

- Harness for short or open between ignition switch and low tire pressure warning control unit harness connector
- Ignition voltage.

#### 3. CHECK LOW TIRE PRESSURE WARNING CONTROL UNIT GROUND CIRCUIT

1. Turn the ignition switch OFF.
2. Check the continuity between the low tire pressure warning control unit harness connector and ground.

Low tire pressure warning control unit		—	Continuity
Connector	Terminal		
M43	32	Ground	Existed

- Also check harness for short to ground and short to power.

Is the inspection result normal?

YES >> INSPECTION END

NO >> Repair open circuit or short to ground or short to power in harness or connectors.

# LOW TIRE PRESSURE WARNING LAMP

< DTC/CIRCUIT DIAGNOSIS >

## LOW TIRE PRESSURE WARNING LAMP

### Component Function Check

INFOID:000000008134883

#### 1. CHECK LOW TIRE PRESSURE WARNING LAMP OPERATION

Check that the low tire pressure warning lamp is turned OFF after turns ON for approximately 1 second, when the ignition switch is turned ON.

Is the inspection result normal?

- YES >> INSPECTION END
- NO >> Proceed to [WT-45, "Diagnosis Procedure"](#).

### Diagnosis Procedure

INFOID:000000008134884

#### 1. CHECK LOW TIRE PRESSURE WARNING CONTROL UNIT POWER SUPPLY AND GROUND CIRCUIT

Perform the trouble diagnosis for power supply and ground circuit. Refer to [WT-44, "Diagnosis Procedure"](#).

Is the inspection result normal?

- YES >> GO TO 2.
- NO >> Repair or replace error-detected parts.

#### 2. PERFORM LOW TIRE PRESSURE WARNING CONTROL UNIT SELF-DIAGNOSIS

 **With CONSULT**

1. Drive for several minutes at a speed of 40 km/h (25 MPH) or more.
2. Stop the vehicle.
3. Perform self-diagnosis for "AIR PRESSURE MONITOR".

Is any DTC detected?

- YES >> Perform trouble diagnosis for detected DTC. Refer to [WT-17, "DTC Index"](#).
- NO >> GO TO 3.

#### 3. CHECK LOW TIRE PRESSURE WARNING LAMP SIGNAL

 **With CONSULT**

1. Turn the ignition switch ON.  
**CAUTION:**  
**Never start engine.**
2. Select "DATA MONITOR" for "AIR PRESSURE MONITOR" with CONSULT.
3. Read out the value of "WARNING LAMP". For low tire pressure warning lamp condition, refer to "LOW TIRE PRESSURE WARNING LAMP CONTROL CONDITION" in [WT-9, "System Description"](#).

Does the data monitor display change normal?

- YES >> GO TO 4.
- NO >> Replace the low tire pressure warning control unit. Refer to [WT-59, "Removal and Installation"](#).

#### 4. CHECK COMBINATION METER POWER SUPPLY CIRCUIT

Perform the trouble diagnosis for combination meter power supply circuit. Refer to [MWI-59, "COMBINATION METER : Diagnosis Procedure"](#).

Is the inspection result normal?

- YES >> INSPECTION END
- NO >> Repair or replace error-detected parts.

A  
B  
C  
D  
WT  
F  
G  
H  
I  
J  
K  
L  
M  
N  
O  
P

# TPMS SYMPTOMS

< SYMPTOM DIAGNOSIS >

---

## SYMPTOM DIAGNOSIS

### TPMS SYMPTOMS















Symptom Table

*INFOID:000000008134885*

LOW TIRE PRESSURE WARNING LAMP SYMPTOM CHART

# TPMS SYMPTOMS

## < SYMPTOM DIAGNOSIS >

Diagnosis items	Symptom (Ignition switch ON)	Low tire pressure warning lamp	Cause	Action
Low tire pressure warning lamp	The low tire pressure warning lamp illuminates for 1 second, then turns OFF.	  ON 1 sec > stays OFF <small>SEIA0592E</small>	Wake-up operation for all tire pressure sensors at wheels is completed.	No procedure. (No system malfunctions)
	The low tire pressure warning lamp repeats blinking ON for 2 seconds and OFF for 0.2 seconds.	 Blinks:  ON 2 sec > OFF 0.2 sec <small>SEIA0593E</small>	Wake-up operation for all tire pressure sensors at wheels is not completed.	Perform the wake-up operation for all tire pressure sensors at wheels. Refer to <a href="#">WT-22, "Work Procedure"</a> .
	The low tire pressure warning lamp blinks once.	 Blinks 1 time ON 0.3 sec > OFF 1.0 sec <small>JPEIC0090GB</small>	The front LH wheel tire pressure sensor is not activated.	Perform the wake-up operation for the tire pressure sensor at front LH wheel. Refer to <a href="#">WT-22, "Work Procedure"</a> .
	The low tire pressure warning lamp repeats blinking twice.	  Blinks 2 times ON 0.3 sec > OFF 0.3 sec <small>SEIA0595E</small>	The front right wheel tire pressure sensor is not activated.	Perform the wake-up operation for the tire pressure sensor at front right wheel. Refer to <a href="#">WT-22, "Work Procedure"</a> .
	The low tire pressure warning lamp repeats blinking for 3 times.	   Blinks 3 times ON 0.3 sec > OFF 0.3 sec <small>SEIA0596E</small>	The rear right wheel tire pressure sensor is not activated.	Perform the wake-up operation for the tire pressure sensor at rear right wheel. Refer to <a href="#">WT-22, "Work Procedure"</a> .
	The low tire pressure warning lamp repeats blinking for 4 times.	    Blinks 4 times ON 0.3 sec > OFF 0.3 sec <small>SEIA0597E</small>	The rear LH wheel tire pressure sensor is not activated.	Perform the wake-up operation for the tire pressure sensor at rear LH wheel. Refer to <a href="#">WT-22, "Work Procedure"</a> .
	The low tire pressure warning lamp turns ON and stays illuminated.	 Comes ON and stays ON <small>SEIA0598E</small>	Low tire pressure	Check the tire pressure for all wheels and adjust to the specified value. Refer to <a href="#">WT-63, "Tire Air Pressure"</a> .

A

B

C

D

WT

F

G

H

I

J

K

L

M

N

O

P

# TPMS SYMPTOMS

## < SYMPTOM DIAGNOSIS >

Diagnosis items	Symptom (Ignition switch ON)	Low tire pressure warning lamp	Cause	Action
Low tire pressure warning lamp	The low tire pressure warning lamp repeats blinking at 0.5-second intervals for 1 minute, and then stays illuminated.	 <p style="text-align: center;">Blinks 1 min</p> <p style="text-align: center;">ON 0.5 sec &gt; OFF 0.5 sec and stays ON</p> <p style="text-align: center;"><small>SEIA0788E</small></p>	The combination meter fuse is open or removed (or pulled out).	Check and install the combination meter fuse. If necessary, replace the fuse.
			The low tire pressure warning control unit harness connector is removed.	Check the connection conditions of the low tire pressure warning control unit harness connector, and repair if necessary.
			Tire Pressure Monitoring System (TPMS) malfunction.	<ul style="list-style-type: none"> <li>Perform self-diagnosis.</li> <li>If necessary, perform tire pressure sensor ID registration. Refer to <a href="#">WT-23, "Work Procedure"</a>.</li> </ul>
Hazard warning lamp	The hazard warning lamp does not blink twice when the tire pressure sensor is activated. Or the buzzer does not sound.	—	<ul style="list-style-type: none"> <li>The tire pressure sensor activation tool does not activate.</li> </ul>	<ul style="list-style-type: none"> <li>Replace the battery in the tire pressure sensor activation tool.</li> </ul>
			<ul style="list-style-type: none"> <li>The ignition switch is OFF when the tire pressure sensor wake-up operation is performed.</li> </ul>	<ul style="list-style-type: none"> <li>Turn the ignition switch ON when performing the tire pressure sensor wake-up operation.</li> </ul>
			<ul style="list-style-type: none"> <li>The tire pressure sensor activation tool is not used in the correct position.</li> </ul>	<ul style="list-style-type: none"> <li>Operate the tire pressure sensor activation tool in the correct position when performing the wake-up operation.</li> </ul>
			<ul style="list-style-type: none"> <li>The tire pressure sensor is already waked up.</li> </ul>	<ul style="list-style-type: none"> <li>No procedure.</li> </ul>

**NOTE:**

If tire pressure sensor wake-up operation is not completed for two or more tire pressure sensors, the applicable low tire pressure warning lamp blinking patterns are displayed continuously.  
(Example: Blinks once/OFF/blinks 3 times = Wake-up operation is not completed at the front LH wheel and rear RH wheel tire pressure sensors.)



# LOW TIRE PRESSURE WARNING LAMP DOES NOT TURN ON

< SYMPTOM DIAGNOSIS >

## LOW TIRE PRESSURE WARNING LAMP DOES NOT TURN ON

### Description

INFOID:000000008134886

The low tire pressure warning lamp does not illuminate when the ignition switch is turned ON.

#### NOTE:

The low tire pressure warning lamp illuminates for approximately 1 second and then turns OFF when the ignition switch is turned ON. This is to check that no abnormal condition is present in the tire pressure monitoring system.

The lamp bulb may be burnt out or the tire pressure monitoring system may be malfunctioning if the low tire pressure warning lamp does not illuminate when the ignition switch is turned ON.

### Diagnosis Procedure

INFOID:000000008134887

#### 1. CHECK LOW TIRE PRESSURE WARNING LAMP

Perform trouble diagnosis for the low tire pressure warning lamp. Refer to [WT-45, "Diagnosis Procedure"](#).

Is the inspection result normal?

- YES >> Check each harness connector pin terminal for malfunction or disconnection.
- NO >> Repair or replace error-detected parts.

A  
B  
C  
D  
E  
F  
G  
H  
I  
J  
K  
L  
M  
N  
O  
P

WT

# LOW TIRE PRESSURE WARNING LAMP DOES NOT TURN OFF

< SYMPTOM DIAGNOSIS >

---

## LOW TIRE PRESSURE WARNING LAMP DOES NOT TURN OFF

### Description

INFOID:000000008134888

The low tire pressure warning lamp does not turn OFF after several seconds is passed after engine starts.

### Diagnosis Procedure

INFOID:000000008134889

#### 1. CHECK TIRE PRESSURE

---

1. Turn the ignition switch ON.

**CAUTION:**

**Never start the engine.**

2. Check the tire pressure for all wheels and adjust to the specified value. Refer to [WT-63, "Tire Air Pressure"](#).

Is the inspection result normal?

YES >> GO TO 2.

NO >> Inspect or repair the tires or wheels.

#### 2. CHECK LOW TIRE PRESSURE WARNING LAMP

---

Check low tire pressure warning lamp display.

Does not low tire pressure warning lamp turn OFF?

YES >> GO TO 3.

NO >> INSPECTION END

#### 3. CHECK DTC WITH LOW TIRE PRESSURE WARNING CONTROL UNIT

---

**Ⓟ With CONSULT**

Perform self-diagnosis for "AIR PRESSURE MONITOR".

Is any DTC detected?

YES >> Perform the diagnosis applicable to the displayed DTC. Refer to [WT-17, "DTC Index"](#).

NO >> GO TO 4.

#### 4. CHECK LOW TIRE PRESSURE WARNING CONTROL UNIT POWER SUPPLY AND GROUND CIRCUIT

---

Perform the trouble diagnosis for power supply and ground circuit. Refer to [WT-44, "Diagnosis Procedure"](#).

Is the inspection result normal?

YES >> Replace low tire pressure warning control unit. Refer to [WT-59, "Removal and Installation"](#).

NO >> Repair or replace error-detected parts.

# LOW TIRE PRESSURE WARNING LAMP BLINKS

< SYMPTOM DIAGNOSIS >

## LOW TIRE PRESSURE WARNING LAMP BLINKS

### Description

INFOID:000000008134890

The low tire pressure warning lamp blinks when the ignition switch is turned ON.

#### NOTE:

The position of an inactive tire pressure sensor can be identified by checking the blinking timing of the low tire pressure warning lamp.

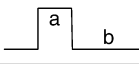
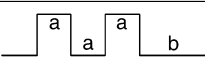
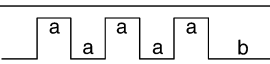
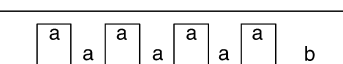
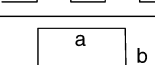
Low tire pressure warning lamp blinking timing		Activation tire position
ON OFF		Front LH
ON OFF		Front RH
ON OFF		Rear RH
ON OFF		Rear LH
ON OFF		All tires

JPEIC0089GB

### Diagnosis Procedure

INFOID:000000008134891

#### 1. TIRE PRESSURE SENSOR WAKE-UP OPERATION

Perform the tire pressure sensor wake-up. Refer to [WT-22, "Work Procedure"](#).

Is the tire pressure sensor wake-up completed?

YES >> GO TO 2.

NO >> Perform trouble diagnosis for the tire pressure sensor. Refer to [WT-26, "Diagnosis Procedure"](#).

#### 2. TIRE PRESSURE SENSOR ID REGISTRATION

Perform tire pressure sensor ID registration. Refer to [WT-23, "Work Procedure"](#).

Is tire pressure sensor ID registration completed?

YES >> INSPECTION END

NO >> Perform the self-diagnosis for "AIR PRESSURE MONITOR". Refer to [WT-17, "DTC Index"](#).

# ID REGISTRATION CANNOT BE COMPLETED

< SYMPTOM DIAGNOSIS >

---

## ID REGISTRATION CANNOT BE COMPLETED

### Description

INFOID:000000008134892

The ID of the tire pressure sensor installed in each wheel cannot be registered in the tire pressure monitoring system.

Inspect the tire pressure sensor or the tire pressure monitoring system circuit.

### Diagnosis Procedure

INFOID:000000008134893

---

#### 1. TIRE PRESSURE SENSOR WAKE-UP

Perform the tire pressure sensor wake-up. Refer to [WT-22. "Work Procedure"](#).

Is the tire pressure sensor wake-up completed?

YES >> GO TO 3.

NO >> GO TO 2.

---

#### 2. CHECK TIRE PRESSURE SENSOR ACTIVATION TOOL

Check tire pressure sensor activation tool.

Is the inspection result normal?

YES >> GO TO 3.

NO >> Replace the battery of tire pressure sensor activation tool or repair/replace the tire pressure sensor activation tool.

---

#### 3. TIRE PRESSURE SENSOR ID REGISTRATION

Perform tire pressure sensor ID registration. Refer to [WT-23. "Work Procedure"](#).

##### **CAUTION:**

**To perform ID registration, observe the following points:**

- **Never register ID in a place where radio waves are interfered (e.g. radio tower).**
- **Never register ID in a place close to vehicles including TPMS.**

Is tire pressure sensor ID registration completed?

YES >> INSPECTION END

NO >> GO TO 4.

---

#### 4. CHECK TIRE PRESSURE SIGNAL

Change the work location and perform ID registration again.

##### **NOTE:**

Depending on the tire pressure sensor position\*, a blind spot exists, and the tire pressure receiver gets a poor reception. If an ID registration is performed under this condition, the registration may not be completed. In such case, follow the instructions below to improve the radio wave receiving environment.

- Rotate tire by 90°, 180°, or 270°. (This Step is to change tire pressure sensor position.)
- Open the door close to the tire of which ID registration is ongoing.

\*: Radio wave reception condition depends on vehicle architecture (e.g. body harness layout, tire wheel design) or environment.

When ID registration is performed, which wheels do not react?

All wheels react and ID registration is possible.>>INSPECTION END

Only certain wheel(s) do not react.>>Replace applicable tire pressure sensor. Refer to [WT-60. "Removal and Installation"](#).

All wheels do not react.>>Check the tire pressure receiver. Refer to [WT-35. "Diagnosis Procedure"](#).

# HAZARD WARNING LAMP REMAINS ON

< SYMPTOM DIAGNOSIS >

## HAZARD WARNING LAMP REMAINS ON

### Description

INFOID:000000008134894

The hazard warning lamp remains on.

### Diagnosis Procedure

INFOID:000000008134895

#### 1. CHECK HAZARD WARNING LAMP OPERATION

Check hazard warning lamp operation with hazard switch.

Is the operation normal?

YES >> GO TO 2.

NO >> Perform trouble diagnosis for the hazard warning lamp. Refer to [EXL-92, "Diagnosis Procedure"](#).

#### 2. CHECK HAZARD REQUEST SIGNAL CIRCUIT

1. Turn the ignition switch OFF.
2. Disconnect the low tire pressure warning control unit connector, hazard warning lamp switch connector, and BCM connector.
3. Check the continuity between the low tire pressure warning control unit connector and the ground.

Low tire pressure warning control unit		—	Continuity
Connector	Terminal		
M43	30	Ground	Not existed

Is the inspection result normal?

YES >> Repair or replace the malfunctioning harness or connector.

NO >> Replace the low tire pressure warning control unit. Refer to [WT-59, "Removal and Installation"](#).

A  
B  
C  
D  
WT  
F  
G  
H  
I  
J  
K  
L  
M  
N  
O  
P

# NOISE, VIBRATION AND HARSHNESS (NVH) TROUBLESHOOTING

< SYMPTOM DIAGNOSIS >

## NOISE, VIBRATION AND HARSHNESS (NVH) TROUBLESHOOTING

### NVH Troubleshooting Chart

INFOID:000000008134896

Use the chart below to find the cause of the symptom. If necessary, repair or replace these parts.

Symptom		Possible cause and SUSPECTED PARTS	Reference																
			WT-57, "Exploded View"	WT-57, "Inspection"	WT-55, "Adjustment"	WT-63, "Tire Air Pressure"	WT-57, "Inspection"	—	—	WT-63, "Tire Air Pressure"	NVH in DLN section.	NVH in DLN section.	NVH in FAX and FSU sections.	NVH in RAX and RSU sections.	Refer to TIRES in this chart.	Refer to ROAD WHEEL in this chart.	NVH in FAX, RAX section.	NVH in BR section.	NVH in ST section.
Symptom	TIRES	Noise	x	x	x	x	x	x	x	x	x	x	x	x	x	x	x	x	x
		Shake	x	x	x	x	x	x	x	x	x	x	x	x	x	x	x	x	x
		Vibration				x				x	x		x	x					x
		Shimmy	x	x	x	x	x	x	x	x	x		x	x		x		x	x
		Judder	x	x	x	x	x	x		x			x	x		x		x	x
		Poor quality ride or handling	x	x	x	x	x	x		x			x		x	x			
	ROAD WHEEL	Noise	x	x	x				x		x	x	x	x	x		x	x	x
		Shake	x	x	x				x		x		x	x	x		x	x	x
		Shimmy, Judder	x	x	x				x				x	x	x			x	x
		Poor quality ride or handling	x	x	x				x				x	x	x				

x: Applicable

# ROAD WHEEL

< PERIODIC MAINTENANCE >

## PERIODIC MAINTENANCE

### ROAD WHEEL

#### Adjustment

INFOID:000000008134897

#### BALANCING WHEELS (BONDING WEIGHT TYPE)

##### Preparation Before Adjustment

Using releasing agent, remove double-faced adhesive tape from the road wheel.

##### **CAUTION:**

- **Be careful not to scratch the road wheel during removal.**
- **After removing double-faced adhesive tape, wipe clean traces of releasing agent from the road wheel.**

##### Wheel Balance Adjustment

- The details of the adjustment procedure are different for each model of wheel balancer. Therefore, refer to each instruction manual.
- If a tire balance machine has adhesion balance weight mode settings and drive-in weight mode setting, select and adjust a drive-in weight mode suitable for road wheels.

1. Set road wheel on tire balance machine using the center hole as a guide. Start the tire balance machine.
2. When inner and outer unbalance values are shown on the tire balance machine indicator, multiply outer unbalance value by  $5/3$  to determine balance weight that should be used. Select the outer balance weight with a value closest to the calculated value above and install to the designated outer position of, or at the designated angle in relation to the road wheel.

##### **CAUTION:**

- **Never install the inner balance weight before installing the outer balance weight.**
- **Before installing the balance weight, always to clean the mating surface of the road wheel.**

- a. Indicated unbalance value  $\times 5/3 =$  balance weight to be installed

##### **Calculation example:**

$23 \text{ g (0.81 oz)} \times 5/3 = 38.33 \text{ g (1.35 oz)} \Rightarrow 37.5 \text{ g (1.32 oz)}$  balance weight (closer to calculated balance weight value)

##### **NOTE:**

Note that balance weight value must be closer to the calculated balance weight value.

##### **Example:**

$36.2 \Rightarrow 35 \text{ g (1.23 oz)}$

$36.3 \Rightarrow 37.5 \text{ g (1.32 oz)}$

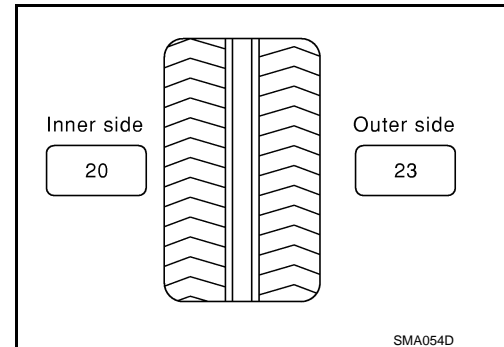

- b. Installed balance weight in the position.

A

B

C

D

WT

F

G

H

I

J

K

L

M

N

O

P

# ROAD WHEEL

## < PERIODIC MAINTENANCE >

- When installing balance weight (1) to road wheels, set it into the grooved area (A) on the inner wall of the road wheel as shown in the figure so that the balance weight center (B) is aligned with the tire balance machine indication position (angle) (C).

### CAUTION:

- Always use genuine NISSAN adhesion balance weights.
- Balance weights are non-reusable; always replace with new ones.
- Never install three or more sheets of balance weight.

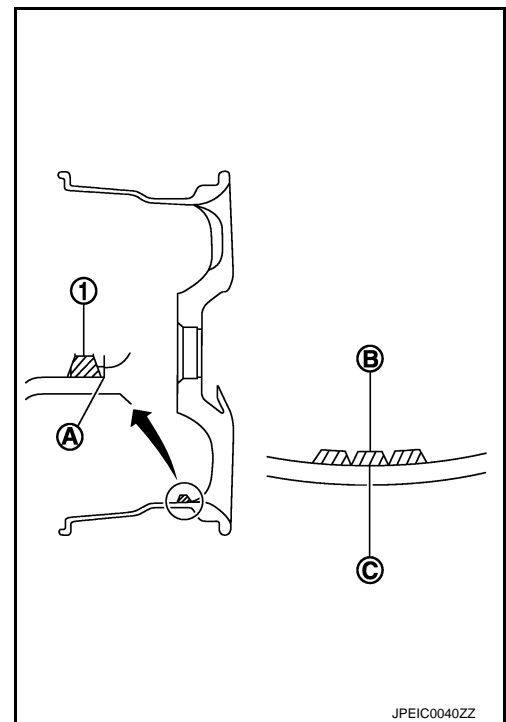

- If calculated balance weight value exceeds 50 g (1.76 oz), install two balance weight sheets in line with each other as shown in the figure.

### CAUTION:

**Never install one balance weight sheet on top of another.**

- Start the tire balance machine again.
- Install drive-in balance weight on inner side of road wheel in the tire balance machine indication position (angle).

### CAUTION:

**Never install three or more balance weight.**

- Start the tire balance machine. Check that the inner and outer residual unbalance value is within the allowable unbalance value.

### CAUTION:

**If either residual unbalance value exceeds limit, repeat installation procedures.**

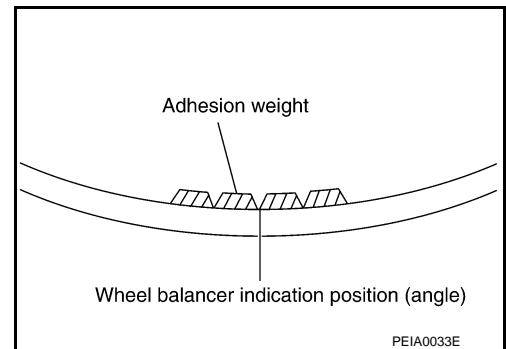

### Allowable unbalance value

**Dynamic (At flange) : Refer to [WT-63, "Road Wheel"](#).**

**Static (At flange) : Refer to [WT-63, "Road Wheel"](#).**

## TIRE ROTATION

- Follow the maintenance schedule for tire rotation service intervals. Refer to [MA-5, "FOR NORTH AMERICA : Explanation of General Maintenance"](#).
- When installing the wheel, tighten wheel nuts to the specified torque. Refer to [WT-57, "Exploded View"](#).

### CAUTION:

- Do not include the T-type spare tire when rotating the tires.
  - When installing wheels, tighten them diagonally by dividing the work two to three times in order to prevent the wheels from developing any distortion.
  - Be careful not to tighten wheel nut at torque exceeding the criteria.
  - Use NISSAN genuine wheel nuts for aluminum wheels.
- Perform the ID registration, after tire rotation. Refer to [WT-23, "Work Procedure"](#).

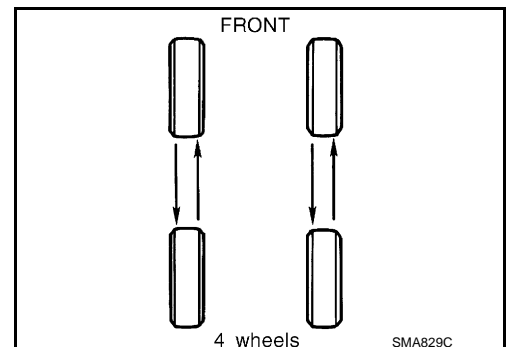



# ROAD WHEEL TIRE ASSEMBLY

< REMOVAL AND INSTALLATION >

## REMOVAL AND INSTALLATION

### ROAD WHEEL TIRE ASSEMBLY

Exploded View

INFOID:000000008134898

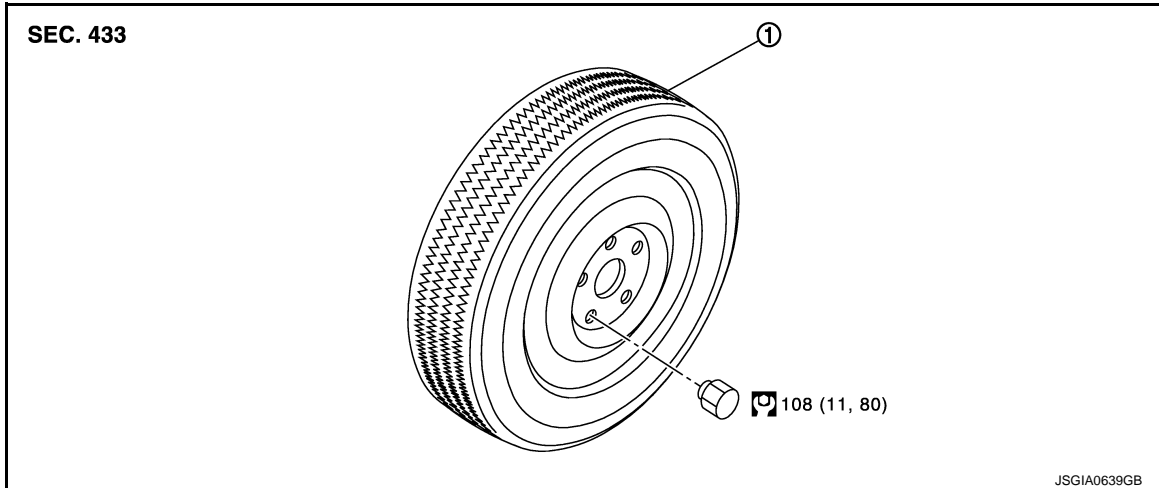

1. Tire assembly

Refer to [GI-4, "Components"](#) for symbols in the figure.

### Removal and Installation

INFOID:000000008134899

#### REMOVAL

1. Remove wheel nuts.
2. Remove tire assembly.

#### INSTALLATION

Note the following, install in the reverse order of removal.

- When replacing or rotating wheels, perform the ID registration. Refer to [WT-23, "Work Procedure"](#).

### Inspection

INFOID:000000008134900

#### ALUMINUM WHEEL

1. Check tires for wear and improper inflation.
2. Check wheels for deformation, cracks and other damage. If deformed, remove wheel and check wheel runout.
  - a. Remove tire from aluminum wheel and mount on a tire balance machine.
  - b. Set dial indicator as shown in the figure.
  - c. Check runout, if the axial runout (A) or radial runout (B) exceeds the limit, replace aluminum wheel.

#### Limit

**Axial runout (A)** : Refer to [WT-63, "Road Wheel"](#).

**Radial runout (B)** : Refer to [WT-63, "Road Wheel"](#).

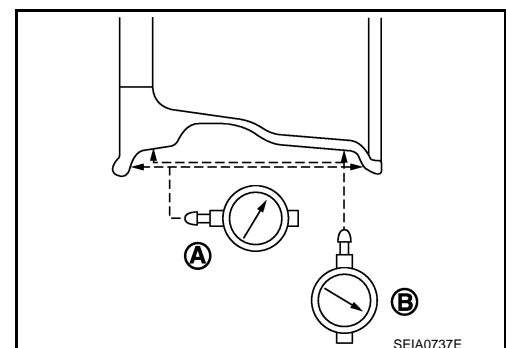

#### STEEL WHEEL

1. Check tires for wear and improper inflation.

## ROAD WHEEL TIRE ASSEMBLY

### < REMOVAL AND INSTALLATION >

2. Check wheels for deformation, clacks and other damage. If deformed, remove wheel and check wheel runout.
  - a. Remove tire from steel wheel and mount wheel on a tire balance machine.
  - b. Set two dial indicators as shown in the figure.
  - c. Set each dial indicator to "0".
  - d. Rotate wheel and check dial indicators at several points around the circumference of the wheel.
  - e. Calculate runout at each point as shown below.

$$\text{Axial runout (A)} : (\textcircled{1} + \textcircled{2}) / 2$$

$$\text{Radial runout (B)} : (\textcircled{3} + \textcircled{4}) / 2$$

- f. Select maximum positive runout value and the maximum negative value. Add the two values to determine total runout.

**CAUTION:**

**In case a positive or negative value is not available, use the maximum value (negative or positive) for total runout.**

**Limit**

**A** : Refer to [WT-63, "Road Wheel"](#).

**B** : Refer to [WT-63, "Road Wheel"](#).

- g. If the total runout value exceeds limit, replace steel wheel.

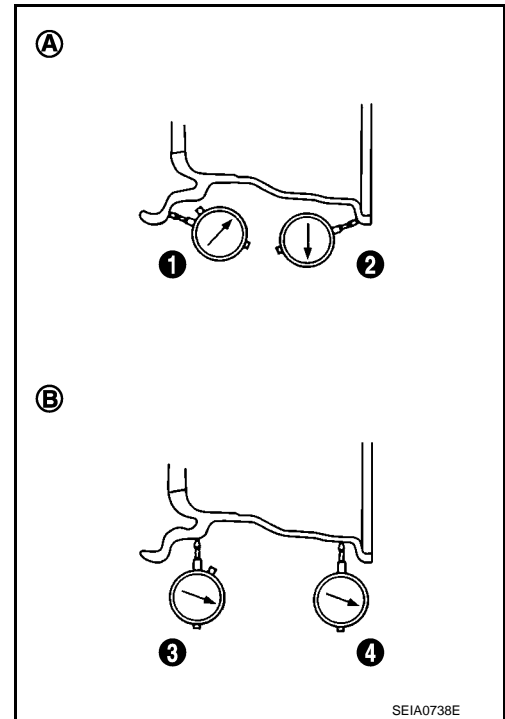

# LOW TIRE PRESSURE WARNING CONTROL UNIT

< REMOVAL AND INSTALLATION >

## LOW TIRE PRESSURE WARNING CONTROL UNIT

Exploded View

INFOID:000000008134901

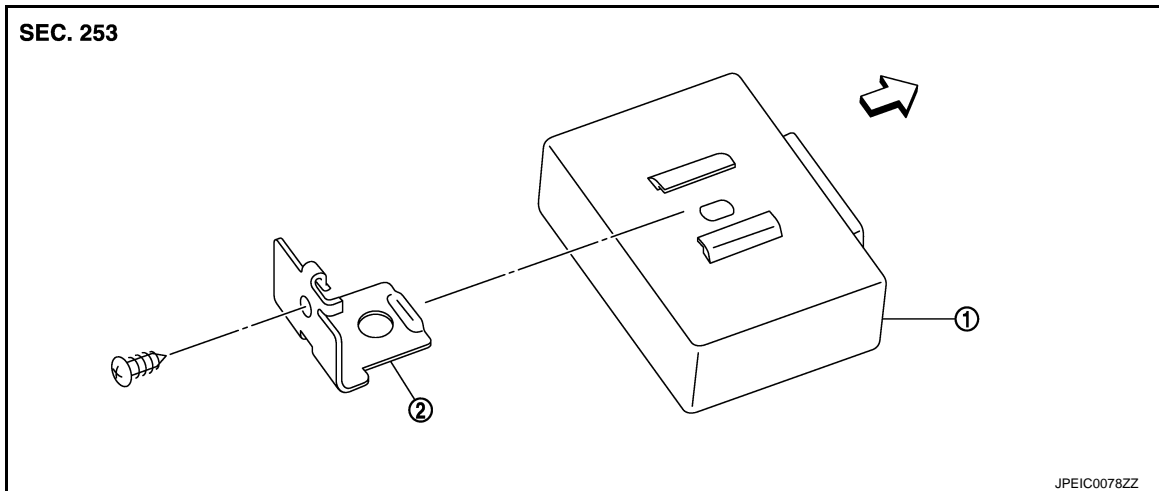

1. Low tire pressure warning control unit 2. Bracket

⇐: Vehicle front

Refer to [GI-4, "Components"](#) for symbols in the figure.

## Removal and Installation

INFOID:000000008134902

### REMOVAL

1. Remove the glove box assembly. Refer to [IP-13, "Removal and Installation"](#).
2. Remove the instrument lower panel RH. Refer to [IP-13, "Removal and Installation"](#).
3. Disconnect low tire pressure warning control unit connector.
4. Remove the low tire pressure warning control unit control unit.

### INSTALLATION

Note the following, and install in the reverse order of removal.

- Perform ID registration after replacing low tire pressure warning control unit. Refer to [WT-23, "Work Procedure"](#).

# TIRE PRESSURE SENSOR

< REMOVAL AND INSTALLATION >

## TIRE PRESSURE SENSOR

### Exploded View

INFOID:000000008134903

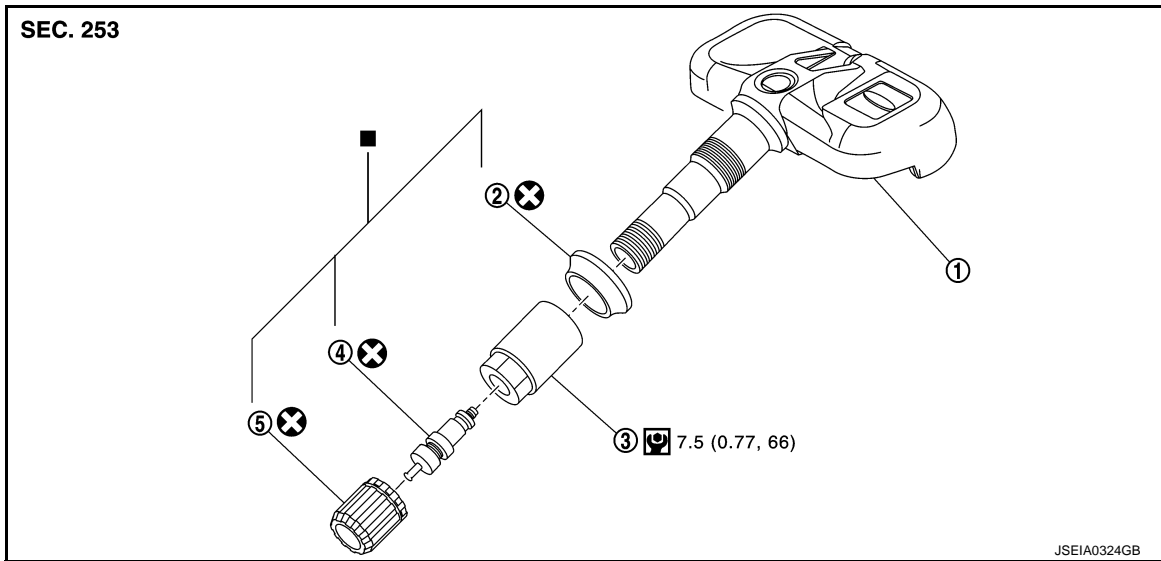

- |                         |                 |              |
|-------------------------|-----------------|--------------|
| 1. Tire pressure sensor | 2. Grommet seal | 3. Valve nut |
| 4. Valve core           | 5. Valve cap    |              |

■ : Parts that are replaced as a set when the tire is replaced.

Refer to [GI-4, "Components"](#) for symbols not described above.

### Removal and Installation

INFOID:000000008134904

#### REMOVAL

1. Remove tire assembly. Refer to [WT-57, "Removal and Installation"](#).
2. Remove valve cap, valve core and then deflate tire.

#### NOTE:

If the tire is reused, apply a matching mark to the position of the tire road wheel valve hole for the purpose of wheel balance adjustment after installation.

3. Remove valve nut retaining tire pressure sensor and allow tire pressure sensor to fall into tire.
4. Use the tire changer and disengage the tire beads.

#### CAUTION:

- Verify that the tire pressure sensor (1) is at the bottom of the tire while performing the above.
- Be sure not to damage the road wheel or tire pressure sensor.

5. Apply bead cream or an equivalent to the tire beads.
6. Set tire onto the tire changer turntable so that the tire pressure sensor inside the tire is located close to the road wheel valve hole.

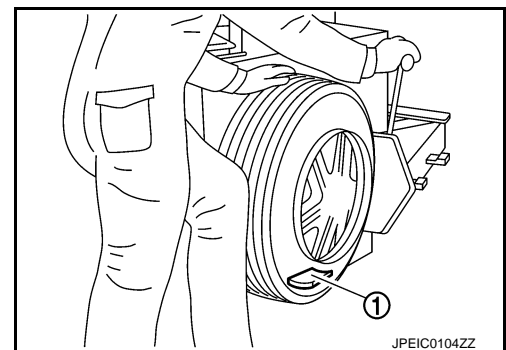

# TIRE PRESSURE SENSOR

## < REMOVAL AND INSTALLATION >

- Turn tire so that valve hole is at bottom and bounce so that tire pressure sensor (1) is near valve hole. Carefully lift tire onto turntable and position valve hole (and tire pressure sensor) 270 degree from mounting/dismounting head (2).

**CAUTION:**

**Be sure not to damage the road wheel and tire pressure sensor.**

- Remove tire pressure sensor from tire.
- Remove the grommet seal.

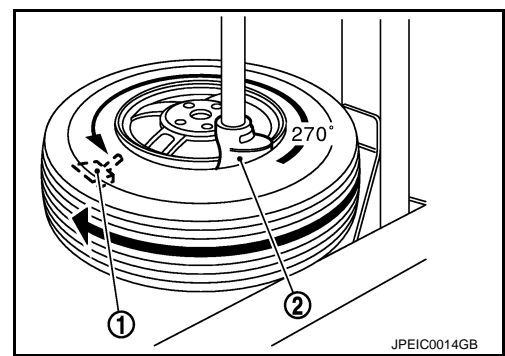

## INSTALLATION

- Apply bead cream or an equivalent to the tire beads.
- Install the tire inside beads (1) onto the road wheel (2) in the position shown in the figure.
- Install grommet seal to the tire pressure sensor.

**CAUTION:**

- Never reuse grommet seal.
- Insert grommet seal all the way to the base.

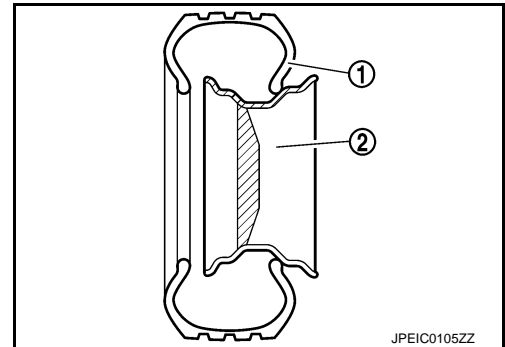

- Hold tire pressure sensor as shown in the figure, and press the sensor in the direction shown by arrow (←) to bring it into absolute contact with valve hole. After this, tighten valve nut to the specified torque.

**CAUTION:**

- Never reuse valve core and valve cap.
- Check that grommet seal is free of foreign matter.
- Check that grommet seal contacts horizontally with road wheel.
- Manually tighten valve nut all the way to the wheel. (Never use a power tool to avoid impact.)

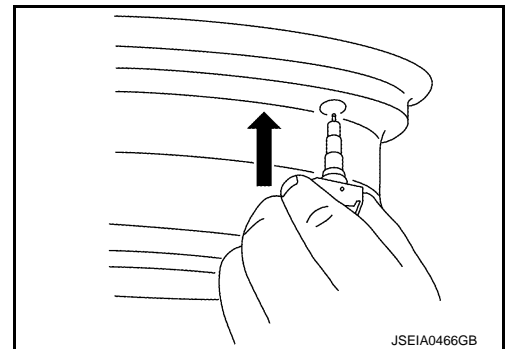

- Set the tire onto the turntable so that the tire changer arm (2) is at a position approximately 270° from the tire pressure sensor (1).

**CAUTION:**

**Be sure that the arm does not contact the tire pressure sensor.**

- Install the tire outer side beads onto the road wheel.

**CAUTION:**

**When installing, check that the tire does not turn together with the road wheel.**

- Check the tire pressure for all wheels and adjust to the specified value. Refer to [WT-63, "Tire Air Pressure"](#).

**NOTE:**

Before adding air, align the tire with the position of the matching mark applied at the time of removal.

- Install tire to the vehicle. Refer to [WT-57, "Removal and Installation"](#).
- Perform tire pressure sensor ID registration. Refer to [WT-23, "Work Procedure"](#).

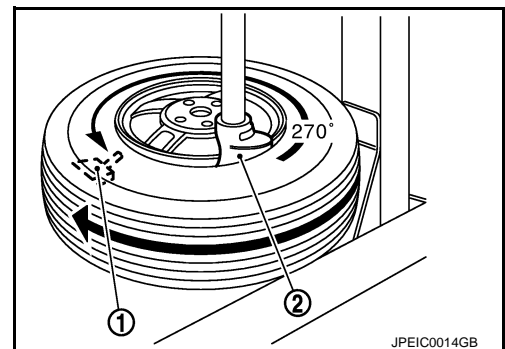

# TIRE PRESSURE RECEIVER

< REMOVAL AND INSTALLATION >

## TIRE PRESSURE RECEIVER

Exploded View

INFOID:000000008134905

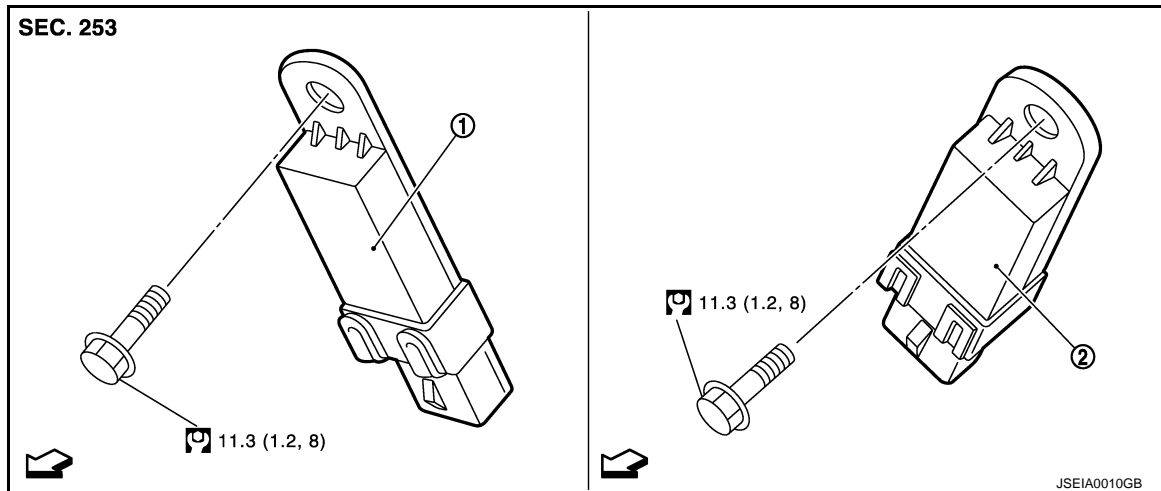

1. Front tire pressure receiver
2. Rear tire pressure receiver

↶: Vehicle front

Refer to [GI-4, "Components"](#) for symbols in the figure.

## FRONT TIRE PRESSURE RECEIVER

### FRONT TIRE PRESSURE RECEIVER : Removal and Installation

INFOID:000000008134906

#### REMOVAL

1. Remove fender protector (rear). Refer to [EXT-24, "FENDER PROTECTOR : Removal and Installation"](#).
2. Remove mounting bolt for the front tire pressure receiver.
3. Disconnect front tire pressure receiver harness connector.
4. Remove front tire pressure receiver.

#### INSTALLATION

Installation is the reverse order of removal.

## REAR TIRE PRESSURE RECEIVER

### REAR TIRE PRESSURE RECEIVER : Removal and Installation

INFOID:000000008134907

#### REMOVAL

1. Remove rear wheel house protector. Refer to [EXT-25, "REAR WHEEL HOUSE PROTECTOR : Removal and Installation"](#).
2. Remove mounting bolt for the rear tire pressure receiver.
3. Disconnect rear tire pressure receiver harness connector.
4. Remove rear tire pressure receiver.

#### INSTALLATION

Installation is the reverse order of removal.

# SERVICE DATA AND SPECIFICATIONS (SDS)

< SERVICE DATA AND SPECIFICATIONS (SDS)

## SERVICE DATA AND SPECIFICATIONS (SDS)

### SERVICE DATA AND SPECIFICATIONS (SDS)

#### Road Wheel

INFOID:000000008134908

#### CONVENTIONAL

Item		Limit
Runout	Axial runout	Less than 0.3 mm (0.012 in)
	Radial runout	
Allowable unbalance	Dynamic (At flange)	Less than 5 g (0.17 oz) (one side)
	Static (At flange)	Less than 10 g (0.35 oz)

#### EMERGENCY (ALUMINUM WHEEL)

Item		Limit
Runout	Axial runout	Less than 1.5 mm (0.059 in)
	Radial runout	

#### EMERGENCY (STEEL WHEEL)

Item		Limit
Runout	Axial runout (Average)	Less than 1.5 mm (0.059 in)
	Radial runout (Average)	

#### Tire Air Pressure

INFOID:000000008134909

Unit: kPa (kg/cm<sup>2</sup>, psi)

Tire size	Air pressure	
	Front	Rear
P245/50R18 99V	230 (2.3, 33)	
245/40R20 95W	230 (2.3, 33)	
T165/80R17 104M	420 (4.2, 60)	
T165/80D17 104M	420 (4.2, 60)	
T155/80R18 102M	420 (4.2, 60)	
T155/80D18 102M	420 (4.2, 60)	