

## SECTION **AT**

GI

MA

EM

LC

EC

FE

CL

MT

**AT**

FA

RA

BR

ST

RS

BT

HA

EL

IDX

## CONTENTS

<b>PREPARATION AND PRECAUTIONS</b> .....3	Diagnostic Procedure 15.....99
Special Service Tools.....3	Diagnostic Procedure 16.....100
Commercial Service Tools.....6	Diagnostic Procedure 17.....100
Service Notice.....7	Diagnostic Procedure 18.....101
Supplemental Restraint System (SRS) "AIR BAG".....8	Diagnostic Procedure 19.....101
<b>DESCRIPTION</b> .....9	Diagnostic Procedure 20.....101
Cross-sectional View.....9	Electrical Components Inspection.....102
Hydraulic Control Circuit.....10	Final Check.....109
Shift Mechanism.....11	Symptom Chart.....114
Control System.....13	<b>TROUBLE DIAGNOSES — A/T Shift Lock System</b> .....117
<b>TROUBLE DIAGNOSES</b> .....15	Description.....117
How to Perform Trouble Diagnoses for Quick and Accurate Repair.....15	Shift Lock System Electrical Parts Location.....117
Remarks.....19	Wiring Diagram — SHIFT —.....118
Diagnostic Trouble Code (DTC) Chart.....20	Diagnostic Procedure.....119
Diagnosis by CONSULT.....22	Key Interlock Cable.....121
Preliminary Check.....25	Component Check.....122
A/T Electrical Parts Location.....37	<b>ON-VEHICLE SERVICE</b> .....124
Circuit Diagram for Quick Pinpoint Check.....38	Control Valve Assembly and Accumulator.....124
Wiring Diagram — AT —.....39	Revolution Sensor Replacement.....125
Self-diagnosis.....46	Inhibitor Switch Adjustment.....125
Diagnostic Procedure 1.....87	Control Cable Adjustment.....126
Diagnostic Procedure 2.....88	Differential Side Oil Seal Replacement.....126
Diagnostic Procedure 3.....88	<b>REMOVAL AND INSTALLATION</b> .....127
Diagnostic Procedure 4.....89	Removal.....127
Diagnostic Procedure 5.....90	Installation.....127
Diagnostic Procedure 6.....91	<b>MAJOR OVERHAUL</b> .....129
Diagnostic Procedure 7.....92	Oil Channel.....132
Diagnostic Procedure 8.....93	<b>DISASSEMBLY</b> .....133
Diagnostic Procedure 9.....94	<b>REPAIR FOR COMPONENT PARTS</b> .....147
Diagnostic Procedure 10.....95	Manual Shaft.....147
Diagnostic Procedure 11.....96	Oil Pump.....149
Diagnostic Procedure 12.....97	Control Valve Assembly.....153
Diagnostic Procedure 13.....98	Control Valve Upper Body.....161
Diagnostic Procedure 14.....98	Control Valve Lower Body.....165
	Reverse Clutch.....167

# CONTENTS (Cont'd)

High Clutch .....	170	<b>ASSEMBLY</b> .....	205
Forward Clutch and Overrun Clutch.....	174	Assembly 1 .....	205
Low & Reverse Brake.....	180	Adjustment 1 .....	205
Rear Internal Gear, Forward Clutch Hub and Overrun Clutch Hub.....	182	Assembly 2 .....	210
Output Shaft, Idler Gear, Reduction Pinion Gear and Bearing Retainer.....	186	Adjustment 2.....	216
Band Servo Piston Assembly .....	191	Assembly 3 .....	218
Final Drive — RE4F04A.....	196	<b>SERVICE DATA AND SPECIFICATIONS (SDS)</b> .....	224
Final Drive — RE4F04V .....	200	General Specifications.....	224
		Specifications and Adjustments.....	224

**When you read wiring diagrams:**

- Read GI section, "HOW TO READ WIRING DIAGRAMS".
- See EL section, "POWER SUPPLY ROUTING" for power distribution circuit.

**When you perform trouble diagnoses, read GI section, "HOW TO FOLLOW FLOW CHART IN TROUBLE DIAGNOSES" and "HOW TO PERFORM EFFICIENT DIAGNOSIS FOR AN ELECTRICAL INCIDENT".**

# PREPARATION AND PRECAUTIONS

## Special Service Tools

The actual shapes of Kent-Moore tools may differ from those of special service tools illustrated here.

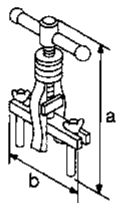
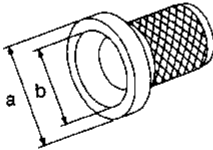
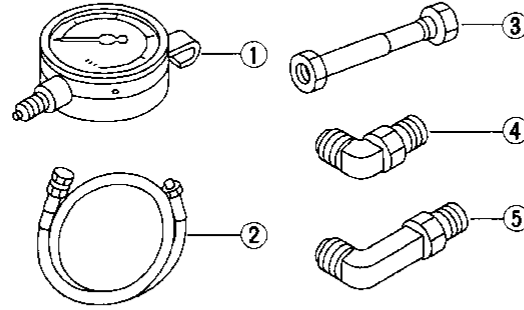
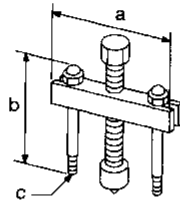
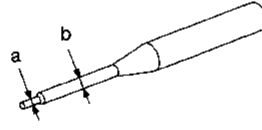
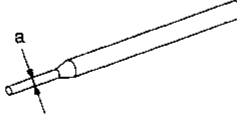
Tool number (Kent-Moore No.) Tool name	Description	
KV381054S0 (J34286) Puller	 <p>NT414</p>	<ul style="list-style-type: none"> <li>• Removing differential side oil seals</li> <li>• Removing differential side bearing outer race</li> <li>• Removing idler gear bearing outer race</li> </ul> <p><b>a: 250 mm (9.84 in)</b> <b>b: 160 mm (6.30 in)</b></p>
ST33400001 (J26082) Drift	 <p>NT086</p>	<p>Installing differential side oil seal (RH side) Installing oil seal on oil pump housing</p> <p><b>a: 60 mm (2.36 in) dia.</b> <b>b: 47 mm (1.85 in) dia.</b></p>
ST2505S001 (J34301-C) Oil pressure gauge set ① ST25051001 ( — ) Oil pressure gauge ② ST25052000 ( — ) Hose ③ ST25053000 ( — ) Joint pipe ④ ST25054000 ( — ) Adapter ⑤ ST25055000 ( — ) Adapter	 <p>NT097</p>	<p>Measuring line pressure.</p>
ST27180001 (J25726-A) Puller	 <p>NT424</p>	<p>Removing idler gear</p> <p><b>a: 100 mm (3.94 in)</b> <b>b: 110 mm (4.33 in)</b> <b>c: M8 x 1.25P</b></p>
ST23540000 (J25689-A) Pin punch	 <p>NT442</p>	<p>Removing and installing parking rod plate and manual plate pins.</p> <p><b>a: 2.3 mm (0.091 in) dia.</b> <b>b: 4 mm (0.16 in) dia.</b></p>
ST25710000 (J25689-A) Pin punch	 <p>NT410</p>	<p>Aligning groove of manual shaft and hole of transmission case.</p> <p><b>a: 2 mm (0.08 in) dia.</b></p>

## PREPARATION AND PRECAUTIONS

### Special Service Tools (Cont'd)

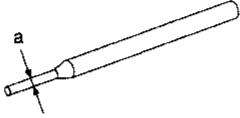
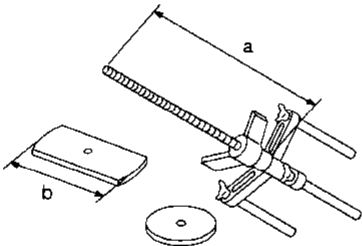
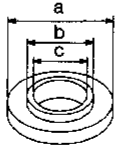
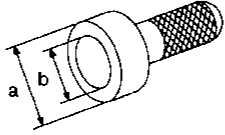
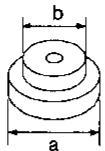
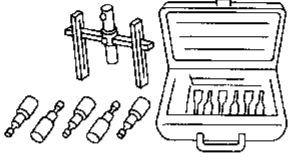
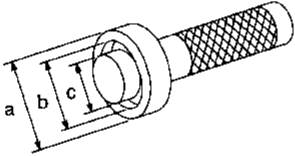
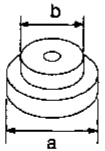
Tool number (Kent-Moore No.) Tool name	Description	
KV32101000 (J25689-A) Pin punch	 <p style="text-align: center;">NT410</p>	Installing manual shaft retaining pin  <b>a: 4 mm (0.16 in) dia.</b>
KV31102400 (J34285 and J34285-87) Clutch spring compressor	 <p style="text-align: center;">NT423</p>	<ul style="list-style-type: none"> <li>• Removing and installing clutch return springs</li> <li>• Installing low and reverse brake piston</li> </ul> <b>a: 320 mm (12.60 in)</b> <b>b: 174 mm (6.85 in)</b>
KV40100630 ( — ) Drift	 <p style="text-align: center;">NT107</p>	<ul style="list-style-type: none"> <li>• Installing reduction gear bearing inner race</li> <li>• Installing idler gear bearing inner race</li> </ul> <b>a: 67.5 mm (2.657 in) dia.</b> <b>b: 44 mm (1.73 in) dia.</b> <b>c: 38.5 mm (1.516 in) dia.</b>
ST30720000 (J34331)	 <p style="text-align: center;">NT115</p>	<ul style="list-style-type: none"> <li>• Installing idler gear bearing outer race</li> </ul> <b>a: 77 mm (3.03 in) dia.</b> <b>b: 55.5 mm (2.185 in) dia.</b>
ST35321000 ( — ) Drift	 <p style="text-align: center;">NT073</p>	<ul style="list-style-type: none"> <li>• Installing output shaft bearing</li> </ul> <b>a: 49 mm (1.93 in) dia.</b> <b>b: 41 mm (1.61 in) dia.</b>
(J34291) Shim setting gauge set	 <p style="text-align: center;">NT101</p>	<ul style="list-style-type: none"> <li>• Selecting oil pump cover bearing race and oil pump thrust washer</li> <li>• Selecting side gear thrust washer</li> </ul>
KV38100300 ( — )	 <p style="text-align: center;">NT085</p>	Installing differential side bearing inner race (RH side)  <b>a: 54 mm (2.13 in) dia.</b> <b>b: 46 mm (1.81 in) dia.</b> <b>c: 32 mm (1.26 in) dia.</b>
ST30613000 ( — )	 <p style="text-align: center;">NT073</p>	Installing differential side bearing inner race (LH side)  <b>a: 72 mm (2.83 in) dia.</b> <b>b: 48 mm (1.89 in) dia.</b>

# PREPARATION AND PRECAUTIONS

## Special Service Tools (Cont'd)

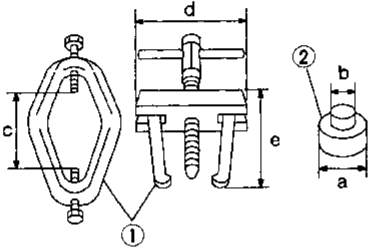
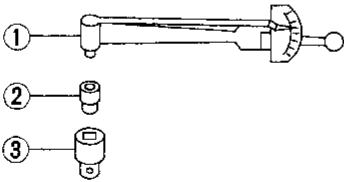
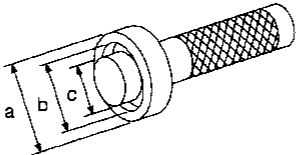
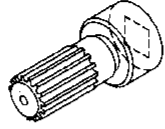
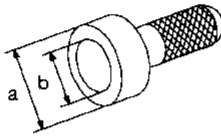
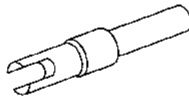
Tool number (Kent-Moore No.) Tool name	Description	
ST3306S001 (J22888-D) Differential side bearing puller set ① ST33051001 ( — ) Puller ② ST33061000 (J8107-2) Adapter		Removing differential side bearing inner race  a: 38 mm (1.50 in) dia. b: 28.5 mm (1.122 in) dia. c: 130 mm (5.12 in) d: 135 mm (5.31 in) e: 100 mm (3.94 in)
ST3127S000 (See J25765-A) Preload gauge ① GG91030000 (J25765-A) Torque wrench ② HT62940000 ( — ) Socket adapter ③ HT62900000 ( — ) Socket adapter		Checking differential side bearing preload
ST33220000 ( — ) Drift		Selecting differential side bearing adjusting shim (F04V)  a: 37 mm (1.46 in) dia. b: 31 mm (1.22 in) dia. c: 22 mm (0.87 in) dia.
KV38105210 ( — ) Preload adapter		<ul style="list-style-type: none"> <li>• Selecting differential side bearing adjusting shim (F04V)</li> <li>• Checking differential side bearing preload (F04V)</li> </ul>
ST35271000 ( — ) Drift		Installing idler gear  a: 72 mm (2.83 in) dia. b: 63 mm (2.48 in) dia.
KV38107700 (J39027) Preload adapter		<ul style="list-style-type: none"> <li>• Selecting differential side bearing adjusting shim (F04A)</li> <li>• Checking differential side bearing preload (F04A)</li> </ul>

GI  
 MA  
 EM  
 LC  
 EC  
 FE  
 CL  
 MT  
**AT**  
 FA  
 RA  
 BR  
 ST  
 RS  
 BT  
 HA  
 EL  
 IDX

## PREPARATION AND PRECAUTIONS

### Special Service Tools (Cont'd)

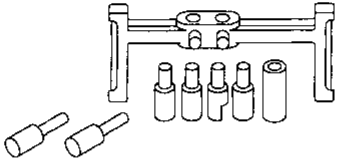
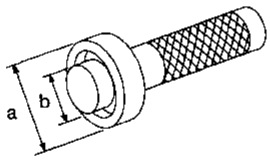
Tool number (Kent-Moore No.) Tool name	Description	
(J34290) Shim selecting tool set	 <p style="text-align: center;">NT080</p>	Selecting differential side bearing adjusting shim
ST33230000 ( ) Drift	 <p style="text-align: center;">NT084</p>	Installing differential side bearing  <b>a: 51 mm (2.01 in) dia.</b> <b>b: 28.5 mm (1.122 in) dia.</b>

### Commercial Service Tools

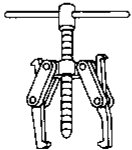
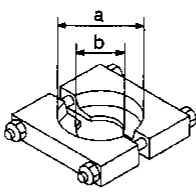
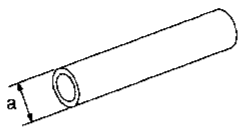
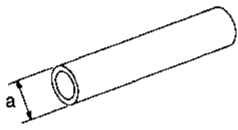
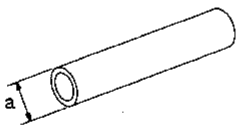
Tool name	Description	
Puller	 <p style="text-align: center;">NT077</p> <ul style="list-style-type: none"> <li>• Removing idler gear bearing inner race</li> <li>• Removing and installing band servo piston snap ring</li> </ul>	
Puller	 <p style="text-align: center;">NT411</p>	Removing reduction gear bearing inner race  <b>a: 60 mm (2.36 in) dia.</b> <b>b: 35 mm (1.38 in) dia.</b>
Drift	 <p style="text-align: center;">NT083</p>	Installing differential side oil seal (Left side)  <b>a: 90 mm (3.54 in) dia.</b>
Drift	 <p style="text-align: center;">NT083</p>	Installing needle bearing on bearing retainer  <b>a: 36 mm (1.42 in) dia.</b>
Drift	 <p style="text-align: center;">NT083</p>	Removing needle bearing from bearing retainer  <b>a: 33.5 mm (1.319 in) dia.</b>

## Service Notice

- Before proceeding with disassembly, thoroughly clean the outside of the transaxle. It is important to prevent the internal parts from becoming contaminated by dirt or other foreign matter.
- Disassembly should be done in a clean work area.
- Use lint-free cloth or towels for wiping parts clean. Common shop rags can leave fibers that could interfere with the operation of the transaxle.
- Place disassembled parts in order for easier and proper assembly.
- All parts should be carefully cleaned with a general purpose, non-flammable solvent before inspection or reassembly.
- Gaskets, seals and O-rings should be replaced any time the transaxle is disassembled.
- When connecting A/T control unit harness connector, tighten bolt until red projection is in line with connector.

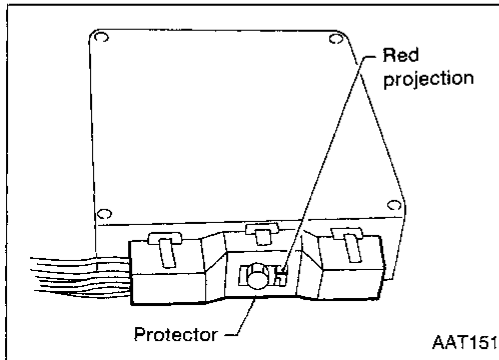

- It is very important to perform functional tests whenever they are indicated.

- The valve body contains precision parts and requires extreme care when parts are removed and serviced. Place removed parts in a parts rack in order to replace them in correct positions and sequences. Care will also prevent springs and small parts from becoming scattered or lost.
- Properly installed valves, sleeves, plugs, etc. will slide along bores in valve body under their own weight.
- Before assembly, apply a coat of recommended ATF to all parts. Apply petroleum jelly to protect O-rings and seals, and to hold bearings and washers in place during assembly. Do not use grease.
- Extreme care should be taken to avoid damage to O-rings, seals and gaskets when assembling.
- Flash or replace ATF cooler if excessive foreign material is found in oil pan or clogging strainer. Refer to TROUBLE DIAGNOSES Remarks, AT-19.
- After overhaul, refill the transaxle with new ATF.
- When the A/T drain plug is removed, only some of the fluid is drained. Old A/T fluid will remain in torque converter and ATF cooling system. Always follow the procedures under "Changing A/T Fluid" in the MA section when changing A/T fluid.

GI

MA

EM

LC

EC

FE

CL

MT

AT

FA

RA

BR

ST

RS

BT

HA

EL

IDX

### **Supplemental Restraint System (SRS) "AIR BAG"**

The Supplemental Restraint System "Air Bag", used along with a seat belt, helps to reduce the risk or severity of injury to the driver and front passenger in a frontal collision. The Supplemental Restraint System consists of air bag modules (located in the center of the steering wheel and on the instrument panel on the passenger side), a diagnosis sensor unit, warning lamp, wiring harness and spiral cable. Information necessary to service the system safely is included in the **RS section** of this Service Manual.

**WARNING:**

- **To avoid rendering the SRS inoperative, which could increase the risk of personal injury or death in the event of a collision which would result in air bag inflation, all maintenance must be performed by an authorized NISSAN dealer.**
- **Improper maintenance, including incorrect removal and installation of the SRS, can lead to personal injury caused by unintentional activation of the system.**
- **Do not use electrical test equipment on any circuit related to the SRS unless instructed to in this Service Manual. SRS wiring harnesses are covered with yellow insulation either just before the harness connectors or for the complete harness, for easy identification.**



# DESCRIPTION

## Cross-sectional View

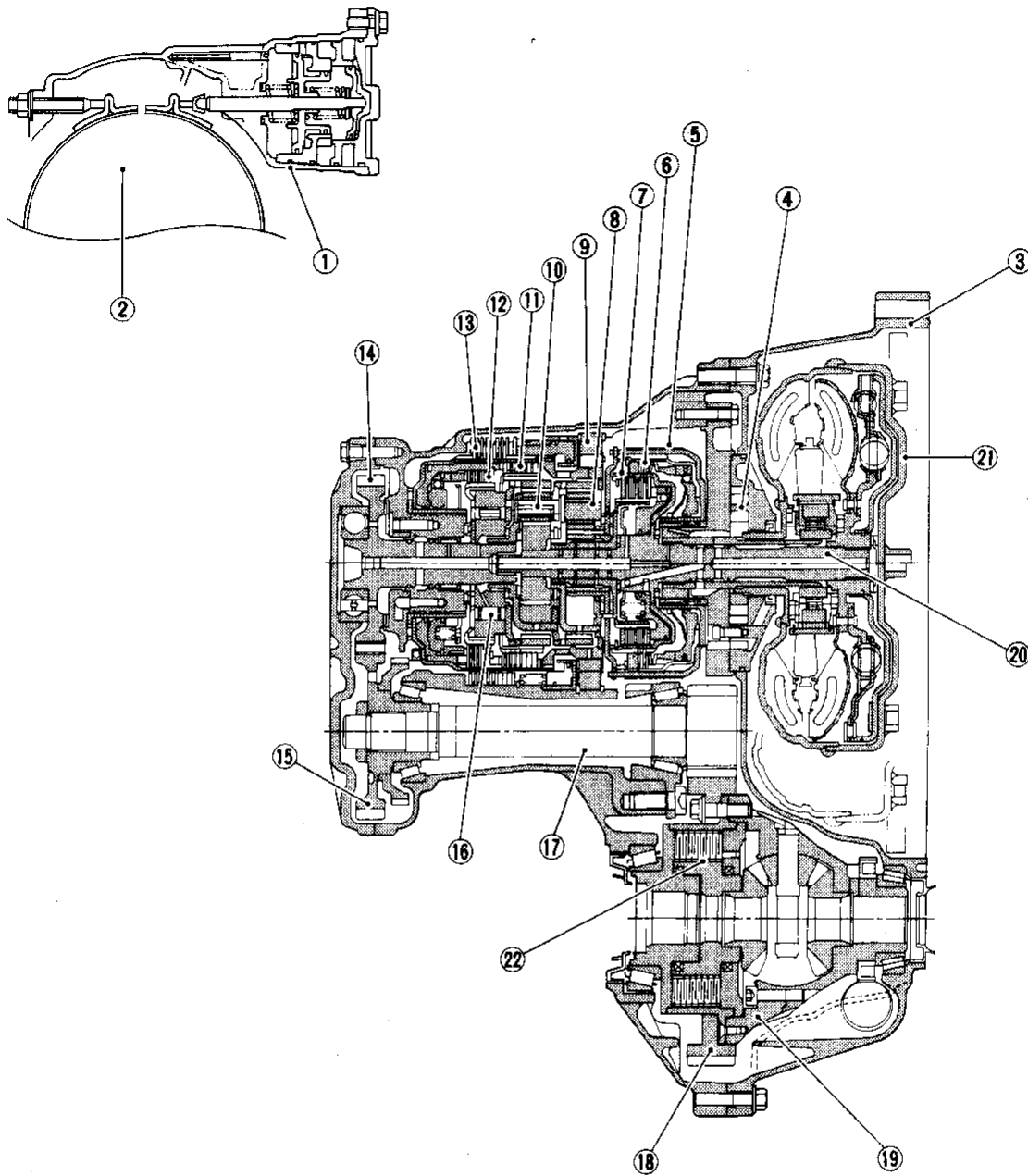

- |                       |                        |                          |
|-----------------------|------------------------|--------------------------|
| ① Band servo piston   | ⑧ Front planetary gear | ⑮ Idler gear             |
| ② Reverse clutch drum | ⑨ Low one-way clutch   | ⑯ Forward one-way clutch |
| ③ Converter housing   | ⑩ Rear planetary gear  | ⑰ Pinion reduction gear  |
| ④ Oil pump            | ⑪ Forward clutch       | ⑱ Final gear             |
| ⑤ Brake band          | ⑫ Overrun clutch       | ⑲ Differential case      |
| ⑥ Reverse clutch      | ⑬ Low & reverse brake  | ⑳ Input shaft            |
| ⑦ High clutch         | ⑭ Output gear          | ㉑ Torque converter       |
|                       |                        | ㉒ Viscous coupling       |

SAT901H

GI

MA

EM

LC

EC

FE

CL

MT

AT

FA

RA

BR

ST

RS

BT

HA

EL

IDX

DESCRIPTION

Hydraulic Control Circuit

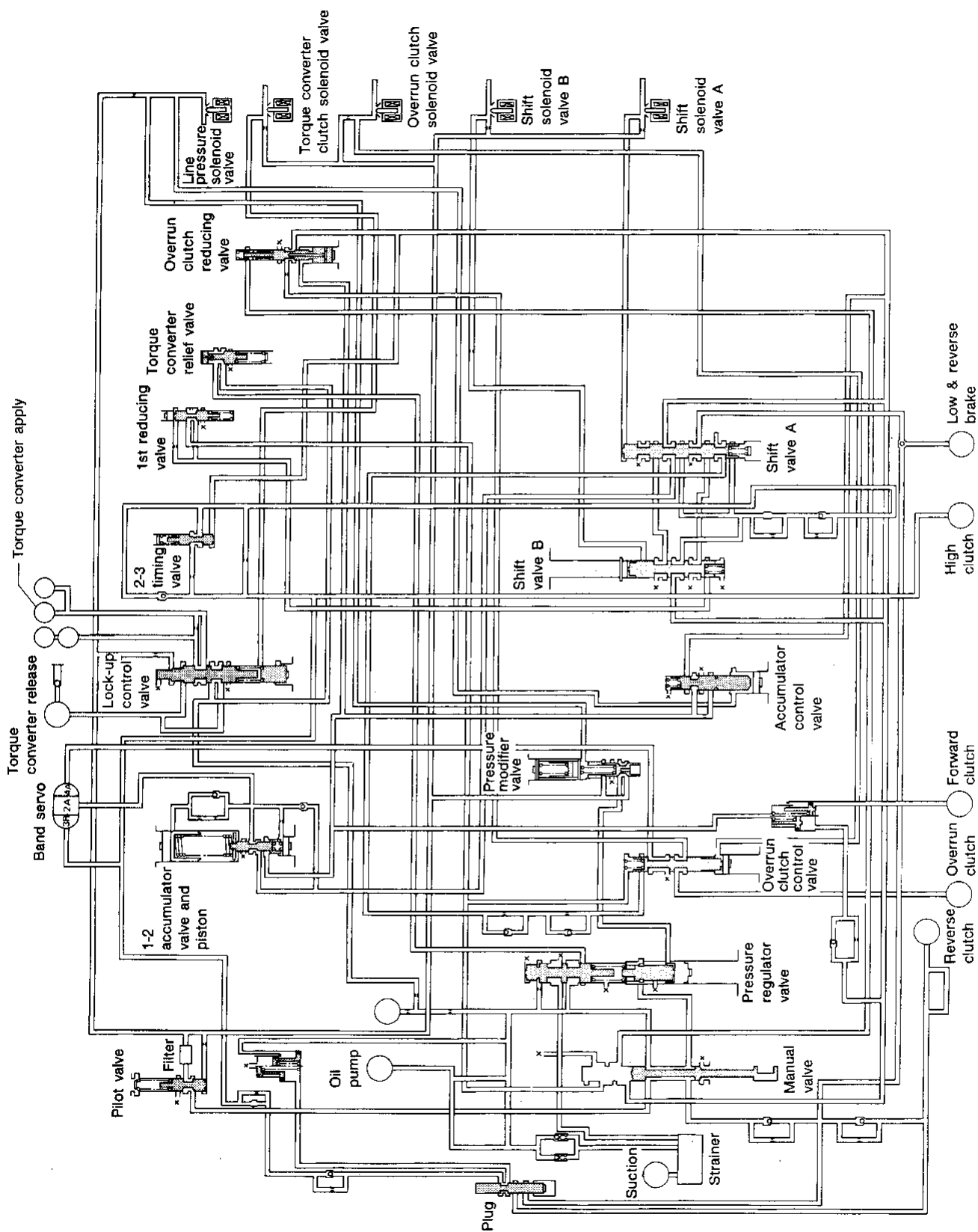

# DESCRIPTION

## Shift Mechanism CONSTRUCTION

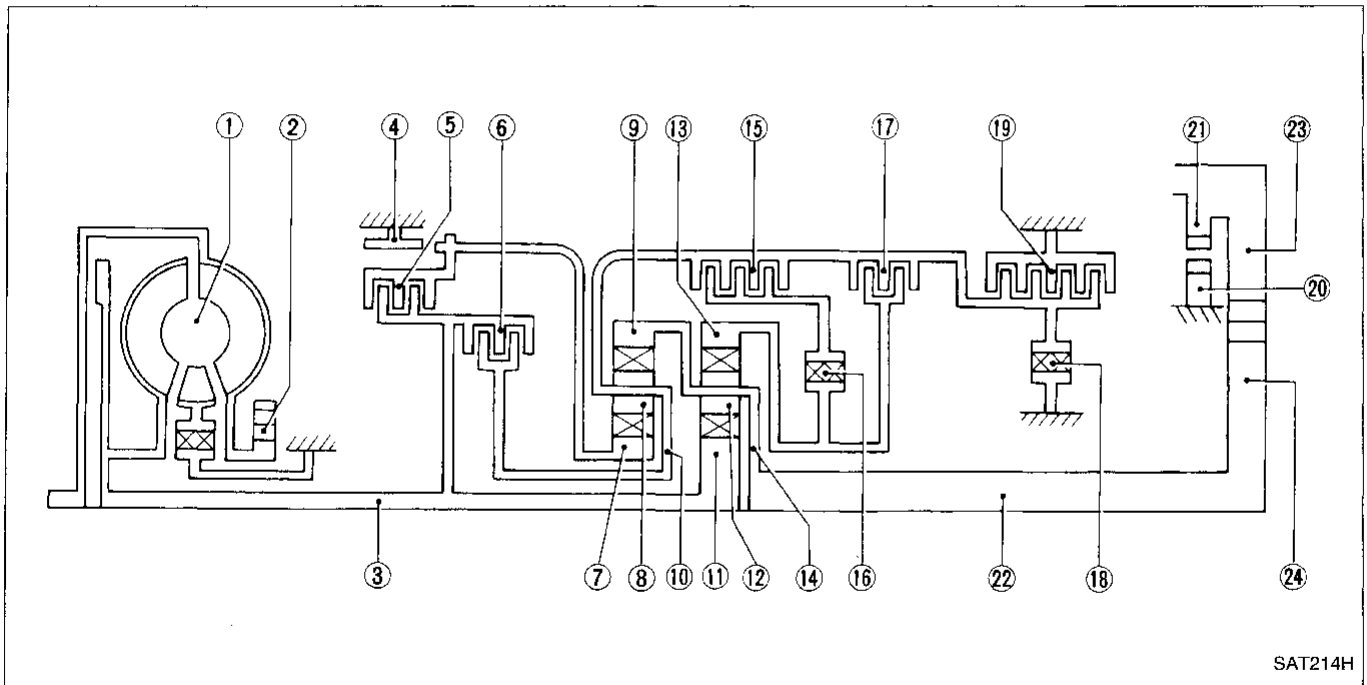

- |                     |                           |                       |
|---------------------|---------------------------|-----------------------|
| ① Torque converter  | ⑨ Front internal gear     | ⑰ Overrun clutch      |
| ② Oil pump          | ⑩ Front planetary carrier | ⑱ Low one-way clutch  |
| ③ Input shaft       | ⑪ Rear sun gear           | ⑲ Low & reverse brake |
| ④ Brake band        | ⑫ Rear pinion gear        | ⑳ Parking pawl        |
| ⑤ Reverse clutch    | ⑬ Rear internal gear      | ㉑ Parking gear        |
| ⑥ High clutch       | ⑭ Rear planetary carrier  | ㉒ Output shaft        |
| ⑦ Front sun gear    | ⑮ Forward clutch          | ㉓ Idle gear           |
| ⑧ Front pinion gear | ⑯ Forward one-way clutch  | ㉔ Output gear         |

### FUNCTION OF CLUTCH AND BRAKE

Clutch and brake components	Abbr.	Function
⑤ Reverse clutch	R/C	To transmit input power to front sun gear ⑦ .
⑥ High clutch	H/C	To transmit input power to front planetary carrier ⑩ .
⑮ Forward clutch	F/C	To connect front planetary carrier ⑩ with forward one-way clutch ⑯ .
⑰ Overrun clutch	O/C	To connect front planetary carrier ⑩ with rear internal gear ⑬ .
④ Brake band	B/B	To lock front sun gear ⑦ .
⑯ Forward one-way clutch	F/O.C	When forward clutch ⑮ is engaged, to stop rear internal gear ⑬ from rotating in opposite direction against engine revolution.
⑱ Low one-way clutch	L/O.C	To stop front planetary carrier ⑩ from rotating in opposite direction against engine revolution.
⑲ Low & reverse brake	L & R/B	To lock front planetary carrier ⑩ .

# DESCRIPTION

## Shift Mechanism (Cont'd)

### OPERATION OF CLUTCH AND BRAKE

Shift position	Reverse clutch	High clutch	Forward clutch	Overrun clutch	Band servo			Forward one-way clutch	Low one-way clutch	Low & reverse brake	Lock-up	Remarks
					2nd apply	3rd release	4th apply					
P												PARK POSITION
R	○									○		REVERSE POSITION
N												NEUTRAL POSITION
D*4	1st		○	*1●				●	●			Automatic shift 1 ↔ 2 ↔ 3 ↔ 4
	2nd		○	*1○	○			●				
	3rd		○	*1○	*2⊗	⊗		●			○	
	4th		○	⊗		*3⊗	⊗	○			○	
2	1st		○	○				●	●			Automatic shift 1 ↔ 2 ↔ 3
	2nd		○	○	○			●				
1	1st		○	○				●	●	○		Locks (held stationary) in 1st speed 1 ↔ 2 ↔ 3
	2nd		○	○	○			●				

\*1: Operates when overdrive switch is being set in "OFF" position.

\*2: Oil pressure is applied to both 2nd "apply" side and 3rd "release" side of band servo piston. However, brake band does not contract because oil pressure area on the "release" side is greater than that on the "apply" side.

\*3: Oil pressure is applied to 4th "apply" side in condition \*2 above, and brake band contracts.

\*4: A/T will not shift to 4th when overdrive switch is set in "OFF" position.

○ : Operates.

○ : Operates when throttle opening is less than 1/16, activating engine brake.

● : Operates during "progressive" acceleration.

⊗ : Operates but does not affect power transmission.

● : Operates when throttle opening is less than 1/16, but does not affect engine brake.

# DESCRIPTION

## Control System

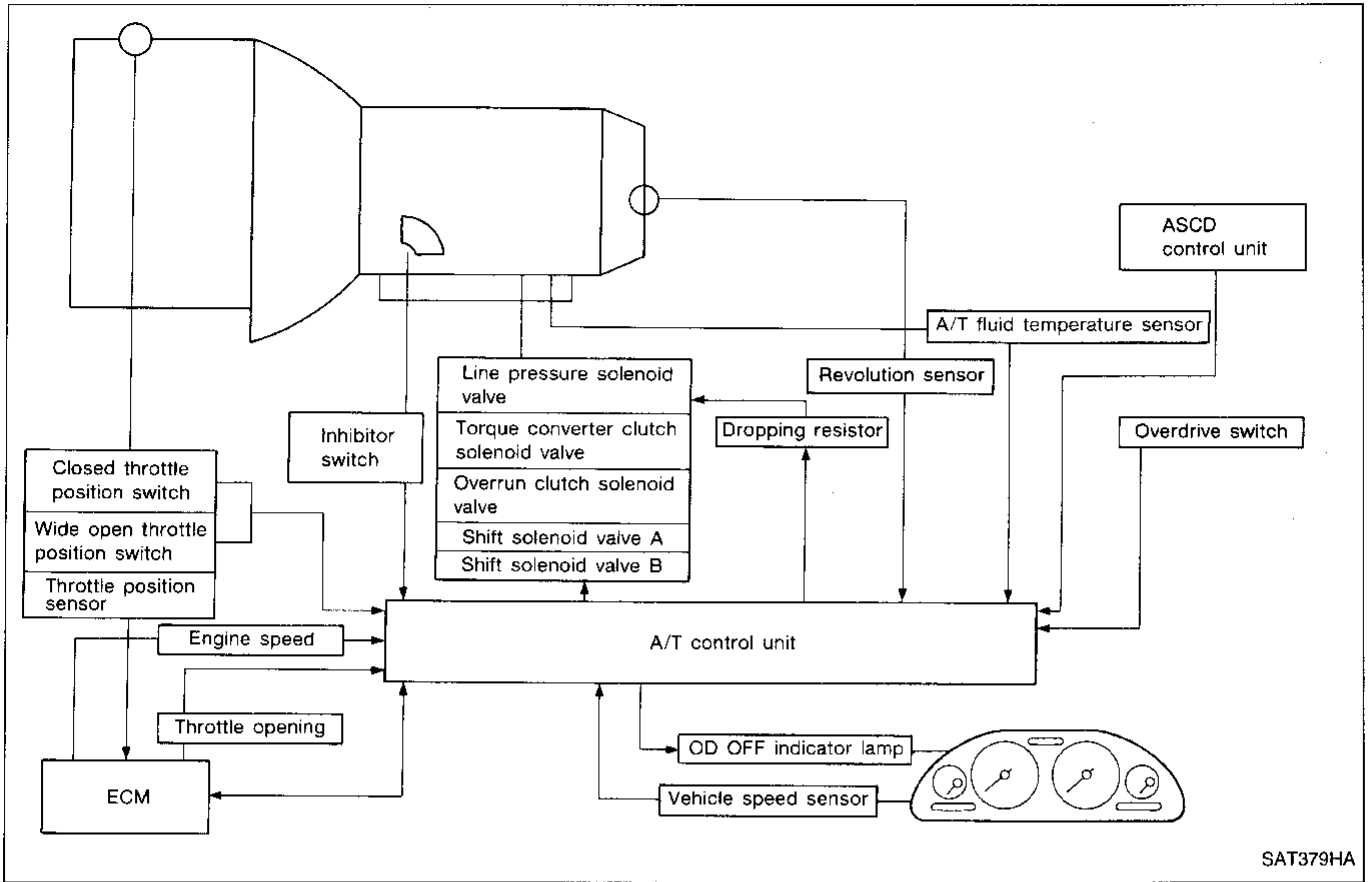

GI  
MA  
EM  
LC  
EC  
FE  
CL  
MT  
AT  
FA  
RA  
BR  
ST  
RS  
BT  
HA  
EL  
DX

## DESCRIPTION

### Control System (Cont'd)

#### A/T CONTROL UNIT FUNCTION

The A/T control unit receives signals sent from various switches and sensors. The control unit then determines required line pressure, shifting point, lock-up operation, engine brake operation. The unit sends required signals to the respective solenoids.

#### INPUT/OUTPUT SIGNAL OF A/T CONTROL UNIT

	Sensors and solenoid valves	Function
Input	Inhibitor switch	Detects select lever position and sends a signal to A/T control unit.
	Throttle position sensor	Detects throttle valve position and sends a signal to A/T control unit.
	Closed throttle position switch	Detects throttle valve's fully-closed position and sends a signal to A/T control unit.
	Wide open throttle position switch	Detects a throttle valve position of greater than 1/2 of full throttle and sends a signal to A/T control unit.
	Engine speed signal	From ECM (ECCS control module).
	A/T fluid temperature sensor	Detects transmission fluid temperature and sends a signal to A/T control unit.
	Revolution sensor	Detects output shaft rpm and sends a signal to A/T control unit.
	Vehicle speed sensor	Used as an auxiliary vehicle speed sensor. Sends a signal when revolution sensor (installed on transmission) malfunctions.
	OD OFF switch	Sends a signal, which prohibits a shift to D <sub>4</sub> (OD) position, to the A/T control unit.
	Output	Shift solenoid valve A/B
Line pressure solenoid valve		Regulates (or decreases) line pressure suited to driving conditions in relation to a signal sent from A/T control unit.
Torque converter clutch solenoid valve		Regulates (or decreases) lock-up pressure suited to driving conditions in relation to a signal sent from A/T control unit.
Overrun clutch solenoid valve		Controls an "engine brake" effect suited to driving conditions in relation to a signal sent from A/T control unit.

# TROUBLE DIAGNOSES

## How to Perform Trouble Diagnoses for Quick and Accurate Repair

A good understanding of the malfunction conditions can make troubleshooting faster and more accurate. In general, each customer feels differently about a problem. It is important to fully understand the symptoms or conditions for a customer complaint.

Make good use of the two sheets provided, "INFORMATION FROM CUSTOMER" and "DIAGNOSTIC WORKSHEET", to perform the best troubleshooting possible.

### WORK FLOW

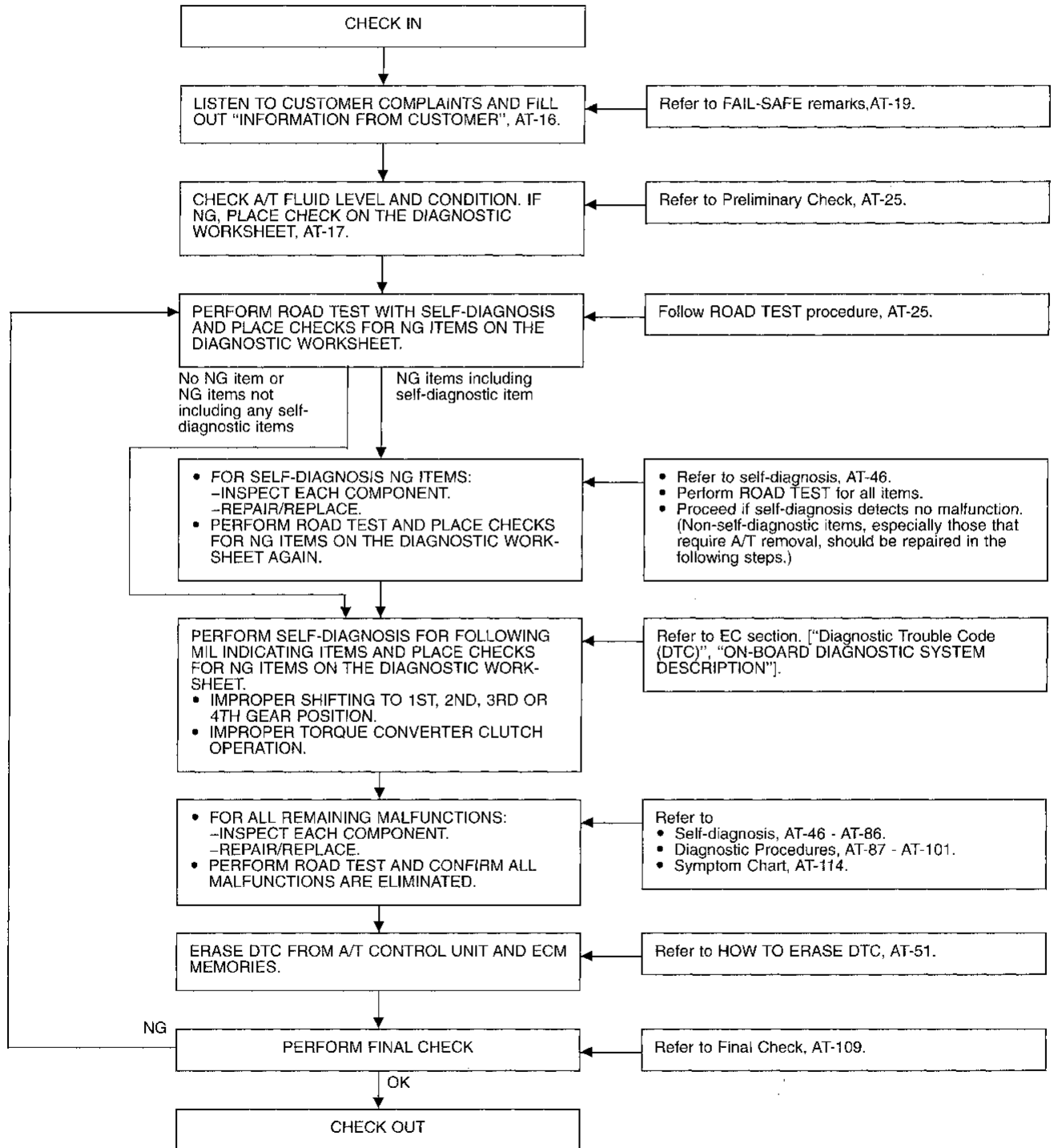

# TROUBLE DIAGNOSES

## How to Perform Trouble Diagnoses for Quick and Accurate Repair (Cont'd)

### INFORMATION FROM CUSTOMER

#### KEY POINTS

**WHAT** ..... Vehicle & A/T model

**WHEN** ..... Date, Frequencies

**WHERE** ..... Road conditions

**HOW** ..... Operating conditions, Symptoms

Customer name MR/MS	Model & Year	VIN
Trans. model	Engine	Mileage
Incident Date	Manuf. Date	In Service Date
Frequency	<input type="checkbox"/> Continuous <input type="checkbox"/> Intermittent ( times a day)	
Symptoms	<input type="checkbox"/> Vehicle does not move. ( <input type="checkbox"/> Any position <input type="checkbox"/> Particular position)	
	<input type="checkbox"/> No up-shift ( <input type="checkbox"/> 1st → 2nd <input type="checkbox"/> 2nd → 3rd <input type="checkbox"/> 3rd → O/D)	
	<input type="checkbox"/> No down-shift ( <input type="checkbox"/> O/D → 3rd <input type="checkbox"/> 3rd → 2nd <input type="checkbox"/> 2nd → 1st)	
	<input type="checkbox"/> Lockup malfunction	
	<input type="checkbox"/> Shift point too high or too low.	
	<input type="checkbox"/> Shift shock or slip ( <input type="checkbox"/> N → D <input type="checkbox"/> Lockup <input type="checkbox"/> Any drive position)	
	<input type="checkbox"/> Noise or vibration	
	<input type="checkbox"/> No kickdown	
	<input type="checkbox"/> No pattern select	
	<input type="checkbox"/> Others ( )	
OD OFF indicator lamp	Blinks for about 8 seconds.	
	<input type="checkbox"/> Continuously lit	<input type="checkbox"/> Not lit
Malfunction indicator lamp (MIL)	<input type="checkbox"/> Continuously lit	<input type="checkbox"/> Not lit



# TROUBLE DIAGNOSES

## How to Perform Trouble Diagnoses for Quick and Accurate Repair (Cont'd)

### DIAGNOSTIC WORKSHEET

1.	<input type="checkbox"/> Read the Fail-safe Remarks and listen to customer complaints.	AT-19		
2.	<input type="checkbox"/> CHECK A/T FLUID <input type="checkbox"/> Leakage (Follow specified procedure) <input type="checkbox"/> Fluid condition <input type="checkbox"/> Fluid level	AT-25		
3.	<input type="checkbox"/> Perform all ROAD TESTING and mark required procedures.	AT-25		
	3-1 Check before engine is started. <input type="checkbox"/> SELF-DIAGNOSTIC PROCEDURE — Mark detected items. <table style="width: 100%; border: none;"> <tr> <td style="width: 50%; vertical-align: top;"> <b>A/T control unit-diagnosis system</b>  <input type="checkbox"/> Revolution sensor  <input type="checkbox"/> Vehicle speed sensor  <input type="checkbox"/> Throttle position sensor  <input type="checkbox"/> Shift solenoid valve A  <input type="checkbox"/> Shift solenoid valve B  <input type="checkbox"/> Overrun clutch solenoid valve  <input type="checkbox"/> Torque converter clutch solenoid valve  <input type="checkbox"/> A/T fluid temperature sensor and A/T control unit power source  <input type="checkbox"/> Engine speed signal  <input type="checkbox"/> Line pressure solenoid valve  <input type="checkbox"/> Battery  <input type="checkbox"/> Others             </td> <td style="width: 50%; vertical-align: top;"> <b>ECM-A/T diagnosis system</b>  <input type="checkbox"/> Inhibitor switch circuit  <input type="checkbox"/> Improper shifting to 1st gear position  <input type="checkbox"/> Improper shifting to 2nd gear position  <input type="checkbox"/> Improper shifting to 3rd gear position  <input type="checkbox"/> Improper shifting to 4th gear position or TCC             </td> </tr> </table>	<b>A/T control unit-diagnosis system</b> <input type="checkbox"/> Revolution sensor <input type="checkbox"/> Vehicle speed sensor <input type="checkbox"/> Throttle position sensor <input type="checkbox"/> Shift solenoid valve A <input type="checkbox"/> Shift solenoid valve B <input type="checkbox"/> Overrun clutch solenoid valve <input type="checkbox"/> Torque converter clutch solenoid valve <input type="checkbox"/> A/T fluid temperature sensor and A/T control unit power source <input type="checkbox"/> Engine speed signal <input type="checkbox"/> Line pressure solenoid valve <input type="checkbox"/> Battery <input type="checkbox"/> Others	<b>ECM-A/T diagnosis system</b> <input type="checkbox"/> Inhibitor switch circuit <input type="checkbox"/> Improper shifting to 1st gear position <input type="checkbox"/> Improper shifting to 2nd gear position <input type="checkbox"/> Improper shifting to 3rd gear position <input type="checkbox"/> Improper shifting to 4th gear position or TCC	AT-26
<b>A/T control unit-diagnosis system</b> <input type="checkbox"/> Revolution sensor <input type="checkbox"/> Vehicle speed sensor <input type="checkbox"/> Throttle position sensor <input type="checkbox"/> Shift solenoid valve A <input type="checkbox"/> Shift solenoid valve B <input type="checkbox"/> Overrun clutch solenoid valve <input type="checkbox"/> Torque converter clutch solenoid valve <input type="checkbox"/> A/T fluid temperature sensor and A/T control unit power source <input type="checkbox"/> Engine speed signal <input type="checkbox"/> Line pressure solenoid valve <input type="checkbox"/> Battery <input type="checkbox"/> Others	<b>ECM-A/T diagnosis system</b> <input type="checkbox"/> Inhibitor switch circuit <input type="checkbox"/> Improper shifting to 1st gear position <input type="checkbox"/> Improper shifting to 2nd gear position <input type="checkbox"/> Improper shifting to 3rd gear position <input type="checkbox"/> Improper shifting to 4th gear position or TCC			
	3-2. Check at idle <input type="checkbox"/> Diagnostic Procedure 1 (OD OFF indicator lamp came on for 2 seconds.) <input type="checkbox"/> Diagnostic Procedure 2 (Engine starts only in P and N position) <input type="checkbox"/> Diagnostic Procedure 3 (In P position, vehicle does not move when pushed) <input type="checkbox"/> Diagnostic Procedure 4 (In N position, vehicle moves) <input type="checkbox"/> Diagnostic Procedure 5 (Select shock. N → R position) <input type="checkbox"/> Diagnostic Procedure 6 (Vehicle creeps backward in R position) <input type="checkbox"/> Diagnostic Procedure 7 (Vehicle creeps forward in D, 2 or 1 position)	AT-27		
	3-3. Cruise test <b>Part-1</b> <input type="checkbox"/> Diagnostic Procedure 8 (Vehicle starts from D <sub>1</sub> ) <input type="checkbox"/> Diagnostic Procedure 9 <input type="checkbox"/> Diagnostic Procedure 10 <input type="checkbox"/> Diagnostic Procedure 11 <table style="display: inline-table; vertical-align: middle;"> <tr> <td style="font-size: 2em; vertical-align: middle;">}</td> <td style="vertical-align: middle;">(A/T shift schedule: D<sub>1</sub> → D<sub>2</sub>/D<sub>2</sub> → D<sub>3</sub>/D<sub>3</sub> → D<sub>4</sub>/D<sub>4</sub> → D<sub>2</sub>)</td> </tr> </table> <input type="checkbox"/> Diagnostic Procedure 12 (Shift schedule: Lock-up) <input type="checkbox"/> Diagnostic Procedure 13 (Lock-up condition more than 30 seconds) <input type="checkbox"/> Diagnostic Procedure 14 (Lock up released) <input type="checkbox"/> Diagnostic Procedure 15 (Engine speed return to idle. Light braking D <sub>4</sub> → D <sub>3</sub> )	}	(A/T shift schedule: D <sub>1</sub> → D <sub>2</sub> /D <sub>2</sub> → D <sub>3</sub> /D <sub>3</sub> → D <sub>4</sub> /D <sub>4</sub> → D <sub>2</sub> )	AT-29
}	(A/T shift schedule: D <sub>1</sub> → D <sub>2</sub> /D <sub>2</sub> → D <sub>3</sub> /D <sub>3</sub> → D <sub>4</sub> /D <sub>4</sub> → D <sub>2</sub> )			

GI  
 MA  
 EM  
 LC  
 EC  
 FE  
 CL  
 MT  
**AT**  
 FA  
 RA  
 BR  
 ST  
 RS  
 BT  
 HA  
 EL  
 IDX

## TROUBLE DIAGNOSES

### How to Perform Trouble Diagnoses for Quick and Accurate Repair (Cont'd)

3.	<p><b>Part-2</b></p> <ul style="list-style-type: none"> <li><input type="checkbox"/> Diagnostic Procedure 8 (Vehicle starts from D<sub>1</sub>)</li> <li><input type="checkbox"/> Diagnostic Procedure 9 (Kickdown: D<sub>4</sub> → D<sub>2</sub>)</li> <li><input type="checkbox"/> Diagnostic Procedure 10 (Shift schedule: D<sub>2</sub> → D<sub>3</sub>)</li> <li><input type="checkbox"/> Diagnostic Procedure 11 (Shift schedule: D<sub>3</sub> → D<sub>4</sub> and engine brake)</li> </ul> <p><b>Part-3</b></p> <ul style="list-style-type: none"> <li><input type="checkbox"/> Diagnostic Procedure 17 (D<sub>4</sub> → D<sub>3</sub> when OD OFF switch ON → OFF)</li> <li><input type="checkbox"/> Diagnostic Procedure 15 (Engine brake in D<sub>3</sub>)</li> <li><input type="checkbox"/> Diagnostic Procedure 18 (D<sub>3</sub> → 2<sub>2</sub> when selector lever D → 2 position)</li> <li><input type="checkbox"/> Diagnostic Procedure 16 (Engine brake in 2<sub>2</sub>)</li> <li><input type="checkbox"/> Diagnostic Procedure 19 (2<sub>2</sub> → 1<sub>1</sub>, when selector lever 2 → 1 position)</li> <li><input type="checkbox"/> Diagnostic Procedure 20 (Engine brake in 1<sub>1</sub>)</li> <li><input type="checkbox"/> SELF-DIAGNOSTIC PROCEDURE — Mark detected items.</li> </ul> <table style="width: 100%; border: none;"> <tr> <td style="width: 50%; vertical-align: top;"> <p><b>A/T control unit-diagnosis system</b></p> <ul style="list-style-type: none"> <li><input type="checkbox"/> Revolution sensor</li> <li><input type="checkbox"/> Vehicle speed sensor</li> <li><input type="checkbox"/> Throttle position sensor</li> <li><input type="checkbox"/> Shift solenoid valve A</li> <li><input type="checkbox"/> Shift solenoid valve B</li> <li><input type="checkbox"/> Overrun clutch solenoid valve</li> <li><input type="checkbox"/> Torque converter clutch solenoid valve</li> <li><input type="checkbox"/> A/T fluid temperature sensor and A/T control unit power source</li> <li><input type="checkbox"/> Engine speed signal</li> <li><input type="checkbox"/> Line pressure solenoid valve</li> <li><input type="checkbox"/> Battery</li> <li><input type="checkbox"/> Others</li> </ul> </td> <td style="width: 50%; vertical-align: top;"> <p><b>ECM-A/T diagnosis system</b></p> <ul style="list-style-type: none"> <li><input type="checkbox"/> Inhibitor switch circuit</li> <li><input type="checkbox"/> Improper shifting to 1st gear position</li> <li><input type="checkbox"/> Improper shifting to 2nd gear position</li> <li><input type="checkbox"/> Improper shifting to 3rd gear position</li> <li><input type="checkbox"/> Improper shifting to 4th gear position or TCC</li> </ul> </td> </tr> </table>	<p><b>A/T control unit-diagnosis system</b></p> <ul style="list-style-type: none"> <li><input type="checkbox"/> Revolution sensor</li> <li><input type="checkbox"/> Vehicle speed sensor</li> <li><input type="checkbox"/> Throttle position sensor</li> <li><input type="checkbox"/> Shift solenoid valve A</li> <li><input type="checkbox"/> Shift solenoid valve B</li> <li><input type="checkbox"/> Overrun clutch solenoid valve</li> <li><input type="checkbox"/> Torque converter clutch solenoid valve</li> <li><input type="checkbox"/> A/T fluid temperature sensor and A/T control unit power source</li> <li><input type="checkbox"/> Engine speed signal</li> <li><input type="checkbox"/> Line pressure solenoid valve</li> <li><input type="checkbox"/> Battery</li> <li><input type="checkbox"/> Others</li> </ul>	<p><b>ECM-A/T diagnosis system</b></p> <ul style="list-style-type: none"> <li><input type="checkbox"/> Inhibitor switch circuit</li> <li><input type="checkbox"/> Improper shifting to 1st gear position</li> <li><input type="checkbox"/> Improper shifting to 2nd gear position</li> <li><input type="checkbox"/> Improper shifting to 3rd gear position</li> <li><input type="checkbox"/> Improper shifting to 4th gear position or TCC</li> </ul>	AT-34
<p><b>A/T control unit-diagnosis system</b></p> <ul style="list-style-type: none"> <li><input type="checkbox"/> Revolution sensor</li> <li><input type="checkbox"/> Vehicle speed sensor</li> <li><input type="checkbox"/> Throttle position sensor</li> <li><input type="checkbox"/> Shift solenoid valve A</li> <li><input type="checkbox"/> Shift solenoid valve B</li> <li><input type="checkbox"/> Overrun clutch solenoid valve</li> <li><input type="checkbox"/> Torque converter clutch solenoid valve</li> <li><input type="checkbox"/> A/T fluid temperature sensor and A/T control unit power source</li> <li><input type="checkbox"/> Engine speed signal</li> <li><input type="checkbox"/> Line pressure solenoid valve</li> <li><input type="checkbox"/> Battery</li> <li><input type="checkbox"/> Others</li> </ul>	<p><b>ECM-A/T diagnosis system</b></p> <ul style="list-style-type: none"> <li><input type="checkbox"/> Inhibitor switch circuit</li> <li><input type="checkbox"/> Improper shifting to 1st gear position</li> <li><input type="checkbox"/> Improper shifting to 2nd gear position</li> <li><input type="checkbox"/> Improper shifting to 3rd gear position</li> <li><input type="checkbox"/> Improper shifting to 4th gear position or TCC</li> </ul>			
	<ul style="list-style-type: none"> <li><input type="checkbox"/> For self-diagnosis NG items, inspect each component. Repair or replace the damaged parts.</li> </ul>	AT-22		
	<ul style="list-style-type: none"> <li><input type="checkbox"/> Perform all ROAD TESTING and re-mark required procedures.</li> </ul>	AT-26		
	<ul style="list-style-type: none"> <li><input type="checkbox"/> Perform SELF-DIAGNOSIS for following MIL indicating items and check out NG items. Refer to EC section ["Diagnostic Trouble Code (DTC)", "ON-BOARD DIAGNOSTIC SYSTEM DESCRIPTION"].</li> <li><input type="checkbox"/> DTC (1103, P0731) Improper shifting to 1st gear position</li> <li><input type="checkbox"/> DTC (1104, P0732) Improper shifting to 2nd gear position</li> <li><input type="checkbox"/> DTC (1105, P0733) Improper shifting to 3rd gear position</li> <li><input type="checkbox"/> DTC (1106, P0734) Improper shifting to 4th gear position or TCC</li> </ul>	EC section		
	<ul style="list-style-type: none"> <li><input type="checkbox"/> Perform the Diagnostic Procedures marked in ROAD TESTING. Refer to the Symptom Chart when you perform the procedures. (The chart also shows some other possible symptoms and the components inspection orders.)</li> </ul>	AT-114		
	<ul style="list-style-type: none"> <li><input type="checkbox"/> Erase DTC from A/T control unit and ECM memories.</li> </ul>	AT-51		
	<p>Perform FINAL CHECK. If NG, go back to "CHECK A/T FLUID".</p> <ul style="list-style-type: none"> <li><input type="checkbox"/> Stall test — Mark possible damaged components/others. <table style="width: 100%; border: none;"> <tr> <td style="width: 50%; vertical-align: top;"> <ul style="list-style-type: none"> <li><input type="checkbox"/> Torque converter one-way clutch</li> <li><input type="checkbox"/> Reverse clutch</li> <li><input type="checkbox"/> Forward clutch</li> <li><input type="checkbox"/> Overrun clutch</li> <li><input type="checkbox"/> Forward one-way clutch</li> </ul> </td> <td style="width: 50%; vertical-align: top;"> <ul style="list-style-type: none"> <li><input type="checkbox"/> Low &amp; reverse brake</li> <li><input type="checkbox"/> Low one-way clutch</li> <li><input type="checkbox"/> Engine</li> <li><input type="checkbox"/> Line pressure is low</li> <li><input type="checkbox"/> Clutches and brakes except high clutch and brake band are OK</li> </ul> </td> </tr> </table> </li> <li><input type="checkbox"/> Pressure test — Suspected parts:</li> </ul>	<ul style="list-style-type: none"> <li><input type="checkbox"/> Torque converter one-way clutch</li> <li><input type="checkbox"/> Reverse clutch</li> <li><input type="checkbox"/> Forward clutch</li> <li><input type="checkbox"/> Overrun clutch</li> <li><input type="checkbox"/> Forward one-way clutch</li> </ul>	<ul style="list-style-type: none"> <li><input type="checkbox"/> Low &amp; reverse brake</li> <li><input type="checkbox"/> Low one-way clutch</li> <li><input type="checkbox"/> Engine</li> <li><input type="checkbox"/> Line pressure is low</li> <li><input type="checkbox"/> Clutches and brakes except high clutch and brake band are OK</li> </ul>	AT-109
<ul style="list-style-type: none"> <li><input type="checkbox"/> Torque converter one-way clutch</li> <li><input type="checkbox"/> Reverse clutch</li> <li><input type="checkbox"/> Forward clutch</li> <li><input type="checkbox"/> Overrun clutch</li> <li><input type="checkbox"/> Forward one-way clutch</li> </ul>	<ul style="list-style-type: none"> <li><input type="checkbox"/> Low &amp; reverse brake</li> <li><input type="checkbox"/> Low one-way clutch</li> <li><input type="checkbox"/> Engine</li> <li><input type="checkbox"/> Line pressure is low</li> <li><input type="checkbox"/> Clutches and brakes except high clutch and brake band are OK</li> </ul>			

## Remarks

### FAIL-SAFE

The A/T control unit has an electronic Fail-Safe (limp home mode). This allows the vehicle to be driven even if a major electrical input/output device circuit is damaged.

Under Fail-Safe, the vehicle always runs in third gear with shift lever position of 1, 2 or D. Customer may say "Sluggish, poor acceleration".

When Fail-Safe operation occurs the next time the key is turned to the ON position, the OD OFF indicator lamp will blink for about 8 seconds. (For diagnosis, refer to AT-26.)

Fail-Safe may activate without electrical circuit damages if the vehicle is driven under extreme conditions (such as excessive wheel spins and emergency braking immediately afterwards). In this case, turn key OFF for 5 seconds and then ON to recover normal shift pattern.

The blinking of the OD OFF indicator lamp for about 8 seconds will appear only once and be cleared. The customer may resume normal driving conditions by chance.

Always follow the "WORK FLOW" (Refer to AT-15).

The SELF-DIAGNOSIS results will be as follows:

The first SELF-DIAGNOSIS will indicate the damage of the vehicle speed sensor or the revolution sensor.

During the next SELF-DIAGNOSIS performed after checking the sensor, no damages will be indicated.

### ATF COOLER SERVICE

Flash or replace ATF cooler if excessive foreign material is found in oil pan or clogging strainer.

VQ30DE engine (RE4F04A/RE4F04V) ... fin type cooler

Replace radiator lower tank (which includes ATF cooler) with a new one and flush cooler line using cleaning solvent and compressed air.

### OBD-II SELF-DIAGNOSIS

- A/T self-diagnosis is performed by the A/T control unit in combination with the ECM. The results can be read through the blinking pattern of the OD OFF indicator or the malfunction indicator lamp (MIL). Refer to the table on AT-46 for the indicator used to display each self-diagnostic result.

- The self-diagnostic results indicated by the MIL are automatically stored in both the ECM and A/T control unit memories.

**Always perform the procedure "HOW TO ERASE DTC" on AT-51 to complete the repair and avoid unnecessary blinking of the MIL.**

- The following self-diagnostic items can be detected using ECM self-diagnostic results mode\* only when the OD OFF indicator lamp does not indicate any malfunctions.

-Improper shifting to 1st, 2nd, 3rd, or 4th gear position

-Improper torque converter clutch operation.

\*: Refer to EC section ["Malfunction Indicator Lamp (MIL)", "ON-BOARD DIAGNOSTIC SYSTEM DESCRIPTION"].

GI

MA

EM

LG

EC

FE

CL

MT

AT

FA

RA

BR

ST

RS

BT

HA

EL

IDX

# TROUBLE DIAGNOSES

## Diagnostic Trouble Code (DTC) Chart

### A/T RELATED ITEMS

Diagnostic trouble code No.		Detected items (Screen terms for CONSULT, "SELF-DIAG RESULTS" mode)	Malfunction is detected when ...
CONSULT GST	MIL		
P0705	1101	Inhibitor switch circuit (INHIBITOR SWITCH)	<ul style="list-style-type: none"> <li>• A/T control unit does not receive the correct voltage signal from the switch based on the gear position.</li> </ul>
P0710	1208	Fluid temperature sensor (FLUID TEMP SENSOR)	<ul style="list-style-type: none"> <li>• A/T control unit receives an excessively low or high voltage from the sensor.</li> </ul>
P0720	1102	Revolution sensor (VHCL SPEED SEN-A/T)	<ul style="list-style-type: none"> <li>• A/T control unit does not receive the proper voltage signal from the sensor.</li> </ul>
P0725	1207	Engine speed signal (ENGINE SPEED SIG)	<ul style="list-style-type: none"> <li>• A/T control unit does not receive the proper voltage signal from the ECM.</li> </ul>
P0731	1103	Improper shifting to 1st gear position (A/T 1ST SIGNAL)	<ul style="list-style-type: none"> <li>• A/T can not be shifted to the 1st gear position even if electrical circuit is good.</li> </ul>
P0732	1104	Improper shifting to 2nd gear position (A/T 2ND SIGNAL)	<ul style="list-style-type: none"> <li>• A/T can not be shifted to the 2nd gear position even if electrical circuit is good.</li> </ul>
P0733	1105	Improper shifting to 3rd gear position (A/T 3RD SIGNAL)	<ul style="list-style-type: none"> <li>• A/T can not be shifted to the 3rd gear position even if electrical circuit is good.</li> </ul>
P0734	1106	Improper shifting to 4th gear position or TCC (A/T 4TH SIGNAL OR TCC)	<ul style="list-style-type: none"> <li>• A/T can not be shifted to the 4th gear position or perform lock-up even electrical circuit is good.</li> </ul>
P0740	1204	T/C clutch solenoid valve (TOR CONV CLUTCH SV)	<ul style="list-style-type: none"> <li>• A/T control unit detects the improper voltage drop when it tries to operate the solenoid valve.</li> </ul>
P0745	1205	Line pressure solenoid valve (LINE PRESSURE SV)	<ul style="list-style-type: none"> <li>• A/T control unit detects the improper voltage drop when it tries to operate the solenoid valve.</li> </ul>
P0750	1108	Shift solenoid valve A (SHIFT SOLENOID/V A)	<ul style="list-style-type: none"> <li>• A/T control unit detects the improper voltage drop when it tries to operate the solenoid valve.</li> </ul>
P0755	1201	Shift solenoid valve B (SHIFT SOLENOID/V B)	<ul style="list-style-type: none"> <li>• A/T control unit detects the improper voltage drop when it tries to operate the solenoid valve.</li> </ul>
P1705	1206	Throttle position sensor (THRTL POSI SEN-A/T)	<ul style="list-style-type: none"> <li>• A/T control unit receives an excessively low or high voltage from the sensor.</li> </ul>
P1760	1203	Overrun clutch solenoid valve (OVERRUN CLUTCH S/V)	<ul style="list-style-type: none"> <li>• A/T control unit detects the improper voltage drop when it tries to operate the solenoid valve.</li> </ul>

# TROUBLE DIAGNOSES

## Diagnostic Trouble Code (DTC) Chart (Cont'd)

Check Items (Possible Cause)	DTC Confirmation Procedure Quick Ref.	Fail Safe System	MIL Illumination	Reference Page	
<ul style="list-style-type: none"> <li>• Harness or connectors (The switch circuit is open or shorted.)</li> <li>• Inhibitor switch</li> </ul>	DRIVING (pattern 1)	—	2 trip	AT-73	GI
<ul style="list-style-type: none"> <li>• Harness or connectors (The sensor circuit is open or shorted.)</li> <li>• Fluid temperature sensor</li> </ul>	DRIVING (pattern 6)	X	2 trip	AT-66	MA
<ul style="list-style-type: none"> <li>• Harness or connectors (The sensor circuit is open or shorted.)</li> <li>• Revolution sensor</li> </ul>	DRIVING (pattern 2)	X	2 trip	AT-52	EM
<ul style="list-style-type: none"> <li>• Harness or connectors (The signal circuit is open or shorted.)</li> </ul>	DRIVING (pattern 5)	X	2 trip	AT-69	LC
<ul style="list-style-type: none"> <li>• Shift solenoid valve A</li> <li>• Shift solenoid valve B</li> <li>• Overrun clutch solenoid valve</li> <li>• Line pressure solenoid valve</li> <li>• Each clutch</li> <li>• Hydraulic control circuit</li> </ul> <hr style="border-top: 1px dashed black;"/> <ul style="list-style-type: none"> <li>• T/C clutch solenoid valve</li> </ul>	DRIVING (pattern 3)	—	2 trip	AT-77	FE
				AT-79	CL
				AT-81	MT
				AT-83	AT
<ul style="list-style-type: none"> <li>• Harness or connectors (The solenoid circuit is open or shorted.)</li> <li>• T/C clutch solenoid valve</li> </ul>	IGN: ON	X	2 trip	AT-64	FA
<ul style="list-style-type: none"> <li>• Harness or connectors (The solenoid circuit is open or shorted.)</li> <li>• Line pressure solenoid valve</li> </ul>	IGN: ON	X	2 trip	AT-71	RA
<ul style="list-style-type: none"> <li>• Harness or connectors (The solenoid circuit is open or shorted.)</li> <li>• Shift solenoid valve A</li> </ul>	IGN: ON	X	2 trip	AT-58	BR
<ul style="list-style-type: none"> <li>• Harness or connectors (The solenoid circuit is open or shorted.)</li> <li>• Shift solenoid valve B</li> </ul>	IGN: ON	X	2 trip	AT-60	ST
<ul style="list-style-type: none"> <li>• Harness or connectors (The sensor circuit is open or shorted.)</li> <li>• Throttle position sensor</li> </ul>	DRIVING (pattern 4)	X	2 trip	AT-56	RS
<ul style="list-style-type: none"> <li>• Harness or connectors (The solenoid circuit is open or shorted.)</li> <li>• Overrun clutch solenoid valve</li> </ul>	IGN: ON	X	2 trip	AT-62	BT

\*1: DRIVING pattern 1-6 means as follows:  
 Pattern 1 should meet b and c.  
 Pattern 2 should meet a and c.  
 Pattern 3 should meet a through e.  
 Pattern 4 should meet a and b.  
 Pattern 5 should meet a through c.  
 Pattern 6 should meet a through d.

a: Selector lever is in "D" position.  
 b: Vehicle speed is over 10 km/h (6 MPH).  
 c: Throttle opening is over 1/8.  
 d: Engine speed is over 450 rpm.  
 e: A/T fluid temperature is 20 - 120°C (68 - 248°F).

# TROUBLE DIAGNOSES

## Diagnosis by CONSULT

### NOTICE

1. The CONSULT electrically displays shift timing and lock-up timing (that is, operation timing of each solenoid).  
Check for time difference between actual shift timing and the CONSULT display. If the difference is noticeable, mechanical parts (except solenoids, sensors, etc.) may be malfunctioning. Check mechanical parts using applicable diagnostic procedures.
2. Shift schedule (which implies gear position) displayed on CONSULT and that indicated in Service Manual may differ slightly. This occurs because of the following reasons:
  - Actual shift schedule has more or less tolerance or allowance,
  - Shift schedule indicated in Service Manual refers to the point where shifts start, and
  - Gear position displayed on CONSULT indicates the point where shifts are completed.
3. Shift solenoid valve "A" or "B" is displayed on CONSULT at the start of shifting. Gear position is displayed upon completion of shifting (which is computed by A/T control unit).
4. Additional CONSULT information can be found in the Operation Manual supplied with the CONSULT unit.

### SELF-DIAGNOSTIC RESULT TEST MODE

Refer to AT-46.

### DATA MONITOR DIAGNOSTIC TEST MODE

Item	Display	Monitor item		Description	Remarks
		ECU input signals	Main signals		
Vehicle speed sensor 1 (A/T) (Revolution sensor)	VHCL/S SE●A/T [km/h] or [mph]	X	—	<ul style="list-style-type: none"> <li>• Vehicle speed computed from signal of revolution sensor is displayed.</li> </ul>	When racing engine in N or P position with vehicle stationary, CONSULT data may not indicate 0 km/h (0 MPH).
Vehicle speed sensor 2 (Meter)	VHCL/S SE●MTR [km/h] or [mph]	X	—	<ul style="list-style-type: none"> <li>• Vehicle speed computed from signal of vehicle speed sensor is displayed.</li> </ul>	Vehicle speed display may not be accurate under approx. 10 km/h (6 MPH). It may not indicate 0 km/h (0 MPH) when vehicle is stationary.
Throttle position sensor	THRTL POS SEN [V]	X	—	<ul style="list-style-type: none"> <li>• Throttle position sensor signal voltage is displayed.</li> </ul>	
A/T fluid temperature sensor	FLUID TEMP SEN [V]	X	—	<ul style="list-style-type: none"> <li>• A/T fluid temperature sensor signal voltage is displayed.</li> <li>• Signal voltage lowers as fluid temperature rises.</li> </ul>	
Battery voltage	BATTERY VOLT [V]	X	—	<ul style="list-style-type: none"> <li>• Source voltage of control unit is displayed.</li> </ul>	
Engine speed	ENGINE SPEED [rpm]	X	X	<ul style="list-style-type: none"> <li>• Engine speed, computed from engine speed signal, is displayed.</li> </ul>	Engine speed display may not be accurate under approx. 800 rpm. It may not indicate 0 rpm even when engine is not running.
Overdrive switch	OVERDRIVE SW [ON/OFF]	X	—	<ul style="list-style-type: none"> <li>• ON/OFF state computed from signal of overdrive SW is displayed.</li> </ul>	
P/N position switch	P/N POSI SW [ON/OFF]	X	—	<ul style="list-style-type: none"> <li>• ON/OFF state computed from signal of P/N position SW is displayed.</li> </ul>	
R position switch	R POSITION SW [ON/OFF]	X	—	<ul style="list-style-type: none"> <li>• ON/OFF state computed from signal of R position SW is displayed.</li> </ul>	
D position switch	D POSITION SW [ON/OFF]	X	—	<ul style="list-style-type: none"> <li>• ON/OFF state computed from signal of D position SW is displayed.</li> </ul>	
2 position switch	2 POSITION SW [ON/OFF]	X	—	<ul style="list-style-type: none"> <li>• ON/OFF status, computed from signal of 2 position SW, is displayed.</li> </ul>	

# TROUBLE DIAGNOSES

## Diagnosis by CONSULT (Cont'd)

Item	Display	Monitor item		Description	Remarks
		ECU input signals	Main signals		
1 position switch	1 POSITION SW [ON/OFF]	X	—	• ON/OFF status, computed from signal of 1 position SW, is displayed.	
ASCD-cruise signal	ASCD●CRUISE [ON/OFF]	X	—	• Status of ASCD cruise signal is displayed. ON ... Cruising state OFF ... Normal running state	• This is displayed even when no ASCD is mounted.
ASCD-OD cut signal	ASCD●OD CUT [ON/OFF]	X	—	• Status of ASCD●OD release signal is displayed. ON ... OD released OFF ... OD not released	• This is displayed even when no ASCD is mounted.
Closed throttle position switch	CLOSED THL/SW [ON/OFF]	X	—	• ON/OFF status, computed from signal of closed throttle position SW, is displayed.	
Wide open throttle position switch	W/O THRL/P-SW [ON/OFF]	X	—	• ON/OFF status, computed from signal of wide open throttle position SW, is displayed.	
Hold switch	HOLD SW [ON/OFF]	X	—	• ON/OFF status, computed from signal of hold SW, is displayed.	
Gear position	GEAR	—	X	• Gear position data used for computation by control unit, is displayed.	
Selector lever position	SLCT LVR POSI	—	X	• Selector lever position data, used for computation by control unit, is displayed.	• A specific value used for control is displayed if fail-safe is activated due to error.
Vehicle speed	VEHICLE SPEED [km/h] or [mph]	—	X	• Vehicle speed data, used for computation by control unit, is displayed.	
Throttle position	THROTTLE POSI [°]	—	X	• Throttle position data, used for computation by control unit, is displayed.	• A specific value used for control is displayed if fail-safe is activated due to error.
Line pressure duty	LINE PRES DTY [%]	—	X	• Control value of line pressure solenoid valve, computed by control unit from each input signal, is displayed.	
Torque converter clutch solenoid valve duty	TCC S/V DUTY [%]	—	X	• Control value of torque converter clutch solenoid valve, computed by control unit from each input signal, is displayed.	
Shift solenoid valve A	SHIFT S/V A [ON/OFF]	—	X	• Control value of shift solenoid valve A, computed by control unit from each input signal, is displayed.	Control value of solenoid is displayed even if solenoid circuit is disconnected. The "OFF" signal is displayed if solenoid circuit is shorted.
Shift solenoid valve B	SHIFT S/V B [ON/OFF]	—	X	• Control value of shift solenoid valve B, computed by control unit from each input signal, is displayed.	
Overrun clutch solenoid valve	OVERRUN/C S/V [ON/OFF]	—	X	• Control value of overrun clutch solenoid valve computed by control unit from each input signal is displayed.	
Self-diagnosis display lamp (OD OFF indicator lamp)	SELF-D DP LMP [ON/OFF]	—	X	• Control status of OD OFF indicator lamp is displayed.	

X: Applicable

—: Not applicable

# TROUBLE DIAGNOSES

## Diagnosis by CONSULT (Cont'd)

### DATA ANALYSIS

Item	Display form	Meaning
Torque converter clutch solenoid valve duty	Approximately 4%	Lock-up "OFF"
	↓	↓
	Approximately 94%	Lock-up "ON"
Line pressure solenoid valve duty	Approximately 0%	Low line-pressure (Small throttle opening)
	↓	↓
	Approximately 95%	High line-pressure (Large throttle opening)
Throttle position sensor	Approximately 0.5V	Fully-closed throttle
	Approximately 4V	Fully-open throttle
A/T fluid temperature sensor	Approximately 1.5V	Cold [20°C (68°F)]
	↓	↓
	Approximately 0.5V	Hot [80°C (176°F)]

Gear position	1	2	3	4
Shift solenoid valve A	ON	OFF	OFF	ON
Shift solenoid valve B	ON	ON	OFF	OFF



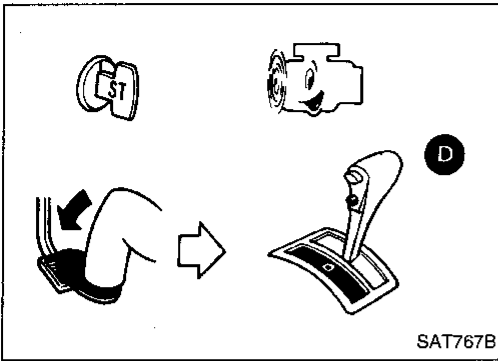

## Preliminary Check

### A/T FLUID CHECK

#### Fluid leakage check

1. Clean area suspected of leaking. — for example, mating surface of converter housing and transmission case.
2. Start engine, apply foot brake, place selector lever in “D” position and wait a few minutes.
3. Stop engine.

GI

MA

EM

LC

EC

FE

CL

MT

AT

FA

RA

BR

ST

RS

BT

HA

EL

IDX

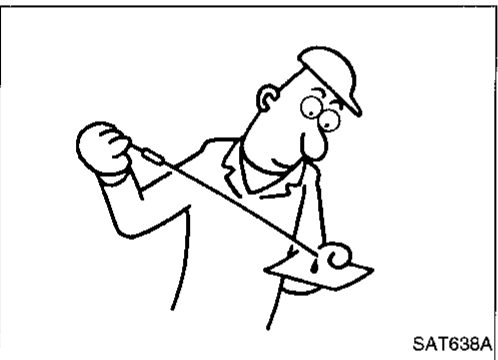
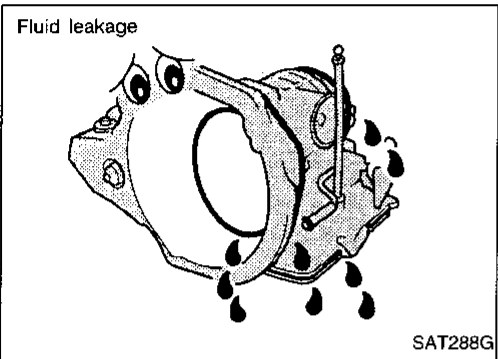

4. Check for fresh leakage.

#### Fluid condition check

Fluid color	Suspected problem
Dark or black with burned odor	Wear of frictional material
Milky pink	Water contamination — Road water entering through filler tube or breather
Varnished fluid, light to dark brown and tacky	Oxidation — Over or under filling, — Overheating

**Fluid level check — Refer to MA section (CHASSIS AND BODY MAINTENANCE).**

### ROAD TEST PROCEDURE

1. Check before engine is started.



2. Check at idle.



3. Cruise test.

SAT786A

### ROAD TEST

#### Description

- The purpose of a road test is to analyze overall performance and determine causes of problems.
- The road test consists of the following three parts:
  1. Check before engine is started
  2. Check at idle
  3. Cruise test

- Before road test, familiarize yourself with all test procedures and items to check.
- Conduct tests on all items until specified symptom is found. Troubleshoot items which check out No Good after road test. Refer to “Self-diagnosis” and “Diagnostic Procedure”, AT-46, 87.

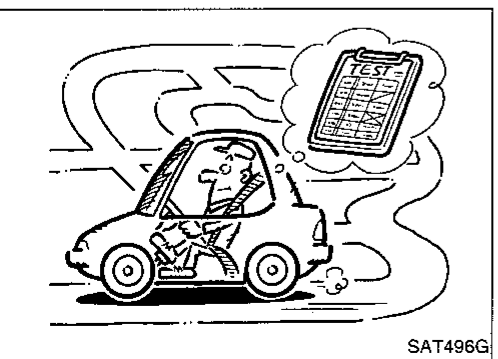

# TROUBLE DIAGNOSES

## Preliminary Check (Cont'd)

### 1. Check before engine is started

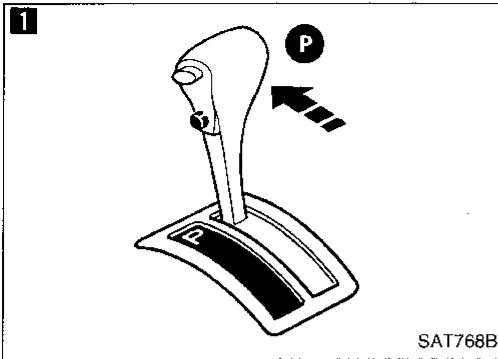

- 1 2**
1. Park vehicle on flat surface.
  2. Turn ignition switch to "OFF" position.
  3. Move selector lever to "P" position.
  4. Set overdrive switch to "ON" position.
  5. Turn ignition switch to "ON" position.  
(Do not start engine.)
  6. Does OD OFF indicator lamp come on for about 2 seconds?

No → Go to Diagnostic Procedure 1, AT-87.

Yes

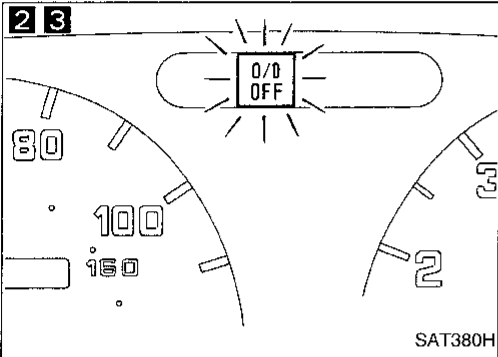

- 3**
- Does OD OFF indicator lamp flicker for about 8 seconds?

Yes → Perform self-diagnosis. Refer to SELF-DIAGNOSIS PROCEDURE, AT-46.

No

Turn ignition switch to "OFF" position.

Perform self-diagnosis and note NG items:  
Refer to SELF-DIAGNOSIS PROCEDURE, AT-46.

Go to "2. Check at idle", AT-27.

# TROUBLE DIAGNOSES

## Preliminary Check (Cont'd)

### 2. Check at idle

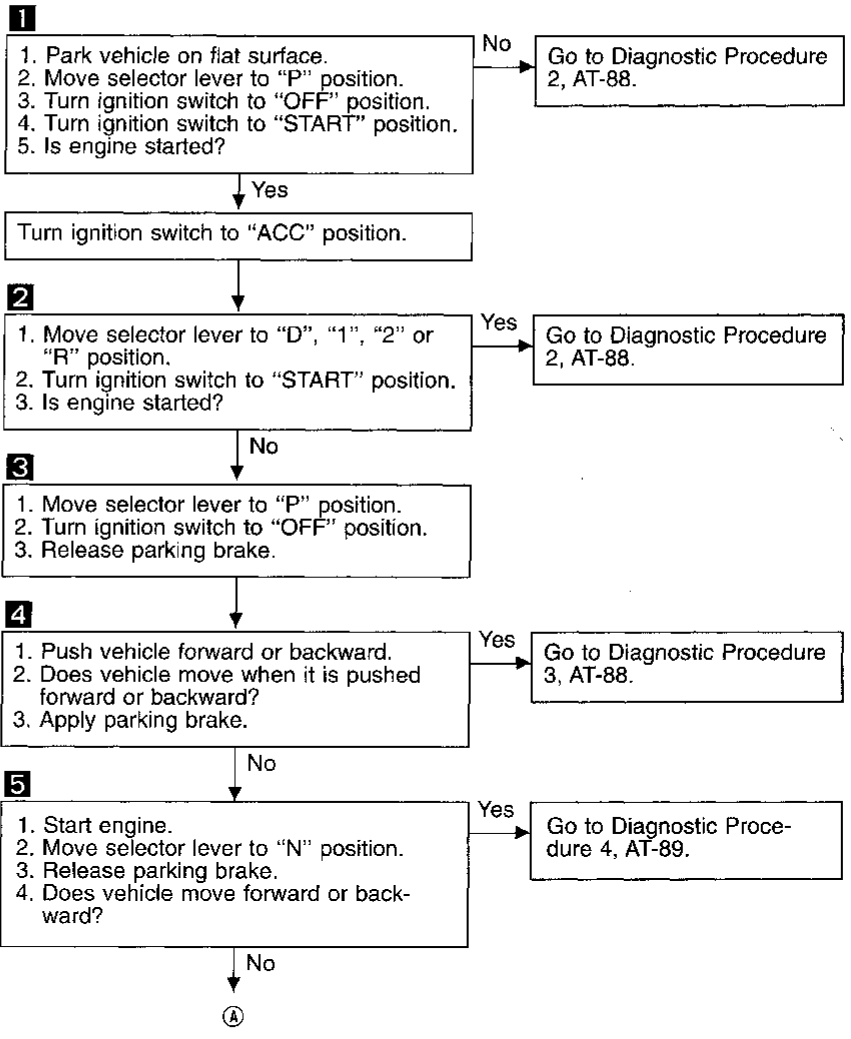
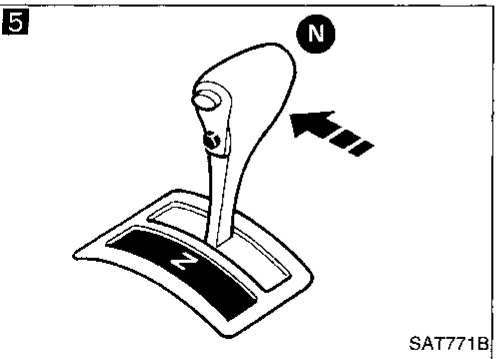
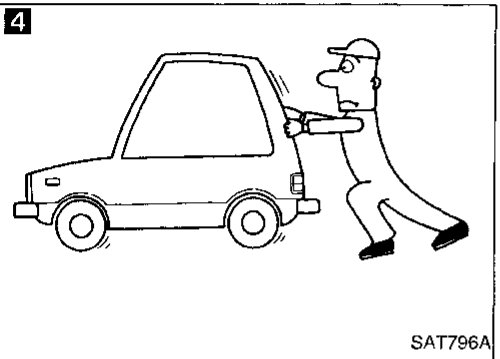
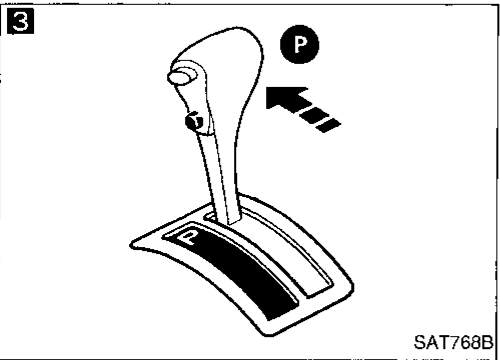
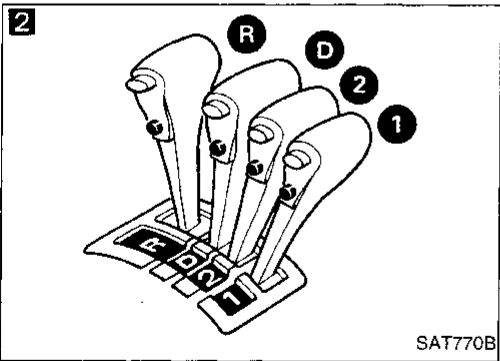
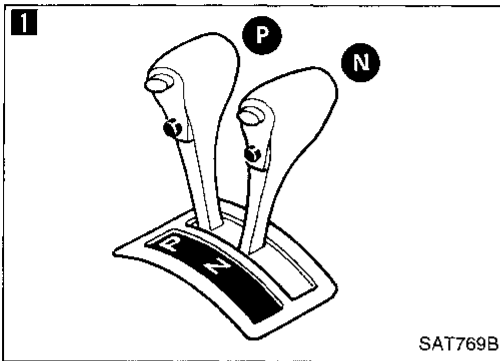

GI  
MA  
EM  
LC  
EC  
FE  
CL  
MT  
AT  
FA  
RA  
BR  
ST  
RS  
BT  
HA  
EL  
IDX

# TROUBLE DIAGNOSES

## Preliminary Check (Cont'd)

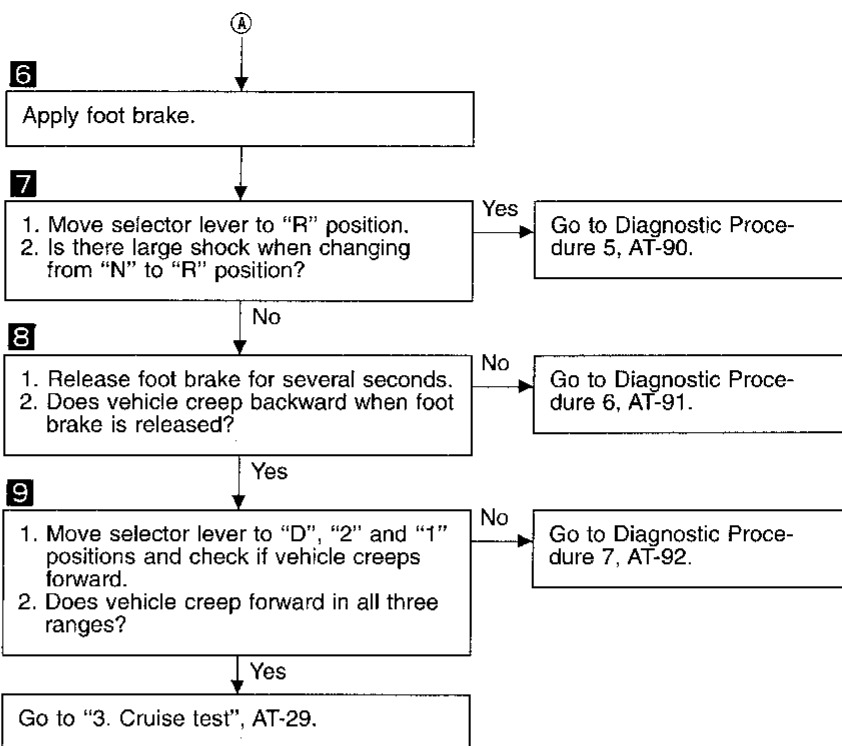
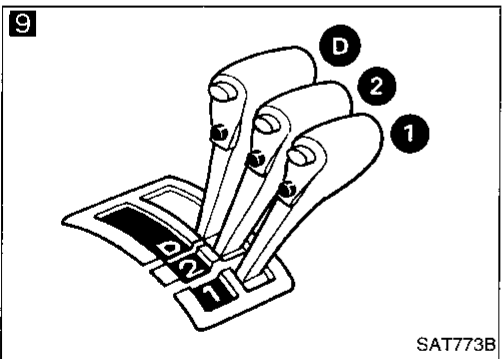
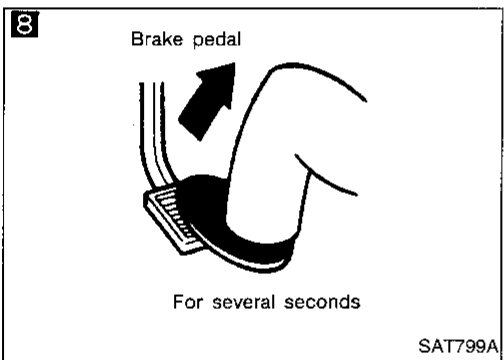
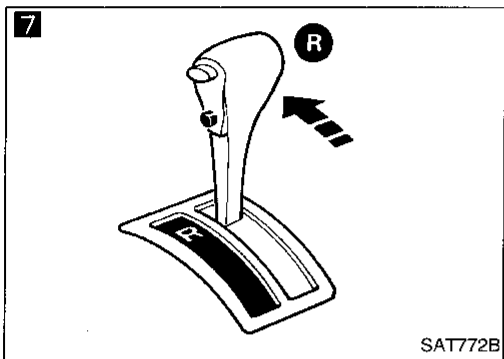
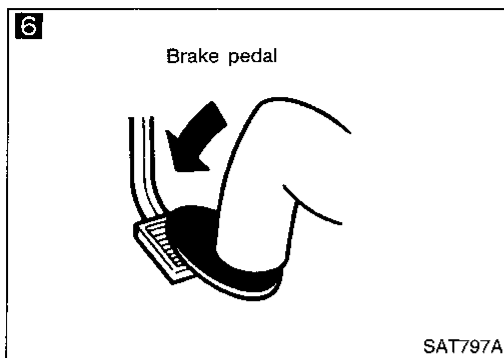

# TROUBLE DIAGNOSES

## Preliminary Check (Cont'd)

### 3. Cruise test

- Check all items listed in Parts 1 through 3.

#### With CONSULT

- Using CONSULT, conduct a cruise test and record the result.
- Print the result and ensure that shifts and lock-ups take place as per "Shift Schedule".

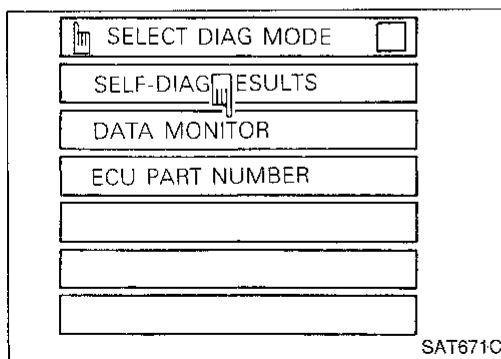
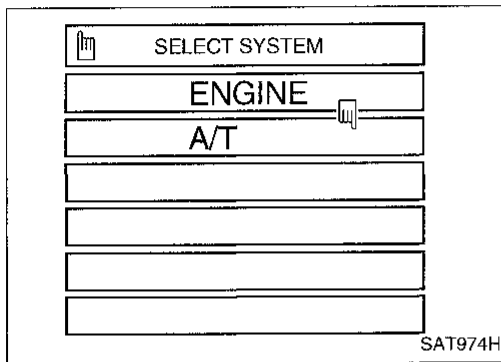
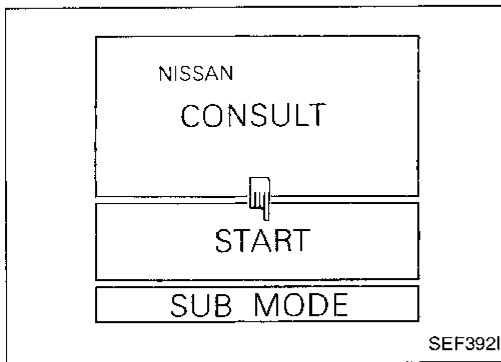
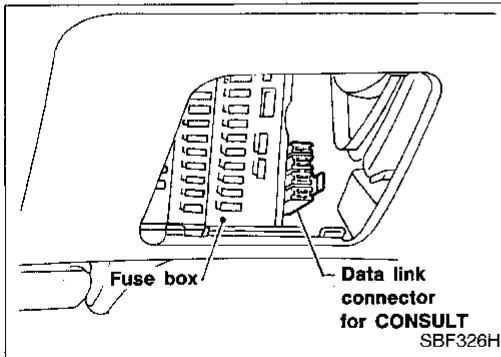
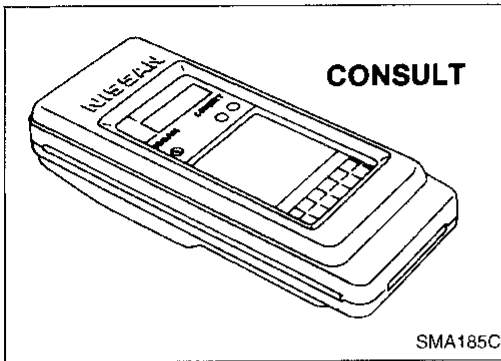

### CONSULT setting procedure

1. Turn off ignition switch.
2. Connect "CONSULT" to Data link connector for CONSULT. Data link connector for CONSULT is located in left side dash panel.

3. Turn on ignition switch.
4. Touch "START".

5. Touch "A/T".

6. Touch "DATA MONITOR".

GI

MA

EM

LC

EC

FE

CL

MT

**AT**

FA

RA

BR

ST

RS

BT

HA

EL

IDX

# TROUBLE DIAGNOSES

## Preliminary Check (Cont'd)

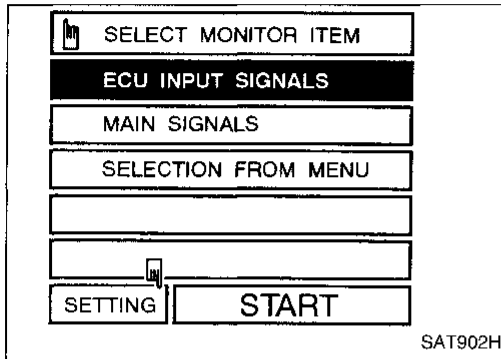

7. Touch "SETTING" to set recording condition.

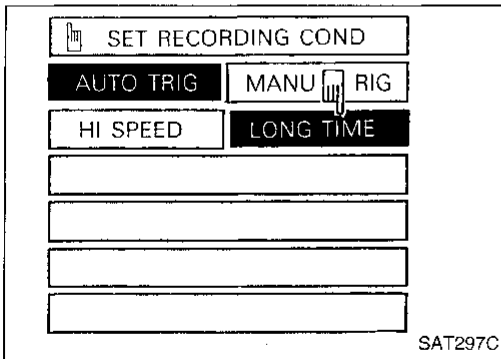

8. Touch "LONG TIME" and "ENTER" key.

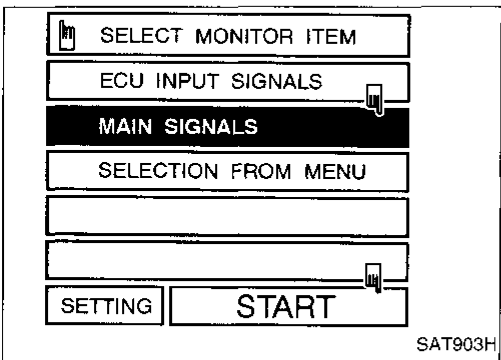

9. Go back to SELECT MONITOR ITEM and touch "MAIN SIGNALS".

10. Touch "START".

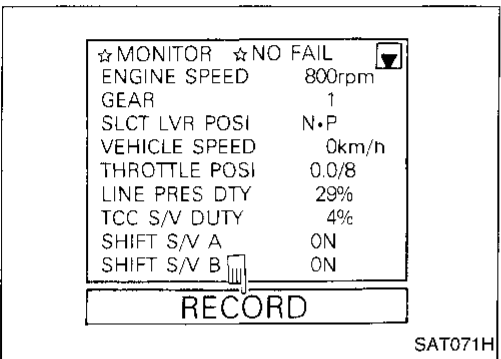

11. When performing cruise test, touch "RECORD".

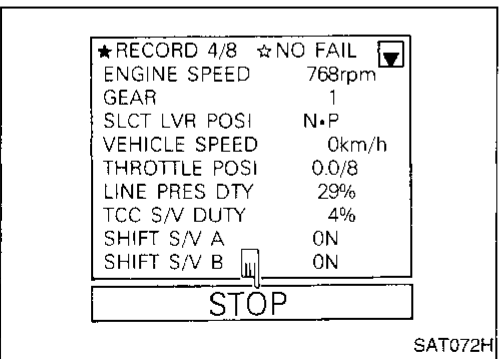

12. After finishing cruise test part 1, touch "STOP".

# TROUBLE DIAGNOSES

## Preliminary Check (Cont'd)

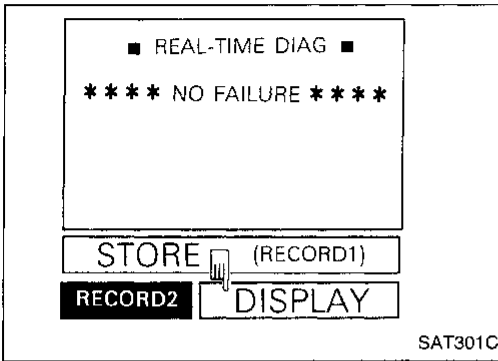

13. Touch "DISPLAY".

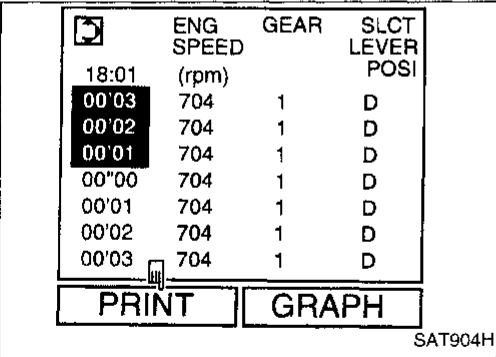

14. Touch "PRINT".

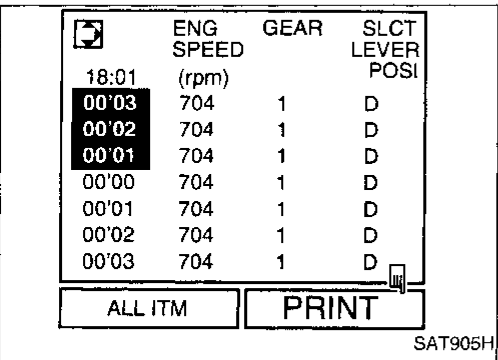

15. Touch "PRINT".

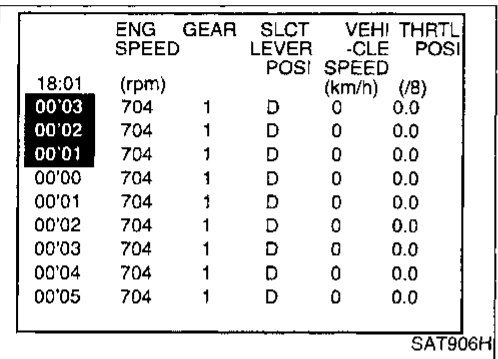

16. Check the monitor data printed out.

17. Continue cruise test part 2 and 3.

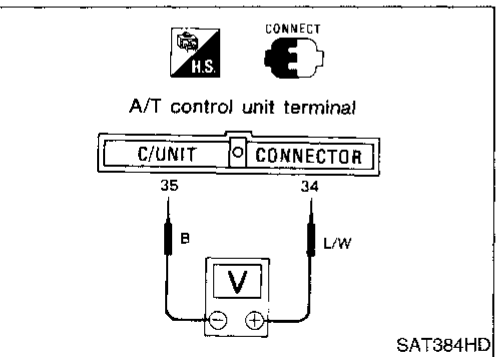

Without CONSULT

- Throttle position can be checked by voltage across terminals 34 and 35 of A/T control unit.

GI

MA

EM

LC

EC

FE

CL

MT

AT

FA

RA

BR

ST

RS

BT

HA

EL

IDX

# TROUBLE DIAGNOSES

## Preliminary Check (Cont'd)

### Cruise test — Part 1

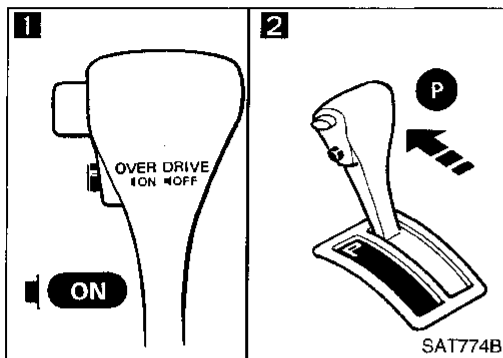

1. Drive vehicle for about 10 minutes to warm engine oil and ATF up to operating temperature.  
**ATF operating temperature:**  
 50 - 80°C (122 - 176°F)

1 2

1. Park vehicle on flat surface.  
 2. Set overdrive switch to "ON" position.  
 3. Move selector lever to "P" position.  
 4. Start engine.

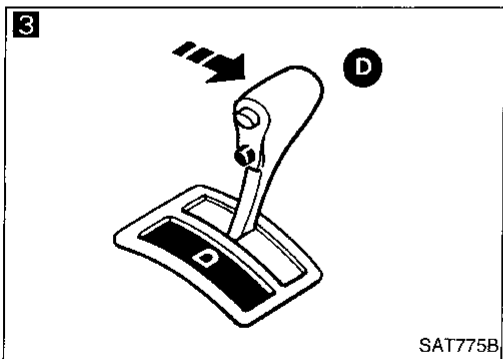

3 Move selector lever to "D" position.

4 Accelerate vehicle by slowly and constantly depressing accelerator pedal half-way.

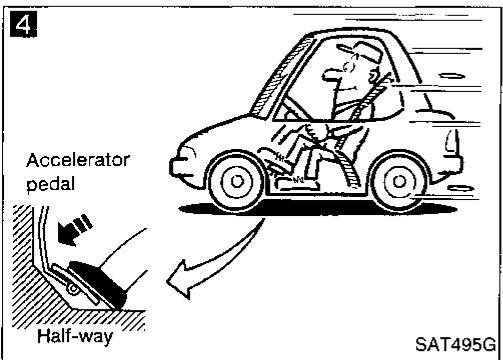

Does vehicle start from D<sub>1</sub>?  
**Read gear position.**

No → Go to Diagnostic Procedure 8, AT-93.

Yes

5 Does A/T shift from D<sub>1</sub> to D<sub>2</sub> at the specified speed?  
**Read gear position, throttle opening and vehicle speed.**  
**Specified speed when shifting from D<sub>1</sub> to D<sub>2</sub>:**  
 Refer to Shift schedule, AT-36.

No → Go to Diagnostic Procedure 9, AT-94.

Yes

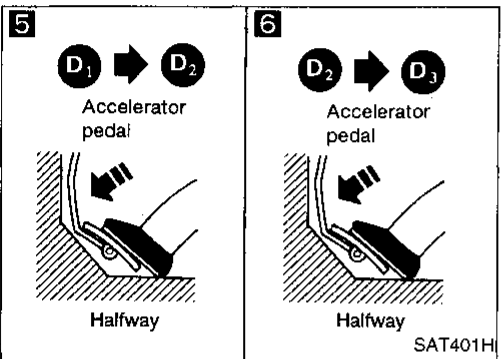

6 Does A/T shift from D<sub>2</sub> to D<sub>3</sub> at the specified speed?  
**Read gear position, throttle position and vehicle speed.**  
**Specified speed when shifting from D<sub>2</sub> to D<sub>3</sub>:**  
 Refer to Shift schedule, AT-36.

No → Go to Diagnostic Procedure 10, AT-95.

Yes

Ⓐ



# TROUBLE DIAGNOSES

## Preliminary Check (Cont'd)

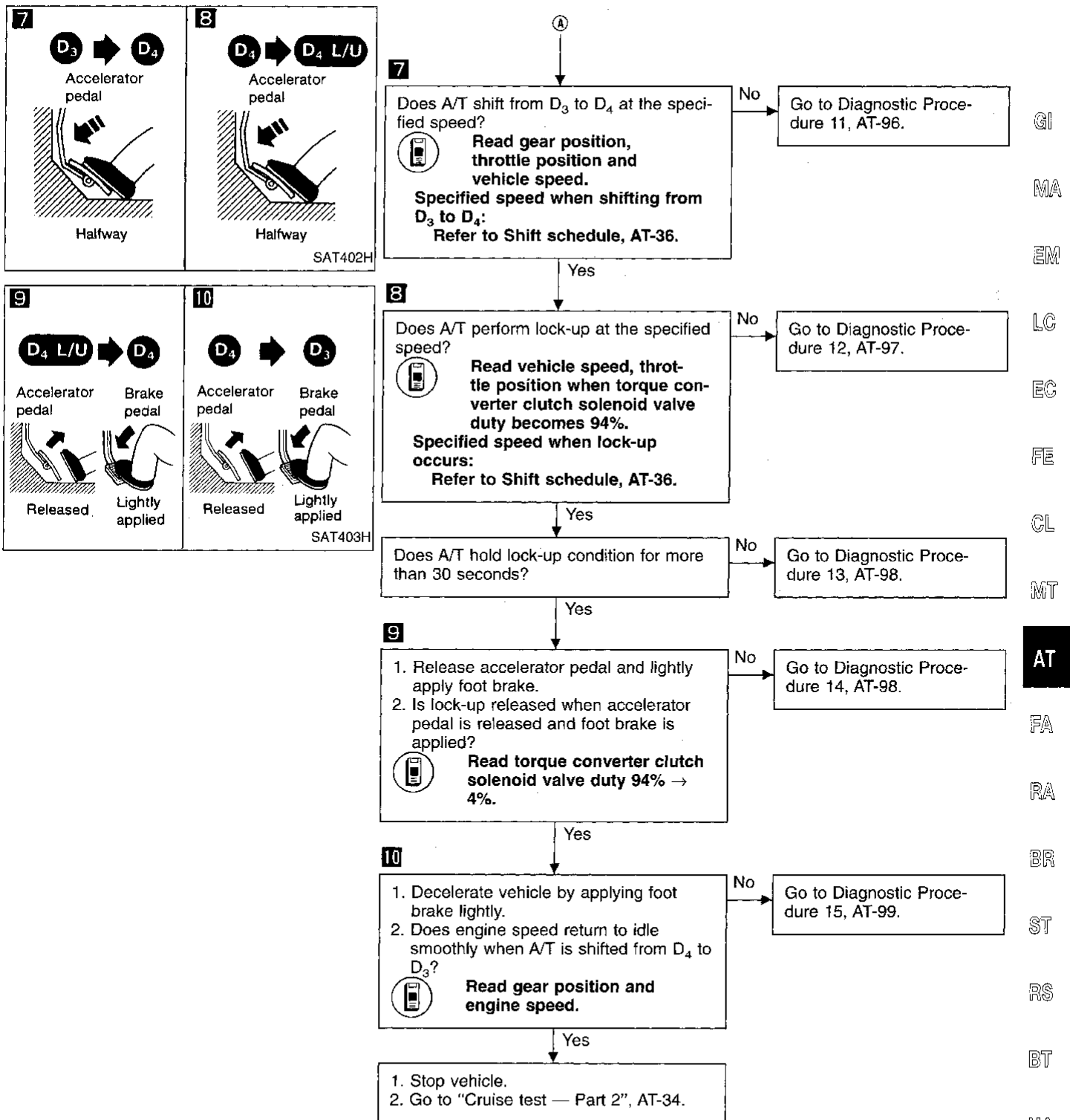

# TROUBLE DIAGNOSES

## Preliminary Check (Cont'd)

### Cruise test — Part 2

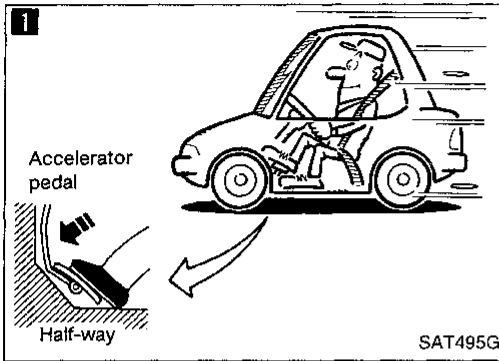

1. Confirm overdrive switch is in "ON" position.
2. Confirm selector lever is in "D" position.

**1**

1. Accelerate vehicle by half throttle again.
2. Does vehicle start from D<sub>1</sub>?

**Read gear position.**

No → Go to Diagnostic Procedure 16, AT-100.

**2**

1. Accelerate vehicle to 80 km/h (50 MPH).
2. Release accelerator pedal and then quickly depress it fully.
3. Does A/T shift from D<sub>4</sub> to D<sub>2</sub> as soon as accelerator pedal is depressed fully?

**Read gear position and throttle position.**

No → Go to Diagnostic Procedure 9, AT-94.

**3**

Does A/T shift from D<sub>2</sub> to D<sub>3</sub> at the specified speed?

**Read gear position, throttle position and vehicle speed.**

**Specified speed when shifting from D<sub>2</sub> to D<sub>3</sub>:**  
Refer to Shift schedule, AT-36.

No → Go to Diagnostic Procedure 10, AT-95.

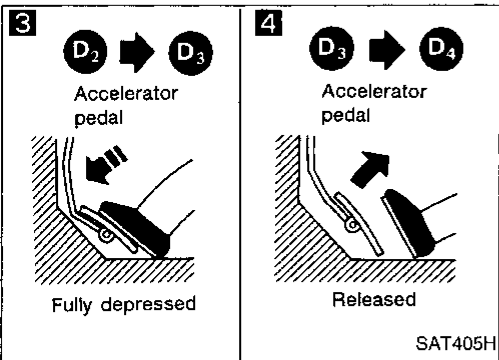
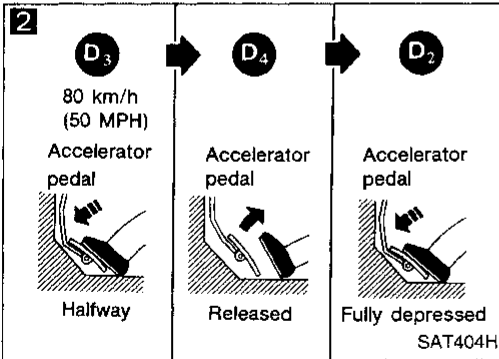

**4**

1. Release accelerator pedal after shifting from D<sub>2</sub> to D<sub>3</sub>.
2. Does A/T shift from D<sub>3</sub> to D<sub>4</sub> and does vehicle decelerate by engine brake?

**Read gear position, throttle position and vehicle speed.**

No → Go to Diagnostic Procedure 11, AT-96.

- 1. Stop vehicle.**  
**2. Go to "Cruise test — Part 3", AT-35.**

# TROUBLE DIAGNOSES

## Preliminary Check (Cont'd)

### Cruise test — Part 3

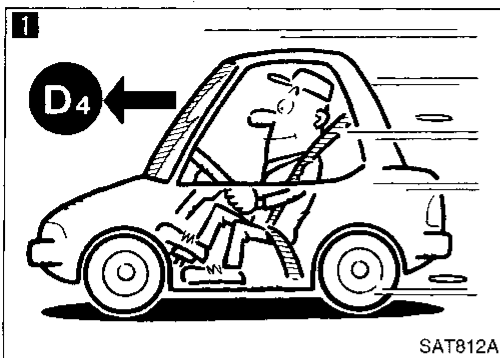

1. Confirm overdrive switch is in "ON" position.
2. Confirm selector lever is in "D" position.

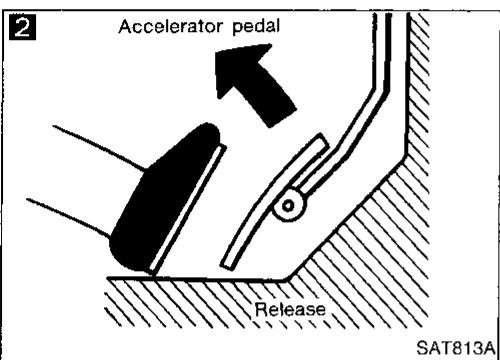

**1**  
Accelerate vehicle using half-throttle to D<sub>4</sub>.

**2**  
Release accelerator pedal.

**3**  
Set overdrive switch to "OFF" position while driving in D<sub>4</sub>.

**4**  
Does A/T shift from D<sub>4</sub> to D<sub>3</sub>?  
**Read gear position and vehicle speed.**

No → Go to Diagnostic Procedure 17, AT-100.

**5**  
Does vehicle decelerate by engine brake?

No → Go to Diagnostic Procedure 15, AT-99.

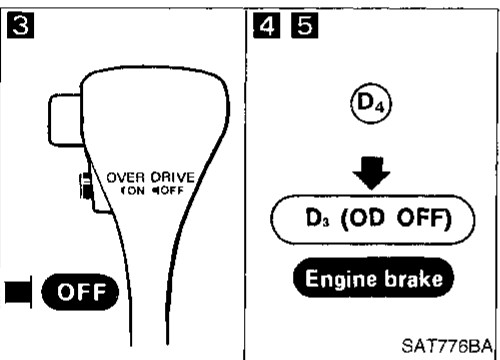

**6**  
Move selector lever from "D" to "2" position while driving in D<sub>3</sub>.

**7**  
Does A/T shift from D<sub>3</sub> to 2<sub>2</sub>?  
**Read gear position.**

No → Go to Diagnostic Procedure 18, AT-101.

**8**  
Does vehicle decelerate by engine brake?

No → Go to Diagnostic Procedure 15, AT-99.

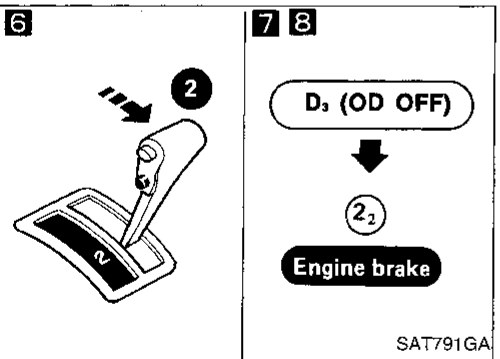

**9 10**  
1. Move selector lever from "2" to "1" position while driving in 2<sub>2</sub>.  
2. Does A/T shift from 2<sub>2</sub> to 1<sub>1</sub> position?  
**Read gear position.**

No → Go to Diagnostic Procedure 19, AT-101.

**11**  
Does vehicle decelerate by engine brake?

No → Go to Diagnostic Procedure 20, AT-101.

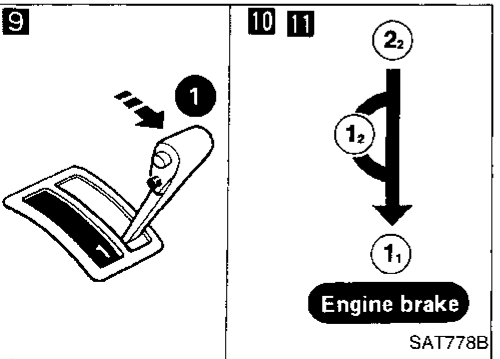

1. Stop vehicle.
2. Perform self-diagnosis. Refer to SELF-DIAGNOSTIC PROCEDURE, AT-46.

GI  
MA  
EM  
LC  
EC  
FE  
CL  
MT  
AT  
FA  
RA  
BR  
ST  
RS  
BT  
HA  
EL  
IDX

# TROUBLE DIAGNOSES

## Preliminary Check (Cont'd)

### SHIFT SCHEDULE

#### Vehicle speed when shifting gears

Throttle position	Shift pattern	Vehicle speed km/h (MPH)						
		D <sub>1</sub> → D <sub>2</sub>	D <sub>2</sub> → D <sub>3</sub>	D <sub>3</sub> → D <sub>4</sub>	D <sub>4</sub> → D <sub>3</sub>	D <sub>3</sub> → D <sub>2</sub>	D <sub>2</sub> → D <sub>1</sub>	1 <sub>2</sub> → 1 <sub>1</sub>
Full throttle	Comfort	61 - 69 (38 - 43)	113 - 121 (70 - 75)	177 - 185 (110 - 115)	173 - 181 (108 - 112)	103 - 111 (64 - 69)	54 - 62 (34 - 39)	61 - 69 (38 - 43)
	Auto power	61 - 69 (38 - 43)	113 - 121 (70 - 75)	177 - 185 (110 - 115)	173 - 181 (108 - 112)	103 - 111 (64 - 69)	54 - 62 (34 - 39)	61 - 69 (38 - 43)
Half throttle	Comfort	39 - 47 (24 - 29)	73 - 81 (45 - 50)	113 - 121 (70 - 75)	79 - 87 (49 - 54)	36 - 44 (22 - 27)	5 - 13 (3 - 8)	61 - 69 (38 - 43)
	Auto power	46 - 54 (29 - 34)	85 - 93 (53 - 58)	134 - 142 (83 - 88)	85 - 93 (53 - 58)	51 - 59 (32 - 37)	5 - 13 (3 - 8)	61 - 69 (38 - 43)

#### VEHICLE SPEED WHEN PERFORMING LOCK-UP (Reference value)

Model code No.		80X17	80X18
Vehicle speed	km/h (MPH)	49 - 65 (30 - 40)	
	Throttle position 1/8		

- Note:
- Lock-up vehicle speed indicates the speed in D<sub>4</sub> position.
  - Make sure that lock-up is released under the following conditions:
    - Throttle opening 0/8
    - Vehicle speed is less than 120 km/h (75 MPH).
  - Perform lock-up inspection after warming up engine.
  - Lock-up vehicle speed may vary depending on the driving conditions and circumstances.

# TROUBLE DIAGNOSES

## A/T Electrical Parts Location

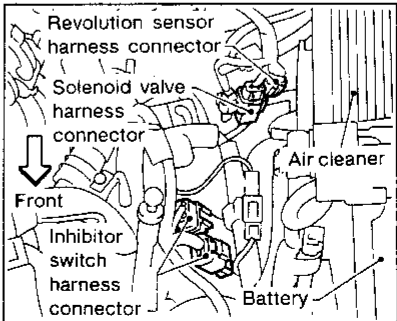
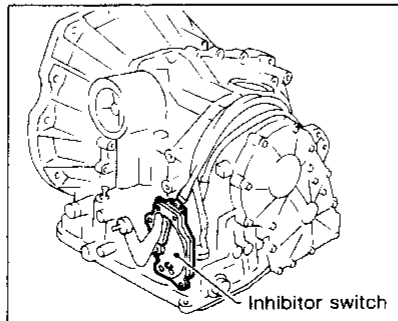
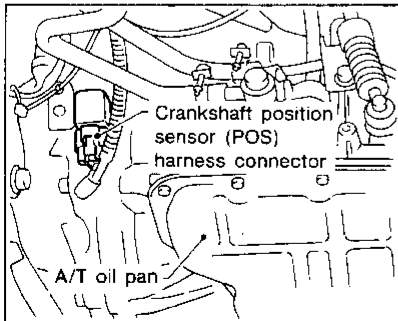
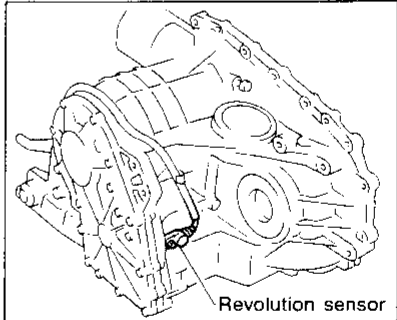
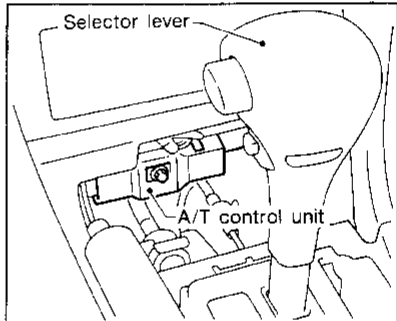
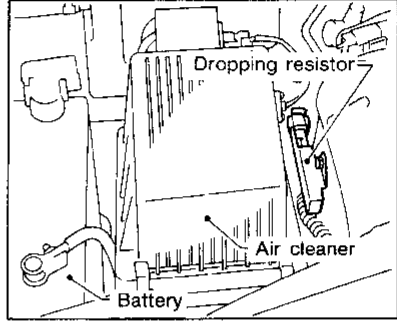
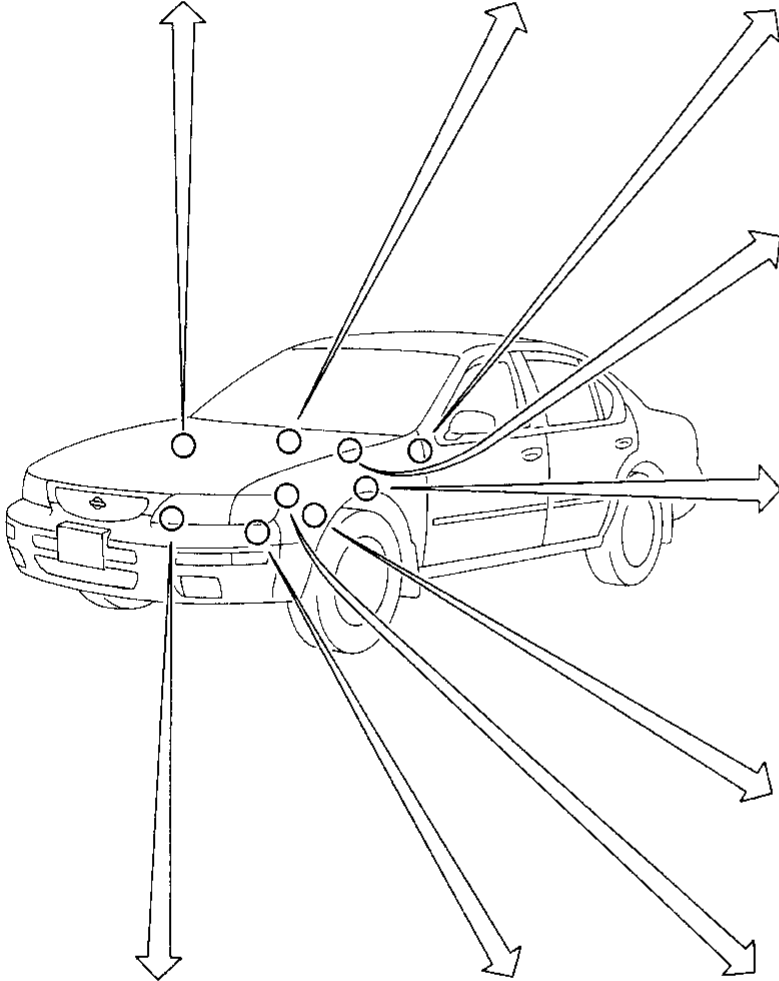
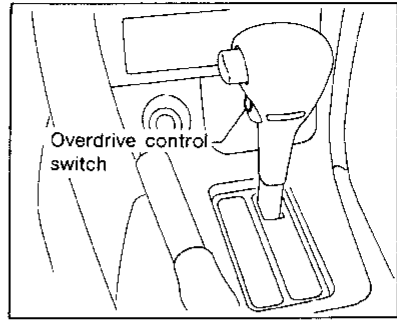
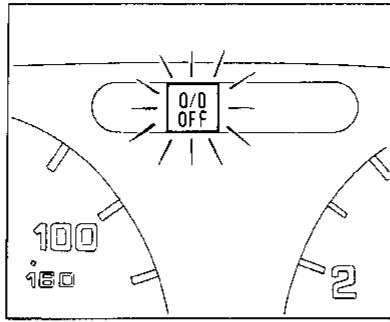
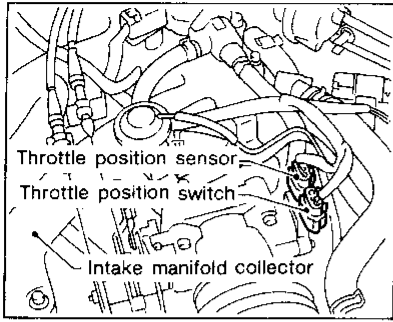

- GI
- MA
- EM
- LC
- EC
- FE
- CL
- MT
- AT**
- FA
- RA
- BR
- ST
- RS
- BT
- HA
- EL
- IDX

## Circuit Diagram for Quick Pinpoint Check

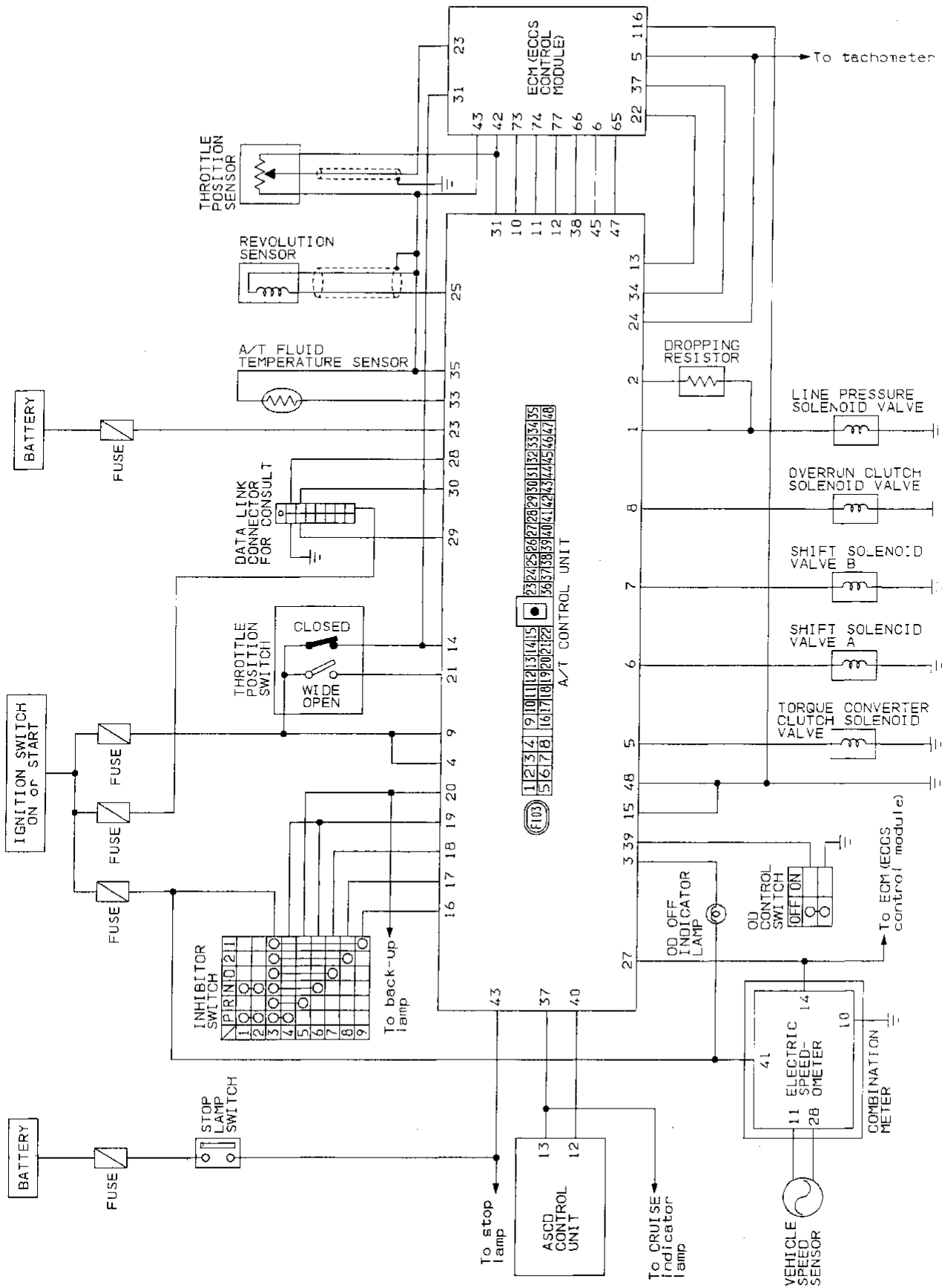

# TROUBLE DIAGNOSES

## Wiring Diagram — AT —

AT-A/T-01

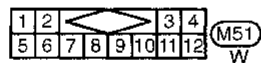
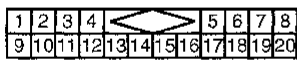
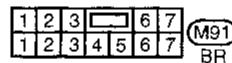
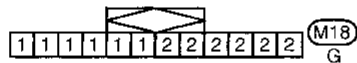
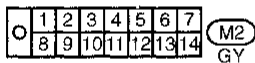
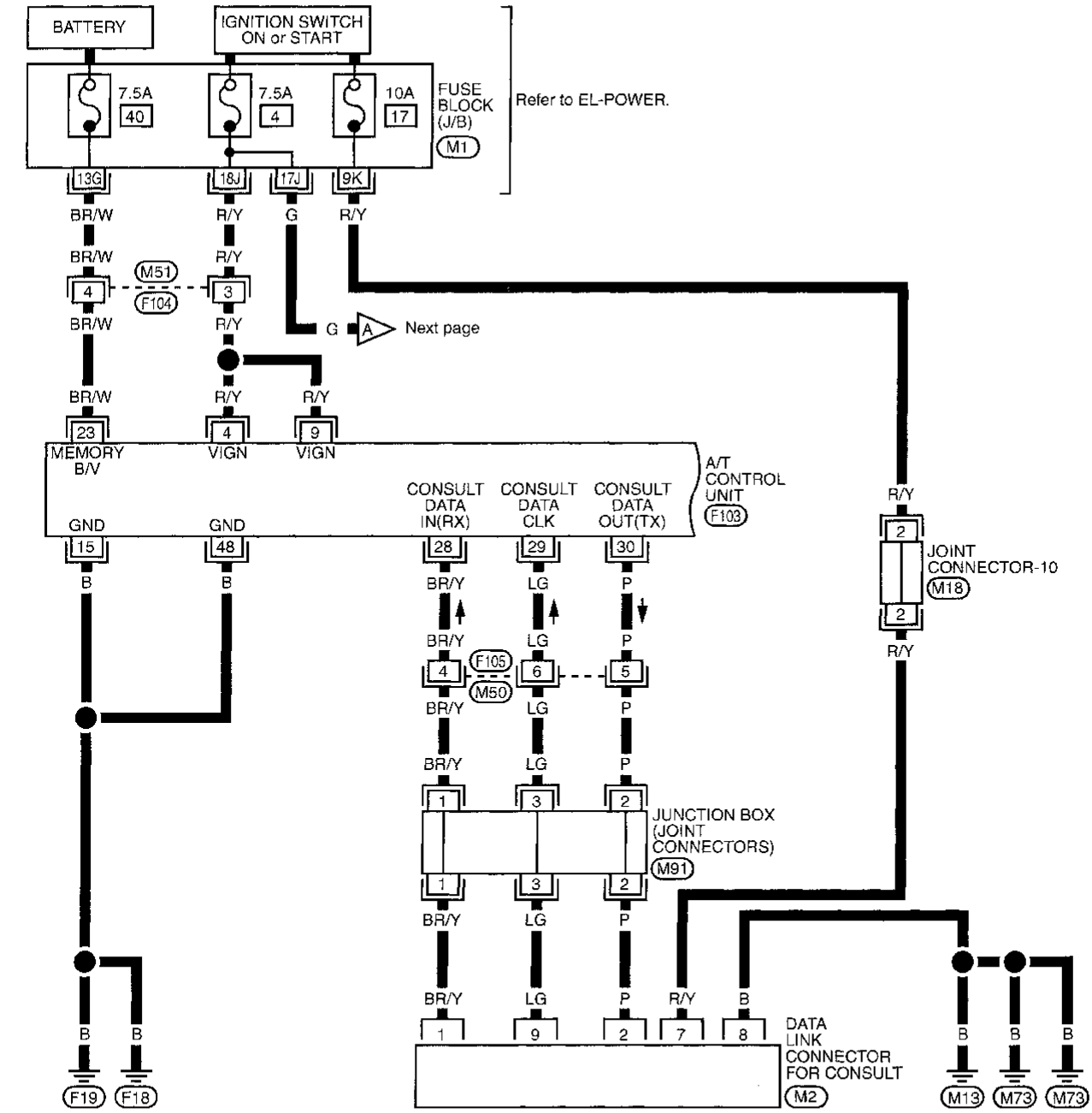

Refer to last page (Foldout page).

- (M1)
- (M18)
- (M91)
- (F103)

- GI
- MA
- EM
- LC
- EC
- FE
- CL
- WT
- AT**
- FA
- RA
- BR
- ST
- RS
- BT
- HA
- EL
- IDX

# TROUBLE DIAGNOSES

## Wiring Diagram — AT — (Cont'd)

AT-A/T-02

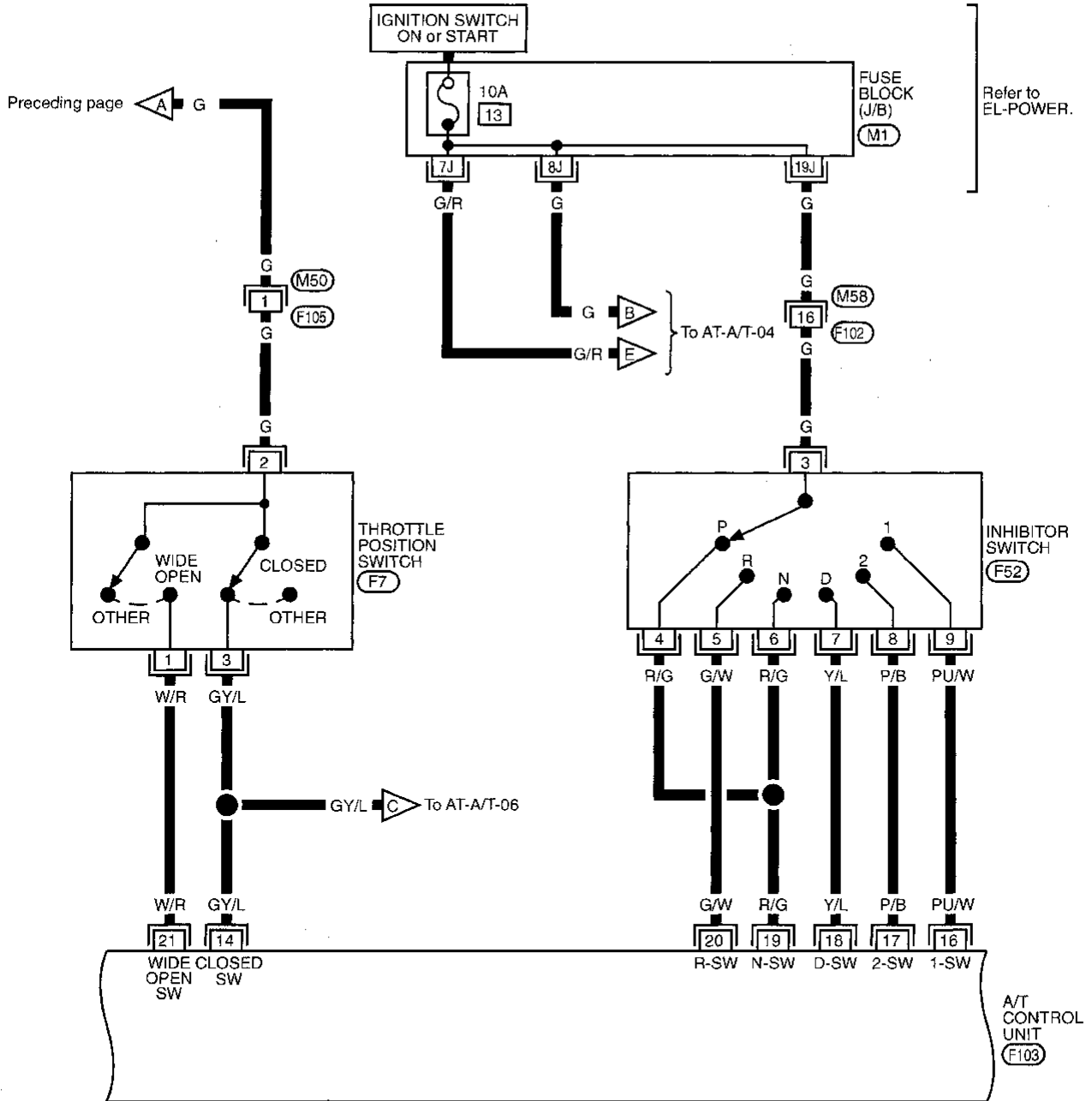

Refer to EL-POWER.

Refer to last page (Foldout page).

- (M1)
- (F103)

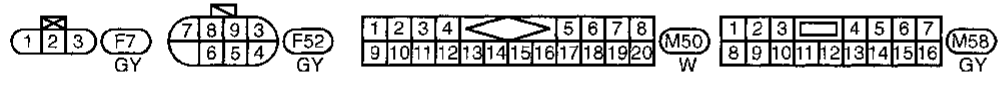



# TROUBLE DIAGNOSES

## Wiring Diagram — AT — (Cont'd)

AT-A/T-03

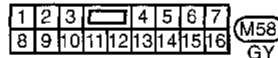
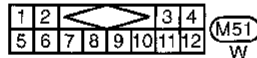
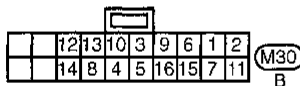
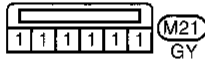
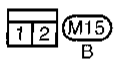
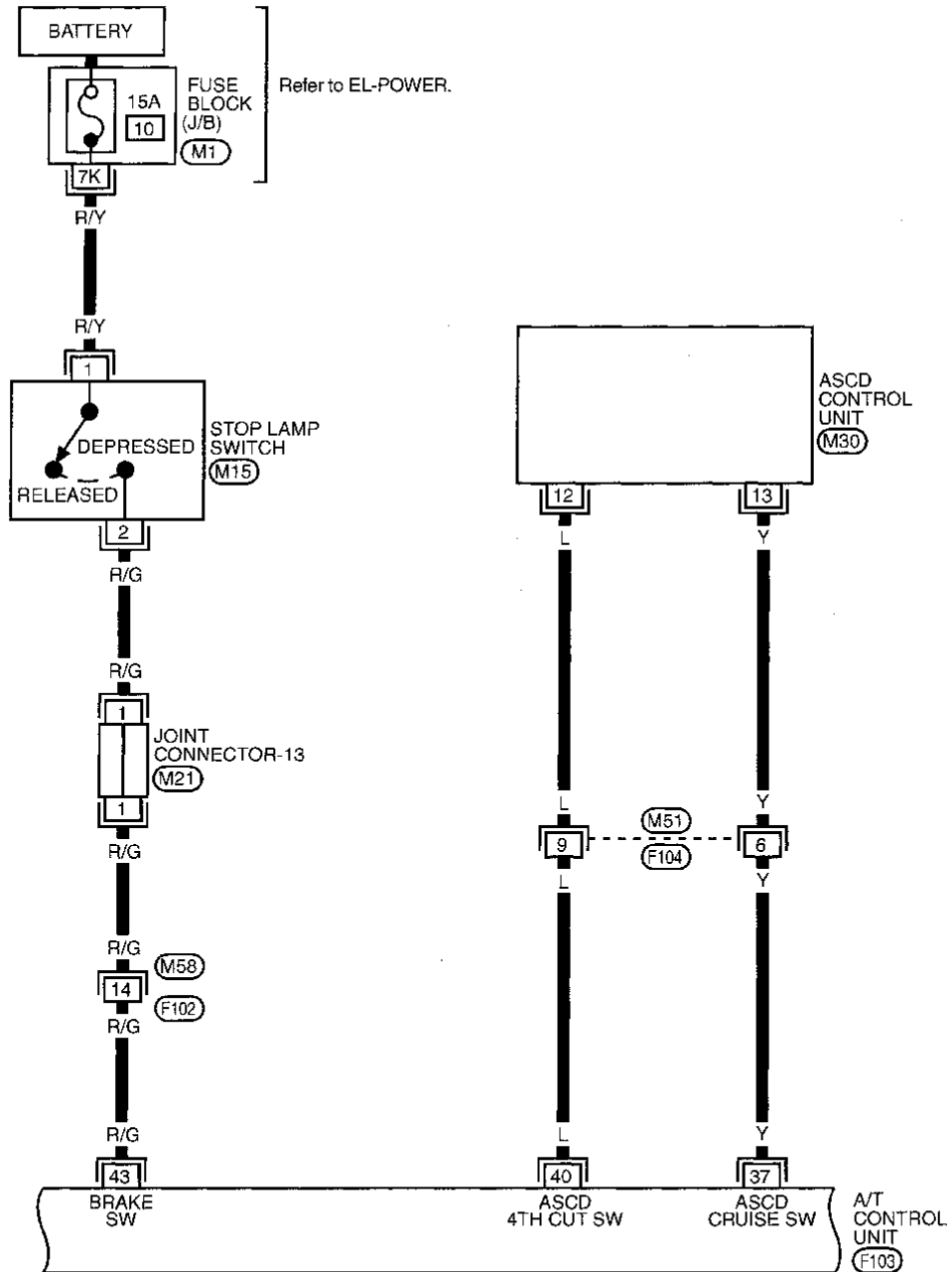

Refer to last page (Foldout page).

- (M1)
- (M21)
- (F103)

GI

MA

EM

LC

EC

FE

CL

MT

**AT**

FA

RA

BR

ST

RS

BT

HA

EL

IDX

# TROUBLE DIAGNOSES

## Wiring Diagram — AT — (Cont'd)

AT-A/T-04

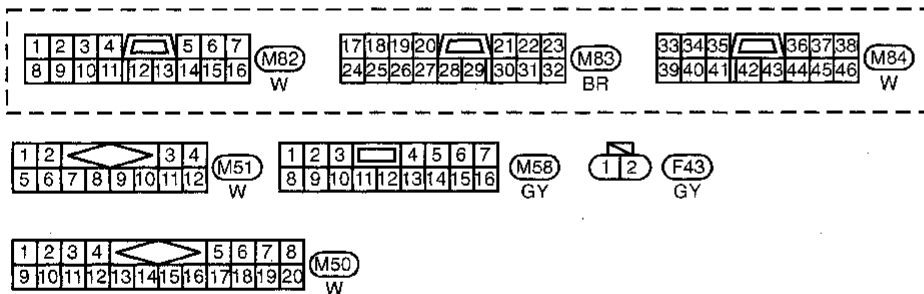
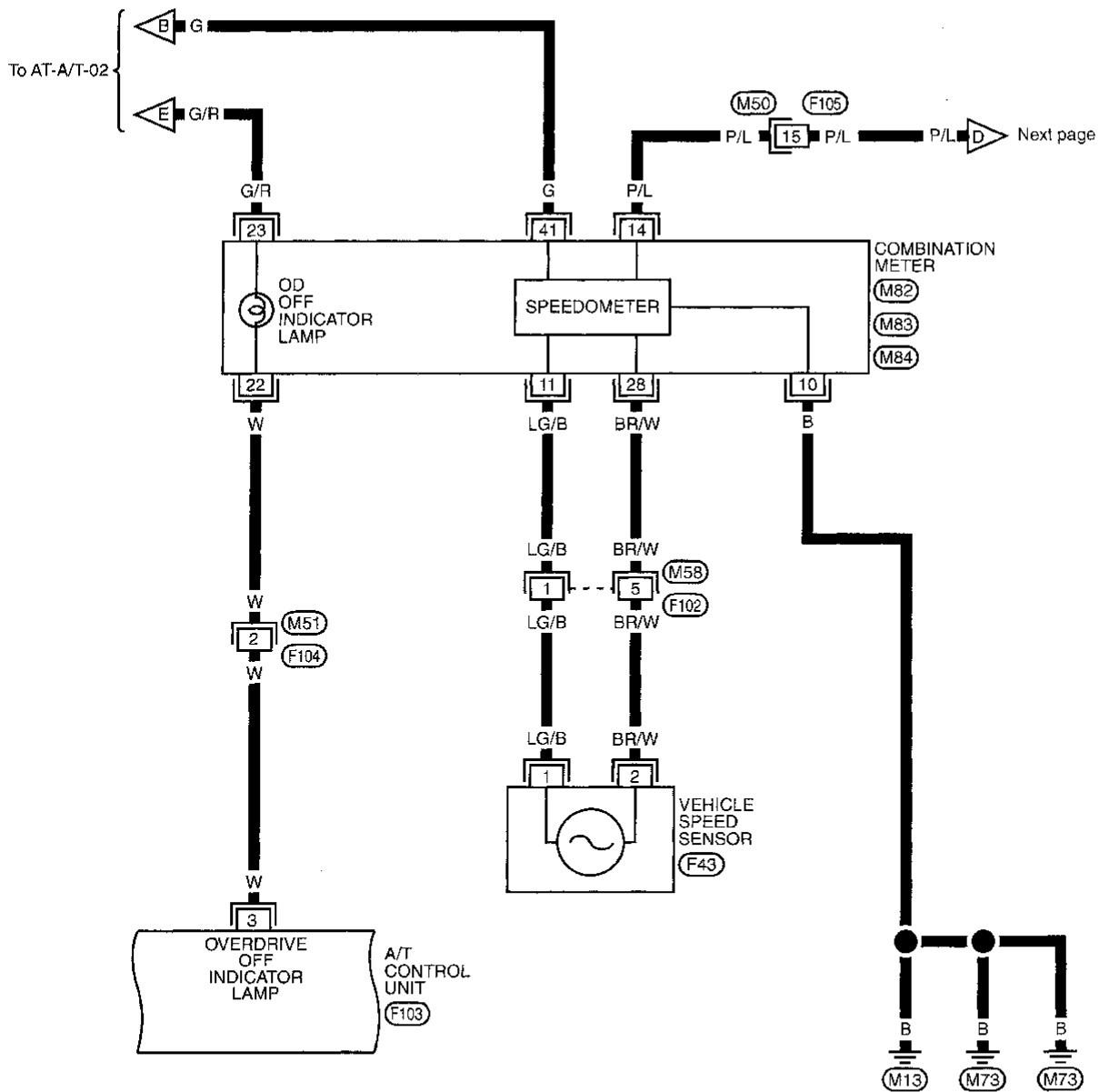

Refer to last page (Foldout page).  
F103

# TROUBLE DIAGNOSES

## Wiring Diagram — AT — (Cont'd)

AT-A/T-05

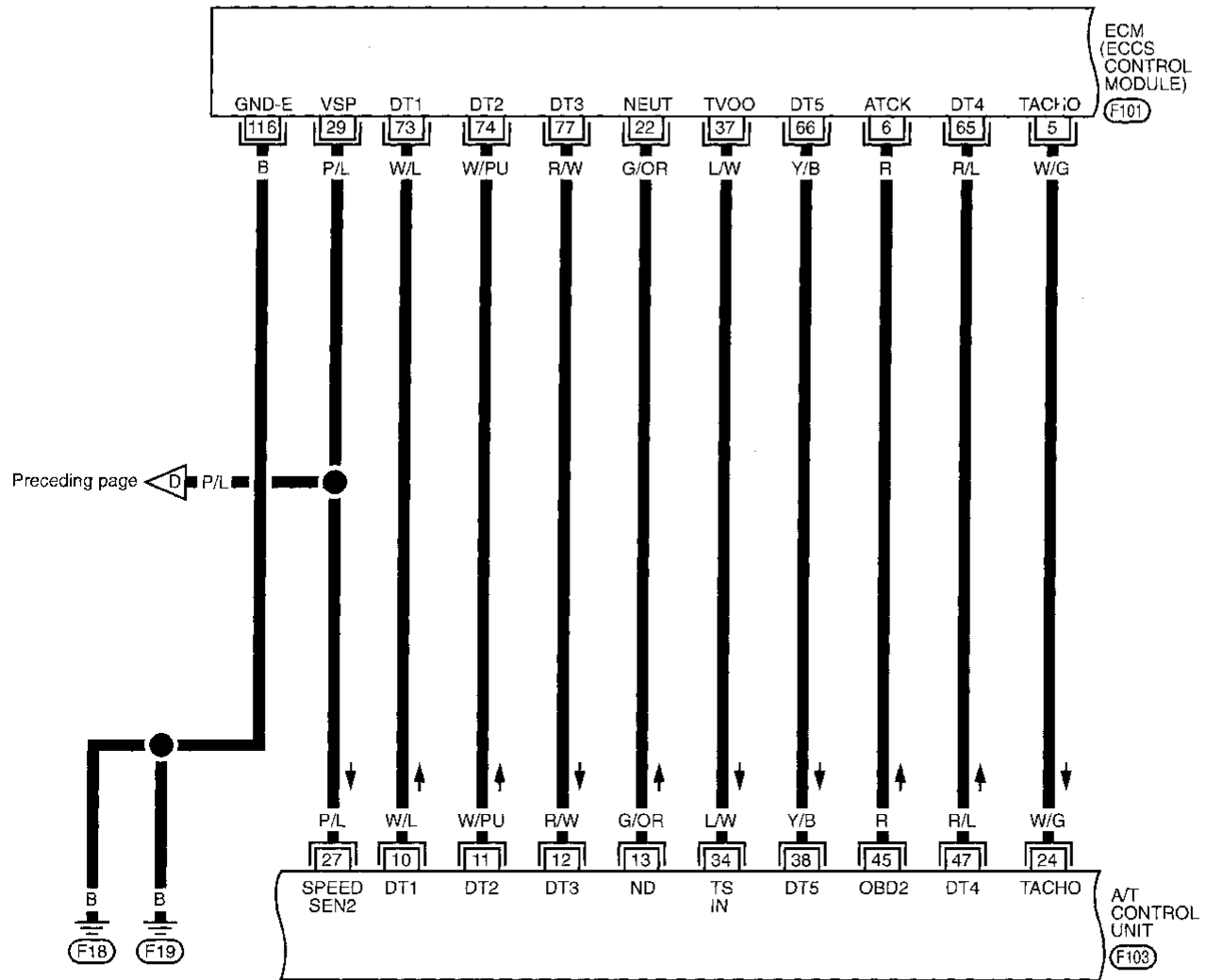

GI  
 MA  
 EM  
 LC  
 EC  
 FE  
 CL  
 MT  
**AT**  
 FA  
 RA  
 BR  
 ST  
 RS  
 BT  
 HA  
 EL  
 IDX

Refer to last page (Foldout page).

(F101)

(F103)

# TROUBLE DIAGNOSES

## Wiring Diagram — AT — (Cont'd)

AT-A/T-06

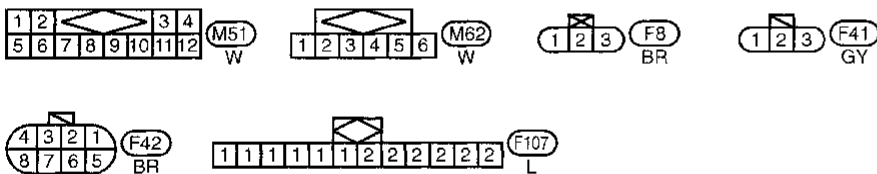
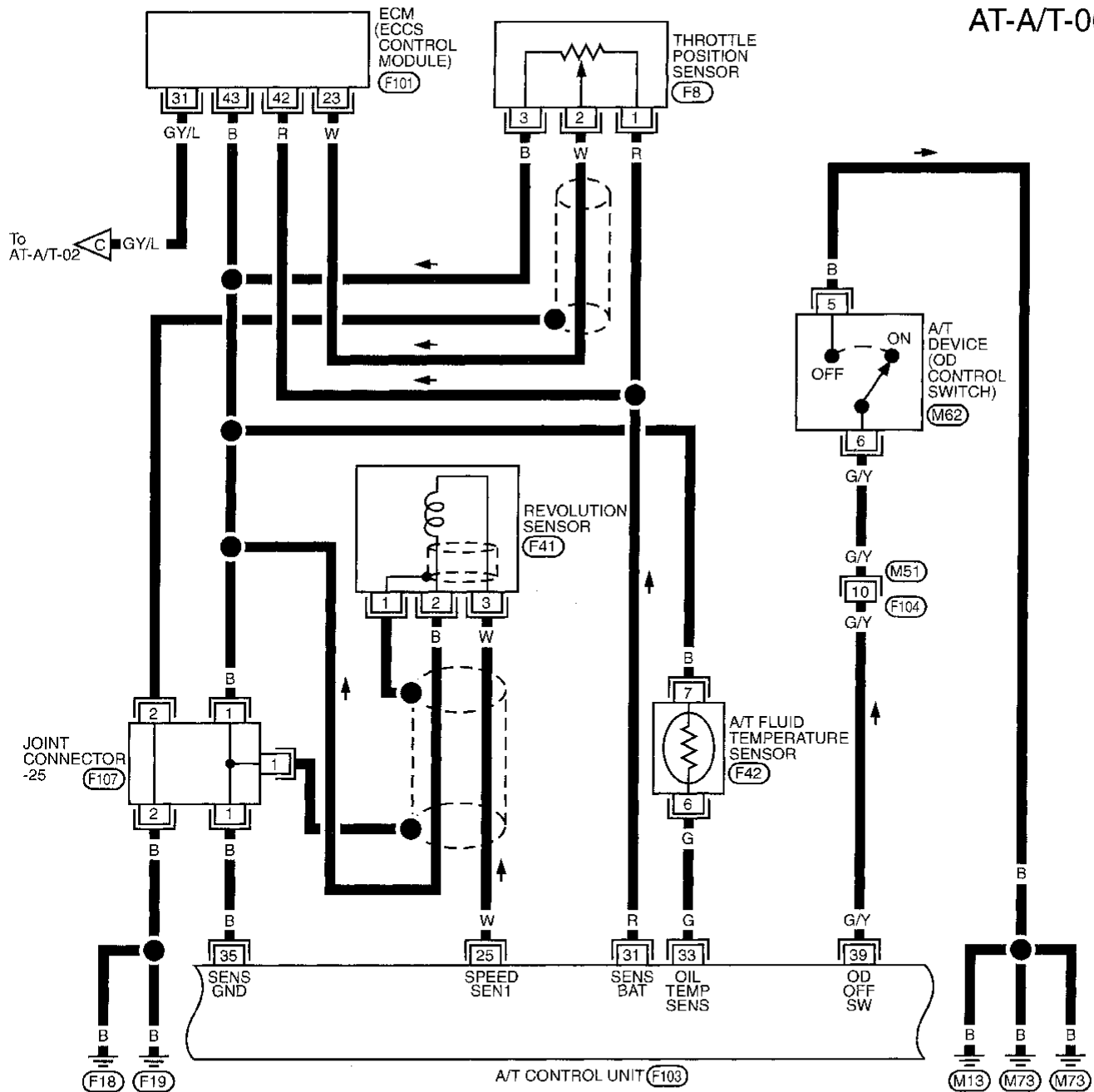

Refer to last page (Foldout page).

- (F101)
- (F103)
- (F107)

# TROUBLE DIAGNOSES

## Wiring Diagram — AT — (Cont'd)

AT-A/T-07

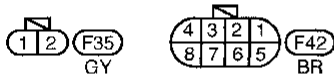
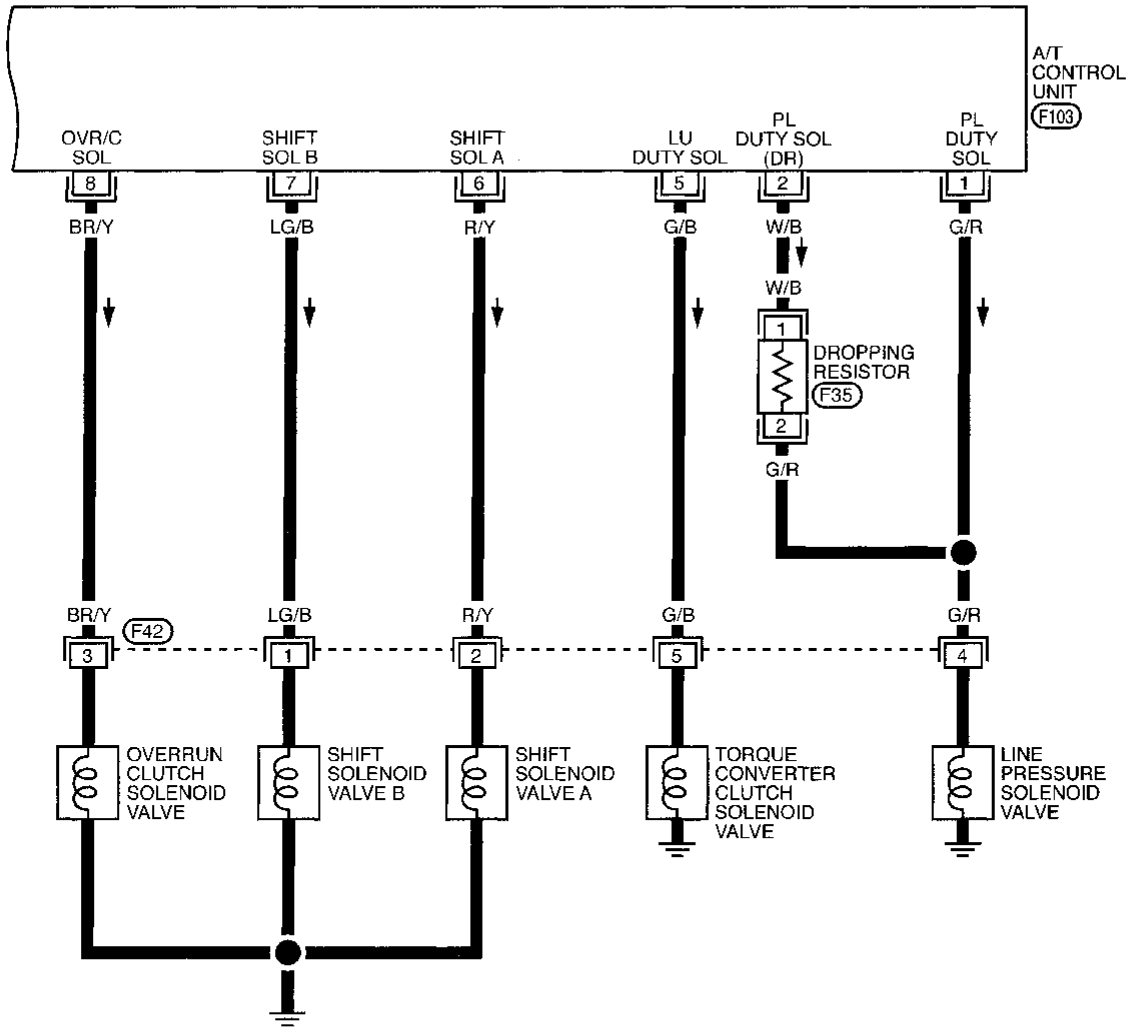

Refer to last page (Foldout page).  
F103

GI  
MA  
EM  
LC  
EC  
FE  
CL  
MT  
**AT**  
FA  
RA  
BR  
ST  
RS  
BT  
HA  
EL  
IDX

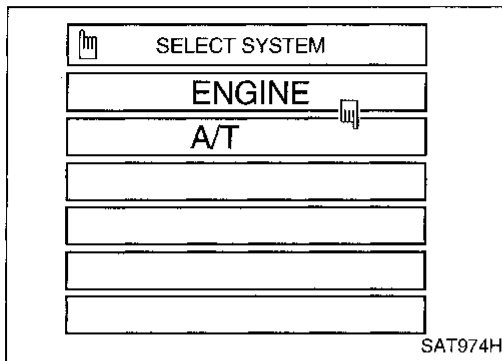

## Self-diagnosis



After performing this procedure, place check marks for results on the "DIAGNOSTIC WORKSHEET", AT-17. Reference pages are provided following the items.

### SELF-DIAGNOSTIC PROCEDURE WITH CONSULT

1. Turn on CONSULT and touch "A/T".  
If A/T is not displayed, check A/T control unit power supply and ground circuit. Refer to AT-102. If result is NG, refer to EL section ("POWER SUPPLY ROUTING").

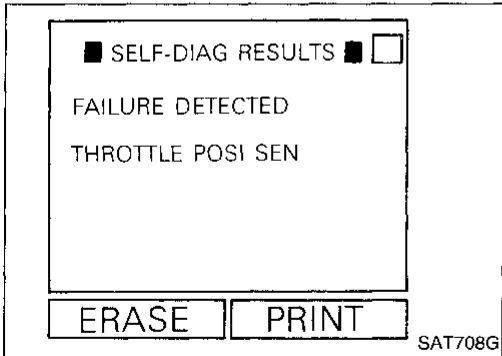

2. Touch "SELF-DIAG RESULTS".  
Display shows malfunction experienced since the last erasing operation.  
CONSULT performs REAL-TIME SELF-DIAGNOSIS.  
Also, any malfunction detected while in this mode will be displayed at real time.



Detected items (Screen terms for CONSULT, "SELF-DIAG RESULTS" mode)	Malfunction is detected when ...	Indicator for Diagnostic Results	
		 OD OFF indicator lamp (Available when "A/ T" on CONSULT is touched.)	 Malfunction indicator lamp*2 (Available when "ENGINE" on CON- SULT is touched.)
Inhibitor switch circuit (INHIBITOR SWITCH)	• A/T control unit does not receive the correct voltage signal (based on the gear position) from the switch.	—	X
Revolution sensor (VHCL SPEED SEN-A/T)	• A/T control unit does not receive the proper voltage signal from the sensor.	X	X
Vehicle speed sensor (Meter) (VHCL SPEED SEN-MTR)	• A/T control unit does not receive the proper voltage signal from the sensor.	X	—
Improper shifting to 1st gear position (A/T 1ST SIGNAL)	• A/T cannot be shifted to the 1st gear position even when electrical circuit is good.	—	X*1
Improper shifting to 2nd gear position (A/T 2ND SIGNAL)	• A/T cannot be shifted to the 2nd gear position even when electrical circuit is good.	—	X*1
Improper shifting to 3rd gear position (A/T 3RD SIGNAL)	• A/T cannot be shifted to the 3rd gear position even when electrical circuit is good.	—	X*1
Improper shifting to 4th gear position or TCC (A/T 4TH SIG OR TCC)	• A/T cannot be shifted to the 4th gear position or can not perform lock-up, even when electrical circuit is good.	—	X*1
Shift solenoid valve A (SHIFT SOLENOID/V A)	• A/T control unit detects the improper voltage drop when it tries to operate the solenoid valve.	X	X
Shift solenoid valve B (SHIFT SOLENOID/V B)	• A/T control unit detects the improper voltage drop when it tries to operate the solenoid valve.	X	X
Overrun clutch solenoid valve (OVERRUN CLUTCH S/V)	• A/T control unit detects the improper voltage drop when it tries to operate the solenoid valve.	X	X
T/C clutch solenoid valve (TOR CONV CLUTCH SV)	• A/T control unit detects the improper voltage drop when it tries to operate the solenoid valve.	X	X
Line pressure solenoid valve (LINE PRESSURE S/V)	• A/T control unit detects the improper voltage drop when it tries to operate the solenoid valve.	X	X
Throttle position sensor (THRTL POSI SEN-A/T)	• A/T control unit receives an excessively low or high voltage from the sensor.	X	X
Engine speed signal (ENGINE SPEED SIG)	• A/T control unit does not receive the proper voltage signal from the ECM.	X	X



# TROUBLE DIAGNOSES

## Self-diagnosis (Cont'd)

Detected items (Screen terms for CONSULT, "SELF-DIAG RESULTS" mode)	Malfunction is detected when ...	Indicator for Diagnostic Results	
		 OD OFF indicator lamp (Available when "A/T" on CONSULT is touched.)	 Malfunction indicator lamp*2 (Available when "ENGINE" on CONSULT is touched.)
Fluid temperature sensor (FLUID TEMP SENSOR)	• A/T control unit receives an excessively low or high voltage from the sensor.	X	X
Initial start INITIAL START	• This is not a malfunction message (Whenever shutting off a power supply to the control unit, this message appears on the screen.)	X	—
No failure (NO SELF DIAGNOSTIC FAILURE INDICATED FURTHER TESTING MAY BE REQUIRED**)	• No failure has been detected.	X	X

X : Applicable

— : Not applicable

\*1 : These malfunctions can not be displayed by MIL  if another malfunction is assigned to the OD OFF lamp .

\*2 : Refer to EC section ["Malfunction Indicator Lamp (MIL)", "ON-BOARD DIAGNOSTIC SYSTEM DESCRIPTION"].

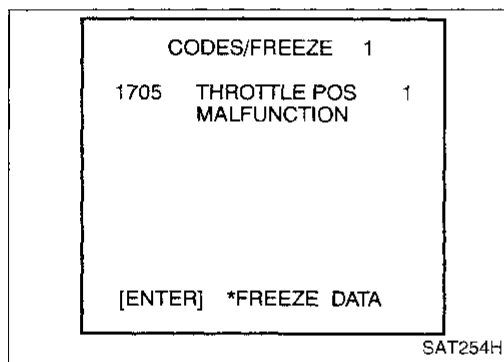

### SELF-DIAGNOSTIC PROCEDURE WITH GENERIC SCAN TOOL (GST)

Refer to EC section ["Generic Scan Tool (GST)", "ON-BOARD DIAGNOSTIC SYSTEM DESCRIPTION"].

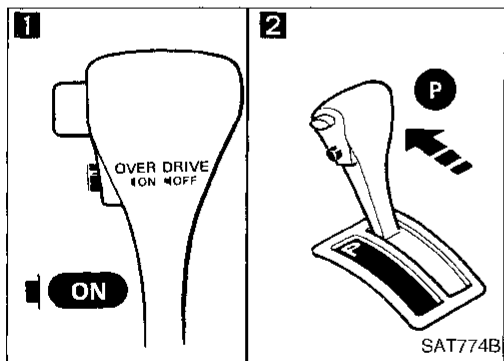

### SELF-DIAGNOSTIC PROCEDURE WITHOUT CONSULT OR GST

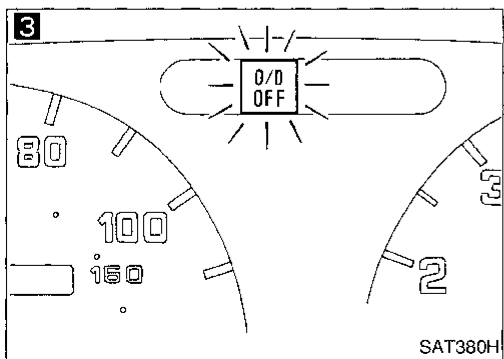
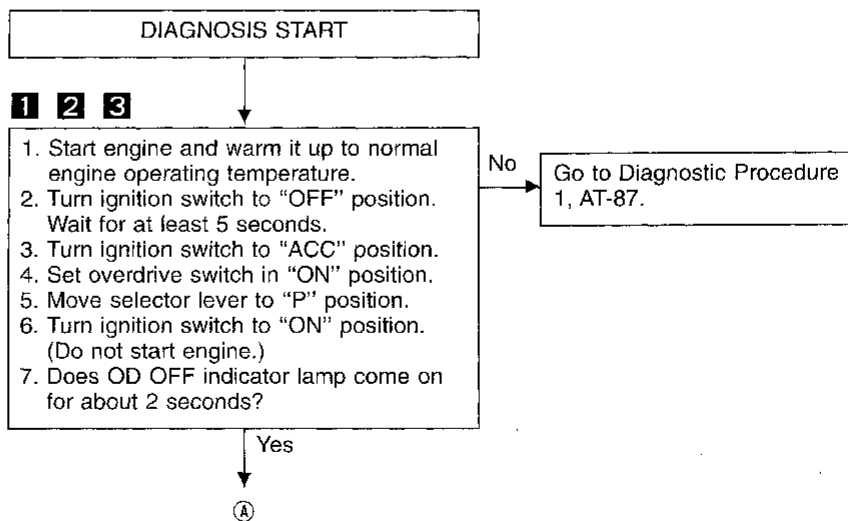

# TROUBLE DIAGNOSES

## Self-diagnosis (Cont'd)

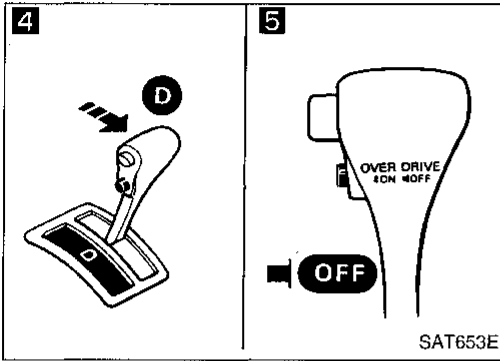

- 4 5**
1. Turn ignition switch to "OFF" position.
  2. Turn ignition switch to "ON" position.  
(Do not start engine.)
  3. Move selector lever to "D" position.
  4. Set overdrive switch to "OFF" position.
  5. Turn ignition switch to "ON" position.  
(Do not start engine.)
- Wait for more than 2 seconds after ignition switch "ON".

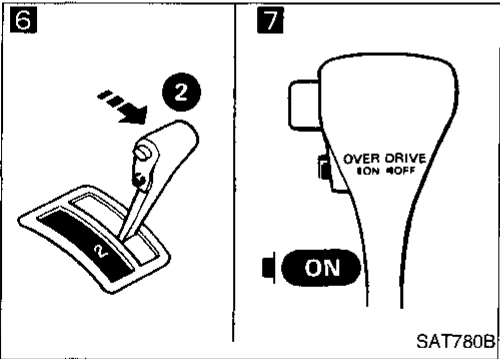

- 6 7**
1. Move selector lever to "2" position.
  2. Set overdrive switch in "ON" position.

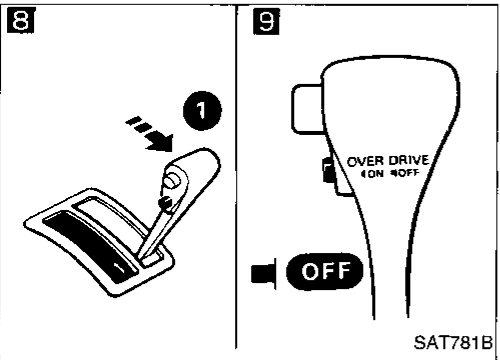

- 8 9**
- Move selector lever to "1" position.  
Set overdrive switch in "OFF" position.

- 10**
- Depress accelerator pedal fully and release it.

- 11**
- Check OD OFF indicator lamp.  
Refer to JUDGEMENT OF SELF-DIAGNOSIS CODE on next page.

DIAGNOSIS END

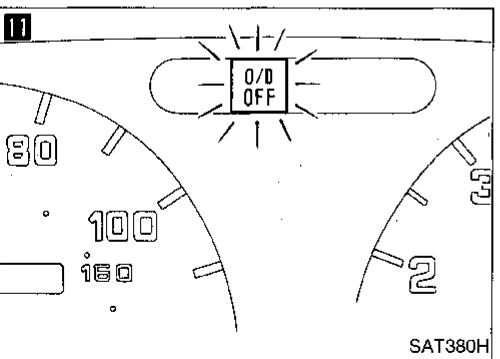
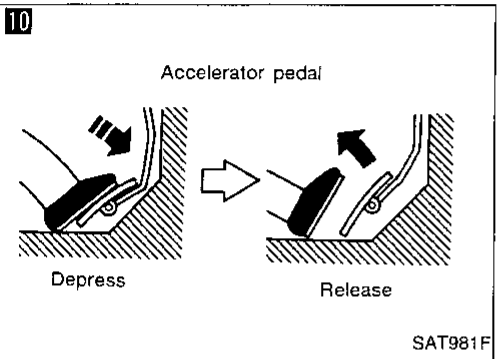



# TROUBLE DIAGNOSES

## Self-diagnosis (Cont'd)

### JUDGEMENT OF SELF-DIAGNOSIS CODE

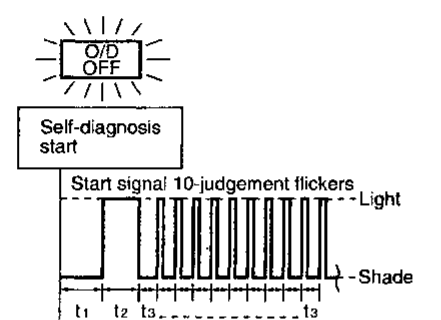
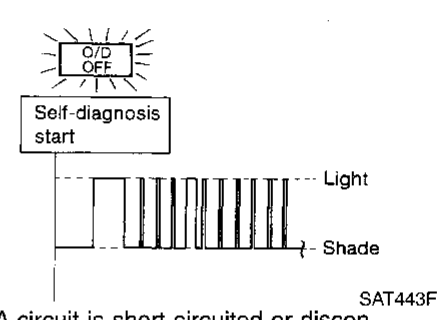
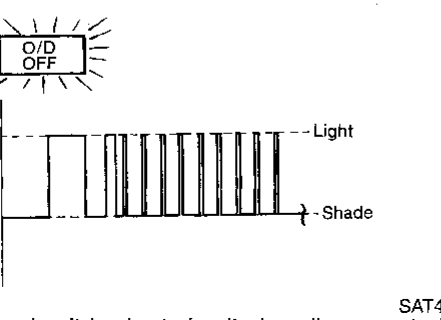
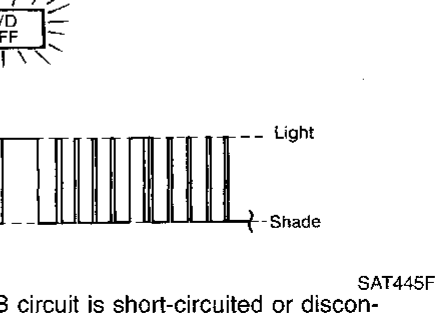
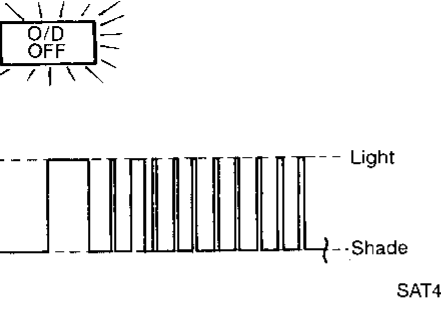
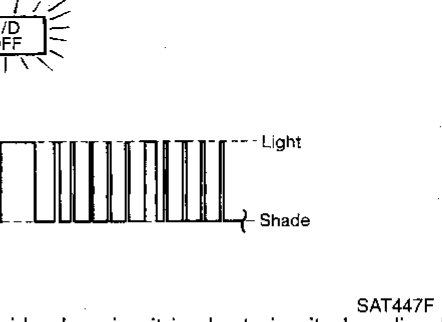
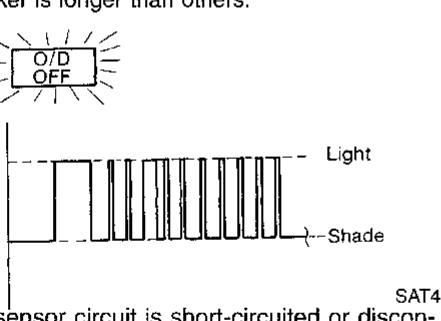
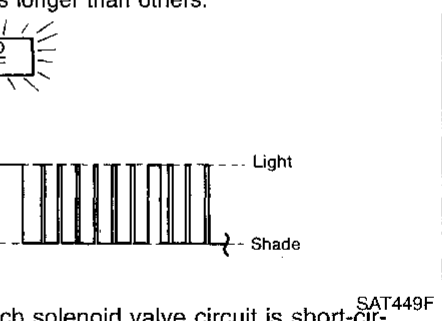
OD OFF indicator lamp:	
<p>All judgement flickers are same.</p>  <p style="text-align: right;">SAT929H</p> <p>All circuits that can be confirmed by self-diagnosis are OK.</p>	<p>4th judgement flicker is longer than others.</p>  <p style="text-align: right;">SAT443F</p> <p>Shift solenoid valve A circuit is short-circuited or disconnected.  <b>➡ Go to SHIFT SOLENOID VALVE A CIRCUIT CHECK, AT-58.</b></p>
<p>1st judgement flicker is longer than others.</p>  <p style="text-align: right;">SAT437F</p> <p>Revolution sensor circuit is short-circuited or disconnected.  <b>➡ Go to REVOLUTION SENSOR CIRCUIT CHECK, AT-52.</b></p>	<p>5th judgement flicker is longer than others.</p>  <p style="text-align: right;">SAT445F</p> <p>Shift solenoid valve B circuit is short-circuited or disconnected.  <b>➡ Go to SHIFT SOLENOID VALVE B CIRCUIT CHECK, AT-60.</b></p>
<p>2nd judgement flicker is longer than others.</p>  <p style="text-align: right;">SAT439F</p> <p>Vehicle speed sensor circuit is short-circuited or disconnected.  <b>➡ Go to VEHICLE SPEED SENSOR CIRCUIT CHECK, AT-54.</b></p>	<p>6th judgement flicker is longer than others.</p>  <p style="text-align: right;">SAT447F</p> <p>Overrun clutch solenoid valve circuit is short-circuited or disconnected.  <b>➡ Go to OVERRUN CLUTCH SOLENOID VALVE CIRCUIT CHECK, AT-62.</b></p>
<p>3rd judgement flicker is longer than others.</p>  <p style="text-align: right;">SAT441F</p> <p>Throttle position sensor circuit is short-circuited or disconnected.  <b>➡ Go to THROTTLE POSITION SENSOR CIRCUIT CHECK, AT-56.</b></p>	<p>7th judgement flicker is longer than others.</p>  <p style="text-align: right;">SAT449F</p> <p>Torque converter clutch solenoid valve circuit is short-circuited or disconnected.  <b>➡ Go to TORQUE CONVERTER CLUTCH SOLENOID VALVE CIRCUIT CHECK, AT-64.</b></p>

t<sub>1</sub> = 2.5 seconds    t<sub>2</sub> = 2.0 seconds    t<sub>3</sub> = 1.0 second

GI  
 MA  
 EM  
 LC  
 EC  
 FE  
 CL  
 MT  
**AT**  
 FA  
 RA  
 BR  
 ST  
 RS  
 BT  
 HA  
 EL  
 IDX

# TROUBLE DIAGNOSES

## Self-diagnosis (Cont'd)

OD OFF indicator lamp:

8th judgement flicker is longer than others.

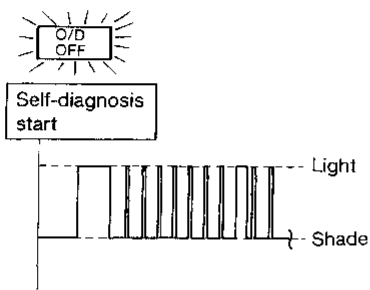

SAT451F

A/T fluid temperature sensor is disconnected or A/T control unit power source circuit is damaged.

➔ Go to **A/T FLUID TEMPERATURE SENSOR AND A/T CONTROL UNIT POWER SOURCE CIRCUIT CHECKS, AT-66.**

Flickers as shown below.

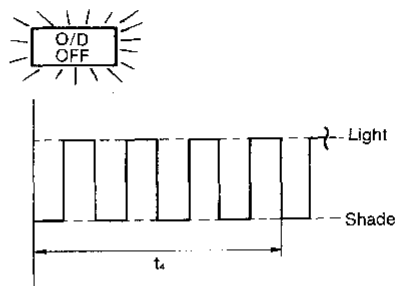

SAT457F

Battery power is low.

Battery has been disconnected for a long time.

Battery is connected conversely.

(When reconnecting A/T control unit connectors. — This is not a problem.)

9th judgement flicker is longer than others.

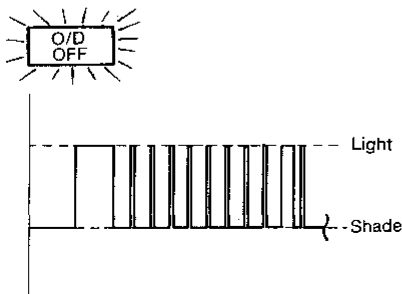

SAT453F

Engine speed signal circuit is short-circuited or disconnected.

➔ Go to **ENGINE SPEED SIGNAL CIRCUIT CHECK, AT-69.**

Does not come on.

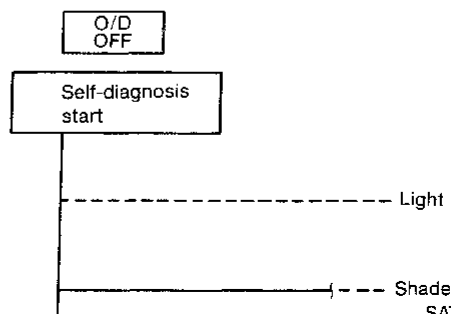

SAT458F

Inhibitor switch, overdrive switch or throttle position switch circuit is disconnected or A/T control unit is damaged.

➔ Go to **INHIBITOR, OVERDRIVE AND THROTTLE POSITION SWITCH CIRCUIT CHECKS, AT-73.**

10th judgement flicker is longer than others.

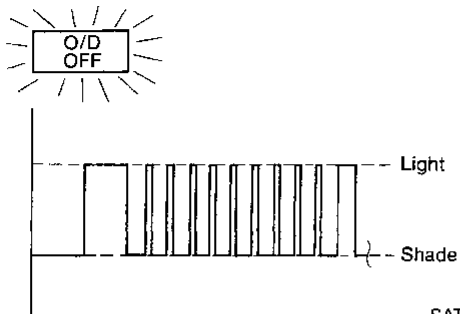

SAT455F

Line pressure solenoid valve circuit is short-circuited or disconnected.

➔ Go to **LINE PRESSURE SOLENOID VALVE CIRCUIT CHECK, AT-71.**

$t_4 = 1.0$  second

# TROUBLE DIAGNOSES

## Self-diagnosis (Cont'd)



### HOW TO ERASE DTC WITH CONSULT

1. If the ignition switch stays "ON" after repair work, be sure to turn ignition switch "OFF" once. Wait for at least 5 seconds and then turn it "ON" again.
2. Turn CONSULT "ON", and touch "A/T".
3. Touch "SELF-DIAG RESULTS".
4. Touch "ERASE". (The DTC in the A/T control unit will be erased.) And touch "BACK" twice.
5. Touch "ENGINE".
6. Touch "SELF-DIAG RESULTS".
7. Touch "ERASE". (The DTC in the ECM will be erased.)

#### How to erase DTC (With CONSULT)

1. If the ignition switch stays "ON" after repair work, be sure to turn ignition switch "OFF" once. Wait for at least 5 seconds and then turn it "ON" again.

SELECT SYSTEM
ENGINE
A/T

2. Turn CONSULT "ON", and touch "A/T".

SELECT DIAG MODE
SELF-DIAG RESULTS
DATA MONITOR
ECU PART NUMBER

3. Touch "SELF-DIAG RESULTS".

SELF-DIAG RESULTS
FAILURE DETECTED
SHIFT SOLENOID/V A
ERASE
PRINT

4. Touch "ERASE". (The DTC in the A/T control unit will be erased.)

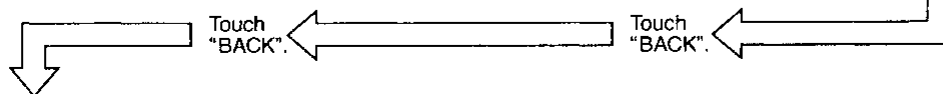

SELECT SYSTEM
ENGINE
A/T

5. Touch "ENGINE".

SELECT DIAG MODE
WORK SUPPORT
SELF-DIAG RESULTS
DATA MONITOR
ACTIVE TEST
FUNCTION TEST
FREEZE FRAME DATA

6. Touch "SELF-DIAG RESULTS".

SELF-DIAG RESULTS
FAILURE DETECTED
SHIFT SOLENOID/V A
[P0750]
ERASE
PRINT

7. Touch "ERASE". (The DTC in the ECM will be erased.)

SEF338Q



### HOW TO ERASE DTC WITH GENERIC SCAN TOOL

Select Mode 4 with Generic Scan Tool. For details, refer to EC section, "Generic Scan Tool (GST)", "ON-BOARD DIAGNOSTIC SYSTEM DESCRIPTION".



### HOW TO ERASE DTC WITHOUT CONSULT OR GST

1. If the ignition switch stays "ON" after repair work, be sure to turn ignition switch "OFF" once. Wait for at least 5 seconds and then turn it "ON" again.
2. Perform "SELF-DIAGNOSTIC PROCEDURE WITHOUT CONSULT OR GST" on AT-47. (The engine warm-up step can be skipped when performing the diagnosis only to erase the DTC.)
3. Change the diagnostic test mode from Mode II to Mode I by turning the mode selector on the ECM. Refer to EC section ["HOW TO SWITCH DIAGNOSTIC TEST MODES", "Malfunction Indicator Lamp (MIL)", "ON-BOARD DIAGNOSTIC SYSTEM DESCRIPTION"].

# TROUBLE DIAGNOSES

## Self-diagnosis (Cont'd)

### VEHICLE SPEED SENSOR-A/T (REVOLUTION SENSOR) CIRCUIT CHECK

#### Parts description

The revolution sensor detects the revolution of the idler gear parking pawl lock gear and emits a pulse signal. The pulse signal is sent to the A/T control unit which converts it into vehicle speed.

#### Trouble judgement conditions

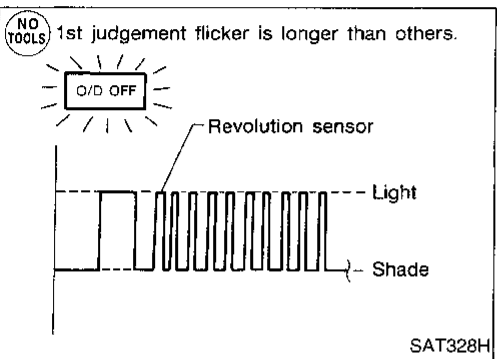
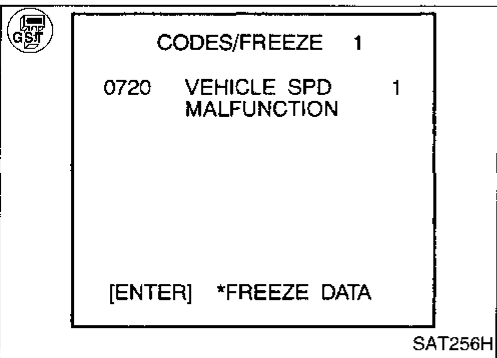
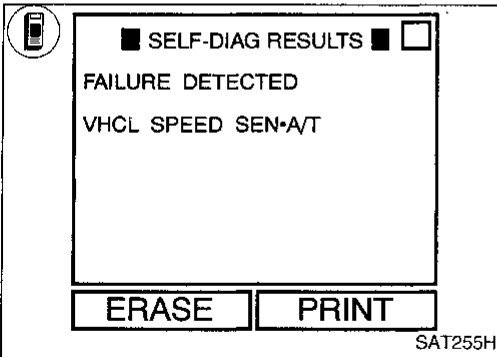
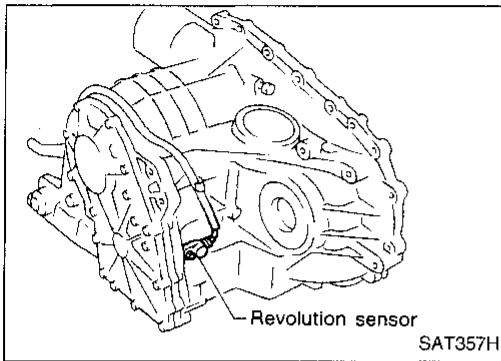

Diagnostic Trouble Code	Malfunction is detected when ...	Check Items (Possible Cause)
(CONSULT) VHCL SPEED SEN-A/T (GST) P0720 (NO TOOLS) 1st judgement flicker	• A/T control unit does not receive the proper voltage signal from the sensor.	• Harness or connectors (The sensor circuit is open or short.) • Revolution sensor

#### Diagnostic trouble code confirmation procedure

- Start engine.
  - Select "SELF-DIAG RESULTS" mode with CONSULT.
  - Drive vehicle under the following conditions:  
Selector lever in D, vehicle speed higher than 30 km/h (19 MPH), throttle opening greater than 1/8 of the full throttle position and driving for more than 5 seconds.
- OR
- Start engine.
  - Drive vehicle under the following conditions:  
Selector lever in D, vehicle speed higher than 30 km/h (19 MPH), throttle opening greater than 1/8 of the full throttle position and driving for more than 5 seconds.
  - Select "MODE 3" with GST.
- OR
- Start engine.
  - Drive vehicle under the following conditions:  
Selector lever in D, vehicle speed higher than 30 km/h (19 MPH), throttle opening greater than 1/8 of the full throttle position and driving for more than 5 seconds.
  - Perform self-diagnosis.  
Refer to SELF-DIAGNOSIS PROCEDURE WITHOUT CONSULT OR GST, AT-47.

# TROUBLE DIAGNOSES

## Self-diagnosis (Cont'd)

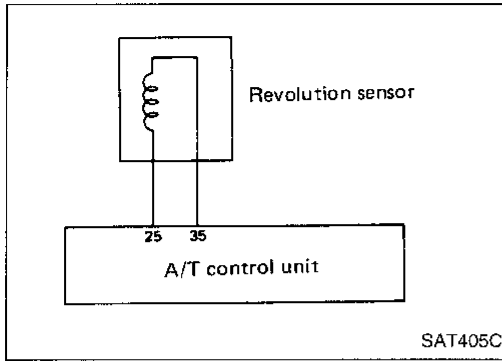

**A**

☆ MONITOR	☆ NO FAIL	
VHCL/S SE-A/T	0km/h	
VHCL/S SE-MTR	5km/h	
THRTL POS SEN	0.4V	
FLUID TEMP SE	1.2V	
BATTERY VOLT	13.4V	
ENGINE SPEED	1024rpm	
OVERDRIVE SW	O N	
P/N POSI SW	O N	
R POSITION SW	OFF	

**RECORD**

SAT076H

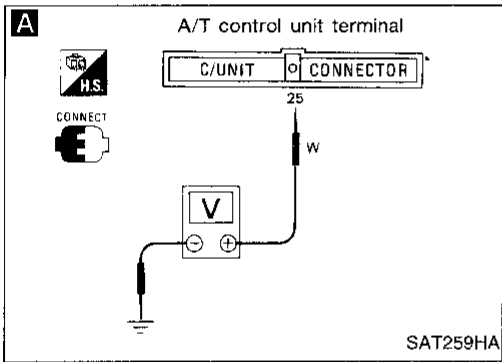

### CHECK REVOLUTION SENSOR.

Refer to "Electrical Components Inspection", AT-108.

NG

Repair or replace revolution sensor.

OK

**A**

### CHECK INPUT SIGNAL.

1. Start engine.
2. Select "ECU INPUT SIGNALS" in Data Monitor.
3. Read out the value of "VHCL/S SE-A/T" while driving. Check the value changes according to driving speed.

NG

Check the following items:

- Harness for short or open between A/T control unit and revolution sensor (Main harness)
- Harness for short or open between revolution sensor and ECM (Main harness)

OR

1. Start engine.
2. Check voltage between A/T control unit terminal 25 and ground while driving. (Measure with AC position.)

#### Voltage:

At 0 km/h (0 MPH):

0V

At 30 km/h (19 MPH):

1V or more

(Voltage rises gradually in response to vehicle speed.)

OK

Perform self-diagnosis again after driving for a while.

NG

1. Perform A/T control unit input/output signal inspection.

2. If NG, recheck A/T control unit pin terminals for damage or loose connection with harness connector.

OK

**INSPECTION END**

GI

MA

EM

LC

EC

FE

CL

MT

**AT**

FA

RA

BR

ST

RS

BT

HA

EL

IDX

# TROUBLE DIAGNOSES

## Self-diagnosis (Cont'd)

### VEHICLE SPEED SENSOR-MTR CIRCUIT CHECK

#### Parts description

The vehicle speed sensor-MTR is built into the speedometer assembly. The sensor functions as an auxiliary device to the revolution sensor when it is malfunctioning. The A/T control unit will then use a signal sent from the vehicle speed sensor-MTR.

#### Trouble judgement conditions

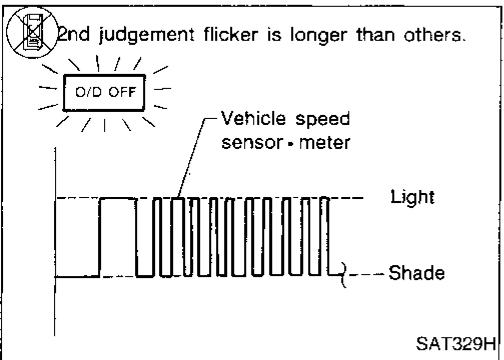
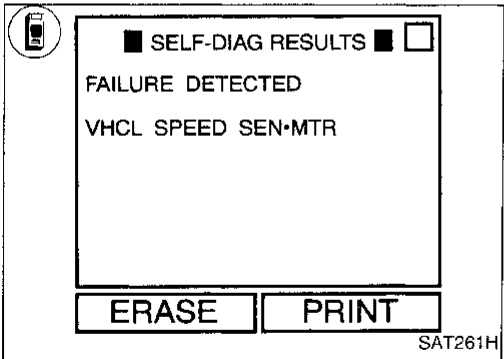
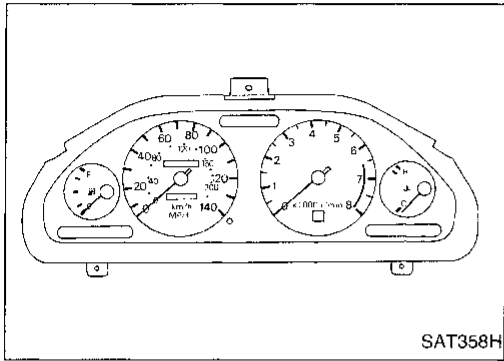

Diagnostic Trouble Code	Malfunction is detected when ...	Check Items (Possible Cause)
 VHCL SPEED SEN-MTR  2nd judgement flicker	<ul style="list-style-type: none"> <li>A/T control unit does not receive the proper voltage signal from the sensor.</li> </ul>	<ul style="list-style-type: none"> <li>Harness or connectors (The sensor circuit is open or short.)</li> <li>Vehicle speed sensor</li> </ul>

#### Diagnostic trouble code confirmation procedure

- 1) Start engine.
  - 2) Select "SELF-DIAG RESULTS" mode with CONSULT.
  - 3) Drive vehicle under the following conditions: Selector lever in D and vehicle speed higher than 20 km/h (12 MPH).
- OR
- 1) Start engine.
  - 2) Drive vehicle under the following conditions: Selector lever in D and vehicle speed higher than 20 km/h (12 MPH).
  - 3) Perform self-diagnosis. Refer to SELF-DIAGNOSIS PROCEDURE WITHOUT CONSULT OR GST, AT-47.

# TROUBLE DIAGNOSES

## Self-diagnosis (Cont'd)

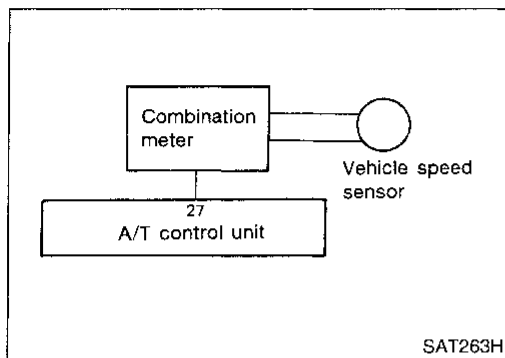

**A**

☆MONITOR	☆NO FAIL	
VHCL/S SE·A/T	0km/h	
VHCL/S SE·MTR	5km/h	
THRTL POS SEN	0.4V	
FLUID TEMP SE	1.2V	
BATTERY VOLT	13.4V	
ENGINE SPEED	1024rpm	
OVERDRIVE SW	O N	
P/N POSI SW	O N	
R POSITION SW	OFF	

**RECORD**

SAT076H

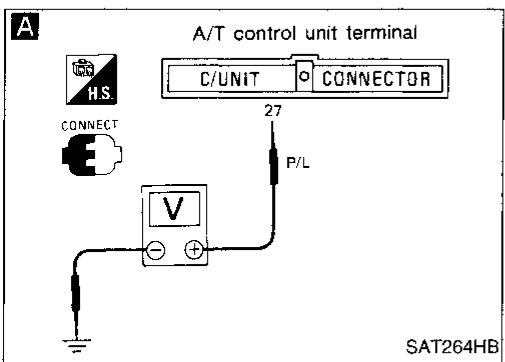

**A**

**CHECK INPUT SIGNAL.**

- Start engine.
- Select "ECU INPUT SIGNALS" in Data Monitor.
- Read out the value of "VHCL/S SE·MTR" while driving. Check the value changes according to driving speed.

OR

- Start engine.
- Check voltage between A/T control unit terminal ② and ground while driving at 2 to 3 km/h (1 to 2 MPH) for 1 m (3 ft) or more.

**Voltage:**  
Varies from 0V to 5V

**NG** → Check the following items:

- Vehicle speed sensor and ground circuit for vehicle speed sensor Refer to EL section ("METERS AND GAUGES").
- Harness for short or open between A/T control unit and vehicle speed sensor (Main harness)

**OK** → Perform self-diagnosis again after driving for a while.

**NG** →

- Perform A/T control unit input/output signal inspection.
- If NG, recheck A/T control unit pin terminals for damage or loose connection with harness connector.

**INSPECTION END**

GI  
MA  
EM  
LC  
EC  
FE  
CL  
MT  
AT  
FA  
RA  
BR  
ST  
RS  
BT  
HA  
EL  
IDX

# TROUBLE DIAGNOSES

## Self-diagnosis (Cont'd)



### THROTTLE POSITION SENSOR CIRCUIT CHECK

#### Parts description

The throttle position sensor detects the throttle valve position and sends a signal to the A/T control unit.

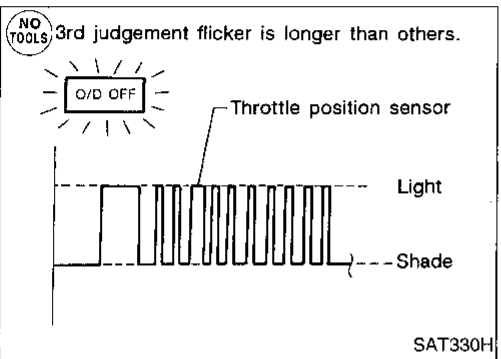
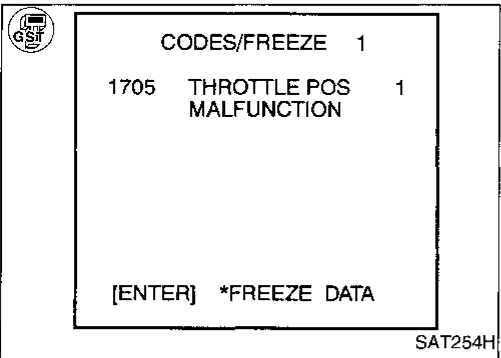
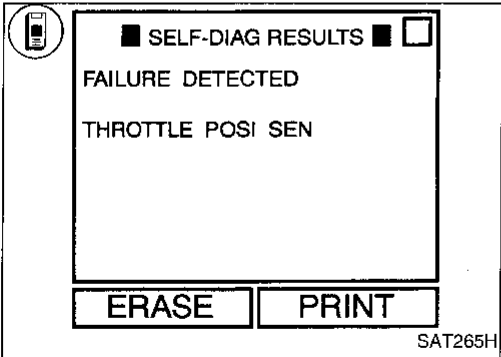
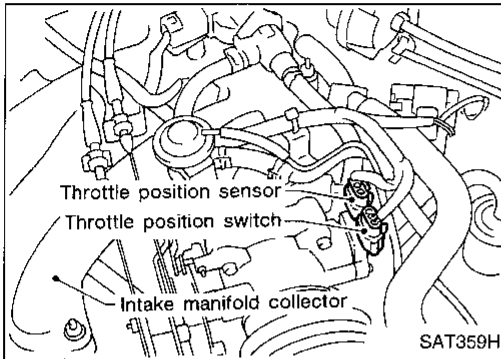
#### Trouble judgement conditions



Diagnostic Trouble Code	Malfunction is detected when ...	Check Items (Possible Cause)
 THROTTLE POSI SEN   P1705   3rd judgement flicker	<ul style="list-style-type: none"> <li>A/T control unit receives an excessively low or high voltage from the sensor.</li> </ul>	<ul style="list-style-type: none"> <li>Harness or connectors (The sensor circuit is open or short.)</li> <li>Throttle position sensor</li> </ul>

#### Diagnostic trouble code confirmation procedure

-  1) Start engine.  
 2) Select "SELF-DIAG RESULTS" mode with CONSULT.  
 3) Drive vehicle under the following conditions:  
 Selector lever in D, vehicle speed higher than 10 km/h (6 MPH), throttle opening greater than 1/2 of the full throttle position and driving for more than 3 seconds.

OR

-  1) Start engine.  
 2) Drive vehicle under the following conditions:  
 Selector lever in D, vehicle speed higher than 10 km/h (6 MPH), throttle opening greater than 1/2 of the full throttle position and driving for more than 3 seconds.  
 3) Select "MODE 3" with GST.

OR

-  1) Start engine.  
 2) Drive vehicle under the following conditions:  
 Selector lever in D, vehicle speed higher than 10 km/h (6 MPH), throttle opening greater than 1/2 of the full throttle position and driving for more than 3 seconds.  
 3) Perform self-diagnosis.  
 Refer to SELF-DIAGNOSIS PROCEDURE WITHOUT CONSULT OR GST, AT-47.



# TROUBLE DIAGNOSES

## Self-diagnosis (Cont'd)

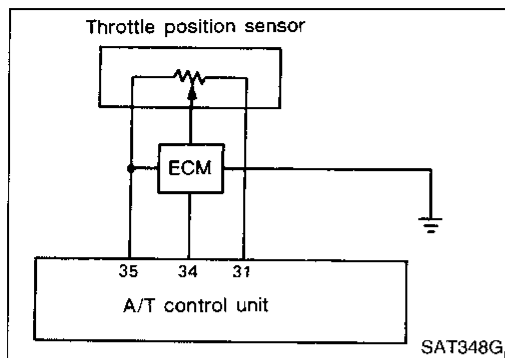

**A**

☆MONITOR	☆NO FAIL	
VHCL/S SE-A/T	0km/h	
VHCL/S SE-MTR	5km/h	
THRTL POS SEN	0.4V	
FLUID TEMP SE	1.2V	
BATTERY VOLT	13.4V	
ENGINE SPEED	1024rpm	
OVERDRIVE SW	O N	
P/N POSI SW	O N	
R POSITION SW	OFF	

**RECORD**

SAT076H

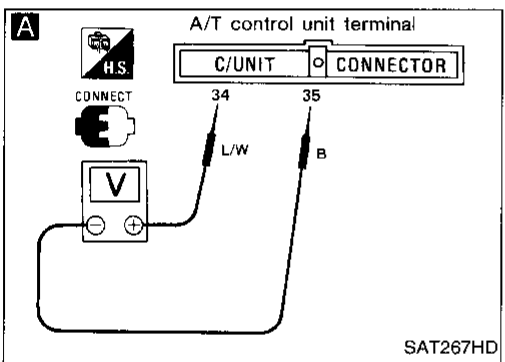

Perform diagnostic test mode II (self-diagnostic results) for engine control. Refer to EC section ["Malfunction Indicator Lamp (MIL)", "ON-BOARD DIAGNOSTIC SYSTEM DESCRIPTION"].

NG → Check throttle position sensor circuit for engine control. Refer to EC section ["Throttle Position Sensor (DTC: 0403)", "TROUBLE DIAGNOSIS FOR DTC P0120"].

OK

**A**

**CHECK INPUT SIGNAL.**

1. Turn ignition switch to "ON" position. (Do not start engine.)

2. Select "ECU INPUT SIGNALS" in Data Monitor.

3. Read out the value of "THRTL POS SEN".

**Voltage:**  
**Fully-closed throttle: Approximately 0.5V**  
**Fully-open throttle: Approximately 4V**

OR

1. Turn ignition switch to "ON" position. (Do not start engine.)

2. Check voltage between A/T control unit terminals ③ and ⑤ while accelerator pedal is depressed slowly.

**Voltage:**  
**Fully-closed throttle valve: Approximately 0.5V**  
**Fully-open throttle valve: Approximately 4V**  
**(Voltage rises gradually in response to throttle position)**

NG → Check harness for short or open between ECM and A/T control unit regarding throttle position sensor circuit. (Main harness)

OK

Perform self-diagnosis again after driving for a while.

NG → 1. Perform A/T control unit input/output signal inspection.  
2. If NG, recheck A/T control unit pin terminals for damage or loose connection with harness connector.

OK

**INSPECTION END**

GI  
MA  
EM  
LC  
EC  
FE  
CL  
MT  
AT  
FA  
RA  
BR  
ST  
RS  
BT  
HA  
EL  
IDX

# TROUBLE DIAGNOSES

## Self-diagnosis (Cont'd)

### SHIFT SOLENOID VALVE A CIRCUIT CHECK

#### Parts description

Shift solenoid valves A and B are turned ON or OFF by the A/T control unit in response to signals sent from the inhibitor switch, vehicle speed and throttle position sensors. Gears will then be shifted to the optimum position.

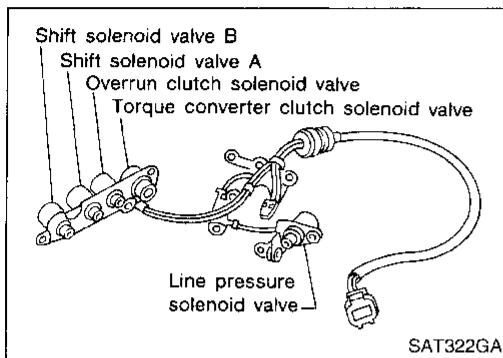

SAT322GA

Gear position	1	2	3	4
Shift solenoid valve A	ON	OFF	OFF	ON
Shift solenoid valve B	ON	ON	OFF	OFF

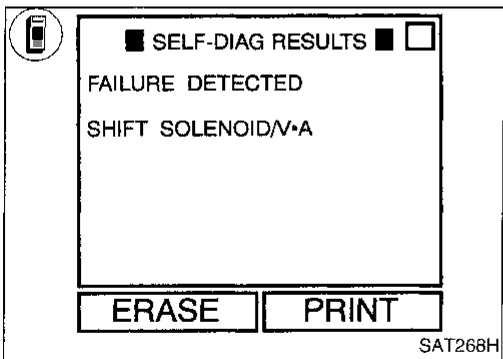

SAT268H

#### Trouble judgement conditions

Diagnostic Trouble Code	Malfunction is detected when ...	Check Items (Possible Cause)
 SHIFT SOLENOID/V·A  P0750  4th judgement flicker	<ul style="list-style-type: none"> <li>A/T control unit detects the improper voltage drop when it tries to operate the solenoid valve.</li> </ul>	<ul style="list-style-type: none"> <li>Harness or connectors (The solenoid circuit is open or short.)</li> <li>Shift solenoid valve A</li> </ul>

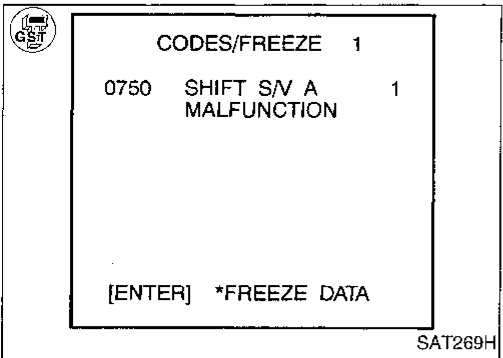

SAT269H

#### Diagnostic trouble code confirmation procedure

- 1) Start engine.  
 2) Select "SELF-DIAG RESULTS" mode with CONSULT.  
 3) Drive vehicle in D<sub>1</sub> → D<sub>2</sub> position.  
 OR
- 1) Start engine.  
 2) Drive vehicle in D<sub>1</sub> → D<sub>2</sub> position.  
 3) Select "MODE 3" with GST.  
 OR
- 1) Start engine.  
 2) Drive vehicle in D<sub>1</sub> → D<sub>2</sub> position.  
 3) Perform self-diagnosis.  
 Refer to SELF-DIAGNOSIS PROCEDURE WITHOUT CONSULT OR GST, AT-47.

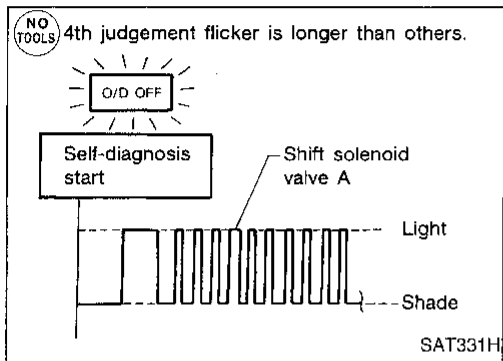

SAT331H

# TROUBLE DIAGNOSES

## Self-diagnosis (Cont'd)

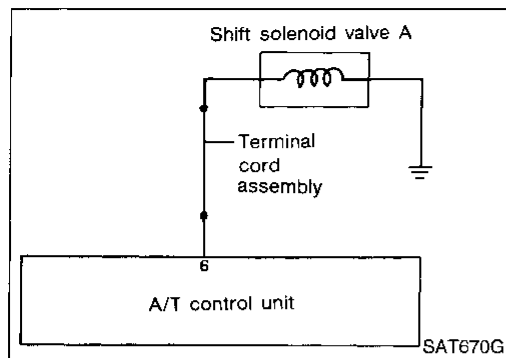

**A**

### CHECK GROUND CIRCUIT.

1. Turn ignition switch to "OFF" position.
2. Disconnect terminal cord assembly connector in engine compartment.
3. Check resistance between terminal ② and ground.

**Resistance: 20 - 30Ω**

NG

1. Remove control valve assembly. Refer to "ON-VEHICLE SERVICE", AT-124.
2. Check the following items:
  - Shift solenoid valve A (Refer to "Electrical Components Inspection", AT-106.)
  - Harness of terminal cord assembly for short or open

OK

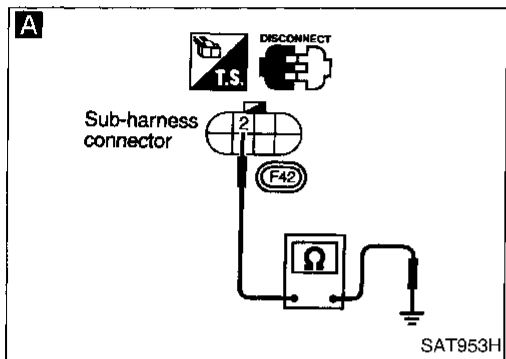

**B**

### CHECK POWER SOURCE CIRCUIT.

1. Turn ignition switch to "OFF" position.
2. Disconnect A/T control unit harness connector.
3. Check resistance between terminal ② and A/T control unit terminal ⑥.

**Resistance: Approximately 0Ω**

NG

- Repair or replace harness between A/T control unit and terminal cord assembly. (Main harness)

OK

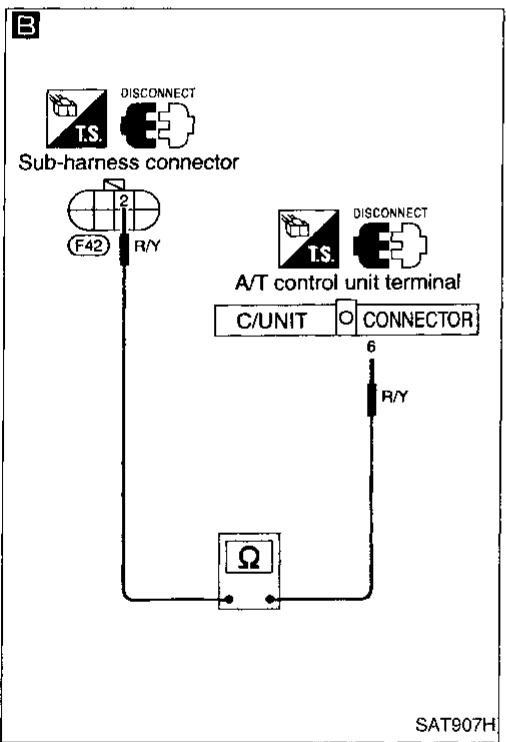

Perform self-diagnosis after driving for a while.

NG

1. Perform A/T control unit input/output signal inspection.
2. If NG, recheck A/T control unit pin terminals for damage or loose connection with harness connector.

OK

**INSPECTION END**

GI

MA

EM

LC

EC

FE

CL

MT

AT

FA

RA

BR

ST

RS

BT

HA

EL

IDX

# TROUBLE DIAGNOSES

## Self-diagnosis (Cont'd)

### SHIFT SOLENOID VALVE B CIRCUIT CHECK

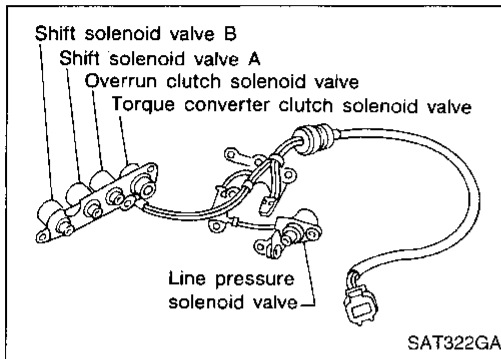

#### Parts description

Shift solenoid valves A and B are turned ON or OFF by the A/T control unit in response to signals sent from the inhibitor switch, vehicle speed and throttle position sensors. Gears will then be shifted to the optimum position.

Gear position	1	2	3	4
Shift solenoid valve A	ON	OFF	OFF	ON
Shift solenoid valve B	ON	ON	OFF	OFF

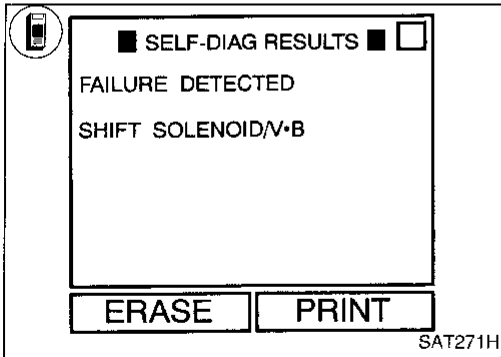

#### Trouble judgement conditions

Diagnostic Trouble Code	Malfunction is detected when ...	Check Items (Possible Cause)
 SHIFT SOLENOID/V-B  P0755  5th judgement flicker	<ul style="list-style-type: none"> <li>A/T control unit detects the improper voltage drop when it tries to operate the solenoid valve.</li> </ul>	<ul style="list-style-type: none"> <li>Harness or connectors (The solenoid circuit is open or short.)</li> <li>Shift solenoid valve B</li> </ul>

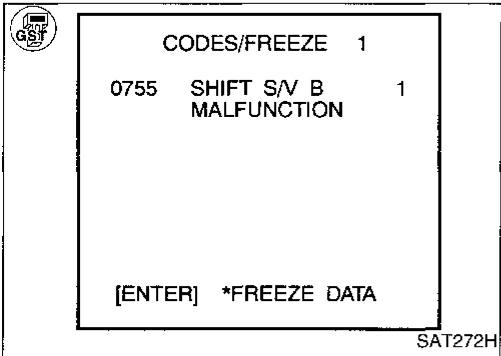

#### Diagnostic trouble code confirmation procedure

- 1) Start engine.  
 2) Select "SELF-DIAG RESULTS" mode with CONSULT.  
 3) Drive vehicle in D<sub>1</sub> → D<sub>2</sub> → D<sub>3</sub> position.
- OR

- 1) Start engine.  
 2) Drive vehicle in D<sub>1</sub> → D<sub>2</sub> → D<sub>3</sub> position.  
 3) Select "MODE 3" with GST.
- OR

- 1) Start engine.  
 2) Drive vehicle in D<sub>1</sub> → D<sub>2</sub> → D<sub>3</sub> position.  
 3) Perform self-diagnosis.  
 Refer to SELF-DIAGNOSIS PROCEDURE WITHOUT CONSULT OR GST, AT-47.

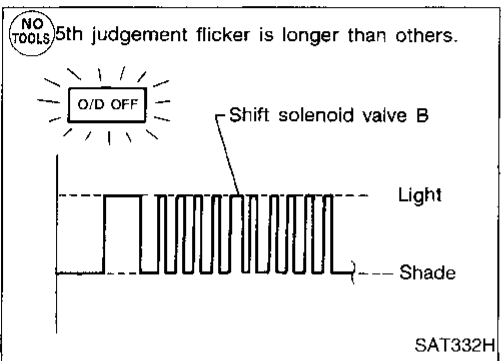

# TROUBLE DIAGNOSES

## Self-diagnosis (Cont'd)

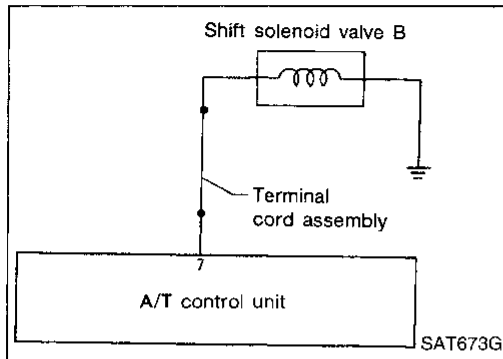

**A**

### CHECK GROUND CIRCUIT.

1. Turn ignition switch to "OFF" position.
2. Disconnect terminal cord assembly connector in engine compartment.
3. Check resistance between terminal ① and ground.

**Resistance: 20 - 30Ω**

NG

1. Remove control valve assembly. Refer to "ON-VEHICLE SERVICE", AT-124.
2. Check the following items:
  - Shift solenoid valve B (Refer to "Electrical Components Inspection", AT-106.)
  - Harness of terminal cord assembly for short or open

OK

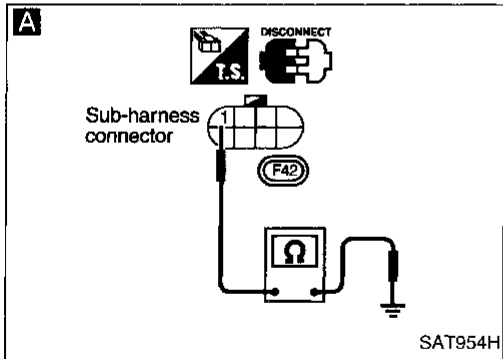

**B**

### CHECK POWER SOURCE CIRCUIT.

1. Turn ignition switch to "OFF" position.
2. Disconnect A/T control unit harness connector.
3. Check resistance between terminal ① and A/T control unit terminal ⑦.

**Resistance: Approximately 0Ω**

NG

- Repair or replace harness between A/T control unit and terminal cord assembly. (Main harness)

OK

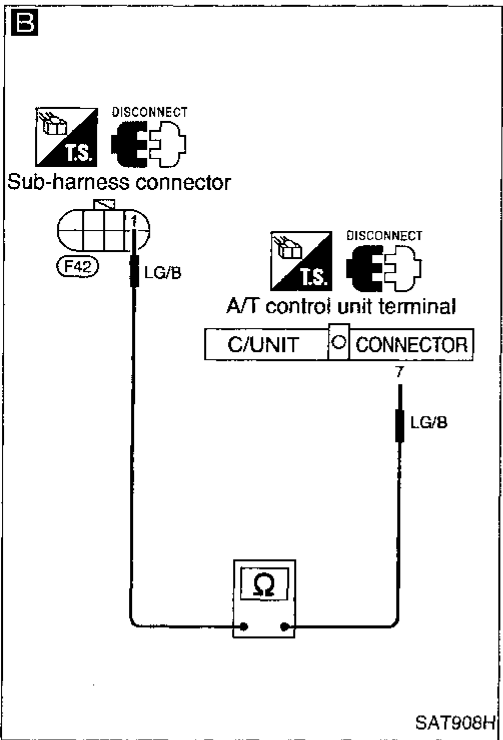

Perform self-diagnosis after driving for a while.

NG

1. Perform A/T control unit input/output signal inspection.
2. If NG, recheck A/T control unit pin terminals for damage or loose connection with harness connector.

OK

**INSPECTION END**

GI

MA

EM

LC

EC

FE

CL

MT

AT

FA

RA

BR

ST

RS

BT

HA

EL

IDX

# TROUBLE DIAGNOSES

## Self-diagnosis (Cont'd)

### OVERRUN CLUTCH SOLENOID VALVE CIRCUIT CHECK

#### Parts description

The overrun clutch solenoid valve is activated by the A/T control unit in response to signals sent from the inhibitor switch, OD switch, vehicle speed and throttle position sensors. The overrun clutch operation will then be controlled.

#### Trouble judgement conditions

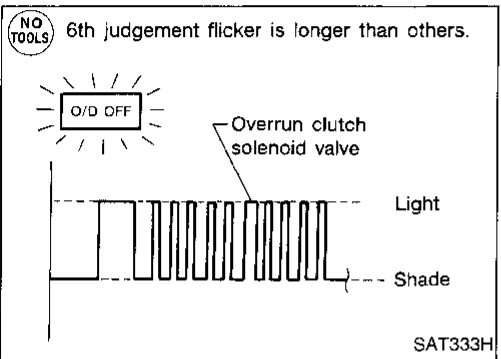
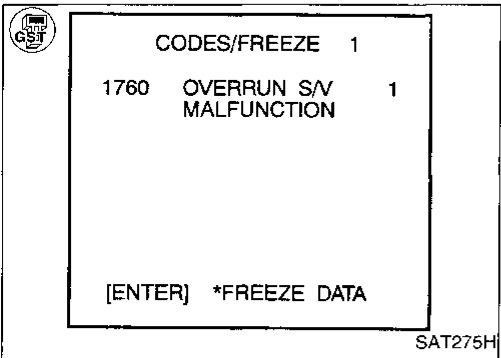
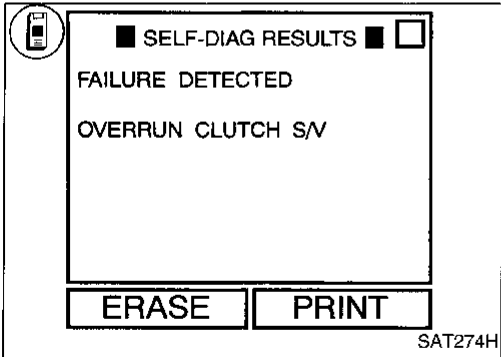
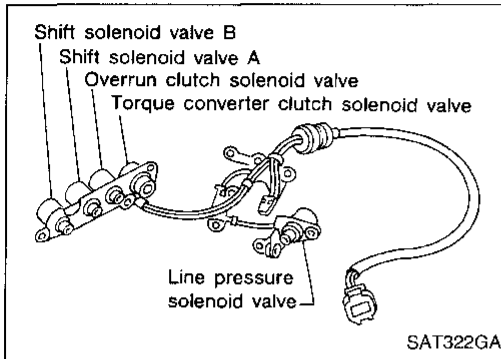

Diagnostic Trouble Code	Malfunction is detected when ...	Check Items (Possible Cause)
(CONSULT) OVERRUN CLUTCH S/V (GST) P1760 (NO TOOLS) 6th judgement flicker	• A/T control unit detects the improper voltage drop when it tries to operate the solenoid valve.	• Harness or connectors (The solenoid circuit is open or short.) • Overrun clutch solenoid valve

#### Diagnostic trouble code confirmation procedure

- (CONSULT)
- 1) Start engine.
  - 2) Select "SELF-DIAG RESULTS" mode with CONSULT.
  - 3) Drive vehicle under the following conditions:  
Selector lever in D, OD control switch in "OFF" position and vehicle speed higher than 10 km/h (6 MPH).
- OR
- (GST)
- 1) Start engine.
  - 2) Drive vehicle under the following conditions:  
Selector lever in D, OD control switch in "OFF" position and vehicle speed higher than 10 km/h (6 MPH).
  - 3) Select "MODE 3" with GST.
- OR
- (NO TOOLS)
- 1) Start engine.
  - 2) Drive vehicle under the following conditions:  
Selector lever in D, OD control switch in "OFF" position and vehicle speed higher than 10 km/h (6 MPH).
  - 3) Perform self-diagnosis.  
Refer to SELF-DIAGNOSIS PROCEDURE WITHOUT CONSULT OR GST, AT-47.

# TROUBLE DIAGNOSES

## Self-diagnosis (Cont'd)

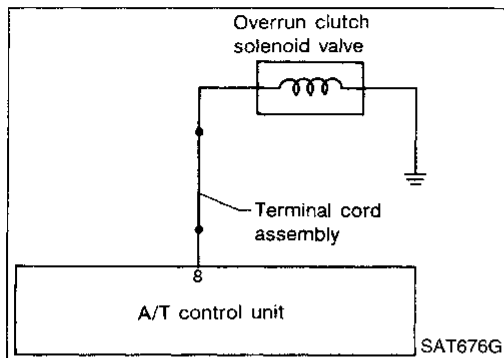

**A**

### CHECK GROUND CIRCUIT.

1. Turn ignition switch to "OFF" position.
2. Disconnect terminal cord assembly connector in engine compartment.
3. Check resistance between terminal ③ and ground.

**Resistance: 20 - 30Ω**

NG

1. Remove control valve assembly. Refer to "ON-VEHICLE SERVICE", AT-124.
2. Check the following items:
  - Overrun clutch solenoid valve (Refer to "Electrical Components Inspection", AT-106.)
  - Harness of terminal cord assembly for short or open

GI

MA

EM

LC

EC

FE

CL

MT

AT

FA

RA

BR

ST

RS

BT

HA

EL

IDX

OK

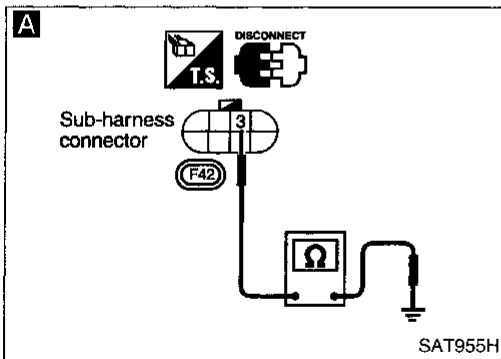

**B**

### CHECK POWER SOURCE CIRCUIT.

1. Turn ignition switch to "OFF" position.
2. Disconnect A/T control unit harness connector.
3. Check resistance between terminal ③ and A/T control unit terminal ⑧.

**Resistance: Approximately 0Ω**

NG

- Repair or replace harness between A/T control unit and terminal cord assembly. (Main harness)

OK

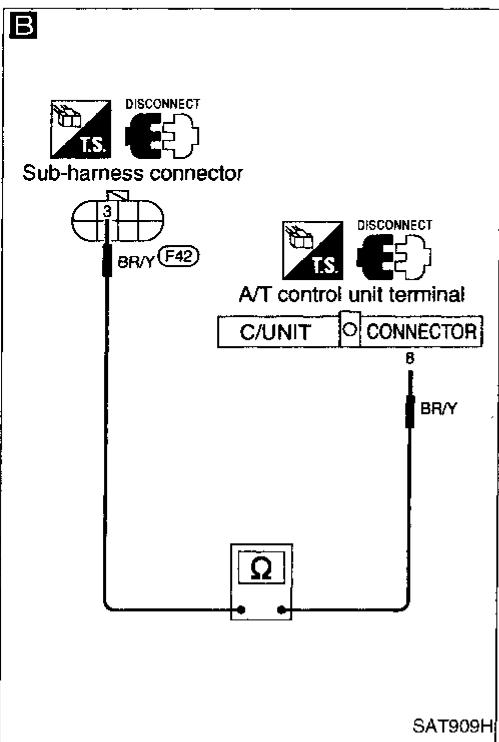

Perform self-diagnosis after driving for a while.

NG

1. Perform A/T control unit input/output signal inspection.
2. If NG, recheck A/T control unit pin terminals for damage or loose connection with harness connector.

OK

**INSPECTION END**

# TROUBLE DIAGNOSES

## Self-diagnosis (Cont'd)

### TORQUE CONVERTER CLUTCH SOLENOID VALVE CIRCUIT CHECK

#### Parts description

The torque converter clutch solenoid valve is activated, with the gear in D<sub>4</sub>, by the A/T control unit in response to signals sent from the vehicle speed and throttle position sensors. Lock-up piston operation will then be controlled.

Lock-up operation, however, is prohibited when ATF temperature is too low.

#### Trouble judgement conditions

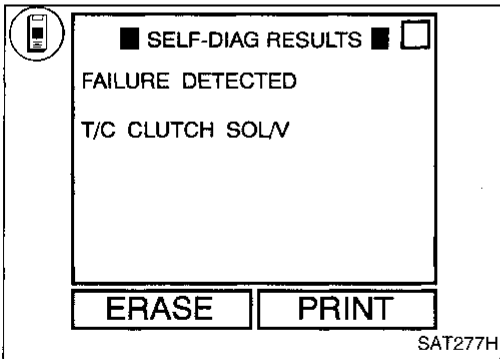
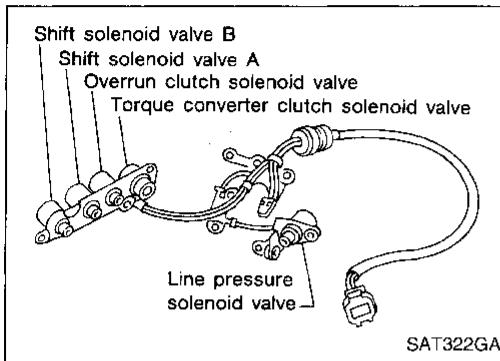

Diagnostic Trouble Code	Malfunction is detected when ...	Check Items (Possible Cause)
 T/C CLUTCH SOLV  P0740  7th judgement flicker	<ul style="list-style-type: none"> <li>A/T control unit detects the improper voltage drop when it tries to operate the solenoid valve.</li> </ul>	<ul style="list-style-type: none"> <li>Harness or connectors (The solenoid circuit is open or short.)</li> <li>T/C clutch solenoid valve</li> </ul>

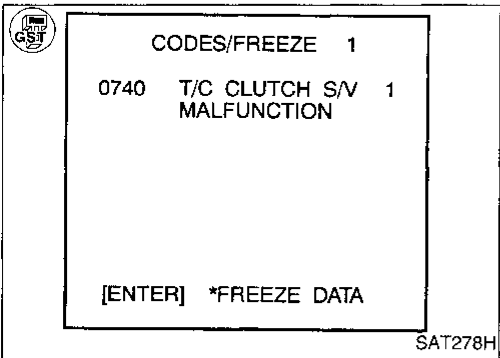

#### Diagnostic trouble code confirmation procedure

- 1) Start engine.  
 2) Select "SELF-DIAG RESULTS" mode with CONSULT.  
 3) Drive vehicle in D<sub>1</sub> → D<sub>2</sub> → D<sub>3</sub> → D<sub>4</sub> → D<sub>4</sub> lock-up position.

OR

- 1) Start engine.  
 2) Select "MODE 3" with GST.  
 3) Drive vehicle in D<sub>1</sub> → D<sub>2</sub> → D<sub>3</sub> → D<sub>4</sub> → D<sub>4</sub> lock-up position.

OR

- 1) Start engine.  
 2) Perform self-diagnosis.  
 Refer to SELF-DIAGNOSIS PROCEDURE WITHOUT CONSULT OR GST, AT-47.  
 3) Drive vehicle in D<sub>1</sub> → D<sub>2</sub> → D<sub>3</sub> → D<sub>4</sub> → D<sub>4</sub> lock-up position.

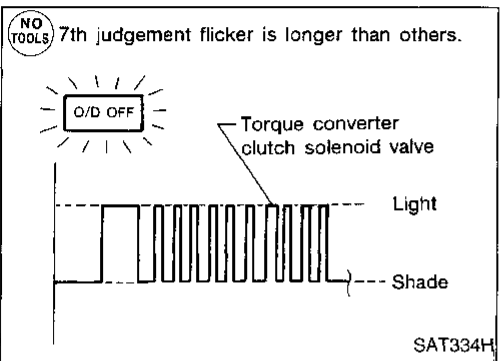



# TROUBLE DIAGNOSES

## Self-diagnosis (Cont'd)

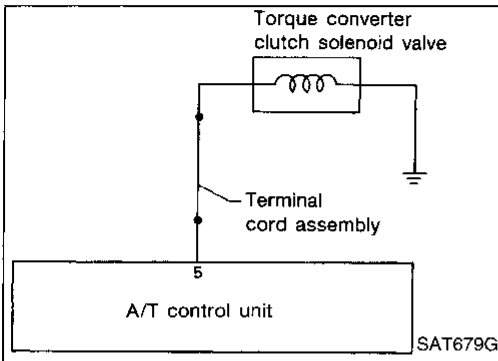

**A**

**CHECK GROUND CIRCUIT.**

1. Turn ignition switch to "OFF" position.
2. Disconnect terminal cord assembly connector in engine compartment.
3. Check resistance between terminal ⑤ and ground.

**Resistance: 10 - 16Ω**

NG →

1. Remove oil pan. Refer to "ON-VEHICLE SERVICE", AT-124.
2. Check the following items:
  - Torque converter clutch solenoid valve (Refer to "Electrical Components Inspection", AT-106.)
  - Harness of terminal cord assembly for short or open

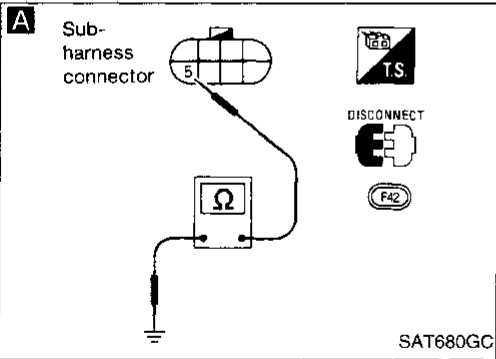

**B**

**CHECK POWER SOURCE CIRCUIT.**

1. Turn ignition switch to "OFF" position.
2. Disconnect A/T control unit harness connector.
3. Check resistance between terminal ⑤ and A/T control unit terminal ⑤.

**Resistance: Approximately 0Ω**

4. Reinstall any part removed.

NG →

Repair or replace harness between A/T control unit and terminal cord assembly. (Main harness)

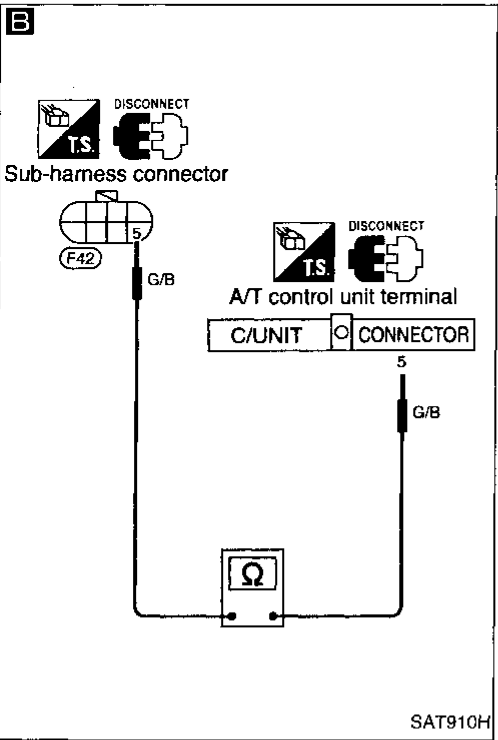

Perform self-diagnosis after driving for a while.

NG →

1. Perform A/T control unit input/output signal inspection.
2. If NG, recheck A/T control unit pin terminals for damage or loose connection with harness connector.

**INSPECTION END**

GI  
MA  
EM  
LC  
EC  
FE  
CL  
MT  
AT  
FA  
RA  
BR  
ST  
RS  
BT  
HA  
EL  
IDX

# TROUBLE DIAGNOSES

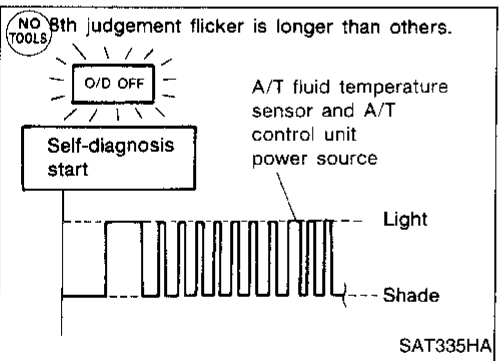
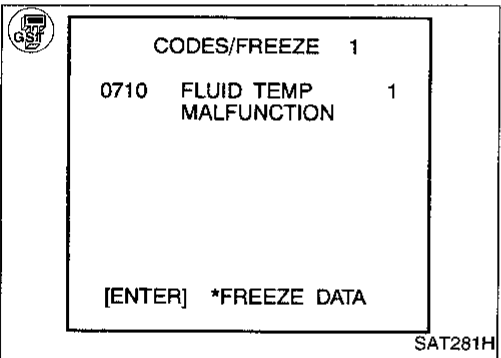
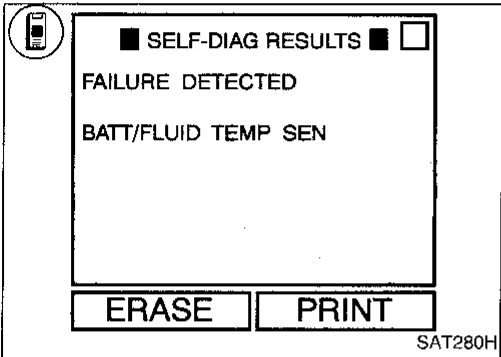
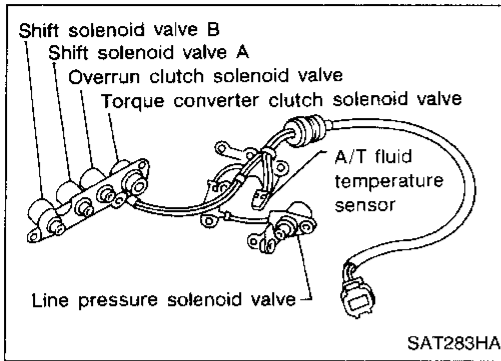

## Self-diagnosis (Cont'd)

### A/T FLUID TEMPERATURE SENSOR CIRCUIT AND A/T CONTROL UNIT POWER SOURCE CIRCUIT CHECKS

#### Parts description

The A/T fluid temperature sensor detects the ATF temperature and sends a signal to the A/T control unit.

#### Trouble judgement conditions

Diagnostic Trouble Code	Malfunction is detected when ...	Check Items (Possible Cause)
 BATT/FLUID TEMP  P0710  8th judgement flicker	<ul style="list-style-type: none"> <li>A/T control unit receives an excessively low or high voltage from the sensor.</li> </ul>	<ul style="list-style-type: none"> <li>Harness or connectors (The sensor circuit is open or short.)</li> <li>A/T fluid temperature sensor</li> </ul>

#### Diagnostic trouble code confirmation procedure

- 1) Start engine.  
2) Select "SELF-DIAG RESULTS" mode with CONSULT.  
3) Drive vehicle under the following conditions:  
Selector lever in D, vehicle speed higher than 10 km/h (6 MPH), throttle opening greater than 1/8 of the full open position, engine speed higher than 450 rpm and driving for more than 10 minutes.

OR

- 1) Start engine.  
2) Drive vehicle under the following conditions:  
Selector lever in D, vehicle speed higher than 10 km/h (6 MPH), throttle opening greater than 1/8 of the full open position, engine speed higher than 450 rpm and driving for more than 10 minutes.  
3) Select "MODE 3" with GST.

OR

- 1) Start engine.  
2) Drive vehicle under the following conditions:  
Selector lever in D, vehicle speed higher than 10 km/h (6 MPH), throttle opening greater than 1/8 of the full open position, engine speed higher than 450 rpm and driving for more than 10 minutes.  
3) Perform self-diagnosis.  
Refer to SELF-DIAGNOSIS PROCEDURE WITHOUT CONSULT OR GST, AT-47.

# TROUBLE DIAGNOSES

## Self-diagnosis (Cont'd)

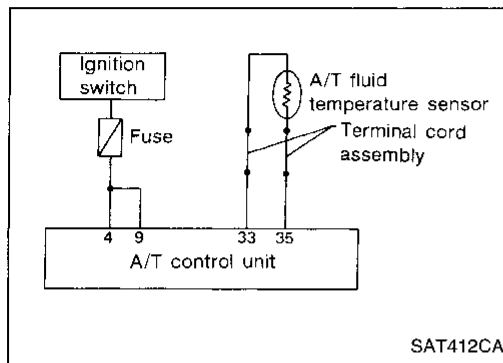

**A**

### CHECK A/T CONTROL UNIT POWER SOURCE.

1. Turn ignition switch to "ON" position. (Do not start engine.)
2. Check voltage between A/T control unit terminals ④, ⑨ and ground. **Battery voltage should exist.**

NG

- Check the following items:
- Harness for short or open between ignition switch and A/T control unit (Main harness)
  - Ignition switch and fuse Refer to EL section ("POWER SUPPLY ROUTING").

OK

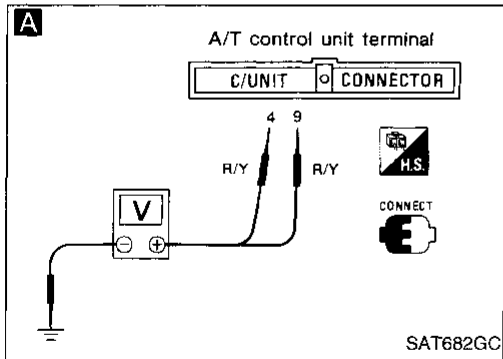

**B**

### CHECK A/T FLUID TEMPERATURE SENSOR WITH TERMINAL CORD ASSEMBLY.

1. Turn ignition switch to "OFF" position.
2. Disconnect terminal cord assembly connector in engine compartment.
3. Check resistance between terminals ⑥ and ⑦ when A/T is cold.

NG

1. Remove oil pan.
2. Check the following items:
  - A/T fluid temperature sensor (Refer to "Electrical Components Inspection", AT-106.)
  - Harness of terminal cord assembly for short or open

#### Resistance:

**Cold [20°C (68°F)]**

**Approximately 2.5 kΩ**

4. Reinstall any part removed.

OK

Ⓐ

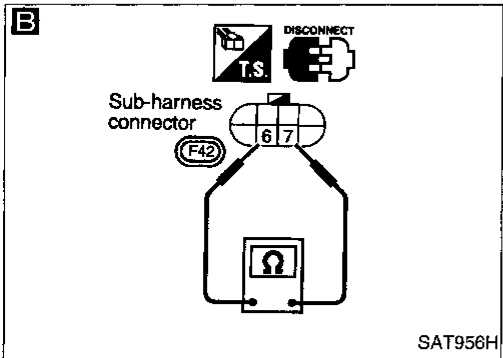

GI

MA

EM

LC

EC

FE

CL

MT

**AT**

FA

RA

BR

ST

RS

BT

HA

EL

IDX

# TROUBLE DIAGNOSES

## Self-diagnosis (Cont'd)

**C**

☆MONITOR	☆NO FAIL	
VHCL/S SE·A/T	0km/h	
VHCL/S SE·MTR	5km/h	
THRTL POS SEN	0.4V	
FLUID TEMP SE	1.2V	
BATTERY VOLT	13.4V	
ENGINE SPEED	1024rpm	
OVERDRIVE SW	O N	
P/N POSI SW	O N	
R POSITION SW	OFF	

RECORD

SAT076H

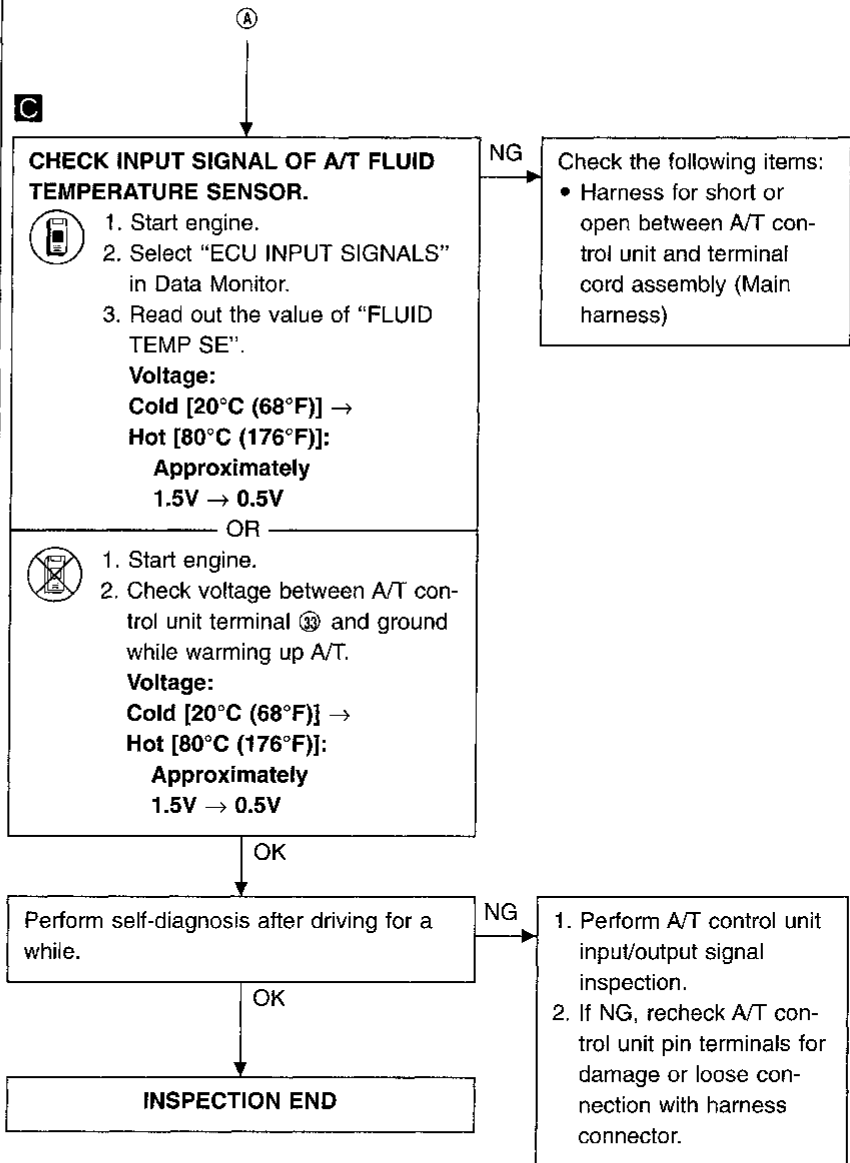
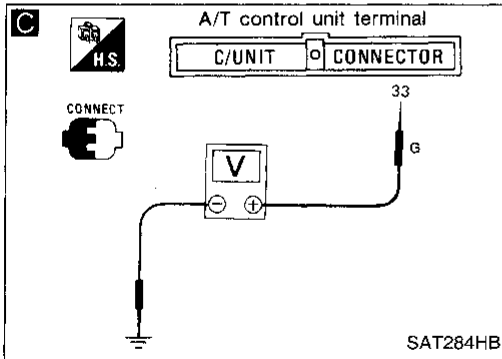

# TROUBLE DIAGNOSES



## Self-diagnosis (Cont'd)

### ENGINE SPEED SIGNAL CIRCUIT CHECK

#### Parts description

The engine speed signal is sent from the ECM to the A/T control unit.

#### Trouble judgement conditions

Diagnostic Trouble Code	Malfunction is detected when ...	Check Items (Possible Cause)
 ENGINE SPEED SIG   P0725   9th judgement flicker	<ul style="list-style-type: none"> <li>A/T control unit does not receive the proper voltage signal from ECM.</li> </ul>	<ul style="list-style-type: none"> <li>Harness or connectors (The sensor circuit is open or short.)</li> </ul>

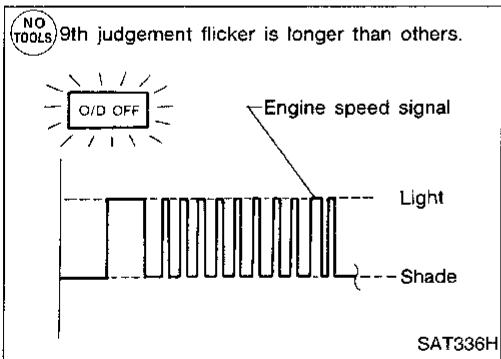
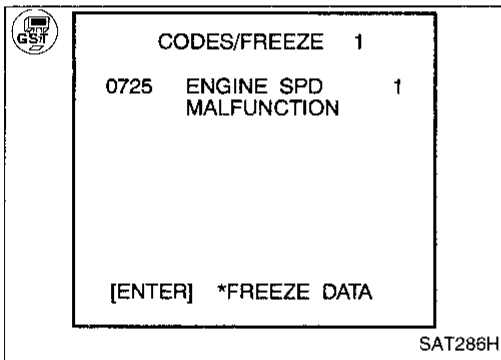
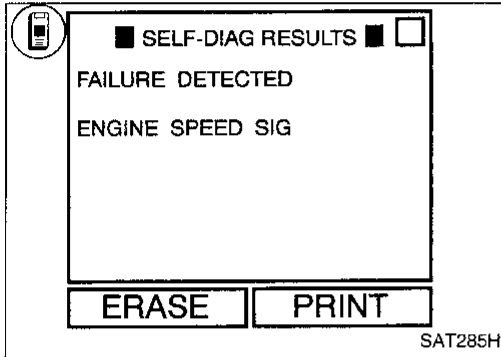

#### Diagnostic trouble code confirmation procedure

-  1) Start engine.  
 2) Select "SELF-DIAG RESULTS" mode with CONSULT.  
 3) Drive vehicle under the following conditions:  
 Selector lever in D, vehicle speed higher than 10 km/h (6 MPH), throttle opening greater than 1/8 of the full throttle position and driving for more than 10 seconds.

-  1) Start engine.  
 2) Drive vehicle under the following conditions:  
 Selector lever in D, vehicle speed higher than 10 km/h (6 MPH), throttle opening greater than 1/8 of the full throttle position and driving for more than 10 seconds.  
 3) Select "MODE 3" with GST.

-  1) Start engine.  
 2) Drive vehicle under the following conditions:  
 Selector lever in D, vehicle speed higher than 10 km/h (6 MPH), throttle opening greater than 1/8 of the full throttle position and driving for more than 10 seconds.  
 3) Perform self-diagnosis.  
 Refer to SELF-DIAGNOSIS PROCEDURE WITHOUT CONSULT OR GST, AT-47.

GI

MA

EM

LC

EC

FE

CL

MT

AT

FA

RA

BR

ST

RS

BT

HA

EL

IDX

# TROUBLE DIAGNOSES

## Self-diagnosis (Cont'd)

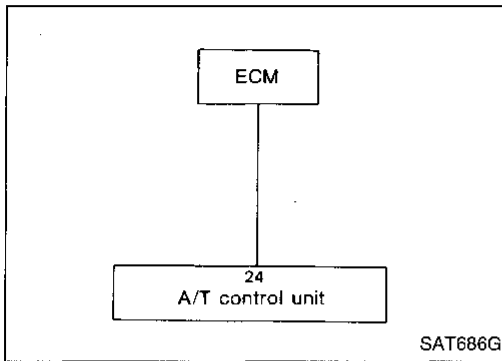

**A**

☆MONITOR	☆NO FAIL	
VHCL/S SE·A/T		0km/h
VHCL/S SE·MTR		5km/h
THRTL POS SEN		0.4V
FLUID TEMP SE		1.2V
BATTERY VOLT		13.4V
ENGINE SPEED		1024rpm
OVERDRIVE SW		O N
P/N POSI SW		O N
R POSITION SW		OFF

RECORD

SAT076H

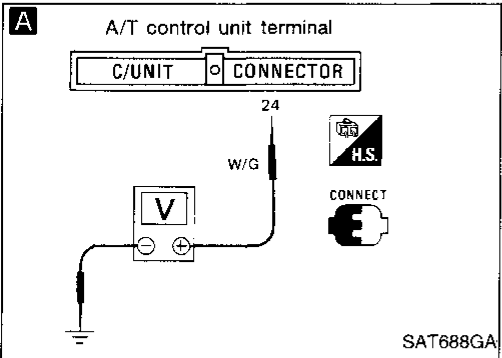

Perform diagnostic test mode II (self-diagnostic results) for engine control. Check ignition signal circuit condition.

NG

Check ignition signal circuit for engine control. Refer to EC section ["Ignition signal (DTC: 0201)", "TROUBLE DIAGNOSIS FOR DTC P1320"].

OK

**A**

**CHECK INPUT SIGNAL.**

- Start engine.
- Select "ECU INPUT SIGNALS" in Data Monitor.
- Read out the value of "ENGINE SPEED".  
Check engine speed changes according to throttle position.

OR

NG

Check the following items:

- Harness for short or open between A/T control unit and ignition coil.
- Resistor
- Ignition coil

Refer to EC section ["Ignition signal (DTC: 0201)", "TROUBLE DIAGNOSIS FOR DTC P1320"].

- Start engine.
- Check voltage between A/T control unit terminal ② and ground.  
**Voltage: 0.9 - 4.5V**

OK

Perform self-diagnosis again after driving for a while.

NG

- Perform A/T control unit input/output signal inspection.
- If NG, recheck A/T control unit pin terminals for damage or loose connection with harness connector.

OK

**INSPECTION END**

# TROUBLE DIAGNOSES



## Self-diagnosis (Cont'd)

### LINE PRESSURE SOLENOID VALVE CIRCUIT CHECK

#### Parts description

The line pressure solenoid valve regulates the oil pump discharge pressure to suit the driving condition in response to a signal sent from the A/T control unit.

#### Trouble judgement conditions

Diagnostic Trouble Code	Malfunction is detected when ...	Check Items (Possible Cause)
 LINE PRESSURE S/V  P0745  10th judgement flicker	<ul style="list-style-type: none"> <li>A/T control unit detects the improper voltage drop when it tries to operate the solenoid valve.</li> </ul>	<ul style="list-style-type: none"> <li>Harness or connectors (The solenoid circuit is open or short.)</li> <li>Line pressure solenoid valve</li> </ul>

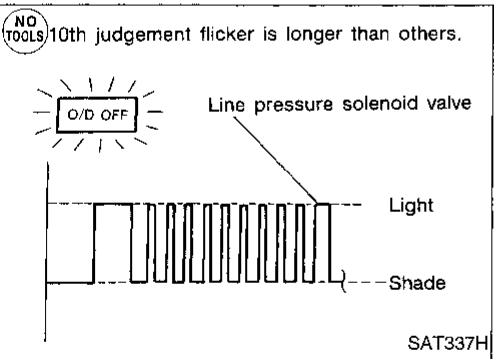
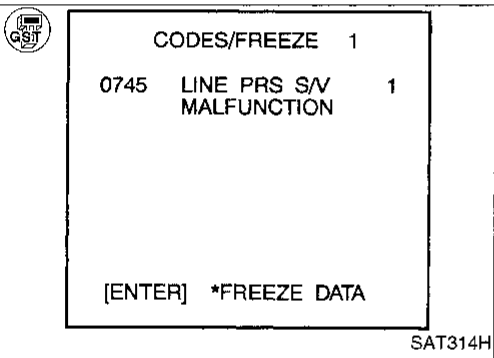
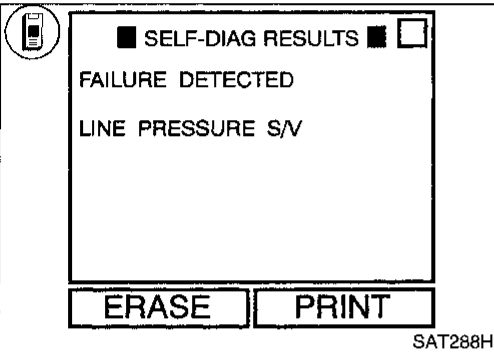
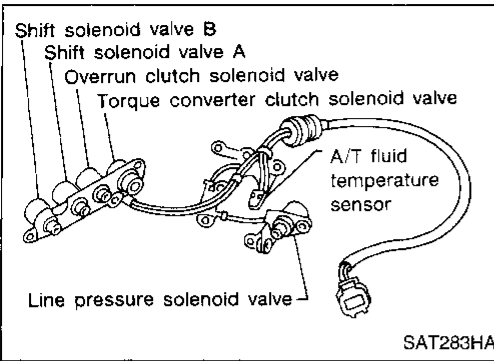

#### Diagnostic trouble code confirmation procedure

- Start engine.
  - Select "SELF-DIAG RESULTS" mode with CONSULT.
  - With brake pedal depressed, shift the lever from P → N → D → N → P.
- OR
- Start engine.
  - With brake pedal depressed, shift the lever from P → N → D → N → P.
  - Select "MODE 3" with GST.
- OR
- Start engine.
  - With brake pedal depressed, shift the lever from P → N → D → N → P.
  - Perform self-diagnosis. Refer to SELF-DIAGNOSIS PROCEDURE WITHOUT CONSULT OR GST, AT-47.

GI  
MA  
EM  
LC  
EC  
FE  
CL  
MT  
AT  
FA  
RA  
BR  
ST  
RS  
BT  
HA  
EL  
IDX

# TROUBLE DIAGNOSES

## Self-diagnosis (Cont'd)

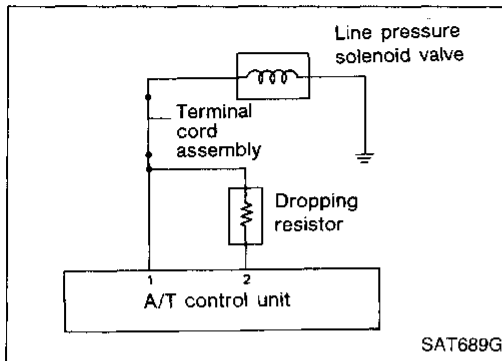

**A**

**CHECK GROUND CIRCUIT.**

1. Turn ignition switch to "OFF" position.
2. Disconnect terminal cord assembly connector in engine compartment.
3. Check resistance between terminal ④ and ground.

**Resistance: 2.5 - 5Ω**

NG

1. Remove control valve assembly. Refer to "ON-VEHICLE SERVICE", AT-124.
2. Check the following items:
  - Line pressure solenoid valve (Refer to "Electrical Components Inspection", AT-105.)
  - Harness of terminal cord assembly for short or open

OK

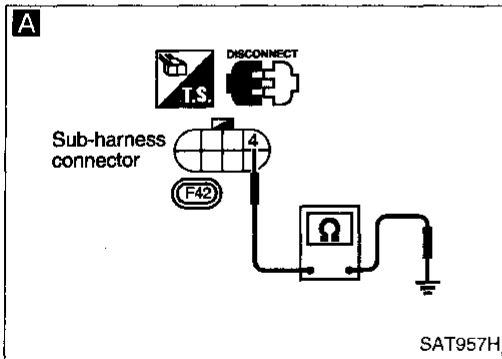

**B**

**CHECK POWER SOURCE CIRCUIT.**

1. Turn ignition switch to "OFF" position.
2. Disconnect A/T control unit harness connector.
3. Check resistance between terminal ④ and A/T control unit terminal ②.

**Resistance: 11.2 - 12.8Ω**

NG

Check the following items:

- Dropping resistor (Refer to "Electrical Components Inspection", AT-108.)
- Harness for short or open between A/T control unit ② and terminal cord assembly (Main harness)

OK

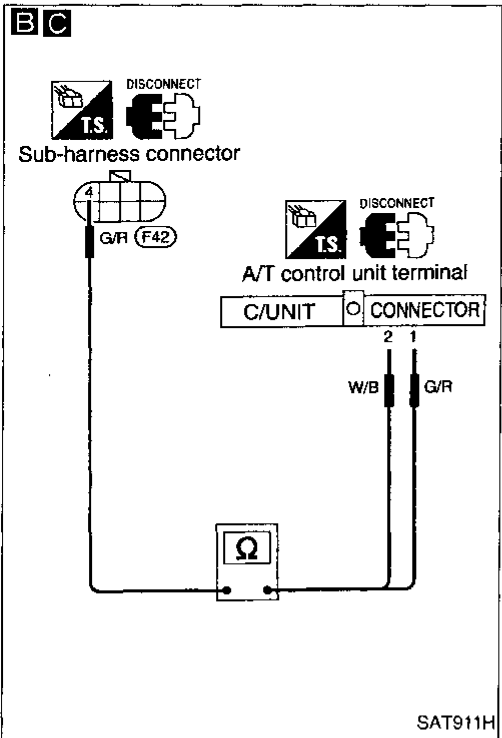

**C**

**CHECK POWER SOURCE CIRCUIT.**

1. Turn ignition switch to "OFF" position.
2. Check resistance between terminal ④ and A/T control unit terminal ①.

**Resistance: Approximately 0Ω**

3. Reinstall any part removed.

NG

Repair or replace harness between A/T control unit ① and terminal cord assembly.

OK

Perform self-diagnosis after driving for a while.

NG

1. Perform A/T control unit input/output signal inspection.
2. If NG, recheck A/T control unit pin terminals for damage or loose connection with harness connector.

OK

**INSPECTION END**



# TROUBLE DIAGNOSES

## Self-diagnosis (Cont'd)

### INHIBITOR, OVERDRIVE AND THROTTLE POSITION SWITCH CIRCUIT CHECKS

#### Parts description

**Inhibitor switch**

Detects the selector lever position and sends a signal to the A/T control unit.

**Overdrive switch**

Detects the overdrive switch position (ON or OFF) and sends a signal to the A/T control unit.

**Throttle position switch**

Consists of a wide-open throttle position switch and a closed throttle position switch.

The wide-open position switch sends a signal to the A/T control unit when the throttle valve is open at least 1/2 of the full throttle position. The closed throttle position switch sends a signal to the A/T control unit when the throttle valve is fully closed.

#### Overall function check

-  1) Start engine.  
 2) Select "SELF-DIAG RESULTS" mode for ECM with CONSULT.  
 3) Drive vehicle under the following conditions:  
 Selector lever in D, OD control switch in "OFF" position, vehicle speed higher than 10 km/h (6 MPH), throttle opening greater than 1/2 of the full throttle position and driving for more than 5 seconds.

OR

-  1) Start engine.  
 2) Drive vehicle under the following conditions:  
 Selector lever in D, OD control switch in "OFF" position, vehicle speed higher than 10 km/h (6 MPH), throttle opening greater than 1/2 of the full throttle position and driving for more than 5 seconds.  
 3) Select "MODE 3" with GST.

OR

-  1) Start engine.  
 2) Drive vehicle under the following conditions:  
 Selector lever in D, OD control switch in "OFF" position, vehicle speed higher than 10 km/h (6 MPH), throttle opening greater than 1/2 of the full throttle position and driving for more than 5 seconds.  
 3) Perform self-diagnosis for ECM.  
 Refer to EC section ["Malfunction Indicator Lamp (MIL)", "ON-BOARD DIAGNOSTIC SYSTEM DESCRIPTION"].

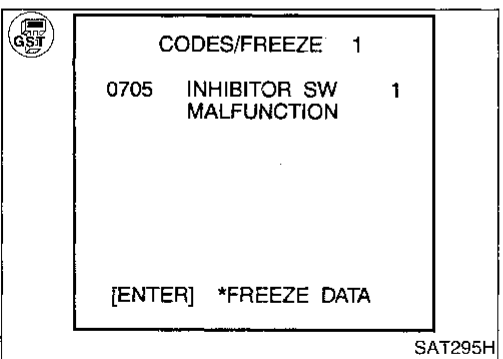
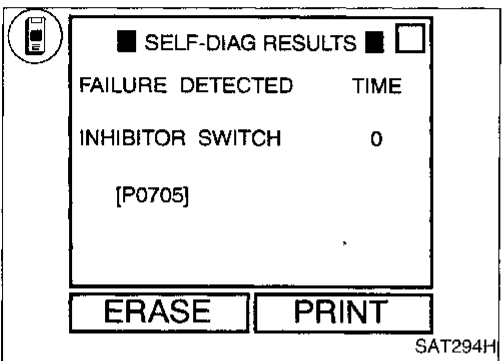
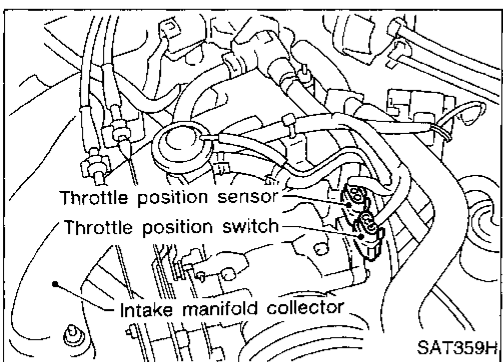
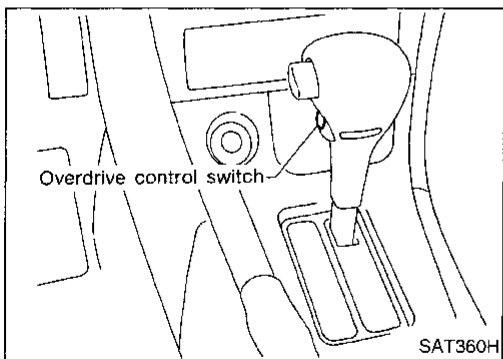
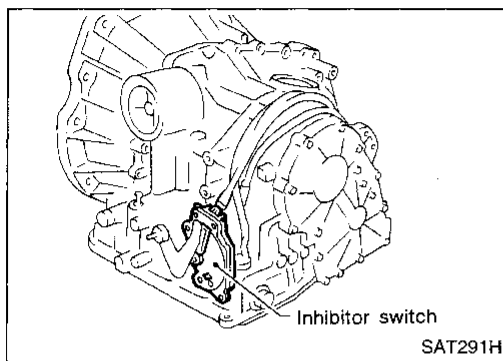

GI

MA

EM

LC

EC

FE

CL

MT

AT

FA

RA

BR

ST

RS

BT

HA

EL

IDX

# TROUBLE DIAGNOSES

## Self-diagnosis (Cont'd)

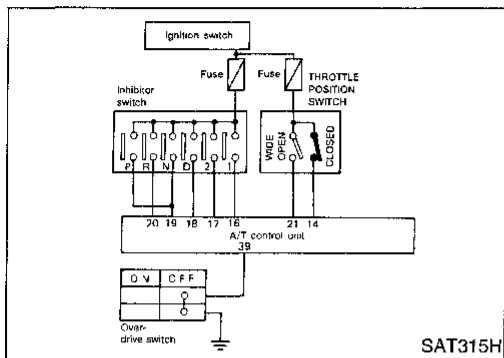

SAT315H

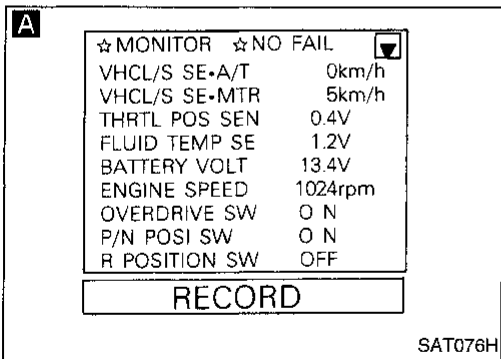

SAT076H

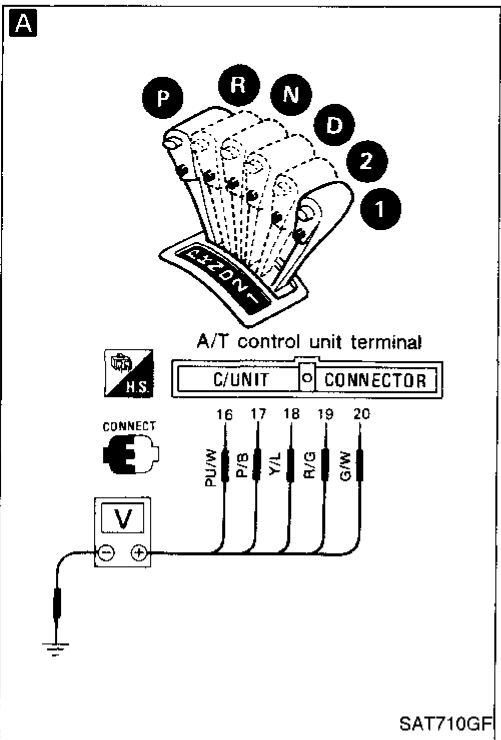

SAT710GF

A

### CHECK INHIBITOR SWITCH CIRCUIT.



1. Turn ignition switch to "ON" position. (Do not start engine.)
2. Select "ECU INPUT SIGNALS" in Data Monitor.
3. Read out "R, N, D, 1 and 2 position switches" moving selector lever to each position. Check the signal of the selector lever position is indicated properly.

NG

- Check the following items:
- Inhibitor switch (Refer to "Electrical Components Inspection", AT-107.)
  - Harness for short or open between ignition switch and inhibitor switch (Main harness)
  - Harness for short or open between inhibitor switch and A/T control unit (Main harness)

OR



1. Turn ignition switch to "ON" position. (Do not start engine.)
2. Check voltage between A/T control unit terminals (16, 17, 18, 19, 20) and ground while moving selector lever through each position.

#### Voltage:

- B: Battery voltage**
- 0: 0V**

Lever position	Terminal No.				
	16	17	18	19	20
P, N	B	0	0	0	0
R	0	B	0	0	0
D	0	0	B	0	0
2	0	0	0	B	0
1	0	0	0	0	B

OK

A

# TROUBLE DIAGNOSES

## Self-diagnosis (Cont'd)

**B**

☆ MONITOR	☆ NO FAIL	▼
VHCL/S SE•A/T	0km/h	
VHCL/S SE•MTR	5km/h	
THRTL POS SEN	0.4V	
FLUID TEMP SE	1.2V	
BATTERY VOLT	13.4V	
ENGINE SPEED	1024rpm	
OVERDRIVE SW	O N	
P/N POSI SW	O N	
R POSITION SW	OFF	

RECORD

SAT076H

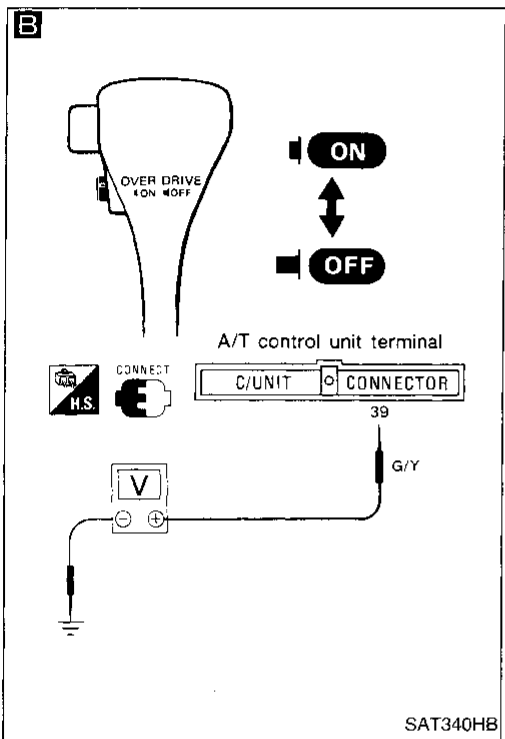

**B**

**CHECK OVERDRIVE SWITCH CIRCUIT.**

1. Turn ignition switch to "ON" position. (Do not start engine.)

2. Select "ECU INPUT SIGNALS" in Data Monitor.

3. Read out "OVERDRIVE SWITCH".

Check the signal of the overdrive switch is indicated properly. (Overdrive switch "ON" displayed on CONSULT means overdrive "OFF".)

OR

1. Turn ignition switch to "ON" position. (Do not start engine.)

2. Check voltage between A/T control unit terminal ③ and ground when overdrive switch is "ON" and "OFF".

Switch position	Voltage
ON	Battery voltage
OFF	1V or less

NG

Check the following items:

- Overdrive switch (Refer to "Electrical Components Inspection", AT-107.)
- Harness for short or open between A/T control unit and overdrive switch (Main harness)
- Harness of ground circuit for overdrive switch (Main harness) for short or open

OK

**B**

GI  
MA  
EM  
LC  
EC  
FE  
CL  
MT  
AT  
FA  
RA  
BR  
ST  
RS  
BT  
HA  
EL  
IDX

# TROUBLE DIAGNOSES

## Self-diagnosis (Cont'd)

**C**

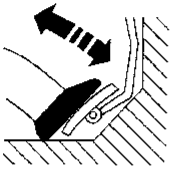

☆ MONITOR	☆ NO FAIL	
D POSITION SW	OFF	
2 POSITION SW	OFF	
1 POSITION SW	OFF	
ASCD • CRUISE	OFF	
ASCD • OD CUT	OFF	
KICKDOWN SW	OFF	
POWERSHIFT SW	OFF	
CLOSED THL/SW	ON	
W/O THRL/P-SW	OFF	

**RECORD**

SAT963H

**B**

**C**

**CHECK THROTTLE POSITION SWITCH CIRCUIT.**

- Turn ignition switch to "ON" position. (Do not start engine.)
- Select "ECU INPUT SIGNALS" in Data Monitor.
- Read out "CLOSED THL/SW" and "W/O THRL/P-SW" depressing and releasing accelerator pedal.

Check the signal of throttle position switch is indicated properly.

Accelerator pedal condition	Data Monitor	
	CLOSED THL/SW	W/O THRL/P-SW
Released	ON	OFF
Fully depressed	OFF	ON

NG

Check the following items:

- Throttle position switch Refer to "Electrical Components Inspection", AT-108.
- Harness for short or open between ignition switch and throttle position switch (Main harness)
- Harness for short or open between throttle position switch and A/T control unit (Main harness)

**C**

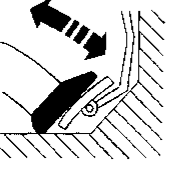
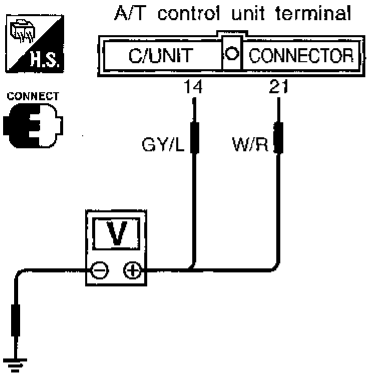
A/T control unit terminal

C/UNIT CONNECTOR

14 21

GY/L W/R

V

SAT964H

OR

- Turn ignition switch to "ON" position. (Do not start engine.)
- Check voltage between A/T control unit terminals ⑭, ⑰ and ground while depressing and releasing accelerator pedal slowly. (after warming up engine)

Accelerator pedal condition	Voltage	
	Terminal No. ⑭	Terminal No. ⑰
Released	Battery voltage	1V or less
Fully depressed	1V or less	Battery voltage

OK

Perform self-diagnosis again after driving for a while.

OK

**INSPECTION END**

NG

- Perform A/T control unit input/output signal inspection.
- If NG, recheck A/T control unit pin terminals for damage or loose connection with harness connector.

# TROUBLE DIAGNOSES

## Self-diagnosis (Cont'd)

### IMPROPER SHIFTING TO 1ST GEAR POSITION

#### Description

- This is a "failure" item indicated by the MIL.
- This is indicated when the vehicle is being driven at any gear position other than 1st while the A/T control unit is instructing the A/T to shift the gear in the 1st position.
- The detected item, "A/T 1ST SIGNAL", is not determined as a fault unless the A/T control unit self-diagnosis system is in the "No Failure" condition. When "A/T 1ST SIGNAL" is displayed, it indicates that the gears are not properly shifted. The problem is not caused by electrical failure of the A/T (circuits open or shorted) but by mechanical failure (control valve sticking, improper solenoid valve operation, etc.).

#### Overall function check

- 1) Start engine and warm up ATF.
- 2) Select "SELF-DIAG RESULTS" mode for ECM with CONSULT.
- 3) Start vehicle with selector lever in D and throttle opening halfway. Check that vehicle runs through gear shift of  $D_1 \rightarrow D_2 \rightarrow D_3 \rightarrow D_4$ , in accordance with shift schedule. Refer to shift schedule, AT-36.

OR

- 1) Start engine and warm up ATF.
- 2) Start vehicle with selector lever in D and throttle opening halfway. Check that vehicle runs through gear shift of  $D_1 \rightarrow D_2 \rightarrow D_3 \rightarrow D_4$ , in accordance with shift schedule. Refer to shift schedule, AT-36.
- 3) Select "MODE 3" with GST.

OR

- 1) Start engine and warm up ATF.
- 2) Start vehicle with selector lever in D and throttle opening halfway. Check that vehicle runs through gear shift of  $D_1 \rightarrow D_2 \rightarrow D_3 \rightarrow D_4$ , in accordance with shift schedule. Refer to shift schedule, AT-36.
- 3) Perform self-diagnosis for ECM.  
Refer to EC section ["Malfunction Indicator Lamp (MIL)", "ON-BOARD DIAGNOSTIC SYSTEM DESCRIPTION"].

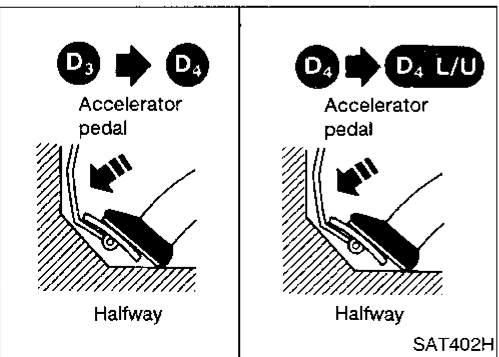
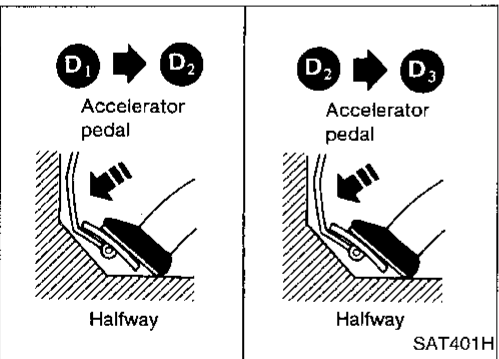
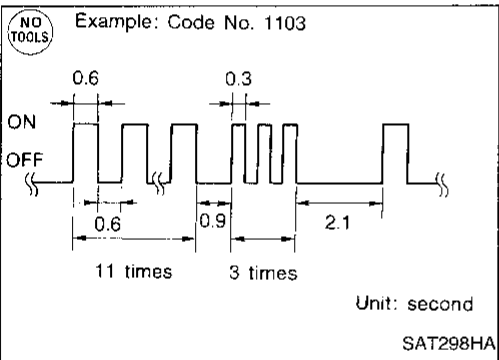
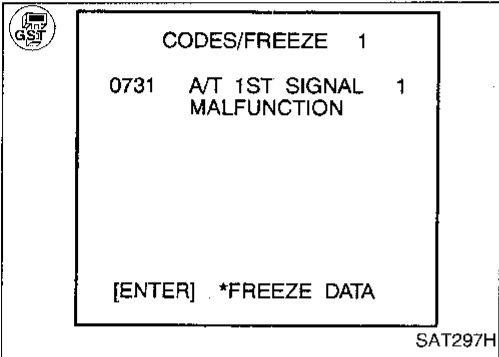
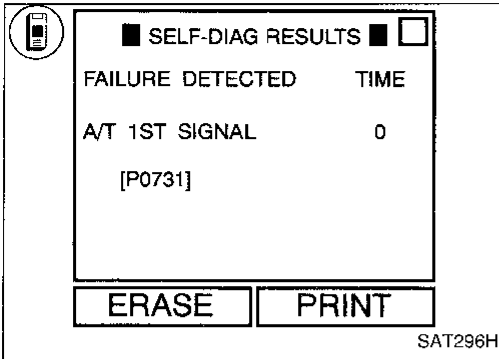

GI

MA

EM

LC

EC

FE

CL

MT

AT

FA

RA

BR

ST

RS

BT

HA

EL

IDX

# TROUBLE DIAGNOSES

## Self-diagnosis (Cont'd)

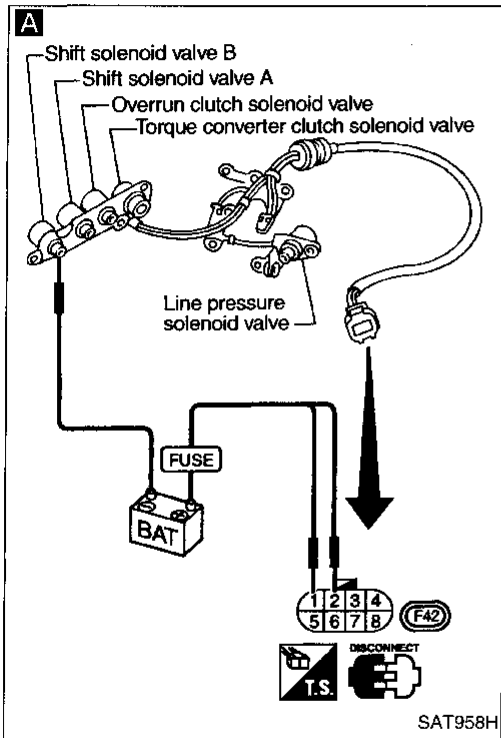

**A**

**CHECK SHIFT SOLENOID VALVE.**

1. Remove control valve assembly. Refer to "ON-VEHICLE SERVICE", AT-124.
2. Check shift solenoid valve operation.
  - Shift solenoid valve A
  - Shift solenoid valve B
 Refer to "Electrical Components Inspection", AT-106.

NG → Repair or replace shift solenoid valve assembly.

OK

**B**

**CHECK CONTROL VALVE.**

1. Disassemble control valve assembly. Refer to "REPAIR FOR COMPONENT PARTS — Control Valve Assembly —", AT-153.
2. Check to ensure that:
  - Valve, sleeve and plug slide along valve bore under their own weight.
  - Valve, sleeve and plug are free from burrs, dents and scratches.
  - Control valve springs are free from damage, deformation and fatigue.
  - Hydraulic line is free from obstacles.

NG → Repair control valve assembly.

OK

Check again.

OK

**INSPECTION END**

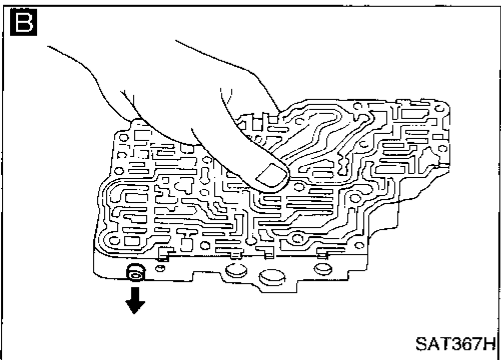

# TROUBLE DIAGNOSES

## Self-diagnosis (Cont'd)

### IMPROPER SHIFTING TO 2ND GEAR POSITION

#### Description

- This is a "failure" item indicated by the MIL.
- This is indicated when the vehicle is being driven at any gear position other than 2nd while the A/T control unit is instructing the A/T to shift the gear in the 2nd position.
- The detected item, "A/T 2ND SIGNAL", is not determined as a fault unless the A/T control unit self-diagnosis is in the "No Failure" condition. When "A/T 2ND SIGNAL" is displayed, it indicates that the gears are not properly shifted. The problem is not caused by electrical failure of the A/T (circuits open or shorted) but by mechanical failure (control valve sticking, improper solenoid valve operation, etc.).

#### Overall function check

- 1) Start engine and warm up ATF.
- 2) Select "SELF-DIAG RESULTS" mode for ECM with CONSULT.
- 3) Start vehicle with selector lever in D and throttle opening halfway. Check that vehicle runs through gear shift of  $D_1 \rightarrow D_2 \rightarrow D_3 \rightarrow D_4$ , in accordance with shift schedule. Refer to shift schedule, AT-36.

OR

- 1) Start engine and warm up ATF.
- 2) Start vehicle with selector lever in D and throttle opening halfway. Check that vehicle runs through gear shift of  $D_1 \rightarrow D_2 \rightarrow D_3 \rightarrow D_4$ , in accordance with shift schedule. Refer to shift schedule, AT-36.
- 3) Select "MODE 3" with GST.

OR

- 1) Start engine and warm up ATF.
- 2) Start vehicle with selector lever in D and throttle opening halfway. Check that vehicle runs through gear shift of  $D_1 \rightarrow D_2 \rightarrow D_3 \rightarrow D_4$ , in accordance with shift schedule. Refer to shift schedule, AT-36.
- 3) Perform self-diagnosis for ECM.

Refer to EC section ["Malfunction Indicator Lamp (MIL)", "ON-BOARD DIAGNOSTIC SYSTEM DESCRIPTION"].

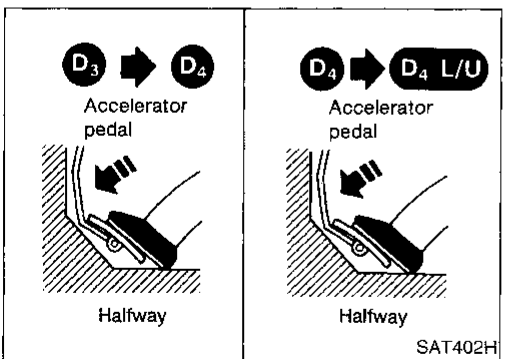
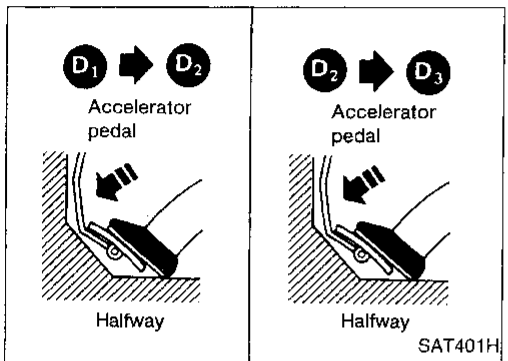
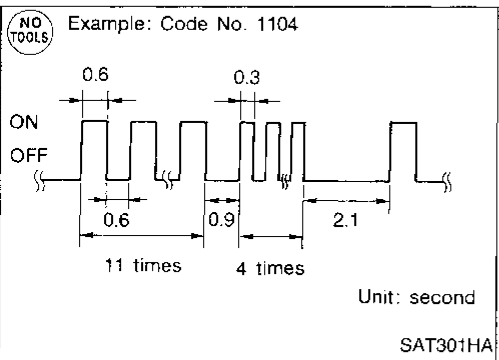
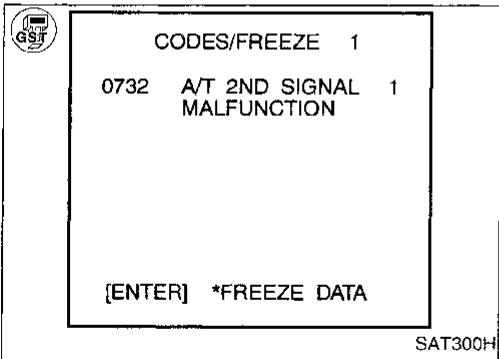
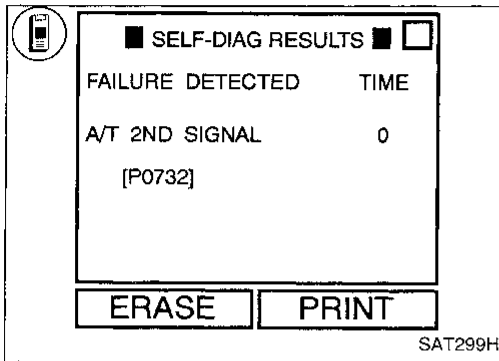

# TROUBLE DIAGNOSES

## Self-diagnosis (Cont'd)

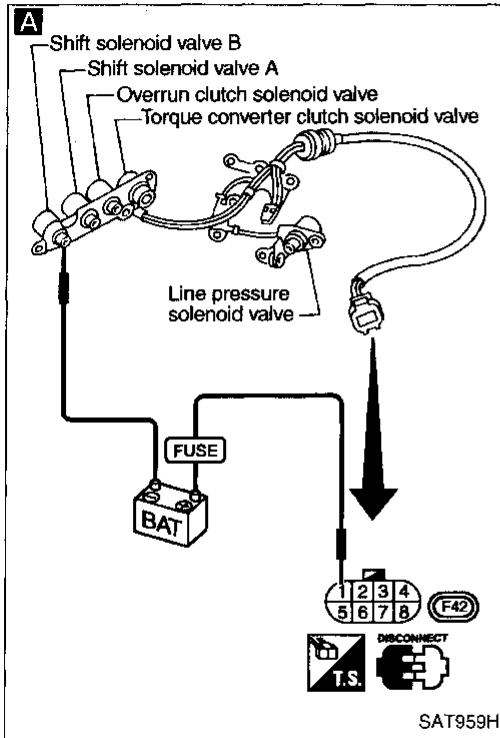

**A**

**CHECK SHIFT SOLENOID VALVE.**

1. Remove control valve assembly. Refer to "ON-VEHICLE SERVICE", AT-124.
2. Check shift solenoid valve operation.
  - Shift solenoid valve B  
Refer to "Electrical Components Inspection", AT-106.

NG → Repair or replace shift solenoid valve assembly.

OK

**B**

**CHECK CONTROL VALVE.**

1. Disassemble control valve assembly. Refer to "REPAIR FOR COMPONENT PARTS — Control Valve Assembly —", AT-153.
2. Check to ensure that:
  - Valve, sleeve and plug slide along valve bore under their own weight.
  - Valve, sleeve and plug are free from burrs, dents and scratches.
  - Control valve springs are free from damage, deformation and fatigue.
  - Hydraulic line is free from obstacles.

NG → Repair control valve assembly.

OK

Check again.

OK

**INSPECTION END**

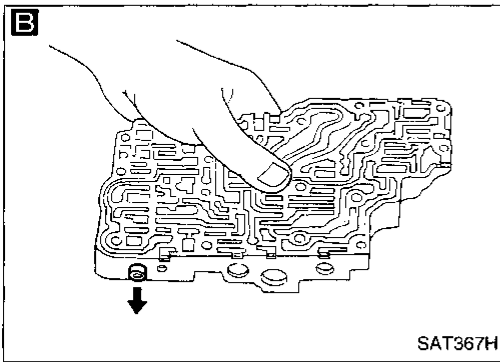



# TROUBLE DIAGNOSES

## Self-diagnosis (Cont'd)

### IMPROPER SHIFTING TO 3RD GEAR POSITION

#### Description

- This is a "failure" item indicated by the MIL.
- This is indicated when the vehicle is being driven at any gear position other than 3rd while the A/T control unit is instructing the A/T to shift the gear in the 3rd position.
- The detected item, "A/T 3RD SIGNAL", is not determined as a fault unless the A/T control unit self-diagnosis system is in the "No Failure" condition. When "A/T 3RD SIGNAL" is displayed, it indicates that the gears are not properly shifted. The problem is not caused by electrical failure of the A/T (circuits open or shorted) but by mechanical failure (control valve sticking, improper solenoid valve operation, malfunctioning servo piston or brake band, etc.).

#### Overall function check

- 1) Start engine and warm up ATF.
- 2) Select "SELF-DIAG RESULTS" mode for ECM with CONSULT.
- 3) Start vehicle with selector lever in D and throttle opening halfway. Check that vehicle runs through gear shift of  $D_1 \rightarrow D_2 \rightarrow D_3 \rightarrow D_4$ , in accordance with shift schedule. Refer to shift schedule, AT-36.

OR

- 1) Start engine and warm up ATF.
- 2) Start vehicle with selector lever in D and throttle opening halfway. Check that vehicle runs through gear shift of  $D_1 \rightarrow D_2 \rightarrow D_3 \rightarrow D_4$ , in accordance with shift schedule. Refer to shift schedule, AT-36.
- 3) Select "MODE 3" with GST.

OR

- 1) Start engine and warm up ATF.
- 2) Start vehicle with selector lever in D and throttle opening halfway. Check that vehicle runs through gear shift of  $D_1 \rightarrow D_2 \rightarrow D_3 \rightarrow D_4$ , in accordance with shift schedule. Refer to shift schedule, AT-36.
- 3) Perform self-diagnosis for ECM.  
Refer to EC section ["Malfunction Indicator Lamp (MIL)", "ON-BOARD DIAGNOSTIC SYSTEM DESCRIPTION"].

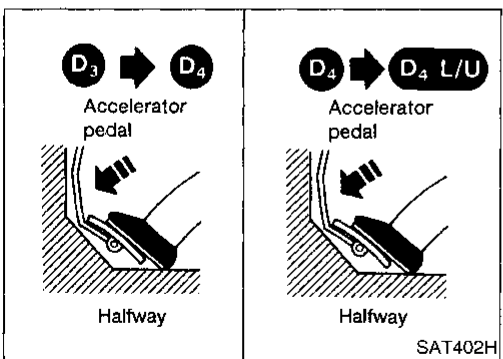
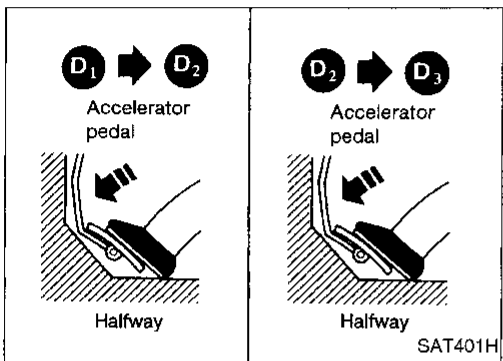
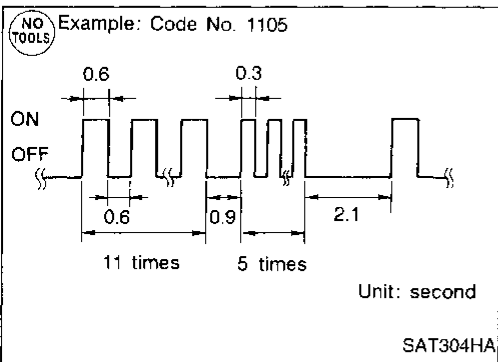
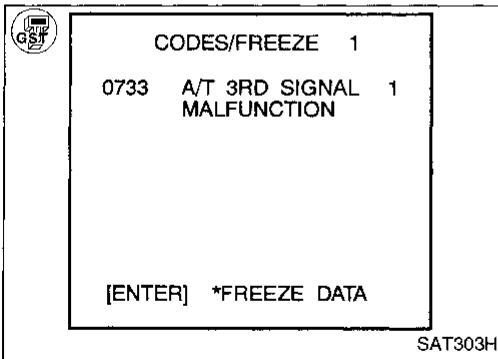
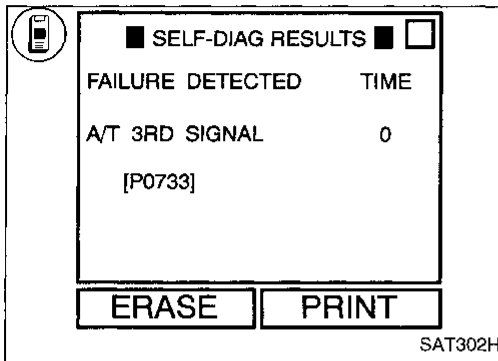

# TROUBLE DIAGNOSES

## Self-diagnosis (Cont'd)

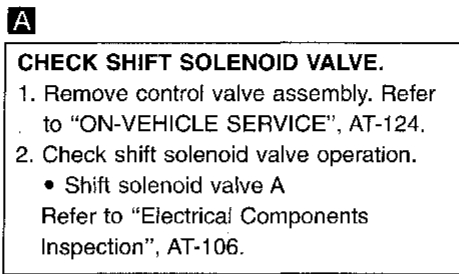
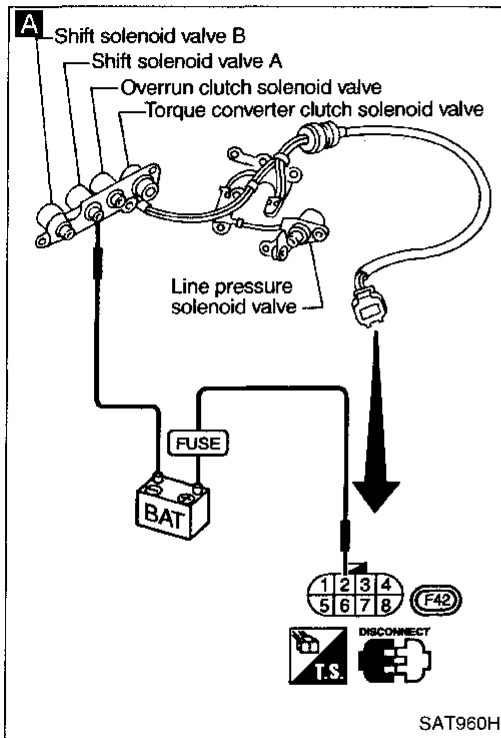

NG → Repair or replace shift solenoid valve assembly.

OK

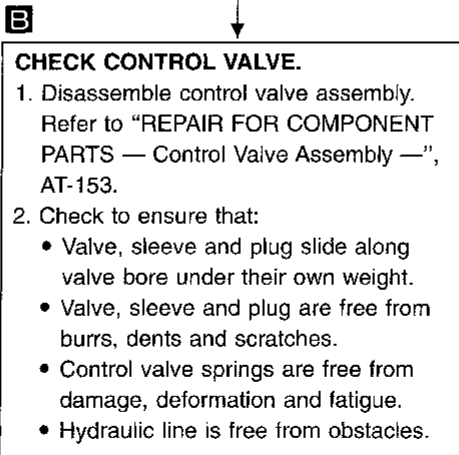

NG → Repair control valve assembly.

OK

Check again.

OK

**INSPECTION END**

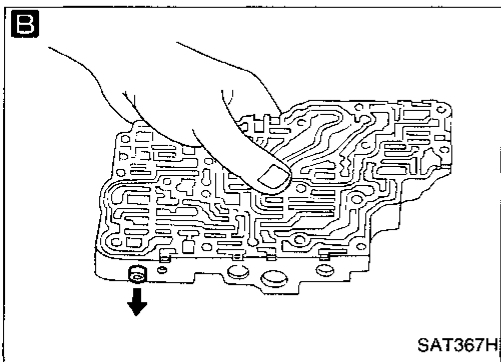

# TROUBLE DIAGNOSES

## Self-diagnosis (Cont'd)

### IMPROPER SHIFTING TO 4TH GEAR POSITION OR IMPROPER TORQUE CONVERTER CLUTCH OPERATION

#### Description

- This is a "failure" item indicated by the MIL.
- This is indicated when the vehicle is being driven at any gear position other than 4th while the A/T control unit is instructing the A/T to shift the gear in the 4th position. Also, this is indicated when the vehicle is being driven without the torque converter clutch locked up while the A/T control unit is instructing the A/T to lock up the torque converter clutch.
- The detected item, "A/T 4TH OR TCC", is not determined as a fault unless the A/T control unit self-diagnosis system is in the "No Failure" condition. When "A/T 4TH OR TCC" is displayed, it indicates that the gears are not properly shifted. The problem is not caused by electrical failure of the A/T (circuits open or shorted) but by mechanical failure (control valve sticking, improper solenoid valve operation, malfunctioning oil pump or torque converter clutch, etc.).

#### Overall function check

- 1) Start engine and warm up ATF.
- 2) Select "SELF-DIAG RESULTS" mode for ECM with CONSULT.
- 3) Start vehicle with selector lever in D and throttle opening halfway. Check that vehicle runs through gear shift of  $D_1 \rightarrow D_2 \rightarrow D_3 \rightarrow D_4 \rightarrow D_4$  lock-up, in accordance with shift schedule. Refer to shift schedule, AT-36.

OR

- 1) Start engine and warm up ATF.
- 2) Start vehicle with selector lever in D and throttle opening halfway. Check that vehicle runs through gear shift of  $D_1 \rightarrow D_2 \rightarrow D_3 \rightarrow D_4 \rightarrow D_4$  lock-up, in accordance with shift schedule. Refer to shift schedule, AT-36.
- 3) Select "MODE 3" with GST.

OR

- 1) Start engine and warm up ATF.
- 2) Start vehicle with selector lever in D and throttle opening halfway. Check that vehicle runs through gear shift of  $D_1 \rightarrow D_2 \rightarrow D_3 \rightarrow D_4 \rightarrow D_4$  lock-up, in accordance with shift schedule. Refer to shift schedule, AT-36.
- 3) Perform self-diagnosis for ECM.  
Refer to EC section ["Malfunction Indicator Lamp (MIL)", "ON-BOARD DIAGNOSTIC SYSTEM DESCRIPTION"].

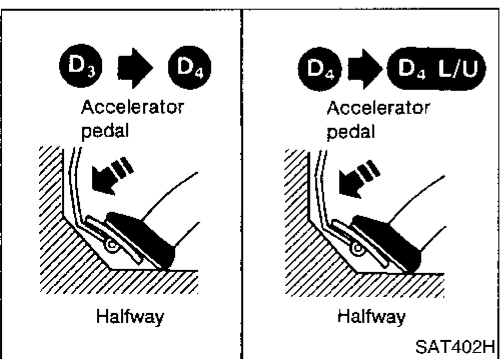
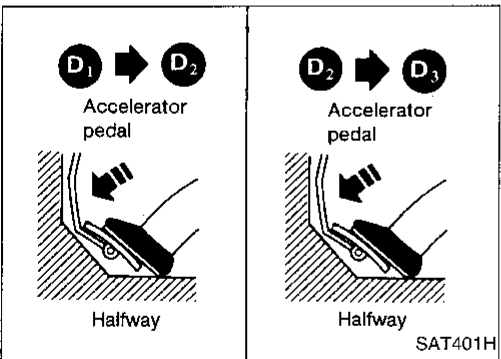
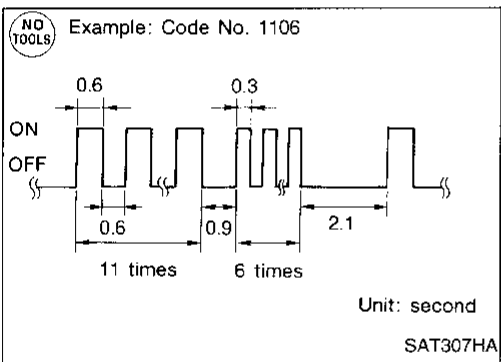
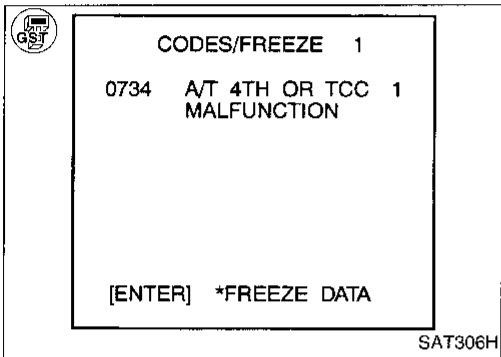
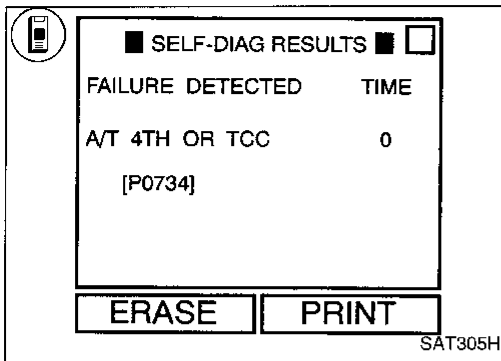

# TROUBLE DIAGNOSES

## Self-diagnosis (Cont'd)

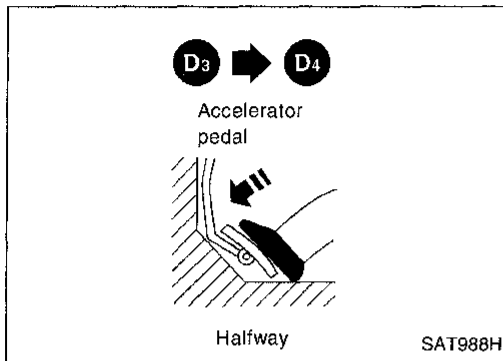

During "Cruise test - Part 1" (AT-32), does A/T shift from D<sub>3</sub> to D<sub>4</sub> at the specified speed?

Yes → Go to ② (AT-86) and check for proper lock-up.

No → Perform pressure test. Refer to AT-112.

NG → Go to ① (AT-85).

OK →

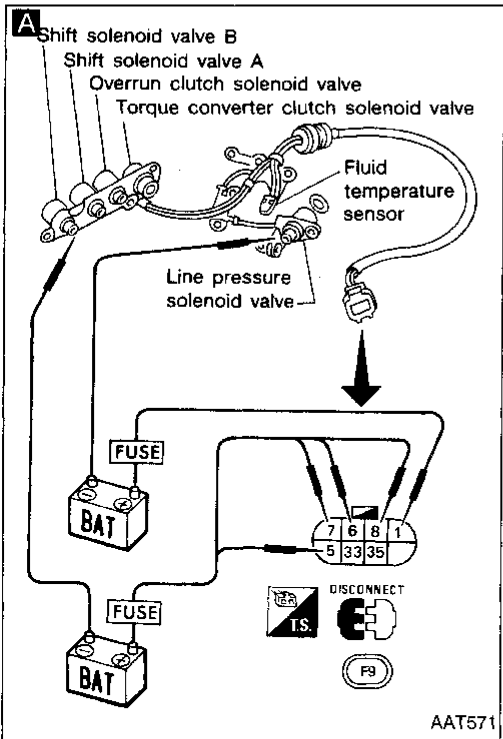

**A**  
**CHECK SOLENOID VALVES.**  
1. Remove control valve assembly. Refer to AT-124.  
2. Check solenoid valve assembly operation. Refer to AT-106.

NG → Replace solenoid valve assembly.

OK →

**B**  
**CHECK CONTROL VALVE.**  
1. Disassemble control valve assembly. Refer to AT-153.  
2. Check to ensure that:

- Valve, sleeve and plug slide along valve bore under their own weight.
- Valve, sleeve and plug are free from burrs, dents and scratches.
- Control valve springs are free from damage, deformation and fatigue.
- Hydraulic line is free from obstacles.

NG → Repair control valve.

OK →

Does A/T shift from D<sub>3</sub> to D<sub>4</sub> at the specified speed?

NG → Check control valve again. Repair or replace control valve assembly.

OK → Perform "Overall function check procedure", AT-83.

NG → Go to ② (AT-86) and check for proper lock-up.

OK → **INSPECTION END**

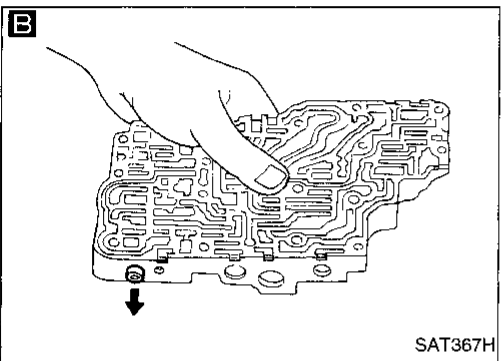

# TROUBLE DIAGNOSES

## Self-diagnosis (Cont'd)

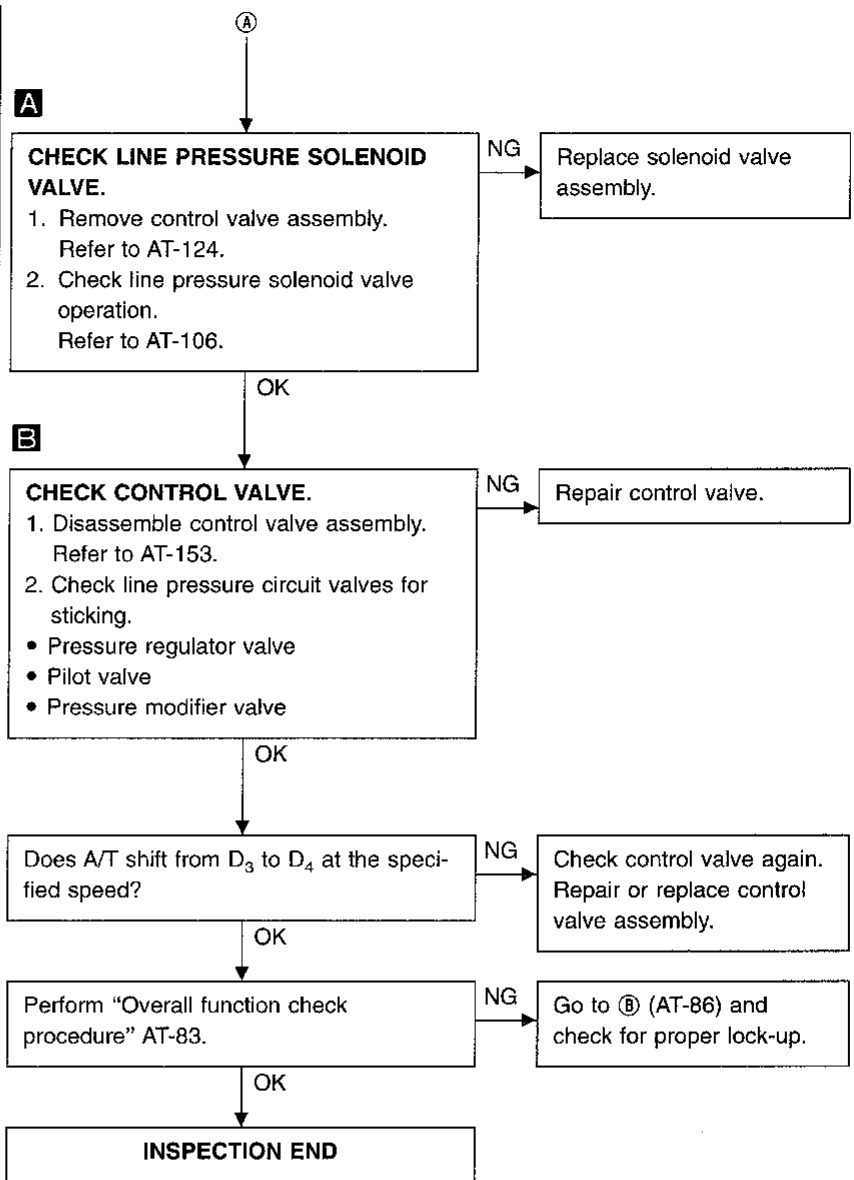
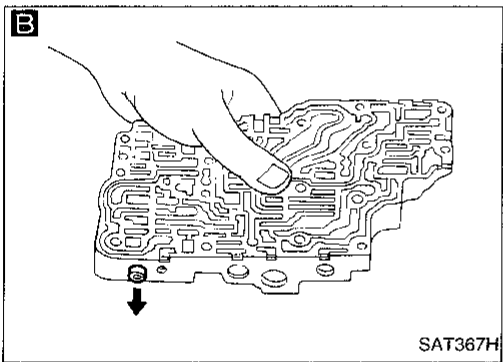
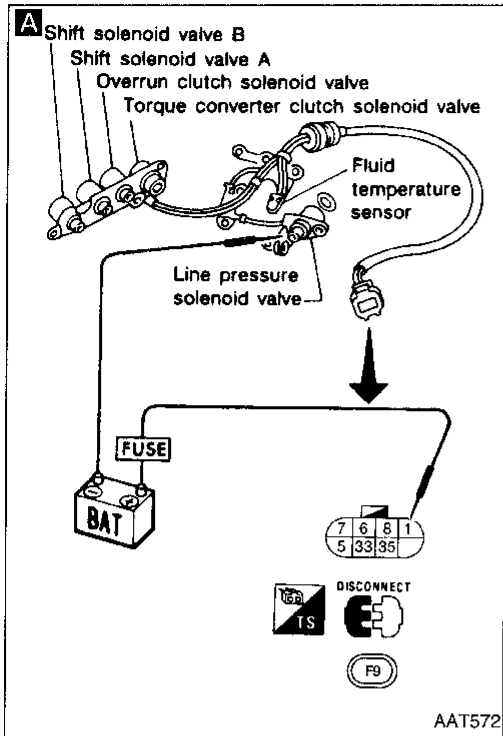

GI

MA

EM

LC

EC

FE

CL

MT

AT

FA

RA

BR

ST

RS

BT

HA

EL

IDX

# TROUBLE DIAGNOSES

## Self-diagnosis (Cont'd)

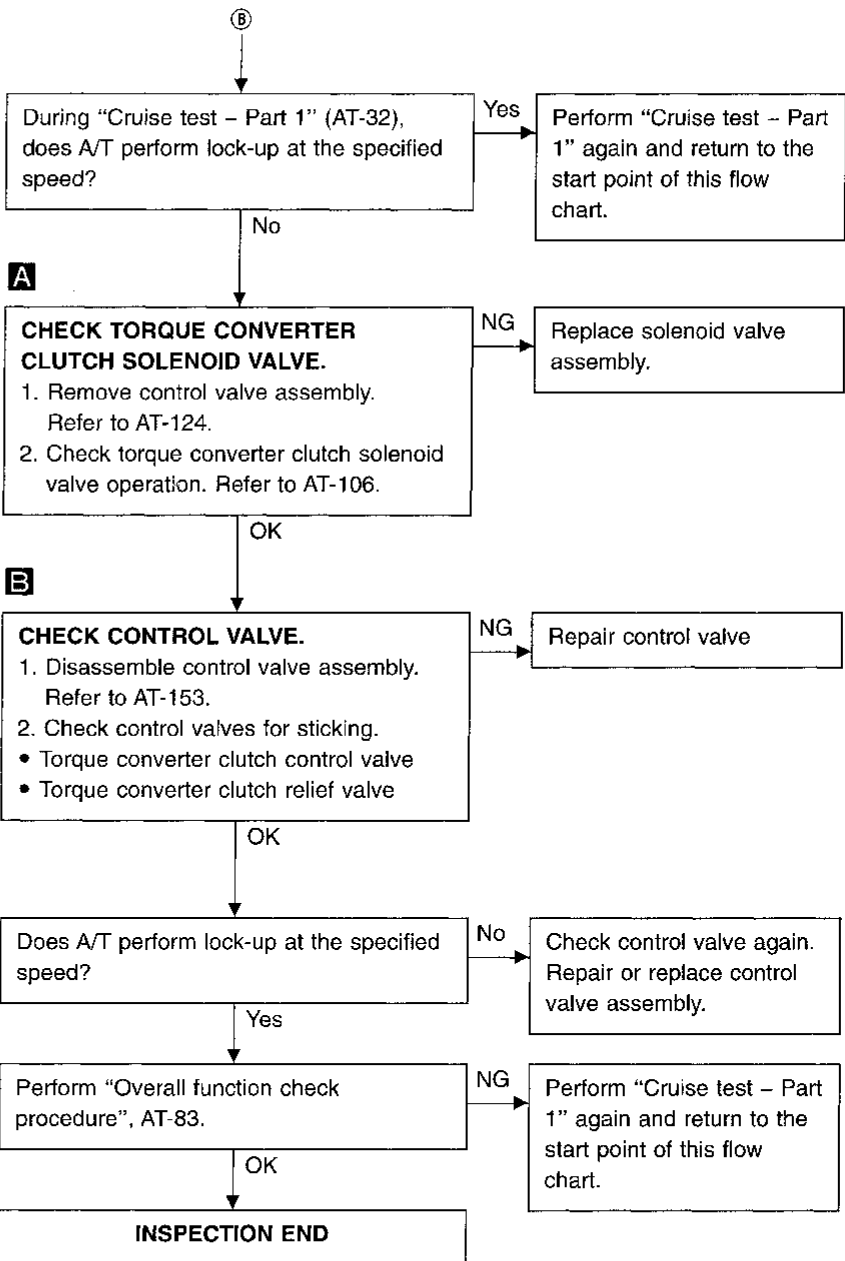
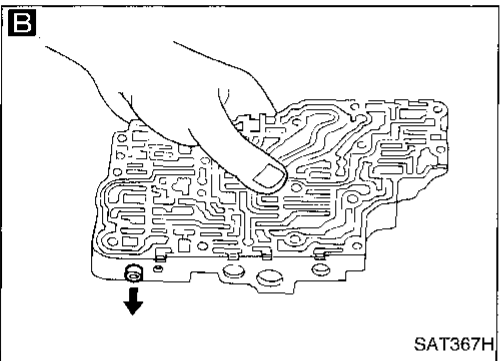
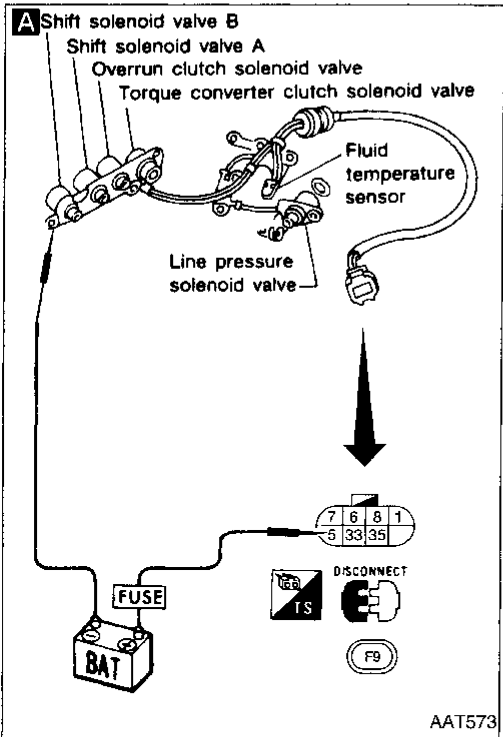
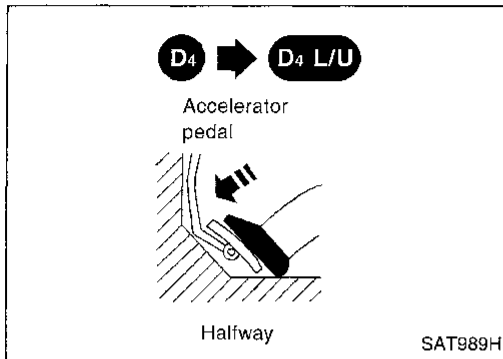

## Diagnostic Procedure 1

### SYMPTOM:

**OD OFF indicator lamp does not come on for about 2 seconds when turning ignition switch to "ON".**

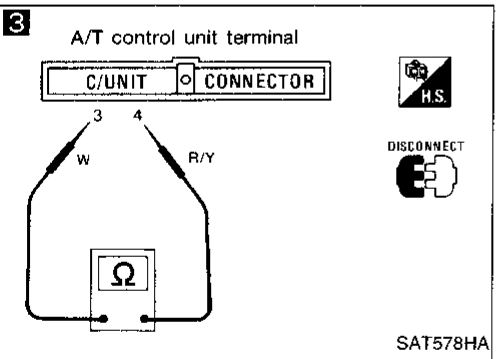
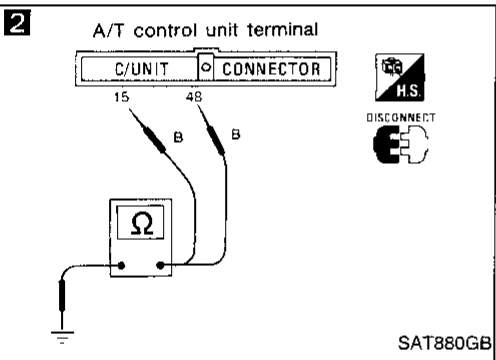
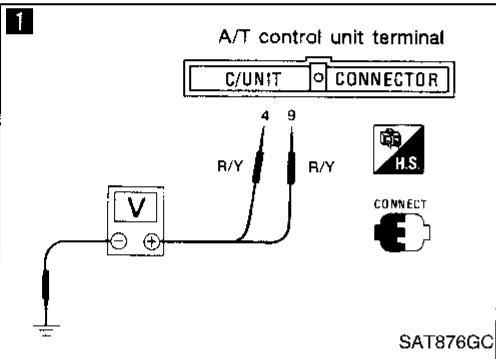
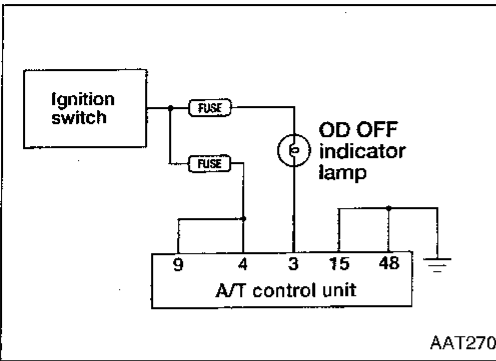

**1**

**CHECK A/T CONTROL UNIT POWER SOURCE.**

- Turn ignition switch to "ON" position. (Do not start engine.)
- Check voltage between A/T control unit terminals ④, ⑨ and ground. **Battery voltage should exist.**

OK

Check the following items:

- Harness for short or open between ignition switch and A/T control unit (Main harness)
- Ignition switch and fuse Refer to EL section ("POWER SUPPLY ROUTING").

**2**

**CHECK A/T CONTROL UNIT GROUND CIRCUIT.**

- Turn ignition switch to "OFF" position.
- Disconnect A/T control unit harness connector.
- Check resistance between A/T control unit terminals ⑮, ④ and ground. **Resistance: Approximately 0Ω**

OK

Check harness for short or open between A/T control unit and ground.

**3**

**CHECK LAMP CIRCUIT.**

- Turn ignition switch to "OFF" position.
- Check resistance between A/T control unit terminals ③ and ④. **Resistance: 50 - 100Ω**
- Reinstall any part removed.

OK

Check the following items.

- OD OFF indicator lamp (Refer to EL section.)
- Harness for short or open between Ignition switch and OD OFF indicator lamp (Main harness)
- Harness for short or open between OD OFF indicator lamp and A/T control unit

OK

1. Perform A/T control unit input/output signal inspection.

2. If NG, recheck A/T control unit pin terminals for damage or loose connection with harness connector.

OK

Check again.

OK

**INSPECTION END**

OK

Check again.

OK

1. Perform A/T control unit input/output signal inspection.

2. If NG, recheck A/T control unit pin terminals for damage or loose connection with harness connector.

GI  
MA  
EM  
LC  
EC  
FE  
CL  
MT  
**AT**  
FA  
RA  
BR  
ST  
RS  
BT  
HA  
EL  
IDX

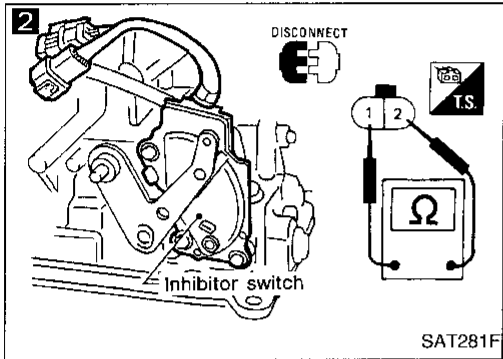
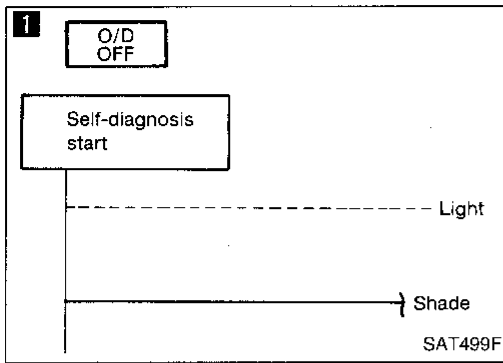

## Diagnostic Procedure 2

### SYMPTOM:

- Engine cannot be started with selector lever in "P" or "N" position.
- Engine can be started with selector lever in "D", "2", "1" or "R" position.

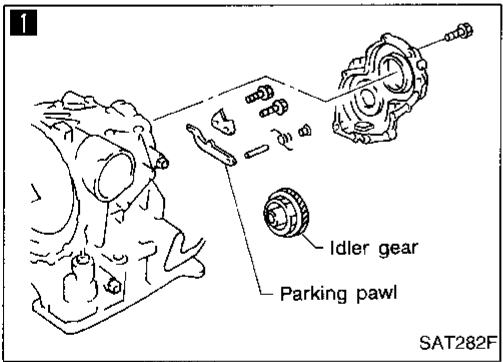
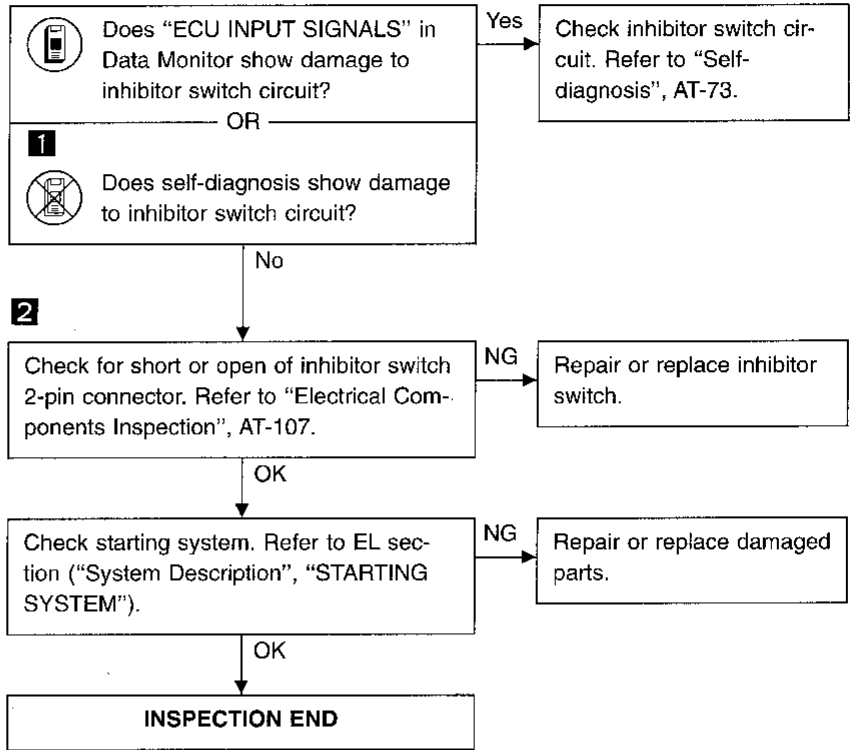

## Diagnostic Procedure 3

### SYMPTOM:

Vehicle moves when it is pushed forward or backward with selector lever in "P" position.

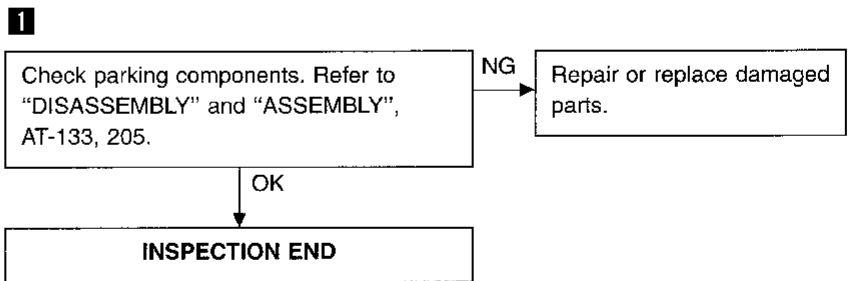



# TROUBLE DIAGNOSES

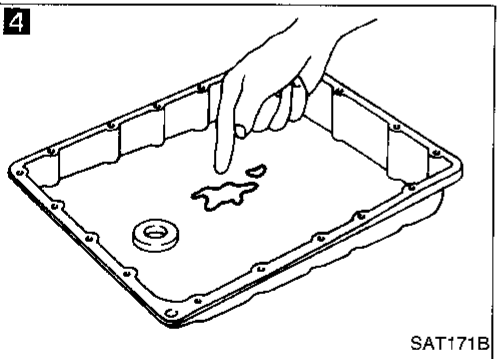
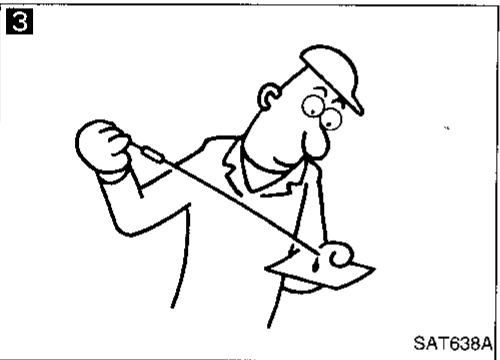
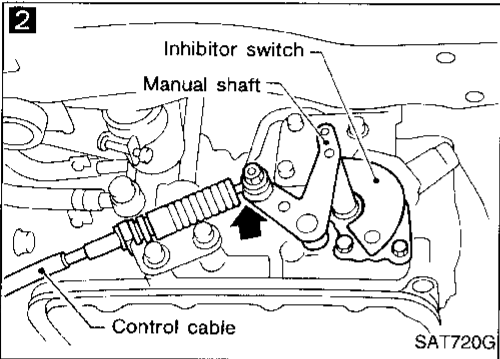
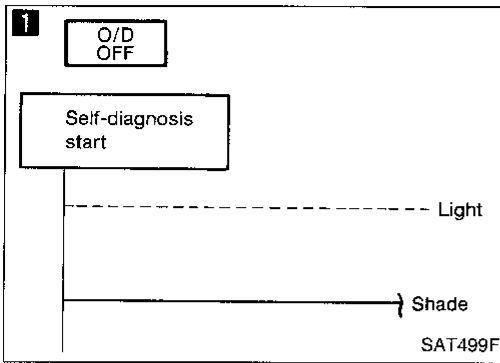

## Diagnostic Procedure 4

### SYMPTOM:

Vehicle moves forward or backward when selecting "N" position.

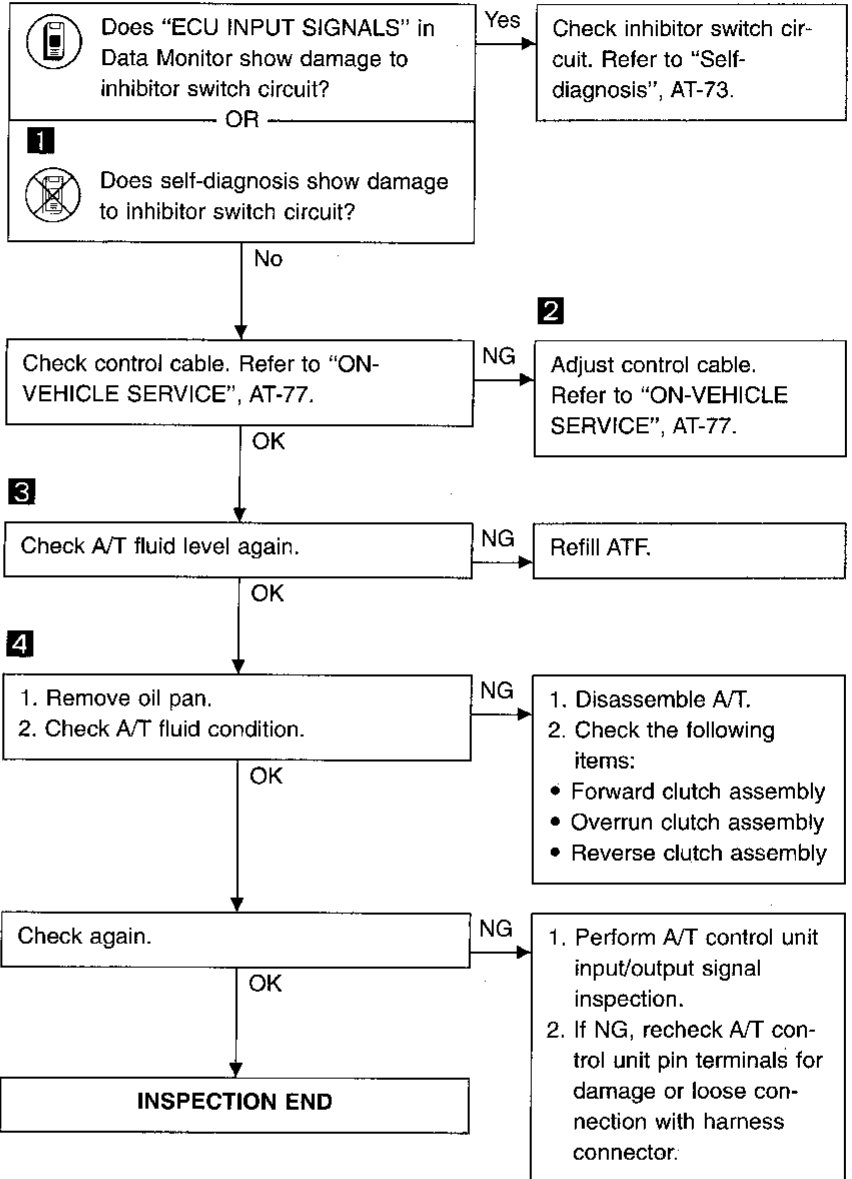

GI  
MA  
EM  
LC  
EC  
FE  
CL  
MT  
AT  
FA  
RA  
BR  
ST  
RS  
BT  
HA  
EL  
IDX

## Diagnostic Procedure 5

### SYMPTOM:

**There is large shock when changing from "N" to "R" position.**

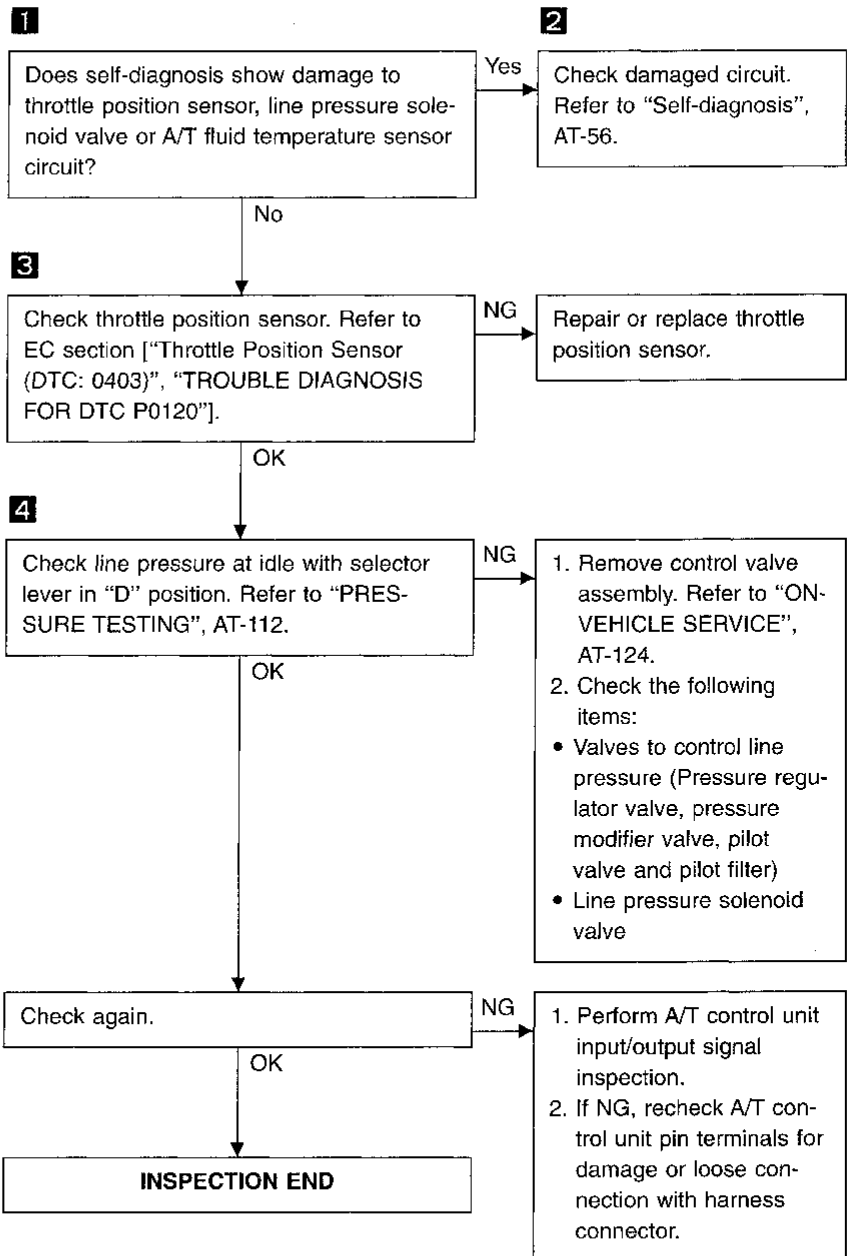
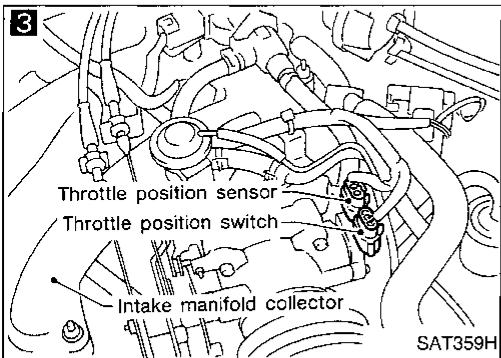
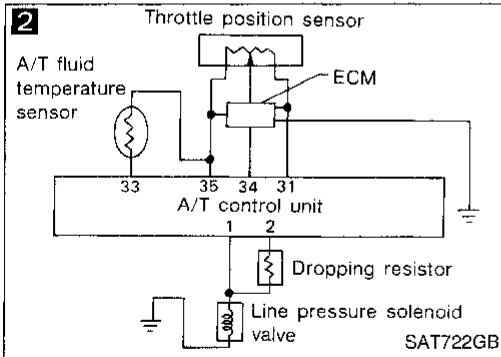
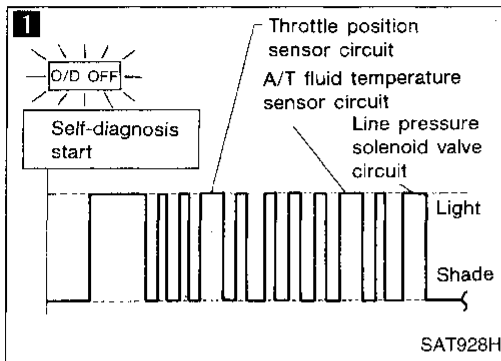

# TROUBLE DIAGNOSES

## Diagnostic Procedure 6

### SYMPTOM:

Vehicle does not creep backward when selecting "R" position.

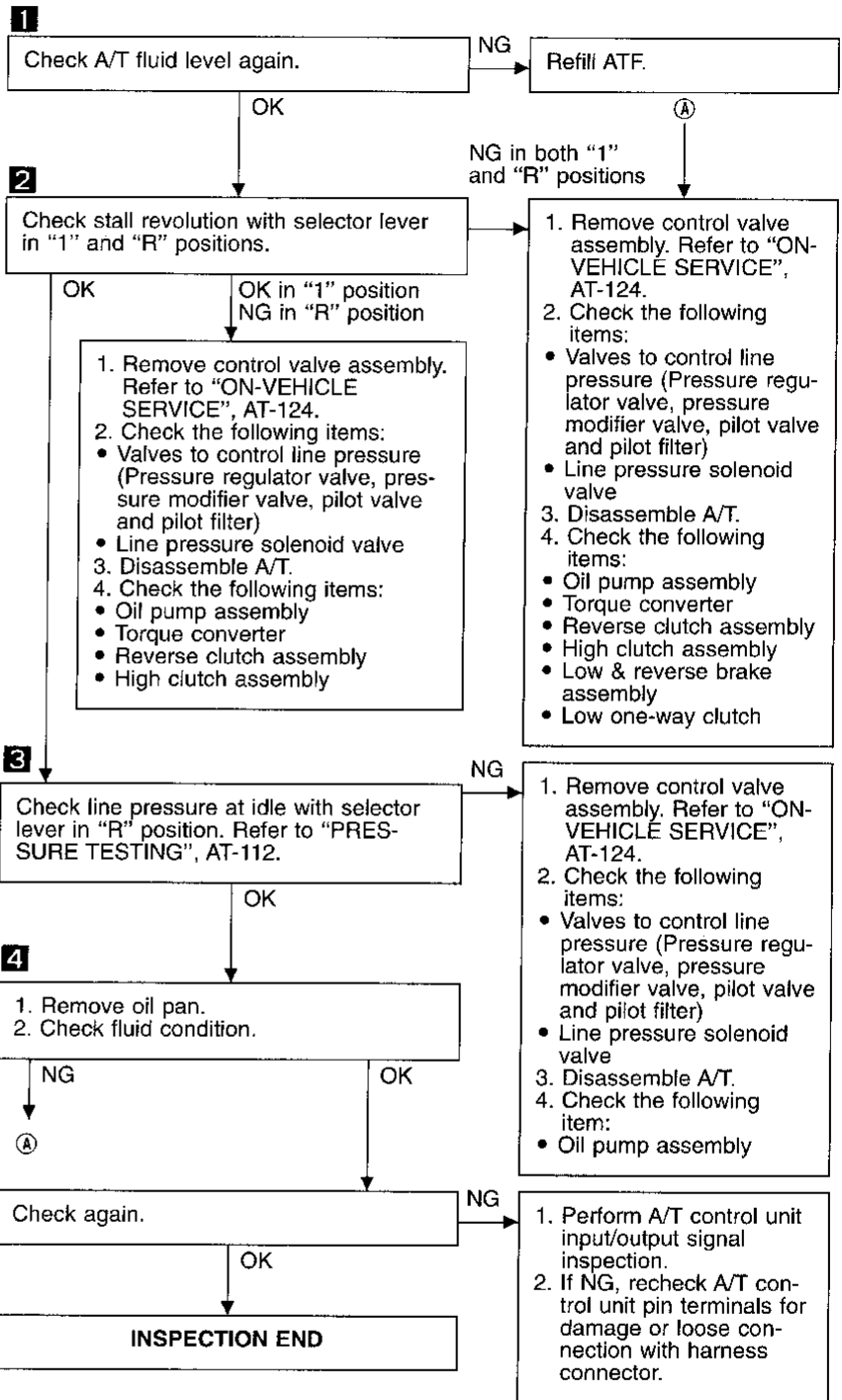
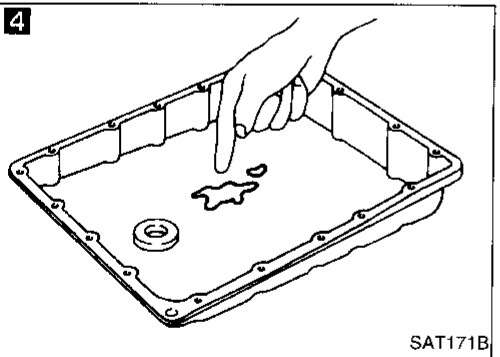
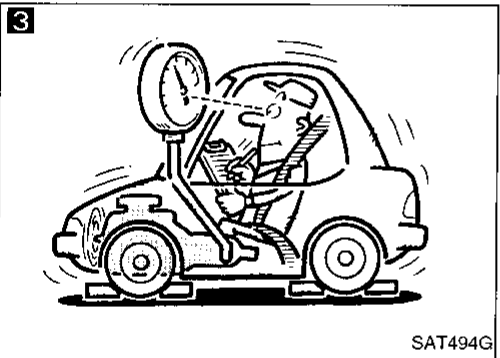
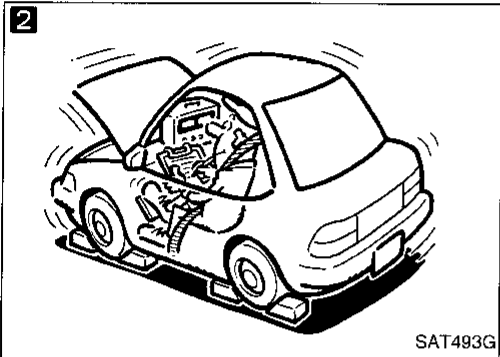
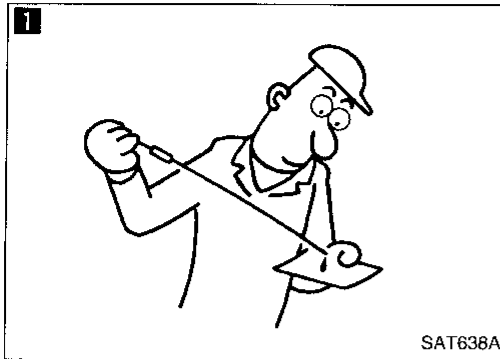

GI  
MA  
EM  
LC  
EC  
FE  
CL  
MT  
AT  
FA  
RA  
BR  
ST  
RS  
BT  
JA  
EL  
IDX

# TROUBLE DIAGNOSES

## Diagnostic Procedure 7

### SYMPTOM:

Vehicle does not creep forward when selecting "D", "2" or "1" position.

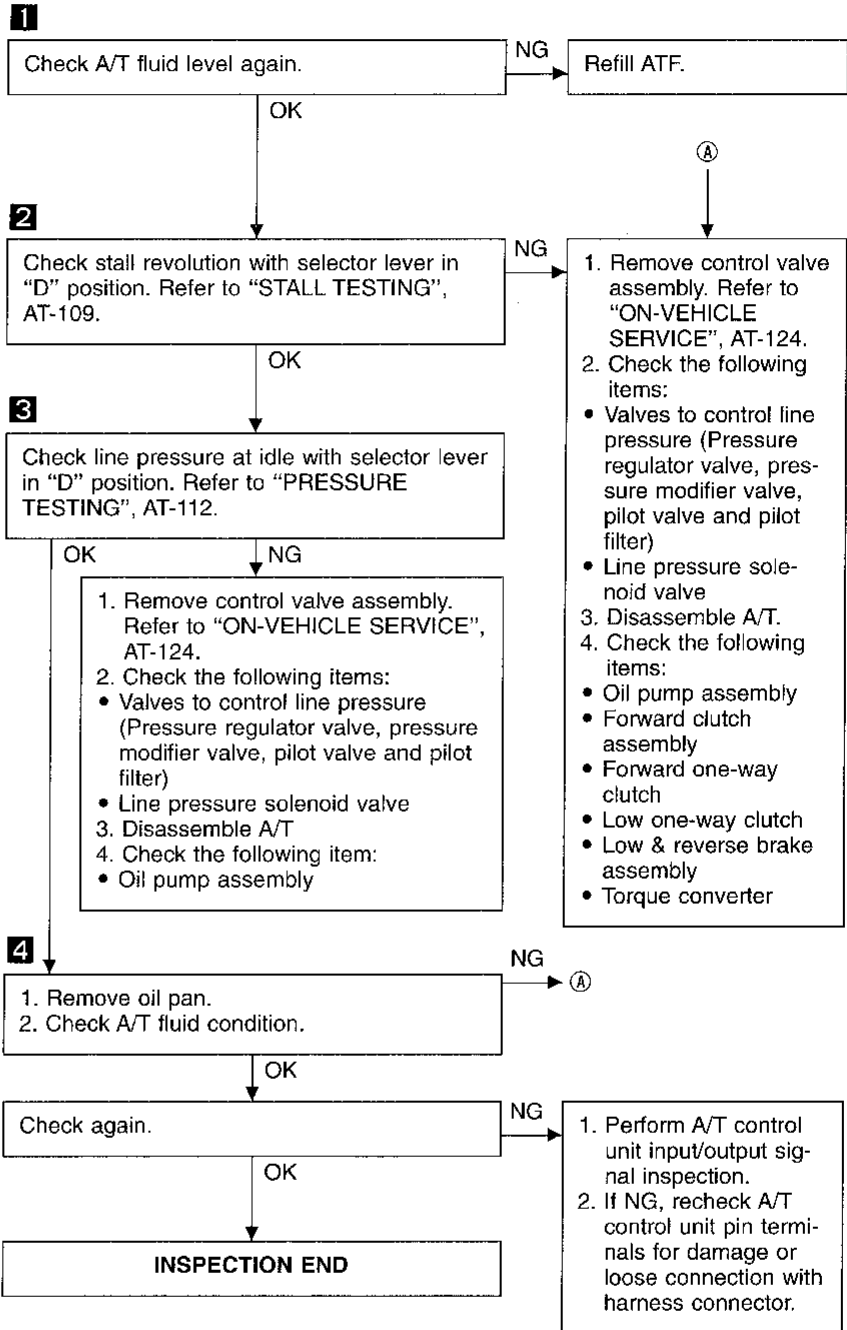
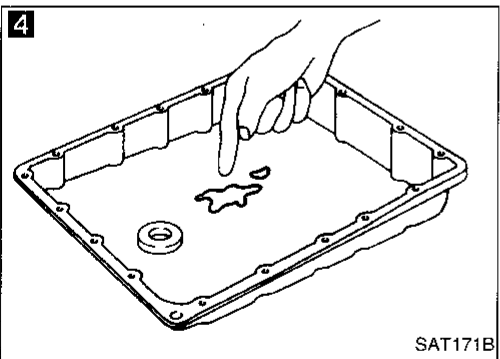
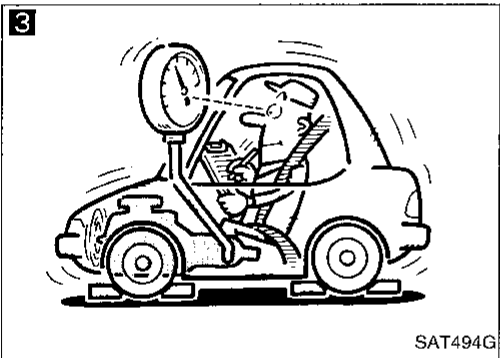
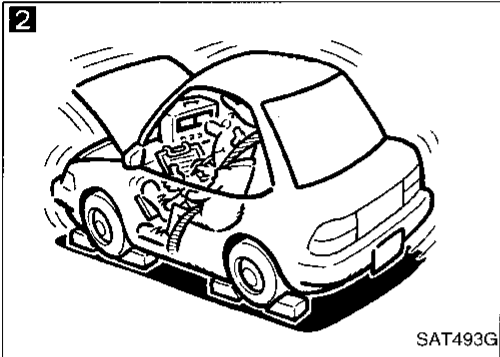
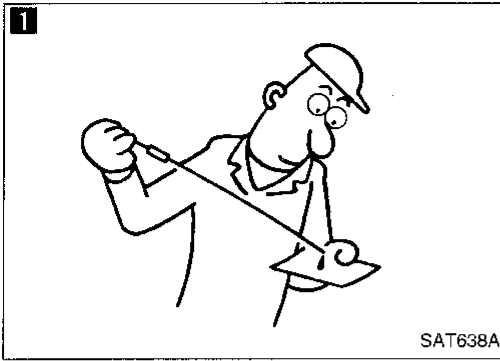

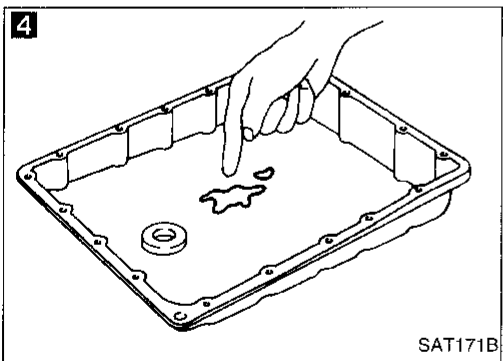
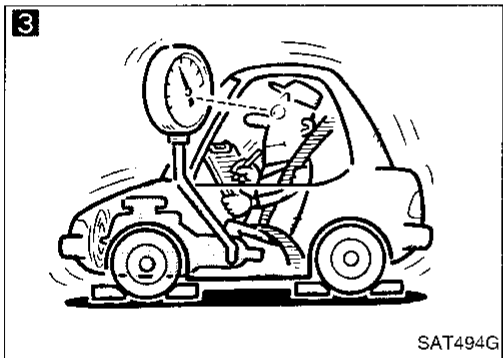
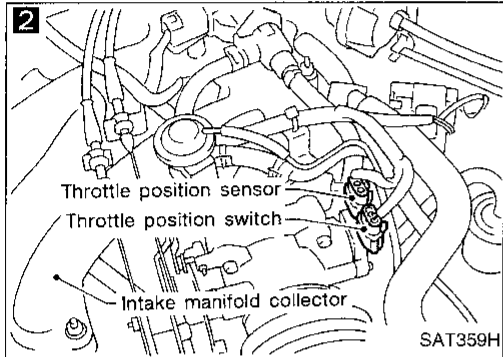
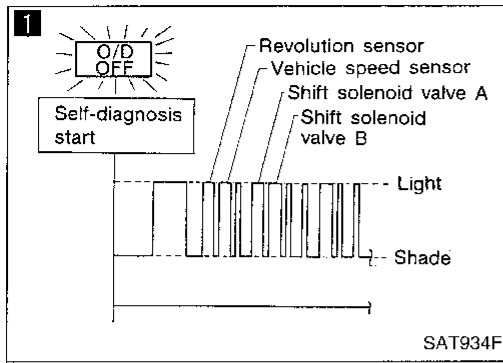

## Diagnostic Procedure 8

### SYMPTOM:

**Vehicle cannot be started from D<sub>1</sub> on Cruise test — Part 1.**

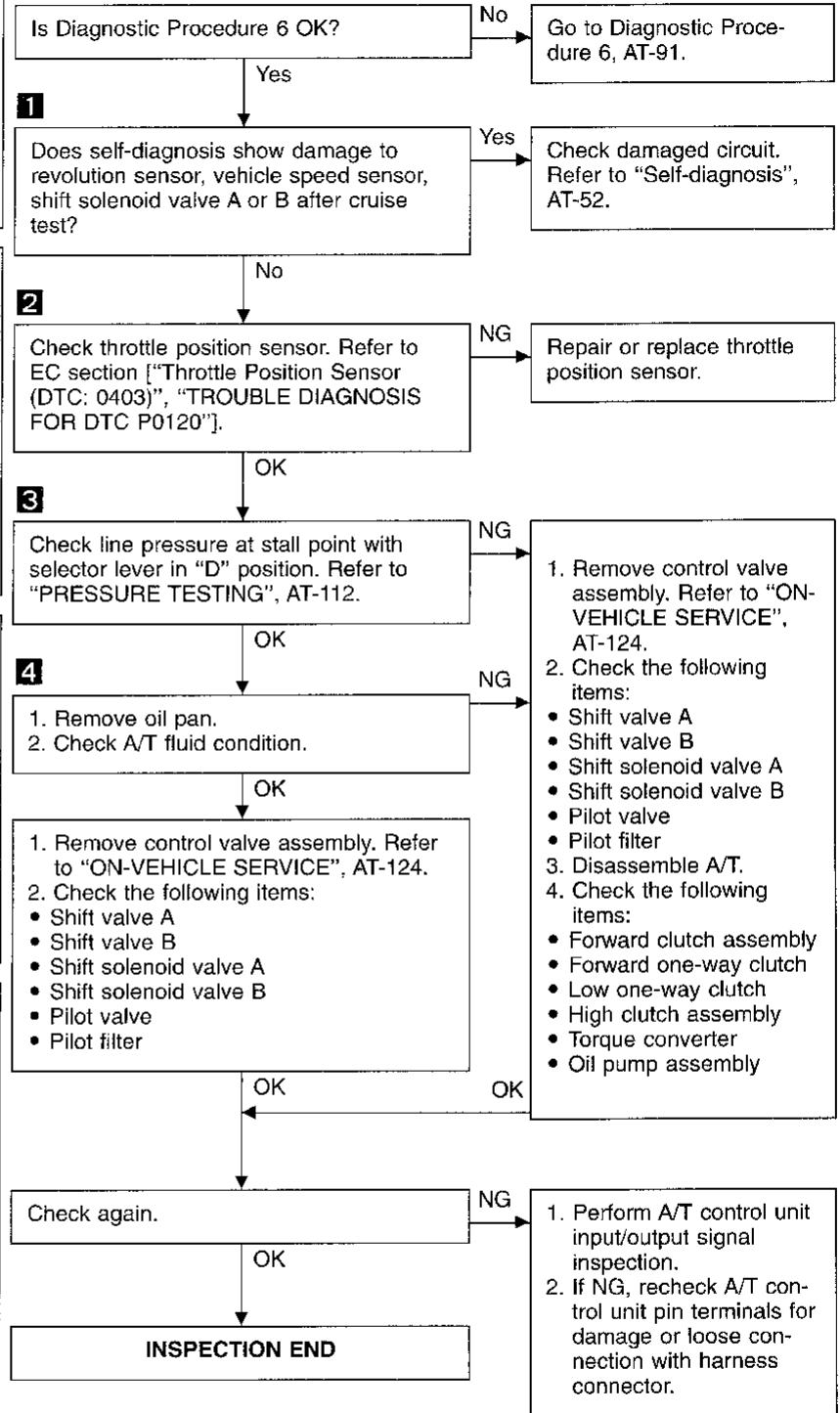

GI

MA

EM

LC

EC

FE

CL

MT

AT

FA

RA

BR

ST

RS

BT

HA

EL

IDX

# TROUBLE DIAGNOSES

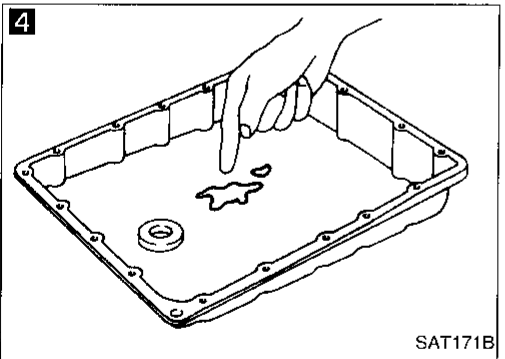
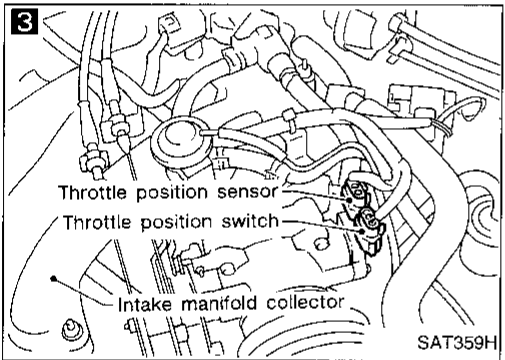
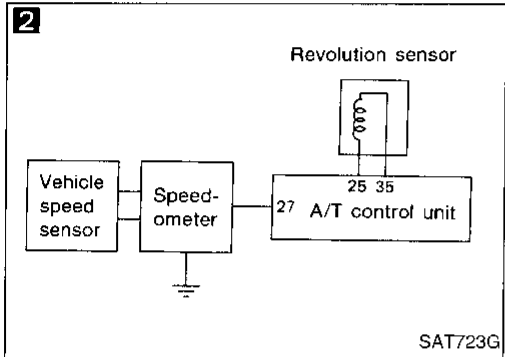
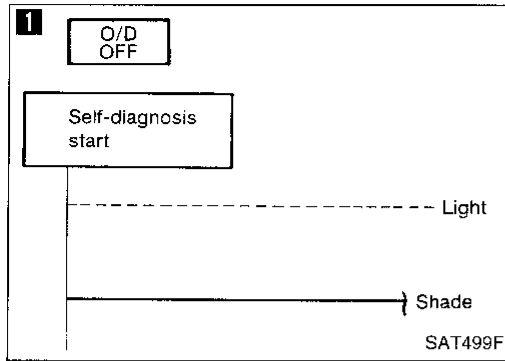

## Diagnostic Procedure 9

### SYMPTOM:

A/T does not shift from  $D_1$  to  $D_2$  at the specified speed.

A/T does not shift from  $D_4$  to  $D_2$  when depressing accelerator pedal fully at the specified speed.

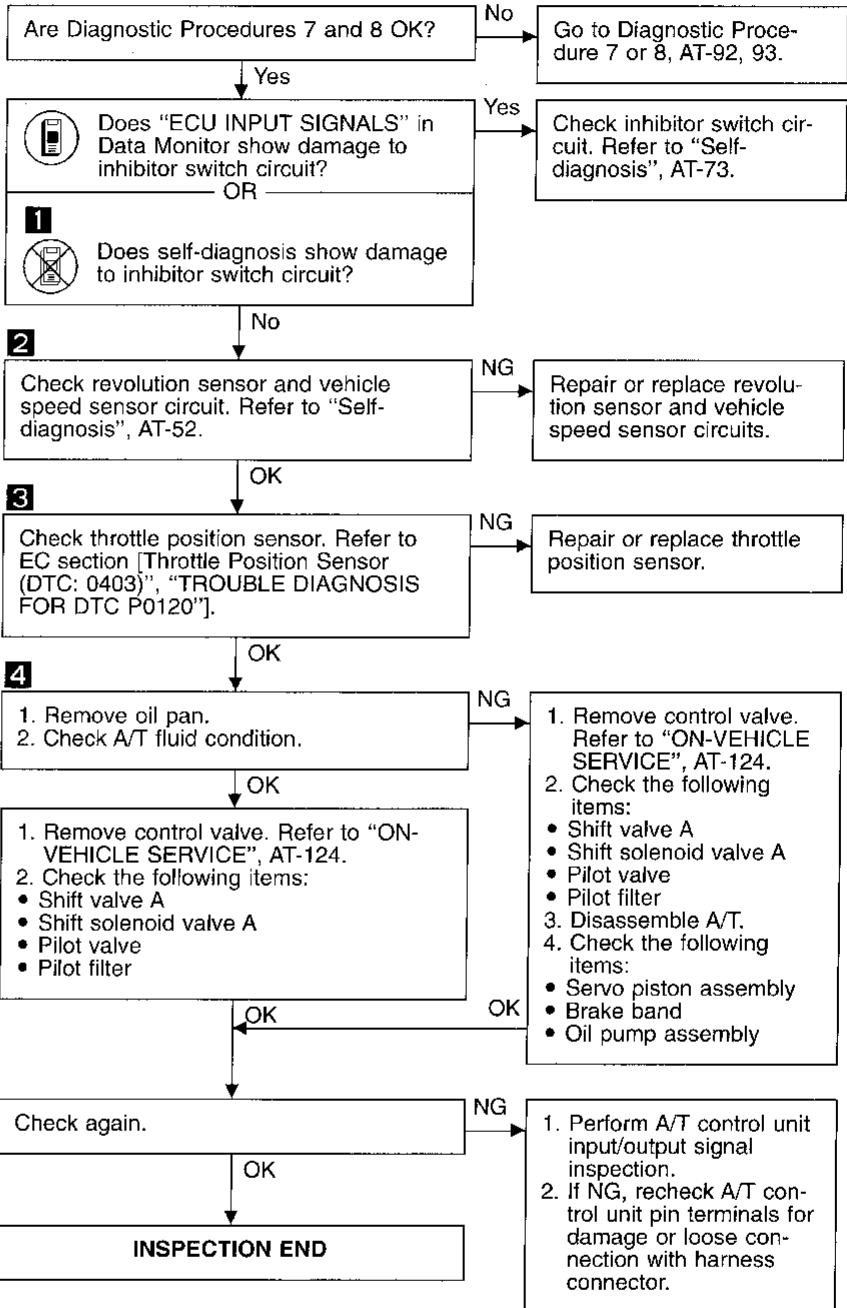

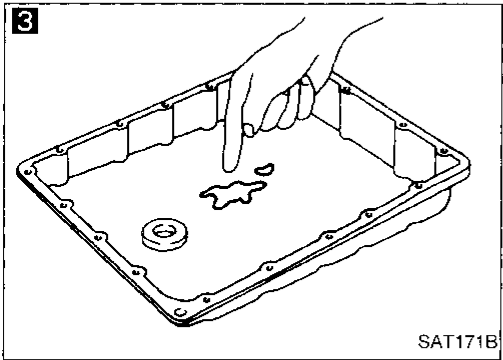
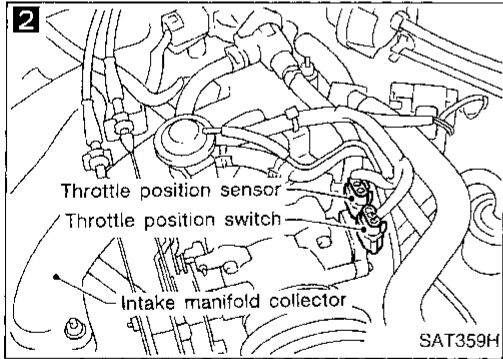
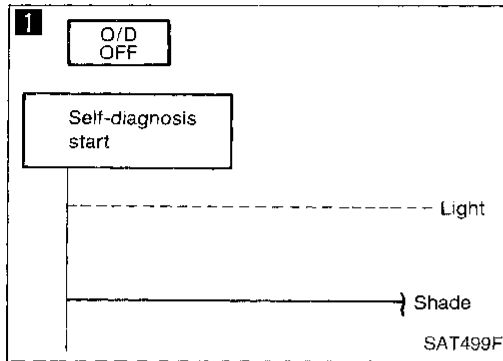

## Diagnostic Procedure 10

### SYMPTOM:

**A/T does not shift from D<sub>2</sub> to D<sub>3</sub> at the specified speed.**

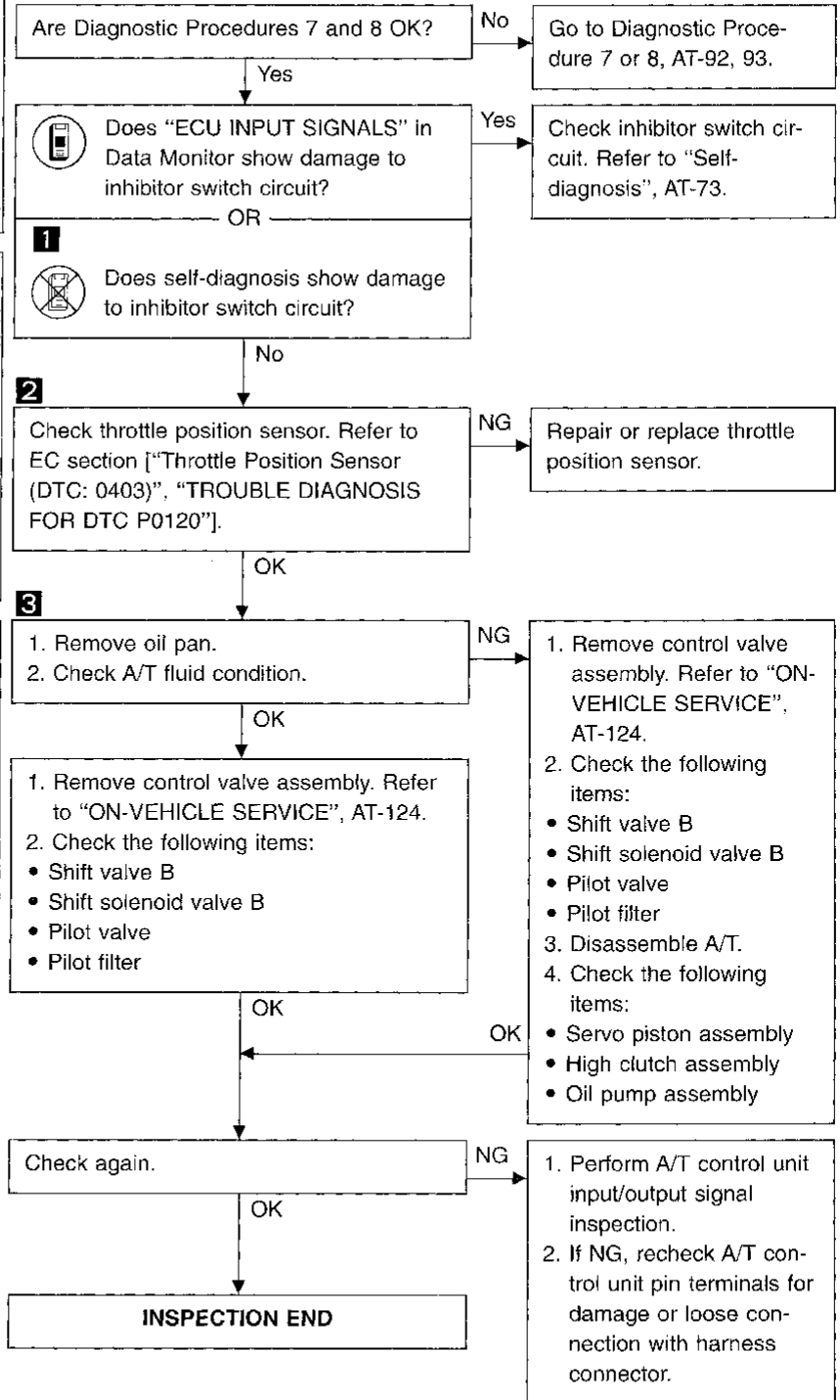

GI

MA

EM

LC

EC

FE

CL

WT

AT

FA

RA

BR

ST

RS

BT

HA

EL

IDX

# TROUBLE DIAGNOSES

## Diagnostic Procedure 11

### SYMPTOM:

**A/T does not shift from D<sub>3</sub> to D<sub>4</sub> at the specified speed.  
A/T must be warm before D<sub>3</sub> to D<sub>4</sub> shift will occur.**

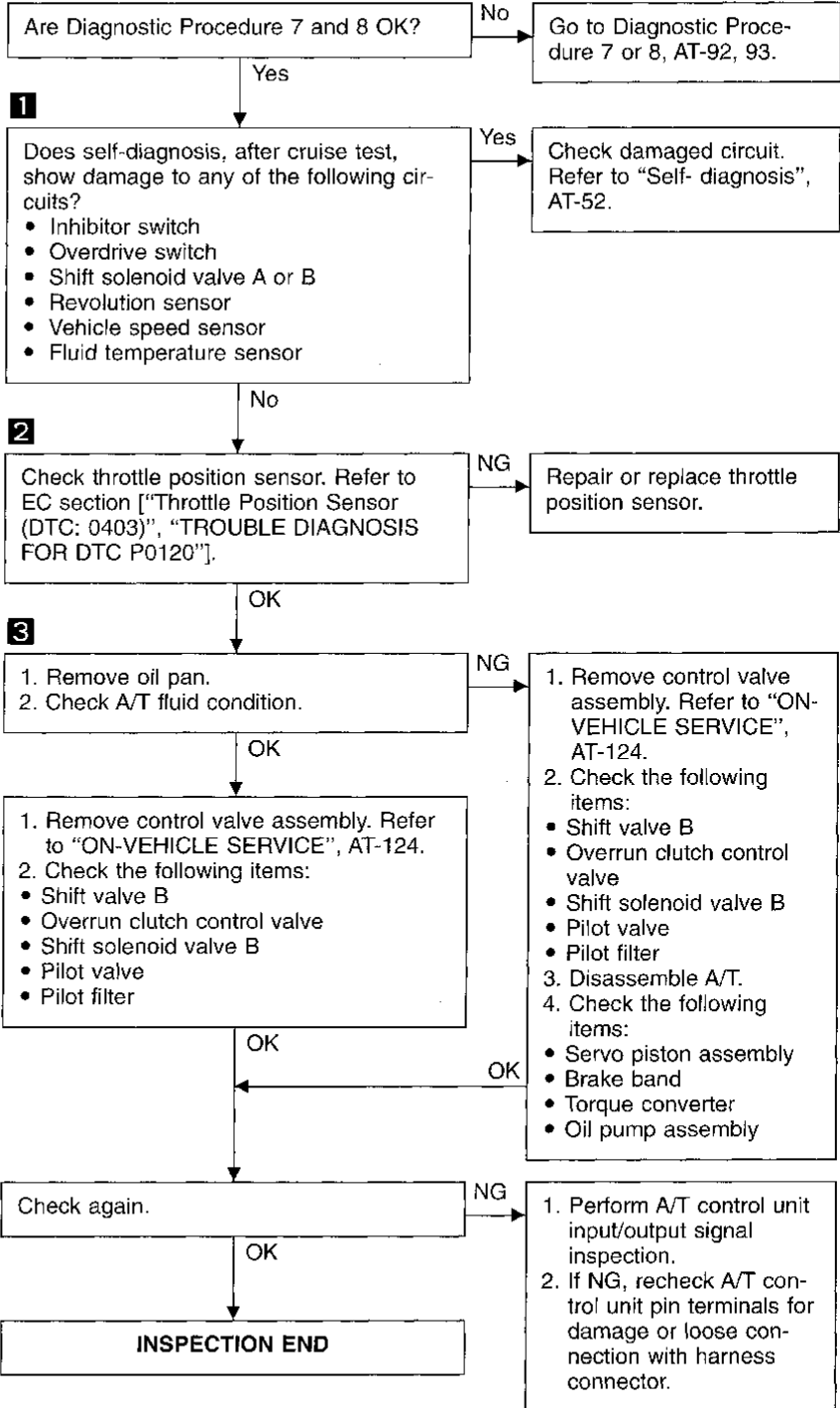
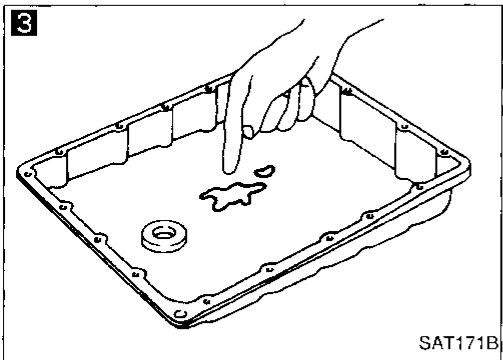
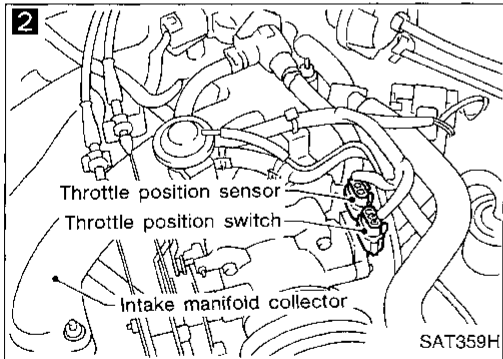
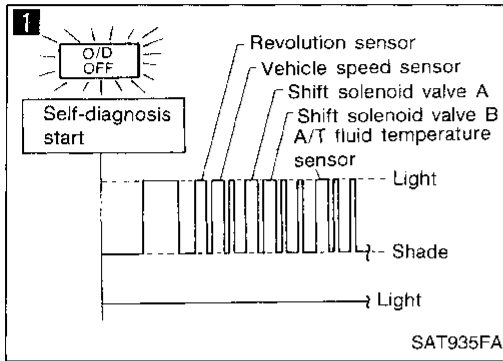



# TROUBLE DIAGNOSES

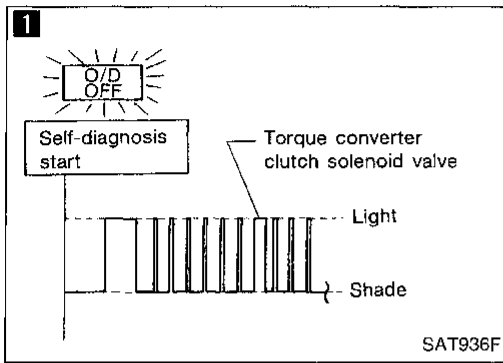

## Diagnostic Procedure 12

### SYMPTOM:

**A/T does not perform lock-up at the specified speed.**

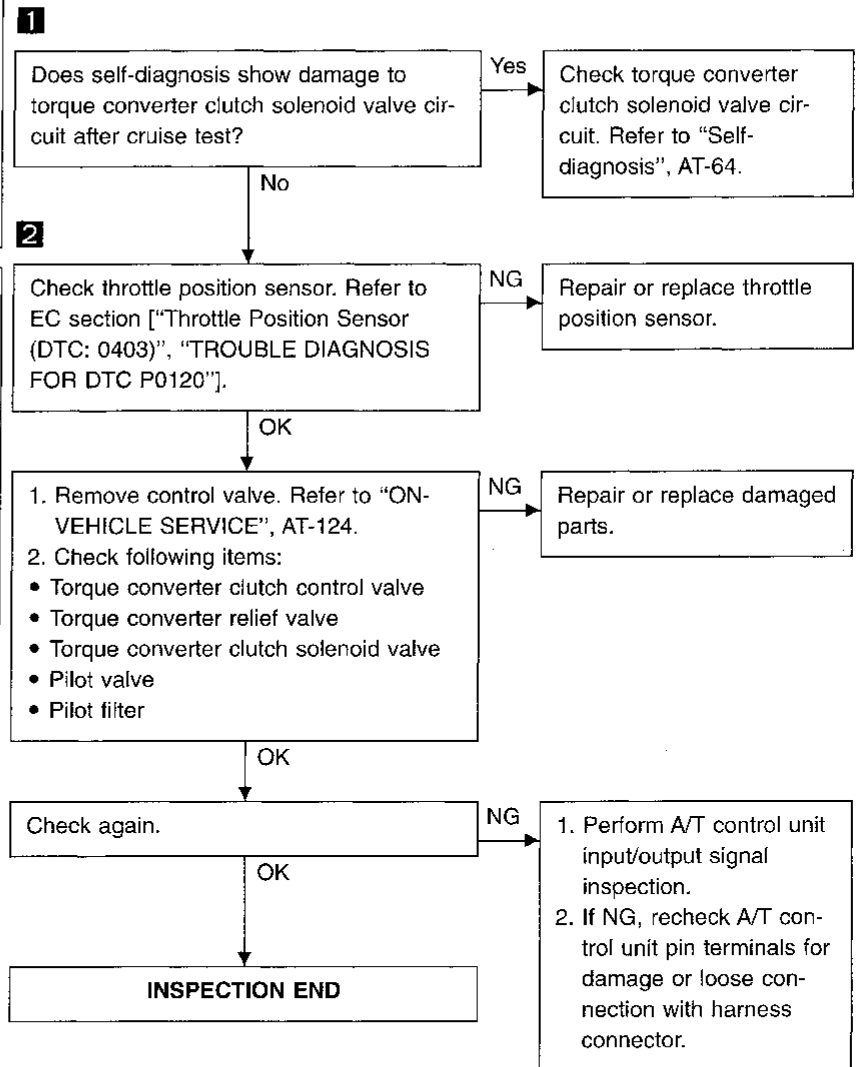
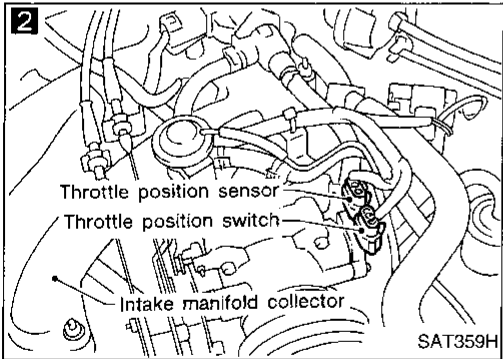

GI  
 MA  
 EM  
 LC  
 EC  
 FE  
 CL  
 MT  
**AT**  
 FA  
 RA  
 BR  
 ST  
 RS  
 BT  
 HA  
 EL  
 IDX

# TROUBLE DIAGNOSES

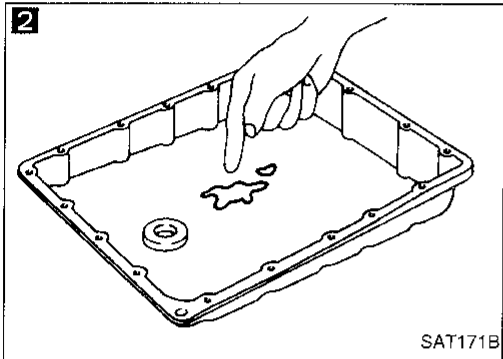
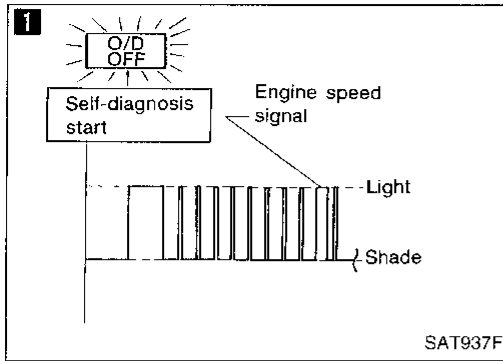

## Diagnostic Procedure 13

### SYMPTOM:

**A/T does not hold lock-up condition for more than 30 seconds.**

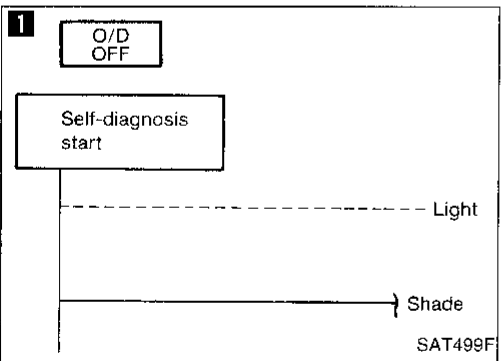
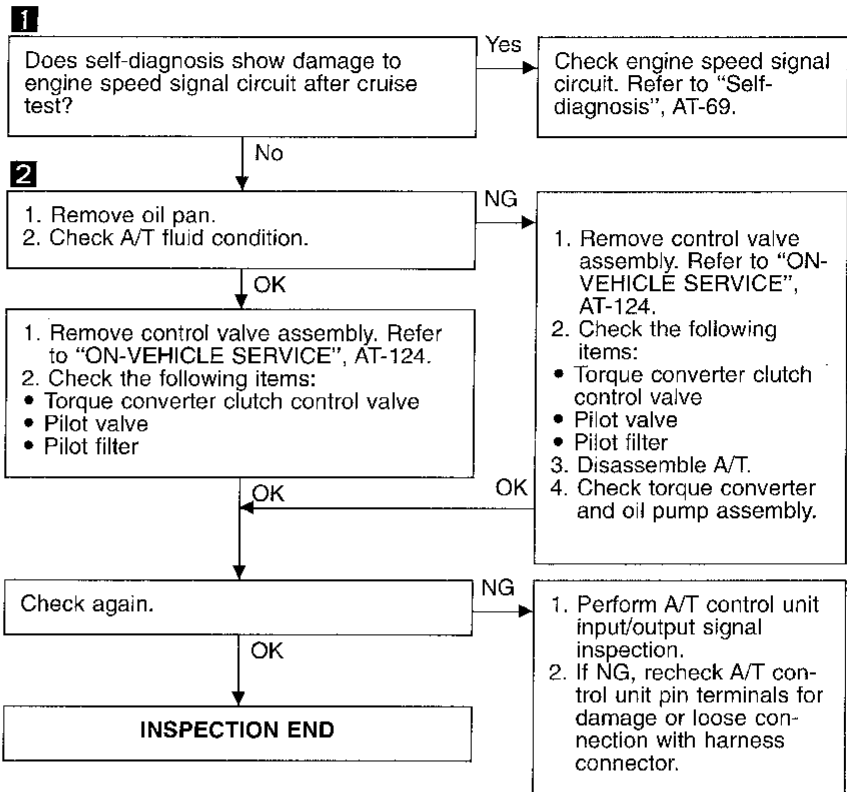

## Diagnostic Procedure 14

### SYMPTOM:

**Lock-up is not released when accelerator pedal is released.**

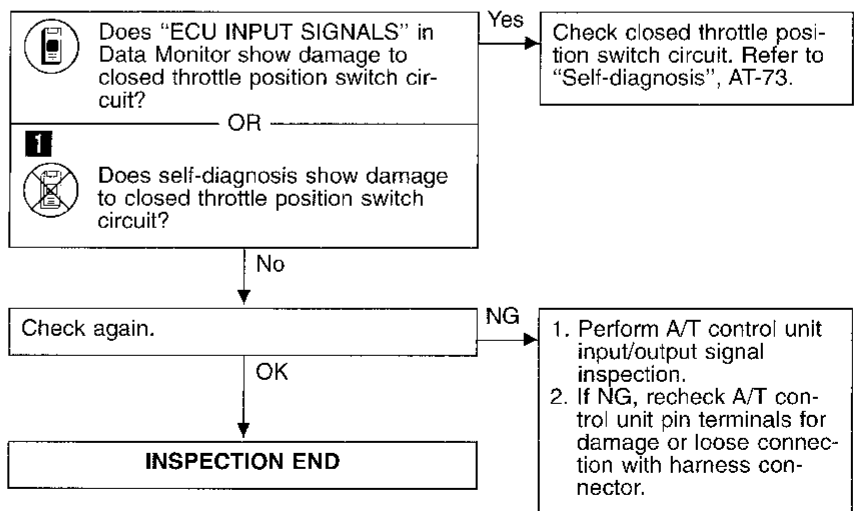

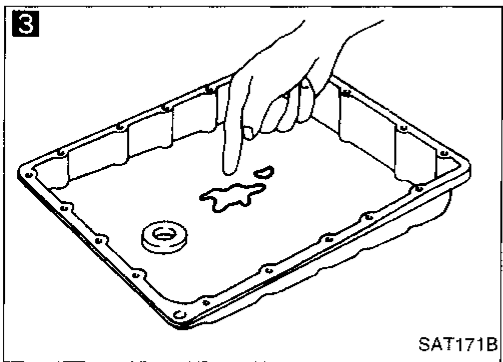
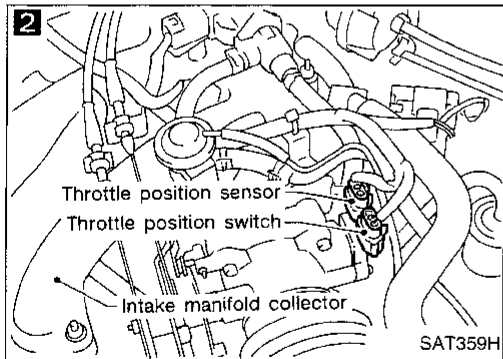
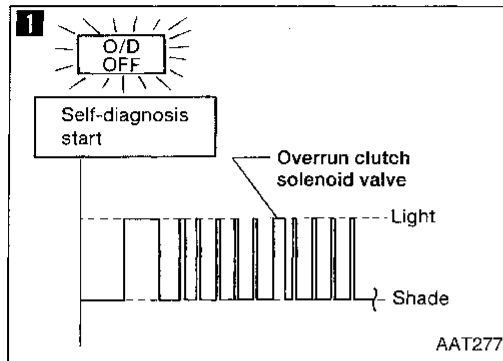

## Diagnostic Procedure 15

### SYMPTOM:

With accelerator pedal released:

- Engine speed does not smoothly return to idle when A/T shifts from D<sub>4</sub> to D<sub>3</sub>.
- Vehicle does not decelerate by engine brake when turning overdrive switch OFF.
- Vehicle does not decelerate by engine brake when changing selector lever from "D" to "2" position.

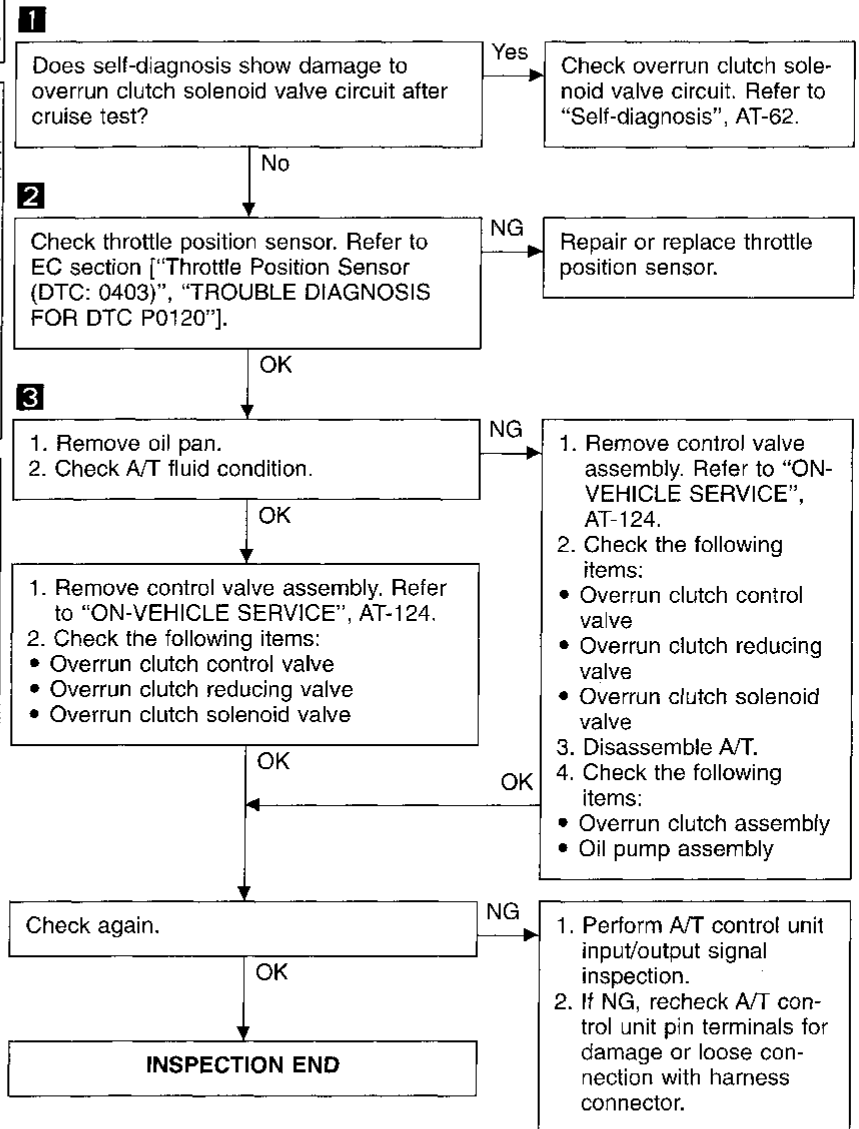

GI

MA

EM

LC

EC

FE

CL

MT

AT

FA

RA

BR

ST

RS

BT

HA

EL

IDX

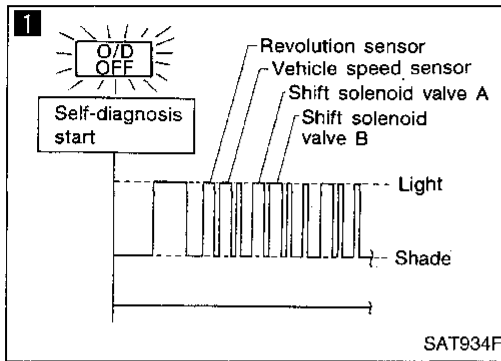

## Diagnostic Procedure 16

### SYMPTOM:

Vehicle does not start from D<sub>1</sub> on Cruise test — Part 2.

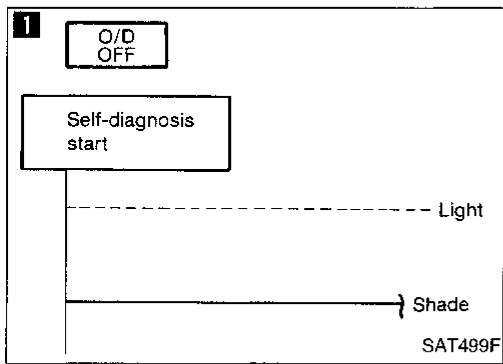
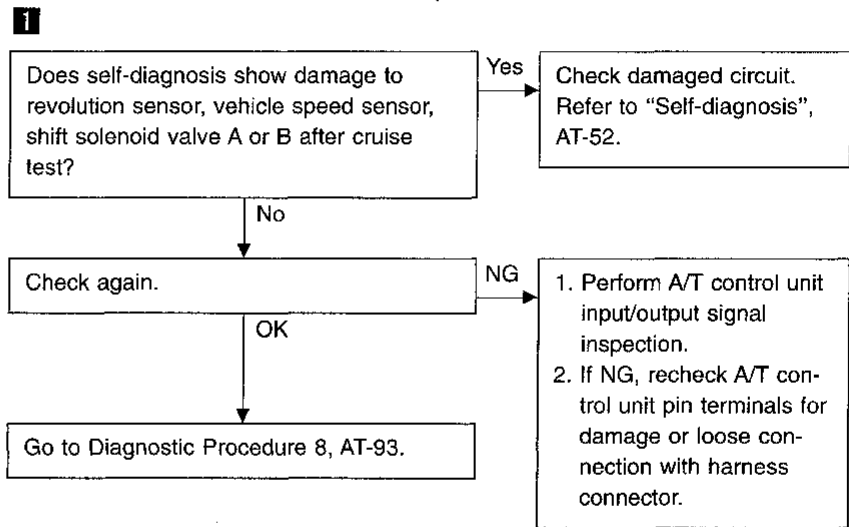

## Diagnostic Procedure 17

### SYMPTOM:

A/T does not shift from D<sub>4</sub> to D<sub>3</sub> when changing overdrive switch to "OFF" position.

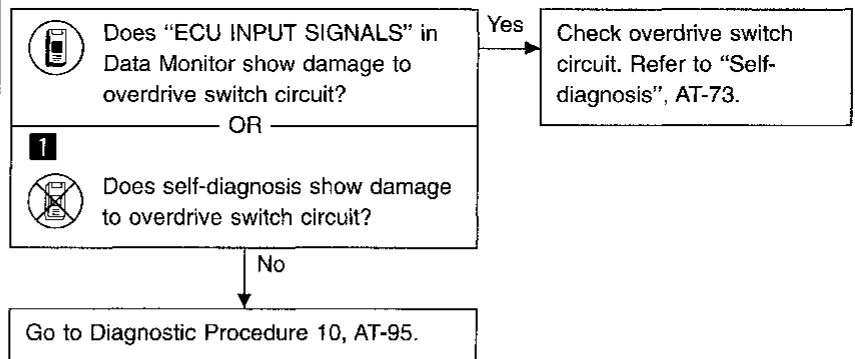

# TROUBLE DIAGNOSES

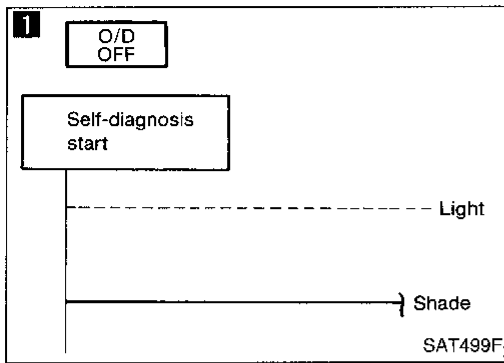

## Diagnostic Procedure 18

### SYMPTOM:

A/T does not shift from  $D_3$  to  $2_2$  when changing selector lever from "D" to "2" position.

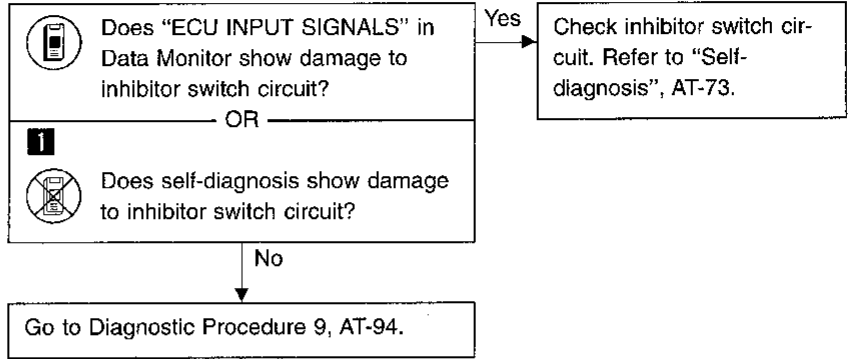

GI

MA

EM

LG

EC

FE

CL

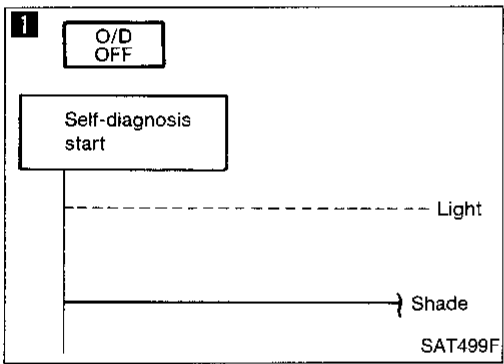

## Diagnostic Procedure 19

### SYMPTOM:

A/T does not shift from  $2_2$  to  $1_1$  when changing selector lever from "2" to "1" position.

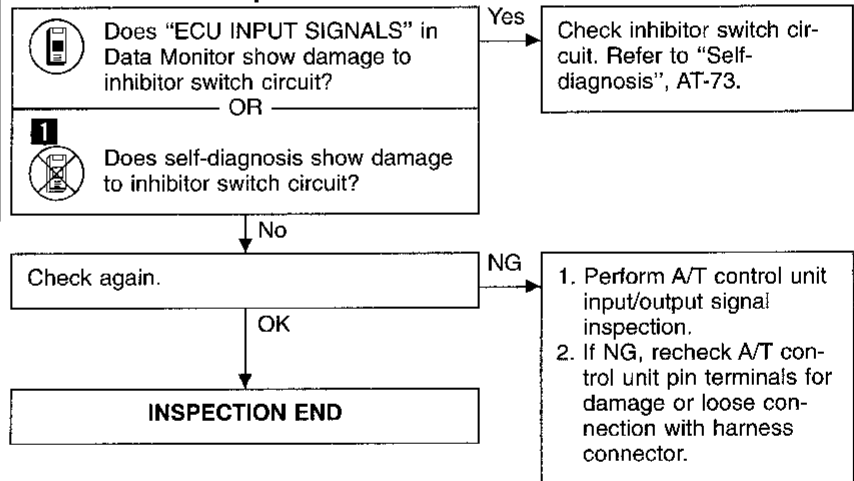

MT

AT

FA

RA

BR

ST

RS

BT

HA

EL

## Diagnostic Procedure 20

### SYMPTOM:

Vehicle does not decelerate by engine brake when shifting from  $2_2$  ( $1_2$ ) to  $1_1$ .

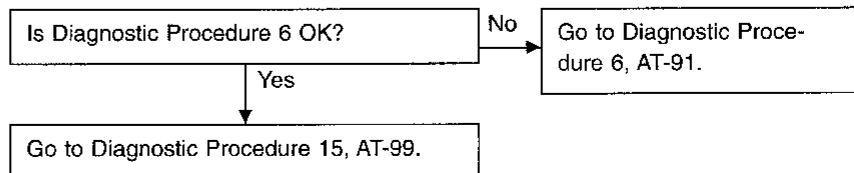

IDX

# TROUBLE DIAGNOSES

## Electrical Components Inspection

### INSPECTION OF A/T CONTROL UNIT

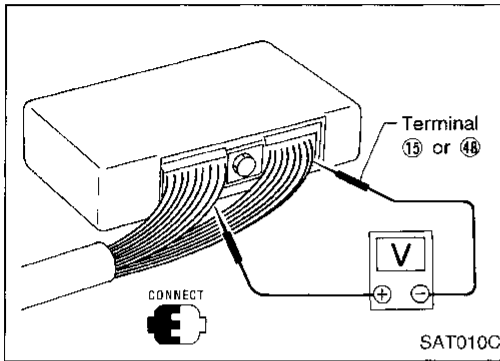

- Measure voltage between each terminal and terminal 15 or 48 by following "A/T CONTROL UNIT INSPECTION TABLE".
- Pin connector terminal layout

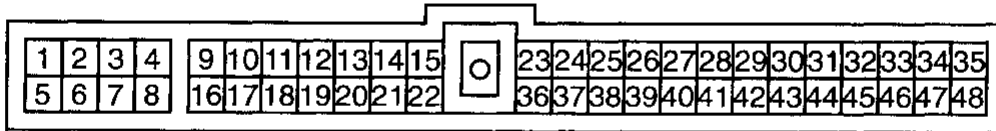

SAT925H

### A/T CONTROL UNIT INSPECTION TABLE

(Data are reference values.)

Terminal No.	Item		Condition	Judgement standard
1	Line pressure solenoid valve		When releasing accelerator pedal after warming up engine.	1.5 - 2.5V
			When depressing accelerator pedal fully after warming up engine.	0.5V or less
2	Line pressure solenoid valve (with dropping resistor)		When releasing accelerator pedal after warming up engine.	5 - 14V
			When depressing accelerator pedal fully after warming up engine.	0.5V or less
3	OD OFF indicator lamp		When setting overdrive switch in "ON" position.	Battery voltage
			When setting overdrive switch in "OFF" position.	1V or less
4	Power source		When turning ignition switch to "ON".	Battery voltage
			When turning ignition switch to "OFF".	1V or less

# TROUBLE DIAGNOSES







## Electrical Components Inspection (Cont'd)

Terminal No.	Item	Condition	Judgement standard
5	Torque converter clutch solenoid valve	When A/T performs lock-up.	8 - 15V
		When A/T does not perform lock-up.	1V or less
6	Shift solenoid valve A	When shift solenoid valve A operates. (When driving in "D <sub>1</sub> " or "D <sub>4</sub> ".)	Battery voltage
		When shift solenoid valve A does not operate. (When driving in "D <sub>2</sub> " or "D <sub>3</sub> ".)	1V or less
7	Shift solenoid valve B	When shift solenoid valve B operates. (When driving in "D <sub>1</sub> " or "D <sub>2</sub> ".)	Battery voltage
		When shift solenoid valve B does not operate. (When driving in "D <sub>3</sub> " or "D <sub>4</sub> ".)	1V or less
8	Overrun clutch solenoid valve	When overrun clutch solenoid valve operates.	Battery voltage
		When overrun clutch solenoid valve does not operate.	1V or less
9	Power source	Same as No. 4	
10*	DT1	—	—
11*	DT2	—	—
12*	DT3	—	—
13*	N position signal	—	—
14	Closed throttle position switch (in throttle position switch)	When releasing accelerator pedal after warming up engine.	Battery voltage
		When depressing accelerator pedal after warming up engine.	1V or less
15	Ground	—	—
16	Inhibitor "1" position switch	When setting selector lever to "1" position.	Battery voltage
		When setting selector lever to other positions.	1V or less
17	Inhibitor "2" position switch	When setting selector lever to "2" position.	Battery voltage
		When setting selector lever to other positions.	1V or less
18	Inhibitor "D" position switch	When setting selector lever to "D" position.	Battery voltage
		When setting selector lever to other positions.	1V or less

\*: These terminals are connected to the ECM (ECCS control module).

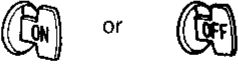
# TROUBLE DIAGNOSES

## Electrical Components Inspection (Cont'd)







Terminal No.	Item	Condition		Judgement standard
19	Inhibitor "N" or "P" position switch		When setting selector lever to "N" or "P" position.	Battery voltage
			When setting selector lever to other positions.	1V or less
20	Inhibitor "R" position switch		When setting selector lever to "R" position.	Battery voltage
			When setting selector lever to other positions.	1V or less
21	Wide open throttle position switch (in throttle position switch)		When depressing accelerator pedal more than half-way after warming up engine.	Battery voltage
			When releasing accelerator pedal after warming up engine.	1V or less
22	—	—	—	—
23	Power source (Back-up)		When turning ignition switch to "OFF".	Battery voltage
			When turning ignition switch to "ON".	Battery voltage
24	Engine speed signal		When engine runs at idle speed.	0.9V
			When engine runs at 4,000 rpm.	Approximately 3.7V
25	Revolution sensor (Measure in AC position)		When vehicle cruises at 30 km/h (19 MPH).	1V or more Voltage rises gradually in response to vehicle speed.
			When vehicle parks.	0V
26	—	—	—	—
27	Vehicle speed sensor	—	When moving vehicle at 2 to 3 km/h (1 to 2 MPH) for 1 m (3 ft) or more.	Vary from 0 to 5V
28*	—	—	—	—
29*	—	—	—	—
30*	—	—	—	—
31	Throttle position sensor (Power source)		—	4.5 - 5.5V
32	—	—	—	—

\*: These terminals are connected to the Data link connector for CONSULT.



# TROUBLE DIAGNOSES

## Electrical Components Inspection (Cont'd)

Terminal No.	Item	Condition	Judgement standard		
33	A/T fluid temperature sensor		When ATF temperature is 20°C (68°F).	Approximately 1.5V	GI
			When ATF temperature is 80°C (176°F).	Approximately 0.5V	
34	Throttle position sensor		When depressing accelerator pedal slowly after warming up engine. (Voltage rises gradually in response to throttle position.)	Fully-closed throttle: Approximately 0.5V Fully-open throttle: Approximately 4V	MA EM
35	Throttle position sensor (Ground)		—	—	LC
36	—	—	—	—	—
37	ASCD cruise signal		When ASCD cruise is being performed. ("CRUISE" light comes on.)	Battery voltage	EC
			When ASCD cruise is not being performed. ("CRUISE" light does not come on.)	1V or less	FE
38	DT5*		—	—	CL
39	Overdrive OFF switch		When setting overdrive switch in "ON" position	Battery voltage	MT
		When setting overdrive switch in "OFF" position	1V or less		
40	ASCD OD cut signal		When "ACCEL" set switch on ASCD cruise is released.	5 - 8V	AT
			When "ACCEL" set switch on ASCD cruise is applied.	1V or less	FA
41	—	—	—	—	—
42	—	—	—	—	RA
43	Stop lamp switch		When depressing brake pedal	Battery voltage	BR
			When releasing brake pedal	1V or less	
44	—	—	—	—	—
45	OBD-II*		—	—	ST
46	—		—	—	RS
47	DT4*		—	—	—
48	Ground		—	—	—

\* These terminals are connected to the ECM (ECCS control module).

## TROUBLE DIAGNOSES

### Electrical Components Inspection (Cont'd) SOLENOID VALVES AND A/T FLUID TEMPERATURE SENSOR

- For removal and installation, refer to "ON-VEHICLE SERVICE", AT-124.

#### Solenoid valves

##### Resistance check

- Check resistance between two terminals.

Solenoid valve	Terminal No.	Resistance (Approx.)
Shift solenoid valve A	②	20 - 30Ω
Shift solenoid valve B	①	
Overrun clutch solenoid valve	③	
Line pressure solenoid valve	④	2.5 - 5Ω
Torque converter clutch solenoid valve	⑤	10 - 16Ω

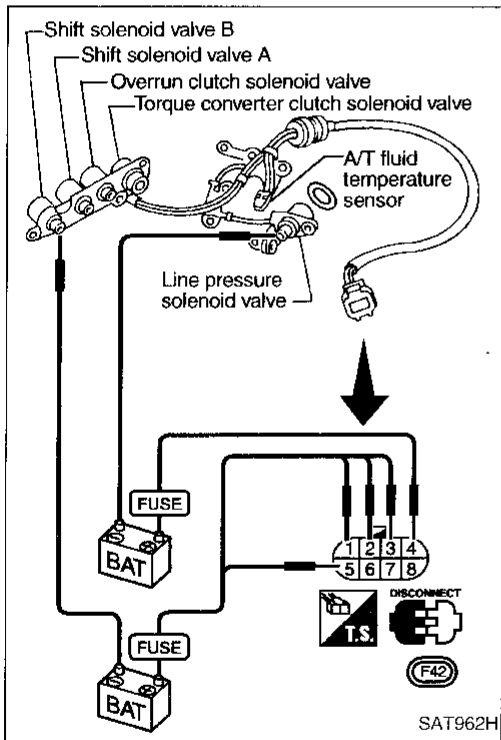
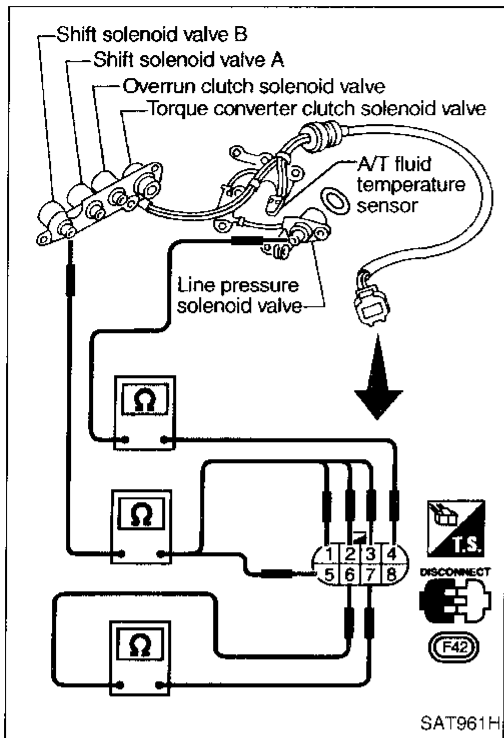

#### Operation check

- Check solenoid valve by listening for its operating sound while applying battery voltage to the terminal and ground (bracket).

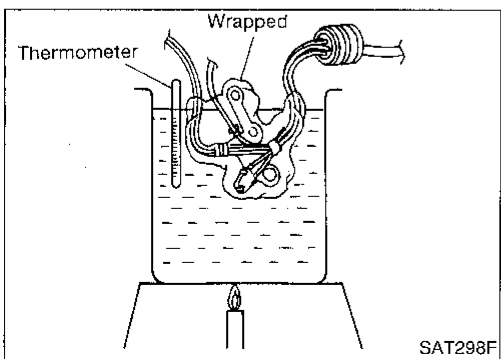

#### A/T fluid temperature sensor

Check resistance between terminals ⑥ and ⑦ while changing temperature as shown at left.

Temperature °C (°F)	Resistance (Approx.)
20 (68)	2.5 kΩ
80 (176)	0.3 kΩ

# TROUBLE DIAGNOSES

## Electrical Components Inspection (Cont'd)

### OVERDRIVE SWITCH

- Check continuity between two terminals.

OD switch position	Continuity
ON	No
OFF	Yes

GI

MA

EM

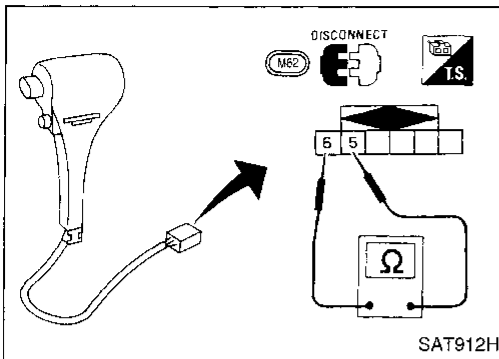

### INHIBITOR SWITCH

1. Check continuity between terminals ① and ② and between terminals ③ and ④, ⑤, ⑥, ⑦, ⑧, ⑨ while moving selector lever through each position.

Lever position	Terminal No.	
P	① — ②	③ — ④
R	③ — ⑤	
N	① — ②	③ — ⑥
D	③ — ⑦	
2	③ — ⑧	
1	③ — ⑨	

LC

EC

FE

CL

MT

AT

FA

RA

BR

ST

RS

BT

HA

EL

DX

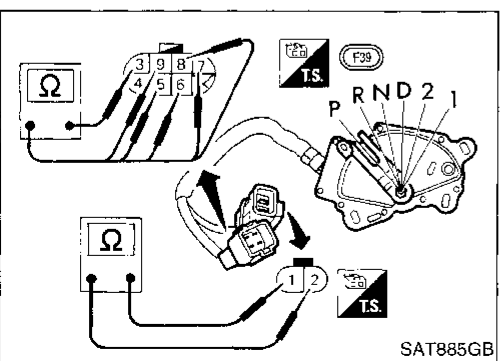
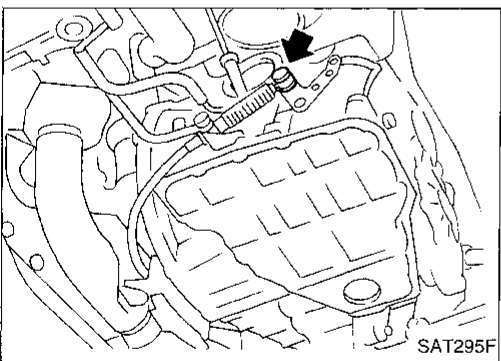
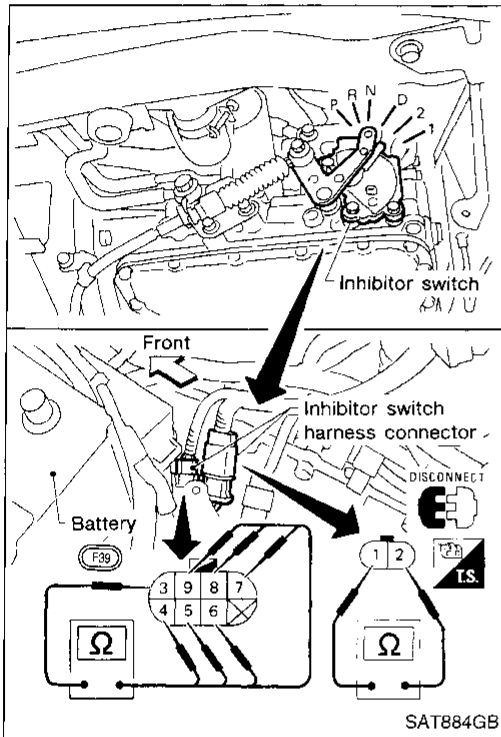

2. If NG, check again with control cable disconnected from manual shaft of A/T assembly. Refer to step 1.
3. If OK on step 2, adjust control cable. Refer to "ON-VEHICLE SERVICE", AT-77.

4. If NG on step 2, remove inhibitor switch from A/T and check continuity of inhibitor switch terminals. Refer to step 1.
5. If OK on step 4, adjust inhibitor switch. Refer to "ON-VEHICLE SERVICE", AT-73.
6. If NG on step 4, replace inhibitor switch.

## TROUBLE DIAGNOSES

### Electrical Components Inspection (Cont'd)

#### REVOLUTION SENSOR

- For removal and installation, refer to "ON-VEHICLE SERVICE", AT-125.
- Check resistance between terminals ①, ② and ③.

Terminal No.		Resistance
③	②	500 - 650Ω
②	①	No continuity
③	①	No continuity

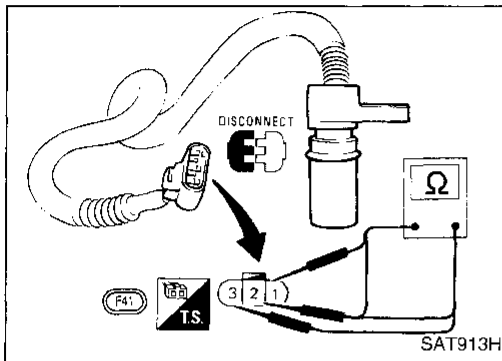

#### DROPPING RESISTOR

- Check resistance between two terminals.  
**Resistance: 11.2 - 12.8Ω**

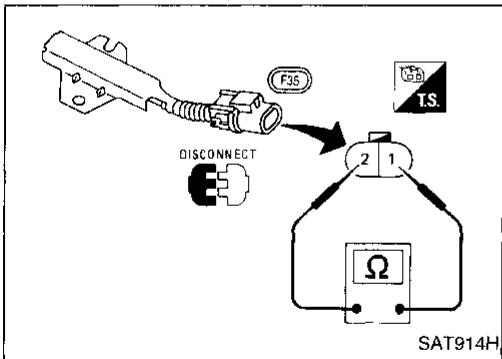

#### THROTTLE POSITION SWITCH

##### Closed throttle position switch (idle position)

- Check continuity between terminals ③ and ②.

Accelerator pedal condition	Continuity
Released	Yes
Depressed	No

- To adjust closed throttle position switch, perform Basic Inspection of TROUBLE DIAGNOSIS — General Description in EC section.

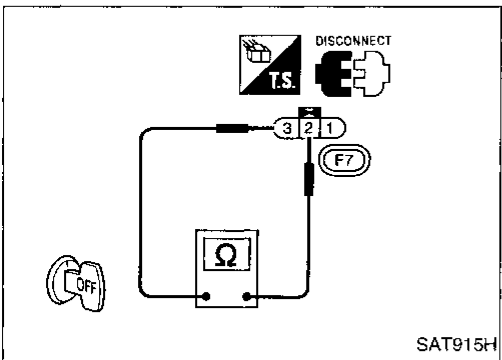

##### Wide open throttle position switch

- Check continuity between terminals ② and ①.

Accelerator pedal condition	Continuity
Released	No
Depressed	Yes

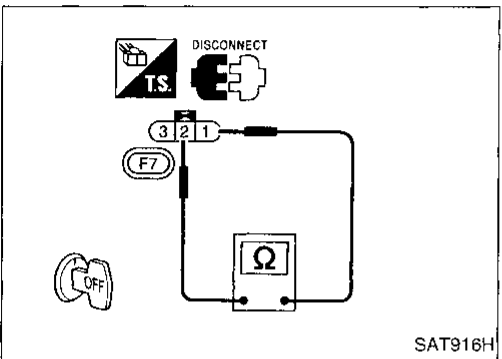

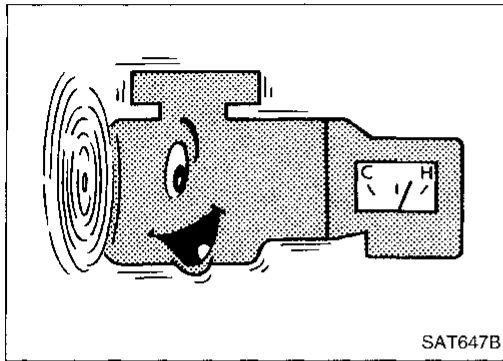

## Final Check

### STALL TESTING

#### Stall test procedure

1. Check A/T and engine fluid levels. If necessary, add.
2. Drive vehicle for approx. 10 minutes or until engine oil and ATF reach operating temperature.

**ATF operating temperature:  
50 - 80°C (122 - 176°F)**

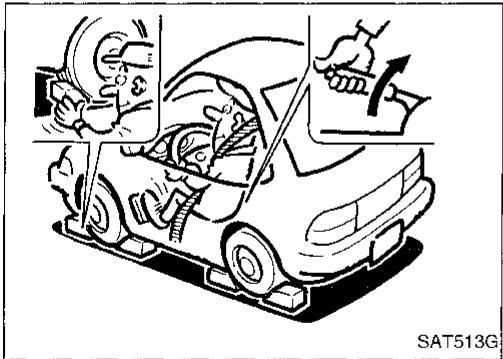

3. Set parking brake and block wheels.
4. Install a tachometer where it can be seen by driver during test.
  - **It is good practice to put a mark on point of specified engine rpm on indicator.**

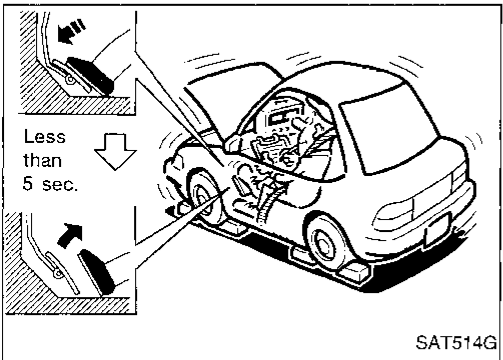

5. Start engine, apply foot brake, and place selector lever in "D" position.
6. Accelerate to wide-open throttle gradually while applying foot brake.
7. Quickly note the engine stall revolution and immediately release throttle.

- **During test, never hold throttle wide-open for more than 5 seconds.**

**Stall revolution:  
2,000 - 2,300 rpm**

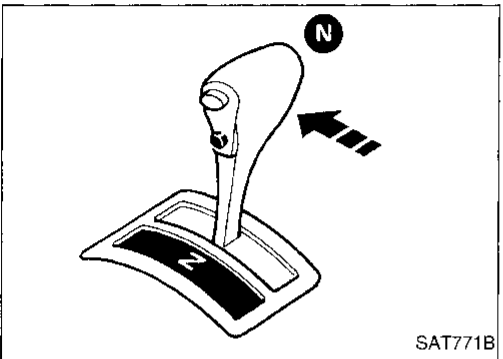

8. Move selector lever to "N" position.
9. Cool off ATF.
  - **Run engine at idle for at least one minute.**
10. Repeat steps 5 through 9 with selector lever in "2", "1" and "R" positions.

GI

MA

EM

LC

EC

FE

CL

MT

AT

FA

RA

BR

ST

RS

BT

HA

EL

IDX

## TROUBLE DIAGNOSES

### Final Check (Cont'd)

#### JUDGEMENT OF STALL TEST

The test result and possible damaged components relating to each result are shown in the illustration. In order to pinpoint the possible damaged components, follow the WORK FLOW shown in AT-15.

#### Note

##### Stall revolution is too high in "D", "2" or "1" position:

- Slippage occurs in 1st gear but not in 2nd and 3rd gears. .... Low one-way clutch slippage
- Slippage occurs in the following gears:  
1st through 3rd gears in "D" position and engine brake functions with overdrive switch set to "OFF".  
1st and 2nd gears in "2" position and engine brake functions with accelerator pedal released (fully closed throttle). .... Forward clutch or forward one-way clutch slippage

##### Stall revolution is too high in "R" position:

- Engine brake does not function in "1" position. .... Low & reverse brake slippage
- Engine brake functions in "1" position. .... Reverse clutch slippage

##### Stall revolution within specifications:

- Vehicle does not achieve speed of more than 80 km/h (50 MPH). .... One-way clutch seizure in torque converter housing

#### CAUTION:

##### Be careful since automatic fluid temperature increases abnormally.

- Slippage occurs in 3rd and 4th gears in "D" position. .... High clutch slippage
- Slippage occurs in 2nd and 4th gear in "D" position. .... Brake band slippage
- Engine brake does not function in 2nd and 3rd gears in "D" position, 2nd gear in "2" position, and 1st gear in "1" position with overdrive switch set to "OFF".

##### Stall revolution less than specifications:

- Poor acceleration during starts. .... One-way clutch seizure in torque converter

# TROUBLE DIAGNOSES

## Final Check (Cont'd)

### Judgement of stall test

Selector lever position	Judgement		
	H	O	L
D	H	O	L
2	H	O	L
1	H	O	L
R	O	H	L

O : Stall revolution is normal.  
H : Stall revolution is higher than specified.  
L : Stall revolution is lower than specified.

Damaged components

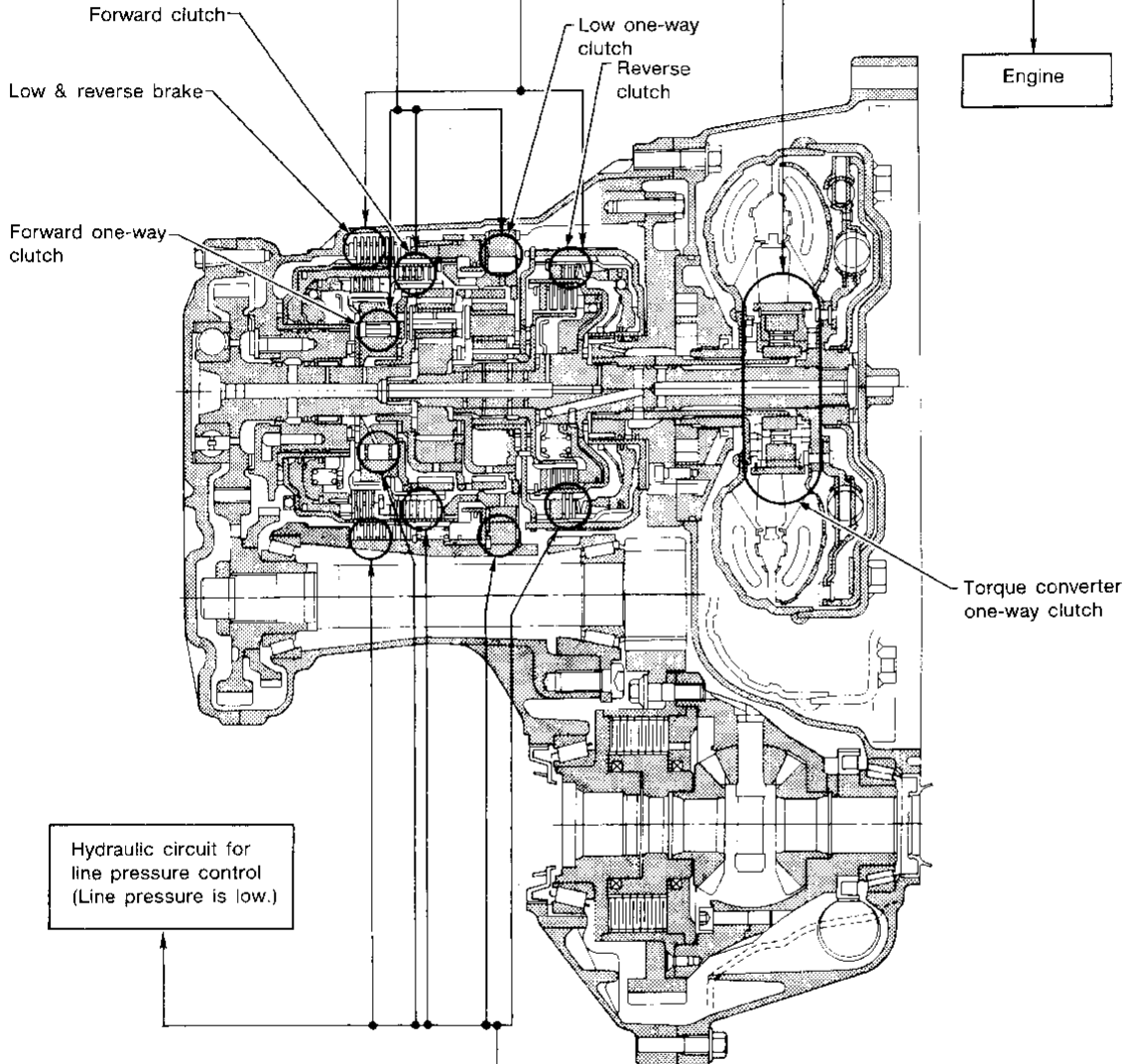

Hydraulic circuit for line pressure control (Line pressure is low.)

Clutches and brakes except high clutch, brake band and overrun clutch are OK. (Condition of high clutch, brake band and overrun clutch cannot be confirmed by stall test.)

D	H	O
2	H	O
1	H	O
R	H	O
Selector lever position	Judgement	

CI

MA

EM

LC

EC

FE

CL

MT

**AT**

FA

RA

BR

ST

RS

BT

HA

EL

IDX

## TROUBLE DIAGNOSES

### Final Check (Cont'd)

#### PRESSURE TESTING

- Location of pressure test ports.
- **Always replace pressure plugs as they are self-sealing bolts.**

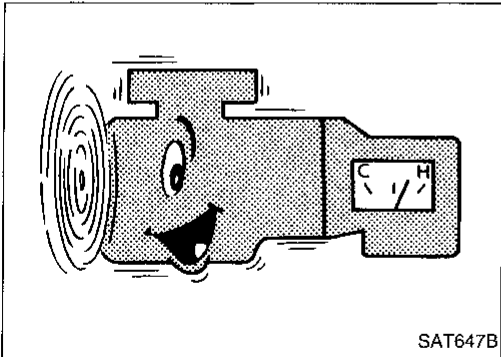
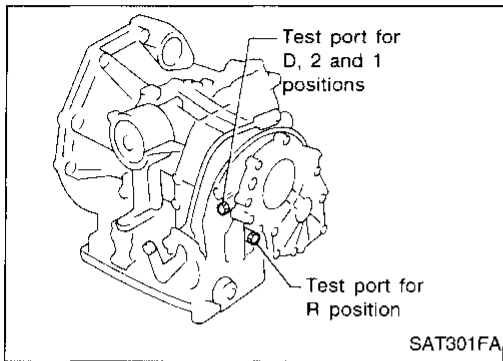

#### Line pressure test procedure

1. Check A/T and engine fluid levels. If necessary, add fluid.
2. Drive vehicle for approx. 10 minutes or until engine oil and ATF reach operating temperature.

**ATF operating temperature:**  
50 - 80°C (122 - 176°F)

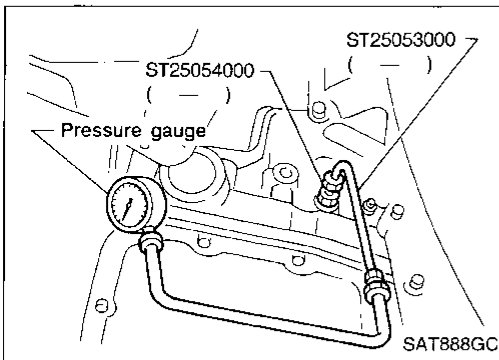

3. Install pressure gauge to corresponding line pressure port.

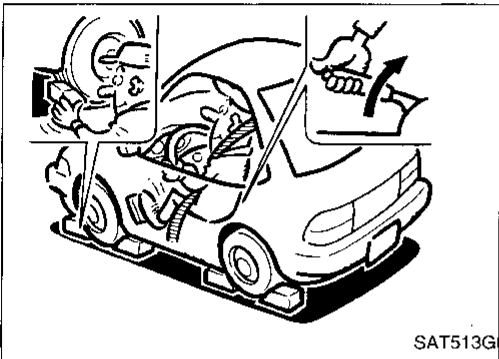

4. Set parking brake and block wheels.
- **Continue to depress brake pedal fully while line pressure test is being performed at stall speed.**



# TROUBLE DIAGNOSES

## Final Check (Cont'd)

5. Start engine and measure line pressure at idle and stall speed.
  - **When measuring line pressure at stall speed, follow the stall test procedure.**

**Line pressure: Refer to SDS, AT-224.**

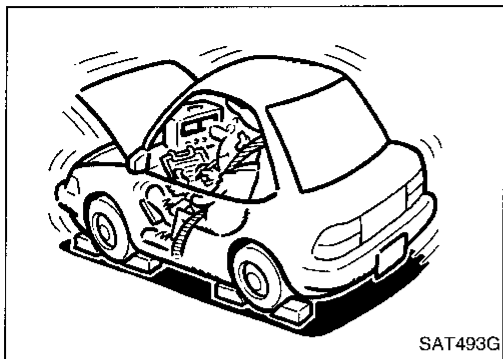

### JUDGEMENT OF LINE PRESSURE TEST

Judgement		Suspected parts
At idle	Line pressure is low in all positions.	<ul style="list-style-type: none"> <li>• Oil pump wear</li> <li>• Control piston damage</li> <li>• Pressure regulator valve or plug sticking</li> <li>• Spring for pressure regulator valve damaged</li> <li>• Fluid pressure leakage between oil strainer and pressure regulator valve</li> <li>• Clogged strainer</li> </ul>
	Line pressure is low in particular position.	<ul style="list-style-type: none"> <li>• Fluid pressure leakage between manual valve and particular clutch</li> <li>• For example, line pressure is:                             <ul style="list-style-type: none"> <li>— Low in "R" and "1" positions, but</li> <li>— Normal in "D" and "2" positions.</li> </ul> </li> </ul> Therefore, fluid leakage exists at or around low and reverse brake circuit. Refer to "OPERATION OF CLUTCH AND BRAKE", AT-12.
	Line pressure is high.	<ul style="list-style-type: none"> <li>• Mal-adjustment of throttle position sensor</li> <li>• A/T fluid temperature sensor damaged</li> <li>• Line pressure solenoid valve sticking</li> <li>• Short circuit of line pressure solenoid valve circuit</li> <li>• Pressure modifier valve sticking</li> <li>• Pressure regulator valve or plug sticking</li> <li>• Open in dropping resistor circuit</li> </ul>
At stall speed	Line pressure is low.	<ul style="list-style-type: none"> <li>• Mal-adjustment of throttle position sensor</li> <li>• Line pressure solenoid valve sticking</li> <li>• Short circuit of line pressure solenoid valve circuit</li> <li>• Pressure regulator valve or plug sticking</li> <li>• Pressure modifier valve sticking</li> <li>• Pilot valve sticking</li> </ul>

CI  
 MA  
 EM  
 LC  
 EC  
 FE  
 CL  
 MT  
**AT**  
 FA  
 RA  
 BR  
 ST  
 RS  
 BT  
 HA  
 EL  
 DX

# TROUBLE DIAGNOSES

## Symptom Chart

Reference page (AT- )		ON vehicle										OFF vehicle																			
		25, 77	73	52, 54, 69	71	124, 58	60, 71	64, 62	66, 124	124	133, 149	167, 170	174, 184	174	180, 191	—															
Reference page (AT- )		Fluid level	Control cable	Inhibitor switch	Throttle position sensor (Adjustment)	Revolution sensor and vehicle speed sensor	Engine speed signal	Engine idling rpm	Line pressure	Control valve assembly	Shift solenoid valve A	Shift solenoid valve B	Line pressure solenoid valve	Torque converter clutch solenoid valve	Overrun clutch solenoid valve	AT fluid temperature sensor	Accumulator N-D	Accumulator servo release	Ignition switch and starter	Torque converter	Oil pump	Reverse clutch	High clutch	Forward clutch	Forward one-way clutch	Overrun clutch	Low one-way clutch	Low & reverse brake	Brake band	Parking components	
88	Engine does not start in "N", "P" positions.	2	3															1													
88	Engine starts in positions other than "N" and "P".	1	2																												
—	Transaxle noise in "P" and "N" positions.	1	3	4	5	2														7	6										
88	Vehicle moves when changing into "P" position or parking gear does not disengage when shifted out of "P" position.	1																												2	
89	Vehicle runs in "N" position.	1																				3		2	4						
91	Vehicle will not run in "R" position (but runs in "D", "2" and "1" positions). Clutch slips. Very poor acceleration.	1				2	4			3												5	6	7	8	9					
—	Vehicle braked when shifting into "R" position.	1	2			3	5			4												6	8	9				7			
—	Sharp shock in shifting from "N" to "D" position.		2		5	1	3	7		6			4	8									9								
—	Vehicle will not run in "D" and "2" positions (but runs in "1" and "R" positions).	1																								2					
92	Vehicle will not run in "D", "1", "2" positions (but runs in "R" position). Clutch slips. Very poor acceleration.	1				2	4			3												6	7	8	9		10				
—	Clutches or brakes slip somewhat in starting.	1	2	3		4	6			5											10	11	9	8				10			
—	Excessive creep.					1																									
91, 92	No creep at all.	1				2	3													6	5			4							
—	Failure to change gear from "D <sub>1</sub> " to "D <sub>2</sub> ".	2	1	5			4	3																						6	
—	Failure to change gear from "D <sub>2</sub> " to "D <sub>3</sub> ".	2	1	5			4	3														6								7	
—	Failure to change gear from "D <sub>3</sub> " to "D <sub>4</sub> ".	2	1	4				3					5																	6	
94, 95, 96	Too high a gear change point from "D <sub>1</sub> " to "D <sub>2</sub> ", from "D <sub>2</sub> " to "D <sub>3</sub> ", from "D <sub>3</sub> " to "D <sub>4</sub> ".			1	2			3	4																						
—	Gear change directly from "D <sub>1</sub> " to "D <sub>3</sub> " occurs.	1																2												3	
—	Engine stops when shifting lever into "R", "D", "2" and "1".					1	3					2								4											
—	Too sharp a shock in change from "D <sub>1</sub> " to "D <sub>2</sub> ".			1		2	4						5	3																6	
—	Too sharp a shock in change from "D <sub>2</sub> " to "D <sub>3</sub> ".			1		2	3																4							5	

# TROUBLE DIAGNOSES

## Symptom Chart (Cont'd)

Reference page (AT- )	ON vehicle										OFF vehicle																			
	25, 77	73	52, 54, 69,	71	124, 58	60, 71	64, 62	66, 124	124	133, 149	167, 170	174, 184	174	180, 191	—															
Reference page (AT- )	Fluid level	Control cable	Inhibitor switch	Throttle position sensor (Adjustment)	Revolution sensor and vehicle speed sensor	Engine speed signal	Engine idling rpm	Line pressure	Control valve assembly	Shift solenoid valve A	Shift solenoid valve B	Line pressure solenoid valve	Torque converter clutch solenoid valve	Overrun clutch solenoid valve	A/T fluid temperature sensor	Accumulator N-D	Accumulator servo release	Ignition switch and starter	Torque converter	Oil pump	Reverse clutch	High clutch	Forward clutch	Forward one-way clutch	Overrun clutch	Low one-way clutch	Low & reverse brake	Brake band	Parking components	
—	Too sharp a shock in change from "D <sub>3</sub> " to "D <sub>4</sub> ".		1			2	3																		⑤			④		
—	Almost no shock or clutches slipping in change from "D <sub>1</sub> " to "D <sub>2</sub> ".	1		2			3	5								4													⑥	
—	Almost no shock or slipping in change from "D <sub>2</sub> " to "D <sub>3</sub> ".	1		2			3	4																					⑥	
—	Almost no shock or slipping in change from "D <sub>3</sub> " to "D <sub>4</sub> ".	1		2			3	4																					⑥	
—	Vehicle braked by gear change from "D <sub>1</sub> " to "D <sub>2</sub> ".	1																									⑤	③		
—	Vehicle braked by gear change from "D <sub>2</sub> " to "D <sub>3</sub> ".	1																											②	
—	Vehicle braked by gear change from "D <sub>3</sub> " to "D <sub>4</sub> ".	1																				④		③	②					
—	Maximum speed not attained. Acceleration poor.	1	2				5	3	4										⑨	⑩	⑥	⑦					⑨	⑧		
—	Failure to change gear from "D <sub>4</sub> " to "D <sub>3</sub> ".	1		2			6	4	5	3															⑧		⑦			
—	Failure to change gear from "D <sub>3</sub> " to "D <sub>2</sub> " or from "D <sub>4</sub> " to "D <sub>2</sub> ".	1		2			5	3	4																			⑦		
—	Failure to change gear from "D <sub>2</sub> " to "D <sub>1</sub> " or from "D <sub>3</sub> " to "D <sub>1</sub> ".	1		2			5	3	4																	⑥		⑧		
—	Gear change shock felt during deceleration by releasing accelerator pedal.			1			2	4				3																		
—	Too high a change point from "D <sub>4</sub> " to "D <sub>3</sub> ", from "D <sub>3</sub> " to "D <sub>2</sub> ", from "D <sub>2</sub> " to "D <sub>1</sub> ".			1	2																									
—	Kickdown does not operate when depressing pedal in "D <sub>4</sub> " within kickdown vehicle speed.			1	2			3	4																					
—	Kickdown operates or engine overruns when depressing pedal in "D <sub>4</sub> " beyond kickdown vehicle speed limit.			2	1			3	4																					
—	Races extremely fast or slips in changing from "D <sub>4</sub> " to "D <sub>3</sub> " when depressing pedal.	1		2			3	5		4													⑥	⑦						
—	Races extremely fast or slips in changing from "D <sub>4</sub> " to "D <sub>2</sub> " when depressing pedal.	1		2			3	6	5	4														⑧				⑦		
—	Races extremely fast or slips in changing from "D <sub>3</sub> " to "D <sub>2</sub> " when depressing pedal.	1		2			3	5		4			6										⑨	⑧				⑦		
—	Races extremely fast or slips in changing from "D <sub>4</sub> " or "D <sub>3</sub> " to "D <sub>1</sub> " when depressing pedal.	1		2			3	5		4														⑥	⑦		⑧			
—	Vehicle will not run in any position.	1	2				3			4									⑨	⑤		⑥						⑧	⑦	⑩
—	Transaxle noise in "D", "2", "1" and "R" positions.	1																	②											

GI  
 MA  
 EM  
 LG  
 FC  
 FE  
 CL  
 MT  
**AT**  
 FA  
 RA  
 BR  
 ST  
 RS  
 BT  
 HA  
 EL  
 DX

# TROUBLE DIAGNOSES

## Symptom Chart (Cont'd)

Reference page (AT- )		ON vehicle										OFF vehicle																		
		25, 77	73	52, 54, 69,	71	124, 58	60, 71	64, 62	66, 124	124	133, 149	167, 170	174, 184	174	180, 191	—														
Reference page (AT- )	Numbers are arranged in order of probability. Perform inspections starting with number one and work up. Circled numbers indicate that the transaxle must be removed from the vehicle.	Fluid level	Control cable	Inhibitor switch	Throttle position sensor (Adjustment)	Revolution sensor and vehicle speed sensor	Engine speed signal	Engine idling rpm	Line pressure	Control valve assembly	Shift solenoid valve A	Shift solenoid valve B	Line pressure solenoid valve	Torque converter clutch solenoid valve	Overrun clutch solenoid valve	A/T fluid temperature sensor	Accumulator N-D	Accumulator servo release	Ignition switch and starter	Torque converter	Oil pump	Reverse clutch	High clutch	Forward clutch	Forward one-way clutch	Overrun clutch	Low one-way clutch	Low & reverse brake	Brake band	Parking components
101	Failure to change from "D <sub>3</sub> " to "2 <sub>2</sub> " when changing lever into "2" position.	7	1	2					6	5	4		3												⑥			⑥		
—	Gear change from "2 <sub>2</sub> " to "2 <sub>3</sub> " in "2" position.		1																											
101	Engine brake does not operate in "1" position.	2	1	3	4				6	5			7												⑧		⑨			
—	Gear change from "1 <sub>1</sub> " to "1 <sub>2</sub> " in "1" position.	2	1																											
—	Does not change from "1 <sub>2</sub> " to "1 <sub>1</sub> " in "1" position.		1		2				4	3			5												⑥		⑦			
—	Large shock changing from "1 <sub>2</sub> " to "1 <sub>1</sub> " in "1" position.								1																		②			
—	Transaxle overheats.	1		3			2	4	6		5									⑭	⑦	⑧	⑨	⑩	⑪	⑫	⑬	⑭		
—	ATF shoots out during operation. White smoke emitted from exhaust pipe during operation.	1																				②	③	⑤	⑥		⑦	④		
—	Offensive smell at fluid charging pipe.	1																			②	③	④	⑤	⑦	⑧	⑨	⑥		
—	Torque converter is not locked up.		3	1	2	4		6	8			7		5						⑨										
—	Torque converter clutch piston slip.	1		2				3	6		5	4								⑦										
97	Lock-up point is extremely high or low.			1	2				4			3																		
—	A/T does not shift to "D <sub>4</sub> " when driving with overdrive switch "ON".		2	1	3			8	6	4			5	7											⑩			⑨		
—	Engine is stopped at "R", "D", "2" and "1" positions.	1							5	4	3	2																		

## Description

- The mechanical key interlock mechanism also operates as a shift lock:  
 With the key switch turned to "ON", the selector lever cannot be shifted from "P" (parking) to any other position unless the brake pedal is depressed.  
 With the key removed, the selector lever cannot be shifted from "P" to any other position.  
 The key cannot be removed unless the selector lever is placed in "P".
- The shift lock and key interlock mechanisms are controlled by the ON-OFF operation of the shift lock solenoid and by the operation of the rotator and slider located inside the key cylinder, respectively.

## Shift Lock System Electrical Parts Location

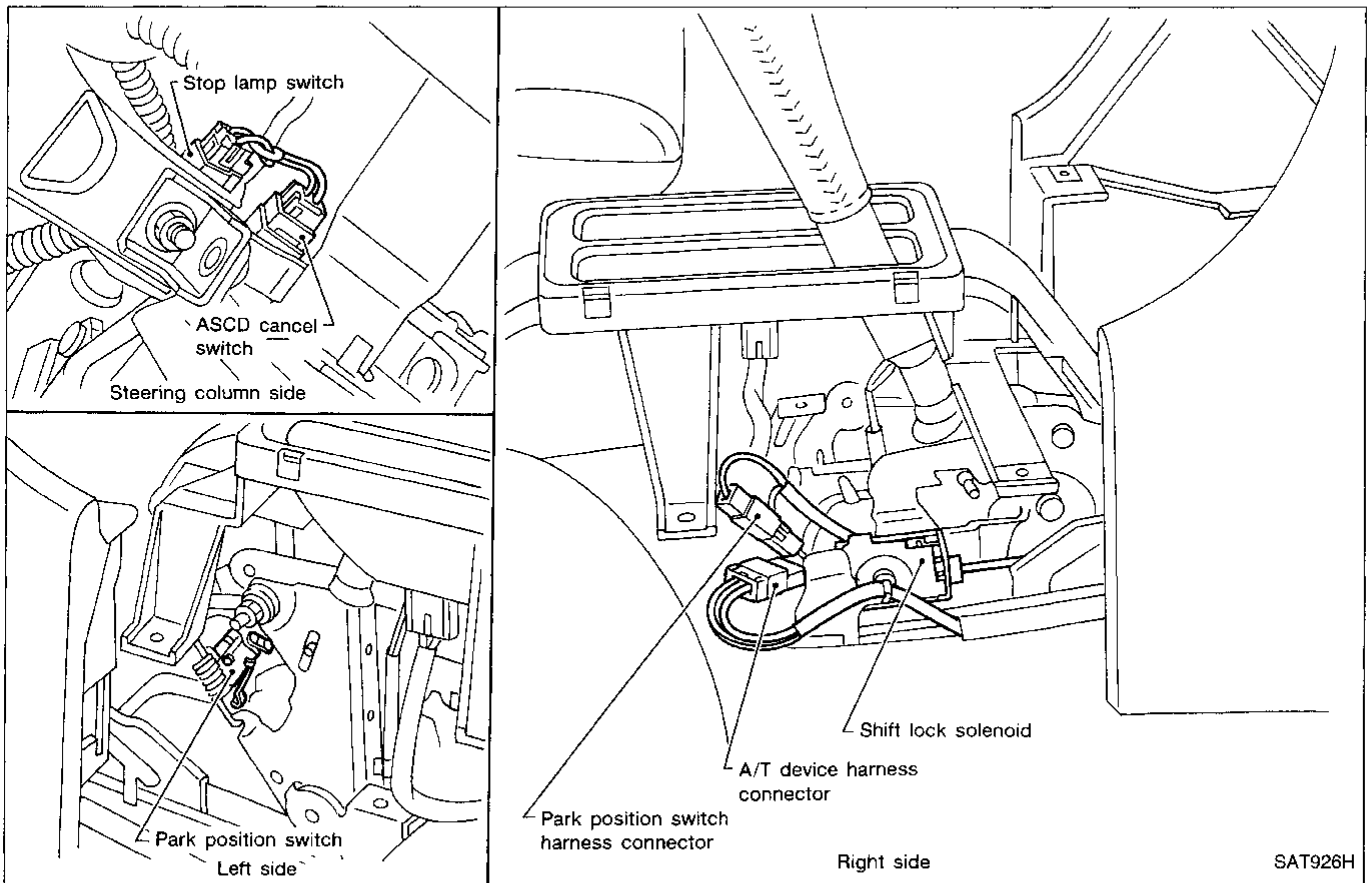

GI  
 MA  
 EM  
 LC  
 EC  
 FE  
 CL  
 MT  
**AT**  
 FA  
 RA  
 BR  
 ST  
 RS  
 BT  
 HA  
 EL  
 IDX

Wiring Diagram — SHIFT —

AT-SHIFT-01

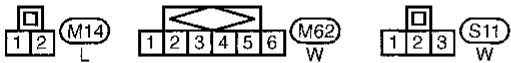
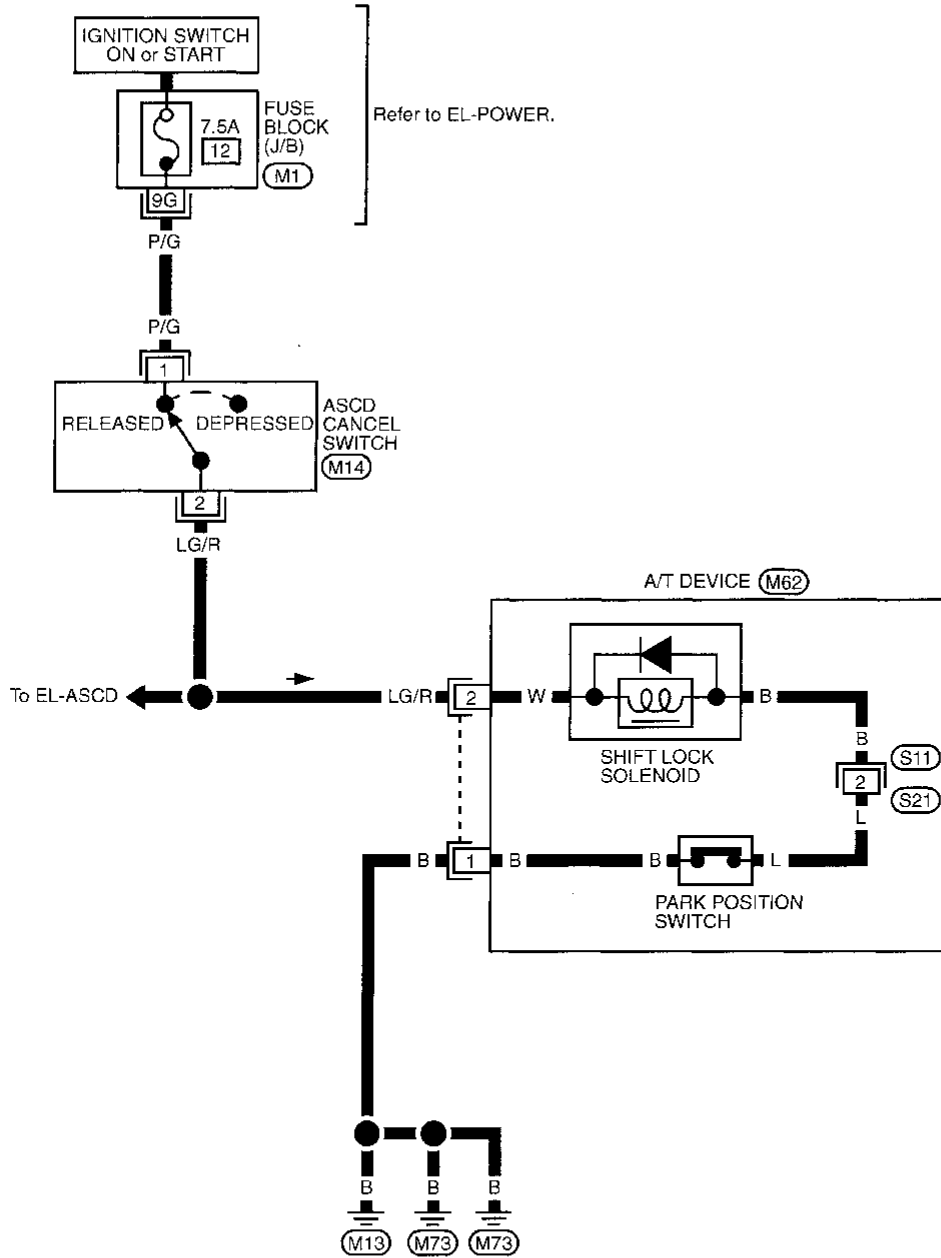

Refer to last page (Foldout page).  
(M1)

## Diagnostic Procedure

### SYMPTOM 1:

- Selector lever cannot be moved from "P" position with key in "ON" position and brake pedal applied.
- Selector lever can be moved from "P" position with key in "ON" position and brake pedal released.
- Selector lever can be moved from "P" position when key is removed from key cylinder.

### SYMPTOM 2:

Ignition key cannot be removed when selector lever is set to "P" position. It can be removed when selector lever is set to any position except "P".

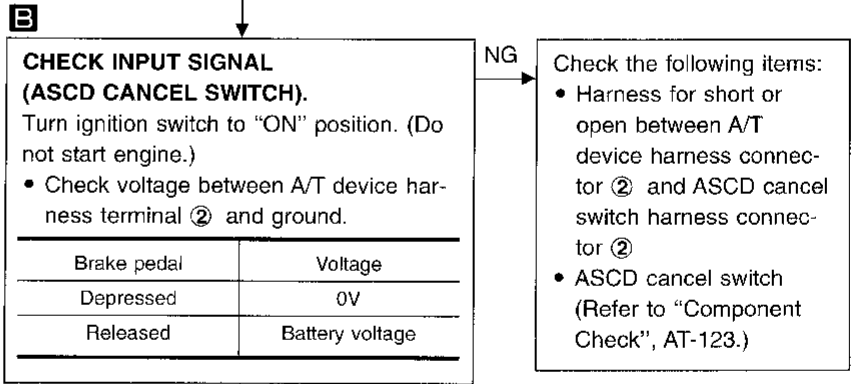
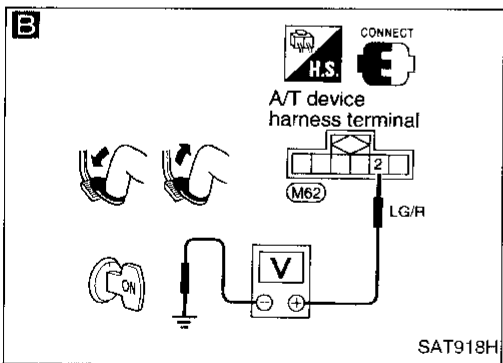
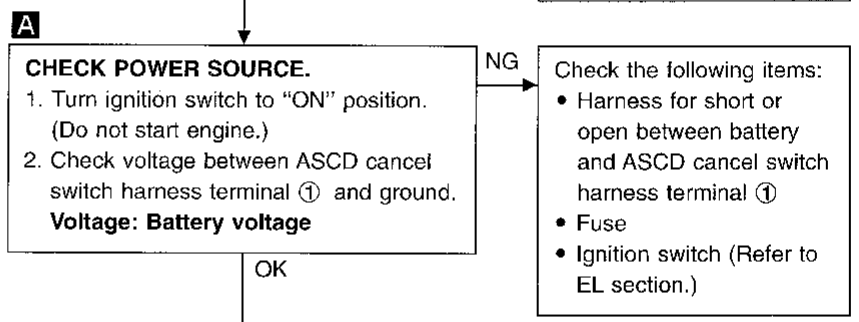
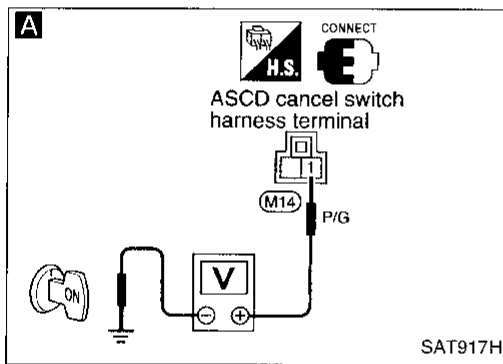
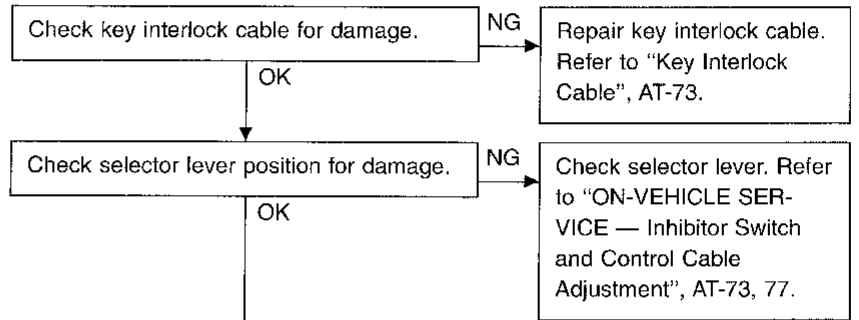

Brake pedal	Voltage
Depressed	0V
Released	Battery voltage

# TROUBLE DIAGNOSES — A/T Shift Lock System

## Diagnostic Procedure (Cont'd)

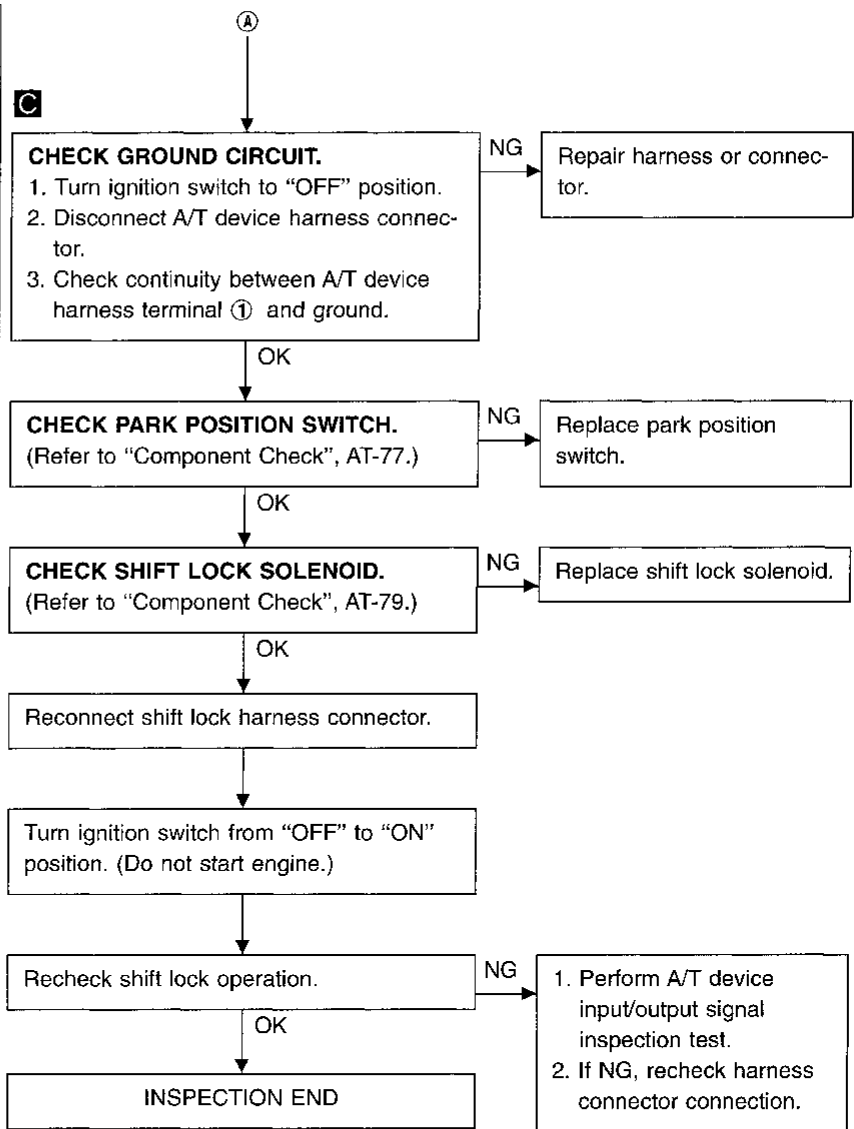
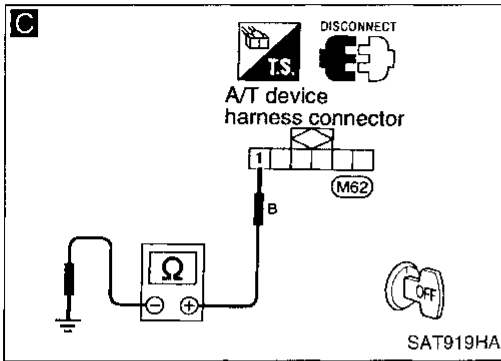



**Key Interlock Cable**

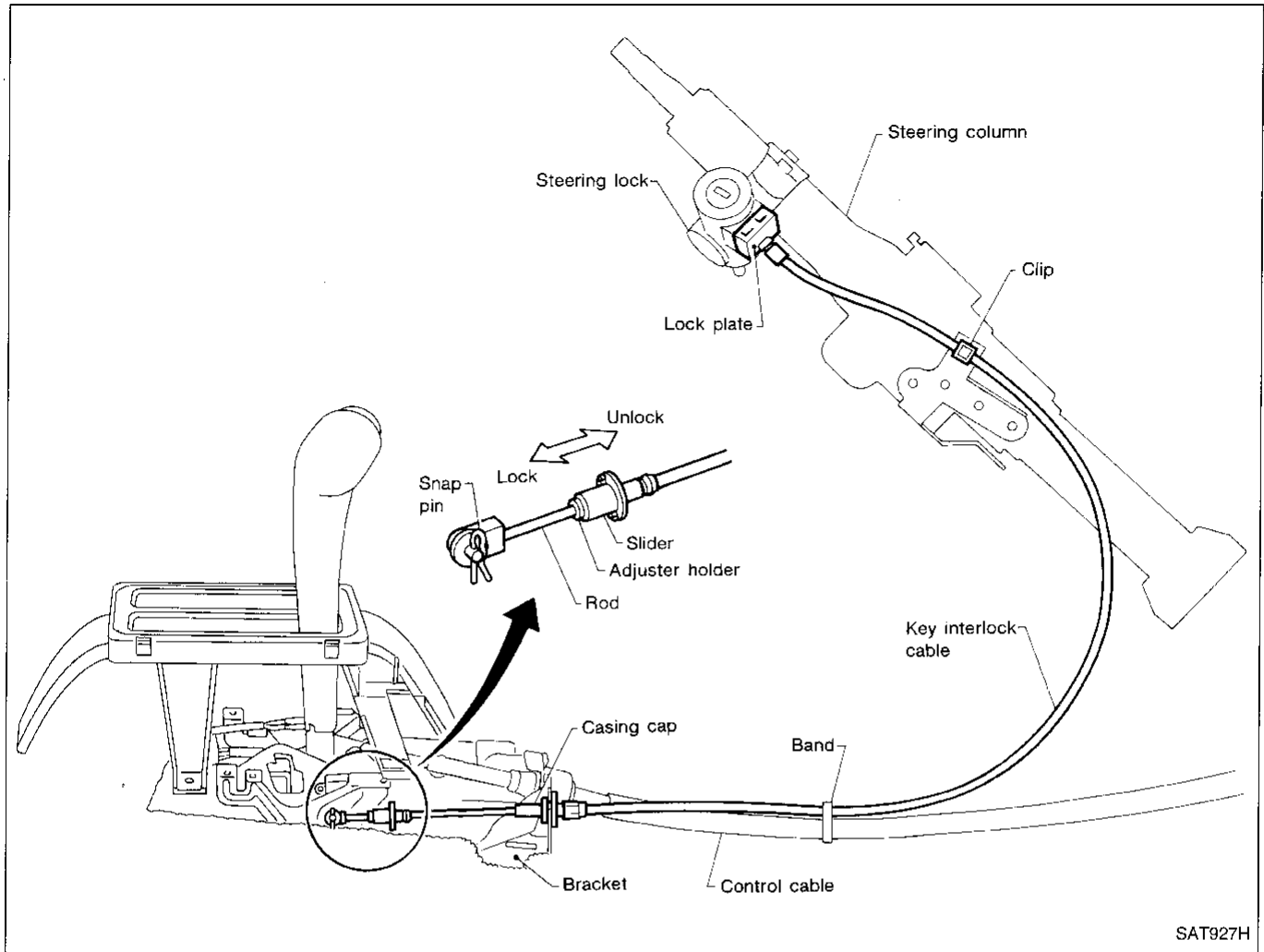

**CAUTION:**

- Install key interlock cable in such a way that it will not be damaged by sharp bends, twists or interference with adjacent parts.
- After installing key interlock cable to control device, make sure that casing cap and bracket are firmly secured in their positions. If casing cap can be removed with an external load of less than 39.2 N (4.0 kg, 8.8 lb), replace key interlock cable with new one.

**REMOVAL**

Unlock slider from adjuster holder and remove rod from cable.

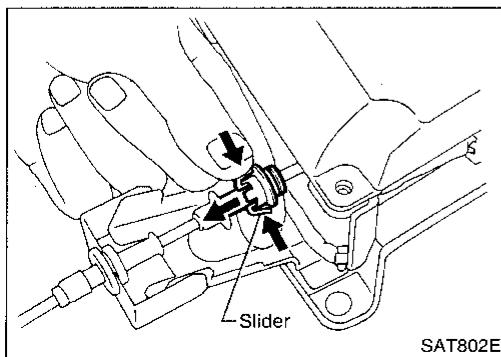

CI  
MA  
EM  
LC  
EC  
FE  
CL  
MT  
AT  
FA  
RA  
BR  
ST  
RS  
BT  
HA  
EL  
IDX

## TROUBLE DIAGNOSES — A/T Shift Lock System

### Key Interlock Cable (Cont'd)

#### INSTALLATION

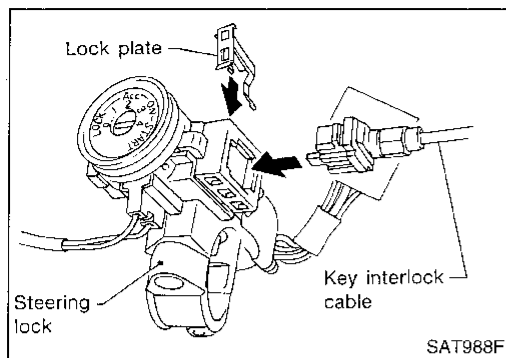

1. Set key interlock cable to steering lock assembly and install lock plate.
2. Clamp cable to steering column and fix to control cable with band.
3. Set control lever to P position.

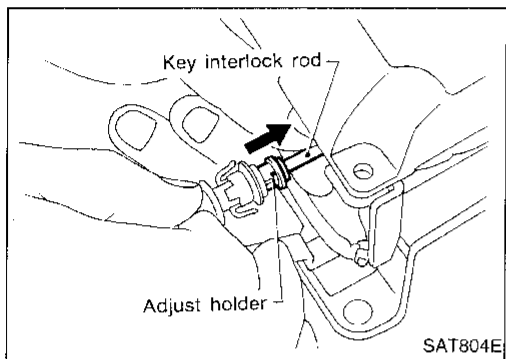

4. Insert interlock rod into adjuster holder.

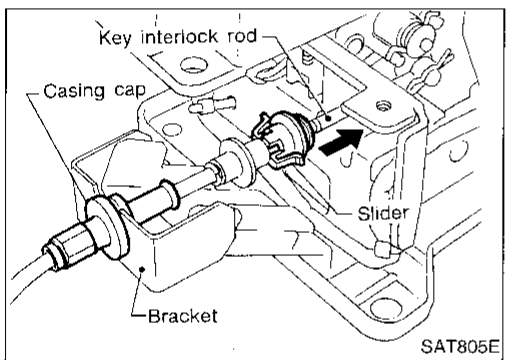

5. Install casing cap to bracket.
6. Move slider in order to fix adjuster holder to interlock rod.

### Component Check

#### SHIFT LOCK SOLENOID

- Check operation by applying battery voltage to A/T device and shift lock solenoid harness terminal.

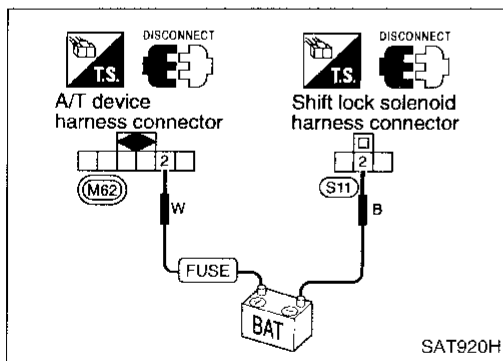

#### PARK POSITION SWITCH

- Check continuity between A/T device harness terminal ① and park position switch harness terminal ②.

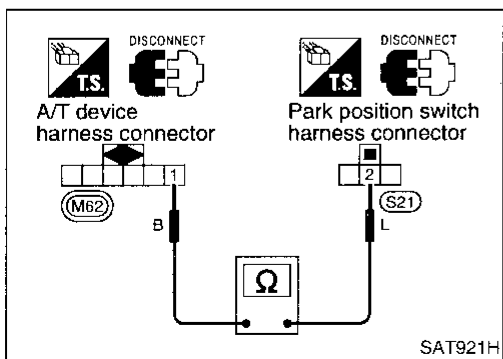

Condition	Continuity
When selector lever is set in "P" position and selector lever button is released	Yes
Except above	No

# TROUBLE DIAGNOSES — A/T Shift Lock System

## Component Check (Cont'd)

### ASCD CANCEL SWITCH

- Check continuity between terminals ① and ② .

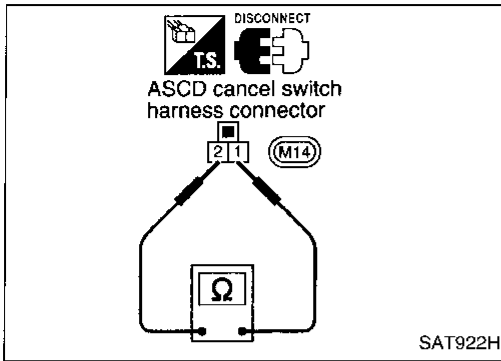

Condition	Continuity
When brake pedal is depressed	No
When brake pedal is released	Yes

**Check ASCD cancel switch after adjusting brake pedal — refer to BR section.**

GI

MA

EM

LC

EC

FE

CL

MT

**AT**

FA

RA

BR

ST

RS

BT

HA

EL

IDX

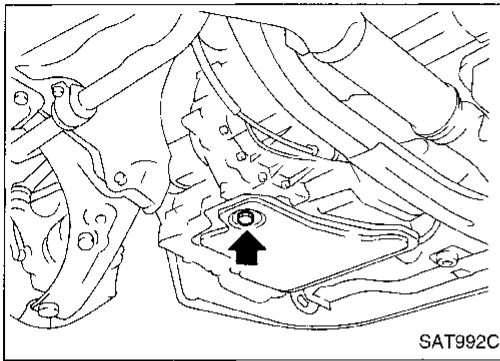

## Control Valve Assembly and Accumulator REMOVAL

1. Drain ATF from transaxle.
2. Remove oil pan and gasket.

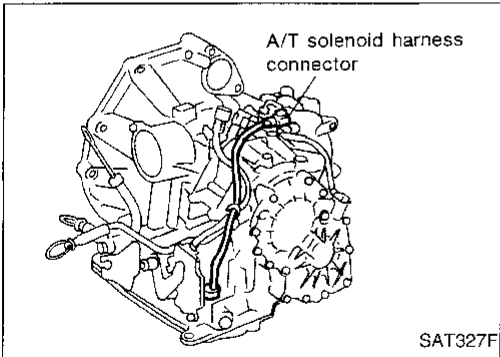

3. Disconnect A/T solenoid harness connector.

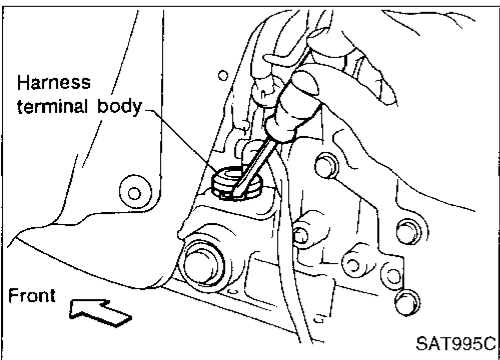

4. Remove stopper ring from terminal cord assembly harness terminal body.
5. Remove terminal cord assembly harness from transmission case by pushing on terminal body.

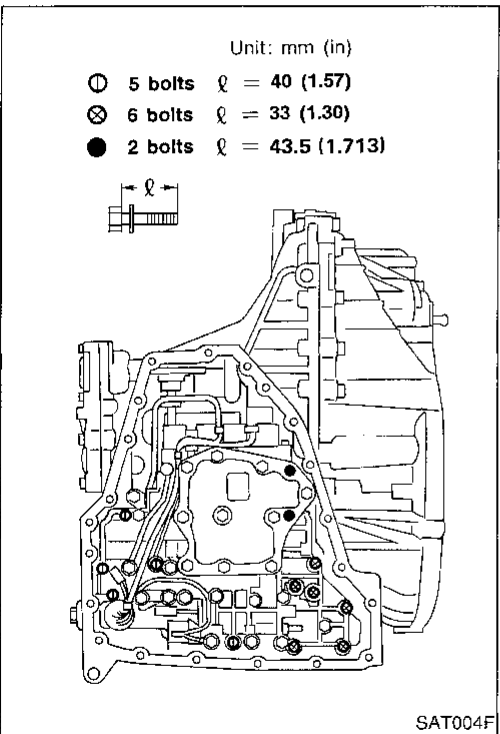

6. Remove control valve assembly by removing fixing bolts ①, ⊗ and ●.

Bolt length, number and location are shown in the illustration.

- **Be careful not to drop manual valve and servo release accumulator return spring.**

7. Disassemble and inspect control valve assembly if necessary. Refer to AT-153.

## ON-VEHICLE SERVICE

### Control Valve Assembly and Accumulator (Cont'd)

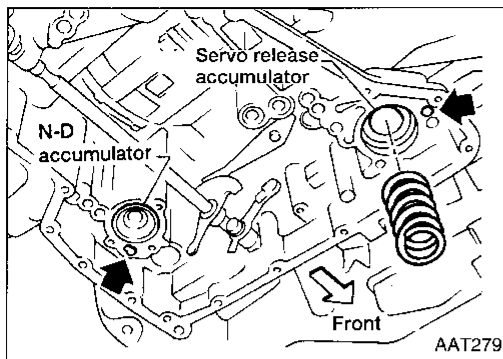

8. Remove servo release and N-D accumulators by applying compressed air if necessary.
  - Hold each piston with a rag.

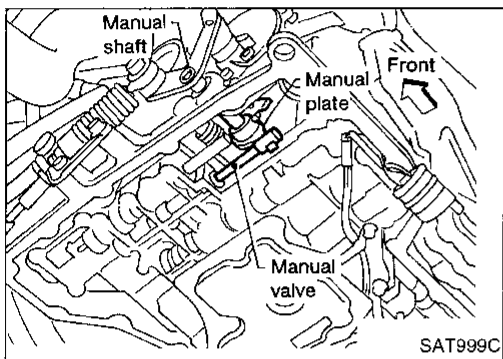

### INSTALLATION

- Set manual shaft in Neutral, then align manual plate with groove in manual valve.
- After installing control valve assembly, make sure that selector lever can be moved to all positions.

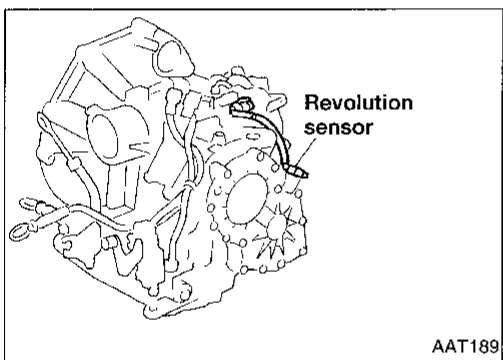

### Revolution Sensor Replacement

1. Remove under cover.
2. Remove revolution sensor from A/T.
3. Reinstall any part removed.

**Always use new sealing parts.**

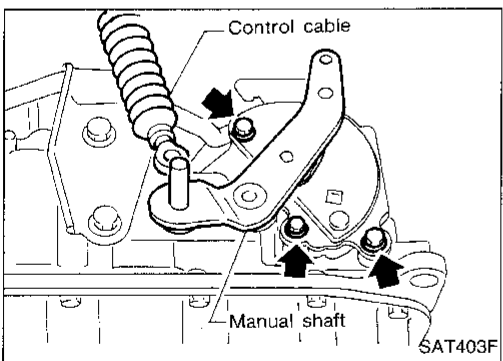

### Inhibitor Switch Adjustment

1. Remove control cable from manual shaft.
2. Set manual shaft in "N" position.
3. Loosen inhibitor switch fixing bolts.

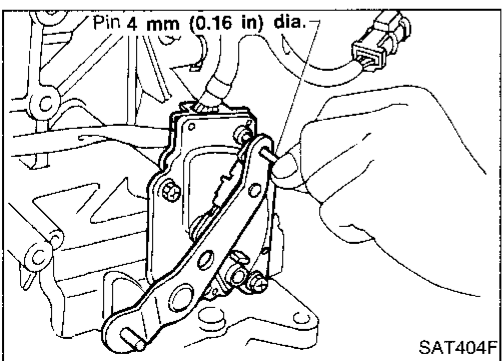

4. Insert pin into adjustment holes in both inhibitor switch and manual shaft as near vertical as possible.
5. Reinstall any part removed.
6. Check continuity of inhibitor switch. Refer to AT-107.

GI

MA

EM

LC

EC

FE

CL

MT

AT

FA

RA

BR

ST

RS

BT

HA

EL

IDX

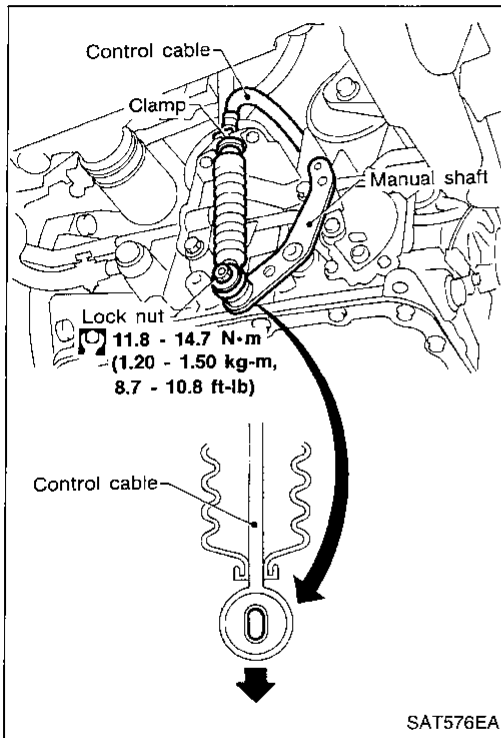

## Control Cable Adjustment

Move selector lever from the "P" position to the "1" position. You should be able to feel the detents in each position. If the detents cannot be felt or the pointer indicating the position is improperly aligned, the control cable needs adjustment.

1. Place selector lever in "P" position.
2. Loosen control cable lock nut and place manual shaft in "P" position.
3. Pull control cable in the direction of the arrow shown in the illustration by specified force.  
**Specified force: 6.9 N (0.7 kg, 1.5 lb)**
4. Return control cable in the opposite direction of the arrow for 1.0 mm (0.039 in).
5. Tighten control cable lock nut.
6. Move selector lever from "P" to "1" position again. Make sure that selector lever moves smoothly.
7. Apply grease to contacting areas of selector lever and control cable. Install any part removed.

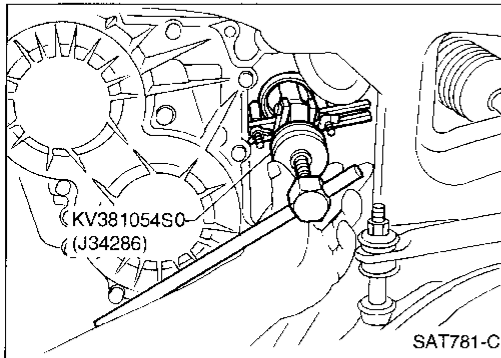

## Differential Side Oil Seal Replacement

1. Remove drive shaft assembly. — Refer to FA section ("Drive Shaft", "FRONT AXLE").
2. Remove oil seal.

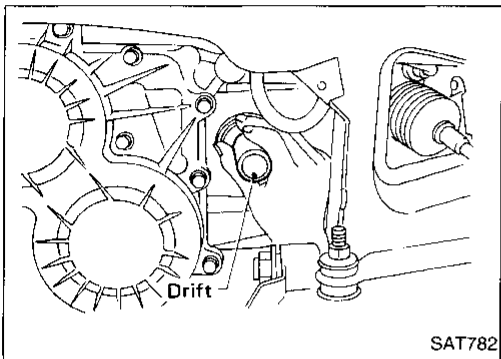

3. Install oil seal.  
**Apply ATF before installing.**
4. Reinstall any part removed.

# REMOVAL AND INSTALLATION

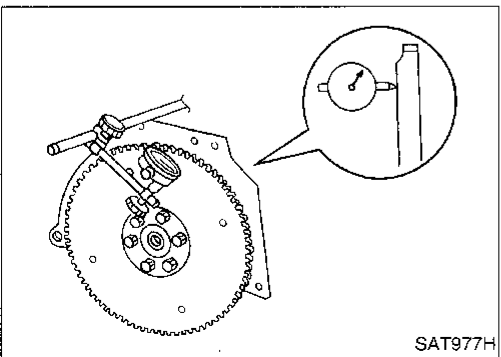
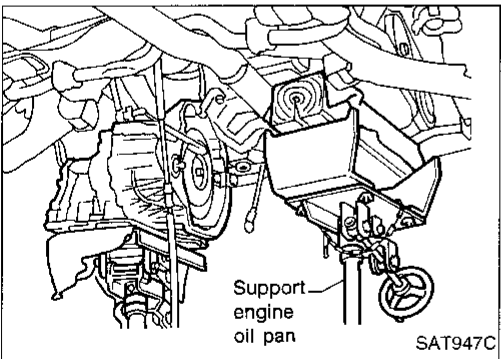
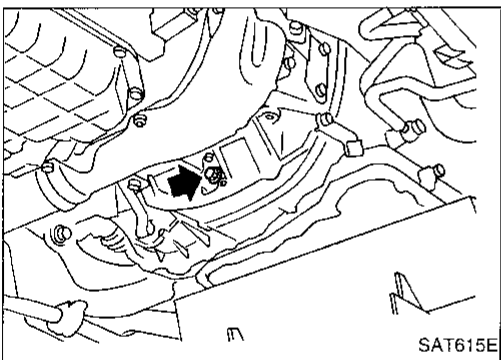
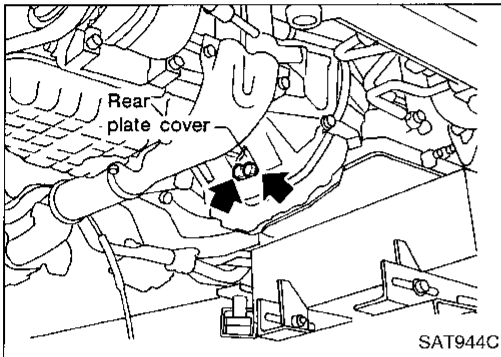
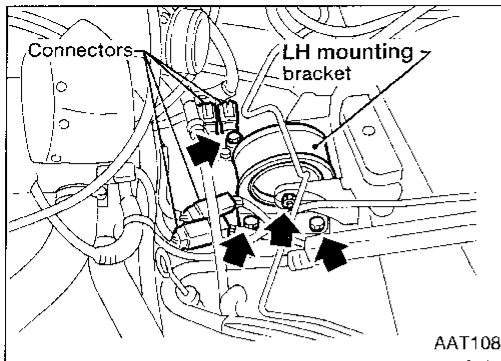

## Removal

### CAUTION:

When removing the transaxle assembly from engine, first remove the crankshaft position sensor (POS) from the assembly.

Be careful not to damage sensor edge.

- Remove battery and bracket.
- Remove air cleaner and resonator.
- Disconnect terminal cord assembly harness connector and inhibitor switch harness connectors.
- Disconnect harness connectors of revolution sensor and vehicle speed sensor.
- Remove crankshaft position sensor (POS) from transaxle.
- Remove LH mounting bracket from transaxle and body.
- Disconnect control cable at transaxle side.
- Drain ATF.
- Remove drive shafts. Refer to FA section ("Drive Shaft", "FRONT AXLE").
- Disconnect oil cooler piping.
- Remove starter motor from transaxle.
- Support engine by placing a jack under oil pan.

Do not place jack under oil pan drain plug.

- Remove center member.
- Remove rear plate cover and bolts securing torque converter to drive plate.

Rotate crankshaft for access to securing bolts.

- Support transaxle with a jack.
- Remove bolts fixing A/T to engine.
- Lower transaxle while supporting it with a jack.

## Installation

- Drive plate runout

### CAUTION:

Do not allow any magnetic materials to contact the ring gear teeth.

Maximum allowable runout:

Refer to EM section ("Inspection", "CYLINDER BLOCK").

If this runout is out of allowance, replace drive plate with ring gear.

CI

MA

EM

LC

EC

FE

CL

MT

AT

FA

RA

BR

ST

RS

BT

HA

EL

IDX

# REMOVAL AND INSTALLATION

## Installation (Cont'd)

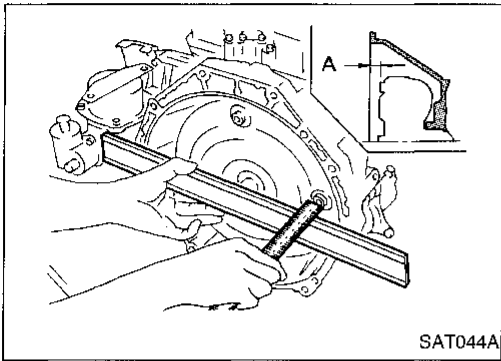

- When connecting torque converter to transaxle, measure distance "A" to be certain that they are correctly assembled.  
**Distance "A":**  
**14 mm (0.55 in) or more**

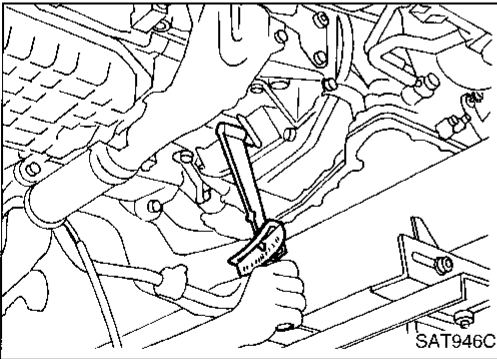

- Install bolts fixing converter to drive plate.
- With converter installed, rotate crankshaft several turns to check that transaxle rotates freely without binding.**

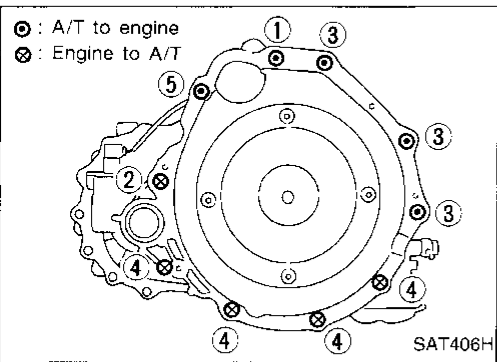

- Tighten bolt securing transaxle.

Bolt No.	Tightening torque N-m (kg-m, ft-lb)	mm (in)
①	70 - 79 (7.1 - 8.1, 51 - 59)	65 (2.56)
②	70 - 79 (7.1 - 8.1, 51 - 59)	52 (2.05)
③	70 - 79 (7.1 - 8.1, 51 - 59)	52 (2.05)
④	70 - 79 (7.1 - 8.1, 51 - 59)	40 (1.57)
⑤	70 - 79 (7.1 - 8.1, 51 - 59)	124 (4.88)

- Reinstall any part removed.

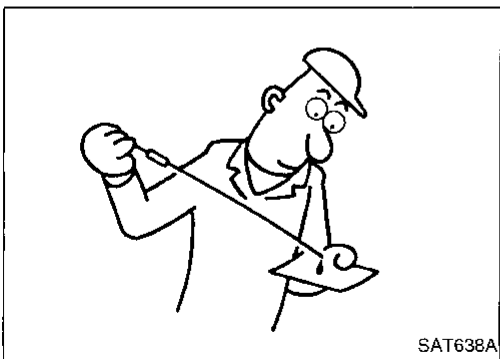

- Check fluid level in transaxle.
- Move selector lever through all positions to be sure that transaxle operates correctly.  
 With parking brake applied, rotate engine at idling. Move selector lever through "N" to "D", to "2", to "1" and to "R" position. A slight shock should be felt by hand gripping selector each time transaxle is shifted.
- Perform road test. Refer to AT-25.



# MAJOR OVERHAUL

SEC. 311-313-327-381

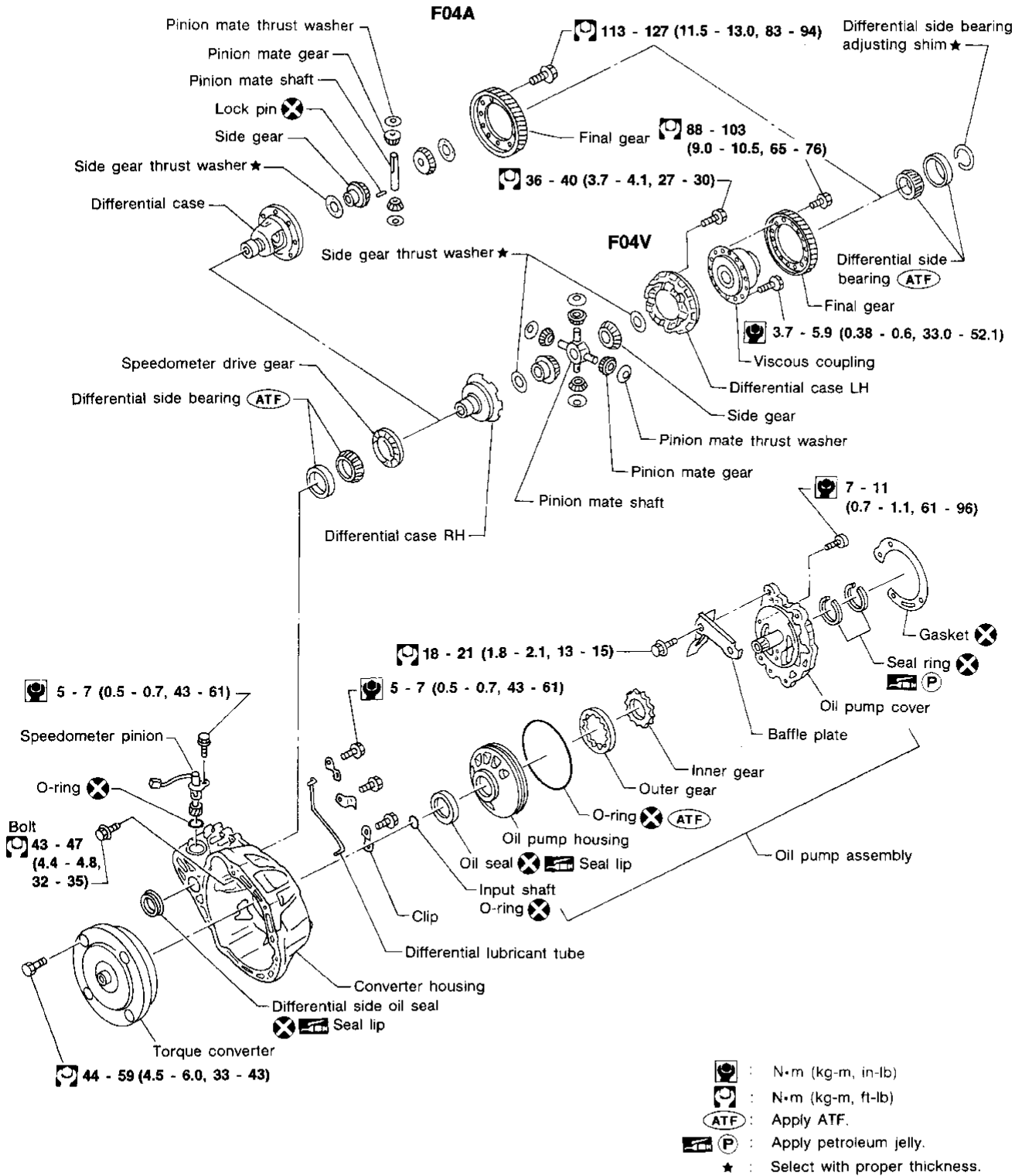

GI  
MA  
EM  
LC  
EC  
FE  
CL  
MT  
AT  
FA  
RA  
BR  
ST  
RS  
BT  
HA  
EL  
IDX



# MAJOR OVERHAUL

## SEC. 310-315-317-319

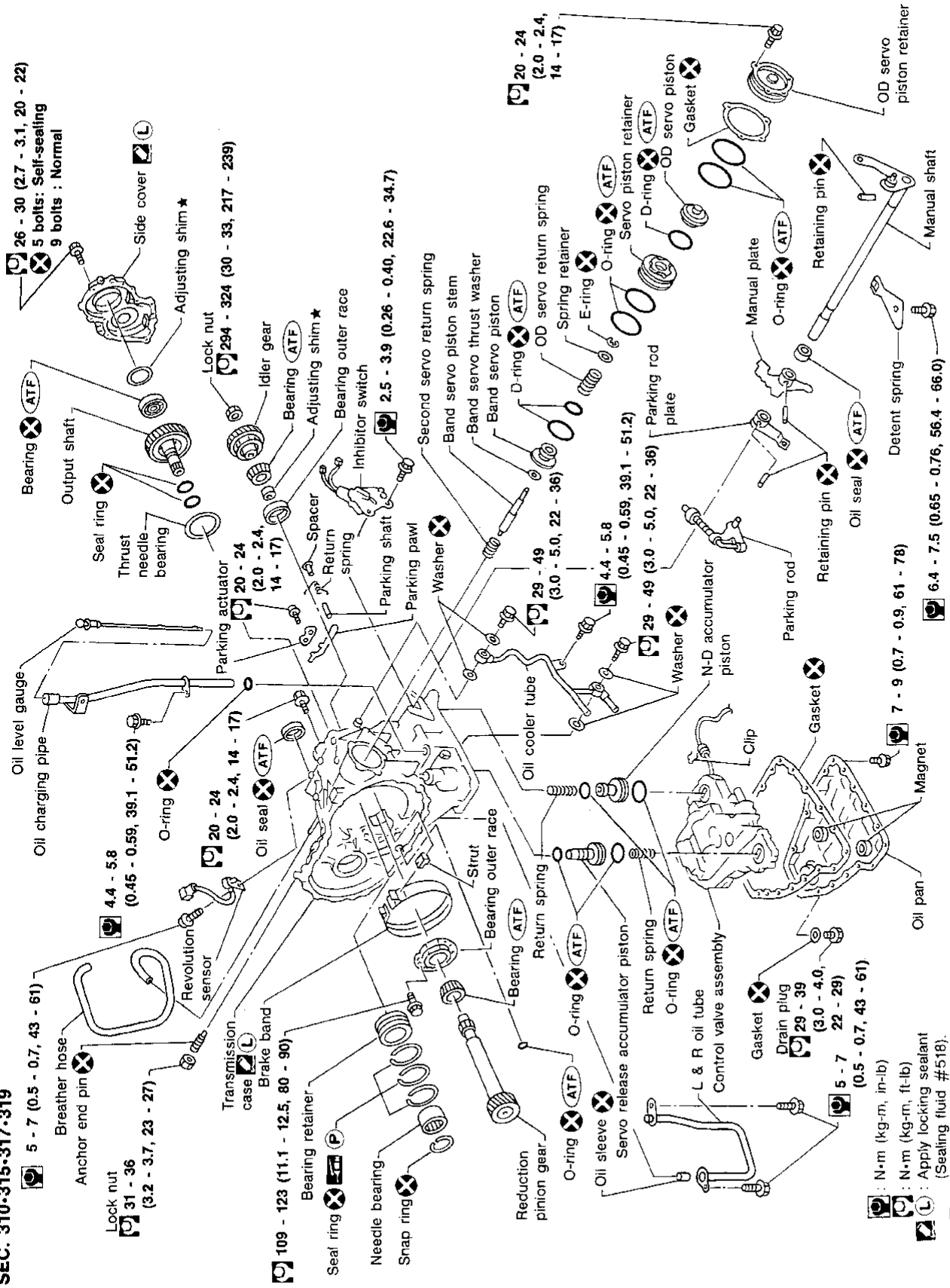

- : N.m (kg-m, in-lb)
- : N.m (kg-m, ft-lb)
- : Apply locking sealant (Sealing fluid #518).
- : Apply ATF.
- : Apply petroleum jelly.
- : Select with proper thickness.

CI  
 MA  
 EM  
 LC  
 EC  
 FE  
 CL  
 MT  
**AT**  
 FA  
 RA  
 BR  
 ST  
 RS  
 BT  
 HA  
 EL  
 IDX

# MAJOR OVERHAUL

## Oil Channel

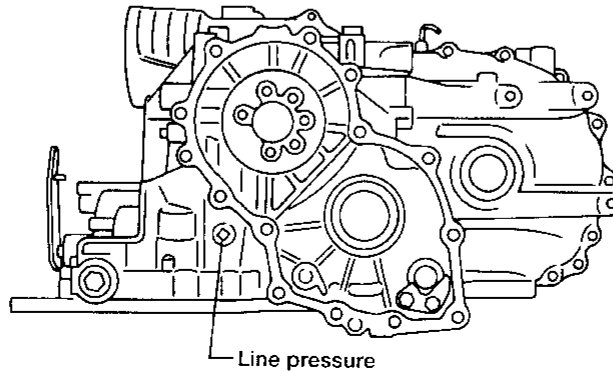
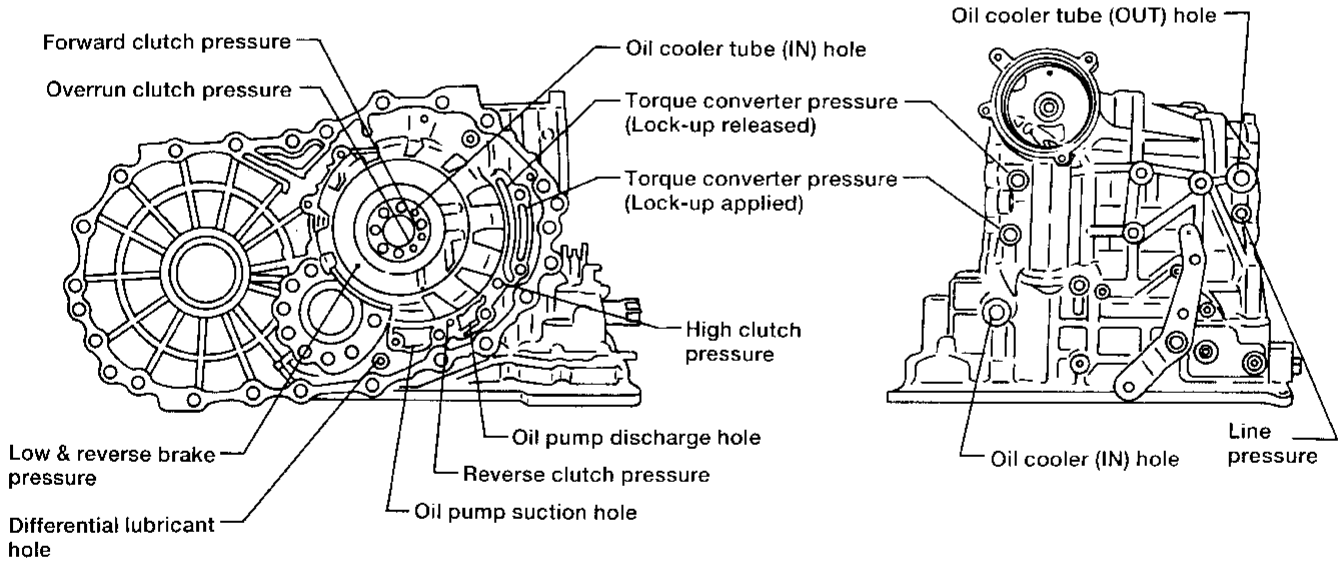
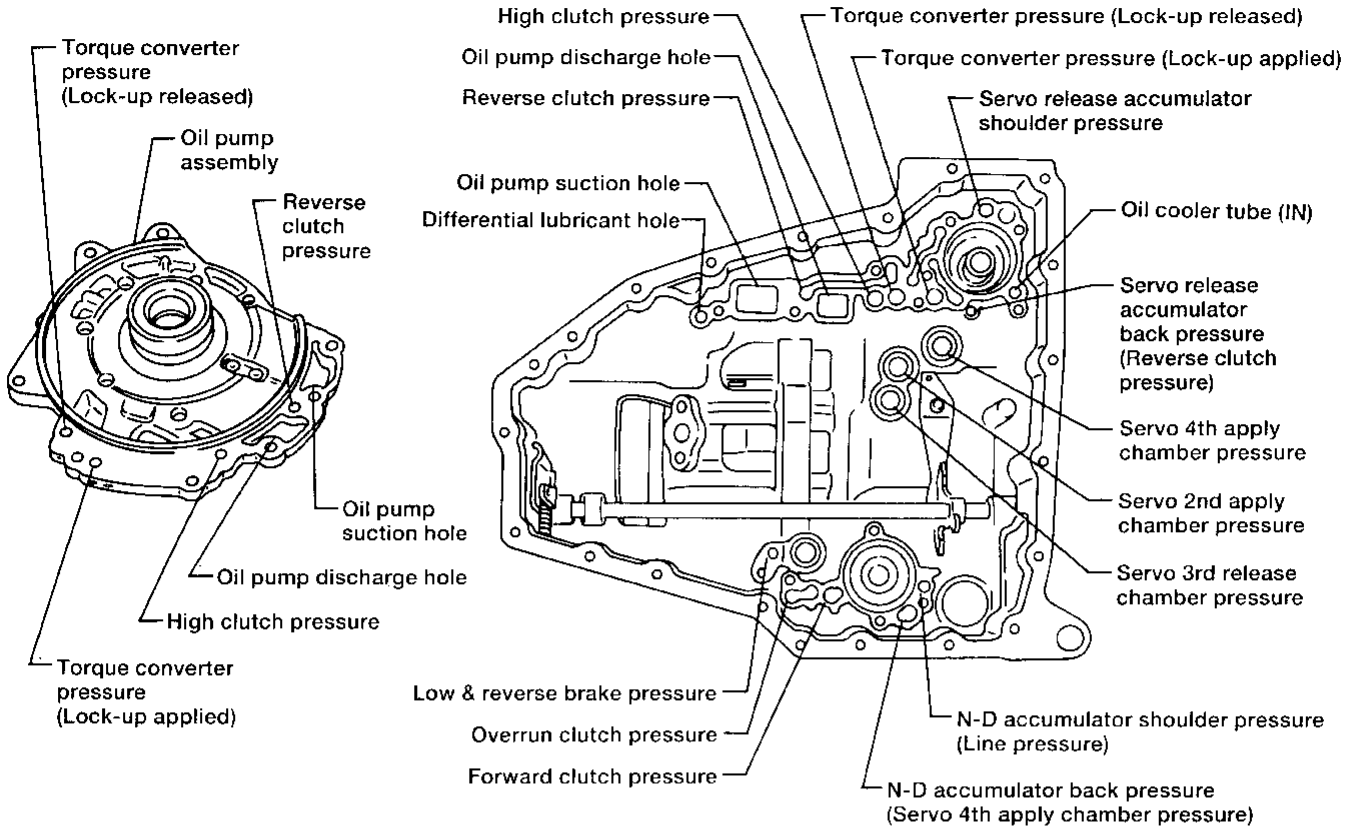

AAT307

# DISASSEMBLY

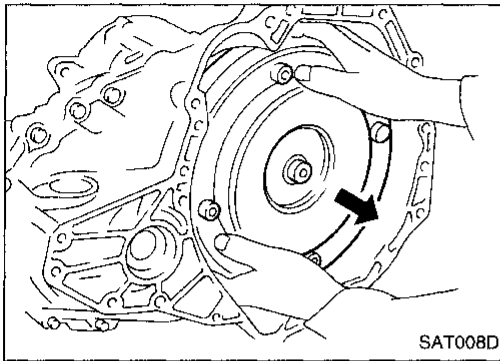

1. Drain ATF through drain plug.
2. Remove torque converter.

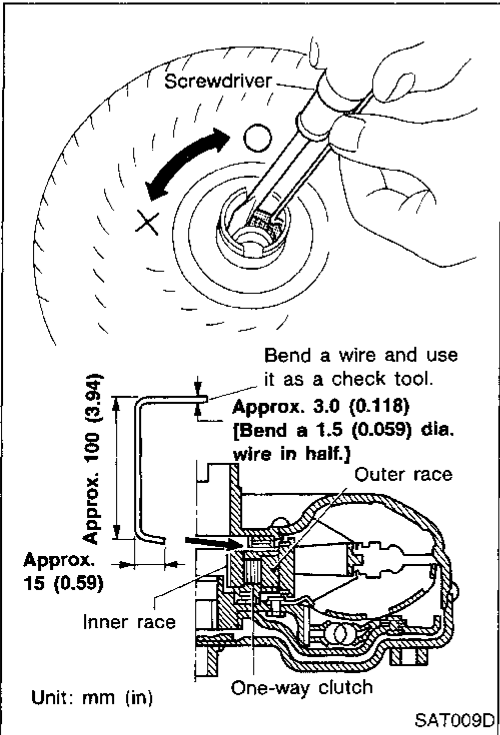

3. Check torque converter one-way clutch using check tool as shown at left.
  - a. Insert check tool into the groove of bearing support built into one-way clutch outer race.
  - b. When fixing bearing support with check tool, rotate one-way clutch spline using screwdriver.
  - c. Check that inner race rotates clockwise only. If not, replace torque converter assembly.

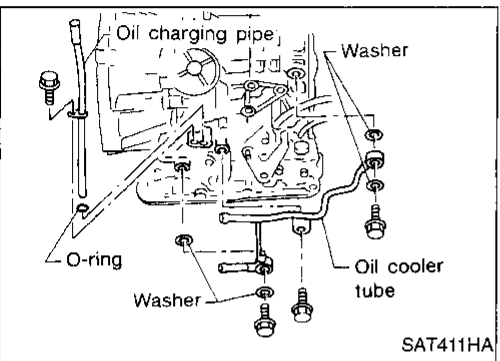

4. Remove oil charging pipe and oil cooler tube.

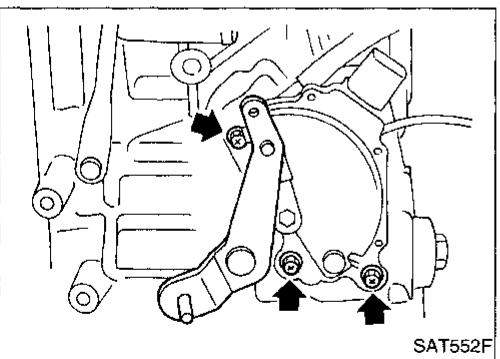

5. Set manual shaft to position "P".
6. Remove inhibitor switch.

GI

MA

EM

LC

EC

FE

CL

MT

AT

FA

RA

BR

ST

RS

BT

HA

EL

IDX

## DISASSEMBLY

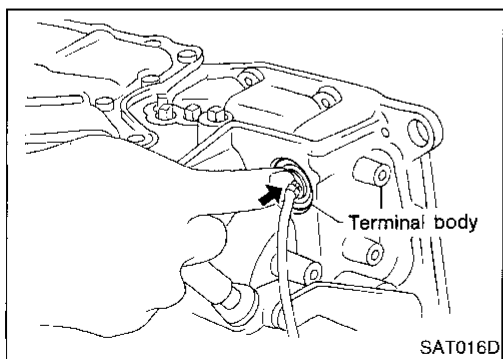
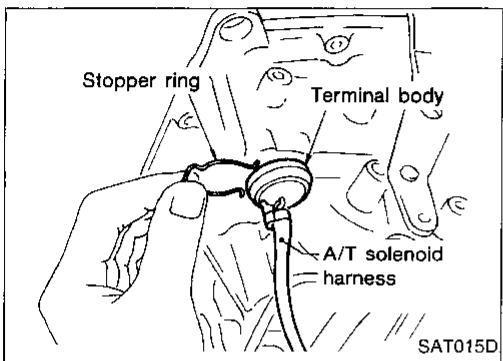
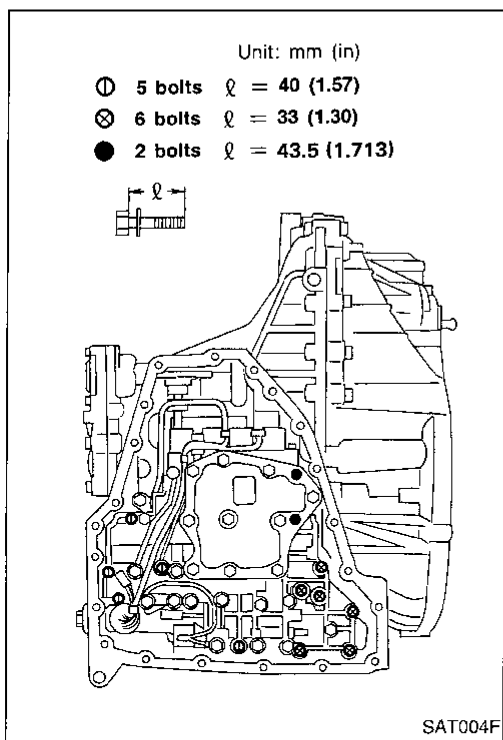
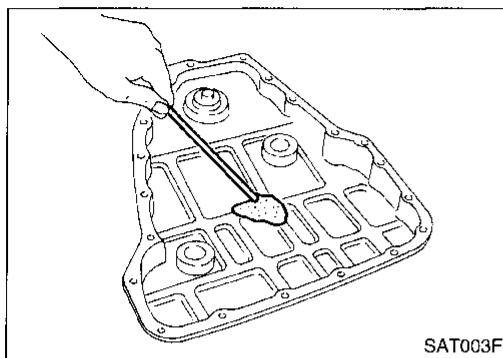

7. Remove oil pan and oil pan gasket.
  - **Do not reuse oil pan bolts.**
8. Check foreign materials in oil pan to help determine causes of malfunction. If the fluid is very dark, smells burned, or contains foreign particles, the frictional material (clutches, band) may need replacement. A tacky film that will not wipe clean indicates varnish build up. Varnish can cause valves, servo, and clutches to stick and may inhibit pump pressure.
  - **If frictional material is detected, replace radiator after repair of A/T. Refer to LC section ("Radiator", "ENGINE COOLING SYSTEM").**

9. Remove control valve assembly according to the following procedures.

- a. Remove control valve assembly mounting bolts ①, ⊗ and ●.

- b. Remove stopper ring from terminal body.

- c. Push terminal body into transmission case and draw out solenoid harness.

# DISASSEMBLY

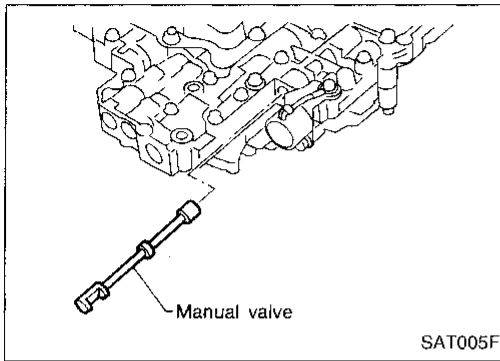

10. Remove manual valve from control valve assembly.

GI

HA

EM

LC

EC

FE

CL

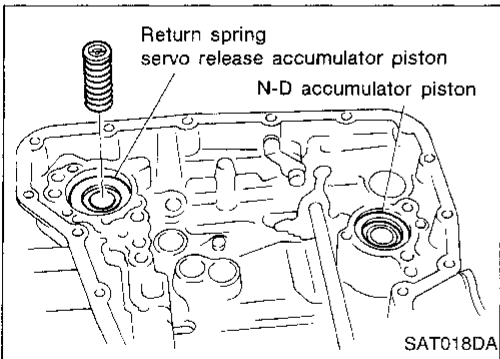

11. Remove return spring from servo release accumulator piston.

MT

AT

FA

RA

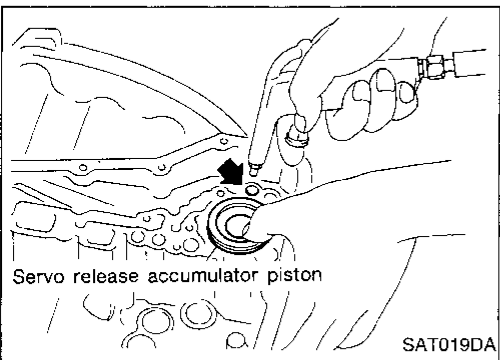

12. Remove servo release accumulator piston with compressed air.

13. Remove O-rings from servo release accumulator piston.

BR

ST

RS

BT

HA

EL

IDX

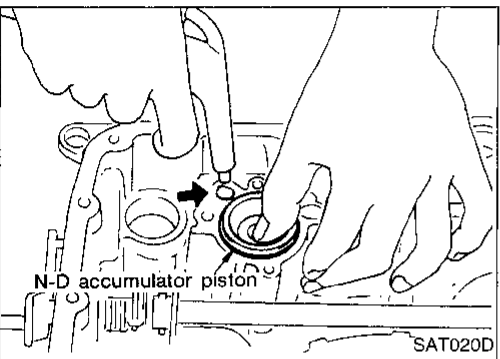

14. Remove N-D accumulator piston and return spring with compressed air.

15. Remove O-rings from N-D accumulator piston.

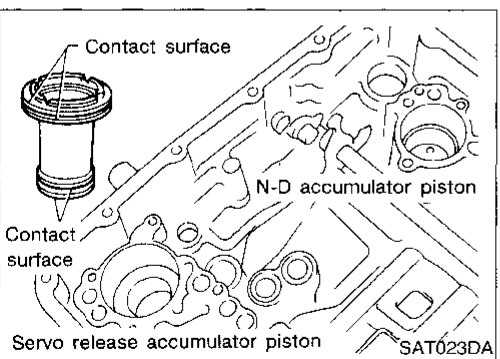

16. Check accumulator pistons and contact surface of transmission case for damage.

17. Check accumulator return springs for damage and free length.

## DISASSEMBLY

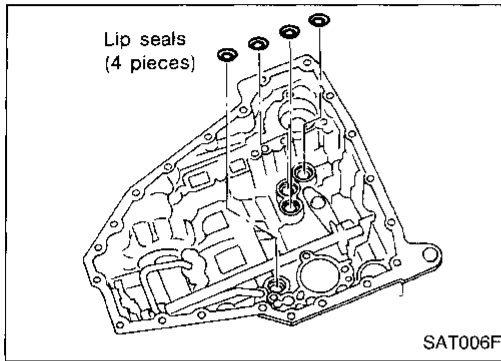

18. Remove lip seals.

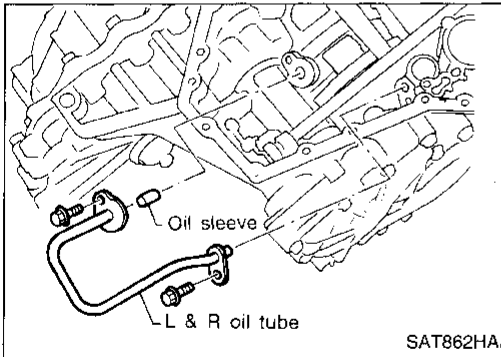

19. Remove L & R oil tube and oil sleeve.

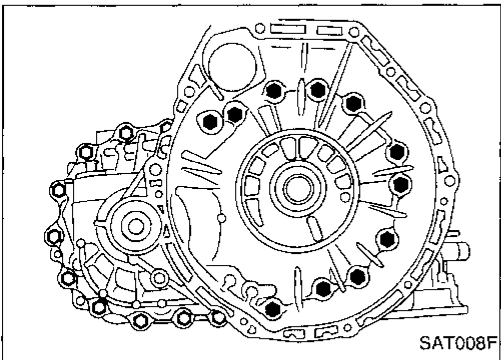

20. Remove converter housing according to the following procedures.

- a. Remove converter housing mounting bolts.
- b. Remove converter housing by tapping it lightly.

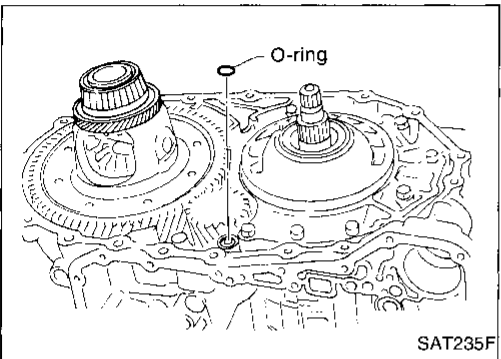

c. Remove O-ring from differential oil port.

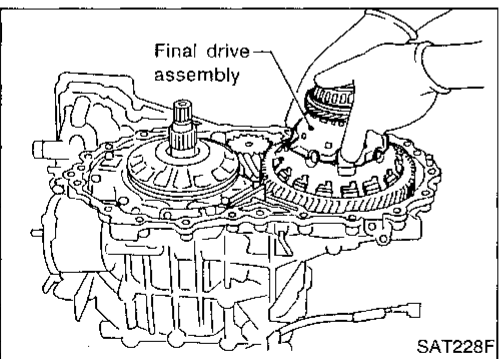

21. Remove final drive assembly from transmission case.



# DISASSEMBLY

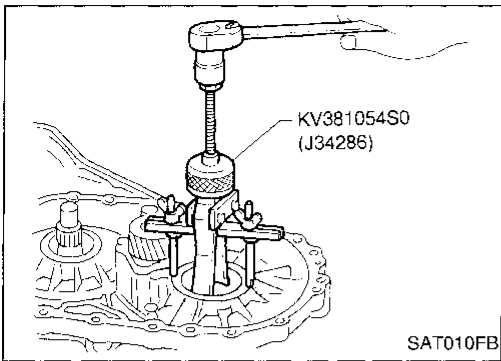

22. Remove differential side bearing outer race from transmission case.

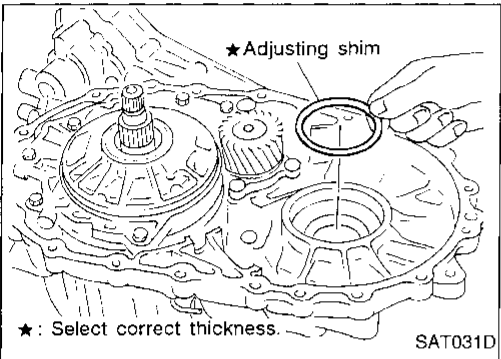

23. Remove differential side bearing adjusting shim from transmission case.

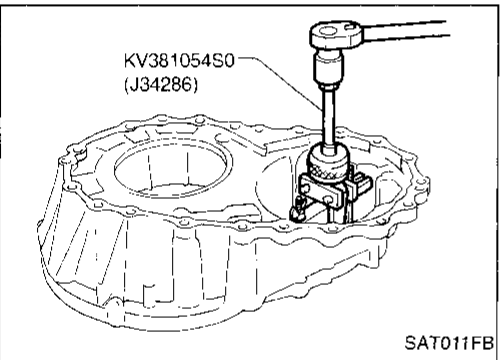

24. Remove differential side bearing outer race from converter housing.

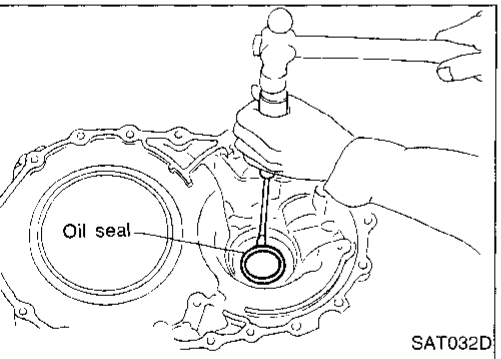

25. Remove oil seal with screwdriver from converter housing.  
 • **Be careful not to damage case.**

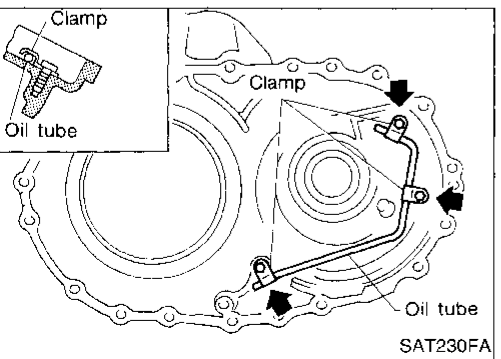

26. Remove oil tube from converter housing.

GI

MA

EM

LC

EC

FE

CL

MT

AT

FA

RA

BR

ST

RS

BT

HA

EL

IDX

## DISASSEMBLY

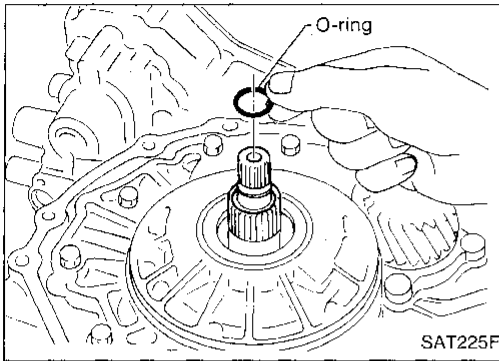

27. Remove oil pump according to the following procedures.
- Remove O-ring from input shaft.

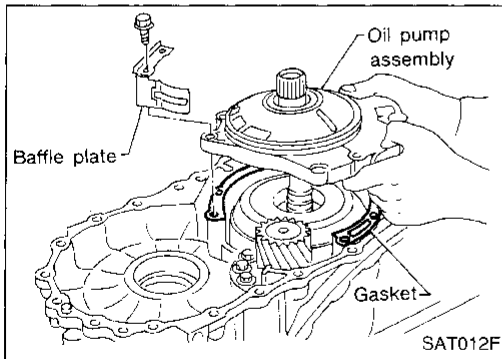

- Remove oil pump assembly, baffle plate and gasket from transmission case.

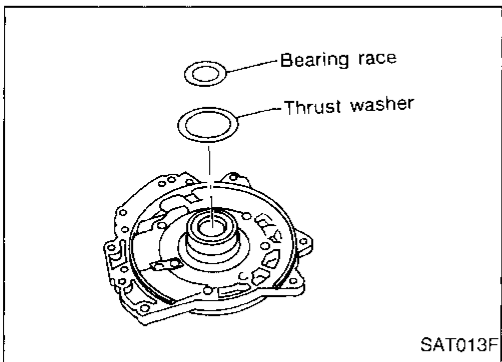

- Remove thrust washer and bearing race from oil pump assembly.

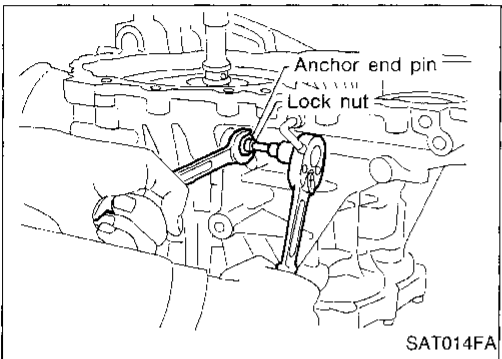

28. Remove brake band according to the following procedures.
- Loosen lock nut, then back off anchor end pin.
    - Do not reuse anchor end pin.**

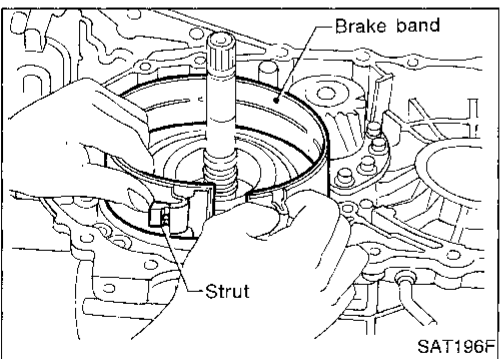

- Remove brake band and strut from transmission case.

# DISASSEMBLY

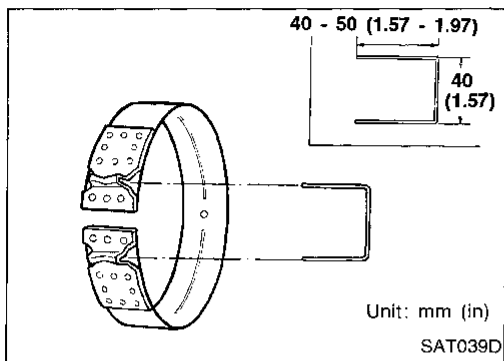

- To prevent brake linings from cracking or peeling, do not stretch the flexible band unnecessarily. When removing the brake band, always secure it with a clip as shown in the figure at left. Leave the clip in position after removing the brake band.

GI

MA

EM

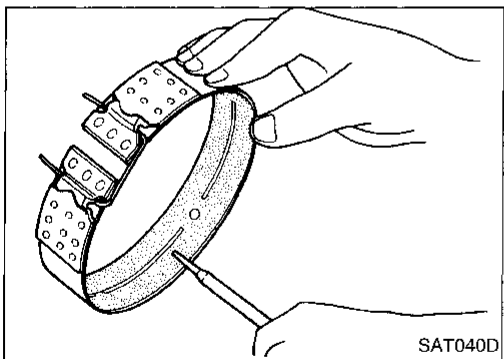

- Check brake band facing for damage, cracks, wear or burns.

LC

EC

FE

CL

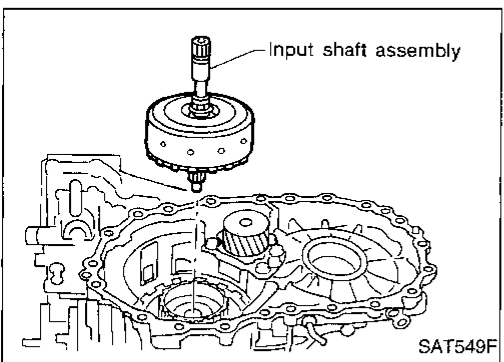

- Remove input shaft assembly (high clutch) and reverse clutch according to the following procedures.

- Remove input shaft assembly (high clutch) with reverse clutch.

MT

AT

FA

RA

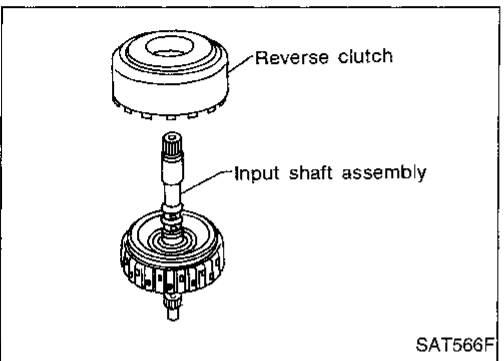

- Remove input shaft assembly (high clutch) from reverse clutch.

BR

ST

RS

BT

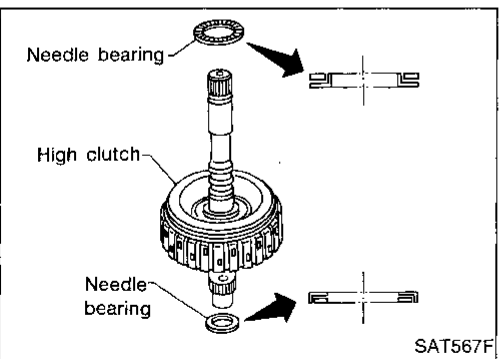

- Remove needle bearings from high clutch drum and check for damage or wear.

HA

EL

IDX

## DISASSEMBLY

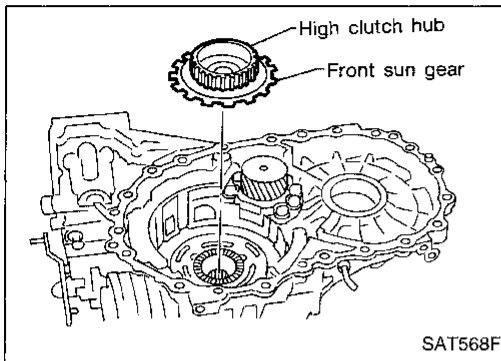

- d. Remove high clutch hub and front sun gear from transmission case.

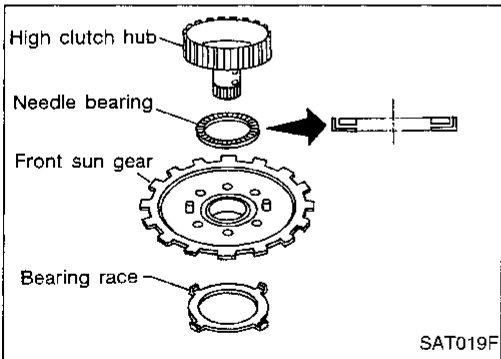

- e. Remove front sun gear and needle bearing from high clutch hub and check for damage or wear.  
f. Remove bearing race from front sun gear and check for damage or wear.

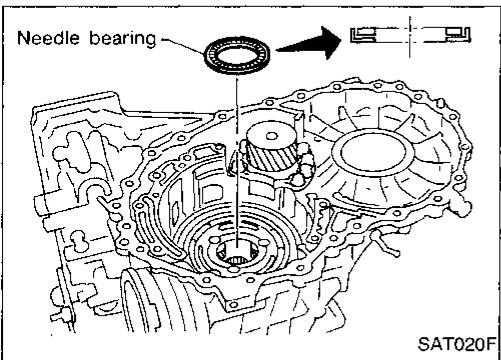

30. Remove needle bearing from transmission case and check for damage or wear.

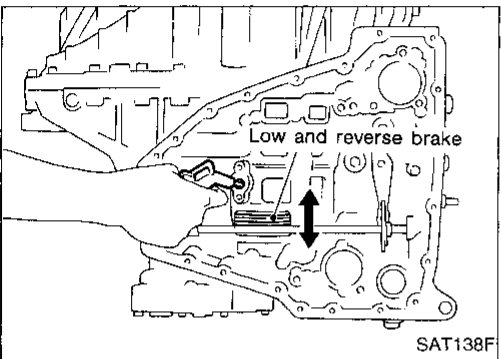

31. Apply compressed air and check to see that low and reverse brake operates.

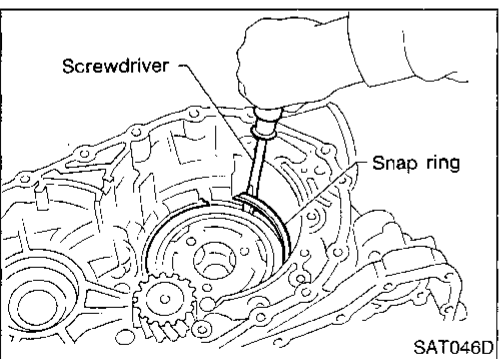

32. Remove low one-way clutch and front planetary carrier assembly according to the following procedures.  
a. Remove snap ring with flat-bladed screwdriver.

# DISASSEMBLY

- b. Remove low one way clutch with a hook made of wire.

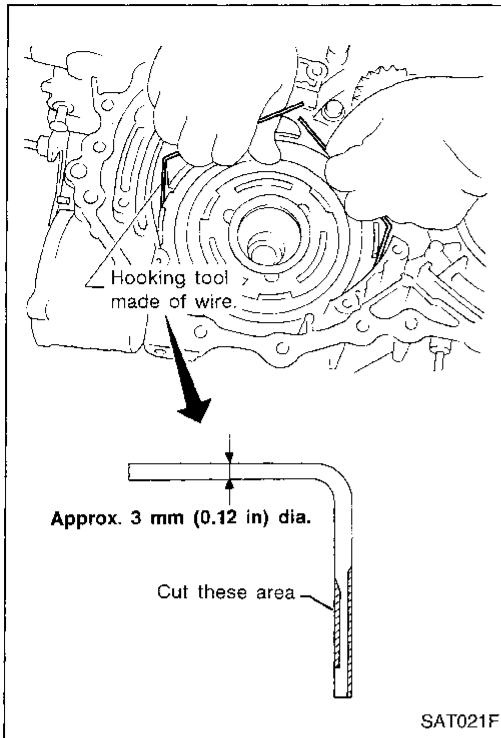

- c. Remove snap ring with flat-bladed screwdriver.

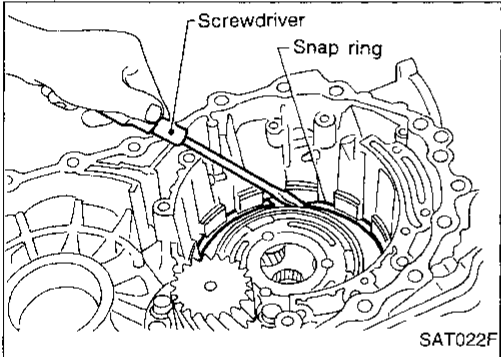

- d. Remove front planetary carrier with low and reverse brake piston and retainer.

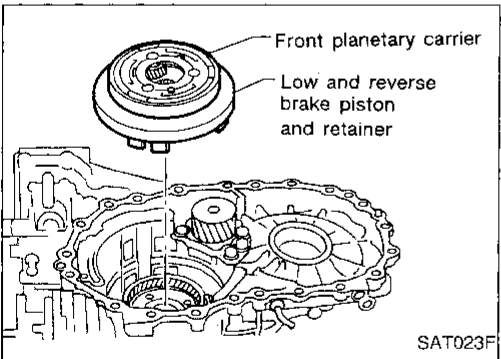

- e. Remove low and reverse brake spring retainer.
- Do not remove return springs from spring retainer.

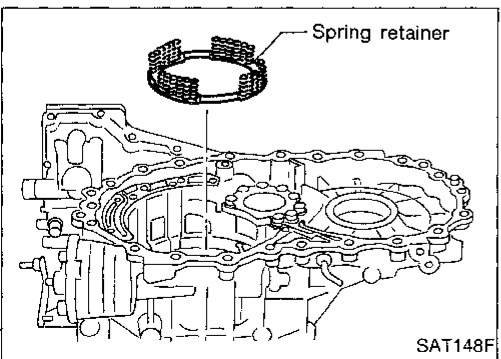

GI

MA

EM

LC

EC

FE

CL

MT

AT

FA

RA

BR

ST

RS

BT

HA

EL

IDX

## DISASSEMBLY

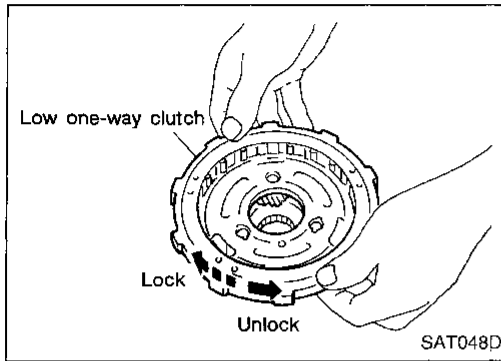

- f. Check that low one-way clutch rotates in the direction of the arrow and locks in the opposite direction.

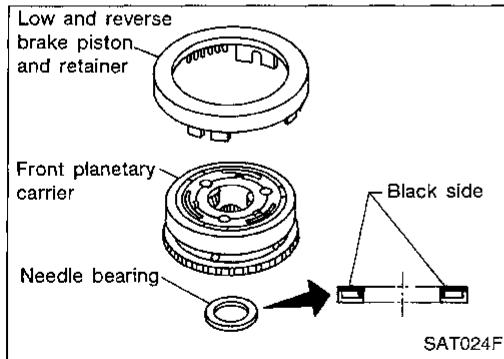

- g. Remove needle bearing, low and reverse brake piston and retainer from front planetary carrier.

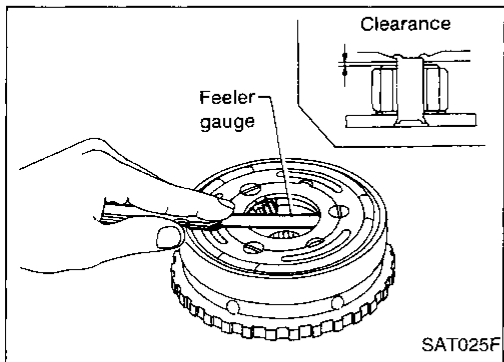

- h. Check front planetary carrier, low one-way clutch and needle bearing for damage or wear.
- i. Check clearance between planetary gears and planetary carrier with feeler gauge.

**Standard clearance:**

**0.20 - 0.70 mm (0.0079 - 0.0276 in)**

**Allowable limit:**

**0.80 mm (0.0315 in)**

Replace front planetary carrier if the clearance exceeds allowable limit.

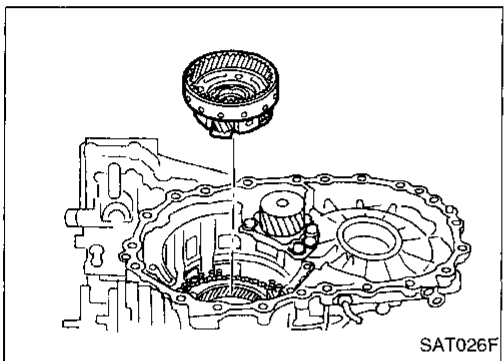

33. Remove rear planetary carrier assembly and rear sun gear according to the following procedures.

- a. Remove rear planetary carrier assembly from transmission case.

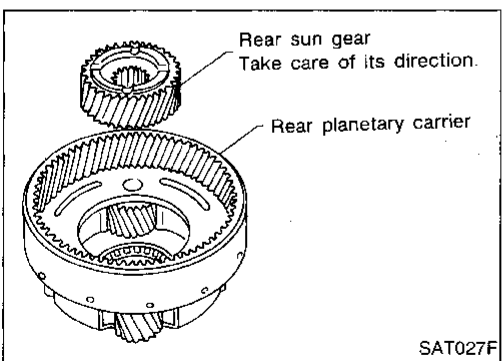

- b. Remove rear sun gear from rear planetary carrier.

# DISASSEMBLY

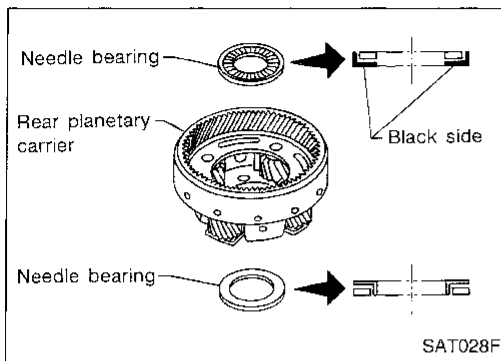

c. Remove needle bearings from rear planetary carrier assembly.

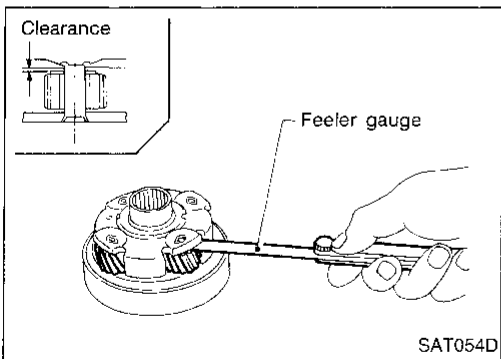

d. Check rear planetary carrier, rear sun gear and needle bearings for damage or wear.

e. Check clearance between pinion washer and rear planetary carrier with feeler gauge.

**Standard clearance:**

**0.20 - 0.70 mm (0.0079 - 0.0276 in)**

**Allowable limit:**

**0.80 mm (0.0315 in)**

Replace rear planetary carrier if the clearance exceeds allowable limit.

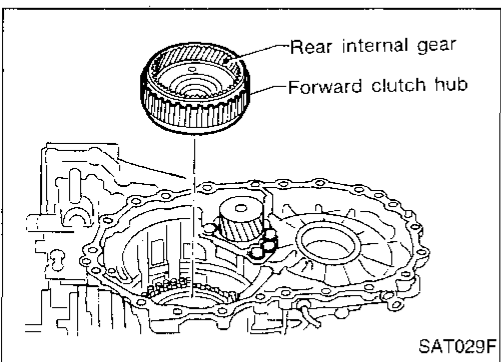

34. Remove rear internal gear and forward clutch hub from transmission case.

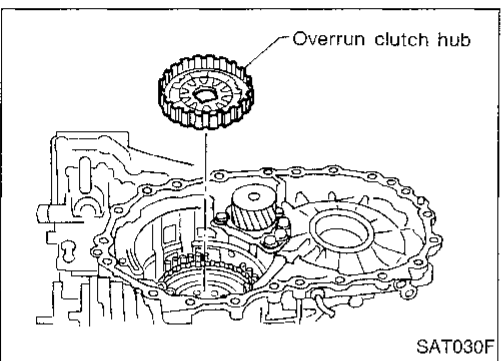

35. Remove overrun clutch hub from transmission case.

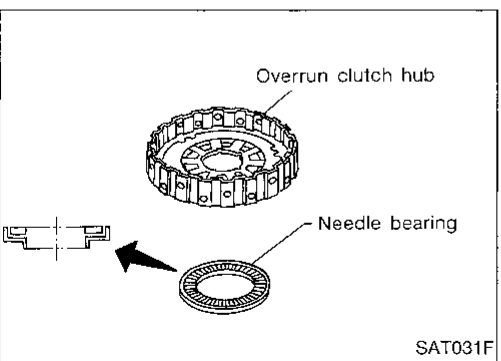

36. Remove needle bearing from overrun clutch hub and check for damage or wear.

GI

MA

EM

LC

EC

FE

CL

MT

AT

FA

RA

BR

ST

RS

BT

HA

EL

IDX

## DISASSEMBLY

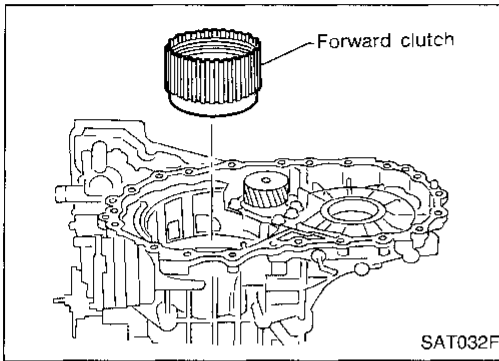

37. Remove forward clutch assembly from transmission case.

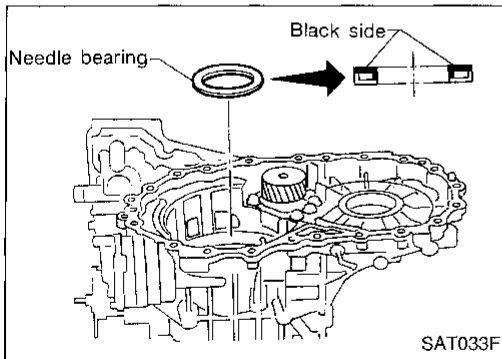

38. Remove needle bearing from transmission case.

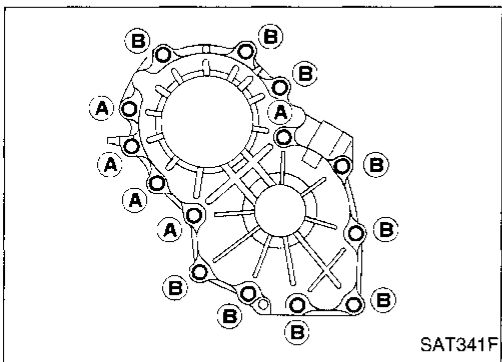

39. Remove output shaft assembly according to the following procedures.

a. Remove side cover bolts.

- **Do not mix bolts (A) and (B).**
- **Always replace bolts (A) as they are self-sealing bolts.**

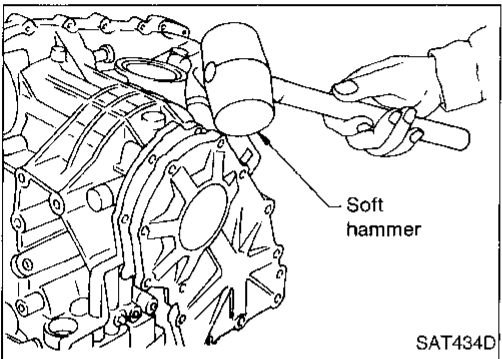

b. Remove side cover by lightly tapping it with a soft hammer.

- **Be careful not to drop output shaft assembly. It might come out when removing side cover.**

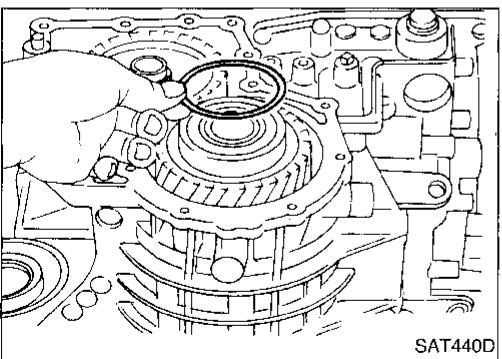

c. Remove adjusting shim.



## DISASSEMBLY

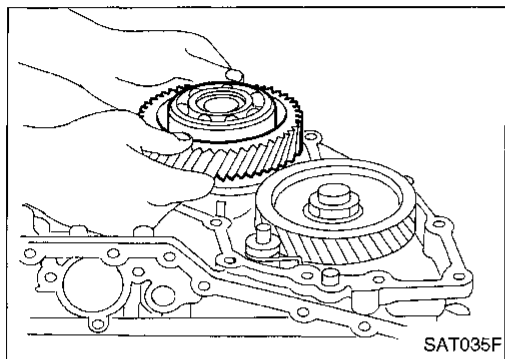

d. Remove output shaft assembly.

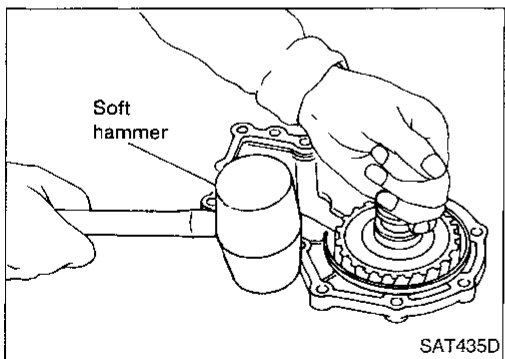

- If output shaft assembly came off with side cover, tap cover with a soft hammer to separate.

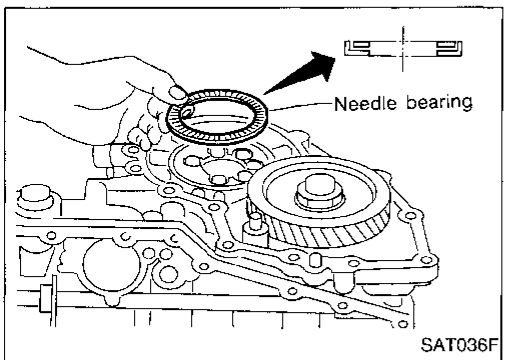

e. Remove needle bearing.

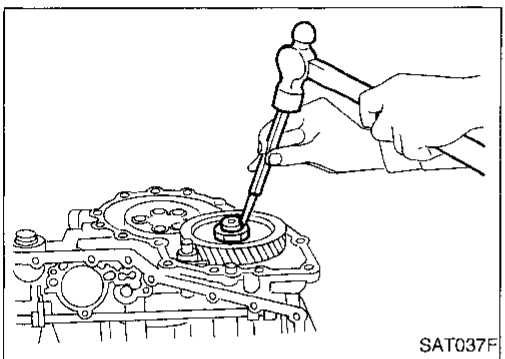

40. Disassemble reduction pinion gear according to the following procedures.

- Set manual lever to position "P" to fix idler gear.
- Unlock idler gear lock nut using a pin punch.

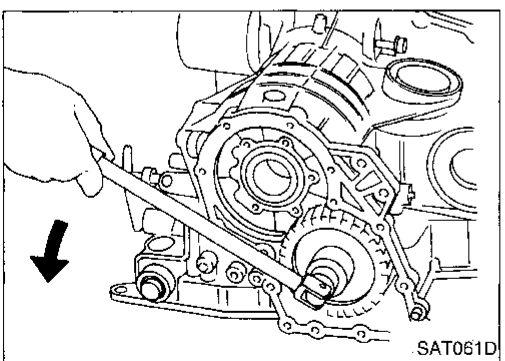

c. Remove idler gear lock nut.

- **Do not reuse idler gear lock nut.**

GI

MA

EM

LC

EC

FE

CL

MT

AT

FA

RA

BR

ST

RS

BT

HA

EL

IDX

# DISASSEMBLY

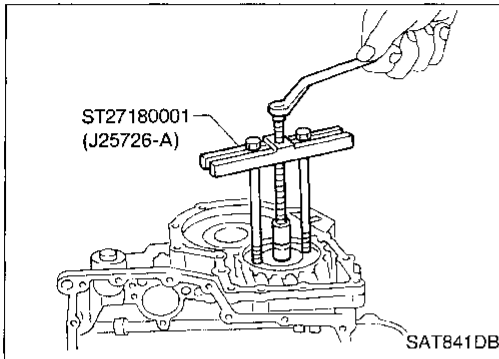

d. Remove idler gear with puller.

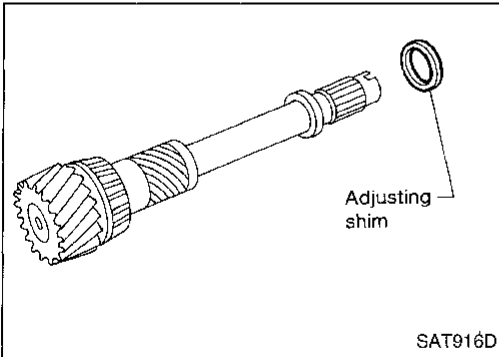

e. Remove reduction pinion gear.

f. Remove adjusting shim from reduction pinion gear.

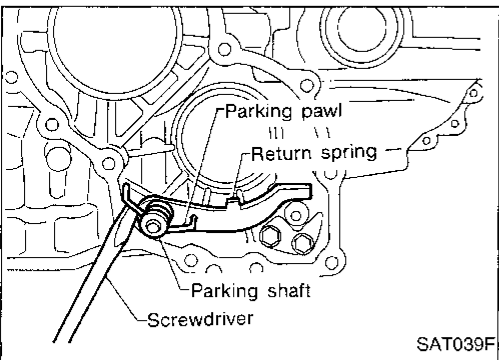

41. Remove return spring from parking shaft with screwdriver.

42. Draw out parking shaft and remove parking pawl from transmission case.

43. Check parking pawl and shaft for damage or wear.

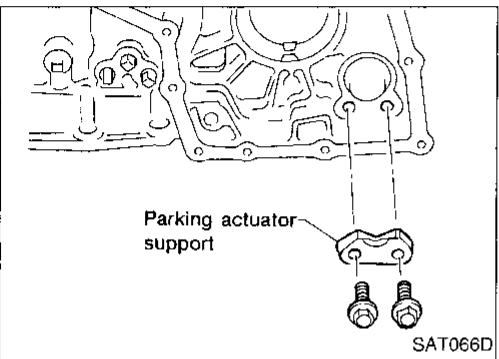

44. Remove parking actuator support from transmission case.

45. Check parking actuator support for damage or wear.

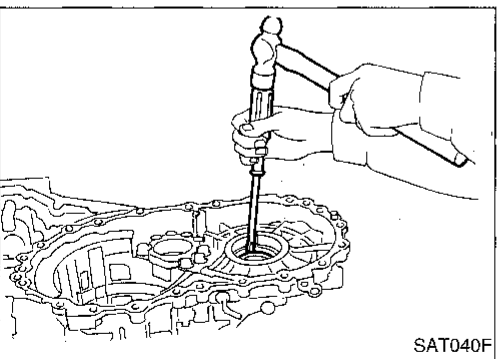

46. Remove side oil seal with screwdriver from transmission case.

## Manual Shaft

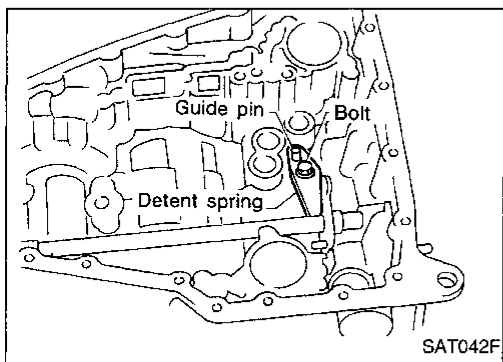
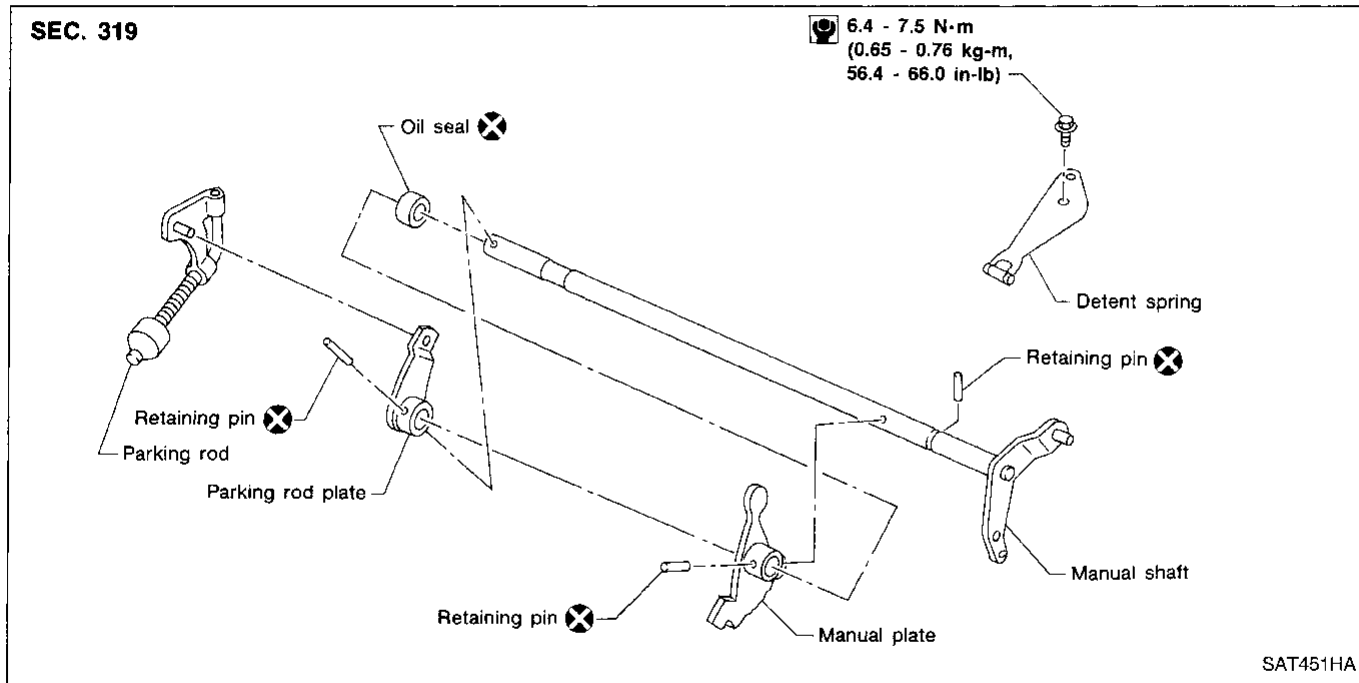

### REMOVAL

1. Remove detent spring from transmission case.

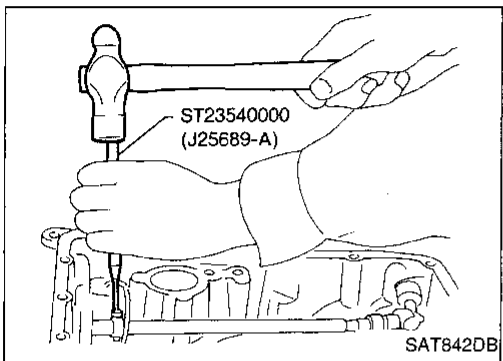

2. Drive out manual plate retaining pin.

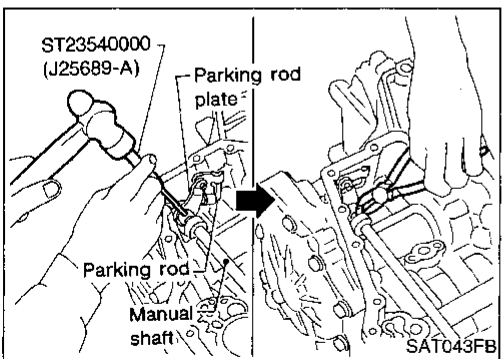

3. Drive and pull out parking rod plate retaining pin.
4. Remove parking rod plate from manual shaft.
5. Draw out parking rod from transmission case.

GI  
MA  
EM  
LC  
EC  
FE  
CL  
MT  
AT  
FA  
RA  
BR  
ST  
RS  
BT  
HA  
EL  
IDX

## REPAIR FOR COMPONENT PARTS

### Manual Shaft (Cont'd)

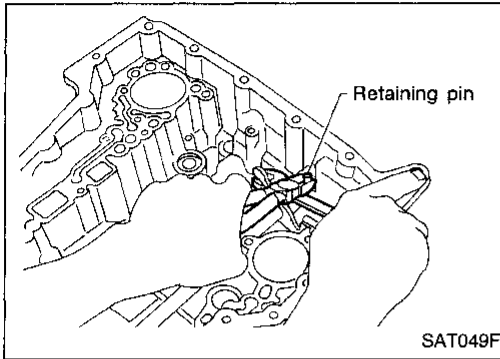

6. Pull out manual shaft retaining pin.
7. Remove manual shaft and manual plate from transmission case.

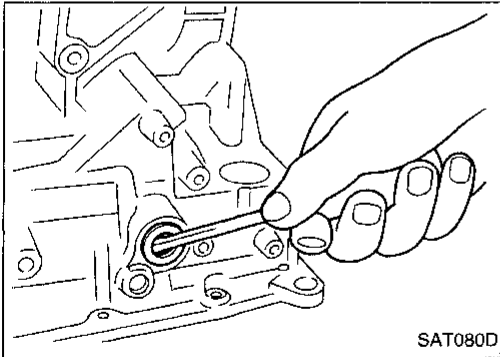

8. Remove manual shaft oil seal.

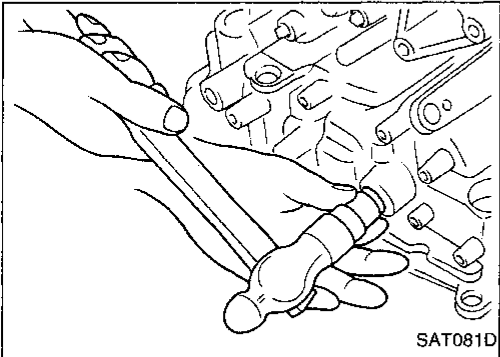

### INSPECTION

- Check component parts for wear or damage. Replace if necessary.

### INSTALLATION

1. Install manual shaft oil seal.
- **Apply ATF to outer surface of oil seal.**

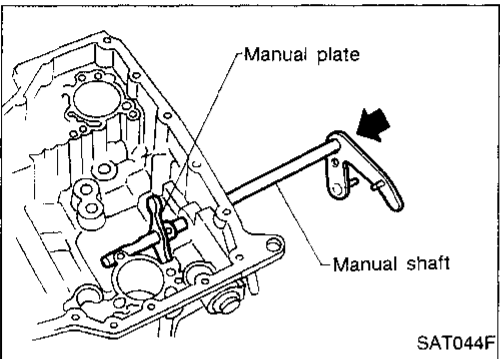

2. Install manual shaft and manual plate.

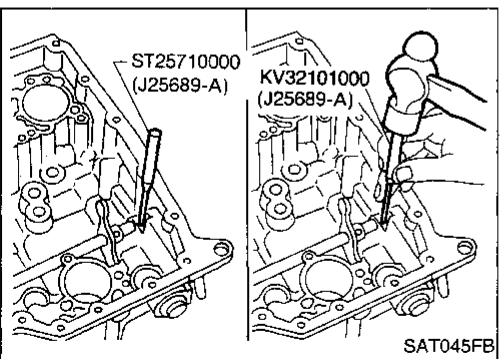

3. Align groove of manual shaft and hole of transmission case.
4. Install manual shaft retaining pin up to bottom of hole.

# REPAIR FOR COMPONENT PARTS

## Manual Shaft (Cont'd)

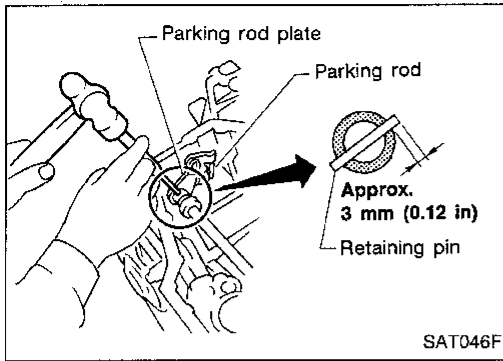

5. Install parking rod to parking rod plate.
6. Set parking rod assembly onto manual shaft and drive retaining pin.

Both ends of pin should protrude.

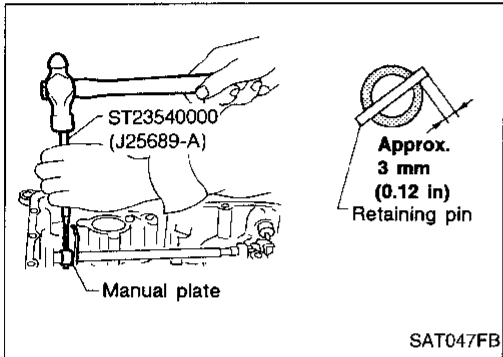

7. Drive manual plate retaining pin.
- Both ends of pin should protrude.

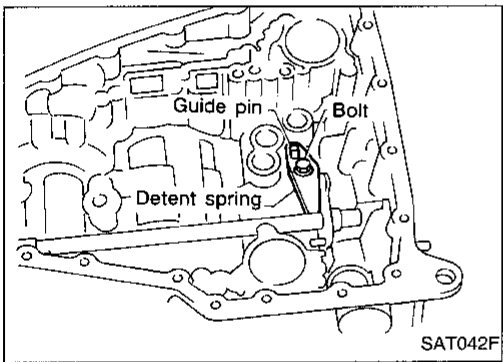

8. Install detent spring.

## Oil Pump

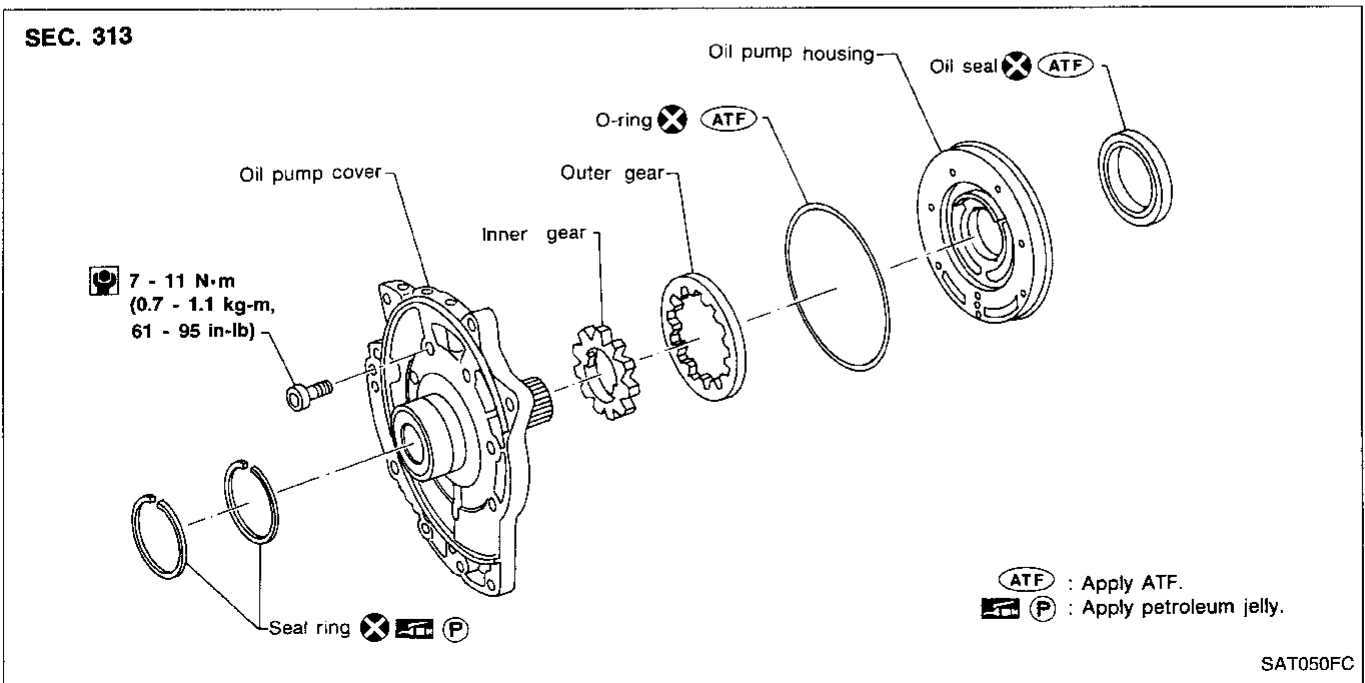

GI

MA

EM

LC

EC

FE

CL

MT

**AT**

FA

RA

BR

ST

RS

BT

HA

EL

IDX

## REPAIR FOR COMPONENT PARTS

### Oil Pump (Cont'd)

#### DISASSEMBLY

1. Remove seal rings.

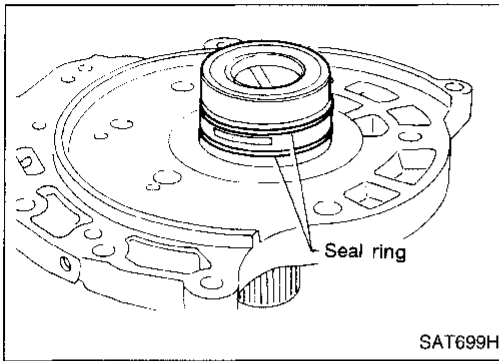

2. Loosen bolts in a crisscross pattern and remove oil pump cover.

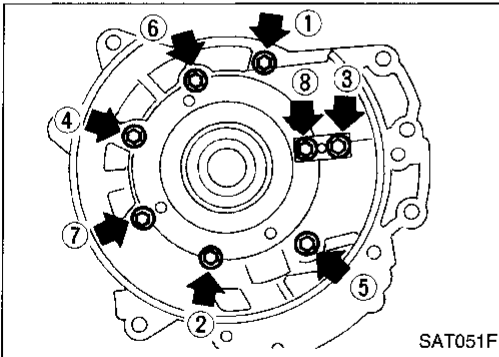

3. Remove inner and outer gear from oil pump housing.

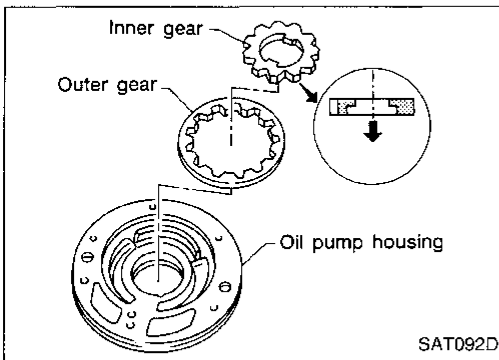

4. Remove O-ring from oil pump housing.

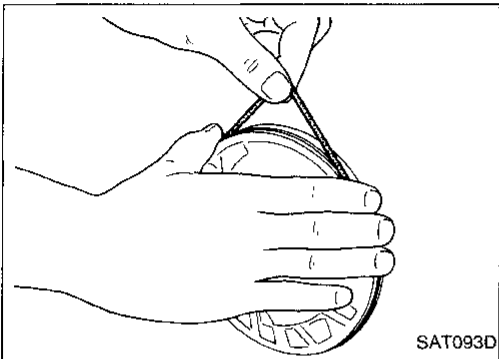

5. Remove oil pump housing oil seal.

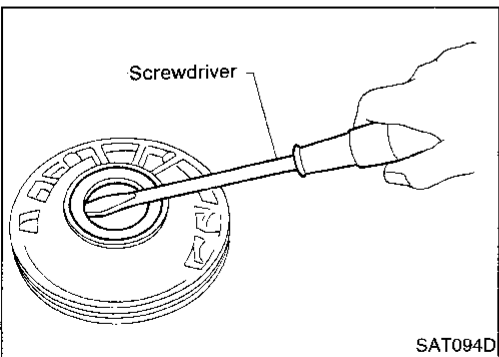

# REPAIR FOR COMPONENT PARTS

## Oil Pump (Cont'd)

### INSPECTION

Oil pump housing, oil pump cover, inner gear and outer gear

- Check for wear or damage.

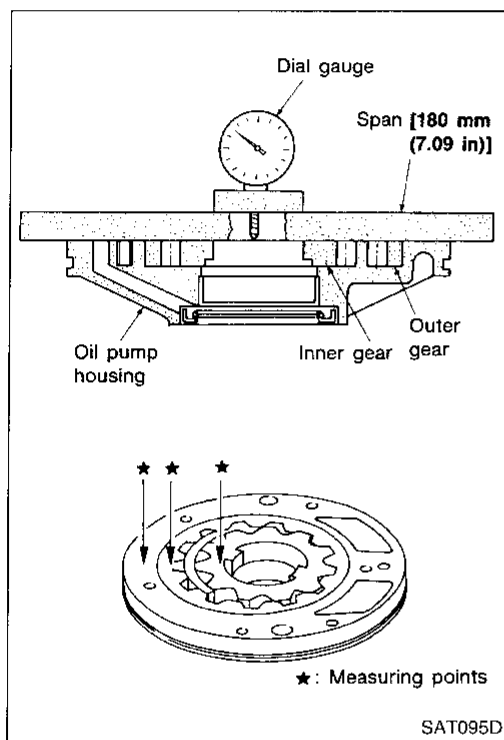

#### Side clearance

- Measure side clearance of inner and outer gears in at least four places around each outside edge. Maximum measured values should be within specified positions.

**Standard clearance:**

**0.030 - 0.050 mm (0.0012 - 0.0020 in)**

- If clearance is less than standard, select inner and outer gear as a set so that clearance is within specifications.

**Inner and outer gear:**

**Refer to SDS, AT-228.**

- If clearance is more than standard, replace whole oil pump assembly except oil pump cover.

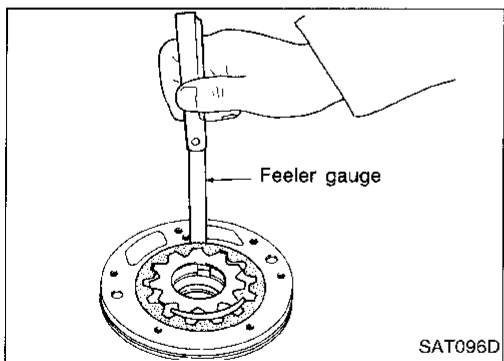

- Measure clearance between outer gear and oil pump housing.

**Standard clearance:**

**0.111 - 0.181 mm (0.0044 - 0.0071 in)**

**Allowable limit:**

**0.181 mm (0.0071 in)**

- If not within allowable limit, replace whole oil pump assembly except oil pump cover.

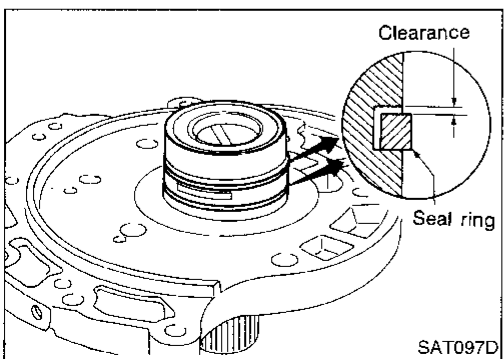

#### Seal ring clearance

- Measure clearance between seal ring and ring groove.

**Standard clearance:**

**0.1 - 0.25 mm (0.0039 - 0.0098 in)**

**Allowable limit:**

**0.25 mm (0.0098 in)**

- If not within allowable limit, replace oil pump cover assembly.

GI

MA

EM

LC

EC

FE

CL

MT

AT

FA

RA

BR

ST

RS

BT

HA

EL

IDX

## REPAIR FOR COMPONENT PARTS

### Oil Pump (Cont'd)

#### ASSEMBLY

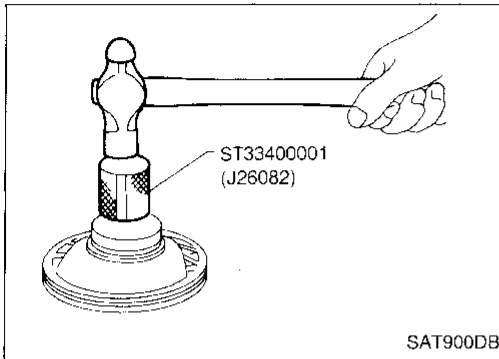

1. Install oil seal on oil pump housing.

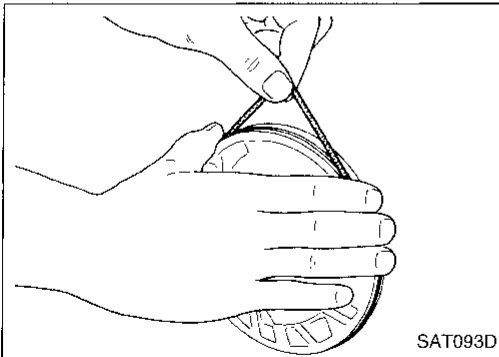

2. Install O-ring on oil pump housing.
  - **Apply ATF to O-ring.**

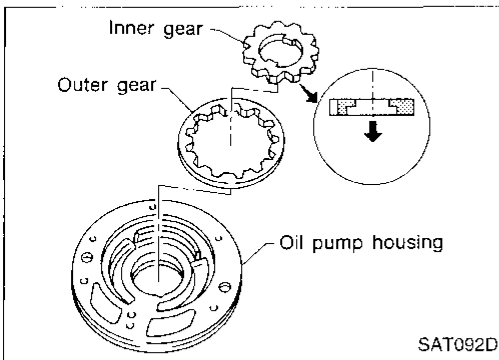

3. Install inner and outer gears on oil pump housing.
  - **Be careful of direction of inner gear.**

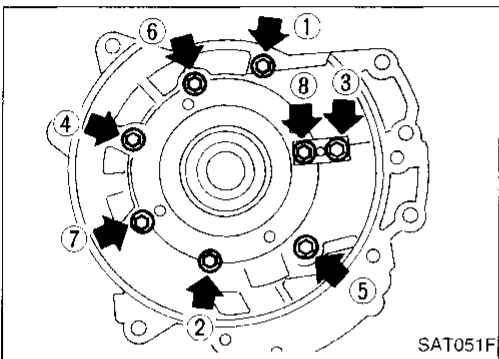

4. Install oil pump cover on oil pump housing.
  - a. Wrap masking tape around splines of oil pump cover assembly to protect seal. Position oil pump cover assembly on oil pump housing assembly, then remove masking tape.
  - b. Tighten bolts in a crisscross pattern.

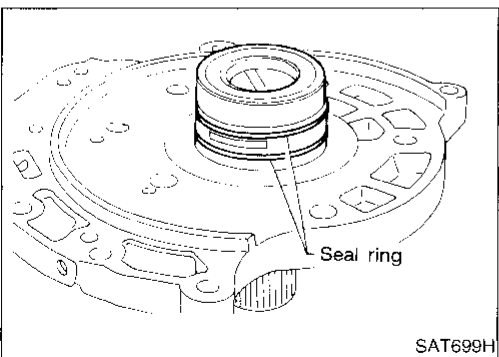

5. Install new seal rings carefully after packing ring groove with petroleum jelly.
  - **Do not spread gap of seal ring excessively while installing. The ring may be deformed.**



Control Valve Assembly

SEC. 317

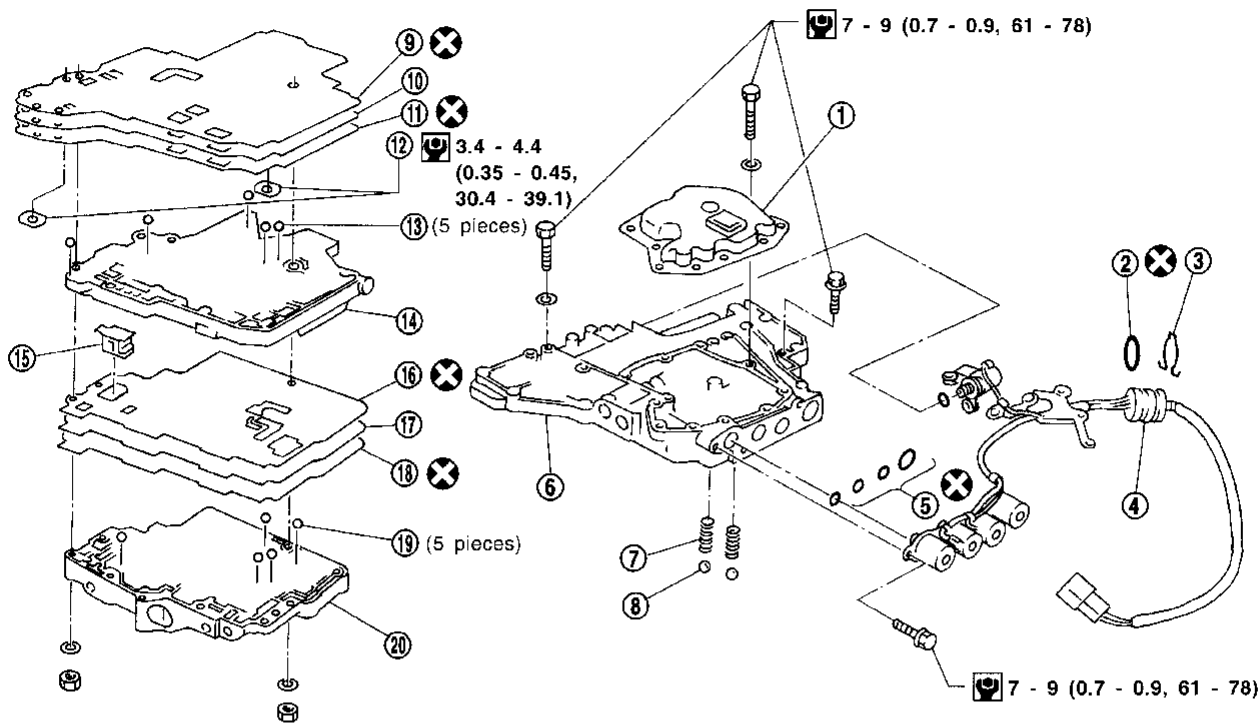

- |                                  |                                 |                                 |
|----------------------------------|---------------------------------|---------------------------------|
| ① Oil strainer                   | ⑧ Check ball                    | ⑮ Pilot filter                  |
| ② O-ring                         | ⑨ Lower separating gasket       | ⑯ Upper inter separating gasket |
| ③ Clamp                          | ⑩ Separating plate              | ⑰ Separating plate              |
| ④ Terminal body                  | ⑪ Lower inter separating gasket | ⑱ Upper separating gasket       |
| ⑤ O-rings                        | ⑫ Support plate                 | ⑲ Steel ball                    |
| ⑥ Control valve lower body       | ⑬ Steel ball                    | ⑳ Control valve upper body      |
| ⑦ Oil cooler relief valve spring | ⑭ Control valve inter body      |                                 |

**DISASSEMBLY**

Disassemble upper, inter and lower bodies.

**Bolt length, number and location:**

Bolt symbol	a	b	c	d	e	f
Bolt length "ℓ" mm (in)	13.5	58.0	40.0	66.0	33.0	78.0
 ℓ	(0.531)	(2.283)	(1.575)	(2.598)	(1.299)	(3.071)
Number of bolts	6	3	6	11	2	2

f: Reamer bolt and nut.

GI

MA

EM

LC

EC

FE

CL

MT

AT

FA

RA

BR

ST

RS

BT

HA

EL

IDX

# REPAIR FOR COMPONENT PARTS

## Control Valve Assembly (Cont'd)

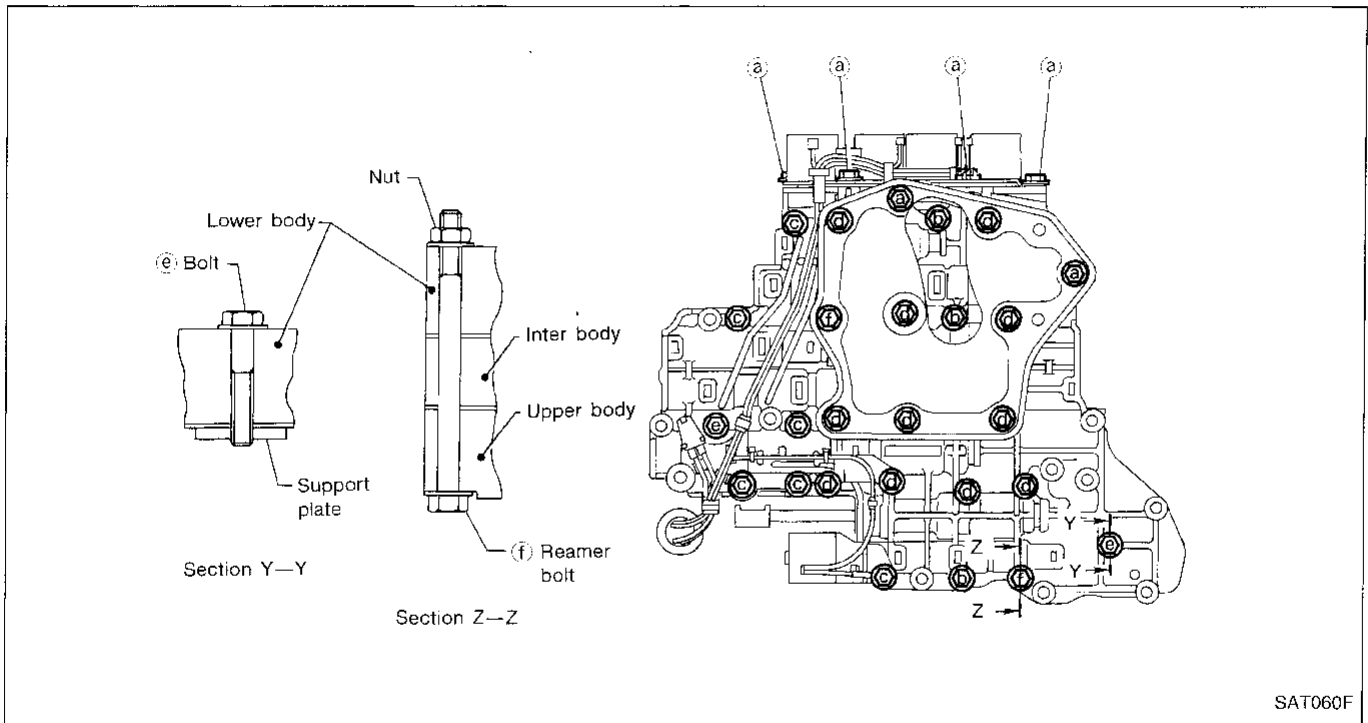

SAT060F

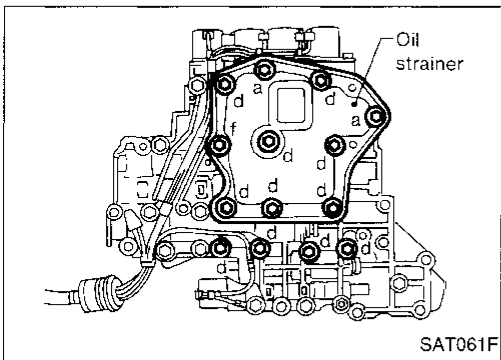

- a. Remove bolts (a), (d) and nut (f) and remove oil strainer from control valve assembly.

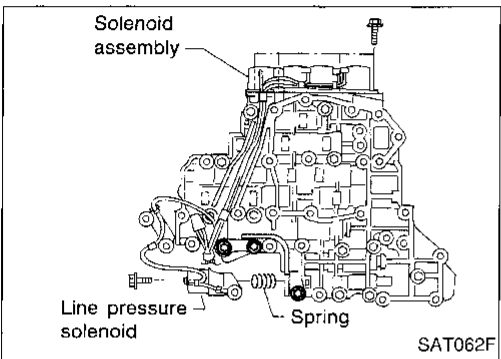

- b. Remove solenoid valve assembly and line pressure solenoid valve from control valve assembly.

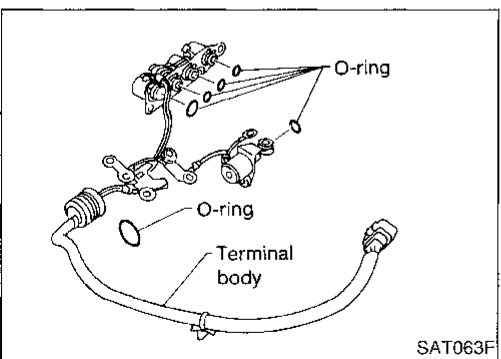

- c. Remove O-rings from solenoid valves and terminal body.

## REPAIR FOR COMPONENT PARTS

### Control Valve Assembly (Cont'd)

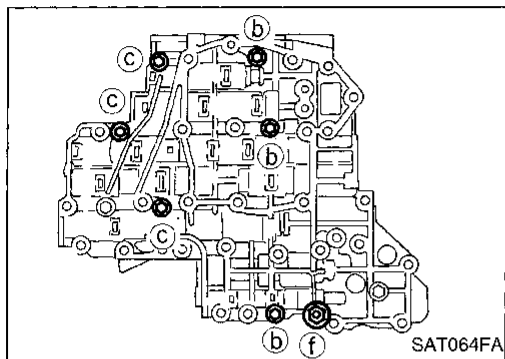

- d. Place upper body facedown, and remove bolts (b), (c) and nut (f).

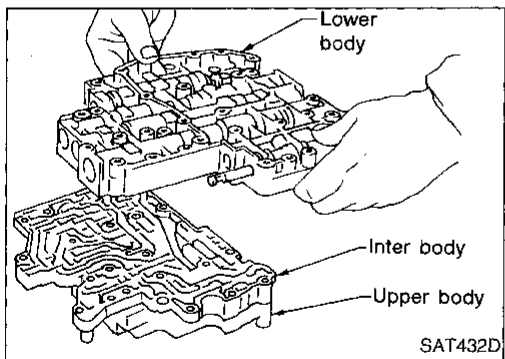

- e. Remove inter body from lower body.

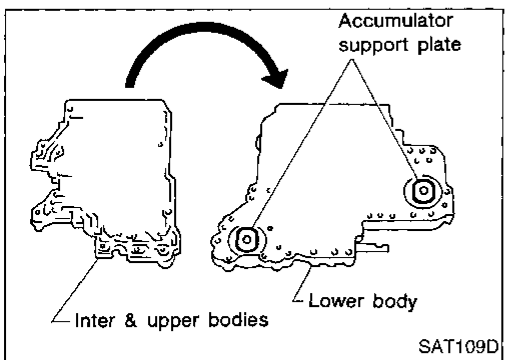

- f. Turn over lower body, and remove accumulator support plate.

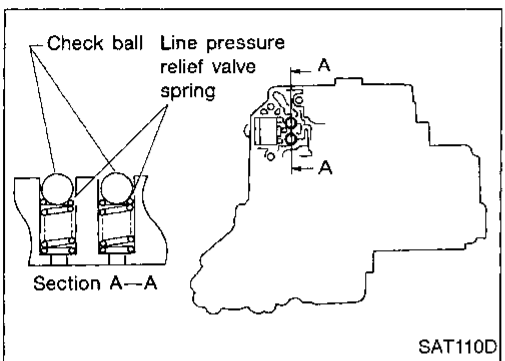

- g. Remove bolts (e), separating plate and separating gasket from lower body.

- h. Remove steel balls and relief valve springs from lower body.

- **Be careful not to lose steel balls and relief valve springs.**

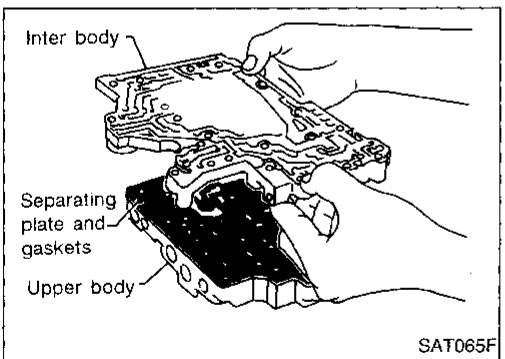

- i. Remove inter body from upper body.

GI

MA

EM

LC

EC

FE

CL

MT

AT

FA

RA

BR

ST

RS

BT

HA

EL

IDX

## REPAIR FOR COMPONENT PARTS

### Control Valve Assembly (Cont'd)

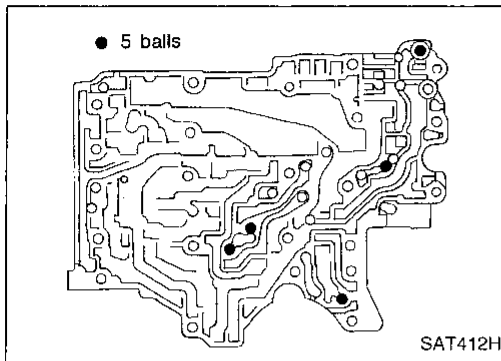

- j. Check to see that steel balls are properly positioned in inter body and then remove them.
- **Be careful not to lose steel balls.**

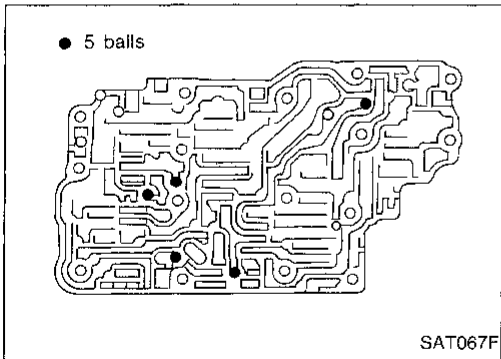

- k. Check to see that steel balls are properly positioned in upper body and then remove them.
- **Be careful not to lose steel balls.**

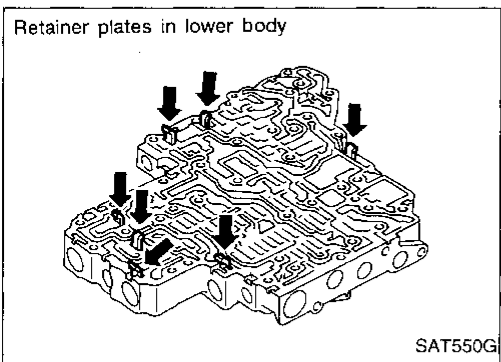

### INSPECTION

#### Lower and upper bodies

- Check to see that retainer plates are properly positioned in lower body.

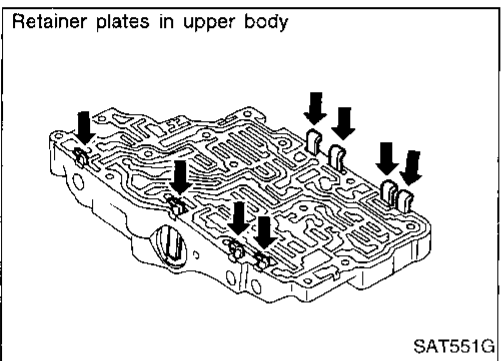

- Check to see that retainer plates are properly positioned in upper body.
- **Be careful not to lose these parts.**

#### Oil strainer

- Check wire netting of oil strainer for damage.

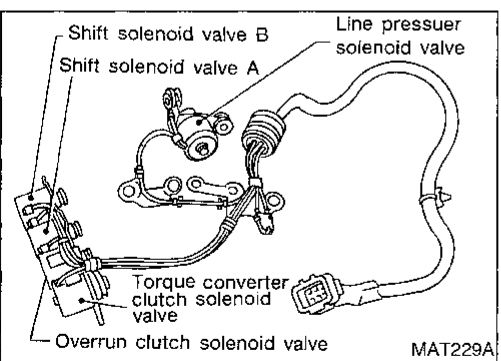

#### Shift solenoid valves A and B, line pressure solenoid valve, torque converter clutch solenoid valve and overrun clutch solenoid valve.

- Measure resistance. Refer to "Electrical Components Inspection". AT-106

# REPAIR FOR COMPONENT PARTS

## Control Valve Assembly (Cont'd)

### Oil cooler relief valve spring.

- Check springs for damage or deformation.
- Measure free length and outer diameter

#### Inspection standard:

Unit: mm (in)

Part No.	ℓ	D
31872-31X00	17.02 (0.6701)	8.0 (0.315)

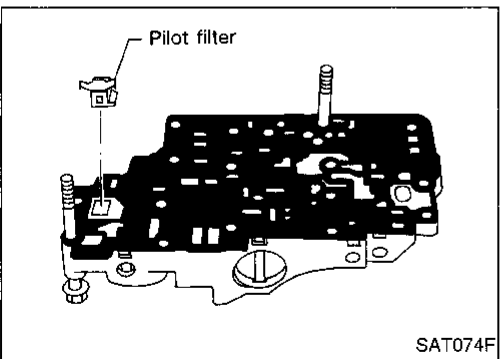
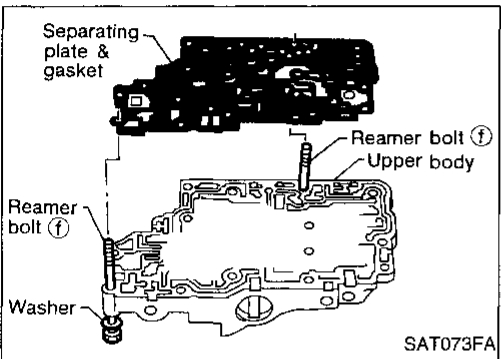
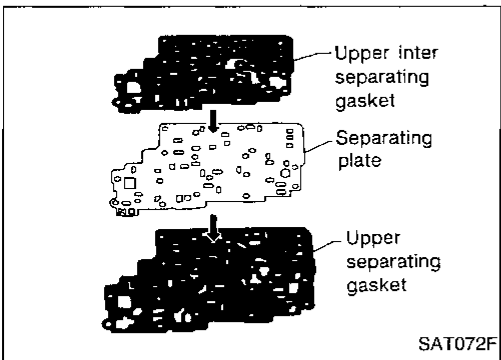
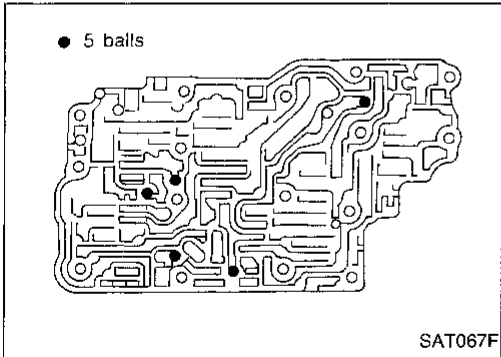
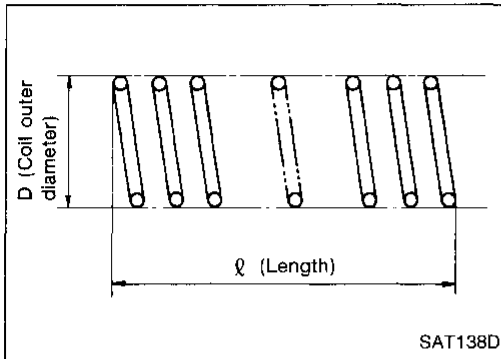

### ASSEMBLY

1. Install upper, inter and lower body.
  - a. Place oil circuit of upper body face up. Install steel balls in their proper positions.
  - b. Install upper separating gasket, upper inter separating gasket and upper separating plate in order shown in illustration.
  - c. Install reamer bolts ① from bottom of upper body. Using reamer bolts as guides, install separating plate and gaskets as a set.
  - d. Install pilot filter.

GI

MA

EM

LC

EC

FE

CL

MT

AT

FA

RA

BR

ST

RS

BT

HA

EL

IDX

## REPAIR FOR COMPONENT PARTS

### Control Valve Assembly (Cont'd)

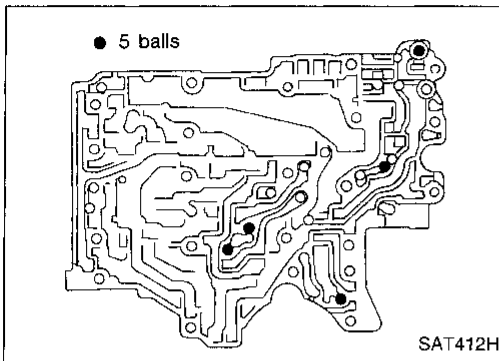

- e. Place lower body as shown in illustration (side of inter body face up). Install steel balls in their proper positions.

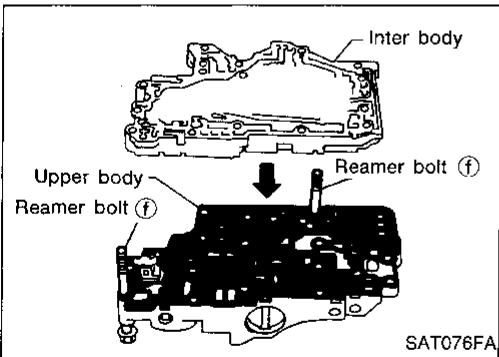

- f. Install inter body on upper body using reamer bolts (f) as guides.

- Be careful not to dislocate or drop steel balls.

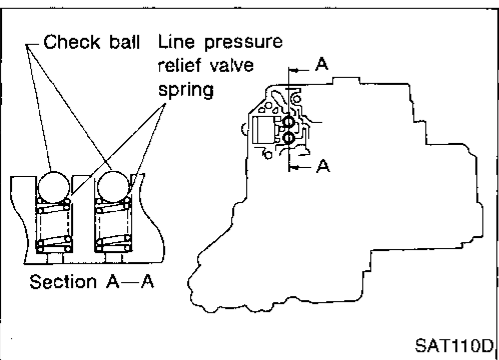

- g. Install steel balls and relief valve springs in their proper positions in lower body.

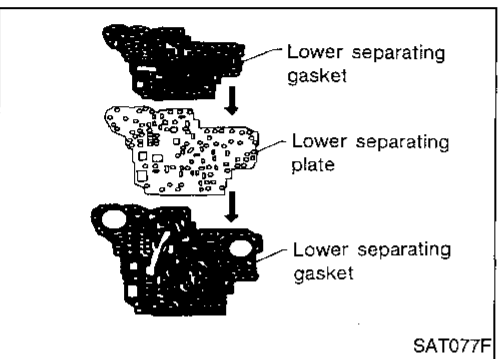

- h. Install lower separating gasket, inter separating gasket and lower separating plate in order shown in illustration.

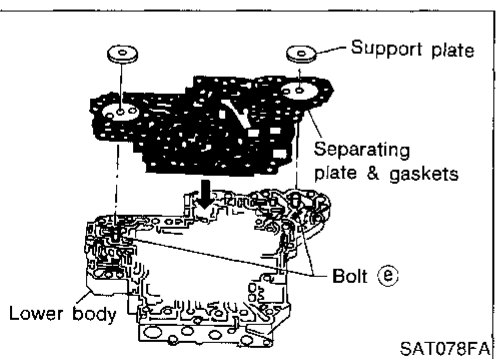

- i. Install bolts (e) from bottom of lower body. Using bolt (e) as guides, install separating plate and gaskets as a set.
- j. Temporarily install support plates on lower body.

# REPAIR FOR COMPONENT PARTS

## Control Valve Assembly (Cont'd)

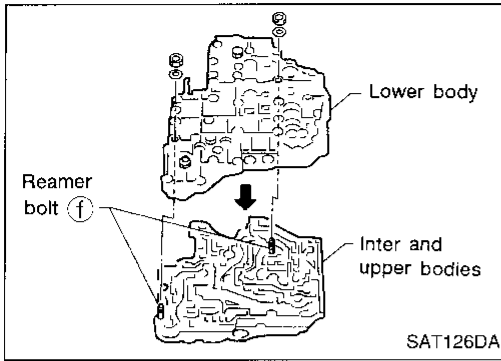

k. Install lower body on inter body using reamer bolts (f) as guides and tighten reamer bolts (f) slightly.

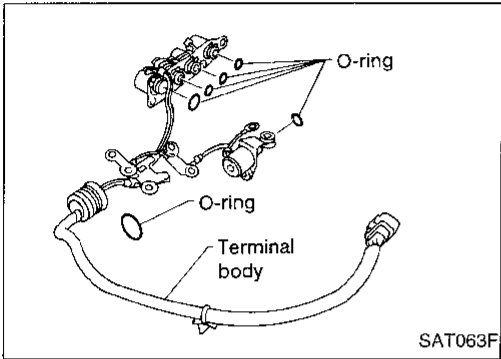

2. Install O-rings to solenoid valves and terminal body.  
 • **Apply ATF to O-rings.**

3. Install and tighten bolts.

**Bolt length, number and location:**

Bolt symbol	a	b	c	d	e	f
Bolt length "l"						
 mm (in)	13.5 (0.531)	58.0 (2.283)	40.0 (1.575)	66.0 (2.598)	33.0 (1.299)	78.0 (3.071)
Number of bolts	6	3	6	11	2	2

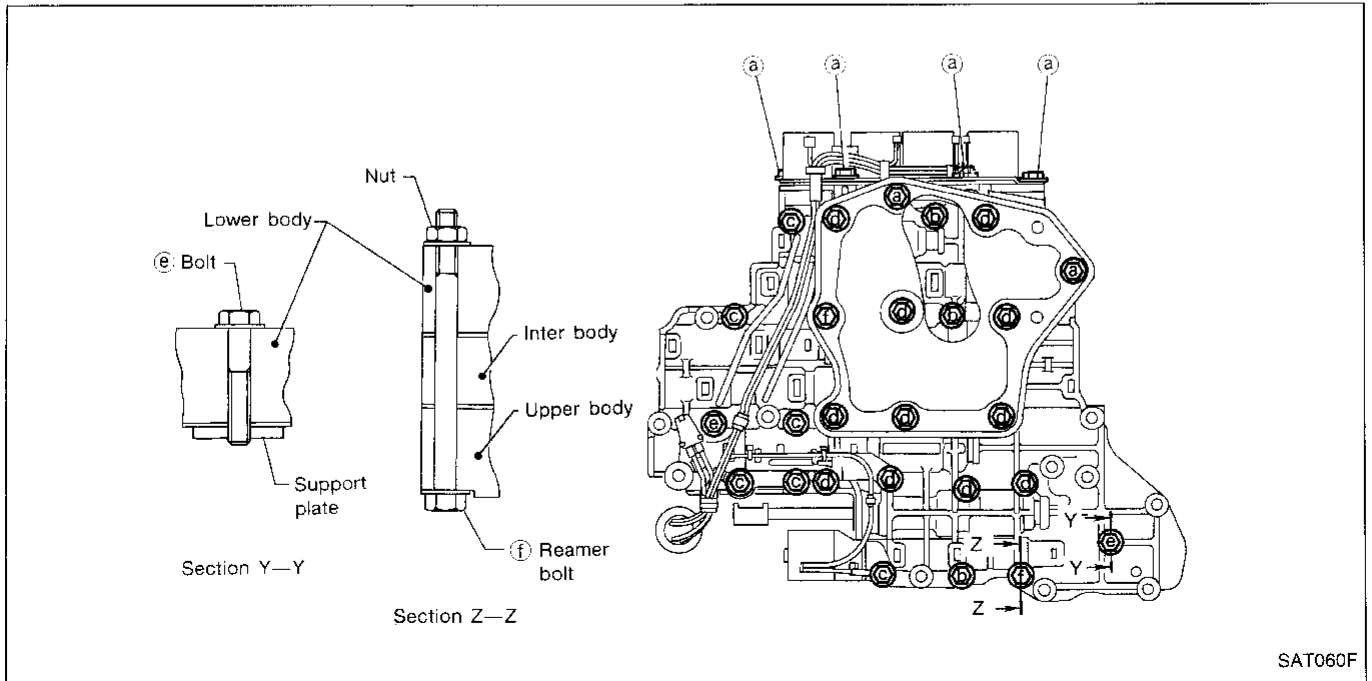

GI

MA

EM

LC

EC

FE

CL

MT

AT

FA

RA

BR

ST

RS

BT

HA

EL

IDX

## REPAIR FOR COMPONENT PARTS

### Control Valve Assembly (Cont'd)

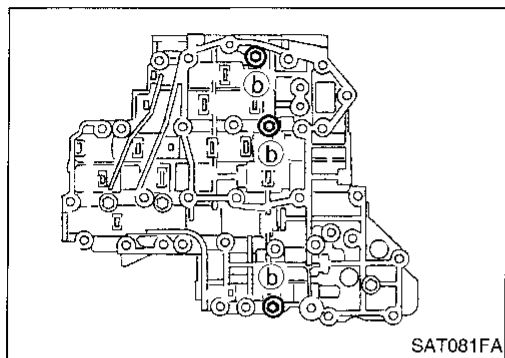

- a. Install and tighten bolts **(b)** to specified torque.  
☛ : 7 - 9 N·m (0.7 - 0.9 kg·m, 61 - 78 in·lb)

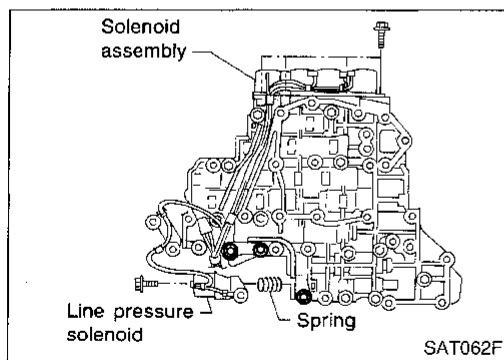

- b. Install solenoid valve assembly and line pressure solenoid valve to lower body.

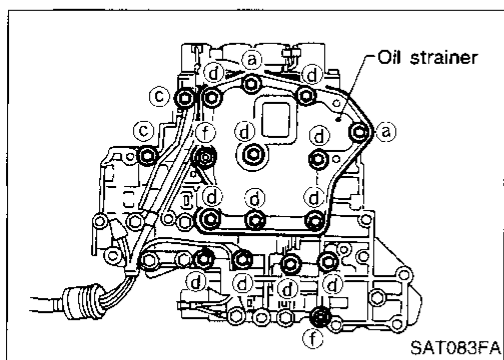

- c. Set oil strainer, then tighten bolts **(a)**, **(c)**, **(d)** and nuts **(f)** to specified torque.  
☛ : 7 - 9 N·m (0.7 - 0.9 kg·m, 61 - 78 in·lb)

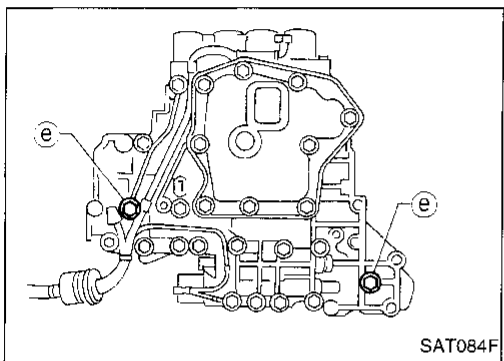

- d. Tighten bolts **(e)** to specified torque.  
☛ : 3.4 - 4.4 N·m (0.35 - 0.45 kg·m, 30.4 - 39.1 in·lb)



Control Valve Upper Body

SEC. 317

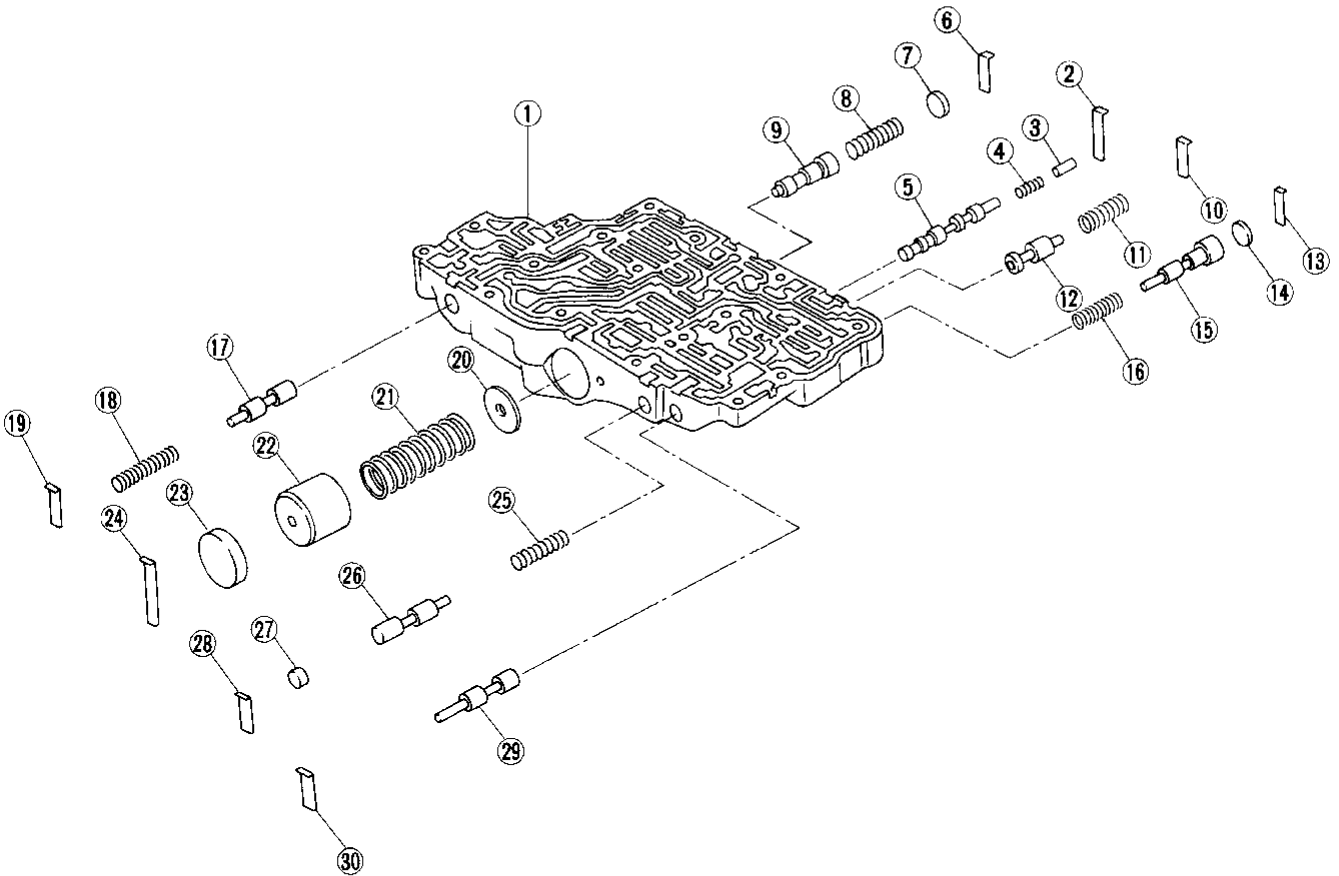

GI  
MA  
EM  
LC  
EC  
FE  
CL  
MT  
**AT**  
FA  
RA  
BR  
ST  
RS  
BT

SAT859H

Apply ATF to all components before installation.

- |                         |                                 |                                  |
|-------------------------|---------------------------------|----------------------------------|
| ① Upper body            | ⑪ Return spring                 | ⑳ 1-2 accumulator retainer plate |
| ② Retainer plate        | ⑫ Torque converter relief valve | ㉑ Return spring                  |
| ③ Plug                  | ⑬ Retainer plate                | ㉒ 1-2 accumulator piston         |
| ④ Return spring         | ⑭ Plug                          | ㉓ Plug                           |
| ⑤ Lock-up control valve | ⑮ Overrun clutch reducing valve | ㉔ Retainer plate                 |
| ⑥ Retainer plate        | ⑯ Return spring                 | ㉕ Return spring                  |
| ⑦ Plug                  | ⑰ Pilot valve                   | ㉖ 1st reducing valve             |
| ⑧ Return spring         | ⑱ Return spring                 | ㉗ Plug                           |
| ⑨ 1-2 accumulator valve | ㉑ Retainer plate                | ㉘ Retainer plate                 |
| ⑩ Retainer plate        | ㉒ 2-3 timing valve              | ㉙ Retainer plate                 |

## REPAIR FOR COMPONENT PARTS

### Control Valve Upper Body (Cont'd)

#### DISASSEMBLY

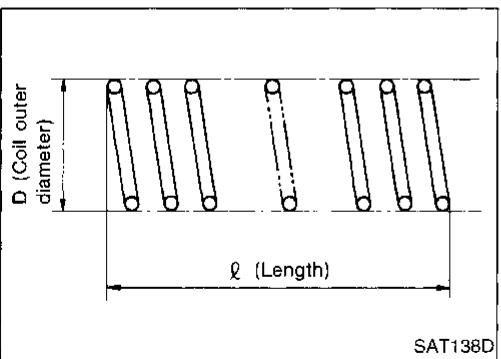
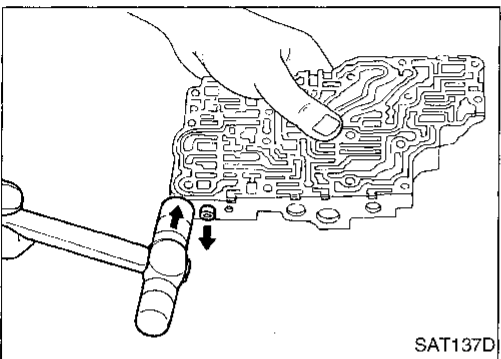
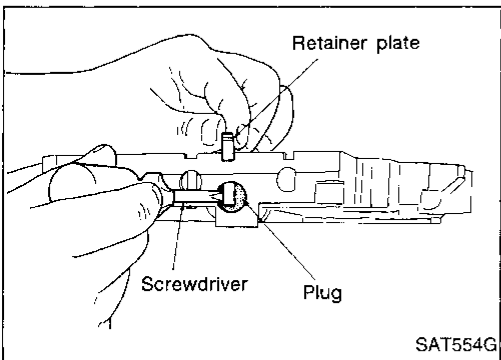
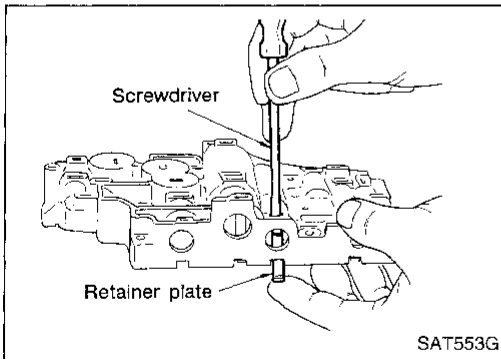
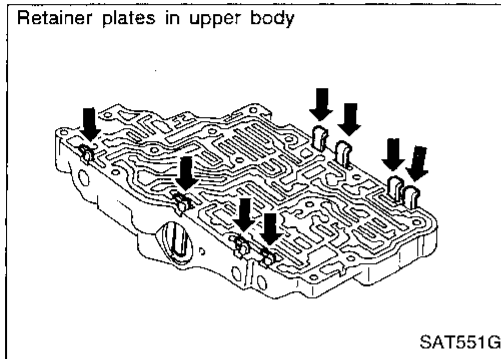

1. Remove valves at retainer plates.
  - Do not use a magnetic "hand".

a. Use a screwdriver to remove retainer plates.

b. Remove retainer plates while holding spring, plugs or sleeves.

- Remove plugs slowly to prevent internal parts from jumping out.

c. Place mating surface of valve body face down, and remove internal parts.

- If a valve is hard to remove, place valve body face down and lightly tap it with a soft hammer.
- Be careful not to drop or damage valves and sleeves.

#### INSPECTION

##### Valve spring

- Measure free length and outer diameter of each valve spring. Also check for damage or deformation.

##### Inspection standard:

Refer to SDS, AT-225.

- Replace valve springs if deformed or fatigued.

##### Control valves

- Check sliding surfaces of valves, sleeves and plugs.

# REPAIR FOR COMPONENT PARTS

## Control Valve Upper Body (Cont'd)

### ASSEMBLY

- Lay control valve body down when installing valves. Do not stand the control valve body upright.

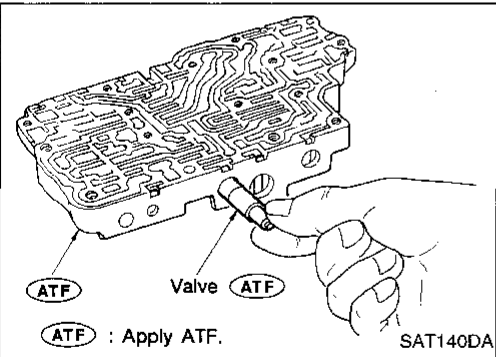
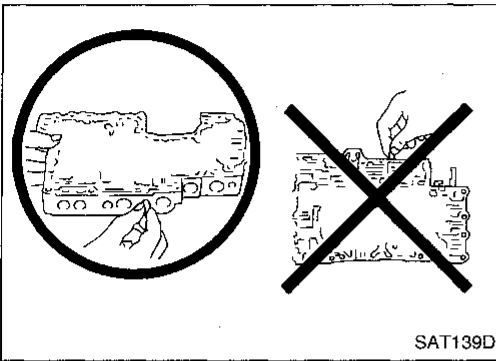

1. Lubricate the control valve body and all valves with ATF. Install control valves by sliding them carefully into their bores.
- Be careful not to scratch or damage valve body.

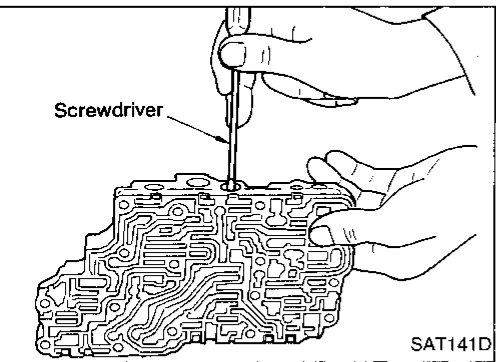

- Wrap a small screwdriver with vinyl tape and use it to insert the valves into their proper positions.

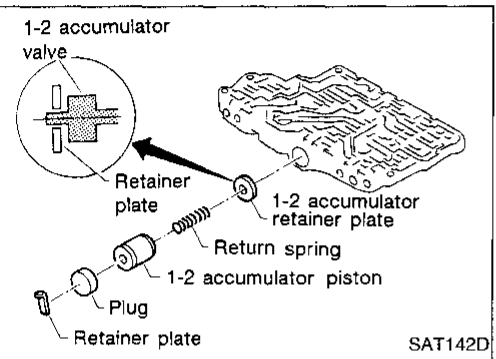

### 1-2 accumulator valve

- Install 1-2 accumulator valve. Align 1-2 accumulator retainer plate from opposite side of control valve body.
- Install return spring, 1-2 accumulator piston and plug.

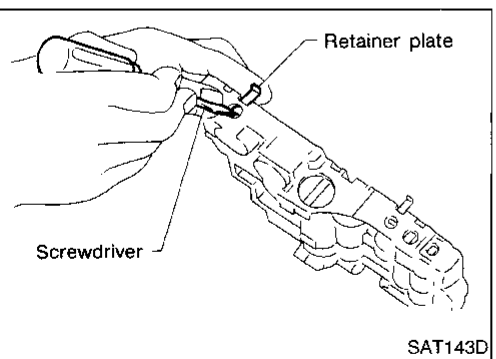

2. Install retainer plates
- While pushing plug or return spring, install retainer plate.

GI  
MA  
EM  
LC  
EC  
FE  
CL  
MT  
AT  
FA  
RA  
BR  
ST  
RS  
BT  
HA  
EL  
IDX

# REPAIR FOR COMPONENT PARTS

## Control Valve Upper Body (Cont'd)

### Retainer plate

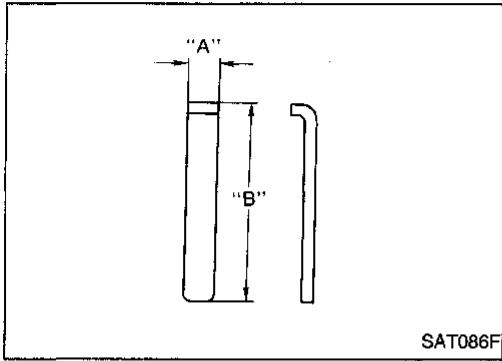

Unit: mm (in)

Name of control valve	Length A	Length B
Pilot valve	6.0 (0.236)	21.5 (0.846)
1-2 accumulator valve		38.5 (1.516)
1-2 accumulator piston valve		21.5 (0.846)
1st reducing valve		24.0 (0.945)
Overrun clutch reducing valve		21.5 (0.846)
Torque converter relief valve		28.0 (1.102)
Lock-up control valve		

- Install proper retainer plates.

Control Valve Lower Body

SEC. 317

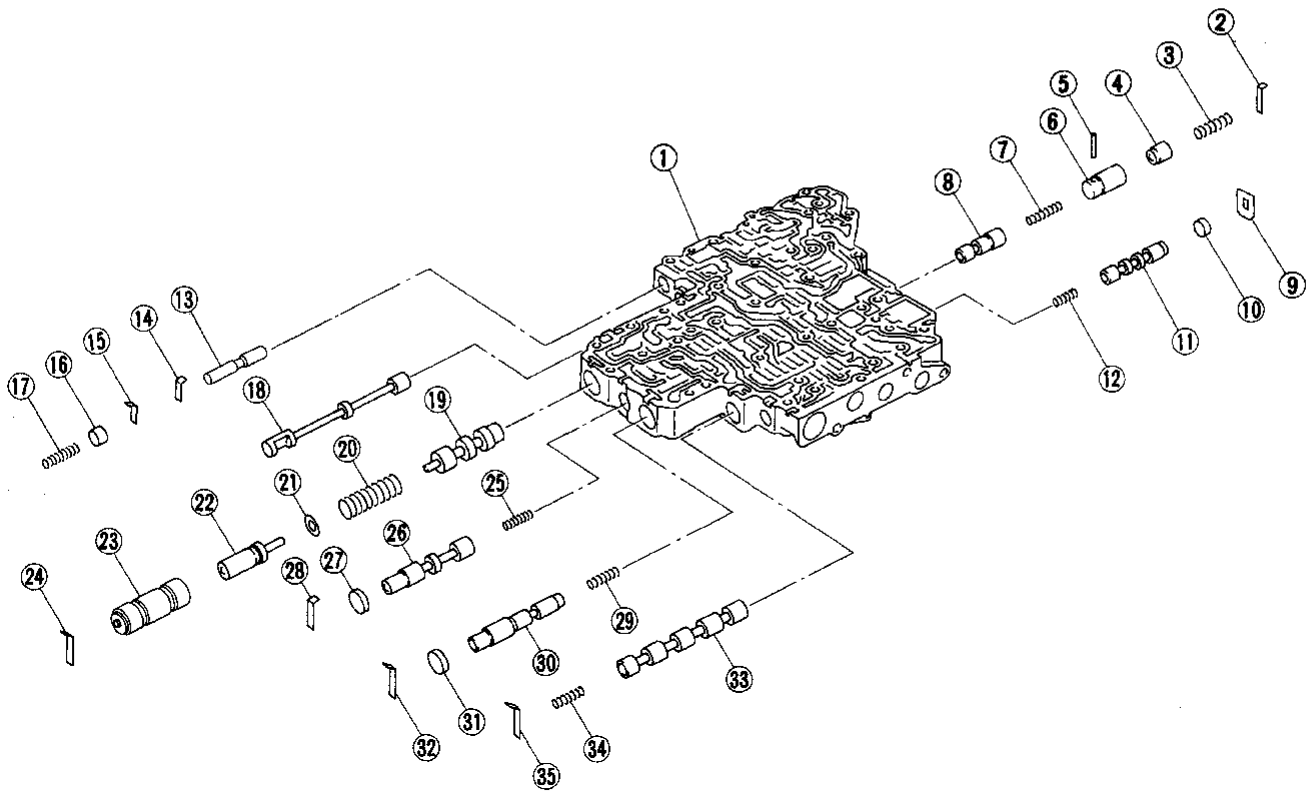

GI  
MA  
EM  
LC  
EC  
FE  
CL  
MT  
AT  
FA  
RA  
BR  
ST  
RS

SAT414H BT

Apply ATF to all components before installation.

- |                           |                            |                                |
|---------------------------|----------------------------|--------------------------------|
| ① Lower body              | ⑬ Plug                     | ⑳ Retainer plate               |
| ② Retainer plate          | ⑭ Retaining plate          | ㉑ Return spring                |
| ③ Return spring           | ⑮ Retaining plate          | ㉒ Overrun clutch control valve |
| ④ Piston                  | ⑯ Plug                     | ㉓ Plug                         |
| ⑤ Parallel pin            | ⑰ Return spring            | ㉔ Retainer plate               |
| ⑥ Sleeve                  | ⑱ Manual valve             | ㉕ Return spring                |
| ⑦ Return spring           | ⑲ Pressure regulator valve | ㉖ Accumulator control valve    |
| ⑧ Pressure modifier valve | ㉑ Return spring            | ㉗ Plug                         |
| ⑨ Retainer plate          | ㉒ Spring seat              | ㉘ Retainer plate               |
| ⑩ Plug                    | ㉓ Plug                     | ㉙ Shift valve A                |
| ⑪ Shift valve B           | ㉔ Sleeve                   | ㉚ Retainer spring              |
| ⑫ Return spring           |                            | ㉛ Retainer plate               |

HA  
EL  
IDX

# REPAIR FOR COMPONENT PARTS

## Control Valve Lower Body (Cont'd)

### DISASSEMBLY

Remove valves at retainer plate.

For removal procedures, refer to "DISASSEMBLY" of Control Valve Upper Body. AT-162

Retainer plates in lower body

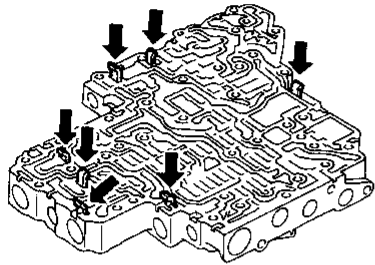

SAT550G

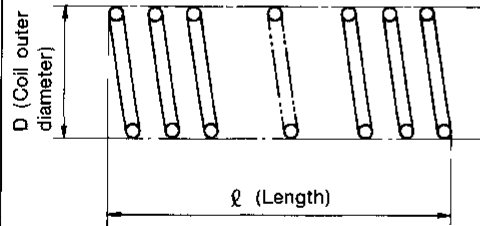

SAT138D

### INSPECTION

#### Valve springs

- Check each valve spring for damage or deformation. Also measure free length and outer diameter.

**Inspection standard:**

**Refer to SDS, AT-225.**

- Replace valve springs if deformed or fatigued.

#### Control valves

- Check sliding surfaces of control valves, sleeves and plugs for damage.

Retainer plates in lower body

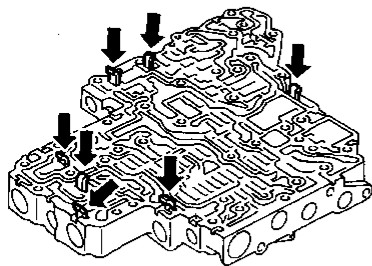

SAT550A

### ASSEMBLY

- Install control valves.

For installation procedures, refer to "ASSEMBLY" of Control Valve Upper Body. AT-163

### Retainer plate

Unit: mm (in)

Name of control valve and plug	Length A	Length B	Type
Plug	6.0 (0.236)	19.5 (0.768)	I
Pressure regulator valve		28.0 (1.102)	
Accumulator control valve			
Shift valve A			
Overrun clutch control valve			
Pressure modifier valve	—	—	II
Shift valve B			

- Install proper retainer plates.

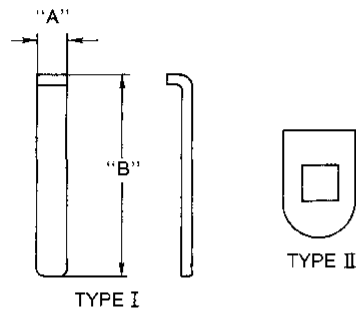

SAT089F

Reverse Clutch

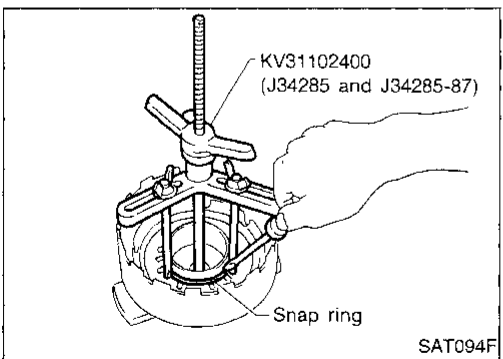
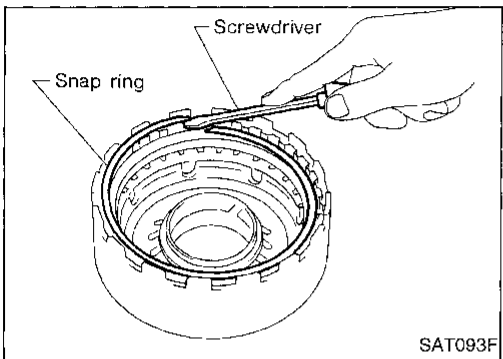
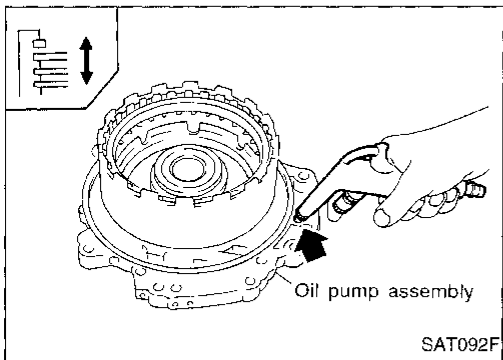
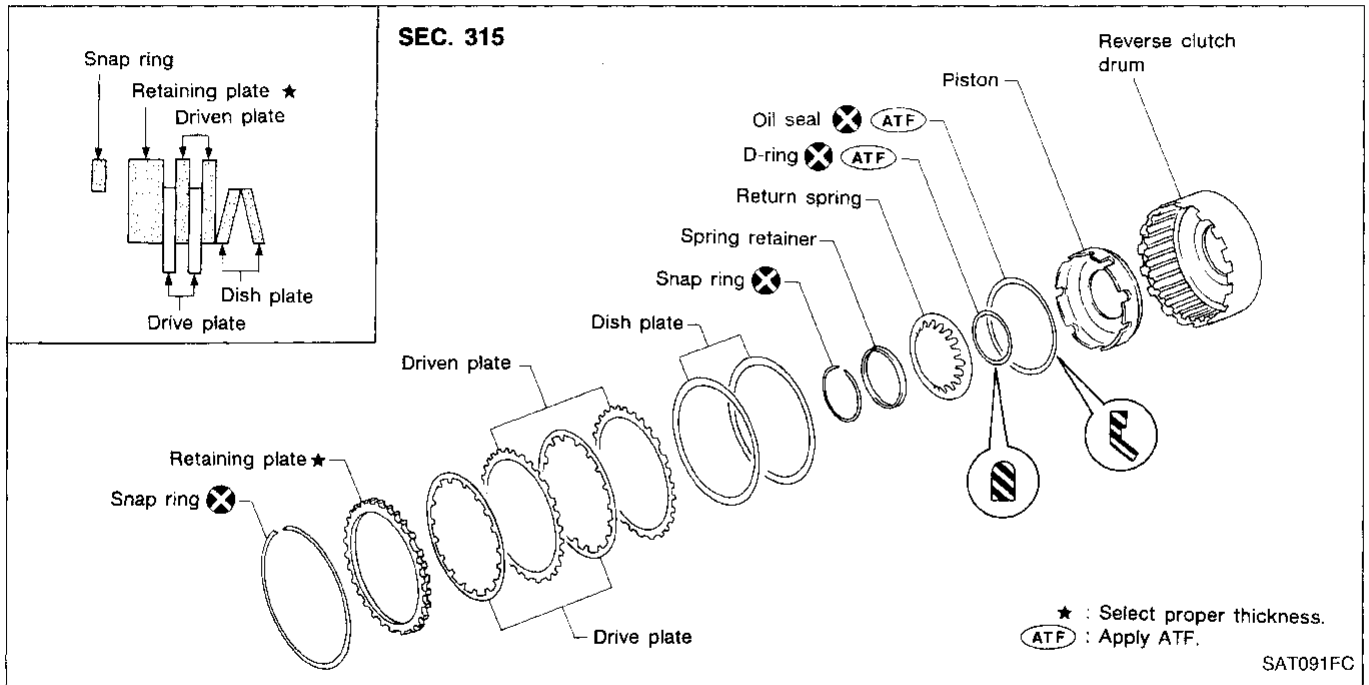

**DISASSEMBLY**

1. Check operation of reverse clutch
  - a. Install seal ring onto drum support of oil pump cover and install reverse clutch assembly. Apply compressed air to oil hole.
  - b. Check to see that retaining plate moves to snap ring.
  - c. If retaining plate does not contact snap ring:
    - D-ring might be damaged.
    - Oil seal might be damaged.
    - Fluid might be leaking past piston check ball.
2. Remove snap ring.
3. Remove drive plates, driven plates, retaining plate, and dish plates.
4. Set Tool on spring retainer and remove snap ring from reverse clutch drum while compressing return springs.
  - **Set Tool directly over springs.**
  - **Do not expand snap ring excessively.**
5. Remove spring retainer and return springs.

GI  
 MA  
 EM  
 LC  
 EC  
 FE  
 CL

MT

AT

FA

RA

BR

ST

RS

BT

HA

EL

IDX

## REPAIR FOR COMPONENT PARTS

### Reverse Clutch (Cont'd)

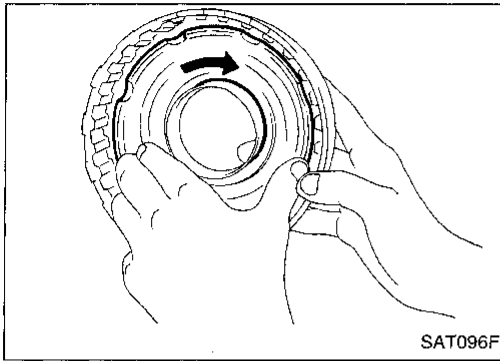

6. Remove piston from reverse clutch drum by turning it.
7. Remove D-ring and oil seal from piston.

### INSPECTION

#### Reverse clutch snap ring, spring retainer and return springs

- Check for deformation, fatigue or damage. If necessary, replace.

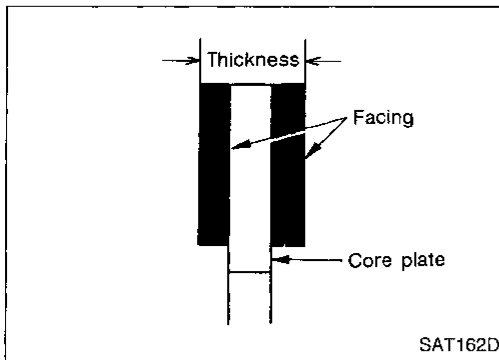

#### Reverse clutch drive plates

- Check facing for burns, cracks or damage.
- Measure thickness of facing.

##### Thickness of drive plate:

**Standard value: 1.6 mm (0.063 in)**

**Wear limit: 1.4 mm (0.055 in)**

- If not within wear limit, replace.

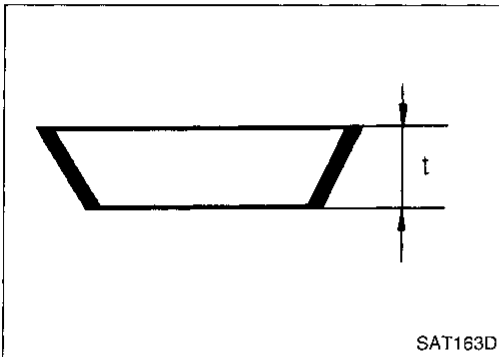

#### Reverse clutch dish plates

- Check for deformation or damage.
  - Measure thickness of dish plate.
- Thickness of dish plate: 3.08 mm (0.1213 in)**
- If deformed or fatigued, replace.

#### Reverse clutch piston

- Make sure that check balls are not fixed.
- Apply compressed air to check ball oil hole opposite the return spring. Make sure there is no air leakage.
- Apply compressed air to oil hole on return spring side to make sure that air leaks past ball.

### ASSEMBLY

1. Install D-ring and oil seal on piston.
- **Take care with the direction of lip seal.**
  - **Apply ATF to both parts.**

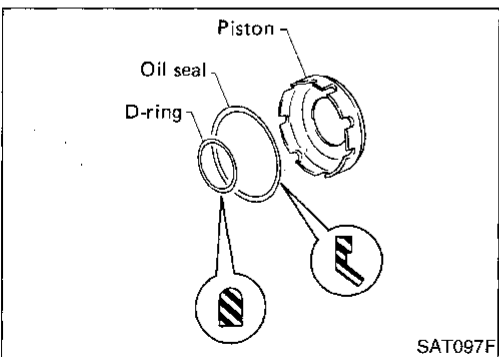



## REPAIR FOR COMPONENT PARTS

### Reverse Clutch (Cont'd)

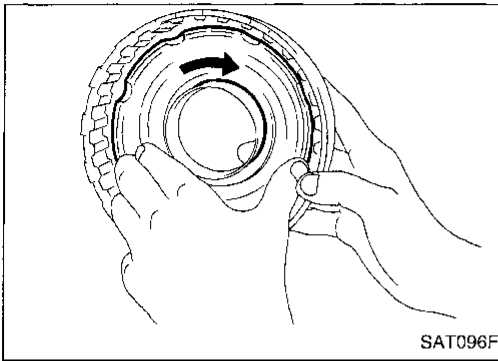

2. Install piston assembly by turning it slowly.
  - Apply ATF to inner surface of drum.

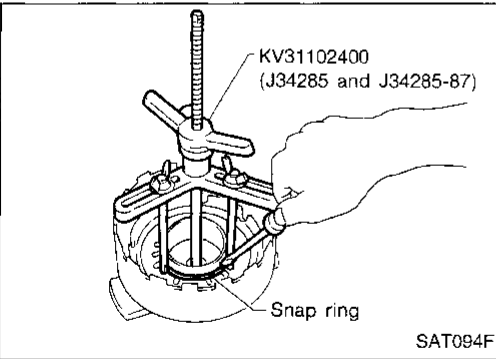

3. Install return springs and spring retainer on piston.
4. Set Tool on spring retainer and install snap ring while compressing return springs.
  - Set Tool directly over return springs.

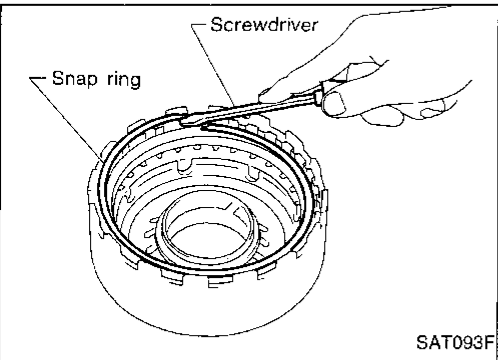

5. Install drive plates, driven plates, retaining plate and dish plates.
  - Take care with order of plates.
6. Install snap ring.

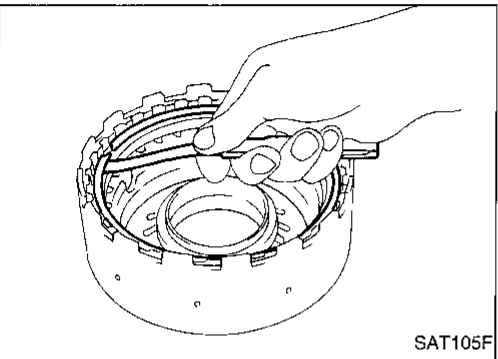

7. Measure clearance between retaining plate and snap ring. If not within allowable limit, select proper retaining plate.

**Specified clearance:**

**Standard 0.5 - 0.8 mm (0.020 - 0.031 in)**

**Allowable limit 1.2 mm (0.047 in)**

**Retaining plate:**

**Refer to SDS, AT-226.**

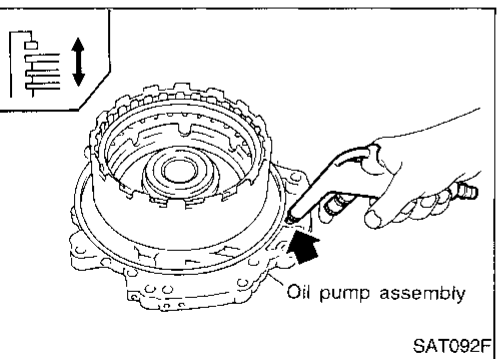

8. Check operation of reverse clutch.  
Refer to "DISASSEMBLY", "Reverse Clutch", AT-167.

GI

MA

EM

LC

EC

FE

CL

MT

AT

FA

RA

BR

ST

RS

BT

HA

EL

IDX

## High Clutch

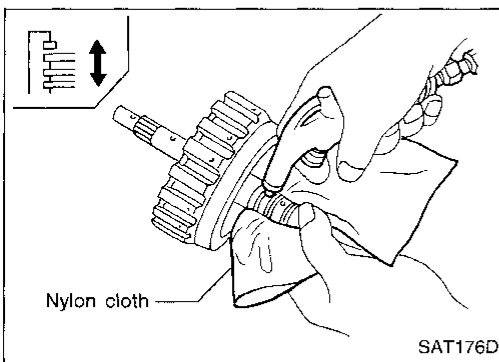
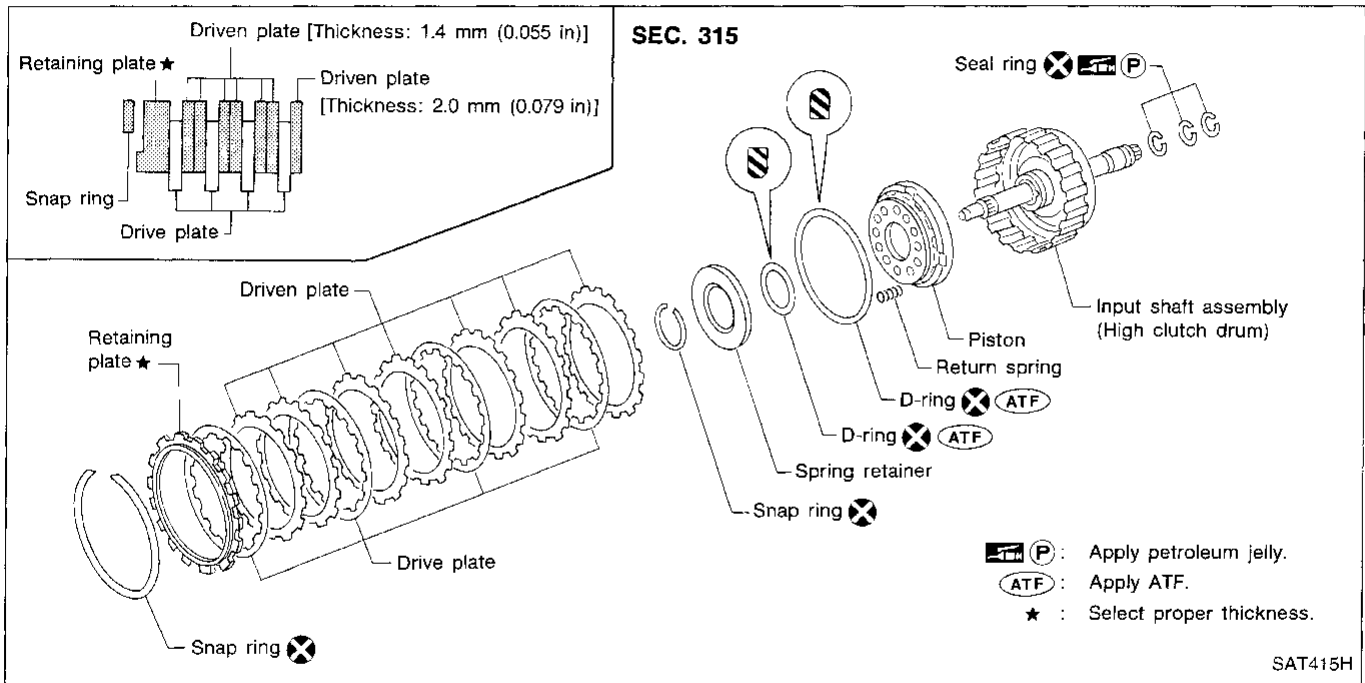

### DISASSEMBLY

1. Check operation of high clutch.
  - a. Apply compressed air to oil hole of input shaft with nylon cloth.
    - **Stop up hole on opposite side of input shaft with nylon cloth.**
  - b. Check to see that retaining plate moves to snap ring.
  - c. If retaining plate does not contact snap ring:
    - D-ring might be damaged.
    - Oil seal might be damaged.
    - Fluid might be leaking past piston check ball.

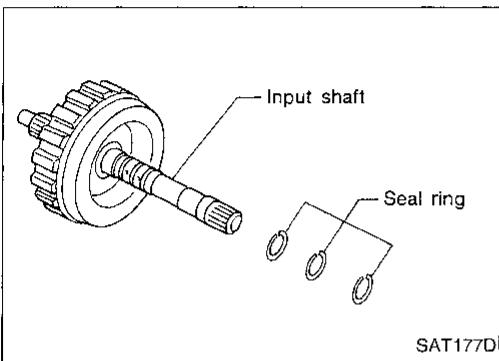

2. Remove seal rings from input shaft.
  - **Always replace when removed.**

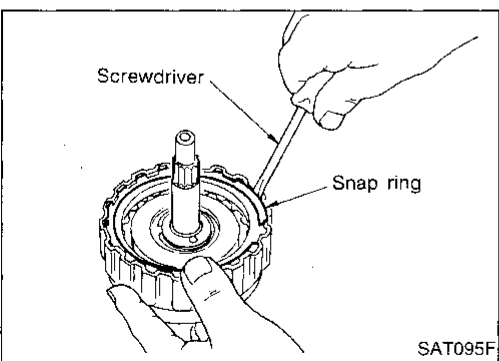

3. Remove snap ring.
4. Remove drive plates, driven plates and retaining plate.

## REPAIR FOR COMPONENT PARTS

### High Clutch (Cont'd)

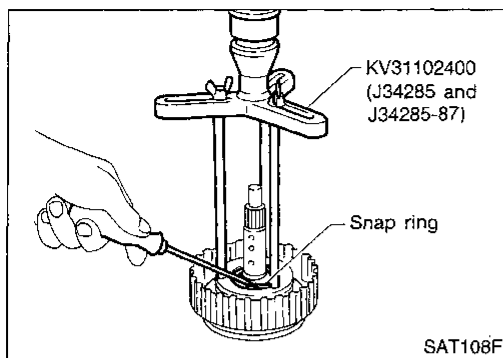

- Set Tool on spring retainer and remove snap ring from high clutch drum while compressing return springs.
  - **Set Tool directly over springs.**
  - **Do not expand snap ring excessively.**
- Remove spring retainer and return springs.

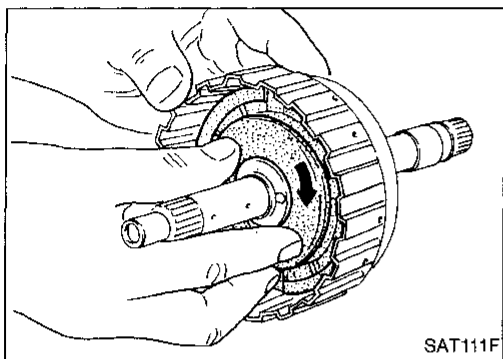

- Remove piston from high clutch drum by turning it.

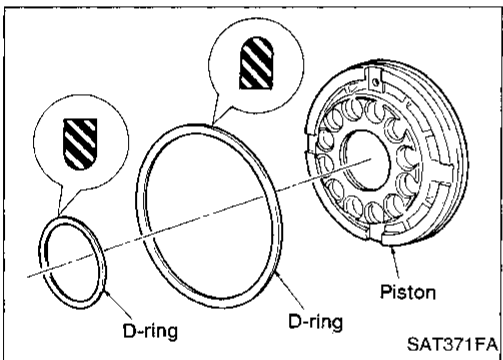

- Remove D-rings from piston.

### INSPECTION

#### High clutch snap ring, spring retainer and return springs.

- Check for deformation, fatigue or damage. If necessary, replace.
- **When replacing spring retainer and return springs, replace them as a set.**

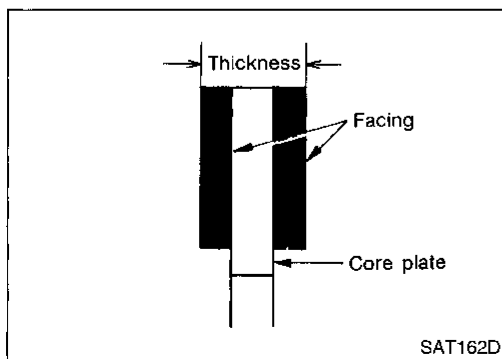

#### High clutch drive plates

- Check facing for burns, cracks or damage.
- Measure thickness of facing.
  - Thickness of drive plate:**
    - Standard value 1.6 mm (0.063 in)**
    - Wear limit 1.4 mm (0.055 in)**
- If not within wear limit, replace.

GI

MA

EM

LC

EC

FE

CL

MT

AT

FA

RA

BR

ST

RS

BT

HA

EL

IDX

## REPAIR FOR COMPONENT PARTS

### High Clutch (Cont'd)

#### High clutch piston

- Make sure that check balls are not fixed.
- Apply compressed air to check ball oil hole opposite the return spring. Make sure there is no air leakage.
- Apply compressed air to oil hole on return spring side to make sure that air leaks past ball.

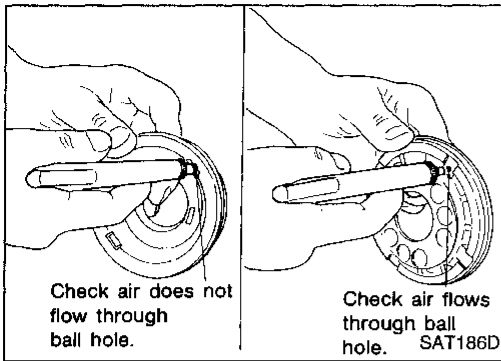

#### Seal ring clearance

- Install new seal rings onto input shaft.
- Measure clearance between seal ring and ring groove.  
**Standard clearance: 0.08 - 0.23 mm (0.0031 - 0.0091 in)**  
**Allowable limit: 0.23 mm (0.0091 in)**
- If not within allowable limit, replace input shaft assembly.

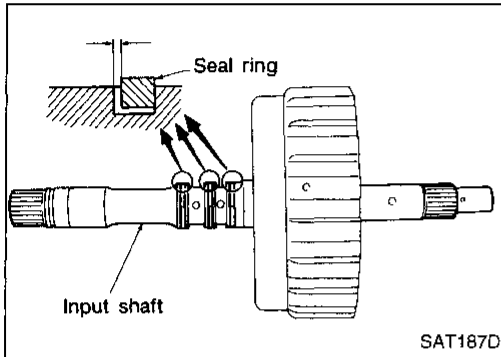

### ASSEMBLY

1. Install D-rings on piston.
  - Take care with the direction of oil seal.
  - Apply ATF to both parts.

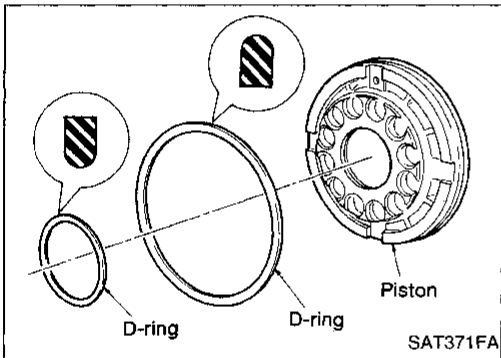

2. Install piston assembly by turning it slowly.
  - Apply ATF to inner surface of drum.

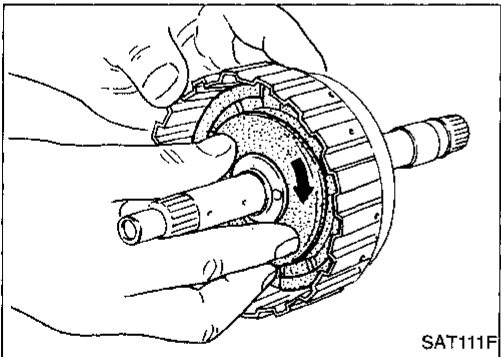

3. Install return springs and spring retainer on piston.

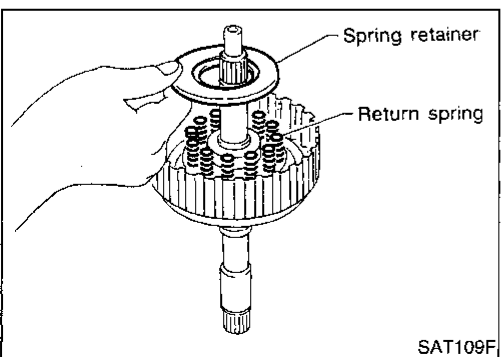

# REPAIR FOR COMPONENT PARTS

## High Clutch (Cont'd)

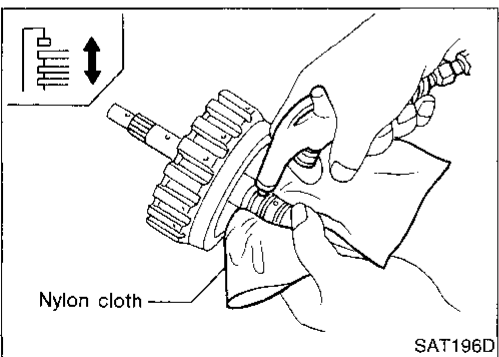
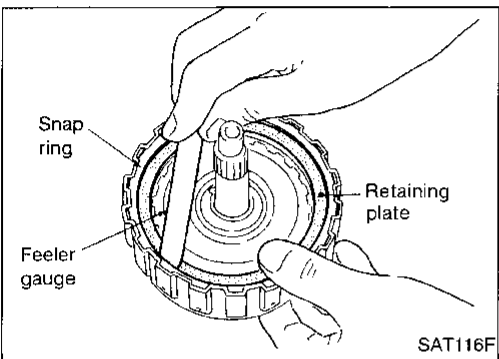
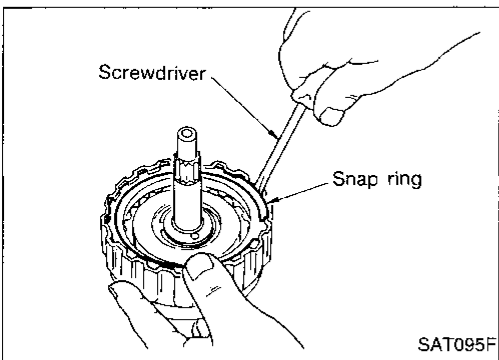
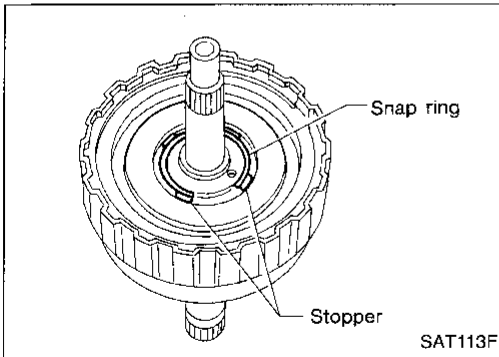
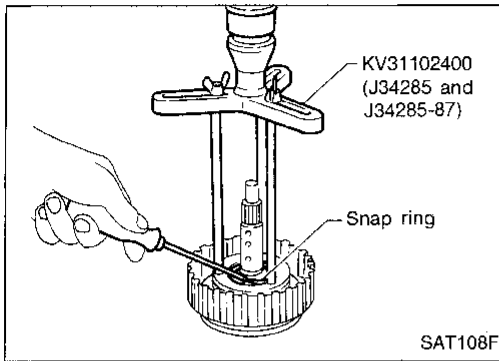

- Set Tool on spring retainer and install snap ring while compressing return springs.
- Set Tool directly over return springs.**

- Do not align snap ring gap with spring retainer stopper.**

- Install drive plates, driven plates and retaining plate.
- Take care with the order and direction of plates.**
- Install snap ring.

- Measure clearance between retaining plate and snap ring. If not within allowable limit, select proper retaining plate.

### Specified clearance:

Standard 1.8 - 2.2 mm (0.071 - 0.087 in)

Allowable limit 3.0 mm (0.118 in)

### Retaining plate:

Refer to SDS, AT-226.

- Check operation of high clutch.  
Refer to "DISASSEMBLY", "High Clutch", AT-170.

GI

MA

EM

LC

EC

FE

CL

MT

AT

FA

RA

BR

ST

RS

BT

HA

EL

IDX

# REPAIR FOR COMPONENT PARTS

## High Clutch (Cont'd)

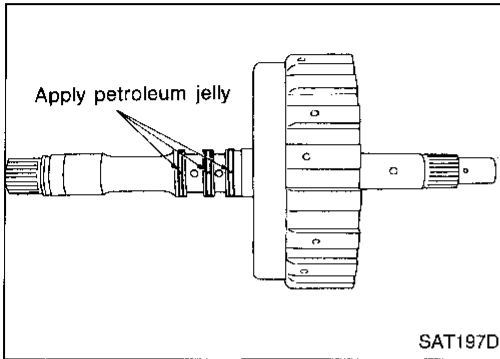

9. Install seal rings to input shaft.
  - Apply petroleum jelly to seal rings.
  - Always replace when removed.

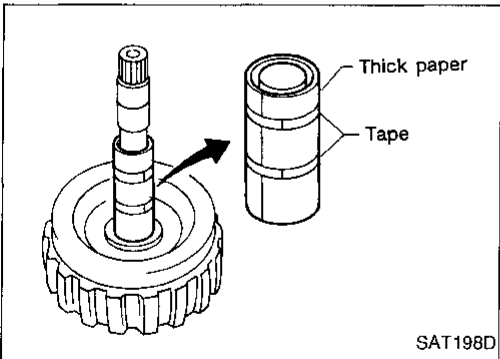

- Roll paper around seal rings to prevent seal rings from spreading.

## Forward Clutch and Overrun Clutch

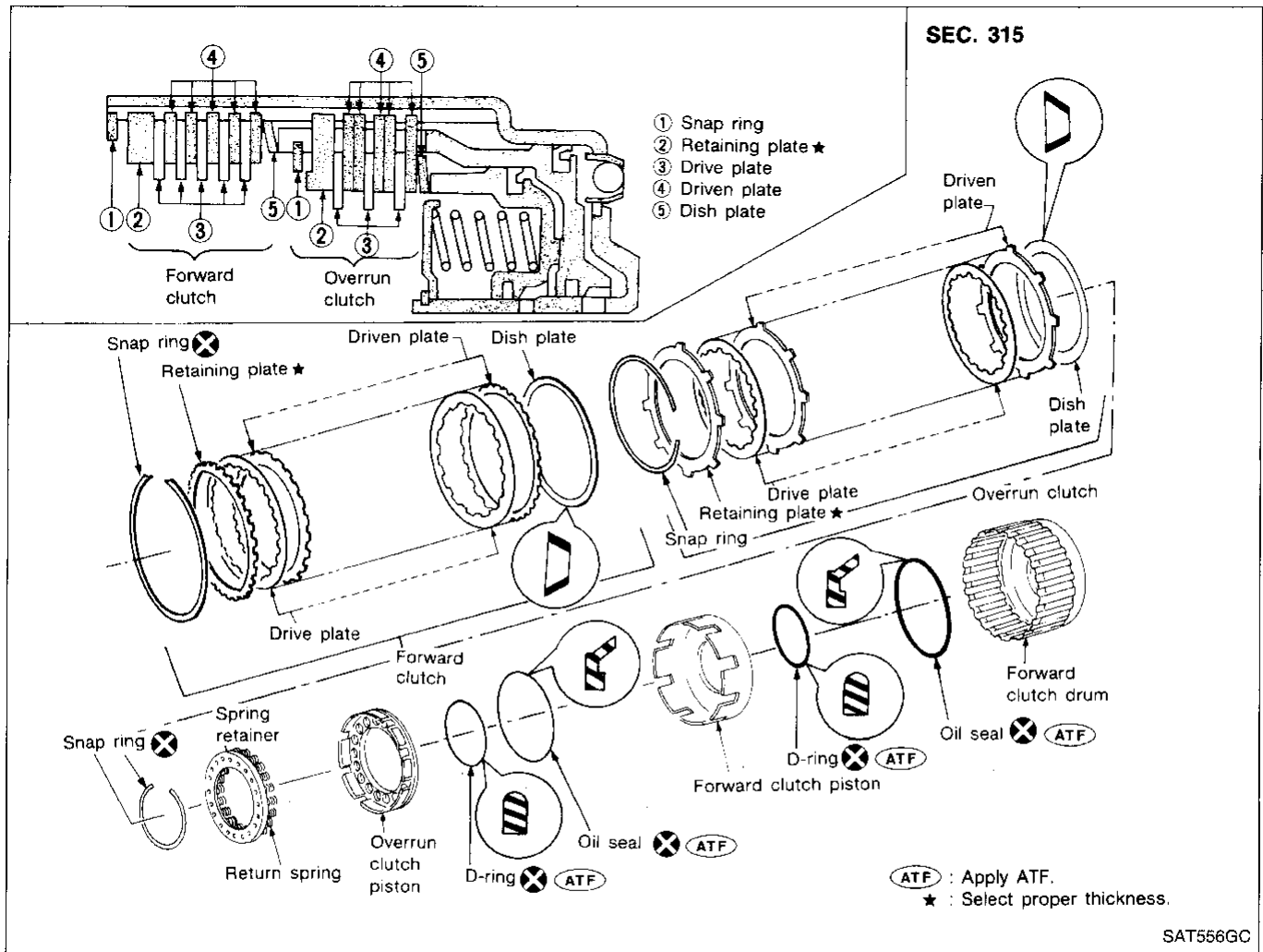

## REPAIR FOR COMPONENT PARTS

### Forward Clutch and Overrun Clutch (Cont'd) DISASSEMBLY

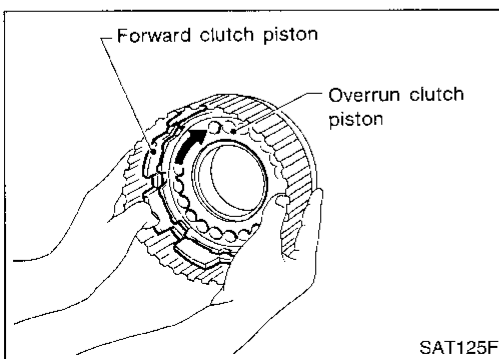
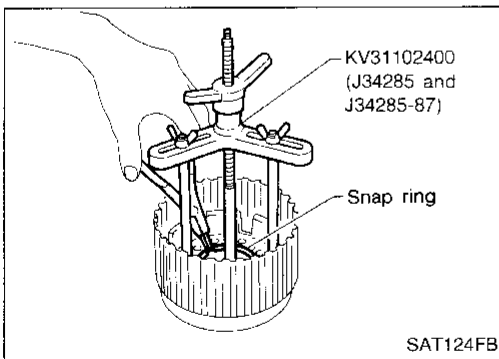
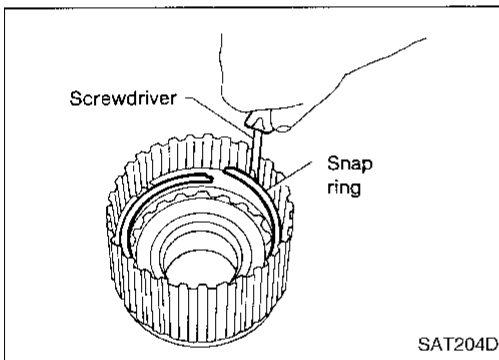
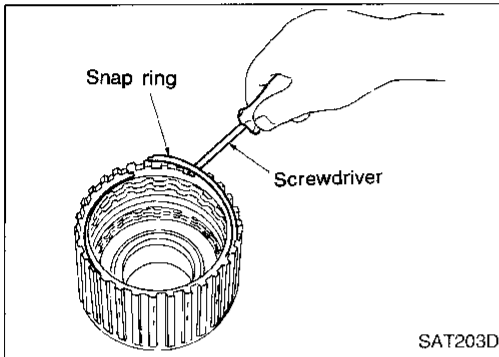
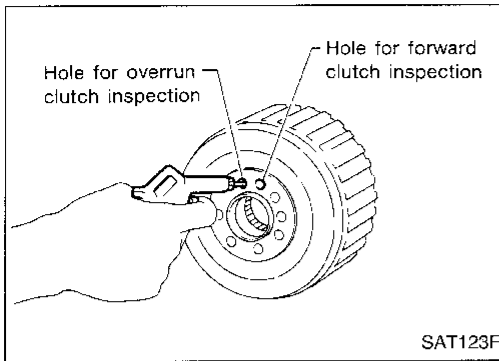

1. Check operation of forward clutch and overrun clutch.
  - a. Install bearing retainer on forward clutch drum.
  - b. Apply compressed air to oil hole of forward clutch drum.
  - c. Check to see that retaining plate moves to snap ring.
  - d. If retaining plate does not contact snap ring:
    - D-ring might be damaged.
    - Oil seal might be damaged.
    - Fluid might be leaking past piston check ball.

2. Remove snap ring for forward clutch.
3. Remove drive plates, driven plates, retaining plate and dish plate for forward clutch.

4. Remove snap ring for overrun clutch.
5. Remove drive plates, driven plates, retaining plate and dish plate for overrun clutch.

6. Set Tool on spring retainer and remove snap ring from forward clutch drum while compressing return springs.
  - **Set Tool directly over return springs.**
  - **Do not expand snap ring excessively.**
7. Remove spring retainer and return springs.
  - **Do not remove return springs from spring retainer.**

8. Remove forward clutch piston with overrun clutch piston from forward clutch drum by turning it.

GI

MA

EM

LC

EC

FE

CL

MT

AT

FA

RA

BR

ST

RS

BT

HA

EL

IDX

## REPAIR FOR COMPONENT PARTS

### Forward Clutch and Overrun Clutch (Cont'd)

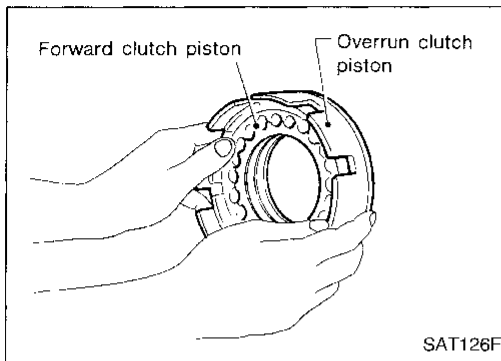

- Remove overrun clutch piston from forward clutch piston by turning it.

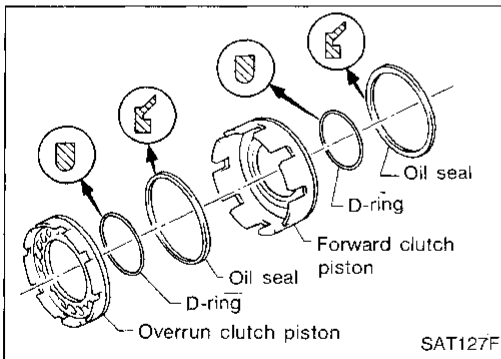

- Remove D-rings and oil seals from forward clutch piston and overrun clutch piston.

### INSPECTION

#### Snap rings, spring retainer and return springs

- Check for deformation, fatigue or damage.
- Replace if necessary.
- When replacing spring retainer and return springs, replace them as a set.**

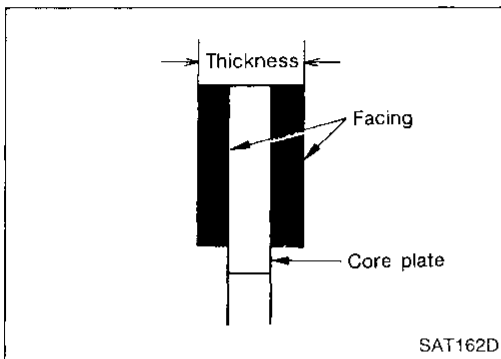

#### Forward clutch and overrun clutch drive plates

- Check facing for burns, cracks or damage.
- Measure thickness of facing.

##### Thickness of drive plate:

##### Forward clutch

Standard value: 1.6 mm (0.063 in)

Wear limit: 1.4 mm (0.055 in)

##### Overrun clutch

Standard value: 1.6 mm (0.063 in)

Wear limit: 1.4 mm (0.055 in)

- If not within wear limit, replace.

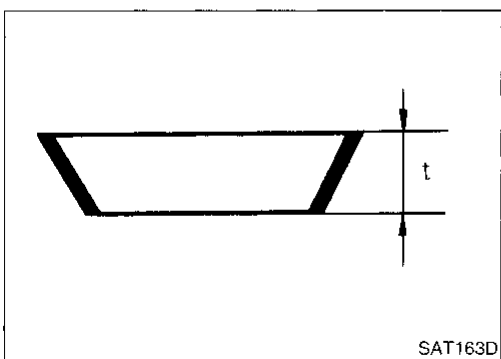

#### Forward clutch and overrun clutch dish plates

- Check for deformation or damage.
- Measure thickness of dish plate.

##### Thickness of dish plate:

Forward clutch 2.7 mm (0.106 in)

Overrun clutch 2.7 mm (0.106 in)

- If deformed or fatigued, replace.



# REPAIR FOR COMPONENT PARTS

## Forward Clutch and Overrun Clutch (Cont'd)

### Forward clutch drum

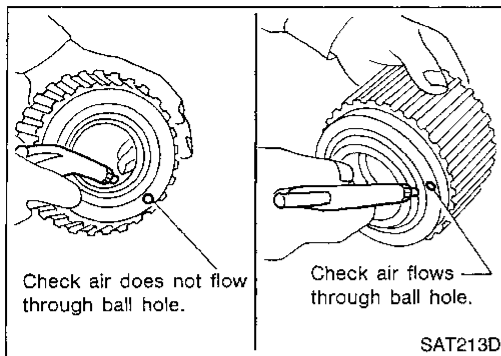

- Make sure that check balls are not fixed.
- Apply compressed air to check ball oil hole from outside of forward clutch drum. Make sure air leaks past ball.
- Apply compressed air to oil hole from inside of forward clutch drum. Make sure there is no air leakage.

GI

MA

EM

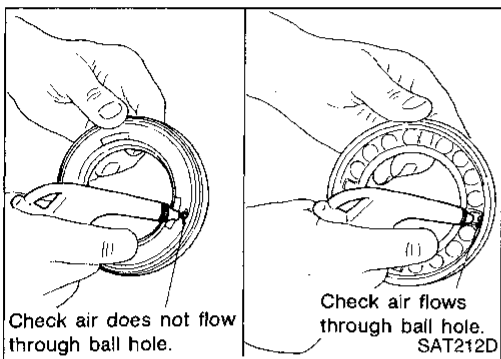

### Overrun clutch piston

- Make sure that check balls are not fixed.
- Apply compressed air to check ball oil hole opposite the return spring. Make sure there is no air leakage.
- Apply compressed air to oil hole on return spring side. Make sure that air leaks past ball.

LC

EC

FE

CL

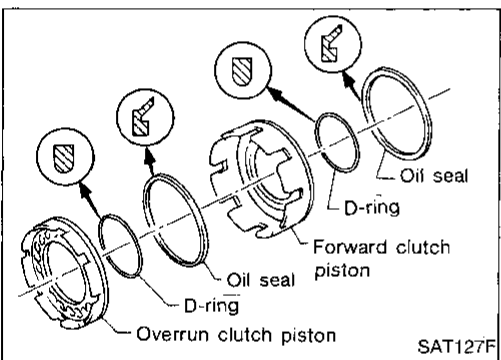

### ASSEMBLY

1. Install D-rings and oil seals on forward clutch piston and overrun clutch piston.
  - Take care with direction of lip seal.
  - Apply ATF to both parts.

MT

AT

FA

RA

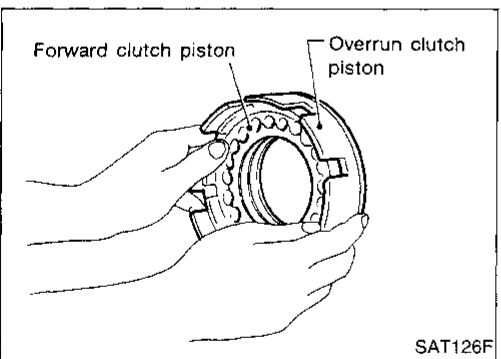

2. Install overrun clutch piston assembly on forward clutch piston by turning it slowly.
  - Apply ATF to inner surface of forward clutch piston.

BR

ST

RS

BT

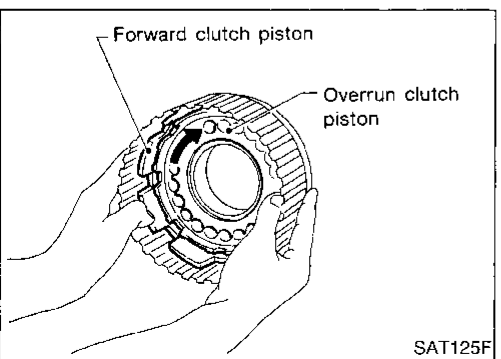

3. Install forward clutch piston assembly on forward clutch drum by turning it slowly.
  - Apply ATF to inner surface of drum.

HA

EL

IDX

## REPAIR FOR COMPONENT PARTS

### Forward Clutch and Overrun Clutch (Cont'd)

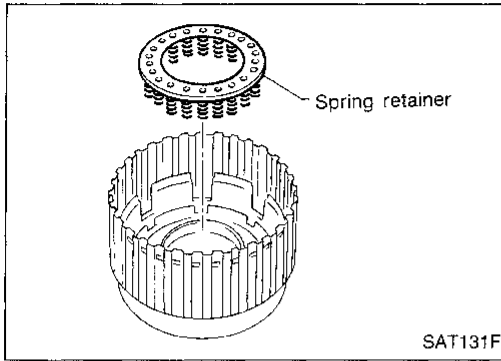

4. Install return spring on overrun clutch piston.

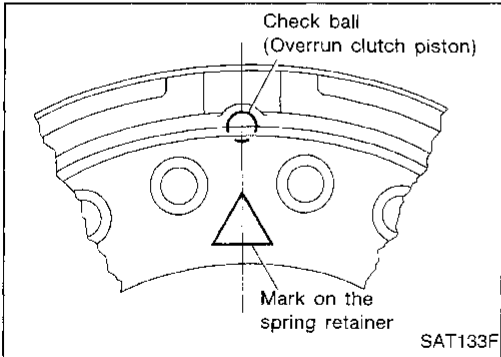

- Align the mark on spring retainer with check ball in overrun clutch piston.

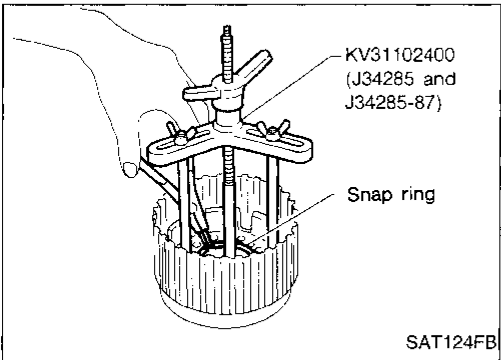

5. Set Tool on spring retainer and install snap ring while compressing return springs.

- **Set Tool directly over return springs.**

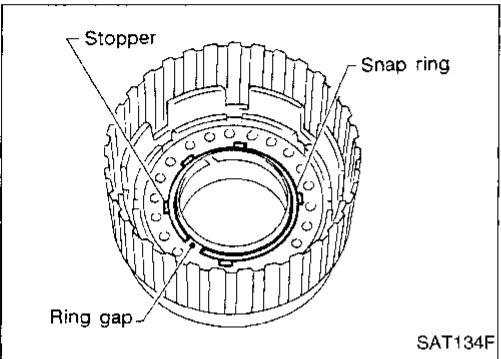

- **Do not align snap ring gap with spring retainer stopper.**

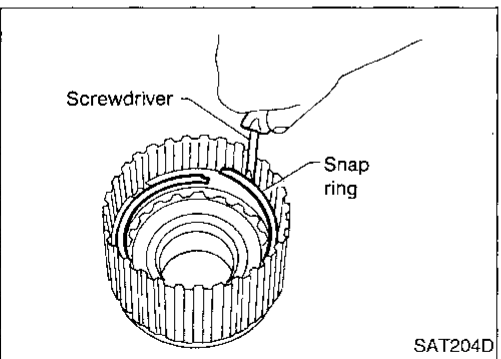

6. Install drive plates, driven plates, retaining plate and dish plate for overrun clutch.

- **Take care with order of plates.**

7. Install snap ring for overrun clutch.

## REPAIR FOR COMPONENT PARTS

### Forward Clutch and Overrun Clutch (Cont'd)

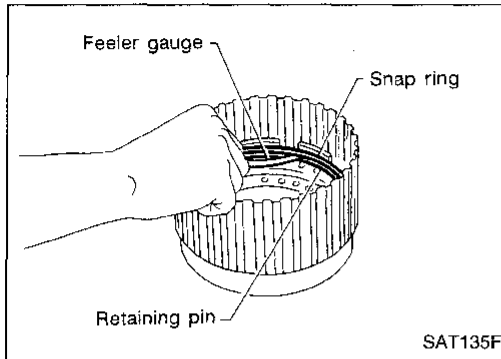

8. Measure clearance between overrun clutch retaining plate and snap ring.

If not within allowable limit, select proper retaining plate.

**Specified clearance:**

**Standard 0.7 - 1.1 mm (0.028 - 0.043 in)**

**Allowable limit 1.7 mm (0.067 in)**

**Overrun clutch retaining plate:**

**Refer to SDS, AT-226.**

GI

MA

EM

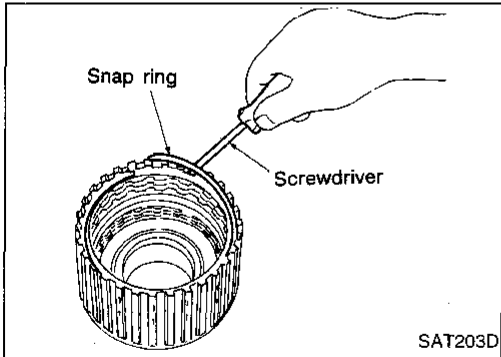

9. Install drive plates, driven plates, retaining plate and dish plate for forward clutch.

• **Take care with order of plates.**

10. Install snap ring for forward clutch.

LC

EC

FE

CL

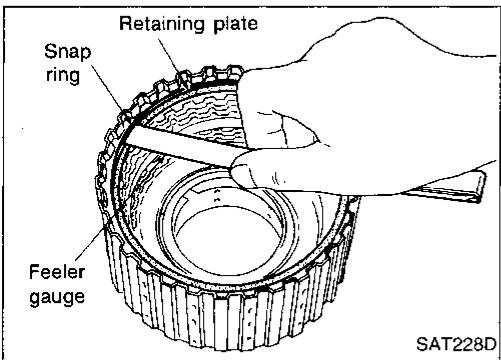

11. Measure clearance between forward clutch retaining plate and snap ring.

If not within allowable limit, select proper retaining plate.

**Specified clearance:**

**Standard 0.45 - 0.85 mm (0.0177 - 0.0335 in)**

**Allowable limit 1.85 mm (0.0728 in)**

**Forward clutch retaining plate:**

**Refer to SDS, AT-226.**

MT

AT

FA

RA

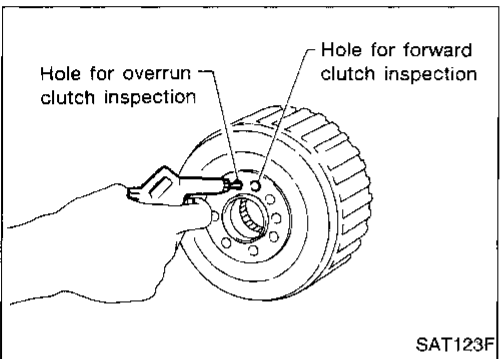

12. Check operation of forward clutch.

Refer to "DISASSEMBLY" of Forward Clutch and Overrun Clutch. AT-175

13. Check operation of overrun clutch.

Refer to "DISASSEMBLY", "Forward Clutch and Overrun Clutch", AT-175.

BR

ST

RS

BT

HA

EL

IDX

## Low & Reverse Brake

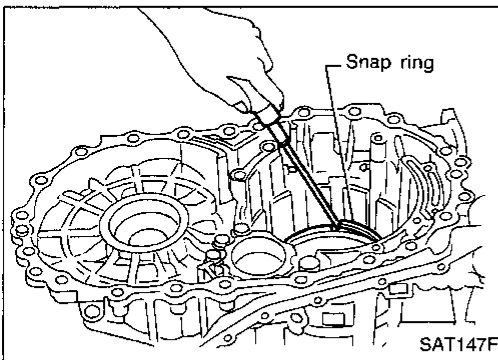
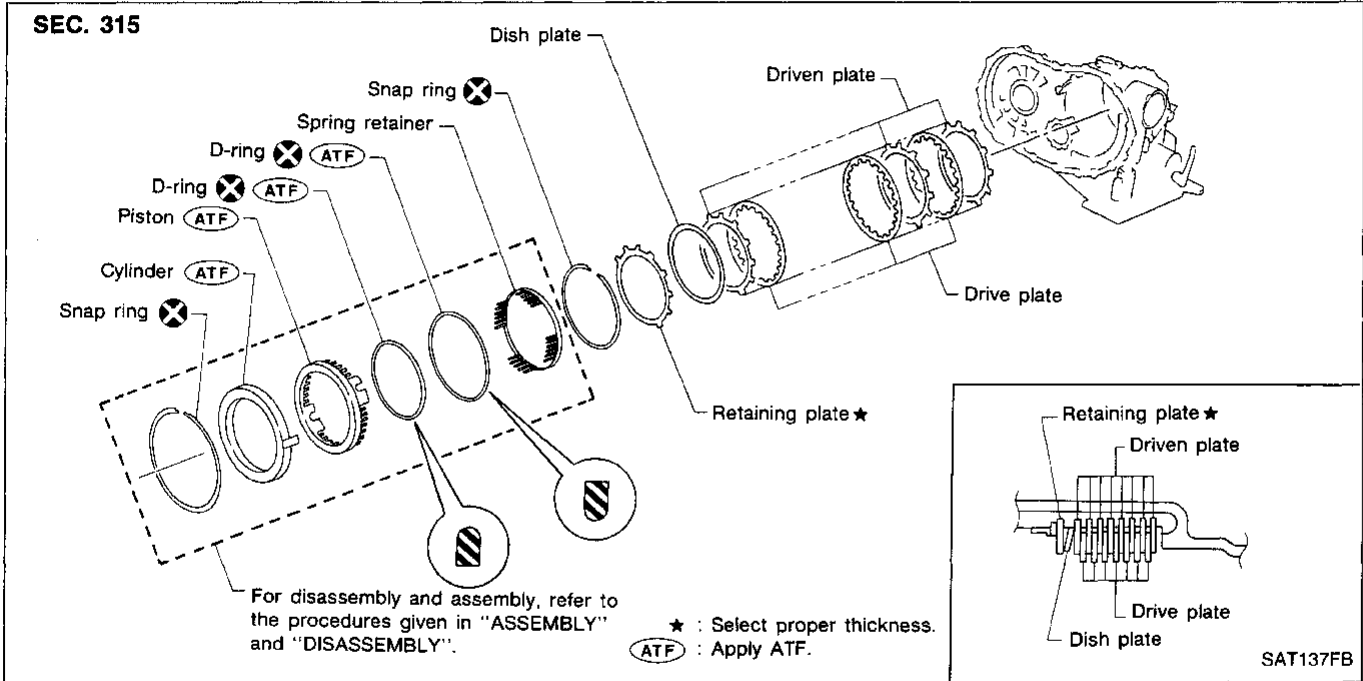

### DISASSEMBLY

1. Check operation of low & reverse brake.
  - a. Apply compressed air to oil hole of transmission case.
  - b. Check to see that retaining plate moves to snap ring.
  - c. If retaining plate does not contact snap ring:
    - D-ring might be damaged.
    - Oil seal might be damaged.
    - Fluid might be leaking past piston check ball.

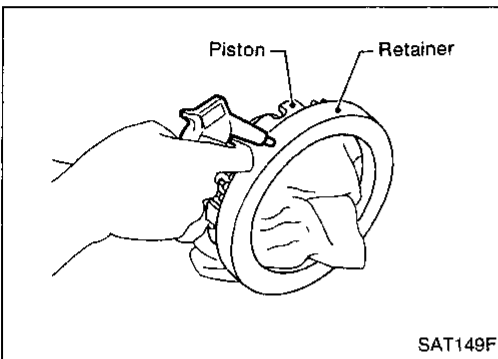

4. In order to remove piston, apply compressed air to oil hole of retainer while holding piston.
  - **Apply air gradually and allow piston to come out evenly.**

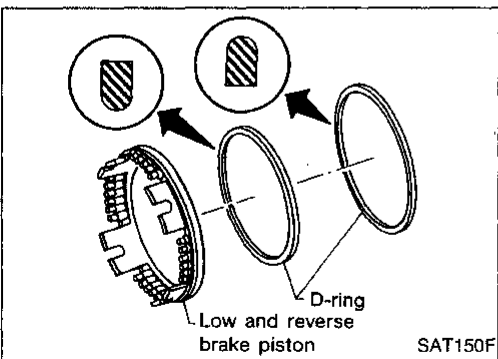

5. Remove D-rings from piston.

# REPAIR FOR COMPONENT PARTS

## Low & Reverse Brake (Cont'd)

### INSPECTION

#### Low & reverse clutch snap ring, spring retainer and return springs

- Check for deformation, fatigue or damage. If necessary, replace.
- **When replacing spring retainer and return springs, replace them as a set.**

GI

MA

EM

LC

EC

FE

CL

MT

AT

FA

RA

BR

ST

RS

BT

HA

EL

IDX

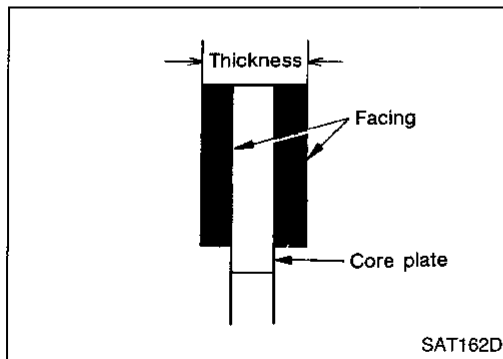

#### Low & reverse brake drive plate

- Check facing for burns, cracks or damage.
- Measure thickness of facing.  
**Thickness of drive plate:**  
**Standard value 1.8 mm (0.071 in)**  
**Wear limit 1.6 mm (0.063 in)**
- If not within wear limit, replace.

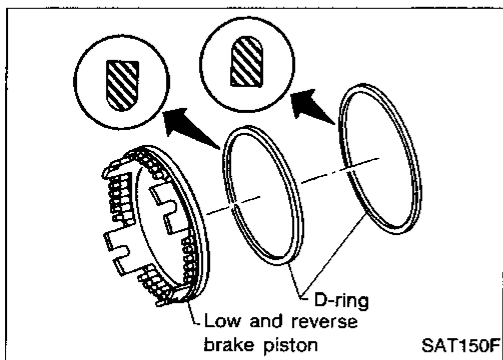

### ASSEMBLY

1. Install D-rings on piston.
  - **Take care with the direction of oil seal.**
  - **Apply ATF to both parts.**

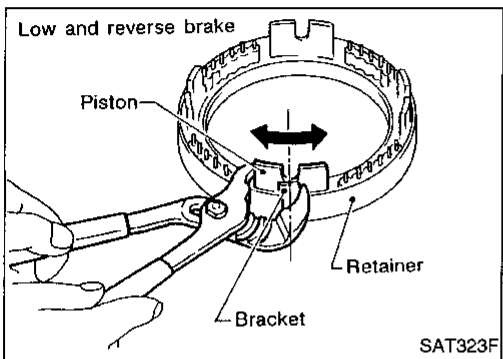

2. Set and align piston with retainer.
  - **This operation is required in order to engage the protrusions of piston to return springs correctly.**  
**Further procedures are given in "ASSEMBLY".**

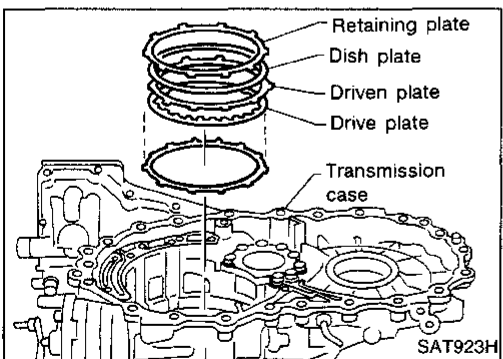

3. Install driven plates, drive plates, dish plate and retaining plate on transmission case.
  - **Take care with order of plates and direction of dish plate.**

## REPAIR FOR COMPONENT PARTS

### Low & Reverse Brake (Cont'd)

4. Install snap ring.

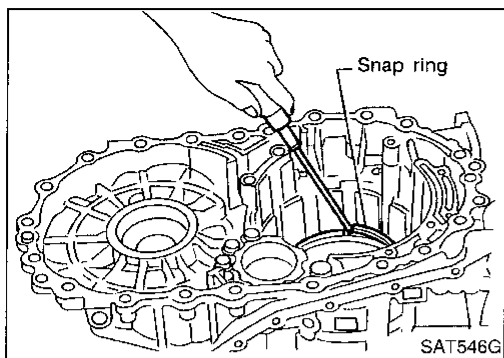

5. Measure clearance between driven plate and transmission case. If not within allowable limit, select proper retaining plate. (front side)

**Specified clearance:**

**Standard 1.7 - 2.1 mm (0.067 - 0.083 in)**

**Allowable limit 3.5 mm (0.138 in)**

**Retaining plate:**

**Refer to SDS, AT-226.**

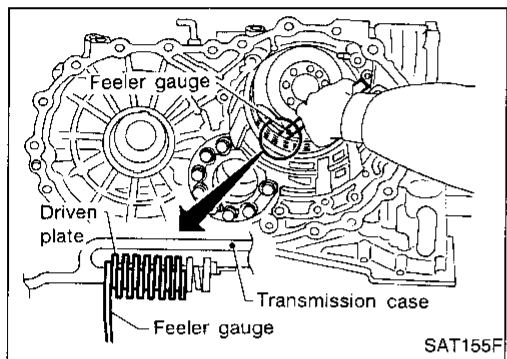

### Rear Internal Gear, Forward Clutch Hub and Overrun Clutch Hub

#### SEC. 315

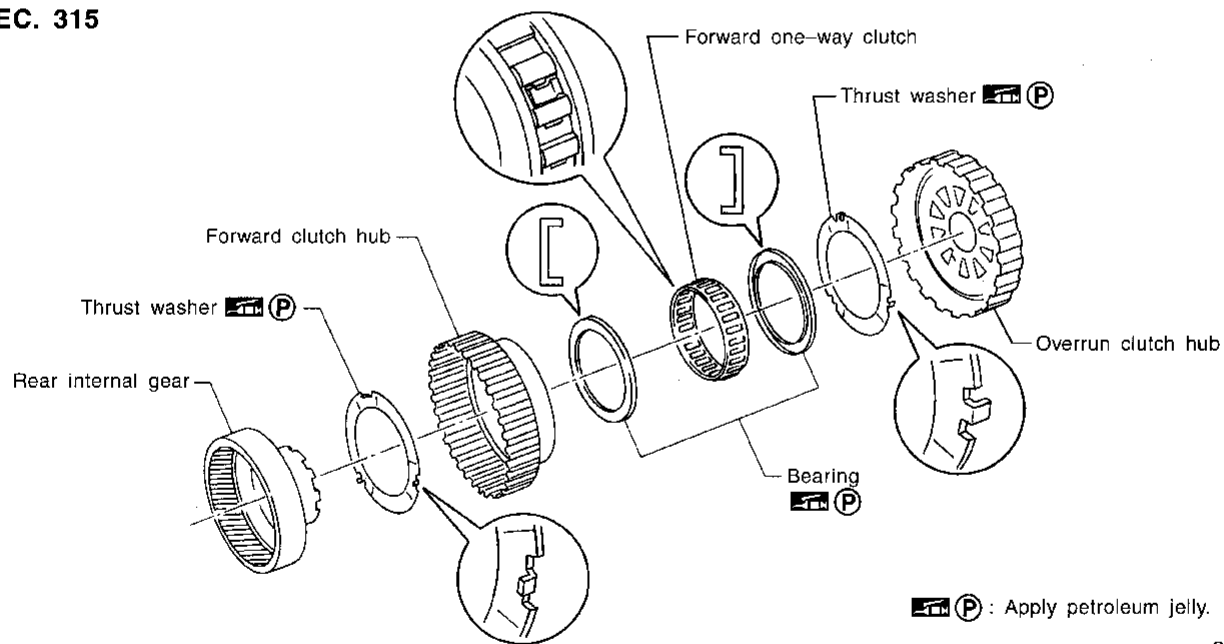

 (P) : Apply petroleum jelly.

SAT975H

## REPAIR FOR COMPONENT PARTS

### Rear Internal Gear, Forward Clutch Hub and Overrun Clutch Hub (Cont'd)

#### DISASSEMBLY

1. Remove overrun clutch hub and thrust washer from forward clutch hub.

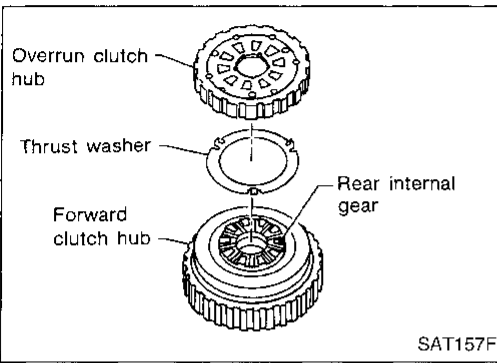

2. Remove forward clutch hub from rear internal gear.

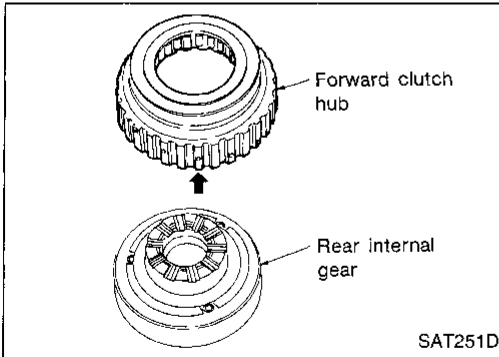

3. Remove bearing from rear internal gear.

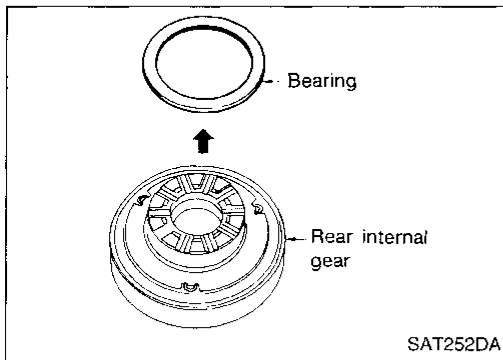

4. Remove thrust washer from rear internal gear.

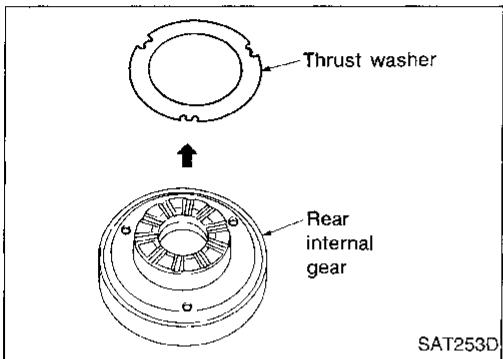

5. Remove bearing from forward one-way clutch.

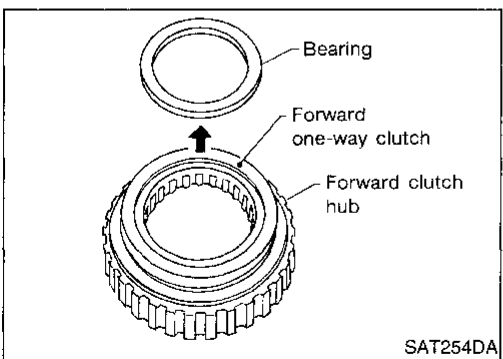

GI

MA

EM

LC

EC

FE

CL

MT

AT

FA

RA

BR

ST

RS

BT

HA

EL

IDX

## REPAIR FOR COMPONENT PARTS

### Rear Internal Gear, Forward Clutch Hub and Overrun Clutch Hub (Cont'd)

6. Remove forward one-way clutch from forward clutch hub.

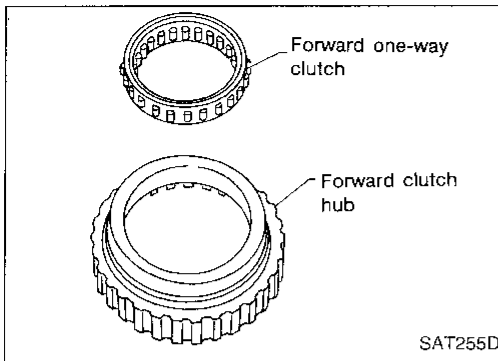

### INSPECTION

#### Rear internal gear, forward clutch hub and overrun clutch hub

- Check rubbing surfaces for wear or damage.

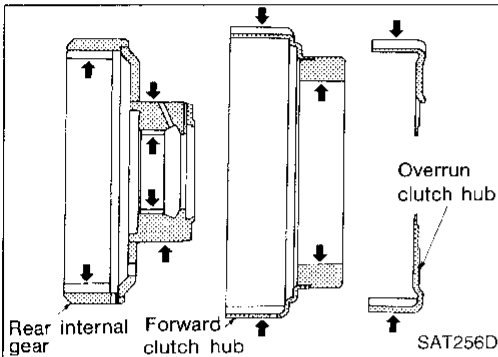

#### Bearings and forward one-way clutch

- Check bearings for deformation and damage.
- Check forward one-way clutch for wear and damage.

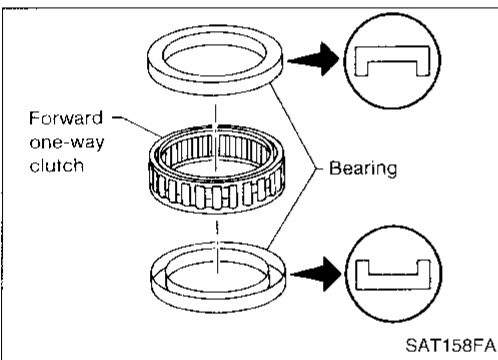

### ASSEMBLY

1. Install forward one-way clutch on forward clutch.
  - **Take care with the direction of forward one-way clutch.**

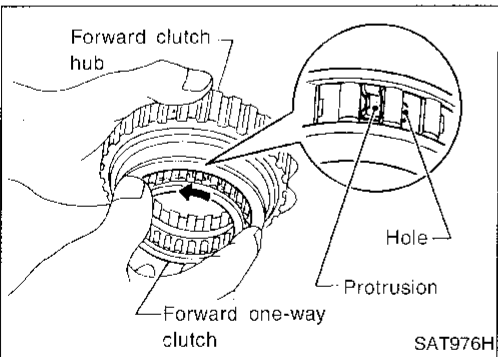

2. Install bearing on forward one-way clutch.
  - **Apply petroleum jelly to bearing.**

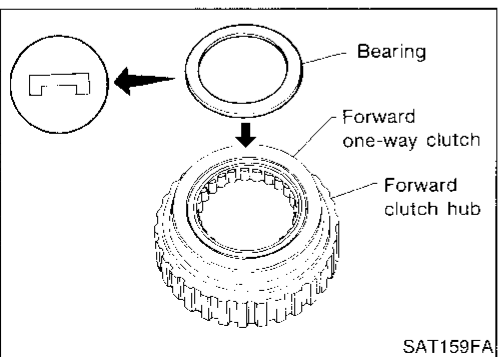



## REPAIR FOR COMPONENT PARTS

### Rear Internal Gear, Forward Clutch Hub and Overrun Clutch Hub (Cont'd)

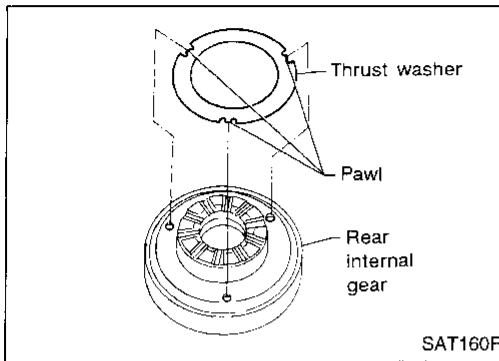

3. Install thrust washer on rear internal gear.
  - Apply petroleum jelly to thrust washer.
  - Align hooks of thrust washer with holes of rear internal gear.

GI

MA

EM

LC

EC

FE

CL

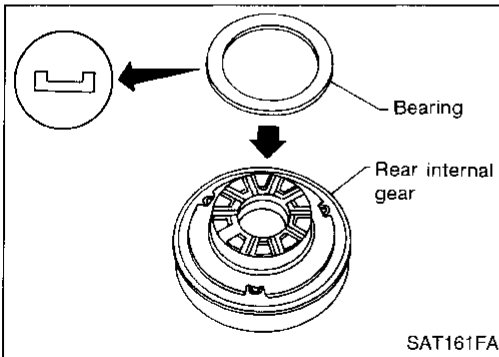

4. Install bearing on rear internal gear.
  - Apply petroleum jelly to bearing.

MT

AT

FA

RA

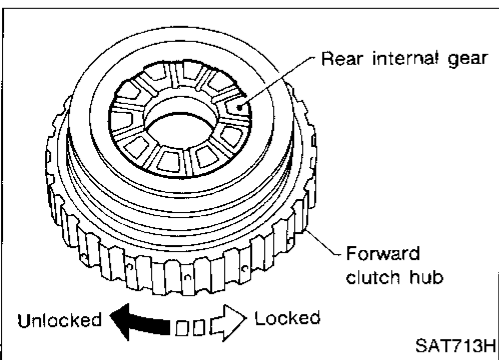

5. Install forward clutch hub on rear internal gear.
  - Check operation of forward one-way clutch. Hold rear internal gear and turn forward clutch hub. Check forward clutch hub for correct locking and unlocking directions.
  - If not as shown in illustration, check installation direction of forward one-way clutch.

BR

ST

RS

BT

HA

EL

IDX

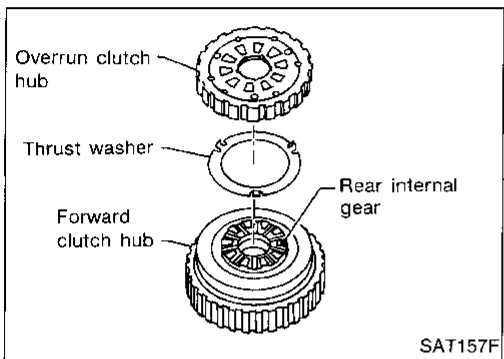

6. Install thrust washer and overrun clutch hub.
  - Apply petroleum jelly to thrust washer.
  - Align hooks of thrust washer with holes of overrun clutch hub.
  - Align projections of rear internal gear with holes of overrun clutch hub.

Output Shaft, Idler Gear, Reduction Pinion Gear and Bearing Retainer

SEC. 314

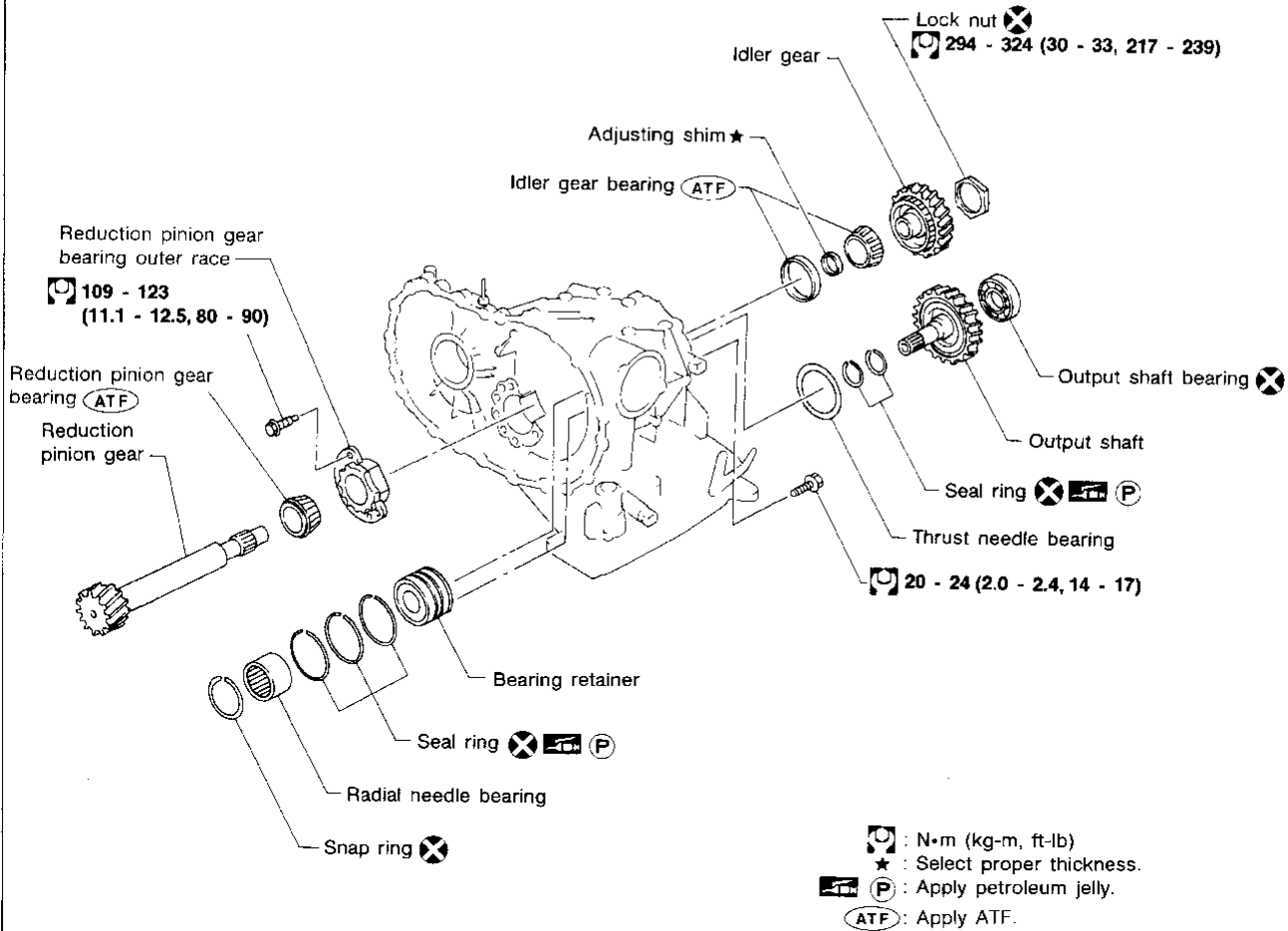

SAT557GB

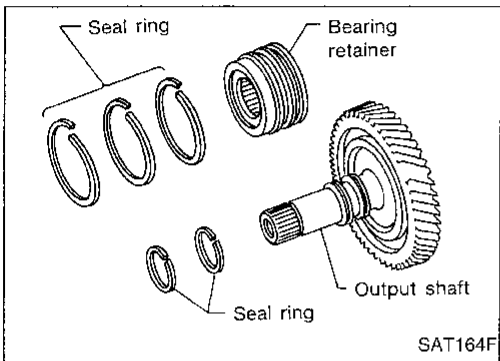

DISASSEMBLY

1. Remove seal rings from output shaft and bearing retainer.

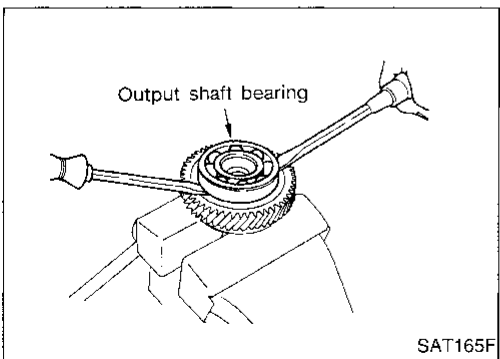

2. Remove output shaft bearing with screwdrivers.

- Always replace bearing with a new one when removed.
- Do not damage output shaft.

## REPAIR FOR COMPONENT PARTS

### Output Shaft, Idler Gear, Reduction Pinion Gear and Bearing Retainer (Cont'd)

3. Remove snap ring from bearing retainer.

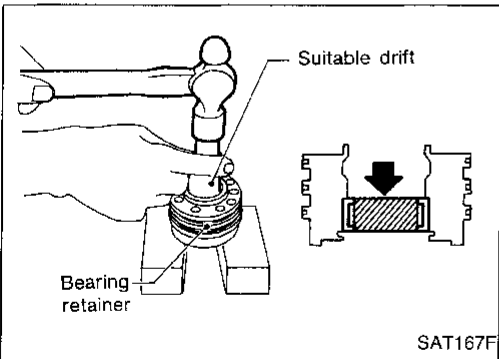
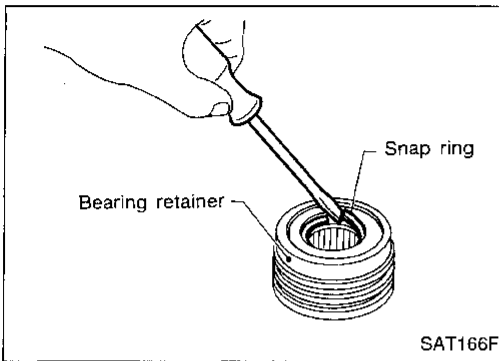

4. Remove needle bearing from bearing retainer.

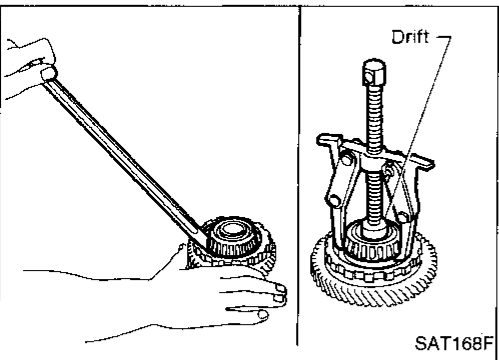

5. Remove idler gear bearing inner race from idler gear.

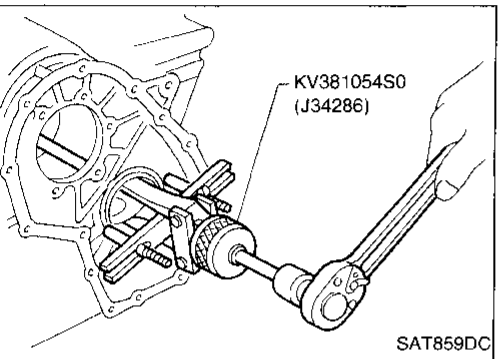

6. Remove idler gear bearing outer race from transmission case.

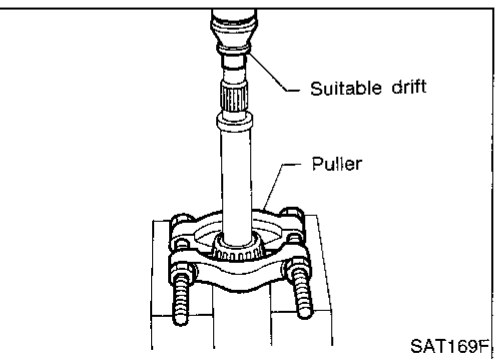

7. Press out reduction pinion gear bearing inner race from reduction pinion gear.

GI

MA

EM

LC

EC

FE

CL

MT

AT

FA

RA

BR

ST

RS

BT

HA

EL

IDX

## REPAIR FOR COMPONENT PARTS

### Output Shaft, Idler Gear, Reduction Pinion Gear and Bearing Retainer (Cont'd)

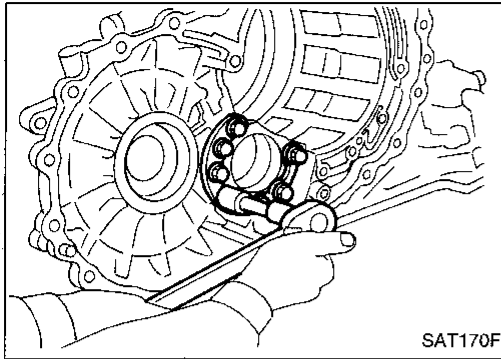

8. Remove reduction pinion gear bearing outer race from transmission case.

### INSPECTION

#### Output shaft, idler gear and reduction pinion gear

- Check shafts for cracks, wear or bending.
- Check gears for wear, chips and cracks.

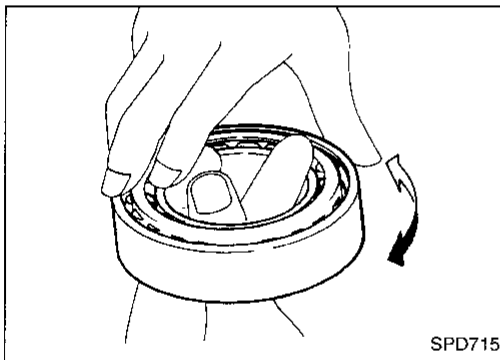

#### Bearing

- Make sure bearings roll freely and are free from noise, cracks, pitting or wear.
- **When replacing taper roller bearing, replace outer and inner race as a set.**

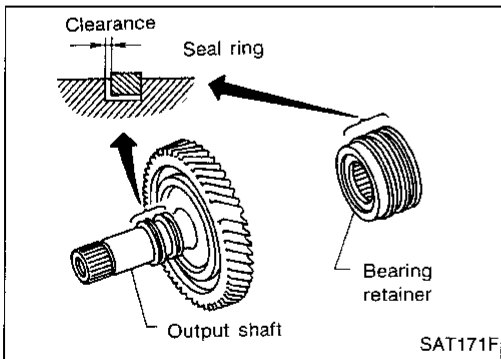

#### Seal ring clearance

- Install new seal rings to output shaft.
- Measure clearance between seal ring and ring groove of output shaft.

##### Standard clearance:

**0.10 - 0.25 mm (0.0039 - 0.0098 in)**

##### Allowable limit:

**0.25 mm (0.0098 in)**

- If not within allowable limit, replace output shaft.
- Install new seal rings to bearing retainer.
- Measure clearance between seal ring and ring groove of bearing retainer.

##### Standard clearance:

**0.10 - 0.30 mm (0.0039 - 0.0118 in)**

##### Allowable limit:

**0.30 mm (0.0118 in)**

- If not within allowable limit, replace bearing retainer.

## REPAIR FOR COMPONENT PARTS

### Output Shaft, Idler Gear, Reduction Pinion Gear and Bearing Retainer (Cont'd)

#### ASSEMBLY

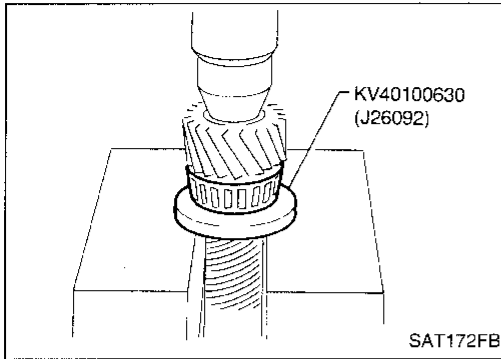

1. Press reduction pinion gear bearing inner race on reduction pinion gear.

GI

MA

EM

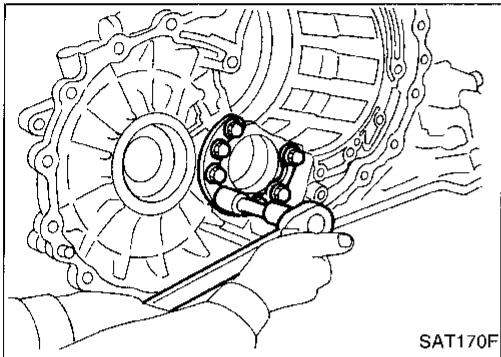

2. Install reduction pinion gear bearing outer race on transmission case.

LC

EC

FE

CL

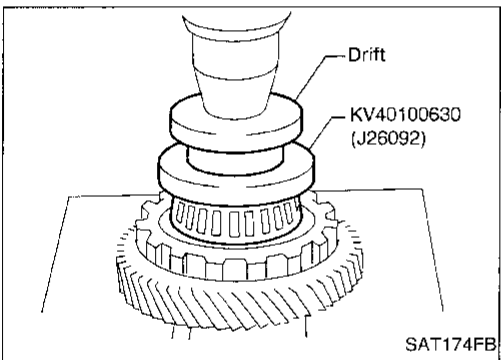

3. Press idler gear bearing inner race on idler gear.

MT

AT

FA

RA

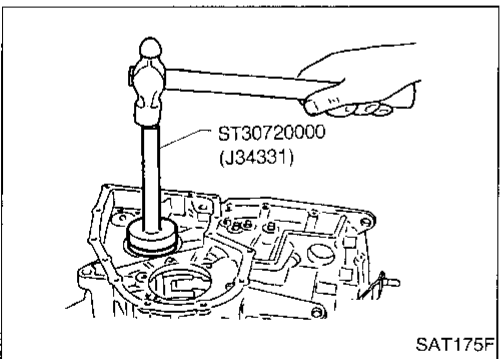

4. Install idler gear bearing outer race on transmission case.

BR

ST

RS

BT

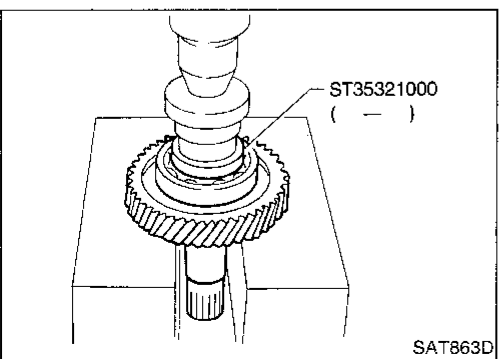

5. Press output shaft bearing on output shaft.

HA

EL

IDX

## REPAIR FOR COMPONENT PARTS

### Output Shaft, Idler Gear, Reduction Pinion Gear and Bearing Retainer (Cont'd)

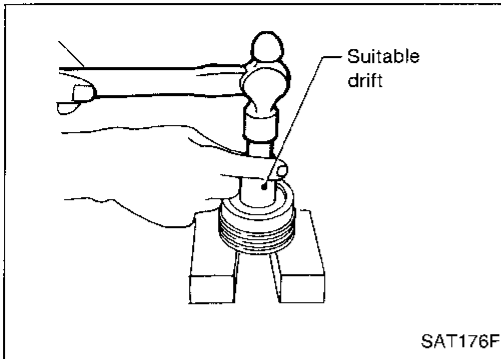

6. Press needle bearing on bearing retainer.

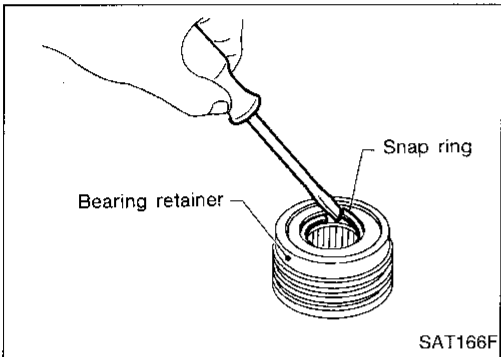

7. Install snap ring to bearing retainer.

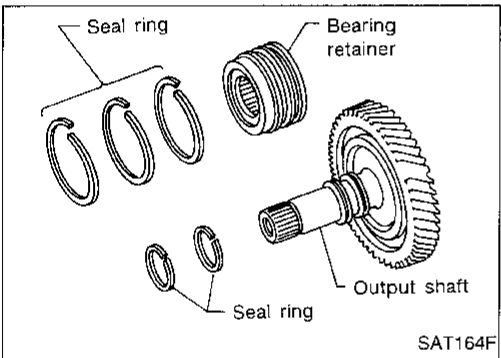

8. After packing ring grooves with petroleum jelly, carefully install new seal rings on output shaft and bearing retainer.

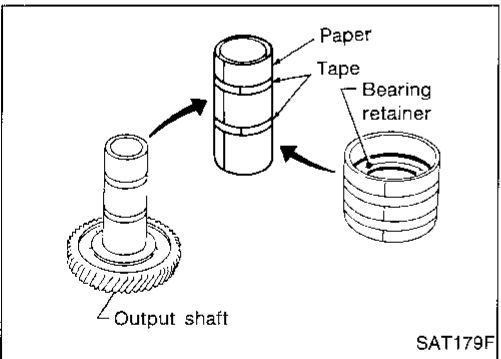

- Roll paper around seal rings to prevent seal rings from spreading.

Band Servo Piston Assembly

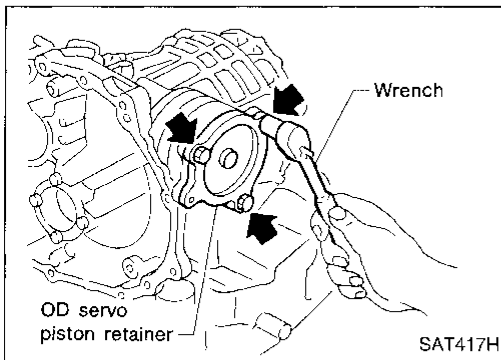
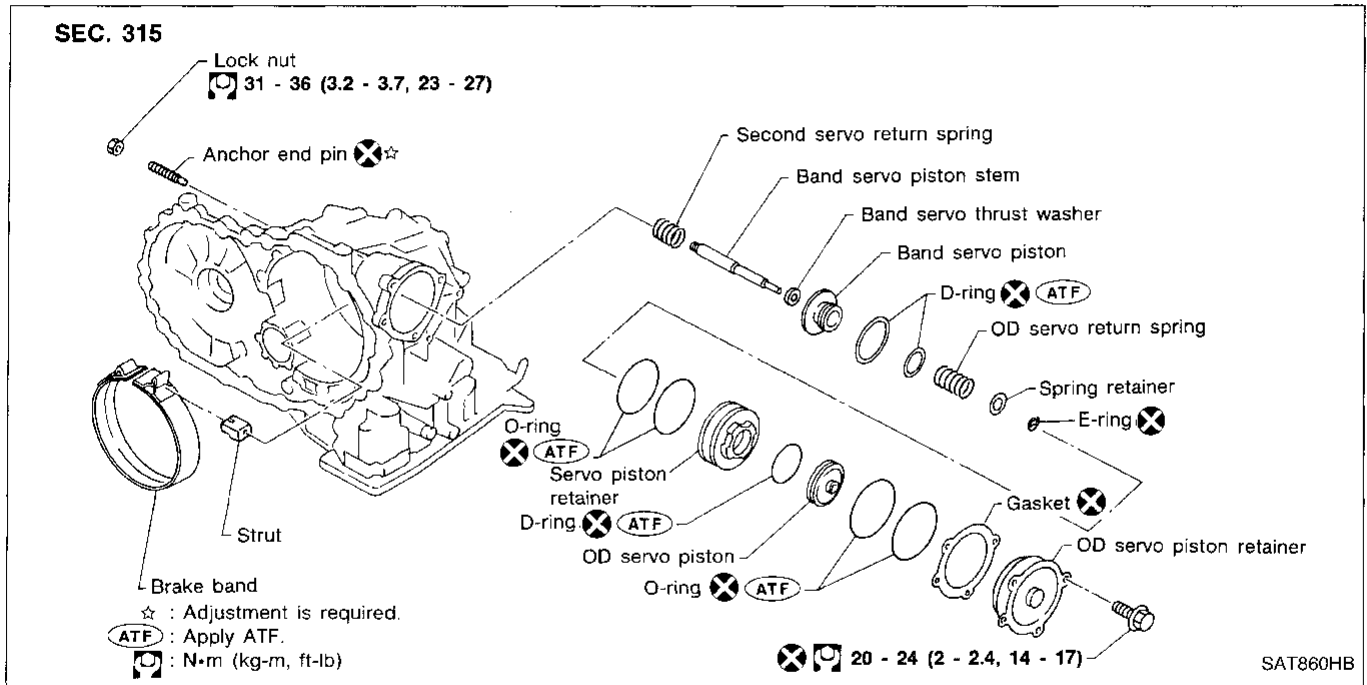

DISASSEMBLY

1. Remove band servo piston fixing bolts.

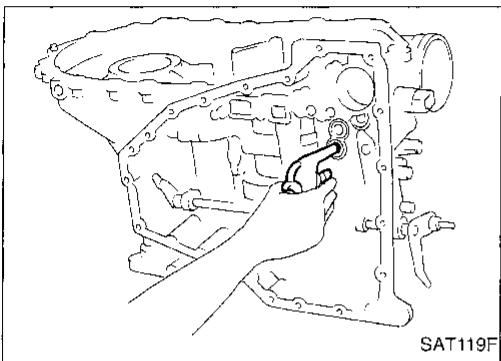

2. Apply compressed air to oil hole in transmission case to remove OD servo piston retainer and band servo piston assembly.

- Hold band servo piston assembly with a rag or nylon waste.

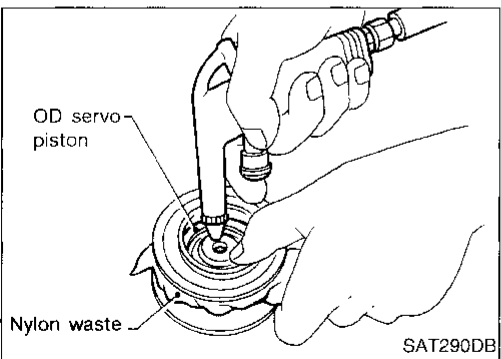

3. Apply compressed air to oil hole in OD servo piston retainer to remove OD servo piston from retainer.

- Hold OD servo piston while applying compressed air.

## REPAIR FOR COMPONENT PARTS

### Band Servo Piston Assembly (Cont'd)

4. Remove D-ring from OD servo piston.

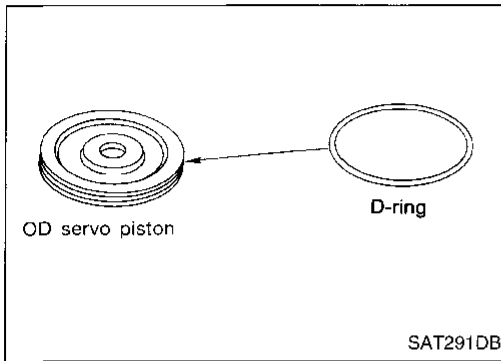

5. Remove O-rings from OD servo piston retainer.

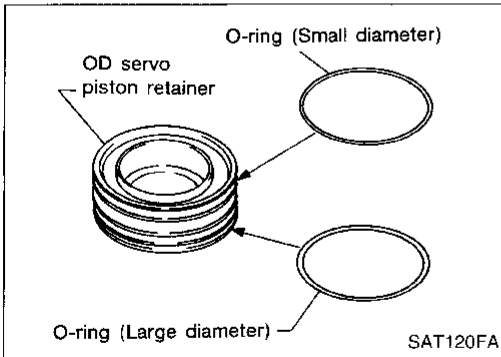

6. Remove band servo piston assembly from servo piston retainer by pushing it forward.

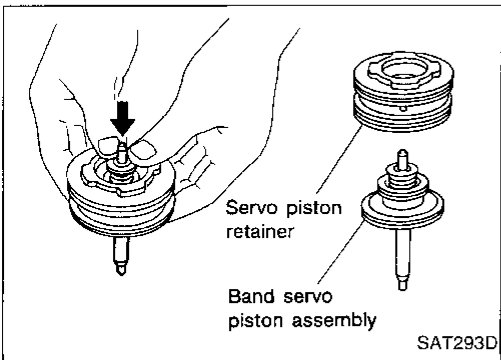

7. Place piston stem end on a wooden block. While pushing servo piston spring retainer down, remove E-ring.

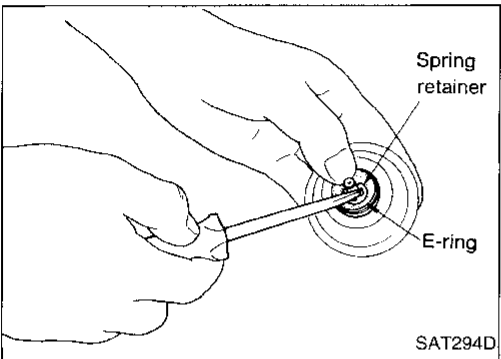

8. Remove OD servo return spring, band servo thrust washer and band servo piston stem from band servo piston.

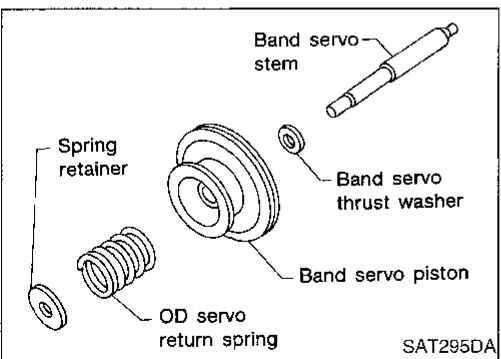



# REPAIR FOR COMPONENT PARTS

## Band Servo Piston Assembly (Cont'd)

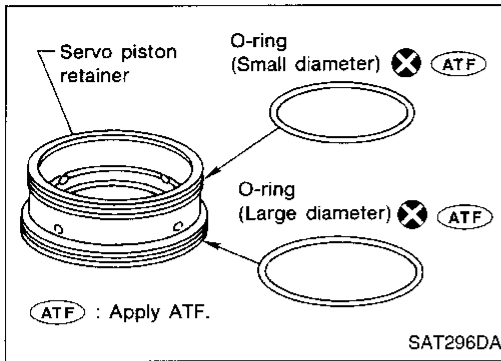

9. Remove O-rings from servo piston retainer.

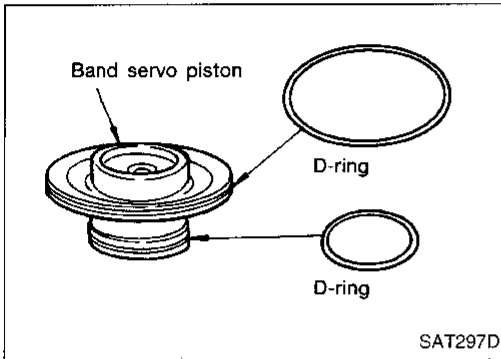

10. Remove D-rings from band servo piston.

### INSPECTION

#### Pistons, retainers and piston stem

- Check frictional surfaces for abnormal wear or damage.

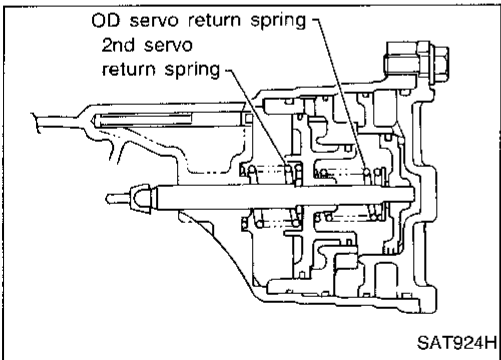

#### Return springs

- Check for deformation or damage.
  - Measure free length and outer diameter.
- Inspection standard:**  
Refer to SDS, AT-229.

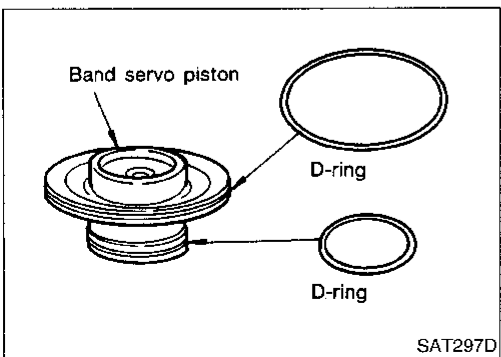

### ASSEMBLY

1. Install D-rings to servo piston retainer.
- Apply ATF to D-rings.
  - Pay attention to position of each O-ring.

CI

MA

EM

LC

EC

FE

CL

WT

AT

FA

RA

BR

ST

BS

BT

HA

EL

IDX

## REPAIR FOR COMPONENT PARTS

### Band Servo Piston Assembly (Cont'd)

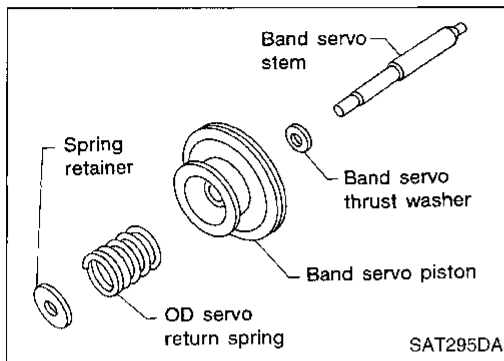

2. Install band servo piston stem, band servo thrust washer, OD servo return spring and spring retainer to band servo piston.

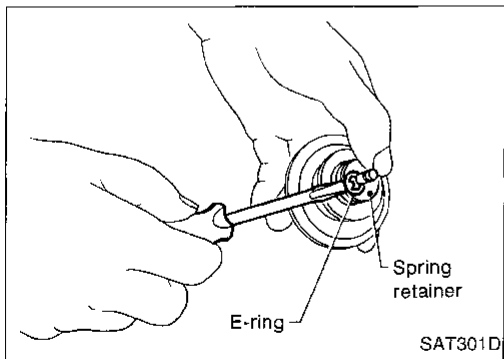

3. Place piston stem end on a wooden block. While pushing servo piston spring retainer down, install E-ring.

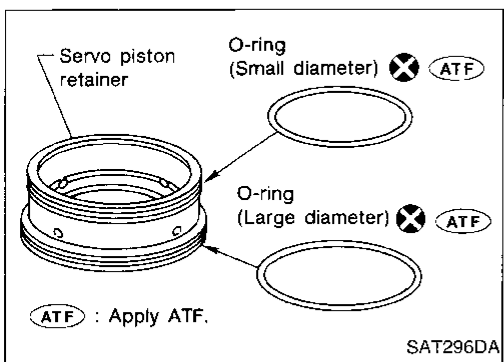

4. Install O-rings to servo piston retainer.
  - **Apply ATF to O-rings.**
  - **Pay attention to position of each O-ring.**

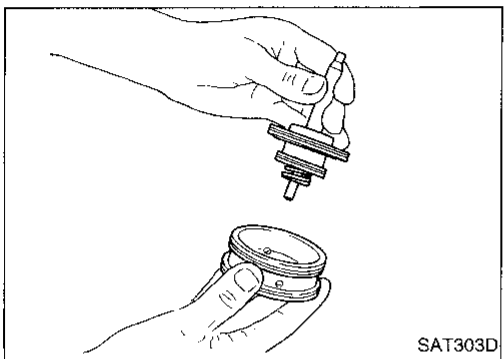

5. Install band servo piston assembly to servo piston retainer by pushing it inward.

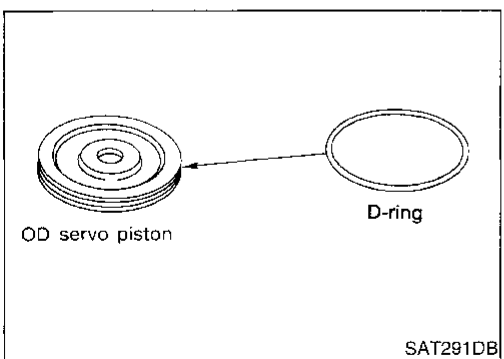

6. Install D-ring to OD servo piston.
  - **Apply ATF to D-ring.**

## REPAIR FOR COMPONENT PARTS

### Band Servo Piston Assembly (Cont'd)

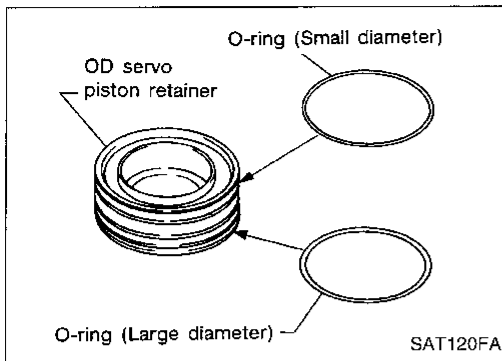

7. Install O-rings to OD servo piston retainer.
  - **Apply ATF to O-rings.**
  - **Pay attention to position of each O-ring.**

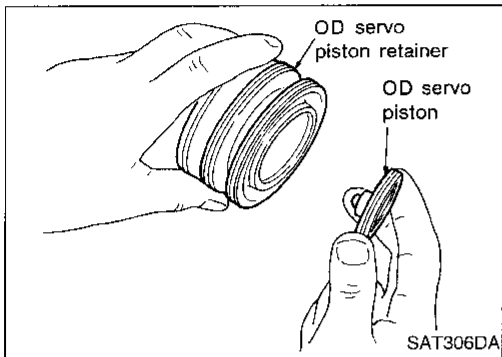

8. Install OD servo piston to OD servo piston retainer.

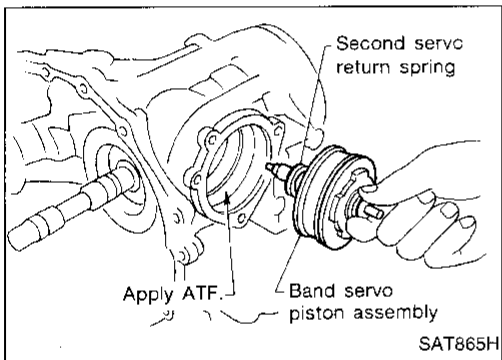

9. Install band servo piston assembly and 2nd servo return spring to transmission case.
  - **Apply ATF to O-ring of band servo piston and transmission case.**

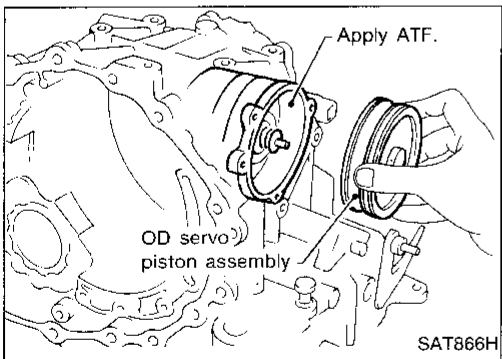

10. Install OD servo piston assembly to transmission case.
  - **Apply ATF to O-ring of band servo piston and transmission case.**

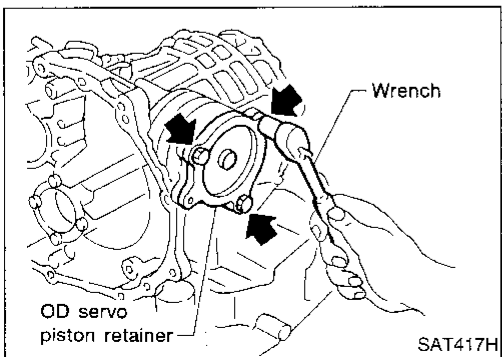

11. Install band servo piston snap ring to transmission case.

GI

WA

EM

LC

EC

FE

CL

MT

AT

FA

RA

BR

ST

RS

BT

HA

EL

IDX

## Final Drive — RE4F04A

SEC. 381

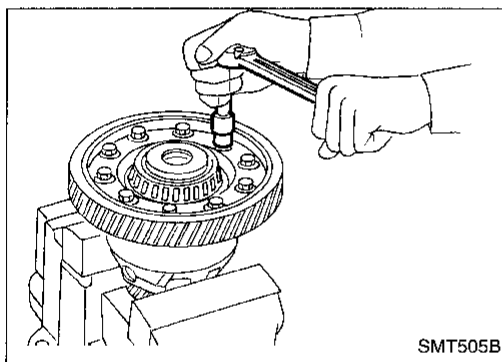
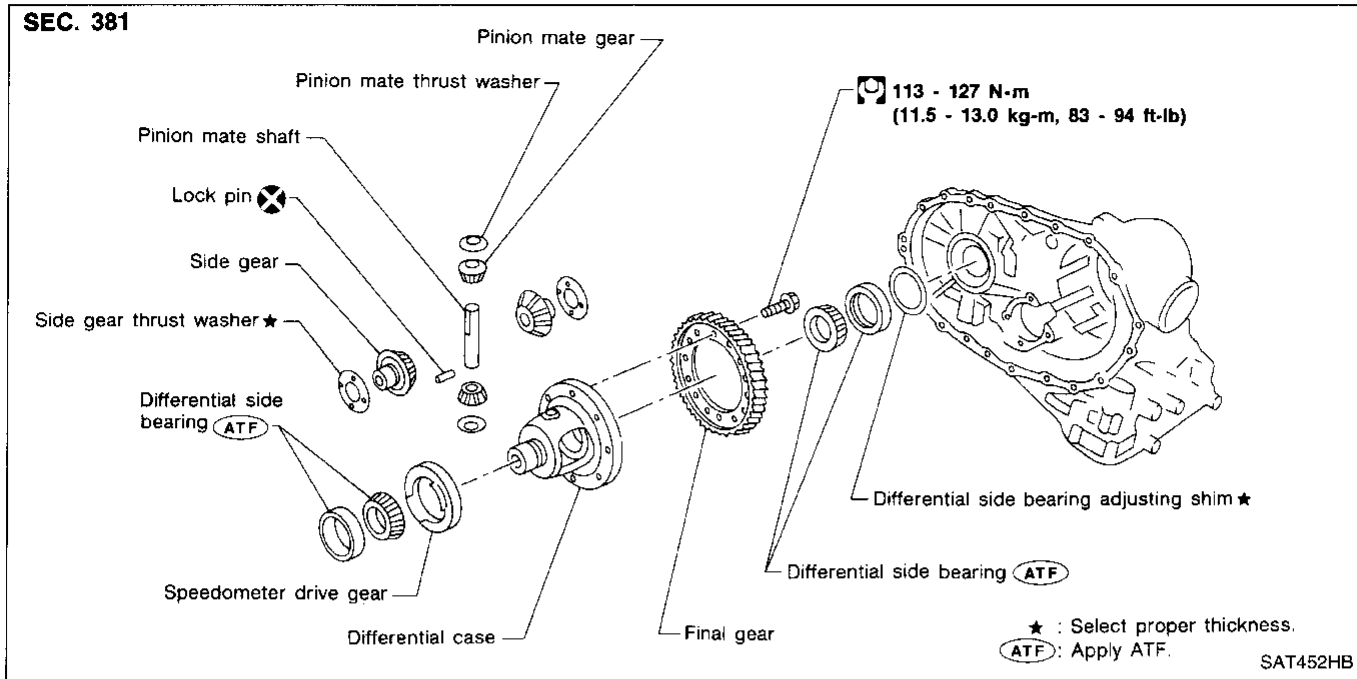

### DISASSEMBLY

1. Remove final gear.

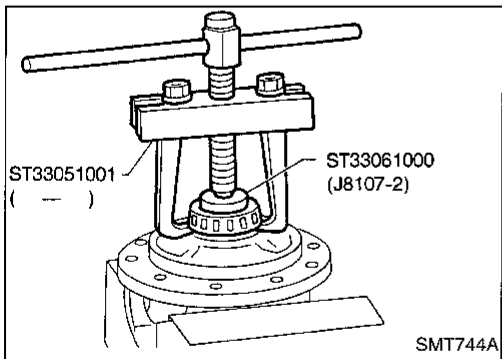

2. Press out differential side bearings.

- **Be careful not to mix up the right and left bearings.**

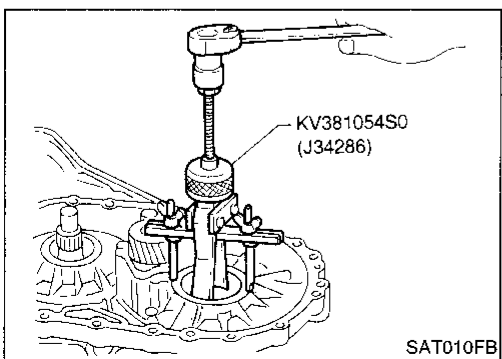

3. Remove differential side bearing outer race, and side bearing adjusting shim from transmission case.

# REPAIR FOR COMPONENT PARTS

## Final Drive — RE4F04A (Cont'd)

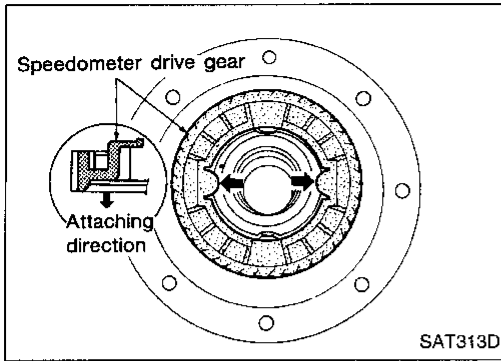

4. Remove speedometer drive gear.

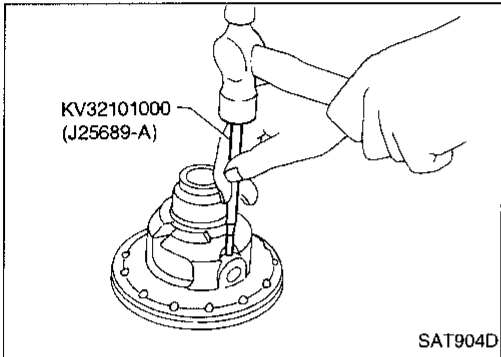

5. Drive out pinion mate shaft lock pin.

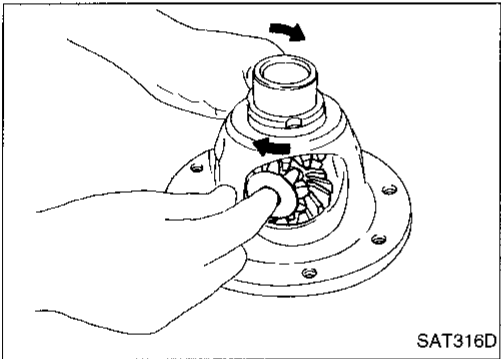

6. Draw out pinion mate shaft lock pin.

7. Remove pinion mate gears and side gears.

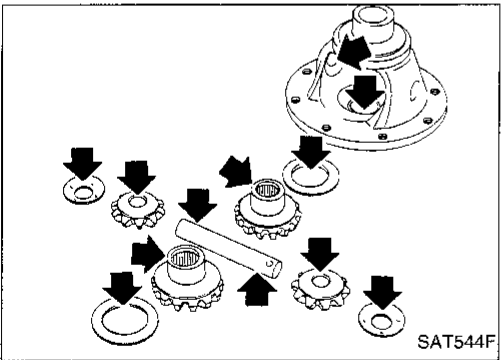

### INSPECTION

#### Gear, washer, shaft and case

- Check mating surfaces of differential case, side gears and pinion mate gears.
- Check washers for wear.

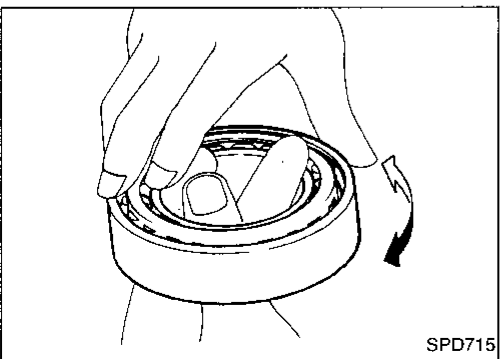

#### Bearings

- Make sure bearings roll freely and are free from noise, cracks, pitting or wear.
- **When replacing taper roller bearing, replace outer and inner race as a set.**

GI

MA

EM

LC

EC

FE

CL

MT

AT

FA

RA

BR

ST

RS

BT

HA

EL

IDX

## REPAIR FOR COMPONENT PARTS

### Final Drive — RE4F04A (Cont'd)

#### ASSEMBLY

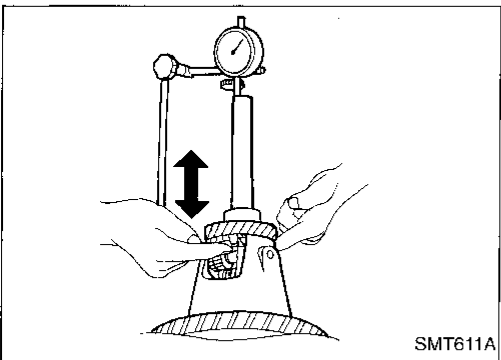
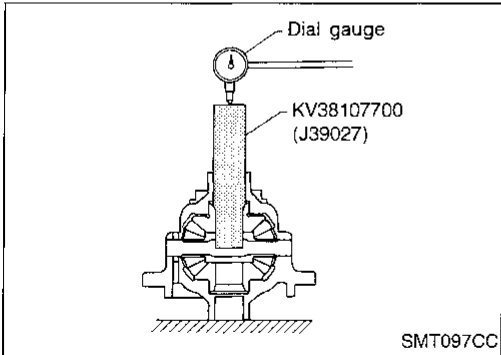
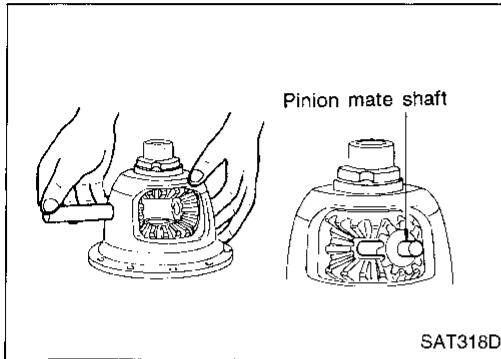

1. Install side gears and thrust washers in differential case.
2. Install pinion mate gears and thrust washers in the differential case while rotating them.
  - **When inserting, be careful not to damage pinion mate gear washers.**
  - **Apply ATF to all parts.**

3. Measure clearance between side gear and differential case with washers following the procedure below:
  - a. Set Tool and dial indicator on side gear.

- b. Move side gear up and down to measure dial indicator deflection. Always measure indicator deflection on both side gears.

**Clearance between side gear and differential case with washers:**

**0.1 - 0.2 mm (0.004 - 0.008 in)**

- c. If not within specification, adjust clearance by changing thickness of side gear thrust washers.

**Side gear thrust washer:**

**Refer to AT-227.**

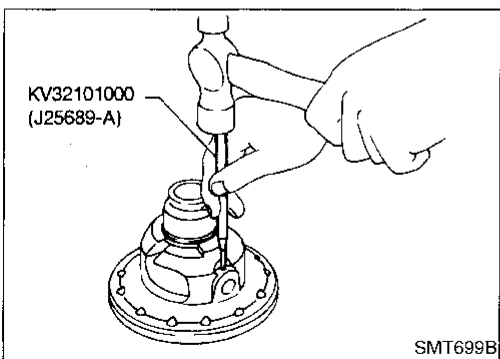

4. Install lock pin.
  - **Make sure that lock pin is flush with case.**

# REPAIR FOR COMPONENT PARTS

## Final Drive — RE4F04A (Cont'd)

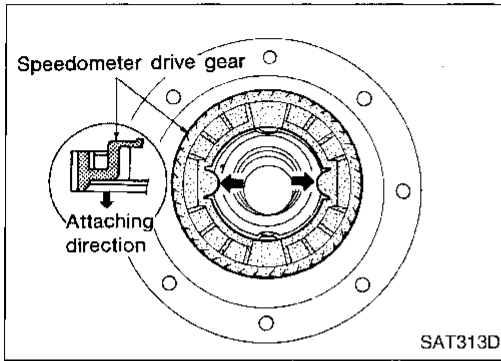

5. Install speedometer drive gear on differential case.
  - **Align the projection of speedometer drive gear with the groove of differential case.**

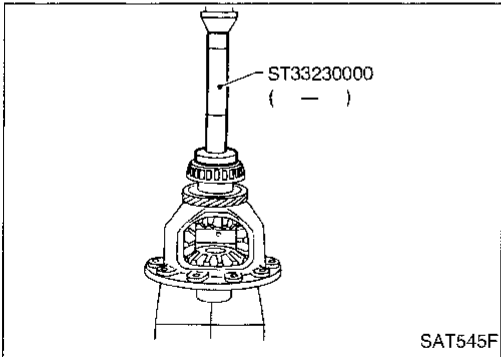

6. Press on differential side bearings.

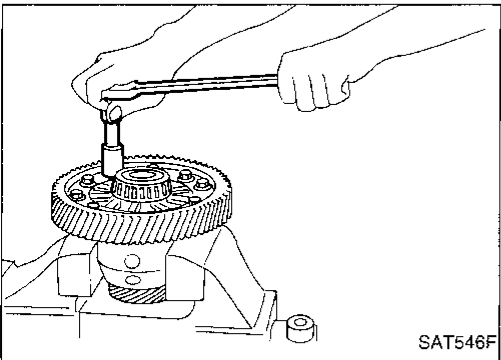

7. Install final gear and tighten fixing bolts in a crisscross pattern.

GI

MA

EM

LC

EC

FE

CL

WT

**AT**

FA

RA

BR

ST

RS

BT

HA

EL

IDX

Final Drive — RE4F04V

SEC. 381

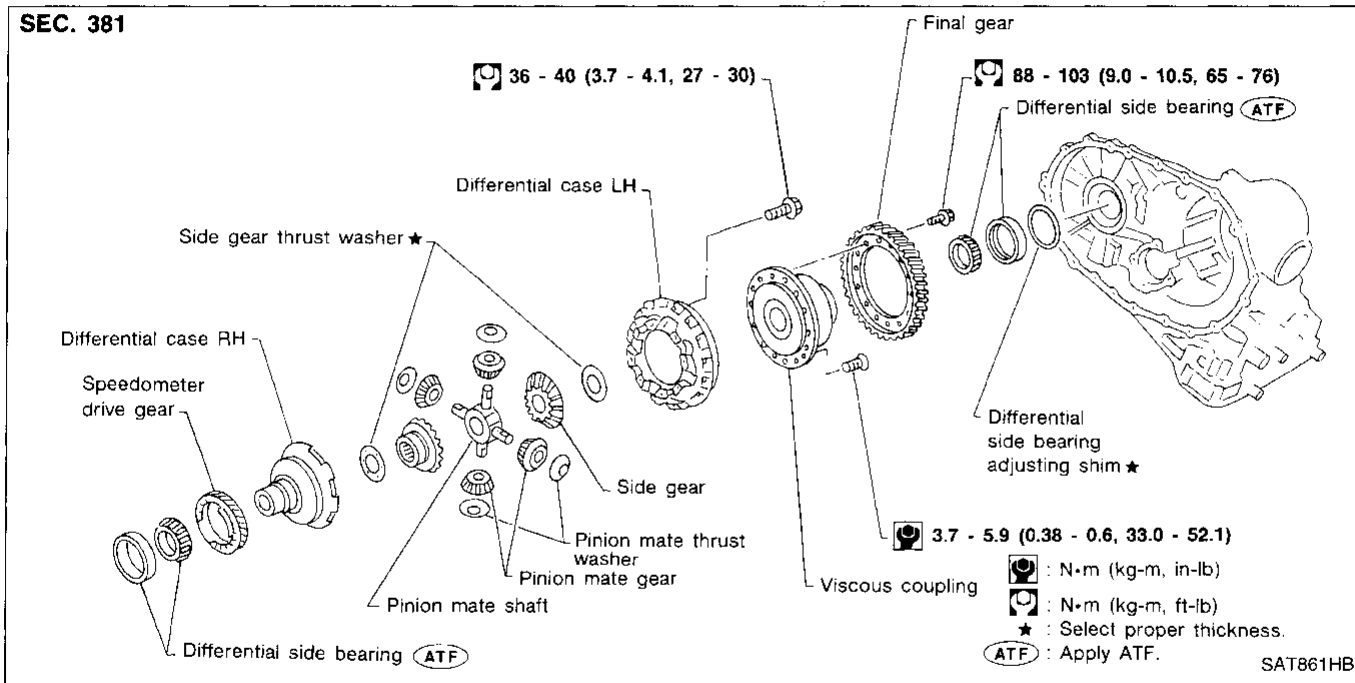

DISASSEMBLY

1. Remove final gear.

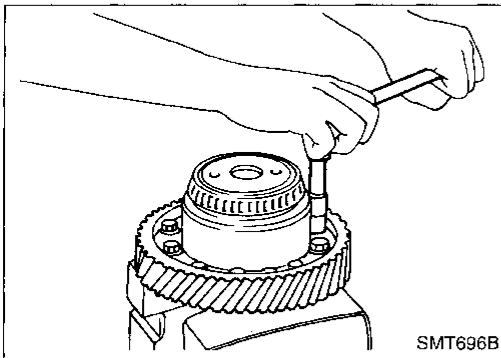

2. Press out differential side bearings.

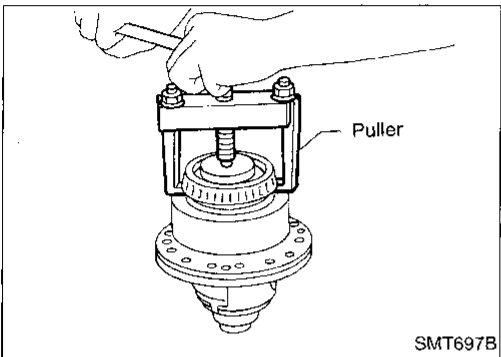

3. Remove differential side bearing outer race, and side bearing adjusting shim from transmission case.

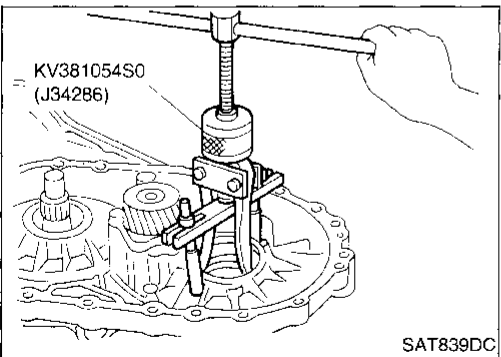



# REPAIR FOR COMPONENT PARTS

## Final Drive — RE4F04V (Cont'd)

4. Remove speedometer drive gear.

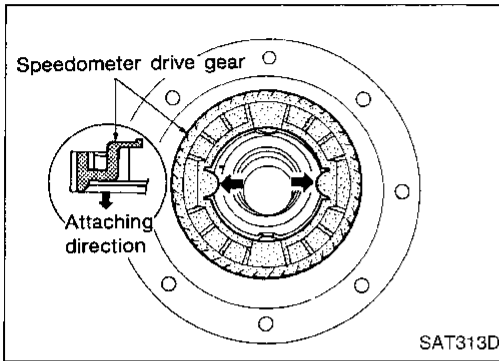

5. Remove viscous coupling.

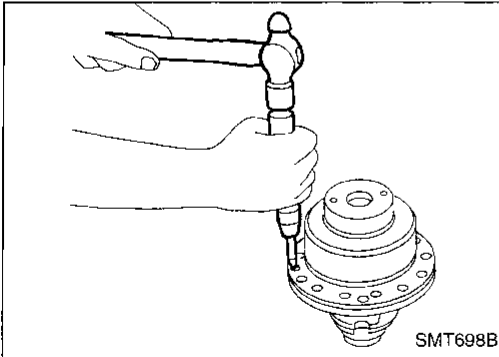

6. Separate differential cases. Make paint marks to identify their original position.

7. Remove pinion mate shaft with gears.

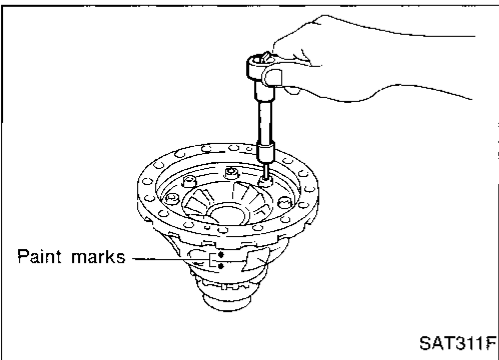

### INSPECTION

#### Gear, washer, shaft and case

- Check mating surfaces of differential case, side gears, pinion mate gears and viscous coupling.
- Check washers for wear.

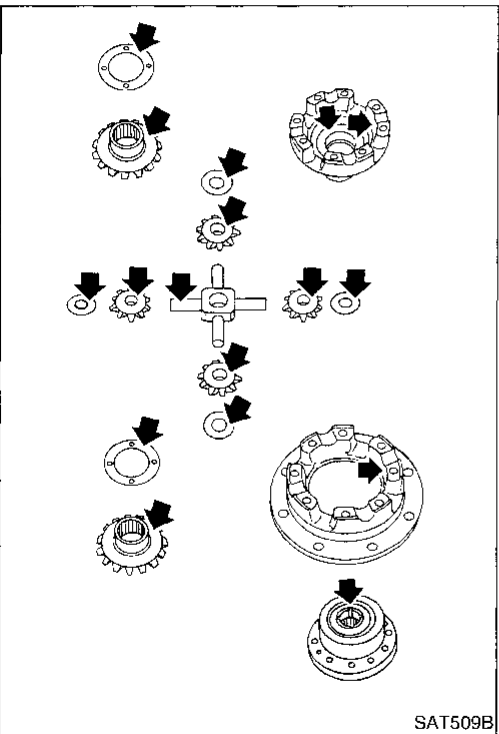

GI

MA

EM

LC

EC

FE

CL

MT

AT

FA

RA

BR

ST

RS

BT

HA

EL

IDX

## REPAIR FOR COMPONENT PARTS

### Final Drive — RE4F04V (Cont'd)

#### Viscous coupling

- Check case for cracks.
- Check silicone oil for leakage.

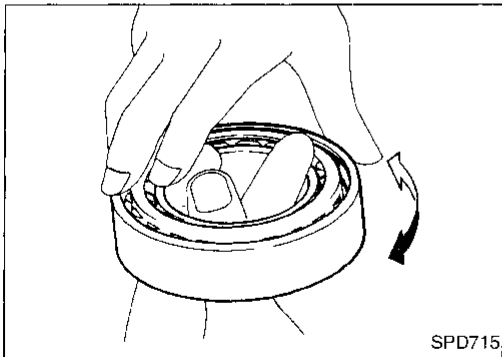
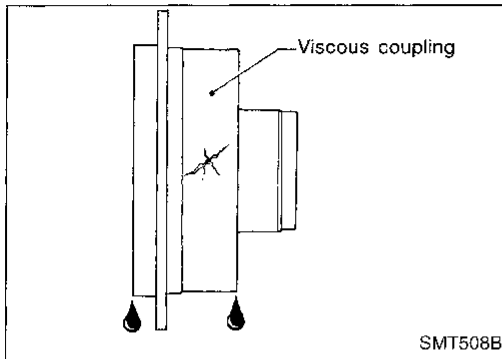

#### Bearings

- Make sure bearings roll freely and are free from noise, cracks, pitting or wear.
- **When replacing taper roller bearing, replace outer and inner race as a set.**

#### ASSEMBLY

1. Measure clearance between side gear and differential case & viscous coupling with washers using the following procedure:

##### Differential case side

- a. Set tool on the differential case and lock gauging cylinder in place with set screw.

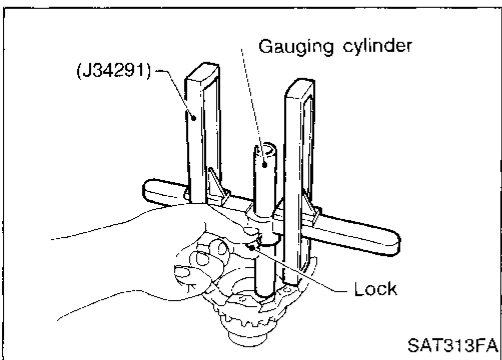

- b. Install gauging plunger into cylinder.
- c. Install pinion mate gears and side gear with thrust washer on differential case.
- d. Set tool and allow gauging plunger to rest on side gear thrust washer.
- e. Measure gap between plunger and cylinder. This measurement should give exact clearance between side gear and differential case with washers.

##### Standard clearance:

**0.1 - 0.2 mm (0.004 - 0.008 in)**

- f. If not within specification adjust clearance by changing thickness of side gear thrust washer.

##### Side gear thrust washers for differential case side:

**Refer to SDS, AT-227.**

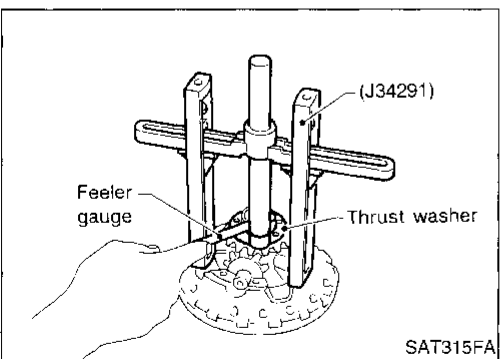
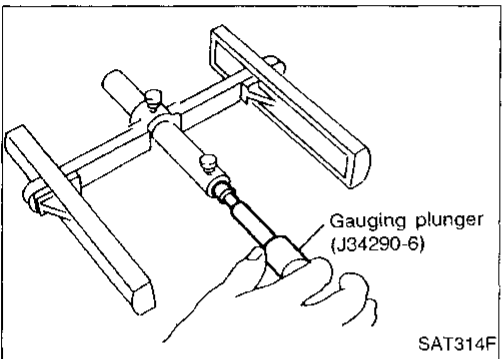

# REPAIR FOR COMPONENT PARTS

## Final Drive — RE4F04V (Cont'd)

### Viscous coupling side

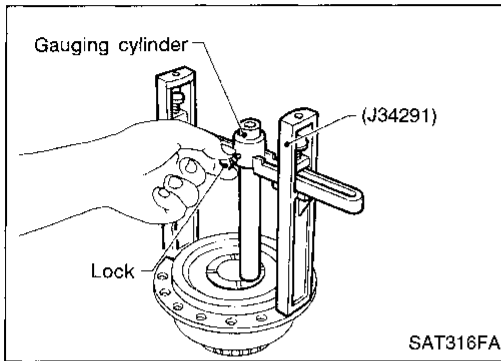

- a. Set tool on viscous coupling and lock gauging cylinder in place with set screw.

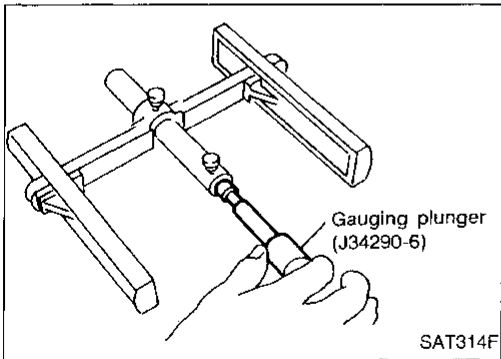

- b. Install gauging plunger into cylinder.

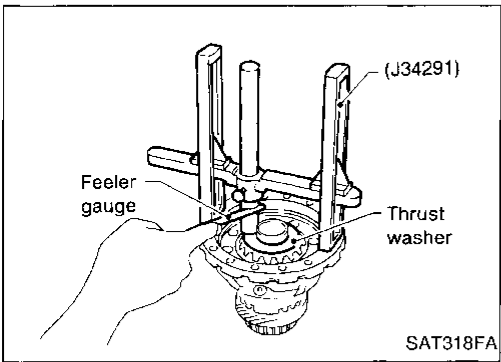

- c. Install pinion mate gears and side gears with original washers on differential cases.

#### Align paint marks.

- d. Tighten differential case bolts.
- e. Set tool and allow plunger to rest on side gear thrust washer.
- f. Measure gap between plunger and cylinder. This measurement should give exact clearance between side gear and differential case with washers.

#### Standard clearance:

**0.1 - 0.2 mm (0.004 - 0.008 in)**

- g. If not within specification, adjust clearance by changing thickness of side gear thrust washer.

**Side gear thrust washers for viscous coupling side:  
Refer to SDS, AT-227.**

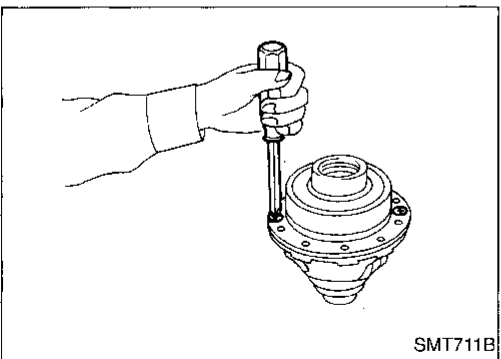

2. Install viscous coupling.

GI

MA

EM

LC

EC

FE

CL

MT

AT

FA

RA

BR

ST

RS

BT

HA

EL

IDX

## REPAIR FOR COMPONENT PARTS

### Final Drive — RE4F04V (Cont'd)

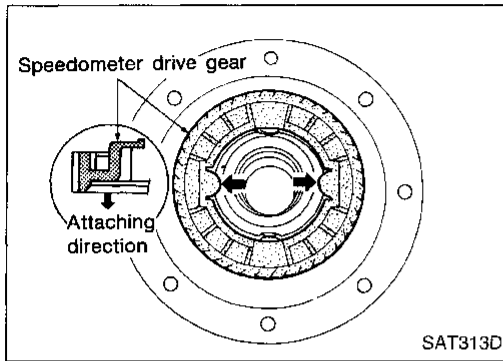

3. Install speedometer drive gear on differential case.
  - **Align the projection of speedometer drive gear with the groove of differential case.**

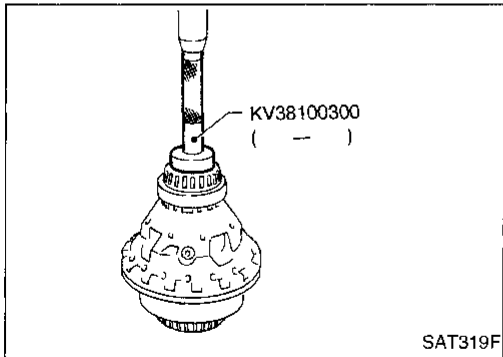

4. Press differential side bearings on differential case.

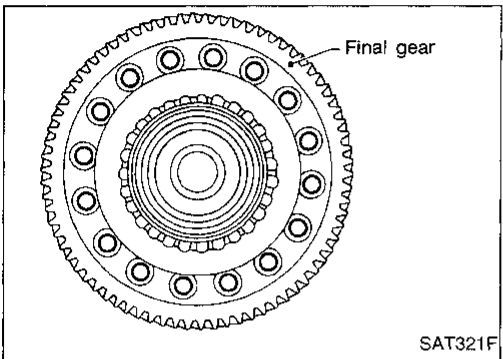
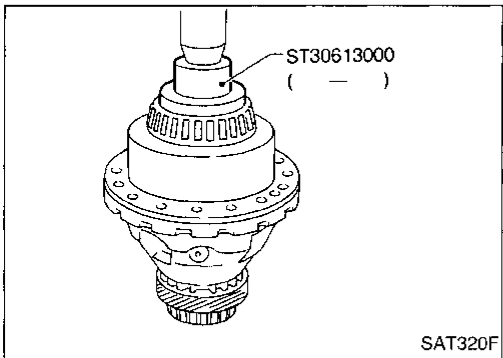

5. Install final gear and tighten fixing bolts in a crisscross pattern.

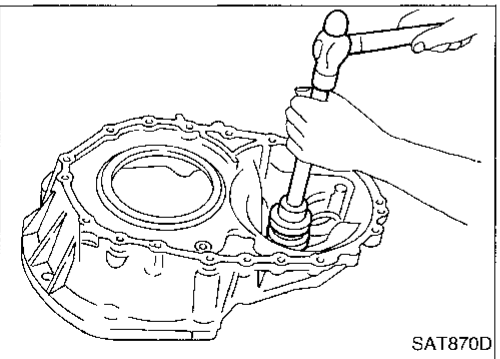
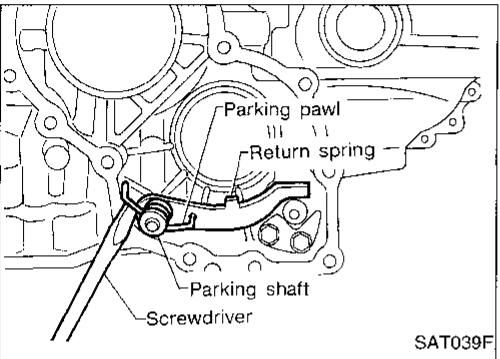
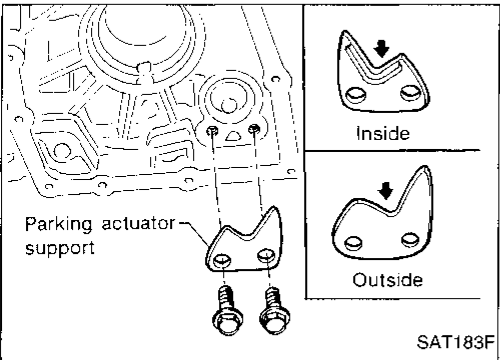
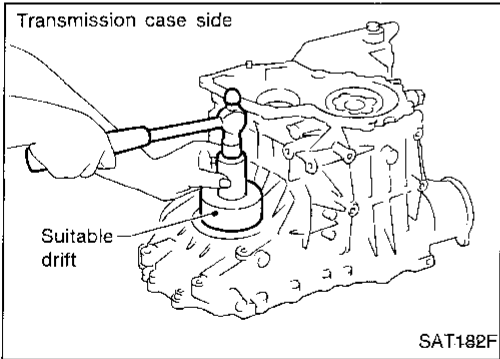
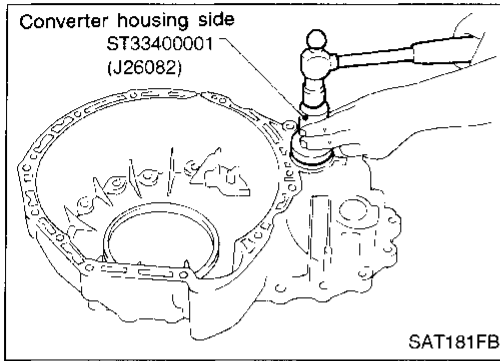

## Assembly 1

1. Install differential side oil seals on transmission case and converter housing.

2. Install parking actuator support to transmission case.

- Pay attention to direction of parking actuator support.

3. Install parking pawl on transmission case and fix it with parking shaft.

4. Install return spring.

## Adjustment 1

### DIFFERENTIAL SIDE BEARING PRELOAD

1. Install differential side bearing outer race without adjusting shim on transmission case.
2. Install differential side bearing outer race on converter housing.

GI

MA

EM

LC

EC

FE

CL

MT

AT

FA

RA

BR

ST

RS

BT

HA

EL

IDX

## ASSEMBLY

### Adjustment 1 (Cont'd)

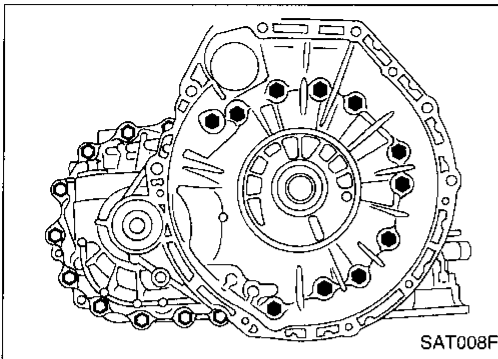

3. Place final drive assembly on transmission case.
4. Install transmission case on converter housing. Tighten transmission case fixing bolts to the specified torque.

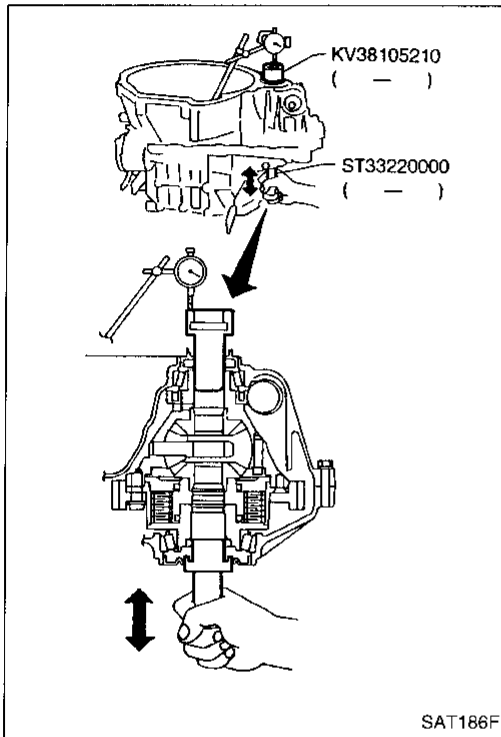

5. Set Tool on differential case at converter housing side and attach dial indicator on Tool.
6. Insert the other Tool viscous coupling from transmission case side.
7. Move Tool up and down and measure dial indicator deflection.
8. Select proper thickness of differential side bearing adjusting shim(s).

**Suitable shim thickness = Dial indicator deflection  
+ Specified bearing preload**

**Differential side bearing adjusting shim:**

**Refer to SDS, AT-227.**

**Bearing preload:**

**0.05 - 0.09 mm (0.0020 - 0.0035 in)**

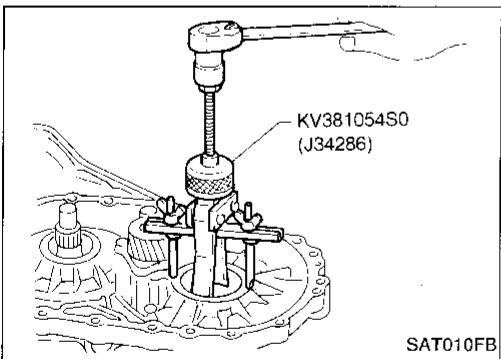

9. Remove converter housing from transmission case.
10. Remove final drive assembly from transmission case.
11. Remove differential side bearing outer race from transmission case.
12. Reinstall differential side bearing outer race and shim(s) selected from SDS table on transmission case.
13. Reinstall converter housing on transmission case and tighten transmission case fixing bolts to the specified torque.

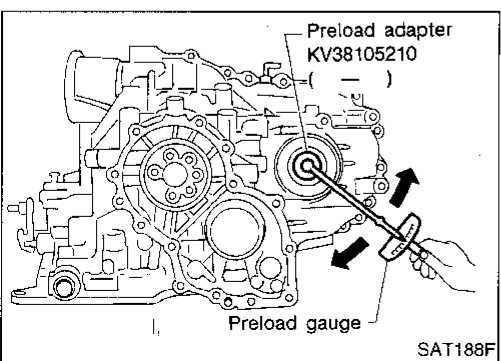

14. Insert Tool into viscous coupling and measure turning torque of final drive assembly.

- **When measuring turning torque, turn final drive assembly in both directions several times to seat bearing rollers correctly.**

**Turning torque of final drive assembly (New bearing):  
0.78 - 1.37 N·m (8.0 - 14.0 kg-cm, 6.9 - 12.2 in-lb)**

- **When old bearing is used again, turning torque will be slightly less than the above.**
- **Make sure torque is close to the specified range.**

# ASSEMBLY

## Adjustment 1 (Cont'd)

### REDUCTION PINION GEAR BEARING PRELOAD

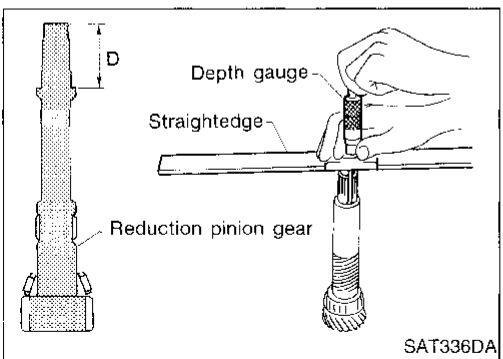
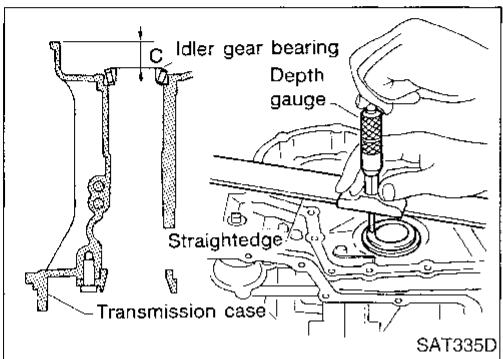
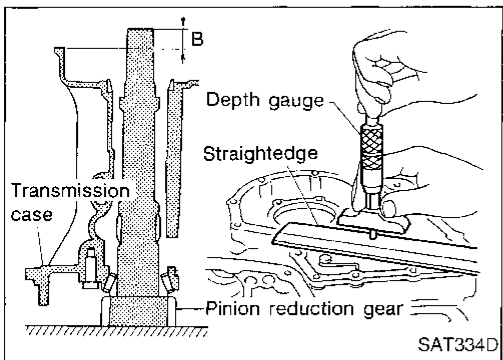
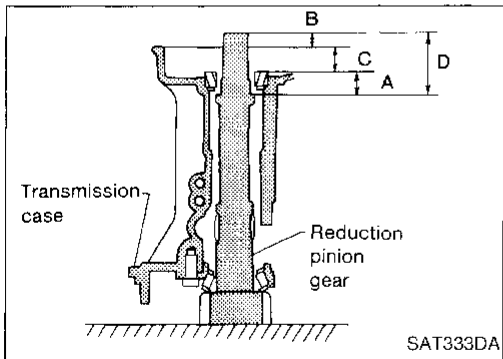
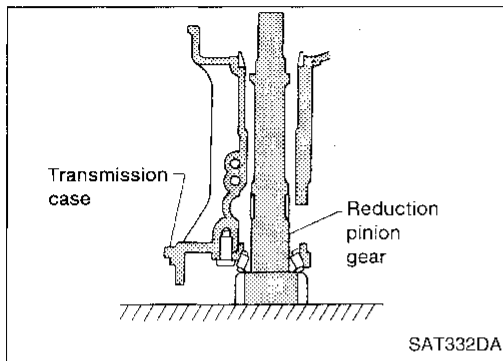

1. Remove transmission case and final drive assembly from converter housing.
2. Select proper thickness of reduction pinion gear bearing adjusting shim using the following procedures.
  - a. Place reduction pinion gear on transmission case as shown.

- b. Place idler gear bearing on transmission case.
- c. Measure dimensions "B" "C" and "D" and calculate dimension "A".

$$A = D - (B + C)$$

"A": Distance between the surface of idler gear bearing inner race and the adjusting shim mating surface of reduction pinion gear.

- Measure dimension "B" between the end of reduction pinion gear and the surface of transmission case.
- Measure dimension "B" in at least two places.

- Measure dimension "C" between the surface of idler gear bearing inner race and the surface of transmission case.
- Measure dimension "C" in at least two places.

- Measure dimension "D" between the end of reduction pinion gear and the adjusting shim mating surface of reduction pinion gear.
- Measure dimension "D" in at least two places.
- Calculate dimension "A".

$$A = D - (B + C)$$

GI

MA

EM

LC

EC

FE

CL

MT

AT

FA

RA

BR

ST

RS

BT

HA

EL

IDX

## ASSEMBLY

### Adjustment 1 (Cont'd)

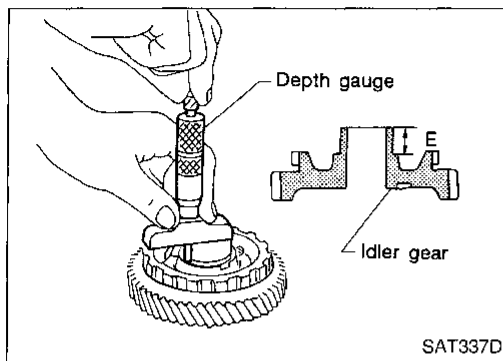

- d. Measure dimension "E" between the end of idler gear and the idler gear bearing inner race mating surface of idler gear.
  - **Measure dimension "E" in at least two places.**

- e. Select proper thickness of reduction pinion gear bearing adjusting shim.

**Proper shim thickness = A - E - 0.5 mm (0.0020 in)\***

(\* ... Bearing preload)

**Reduction pinion gear bearing adjusting shim:**

**Refer to SDS, AT-228.**

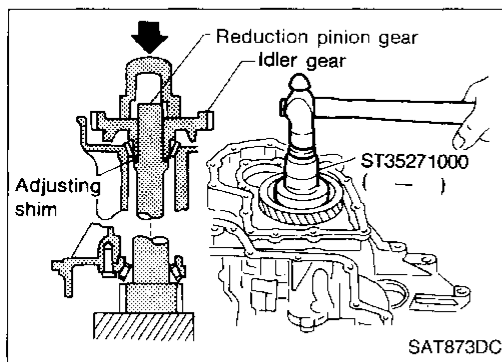

3. Install reduction pinion gear and reduction pinion gear bearing adjusting shim selected in step 2-e on transmission case.
4. Press idler gear bearing inner race on idler gear.
5. Press idler gear on reduction pinion gear.
  - **Press idler gear until idler gear fully contacts adjusting shim.**

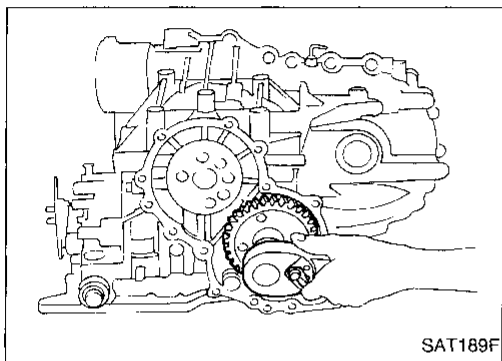

6. Tighten idler gear lock nut to the specified torque.
  - **Lock idler gear with parking pawl when tightening lock nut.**

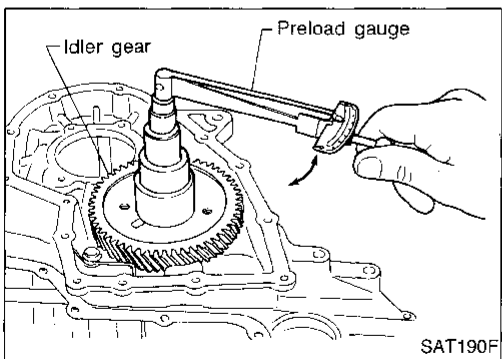

7. Measure turning torque of reduction pinion gear.
  - **When measuring turning torque, turn reduction pinion gear in both directions several times to seat bearing rollers correctly.**

**Turning torque of reduction pinion gear:**  
0.05 - 0.39 N·m (0.5 - 4.0 kg·cm, 0.43 - 3.47 in·lb)
  - **If turning torque is out of specification, decrease or increase thickness of reduction pinion gear bearing adjusting shim.**



# ASSEMBLY

## Adjustment 1 (Cont'd)

- After properly adjusting turning torque, clinch idler gear lock nut as shown.

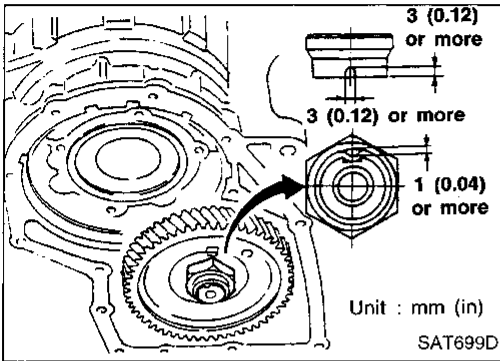

GI

MA

EM

## OUTPUT SHAFT END PLAY

- Measure clearance between side cover and the end of the output shaft bearing.
- Select proper thickness of adjusting shim so that clearance is within specifications.

LC

EC

FE

CL

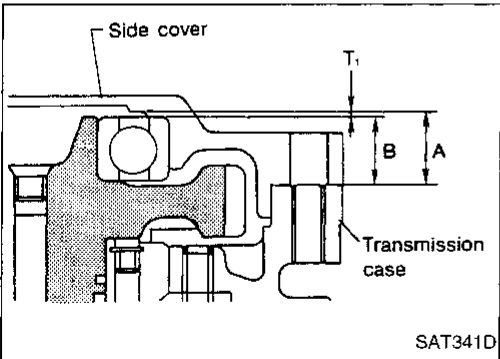

MT

AT

FA

RA

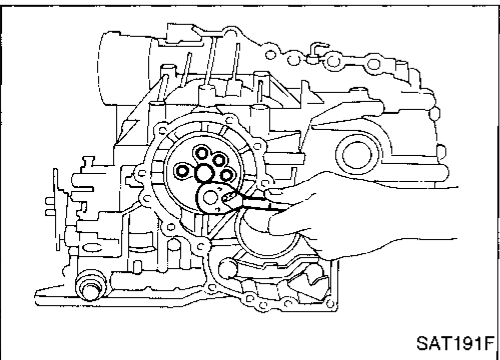

- Install bearing retainer for output shaft.

BR

ST

RS

BT

HA

EL

ICX

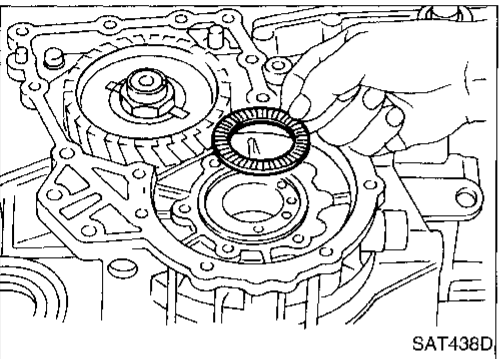

- Install output shaft thrust needle bearing on bearing retainer.

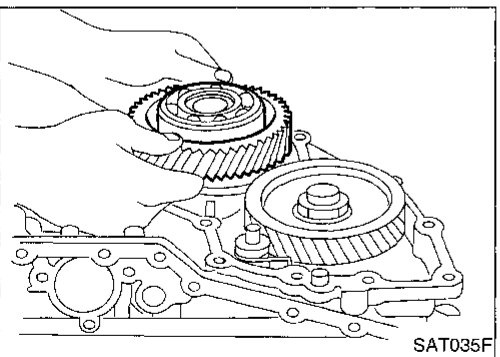

- Install output shaft on transmission case.

## ASSEMBLY

### Adjustment 1 (Cont'd)

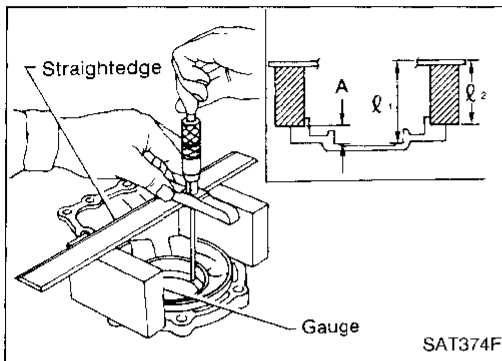

4. Measure dimensions " $l_1$ " and " $l_2$ " at side cover and then calculate dimension "A".

- Measure dimension " $l_1$ " and " $l_2$ " in at least two places.  
 "A": Distance between transmission case fitting surface and adjusting shim mating surface.  
 $A = l_1 - l_2$        $l_2$ : Height of gauge

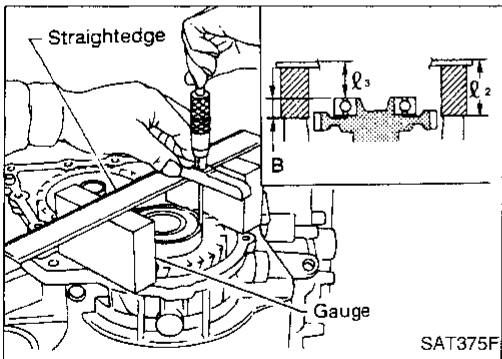

5. Measure dimensions " $l_2$ " and " $l_3$ " and then calculate dimension "B".

- Measure " $l_2$ " and " $l_3$ " in at least two places.  
 "B": Distance between the end of output shaft bearing outer race and the side cover fitting surface of transmission case.  
 $B = l_2 - l_3$        $l_2$ : Height of gauge

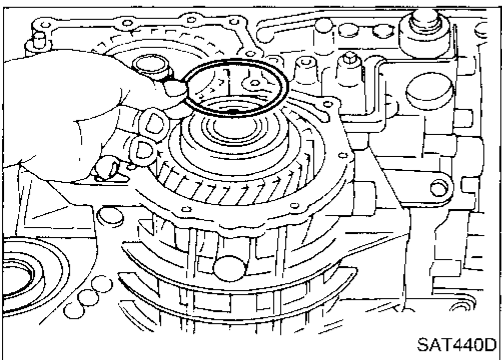

6. Select proper thickness of adjusting shim so that output shaft end play (clearance between side cover and output shaft bearing) is within specifications.

**Output shaft end play (A - B):**  
 0 - 0.15 mm (0 - 0.0059 in)

**Output shaft end play adjusting shim:**  
 Refer to SDS, AT-230.

7. Install adjusting shim on output shaft bearing.

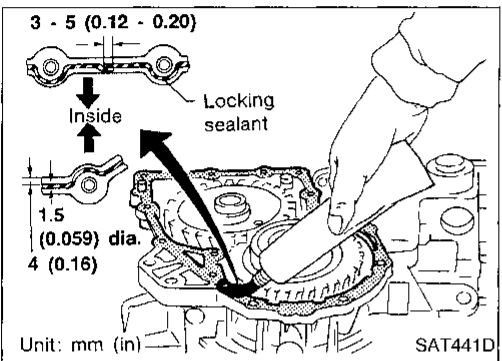

### Assembly 2

1. Apply locking sealant to transmission case as shown in illustration.

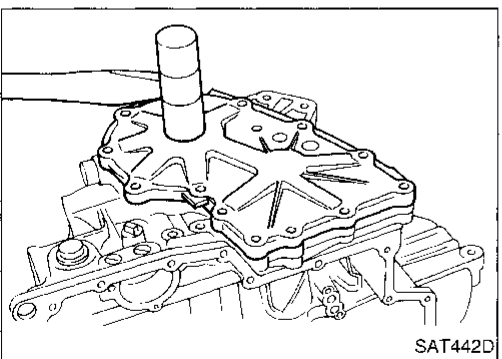

2. Set side cover on transmission case.

- Apply locking sealant to the mating surface of transmission case.

# ASSEMBLY

## Assembly 2 (Cont'd)

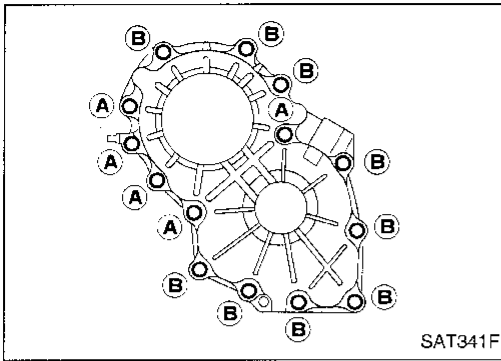

- Tighten side cover fixing bolts to specified torque.
  - Do not mix bolts (A) and (B).
  - Always replace bolts (A) as they are self-sealing bolts.

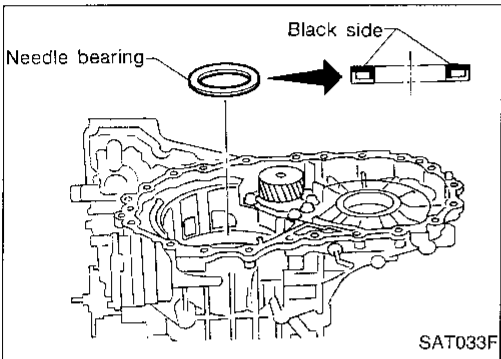

- Remove paper rolled around bearing retainer.
- Install thrust washer on bearing retainer.
  - Apply petroleum jelly to thrust washer.

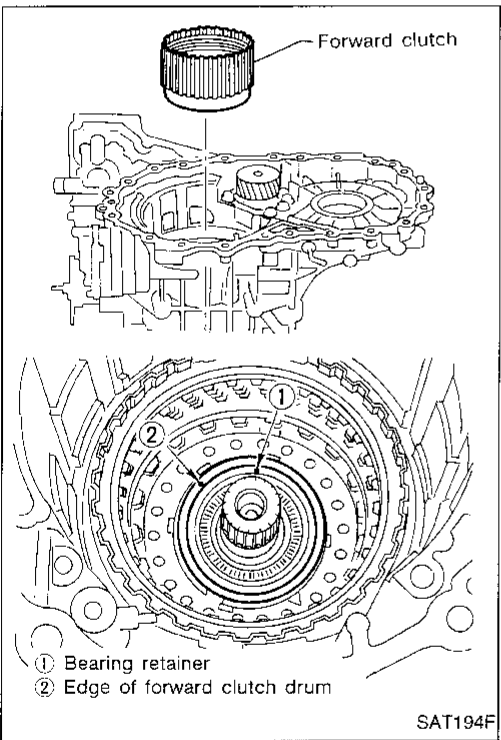

- Install forward clutch assembly.
  - Align teeth of low & reverse brake drive plates before installing.
  - Make sure that bearing retainer seal rings are not spread.
  - If forward clutch assembly is correctly seated, points ① and ② are at almost same level.

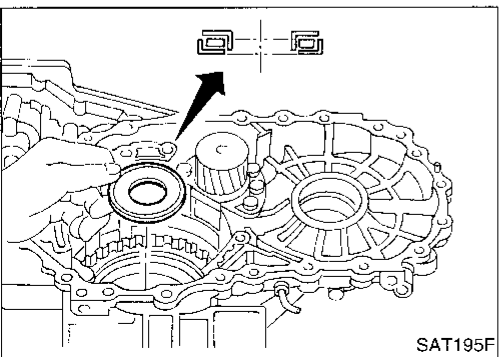

- Install thrust needle bearing on bearing retainer.
  - Apply petroleum jelly to thrust needle bearing.
  - Pay attention to direction of thrust needle bearing.

GI

MA

EM

LC

EC

FE

CL

MT

AT

FA

RA

BR

ST

RS

BT

HA

EL

IDX

## ASSEMBLY

### Assembly 2 (Cont'd)

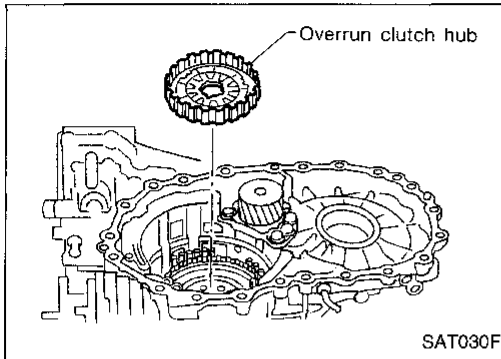

8. Install overrun clutch hub.
  - **Apply petroleum jelly to thrust washers.**
  - **Align teeth of overrun clutch drive plates before installing.**

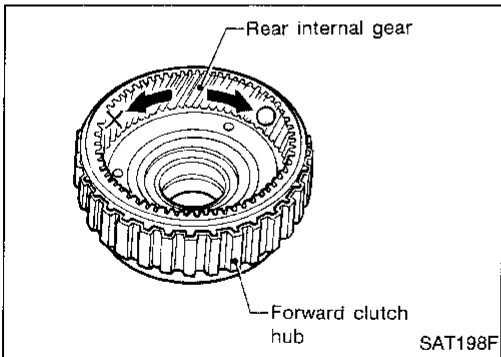

9. Hold forward clutch hub and turn rear internal gear. Check overrun clutch hub for correct directions of lock and unlock.
  - **If not shown as illustration, check installed direction of forward one-way clutch.**

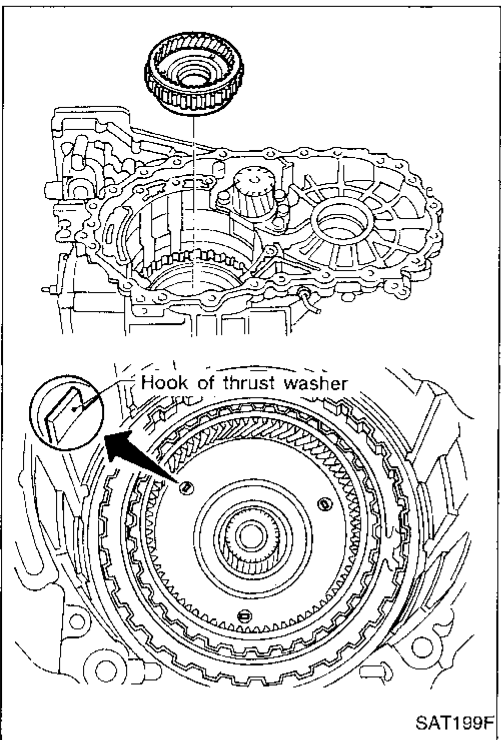

10. Install forward clutch hub and rear internal gear assembly.
  - **Align teeth of forward clutch drive plates before installing.**
  - **Check three hooks of thrust washer are correctly aligned after installing.**

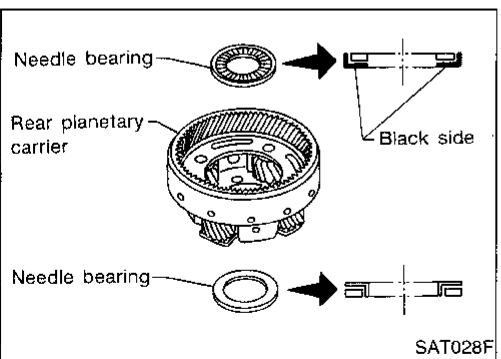

11. Install rear planetary carrier assembly and rear sun gear according to the following procedures.
  - a. Install needle bearings on rear planetary carrier.
    - **Apply petroleum jelly to needle bearings.**
    - **Pay attention to direction of needle bearings.**

# ASSEMBLY

## Assembly 2 (Cont'd)

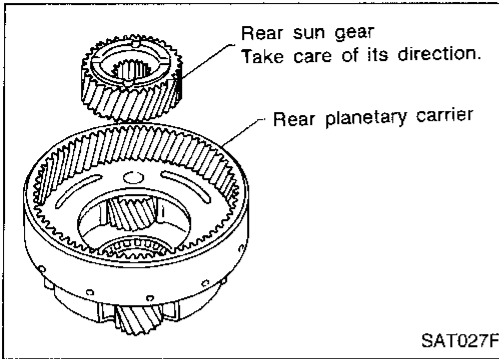

- b. Install rear sun gear on rear planetary carrier.
- Pay attention to direction of rear sun gear.

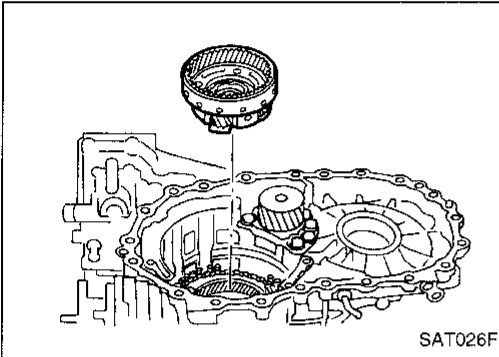

- c. Install rear planetary carrier on transmission case.

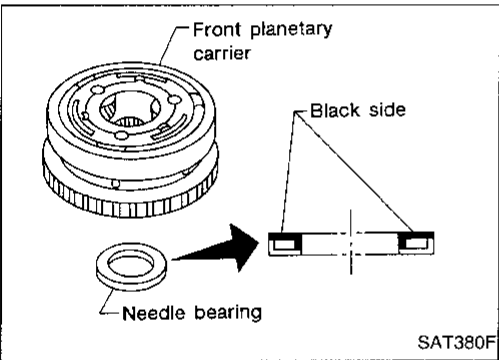

12. Install thrust needle bearing on front planetary carrier, then install them together on transmission case.
- Apply petroleum jelly to thrust needle bearing.
  - Pay attention to direction of thrust needle bearing.

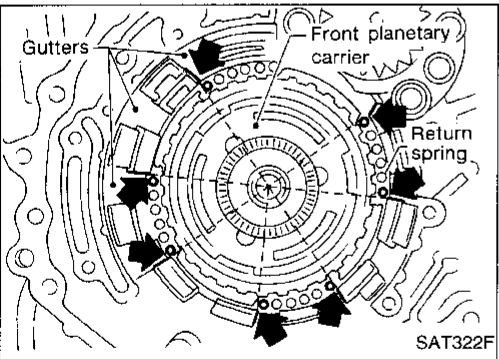

13. Install low and reverse brake piston according to the following procedures.
- a. Set and align return springs to transmission case gutters as shown in illustration.

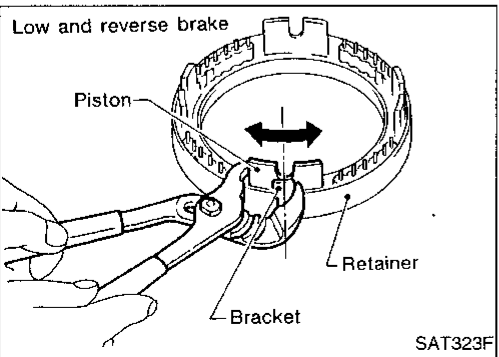

- b. Set and align piston with retainer.

GI

MA

EM

LC

EC

FE

CL

MT

AT

FA

RA

BR

ST

RS

BT

HA

EL

IDX

## ASSEMBLY

### Assembly 2 (Cont'd)

- c. Install piston and retainer assembly on the transmission case.
- **Align bracket to specified gutter as indicated in illustration.**

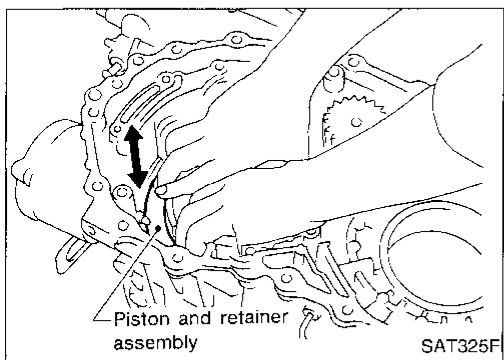
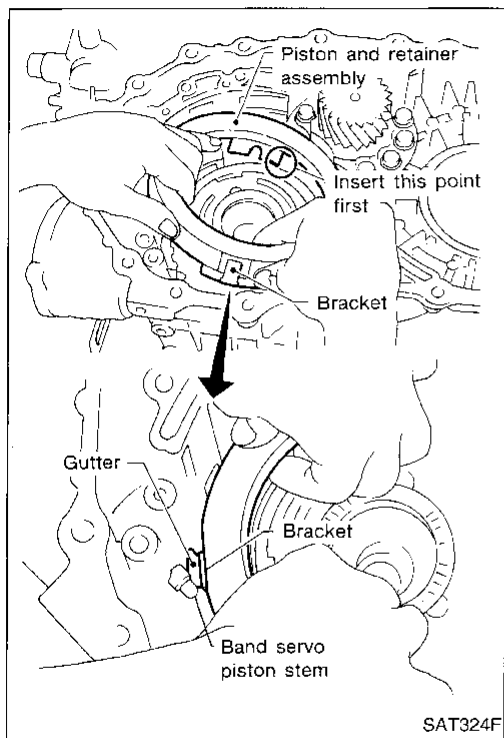

- d. Check that each protrusions of piston is correctly set to corresponding return spring as follows.

**Push piston and retainer assembly evenly and confirm they move smoothly.**

**If they can not move smoothly, remove piston and retainer assembly and align return spring correctly as instructed in step "a".**

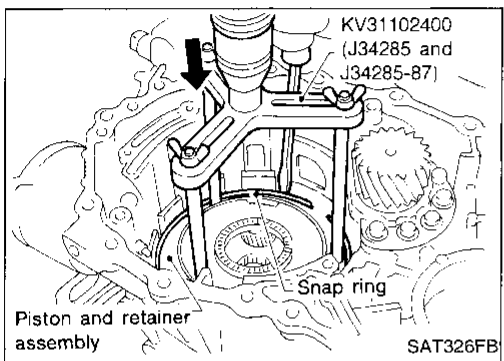

- e. Push down piston and retainer assembly and install snap ring.

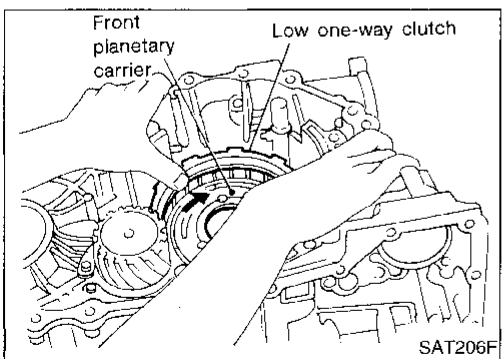

14. Install low one-way clutch to front planetary carrier by turning carrier in the direction of the arrow shown.

# ASSEMBLY

## Assembly 2 (Cont'd)

15. Install snap ring with screwdriver.

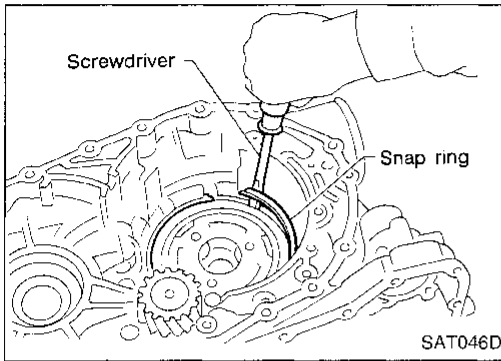

16. Install needle bearing on transmission case.

- Apply petroleum jelly to needle bearing.
- Pay attention to direction of needle bearing.

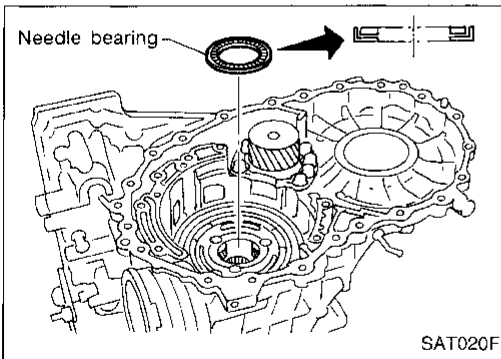

17. Install bearing race, needle bearing and high clutch hub on front sun gear.

- Apply petroleum jelly to needle bearing.
- Pay attention to direction of needle bearing.

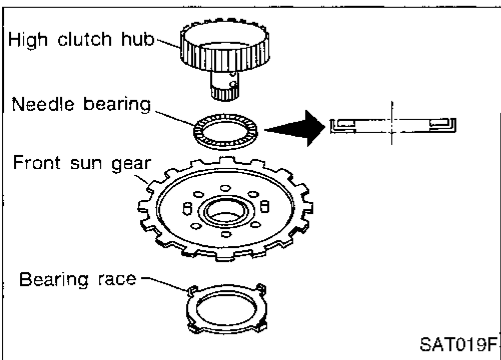

18. Install needle bearing and high clutch drum on high clutch hub.

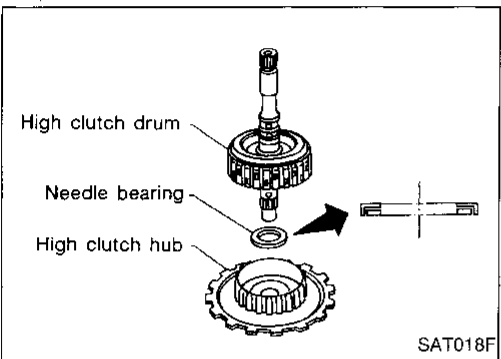

19. Install needle bearing on high clutch drum.

- Apply petroleum jelly to needle bearing.
- Pay attention to direction of needle bearing.

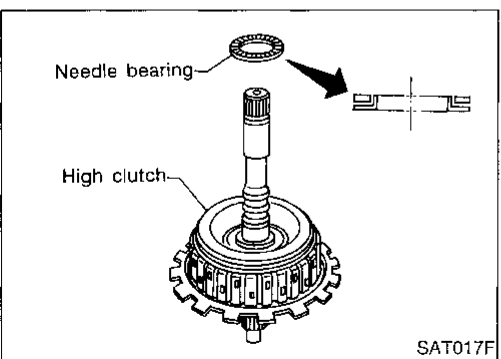

GI

MA

EM

LC

EC

FE

CL

MT

AT

FA

RA

BR

ST

RS

BT

HA

EL

IDX

## ASSEMBLY

### Assembly 2 (Cont'd)

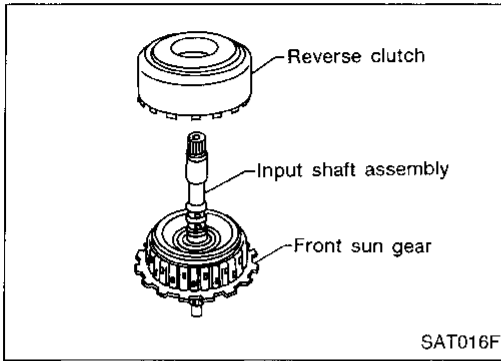

20. Remove paper rolled around input shaft.

21. Install input shaft assembly in reverse clutch.

- **Align teeth of reverse clutch drive plates before installing.**

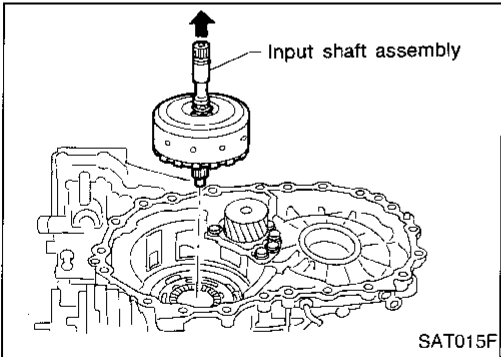

22. Install reverse clutch assembly on transmission case.

- **Align teeth of high clutch drive plates before installing.**

### Adjustment 2

When any parts listed in the following table are replaced, total end play or reverse clutch end play must be adjusted.

Part name	Total end play	Reverse clutch end play
Transmission case	•	•
Overrun clutch hub	•	•
Rear internal gear	•	•
Rear planetary carrier	•	•
Rear sun gear	•	•
Front planetary carrier	•	•
Front sun gear	•	•
High clutch hub	•	•
High clutch drum	•	•
Oil pump cover	•	•
Reverse clutch drum	—	•

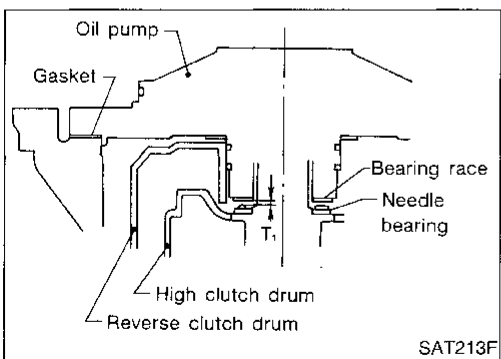

### TOTAL END PLAY

1. Adjust total end play "T<sub>1</sub>".



# ASSEMBLY

## Adjustment 2 (Cont'd)

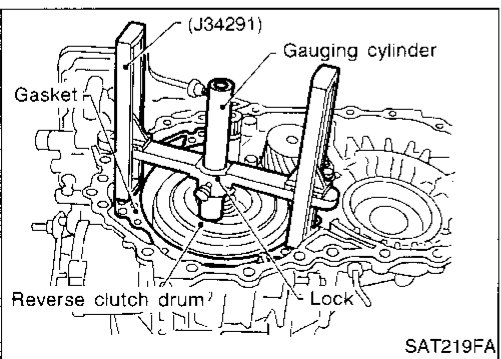
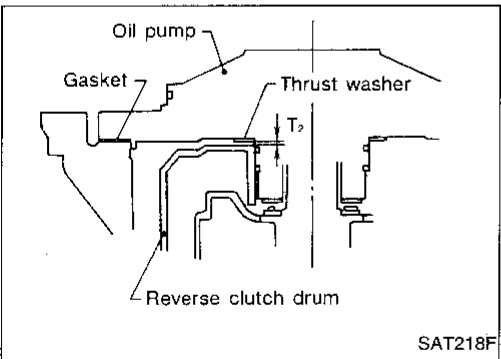
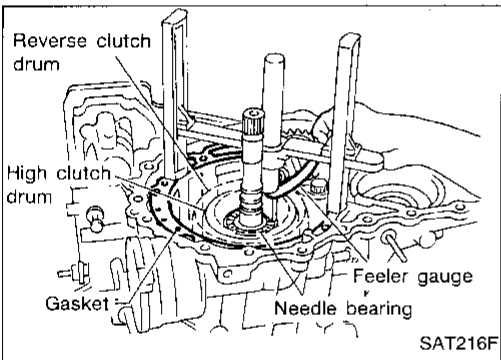
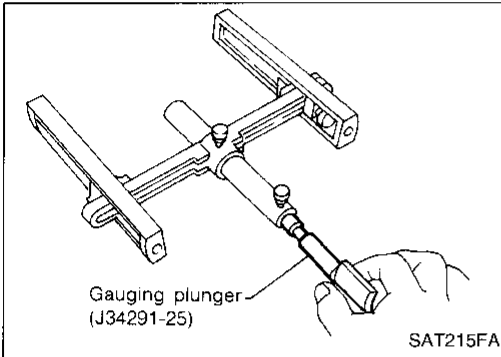
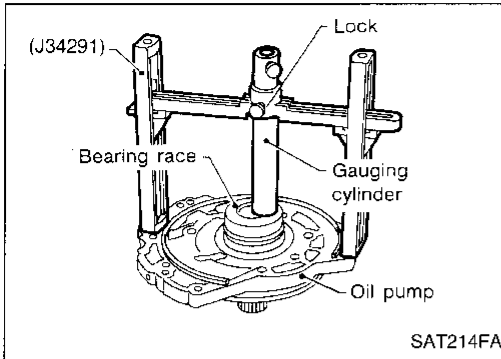

a. With original bearing race installed, place Tool onto oil pump. The long ends of legs should be placed firmly on machined surface of oil pump assembly. The gauging cylinder should rest on top of bearing race. Lock gauging cylinder in place with set screw.

b. Install gauging plunger into cylinder.

c. With needle bearing installed on high clutch drum, place Tool legs on machined surface of transmission case (with gasket). Then allow plunger to rest on needle bearing.

d. Measure gap between cylinder and plunger. This measurement should give exact total end play.

**Total end play "T<sub>1</sub>":**

**0.25 - 0.55 mm (0.0098 - 0.0217 in)**

• If end play is out of specification, decrease or increase thickness of bearing race as necessary.

**Available bearing race:**

**Refer to SDS, AT-230.**

2. Adjust reverse clutch drum end play "T<sub>2</sub>".

a. Place Tool on machined surface of transmission case (with gasket). Then allow gauging cylinder to rest on reverse clutch drum. Lock cylinder in place with set screw.

GI

MA

EM

LC

EC

FE

CL

MT

AT

FA

RA

BR

ST

RS

BT

HA

EL

IDX

## ASSEMBLY

### Adjustment 2 (Cont'd)

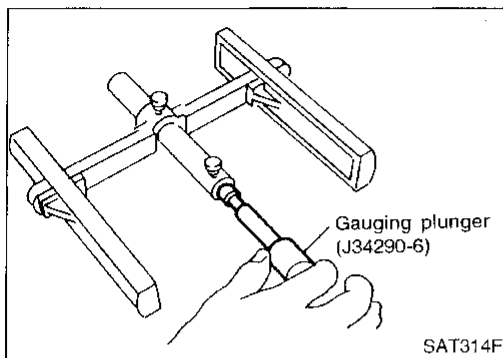

- b. Install gauging plunger into cylinder.
- c. With original thrust washer installed on oil pump, place Tool legs onto machined surface of oil pump assembly. Then allow plunger to rest on thrust washer.
- d. Measure gap between cylinder and plunger with feeler gauge. This measurement should give exact reverse clutch drum end play.

#### Reverse clutch drum end play "T<sub>2</sub>":

0.55 - 0.90 mm (0.0217 - 0.0354 in)

- If end play is out of specification, decrease or increase thickness of thrust washer as necessary.

#### Available thrust washer:

Refer to SDS, AT-229.

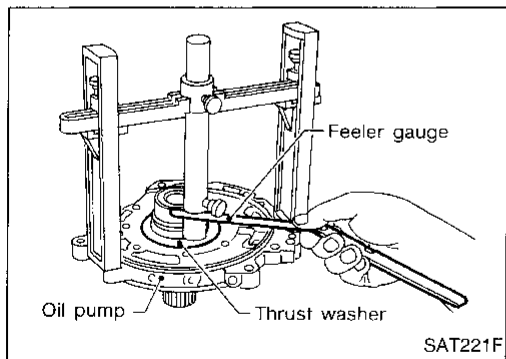

### Assembly 3

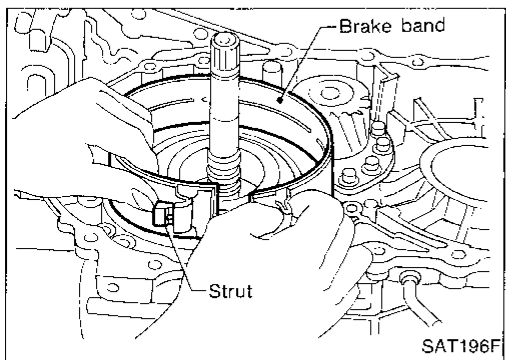

1. Install anchor end pin and lock nut on transmission case.
2. Place brake band and strut on periphery of reverse clutch drum. Then, tighten anchor end pin just enough so that brake band is fitted on periphery of reverse clutch drum uniformly.

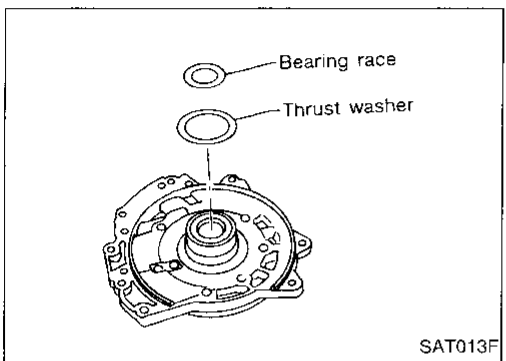

3. Place bearing race selected in total end play adjustment step on oil pump cover.

- **Apply petroleum jelly to bearing race.**
- 4. Place thrust washer selected in reverse clutch end play step on reverse clutch drum.
- **Apply petroleum jelly to thrust washer.**

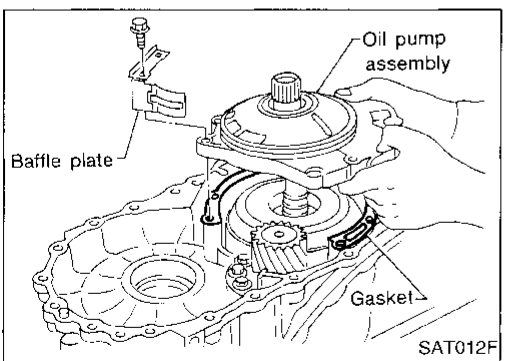

5. Install oil pump assembly, baffle plate and gasket on transmission case.
6. Tighten oil pump fixing bolts to the specified torque.

# ASSEMBLY

## Assembly 3 (Cont'd)

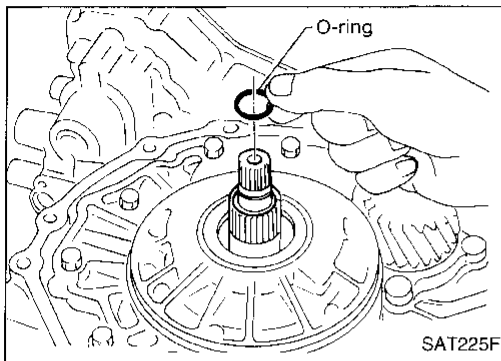

7. Install O-ring to input shaft.
  - Apply ATF to O-ring.

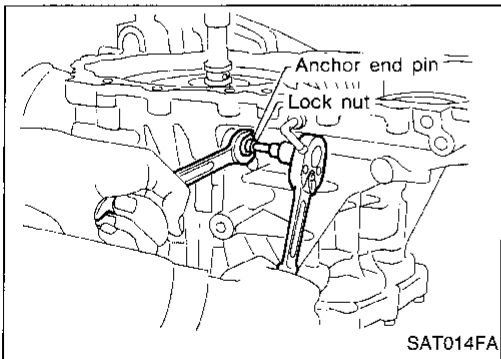

8. Adjust brake band.
  - a. Tighten anchor end pin to the specified torque.

**Anchor end pin:**  
☞ : 3.9 - 5.9 N·m (0.4 - 0.6 kg-m, 35 - 52 in-lb)
  - b. Back off anchor end pin two and a half turns.
  - c. While holding anchor end pin, tighten lock nut.

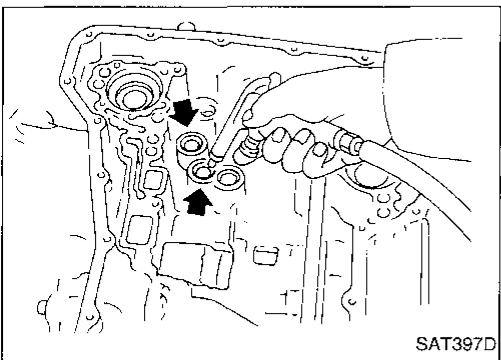

9. Apply compressed air to oil holes of transmission case and check operation of brake band.

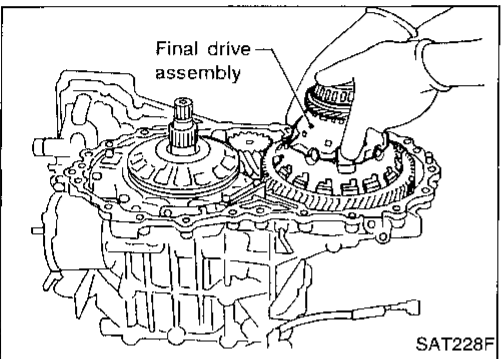

10. Install final drive assembly on transmission case.

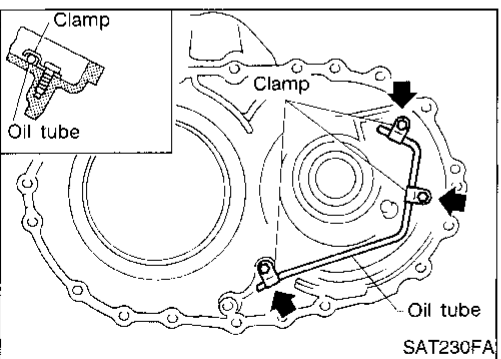

11. Install oil tube on converter housing.

GI

MA

EM

LC

EC

FE

CL

MT

AT

FA

RA

BR

ST

RS

BT

HA

EL

IDX

# ASSEMBLY

## Assembly 3 (Cont'd)

12. Install O-ring on differential oil port of transmission case.

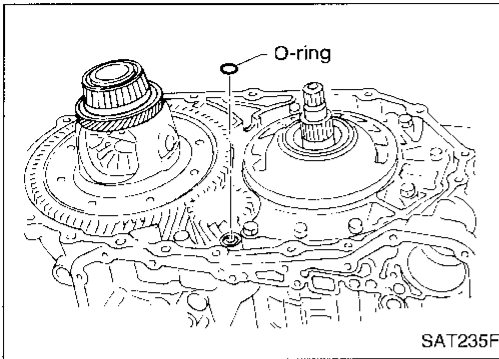

13. Install converter housing on transmission case.

- Apply locking sealant to mating surface of converter housing.

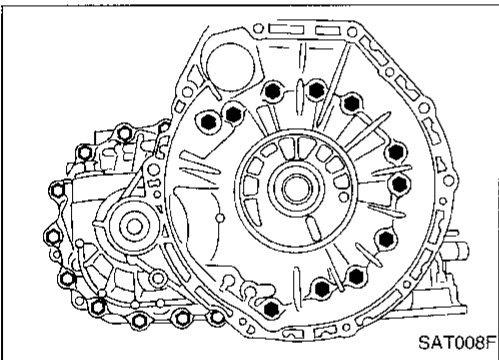
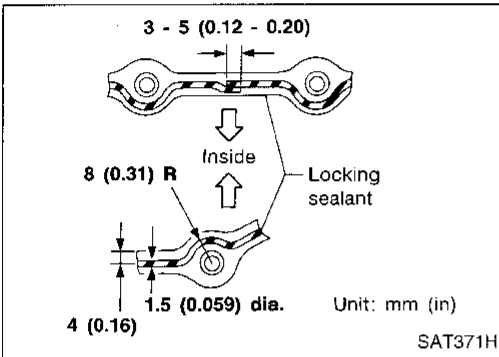

14. Install accumulator piston.

- a. Check contact surface of accumulator piston for damage.

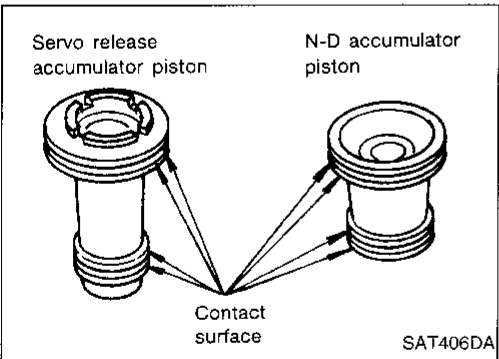

- b. Install O-rings on accumulator piston.

- Apply ATF to O-rings.  
**Accumulator piston O-rings:  
Refer to SDS, AT-229.**

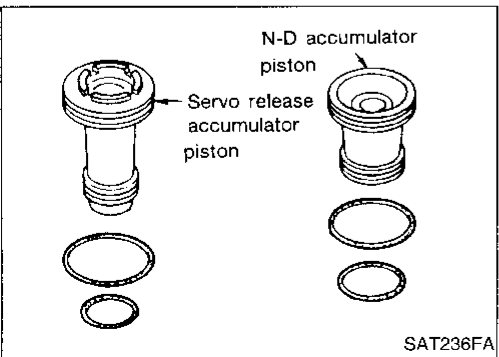

# ASSEMBLY

## Assembly 3 (Cont'd)

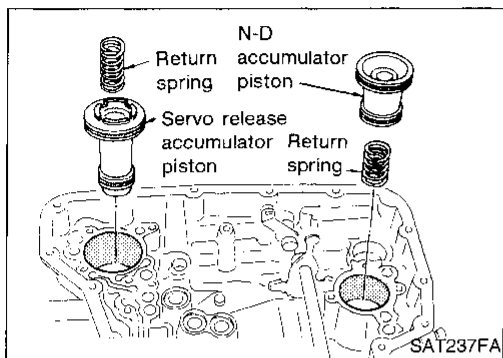

c. Install accumulator pistons and return springs on transmission case.

- **Apply ATF to inner surface of transmission case.**  
**Return springs:**  
**Refer to SDS, AT-229.**

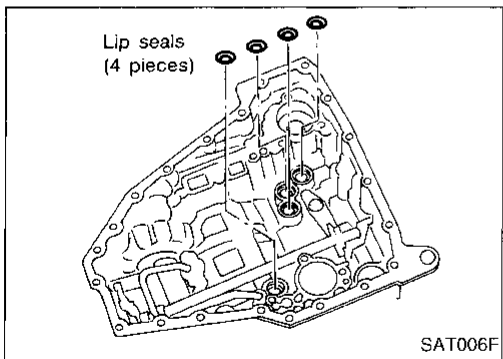

15. Install lip seals for band servo oil holes on transmission case.

- **Apply petroleum jelly to lip seals.**

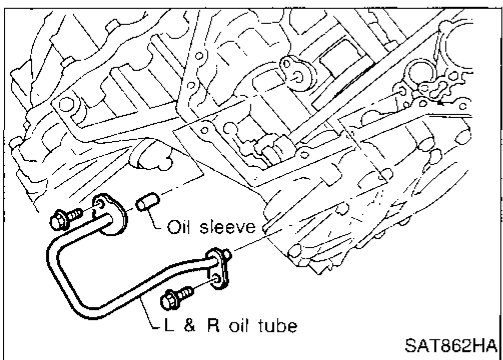

16. Install L & R oil tube and oil sleeve.

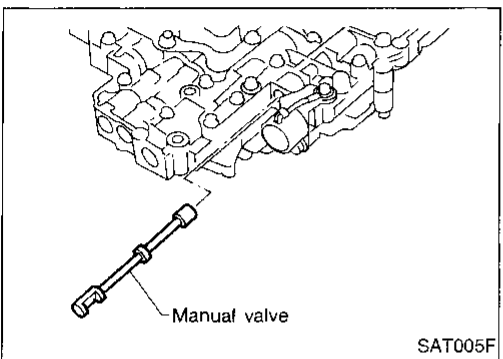

17. Install control valve assembly.

- a. Insert manual valve into control valve assembly.
- **Apply ATF to manual valve.**

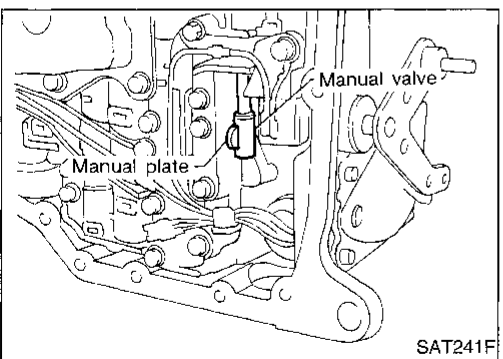

b. Set manual shaft in Neutral position.

c. Install control valve assembly on transmission case while aligning manual valve with manual plate.

GE

MA

EM

LC

EC

FE

CL

MT

AT

FA

RA

BR

ST

RS

BT

HA

EL

IDX

# ASSEMBLY

## Assembly 3 (Cont'd)

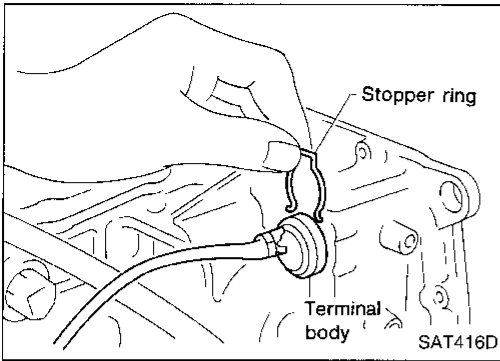

- d. Pass solenoid harness through transmission case and install terminal body on transmission case by pushing it.
- e. Install stopper ring to terminal body.

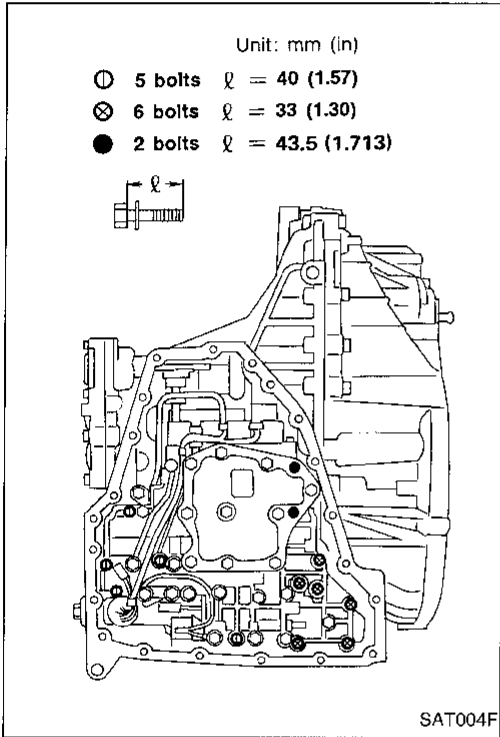

- f. Tighten bolts ①, ⊗ and ●.

### Bolt length, number and location:

Bolt	①	⊗	●
Bolt length "ℓ"  mm (in)	40.0 (1.575)	33.0 (1.299)	43.5 (1.713)
Number of bolts	5	6	2

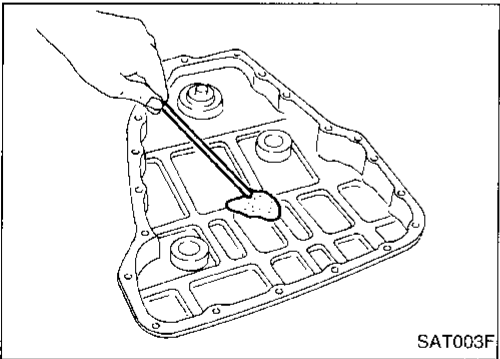

18. Install oil pan.

- a. Attach a magnet to oil pan.
- b. Install new oil pan gasket on transmission case.
- c. Install oil pan on transmission case.
  - **Always replace oil pan bolts as they are self-sealing bolts.**
  - **Tighten four bolts in a criss-cross pattern to prevent dislocation of gasket.**
- d. Tighten drain plug to the specified torque.

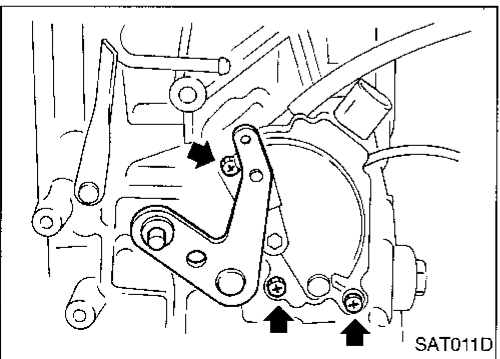

19. Install inhibitor switch.

- a. Set manual shaft in "P" position.
- b. Temporarily install inhibitor switch on manual shaft.
- c. Move selector lever to "N" position.

# ASSEMBLY

## Assembly 3 (Cont'd)

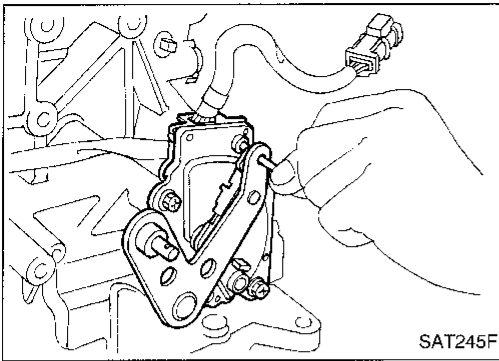

- d. Insert 4.0 mm (0.157 in) dia. pin into adjustment hole in both inhibitor switch and manual shaft as near vertically as possible.
- e. Tighten inhibitor switch fixing bolts.
- f. Remove pin from adjustment hole after adjusting inhibitor switch.

GI

VA

EM

LC

EC

FE

CL

MT

AT

FA

RA

BR

ST

RS

BT

HA

EL

IDX

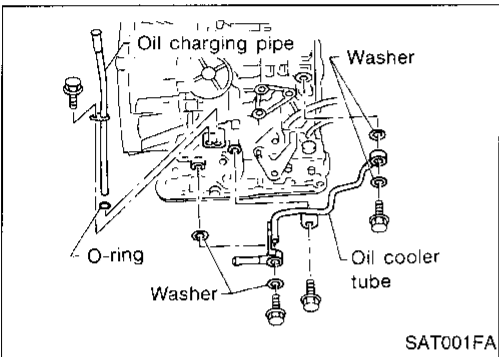

20. Install oil charging pipe and oil cooler tube to transmission case.

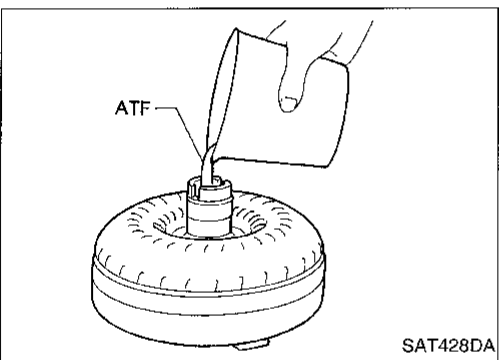

21. Install torque converter.
  - a. Pour ATF into torque converter.
    - **Approximately 1 liters (1-1/8 US qt, 7/8 Imp qt) of fluid are required for a new torque converter.**
    - **When reusing old torque converter, add the same amount of fluid as was drained.**

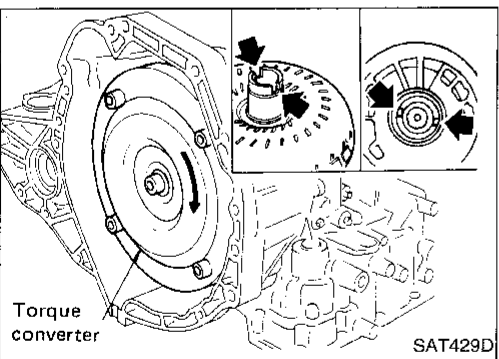

- b. Install torque converter while aligning notches of torque converter with notches of oil pump.

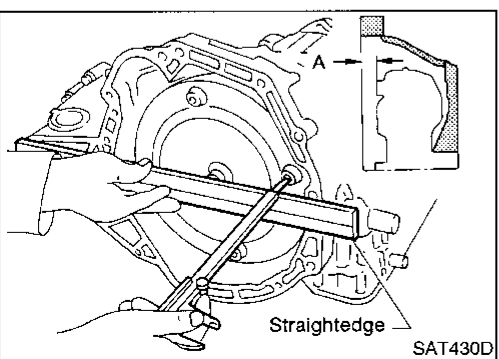

- c. Measure distance "A" to check that torque converter is in proper position.
      - Distance "A": 14 mm (0.55 in) or more**

# SERVICE DATA AND SPECIFICATIONS (SDS)

## General Specifications

Engine	VQ30DE	
Automatic transaxle model	RE4F04A	RE4F04V
Automatic transaxle assembly		
Model code number	80X17	80X18
Transaxle gear ratio		
1st	2.785	
2nd	1.545	
3rd	1.000	
4th	0.694	
Reverse	2.272	
Final drive	3.619	
Recommended oil	Nissan Matic "D" (Continental U.S. and Alaska) or Genuine Nissan Automatic Transmission Fluid (Canada)*1	
Oil capacity	l (US qt, Imp qt)	9.4 (10, 8-1/4)

\*1: Refer to MA section ("Fluids and Lubricants", "RECOMMENDED FLUIDS AND LUBRICANTS").

## Specifications and Adjustments

### VEHICLE SPEED WHEN SHIFTING GEARS

Throttle position	Shift pattern	Vehicle speed km/h (MPH)						
		D <sub>1</sub> → D <sub>2</sub>	D <sub>2</sub> → D <sub>3</sub>	D <sub>3</sub> → D <sub>4</sub>	D <sub>4</sub> → D <sub>3</sub>	D <sub>3</sub> → D <sub>2</sub>	D <sub>2</sub> → D <sub>1</sub>	1 <sub>2</sub> → 1 <sub>1</sub>
Full throttle	Comfort	61 - 69 (38 - 43)	113 - 121 (70 - 75)	177 - 185 (110 - 115)	173 - 181 (108 - 112)	103 - 111 (64 - 69)	54 - 62 (34 - 39)	61 - 69 (38 - 43)
	Auto power	61 - 69 (38 - 43)	113 - 121 (70 - 75)	177 - 185 (110 - 115)	173 - 181 (108 - 112)	103 - 111 (64 - 69)	54 - 62 (34 - 39)	61 - 69 (38 - 43)
Half throttle	Comfort	39 - 47 (24 - 29)	73 - 81 (45 - 50)	113 - 121 (70 - 75)	79 - 87 (49 - 54)	36 - 44 (22 - 27)	5 - 13 (3 - 8)	61 - 69 (38 - 43)
	Auto power	46 - 54 (29 - 34)	85 - 93 (53 - 58)	134 - 142 (83 - 88)	85 - 93 (53 - 58)	51 - 59 (32 - 37)	5 - 13 (3 - 8)	61 - 69 (38 - 43)

### VEHICLE SPEED WHEN PERFORMING LOCK-UP (Reference value)

Model code No.	80X17		80X18
Vehicle speed	km/h (MPH)	Throttle position 1/8	49 - 65 (30 - 40)

- Note:
- Lock-up vehicle speed indicates the speed in D<sub>4</sub> position.
  - Make sure that lock-up is released under the following conditions:
    - Throttle opening 0/8
    - Vehicle speed is less than 120 km/h (75 MPH).
  - Perform lock-up inspection after warming up engine.
  - Lock-up vehicle speed may vary depending on the driving conditions and circumstances.

### STALL REVOLUTION

Engine	Stall revolution rpm
VQ30DE	2,000 - 2,300

### LINE PRESSURE

Engine speed rpm	Line pressure kPa (kg/cm <sup>2</sup> , psi)	
	D, 2 and 1 positions	R position
Idle	500 (5.1, 73)	853 (8.7, 124)
Stall	1,098 (11.2, 159)	1,863 (19.0, 270)



# SERVICE DATA AND SPECIFICATIONS (SDS)

## Specifications and Adjustments (Cont'd)

### CONTROL VALVES

#### Control valve and plug return springs

Unit: mm (in)

	Parts		Item			
			Part No.	Free length	Outer diameter	
Upper body	⑩	Pilot valve spring	31742-80X14	36.0 (1.417)	8.1 (0.319)	GI
	⑧	1-2 accumulator valve spring	31742-80X10	20.5 (0.807)	7.0 (0.276)	MA
	⑫	1-2 accumulator piston spring	31742-80X19	49.3 (1.941)	19.6 (0.772)	
	⑮	1st reducing valve spring	31742-80X05	27.0 (1.063)	7.0 (0.276)	EM
	⑯	Overrun clutch reducing valve spring	31742-80X15	37.5 (1.476)	6.9 (0.272)	
	⑪	Torque converter relief valve spring	31742-80X07	31.0 (1.220)	9.0 (0.354)	LC
	④	Lock-up control valve	31742-80X17	39.5 (1.555)	11.0 (0.433)	
Lower body	⑭	Pressure regulator valve spring	31742-80X13	45.0 (1.772)	15.0 (0.591)	EC
	⑮	Overrun clutch control valve spring	31762-80X00	21.7 (0.854)	7.0 (0.276)	
	⑰	Accumulator control valve spring	31742-80X02	22.0 (0.866)	6.5 (0.256)	FE
	⑱	Shift valve A spring	31762-80X00	21.7 (0.854)	7.0 (0.276)	
	⑲	Shift valve B spring	31762-80X00	21.7 (0.854)	7.0 (0.276)	
	③	Pressure modifier valve spring	31742-41X15	30.5 (1.201)	9.8 (0.386)	CL
	⑦		31742-80X16	32.0 (1.260)	6.9 (0.272)	
	⑰	Plug spring	31742-80X11	17.0 (0.669)	10.7 (0.421)	MT

AT

FA

RA

BR

ST

RS

BT

HA

EL

IDX

# SERVICE DATA AND SPECIFICATIONS (SDS)

## Specifications and Adjustments (Cont'd)

### CLUTCHES AND BRAKES

Reverse clutch		
Number of drive plates	2	
Number of driven plates	2	
Drive plate thickness	mm (in)	
Standard	1.6 (0.063)	
Allowable limit	1.4 (0.055)	
Clearance	mm (in)	
Standard	0.5 - 0.8 (0.020 - 0.031)	
Allowable limit	1.2 (0.047)	
Thickness of retaining plates	Thickness mm (in)	Part number
	6.6 (0.260)	31537-80X05
	6.8 (0.268)	31537-80X06
	7.0 (0.276)	31537-80X07
	7.2 (0.283)	31537-80X08
	7.4 (0.291)	31537-80X09
	7.6 (0.299)	31537-80X20
	7.8 (0.307)	31537-80X21
High clutch		
Number of drive plates	4	
Number of driven plates	6 + 1	
Drive plate thickness	mm (in)	
Standard	1.6 (0.063)	
Allowable limit	1.4 (0.055)	
Clearance	mm (in)	
Standard	1.8 - 2.2 (0.071 - 0.087)	
Allowable limit	3.0 (0.118)	
Thickness of retaining plates	Thickness mm (in)	Part number
	3.0 (0.118)	31537-81X10
	3.2 (0.126)	31537-81X11
	3.4 (0.134)	31537-81X12
	3.6 (0.142)	31537-81X13
	3.8 (0.150)	31537-81X14
Forward clutch		
Number of drive plates	5	
Number of driven plates	5	
Drive plate thickness	mm (in)	
Standard	1.6 (0.063)	
Allowable limit	1.4 (0.055)	
Clearance	mm (in)	
Standard	0.45 - 0.85 (0.0177 - 0.0335)	
Allowable limit	1.85 (0.0728)	
Thickness of retaining plates	Thickness mm (in)	Part number
	3.6 (0.142)	31537-80X70
	3.8 (0.150)	31537-80X71
	4.0 (0.157)	31537-80X72
	4.2 (0.165)	31537-80X73
	4.4 (0.173)	31537-80X74
	3.4 (0.134)	31537-80X75
	3.2 (0.126)	31537-80X76

Overrun clutch		
Number of drive plates	3	
Number of driven plates	5	
Drive plate thickness	mm (in)	
Standard	1.6 (0.063)	
Allowable limit	1.4 (0.055)	
Clearance	mm (in)	
Standard	0.7 - 1.1 (0.028 - 0.043)	
Allowable limit	1.7 (0.067)	
Thickness of retaining plates	Thickness mm (in)	Part number
	3.0 (0.118)	31537-80X65
	3.2 (0.126)	31537-80X66
	3.4 (0.134)	31537-80X67
	3.6 (0.142)	31537-80X68
	3.8 (0.150)	31537-80X69
Low & reverse brake		
Number of drive plates	7	
Number of driven plates	8	
Drive plate thickness	mm (in)	
Standard	1.8 (0.071)	
Allowable limit	1.6 (0.063)	
Clearance	mm (in)	
Standard	1.7 - 2.1 (0.067 - 0.083)	
Allowable limit	3.5 (0.138)	
Thickness of retaining plates	Thickness mm (in)	Part number
	2.0 (0.079)	31667-80X00
	2.2 (0.087)	31667-80X01
	2.4 (0.094)	31667-80X02
	2.6 (0.102)	31667-80X03
	2.8 (0.110)	31667-80X04
	3.0 (0.118)	31667-80X05
	3.2 (0.126)	31667-80X06
	3.4 (0.134)	31667-80X07
Brake band		
Anchor end pin tightening torque	3.9 - 5.9 (0.4 - 0.6, 35 - 52)	
N-m (kg-m, in-lb)		
Number of returning revolutions for anchor end pin	2.5	
Lock nut tightening torque	31 - 36 (3.2 - 3.7, 23 - 27)	
N-m (kg-m, ft-lb)		

# SERVICE DATA AND SPECIFICATIONS (SDS)

## Specifications and Adjustments (Cont'd)

### FINAL DRIVE

#### Differential side gear clearance

Clearance between side gear and differential case with washer mm (in)	0.1 - 0.2 (0.004 - 0.008)
--------------------------------------------------------------------------	---------------------------

#### Differential side gear thrust washers

##### RE4F04A

Thickness mm (in)	Part number
0.75 (0.0295)	38424-81X00
0.80 (0.0315)	38424-81X01
0.85 (0.0335)	38424-81X02
0.90 (0.0354)	38424-81X03
0.95 (0.0374)	38424-81X04

##### RE4F04V

Thickness mm (in)		Part number
Viscous coupling side	0.43 - 0.45 (0.0169 - 0.0177)	38424-51E10
	0.52 - 0.54 (0.0205 - 0.0213)	38424-51E11
	0.61 - 0.63 (0.0240 - 0.0248)	38424-51E12
	0.70 - 0.72 (0.0276 - 0.0283)	38424-51E13
	0.79 - 0.81 (0.0311 - 0.0319)	38424-51E14
Differential case side	0.75 - 0.80 (0.0295 - 0.0315)	38424-E3000
	0.80 - 0.85 (0.0315 - 0.0335)	38424-E3001
	0.85 - 0.90 (0.0335 - 0.0354)	38424-E3002
	0.90 - 0.95 (0.0354 - 0.0374)	38424-E3003

### Differential side bearing preload adjusting shims

##### RE4F04A

Thickness mm (in)	Part number
0.48 (0.0189)	31438-80X00
0.52 (0.0205)	31438-80X01
0.56 (0.0220)	31438-80X02
0.60 (0.0236)	31438-80X03
0.64 (0.0252)	31438-80X04
0.68 (0.0268)	31438-80X05
0.72 (0.0283)	31438-80X06
0.76 (0.0299)	31438-80X07
0.80 (0.0315)	31438-80X08
0.84 (0.0331)	31438-80X09
0.88 (0.0346)	31438-80X10
0.92 (0.0362)	31438-80X11

##### RE4F04V

Thickness mm (in)	Part number
0.36 (0.0142)	38753-56E00
0.40 (0.0157)	38753-56E01
0.44 (0.0173)	38753-56E02
0.48 (0.0189)	38753-56E03
0.52 (0.0205)	38753-56E04
0.56 (0.0220)	38753-56E05
0.60 (0.0236)	38753-56E06
0.64 (0.0252)	38753-56E07
0.68 (0.0268)	38753-56E08
0.72 (0.0283)	38753-56E09
0.76 (0.0299)	38753-56E10
0.80 (0.0315)	38753-56E11
0.84 (0.0331)	38753-56E12
0.88 (0.0346)	38753-56E13
0.92 (0.0362)	38753-56E14
0.12 (0.0047)	38753-56E15
0.16 (0.0063)	38753-56E16
0.20 (0.0079)	38753-56E17
0.24 (0.0094)	38753-56E18
0.28 (0.0110)	38753-56E19
0.32 (0.0126)	38753-56E20

GI

MA

EM

LC

EC

FE

CL

MT

AT

FA

RA

BR

ST

RS

BT

HA

EL

IDX

# SERVICE DATA AND SPECIFICATIONS (SDS)

## Specifications and Adjustments (Cont'd)

### Bearing preload

Differential side bearing preload mm (in)	0.05 - 0.09 (0.0020 - 0.0035)
----------------------------------------------	-------------------------------

### Turning torque

Turning torque of final drive assembly N·m (kg·cm, in·lb)	0.78 - 1.37 (8.0 - 14.0, 6.9 - 12.2)
--------------------------------------------------------------	--------------------------------------

### Clutch and brake return springs

Unit: mm (in)

Parts	Free length	Outer diameter
Forward clutch (Overrun clutch) (22 pcs)	21.4 (0.843)	10.3 (0.406)
High clutch (12 pcs)	22.5 (0.886)	10.8 (0.425)

### PLANETARY CARRIER AND OIL PUMP

Planetary carrier Clearance between planetary carrier and pinion washer mm (in)	Standard	0.20 - 0.70 (0.0079 - 0.0276)	
	Allowable limit	0.80 (0.0315)	
Oil pump Oil pump side clearance mm (in)	0.030 - 0.050 (0.0012 - 0.0020)		
	Thickness of inner gears and outer gears	Inner gear	
Thickness mm (in)		Part number	
11.99 - 12.0 (0.4720 - 0.4724)		31346-80X00	
11.98 - 11.99 (0.4717 - 0.4720)		31346-80X01	
11.97 - 11.98 (0.4713 - 0.4717)		31346-80X02	
Outer gear			
Thickness mm (in)		Part number	
11.99 - 12.0 (0.4720 - 0.4724)		31347-80X00	
11.98 - 11.99 (0.4717 - 0.4720)		31347-80X01	
11.97 - 11.98 (0.4713 - 0.4717)		31347-80X02	
Clearance between oil pump housing and outer gear mm (in)	Standard	0.111 - 0.181 (0.0044 - 0.0071)	
	Allowable limit	0.181 (0.0071)	
Oil pump cover seal ring clearance mm (in)	Standard	0.1 - 0.25 (0.0039 - 0.0098)	
	Allowable limit	0.25 (0.0098)	

### INPUT SHAFT

Input shaft seal ring clearance mm (in)	
Standard	0.08 - 0.23 (0.0031 - 0.0091)
Allowable limit	0.23 (0.0091)

### REDUCTION PINION GEAR

#### Turning torque

Turning torque of reduction pinion gear N·m (kg·cm, in·lb)	0.05 - 0.39 (0.5 - 4.0, 0.43 - 3.47)
---------------------------------------------------------------	-----------------------------------------

### Reduction pinion gear bearing adjusting shims

Thickness mm (in)	Part number
5.10 (0.2008)	31439-81X05
5.12 (0.2016)	31439-81X06
5.14 (0.2024)	31439-81X07
5.16 (0.2031)	31439-81X08
5.18 (0.2039)	31439-81X09
5.20 (0.2047)	31439-81X10
5.22 (0.2055)	31439-81X11
5.24 (0.2063)	31439-81X12
5.26 (0.2071)	31439-81X13
5.28 (0.2079)	31439-81X14
5.30 (0.2087)	31439-81X15
5.32 (0.2094)	31439-81X16
5.34 (0.2102)	31439-81X17
5.36 (0.2110)	31439-81X18
5.38 (0.2118)	31439-81X19
5.40 (0.2126)	31439-81X20
5.42 (0.2134)	31439-81X21
5.44 (0.2142)	31439-81X22
5.46 (0.2150)	31439-81X23
5.48 (0.2157)	31439-81X24
5.50 (0.2165)	31439-81X46
5.52 (0.2173)	31439-81X47
5.54 (0.2181)	31439-81X48
5.56 (0.2189)	31439-81X49
5.58 (0.2197)	31439-81X60
5.60 (0.2205)	31439-81X61
5.62 (0.2213)	31439-81X62
5.64 (0.2220)	31439-81X63
5.66 (0.2228)	31439-81X64
5.68 (0.2236)	31439-81X65
5.70 (0.2244)	31439-81X66
5.72 (0.2252)	31439-81X67
5.74 (0.2260)	31439-81X68
5.76 (0.2268)	31439-81X69
5.78 (0.2276)	31439-81X70
5.80 (0.2283)	31439-81X71
5.82 (0.2291)	31439-81X72
5.84 (0.2299)	31439-81X73
5.86 (0.2307)	31439-81X74
5.88 (0.2315)	31439-81X75
5.90 (0.2323)	31439-81X76
5.92 (0.2331)	31439-81X77
5.94 (0.2339)	31439-81X78
5.96 (0.2346)	31439-81X79

# SERVICE DATA AND SPECIFICATIONS (SDS)

## Specifications and Adjustments (Cont'd)

5.98 (0.2354)	31439-81X80
6.00 (0.2362)	31439-81X81
6.02 (0.2370)	31439-81X82
6.04 (0.2378)	31439-81X83
6.06 (0.2386)	31439-81X84
6.08 (0.2394)	31439-82X00
6.10 (0.2402)	31439-82X01
6.12 (0.2409)	31439-82X02
6.14 (0.2417)	31439-82X03
6.16 (0.2425)	31439-82X04
6.18 (0.2433)	31439-82X05
6.20 (0.2441)	31439-82X06
6.22 (0.2449)	31439-82X07
6.24 (0.2457)	31439-82X08
6.26 (0.2465)	31439-82X09
6.28 (0.2472)	31439-82X10
6.30 (0.2480)	31439-82X11
6.32 (0.2488)	31439-82X12
6.34 (0.2496)	31439-82X13
6.36 (0.2504)	31439-82X14
6.38 (0.2512)	31439-82X15
6.40 (0.2520)	31439-82X16
6.42 (0.2528)	31439-82X17
6.44 (0.2535)	31439-82X18
6.46 (0.2543)	31439-82X19
6.48 (0.2551)	31439-82X20
6.50 (0.2559)	31439-82X21
6.52 (0.2567)	31439-82X22
6.54 (0.2575)	31439-82X23
6.56 (0.2583)	31439-82X24
6.58 (0.2591)	31439-82X60
6.60 (0.2598)	31439-82X61

### REVERSE CLUTCH END PLAY

Reverse clutch end play mm (in)	0.55 - 0.90 (0.0217 - 0.0354)
------------------------------------	-------------------------------

### Thrust washers for adjusting reverse clutch drum end play

Thickness mm (in)	Part number
0.80 (0.0315)	31508-80X00
1.40 (0.0551)	31508-80X03
0.95 (0.0374)	31508-80X07
1.10 (0.0433)	31508-80X08
1.25 (0.0492)	31508-80X09
1.55 (0.0610)	31508-80X10
1.70 (0.0669)	31508-80X11
1.85 (0.0728)	31508-80X12

### ACCUMULATOR

#### O-ring

Unit: mm (in)

Accumulator	Inner diameter (Small)	Inner diameter (Large)
Servo release accumulator	26.9 (1.059)	44.2 (1.740)
N-D accumulator	34.6 (1.362)	39.4 (1.551)

#### Return spring

Unit: mm (in)

Accumulator	Free length	Outer diameter
Servo release accumulator	52.5 (2.067)	20.4 (0.803)
N-D accumulator	43.5 (1.713)	28.0 (1.102)

### BAND SERVO

#### Return spring

Unit: mm (in)

Return spring	Free length	Outer diameter
2nd servo return spring	32.5 (1.280)	25.9 (1.020)
OD servo return spring	31.0 (1.220)	21.7 (0.854)

### REMOVAL AND INSTALLATION

Unit: mm (in)

Distance between end of converter housing and torque converter	14 (0.55)
----------------------------------------------------------------	-----------

### OUTPUT SHAFT

#### Seal ring clearance

Output shaft seal ring clearance mm (in)	
Standard	0.10 - 0.25 (0.0039 - 0.0098)
Allowable limit	0.25 (0.0098)

#### End play

Output shaft end play mm (in)	0 - 0.15 (0 - 0.0059)
----------------------------------	-----------------------

## SERVICE DATA AND SPECIFICATIONS (SDS)

### Specifications and Adjustments (Cont'd)

#### Output shaft adjusting shims

Thickness mm (in)	Part number
0.80 (0.0315)	31438-80X60
0.84 (0.0331)	31438-80X61
0.88 (0.0346)	31438-80X62
0.92 (0.0362)	31438-80X63
0.96 (0.0378)	31438-80X64
1.00 (0.0394)	31438-80X65
1.04 (0.0409)	31438-80X66
1.08 (0.0425)	31438-80X67
1.12 (0.0441)	31438-80X68
1.16 (0.0457)	31438-80X69
1.20 (0.0472)	31438-80X70

#### BEARING RETAINER

##### Seal ring clearance

Bearing retainer seal ring clearance mm (in)	
Standard	0.10 - 0.30 (0.0039 - 0.0118)
Allowable limit	0.30 (0.0118)

#### TOTAL END PLAY

Total end play	mm (in)	0.25 - 0.55 (0.0098 - 0.0217)
----------------	---------	-------------------------------

#### Bearing race for adjusting total end play

Thickness mm (in)	Part number
0.8 (0.031)	31435-80X00
1.0 (0.039)	31435-80X01
1.2 (0.047)	31435-80X02
1.4 (0.055)	31435-80X03
1.6 (0.063)	31435-80X04
1.8 (0.071)	31435-80X05
2.0 (0.079)	31435-80X06
0.9 (0.035)	31435-80X09
1.1 (0.043)	31435-80X10
1.3 (0.051)	31435-80X11
1.5 (0.059)	31435-80X12
1.7 (0.067)	31435-80X13
1.9 (0.075)	31435-80X14