

CL

SECTION

GI
MA
EM
LC
EC
FE
CL
MT
AT
FA
RA
BR
ST
RS
BT
HA
EL
IDX

CONTENTS

| | |
|--|---|
| <p>PRECAUTIONS AND PREPARATION2</p> <p style="padding-left: 20px;">Precautions2</p> <p style="padding-left: 20px;">Special Service Tools2</p> <p style="padding-left: 20px;">Commercial Service Tools2</p> <p>NOISE, VIBRATION AND HARSHNESS (NVH)</p> <p>TROUBLESHOOTING3</p> <p style="padding-left: 20px;">NVH Troubleshooting Chart3</p> <p>CLUTCH SYSTEM — Hydraulic Type4</p> <p>INSPECTION AND ADJUSTMENT5</p> <p style="padding-left: 20px;">Adjusting Clutch Pedal5</p> <p style="padding-left: 20px;">Bleeding Procedure6</p> | <p>HYDRAULIC CLUTCH CONTROL7</p> <p style="padding-left: 20px;">Clutch Master Cylinder7</p> <p style="padding-left: 20px;">Operating Cylinder8</p> <p>CLUTCH RELEASE MECHANISM9</p> <p>CLUTCH DISC AND CLUTCH COVER10</p> <p style="padding-left: 20px;">Clutch Disc10</p> <p style="padding-left: 20px;">Clutch Cover and Flywheel11</p> <p>SERVICE DATA AND SPECIFICATIONS (SDS)12</p> <p style="padding-left: 20px;">General Specifications12</p> <p style="padding-left: 20px;">Inspection and Adjustment12</p> |
|--|---|

PRECAUTIONS AND PREPARATION

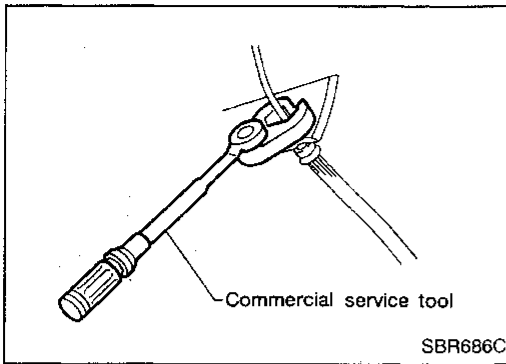

Precautions



- Recommended fluid is brake fluid "DOT 3".
- Never reuse drained brake fluid.
- Be careful not to splash brake fluid on painted areas.
- When removing and installing clutch piping, use Tool.
- Use new brake fluid to clean or wash all parts of master cylinder and operating cylinder.
- Never use mineral oils such as gasoline or kerosene. It will ruin the rubber parts of the hydraulic system.

WARNING:

After cleaning clutch disc, wipe it with a dust collector. Do not use compressed air.

Special Service Tools

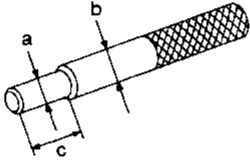
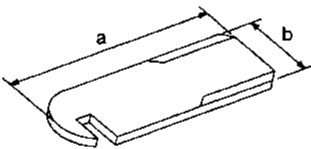
The actual shapes of Kent-Moore tools may differ from those of special service tools illustrated here.

| Tool number (Kent-Moore No.) Tool name | Description |
|--|--|
| ST20630000 (J26366) Clutch aligning bar |  <p>NT405</p> <p>Installing clutch cover and clutch disc</p> <p>a: 15.8 mm (0.622 in) dia. b: 22.9 mm (0.902 in) dia. c: 45.0 mm (1.772 in)</p> |
| ST20050240 (—) Diaphragm spring adjusting wrench |  <p>NT404</p> <p>Adjusting unevenness of diaphragm spring of clutch cover</p> <p>a: 150 mm (5.91 in) b: 25 mm (0.98 in)</p> |
| KV32101000 (J25689-A) Pin punch |  <p>NT410</p> <p>Removing and installing spring pin</p> <p>a: 4 mm (0.16 in) dia.</p> |

Commercial Service Tools

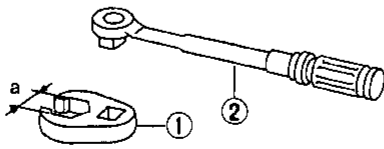
| Tool name | Description |
|---|---|
| ① Flare nut crowfoot ② Torque wrench |  <p>NT360</p> <p>Removing and installing clutch piping</p> <p>a: 10 mm (0.39 in)</p> |

NOISE, VIBRATION AND HARSHNESS (NVH) TROUBLESHOOTING

NVH Troubleshooting Chart

Use the chart below to help you find the cause of the symptom. The numbers indicate the order of the inspection. If necessary, repair or replace these parts.

| | | CL-5 | CL-6 | CL-7 | CL-8 | Refer to EM section. | CL-9 | CL-10 | CL-10 | CL-10 | CL-10 | CL-10 | CL-10 | CL-10 | CL-10 | CL-11 | CL-11 | CL-11 | | |
|-------------------------------------|---------------------------|--|---------------------------|--------------------------------------|---|-------------------------|--|---------------------------|-----------------------------------|-----------------------------|-------------------------------|--------------------|------------------------|------------------------|-------------------------------------|----------------------------|---|-----------------------------|-----------------------|--|
| Reference page | | CL-5 | CL-6 | CL-7 | CL-8 | Refer to EM section. | CL-9 | CL-10 | CL-10 | CL-10 | CL-10 | CL-10 | CL-10 | CL-10 | CL-10 | CL-11 | CL-11 | CL-11 | | |
| SUSPECTED PARTS (Possible cause) | | CLUTCH PEDAL (Free play out of adjustment) | CLUTCH LINE (Air in line) | MASTER CYLINDER PISTON CUP (Damaged) | OPERATING CYLINDER PISTON CUP (Damaged) | ENGINE MOUNTING (Loose) | RELEASE BEARING (Worn, dirty or damaged) | CLUTCH DISC (Out of true) | CLUTCH DISC (Runout is excessive) | CLUTCH DISC (Lining broken) | CLUTCH DISC (Dirty or burned) | CLUTCH DISC (Oily) | CLUTCH DISC (Worn out) | CLUTCH DISC (Hardened) | CLUTCH DISC (Lack of spline grease) | DIAPHRAGM SPRING (Damaged) | DIAPHRAGM SPRING (Out of tip alignment) | PRESSURE PLATE (Distortion) | FLYWHEEL (Distortion) | |
| Symptom | Clutch grabs/chatters | | | | | 1 | | | 2 | | | 2 | 2 | 2 | | | | 2 | | |
| | Clutch pedal spongy | | 1 | 2 | 2 | | | | | | | | | | | | | | | |
| | Clutch noisy | | | | | | 1 | | | | | | | | | | | | | |
| | Clutch slips | 1 | | | | | | | | | | 2 | 2 | | | 3 | | 4 | 5 | |
| | Clutch does not disengage | 1 | 2 | 3 | 4 | | | 5 | 5 | 5 | 5 | 5 | | | 5 | 6 | 6 | 7 | | |

GI
MA
EM
LC
EC
FE
CL
MT
AT
FA
RA
BR
ST
RS
BT
HA
EL
IDX

CLUTCH SYSTEM — Hydraulic Type

SEC. 300-305-306-465

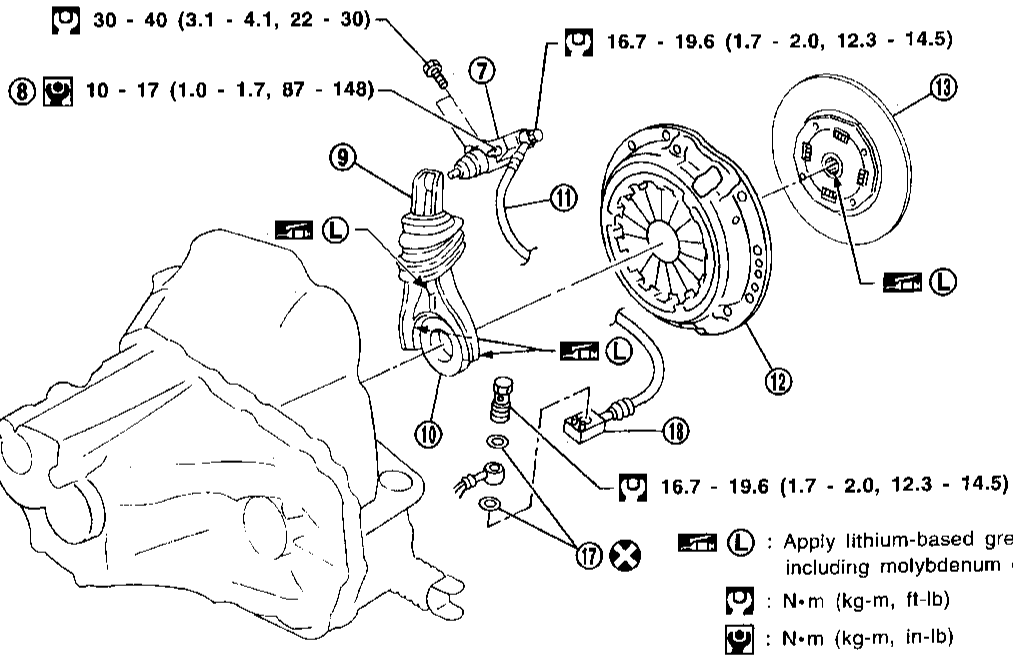
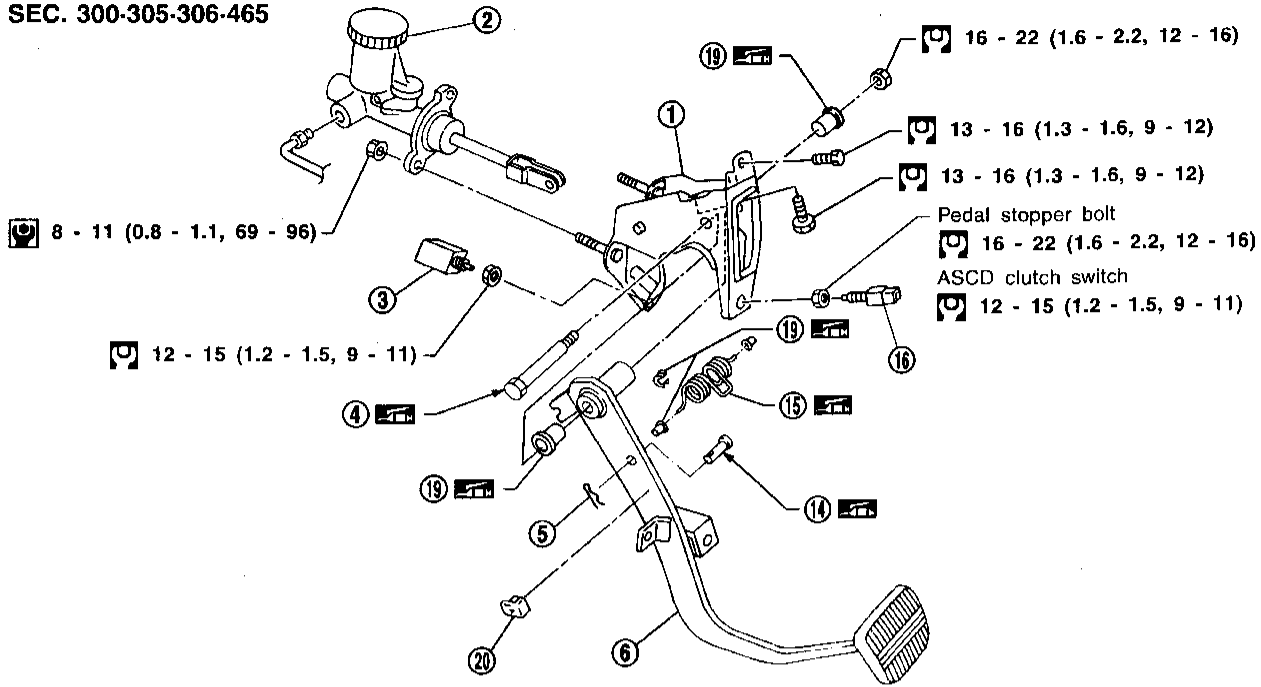

- ① Pedal bracket
- ② Clutch master cylinder
- ③ Clutch interlock switch
- ④ Fulcrum pin
- ⑤ Pin
- ⑥ Clutch pedal
- ⑦ Operating cylinder

- ⑧ Air bleeder screw
- ⑨ Withdrawal lever
- ⑩ Release bearing
- ⑪ Clutch hose
- ⑫ Clutch cover
- ⑬ Clutch disc
- ⑭ Clevis pin

- ⑮ Assist spring
- ⑯ ASCD clutch switch
- ⑰ Washer
- ⑱ Clutch hose connector
- ⑲ Bushing
- ⑳ Stopper rubber

L : Apply lithium-based grease including molybdenum disulphide.
 : N•m (kg-m, ft-lb)
 : N•m (kg-m, in-lb)

SCL714-B

Adjusting Clutch Pedal

1. Adjust pedal height with ASCD clutch switch or pedal stopper bolt.

Pedal height "H":

168 - 175 mm (6.61 - 6.89 in)

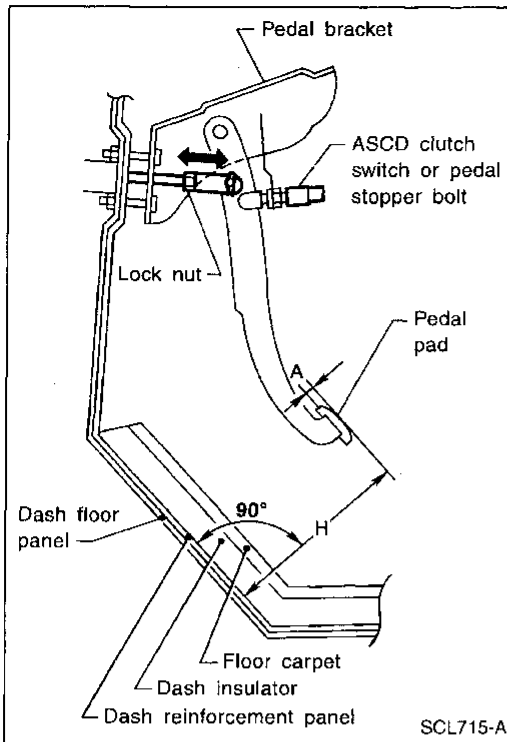

SCL715-A

2. Adjust pedal free play with master cylinder push rod. Then tighten lock nut.

Pedal free play "A":

9 - 16 mm (0.35 - 0.63 in)

- Push or step on clutch pedal until resistance is felt, and check the distance the pedal moves.

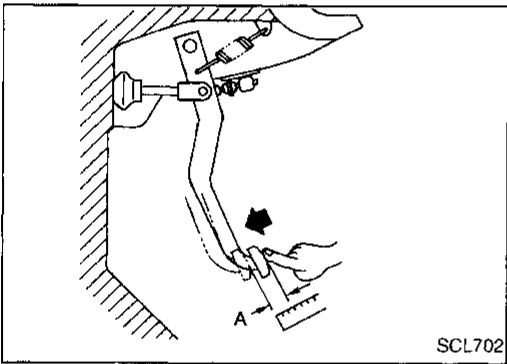

SCL702

3. Adjust clearance "C" shown in the figure while fully depressing clutch pedal fully.

Clearance C:

0.1 - 1.0 mm (0.004 - 0.039 in)

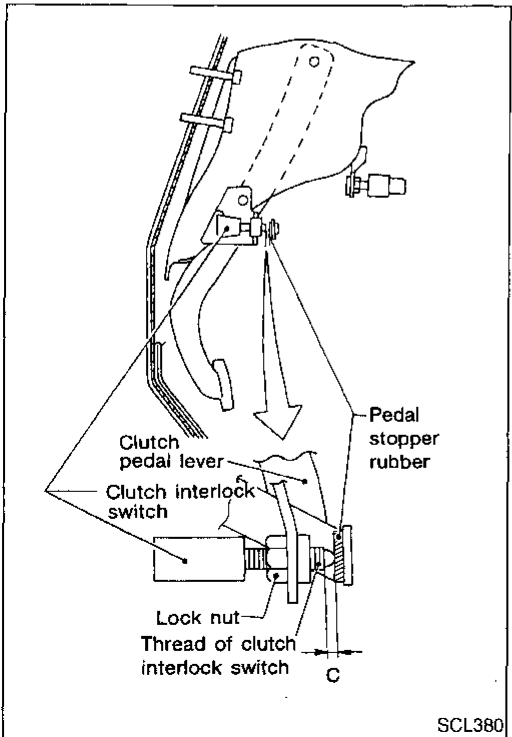

SCL380

GI

MA

EM

LC

EC

FE

CL

MT

AT

FA

RA

BR

ST

RS

BT

HA

EL

IDX

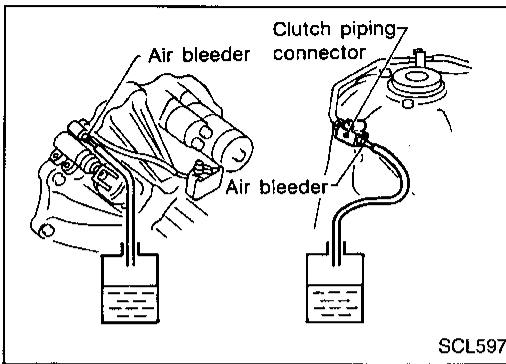

Bleeding Procedure

1. Bleed air from clutch operating cylinder according to the following procedure.

Carefully monitor fluid level at master cylinder during bleeding operation.

- a. Top up reservoir with recommended brake fluid.
 - b. Connect a transparent vinyl tube to air bleeder valve.
 - c. Slowly depress clutch pedal all the way several times.
 - d. With clutch pedal depressed, open bleeder valve to release air. Then close bleeder valve.
 - e. Release clutch pedal and wait for a few seconds.
 - f. Repeat steps c through e above until brake fluid flows from air bleeder valve without air bubbles.
2. Bleed air from clutch piping connector according to the above same procedure.
3. Repeat the above bleeding procedures 1 and 2 several times.

Clutch Master Cylinder

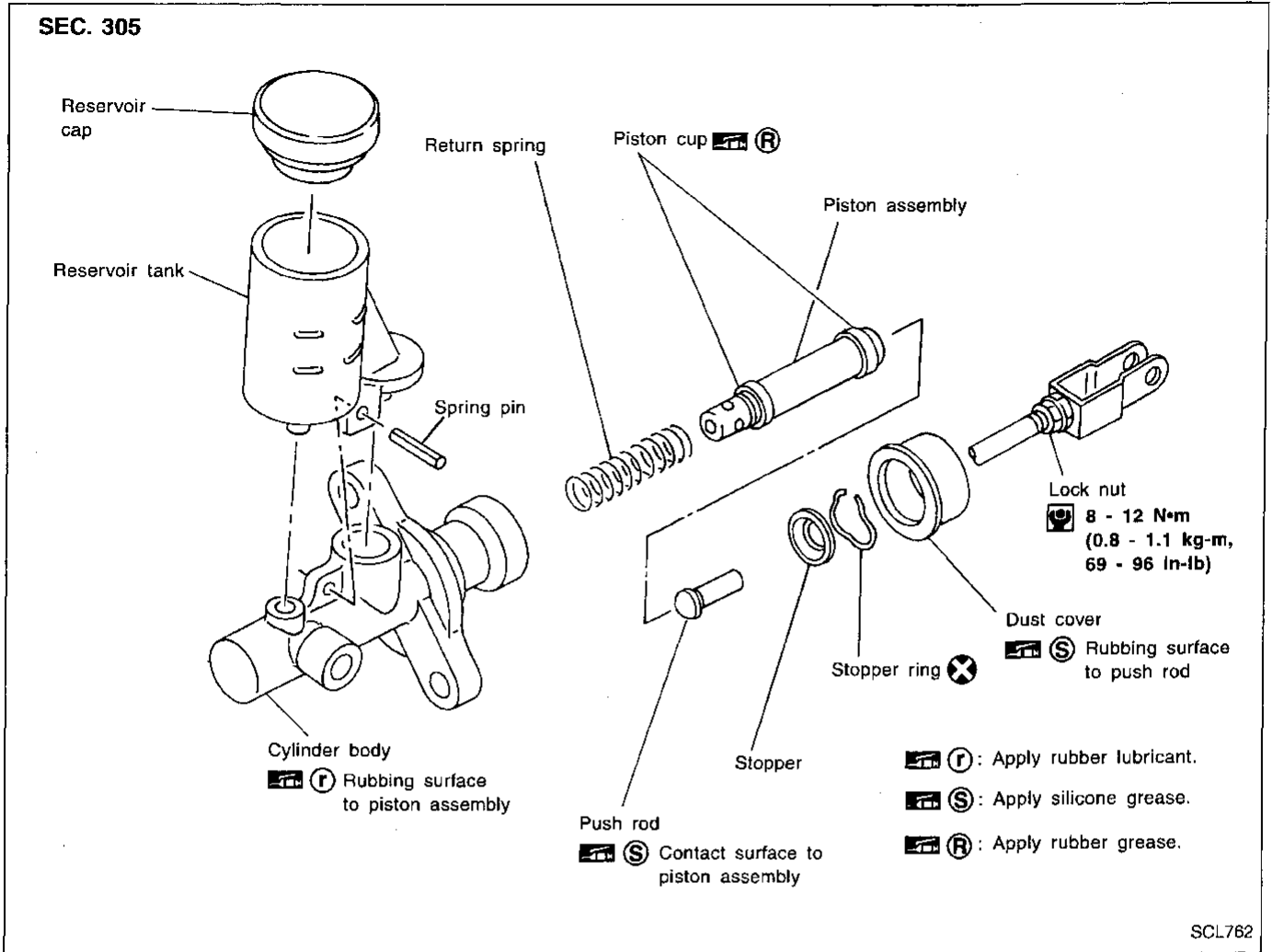

DISASSEMBLY AND ASSEMBLY

- Push piston into cylinder body with screwdriver when removing and installing valve stopper.

INSPECTION

Check the following items, and replace if necessary.

- Rubbing surface of cylinder and piston, for uneven wear, rust or damage
- Piston with piston cup, for wear or damage
- Return spring, for wear or damage
- Dust cover, for cracks, deformation or damage
- Reservoir, for deformation or damage

GI
MA
EM
LC
EC
FE
CL
MT
AT
FA
RA
BR
ST
RS
BT
HA
EL
IDX

Operating Cylinder

SEC. 306

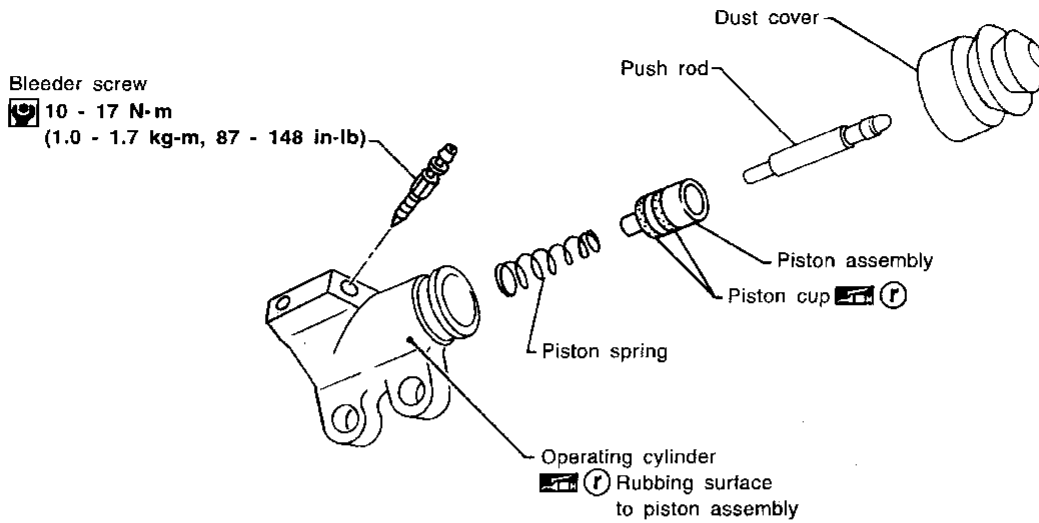

SCL709

INSPECTION

Check the following items, and replace if necessary.

- Rubbing surface of cylinder and piston, for uneven wear, rust or damage
- Piston with piston cup, for wear or damage
- Piston spring, for wear or damage
- Dust cover, for cracks, deformation or damage

CLUTCH RELEASE MECHANISM

SEC. 321

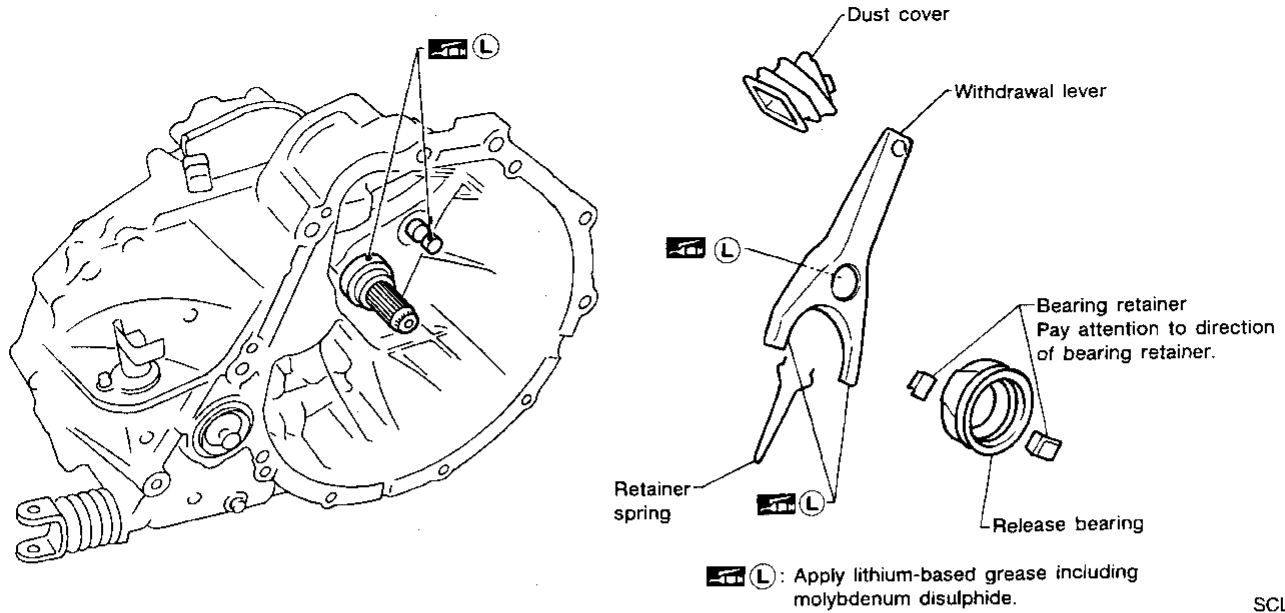

GI
MA
EM
LC
EC
FE
CL

INSPECTION

Check the following items, and replace if necessary.

- Release bearing, to see that it rolls freely and is free from noise, cracks, pitting or wear
- Release sleeve and withdrawal lever rubbing surface, for wear, rust or damage

MT
AT
FA
RA

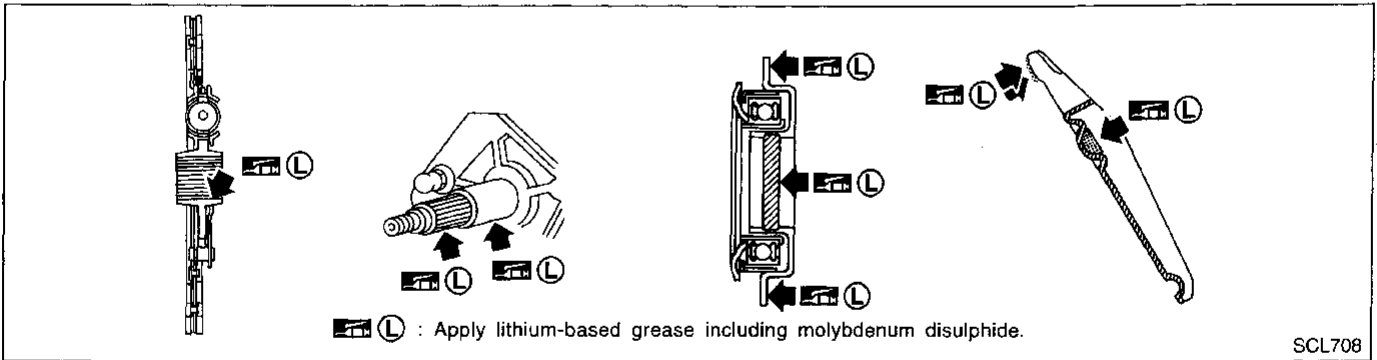

BR
ST
RS
BT
HA

LUBRICATION

- Apply recommended grease to contact surface and rubbing surface.
- Too much lubricant might damage clutch disc facing.

EL
IDX

CLUTCH DISC AND CLUTCH COVER

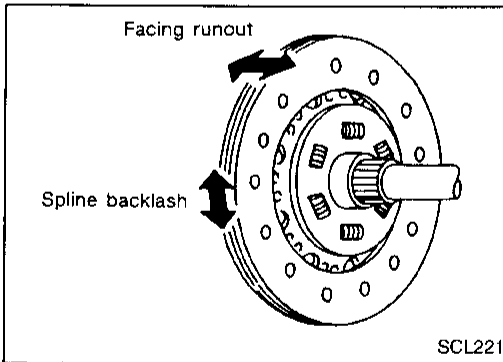
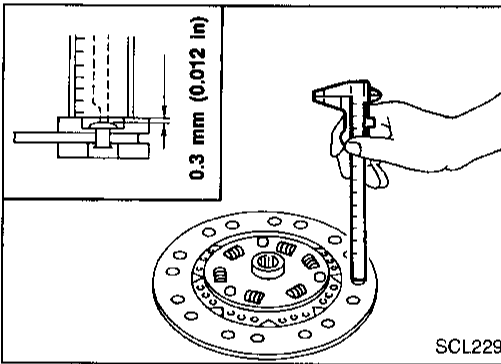
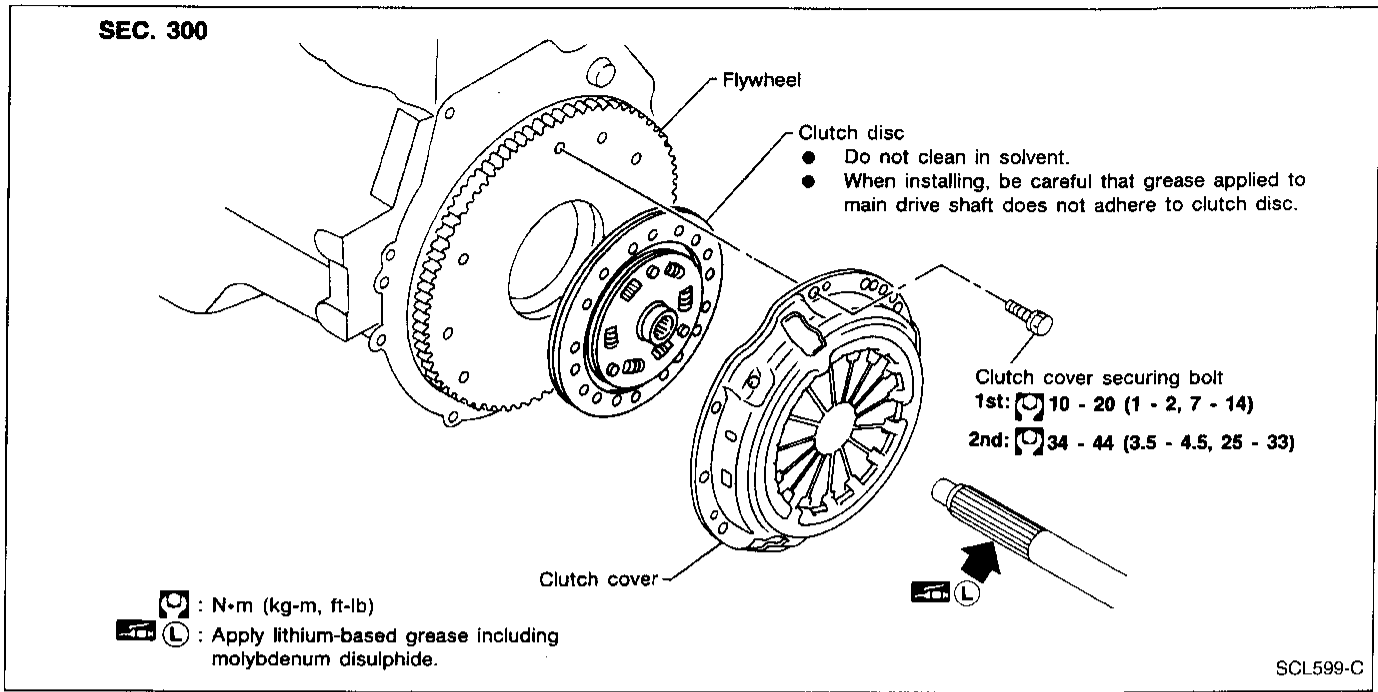

Clutch Disc

INSPECTION

Check the following items, and replace if necessary.

- Clutch disc, for burns, discoloration, oil or grease leakage
- Clutch disc, for wear of facing

Wear limit of facing surface to rivet head:
0.3 mm (0.012 in)

- Clutch disc, for spline backlash
Maximum spline backlash (at outer edge of disc):
1.0 mm (0.039 in)
- Clutch disc, for facing runout
Runout limit:
1.0 mm (0.039 in)
Distance of runout check point (from hub center)
115 mm (4.53 in)

INSTALLATION

- Apply recommended grease to contact surface of spline portion.
- Too much lubricant might damage clutch facing.

CLUTCH DISC AND CLUTCH COVER

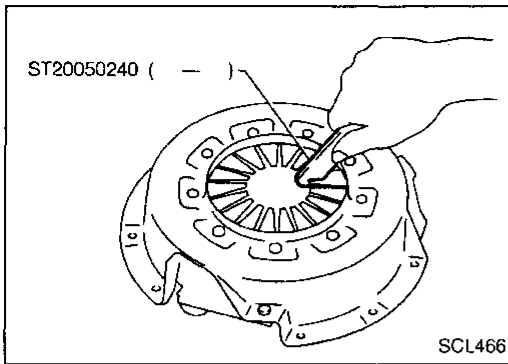

Clutch Cover and Flywheel

INSPECTION AND ADJUSTMENT

- Check clutch cover installed on vehicle for unevenness of diaphragm spring toe height.
Uneven limit:
0.5 mm (0.020 in)
- If out of limit, adjust the height with Tool.

GI

MA

EM

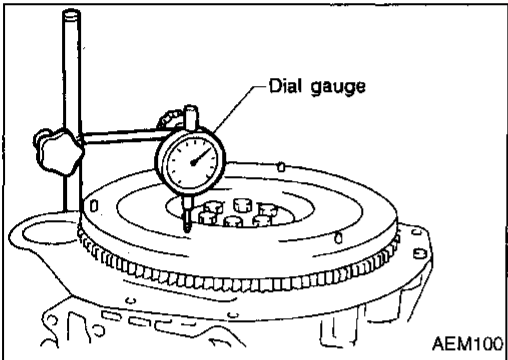

FLYWHEEL INSPECTION

- Check contact surface of flywheel for slight burns or discoloration. Repair flywheel with emery paper.
- Check flywheel runout.
Maximum allowable runout:
Refer to EM section ("Inspection", "CYLINDER BLOCK").

LC

EC

FE

CL

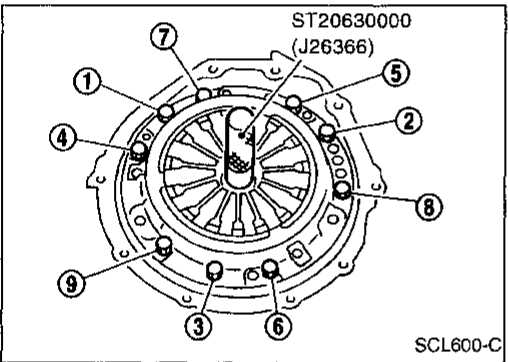

INSTALLATION

- Insert Tool into clutch disc hub when installing clutch cover and disc.
- Tighten bolts in numerical order.
- **Be careful not to allow grease to contaminate clutch facing.**

MT

AT

FA

First step:

: 10 - 20 N·m (1 - 2 kg·m, 7 - 14 ft·lb)

Final step:

: 34 - 44 N·m (3.5 - 4.5 kg·m, 25 - 33 ft·lb)

RA

BR

ST

RS

BT

HA

EL

IDX

SERVICE DATA AND SPECIFICATIONS (SDS)

General Specifications

CLUTCH CONTROL SYSTEM

| | |
|------------------------|-----------|
| Type of clutch control | Hydraulic |
|------------------------|-----------|

CLUTCH MASTER CYLINDER

| | | |
|----------------|---------|-------------|
| Inner diameter | mm (in) | 15.87 (5/8) |
|----------------|---------|-------------|

CLUTCH OPERATING CYLINDER

| | | |
|----------------|---------|-------------|
| Inner diameter | mm (in) | 19.05 (3/4) |
|----------------|---------|-------------|

CLUTCH DISC

Unit: mm (in)

| | |
|---|--|
| Model | 240 |
| Facing size (Outer dia. x inner dia. x thickness) | 240 x 160 x 3.5 (9.45 x 6.30 x 0.138) |
| Thickness of disc assembly | |
| With load | 7.6 - 8.0 (0.299 - 0.315) with 5,688 N (580 kg, 1,279 lb) |

CLUTCH COVER

| | |
|----------|-------------------------------|
| Model | 240 |
| Set load | N (kg, lb) 5,688 (580, 1,279) |

Inspection and Adjustment

CLUTCH PEDAL

Unit: mm (in)

| | |
|--|---------------------------|
| Pedal height* | 168 - 175 (6.61 - 6.89) |
| Pedal free play | 9 - 16 (0.35 - 0.63) |
| Clearance between pedal stopper rubber and clutch interlock switch threaded end while clutch pedal is fully depressed. | 0.1 - 1.0 (0.004 - 0.039) |

*: Measured from surface of dash reinforcement panel to surface of pedal pad

CLUTCH DISC

Unit: mm (in)

| | |
|--|-------------|
| Model | 240 |
| Wear limit of facing surface to rivet head | 0.3 (0.012) |
| Facing runout limit | 1.0 (0.039) |
| Distance of runout check point (from the hub center) | 115 (4.53) |
| Maximum spline backlash (at outer edge of disc) | 1.0 (0.039) |

CLUTCH COVER

Unit: mm (in)

| | |
|---|-------------|
| Model | 240 |
| Uneven limit of diaphragm spring toe height | 0.5 (0.020) |