

STARTING & CHARGING SYSTEMS

SECTION SC

CONTENTS

PRECAUTIONS	2	YOKE CHECK	17
Supplemental Restraint System (SRS) "AIR BAG" and "SEAT BELT PRE-TENSIONER"	2	ARMATURE CHECK	17
Wiring Diagrams and Trouble Diagnosis	2	Assembly	18
BATTERY	3	PINION PROTRUSION LENGTH ADJUSTMENT	18
How to Handle Battery	3	CHARGING SYSTEM	19
METHODS OF PREVENTING OVER-DISCHARGE	3	System Description	19
CHECKING ELECTROLYTE LEVEL	3	Wiring Diagram - CHARGE -	20
SPECIFIC GRAVITY CHECK	4	Trouble Diagnoses	21
Battery Test and Charging Chart	6	WITH IC REGULATOR	21
CHART I	6	MALFUNCTION INDICATOR	21
CHART II	7	Construction	22
A: SLOW CHARGE	8	Removal and Installation	22
B: STANDARD CHARGE	9	REMOVAL	22
C: QUICK CHARGE	11	INSTALLATION	22
STARTING SYSTEM	12	Disassembly	23
System Description	12	REAR COVER	23
M/T MODELS	12	REAR BEARING	23
A/T MODELS	12	Inspection	23
Wiring Diagram - START -	13	ROTOR CHECK	23
Trouble Diagnoses	14	BRUSH CHECK	23
Construction	15	STATOR CHECK	24
Removal and Installation	15	Assembly	24
REMOVAL	15	RING FITTING IN REAR BEARING	24
INSTALLATION	15	REAR COVER INSTALLATION	24
Inspection	16	SERVICE DATA AND SPECIFICATIONS (SDS)	25
MAGNETIC SWITCH CHECK	16	Battery	25
PINION/CLUTCH CHECK	16	Starter	25
BRUSH CHECK	16	Alternator	25

PRECAUTIONS

Supplemental Restraint System (SRS) "AIR BAG" and "SEAT BELT PRE-TENSIONER"

Supplemental Restraint System (SRS) "AIR BAG" and "SEAT BELT PRE-TENSIONER"

NFSC0001

The Supplemental Restraint System such as "AIR BAG" and "SEAT BELT PRE-TENSIONER" used along with a seat belt, helps to reduce the risk or severity of injury to the driver and front passenger for certain types of collision. The SRS system composition which is available to NISSAN MODEL A33 is as follows (The composition varies according to the destination and optional equipment.):

- For a frontal collision
The Supplemental Restraint System consists of driver air bag module (located in the center of the steering wheel), front passenger air bag module (located on the instrument panel on passenger side), seat belt pre-tensioners, a diagnosis sensor unit, warning lamp, wiring harness and spiral cable.
- For a side collision
The Supplemental Restraint System consists of front side air bag module (located in the outer side of front seat), satellite sensor, diagnosis sensor unit (one of components of air bags for a frontal collision), wiring harness, warning lamp (one of components of air bags for a frontal collision).

Information necessary to service the system safely is included in the **RS section** of this Service Manual.

WARNING:

- **To avoid rendering the SRS inoperative, which could increase the risk of personal injury or death in the event of a collision which would result in air bag inflation, all maintenance should be performed by an authorized NISSAN dealer.**
- **Improper maintenance, including incorrect removal and installation of the SRS, can lead to personal injury caused by unintentional activation of the system. For removal of Spiral Cable and Air Bag Module, see the RS section.**
- **Do not use electrical test equipment on any circuit related to the SRS unless instructed to in this Service Manual. SRS wiring harnesses can be identified with yellow harness connector (and with yellow harness protector or yellow insulation tape before the harness connectors).**

Wiring Diagrams and Trouble Diagnosis

NFSC0002

When you read wiring diagrams, refer to the following:

- Refer to GI-11, "HOW TO READ WIRING DIAGRAMS"
- Refer to EL-9, "POWER SUPPLY ROUTING" for power distribution circuit

When you perform trouble diagnosis, refer to the following:

- Refer to GI-32, "HOW TO FOLLOW TEST GROUP IN TROUBLE DIAGNOSIS"
- Refer to GI-21, "HOW TO PERFORM EFFICIENT DIAGNOSIS FOR AN ELECTRICAL INCIDENT"

BATTERY

How to Handle Battery

How to Handle Battery

NFSC0003

CAUTION:

If it becomes necessary to start the engine with a booster battery and jumper cables,

- 1) Use a 12-volt booster battery.
- 2) After connecting battery cables, ensure that they are tightly clamped to battery terminals for good contact.
- 3) Never add distilled water through the hole used to check specific gravity.

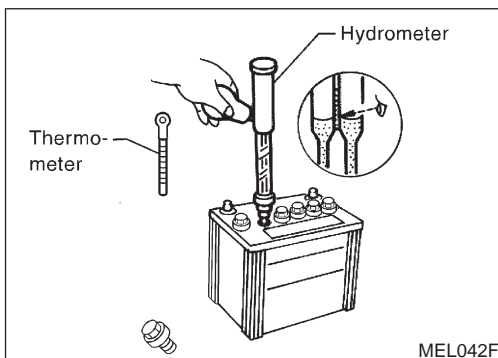
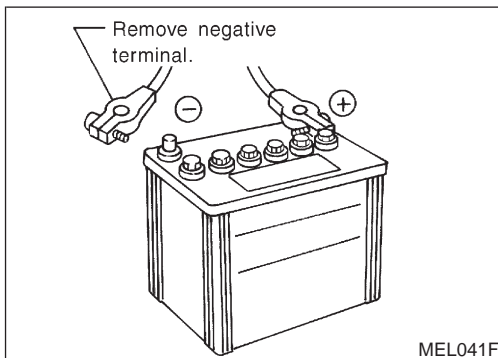
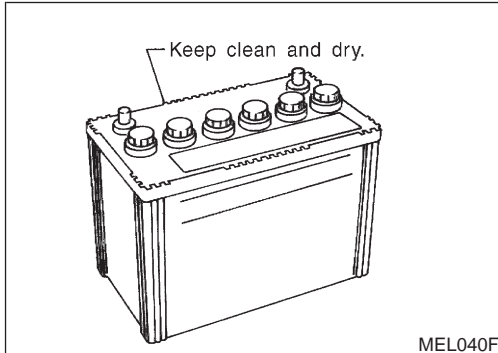

METHODS OF PREVENTING OVER-DISCHARGE

NFSC0003S01

The following precautions must be taken to prevent over-discharging a battery.

- The battery surface (particularly its top) should always be kept clean and dry.
- The terminal connections should be clean and tight.
- At every routine maintenance, check the electrolyte level. This also applies to batteries designated as "low maintenance" and "maintenance-free".
- When the vehicle is not going to be used over a long period of time, disconnect the negative battery terminal.
- Check the charge condition of the battery. Periodically check the specific gravity of the electrolyte. Keep a close check on charge condition to prevent over-discharge.

CHECKING ELECTROLYTE LEVEL

NFSC0003S02

WARNING:

Do not allow battery fluid to come in contact with skin, eyes, fabrics, or painted surfaces. After touching a battery, do not touch or rub your eyes until you have thoroughly washed your hands. If acid contacts eyes, skin or clothing, immediately flush with water for 15 minutes and seek medical attention.

BATTERY

How to Handle Battery (Cont'd)

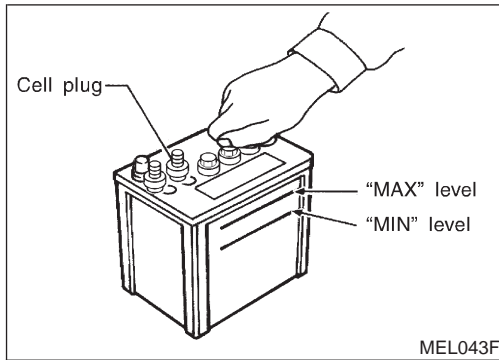

- Remove the cell plug using a suitable tool.
- Add distilled water up to the MAX level.

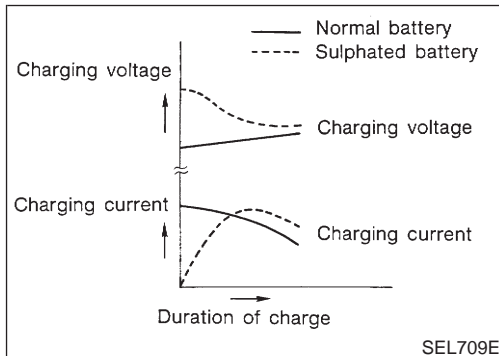

Sulphation

NFSC0003S0201

A battery will be completely discharged if it is left unattended for a long time and the specific gravity will become less than 1.100. This may result in sulphation on the cell plates.

To determine if a battery has been "sulphated", note its voltage and current when charging it. As shown in the figure, less current and higher voltage are observed in the initial stage of charging sulphated batteries.

A sulphated battery may sometimes be brought back into service by means of a long, slow charge, 12 hours or more, followed by a battery capacity test.

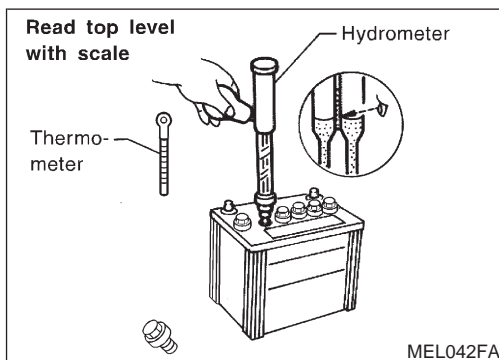

SPECIFIC GRAVITY CHECK

NFSC0003S03

1. Read hydrometer and thermometer indications at eye level.

2. Convert into specific gravity at 20°C (68°F).

Example:

- When electrolyte temperature is 35°C (95°F) and specific gravity of electrolyte is 1.230, converted specific gravity at 20°C (68°F) is 1.240.
- When electrolyte temperature is 0°C (32°F) and specific gravity of electrolyte is 1.210, converted specific gravity at 20°C (68°F) is 1.196.

BATTERY

How to Handle Battery (Cont'd)

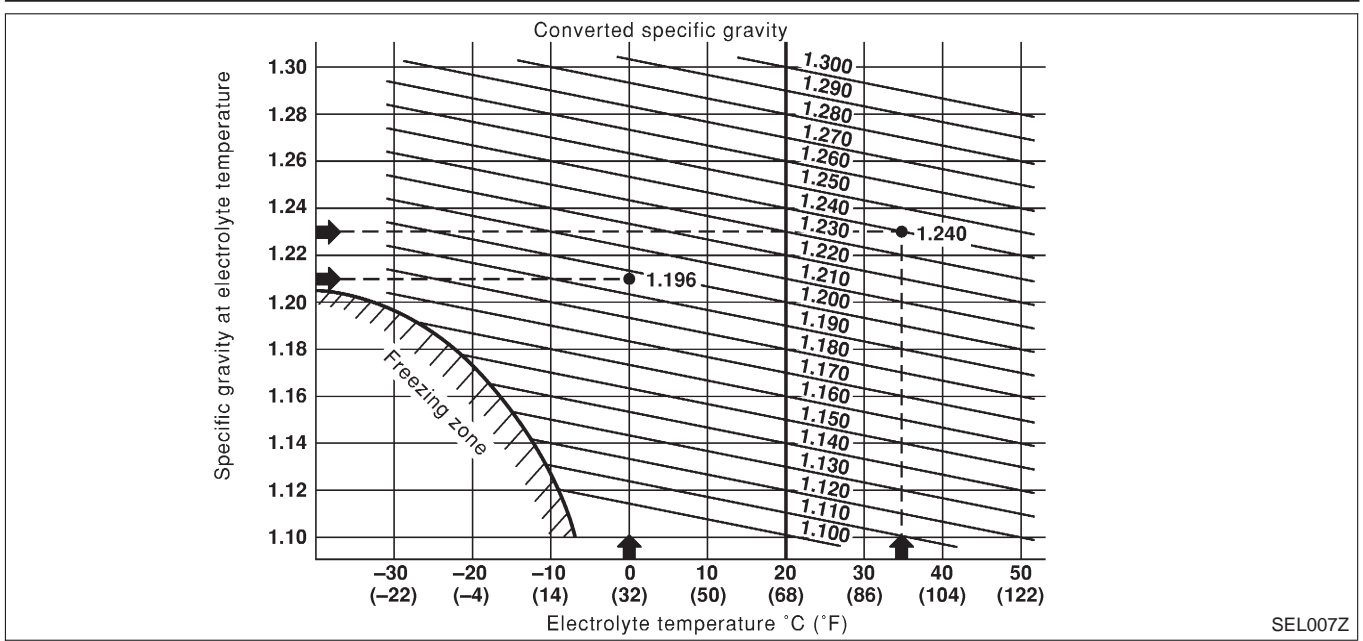

SEL007Z

BATTERY

Battery Test and Charging Chart

CHART I

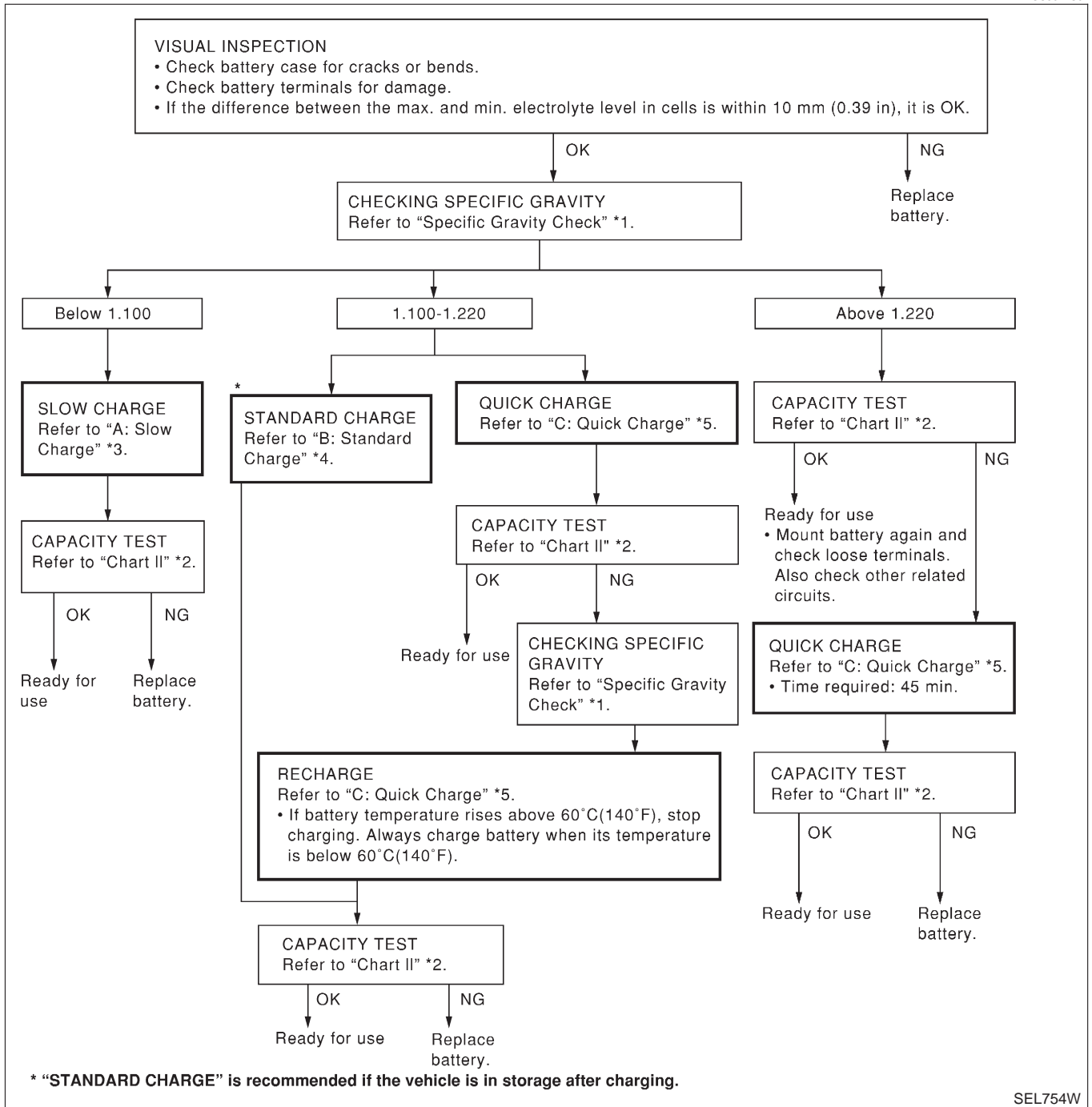

*1: SC-4
*2: SC-7

*3: SC-8
*4: SC-9

*5: SC-11

BATTERY

Battery Test and Charging Chart (Cont'd)

CHART II

NFSC0017S02

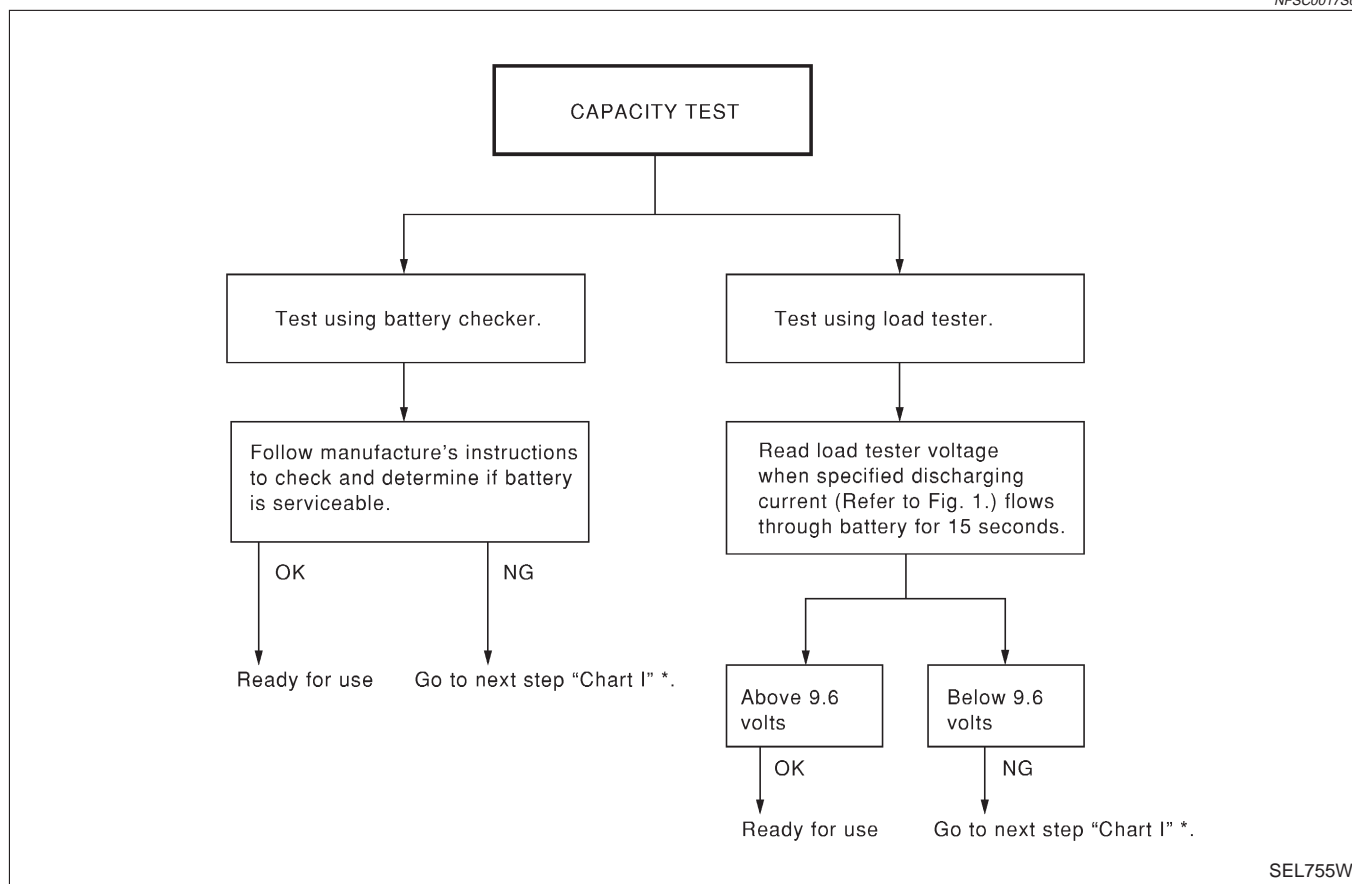

SEL755W

*: SC-6

- Check battery type and determine the specified current using the following table.

Fig. 1 Discharging Current (Load Tester)

NFSC0017S0201

Type	Current (A)
28B19R(L)	90
34B19R(L)	99
46B24R(L)	135
55B24R(L)	135
50D23R(L)	150
55D23R(L)	180
65D26R(L)	195
80D26R(L)	195
75D31R(L)	210
95D31R(L)	240
115D31R(L)	240
95E41R(L)	300
130E41R(L)	330

BATTERY

Battery Test and Charging Chart (Cont'd)

A: SLOW CHARGE

NFSC0017S03

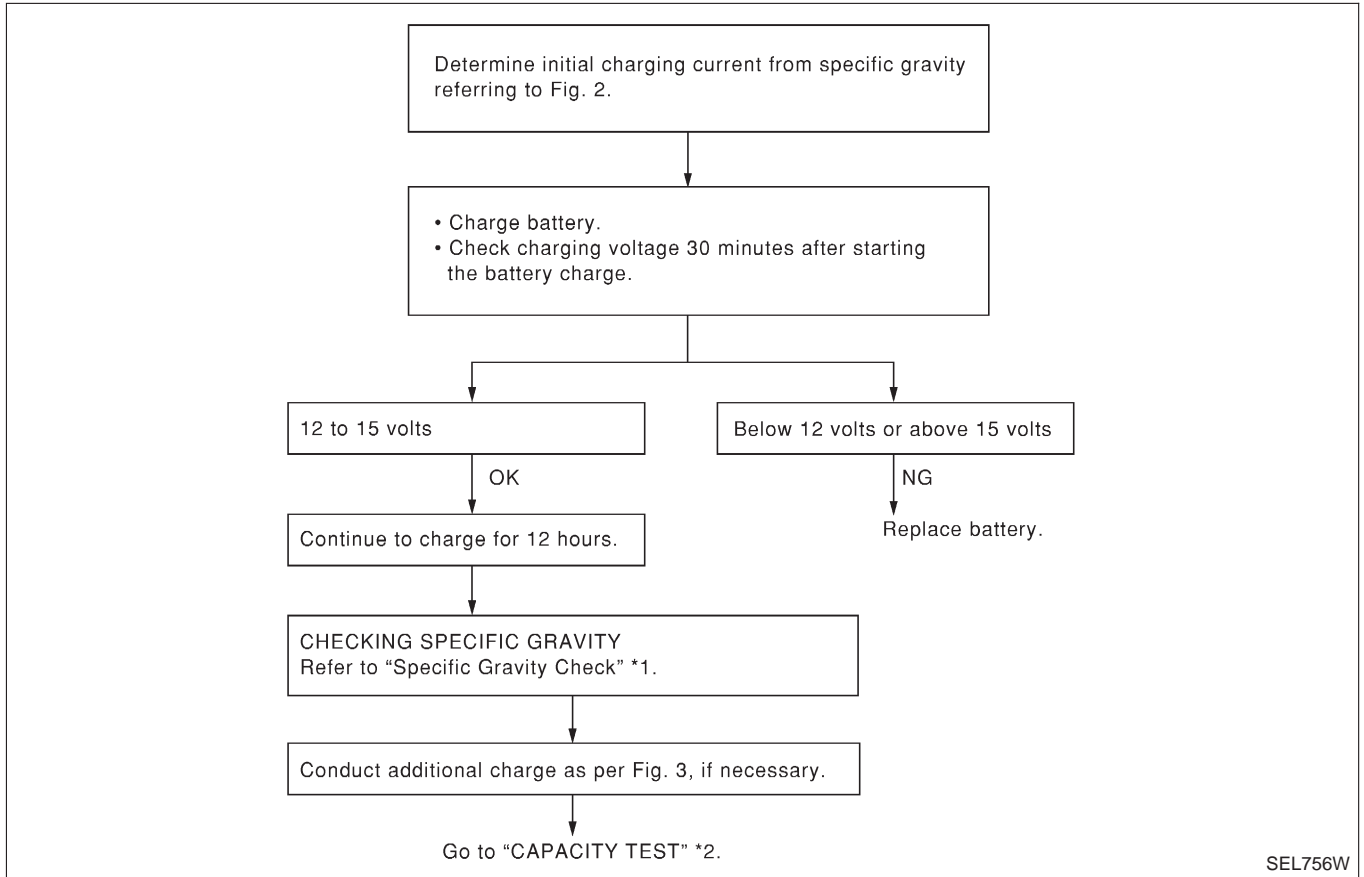

SEL756W

*1: SC-4

*2: SC-7

Fig. 2 Initial Charging Current Setting (Slow Charge)

NFSC0017S0301

CON-VERTED SPECIFIC GRAVITY	BATTERY TYPE												
	28B19R(L)	34B19R(L)	46B24R(L)	55B24R(L)	50D23R(L)	55D23R(L)	65D26R(L)	80D26R(L)	75D31R(L)	95D31R(L)	115D31R(L)	95E41R(L)	130E41R(L)
Below 1.100	4.0 (A)		5.0 (A)		7.0 (A)		8.0 (A)		9.0 (A)	10.0 (A)			14.0 (A)

- Check battery type and determine the specified current using the table shown above.
- After starting charging, adjustment of charging current is not necessary.

BATTERY

Fig. 3 Additional Charge (Slow Charge)

=NFSC0017S0302

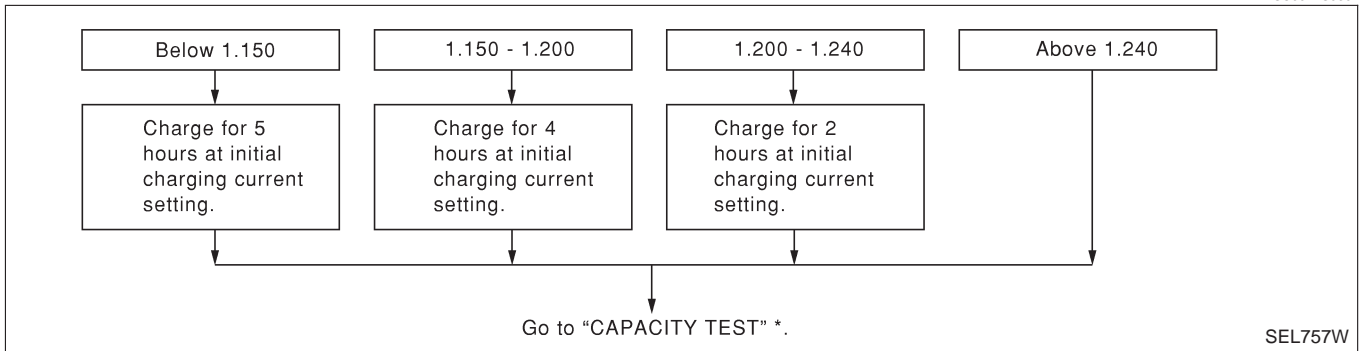

*: SC-7

CAUTION:

- Set charging current to value specified in Fig. 2. If charger is not capable of producing specified current value, set its charging current as close to that value as possible.
- Keep battery away from open flame while it is being charged.
- When connecting charger, connect leads first, then turn on charger. Do not turn on charger first, as this may cause a spark.
- If battery temperature rises above 60°C (140°F), stop charging. Always charge battery when its temperature is below 60°C (140°F).

B: STANDARD CHARGE

NFSC0017S04

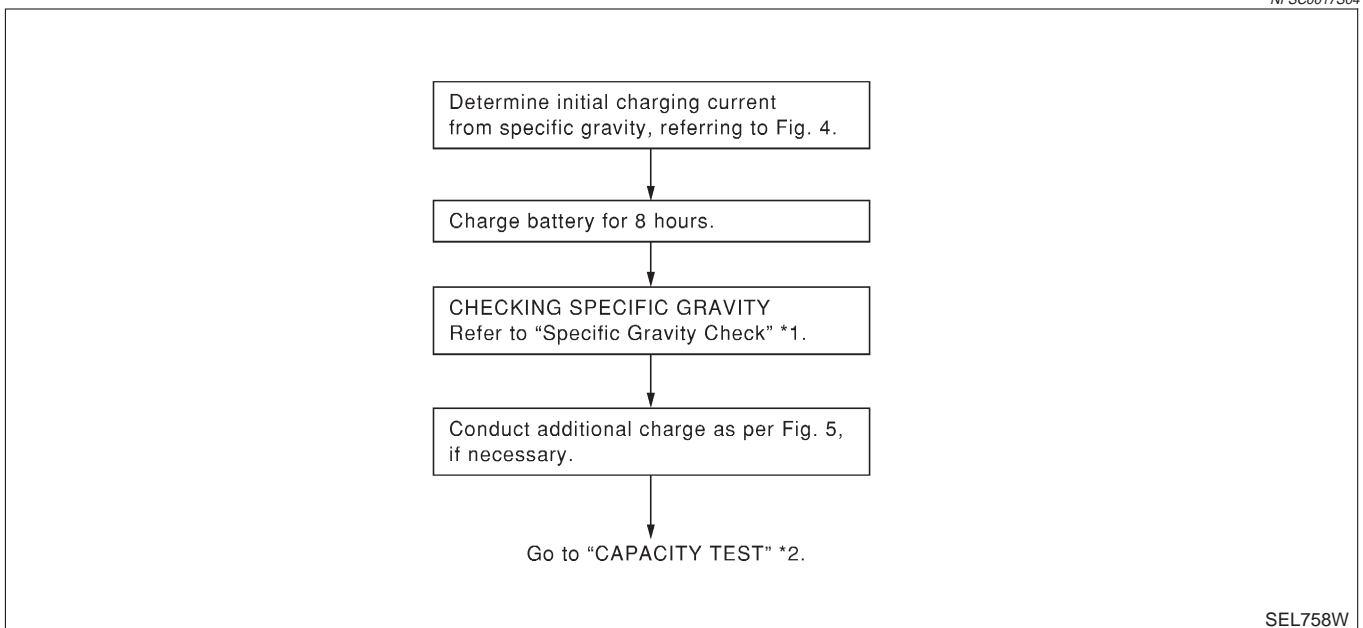

*1: SC-4

*2: SC-7

BATTERY

Battery Test and Charging Chart (Cont'd)

Fig. 4 Initial Charging Current Setting (Standard Charge)

NFSC0017S0401

CON-VERTED SPECIFIC GRAVITY	BATTERY TYPE												
	28B19R(L)	34B19R(L)	46E24R(L)	55B24R(L)	50D23R(L)	55D23R(L)	65D26R(L)	80D26R(L)	75D31R(L)	95D31R(L)	115D31R(L)	95E41R(L)	130E41R(L)
1.100 - 1.130	4.0 (A)		5.0 (A)		6.0 (A)		7.0 (A)		8.0 (A)	9.0 (A)			13.0 (A)
1.130 - 1.160	3.0 (A)		4.0 (A)		5.0 (A)		6.0 (A)		7.0 (A)	8.0 (A)			11.0 (A)
1.160 - 1.190	2.0 (A)		3.0 (A)		4.0 (A)		5.0 (A)		6.0 (A)	7.0 (A)			9.0 (A)
1.190 - 1.220	2.0 (A)		2.0 (A)		3.0 (A)		4.0 (A)		5.0 (A)	5.0 (A)			7.0 (A)

- Check battery type and determine the specified current using the table shown above.
- After starting charging, adjustment of charging current is not necessary.

Fig. 5 Additional Charge (Standard Charge)

NFSC0017S0402

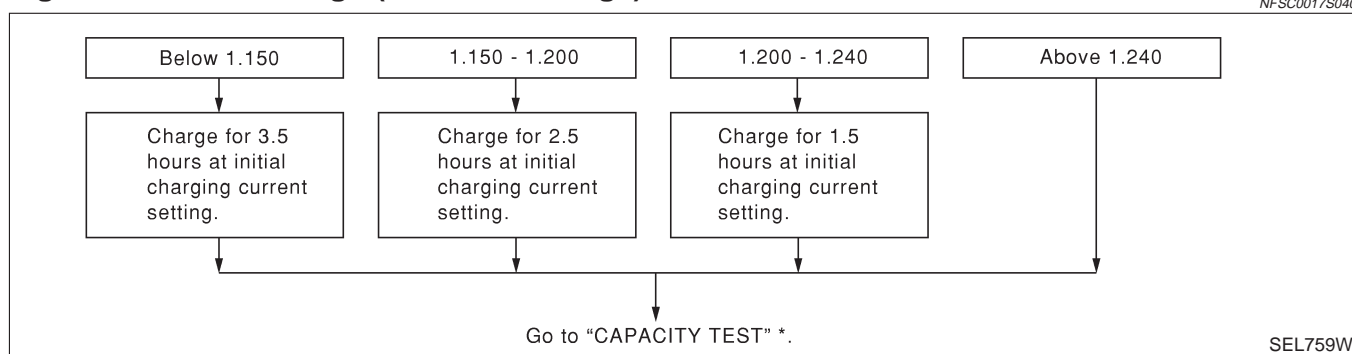

SEL759W

*: SC-7

CAUTION:

- Do not use standard charge method on a battery whose specific gravity is less than 1.100.
- Set charging current to value specified in Fig. 4. If charger is not capable of producing specified current value, set its charging current as close to that value as possible.
- Keep battery away from open flame while it is being charged.
- When connecting charger, connect leads first, then turn on charger. Do not turn on charger first, as this may cause a spark.
- If battery temperature rises above 60°C (140°F), stop charging. Always charge battery when its temperature is below 60°C (140°F).

BATTERY

Battery Test and Charging Chart (Cont'd)

C: QUICK CHARGE

=NFSC0017S05

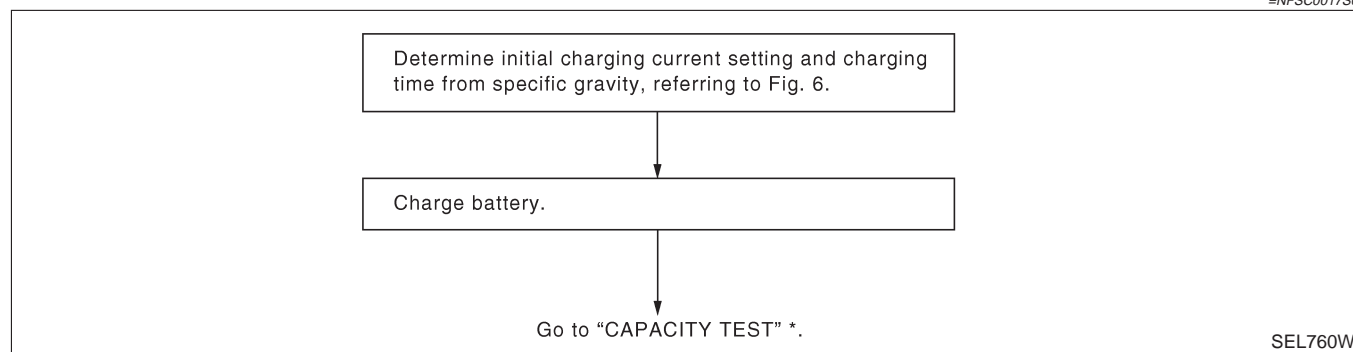

SEL760W

*: SC-7

Fig. 6 Initial Charging Current Setting and Charging Time (Quick Charge)

NFSC0017S0501

BATTERY TYPE		28B19R(L)	34B19R(L)	46B24R(L)	55B24R(L)	50D23R(L)	55D23R(L)	65D26R(L)	80D26R(L)	75D31R(L)	95D31R(L)	115D31R(L)	95E41R(L)	130E41R(L)
		10 (A)		15 (A)			20 (A)			30 (A)			40 (A)	
CONVERTED SPECIFIC GRAVITY	1.100 - 1.130	2.5 hours												
	1.130 - 1.160	2.0 hours												
	1.160 - 1.190	1.5 hours												
	1.190 - 1.220	1.0 hours												
	Above 1.220	0.75 hours (45 min.)												

- Check battery type and determine the specified current using the table shown above.
- After starting charging, adjustment of charging current is not necessary.

CAUTION:

- Do not use quick charge method on a battery whose specific gravity is less than 1.100.
- Set initial charging current to value specified in Fig. 6. If charger is not capable of producing specified current value, set its charging current as close to that value as possible.
- Keep battery away from open flame while it is being charged.
- When connecting charger, connect leads first, then turn on charger. Do not turn on charger first, as this may cause a spark.
- Be careful of a rise in battery temperature because a large current flow is required during quick-charge operation.
If battery temperature rises above 60°C (140°F), stop charging. Always charge battery when its temperature is below 60°C (140°F).
- Do not exceed the charging time specified in Fig. 6, because charging battery over the charging time can cause deterioration of the battery.

STARTING SYSTEM

System Description

System Description

NFSC0004

M/T MODELS

NFSC0004S01

Power is supplied at all times

- to ignition switch terminal 1
- through 40A fusible link (letter **C**, located in the fuse and fusible link box) and

With the ignition switch in the START position, power is supplied

- from ignition switch terminal 5
- through theft warning relay terminals 3 and 4
- to starter motor harness connector terminal 2.

The starter motor plunger closes and provides a closed circuit between the battery and starter motor. The starter motor is grounded to the engine block. With power and ground supplied, cranking occurs and the engine starts.

A/T MODELS

NFSC0004S02

Power is supplied at all times

- to ignition switch terminal 1
- through 40A fusible link (letter **C**, located in the fuse and fusible link box).

With the ignition switch in the ON or START position, power is supplied through 15A fuse [No. 20, located in the fuse block (J/B)]

- to park/neutral position relay terminal 1.

Also, with the ignition switch in the START position, power is supplied

- from ignition switch terminal 5
- to park/neutral position relay terminal 6.

With the selector lever in the P or N position, ground is supplied

- to park/neutral position relay terminal 2 through the park/neutral position switch
- from body grounds, F39 and F41.

Then park/neutral position relay is energized and power is supplied

- from park/neutral position relay terminal 7
- through theft warning relay terminals 3 and 4
- to starter motor harness connector terminal 2.

The starter motor plunger closes and provides a closed circuit between the battery and starter motor. The starter motor is grounded to the engine block. With power and ground supplied, cranking occurs and the engine starts.

STARTING SYSTEM

Wiring Diagram — START —

Wiring Diagram — START —

NFSC0005

SC-START-01

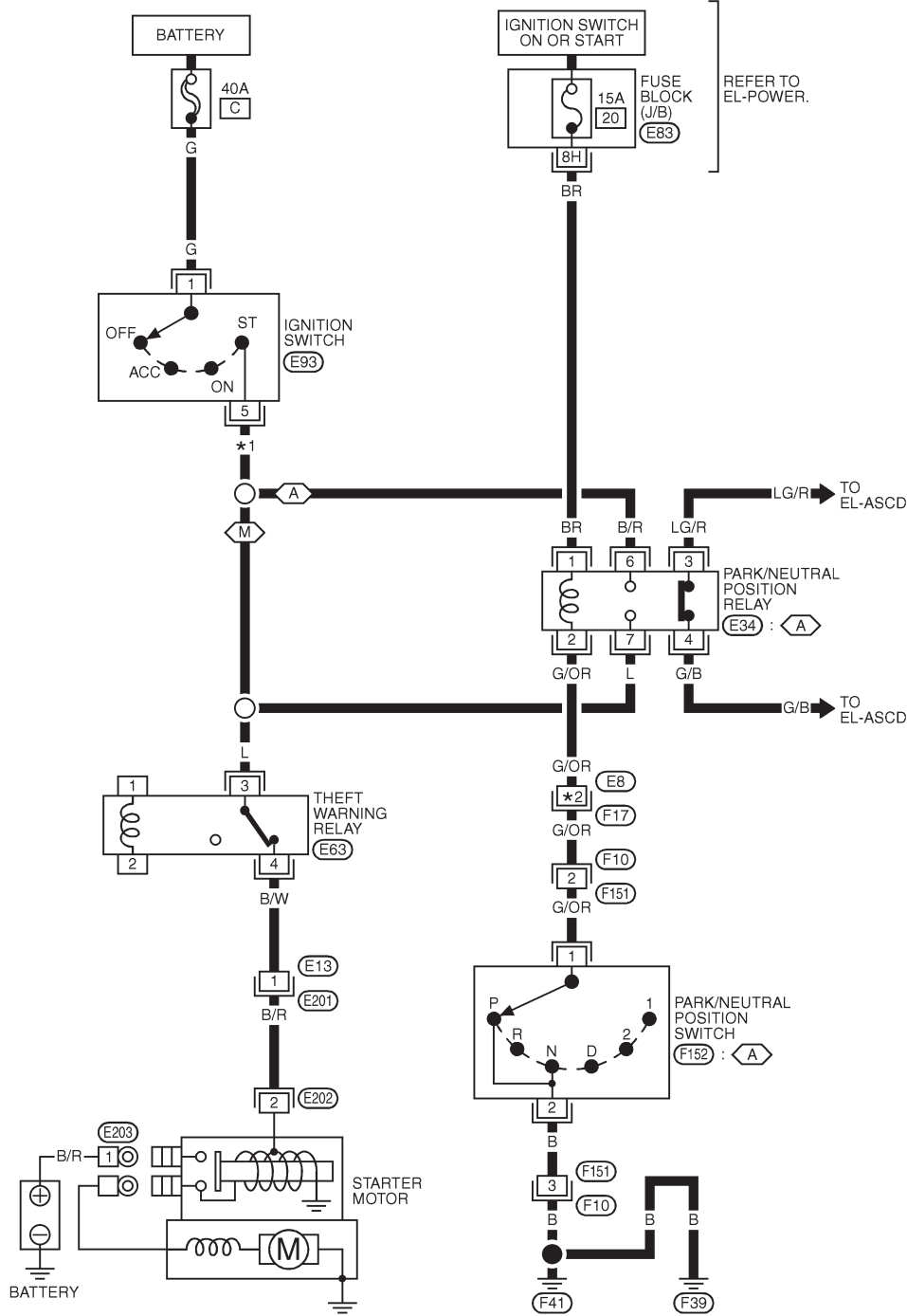

- ◊ L : LHD MODELS
- ◊ R : RHD MODELS
- ◊ A : WITH A/T
- ◊ M : WITH M/T

- *1 B/R : ◊ A
- L : ◊ M
- *2 1 : ◊ L
- 2 : ◊ R

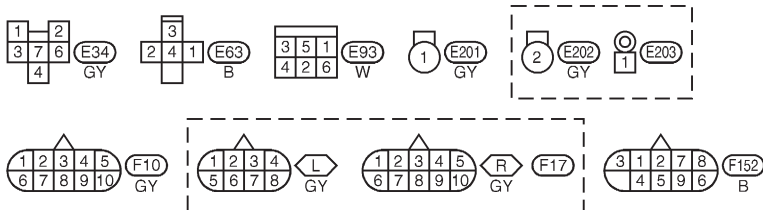

REFER TO THE FOLLOWING.
 (E83) - FUSE BLOCK-
 JUNCTION BOX (J/B)

MEL153M

STARTING SYSTEM

Trouble Diagnoses

If any abnormality is found, immediately disconnect battery negative terminal.

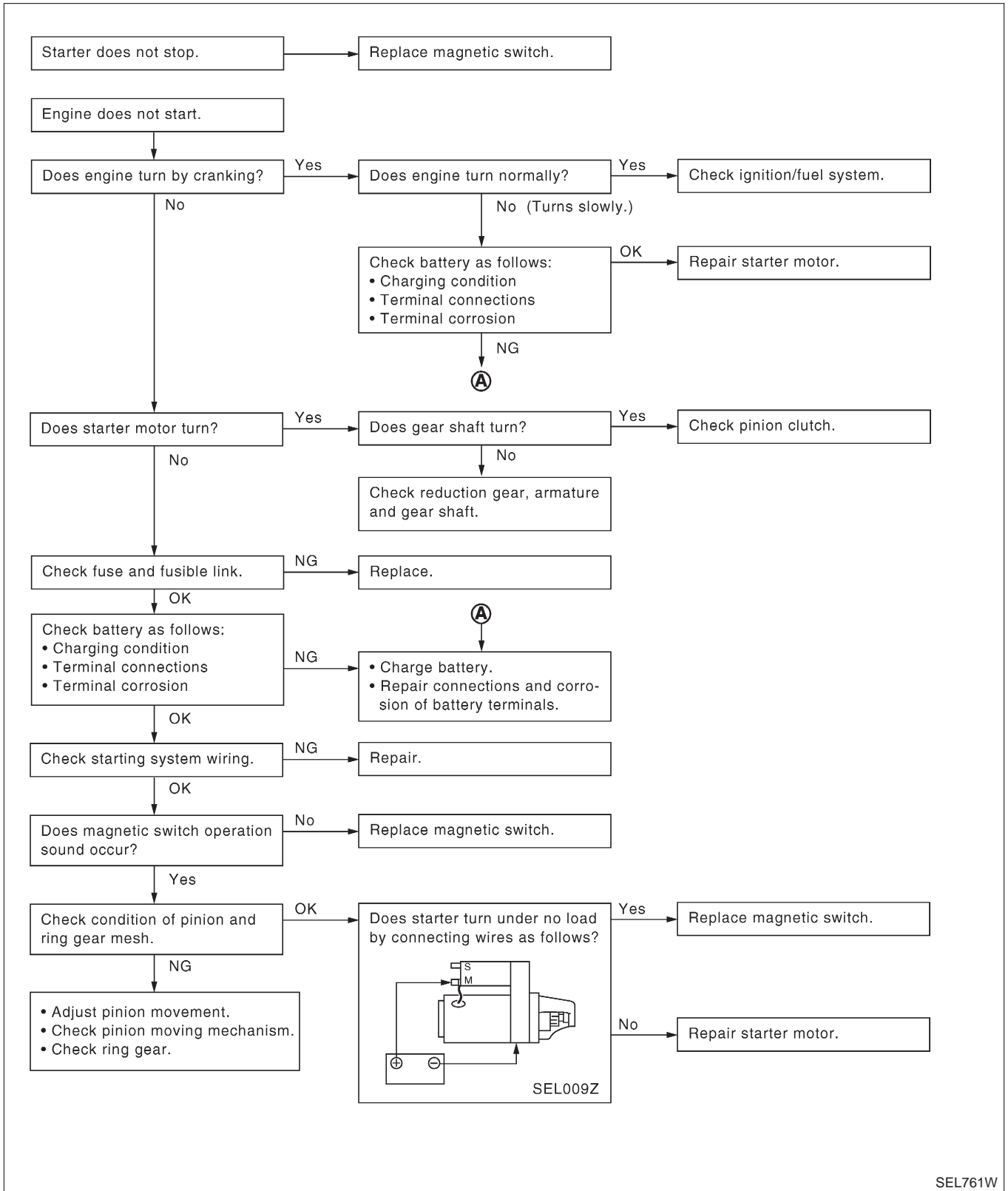

Construction

NFSC0006

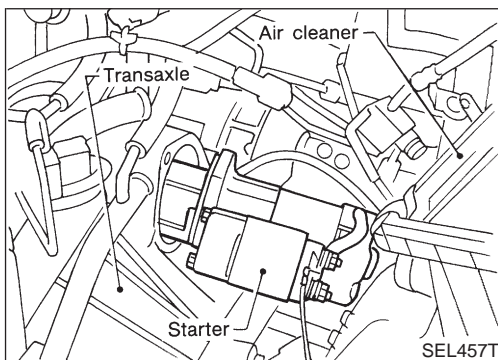
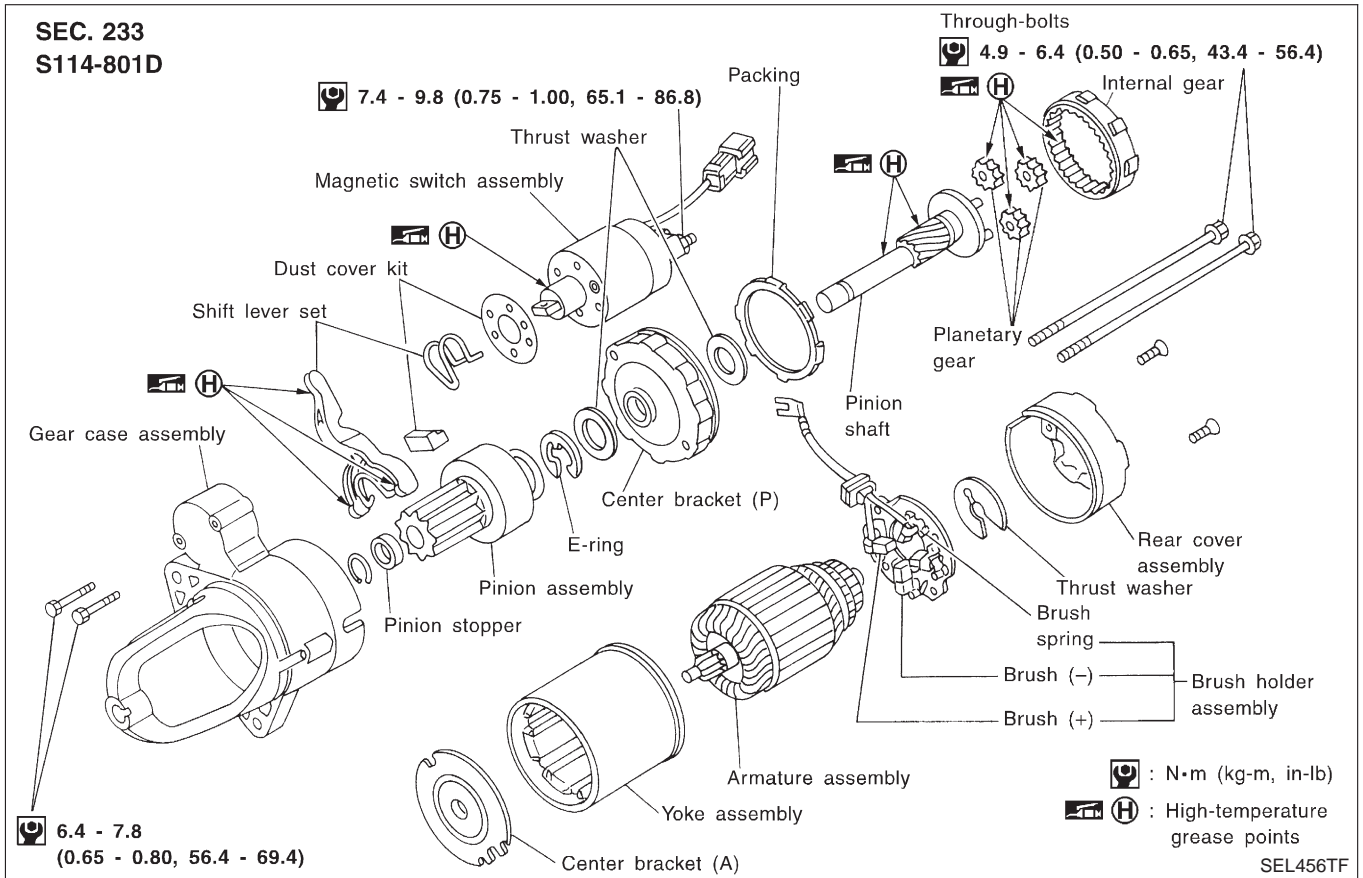

Removal and Installation

REMOVAL

1. Remove air duct assembly.
2. Remove harness protector from engine room harness.
3. Disconnect starter harness.
4. Remove starter bolts (two).
5. Remove starter.

NFSC0007

NFSC0007S01

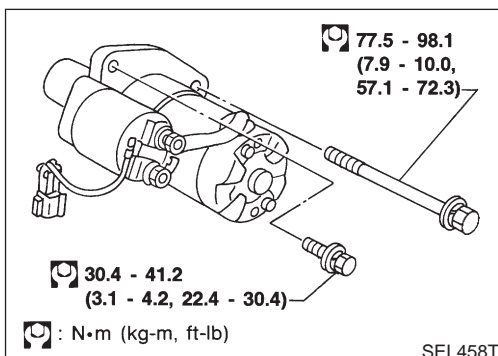

INSTALLATION

To install, reverse the removal procedure.

NFSC0007S02

STARTING SYSTEM

Inspection

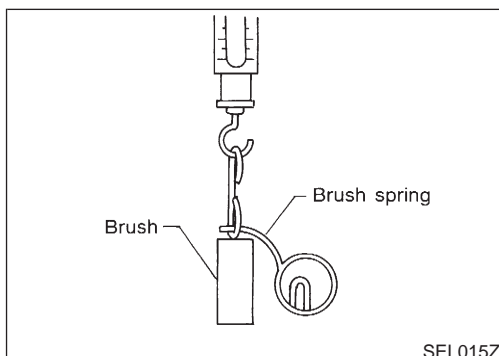
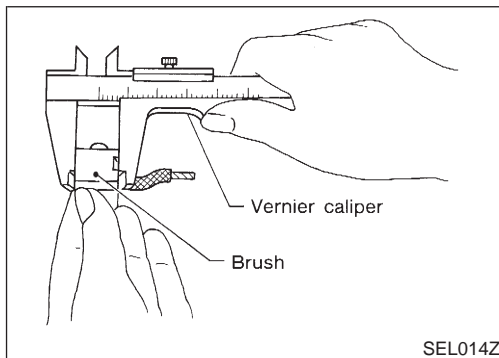
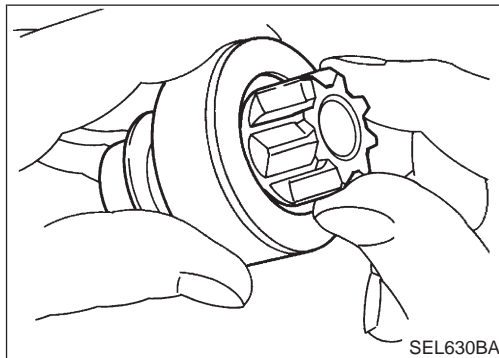
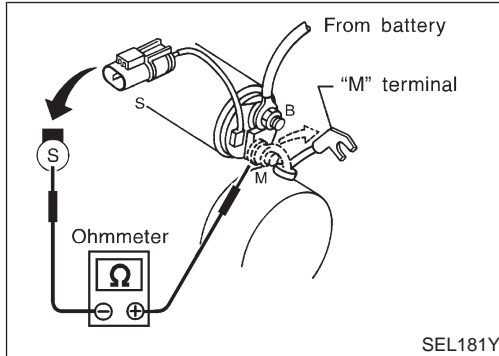
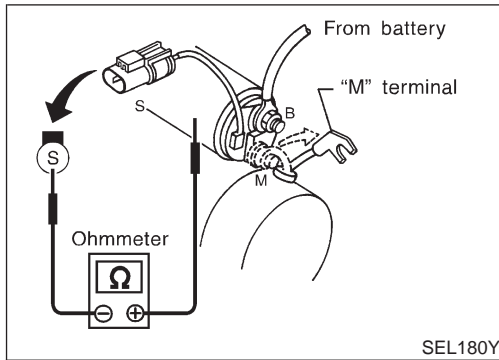

Inspection

MAGNETIC SWITCH CHECK

NFSC0019

NFSC0019S01

- Before starting to check, disconnect battery ground cable.
 - Disconnect "M" terminal of starter motor.
1. Continuity test (between "S" terminal and switch body).
 - No continuity ... Replace.
2. Continuity test (between "S" terminal and "M" terminal).
 - No continuity ... Replace.

PINION/CLUTCH CHECK

NFSC0019S02

1. Inspect pinion teeth.
 - Replace pinion if teeth are worn or damaged. (Also check condition of ring gear teeth.)
2. Inspect reduction gear teeth (If equipped).
 - Replace reduction gear if teeth are worn or damaged. (Also check condition of armature shaft gear teeth.)
3. Check to see if pinion locks in one direction and rotates smoothly in the opposite direction.
 - If it locks or rotates in both directions, or unusual resistance is evident. ... Replace.

BRUSH CHECK

NFSC0019S03

Brush

NFSC0019S0301

Check wear of brush.

Wear limit length:
Refer to SDS (SC-25).

- Excessive wear ... Replace.

Brush Spring Check

NFSC0019S0302

Check brush spring pressure with brush spring detached from brush.

Spring pressure (with new brush):
Refer to SDS (SC-25).

- Not within the specified values ... Replace.

STARTING SYSTEM

Inspection (Cont'd)

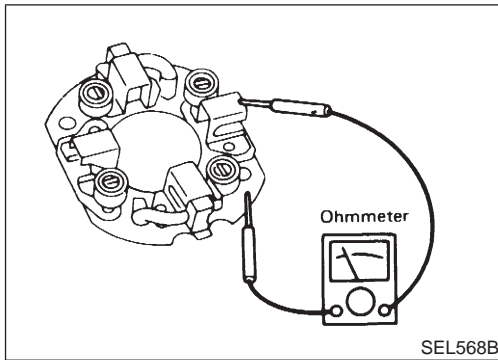

Brush Holder

1. Perform insulation test between brush holder (positive side) and its base (negative side).
 - Continuity exists. ... Replace.
2. Check brush to see if it moves smoothly.
 - If brush holder is bent, replace it; if sliding surface is dirty, clean.

NFSC0019S0303

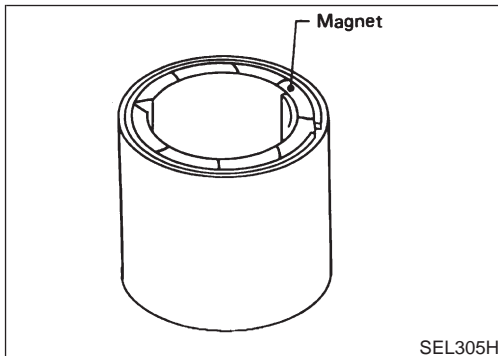

YOKE CHECK

Magnet is secured to yoke by bonding agent. Check magnet to see that it is secured to yoke and for any cracks. Replace malfunctioning parts as an assembly.

NFSC0019S04

CAUTION:

Do not clamp yoke in a vice or strike it with a hammer.

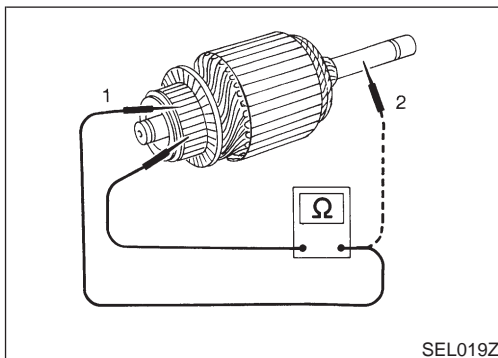

ARMATURE CHECK

1. Continuity test (between two segments side by side).
 - No continuity ... Replace.
2. Insulation test (between each commutator bar and shaft).
 - Continuity exists. ... Replace.

NFSC0019S05

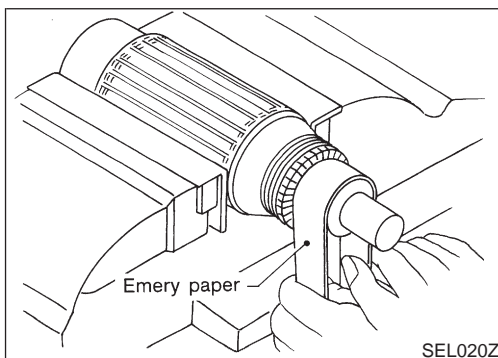

3. Check commutator surface.
 - Rough ... Sand lightly with No. 500 - 600 emery paper.

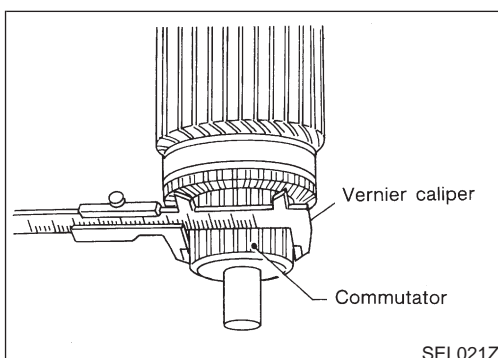

4. Check diameter of commutator.
 - **Commutator minimum diameter:**
Refer to SDS (SC-25).
 - Less than specified value ... Replace.

STARTING SYSTEM

Inspection (Cont'd)

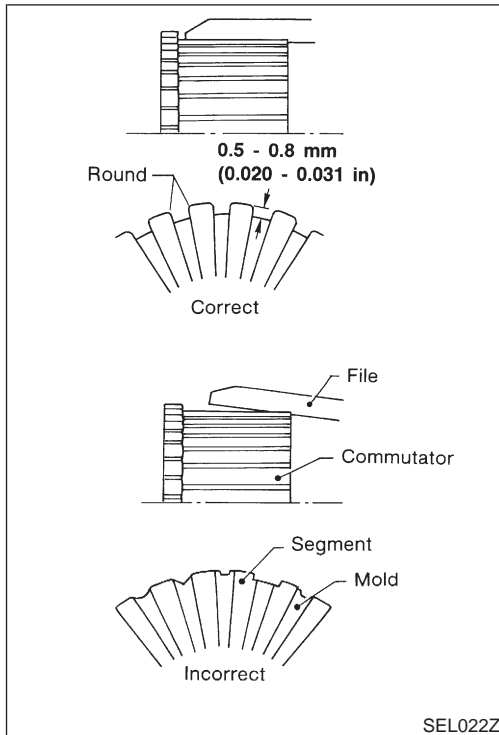

5. Check depth of insulating mold from commutator surface.
 - Less than 0.2 mm (0.008 in) ... Undercut to 0.5 to 0.8 mm (0.020 to 0.031 in)

Assembly

Apply high-temperature grease to lubricate the bearing, gears and frictional surface when assembling the starter. Carefully observe the following instructions.

NFSC0020

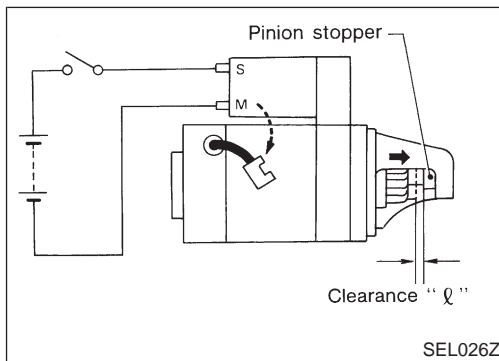

PINION PROTRUSION LENGTH ADJUSTMENT

NFSC0020S01

Clearance

NFSC0020S0101

With pinion driven out by magnetic switch, push pinion back to remove slack and measure clearance "l" between the front edge of the pinion and the pinion stopper.

Clearance "l":

Refer to SDS (SC-25).

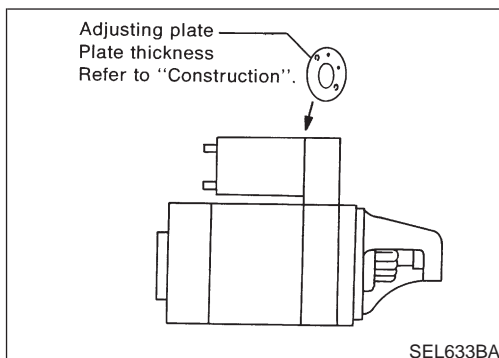

- Not in the specified value ... Adjust by adjusting plate.

System Description

NFSC0009

The alternator provides DC voltage to operate the vehicle's electrical system and to keep the battery charged. The voltage output is controlled by the IC regulator.

Power is supplied at all times to alternator terminal 3 (S) through:

- 120A fusible link (letter **A**, located in the fuse and fusible link box), and
- 10A fuse (No. 70, located in the fuse and fusible link box).

Terminal B supplies power to charge the battery and operate the vehicle's electrical system. Output voltage is controlled by the IC regulator at terminal 3 (S) detecting the input voltage. The charging circuit is protected by the 120A fusible link.

The alternator is grounded to the engine block.

With the ignition switch in the ON or START position, power is supplied

- through 10A fuse [No. 30, located in the fuse block (J/B)]
- to combination meter terminal 24 for the charge warning lamp.

Ground is supplied to terminal 68 of the combination meter through terminal 2 (L) of the alternator. With power and ground supplied, the charge warning lamp will illuminate. When the alternator is providing sufficient voltage with the engine running, the ground is opened and the charge warning lamp will go off.

If the charge warning lamp illuminates with the engine running, a fault is indicated.

CHARGING SYSTEM

Wiring Diagram — CHARGE —

Wiring Diagram — CHARGE —

NFSC0010

SC-CHARGE-01

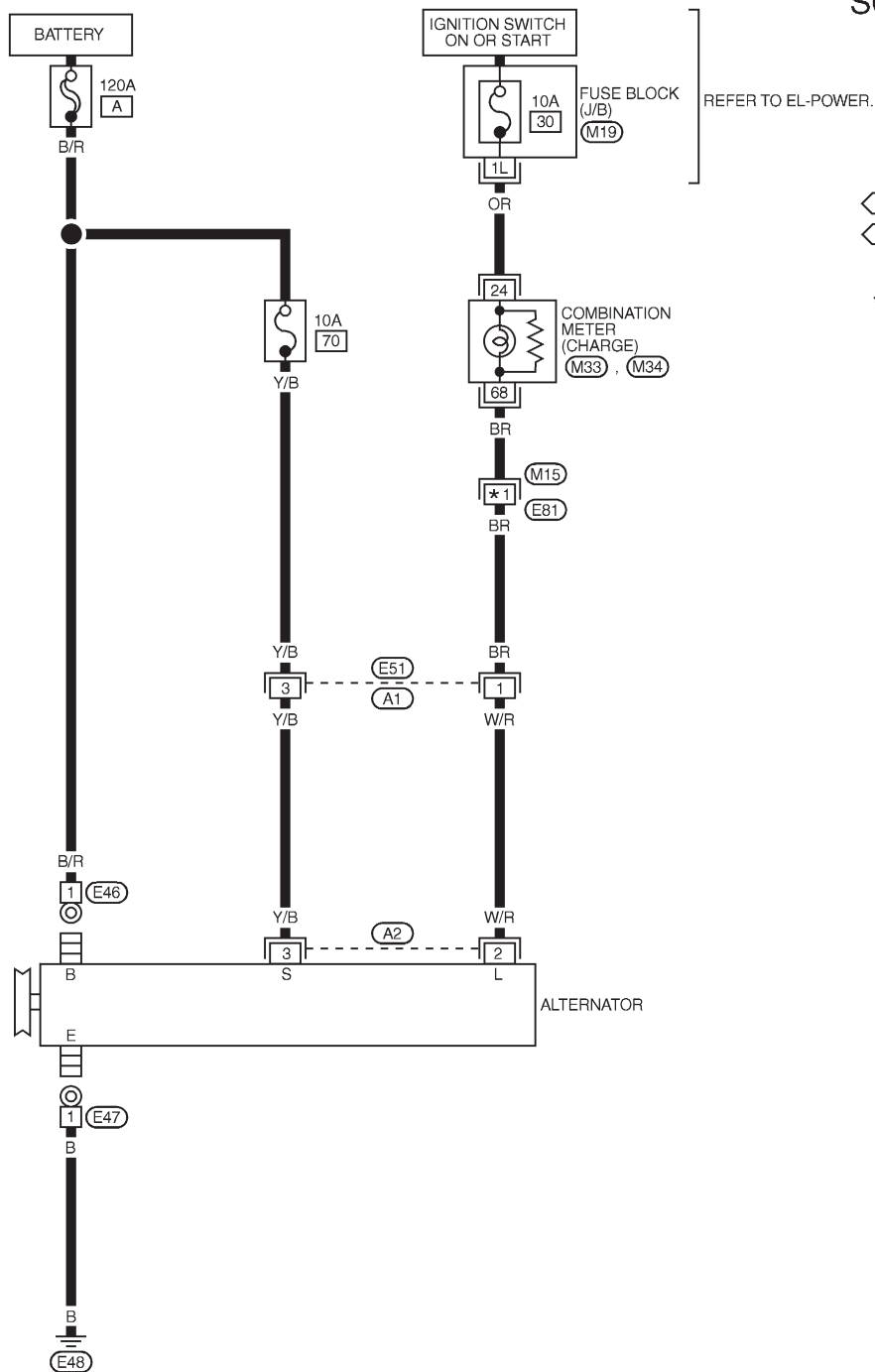

- ⬭ : LHD MODELS
- ⬮ : RHD MODELS
- * 1 6C : ⬭
- 6B : ⬮

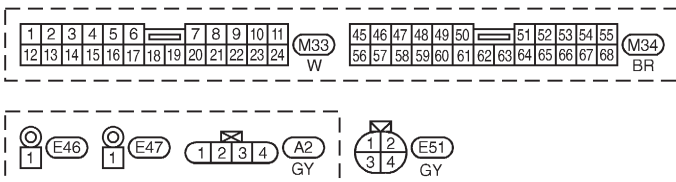

REFER TO THE FOLLOWING.
 (M15) -SUPER
 MULTIPLE JUNCTION(SMJ)
 (M19) -FUSE BLOCK-
 JUNCTION BOX(J/B)

MEL890K

CHARGING SYSTEM

Trouble Diagnoses

Trouble Diagnoses

NFSC0011

Before conducting an alternator test, make sure that the battery is fully charged. A 30-volt voltmeter and suitable test probes are necessary for the test. The alternator can be checked easily by referring to the Inspection Table.

- Before starting, inspect the fusible link.
- Use fully charged battery.

WITH IC REGULATOR

NFSC0011S01

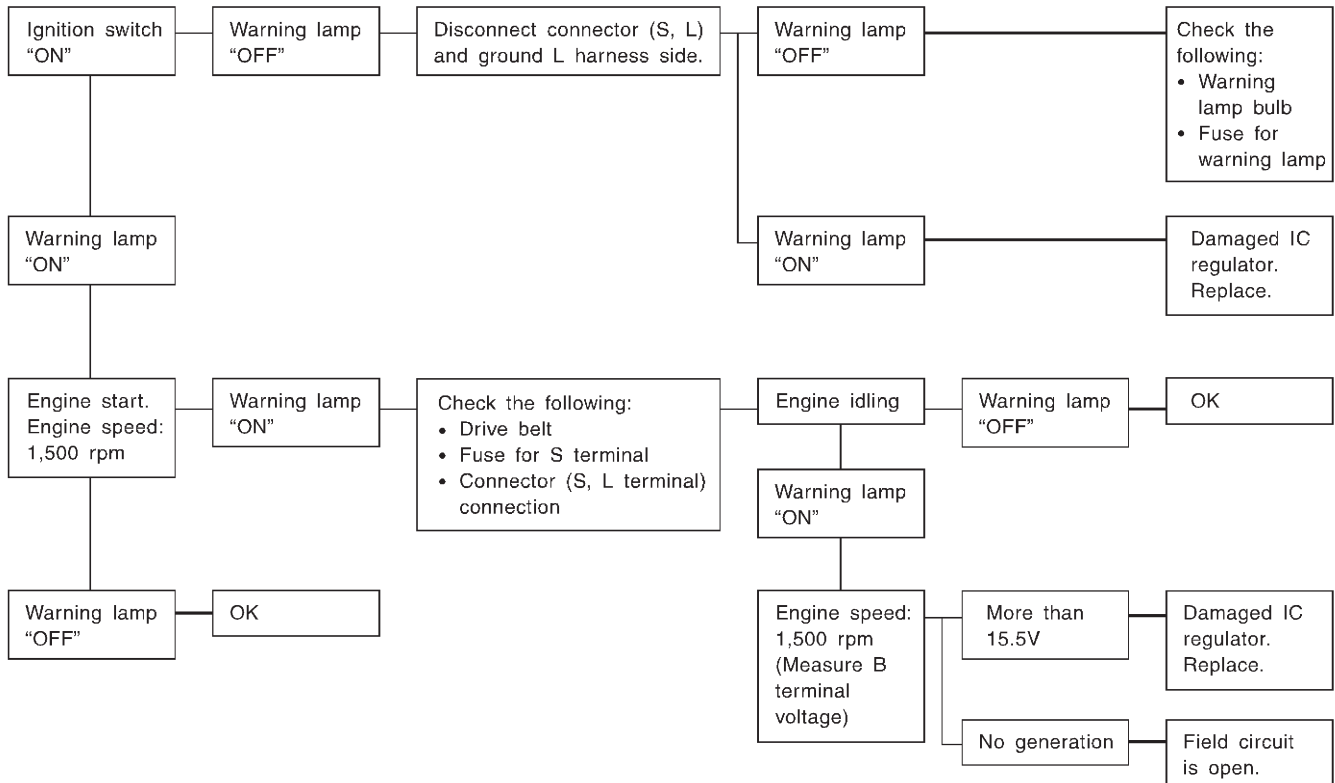

Warning lamp: "CHARGE" warning lamp in combination meter

SEL338V

NOTE:

- If the inspection result is OK even though the charging system is malfunctioning, check the B terminal connection. (Check the tightening torque.)
- When field circuit is open, check condition of rotor coil, rotor slip ring and brush. If necessary, replace faulty parts with new ones.

MALFUNCTION INDICATOR

NFSC0011S02

The IC regulator warning function activates to illuminate "CHARGE" warning lamp, if any of the following symptoms occur while alternator is operating:

- Excessive voltage is produced.
- No voltage is produced.

CHARGING SYSTEM

Construction

Construction

NFSC0012

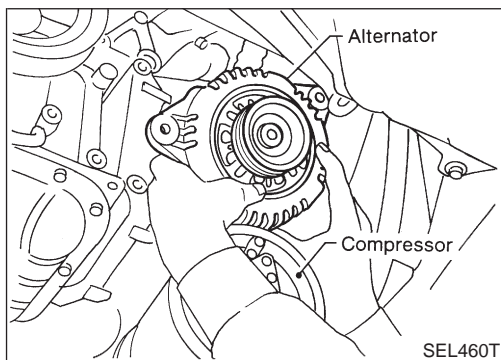
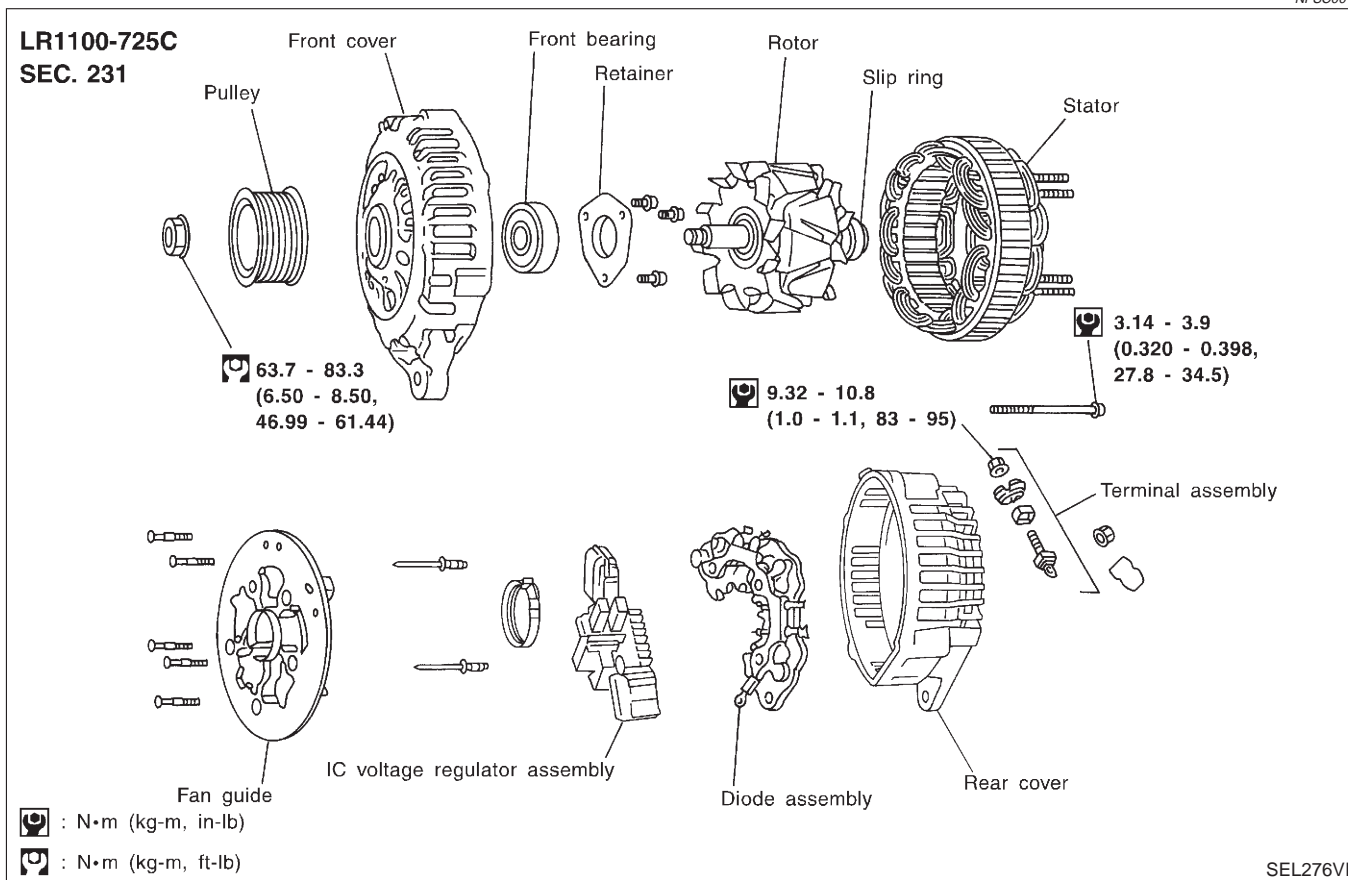

Removal and Installation

REMOVAL

1. Remove engine undercover RH.
2. Remove side inspection cover RH.
3. Loosen belt idler pulley.
4. Remove drive belt.
5. Remove A/C compressor mounting bolts (four).
6. Slide A/C compressor forward.
7. Disconnect alternator harness connector.
8. Remove alternator upper bolt and lower bolt.

NFSC0013

NFSC0013S01

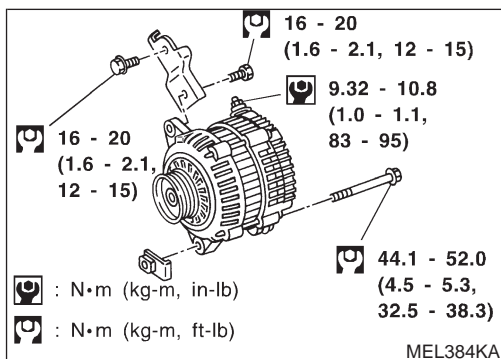

INSTALLATION

To install, reverse the removal procedure.

NFSC0013S02

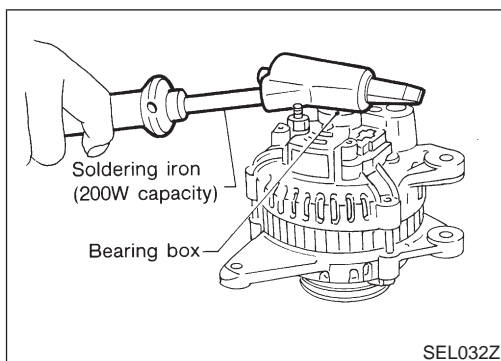

Disassembly

REAR COVER

NFSC0021

NFSC0021S01

CAUTION:

Rear cover may be hard to remove because a ring is used to lock outer race of rear bearing. To facilitate removal of rear cover, heat just bearing box section with a 200W soldering iron.

Do not use a heat gun, as it can damage diode assembly.

REAR BEARING

NFSC0021S02

CAUTION:

- Do not reuse rear bearing after removal. Replace with a new one.
- Do not lubricate rear bearing outer race.

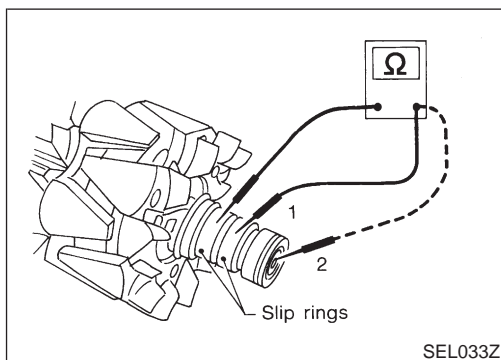

Inspection

ROTOR CHECK

NFSC0022

NFSC0022S01

1. Resistance test

Resistance: Refer to SDS (SC-25).

- Not within the specified values ... Replace rotor.
2. Insulator test
 - Continuity exists ... Replace rotor.
 3. Check slip ring for wear.

Slip ring minimum outer diameter:

Refer to SDS (SC-25).

- Not within the specified values ... Replace rotor.

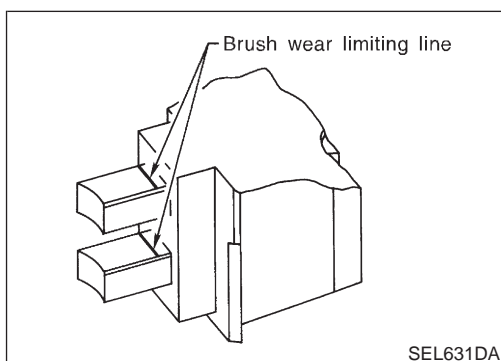

BRUSH CHECK

NFSC0022S02

1. Check smooth movement of brush.
 - Not smooth ... Check brush holder and clean.
2. Check brush for wear.
 - Replace brush if it is worn down to the limit line.

CHARGING SYSTEM

Inspection (Cont'd)

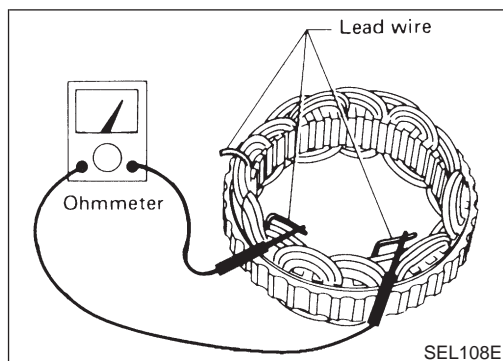

STATOR CHECK

NFSC0022S03

1. Continuity test
 - No continuity ... Replace stator.

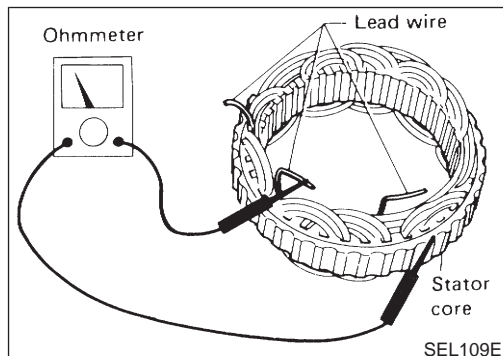

2. Ground test
 - Continuity exists ... Replace stator.

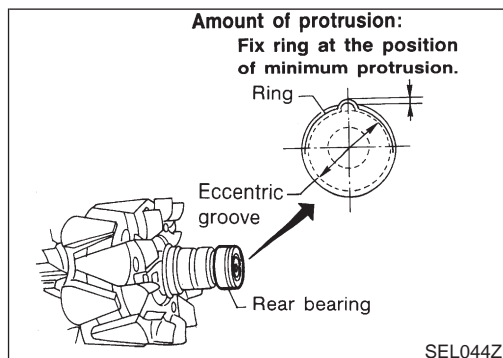

Assembly

NFSC0023

RING FITTING IN REAR BEARING

NFSC0023S01

- Fix ring into groove in rear bearing so that it is as close to the adjacent area as possible.

CAUTION:

Do not reuse rear bearing after removal.

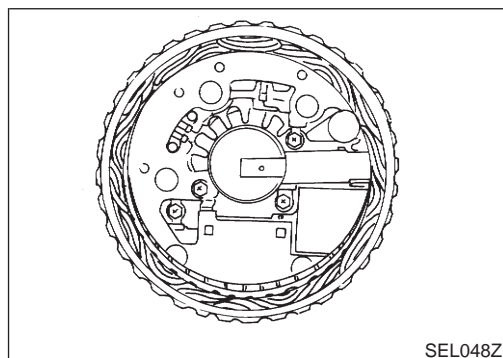

REAR COVER INSTALLATION

NFSC0023S02

1. Fit brush assembly, diode assembly, regulator assembly and stator.
2. Push brushes up with fingers and install them to rotor.

Take care not to damage slip ring sliding surface.

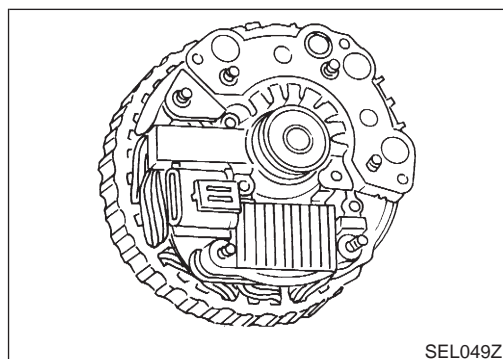

SERVICE DATA AND SPECIFICATIONS (SDS)

Battery

Battery

NFSC0014

Applied model	VQ20DE		VQ30DE	
	Europe and except for Europe		For Europe	
Type	55D23L	65D26L	80D26L	
Capacity V-AH	12-48	12 - 52	12 - 55	

Starter

NFSC0015

Type		S114-801D
		HITACHI make
		Reduction gear type
System voltage		12V
No-load	Terminal voltage	11.0V
	Current	Less than 90A
	Revolution	More than 2,700 rpm
Minimum diameter of commutator		28.0 mm (1.102 in)
Minimum length of brush		10.5 mm (0.413 in)
Brush spring tension		12.7 - 17.7 N (1.3 - 1.8 kg, 2.9 - 4.0 lb)
Clearance "ℓ" between pinion front edge and pinion stopper		0.3 - 2.5 mm (0.012 - 0.098 in)

Alternator

NFSC0016

Type		LR1100-725C
		HITACHI make
Nominal rating		12V-110A
Ground polarity		Negative
Minimum revolution under no-load (When 13.5V is applied)		Less than 950 rpm
Hot output current (When 13.5V is applied)		More than 33A/1,300 rpm More than 81A/2,500 rpm More than 93A/5,000 rpm
Regulated output voltage		14.1 - 14.7V
Minimum length of brush		More than 6.00 mm (0.2362 in)
Brush spring pressure		1.000 - 3.432 N (102 - 350 g, 3.60 - 12.34 oz)
Slip ring minimum outer diameter		More than 26.0 mm (1.024 in)
Rotor (Field coil) resistance		2.31Ω

SERVICE DATA AND SPECIFICATIONS (SDS)

Alternator (Cont'd)
