

SECTION EI
EXTERIOR & INTERIOR

A
B
C
D
E
F
G
H
EI
J
K
L
M

CONTENTS

PRECAUTIONS	3	FRONT FENDER PROTECTOR	21
Precautions for Supplemental Restraint System (SRS) "AIR BAG" and "SEAT BELT PRE-TENSIONER"	3	Removal and Installation	21
Precautions	3	FRONT	21
PREPARATION	4	REAR	22
Special Service Tools	4	MUDGUARD	23
Commercial Service Tools	4	Removal and Installation	23
SQUEAK AND RATTLE TROUBLE DIAGNOSIS	5	LICENSE LAMP FINISHER	24
Work Flow	5	Removal and Installation	24
CUSTOMER INTERVIEW	5	REAR AIR SPOILER	25
DUPLICATE THE NOISE AND TEST DRIVE	6	Removal and Installation	25
CHECK RELATED SERVICE BULLETINS	6	ROOF SIDE MOLDING	26
LOCATE THE NOISE AND IDENTIFY THE ROOT CAUSE	6	Removal and Installation	26
REPAIR THE CAUSE	6	REAR PILLAR FINISHER	27
CONFIRM THE REPAIR	7	Removal and Installation	27
Generic Squeak and Rattle Troubleshooting	7	DOOR OUTSIDE MOLDING	28
INSTRUMENT PANEL	7	Removal and Installation	28
CENTER CONSOLE	7	FRONT DOOR OUTSIDE MOLDING	28
DOORS	7	REAR DOOR OUTSIDE MOLDING	28
TRUNK	8	SIDE GUARD MOLDING	29
SUNROOF/HEADLINER	8	Removal and Installation	29
SEATS	8	REMOVAL	29
UNDERHOOD	8	INSTALLATION	29
Diagnostic Worksheet	9	DOOR FINISHER	30
CLIP AND FASTENER	11	Removal and Installation	30
Description	11	FRONT DOOR	30
FRONT BUMPER	14	REAR DOOR	31
Removal and Installation	14	BODY SIDE TRIM	32
REAR BUMPER	16	Removal and Installation	32
Removal and Installation	16	CENTER PILLAR LOWER GARNISH	33
FRONT GRILLE	18	CENTER PILLAR UPPER GARNISH	33
Removal and Installation	18	REAR PILLAR FINISHER	33
COWL TOP	19	DASH SIDE FINISHER	33
Removal and Installation	19	REAR PARCEL SHELF FINISHER	34
FRONT FENDER	20	Removal and Installation	34
Removal and Installation	20	SUNSHADE	35
		Component Parts and Harness Connector Location	35
		Wiring Diagram —SHADE—	36
		Removal and Installation	38
		FLOOR TRIM	39
		Removal and Installation	39

HEADLINING	40	TRUNK ROOM TRIM & TRUNK LID FINISHER	42
Removal and Installation	40	Removal and Installation	42

PRECAUTIONS

PRECAUTIONS

PF0:00001

Precautions for Supplemental Restraint System (SRS) “AIR BAG” and “SEAT BELT PRE-TENSIONER”

EIS001K3

The Supplemental Restraint System such as “AIR BAG” and “SEAT BELT PRE-TENSIONER”, used along with a front seat belt, helps to reduce the risk or severity of injury to the driver and front passenger for certain types of collision. This system includes seat belt switch inputs and dual stage front air bag modules. The SRS system uses the seat belt switches to determine the front air bag deployment, and may only deploy one front air bag, depending on the severity of a collision and whether the front occupants are belted or unbelted. Information necessary to service the system safely is included in the SRS and SB section of this Service Manual.

WARNING:

- To avoid rendering the SRS inoperative, which could increase the risk of personal injury or death in the event of a collision which would result in air bag inflation, all maintenance must be performed by an authorized NISSAN/INFINITI dealer.
- Improper maintenance, including incorrect removal and installation of the SRS, can lead to personal injury caused by unintentional activation of the system. For removal of Spiral Cable and Air Bag Module, see the SRS section.
- Do not use electrical test equipment on any circuit related to the SRS unless instructed to in this Service Manual. SRS wiring harnesses can be identified by yellow and/or orange harness connectors.

Precautions

EIS001K4

- When removing or disassembling any part, be careful not to damage or deform it. Protect parts which may get in the way with cloth.
- When removing parts with a screwdriver or other tool, protect parts by wrapping them with vinyl or tape.
- Keep removed parts protected with cloth.
- If a clip is deformed or damaged, replace it.
- If an un reusable part is removed, replace it with a new one.
- Tighten bolts and nuts firmly to the specified torque.
- After re-assembly has been completed, make sure each part functions correctly.
- Remove stains in the following way.
 - Water-soluble stains:
Dip a cloth in warm water, and squeeze tightly. After wiping the stain, wipe with a soft dry cloth.
 - Oil stain:
Dissolve a synthetic detergent in warm water (density of 2 to 3% or less), dip the cloth, then clean off the stain with the cloth. Next, dip the soft cloth in fresh water, and then squeeze it tightly. Then clean off the detergent completely. Then wipe the area with a soft dry cloth.
- Do not use any organic solvent, such as thinner or benzine.

PREPARATION

PREPARATION

PFP:00002

Special Service Tools

EIS001K5

The actual shapes of Kent-Moore tools may differ from those of special service tools illustrated here.

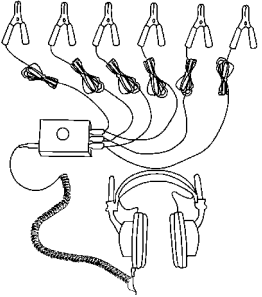
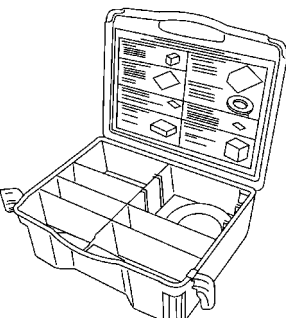
Tool number (Kent-Moore No.) Tool name	Description
(J-39570) Chassis ear <div style="text-align: center;">  <p style="text-align: right; margin-right: 50px;">SBT839</p> </div>	Locating the noise
(J-43980) NISSAN Squeak and Rattle kit <div style="text-align: center;">  <p style="text-align: right; margin-right: 50px;">SBT840</p> </div>	Repairing the cause of noise

Commercial Service Tools

EIS001K6

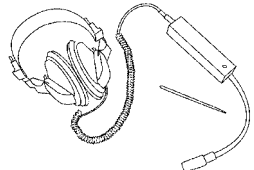
Tool name	Description
Engine ear <div style="text-align: center;">  <p style="text-align: right; margin-right: 50px;">SIIA0995E</p> </div>	Locating the noise

SQUEAK AND RATTLE TROUBLE DIAGNOSIS

SQUEAK AND RATTLE TROUBLE DIAGNOSIS

PF0:0000

Work Flow

EIS001K7

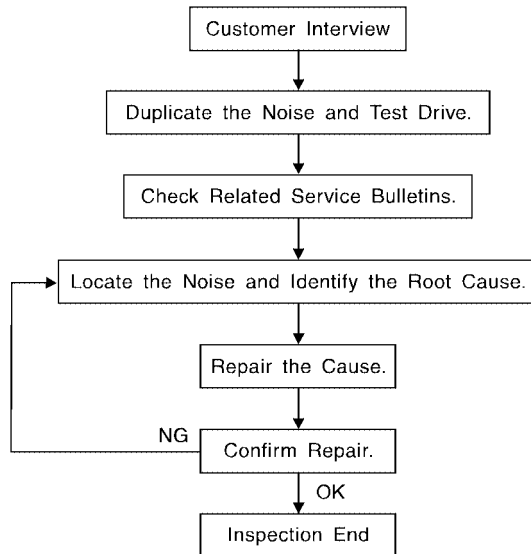

SBT842

CUSTOMER INTERVIEW

Interview the customer, if possible, to determine the conditions that exist when the noise occurs. Use the Diagnostic Worksheet during the interview to document the facts and conditions when the noise occurs and any customer's comments; refer to [EI-9, "Diagnostic Worksheet"](#). This information is necessary to duplicate the conditions that exist when the noise occurs.

- The customer may not be able to provide a detailed description or the location of the noise. Attempt to obtain all the facts and conditions that exist when the noise occurs (or does not occur).
- If there is more than one noise in the vehicle, be sure to diagnose and repair the noise that the customer is concerned about. This can be accomplished by test driving the vehicle with the customer.
- After identifying the type of noise, isolate the noise in terms of its characteristics. The noise characteristics are provided so the customer, service adviser and technician are all speaking the same language when defining the noise.
- Squeak — (Like tennis shoes on a clean floor)
Squeak characteristics include the light contact/fast movement/brought on by road conditions/hard surfaces = higher pitch noise/softer surfaces = lower pitch noises/edge to surface = chirping
- Creak — (Like walking on an old wooden floor)
Creak characteristics include firm contact/slow movement/twisting with a rotational movement/pitch dependent on materials/often brought on by activity.
- Rattle — (Like shaking a baby rattle)
Rattle characteristics include the fast repeated contact/vibration or similar movement/loose parts/missing clip or fastener/incorrect clearance.
- Knock — (Like a knock on a door)
Knock characteristics include hollow sounding/sometimes repeating/often brought on by driver action.
- Tick — (Like a clock second hand)
Tick characteristics include gentle contacting of light materials/loose components/can be caused by driver action or road conditions.
- Thump — (Heavy, muffled knock noise)
Thump characteristics include softer knock/dead sound often brought on by activity.
- Buzz — (Like a bumblebee)
Buzz characteristics include high frequency rattle/firm contact.
- Often the degree of acceptable noise level will vary depending upon the person. A noise that you may judge as acceptable may be very irritating to the customer.
- Weather conditions, especially humidity and temperature, may have a great effect on noise level.

SQUEAK AND RATTLE TROUBLE DIAGNOSIS

DUPLICATE THE NOISE AND TEST DRIVE

If possible, drive the vehicle with the customer until the noise is duplicated. Note any additional information on the Diagnostic Worksheet regarding the conditions or location of the noise. This information can be used to duplicate the same conditions when you confirm the repair.

If the noise can be duplicated easily during the test drive, to help identify the source of the noise, try to duplicate the noise with the vehicle stopped by doing one or all of the following:

- Close a door.
- Tap or push/pull around the area where the noise appears to be coming from.
- Rev the engine.
- Use a floor jack to recreate vehicle "twist".
- At idle, apply engine load (electrical load, half-clutch on M/T model, drive position on A/T model).
- Raise the vehicle on a hoist and hit a tire with a rubber hammer.
- Drive the vehicle and attempt to duplicate the conditions the customer states exist when the noise occurs.
- If it is difficult to duplicate the noise, drive the vehicle slowly on an undulating or rough road to stress the vehicle body.

CHECK RELATED SERVICE BULLETINS

After verifying the customer concern or symptom, check ASIST for Technical Service Bulletins (TSBs) related to that concern or symptom.

If a TSB relates to the symptom, follow the procedure to repair the noise.

LOCATE THE NOISE AND IDENTIFY THE ROOT CAUSE

1. Narrow down the noise to a general area. To help pinpoint the source of the noise, use a listening tool (Chassis Ear: J-39570, Engine Ear: J-39565 and mechanics stethoscope).
2. Narrow down the noise to a more specific area and identify the cause of the noise by:
 - Removing the components in the area that you suspect the noise is coming from.
Do not use too much force when removing clips and fasteners, otherwise clips and fasteners can be broken or lost during the repair, resulting in the creation of new noise.
 - Tapping or pushing/pulling the component that you suspect is causing the noise.
Do not tap or push/pull the component with excessive force, otherwise the noise will be eliminated only temporarily.
 - Feeling for a vibration with your hand by touching the component(s) that you suspect is (are) causing the noise.
 - Placing a piece of paper between components that you suspect are causing the noise.
 - Looking for loose components and contact marks.

Refer to [EI-7, "Generic Squeak and Rattle Troubleshooting"](#) .

REPAIR THE CAUSE

- If the cause is a loose component, tighten the component securely.
- If the cause is insufficient clearance between components:
 - Separate components by repositioning or loosening and retightening the component, if possible.
 - Insulate components with a suitable insulator such as urethane pads, foam blocks, felt cloth tape or urethane tape. A NISSAN Squeak and Rattle Kit (J-43980) is available through your authorized NISSAN Parts Department.

CAUTION:

Do not use excessive force as many components are constructed of plastic and may be damaged. Always check with the Parts Department for the latest parts information.

The following materials are contained in the NISSAN Squeak and Rattle Kit (J-43980). Each item can be ordered separately as needed.

URETHANE PADS [1.5 mm (0.059 in) thick]

Insulates connectors, harness, etc.

76268-9E005: 100 x 135 mm (3.94 x 5.31 in)/76884-71L01: 60 x 85 mm (2.36 x 3.35 in)/76884-71L02: 15 x 25 mm (0.59 x 0.98 in)

INSULATOR (Foam blocks)

Insulates components from contact. Can be used to fill space behind a panel.

SQUEAK AND RATTLE TROUBLE DIAGNOSIS

73982-9E000: 45 mm (1.77 in) thick, 50 x 50 mm (1.97 x 1.97 in)/73982-50Y00: 10 mm (0.39 in) thick, 50 x 50 mm (1.97 x 1.97 in)

INSULATOR (Light foam block)

80845-71L00: 30 mm (1.18 in) thick, 30 x 50 mm (1.18 x 1.97 in)

FELT CLOTH TAPE

Used to insulate where movement does not occur. Ideal for instrument panel applications.

68370-4B000: 15 x 25 mm (0.59 x 0.98 in) pad/68239-13E00: 5 mm (0.20 in) wide tape roll

The following materials, not found in the kit, can also be used to repair squeaks and rattles.

UHMW (TEFLON) TAPE

Insulates where slight movement is present. Ideal for instrument panel applications.

SILICONE GREASE

Used in place of UHMW tape that will be visible or not fit.

Note: Will only last a few months.

SILICONE SPRAY

Use when grease cannot be applied.

DUCT TAPE

Use to eliminate movement.

CONFIRM THE REPAIR

Confirm that the cause of a noise is repaired by test driving the vehicle. Operate the vehicle under the same conditions as when the noise originally occurred. Refer to the notes on the Diagnostic Worksheet.

Generic Squeak and Rattle Troubleshooting

EIS001K8

Refer to Table of Contents for specific component removal and installation information.

INSTRUMENT PANEL

Most incidents are caused by contact and movement between:

1. The cluster lid A and instrument panel
2. Acrylic lens and combination meter housing
3. Instrument panel to front pillar garnish
4. Instrument panel to windshield
5. Instrument panel mounting pins
6. Wiring harnesses behind the combination meter
7. A/C defroster duct and duct joint

These incidents can usually be located by tapping or moving the components to duplicate the noise or by pressing on the components while driving to stop the noise. Most of these incidents can be repaired by applying felt cloth tape or silicone spray (in hard to reach areas). Urethane pads can be used to insulate wiring harness.

CAUTION:

Do not use silicone spray to isolate a squeak or rattle. If you saturate the area with silicone, you will not be able to recheck the repair.

CENTER CONSOLE

Components to pay attention to include:

1. Shifter assembly cover to finisher
2. A/C control unit and upper/lower cluster lid C
3. Wiring harnesses behind audio and A/C control unit

The instrument panel repair and isolation procedures also apply to the center console.

DOORS

Pay attention to the:

1. Finisher and inner panel making a slapping noise
2. Inside handle escutcheon to door finisher
3. Wiring harnesses tapping
4. Door striker out of alignment causing a popping noise on starts and stops

SQUEAK AND RATTLE TROUBLE DIAGNOSIS

Tapping or moving the components or pressing on them while driving to duplicate the conditions can isolate many of these incidents. You can usually insulate the areas with felt cloth tape or insulator foam blocks from the NISSAN Squeak and Rattle Kit (J-43980) to repair the noise.

TRUNK

Trunk noises are often caused by a loose jack or loose items put into the trunk by the owner. In addition look for:

1. Trunk lid bumpers out of adjustment
2. Trunk lid striker out of adjustment
3. The trunk lid torsion bars knocking together
4. A loose license plate or bracket

Most of these incidents can be repaired by adjusting, securing or insulating the item(s) or component(s) causing the noise.

SUNROOF/HEADLINER

Noises in the sunroof/headliner area can often be traced to one of the following:

1. Sunroof lid, rail, linkage or seals making a rattle or light knocking noise
2. Sunvisor shaft shaking in the holder
3. Front or rear windshield touching headliner and squeaking

Again, pressing on the components to stop the noise while duplicating the conditions can isolate most of these incidents. Repairs usually consist of insulating with felt cloth tape.

SEATS

When isolating seat noises it is important to note the position the seat is in and the load placed on the seat when the noise is present. These conditions should be duplicated when verifying and isolating the cause of the noise.

Cause of seat noise include:

1. Headrest rods and holders
2. A squeak between the seat pad cushion and frame
3. The rear seat back lock and bracket

These noises can be isolated by moving or pressing on the suspected components while duplicating the conditions under which the noise occurs. Most of these incidents can be repaired by repositioning the component or applying urethane tape to the contact area.

UNDERHOOD

Some interior noises may be caused by components under the hood or on the engine wall. The noise is then transmitted into the passenger compartment.

Causes of transmitted underhood noises include:

1. Any component mounted to the engine wall
2. Components that pass through the engine wall
3. Engine wall mounts and connectors
4. Loose radiator mounting pins
5. Hood bumpers out of adjustment
6. Hood striker out of adjustment

These noises can be difficult to isolate since they cannot be reached from the interior of the vehicle. The best method is to secure, move or insulate one component at a time and test drive the vehicle. Also, engine RPM or load can be changed to isolate the noise. Repairs can usually be made by moving, adjusting, securing, or insulating the component causing the noise.

SQUEAK AND RATTLE TROUBLE DIAGNOSIS

Diagnostic Worksheet

EIS001K9



SQUEAK & RATTLE DIAGNOSTIC WORKSHEET

Dear Nissan Customer:

We are concerned about your satisfaction with your Nissan vehicle. Repairing a squeak or rattle sometimes can be very difficult. To help us fix your Nissan right the first time, please take a moment to note the area of the vehicle where the squeak or rattle occurs and under what conditions. You may be asked to take a test drive with a service advisor or technician to ensure we confirm the noise you are hearing.

I. WHERE DOES THE NOISE COME FROM? (circle the area of the vehicle)

The illustrations are for reference only, and may not reflect the actual configuration of your vehicle.

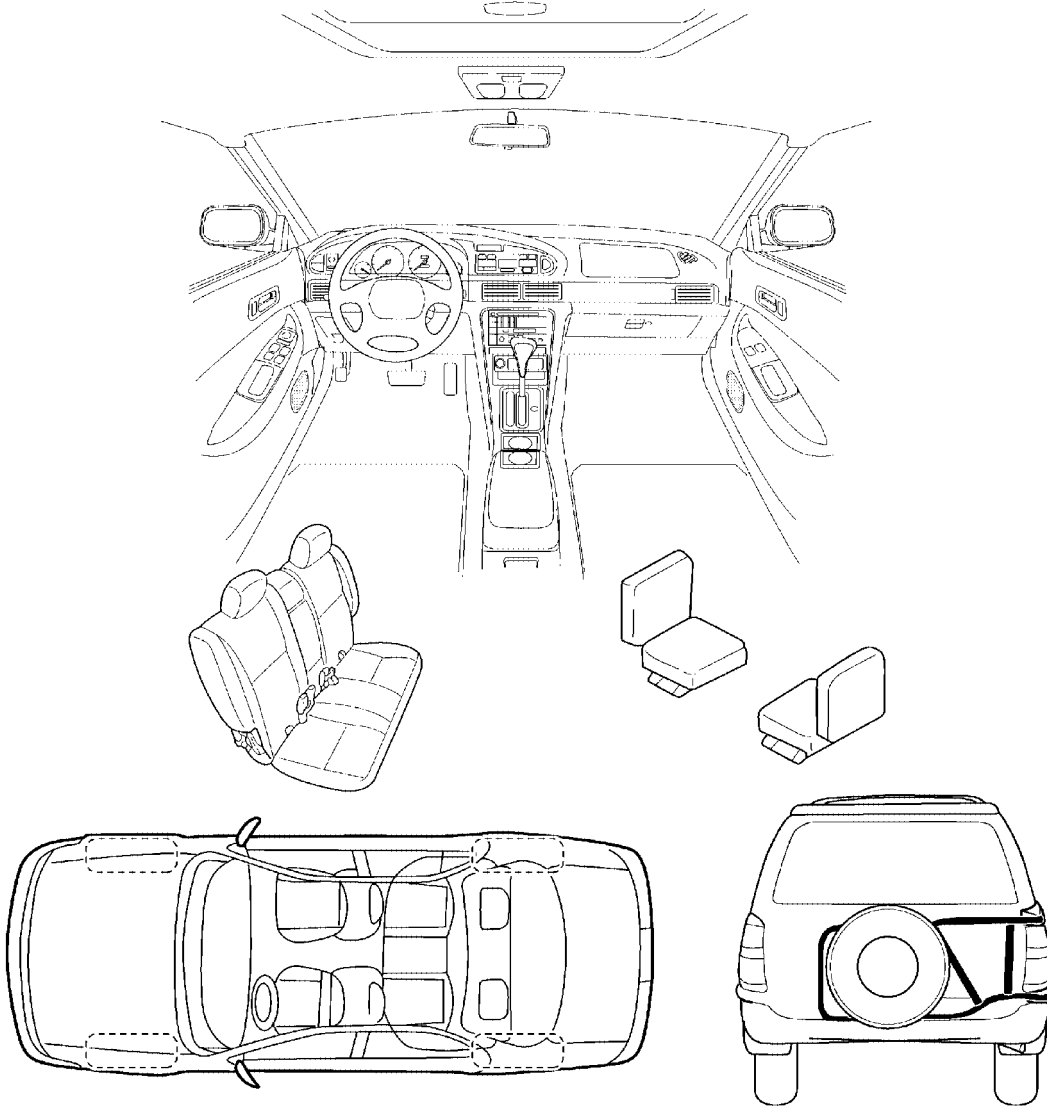

Continue to the back of the worksheet and briefly describe the location of the noise or rattle. In addition, please indicate the conditions which are present when the noise occurs.

SBT843

A
B
C
D
E
F
G
H
EI
J
K
L
M

SQUEAK AND RATTLE TROUBLE DIAGNOSIS

SQUEAK & RATTLE DIAGNOSTIC WORKSHEET- page 2

Briefly describe the location where the noise occurs:

II. WHEN DOES IT OCCUR? (check the boxes that apply)

- | | |
|--|---|
| <input type="checkbox"/> anytime | <input type="checkbox"/> after sitting out in the sun |
| <input type="checkbox"/> 1 st time in the morning | <input type="checkbox"/> when it is raining or wet |
| <input type="checkbox"/> only when it is cold outside | <input type="checkbox"/> dry or dusty conditions |
| <input type="checkbox"/> only when it is hot outside | <input type="checkbox"/> other: _____ |

III. WHEN DRIVING:

- through driveways
- over rough roads
- over speed bumps
- only at about ____ mph
- on acceleration
- coming to a stop
- on turns : left, right or either (circle)
- with passengers or cargo
- other: _____
- after driving ____ miles or ____ minutes

IV. WHAT TYPE OF NOISE?

- squeak (like tennis shoes on a clean floor)
- creak (like walking on an old wooden floor)
- rattle (like shaking a baby rattle)
- knock (like a knock on a door)
- tick (like a clock second hand)
- thump (heavy, muffled knock noise)
- buzz (like a bumble bee)

TO BE COMPLETED BY DEALERSHIP PERSONNEL

Test Drive Notes:

	<u>YES</u>	<u>NO</u>	Initials of person <u>performing</u>
Vehicle test driven with customer	<input type="checkbox"/>	<input type="checkbox"/>	_____
- Noise verified on test drive	<input type="checkbox"/>	<input type="checkbox"/>	_____
- Noise source located and repaired	<input type="checkbox"/>	<input type="checkbox"/>	_____
- Follow up test drive performed to confirm repair	<input type="checkbox"/>	<input type="checkbox"/>	_____

VIN: _____ Customer Name: _____

W.O. #: _____ Date: _____

This form must be attached to Work Order

CLIP AND FASTENER









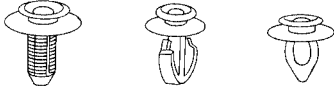
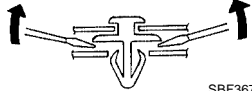

CLIP AND FASTENER

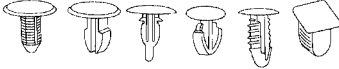
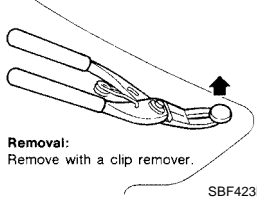
PFP:76906

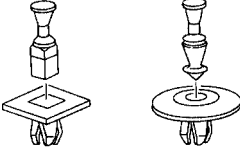
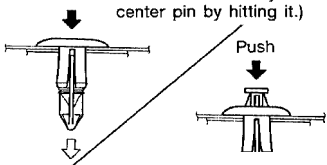
EIS001KA

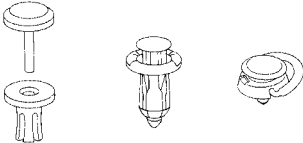
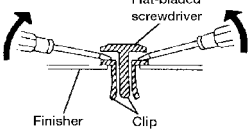

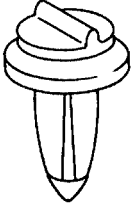
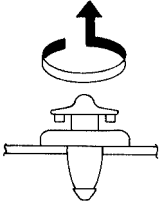

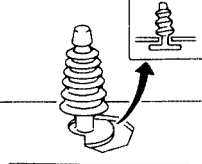
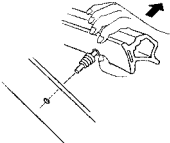

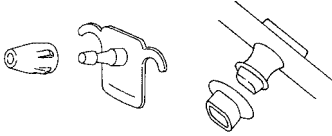
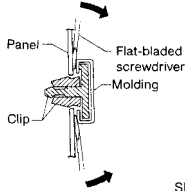

Description

- Clips and fasteners in EI section correspond to the following numbers and symbols.
- Replace any clips and/or fasteners which are damaged during removal or installation.

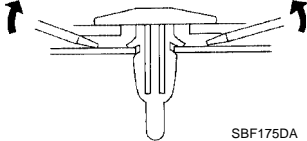

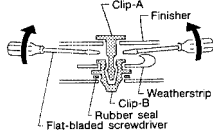
Symbol No.	Shapes	Removal & Installation
C101 	 SBF302H	Removal: Remove by bending up with flat-bladed screwdrivers or clip remover.  SBF367BA
C103 	 SBT095	 Removal: Remove with a clip remover. SBF423H
C203 	 SBF258G	 center pin by hitting it.) Push SBF708E
C205 	 MBT080A	Removal:  Flat-bladed screwdriver Finisher Clip SBF638CA
C206 	 MBF519B	 MBF520B
CE103 	 SBF104B	Removal:  SBF147B

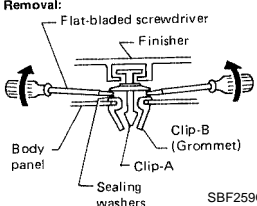
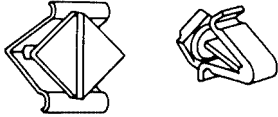
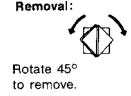
A
B
C
D
E
F
G
H
EI
J
K
L
M

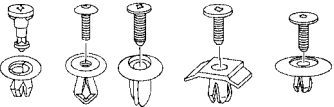
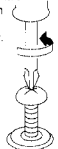
CLIP AND FASTENER

Symbol No.	Shapes	Removal & Installation
CE107	 <p style="text-align: center;">SBF411H</p>	 <p style="text-align: right;">SBF767B</p>
CE117	 <p style="text-align: center;">SBF174D</p>	<p>Removal: Remove by bending up with a flat-bladed screwdriver or pliers.</p>  <p style="text-align: right;">SBF175DA</p>
CF110	 <p style="text-align: center;">SBF648B</p>	<p>Removal:</p>  <p style="text-align: right;">SBF649B</p>
CF118	 <p style="text-align: center;">SBF151D</p>	<p>Removal:</p>  <p style="text-align: right;">SBF259G</p>
CG101	 <p style="text-align: center;">SBF145B</p>	<p>Removal:</p>  <p style="text-align: center;">Rotate 45° to remove.</p> <p>Installation:</p>  <p style="text-align: right;">SBF085B</p>
CS101	 <p style="text-align: center;">SBF078B</p>	<p>Removal:</p> <ol style="list-style-type: none"> Screw out with a Phillips screwdriver. Remove female portion with flat-bladed screwdriver.  <p style="text-align: right;">SBF992G</p>

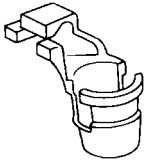
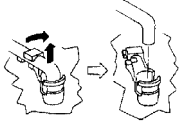
CLIP AND FASTENER

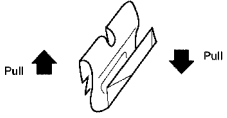
Symbol No.	Shapes	Removal & Installation
CR103	 <p style="text-align: center;">SBF768B</p>	<p>Removal: Holder portion of clip must be spread out to remove rod.</p>  <p style="text-align: right;">SBF770B</p>
Metal Clip	 <p style="text-align: center;">WBT072</p>	<p>Removal:</p>  <p style="text-align: right;">WBT073</p>

A
B
C
D
E
F
G
H
EI
J
K
L
M

EI

FRONT BUMPER

FRONT BUMPER

PFP:F2022

Removal and Installation

EIS001KB

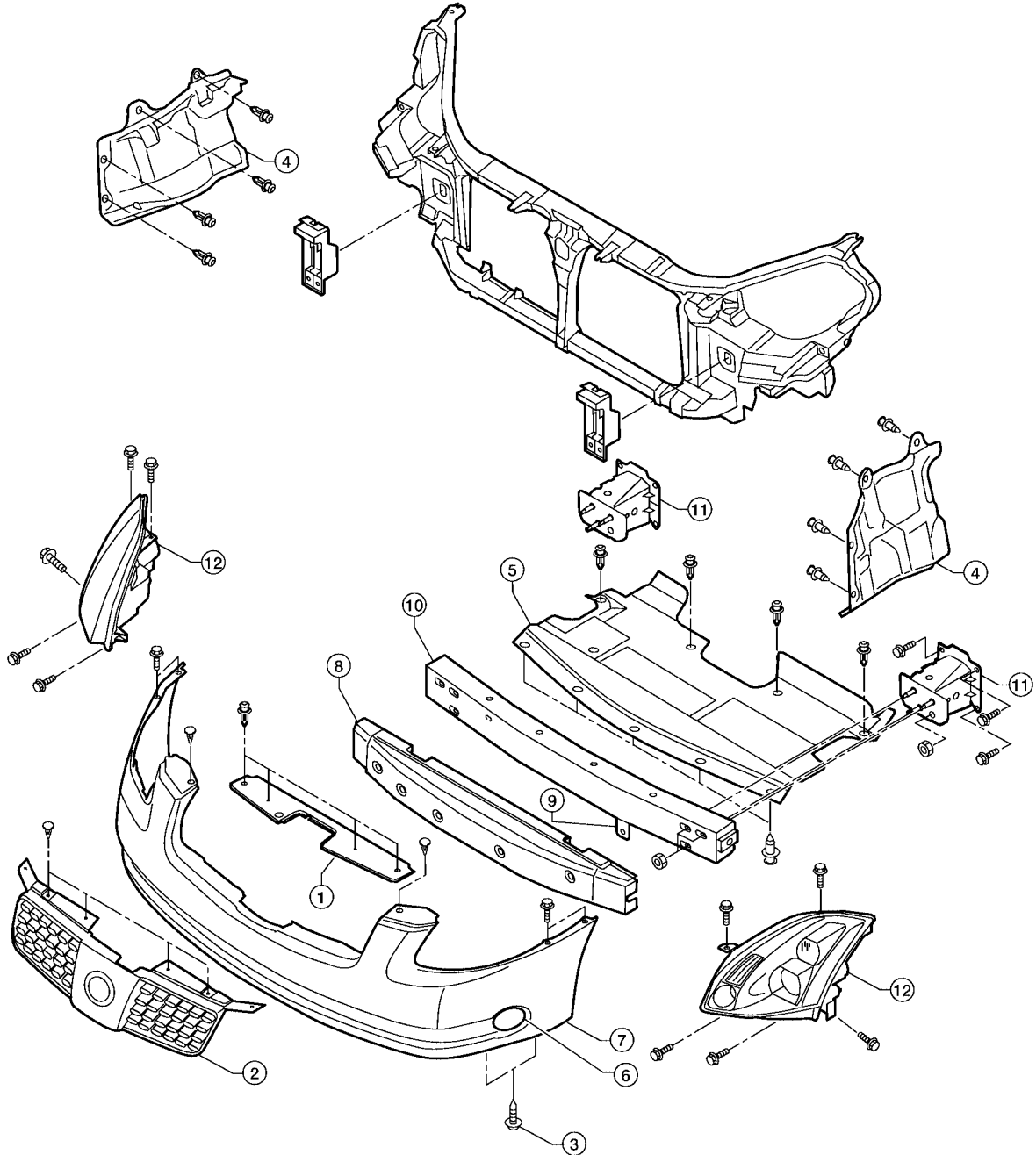

WIIA0164E

FRONT BUMPER

1. Remove grille top cover.
 2. Remove radiator grille. Refer to [EI-18, "FRONT GRILLE"](#) .
 3. Remove screws on each side of bottom of fascia that attach fascia to bottom of fender protector. Partially remove fender protector. Refer to [EI-21, "FRONT FENDER PROTECTOR"](#) .
 4. Remove engine underside covers.
 5. Remove engine front undercover.
 6. Unplug connectors to cornering lights in fascia.
 7. Remove front bumper fascia.
 8. Pull off energy absorbing foam from front bumper.
 9. Unplug ambient temperature sensor where it is attached to front bumper reinforcement.
 10. Remove front bumper reinforcement.
 11. Remove front bumper supports.
 12. Unplug harnesses and remove headlight assemblies.
- Installation is in the reverse order of removal.

A

B

C

D

E

F

G

H

EI

J

K

L

M

REAR BUMPER

REAR BUMPER

PF0:H5022

Removal and Installation

EIS001KC

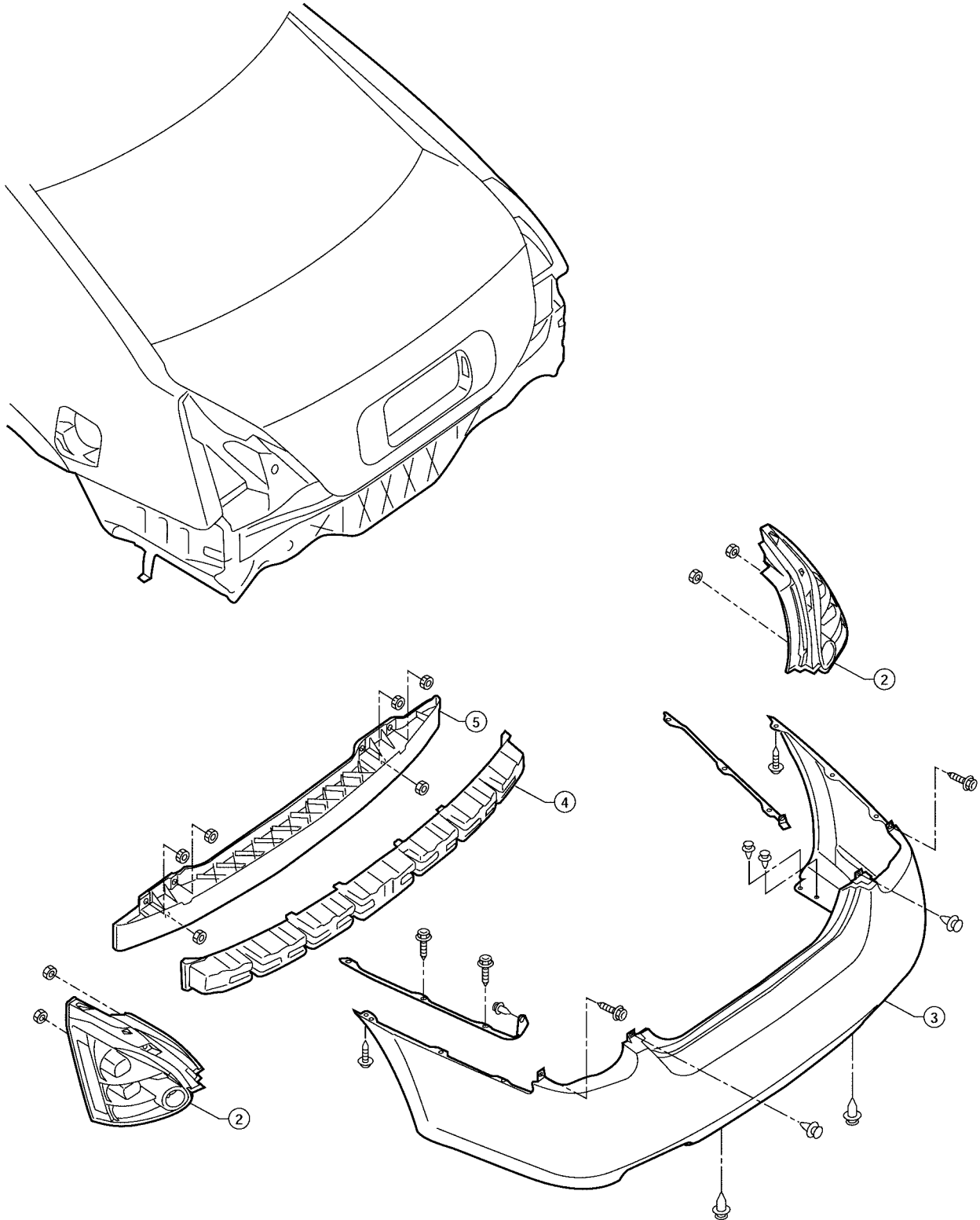

W11A0165E

REAR BUMPER

1. Remove rear trunk plate and partially remove trunk side finishers. Refer to [EI-42, "TRUNK ROOM TRIM & TRUNK LID FINISHER"](#) .
2. Remove rear combination lamps. Refer to [LT-148, "REAR COMBINATION LAMP"](#) .
3. Remove rear bumper fascia.
 - If fascia is to be replaced, remove bracket from fascia.
4. Remove energy absorber from rear bumper reinforcement.
5. Remove rear bumper reinforcement.

Installation is in the reverse order of removal.

A

B

C

D

E

F

G

H

EI

J

K

L

M

FRONT GRILLE

FRONT GRILLE

PFP:62310

Removal and Installation

EIS001KD

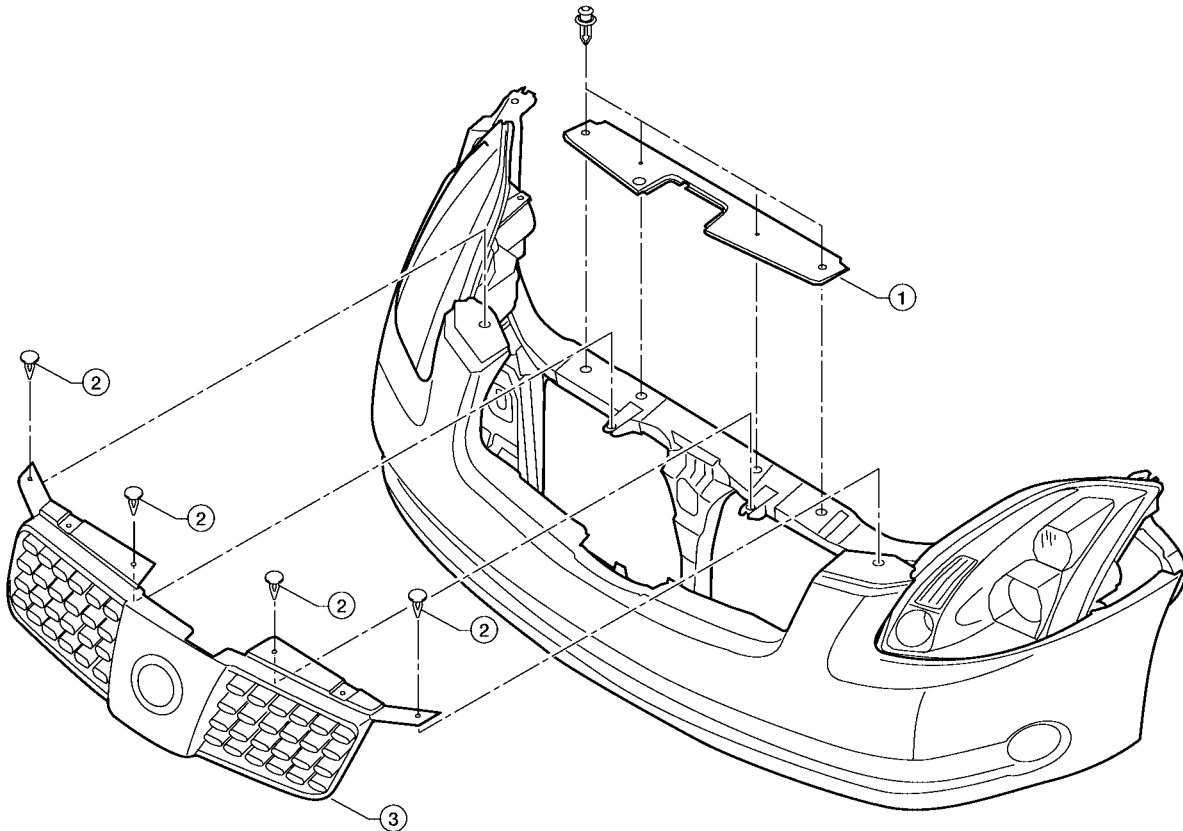

1. Remove 4 clips attaching grille top cover and remove grille top cover.
2. Remove 4 clips on top of radiator grille.
3. Remove radiator grille.
 - Pull out of 4 tabs on the bottom.

Installation is in the reverse order of removal.

WIIA0166E

COWL TOP

PFP:66100

COWL TOP

Removal and Installation

EIS001KE

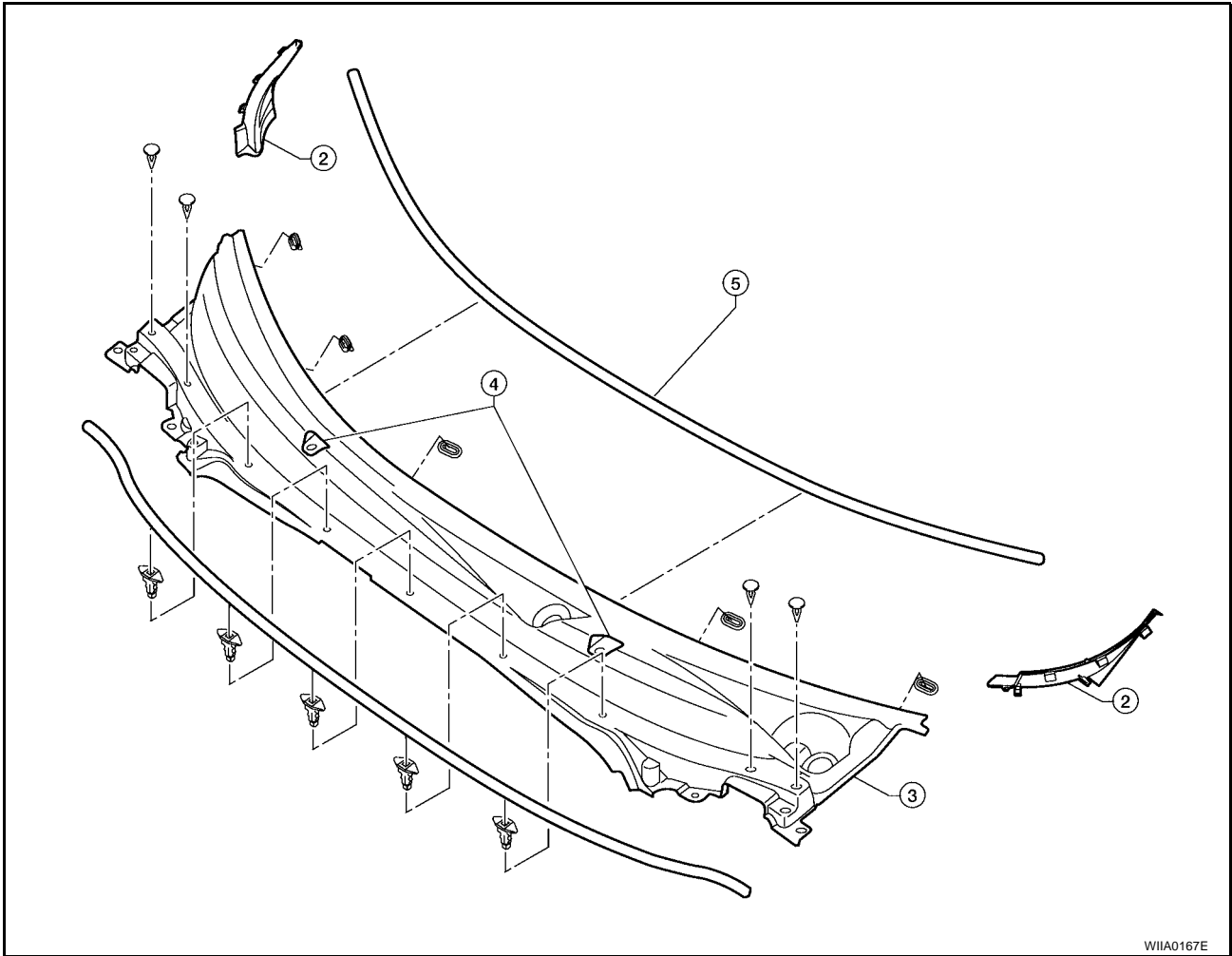

1. Remove both the right and left wiper arms from the vehicle. Refer to [WW-27, "Removal and Installation for Front Wiper Arms, Adjustment for Wiper Arms Stop Location"](#) .
 2. Remove fender covers.
 3. Remove clips attaching cowl top cover and remove cowl top cover.
 4. Disconnect windshield washer hose.
 5. Remove cowl top seal.
 6. Remove cowl weather-strip seal.
 7. Remove windshield washer nozzles and hoses from cowl. Refer to [WW-29, "Washer Tube Layout"](#) .
- Installation is in the reverse order of removal.

FRONT FENDER

FRONT FENDER

PFP:63100

Removal and Installation

EIS001KF

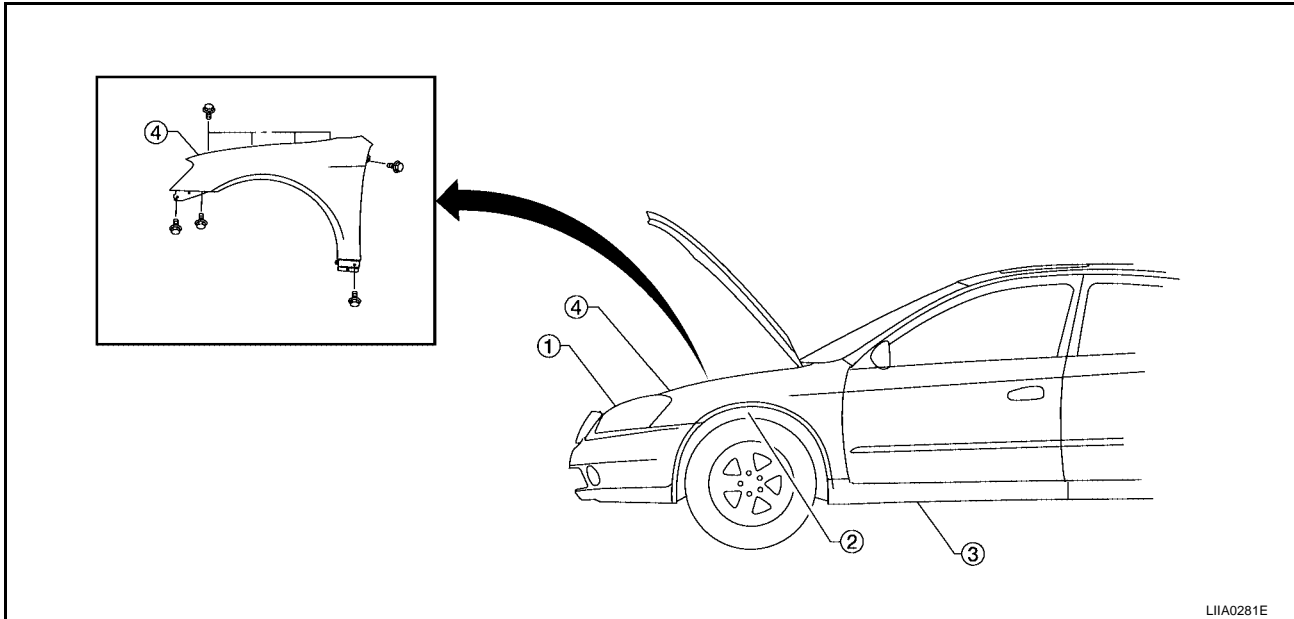

1. Remove front combination lamp. Refer to [LT-41, "Combination Lamp Removal and Installation"](#) .
2. Remove fender protector. Refer to [EI-21, "Removal and Installation"](#) .
3. Remove front half of center mud guard. Refer to [EI-23, "Removal and Installation"](#) .
4. Remove front fender.

Installation is in the reverse order of removal.

FRONT FENDER PROTECTOR

FRONT FENDER PROTECTOR

PFP:63840

Removal and Installation FRONT

EIS001KG

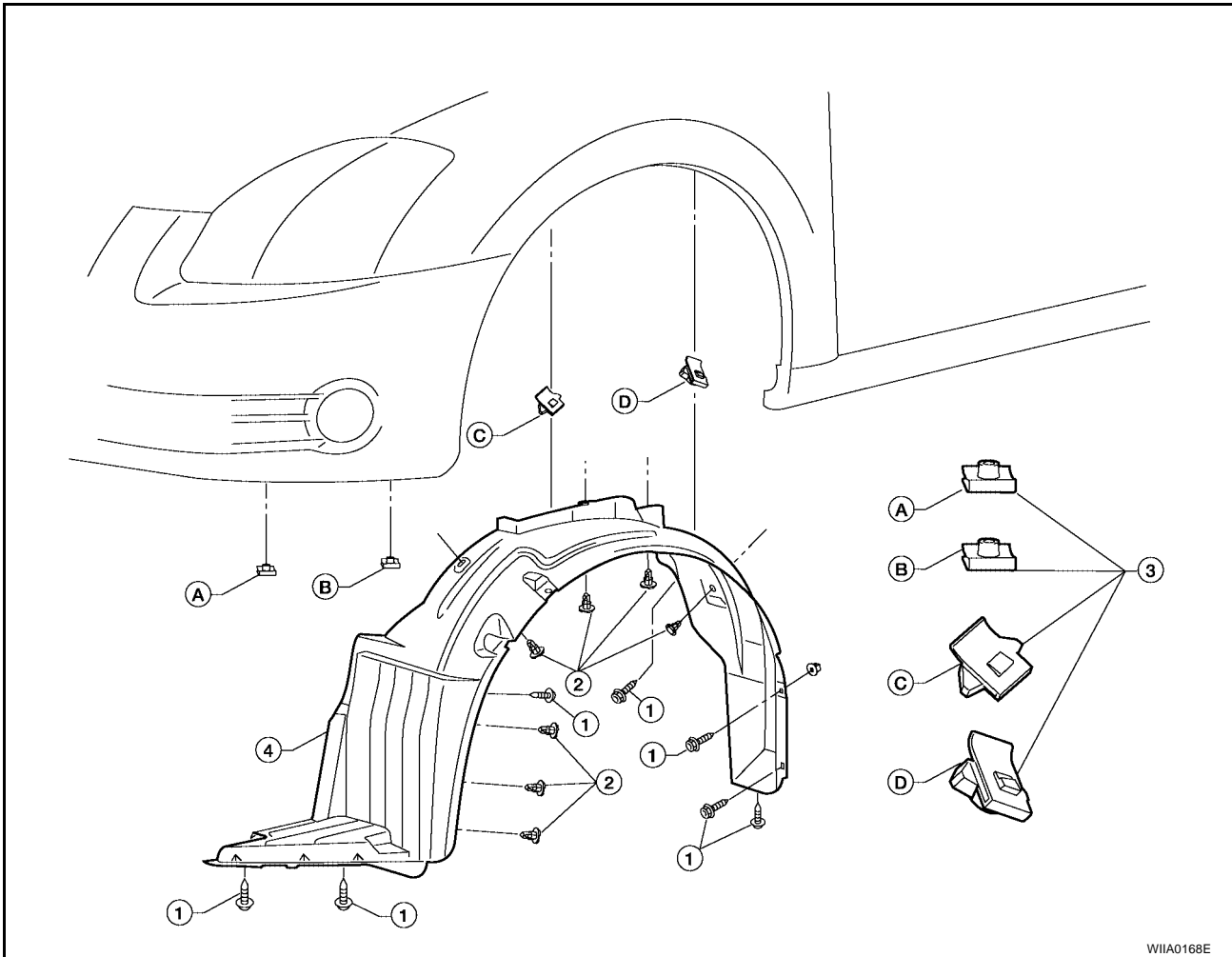

WIIA0168E

1. Remove screws.
 2. Remove pushpins.
 3. Remove clips.
 4. Remove front fender protector.
- Installation is in the reverse order of removal.

A
B
C
D
E
F
G
H
EI
J
K
L
M

FRONT FENDER PROTECTOR

REAR

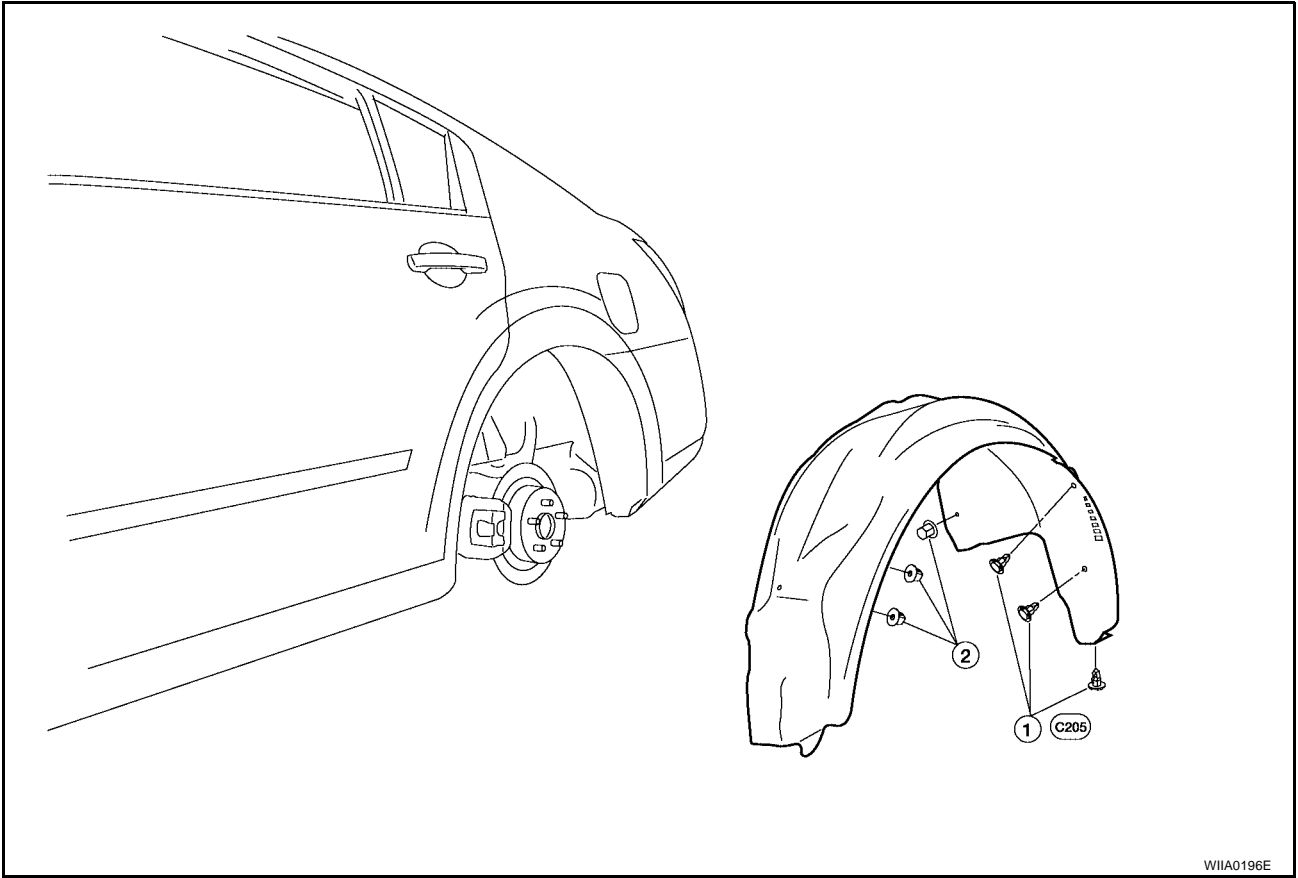

WIIA0196E

1. Remove clips.
2. Remove nuts.
3. Remove rear fender protector.

Installation is in the reverse order of removal.

MUDGUARD

MUDGUARD

PF:63854

Removal and Installation

EIS001KH

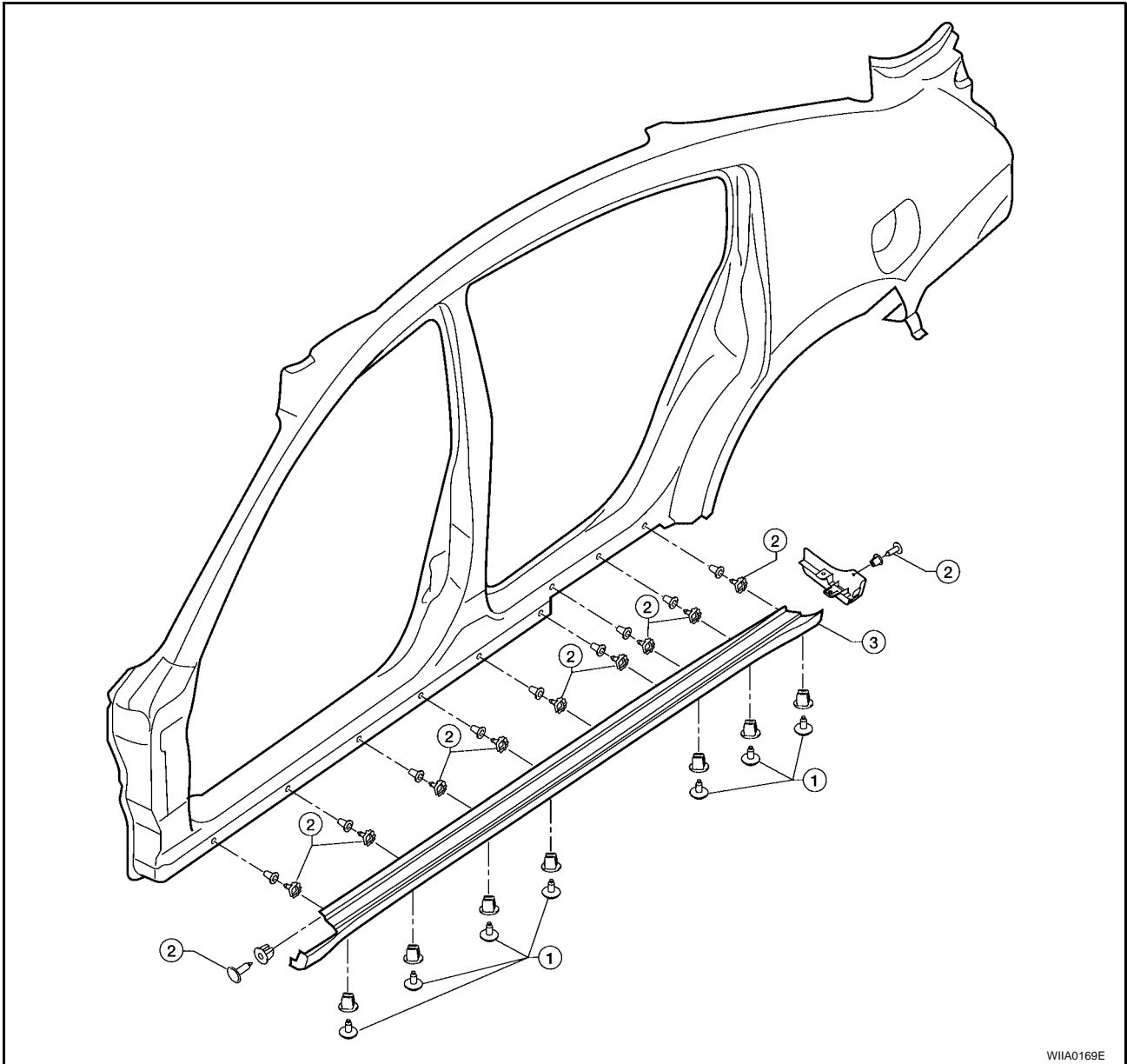

1. Remove screws.
2. Release clips.
3. Remove center mudguard.

Installation is in the reverse order of removal.

LICENSE LAMP FINISHER

PFP:84810

LICENSE LAMP FINISHER

Removal and Installation

EIS001K1

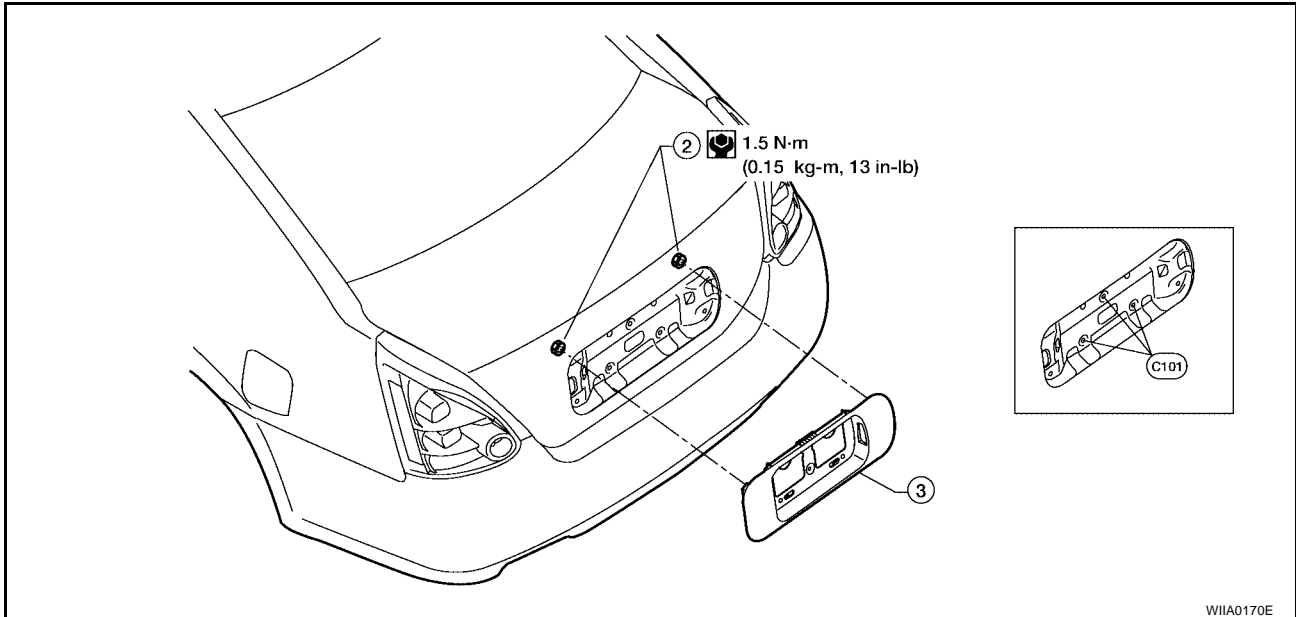

1. Remove trunk lid finisher. Refer to [EI-42, "TRUNK ROOM TRIM & TRUNK LID FINISHER"](#).
2. Remove nuts from license lamp finisher.
3. Remove license lamp finisher.

Installation is in the reverse order of removal.

REAR AIR SPOILER

PFK:K6030

REAR AIR SPOILER Removal and Installation

EIS001NE

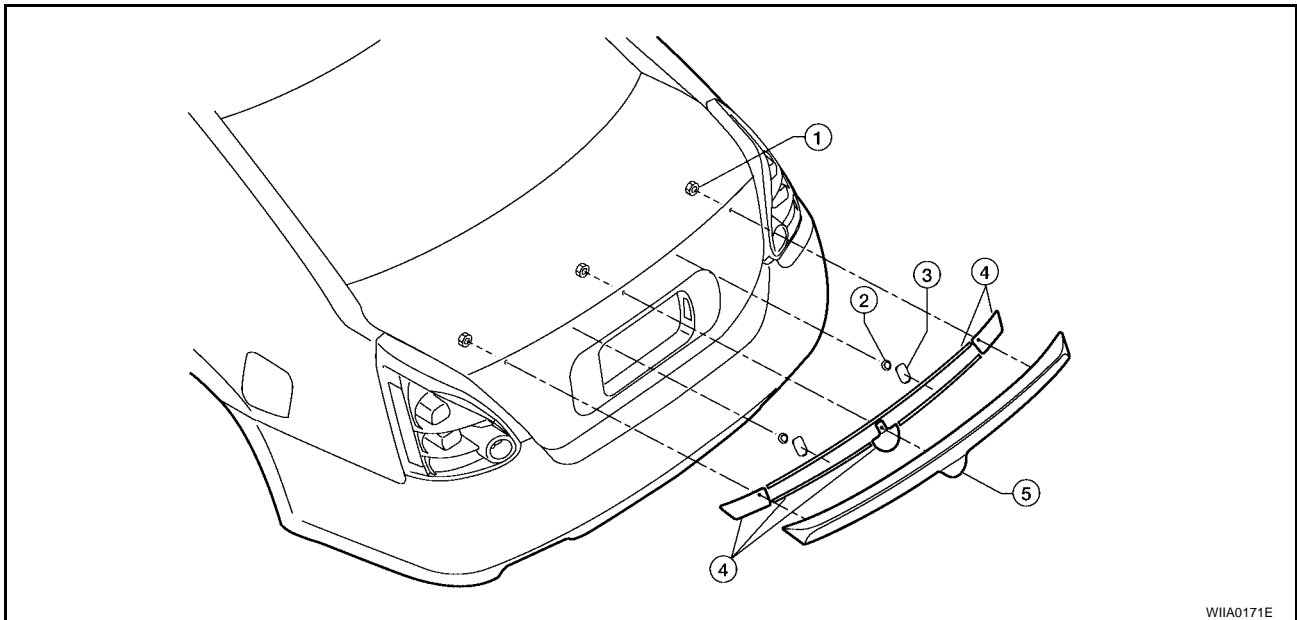

- | | | |
|----------------------|---------------------|-------------------|
| 1. Nuts | 2. Clips | 3. Clip retainers |
| 4. Double sided tape | 5. Rear air spoiler | |

1. Remove trunk lid finisher. Refer to [EI-42. "TRUNK ROOM TRIM & TRUNK LID FINISHER"](#).
2. Remove three nuts attaching spoiler to trunk lid.

CAUTION:

Use care not to damage paint on trunk and not to damage spoiler if it is to be replaced.

3. Using a trim stick, carefully remove spoiler by prying adhesive free.

NOTE:

Before installing spoiler, clean surface where spoiler will be mounted with isopropyl alcohol or equivalent to degrease the surface.

Installation is in the reverse order of removal.

- When installing, make sure that there are not any gaps or waves at the ends of the spoiler.

ROOF SIDE MOLDING

PFP:73854

ROOF SIDE MOLDING

Removal and Installation

EIS001KK

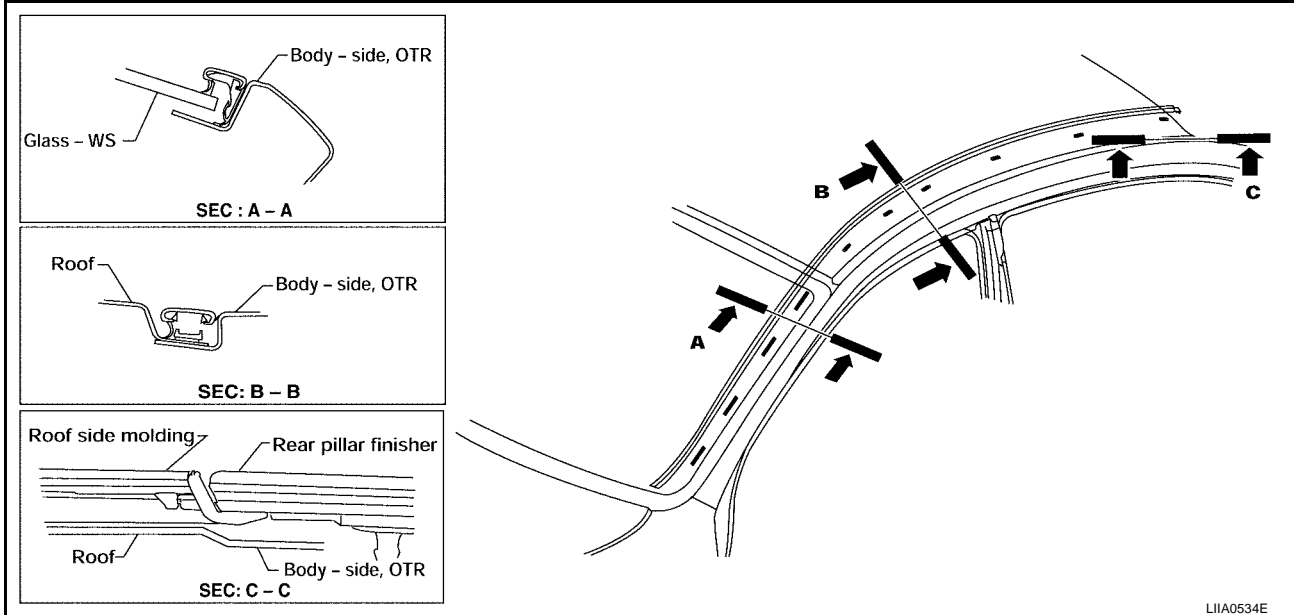

LIA0534E

1. Remove rear pillar finisher. Refer to [EI-27, "REAR PILLAR FINISHER"](#).
 2. Lift and twist roof side molding up from rear edge.
 3. Disconnect clips, and remove roof side molding.
- Installation is in the reverse order of removal.

REAR PILLAR FINISHER

REAR PILLAR FINISHER

PFP:76934

Removal and Installation

EIS001NF

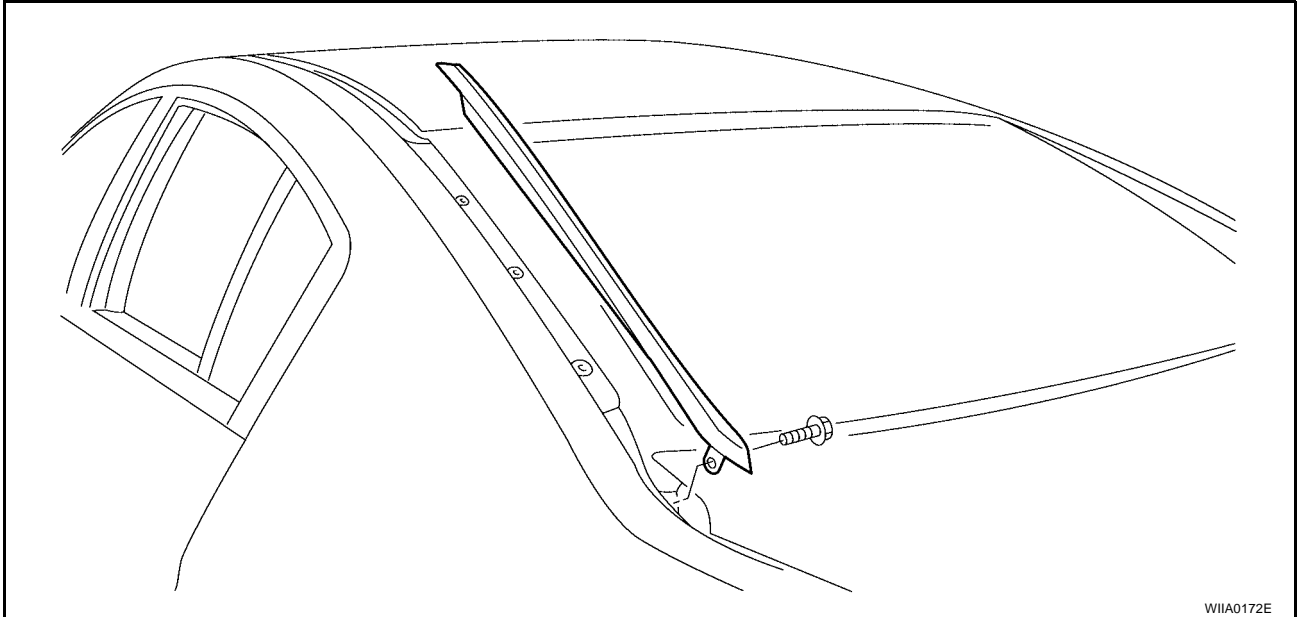

1. Remove screw in bottom corner of rear pillar finisher.
 2. Using a trim stick, release clips and remove finisher.
- Installation is in the reverse order of removal.

A
B
C
D
E
F
G
H

EI

J
K
L
M

DOOR OUTSIDE MOLDING

DOOR OUTSIDE MOLDING

PF8:82820

Removal and Installation

EIS001KL

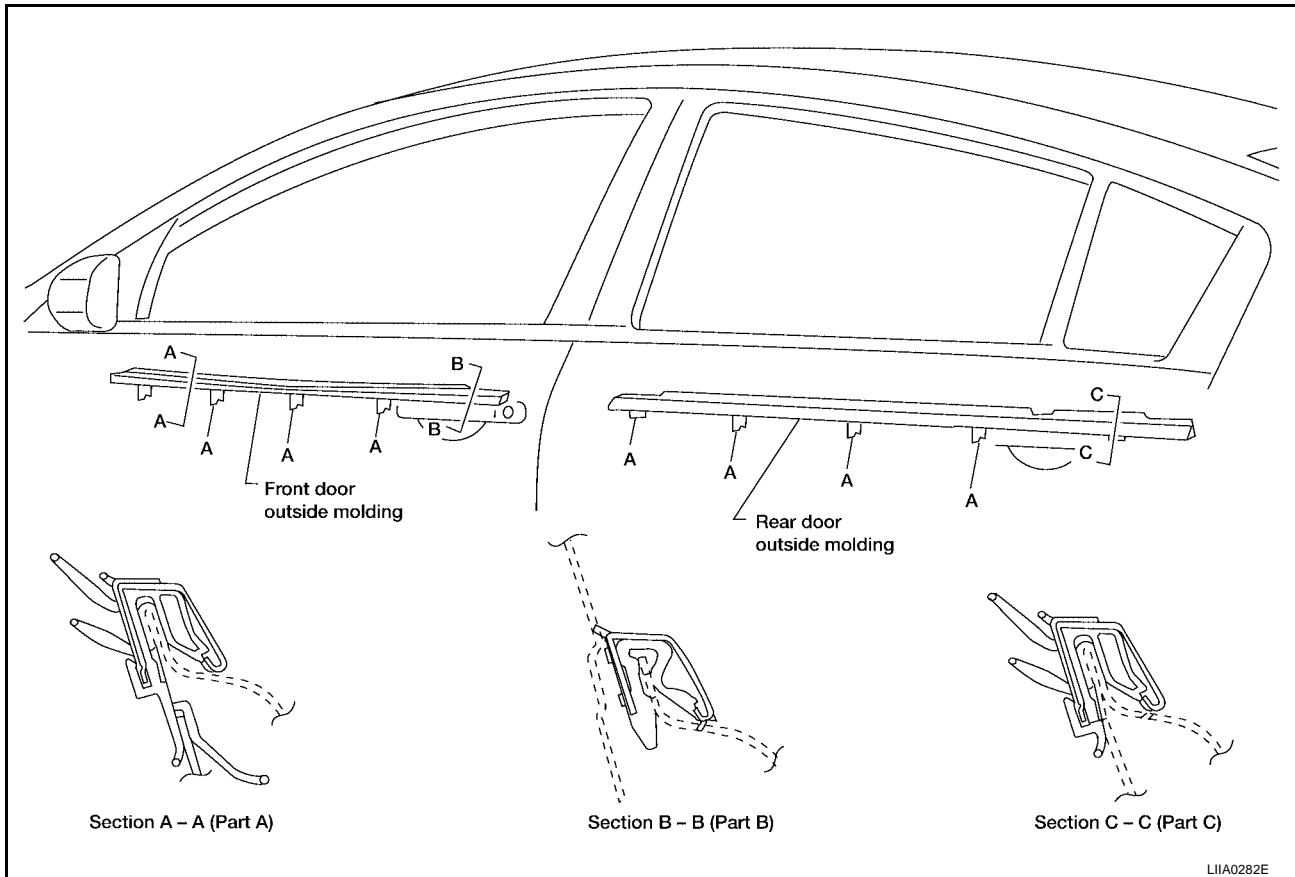

FRONT DOOR OUTSIDE MOLDING

Removal and Installation

1. Open windows fully.
 2. Lift and twist molding from rear side, disconnect clips from flange and remove molding.
- Installation is in the reverse order of removal.

REAR DOOR OUTSIDE MOLDING

Removal and Installation

1. Open windows fully.
 2. Lift and twist molding from rear side, and disconnect clips from flange and remove molding.
- Installation is in the reverse order of removal.

SIDE GUARD MOLDING

PFP:76840

SIDE GUARD MOLDING

Removal and Installation

EIS001KM

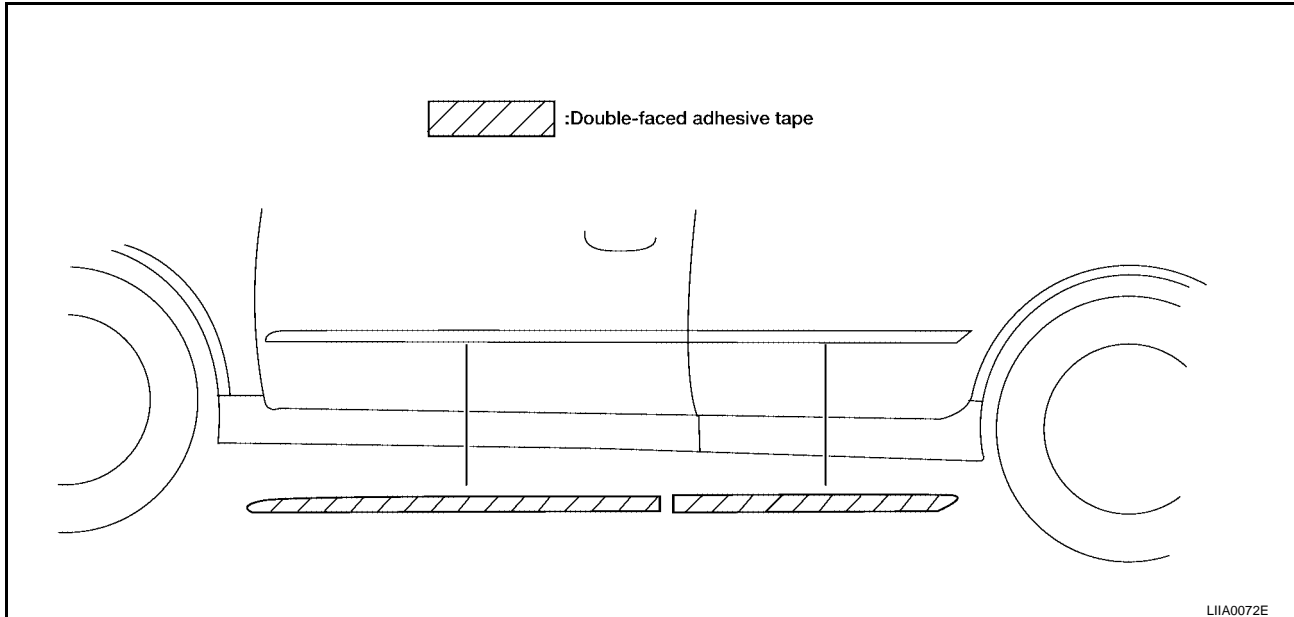

REMOVAL

CAUTION:

Never apply tack-paper adhesive remover to body panel surface finished with lacquer-based paints.

- Original side guard molding is affixed to body panel with double-faced adhesive tape.
1. Heat molding to between 30° and 40°C (86° to 104°F) with a heat gun.
 2. Raise end of molding and cut away tape to remove molding.
 3. Remove all traces of tape.

INSTALLATION

- On vehicles coated with Hard Clear Coat, use double-faced 3M adhesive tape Product No. 4210 or equivalent, after priming with 3M primer Product No. N200 or C-100 or equivalent.
 - The repair parts are also affixed with double-faced adhesive tape.
 - To re-use existing molding, clean all traces of double sided tape from the molding and apply new double-faced tape to the molding.
1. Clean the panel surface with isopropyl alcohol or equivalent to degrease the surface.
 2. Heat the panel and molding tape surface to 30° to 40°C (86° to 104°F).
 3. Remove the backing sheet from the tape surface.
 4. Press ends by hand and use a roller to apply 5 kg-f (11 lbs.-f) to press molding to door surface.

CAUTION:

To secure contact, do not wash vehicle for 24 hours after installation.

DOOR FINISHER

DOOR FINISHER

PF0:80900

Removal and Installation FRONT DOOR

EIS001KN

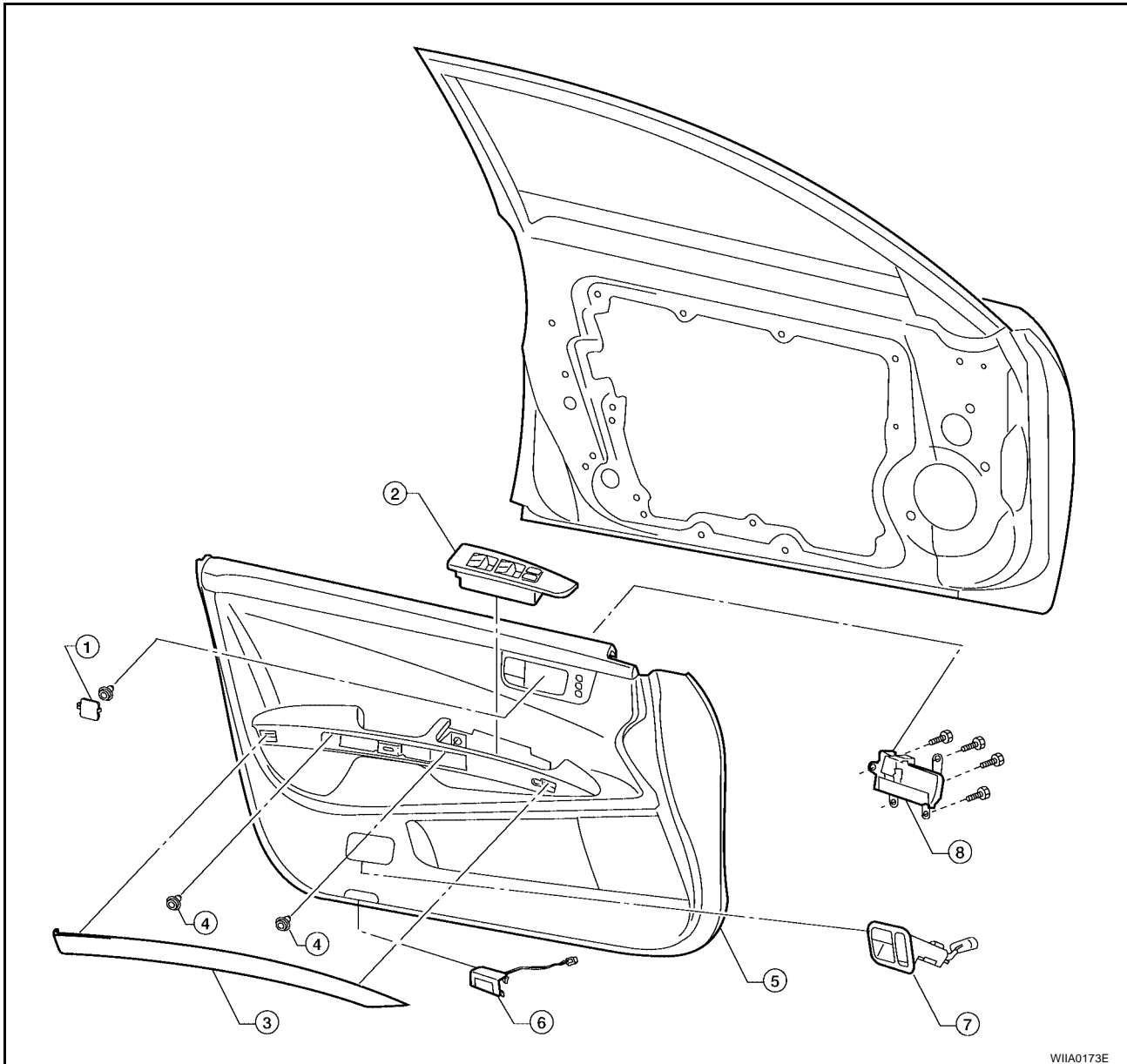

W11A0173E

1. Remove screw cover from handle escutcheon and remove screw.
2. Remove switch plate and disconnect harnesses.
3. Remove trim molding from armrest.
4. Remove screws attaching door finisher to inner door.
5. Remove door finisher.
6. Disconnect harness and remove step light.
7. Disconnect harness and remove trunk opener and fuel door opener switch assembly.
8. Disconnect lock cable and handle cable and remove handle assembly. Refer to [BL-68, "FRONT DOOR LOCK"](#) .

Installation is in the reverse order of removal.

DOOR FINISHER

REAR DOOR

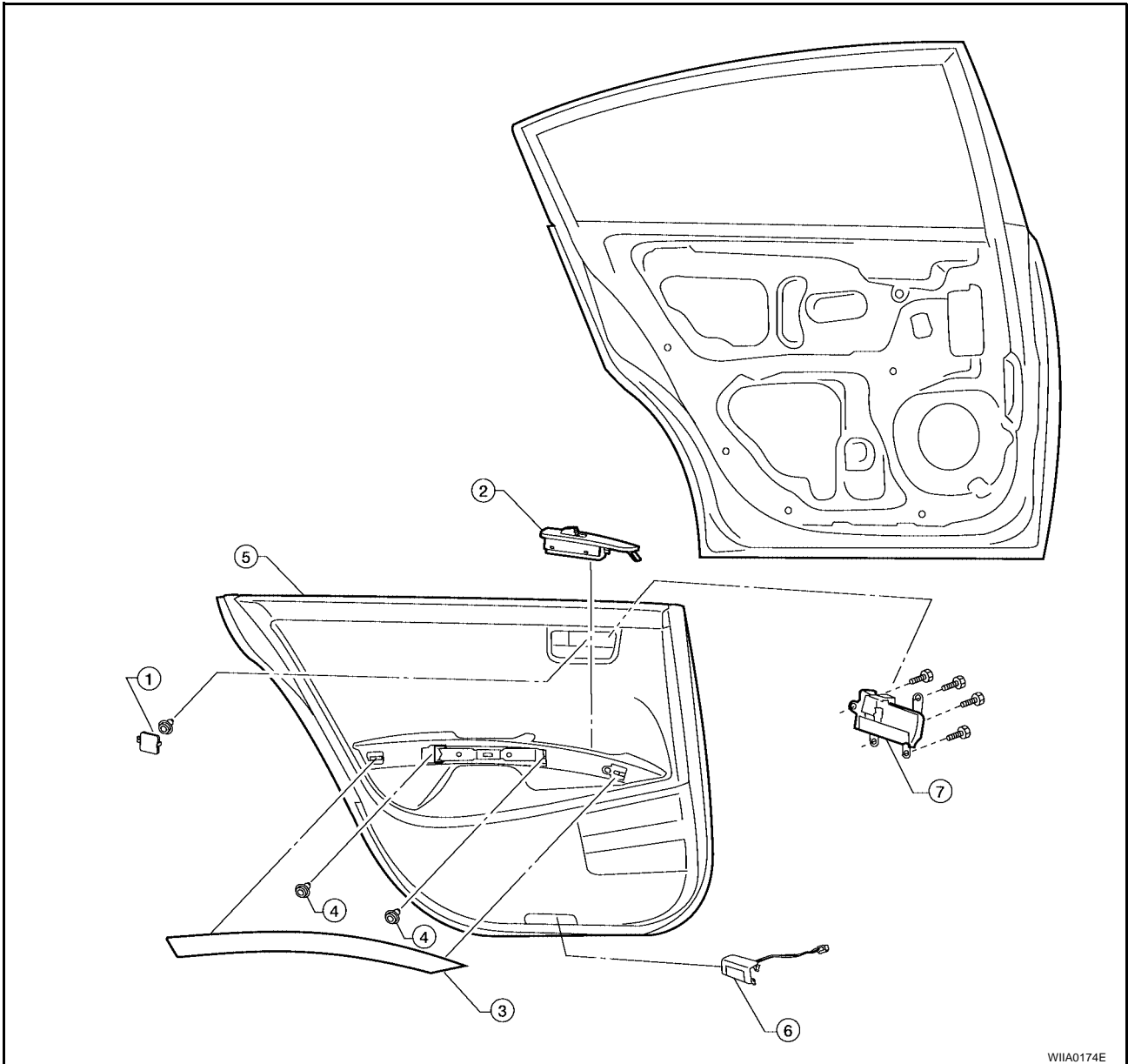

1. Remove screw cover from handle escutcheon and remove screw.
 2. Remove switch plate and disconnect harnesses.
 3. Remove trim molding from armrest.
 4. Remove 2 screws attaching door finisher to inner door.
 5. Remove door finisher.
 6. Disconnect harness from step light.
 7. Disconnect lock cable and handle cable.
- Installation is in the reverse order of removal.

BODY SIDE TRIM

BODY SIDE TRIM

PFP:76913

Removal and Installation

EIS001KO

CAUTION:

- Wrap the tip of flat-bladed screwdriver with a cloth when removing metal clips from garnishes.
- When removing or installing body side welts, do not allow butyl seal to come in contact with pillar garnish.

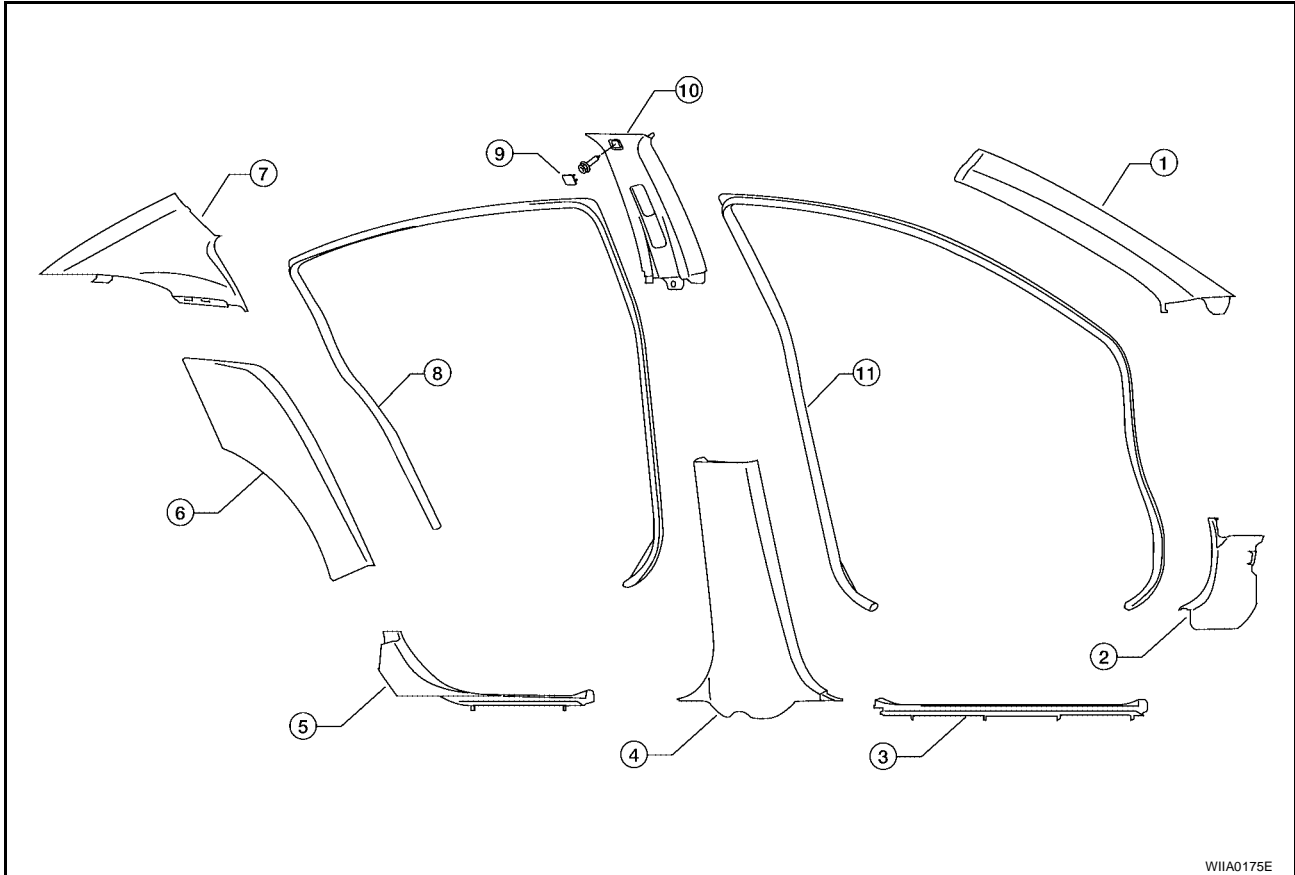

WIIA0175E

- | | | |
|---------------------------------|--------------------------|------------------------------------|
| 1. Front pillar garnish | 2. Dash side finisher | 3. Front kicking plate |
| 4. Center pillar lower garnish | 5. Rear kicking plate | 6. Rear pillar finisher |
| 7. Rear pillar garnish | 8. Rear body side welt | 9. Seat belt shoulder anchor cover |
| 10. Center pillar upper garnish | 11. Front body side welt | |

BODY SIDE TRIM

CENTER PILLAR LOWER GARNISH

Removal and Installation

1. Remove front and rear kicking plates.
2. Remove center pillar lower garnish.

Installation is in the reverse order of removal.

CENTER PILLAR UPPER GARNISH

Removal and Installation

1. Remove seat belt shoulder anchor. Refer to [SB-4, "Removal and Installation of Front Seat Belt"](#).
2. Remove front and rear kicking plate.
3. Remove center pillar lower garnish.
4. Remove bolt covers and bolts.
5. Remove center pillar upper garnish.

Installation is in the reverse order of removal.

REAR PILLAR FINISHER

Removal and Installation

1. Remove bolt cover and bolt.
2. Remove rear pillar finisher.

Installation is in the reverse order of removal.

DASH SIDE FINISHER

Removal and Installation

1. Remove front kicking plate.
2. Remove dash side finisher.

CAUTION:

Insert screw driver rolled with cloth between panel on vehicle and clips (as indicated with arrow), and disconnect clips.

Installation is in the reverse order of removal.

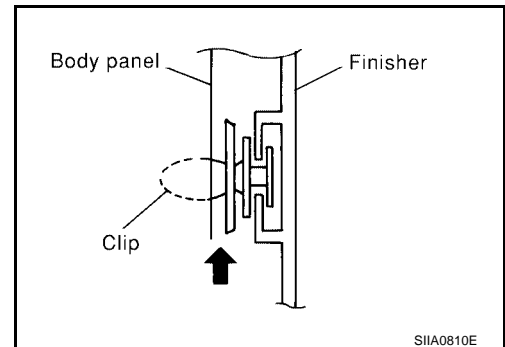

A

B

C

D

E

F

G

H

EI

J

K

L

M

REAR PARCEL SHELF FINISHER

REAR PARCEL SHELF FINISHER

PFP:79910

Removal and Installation

EIS001KP

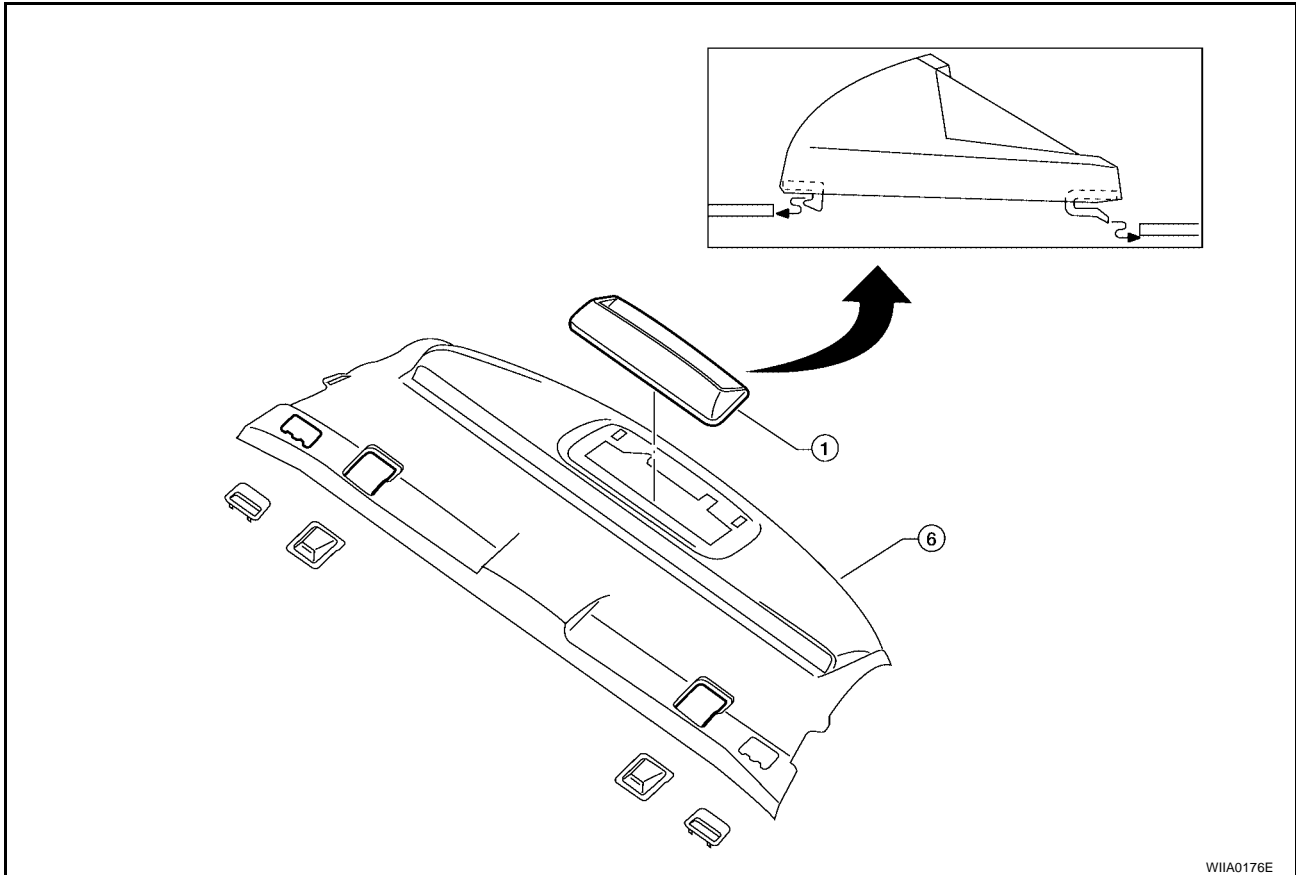

WIIA0176E

1. Remove rear seat. Refer to [SE-108, "REAR SEAT"](#) .
2. Remove rear seat belt anchor bolts. Refer to [SB-5, "Removal and Installation of Rear Seat Belt"](#) .
3. Remove rear pillar finisher. Refer to [EI-32, "BODY SIDE TRIM"](#) .
4. Remove high mounted stop lamp and disconnect connectors.

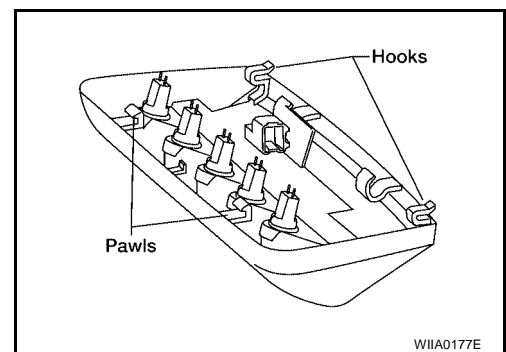

WIIA0177E

5. Remove halo trim.
 6. Remove rear parcel shelf trim.
- Installation is in the reverse order of removal.

SUNSHADE

SUNSHADE

PFP:97580

Component Parts and Harness Connector Location

EIS001NP

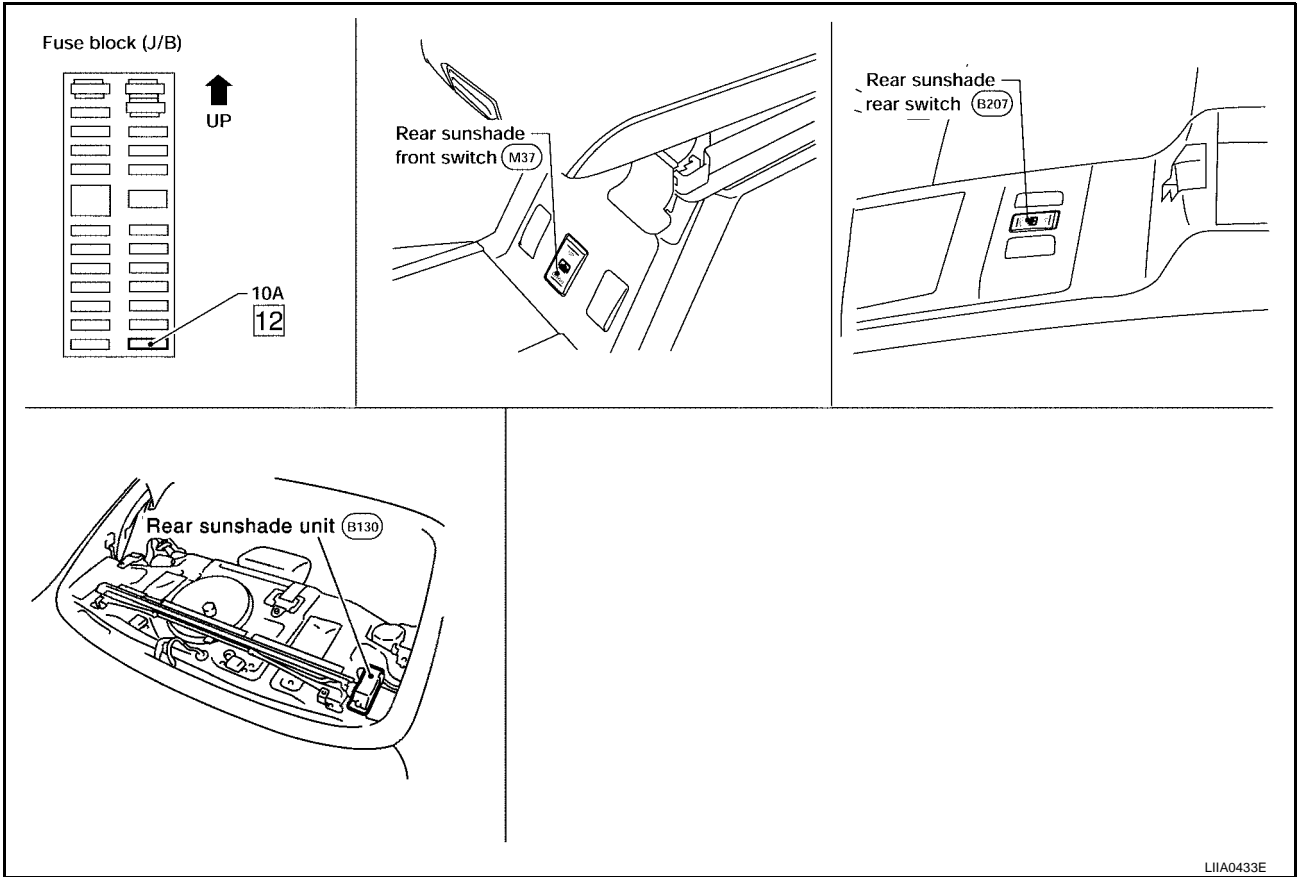

LIIA0433E

A
B
C
D
E
F
G
H
EI
J
K
L
M

EI

SUNSHADE

Wiring Diagram —SHADE—

EIS001N0

EI-SHADE-01

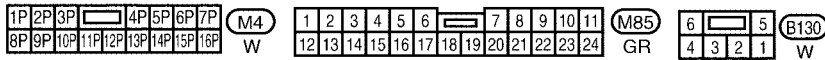
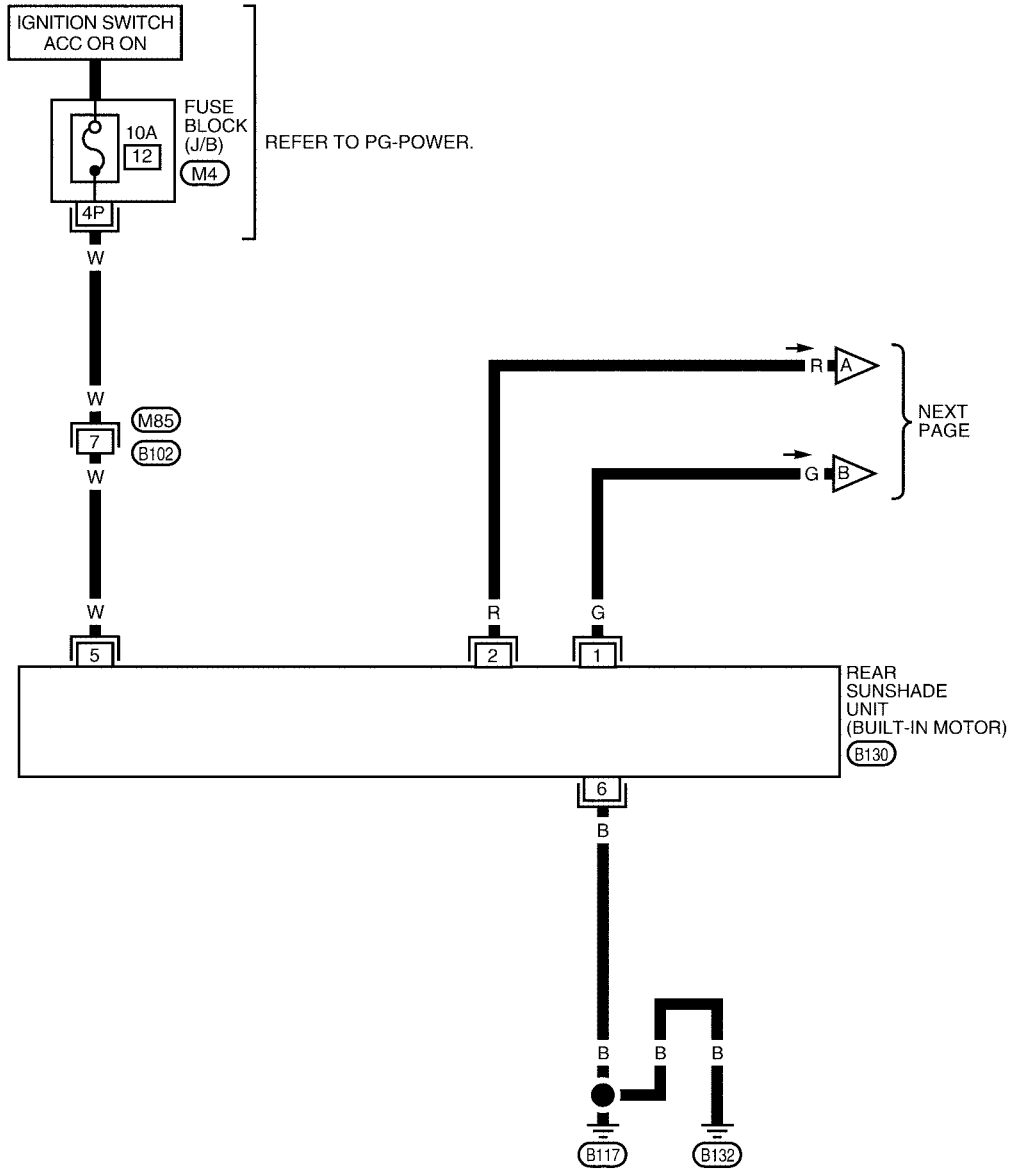

LIWA0072E

SUNSHADE

EI-SHADE-02

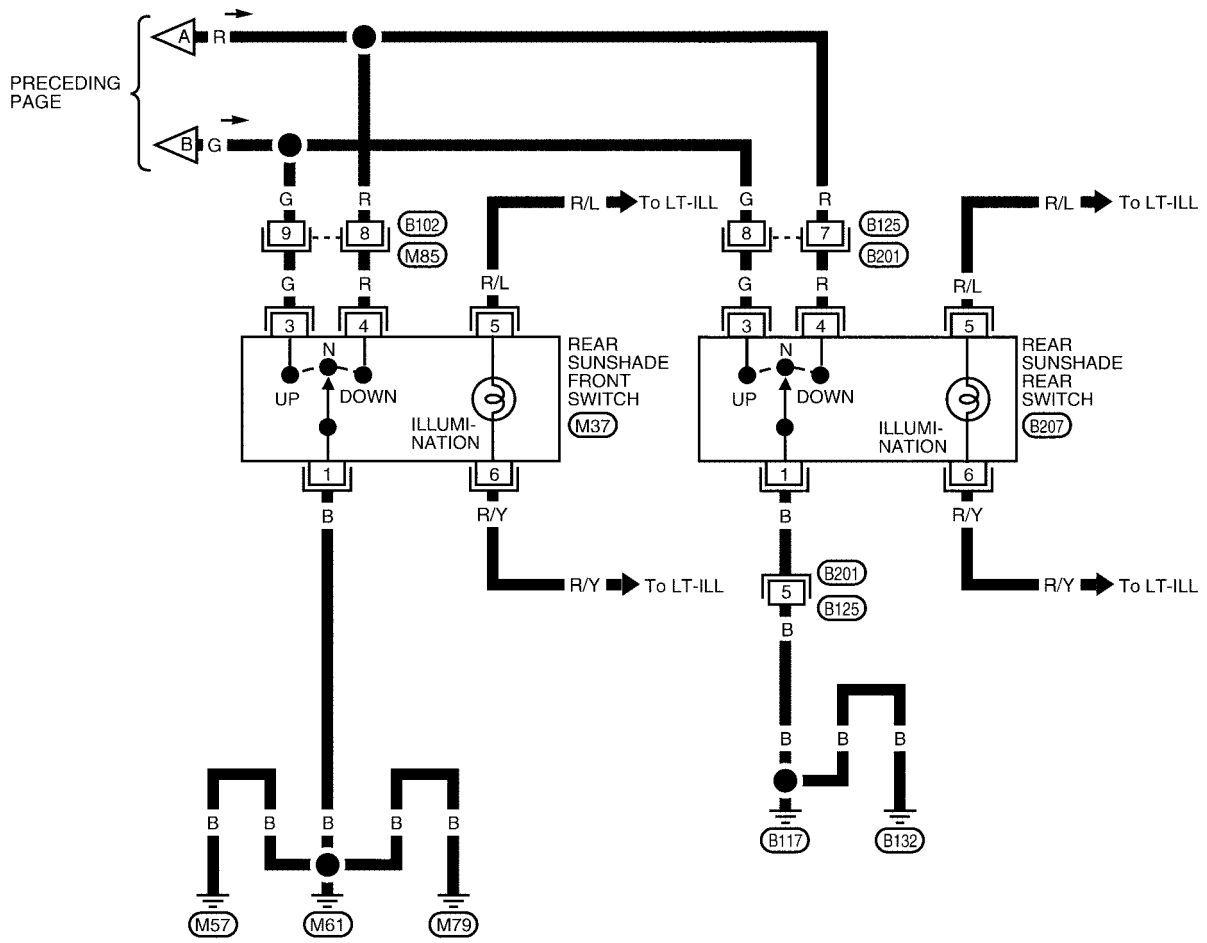

LIWA0073E

SUNSHADE

Removal and Installation

EIS001NH

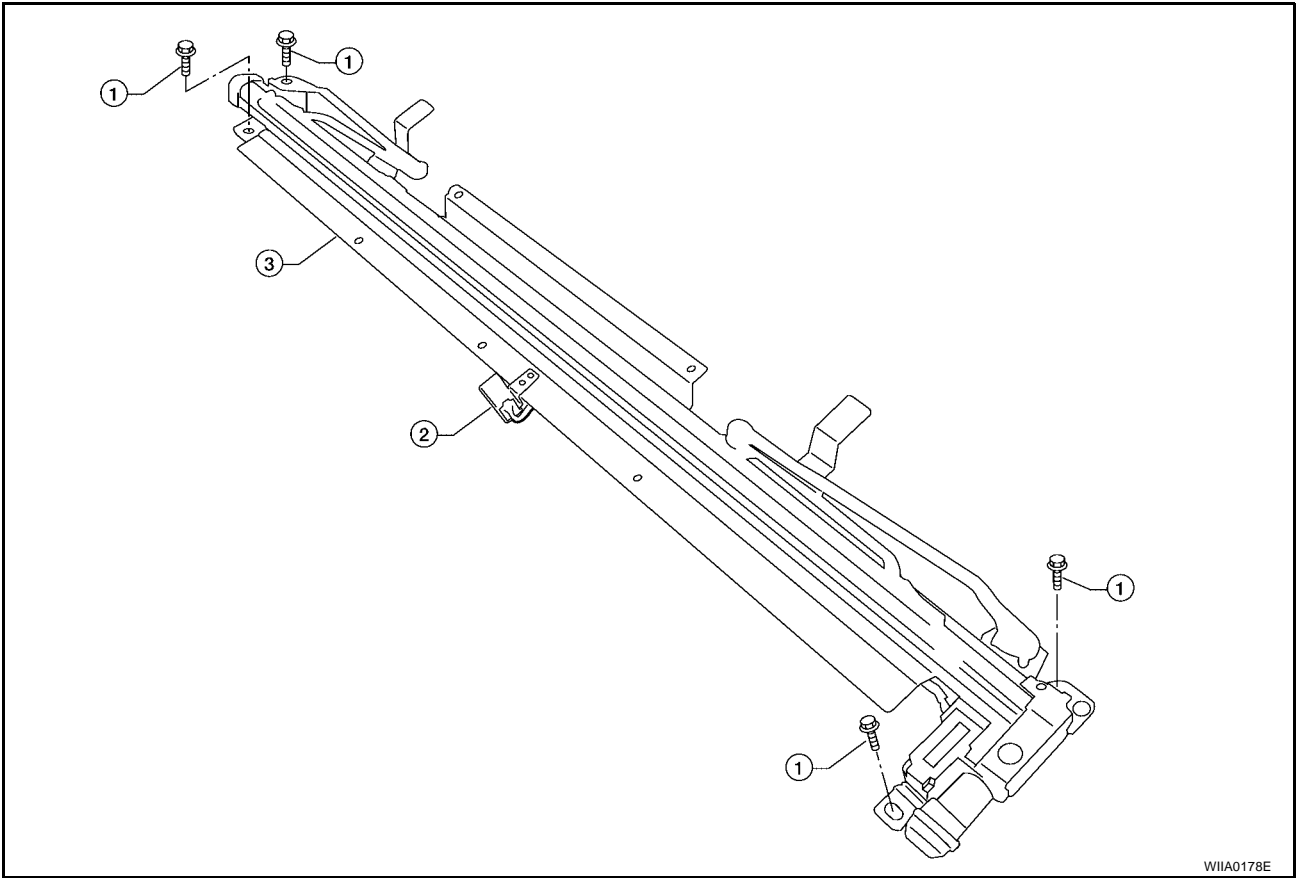

WIIA0178E

1. Remove rear parcel shelf finisher. Refer to [EI-34, "REAR PARCEL SHELF FINISHER"](#) .
2. Remove screws.
3. Disconnect wiring harness.
4. Remove rear sunshade.

Installation is in the reverse order of removal.

FLOOR TRIM

PF:74902

EIS001KQ

FLOOR TRIM

Removal and Installation

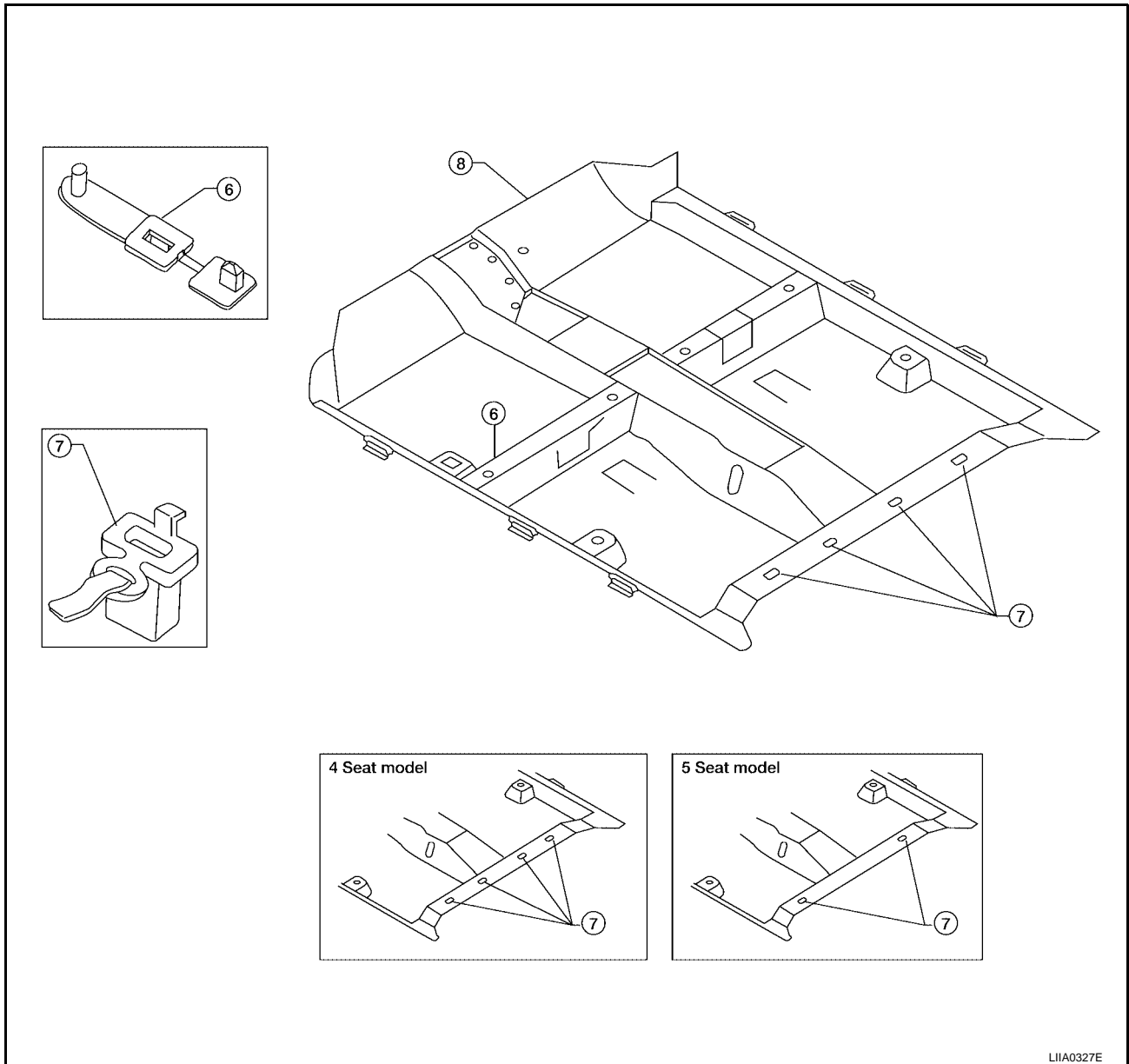

LIA0327E

1. Remove lower body side trim. Refer to [EI-32, "BODY SIDE TRIM"](#).
2. Remove front seats. Refer to [SE-103, "FRONT SEAT"](#).
3. Remove rear seat cushion. Refer to [SE-108, "REAR SEAT"](#).
 - On 4 seat model, remove seat backs.
4. Remove center console. Refer to [IP-10, "INSTRUMENT PANEL ASSEMBLY"](#).
5. Remove lower seat belt anchors. Refer to [SB-4, "SEAT BELTS"](#).
6. Remove service mat brackets.
7. Remove rear seat cushion hooks.
8. Remove carpet.

Installation is in the reverse order of removal.

HEADLINING

PFP:73910

EIS001KR

HEADLINING

Removal and Installation

Skyview Roof

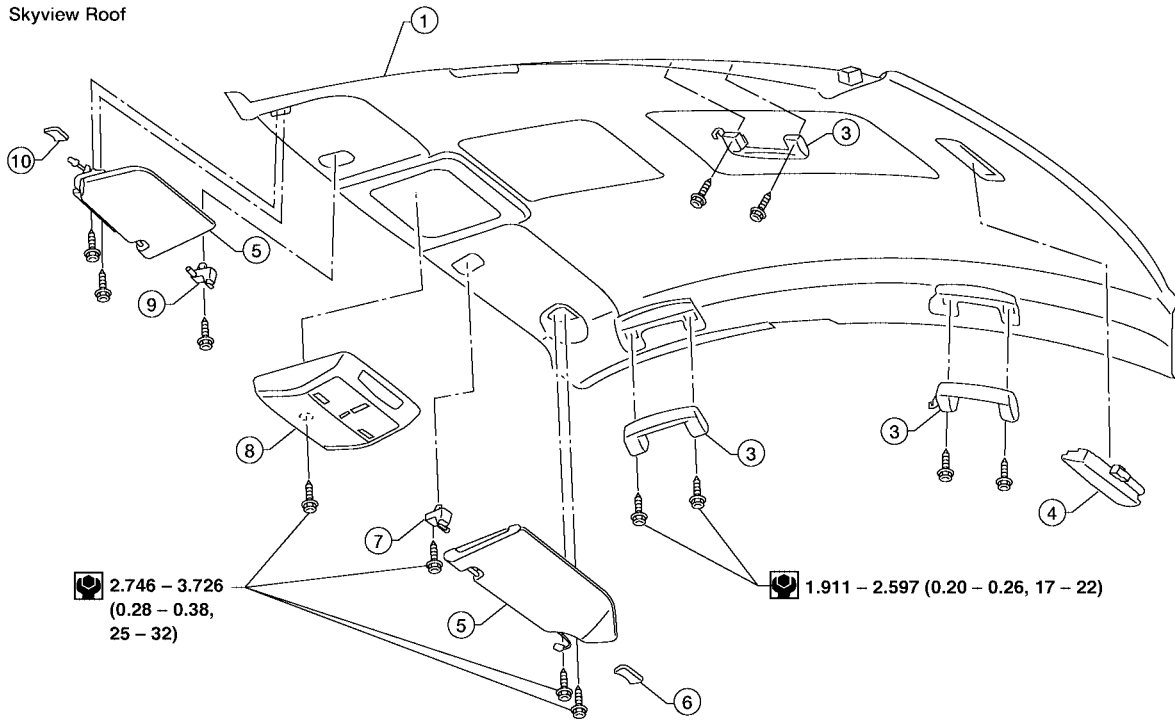

Sun Roof

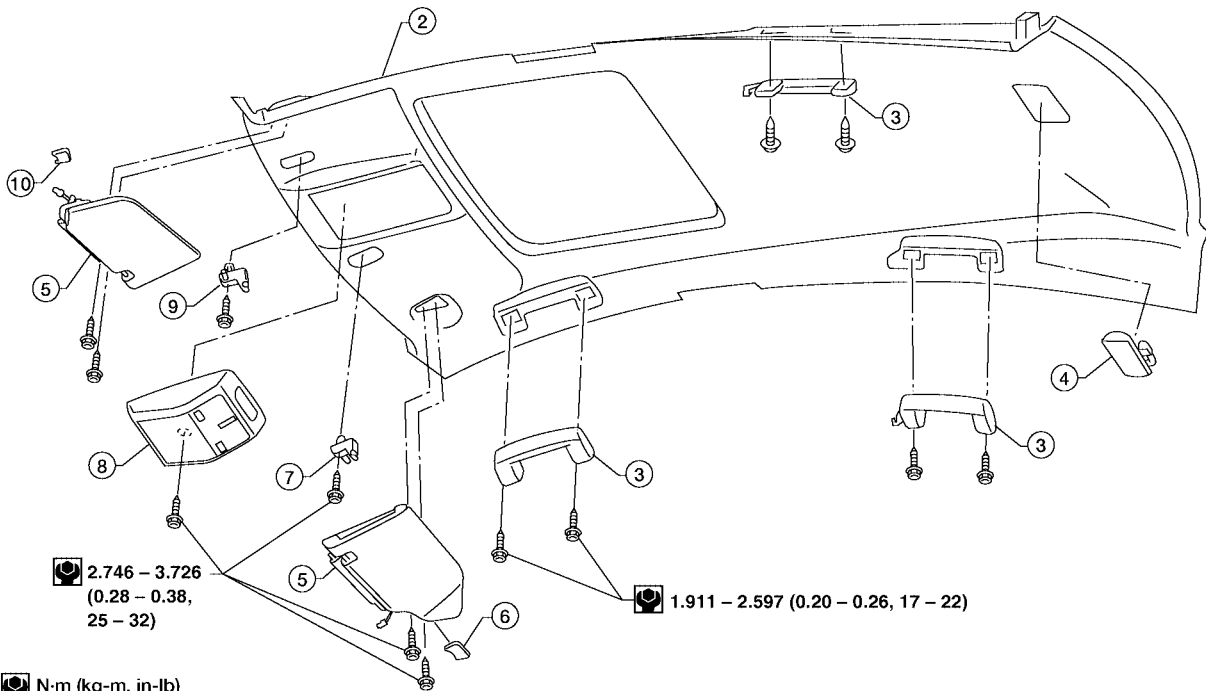

 N·m (kg·m, in·lb)

- | | | |
|----------------------------------|---------------------------|----------------------------------|
| 1. Headlining skyview roof | 2. Headlining sun roof | 3. Assist grips |
| 4. Interior lamp assembly | 5. Sunvisors | 6. Cap, RH |
| 7. Holder, sunvisor assembly, LH | 8. Console assembly, roof | 9. Holder, sunvisor assembly, LH |
| 10. Cap, LH | | |

WIIA0179E

HEADLINING

CAUTION:

Disconnect both terminals from battery in advance.

1. Remove front and rear door kicking plates. Refer to [EI-32, "BODY SIDE TRIM"](#) .
 2. Remove lower dash side trim. Refer to [EI-32, "BODY SIDE TRIM"](#) .
 3. Remove front pillar garnish, center pillar lower and upper garnish, and rear pillar garnish. Refer to [EI-32, "BODY SIDE TRIM"](#) .
 4. Remove front and rear door welts. Refer to [EI-32, "BODY SIDE TRIM"](#) .
 5. Remove assist grips.
 6. Remove interior lamp assembly.
 7. Remove roof console assembly.
 8. Remove RH and LH caps from sunvisor mounting brackets.
 9. Remove screws from each sunvisor mounting bracket and remove sunvisors.
 10. Remove sunvisor assembly holders.
 11. Remove windshield garnish molding. Refer to [EI-32, "BODY SIDE TRIM"](#) .
 12. Remove clips attaching headlining to roof.
 13. Take out headlining from the left rear door.
- Installation is in the reverse order of removal.

A

B

C

D

E

F

G

H

EI

J

K

L

M

TRUNK ROOM TRIM & TRUNK LID FINISHER

PFP:84920

TRUNK ROOM TRIM & TRUNK LID FINISHER

Removal and Installation

EIS001KS

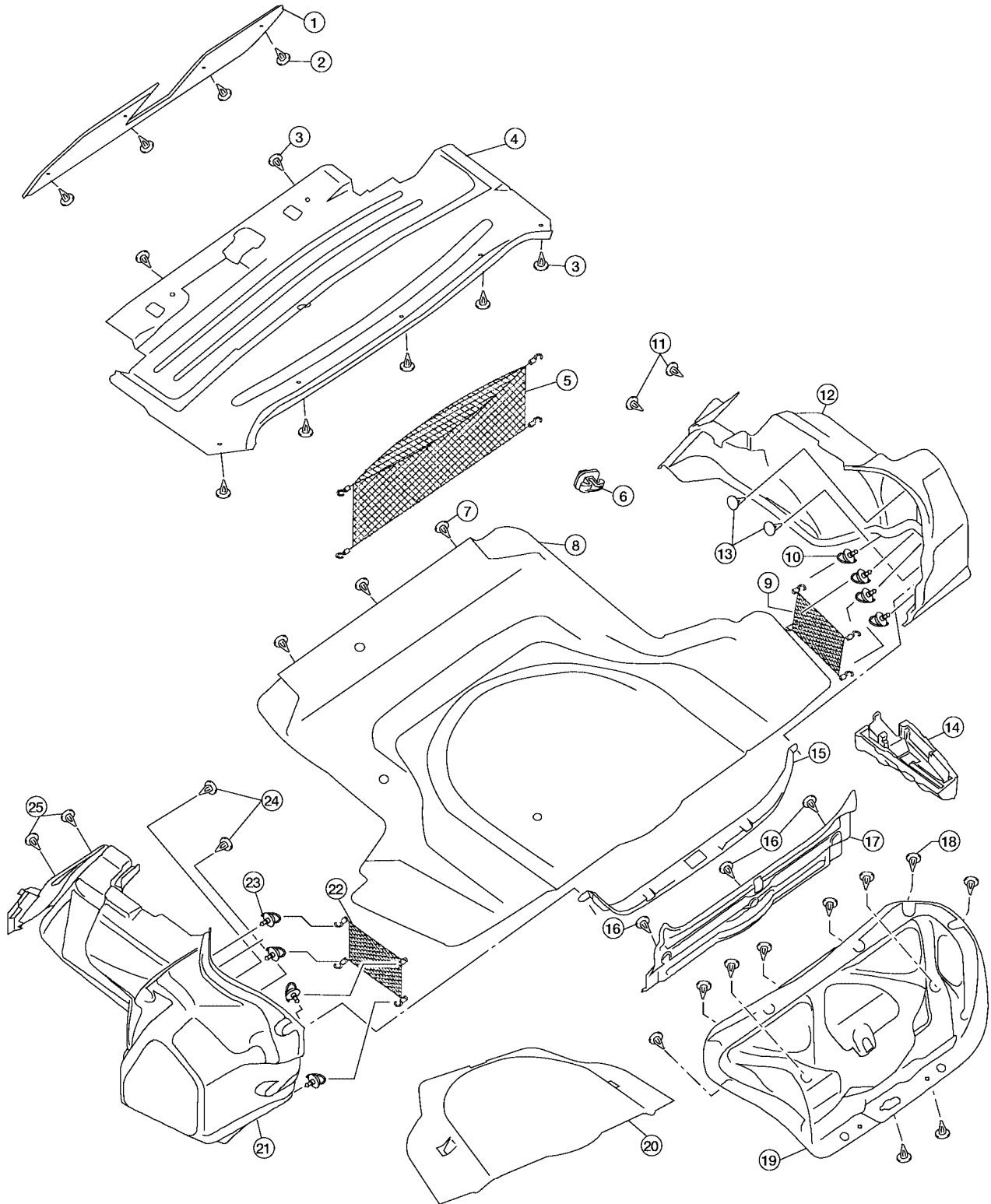

- 1. Trunk forward carpet
- 4. Upper trunk finisher
- 7. Trim clips
- 10. Trunk net hooks

- 2. Trim clips
- 5. Trunk net
- 8. Trunk floor carpet
- 11. Trim clips

- 3. Trim clips
- 6. Trunk room lamp
- 9. Trunk net, RH
- 12. Trunk side finisher, RH

WIIA0180E

TRUNK ROOM TRIM & TRUNK LID FINISHER

- | | | |
|------------------------|--------------------------|-----------------------------|
| 13. Trim clips | 14. Box assembly | 15. Rear trunk plate |
| 16. Trim clips | 17. Trunk finisher, rear | 18. Trim clips |
| 19. Trunk lid finisher | 20. Spare tire cover | 21. Trunk side finisher, LH |
| 22. Trunk net, LH | 23. Trunk net hooks | 24. Trim clips |
| 25. Trim clips | | |

A

B

C

D

E

F

G

H

EI

J

K

L

M

TRUNK ROOM TRIM & TRUNK LID FINISHER
