

SECTION **ATC**

AUTOMATIC AIR CONDITIONER

A
B
C
D
E
F
G
H
I
J
K
L
M
N
O
P

CONTENTS

<p>SERVICE INFORMATION 3</p> <p>PRECAUTIONS 3</p> <p style="padding-left: 20px;">Precaution for Supplemental Restraint System (SRS) "AIR BAG" and "SEAT BELT PRE-TENSIONER"3</p> <p style="padding-left: 20px;">Precaution for Working with HFC-134a (R-134a).....3</p> <p style="padding-left: 20px;">Contaminated Refrigerant3</p> <p style="padding-left: 20px;">General Refrigerant Precaution4</p> <p style="padding-left: 20px;">Precaution for Leak Detection Dye4</p> <p style="padding-left: 20px;">A/C Identification Label4</p> <p style="padding-left: 20px;">Precaution for Refrigerant Connection4</p> <p style="padding-left: 20px;">Precaution for Service of Compressor8</p> <p style="padding-left: 20px;">Precaution for Service Equipment8</p> <p>PREPARATION10</p> <p style="padding-left: 20px;">Special Service Tool 10</p> <p style="padding-left: 20px;">HFC-134a (R-134a) Service Tool and Equipment... 10</p> <p style="padding-left: 20px;">Commercial Service Tool 12</p> <p>REFRIGERATION SYSTEM14</p> <p style="padding-left: 20px;">Refrigerant Cycle 14</p> <p style="padding-left: 20px;">Refrigerant System Protection 14</p> <p style="padding-left: 20px;">Component Part Location 15</p> <p>OIL16</p> <p style="padding-left: 20px;">Maintenance of Oil Quantity in Compressor 16</p> <p>AIR CONDITIONER CONTROL18</p> <p style="padding-left: 20px;">Description of Air Conditioner LAN Control System 18</p> <p style="padding-left: 20px;">System Construction 18</p> <p style="padding-left: 20px;">Description of Control System 20</p> <p style="padding-left: 20px;">Control Operation 21</p> <p style="padding-left: 20px;">Fail-Safe Function 22</p> <p style="padding-left: 20px;">Discharge Air Flow 22</p> <p style="padding-left: 20px;">System Description 23</p> <p style="padding-left: 20px;">CAN Communication System Description 24</p> <p>TROUBLE DIAGNOSIS25</p> <p style="padding-left: 20px;">CONSULT-III Function (BCM) 25</p>	<p style="padding-left: 20px;">How to Perform Trouble Diagnosis for Quick and Accurate Repair25</p> <p style="padding-left: 20px;">Component Parts and Harness Connector Location26</p> <p style="padding-left: 20px;">Schematic29</p> <p style="padding-left: 20px;">Wiring Diagram - A/C,A -30</p> <p style="padding-left: 20px;">Unified Meter and A/C Amp. Terminal and Reference Value34</p> <p style="padding-left: 20px;">A/C System Self-Diagnosis Function34</p> <p style="padding-left: 20px;">Operational Check40</p> <p style="padding-left: 20px;">Power Supply and Ground Circuit for Front Air Control and Unified Meter and A/C Amp42</p> <p style="padding-left: 20px;">LAN System Circuit45</p> <p style="padding-left: 20px;">Mode Door Motor Circuit47</p> <p style="padding-left: 20px;">Air Mix Door Motor Circuit50</p> <p style="padding-left: 20px;">Air Mix Door Motor PBR Circuit53</p> <p style="padding-left: 20px;">Intake Door Motor Circuit53</p> <p style="padding-left: 20px;">Blower Motor Circuit55</p> <p style="padding-left: 20px;">Magnet Clutch Circuit61</p> <p style="padding-left: 20px;">Insufficient Cooling65</p> <p style="padding-left: 20px;">Insufficient Heating73</p> <p style="padding-left: 20px;">Noise74</p> <p style="padding-left: 20px;">Self-Diagnosis75</p> <p style="padding-left: 20px;">Memory Function77</p> <p style="padding-left: 20px;">Ambient Sensor Circuit77</p> <p style="padding-left: 20px;">In-vehicle Sensor Circuit80</p> <p style="padding-left: 20px;">Sunload Sensor Circuit82</p> <p style="padding-left: 20px;">Intake Sensor Circuit85</p> <p style="padding-left: 20px;">Multiplex Communication Circuit87</p> <p style="padding-left: 20px;">A/C Display (without NAVI)89</p> <p style="padding-left: 20px;">Front Air Control Self - Diagnosis90</p> <p>UNIFIED METER AND A/C AMP.92</p> <p style="padding-left: 20px;">Removal and Installation92</p> <p>AMBIENT SENSOR93</p> <p style="padding-left: 20px;">Removal and Installation93</p> <p>IN-VEHICLE SENSOR94</p> <p style="padding-left: 20px;">Removal and Installation94</p>
---	---

ATC

SUNLOAD SENSOR	95	Removal and Installation	105
Removal and Installation	95		
INTAKE SENSOR	96	DUCTS AND GRILLES	106
Removal and Installation	96	Removal and Installation	106
BLOWER UNIT	97	REFRIGERANT LINES	109
Removal and Installation	97	HFC-134a (R-134a) Service Procedure	109
BLOWER MOTOR	98	Component	111
Removal and Installation	98	Removal and Installation for Compressor	112
INTAKE DOOR MOTOR	99	Removal and Installation for Compressor Clutch	112
Removal and Installation	99	Removal and Installation for Low-Pressure Flexi- ble Hose	115
IN-CABIN MICROFILTER	100	Removal and Installation for High-pressure Flexi- ble Hose	115
Removal and Installation	100	Removal and Installation for High-pressure Pipe	116
HEATER & COOLING UNIT ASSEMBLY	101	Removal and Installation for Refrigerant Pressure Sensor	116
Removal and Installation	101	Removal and Installation for Condenser	116
HEATER CORE	102	Removal and Installation for Evaporator	117
Removal and Installation	102	Removal and Installation for Expansion Valve	118
MODE DOOR MOTOR	103	Checking of Refrigerant Leaks	119
Removal and Installation	103	Checking System for Leaks Using the Fluorescent Leak Detector	119
AIR MIX DOOR MOTOR	104	Dye Injection	120
Removal and Installation	104	Electronic Refrigerant Leak Detector	120
FAN CONTROL AMPLIFIER	105	SERVICE DATA AND SPECIFICATIONS (SDS)	123
		Service Data and Specification (SDS)	123

PRECAUTIONS

< SERVICE INFORMATION >

SERVICE INFORMATION

PRECAUTIONS

Precaution for Supplemental Restraint System (SRS) "AIR BAG" and "SEAT BELT PRE-TENSIONER"

INFOID:000000001721274

The Supplemental Restraint System such as "AIR BAG" and "SEAT BELT PRE-TENSIONER", used along with a front seat belt, helps to reduce the risk or severity of injury to the driver and front passenger for certain types of collision. This system includes seat belt switch inputs and dual stage front air bag modules. The SRS system uses the seat belt switches to determine the front air bag deployment, and may only deploy one front air bag, depending on the severity of a collision and whether the front occupants are belted or unbelted. Information necessary to service the system safely is included in the SRS and SB section of this Service Manual.

WARNING:

- To avoid rendering the SRS inoperative, which could increase the risk of personal injury or death in the event of a collision which would result in air bag inflation, all maintenance must be performed by an authorized NISSAN/INFINITI dealer.
- Improper maintenance, including incorrect removal and installation of the SRS, can lead to personal injury caused by unintentional activation of the system. For removal of Spiral Cable and Air Bag Module, see the SRS section.
- Do not use electrical test equipment on any circuit related to the SRS unless instructed to in this Service Manual. SRS wiring harnesses can be identified by yellow and/or orange harnesses or harness connectors.

Precaution for Working with HFC-134a (R-134a)

INFOID:000000001721275

WARNING:

- CFC-12 (R-12) refrigerant and HFC-134a (R-134a) refrigerant are not compatible. If the refrigerants are mixed compressor failure is likely to occur. Refer [ATC-3, "Contaminated Refrigerant"](#). To determine the purity of HFC-134a (R-134a) in the vehicle and recovery tank, use refrigerant recovery/recycling equipment and refrigerant identifier.
- Use only specified oil for the HFC-134a (R-134a) A/C system and HFC-134a (R-134a) components. If oil other than that specified is used, compressor failure is likely to occur.
- The specified HFC-134a (R-134a) oil rapidly absorbs moisture from the atmosphere. The following handling precautions must be observed:
 - When removing refrigerant components from a vehicle, immediately cap (seal) the component to minimize the entry of moisture from the atmosphere.
 - When installing refrigerant components to a vehicle, do not remove the caps (unseal) until just before connecting the components. Connect all refrigerant loop components as quickly as possible to minimize the entry of moisture into system.
 - Only use the specified oil from a sealed container. Immediately reseal containers of oil. Without proper sealing, oil will become moisture saturated and should not be used.
 - Avoid breathing A/C refrigerant and oil vapor or mist. Exposure may irritate eyes, nose and throat. Remove R-134a from the A/C system using certified service equipment meeting requirements of SAE J2210 (R-134a recycling equipment), or SAE J2209 (R-134a recovery equipment). If accidental system discharge occurs, ventilate work area before resuming service. Additional health and safety information may be obtained from refrigerant and oil manufacturers.
 - Do not allow refrigerant oil to come in contact with styrofoam parts. Damage may result.

Contaminated Refrigerant

INFOID:000000001721276

If a refrigerant other than pure R-134a is identified in a vehicle, your options are:

- Explain to the customer that environmental regulations prohibit the release of contaminated refrigerant into the atmosphere.
- Explain that recovery of the contaminated refrigerant could damage your service equipment and refrigerant supply.
- Suggest the customer return the vehicle to the location of previous service where the contamination may have occurred.
- If you choose to perform the repair, recover the refrigerant using only **dedicated equipment and containers. Do not recover contaminated refrigerant into your existing service equipment.** If your facility does

A
B
C
D
E
F
G
H
I
K
L
M
N
O
P

ATC

PRECAUTIONS

< SERVICE INFORMATION >

not have dedicated recovery equipment, you may contact a local refrigerant product retailer for available service. This refrigerant must be disposed of in accordance with all federal and local regulations. In addition, replacement of all refrigerant system components on the vehicle is recommended.

- If the vehicle is within the warranty period, the air conditioner warranty is void. Please contact NISSAN Customer Affairs for further assistance.

General Refrigerant Precaution

INFOID:000000001721277

WARNING:

- **Do not release refrigerant into the air. Use approved recovery/recycling equipment to capture the refrigerant every time an air conditioning system is discharged.**
- **Always wear eye and hand protection (goggles and gloves) when working with any refrigerant or air conditioning system.**
- **Do not store or heat refrigerant containers above 52°C (125°F).**
- **Do not heat a refrigerant container with an open flame; if container warming is required, place the bottom of the container in a warm pail of water.**
- **Do not intentionally drop, puncture, or incinerate refrigerant containers.**
- **Keep refrigerant away from open flames: poisonous gas will be produced if refrigerant burns.**
- **Refrigerant will displace oxygen, therefore be certain to work in well ventilated areas to prevent suffocation.**
- **Do not pressure test or leak test HFC-134a (R-134a) service equipment and/or vehicle air conditioning systems with compressed air during repair. Some mixtures of air and HFC-134a (R-134a) have been shown to be combustible at elevated pressures. These mixtures, if ignited, may cause injury or property damage. Additional health and safety information may be obtained from refrigerant manufacturers.**

Precaution for Leak Detection Dye

INFOID:000000001721278

- The A/C system contains a fluorescent leak detection dye used for locating refrigerant leaks. An ultraviolet (UV) lamp is required to illuminate the dye when inspecting for leaks.
- Always wear fluorescence enhancing UV safety glasses to protect your eyes and enhance the visibility of the fluorescent dye.
- The fluorescent dye leak detector is not a replacement for an electronic refrigerant leak detector. The fluorescent dye leak detector should be used in conjunction with an electronic refrigerant leak detector (J-41995).
- For your safety and the customer's satisfaction, read and follow all manufacturer's operating instructions and precautions prior to performing work.
- A compressor shaft seal should not be repaired because of dye seepage. The compressor shaft seal should only be repaired after confirming the leak with an electronic refrigerant leak detector (J-41995).
- Always remove any dye from the leak area after repairs are complete to avoid a misdiagnosis during a future service.
- Do not allow dye to come into contact with painted body panels or interior components. If dye is spilled, clean immediately with the approved dye cleaner. Fluorescent dye left on a surface for an extended period of time **cannot be removed**.
- Do not spray the fluorescent dye cleaning agent on hot surfaces (engine exhaust manifold, etc.).
- Do not use more than one bottle of refrigerant dye, 40 ml (1/4 ounce), per A/C system.
- Leak detection dyes for R-134a and R-12 A/C systems are different. Do not use R-134a leak detection dye in R-12 A/C systems or R-12 leak detection dye in R-134a A/C systems or A/C system damage may result.
- The fluorescent properties of the dye will remain for over three (3) years unless a compressor failure occurs.

A/C Identification Label

INFOID:000000001721279

Vehicles with factory installed fluorescent dye have this identification label on the underside of hood.

NOTE:

Vehicles with factory installed fluorescent dye have a green label.

Precaution for Refrigerant Connection

INFOID:000000001721280

A new type refrigerant connection has been introduced to all refrigerant lines except the following locations.

- Expansion valve to cooling unit
- Evaporator pipes to evaporator (inside cooling unit)
- Refrigerant pressure sensor

PRECAUTIONS

< SERVICE INFORMATION >

FEATURES OF NEW TYPE REFRIGERANT CONNECTION

- The O-ring has been relocated. It has also been provided with a groove for proper installation. This eliminates the chance of the O-ring being caught in, or damaged by, the mating part. The sealing direction of the O-ring is now set vertically in relation to the contacting surface of the mating part to improve sealing characteristics.
- The reaction force of the O-ring will not occur in the direction that causes the joint to pull out, thereby facilitating piping connections.

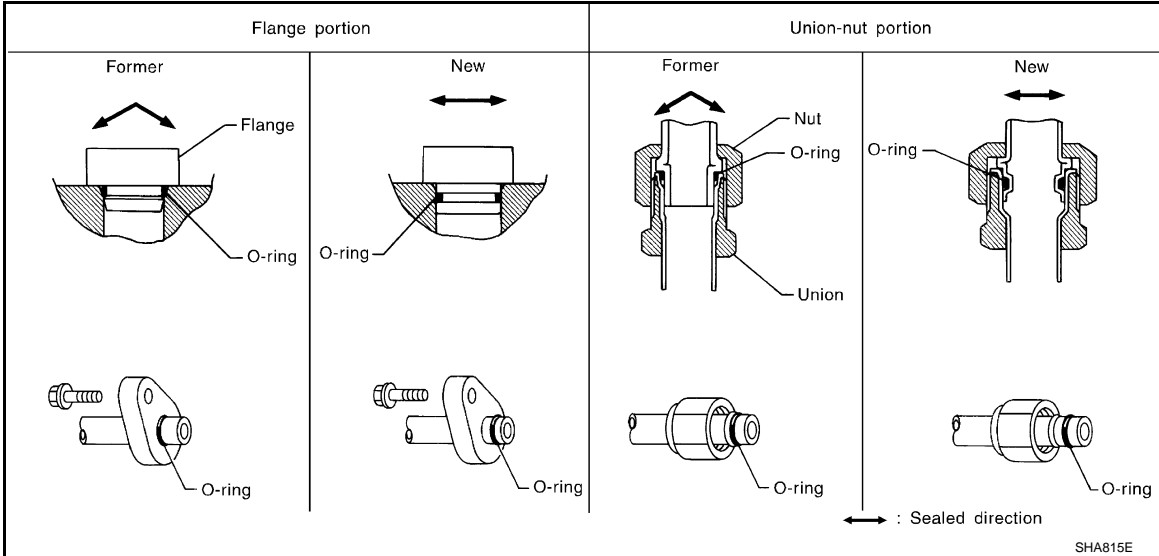

A
B
C
D
E
F
G
H
I

ATC

K
L
M
N
O
P

PRECAUTIONS

< SERVICE INFORMATION >

O-RING AND REFRIGERANT CONNECTION

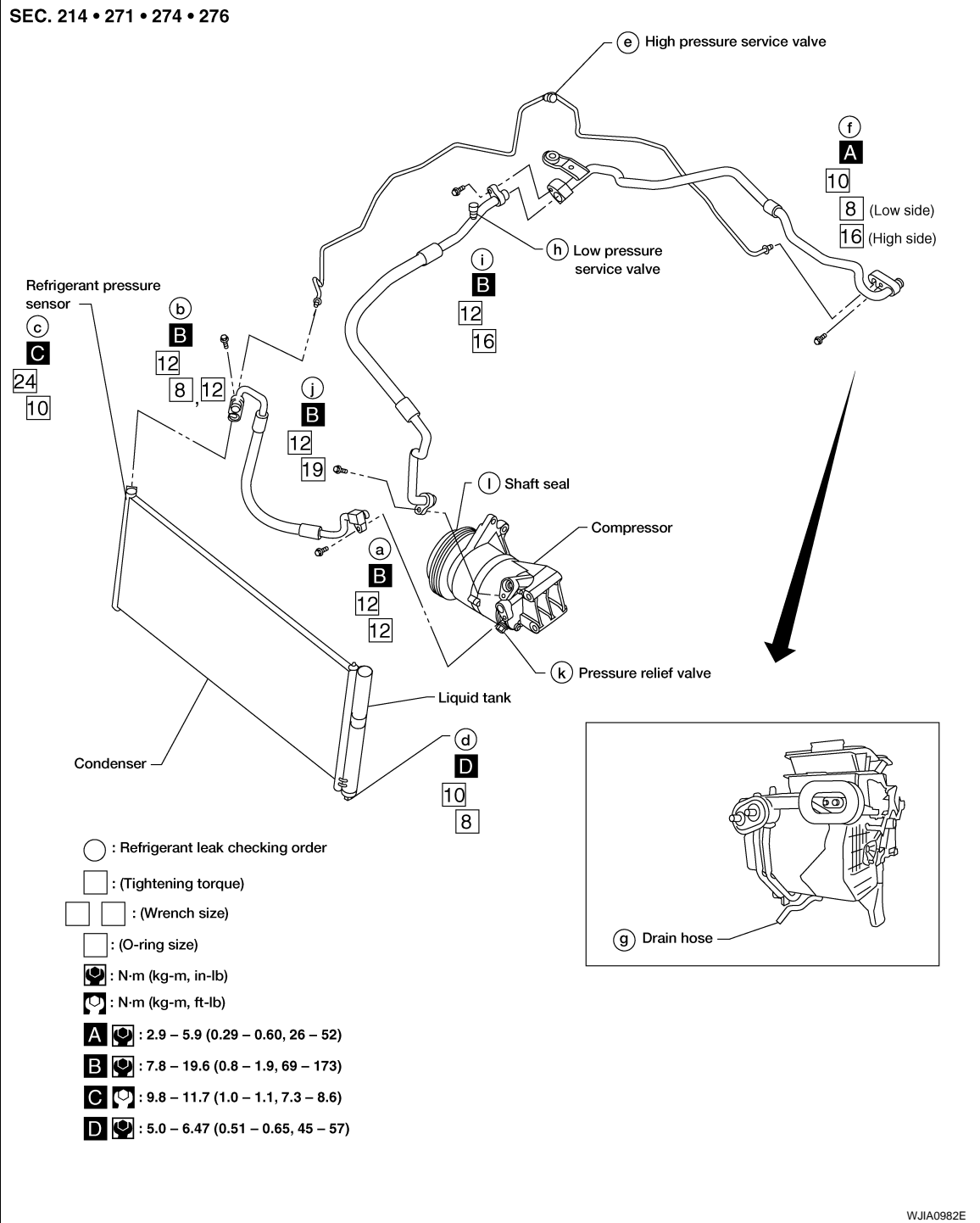

CAUTION:

The new and former refrigerant connections use different O-ring configurations. Do not confuse O-rings since they are not interchangeable. If a wrong O-ring is installed, refrigerant will leak at, or around, the connection.

O-Ring Part Numbers and Specifications

PRECAUTIONS

< SERVICE INFORMATION >

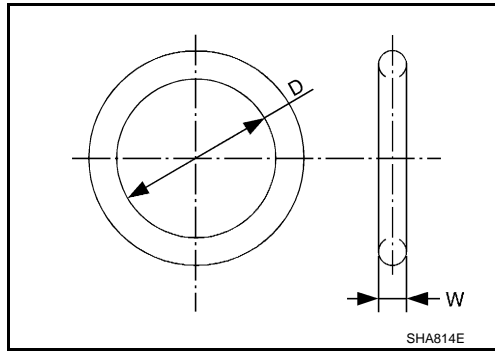

Connection type	O-ring size	Part number*	D mm (in)	W mm (in)
New	8	92471 N8210	6.8 (0.268)	1.85 (0.0728)
Former	10	J2476 89956	9.25 (0.3642)	1.78 (0.0701)
New	12	92472 N8210	10.9 (0.429)	2.43 (0.0957)
Former		92475 71L00	11.0 (0.433)	2.4 (0.094)
New	16	92473 N8210	13.6 (0.535)	2.43 (0.0957)
Former		92475 72L00	14.3 (0.563)	2.3 (0.091)
New	19	92474 N8210	16.5 (0.650)	2.43 (0.0957)
Former		92477 N8200	17.12 (0.6740)	1.78 (0.0701)
New	24	92195 AH300	21.8 (0.858)	2.4 (0.094)

*: Always check with the Parts Department for the latest parts information.

WARNING:

Make sure all refrigerant is discharged into the recycling equipment and the pressure in the system is less than atmospheric pressure. Then gradually loosen the discharge side hose fitting and remove it.

CAUTION:

When replacing or cleaning refrigerant cycle components, observe the following.

- When the compressor is removed, store it in the same position as it is when mounted on the car. Failure to do so will cause oil to enter the low pressure chamber.
 - When connecting tubes, always use a torque wrench and a back-up wrench.
 - After disconnecting tubes, immediately plug all openings to prevent entry of dirt and moisture.
 - When installing an air conditioner in the vehicle, connect the pipes as the final stage of the operation. Do not remove the seal caps of pipes and other components until just before required for connection.
 - Allow components stored in cool areas to warm to working area temperature before removing seal caps. This prevents condensation from forming inside A/C components.
 - Thoroughly remove moisture from the refrigeration system before charging the refrigerant.
 - Always replace used O-rings.
 - When connecting tube, apply oil to circle of the O-rings shown in illustration. Be careful not to apply oil to threaded portion.
- Oil name: NISSAN A/C System Oil Type S
- O-ring must be closely attached to dented portion of tube.
 - When replacing the O-ring, be careful not to damage O-ring and tube.
 - Connect tube until you hear it click, then tighten the nut or bolt by hand until snug. Make sure that the O-ring is installed to tube correctly.
 - After connecting line, conduct leak test and make sure that there is no leakage from connections. When the gas leaking point is found, disconnect that line and replace the O-ring. Then tighten connections of seal seat to the specified torque.

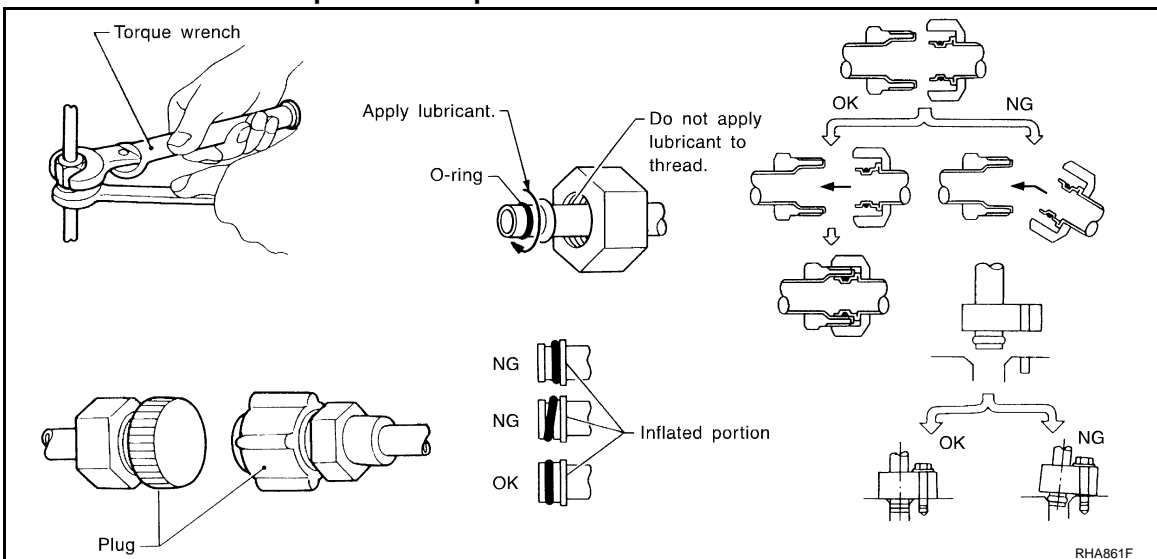

PRECAUTIONS

< SERVICE INFORMATION >

Precaution for Service of Compressor

INFOID:000000001721281

- Plug all openings to prevent moisture and foreign matter from entering.
- When the compressor is removed, store it in the same position as it is when mounted on the car.
- When replacing or repairing compressor, follow "Maintenance of Oil Quantity in Compressor" exactly. Refer to [ATC-16, "Maintenance of Oil Quantity in Compressor"](#).
- Keep friction surfaces between clutch and pulley clean. If the surface is contaminated, with oil, wipe it off by using a clean waste cloth moistened with thinner.
- After compressor service operation, turn the compressor shaft by hand more than 5 turns in both directions. This will equally distribute oil inside the compressor. After the compressor is installed, let the engine idle and operate the compressor for 1 hour.
- After replacing the compressor magnet clutch, apply voltage to the new one and check for normal operation. Refer to [ATC-61, "Magnet Clutch Circuit"](#).

Precaution for Service Equipment

INFOID:000000001721282

RECOVERY/RECYCLING EQUIPMENT

Follow the manufacturer's instructions for machine operation and machine maintenance. Never introduce any refrigerant other than that specified into the machine.

ELECTRONIC LEAK DETECTOR

Follow the manufacturer's instructions for tester operation and tester maintenance.

VACUUM PUMP

The oil contained inside the vacuum pump is not compatible with the specified oil for HFC-134a (R-134a) A/C systems. The vent side of the vacuum pump is exposed to atmospheric pressure so the vacuum pump oil may migrate out of the pump into the service hose. This is possible when the pump is switched off after evacuation (vacuuming) and hose is connected to it.

To prevent this migration, use a manual valve situated near the hose-to-pump connection, as follows.

- Usually vacuum pumps have a manual isolator valve as part of the pump. Close this valve to isolate the service hose from the pump.
- For pumps without an isolator, use a hose equipped with a manual shut-off valve near the pump end. Close the valve to isolate the hose from the pump.
- If the hose has an automatic shut off valve, disconnect the hose from the pump: as long as the hose is connected, the valve is open and lubricating oil may migrate.

Some one-way valves open when vacuum is applied and close under a no vacuum condition. Such valves may restrict the pump's ability to pull a deep vacuum and are not recommended.

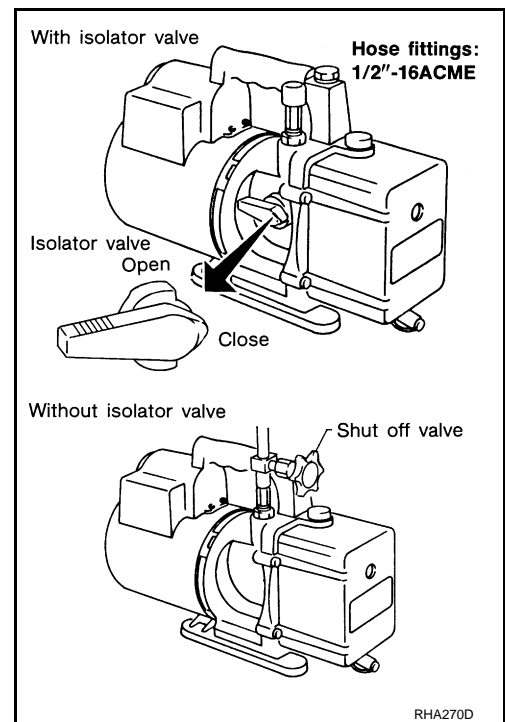

MANIFOLD GAUGE SET

Be certain that the gauge face indicates R-134a or 134a. Make sure the gauge set has 1/2''-16 ACME threaded connections for service hoses. Confirm the set has been used only with refrigerant HFC-134a (R-134a) along with specified oil.

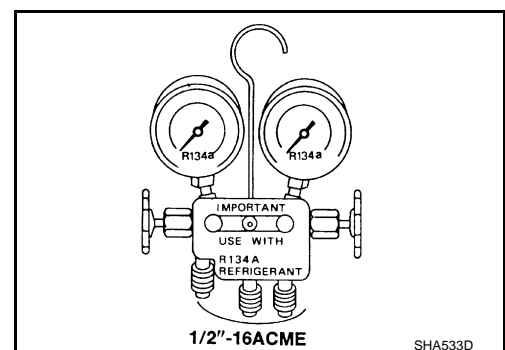

PRECAUTIONS

< SERVICE INFORMATION >

SERVICE HOSES

Be certain that the service hoses display the markings described (colored hose with black stripe). All hoses must include positive shut-off devices (either manual or automatic) near the end of the hoses opposite the manifold gauge.

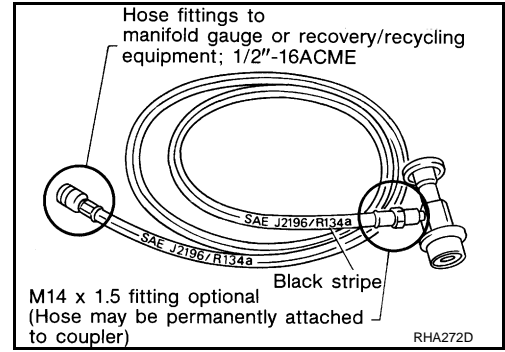

SERVICE COUPLERS

Never attempt to connect HFC-134a (R-134a) service couplers to a CFC-12 (R-12) A/C system. The HFC-134a (R-134a) couplers will not properly connect to the CFC-12 (R-12) system. However, if an improper connection is attempted, discharging and contamination may occur.

Shut-off valve rotation	A/C service valve
Clockwise	Open
Counterclockwise	Close

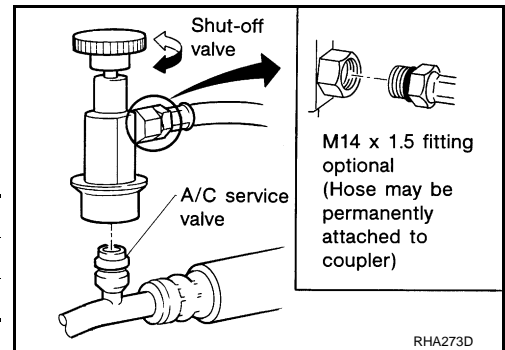

REFRIGERANT WEIGHT SCALE

Verify that no refrigerant other than HFC134a (R-134a) and specified oils have been used with the scale. If the scale controls refrigerant flow electronically, the hose fitting must be 1/2"-16 ACME.

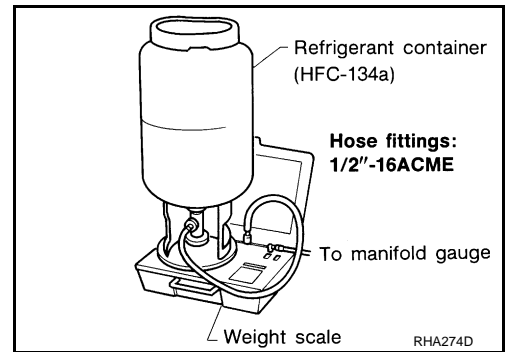

CHARGING CYLINDER

Using a charging cylinder is not recommended. Refrigerant may be vented into air from cylinder's top valve when filling the cylinder with refrigerant. Also, the accuracy of the cylinder is generally less than that of an electronic scale or of quality recycle/recharge equipment.

A
B
C
D
E
F
G
H
I
K
L
M
N
O
P

ATC

PREPARATION

< SERVICE INFORMATION >

PREPARATION

Special Service Tool

INFOID:000000001721283

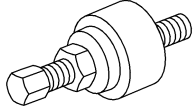
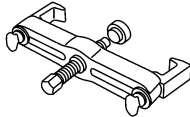

The actual shapes of Kent-Moore tools may differ from those of special service tools illustrated here.

Tool number (Kent-Moore No.) Tool name	Description
— (J-38873-A) Pulley installer <div style="text-align: center;">  <p>LHA171</p> </div>	Installing pulley
KV99233130 (J-29884) Pulley puller <div style="text-align: center;">  <p>LHA172</p> </div>	Removing pulley

HFC-134a (R-134a) Service Tool and Equipment

INFOID:000000001721284

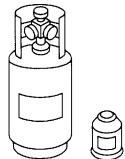
Never mix HFC-134a refrigerant and/or its specified oil with CFC-12 (R-12) refrigerant and/or its oil. Separate and non-interchangeable service equipment must be used for handling each type of refrigerant/oil. Refrigerant container fittings, service hose fittings and service equipment fittings (equipment which handles refrigerant and/or oil) are different between CFC-12 (R-12) and HFC-134a (R-134a). This is to avoid mixed use of the refrigerants/oil. Adapters that convert one size fitting to another must never be used refrigerant/oil contamination will occur and compressor failure will result.

Tool number (Kent-Moore No.) Tool name	Description
HFC-134a (R-134a) (—) Refrigerant <div style="text-align: center;">  <p>S-NT196</p> </div>	Container color: Light blue Container marking: HFC-134a (R-134a) Fitting size: Thread size • large container 1/2"-16 ACME
— (—) NISSAN A/C System Oil Type S <div style="text-align: center;">  <p>S-NT197</p> </div>	Type: Poly alkylene glycol oil (PAG), type S Application: HFC-134a (R-134a) vane rotary compressors (NISSAN only) Lubricity: 40 mℓ (1.4 US fl oz, 1.4 Imp fl oz)

PREPARATION

< SERVICE INFORMATION >

Tool number (Kent-Moore No.) Tool name	Description	
KV991J0130 (ACR2005-NI) ACR5 A/C Service Center	Refrigerant recovery, recycling and re-charging	A B C
— (J-41995) Electronic refrigerant leak detector	Checking for refrigerant leaks Power supply: DC 12V (battery terminal)	D E F G
— (J-43926) Refrigerant dye leak detection kit Kit includes: (J-42220) UV lamp and UV safety goggles (J-41459) Refrigerant dye injector (J-41447) Quantity 24, 1/4 ounce bottles of HFC-134a (R-134a) fluorescent leak detection dye (J-43872) Refrigerant dye cleaner	Leak detection dye Power supply: DC 12V (battery terminal)	H I ATC K
— (J-42220) Fluorescent dye leak detector	Checking for refrigerant leaks when fluorescent dye is installed in A/C system. Includes: UV lamp and UV safety goggles Power supply: DC 12V (battery terminal)	L M
— (J-41447) HFC-134a (R-134a) fluorescent leak detection dye (Box of 24, 1/4 ounce bottles)	Application: For HFC-134a (R-134a) PAG oil Container: 1/4 ounce (7.4cc) bottle (Includes self-adhesive dye identification labels for affixing to vehicle after charging system with dye.)	N O
— (J-41459) HFC-134a (R-134a) Dye injector Use with (J-41447) 1/4 ounce bottles	For injecting 1/4 ounce of fluorescent leak detection dye into A/C system.	P

PREPARATION

< SERVICE INFORMATION >

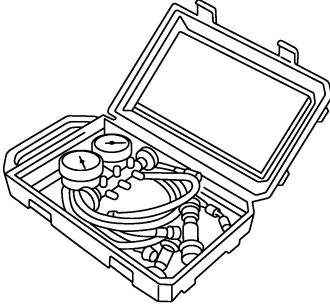
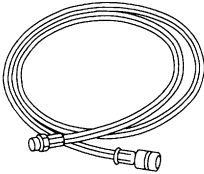
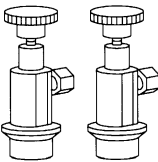
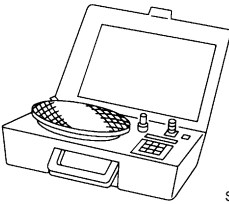
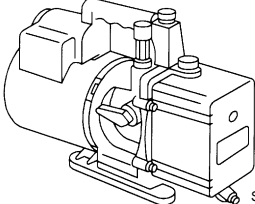
Tool number (Kent-Moore No.) Tool name	Description
<p>— (J-43872) Refrigerant dye cleaner</p>  <p style="text-align: right; margin-right: 50px;">SHA441F</p>	<p>For cleaning dye spills.</p>
<p>— (J-39183-C) Manifold gauge set (with hoses and couplers)</p>  <p style="text-align: right; margin-right: 50px;">RJIA0196E</p>	<p>Identification:</p> <ul style="list-style-type: none"> • The gauge face indicates R-134a. • Fitting size: Thread size • 1/2"-16 ACME
<p>Service hoses:</p> <ul style="list-style-type: none"> • (J-39500-72B) High side hose • (J-39500-72R) Low side hose • (J-39500-72Y) Utility hose  <p style="text-align: right; margin-right: 50px;">S-NT201</p>	<p>Hose colors:</p> <ul style="list-style-type: none"> • Low side hose: Blue with black stripe • High side hose: Red with black stripe • Utility hose: Yellow with black stripe or green with black stripe <p>Hose fitting to gauge:</p> <ul style="list-style-type: none"> • 1/2"-16 ACME
<p>Service couplers:</p> <ul style="list-style-type: none"> • (J-39500-20A) High side coupler • (J-39500-24A) Low side coupler  <p style="text-align: right; margin-right: 50px;">S-NT202</p>	<p>Hose fitting to service hose:</p> <ul style="list-style-type: none"> • M14 x 1.5 fitting is optional or permanently attached.
<p>— (J-39699) Refrigerant weight scale</p>  <p style="text-align: right; margin-right: 50px;">S-NT200</p>	<p>For measuring of refrigerant</p> <p>Fitting size - thread size:</p> <ul style="list-style-type: none"> • 1/2" - 16 ACME
<p>— (J-39649) Vacuum pump (Including the isolator valve)</p>  <p style="text-align: right; margin-right: 50px;">S-NT203</p>	<p>Capacity:</p> <ul style="list-style-type: none"> • Air displacement: 4 CFM • Micron rating: 20 microns • Oil capacity: 482 g (17 oz) <p>Fitting size: Thread size</p> <ul style="list-style-type: none"> • 1/2"-16 ACME

PREPARATION

< SERVICE INFORMATION >

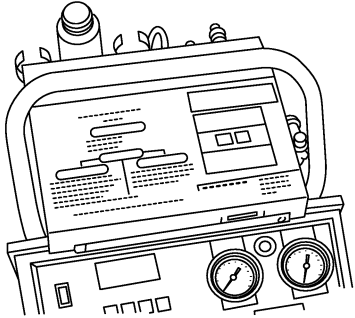
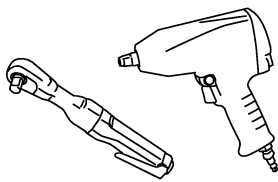
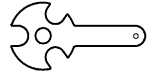
Tool name	Description	
<p>(J-41810-NI) Refrigerant identifier equipment (R-134a)</p>  <p style="text-align: right; font-size: small;">RJIA0197E</p>	<p>For checking refrigerant purity and system contamination</p>	<p>A</p> <p>B</p> <p>C</p> <p>D</p>
<p>Power tool</p>  <p style="text-align: right; font-size: small;">PBIC0190E</p>	<p>Loosening bolts and nuts</p>	<p>E</p> <p>F</p>
<p>(J-44614) Clutch disc holding tool</p>  <p style="text-align: right; font-size: small;">WHA230</p>	<p>Clutch disc holding tool</p>	<p>G</p> <p>H</p> <p>I</p>

ATC

K

L

M

N

O

P

REFRIGERATION SYSTEM

< SERVICE INFORMATION >

REFRIGERATION SYSTEM

Refrigerant Cycle

INFOID:000000001721286

Refrigerant flow

The refrigerant flows in the standard pattern, that is, through the compressor, the condenser with liquid tank, through the evaporator, and back to the compressor. The refrigerant evaporation through the evaporator coil is controlled by an externally equalized expansion valve, located inside the evaporator case.

Refrigerant System Protection

INFOID:000000001721287

Refrigerant pressure sensor

The refrigerant system is protected against excessively high or low pressures by the refrigerant pressure sensor, located on the condenser. If the system pressure rises above or falls below the specifications, the refrigerant pressure sensor detects the pressure inside the refrigerant line and sends the voltage signal to the ECM. ECM makes the A/C relay go OFF and stops the compressor when pressure on the high pressure side detected by refrigerant pressure sensor is over about 2,746 kPa (28 kg/cm², 398 psi), or below about 120 kPa (1.22 kg/cm², 17.4 psi).

Pressure Relief Valve

The refrigerant system is also protected by a pressure relief valve, located in the rear head of the compressor. When the pressure of refrigerant in the system increases to an abnormal level [more than 3,727 kPa (38 kg/cm², 540 psi)], the release port on the pressure relief valve automatically opens and releases refrigerant into the atmosphere.

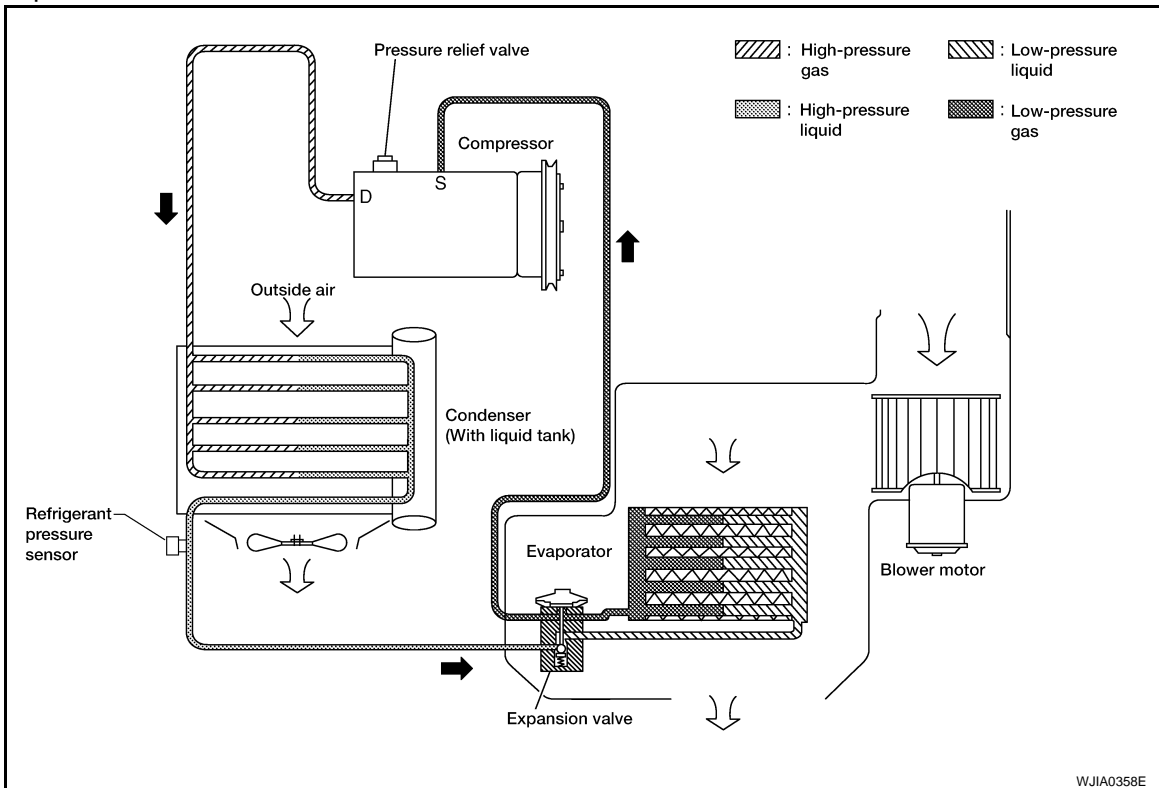

REFRIGERATION SYSTEM

< SERVICE INFORMATION >

Component Part Location

INFOID:000000001721288

SEC. 270 • 271 • 272 • 273

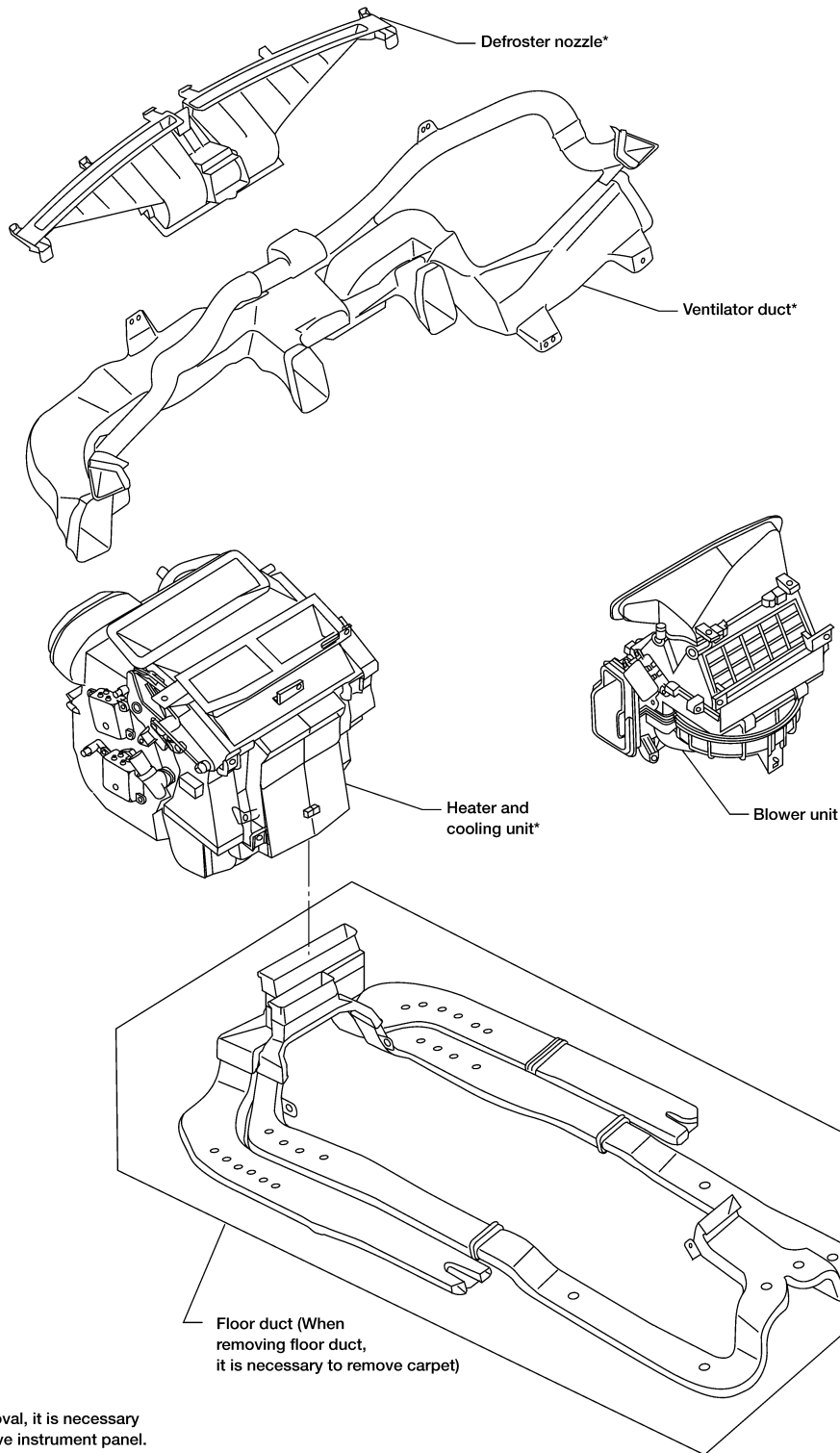

* For removal, it is necessary to remove instrument panel.

WJIA0294E

A
B
C
D
E
F
G
H
I
ATC
K
L
M
N
O
P

OIL

< SERVICE INFORMATION >

OIL

Maintenance of Oil Quantity in Compressor

INFOID:000000001721289

The oil in the compressor circulates through the system with the refrigerant. Add oil to compressor when replacing any component or after a large refrigerant leakage has occurred. It is important to maintain the specified amount.

If oil quantity is not maintained properly, the following malfunctions may result:

- Lack of oil, may lead to a seized compressor.
- Excessive oil, may cause inadequate cooling (thermal exchange interference).

OIL

Oil type: NISSAN A/C System Oil Type S

CHECKING AND ADJUSTING

CAUTION:

If excessive oil leakage is noted, do not perform the oil return operation.

Start the engine and set the following conditions:

Test Condition

- **Engine speed: Idling to 1,200 rpm**
- **A/C switch: On**
- **Blower fan speed: Max. position**
- **Temperature control: Optional [Set with intake air temperature at 25° to 30° C (77° to 86°F).]**
- **Intake position: Recirculation ()**
- **Perform oil return operation for about ten minutes**

Adjust the oil quantity according to the following table.

Oil Adjusting Procedure for Components Replacement Except Compressor

After replacing any of the following major components, add the correct amount of oil to the system.

Amount of Oil to be Added

Part replaced	Oil to be added to system	Remarks
	Amount of oil m ℓ (US fl oz, Imp fl oz)	
Evaporator	75 (2.5, 2.6)	—
Condenser	75 (2.5, 2.6)	—
Liquid tank	5 (0.2, 0.2)	Add if compressor is not replaced.
In case of refrigerant leak	30 (1.0, 1.1)	Large leak
	—	Small leak *1

*1: If refrigerant leak is small, no additional oil is needed.

Oil Adjustment Procedure for Compressor Replacement

OIL

< SERVICE INFORMATION >

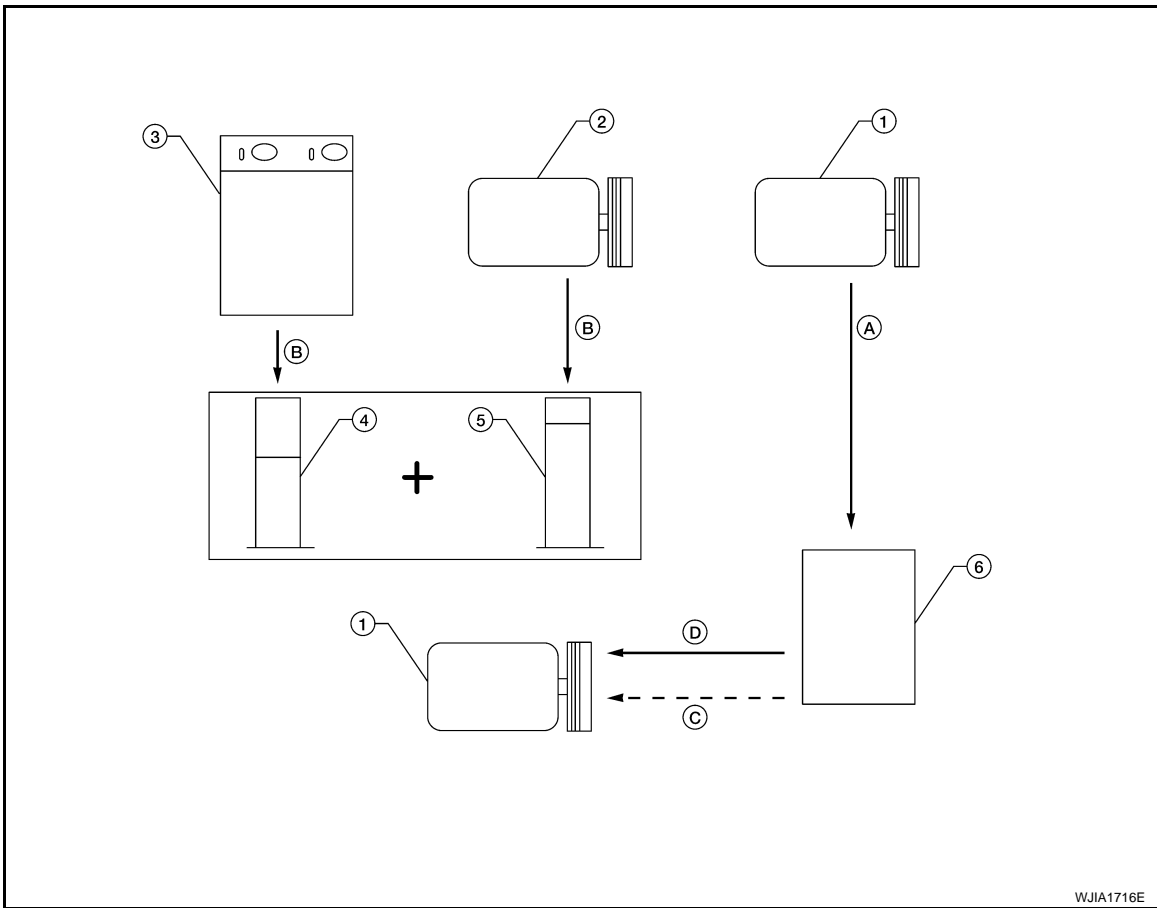

- | | | |
|---|-----------------------------------|--|
| 1. New compressor | 2. Old compressor | 3. Recovery/recycling equipment |
| 4. Measuring cup X | 5. Measuring cup Y | 6. New oil |
| A. Drain oil from the new compressor into clean container | B. Record amount of oil recovered | C. Add an additional 5 m ℓ (0.2 US fl oz, 0.2 Imp fl oz) of new oil when replacing liquid tank |
| D. Install new oil equal to recorded amounts in measuring cups X plus Y | | |

- Before connecting the recovery/recycling equipment to vehicle, check the recovery/recycling equipment gauges. No refrigerant pressure should be displayed. If NG, recover refrigerant from equipment lines.
- Connect the recovery/recycling equipment to vehicle. Confirm refrigerant purity in supply tank using the recovery/recycling equipment and refrigerant identifier. If NG, refer to [ATC-3, "Contaminated Refrigerant"](#).
- Confirm refrigerant purity in vehicle A/C system using the recovery/recycling equipment and refrigerant identifier. If NG, refer to [ATC-3, "Contaminated Refrigerant"](#).
- Discharge refrigerant into the refrigerant recovery/recycling equipment. Measure oil discharged into the recovery/recycling equipment.
- Drain the oil from the "old" (removed) compressor into a graduated container and recover the amount of oil drained.
- Drain the oil from the "new" compressor into a separate, clean container.
- Measure an amount of new oil installed equal to amount drained from "old" compressor. Add this oil to "new" compressor through the suction port opening.
- Measure an amount of new oil equal to the amount recovered during discharging. Add this oil to "new" compressor through the suction port opening.
- If the liquid tank also needs to be replaced, add an additional 5 m ℓ (0.2 US fl oz, 0.2 Imp fl oz) of oil at this time.

CAUTION:

Do not add this 5 m ℓ (0.2 US fl oz, 0.2 Imp fl oz) of oil if only replacing the compressor.

AIR CONDITIONER CONTROL

< SERVICE INFORMATION >

AIR CONDITIONER CONTROL

Description of Air Conditioner LAN Control System

INFOID:000000001721290

The LAN (Local Area Network) system consists of unified meter and A/C amp., mode door motor, air mix door motor and intake door motor.

A configuration of these components is shown in the figure below.

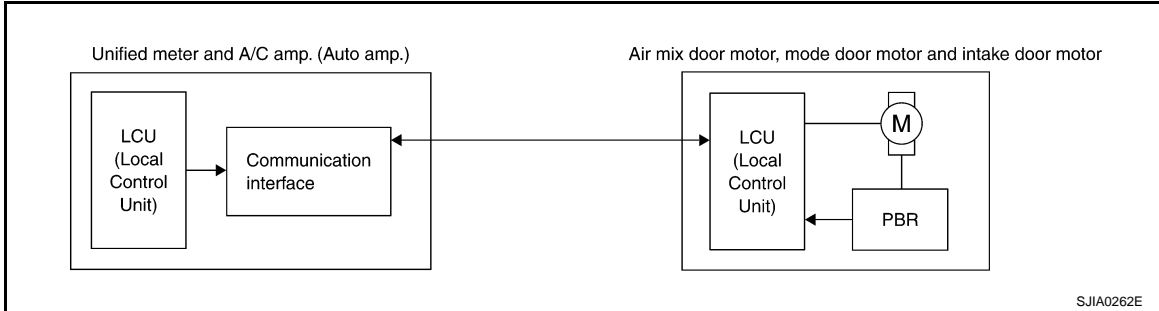

System Construction

INFOID:000000001721291

A small network is constructed between the unified meter and A/C amp., air mix door motor, mode door motor and intake door motor. The unified meter and A/C amp. and motors are connected by data transmission lines and motor power supply lines. The LAN communication is achieved using the dedicated communication line and ground line between each door motor and the unified meter and A/C amp.

The unified meter and A/C amp. identifies each motor type by its unique Address. Serial communication includes positioning and error checking information.

The following functions are contained in LCU's built into the air mix motor, mode door motor, and intake door motor.

- Address
- Motor opening angle signals
- Data transmission
- Motor stop and drive decision
- Opening angle sensor [Position balanced resistor (PBR) function]
- Comparison
- Decision (Unified meter and A/C amp. indicated value and motor opening angle comparison)

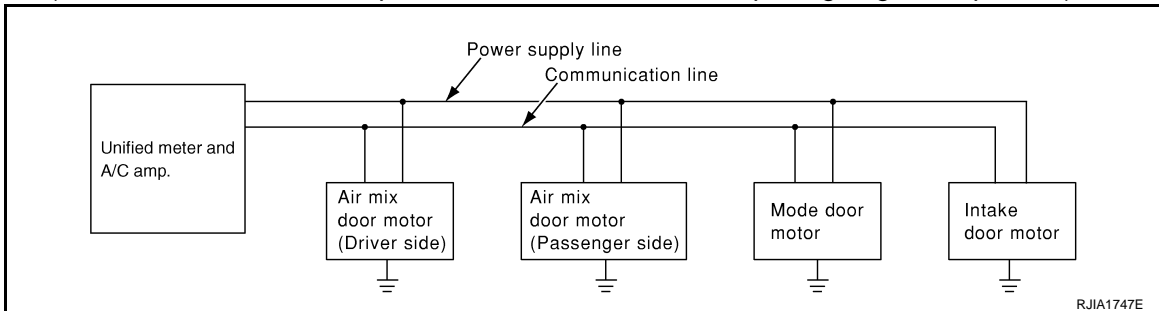

OPERATION

The unified meter and A/C amp. sends mode door, air mix door and intake door opening angle data to the mode door motor LCU, air mix door motor LCU and intake door motor LCU.

The mode door motor, air mix door motor and intake door motor read their respective signals according to the address signal. Opening angle indication signals are sent from the unified meter and A/C amp. to each of the motors and are compared by the LCUs in each motor with the existing position and opening angles. Subsequently, HOT/COLD, DEFROST/VENT or FRESH/RECIRCULATION operation is selected. When the selected angle position is reached a reply is sent from the motors back to the unified meter and A/C amp.

AIR CONDITIONER CONTROL

< SERVICE INFORMATION >

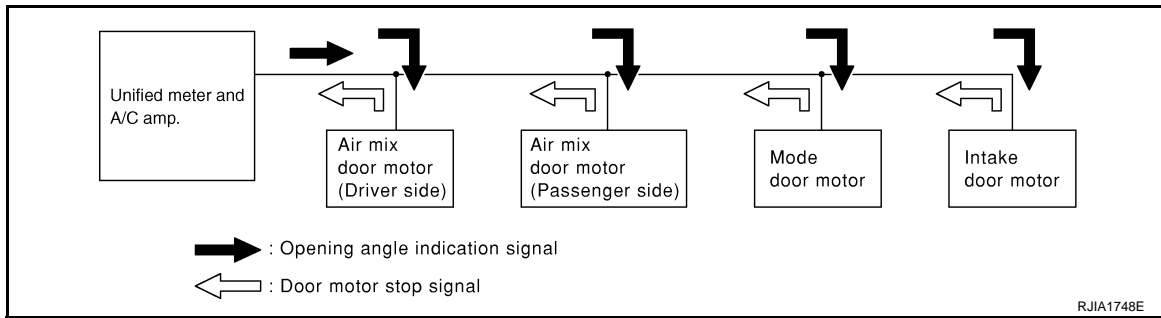

TRANSMISSION DATA AND TRANSMISSION ORDER

Unified meter and A/C amp. data is transmitted consecutively to each of the door motors following the form shown in figure below.

Start: Initial compulsory signal sent to each of the door motors.

Address: Data sent from the unified meter and A/C amp. is selected according to data-based decisions made by the air mix door motor, mode door motor and intake door motor.

If the addresses are identical, the opening angle data and error check signals are received by the door motor LCUs. The LCUs then make the appropriate error decision. If the opening angle data is usual, door control begins.

If an error exists, the received data is rejected and corrected data received. Finally, door control is based upon the corrected opening angle data.

Opening angle:

Data that shows the indicated door opening angle of each door motor.

Error check:

Procedure by which sent and received data is checked for errors. Error data is then compiled. The error check prevents corrupted data from being used by the air mix door motor, mode door motor and intake door motor. Error data can be related to the following symptoms.

- Unusual electrical frequency
- Poor electrical connections
- Signal leakage from transmission lines
- Signal level fluctuation

Stop signal:

At the end of each transmission, a stop operation, in-operation, or internal error message is delivered to the unified meter and A/C amp. This completes one data transmission and control cycle.

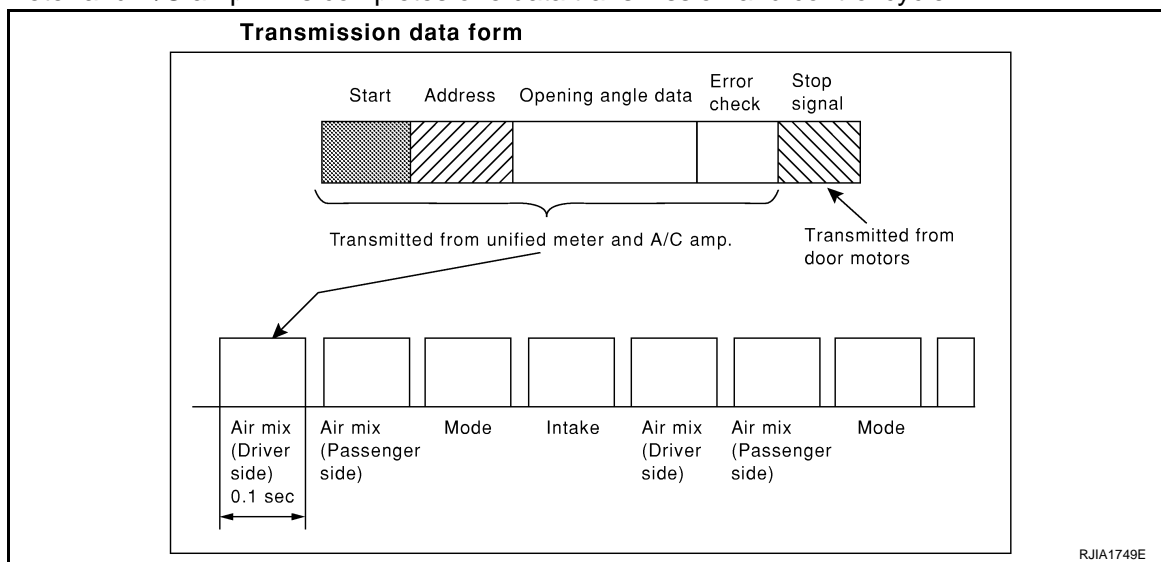

AIR MIX DOOR CONTROL (AUTOMATIC TEMPERATURE CONTROL)

The air mix door is automatically controlled so that in-vehicle temperature is maintained at a predetermined value by: The temperature setting, ambient temperature, in-vehicle temperature and amount of sunload.

FAN SPEED CONTROL

Blower speed is automatically controlled based on temperature setting, ambient temperature, in-vehicle temperature, intake temperature, amount of sunload and air mix door position.

AIR CONDITIONER CONTROL

< SERVICE INFORMATION >

When pressing AUTO switch, the blower motor starts to gradually increase air flow volume. When engine coolant temperature is low, the blower motor operation is delayed to prevent cool air from flowing.

INTAKE DOOR CONTROL

The intake doors are automatically controlled by: The temperature setting, ambient temperature, in-vehicle temperature, intake temperature, amount of sunload and ON-OFF operation of the compressor.

OUTLET DOOR CONTROL

The outlet door is automatically controlled by: The temperature setting, ambient temperature, in-vehicle temperature, intake temperature and amount of sunload.

MAGNET CLUTCH CONTROL

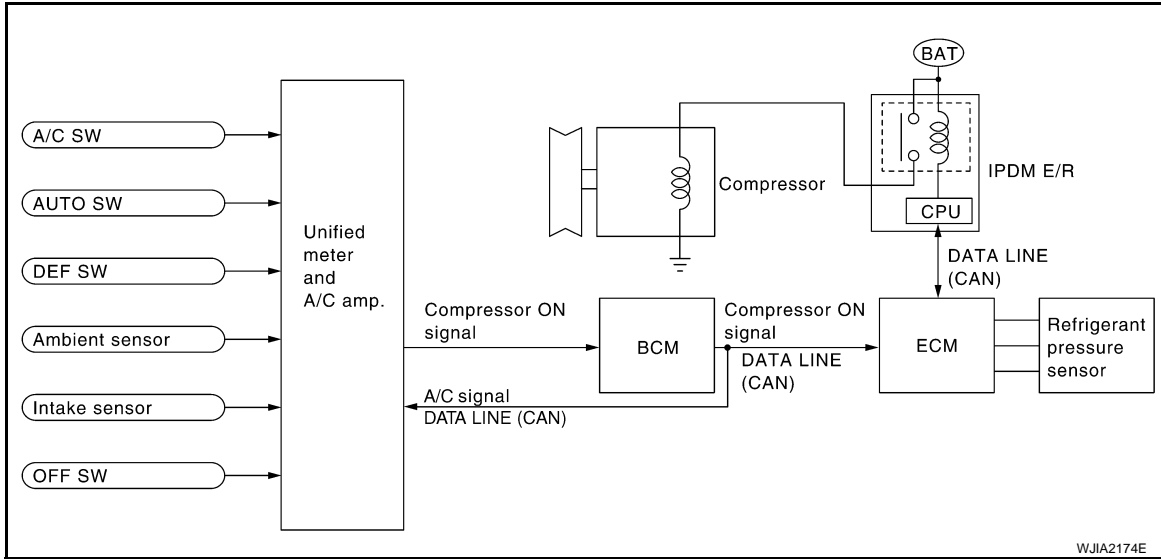

When A/C switch or DEF switch is pressed, unified meter and A/C amp. inputs compressor ON signal to BCM. BCM sends compressor ON signal to ECM, and unified meter and amp. via CAN communication line. ECM judges whether compressor can be turned ON, based on each sensor status (refrigerant-pressure sensor signal, throttle angle, etc.). If it judges compressor can be turned ON, it sends compressor ON signal to IPDM E/R, via CAN communication line. Upon receipt of compressor ON signal from ECM, IPDM E/R turns air conditioner relay ON to operate compressor.

SELF-DIAGNOSTIC SYSTEM

The self-diagnostic system is built into the unified meter and A/C amp. to quickly locate the cause of symptoms.

Description of Control System

INFOID:000000001721292

The control system consists of input sensors, switches, the unified meter and A/C amp. (microcomputer) and outputs.

AIR CONDITIONER CONTROL

< SERVICE INFORMATION >

The relationship of these components is shown in the figure below:

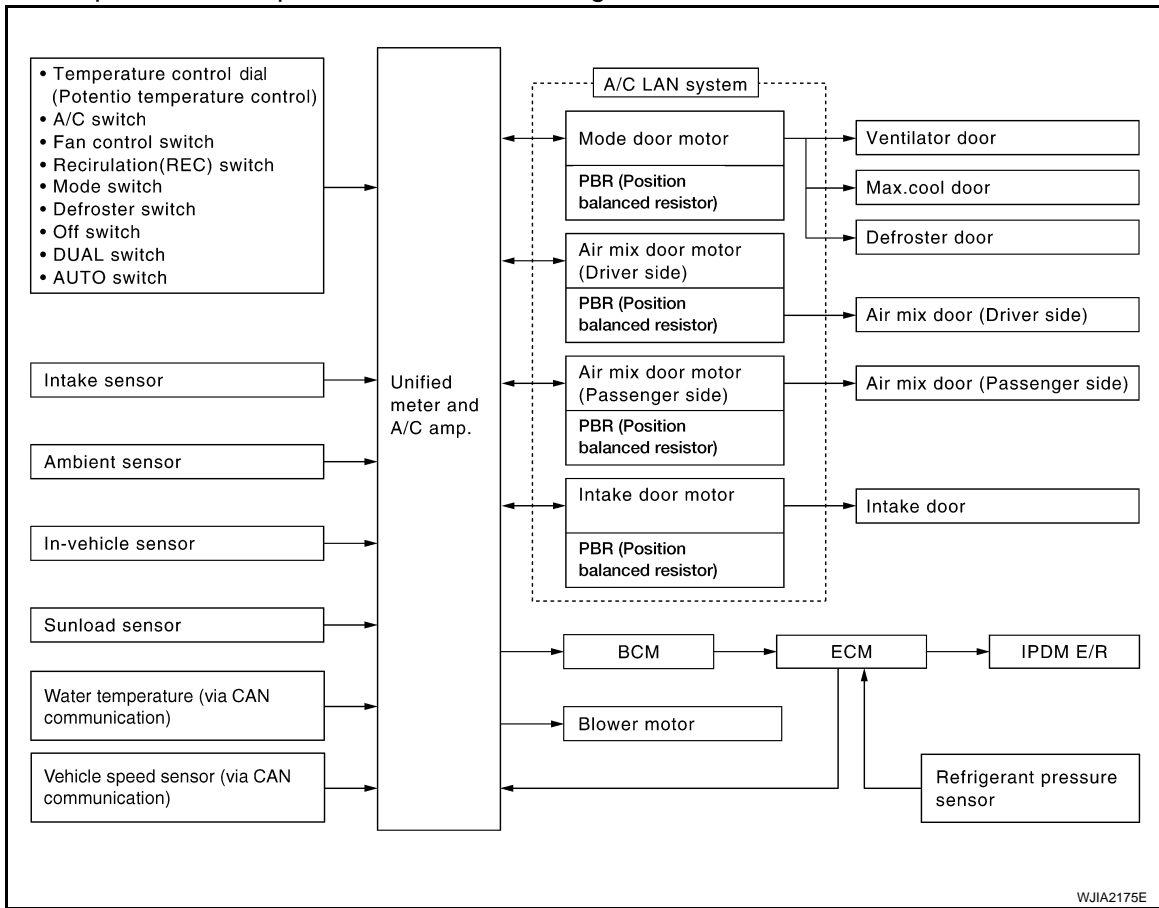

Control Operation

INFOID:000000001721293

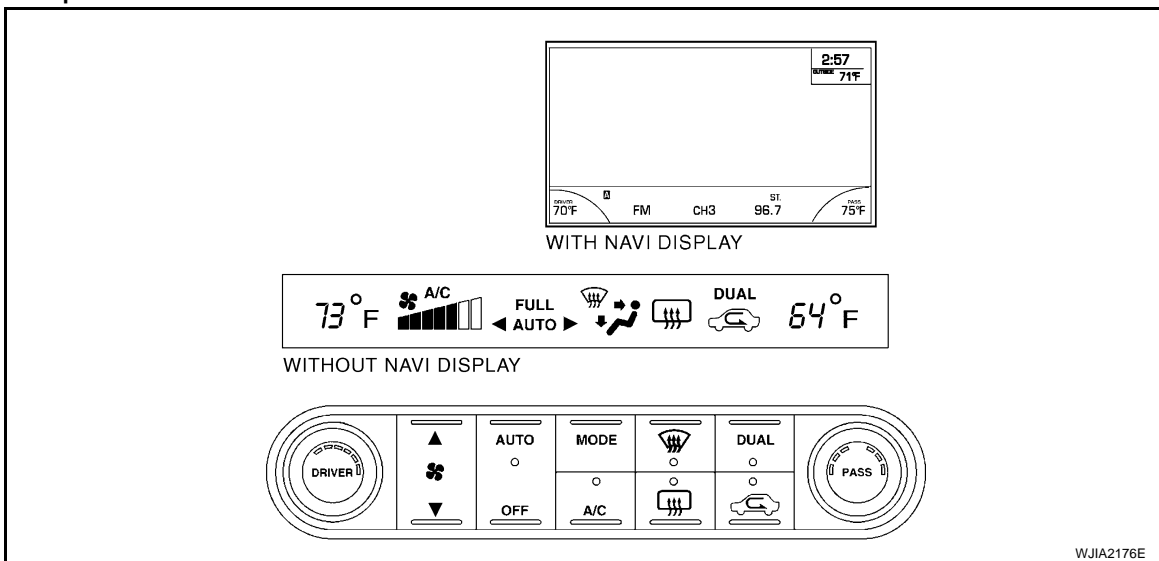

DISPLAY SCREEN

Displays the operational status of the system.

AUTO SWITCH

- The compressor, intake doors, air mix doors, outlet doors and blower speed are automatically controlled so that the in-vehicle temperature will reach, and be maintained at the set temperature selected by the operator.
- When pressing AUTO switch, air inlet, air outlet, fan speed, and discharge air temperature are automatically controlled.

TEMPERATURE CONTROL DIAL (DRIVER SIDE)

AIR CONDITIONER CONTROL

< SERVICE INFORMATION >

Increases or decreases the set temperature.

TEMPERATURE CONTROL DIAL (PASSENGER SIDE)

- Increases or decreases the set temperature.
- When the temperature dial is turned, the dual switch indicator will automatically illuminate.

RECIRCULATION () SWITCH

- When REC switch is ON, REC switch indicator turns ON, air inlet is set to REC and A/C compressor will turn ON.
- REC switch is not operated when DEF switch is turned ON, or at the D/F position.

DEFROSTER () (DEF) SWITCH

Positions the air outlet doors to the defrost position. Also positions the intake doors to the outside air position. The compressor remains ON until the ignition is turned OFF.

REAR WINDOW DEFOGGER SWITCH

When illumination is ON, rear window is defogged.

OFF SWITCH

The compressor and blower are OFF, the intake doors are set to the outside air position, and the air outlet doors are set to the foot (75% foot and 25% defrost) position.

A/C SWITCH

The compressor is ON or OFF.

(Pressing the A/C switch when the AUTO switch is ON will turn off the A/C switch and compressor.)

MODE SWITCH

Controls the air discharge outlets.

BLOWER CONTROL SWITCH

Manually control the blower speed. Seven speeds are available for manual control (as shown on the display screen).

DUAL SWITCH (WITH LEFT AND RIGHT VENTILATION TEMPERATURE SEPARATE CONTROL SYSTEM)

- When the DUAL switch indicator is not illuminated and the DUAL switch is pressed, the driver-side setting temperature and passenger-side setting temperature can each be set independently.
- When DUAL switch indicator is illuminated and the DUAL switch is pressed, the driver-side setting temperature is applied to both sides.

Fail-Safe Function

INFOID:000000001721294

- If a communication error exists between unified meter and A/C amp. and front air control for 30 seconds or longer, air conditioner is controlled under following conditions:
 - Compressor: ON
 - Air outlet: AUTO
 - Air inlet: () Fresh
 - Blower fan speed: AUTO
 - Set temperature: Setting before communication error occurs.

Discharge Air Flow

INFOID:000000001721295

AIR CONDITIONER CONTROL

< SERVICE INFORMATION >

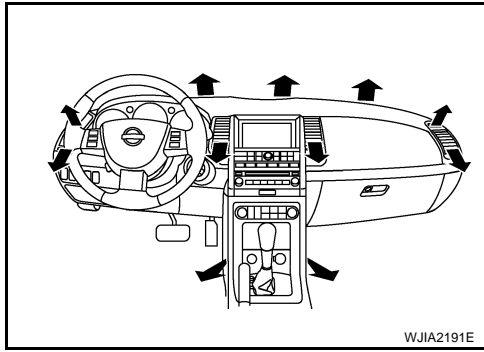

Mode door position	Air outlet/distribution		
	Vent	Foot	Defroster
	100%	0%	—
	60%	40%	—
	—	75% (100%)	25% (—)
	—	60%	40%
	—	—	100%

() : Manually control

System Description

INFOID:000000001721296

SWITCHES AND THEIR CONTROL FUNCTION

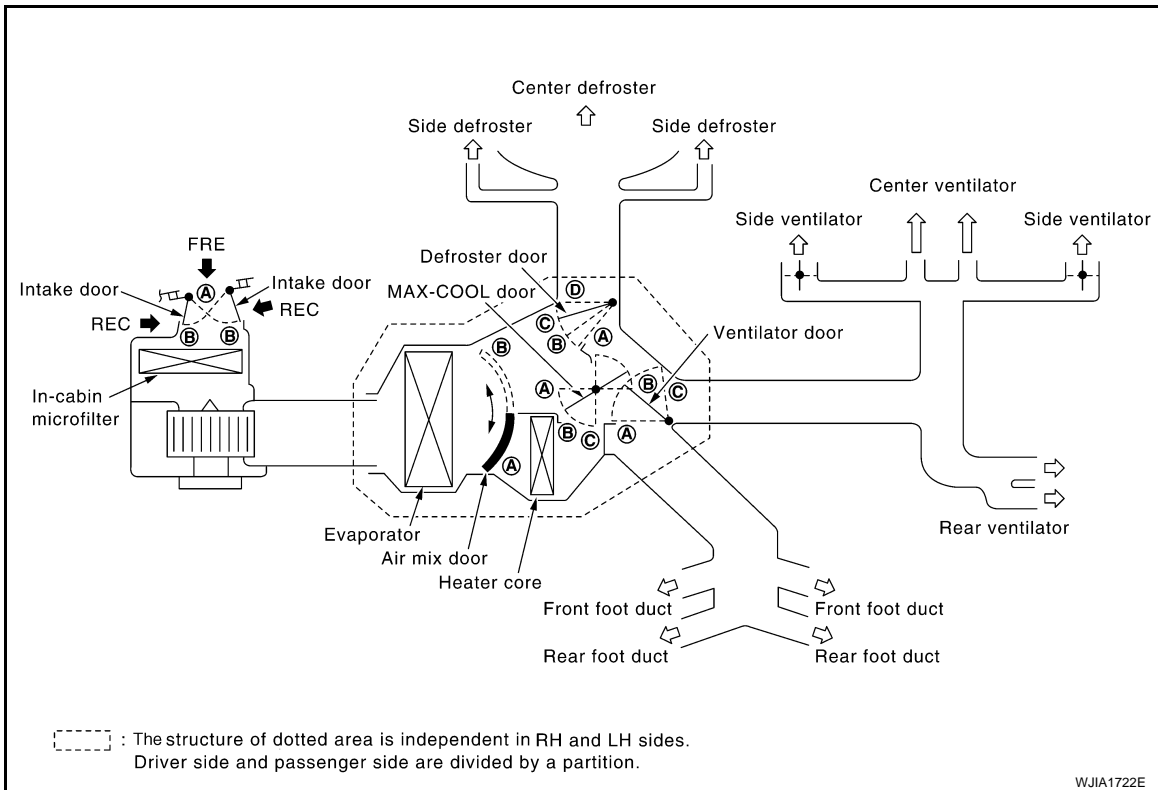











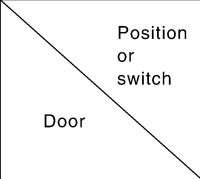

WJIA1722E

A
B
C
D
E
F
G
H
I
K
L
M
N
O
P

ATC

AIR CONDITIONER CONTROL

< SERVICE INFORMATION >

Door 	MODE SW				DEF SW		AUTO SW 	REC SW		Temperature control			OFF SW 
	VENT	B/L	FOOT	D/F	ON	OFF		ON	OFF				
										18°C (60°F)	~	32°C (90°F)	
Ventilator door	(A)	(B)	(C)	(C)	(C)	—	AUTO	—	—	—	—	(C)	
MAX-COOL door	(A)	(B)	(B)	(B)	(C)	—		—	—	—	—	(B)	
Defroster door	(D)	(D)	(D) ^{*1}	(C) ^{*1}	(B)	(A)		—	—	—	—	(C)	
Intake door	—				(B)	—	—	(A) ^{*2}	(B) ^{*2}	—	—	(B)	
Air mix door	—				—	—	AUTO	—	—	(A)	AUTO	(B)	—

*1: This position is selected only when the mode door is automatically controlled.
*2: Inlet status is displayed even during automatic control.

WJIA2181E

CAN Communication System Description

INFOID:000000001721297

Refer to [LAN-3](#).

TROUBLE DIAGNOSIS

< SERVICE INFORMATION >

TRouble DIAGNOSIS

CONSULT-III Function (BCM)

INFOID:000000001721298

CONSULT-III can display each diagnostic item using the diagnostic test modes shown following.

BCM diagnostic test item	Diagnostic mode	Description
Inspection by part	WORK SUPPORT	Supports inspections and adjustments. Commands are transmitted to the BCM for setting the status suitable for required operation, input/output signals are received from the BCM and received date is displayed.
	DATA MONITOR	Displays BCM input/output data in real time.
	ACTIVE TEST	Operation of electrical loads can be checked by sending drive signal to them.
	SELF-DIAG RESULTS	Displays BCM self-diagnosis results.
	CAN DIAG SUPPORT MNTR	The result of transmit/receive diagnosis of CAN communication can be read.
	ECU PART NUMBER	BCM part number can be read.
	CONFIGURATION	Performs BCM configuration read/write functions.

DATA MONITOR

Display Item List

Monitor item name "operation or unit"	Contents
IGN ON SW "ON/OFF"	Displays "IGN Position (ON)/OFF, ACC Position (OFF)" status as judged from ignition switch signal.
FAN ON SIG "ON/OFF"	Displays "FAN (ON)/FAN (OFF)" status as judged from blower fan motor switch signal.
AIR COND SW "ON/OFF"	Displays "AIR COND (ON)/AIR COND (OFF)" status as judged from air conditioner switch signal.

How to Perform Trouble Diagnosis for Quick and Accurate Repair

INFOID:000000001721299

WORK FLOW

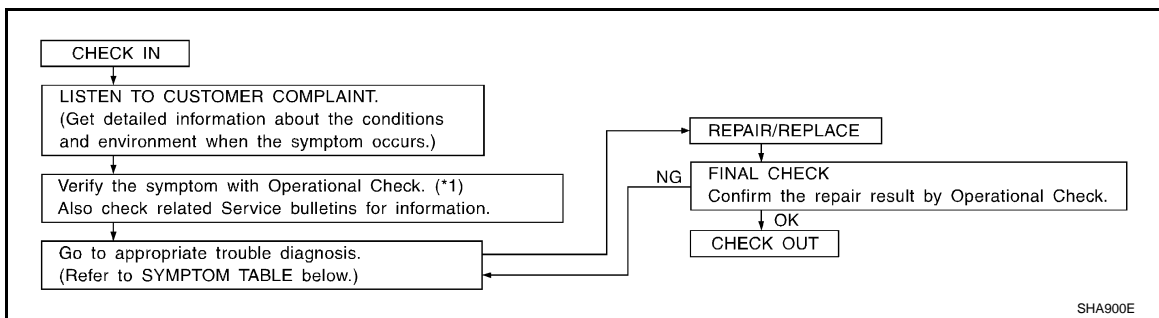

*1 [ATC-40. "Operational Check"](#)

SYMPTOM TABLE

TROUBLE DIAGNOSIS

< SERVICE INFORMATION >

Symptom	Reference Page	
A/C system is completely inoperative.	Go to Trouble Diagnosis Procedure for A/C System.	ATC-42. "Power Supply and Ground Circuit for Front Air Control and Unified Meter and A/C Amp"
A/C system is partially inoperative.	Go to Diagnostic Procedure for Front Air Control.	ATC-90. "Front Air Control Self - Diagnosis"
A/C display inoperative.	Go to Diagnostic Procedure for A/C Display.	AV-133. "On Board Self-Diagnosis Function" (with NAVI) ATC-89. "A/C Display (without NAVI)"
Air outlet does not change.	Go to Trouble Diagnosis Procedure for Mode Door Motor. (LAN)	ATC-47. "Mode Door Motor Circuit"
Mode door motor does not operate normally.		
Discharge air temperature does not change.	Go to Trouble Diagnosis Procedure for Air Mix Door Motor. (LAN)	ATC-50. "Air Mix Door Motor Circuit"
Air mix door motor does not operate normally.		
Intake door does not change.	Go to Trouble Diagnosis Procedure for Intake Door Motor. (LAN)	ATC-53. "Intake Door Motor Circuit"
Intake door motor does not operate normally.		
Blower motor operation is malfunctioning.	Go to Trouble Diagnosis Procedure for Blower Motor.	ATC-55. "Blower Motor Circuit"
Blower motor operation is malfunctioning under out of starting fan speed control.		
Magnet clutch does not engage.	Go to Trouble Diagnosis Procedure for Magnet Clutch.	ATC-61. "Magnet Clutch Circuit"
Insufficient cooling	Go to Trouble Diagnosis Procedure for Insufficient Cooling.	ATC-65. "Insufficient Cooling"
Insufficient heating	Go to Trouble Diagnosis Procedure for Insufficient Heating.	ATC-73. "Insufficient Heating"
Noise	Go to Trouble Diagnosis Procedure for Noise.	ATC-74. "Noise"
Self-diagnosis cannot be performed.	Go to Trouble Diagnosis Procedure for Self-diagnosis.	ATC-75. "Self-Diagnosis"
Memory function does not operate.	Go to Trouble Diagnosis Procedure for Memory Function.	ATC-77. "Memory Function"

Component Parts and Harness Connector Location

INFOID:000000001721300

ENGINE COMPARTMENT

TROUBLE DIAGNOSIS

< SERVICE INFORMATION >

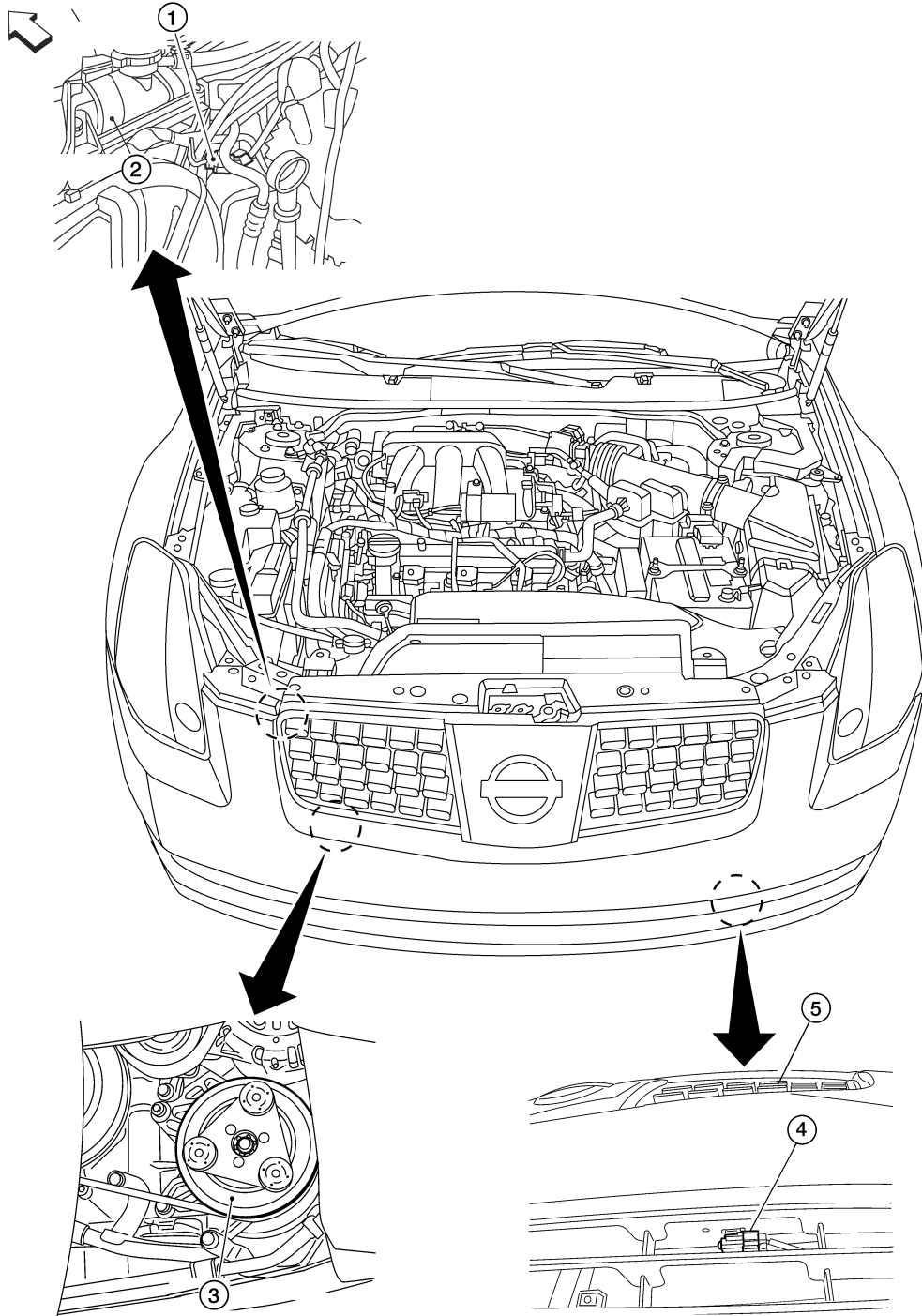

1. Refrigerant pressure sensor E11

2. Radiator

3. A/C compressor F3 (view from tire housing RH)

4. Ambient sensor E1

5. Grille

PASSENGER COMPARTMENT

A
B
C
D
E
F
G
H
I
ATC
K
L
M
N
O
P

WJIA1906E

TROUBLE DIAGNOSIS

< SERVICE INFORMATION >

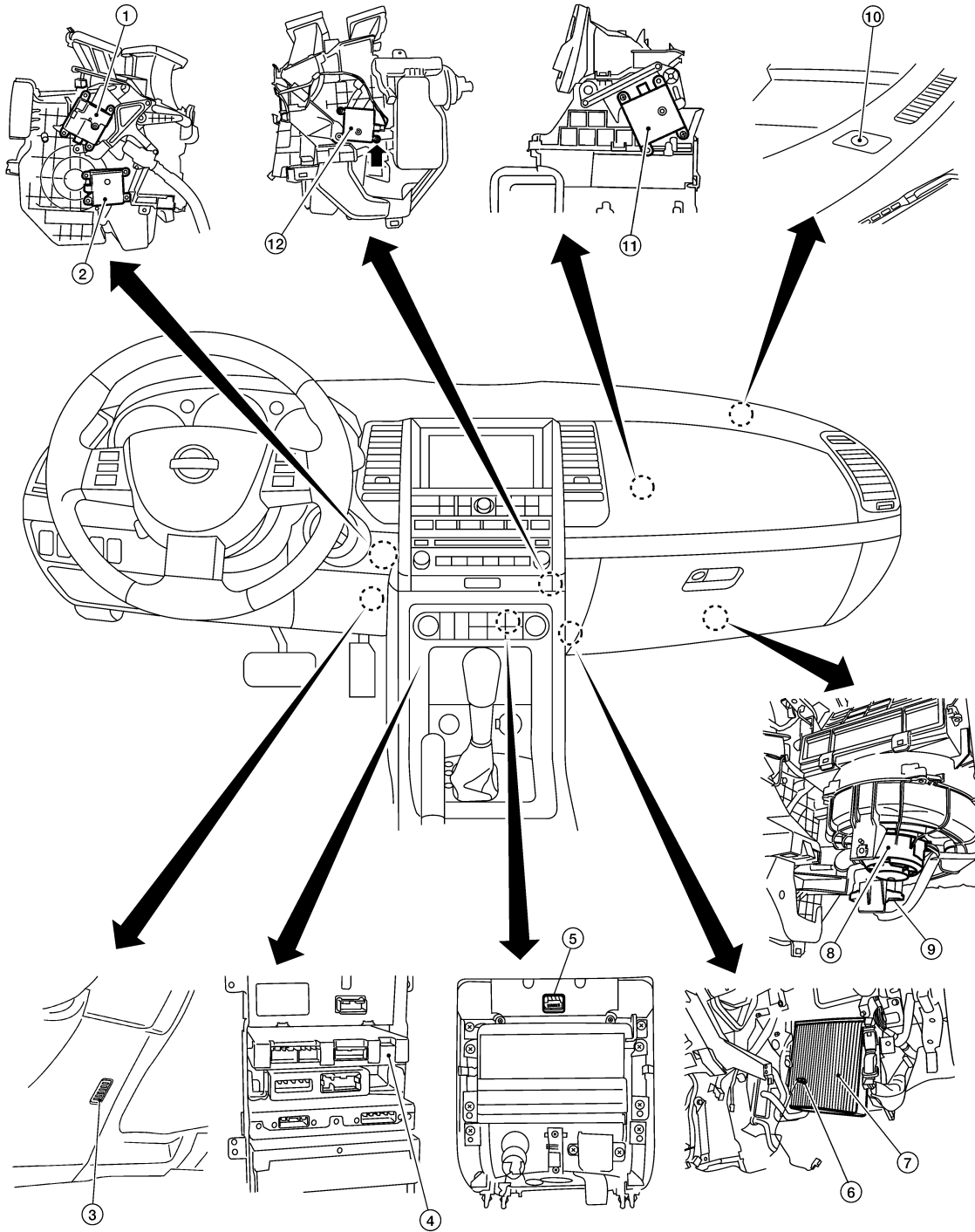

WJIA2182E

- | | | |
|---|------------------------------------|--|
| 1. Mode door motor M40 | 2. Air mix door motor (driver) M39 | 3. In-vehicle sensor M32 |
| 4. Unified meter and A/C amp. M49, M50, M89 | 5. Front air control M201 | 6. Intake sensor M33 |
| 7. Evaporator | 8. Blower motor M62 | 9. Fan control amp. M64 |
| 10. Sunload sensor M65 | 11. Intake door motor M58 | 12. Air mix door motor (passenger) M87 |

TROUBLE DIAGNOSIS

< SERVICE INFORMATION >

Schematic

INFOID:000000001721301

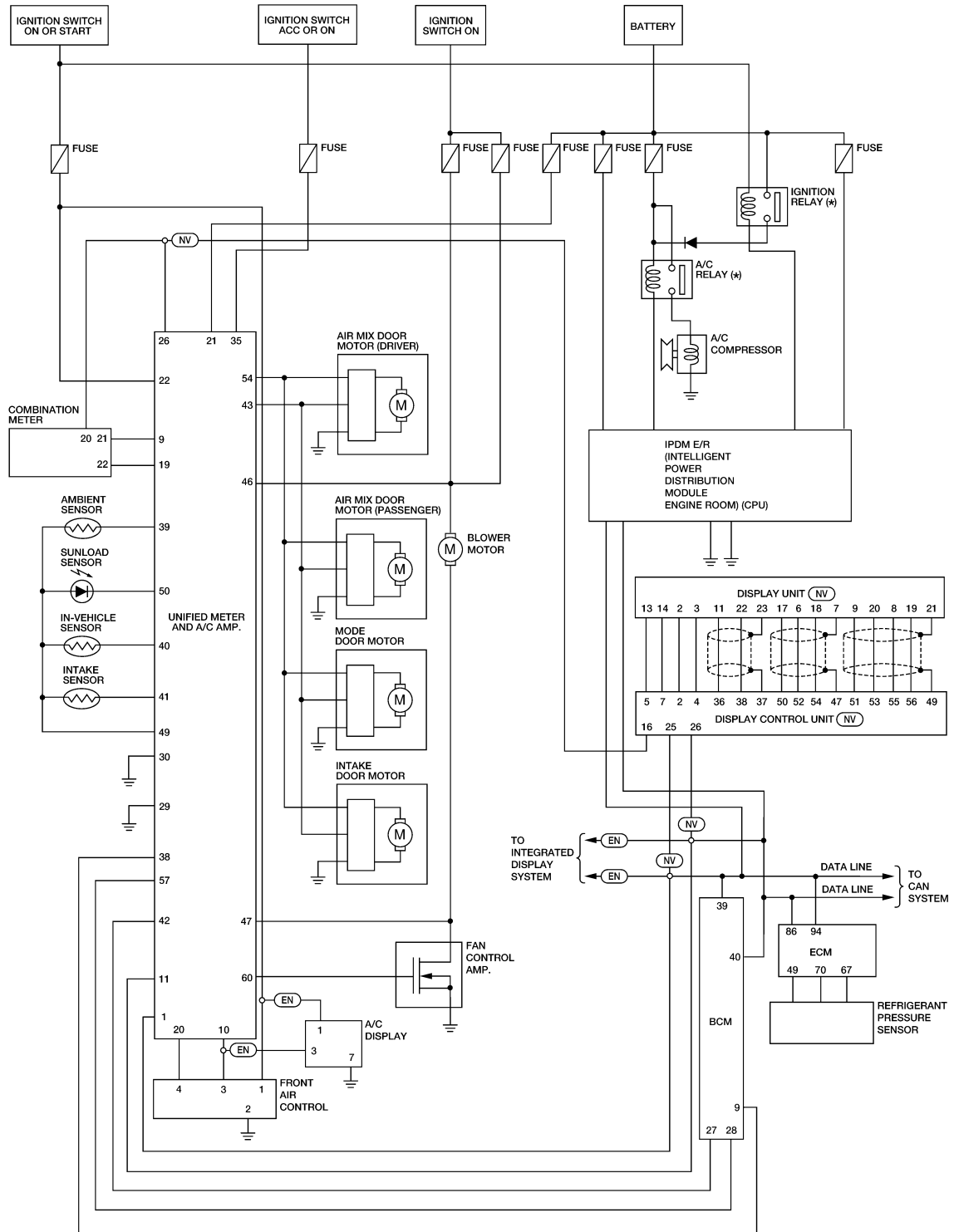

(EN) : WITHOUT NAVI
(NV) : WITH NAVI

*: THIS RELAY IS BUILT INTO IPDM E/R (INTELLIGENT POWER DISTRIBUTION MODULE ENGINE ROOM)

WJWA0441E

A
B
C
D
E
F
G
H
I
K
L
M
N
O
P

ATC

TROUBLE DIAGNOSIS

< SERVICE INFORMATION >

Wiring Diagram - A/C,A -

INFOID:000000001721302

ATC-A/C,A-01

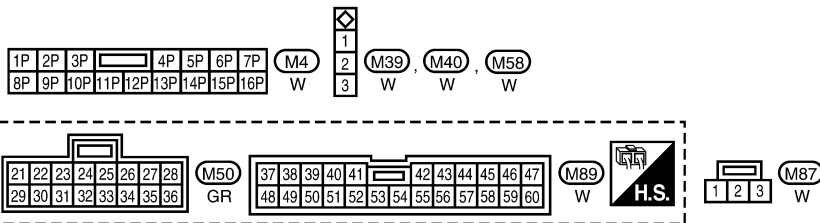
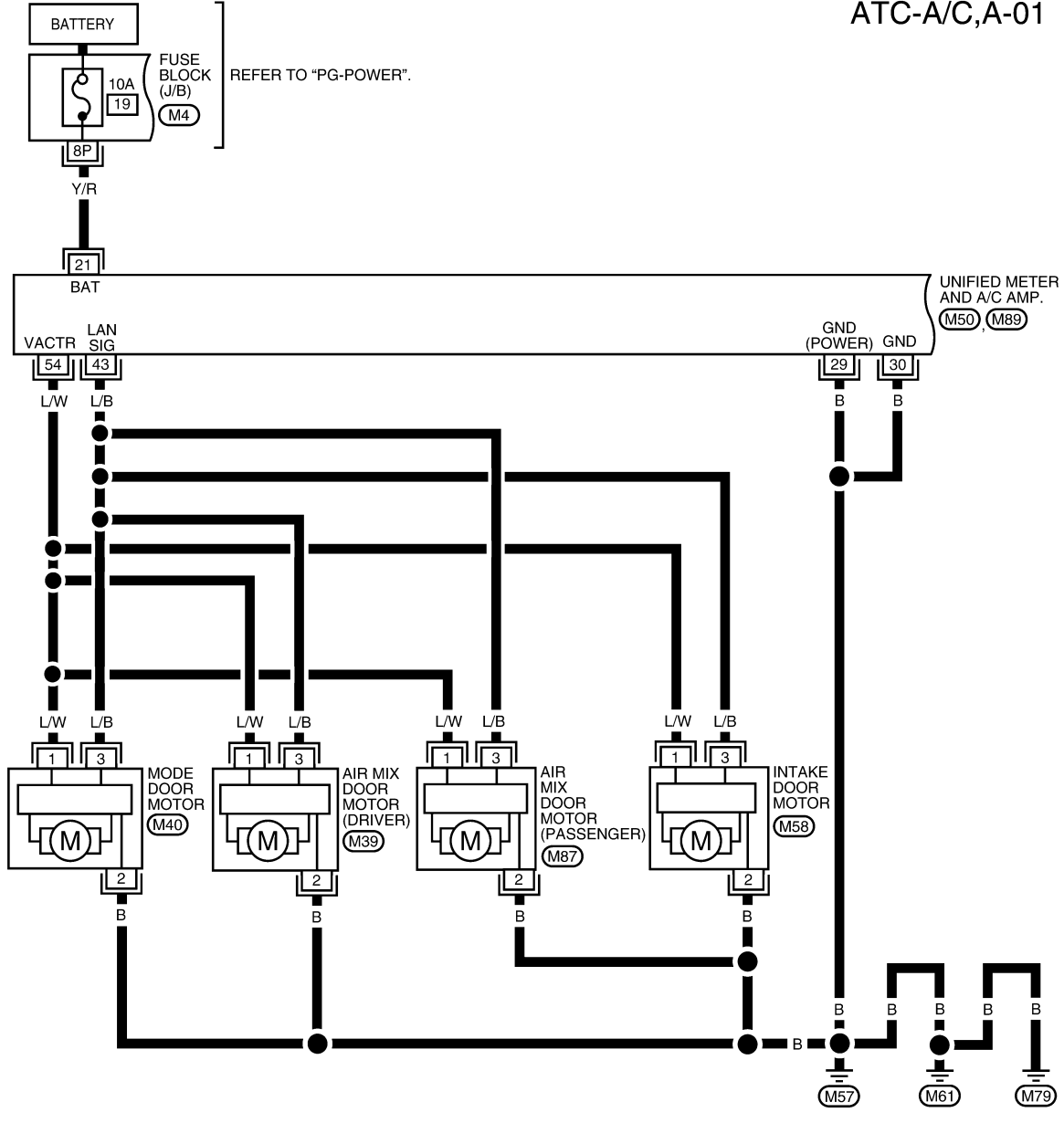

WJWA0442E

TROUBLE DIAGNOSIS

< SERVICE INFORMATION >

ATC-A/C,A-02

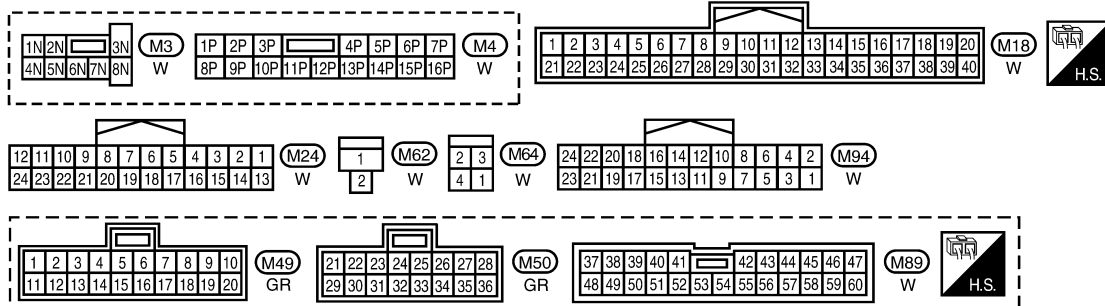
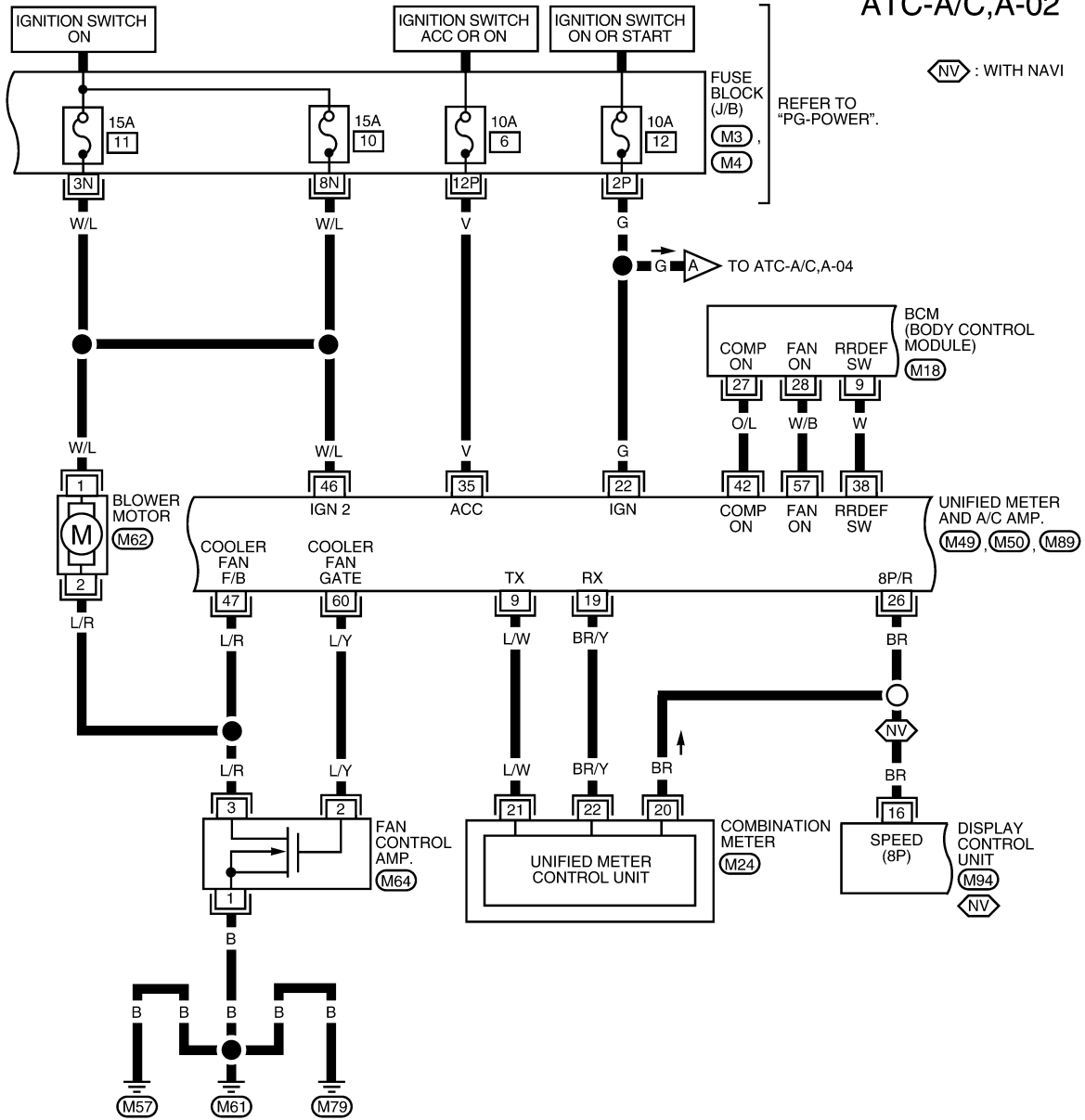

WJWA0443E

TROUBLE DIAGNOSIS

< SERVICE INFORMATION >

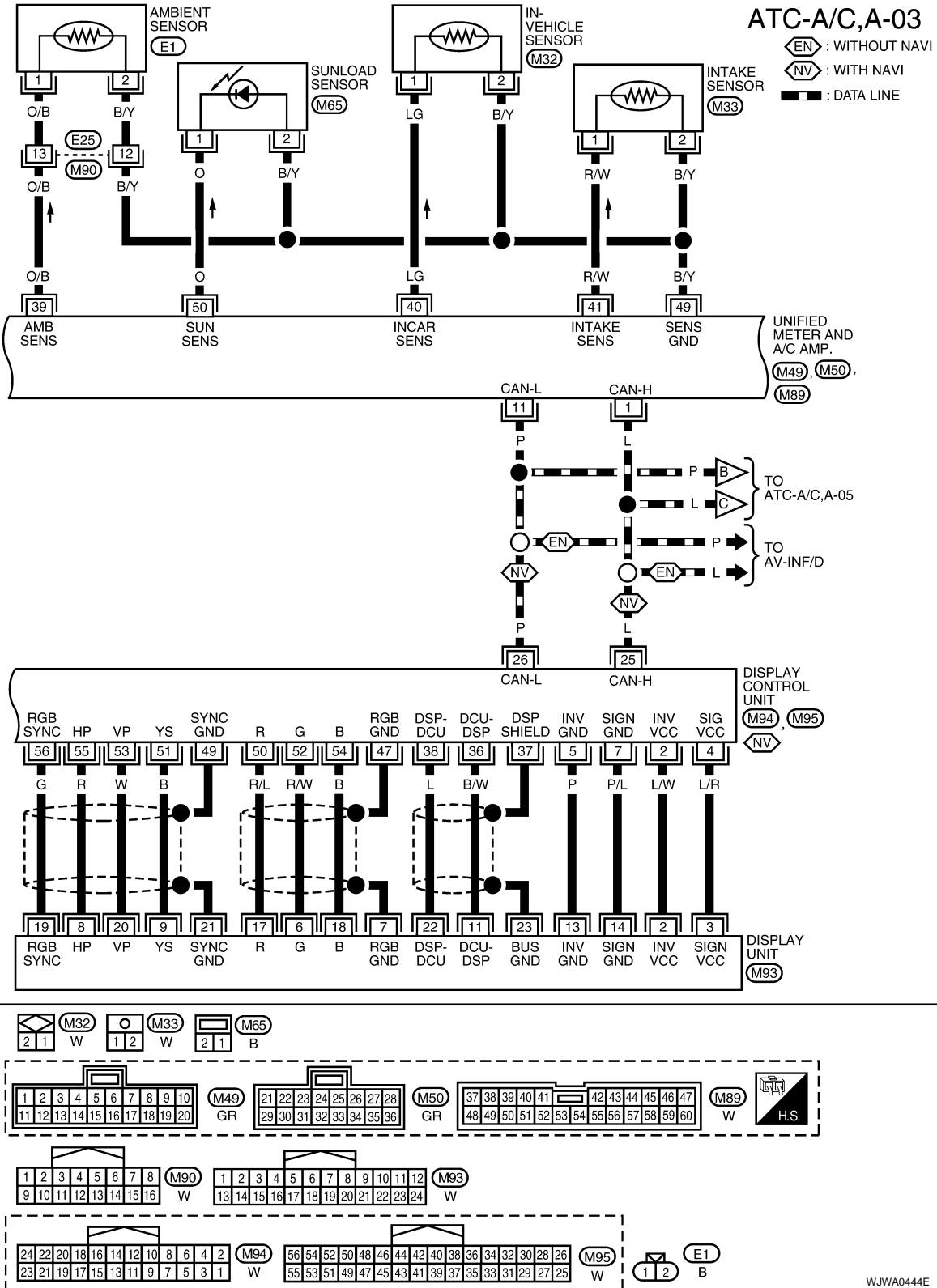

WJWA0444E

TROUBLE DIAGNOSIS

< SERVICE INFORMATION >

ATC-A/C,A-04

ⓂEN: WITHOUT NAVI

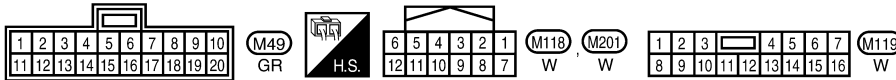
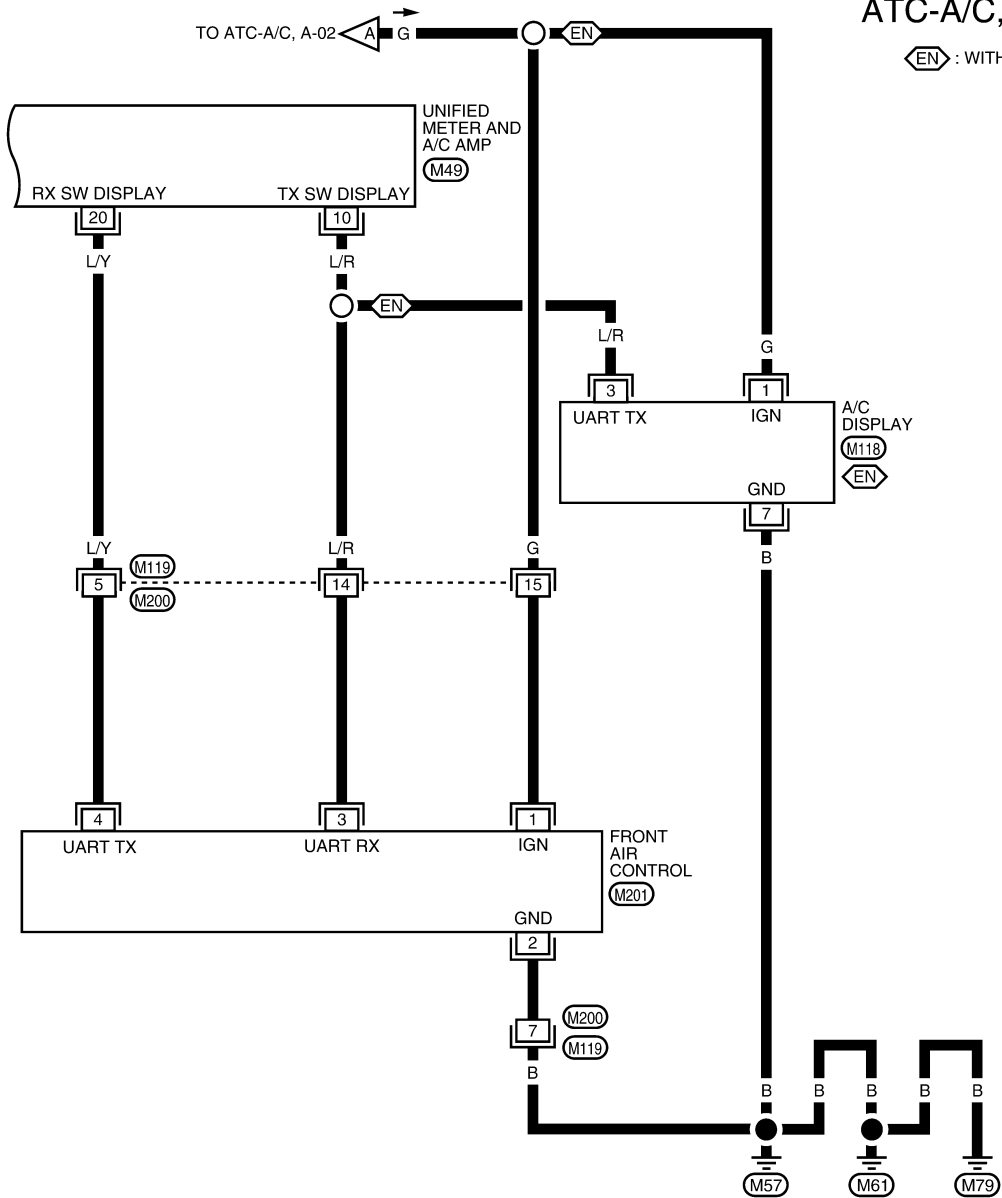

A
B
C
D
E
F
G
H
I
ATC
K
L
M
N
O
P

LJWA0014E

TROUBLE DIAGNOSIS

< SERVICE INFORMATION >

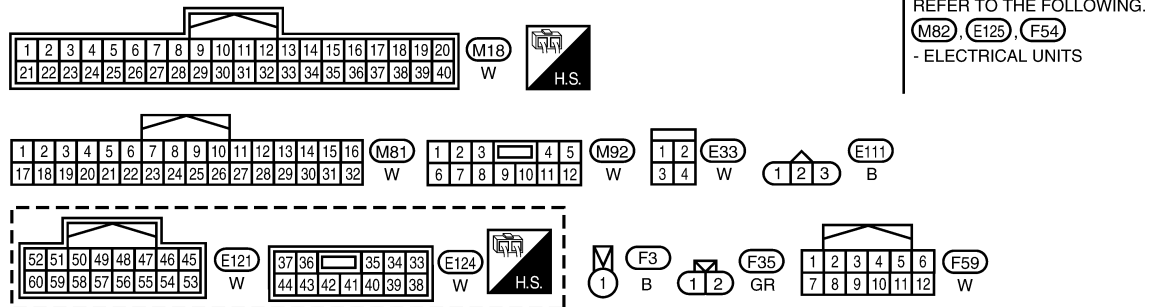
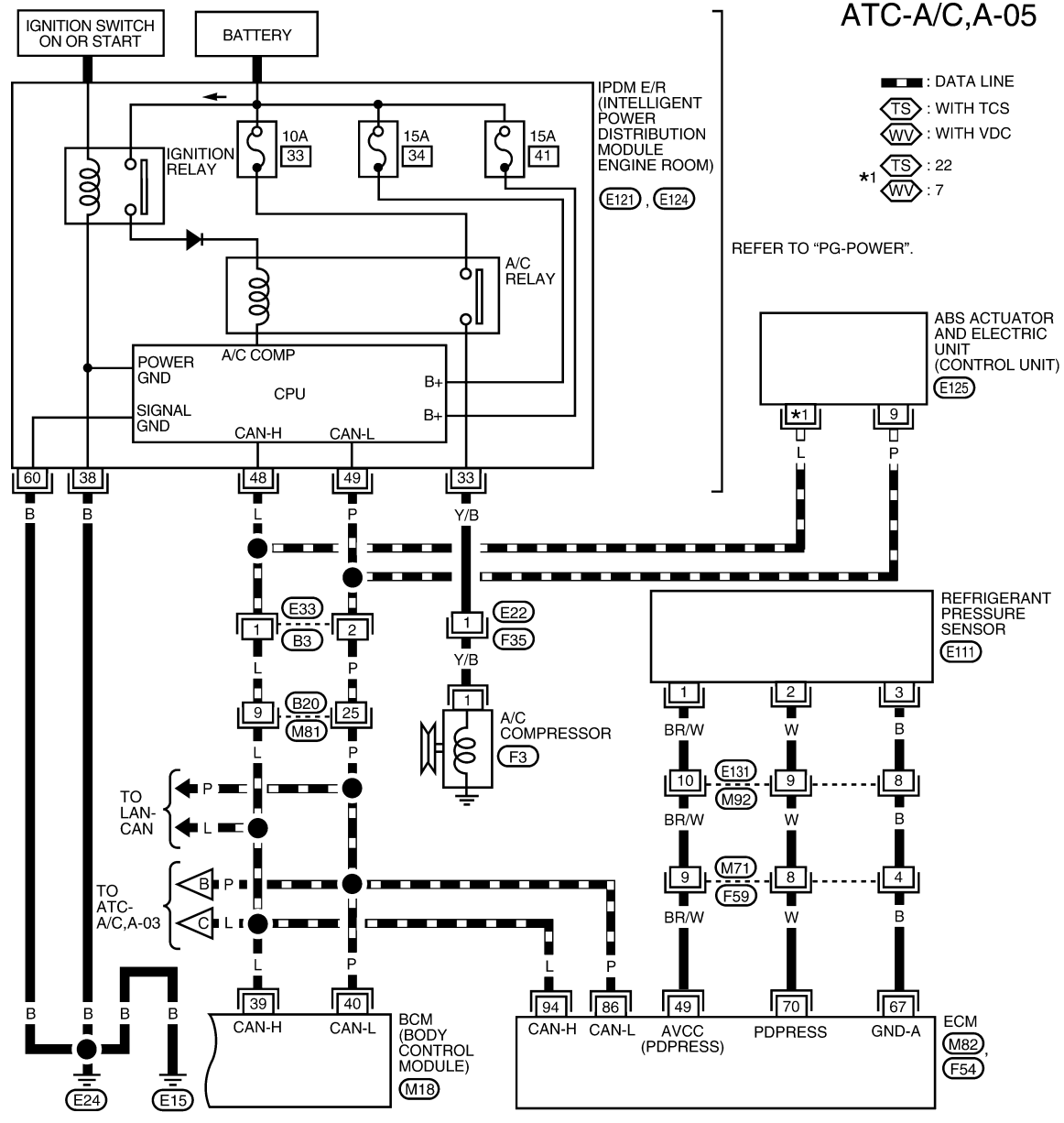

Unified Meter and A/C Amp. Terminal and Reference Value

Refer to [DI-28, "Terminal and Reference Value for Unified Meter and A/C Amp."](#)

A/C System Self-Diagnosis Function

DESCRIPTION

WJWA0445E

INFOID:000000001721303

INFOID:000000001721304

TROUBLE DIAGNOSIS

< SERVICE INFORMATION >

The self-diagnostic system diagnoses sensors, door motors, blower motor, etc. by system line. Refer to applicable sections (items) for details. To shift from usual control to the self-diagnostic system refer to "FUNCTION CONFIRMATION PROCEDURE".

FUNCTION CONFIRMATION PROCEDURE

1. ENTER SELF-DIAGNOSTIC MODE

CAUTION:

- If battery voltage drops below 12V during diagnosis STEP 3, actuator speed becomes slower and as a result, the system may generate an error even when operation is usual. To avoid this, start engine before performing this diagnosis.

NOTE:

Former STEP 1 (LEDs and display screen are checked) no longer exist in this self-diagnosis function.

1. Start engine.
2. Within 10 seconds after starting engine, press OFF switch for at least 5 seconds.

NOTE:

Self-diagnostic mode can be canceled by either pressing AUTO switch, turning the ignition switch OFF, or pressing the BACK button if equipped with NAVI.

>> GO TO 2.

2. SELF-DIAGNOSIS STEP 2: SENSOR CIRCUITS ARE CHECKED FOR OPEN OR SHORT CIRCUIT

NOTE:

When conducting test indoors, aim a light (more than 60W) at sunload sensor, otherwise Code No. 25 will indicate despite that sunload sensor is functioning properly

Does code No. 20 appear on the display 25 seconds after "2" is illuminated?

- YES >> GO TO 3.
NO >> GO TO 13.

3. CHECK OPERATION OF TEMPERATURE CONTROL DIAL

Rotate the temperature control dial (driver) clockwise.

Does the temperature control dial advance to self-diagnosis STEP 3?

- YES >> GO TO 4.
NO >> Malfunctioning temperature control dial.
>> Check front air control. Refer to [ATC-90. "Front Air Control Self - Diagnosis"](#).

4. CHECK TO RETURN SELF-DIAGNOSIS STEP 2

Rotate the temperature control dial (driver) counterclockwise.

Does the temperature control dial return to self-diagnosis STEP 2?

- YES >> GO TO 5.
NO >> Malfunctioning temperature control dial.
>> Check front air control. Refer to [ATC-90. "Front Air Control Self - Diagnosis"](#).



5. SELF-DIAGNOSIS STEP 3: MODE DOOR AND INTAKE DOOR POSITIONS ARE CHECKED

Rotate the temperature control dial (driver) clockwise to STEP 3.

Does code No. 30 appear on the display 50 seconds after "3" is illuminated?

- YES >> GO TO 6.
NO >> GO TO 14.

6. STEP 4: CHECK OPERATION OF EACH ACTUATOR

1. Rotate the temperature control dial (driver) clockwise to STEP 4.
2. Press  (DEF) switch. Code No. "41" is indicated on the display. Continue to press  (DEF) switch to cycle through each actuator test (41 to 46).

TROUBLE DIAGNOSIS

< SERVICE INFORMATION >

>> GO TO 7.

7. CHECK ACTUATORS

Refer to the following chart and confirm discharge air flow, air temperature, blower motor voltage and compressor operation.

Discharge air flow			
Mode door position	Air outlet/distribution		
	Vent	Foot	Defroster
	100%	–	–
	60%	40%	–
	–	75%(100%)	25% (–)
	–	60%	40%
	–	–	100%

() : Manually control RJA1761E

Actuator test code no.	41	42	43	44	45	46
Mode door position	VENT	B/L 1	B/L 2	D/F1*1	D/F	DEF
Intake door position	REC	REC	20%FRE	FRE	FRE	FRE
Air mix door position	FULL COLD	FULL COLD	FULL HOT	FULL HOT	FULL HOT	FULL HOT
Blower motor voltage (approx.)	5V	11.75V	8.5V	8.5V	8.5V	11.75V
Compressor	ON	ON	OFF	OFF	ON	ON

Checks must be made visually, by listening to any noise, or by touching air outlets with your hand, etc. for improper operation.

*1: D/F1 automatically controls the mode door position. Refer to the Discharge air flow table "AUXILIARY MECHANISM: DEFROST/FOOT POSITION SETTING TRIMMER".

OK or NG

OK >> GO TO 8.

- NG >>
- Air outlet does not change.
GO TO [ATC-47. "Mode Door Motor Circuit"](#).
 - Intake door does not change.
GO TO [ATC-53. "Intake Door Motor Circuit"](#).
 - Blower motor operation is malfunctioning.
GO TO [ATC-55. "Blower Motor Circuit"](#).
 - Magnet clutch does not engage.
GO TO [ATC-61. "Magnet Clutch Circuit"](#).
 - Discharge air temperature does not change.
GO TO [ATC-50. "Air Mix Door Motor Circuit"](#).

8. SELF-DIAGNOSIS STEP 5: TEMPERATURE OF EACH SENSOR IS CHECKED

1. Rotate the temperature control dial clockwise (driver) to STEP 5.
2. Code No. 51 appears on the display.

>> GO TO 9.

9. CHECK AMBIENT SENSOR

Press (DEF) switch one time. Temperature detected by ambient sensor is indicated on the display (°F for U.S.A. model, °C for Canada and Mexico models).

NOTE:

If temperature shown on display greatly differs from actual temperature, check sensor circuit first, then inspect sensor.

OK or NG

OK >> GO TO 10.

NG >> GO TO [ATC-77. "Ambient Sensor Circuit"](#).

10. CHECK IN-VEHICLE SENSOR

TROUBLE DIAGNOSIS

< SERVICE INFORMATION >

Press  (DEF) switch a second time. Temperature detected by in-vehicle sensor is indicated on the display (°F for U.S.A. model, °C for Canada and Mexico models).

NOTE:

If temperature shown on display greatly differs from actual temperature, check sensor circuit first, then inspect sensor.

OK or NG

- OK >> GO TO 11.
- NG >> GO TO [ATC-80, "In-vehicle Sensor Circuit"](#).

11. CHECK INTAKE SENSOR

Press  (DEF) switch a third time. Temperature detected by intake sensor is indicated on the display (°F for U.S.A. model, °C for Canada and Mexico models).

NOTE:

If temperature shown on display greatly differs from actual temperature, check sensor circuit first, then inspect sensor.

OK or NG

- OK >> GO TO 12.
- NG >> GO TO [ATC-85, "Intake Sensor Circuit"](#).

12. CHECK CAN COMMUNICATION ERROR

1. Press  (REC) switch.
2. CAN communication error between unified meter and A/C amp. and DISPLAY UNIT or DISPLAY CONTROL UNIT is detected.

OK or NG

- OK >> 1. Turn ignition switch OFF or AUTO switch ON.
- 2. Inspection End.
- NG >> Go to CAN communication.
 - Unified meter and A/C amp. - DISPLAY UNIT
 - Unified meter and A/C amp. - DISPLAY CONTROL UNIT

Display	CAN communication error
	In good order
	Display unit or Display control unit ⇨ Unified meter and A/C amp.
	Unified meter and A/C amp. ⇨ Display unit or Display control unit

RJIA1762E

13. CHECK MALFUNCTIONING SENSOR

Refer to the following chart for malfunctioning code No.

(If two or more sensors malfunction, corresponding code Nos. blink respectively twice.)

When conducting indoors, aim a light (more than 60W) at sunload sensor, otherwise Code No. 25 will indicate despite that sunload sensor is functioning properly.

NOTE:

Code 20 will be displayed if all sensors and PBR(s) are OK.

Code No.	Malfunctioning sensor (Including circuits)	Reference page
21 / -21	Ambient sensor	ATC-77
22 / -22	In-vehicle sensor	ATC-80
24 / -24	Intake sensor	ATC-85
25 / -25	Sunload sensor *1	ATC-82
26 / -26	Air mix door motor PBR (Driver)	ATC-45
27 / -27	Air mix door motor PBR (Passenger)	

*1: Conduct self-diagnosis STEP-2 under sunshine.

TROUBLE DIAGNOSIS

< SERVICE INFORMATION >

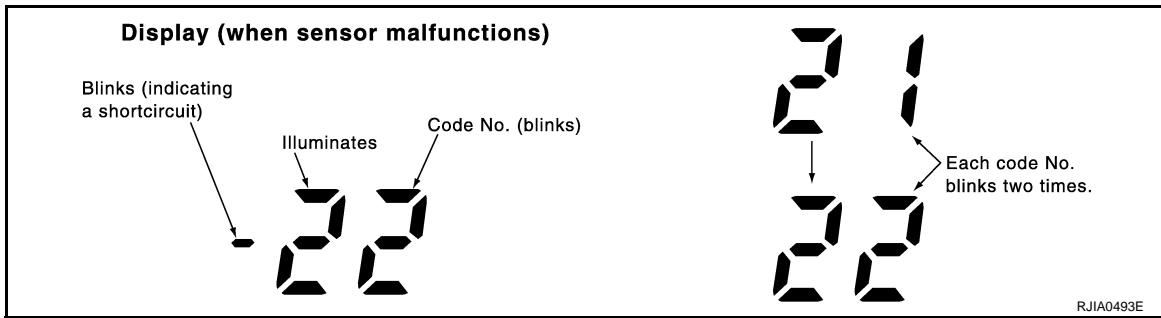

>> Inspection End.

14. CHECK MALFUNCTIONING DOOR MOTOR POSITION SWITCH

Mode and/or intake door motor PBR(s) malfunctioning.

NOTE:

Code 30 will be displayed if all doors are OK.

Code No. *1 *2	Mode or intake door position	Reference page
31	VENT	Mode door motor ATC-47
32	B/L 1	
33	B/L 2	
34	FOOT*3	
35	D/F	
36	DEF	
37	FRE	Intake door motor ATC-53
38	20% FRE	
39	REC	

(If two or more mode or intake doors are out of order, corresponding code numbers blink respectively twice.)

*1: If mode door motor harness connector is disconnected, the following display pattern will appear.

31→32→33→34→35→36→Return to 31

*2: If intake door motor harness connector is disconnected, the following display pattern will appear.

37→38→39→Return to 37

*3: FOOT position during automatic control. Refer to "AUXILIARY MECHANISM: DEFROST/FOOT POSITION SETTING TRIMMER".

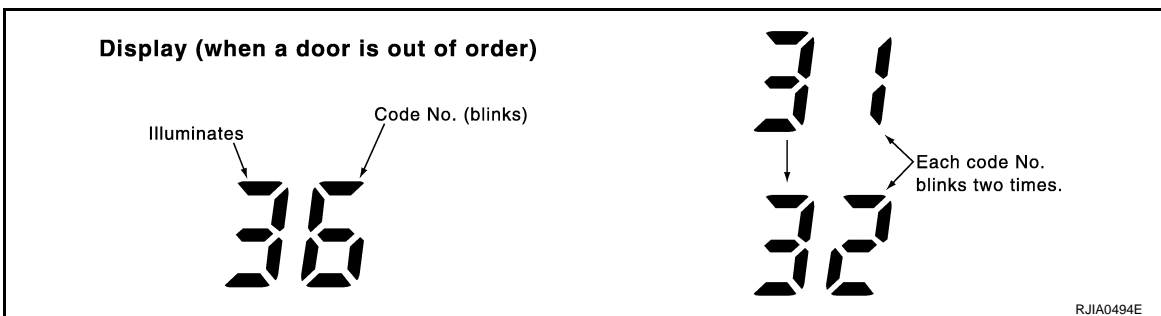

>> Inspection End.

AUXILIARY MECHANISM: TEMPERATURE SETTING TRIMMER

The trimmer compensates for differences in range of $\pm 3^{\circ}\text{C}$ ($\pm 6^{\circ}\text{F}$) between temperature setting (displayed digitally) and temperature felt by driver.

Operating procedures for this trimmer are as follows:

- Begin Self-diagnosis STEP 5 mode. Refer to "A/C System Self-diagnosis Function".
- Press top of blower control switch to set system in auxiliary mode.

TROUBLE DIAGNOSIS

< SERVICE INFORMATION >

- Display initially shows 61 in auxiliary mechanism. It takes approximately 3 seconds to display the temperature trimmer value.
- Rotate temperature control dial clockwise (driver) as desired. Temperature will change at a rate of 0.5°C (1.0°F) each time the dial is turned.

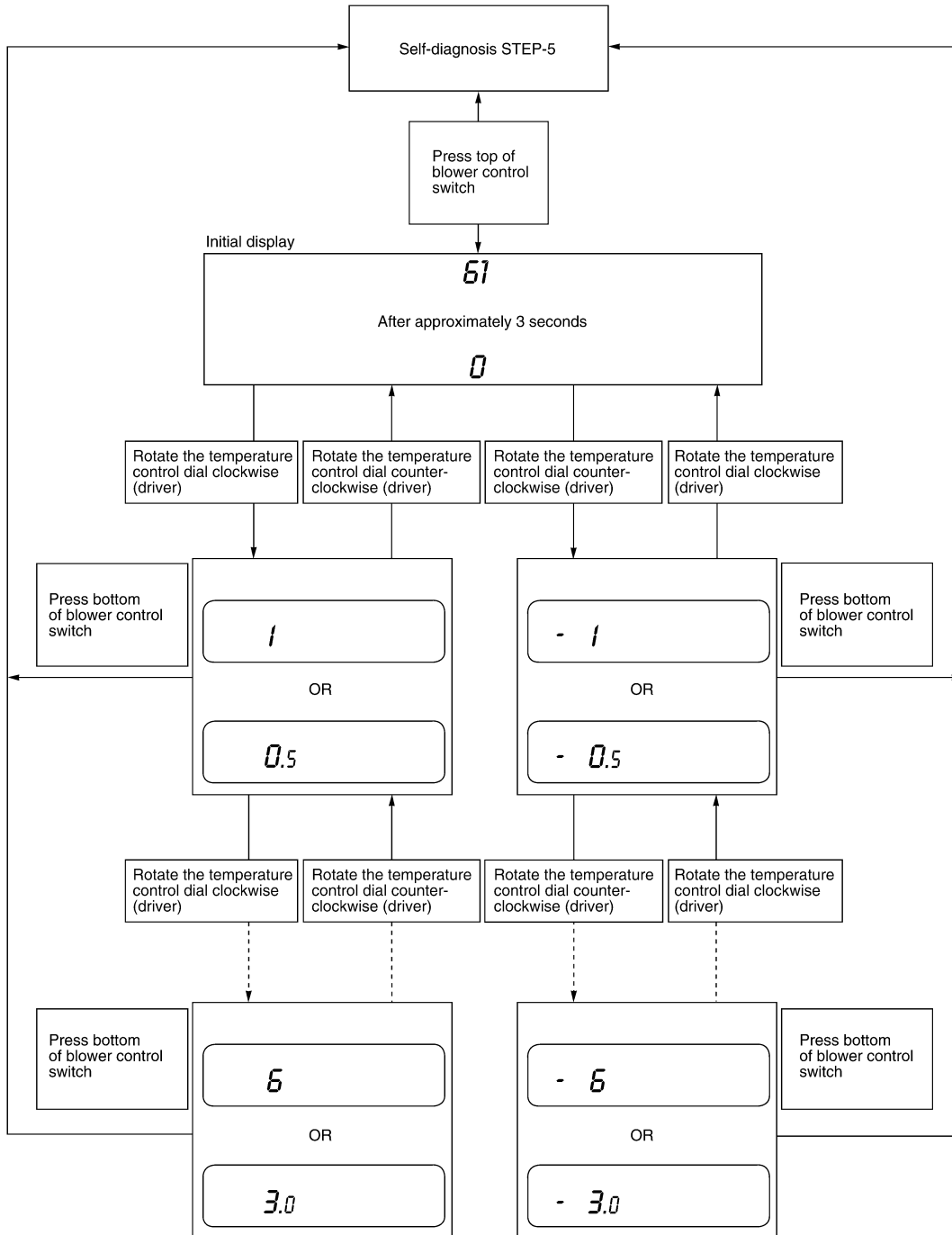

WJIA2186E

When battery cable is disconnected or if battery voltages falls below 10V, trimmer operation (setting) is canceled. Temperature set becomes that of initial condition, i.e. 0°C (0°F).

AUXILIARY MECHANISM: DEFROST/FOOT POSITION SETTING TRIMMER

Air distribution ratio in FOOT mode can be set.

TROUBLE DIAGNOSIS

< SERVICE INFORMATION >

Operating procedures for this trimmer are as follows:

- Begin Self-diagnosis STEP 5 mode. Refer to "A/C System Self-diagnosis Function".
- Press top of blower control switch to set system in auxiliary mode.
- Display initially shows 61 in auxiliary mechanism. It takes approximately 3 seconds to display the temperature trimmer value.
- Press the mode switch as desired.

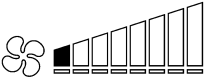
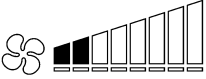
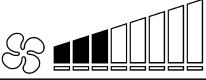
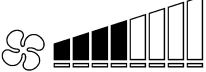
Display	Discharge air flow			
	Automatically controls the mode door		Manually controls the mode door	
	FOOT	DEF	FOOT	DEF
	75%	25%	100%	—
	75%	25%	75%	25%
	100%	—	75%	25%
	100%	—	100%	—

RJA1764E

AUXILIARY MECHANISM: INLET PORT MEMORY FUNCTION

When ignition key is turned from OFF to ON, inlet port can be set to AUTO or manual.

Operating procedures for this trimmer are as follows:

- Begin Self-diagnosis STEP 5 mode. Refer to "A/C System Self-diagnosis Function".
- Press top of blower control switch to set system in auxiliary mode.
- Display shows 61 in auxiliary mechanism. It takes approximately 3 seconds.
- Press the recirculation  (REC) switch as desired.

Switch	LED status of REC switch	Setting status	Setting changeover method
REC	ON	Manual REC status is memorized. (Initial setting)	REC SW: ON
	OFF	Manual FRE status is memorized.	REC SW: OFF

Operational Check

INFOID:000000001721305

The purpose of the operational check is to confirm that the system operates properly.

Conditions : Engine running and at usual operating temperature

CHECKING MEMORY FUNCTION

1. Set the temperature to 32°C (90°F).
2. Press the OFF switch.
3. Turn ignition switch OFF.
4. Start engine.
5. Press the AUTO switch.
6. Confirm that the set temperature remains at previous temperature.
7. Press the OFF switch.

If NG, go to trouble diagnosis procedure for [ATC-77. "Memory Function"](#).

If OK, continue with next check.

CHECKING BLOWER

1. Press top of blower control switch. Blower should operate on low speed. The fan symbol should have one blade lit.

TROUBLE DIAGNOSIS

< SERVICE INFORMATION >

2. Press top of blower control switch again, and continue checking blower speed and fan symbol until all speeds are checked. A
3. Leave blower on maximum speed.



If NG, go to trouble diagnosis procedure for [ATC-55. "Blower Motor Circuit"](#).

If OK, continue with next check. B

CHECKING DISCHARGE AIR

1. Press MODE switch four times and  (DEF) switch. C

NOTE:

Confirm that the compressor clutch is engaged (sound or visual inspection) and intake door position is at  (FRE) when the  (DEF) or  (D/F) is selected. D

2. Each position indicator should change shape in display.
3. Confirm that discharge air comes out according to the air distribution table. Refer to [ATC-22. "Discharge Air Flow"](#). E

If NG, go to trouble diagnosis procedure for [ATC-47. "Mode Door Motor Circuit"](#).

If OK, continue with next check. F

CHECKING RECIRCULATION

1. Press the OFF switch.
2. Press the AUTO switch.
3. Press recirculation  (REC) switch one time. Recirculation indicator should illuminate. G
4. Listen for intake door position change (blower sound should change slightly).

If NG, go to trouble diagnosis procedure for [ATC-53. "Intake Door Motor Circuit"](#).

If OK, continue with next check. H

CHECKING TEMPERATURE DECREASE

1. Rotate temperature control dial counterclockwise (driver) until 16°C (60°F) is displayed. I
2. Check for cold air at discharge air outlets.

If NG, go to trouble diagnosis procedure for [ATC-65. "Insufficient Cooling"](#).

If OK, continue with next check. ATC

CHECKING TEMPERATURE INCREASE

1. Rotate temperature control dial clockwise (driver) until 32°C (90°F) is displayed. K
2. Check for hot air at discharge air outlets.

If NG, go to trouble diagnosis procedure for [ATC-73. "Insufficient Heating"](#).

If OK, continue with next check. L

CHECKING TEMPERATURE DECREASE

1. Press the DUAL switch (indicator ON).
2. Rotate temperature control dial counterclockwise (passenger) until 16°C (60°F) is displayed. M
3. Check for cold air at passenger discharge air outlets.

If NG, go to trouble diagnosis procedure for [ATC-65. "Insufficient Cooling"](#).

If OK, continue with next check. N

CHECKING TEMPERATURE INCREASE

1. Rotate temperature control dial clockwise (passenger) until 32°C (90°F) is displayed. O
2. Check for hot air at passenger discharge air outlets.

If NG, go to trouble diagnosis procedure for [ATC-73. "Insufficient Heating"](#).

If OK, continue with next check. P

CHECK A/C SWITCH

1. Press the OFF switch.
2. Press the top of the fan switch. the fan should operate.
3. Press A/C switch.
4. A/C switch indicator will turn ON.
 - Confirm that the compressor clutch engages (sound or visual inspection).

TROUBLE DIAGNOSIS

< SERVICE INFORMATION >

If NG, go to trouble diagnosis procedure for [ATC-61, "Magnet Clutch Circuit"](#).

If OK, continue with next check.

CHECK NAVI DISPLAY OR A/C DISPLAY

1. Turn ignition switch ON.
2. Press each switch on the front air control and monitor the HVAC display.
 - Confirm that the HVAC display operates correctly for each switch pressed.

If NG, go to trouble diagnosis procedure for NAVI, refer to [AV-133, "On Board Self-Diagnosis Function"](#). For A/C display refer to [ATC-89, "A/C Display \(without NAVI\)"](#).

If OK, continue with next check.

CHECKING AUTO MODE

1. Press the OFF switch.
2. Press AUTO switch.
3. Display should indicate AUTO.
 - Confirm that the compressor clutch engages (sound or visual inspection). (Discharge air and blower speed will depend on ambient, in-vehicle, and set temperatures.)

If NG, go to trouble diagnosis procedure for [ATC-42, "Power Supply and Ground Circuit for Front Air Control and Unified Meter and A/C Amp"](#), then if necessary, trouble diagnosis procedure for [ATC-61, "Magnet Clutch Circuit"](#).

If all operational checks are OK (symptom cannot be duplicated), go to malfunction Simulation Tests in [ATC-25, "How to Perform Trouble Diagnosis for Quick and Accurate Repair"](#) and perform tests as outlined to simulate driving conditions environment. If symptom appears, refer to, [ATC-25, "How to Perform Trouble Diagnosis for Quick and Accurate Repair"](#) and perform applicable trouble diagnosis procedures.

Power Supply and Ground Circuit for Front Air Control and Unified Meter and A/C Amp

INFOID:000000001721306

SYMPTOM: A/C system does not come on.

INSPECTION FLOW

1. CONFIRM SYMPTOM BY PERFORMING OPERATIONAL CHECK - AUTO MODE

1. Press AUTO switch.
2. Display should indicate AUTO. Confirm that the compressor clutch engages (sound or visual inspection). (Discharge air and fan speed will depend on ambient, in-vehicle and set temperatures.)

Can a symptom be duplicated?

- YES >> GO TO 3.
NO >> GO TO 2.

2. PERFORM COMPLETE OPERATIONAL CHECK

Perform a complete operational check and check for any symptoms. Refer to [ATC-40, "Operational Check"](#).

Can a symptom be duplicated

- YES >> Refer to [ATC-25, "How to Perform Trouble Diagnosis for Quick and Accurate Repair"](#).
NO >> System OK.

3. CHECK FOR SERVICE BULLETINS

Check for any service bulletins.

OK >> Check power and ground circuits. Refer to "DIAGNOSTIC PROCEDURE FOR A/C SYSTEM".

COMPONENT DESCRIPTION

Unified meter and A/C amp. (Automatic Amplifier)

TROUBLE DIAGNOSIS

< SERVICE INFORMATION >

The unified meter and A/C amp. has a built-in microcomputer which processes information sent from various sensors needed for air conditioner operation. The air mix door motors, mode door motor, intake door motor, blower motor and compressor are then controlled. The unified meter and A/C amp. is unitized with control mechanisms. When the various switches and temperature dials are operated from the front air control, data is input to the unified meter and A/C amp. from the front air control using the multiplex communication. Self-diagnostic functions are also built into unified meter and A/C amp. to provide quick check of malfunctions in the auto air conditioner system.

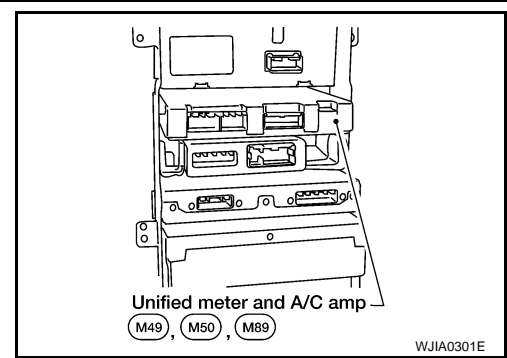

Potential Temperature Control (PTC)

The PTC is built into the front air control. It can be set at an interval of 0.5°C (1.0°F) in the 16°C (60°F) to 32°C (90°F) temperature range by rotating the temperature dial. The set temperature is displayed.

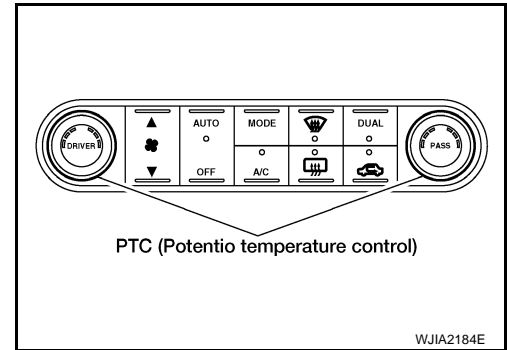

DIAGNOSTIC PROCEDURE FOR A/C SYSTEM

SYMPTOM: A/C system does not come on.

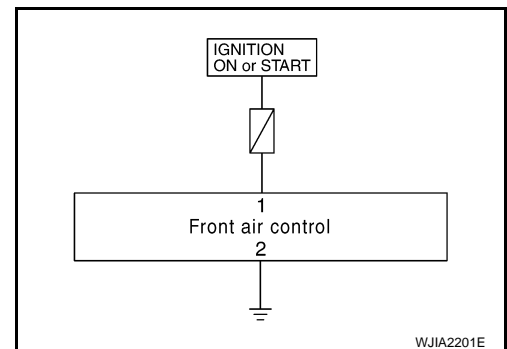
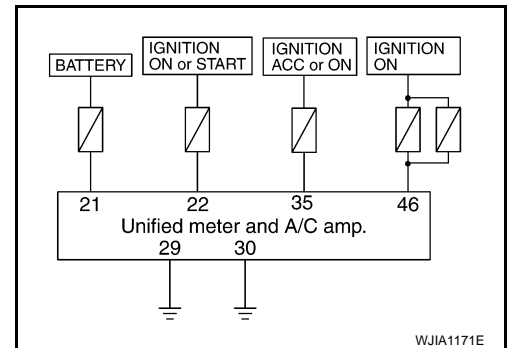

1. CHECK FRONT AIR CONTROL

Perform front air control self-diagnosis. Refer to [ATC-90. "Front Air Control Self - Diagnosis"](#).

OK or NG

- OK >> GO TO 4.
- NG >> GO TO 2.

2. CHECK POWER SUPPLY CIRCUIT FOR FRONT AIR CONTROL.

1. Turn ignition switch OFF.

A
B
C
D
E
F
G
H
I
J
K
L
M
N
O
P

ATC

TROUBLE DIAGNOSIS

< SERVICE INFORMATION >

- Disconnect front air control connector.
- Turn ignition switch ON.
- Check voltage between unified meter and A/C amp. harness connector M49 terminal 1 and ground.

Terminals		Ignition switch position			
(+)		(-)	OFF	ACC	ON
Front air control	Terminal No.				
M201	1	Ground	Approx. 0V	Approx. 0V	Battery voltage

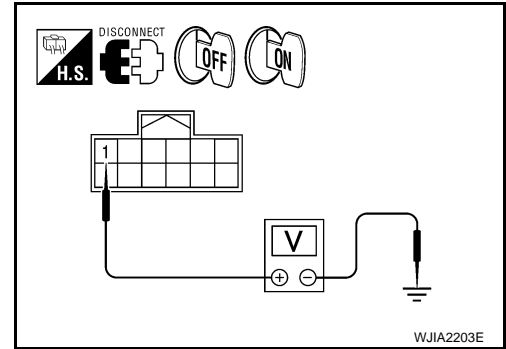

OK or NG

- OK >> GO TO 3.
 NG >> Check harness for open circuit. Repair harness as necessary.

3. CHECK GROUND CIRCUIT FOR FRONT AIR CONTROL

- Turn ignition switch OFF.
- Check continuity between front air control harness connector M201 terminal 2 and ground.

2 – Ground : Continuity should exist.

OK or NG

- OK >> Replace front air control. Refer to [IP-13, "Center Stack Assembly"](#).
 NG >> Repair harness or connector.

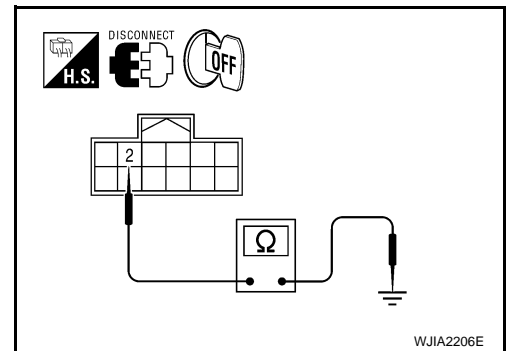

4. CHECK POWER SUPPLY CIRCUIT FOR UNIFIED METER AND A/C AMP.

- Turn ignition switch OFF.
- Disconnect unified meter and A/C amp. connector.
- Check voltage between unified meter and A/C amp. harness connector M50 terminals 21, 22 and 35, unified meter and A/C amp. harness connector M89 terminal 46 and ground.

Terminals		Ignition switch position			
(+)		(-)	OFF	ACC	ON
Unified meter and A/C amp. connector	Terminal No.				
M50	21	Ground	Battery voltage	Battery voltage	Battery voltage
M50	22		Approx. 0V	Approx. 0V	Battery voltage
M50	35		Approx. 0V	Battery voltage	Battery voltage
M89	46		Approx. 0V	Approx. 0V	Battery voltage

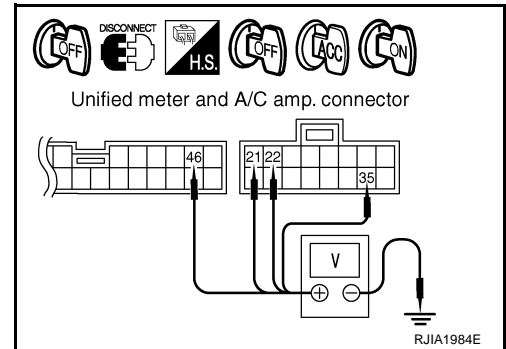

OK or NG

- OK >> GO TO 5.
 NG >> Check fuses [Nos. 6, 12 and 19 (10A) and 10 (15A), located in the fuse block (J/B)]. Refer to [PG-73](#).
- If fuses are OK, check harness for open circuit. Repair or replace as necessary.
 - If fuses are NG, replace fuse and check harness for short circuit. Repair or replace as necessary.

TROUBLE DIAGNOSIS

< SERVICE INFORMATION >

5. CHECK GROUND CIRCUIT FOR UNIFIED METER AND A/C AMP.

1. Turn ignition switch OFF.
2. Check continuity between unified meter and A/C amp. harness connector M50 terminals 29, 30 and ground.

29, 30 – Ground : Continuity should exist.

OK or NG

- OK >> Check multiplex communication circuit. Refer to [ATC-87, "Multiplex Communication Circuit"](#).
- NG >> Repair harness or connector.

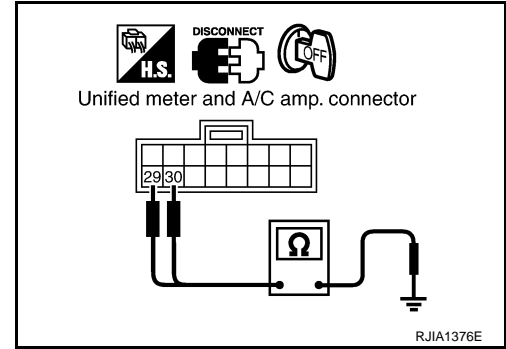

LAN System Circuit

INFOID:000000001721307

SYMPTOM: Mode door motor, intake door motor and/or air mix door motor(s) does not operate normally.

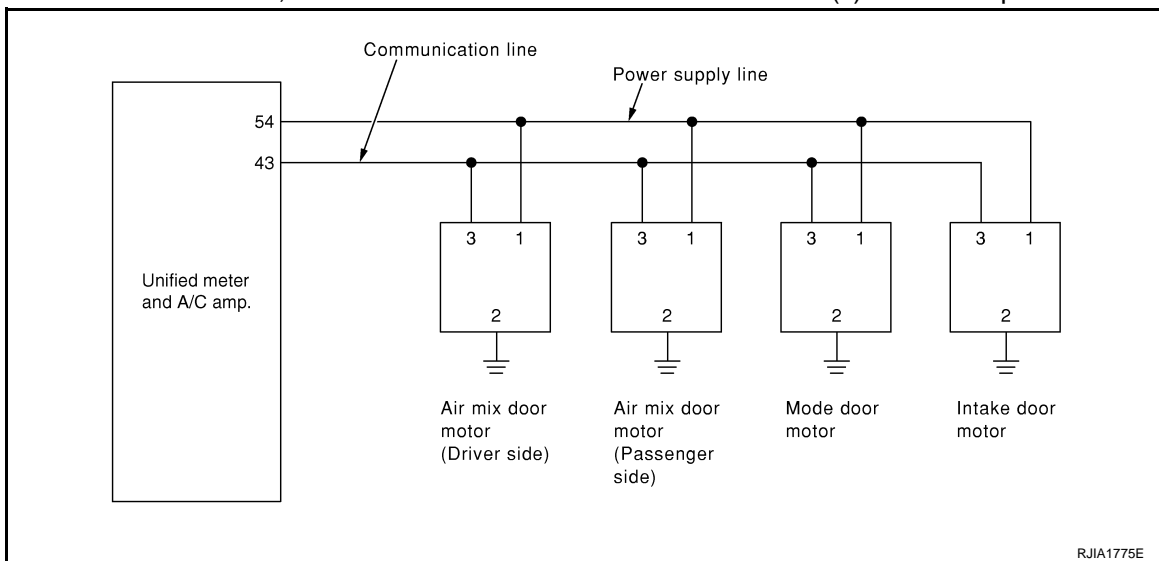

DIAGNOSTIC PROCEDURE FOR LAN CIRCUIT

1. CHECK POWER SUPPLY FOR UNIFIED METER AND A/C AMP. SIDE

1. Turn ignition switch ON.
2. Check voltage between unified meter and A/C amp. harness connector M89 terminal 54 and ground.

54 – Ground : Battery voltage

OK or NG

- OK >> GO TO 2.
- NG >> Replace unified meter and A/C amp. Refer to [ATC-92](#).

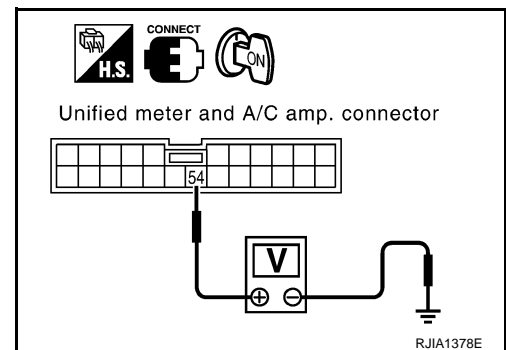

2. CHECK SIGNAL FOR UNIFIED METER AND A/C AMP. SIDE

TROUBLE DIAGNOSIS

< SERVICE INFORMATION >

Confirm A/C LAN signal between unified meter and A/C amp. harness connector M89 terminal 43 and ground using an oscilloscope.

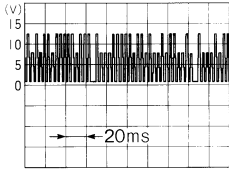
Terminals		(-)	Voltage
(+) Terminal No.			
Unified meter and A/C amp. connector			
M89	43	Ground	

HAK0652D

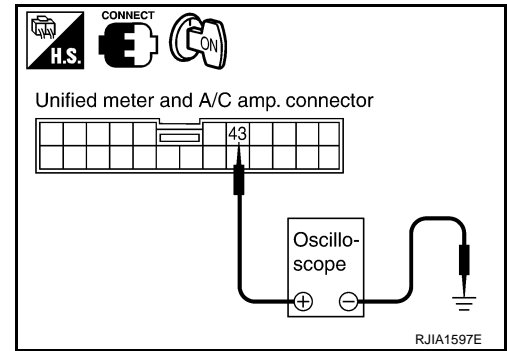

OK or NG

OK >> GO TO 3.

NG >> Replace unified meter and A/C amp. Refer to [ATC-92](#).

3. CHECK POWER SUPPLY FOR INOPERATIVE DOOR MOTOR

Check voltage between inoperative door motor harness connector terminal 1 and ground.

1 – Ground : Battery voltage

OK or NG

OK >> GO TO 4.

NG >> Repair harness or connector.

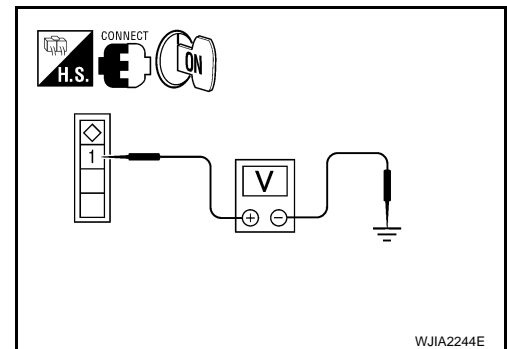

4. CHECK SIGNAL SIDE FOR INOPERATIVE DOOR MOTOR

Confirm A/C LAN signal between inoperative door motor harness connector terminal 3 and ground using an oscilloscope.

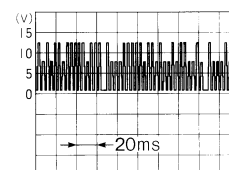
Door motor	Terminals		(-)	Voltage
	(+) Terminal No.			
	Con-connector	Terminal No.		
Mode	M40	3	Ground	
Air mix (Driver)	M39	3		
Air mix (Passenger)	M87	3		
Intake	M58	3		

HAK0652D

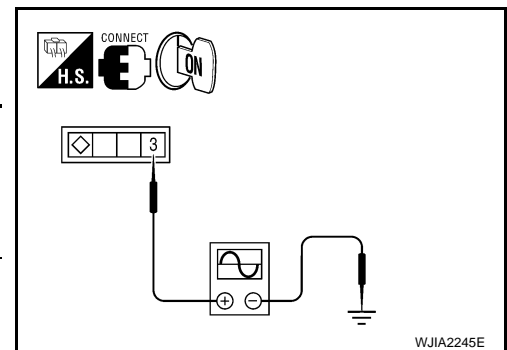

OK or NG

OK >> GO TO 5.

NG >> Repair harness or connector.

5. CHECK INOPERATIVE DOOR MOTOR GROUND CIRCUIT

TROUBLE DIAGNOSIS

< SERVICE INFORMATION >

1. Turn ignition switch OFF.
2. Disconnect inoperative door motor connector.
3. Check continuity between inoperative door motor harness connector terminal 2 and ground.

2 – Ground : Continuity should exist.

OK or NG

- OK >> • Replace mode door motor if inoperative. Refer to [ATC-103](#).
• Replace intake door motor if inoperative. Refer to [ATC-103](#).
• Replace driver side air mix door motor if inoperative. Refer to [ATC-104](#), "[Removal and Installation](#)".
• Replace passenger side air mix door motor if inoperative. Refer to [ATC-104](#), "[Removal and Installation](#)".
- NG >> Repair harness or connector.

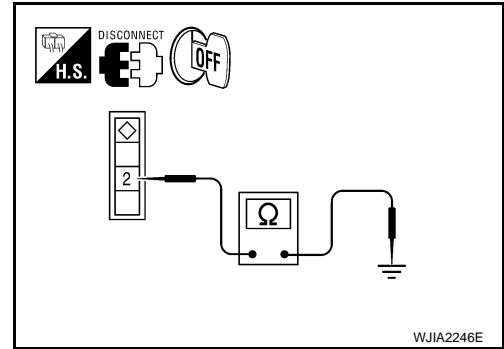

Mode Door Motor Circuit

INFOID:000000001721308

SYMPTOM:

- Air outlet does not change.
- Mode door motor does not operate normally.

INSPECTION FLOW

1. CONFIRM SYMPTOM BY PERFORMING OPERATIONAL CHECK - DISCHARGE AIR

1. Start engine.
2. Press mode switch four times and then press the (defrost) switch. Each position indicator should change shape (on display).

NOTE:

Confirm that the compressor clutch is engaged (sound or visual inspection) and intake door position is at (FRE) when (DEF) or (D/F) is selected.

3. Confirm that discharge air comes out according to the air distribution table. Refer to [ATC-22](#), "[Discharge Air Flow](#)".

Can a symptom be duplicated?

- YES >> GO TO 3.
NO >> GO TO 2.

2. PERFORM COMPLETE OPERATIONAL CHECK

Perform a complete operational check and check for any symptoms. Refer to [ATC-40](#), "[Operational Check](#)".

Can a symptom be duplicated?

- YES >> Refer to [ATC-25](#), "[How to Perform Trouble Diagnosis for Quick and Accurate Repair](#)".
NO >> System OK.

3. CHECK FOR SERVICE BULLETINS

Check for any service bulletins.

>> GO TO 4.

4. PERFORM FRONT AIR CONTROL SELF-DIAGNOSIS

Perform front air control self-diagnosis. Refer to [ATC-90](#), "[Front Air Control Self - Diagnosis](#)".

OK or NG

- OK >> GO TO 5.
NG >> Perform power and ground circuit for front air control. Refer to [ATC-42](#), "[Power Supply and Ground Circuit for Front Air Control and Unified Meter and A/C Amp](#)".

5. PERFORM SELF-DIAGNOSIS STEP - 2

Perform self-diagnosis STEP - 2. Refer to [ATC-34](#), "[A/C System Self-Diagnosis Function](#)".

TROUBLE DIAGNOSIS

< SERVICE INFORMATION >

OK or NG

- OK >> GO TO 6.
NG >> Check appropriate malfunctioning sensor circuit.

6.PERFORM SELF-DIAGNOSIS STEP - 3

Perform self-diagnosis STEP - 3. Refer to [ATC-34, "A/C System Self-Diagnosis Function"](#).

OK or NG

- OK >> GO TO 7.
NG >> Perform diagnostic procedure for LAN system circuit. Refer to [ATC-45, "LAN System Circuit"](#).

7.PERFORM SELF-DIAGNOSIS STEP - 4

Perform self-diagnosis STEP - 4 to check mode door control. Refer to [ATC-34, "A/C System Self-Diagnosis Function"](#).

OK or NG

- OK >> GO TO 8.
NG >> Check and repair mode door motor linkage. Refer to [ATC-103](#).

8.CHECK AMBIENT SENSOR CIRCUIT (CAUSE CANNOT BE CONFIRMED BY SELF-DIAGNOSIS)

Perform diagnostic procedure for the ambient sensor circuit. Refer to [ATC-77, "Ambient Sensor Circuit"](#).

OK or NG

- OK >> GO TO 9.
NG >> Repair as necessary.

9.CHECK IN-VEHICLE SENSOR CIRCUIT

Perform diagnostic procedure for the in-vehicle sensor circuit. Refer to [ATC-80, "In-vehicle Sensor Circuit"](#).

OK or NG

- OK >> GO TO 10.
NG >> Repair as necessary.

10.CHECK SUNLOAD SENSOR CIRCUIT

Perform diagnostic procedure for the sunload sensor circuit. Refer to [ATC-82, "Sunload Sensor Circuit"](#).

OK or NG

- OK >> GO TO 11.
NG >> Repair as necessary.

11.CHECK INTAKE SENSOR CIRCUIT

Perform diagnostic procedure for the ambient sensor circuit. Refer to [ATC-85, "Intake Sensor Circuit"](#).

OK or NG

- OK >> GO TO 12.
NG >> Repair as necessary.

12.CHECK AIR MIX DOOR MOTOR PBR CIRCUIT

Perform diagnostic procedure for the air mix door motor circuit. Refer to [ATC-50, "Air Mix Door Motor Circuit"](#).

OK or NG

- OK >> If the symptom still exists, perform a complete operational check. Refer to [ATC-40, "Operational Check"](#). If no other symptom exists replace unified meter and A/C amp. Refer to [ATC-92](#).
NG >> Repair as necessary.

SYSTEM DESCRIPTION

Component Parts

Mode door control system components are:

- Unified meter and A/C amp.
- Mode door motor (LCU)
- A/C LAN system (PBR built-into mode door motor, intake door motor and air mix door motor)
- In-vehicle sensor
- Ambient sensor

TROUBLE DIAGNOSIS

< SERVICE INFORMATION >

- Sunload sensor
- Intake sensor

System Operation

The unified meter and A/C amp. receives data from each of the sensors. The unified meter and A/C amp. sends air mix door, mode door and intake door opening angle data to the air mix door motor LCU, mode door motor LCU and intake door motor LCU.

The air mix door motor, mode door motor and intake door motor read their respective signals according to the address signal. Opening angle indication signals received from the unified meter and A/C amp. and each of the motor position sensors are compared by the LCUs in each motor with the existing decision and opening angles. Subsequently, HOT/COLD or DEFROST/VENT or FRESH/RECIRCULATION operation is selected. The new selection data is returned to the unified meter and A/C amp.

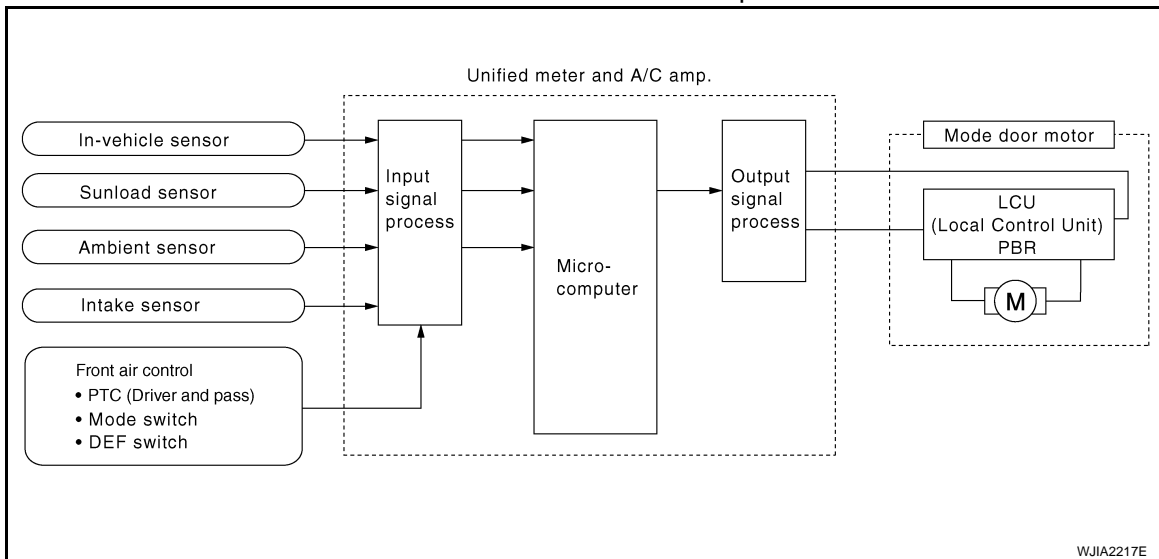

Mode Door Control Specification

COMPONENT DESCRIPTION

Mode Door Motor

The mode door motor is attached to the heater and cooling unit assembly. It rotates so that air is discharged from the outlet set by the unified meter and A/C amp. Motor rotation is conveyed to a link which activates the mode door.

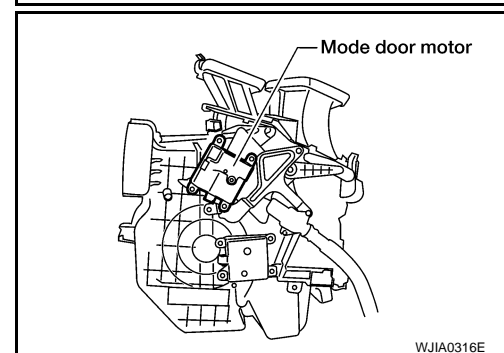
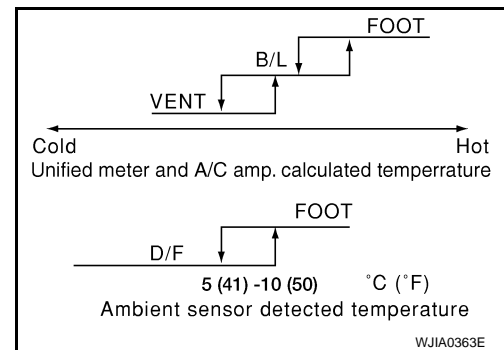

DIAGNOSTIC PROCEDURE FOR MODE DOOR MOTOR

SYMPTOM: Mode door motor does not operate normally.

Perform diagnostic procedure for LAN circuit. Refer to [ATC-45. "LAN System Circuit"](#).

TROUBLE DIAGNOSIS

< SERVICE INFORMATION >

Air Mix Door Motor Circuit

INFOID:000000001721309

SYMPTOM:

- Discharge air temperature does not change.
- Air mix door motor does not operate.

INSPECTION FLOW

1. CONFIRM SYMPTOM BY PERFORMING OPERATIONAL CHECK - TEMPERATURE INCREASE

1. Turn the temperature control dial (driver) clockwise until 32°C (90°F) is displayed.
2. Check for hot air at discharge air outlets.

>> GO TO 2.

2. CONFIRM SYMPTOM BY PERFORMING OPERATIONAL CHECK - TEMPERATURE DECREASE

1. Turn the temperature control dial (driver) counterclockwise until 16°C (60°F) is displayed.
2. Check for cold air at discharge air outlets.

Can a symptom be duplicated?

- YES >> GO TO 4.
NO >> GO TO 3.

3. PERFORM COMPLETE OPERATIONAL CHECK

Perform a complete operational check and check for any symptoms. Refer to [ATC-40, "Operational Check"](#).

Can a symptom be duplicated?

- YES >> Refer to [ATC-25, "How to Perform Trouble Diagnosis for Quick and Accurate Repair"](#).
NO >> System OK.

4. CHECK FOR SERVICE BULLETINS

Check for any service bulletins.

>> GO TO 5.

5. PERFORM FRONT AIR CONTROL SELF-DIAGNOSIS

Perform front air control self-diagnosis. Refer to [ATC-90, "Front Air Control Self - Diagnosis"](#).

OK or NG

- OK >> GO TO 6.
NG >> Perform power and ground circuit for front air control. Refer to [ATC-42, "Power Supply and Ground Circuit for Front Air Control and Unified Meter and A/C Amp"](#).

6. PERFORM SELF-DIAGNOSIS STEP - 2

Perform self-diagnosis STEP - 2. Refer to [ATC-34, "A/C System Self-Diagnosis Function"](#).

OK or NG

- OK >> GO TO 7.
OK >> Perform appropriate malfunctioning sensor circuit.

7. PERFORM SELF-DIAGNOSIS STEP - 4

Perform self-diagnosis STEP - 4. Refer to [ATC-34, "A/C System Self-Diagnosis Function"](#).

OK and NG

- OK >> GO TO 8.
NG >> Check LAN system circuit. Refer to [ATC-45, "LAN System Circuit"](#).

8. CHECK AMBIENT SENSOR CIRCUIT (CAUSE CANNOT BE CONFIRMED BY SELF-DIAGNOSIS)

Perform diagnostic procedure for the ambient sensor circuit. Refer to [ATC-77, "Ambient Sensor Circuit"](#).

OK or NG

- OK >> GO TO 9.
NG >> Repair as necessary.

TROUBLE DIAGNOSIS

< SERVICE INFORMATION >

9. CHECK IN-VEHICLE SENSOR CIRCUIT

Perform diagnostic procedure for the in-vehicle sensor circuit. Refer to [ATC-80, "In-vehicle Sensor Circuit"](#).

OK or NG

OK >> GO TO 10.

NG >> Repair as necessary.

10. CHECK SUNLOAD SENSOR CIRCUIT

Perform diagnostic procedure for the sunload sensor circuit. Refer to [ATC-82, "Sunload Sensor Circuit"](#).

OK or NG

OK >> GO TO 11.

NG >> Repair as necessary.

11. CHECK INTAKE SENSOR CIRCUIT

Perform diagnostic procedure for the intake sensor circuit. Refer to [ATC-85, "Intake Sensor Circuit"](#).

OK or NG

OK >> GO TO 12.

NG >> Repair as necessary.

12. CHECK AIR MIX DOOR MOTOR PBR CIRCUIT

Perform diagnostic procedure for the air mix door motor circuit. Refer to "Air Mix Door Motor Circuit".

OK or NG

OK >> If the symptom still exists, perform a complete operational check. Refer to [ATC-40, "Operational Check"](#) and check for other symptoms. Refer to [ATC-25, "How to Perform Trouble Diagnosis for Quick and Accurate Repair"](#). If no other symptom exists, replace unified meter and A/C amp. Refer to [ATC-92](#).

NG >> Repair as necessary.

SYSTEM DESCRIPTION

Component Parts

Air mix door control system components are:

- Unified meter and A/C amp.
- Air mix door motor (LCU)
- A/C LAN system (PBR built-into mode door motor, intake door motor and air mix door motor)
- In-vehicle sensor
- Ambient sensor
- Sunload sensor
- Intake sensor

System Operation

The unified meter and A/C amp. receives data from each of the sensors. The unified meter and A/C amp. sends air mix door, mode door and intake door motor opening angle data to the air mix door motor LCU, mode door motor LCU and intake door motor LCU.

The air mix door motor, mode door motor and intake door motor read their respective signals according to the address signal. Opening angle indication signals received from the unified meter and A/C amp. and each of the motor position sensors are compared by the LCUs in each motor with the existing decision and opening

A
B
C
D
E
F
G
H
I
K
L
M
N
O
P

ATC

TROUBLE DIAGNOSIS

< SERVICE INFORMATION >

angles. Subsequently, HOT/COLD or DEFROST/VENT or FRESH/RECIRCULATION operation is selected. The new selection data is returned to the unified meter and A/C amp.

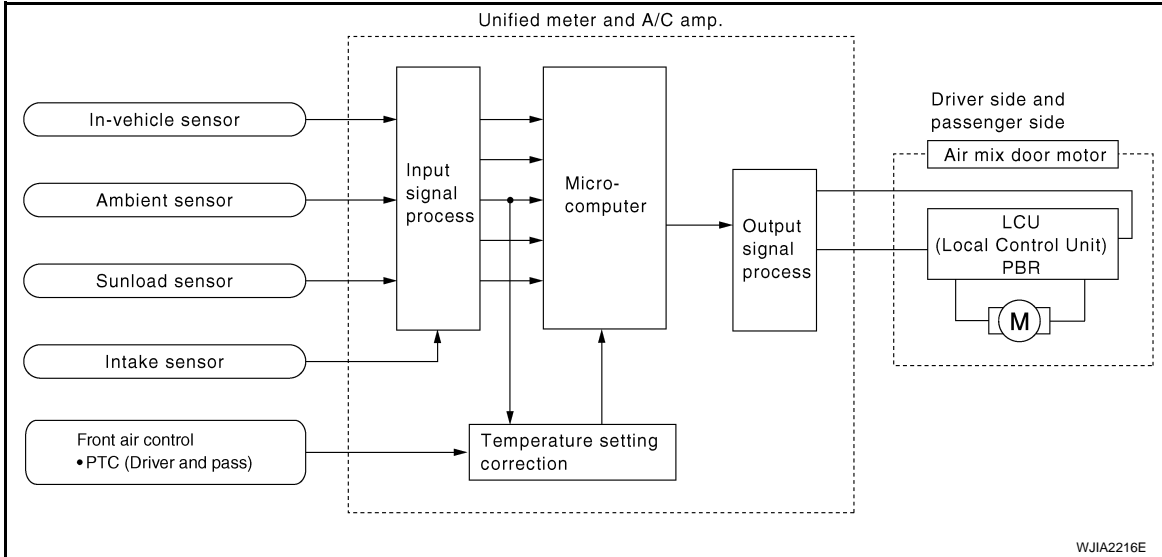

Air Mix Door Control Specification COMPONENT DESCRIPTION

Air Mix Door Motor

The air mix door motor is attached to the heater and cooling unit assembly. It rotates so that the air mix door is opened or closed to a position set by the unified meter and A/C amp. Motor rotation is then conveyed through a shaft and the air mix door position is then fed back to the unified meter and A/C amp. by PBR built-in air mix door motor.

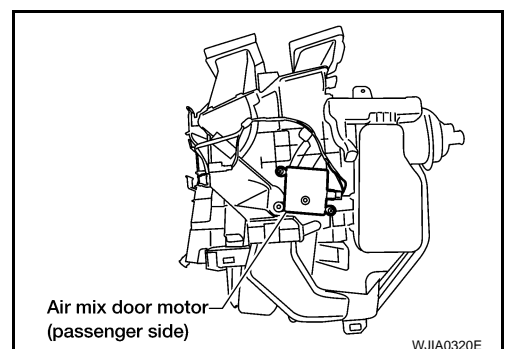
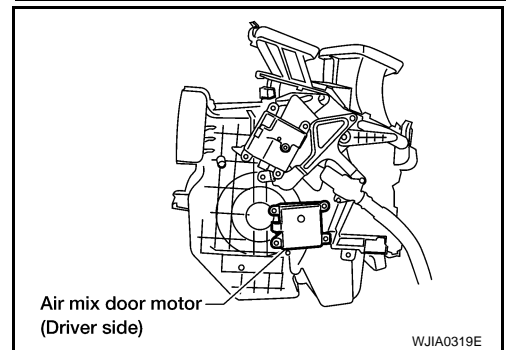
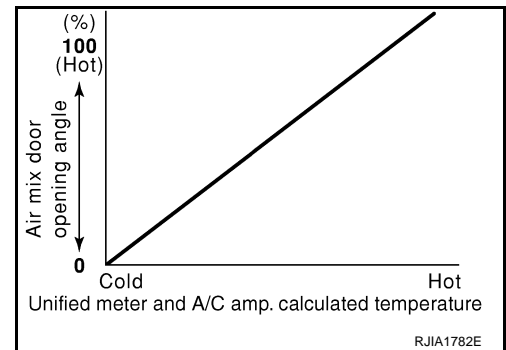

DIAGNOSTIC PROCEDURE FOR AIR MIX DOOR MOTOR

Perform diagnostic procedure for LAN circuit. Refer to [ATC-45. "LAN System Circuit"](#).

TROUBLE DIAGNOSIS

< SERVICE INFORMATION >

Air Mix Door Motor PBR Circuit

INFOID:000000001721310

SYMPTOM:

- Discharge air temperature does not change.
- PBR circuit is open or shorted.

DIAGNOSTIC PROCEDURE FOR AIR MIX DOOR MOTOR PBR CIRCUIT

Perform diagnostic procedure for LAN circuit. Refer to [ATC-45, "LAN System Circuit"](#).

Intake Door Motor Circuit





INFOID:000000001721311

SYMPTOM:

- Intake door does not change.
- Intake door motor does not operate normally.

INSPECTION FLOW

1. CONFIRM SYMPTOM BY PERFORMING OPERATIONAL CHECK - REC ()

1. Press the vent mode ().
2. Press REC () switch. The REC () indicator should illuminate.
3. Press REC () switch again. The REC () indicator should go out.
4. Listen for intake door position change (blower sound should change slightly).

Can a symptom be duplicated?

- YES >> GO TO 3.
- NO >> GO TO 2.

2. PERFORM COMPLETE OPERATIONAL CHECK

Perform a complete operational check and check for any symptoms. Refer to [ATC-40, "Operational Check"](#).

Can a symptom be duplicated?

- YES >> Refer to [ATC-25, "How to Perform Trouble Diagnosis for Quick and Accurate Repair"](#).
- NO >> System OK.

3. CHECK FOR SERVICE BULLETINS

Check for any service bulletins.

>> GO TO 4.

4. PERFORM FRONT AIR CONTROL SELF-DIAGNOSIS

Perform front air control self-diagnosis. Refer to [ATC-90, "Front Air Control Self - Diagnosis"](#).

OK or NG

- OK >> GO TO 5.
- NG >> Perform power and ground circuit for front air control. Refer to [ATC-42, "Power Supply and Ground Circuit for Front Air Control and Unified Meter and A/C Amp"](#).

5. PERFORM SELF-DIAGNOSIS STEP - 2

Perform self-diagnosis STEP - 2. Refer to [ATC-34, "A/C System Self-Diagnosis Function"](#).

OK or NG

- OK >> GO TO 6.
- NG >> Perform appropriate malfunctioning sensor circuit.

6. PERFORM SELF-DIAGNOSIS STEP - 4

Perform self-diagnosis STEP - 4. Refer to [ATC-34, "A/C System Self-Diagnosis Function"](#).

OK and NG

- OK >> GO TO 7.
- NG >> GO TO 12.

7. CHECK AMBIENT SENSOR CIRCUIT (CAUSE CANNOT BE CONFIRMED BY SELF-DIAGNOSIS)

Perform diagnostic procedure for the ambient sensor circuit. Refer to [ATC-77, "Ambient Sensor Circuit"](#).

A
B
C
D
E
F
G
H
I
K
L
M
N
O
P

ATC

TROUBLE DIAGNOSIS

< SERVICE INFORMATION >

OK or NG

- OK >> GO TO 8.
NG >> Repair as necessary.

8.CHECK IN-VEHICLE SENSOR CIRCUIT

Perform diagnostic procedure for the in-vehicle sensor circuit. Refer to [ATC-80, "In-vehicle Sensor Circuit"](#).

OK or NG

- OK >> GO TO 9.
NG >> Repair as necessary.

9.CHECK SUNLOAD SENSOR CIRCUIT

Perform diagnostic procedure for the sunload sensor circuit. Refer to [ATC-82, "Sunload Sensor Circuit"](#).

OK or NG

- OK >> GO TO 10.
NG >> Repair as necessary.

10.CHECK INTAKE SENSOR CIRCUIT

Perform diagnostic procedure for the intake sensor circuit. Refer to [ATC-85, "Intake Sensor Circuit"](#).

OK or NG

- OK >> GO TO 11.
NG >> Repair as necessary.

11.CHECK AIR MIX DOOR MOTOR PBR CIRCUIT

Perform diagnostic procedure for the air mix door motor circuit. Refer to [ATC-50, "Air Mix Door Motor Circuit"](#).

OK or NG

- OK >> If the symptom still exists, perform a complete operational check. Refer to [ATC-40, "Operational Check"](#) and check for other symptoms. Refer to [ATC-25, "How to Perform Trouble Diagnosis for Quick and Accurate Repair"](#). If no other symptoms exists replace unified meter and A/C amp. Refer to [ATC-92](#).
- NG >> Repair as necessary.

12.CHECK INTAKE DOOR CONTROL LINKAGE

Check intake door control linkage. Refer to [ATC-99](#).

OK or NG

- OK >> Check LAN system circuit. Refer to [ATC-45, "LAN System Circuit"](#).
- NG >> Repair or adjust control linkage.

SYSTEM DESCRIPTION

Component Parts

Intake door control system components are:

- Unified meter and A/C amp.
- Intake door motor
- A/C LAN system (PBR built-in mode door motor, intake door motor and air mix door motor)
- In-vehicle sensor
- Ambient sensor
- Sunload sensor
- Intake sensor
- Front air control

System Operation

TROUBLE DIAGNOSIS

< SERVICE INFORMATION >

The intake door control determines intake door position based on the ambient temperature, the intake air temperature and the in-vehicle temperature. When the DEFROST or OFF switches are pushed or A/C switch is OFF, the unified meter and A/C amp. sets the intake door at the FRESH position.

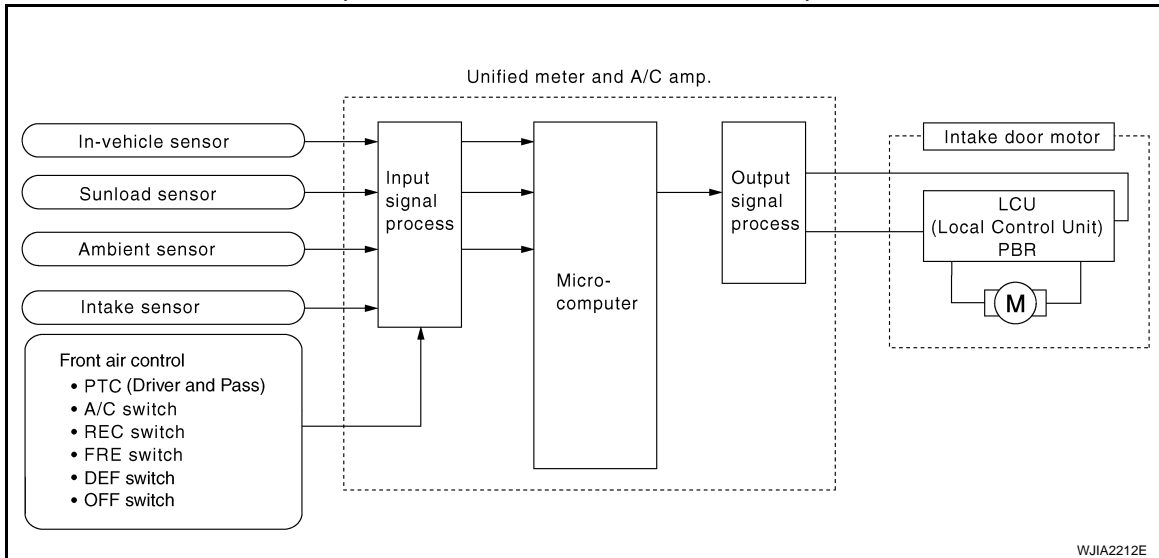

Intake Door Control Specification

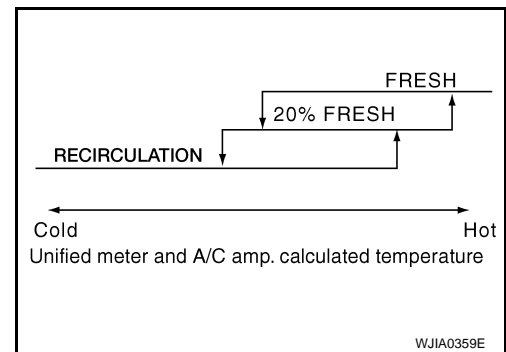

COMPONENT DESCRIPTION

Intake door motor

The intake door motor is attached to the intake unit. It rotates so that air is drawn from inlets set by the unified meter and A/C amp. Motor rotation is conveyed to a lever which activates the intake door.

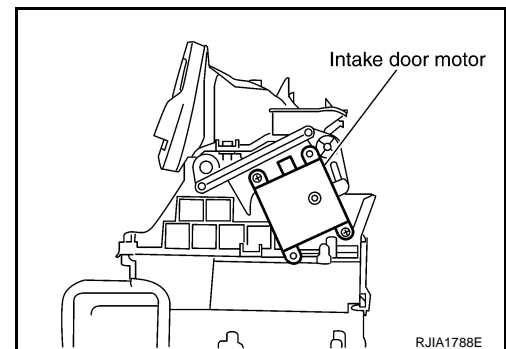

DIAGNOSTIC PROCEDURE FOR INTAKE DOOR MOTOR

SYMPTOM: Intake door motor does not operate normally.

Perform diagnostic procedure for LAN system circuit. Refer to [ATC-45. "LAN System Circuit"](#).

Blower Motor Circuit

INFOID:000000001721312

SYMPTOM:

- Blower motor operation is malfunctioning.

INSPECTION FLOW

1. CONFIRM SYMPTOM BY PERFORMING OPERATIONAL CHECK - FRONT BLOWER

TROUBLE DIAGNOSIS

< SERVICE INFORMATION >

1. Press the top of the fan switch. Fan should operate.
2. Press the top of the fan switch and continue checking fan speed and fan symbol until all speeds are checked.

Can the symptom be duplicated?

- YES >> GO TO 3.
NO >> GO TO 2.

2.PERFORM COMPLETE OPERATIONAL CHECK

Perform a complete operational check and check for any symptoms. Refer to [ATC-40, "Operational Check"](#).

Can a symptom be duplicated?

- YES >> Refer to [ATC-25, "How to Perform Trouble Diagnosis for Quick and Accurate Repair"](#).
NO >> System OK.

3.CHECK FOR SERVICE BULLETINS

Check for any service bulletins.

>> GO TO 4.

4.PERFORM FRONT AIR CONTROL SELF-DIAGNOSIS

Perform front air control self-diagnosis. Refer to [ATC-90, "Front Air Control Self - Diagnosis"](#).

OK or NG

- OK >> GO TO 5.
NG >> Perform power and ground circuit for front air control. Refer to [ATC-42, "Power Supply and Ground Circuit for Front Air Control and Unified Meter and A/C Amp"](#).

5.PERFORM SELF-DIAGNOSIS STEP - 2

Perform self-diagnosis STEP - 2. Refer to [ATC-34, "A/C System Self-Diagnosis Function"](#).

OK or NG

- OK >> GO TO 6.
NG >> Perform the appropriate malfunctioning sensor circuit.

6.PERFORM SELF-DIAGNOSIS STEP - 4

Perform self-diagnosis STEP - 4. Refer to [ATC-34, "A/C System Self-Diagnosis Function"](#).

Code No.	41	42	43	44	45	46
Blower motor voltage	5V	11.75V	8.5V	8.5V	8.5V	11.75V

Does blower motor speed change according to each code No.?

- YES >> GO TO 7.
NO >> Check blower motor circuit. Refer to "DIAGNOSTIC PROCEDURE FOR BLOWER MOTOR".

7.CHECK ENGINE COOLANT TEMPERATURE

Check engine coolant temperature.

Is engine coolant temperature below 56°C (133°F)?

- YES >> GO TO 8.
NO >> Blower motor operation is normal.

8.CHECK BLOWER MOTOR SPEED

Check blower motor speed.

Is blower motor operating under starting blower speed control?

- YES >> GO TO 9.
NO >> Check blower motor circuit. Refer to "DIAGNOSTIC PROCEDURE FOR BLOWER MOTOR".

9.CHECK AMBIENT SENSOR CIRCUIT (CAUSE CANNOT BE CONFIRMED BY SELF-DIAGNOSIS)

Perform diagnostic procedure for the ambient sensor circuit. Refer to [ATC-77, "Ambient Sensor Circuit"](#).

OK or NG

- OK >> GO TO 10.

TROUBLE DIAGNOSIS

< SERVICE INFORMATION >

NG >> Repair as necessary.

10. CHECK IN-VEHICLE SENSOR CIRCUIT

Perform diagnostic procedure for the in-vehicle sensor circuit. Refer to [ATC-80, "In-vehicle Sensor Circuit"](#).

OK or NG

OK >> GO TO 11.

NG >> Repair as necessary.

11. CHECK SUNLOAD SENSOR CIRCUIT

Perform diagnostic procedure for the sunload sensor circuit. Refer to [ATC-82, "Sunload Sensor Circuit"](#).

OK or NG

OK >> GO TO 12.

NG >> Repair as necessary.

12. CHECK INTAKE SENSOR CIRCUIT

Perform diagnostic procedure for the intake sensor circuit. Refer to [ATC-85, "Intake Sensor Circuit"](#).

OK or NG

OK >> If the symptom still exists, perform a complete operational check and check for other symptoms. Refer to [ATC-40, "Operational Check"](#). and check for other symptoms. Refer to [ATC-25, "How to Perform Trouble Diagnosis for Quick and Accurate Repair"](#). If no other symptom exists replace unified meter and A/C amp. Refer to [ATC-92](#).

NG >> Repair as necessary.

SYSTEM DESCRIPTION

Component Parts

Fan speed control system components are:

- Unified meter and A/C amp.
- In-vehicle sensor
- Ambient sensor
- Sunload sensor
- Intake sensor
- Fan control amp.
- Front air control

System Operation

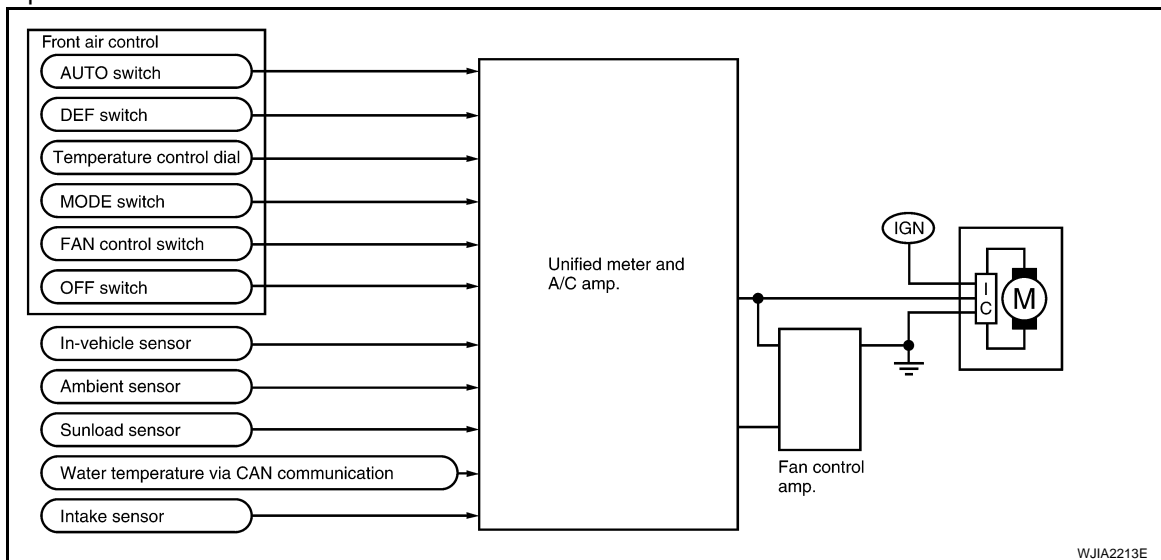

Automatic Mode

In the automatic mode, the blower motor speed is calculated by the unified meter and A/C amp. based on input from the PBR, in-vehicle sensor, sunload sensor, intake sensor and ambient sensor.

When the air flow is increased, the duty ratio of the blower fan motor's drive signal is changed at 8%/sec. to prevent a sudden increase in air flow.

TROUBLE DIAGNOSIS

< SERVICE INFORMATION >

In addition to manual air flow control and the usual automatic air flow control, starting air flow control, low water temperature starting control and high passenger compartment temperature starting control are available.

Starting Blower Speed Control

Start Up From COLD SOAK Condition (Automatic mode)

In a cold start up condition where the engine coolant temperature is below 56°C (133°F), the blower will not operate for a short period of time (up to 150 seconds). The exact start delay time varies depending on the ambient and engine coolant temperature.

In the most extreme case (very low ambient) the blower starting delay will be 150 seconds as described above. After this delay, the blower will operate at low speed until the engine coolant temperature rises above 56°C (133°F), at which time the blower speed will increase to the objective speed.

Start Up From Usual or HOT SOAK Condition (Automatic mode)

The blower will begin operation momentarily after the AUTO switch is pushed. The blower speed will gradually rise to the objective speed over a time period of 3 seconds or less (actual time depends on the objective blower speed).

Blower Speed Compensation

When the in-vehicle temperature and the set temperature are very close, the blower will be operating at low speed.

Sunload

When the in-vehicle temperature and the set temperature are very close, the blower will be operating at low speed. The low speed will vary depending on the sunload. During conditions of low or no sunload, the blower low speed is usual low speed (duty ratio 25%). During high sunload conditions, the display and unified meter and A/C amp. causes the blower speed to increase (duty ratio 49%).

Blower Speed Control Specification

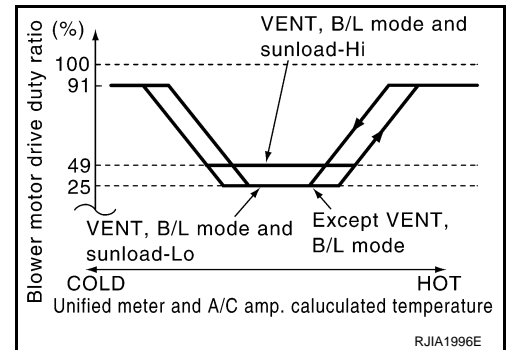

COMPONENT DESCRIPTION

Fan Control Amp.

The fan control amplifier is located on the cooling unit. The fan control amp. receives a gate voltage from the unified meter and A/C amp. to steplessly maintain the blower fan motor voltage in the 5 to 12 volt range (approx.).

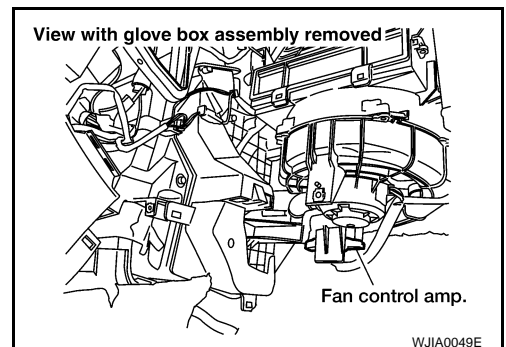

DIAGNOSTIC PROCEDURE FOR BLOWER MOTOR

TROUBLE DIAGNOSIS

< SERVICE INFORMATION >

SYMPTOM: Blower motor operation is malfunctioning under starting fan speed control.

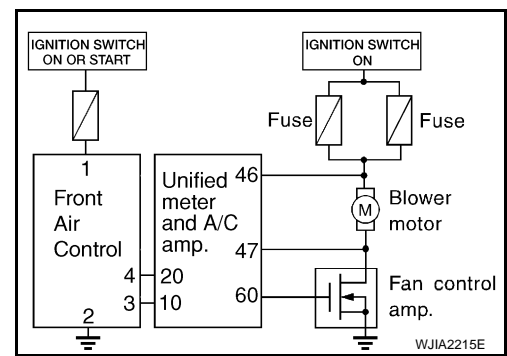

1. CHECK POWER SUPPLY FOR BLOWER MOTOR

1. Disconnect blower motor harness connector.
2. Turn ignition switch ON.
3. Check voltage between blower motor harness connector M62 terminal 1 and ground.

Terminal		Voltage (V) (Approx.)
(+)	(-)	
Connector - Terminal	Body ground	12V
M62-1		

OK or NG

- OK >> GO TO 2.
 NG >> Check power supply circuit and 15A fuses [Nos. 10 and 11, located in the fuse block (J/B)].
- Check blower motor relay. Refer to [PG-5, "Wiring Diagram - POWER -"](#)
 - If OK, check for open circuit in wiring harness. Repair or replace as necessary.
 - If OK, replace fuse and check wiring harness for short circuit. Repair or replace as necessary.

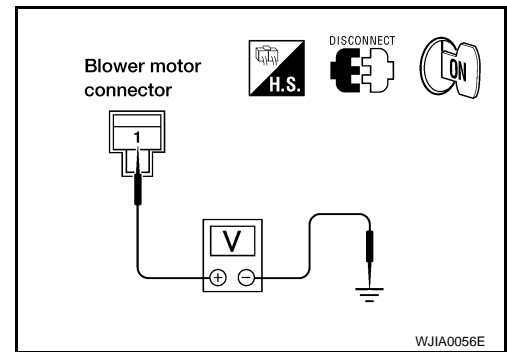

2. CHECK BLOWER MOTOR

Check blower motor. Refer to "Front Blower Motor".

OK or NG

- OK >> GO TO 3.
 NG >> Replace blower motor. Refer to [ATC-98](#).

3. CHECK CIRCUIT CONTINUITY BETWEEN BLOWER MOTOR AND FAN CONTROL AMP.

1. Turn ignition switch OFF.
2. Disconnect fan control amp.
3. Check continuity between blower motor harness connector M62 terminal 2 and fan control amp. harness connector M64 terminal 3.

Terminals		Continuity
Connector - Terminal	Connector	
M62-2	M64-3	Yes

OK or NG

- OK >> GO TO 4.
 NG >> Repair harness or connector.

4. CHECK VOLTAGE FOR FAN CONTROL AMP.

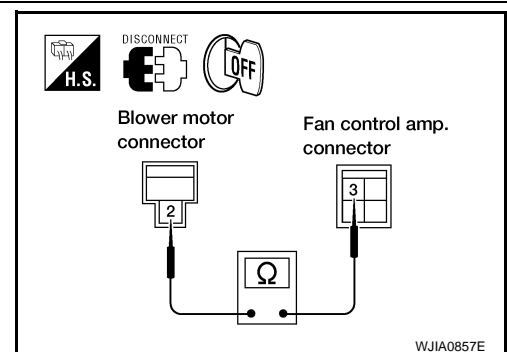

TROUBLE DIAGNOSIS

< SERVICE INFORMATION >

1. Turn ignition switch ON.
2. Press fan switch to any position except OFF or AUTO.
3. Check voltage between fan control amp. harness connector M64 terminal 2 and ground.

Terminals		Voltage (V) (Approx.)
(+)	(-)	
Connector - Terminal	Body ground	12V
M64-2		

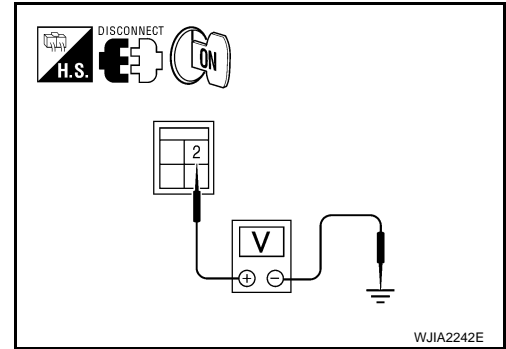

OK or NG

- OK >> GO TO 5.
NG >> GO TO 7.

5. CHECK CIRCUIT CONTINUITY BETWEEN UNIFIED METER AND A/C AMP. AND FAN CONTROL AMP.

1. Turn ignition switch OFF.
2. Disconnect unified meter and A/C amp.
3. Check continuity between unified meter and A/C amp. harness connector M89 (A) terminal 47 and fan control amp. harness connector M64 (B) terminal 3.

Terminals		Continuity
Connector - Terminal	Connector	
M89-47	M64-3	Yes

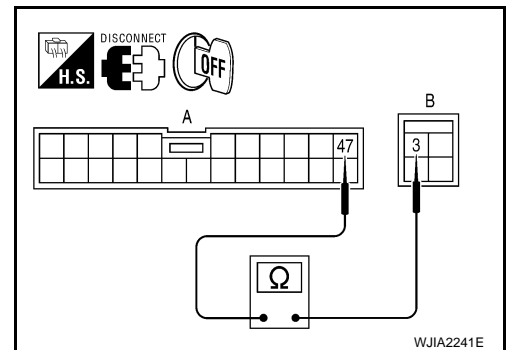

OK or NG

- OK >> GO TO 6.
NG >> Repair harness or connector.

6. CHECK BODY GROUND CIRCUIT FOR FAN CONTROL AMP.

Check continuity between fan control amp. harness connector M64 terminal 1 and ground.

Terminals		Continuity
Connector - Terminal	Body ground	
M64-1		Yes

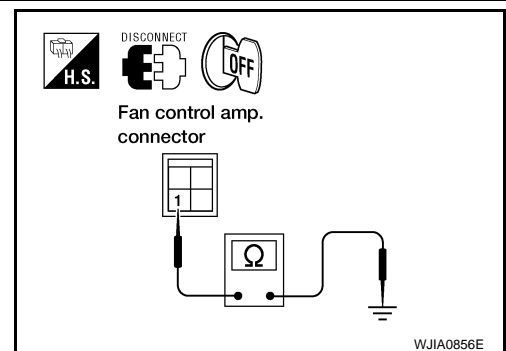

OK or NG

- OK >> 1. Replace fan control amp. Refer to [ATC-105](#).
2. Confirm that blower motor operation is normal.
NG >> Repair harness or connector.

7. CHECK FAN CONTROL AMP. CIRCUIT BETWEEN FAN CONTROL AMP. AND UNIFIED METER AND A/C AMP.

1. Turn ignition switch OFF.
2. Disconnect unified meter and A/C amp. connector.
3. Check continuity between fan control amp. harness connector M64 terminal 2 and unified meter and A/C amp. harness connector M89 terminal 60.
- 4.

Terminals		Continuity
Connector - Terminal	Connector	
M64-2	M89-60	Yes

If OK, check harness for short.

OK or NG

- OK >> 1. Replace unified meter and A/C amp. Refer to [ATC-92](#), "Removal and Installation".

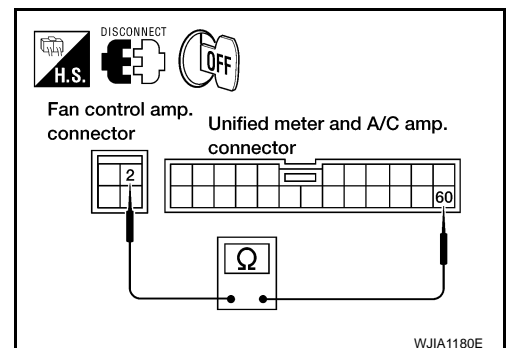

TROUBLE DIAGNOSIS

< SERVICE INFORMATION >

2. Confirm that blower motor operation is normal.
NG >> Repair harness or connector.

COMPONENT INSPECTION

Front Blower Motor

Confirm smooth rotation of the blower motor.

- Ensure that there are no foreign particles inside the blower unit.
- Apply 12 volts to terminal 1 and ground to terminal 2 and verify that the motor operates freely and quietly.

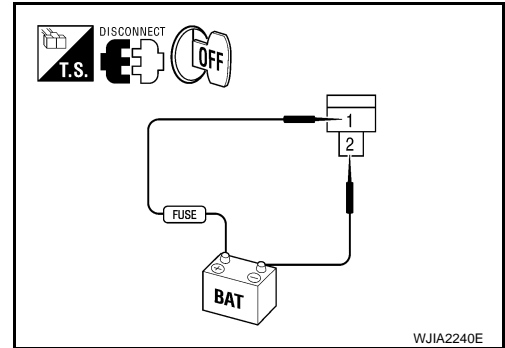

Magnet Clutch Circuit

INFOID:000000001721313

SYMPTOM: Magnet clutch does not engage.

INSPECTION FLOW

1. CONFIRM SYMPTOM BY PERFORMING OPERATIONAL CHECK - MAGNET CLUTCH

1. Turn ignition switch ON.
2. Press the AUTO switch.
3. Confirm that the compressor clutch engages (sound or visual inspection). (Discharge air and blower speed will depend on ambient, in-vehicle and set temperatures.)

Can the symptom be duplicated?

- YES >> GO TO 3.
NO >> GO TO 2.

2. CHECK FOR ANY SYMPTOMS

Perform a complete operational check for any symptoms. Refer to [ATC-40, "Operational Check"](#).

Does another symptom exist?

- YES >> Refer to [ATC-25, "How to Perform Trouble Diagnosis for Quick and Accurate Repair"](#).
NO >> System OK.

3. CHECK FOR SERVICE BULLETINS

Check for any service bulletins.

>> GO TO 4.

4. PERFORM FRONT AIR CONTROL SELF-DIAGNOSIS

Perform front air control self-diagnosis. Refer to [ATC-90, "Front Air Control Self - Diagnosis"](#).

OK or NG

- OK >> GO TO 5.
NG >> Perform power and ground circuit for front air control. Refer to [ATC-42, "Power Supply and Ground Circuit for Front Air Control and Unified Meter and A/C Amp"](#).

5. PERFORM SELF-DIAGNOSIS STEP - 2

Perform self-diagnosis STEP - 2. Refer to [ATC-34, "A/C System Self-Diagnosis Function"](#).

OK or NG

- OK >> GO TO 6.
NG >> Check appropriate malfunctioning sensor circuit.

TROUBLE DIAGNOSIS

< SERVICE INFORMATION >

6. PERFORM SELF-DIAGNOSIS STEP - 4

Perform self-diagnosis STEP - 4. Refer to [ATC-34. "A/C System Self-Diagnosis Function"](#).

OK and NG

OK >> GO TO 7.

NG >> Check for refrigerant pressure. Refer to [ATC-65. "Insufficient Cooling"](#)

7. CHECK AMBIENT SENSOR CIRCUIT (CAUSE CANNOT BE CONFIRMED BY SELF-DIAGNOSIS.)

Perform diagnostic procedure for the ambient sensor circuit. Refer to [ATC-77. "Ambient Sensor Circuit"](#).

OK or NG

OK >> GO TO 8.

NG >> Repair as necessary.

8. CHECK INTAKE SENSOR CIRCUIT

Perform diagnostic procedure for the intake sensor circuit. Refer to [ATC-85. "Intake Sensor Circuit"](#).

OK or NG

OK >> If the symptom still exists, perform a complete operational check. Refer to [ATC-40. "Operational Check"](#) and check for other symptoms. Refer to [ATC-25. "How to Perform Trouble Diagnosis for Quick and Accurate Repair"](#). If no other symptom exists replace unified meter and A/C amp. Refer to [ATC-92](#).

NG >> Repair as necessary.

SYSTEM DESCRIPTION

Unified meter and A/C amp. controls compressor operation by ambient temperature and signal from ECM.

Low Temperature Protection Control

Unified meter and A/C amp. will turn the compressor ON or OFF as determined by a signal detected by intake sensor.

When intake air temperature is higher than 4°C (39°F), the compressor turns ON. The compressor turns OFF when intake air temperature is lower than 2.5°C (37°F).

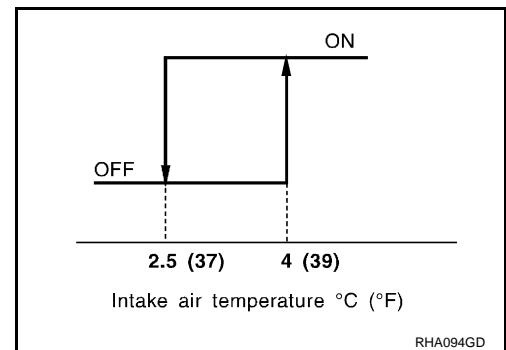

DIAGNOSTIC PROCEDURE FOR MAGNET CLUTCH

SYMPTOM: Magnet clutch does not engage when A/C switch is ON.

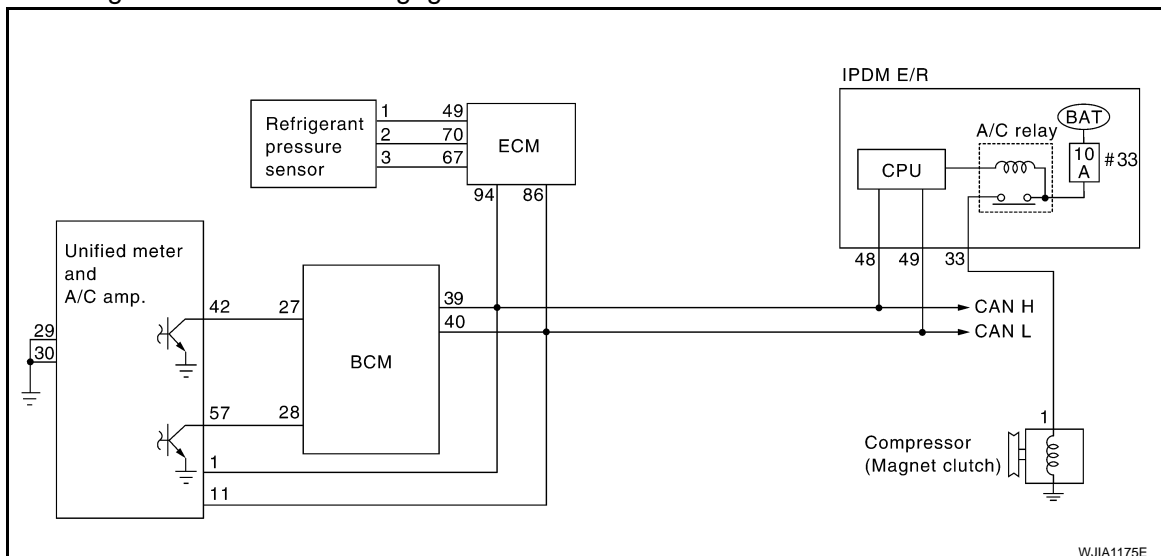

TROUBLE DIAGNOSIS

< SERVICE INFORMATION >

1. CHECK INTAKE SENSOR CIRCUIT

Check intake sensor. Refer to [ATC-34. "A/C System Self-Diagnosis Function"](#).

OK or NG

OK >> GO TO 2.

NG >> Malfunctioning intake sensor. Refer to [ATC-85. "Intake Sensor Circuit"](#).

2. PERFORM AUTO ACTIVE TEST

Refer to [PG-21. "Auto Active Test"](#).

Does magnet clutch operate?

YES or NO

YES >> • WITH CONSULT-III
GO TO 5.

• WITHOUT CONSULT-III
GO TO 6.

NO >> Check 10A fuse (No. 33, located in IPDM E/R), and GO TO 3.

3. CHECK CIRCUIT CONTINUITY BETWEEN IPDM E/R AND COMPRESSOR

1. Turn ignition switch OFF.
2. Disconnect IPDM E/R connector and compressor (magnet clutch) connector.
3. Check continuity between IPDM E/R harness connector E124 terminal 33 and compressor harness connector F3 terminal 1.

33 – 1 : Continuity should exist.

OK or NG

OK >> GO TO 4.

NG >> Repair harness or connector.

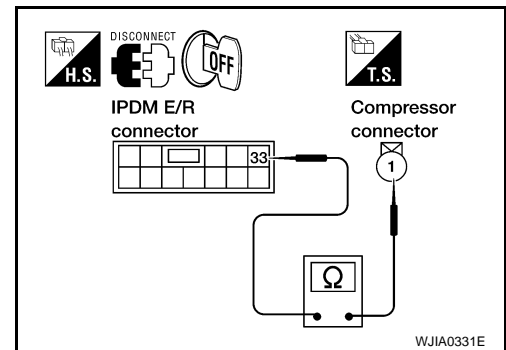

4. CHECK MAGNET CLUTCH OPERATION

Check for operation sound when applying battery voltage direct current to terminal.

OK or NG

OK >> Replace IPDM E/R. Refer to [PG-29. "Removal and Installation of IPDM E/R"](#).

NG >> Replace magnet clutch. Refer to [ATC-112. "Removal and Installation for Compressor Clutch"](#).

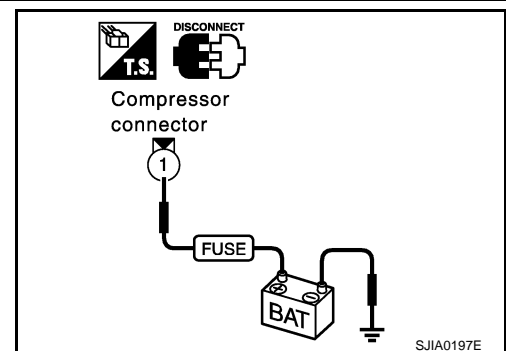

5. CHECK BCM INPUT (COMPRESSOR ON) SIGNAL

Check compressor ON/OFF signal. Refer to [ATC-25. "CONSULT-III Function \(BCM\)"](#).

A/C SW ON : COMP ON SIG ON

A/C SW OFF : COMP ON SIG OFF

OK or NG

OK >> GO TO 8.

NG >> GO TO 6.

6. CHECK CIRCUIT CONTINUITY BETWEEN BCM AND UNIFIED METER AND A/C AMP.

TROUBLE DIAGNOSIS

< SERVICE INFORMATION >

1. Turn ignition switch OFF.
2. Disconnect BCM connector and unified meter and A/C amp. connector.
3. Check continuity between BCM harness connector M18 terminal 27 and unified meter and A/C amp. harness connector M89 terminal 42.

27 – 42 : Continuity should exist.

OK or NG

- OK >> GO TO 7.
 NG >> Repair harness or connector.

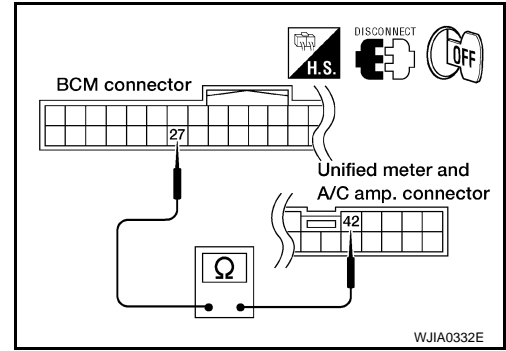

7. CHECK VOLTAGE FOR UNIFIED METER AND A/C AMP. (COMPRESSOR ON SIGNAL)

1. Reconnect BCM connector and unified meter and A/C amp. connector.
2. Turn ignition switch ON.
3. Check voltage between unified meter and A/C amp. harness connector M89 terminal 42 and ground.

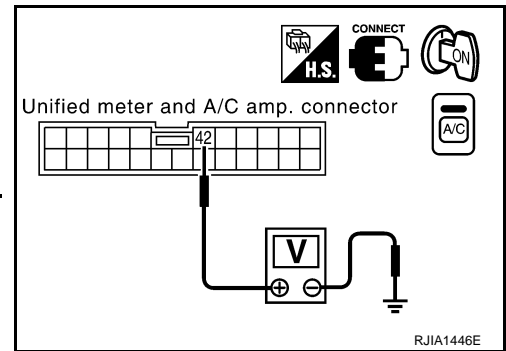

Terminals		(-)	Condition	Voltage (Approx.)
(+)	Terminal No.			
Unified meter and A/C amp. connector				
M89	42	Ground	A/C switch: ON	0V
			A/C switch: OFF	5V

OK or NG

- OK >> GO TO 8.
 NG-1 >> If the voltage is approx. 5V when A/C switch is ON: Replace unified meter and A/C amp. Refer to [ATC-92](#).
 NG-2 >> If the voltage is approx. 0V when A/C switch is OFF: Replace BCM. Refer to [BCS-18, "BCM"](#).

8. CHECK REFRIGERANT PRESSURE SENSOR

Ⓜ WITH CONSULT-III

1. Start engine.
2. Check voltage of refrigerant pressure sensor. Refer to [ATC-25, "CONSULT-III Function \(BCM\)"](#).

ⓧ WITHOUT CONSULT-III

1. Start engine.
2. Check voltage between ECM harness connector F54 terminal 70 and ground.

Terminals		(-)	Condition	Voltage (Approx.)
(+)	Terminal No.			
ECM connector				
F54	70	Ground	A/C switch: ON	3.60 - 3.88V

OK or NG

- OK >> • Ⓜ WITH CONSULT-III
 GO TO 9.
 • ⓧ WITHOUT CONSULT-III
 GO TO 10.
 NG >> Refer to [EC-568](#).

9. CHECK BCM INPUT (FAN ON) SIGNAL

Check FAN ON/OFF signal. Refer to [ATC-25, "CONSULT-III Function \(BCM\)"](#).

TROUBLE DIAGNOSIS

< SERVICE INFORMATION >

FAN CONTROL SWITCH ON : FAN ON SIG ON
FAN CONTROL SWITCH OFF : FAN ON SIG OFF

OK or NG

OK >> GO TO 12.
 NG >> GO TO 10.

10. CHECK CIRCUIT CONTINUITY BETWEEN BCM AND UNIFIED METER AND A/C AMP.

1. Turn ignition switch OFF.
2. Disconnect BCM connector and unified meter and A/C amp. connector.
3. Check continuity between BCM harness connector M18 (A) terminal 28 and unified meter and A/C amp. harness connector M89 (B) terminal 57.

28 – 57 : Continuity should exist.

OK or NG

OK >> GO TO 11.
 NG >> Repair harness or connector.

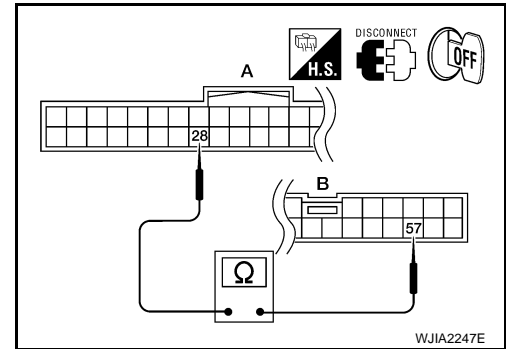

11. CHECK VOLTAGE FOR UNIFIED METER AND A/C AMP. (FAN ON SIGNAL)

1. Reconnect BCM connector and unified meter and A/C amp. connector.
2. Turn ignition switch ON.
3. Check voltage between unified meter and A/C amp. harness connector M89 terminal 57 and ground.

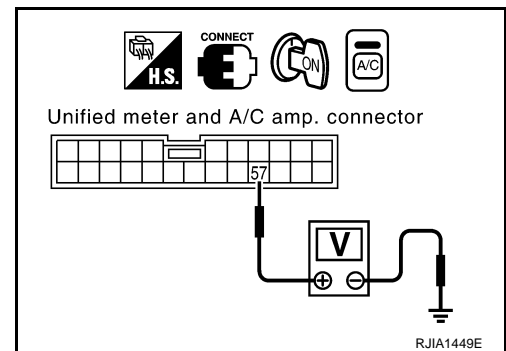

Terminals		(-)	Condition	Voltage (Approx.)
(+)	Terminal No.			
Unified meter and A/C amp. connector				
M89	57	Ground	A/C switch: ON Blower motor operates	0V
			A/C switch: OFF	5V

OK or NG

OK >> GO TO 12.
 NG-1 >> If the voltage is approx. 5V when blower motor is ON: Replace unified meter and A/C amp. [ATC-92](#).
 NG-2 >> If the voltage is approx. 0V when blower motor is OFF: Replace BCM. Refer to [BCS-18. "BCM"](#).

12. CHECK CAN COMMUNICATION

Check CAN communication. Refer to [LAN-38](#).

- BCM – ECM
- ECM – IPDM E/R
- ECM – Unified meter and A/C amp.

OK or NG

OK >> Inspection End
 NG >> Repair or replace malfunctioning part(s).

Insufficient Cooling

SYMPTOM: Insufficient cooling

INSPECTION FLOW

TROUBLE DIAGNOSIS

< SERVICE INFORMATION >

1. CONFIRM SYMPTOM BY PERFORMING OPERATIONAL CHECK - TEMPERATURE DECREASE

1. Press the AUTO switch.
2. Turn temperature control dial (driver) counterclockwise until 16° C (32° F) is displayed.
3. Check for cold air at discharge air outlets.

Can the symptom be duplicated?

- YES >> GO TO 3.
NO >> GO TO 2.

2. CHECK FOR ANY SYMPTOMS

Perform a complete operational check for any symptoms. Refer to [ATC-40. "Operational Check"](#).

Does another symptom exist?

- YES >> Refer to [ATC-25. "How to Perform Trouble Diagnosis for Quick and Accurate Repair"](#).
NO >> System OK.

3. CHECK FOR SERVICE BULLETINS

Check for any service bulletins.

>> GO TO 4.

4. PERFORM FRONT AIR CONTROL SELF-DIAGNOSIS

Perform front air control self-diagnosis. Refer to [ATC-90. "Front Air Control Self - Diagnosis"](#).

OK or NG

- OK >> GO TO 5.
NG >> Perform power and ground circuit for front air control. Refer to [ATC-42. "Power Supply and Ground Circuit for Front Air Control and Unified Meter and A/C Amp"](#).

5. PERFORM SELF-DIAGNOSIS STEP - 2

Perform self-diagnosis STEP - 2. Refer to [ATC-34. "A/C System Self-Diagnosis Function"](#).

OK or NG

- OK >> GO TO 6.
NG >> Perform appropriate malfunctioning sensor circuit.

6. PERFORM SELF-DIAGNOSIS STEP - 4

Perform self-diagnosis STEP - 4. Refer to [ATC-34. "A/C System Self-Diagnosis Function"](#).

OK and NG

- OK >> GO TO 7.
NG >> • Check Magnet clutch mechanism. Refer to [ATC-61. "Magnet Clutch Circuit"](#).
• Check LAN system circuit. Refer to [ATC-45. "LAN System Circuit"](#).
• Check blower motor circuit. Refer to [ATC-55. "Blower Motor Circuit"](#).

7. CHECK COMPRESSOR DRIVE BELT TENSION

Check compressor belt tension. Refer to [EM-13. "Checking Drive Belts"](#).

OK or NG

- OK >> GO TO 8.
NG >> Adjust or replace compressor belt. Refer to [EM-13. "Adjusting Drive Belts"](#).

8. CHECK AIR MIX DOOR OPERATION

Check and verify air mix door operation. Refer to [ATC-50. "Air Mix Door Motor Circuit"](#).

Does air mix door operate correctly?

- YES >> GO TO 9.
NO >> Repair or replace air mix door control linkage.

9. CHECK COOLING FAN MOTOR OPERATION

Check and verify cooling fan motor for smooth operation. Refer to [EC-433. "Description"](#).

Does cooling fan motor operate correctly?

- YES >> GO TO 10.

TROUBLE DIAGNOSIS

< SERVICE INFORMATION >

NO >> Check cooling fan motor. Refer to [EC-433](#).

10.CHECK RECOVERY/RECYCLING EQUIPMENT BEFORE USAGE

Check recovery/recycling equipment before connecting to vehicle. Verify there is no pressure in the recovery/recycling equipment by checking the gauges. If pressure exists, recover refrigerant from equipment lines.

>> GO TO 11.

11.CHECK REFRIGERANT PURITY

1. Connect recovery/recycling equipment to vehicle.
2. Confirm refrigerant purity in supply tank using recovery/recycling and refrigerant identifier.

OK or NG

OK >> GO TO 12.

NG >> Check contaminated refrigerant. Refer to [ATC-3, "Contaminated Refrigerant"](#).

12.CONNECT ACR2005 TO VEHICLE

Confirm refrigerant purity in vehicle A/C system using ACR2005 and refrigerant identifier.

OK or NG

OK >> GO TO 13.

NG >> Check contaminated refrigerant. Refer to [ATC-3, "Contaminated Refrigerant"](#).

13.CHECK FOR EVAPORATOR FREEZE UP

Start engine and run A/C. Check for evaporator freeze up.

Does evaporator freeze up?

YES >> Perform performance test diagnoses. Refer to "PERFORMANCE TEST DIAGNOSES".

NO >> GO TO 14.

14.CHECK REFRIGERANT PRESSURE

Check refrigerant pressure with manifold gauge connected. Refer to "Test Reading".

OK or NG

OK >> GO TO 15.

NG >> Perform performance test diagnoses. Refer to "PERFORMANCE TEST DIAGNOSES".

15.CHECK AIR DUCTS

Check ducts for air leaks.

OK or NG

OK >> Perform temperature setting trimmer procedure. Refer to [ATC-34, "A/C System Self-Diagnosis Function"](#).

NG >> Repair air leaks.

PERFORMANCE TEST DIAGNOSES

A
B
C
D
E
F
G
H
I
K
L
M
N
O
P

ATC

TROUBLE DIAGNOSIS

< SERVICE INFORMATION >

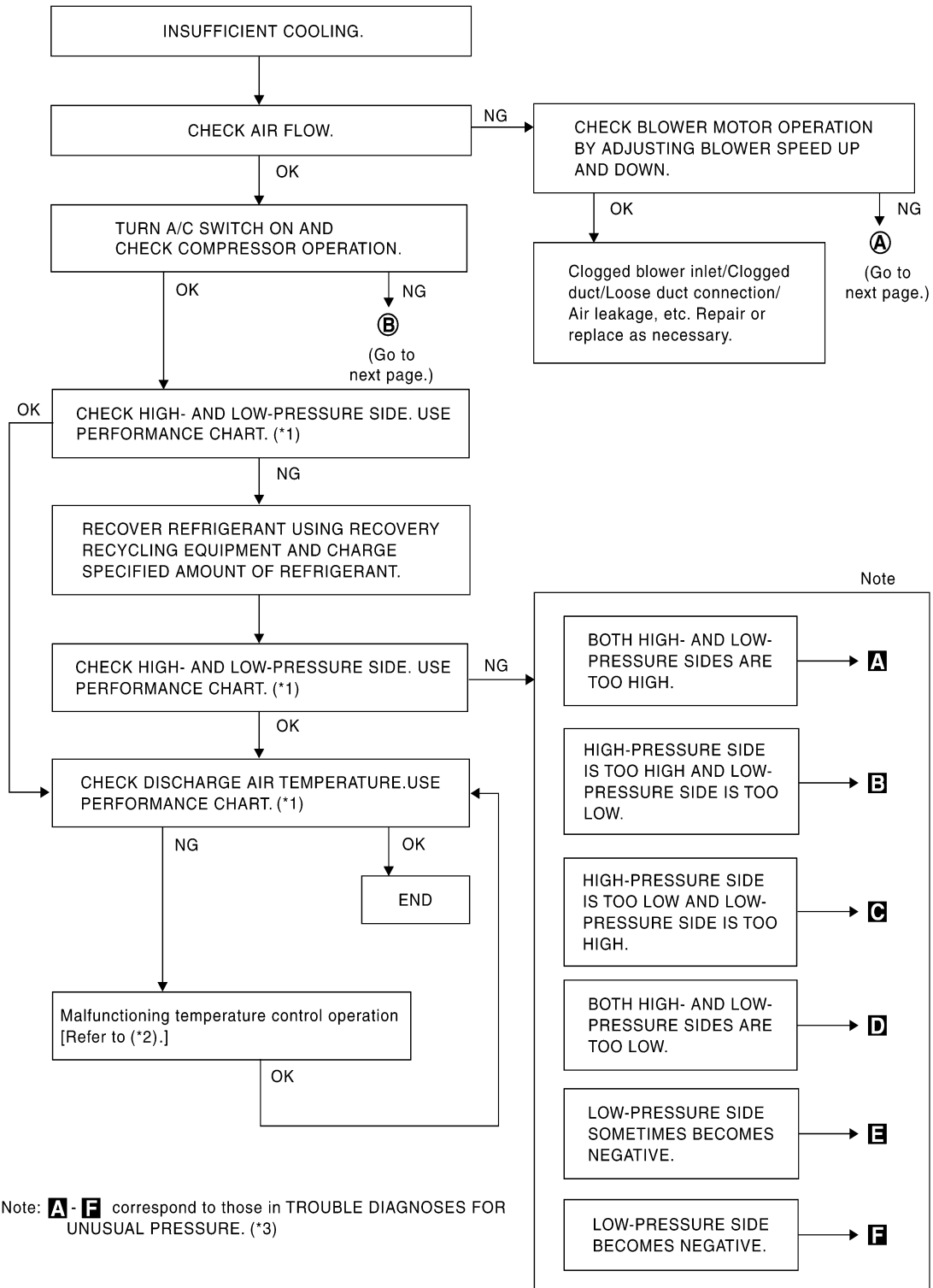

WJIA2248E

*1 "PERFORMANCE CHART"

*2 [ATC-50, "Air Mix Door Motor Circuit"](#)

*3 "Trouble Diagnoses for UNUSUAL Pressure"

TROUBLE DIAGNOSIS

< SERVICE INFORMATION >

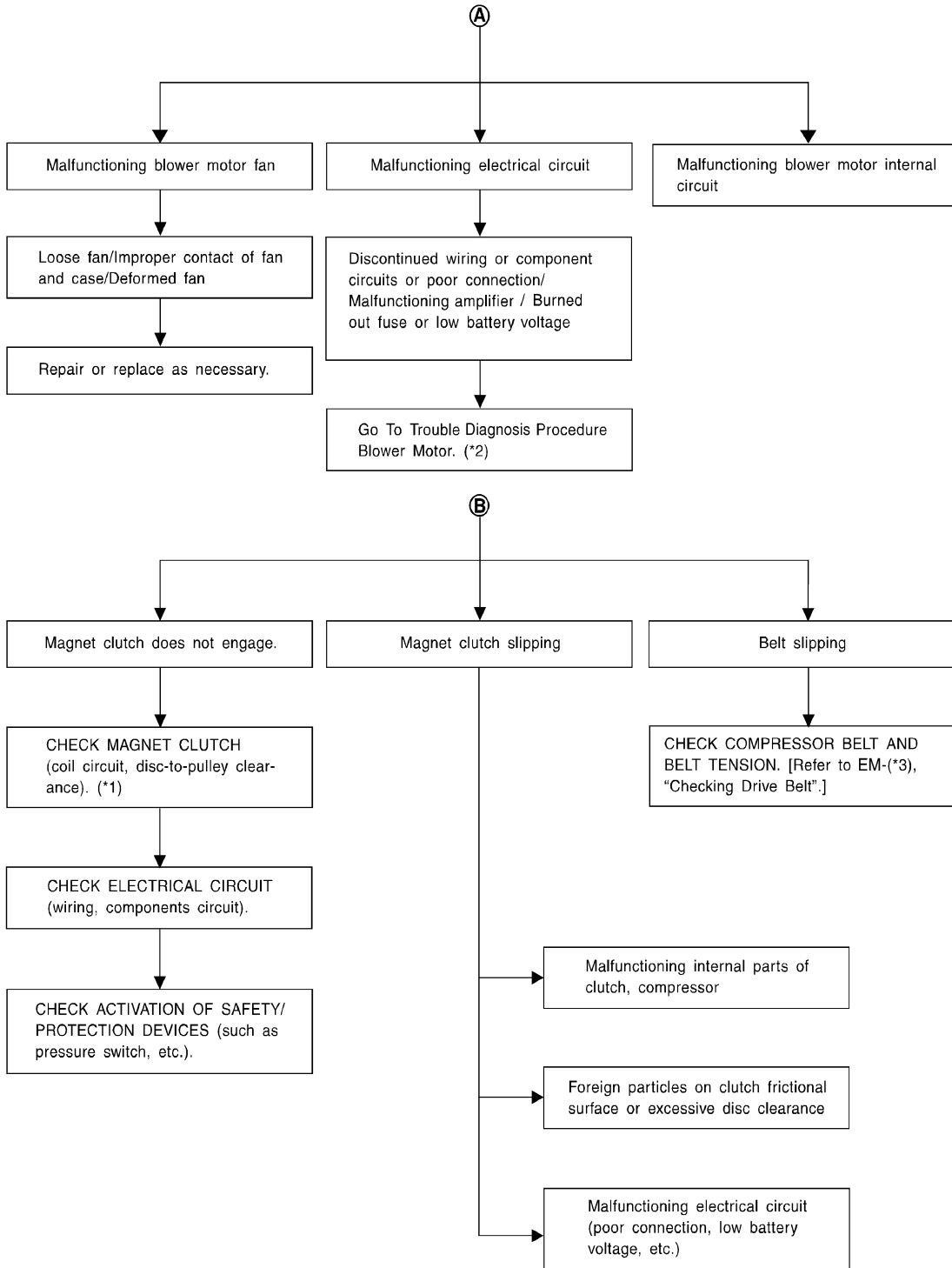

A
B
C
D
E
F
G
H
I
K
L
M
N
O
P

ATC

WJIA0361E

*1 [ATC-112. "Removal and Installation for Compressor Clutch"](#)

*2 [ATC-55. "Blower Motor Circuit"](#)





*3 [EM-13. "Checking Drive Belts"](#)

PERFORMANCE CHART

Test Condition
Testing must be performed as follows:

TROUBLE DIAGNOSIS

< SERVICE INFORMATION >

Vehicle location	Indoors or in the shade (in a well-ventilated place)
Doors	Closed
Door window	Open
Hood	Open
TEMP.	Max. COLD
Mode switch	 (Ventilation) set
Recirculation  (REC) switch	 (Recirculation) set
 Fan (blower) speed	Max. speed set
Engine speed	Idle speed

Operate the air conditioning system for 10 minutes before taking measurements.

Test Reading

Recirculating-to-discharge Air Temperature Table

Inside air (Recirculating air) at blower assembly inlet		Discharge air temperature at center ventilator °C (°F)
Relative humidity %	Air temperature °C (°F)	
50 - 60	20 (68)	5.3 - 6.5 (42 - 44)
	25 (77)	9.7 - 11.5 (49 - 53)
	30 (86)	13.8 - 16.3 (57 - 61)
	35 (95)	18.0 - 21.2 (64 - 70)
	40 (104)	22.2 - 25.7 (72 - 78)
60 - 70	20 (68)	6.5 - 7.7 (44 - 46)
	25 (77)	11.5 - 13.3 (53 - 56)
	30 (86)	16.3 - 18.8 (61 - 66)
	35 (95)	21.2 - 24.0 (70 - 75)
	40 (104)	25.7 - 29.2 (78 - 85)

Ambient Air Temperature-to-operating Pressure Table

Ambient air		High-pressure (Discharge side) kPa (kg/cm ² , psi)	Low-pressure (Suction side) kPa (kg/cm ² , psi)
Relative humidity %	Air temperature °C (°F)		
50 - 70	20 (68)	680 - 840 (6.94 - 8.57, 98.6 - 121.8)	160 - 198 (1.63 - 2.02, 23.2 - 28.7)
	25 (77)	800 - 985 (8.16 - 10.05, 116.0 - 142.8)	198 - 245 (2.02 - 2.50, 28.7 - 35.5)
	30 (86)	940 - 1,150 (9.59 - 11.73, 136.3 - 166.8)	225 - 278 (2.30 - 2.84, 32.6 - 40.3)
	35 (95)	1,160 - 1,410 (11.83 - 14.38, 168.2 - 204.5)	273 - 335 (2.78 - 3.42, 39.6 - 48.6)
	40 (104)	1,325 - 1,620 (13.52 - 16.52, 192.1 - 234.9)	325 - 398 (3.32 - 4.06, 47.1 - 57.7)

Trouble Diagnoses for Unusual Pressure

Whenever system's high and/or low side pressure is unusual, diagnose using a manifold gauge. The marker above the gauge scale in the following tables indicates the standard (usual) pressure range. Since the standard (usual) pressure, however, differs from vehicle to vehicle, refer to above table (Ambient air temperature-to-operating pressure table).

Both High- and Low-pressure Sides are Too High

TROUBLE DIAGNOSIS

< SERVICE INFORMATION >

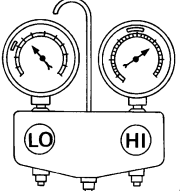
Gauge indication	Refrigerant cycle	Probable cause	Corrective action
<p>Both high- and low-pressure sides are too high.</p>  <p style="text-align: right; font-size: small;">AC359A</p>	<p>Pressure is reduced soon after water is splashed on condenser.</p>	<p>Excessive refrigerant charge in refrigeration cycle</p>	<p>Reduce refrigerant until specified pressure is obtained.</p>
	<p>Air suction by cooling fan is insufficient.</p>	<p>Insufficient condenser cooling performance ↓ 1. Condenser fins are clogged. 2. Improper fan rotation of cooling fan</p>	<ul style="list-style-type: none"> • Clean condenser. • Check and repair cooling fan as necessary.
	<ul style="list-style-type: none"> • Low-pressure pipe is not cold. • When compressor is stopped high-pressure value quickly drops by approximately 196 kPa (2 kg/cm², 28 psi). It then decreases gradually thereafter. 	<p>Poor heat exchange in condenser (After compressor operation stops, high-pressure decreases too slowly.) ↓ Air in refrigeration cycle</p>	<p>Evacuate and recharge system.</p>
	<p>Engine tends to overheat.</p>	<p>Engine cooling systems malfunction.</p>	<p>Check and repair engine cooling system.</p>
	<ul style="list-style-type: none"> • An area of the low-pressure pipe is colder than areas near the evaporator outlet. • Plates are sometimes covered with frost. 	<ul style="list-style-type: none"> • Excessive liquid refrigerant on low-pressure side • Excessive refrigerant discharge flow • Expansion valve is open a little compared with the specification. <p>↓ Improper expansion valve adjustment</p>	<p>Replace expansion valve.</p>

High-pressure Side is Too High and Low-pressure Side is Too Low

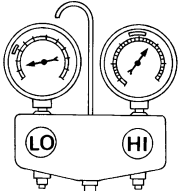
Gauge indication	Refrigerant cycle	Probable cause	Corrective action
<p>High-pressure side is too high and low-pressure side is too low.</p>  <p style="text-align: right; font-size: small;">AC360A</p>	<p>Upper side of condenser and high-pressure side are hot, however, liquid tank is not so hot.</p>	<p>High-pressure tube or parts located between compressor and condenser are clogged or crushed.</p>	<ul style="list-style-type: none"> • Check and repair or replace malfunctioning parts. • Check oil for contamination.

High-pressure Side is Too Low and Low-pressure Side is Too High

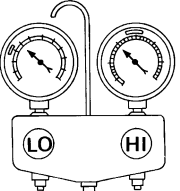
Gauge indication	Refrigerant cycle	Probable cause	Corrective action
<p>High-pressure side is too low and low-pressure side is too high.</p>  <p style="text-align: right; font-size: small;">AC356A</p>	<p>High- and low-pressure sides become equal soon after compressor operation stops.</p>	<p>Compressor pressure operation is improper. ↓ Damaged inside compressor packings</p>	<p>Replace compressor.</p>
	<p>No temperature difference between high- and low-pressure sides</p>	<p>Compressor pressure operation is improper. ↓ Damaged inside compressor packings.</p>	<p>Replace compressor.</p>

Both High- and Low-pressure Sides are Too Low

TROUBLE DIAGNOSIS

< SERVICE INFORMATION >

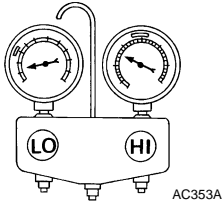
Gauge indication	Refrigerant cycle	Probable cause	Corrective action
<p>Both high- and low-pressure sides are too low.</p>  <p style="text-align: right; font-size: small;">AC353A</p>	<ul style="list-style-type: none"> There is a big temperature difference between liquid tank outlet and inlet. Outlet temperature is extremely low. Liquid tank inlet and expansion valve are frosted. 	Liquid tank inside is slightly clogged.	<ul style="list-style-type: none"> Replace liquid tank. Check oil for contamination.
	<ul style="list-style-type: none"> Temperature of expansion valve inlet is extremely low as compared with areas near liquid tank. Expansion valve inlet may be frosted. Temperature difference occurs somewhere in high-pressure side. 	High-pressure pipe located between liquid tank and expansion valve is clogged.	<ul style="list-style-type: none"> Check and repair malfunctioning parts. Check oil for contamination.
	Expansion valve and liquid tank are warm or only cool when touched.	Low refrigerant charge ↓ Leaking fittings or components	Check refrigerant for leaks. Refer to ATC-119, "Checking of Refrigerant Leaks" .
	There is a big temperature difference between expansion valve inlet and outlet while the valve itself is frosted.	Expansion valve closes a little compared with the specification. ↓ 1. Improper expansion valve adjustment 2. Malfunctioning expansion valve 3. Outlet and inlet may be clogged.	<ul style="list-style-type: none"> Remove foreign particles by using compressed air. Check oil for contamination.
	An area of the low-pressure pipe is colder than areas near the evaporator outlet.	Low-pressure pipe is clogged or crushed.	<ul style="list-style-type: none"> Check and repair malfunctioning parts. Check oil for contamination.
	Air flow volume is not enough or is too low.	Evaporator is frozen.	<ul style="list-style-type: none"> Check intake sensor circuit. Refer to ATC-85, "Intake Sensor Circuit". Replace compressor.

Low-pressure Side Sometimes Becomes Negative

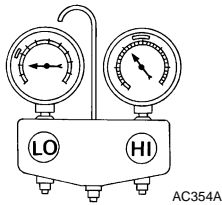
Gauge indication	Refrigerant cycle	Probable cause	Corrective action
<p>Low-pressure side sometimes becomes negative.</p>  <p style="text-align: right; font-size: small;">AC354A</p>	<ul style="list-style-type: none"> Air conditioning system does not function and does not cyclically cool the compartment air. The system constantly functions for a certain period of time after compressor is stopped and restarted. 	Refrigerant does not discharge cyclically. ↓ Moisture is frozen at expansion valve outlet and inlet. ↓ Water is mixed with refrigerant.	<ul style="list-style-type: none"> Drain water from refrigerant or replace refrigerant. Replace liquid tank.

Low-pressure Side Becomes Negative

TROUBLE DIAGNOSIS

< SERVICE INFORMATION >

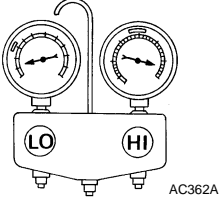
Gauge indication	Refrigerant cycle	Probable cause	Corrective action
<p>Low-pressure side becomes negative.</p>  <p>AC362A</p>	<p>Liquid tank or front/rear side of expansion valve's pipe is frosted or dewed.</p>	<p>High-pressure side is closed and refrigerant does not flow. ↓ Expansion valve or liquid tank is frosted.</p>	<p>Leave the system at rest until no frost is present. Start it again to check whether or not the malfunction is caused by water or foreign particles.</p> <ul style="list-style-type: none"> • If water is the cause, initially cooling is okay. Then the water freezes causing a blockage. Drain water from refrigerant or replace refrigerant. • If due to foreign particles, remove expansion valve and remove the particles with dry and compressed air (not shop air). • If either of the above methods cannot correct the malfunction, replace expansion valve. • Replace liquid tank. • Check oil for contamination.

Insufficient Heating

INFOID:000000001721315

SYMPTOM: Insufficient heating

INSPECTION FLOW

1. CONFIRM SYMPTOM BY PERFORMING OPERATIONAL CHECK - TEMPERATURE INCREASE

1. Press the AUTO switch.
2. Turn the temperature control dial (driver) clockwise until 32° C (90° F) is displayed.
3. Check for hot air at discharge air outlets.

Can this symptom be duplicated?

YES >> GO TO 2.

NO >> Perform complete system operational check. Refer to [ATC-40, "Operational Check"](#).

2. CHECK FOR SERVICE BULLETINS

Check for any service bulletins.

>> GO TO 3.

3. PERFORM FRONT AIR CONTROL SELF-DIAGNOSIS

Perform front air control self-diagnosis. Refer to [ATC-90, "Front Air Control Self - Diagnosis"](#).

OK or NG

OK >> GO TO 4.

NG >> Perform power and ground circuit for front air control. Refer to [ATC-42, "Power Supply and Ground Circuit for Front Air Control and Unified Meter and A/C Amp"](#).

4. PERFORM SELF-DIAGNOSIS STEP - 2

Perform self-diagnosis STEP - 2. Refer to [ATC-34, "A/C System Self-Diagnosis Function"](#).

OK or NG

OK >> GO TO 5.

NG >> Perform appropriate malfunctioning sensor circuit.

5. PERFORM SELF-DIAGNOSIS STEP - 4

Perform self-diagnosis STEP - 4. Refer to [ATC-34, "A/C System Self-Diagnosis Function"](#).

OK and NG

OK >> GO TO 6.

TROUBLE DIAGNOSIS

< SERVICE INFORMATION >

- NG >> • Check LAN system circuit. Refer to [ATC-45. "LAN System Circuit"](#).
• Check blower motor circuit. Refer to [ATC-55. "Blower Motor Circuit"](#).

6. CHECK ENGINE COOLING SYSTEM

1. Check for proper engine coolant level. Refer to [CO-9. "System Inspection"](#).
2. Check hoses for leaks or kinks.
3. Check radiator cap. Refer to [CO-9. "System Inspection"](#).
4. Check for air in cooling system.

OK or NG

- OK >> GO TO 7.
NG >> Repair as necessary.

7. CHECK AIR MIX DOOR OPERATION

Check the operation of the air mix door.

OK or NG

- OK >> GO TO 8.
NG >> Check the air mix door motor circuit. Refer to [ATC-50. "Air Mix Door Motor Circuit"](#).

8. CHECK AIR DUCTS

Check for disconnected or leaking air ducts.

OK or NG

- OK >> GO TO 9.
NG >> Repair all disconnected or leaking air ducts.

9. CHECK HEATER HOSE TEMPERATURES

1. Start engine and warm it up to normal operating temperature.
2. Touch both the inlet and outlet heater hoses.

OK or NG

- OK >> Hot inlet hose and a warm outlet hose: GO TO 10.
NG >> Both hoses warm: GO TO 11.

10. CHECK ENGINE COOLANT SYSTEM

Check engine control temperature sensor. Refer to [EC-186](#).

OK or NG

- OK >> System OK.
NG >> Repair or replace as necessary. Retest.

11. CHECK HEATER HOSES

Check heater hoses for proper installation.

OK or NG

- OK >> System OK.
NG >> 1. Back flush heater core.
2. Drain the water from the system.
3. Refill system with new engine coolant. Refer to [CO-10. "Changing Engine Coolant"](#).
4. GO TO 12 to retest.

12. CHECK HEATER HOSE TEMPERATURES

1. Start engine and warm it up to normal operating temperature.
2. Touch both the inlet and outlet heater hoses.

OK or NG

- OK >> System OK.
NG >> Replace heater core. Refer to [ATC-102](#).

Noise

INFOID:000000001721316

SYMPTOM: Noise

INSPECTION FLOW

TROUBLE DIAGNOSIS

< SERVICE INFORMATION >

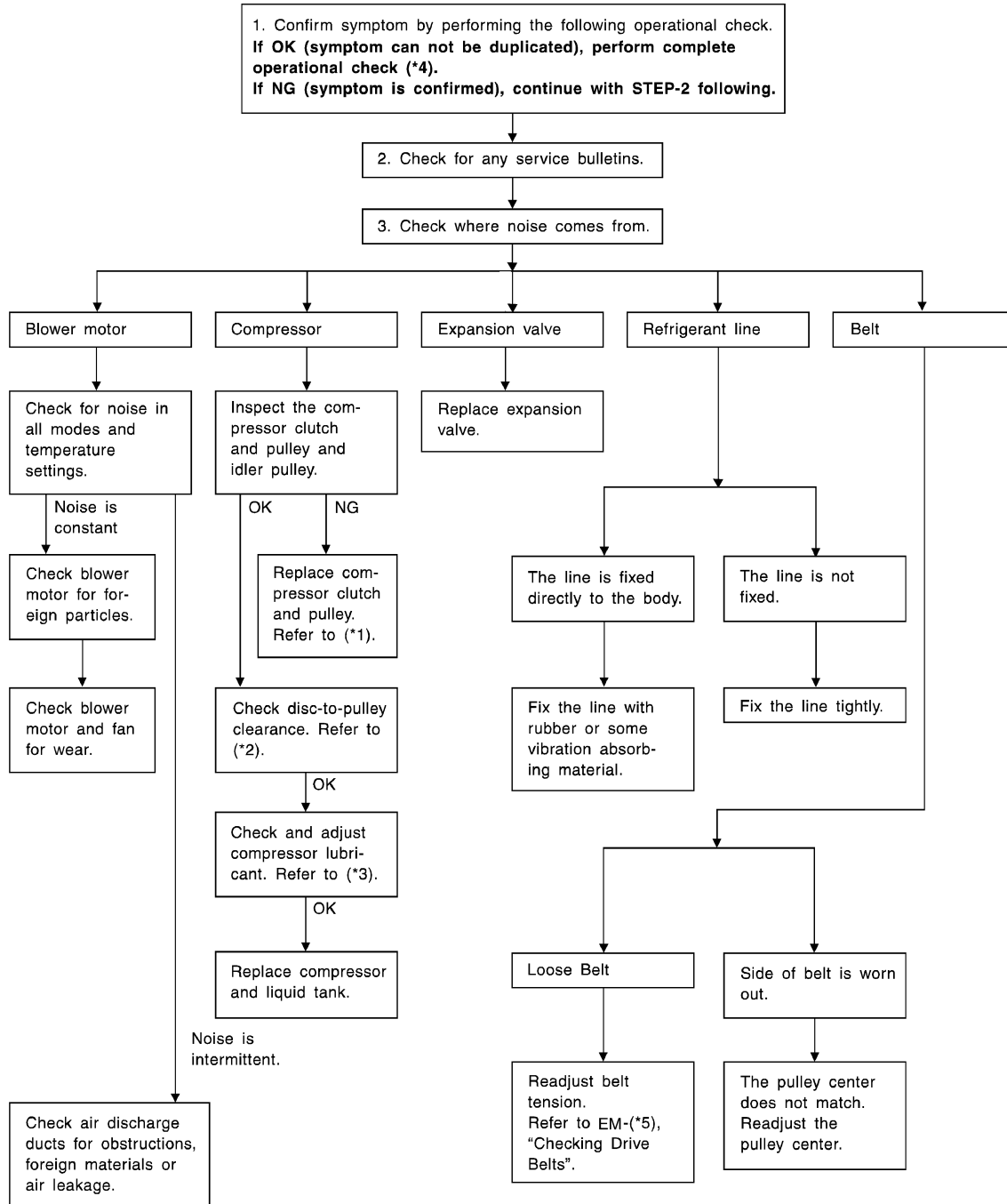

RJA1596E

*1 [ATC-112, "Removal and Installation for Compressor Clutch"](#)

*2 [ATC-112, "Removal and Installation for Compressor Clutch"](#)

*3 [ATC-16, "Maintenance of Oil Quantity in Compressor"](#)

*4 [ATC-40, "Operational Check"](#)

*5 [EM-13, "Checking Drive Belts"](#)

Self-Diagnosis

SYMPTOM: Self-diagnosis cannot be performed.

INSPECTION FLOW

1.CONFIRM AUTO MODE OPERATION

TROUBLE DIAGNOSIS

< SERVICE INFORMATION >

1. Press the AUTO switch.
2. Display should indicate AUTO. Confirm that the compressor clutch engages (sound or visual inspection). (Discharge air and blower speed will depend on ambient, in-vehicle and set temperatures.)

OK or NG

- OK >> GO TO 2.
NG >> GO TO 3.

2.PERFORM COMPLETE OPERATIONAL CHECK

Perform a complete operational check and check for any symptoms. Refer to [ATC-40. "Operational Check"](#).

Can a symptom be duplicated?

- YES >> Refer to [ATC-25. "How to Perform Trouble Diagnosis for Quick and Accurate Repair"](#).
NO >> System OK.

3.CHECK FOR SERVICE BULLETINS

Check for any service bulletins.

Have any service bulletins been issued?

- YES >> Refer to appropriate service bulletin.
NO >> GO TO 4.

4.PERFORM FRONT AIR CONTROL SELF-DIAGNOSIS

Perform front air control self-diagnosis. Refer to [ATC-90. "Front Air Control Self - Diagnosis"](#).

OK or NG

- OK >> GO TO 5.
NG >> Perform power and ground circuit for front air control. Refer to [ATC-42. "Power Supply and Ground Circuit for Front Air Control and Unified Meter and A/C Amp"](#).

5.CHECK UNIFIED METER AND A/C AMP. POWER AND GROUND CIRCUIT

Check unified meter and A/C amp. main power supply and ground circuit. Refer to [ATC-42. "Power Supply and Ground Circuit for Front Air Control and Unified Meter and A/C Amp"](#).

OK or NG

- OK >> GO TO 6.
NG >> Repair as necessary.

6.CHECK AMBIENT SENSOR CIRCUIT (CAUSE CANNOT BE CONFIRMED BY SELF-DIAGNOSIS)

Check ambient sensor circuit. Refer to [ATC-77. "Ambient Sensor Circuit"](#).

OK or NG

- OK >> GO TO 7.
NG >> Repair or replace as necessary.

7.CHECK IN-VEHICLE SENSOR CIRCUIT

Check in-vehicle sensor circuit. Refer to [ATC-80. "In-vehicle Sensor Circuit"](#).

OK or NG

- OK >> GO TO 8.
NG >> Repair or replace as necessary.

8.CHECK SUNLOAD SENSOR CIRCUIT

Check sunload sensor circuit. Refer to [ATC-82. "Sunload Sensor Circuit"](#).

OK or NG

- OK >> GO TO 9.
NG >> Repair or replace as necessary.

9.CHECK INTAKE SENSOR CIRCUIT

Check intake sensor circuit. Refer to [ATC-85. "Intake Sensor Circuit"](#).

OK or NG

- OK >> GO TO 10.
NG >> Repair or replace as necessary.

TROUBLE DIAGNOSIS

< SERVICE INFORMATION >

10. CHECK AIR MIX DOOR MOTORS PBR CIRCUIT

Check air mix door motors PBR circuit. Refer to [ATC-50. "Air Mix Door Motor Circuit"](#).

OK or NG

OK >> If the symptom still exists, perform a complete operational check. Refer to [ATC-40. "Operational Check"](#) and check for other symptoms. Refer to [ATC-25. "How to Perform Trouble Diagnosis for Quick and Accurate Repair"](#). If no other symptom exists replace unified meter and A/C amp. Refer to [ATC-92](#).

NG >> Repair or replace as necessary.

Memory Function

INFOID:000000001721318

SYMPTOM: Memory function does not operate.

INSPECTION FLOW

1. CONFIRM SYMPTOM BY PERFORMING OPERATIONAL CHECK - MEMORY FUNCTION

1. Set the temperature to 32°C (90°F).
2. Press the OFF switch.
3. Turn ignition switch OFF.
4. Start engine.
5. Press the AUTO switch.
6. Confirm that the set temperature remains at previous temperature.
7. Press the OFF switch.

Can the symptom be duplicated?

YES >> GO TO 3.

NO >> GO TO 2.

2. PERFORM COMPLETE OPERATIONAL CHECK

Perform a complete operational check and check for any symptoms. Refer to [ATC-40. "Operational Check"](#).

Can a symptom be duplicated?

YES >> Refer to [ATC-25. "How to Perform Trouble Diagnosis for Quick and Accurate Repair"](#).

NO >> System OK.

3. CHECK FOR SERVICE BULLETINS

Check for any service bulletins.

OK >> GO TO 4.

4. CHECK POWER AND GROUND CIRCUIT

Check main power supply and ground circuit. Refer to [ATC-42. "Power Supply and Ground Circuit for Front Air Control and Unified Meter and A/C Amp"](#).

OK or NG

OK >> 1. Replace the unified meter and A/C amp. Refer to [ATC-92](#)
2. Perform self-diagnosis STEP - 2 to confirm that code No. 20 is displayed. Refer to [ATC-34. "A/C System Self-Diagnosis Function"](#).

NG >> Repair as necessary.

Ambient Sensor Circuit

INFOID:000000001721319

COMPONENT DESCRIPTION

Ambient Sensor

TROUBLE DIAGNOSIS

< SERVICE INFORMATION >

The ambient sensor (1) is attached on the front bumper reinforcement (left side). It detects ambient temperature and converts it into a resistance value which is then input into the unified meter and A/C amp.

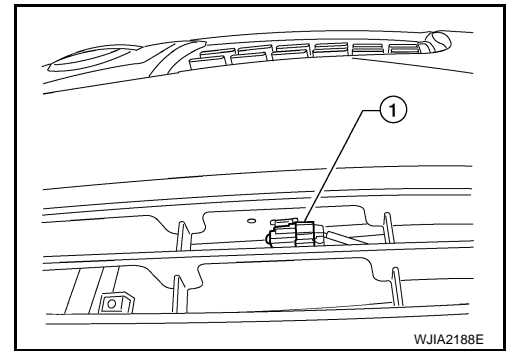

AMBIENT TEMPERATURE INPUT PROCESS

The unified meter and A/C amp. includes a processing circuit for the ambient sensor input. However, when the temperature detected by the ambient sensor increases quickly, the processing circuit retards the unified meter and A/C amp. function. It only allows the unified meter and A/C amp. to recognize an ambient temperature increase of 0.33°C (0.6°F) per 100 seconds.

As an example, consider stopping for a cup of coffee after high speed driving. Although the actual ambient temperature has not changed, the temperature detected by the ambient sensor will increase. This is because the heat from the engine compartment can radiate to the front grille area, location of the ambient sensor.

DIAGNOSTIC PROCEDURE FOR AMBIENT SENSOR

SYMPTOM: Ambient sensor circuit is open or shorted. (21 or - 21 is indicated on unified meter and A/C amp. As a result of conducting Self-diagnosis STEP-2.)

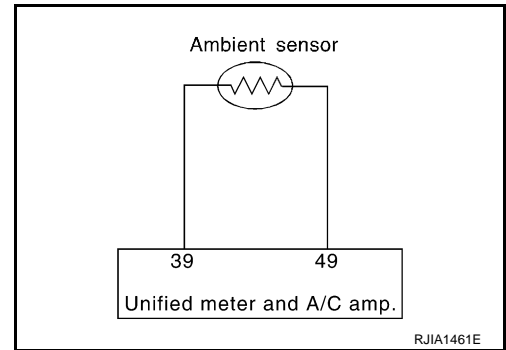

1. CHECK VOLTAGE BETWEEN AMBIENT SENSOR AND GROUND

1. Turn ignition switch OFF.
2. Disconnect ambient sensor connector.
3. Turn ignition switch ON.
4. Check voltage between ambient sensor harness connector E1 terminal 1 and ground.

1 – Ground : Approx. 5V

OK or NG

- OK >> GO TO 2.
NG >> GO TO 4.

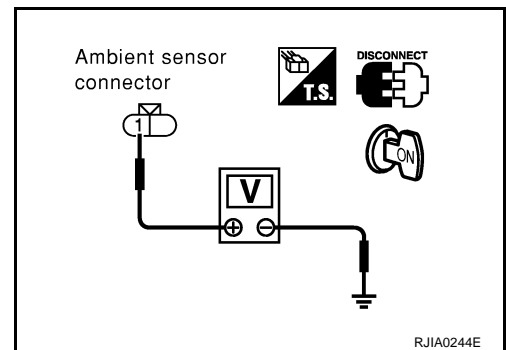

2. CHECK CIRCUIT CONTINUITY BETWEEN AMBIENT SENSOR AND UNIFIED METER AND A/C AMP.

TROUBLE DIAGNOSIS

< SERVICE INFORMATION >

1. Turn ignition switch OFF.
2. Disconnect unified meter and A/C amp. connector.
3. Check continuity between ambient sensor harness connector E1 terminal 2 and unified meter and A/C amp. harness connector M89 terminal 49.

2 – 49 : Continuity should exist.

OK or NG

- OK >> GO TO 3.
NG >> Repair harness or connector.

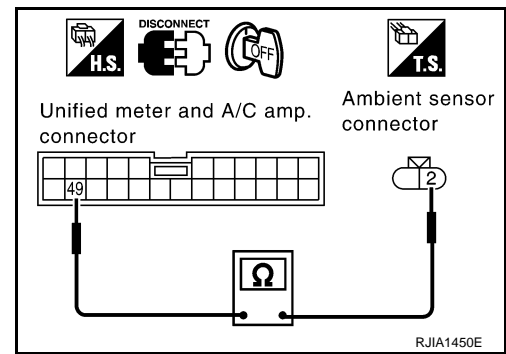

3. CHECK AMBIENT SENSOR

Refer to "Ambient Sensor".

OK or NG

- OK >> 1. Replace unified meter and A/C amp. Refer to [ATC-92](#).
2. GO TO [ATC-34, "A/C System Self-Diagnosis Function"](#) and perform self-diagnosis STEP-2. Confirm that code No. 20 is displayed.
- NG >> 1. Replace ambient sensor. Refer to [ATC-93](#).
2. GO TO [ATC-34, "A/C System Self-Diagnosis Function"](#) and perform self-diagnosis STEP-2. Confirm that code No. 20 is displayed.

4. CHECK CIRCUIT CONTINUITY BETWEEN AMBIENT SENSOR AND UNIFIED METER AND A/C AMP.

1. Turn ignition switch OFF.
2. Disconnect unified meter and A/C amp. connector.
3. Check continuity between ambient sensor harness connector E1 terminal 1 and unified meter and A/C amp. harness connector M89 terminal 39.

1 – 39 : Continuity should exist.

4. Check continuity between ambient sensor harness connector E1 terminal 1 and ground.

1 – Ground : Continuity should not exist.

OK or NG

- OK >> 1. Replace unified meter and A/C amp. Refer to [ATC-92](#).
2. GO TO [ATC-34, "A/C System Self-Diagnosis Function"](#) and perform self-diagnosis STEP -2. Confirm that code No. 20 is displayed.
- NG >> Repair harness or connector.

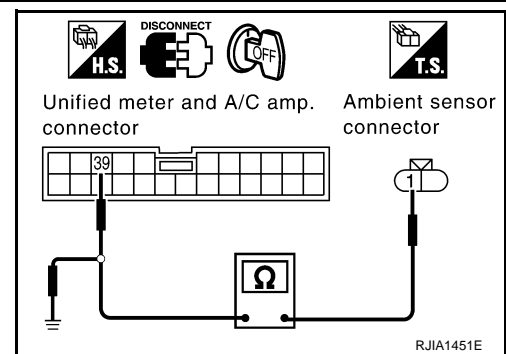

COMPONENT INSPECTION

Ambient Sensor

TROUBLE DIAGNOSIS

< SERVICE INFORMATION >

After disconnecting ambient sensor connector (1), measure resistance between terminals 2 and 1 at sensor harness side, using the table below.

Temperature °C (°F)	Resistance kΩ
-15 (5)	12.73
-10 (14)	9.92
-5 (23)	7.80
0 (32)	6.19
5 (41)	4.95
10 (50)	3.99
15 (59)	3.24
20 (68)	2.65
25 (77)	2.19
30 (86)	1.81
35 (95)	1.51
40 (104)	1.27
45 (113)	1.07

If NG, replace ambient sensor. Refer to [ATC-93](#).

In-vehicle Sensor Circuit

COMPONENT DESCRIPTION

In-vehicle Sensor

The in-vehicle sensor is located on the lower driver instrument panel. It converts variations in temperature of compartment air drawn from the aspirator into a resistance value. It is then input into the unified meter and A/C amp.

Aspirator

The aspirator is located on driver's side of heater and cooling unit assembly. It produces vacuum pressure due to air discharged from the heater and cooling unit assembly, continuously taking compartment air in the aspirator.

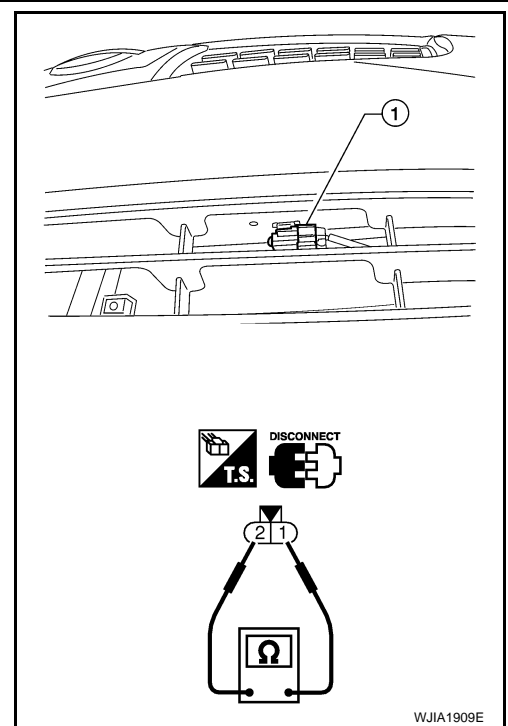

INFOID:000000001721320

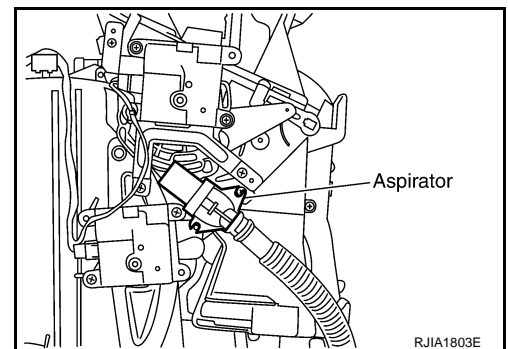
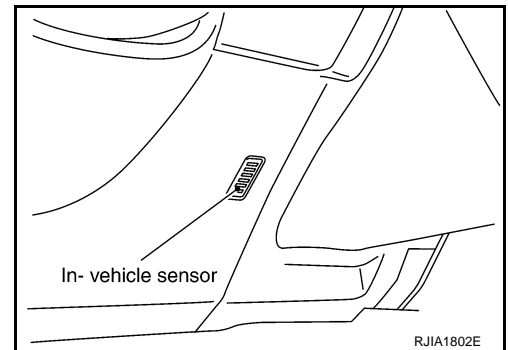

TROUBLE DIAGNOSIS

< SERVICE INFORMATION >

DIAGNOSTIC PROCEDURE FOR IN-VEHICLE SENSOR

SYMPTOM: In-vehicle sensor circuit is open or shorted. (22 or -22 is indicated on unified meter and A/C amp. as a result of conducting Self-diagnosis STEP-2.)

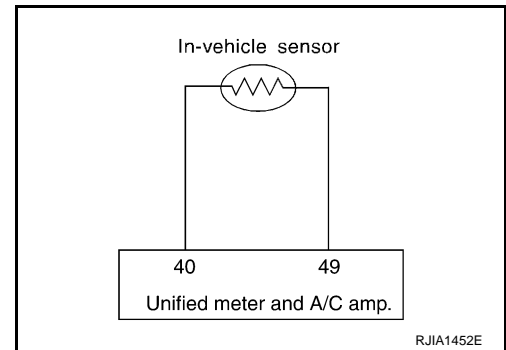
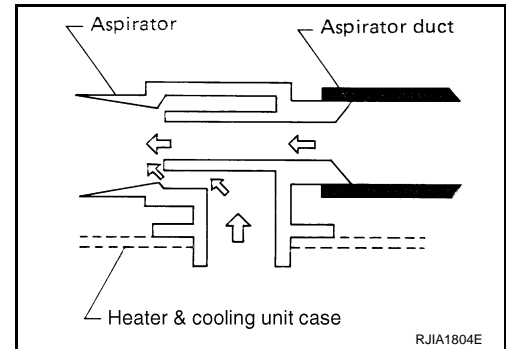

1. CHECK VOLTAGE BETWEEN IN-VEHICLE SENSOR AND GROUND

1. Turn ignition switch OFF.
2. Disconnect in-vehicle sensor connector.
3. Turn ignition switch ON.
4. Check voltage between in-vehicle sensor harness connector M32 terminal 1 and ground.

1 – Ground : Approx. 5V

OK or NG

- OK >> GO TO 2.
NG >> GO TO 4.

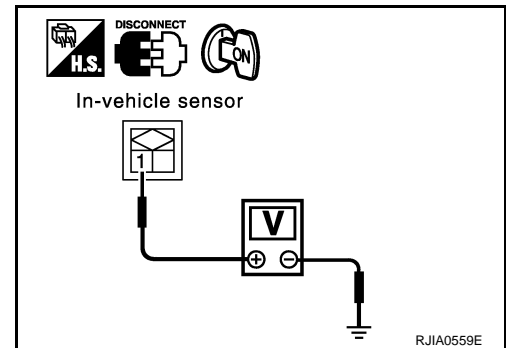

2. CHECK CIRCUIT CONTINUITY BETWEEN IN-VEHICLE SENSOR AND UNIFIED METER AND A/C AMP.

1. Turn ignition switch OFF.
2. Disconnect unified meter and A/C amp. connector.
3. Check continuity between in-vehicle sensor harness connector M32 terminal 2 and unified meter and A/C amp. harness connector M89 terminal 49.

2 – 49 : Continuity should exist.

OK or NG

- OK >> GO TO 3.
NG >> Repair harness or connector.

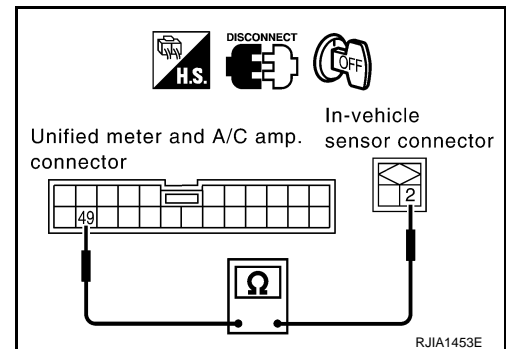

3. CHECK IN-VEHICLE SENSOR

Refer to "In-vehicle Sensor".

OK or NG

- OK >> 1. Replace unified meter and A/C amp. Refer to [ATC-92](#).
2. Go to [ATC-34, "A/C System Self-Diagnosis Function"](#) and perform self-diagnosis STEP 2. Confirm that code No. 20 is displayed.
- NG >> 1. Replace in-vehicle sensor. Refer to [ATC-94](#).
2. Go to [ATC-34, "A/C System Self-Diagnosis Function"](#) and perform self-diagnosis STEP 2. Confirm that code No. 20 is displayed.

TROUBLE DIAGNOSIS

< SERVICE INFORMATION >

4. CHECK CIRCUIT CONTINUITY BETWEEN IN-VEHICLE SENSOR AND UNIFIED METER AND A/C AMP.

1. Turn ignition switch OFF.
2. Disconnect unified meter and A/C amp. connector.
3. Check continuity between in-vehicle sensor harness connector M32 terminal 1 and unified meter and A/C amp. harness connector M89 terminal 40.

1 – 40 : Continuity should exist.

4. Check continuity between in-vehicle sensor harness connector M32 terminal 1 and ground.

1 – Ground : Continuity should not exist.

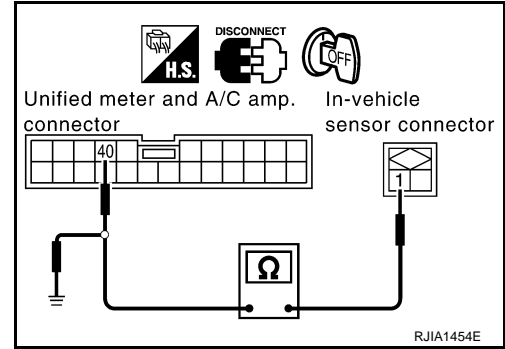

OK or NG

- OK >> 1. Replace unified meter and A/C amp. Refer to [ATC-92](#).
 2. Go to [ATC-34, "A/C System Self-Diagnosis Function"](#) and perform self-diagnosis STEP 2. Confirm that code No. 20 is displayed.

NG >> Repair harness or connector.

COMPONENT INSPECTION

In-vehicle Sensor

After disconnecting in-vehicle sensor connector, measure resistance between terminals 1 and 2 at sensor harness side, using the table below.

Temperature °C (°F)	Resistance kΩ
-15 (5)	12.73
-10 (14)	9.92
-5 (23)	7.80
0 (32)	6.19
5 (41)	4.95
10 (50)	3.99
15 (59)	3.24
20 (68)	2.65
25 (77)	2.19
30 (86)	1.81
35 (95)	1.51
40 (104)	1.27
45 (113)	1.07

If NG, replace in-vehicle sensor. Refer to [ATC-94](#).

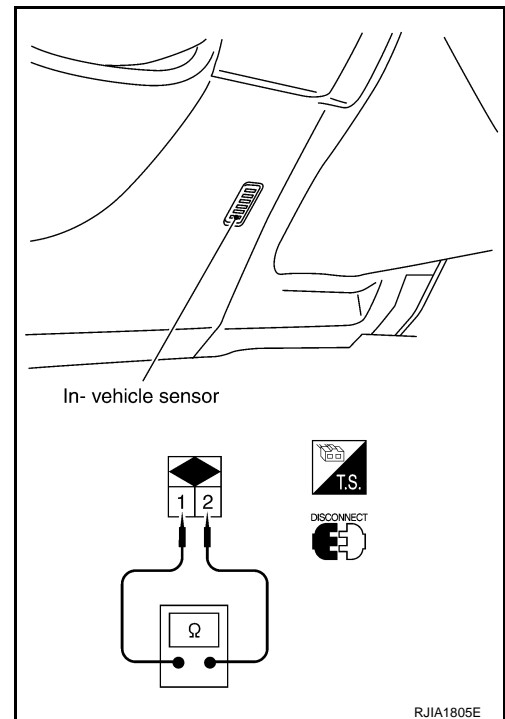

Sunload Sensor Circuit

INFOID:000000001721321

COMPONENT DESCRIPTION

Sunload Sensor

TROUBLE DIAGNOSIS

< SERVICE INFORMATION >

The sunload sensor is located on the passenger side defroster grille. It detects sunload entering through windshield by means of a photo diode. The sensor converts the sunload into a current value which is then input into the unified meter and A/C amp.

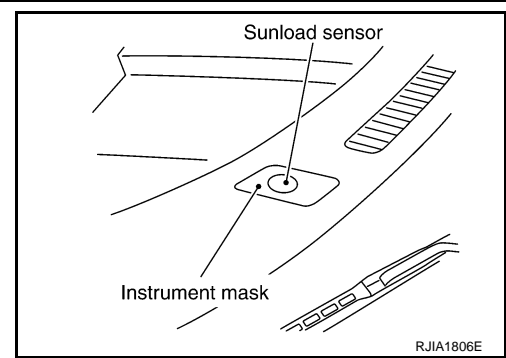

SUNLOAD INPUT PROCESS

The unified meter and A/C amp. also includes a processing circuit which averages the variations in detected sunload over a period of time. This prevents drastic swings in the ATC system operation due to small or quick variations in detected sunload.

For example, consider driving along a road bordered by an occasional group of large trees. The sunload detected by the sunload sensor will vary whenever the trees obstruct the sunlight. The processing circuit averages the detected sunload over a period of time, so that the (insignificant) effect of the trees momentarily obstructing the sunlight does not cause any change in the ATC system operation. On the other hand, shortly after entering a long tunnel, the system will recognize the change in sunload, and the system will react accordingly.

DIAGNOSTIC PROCEDURE FOR SUNLOAD SENSOR

SYMPTOM: Sunload sensor circuit is open or shorted. (25 or -25 is indicated on unified meter and A/C amp. as a result of conducting Self-diagnosis STEP-2.)

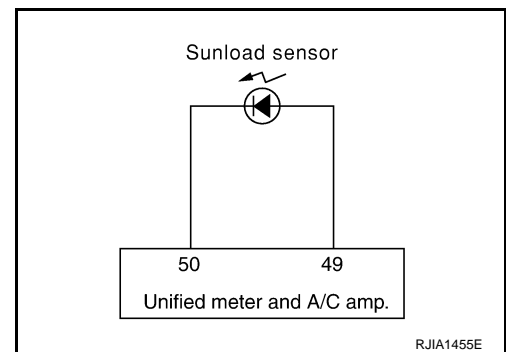

1. CHECK VOLTAGE BETWEEN SUNLOAD SENSOR AND GROUND

1. Turn ignition switch OFF.
2. Disconnect sunload sensor connector.
3. Turn ignition switch ON.
4. Check voltage between sunload sensor harness connector M65 terminal 1 and ground.

1 – Ground : Approx. 5V

OK or NG

- OK >> GO TO 2.
- NG >> GO TO 4.

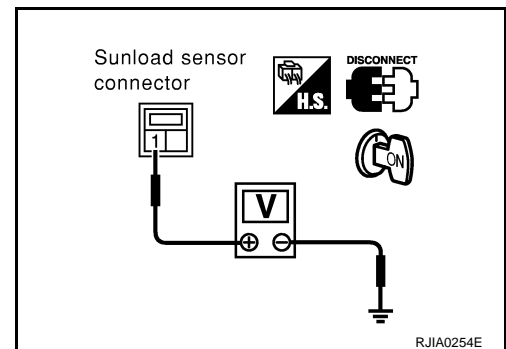

2. CHECK CIRCUIT CONTINUITY BETWEEN SUNLOAD SENSOR AND UNIFIED METER AND A/C AMP.

TROUBLE DIAGNOSIS

< SERVICE INFORMATION >

1. Turn ignition switch OFF.
2. Disconnect unified meter and A/C amp. connector.
3. Check continuity between sunload sensor harness connector M65 terminal 2 and unified meter and A/C amp. harness connector M89 terminal 49.

2 – 49 : Continuity should exist.

OK or NG

- OK >> GO TO 3.
NG >> Repair harness or connector.

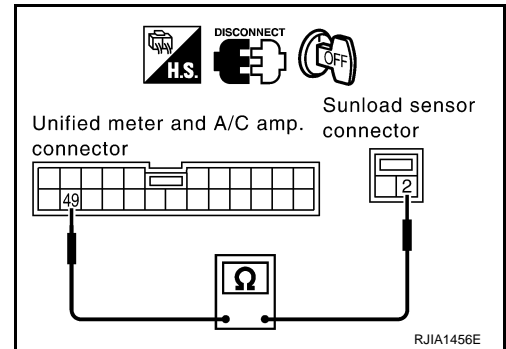

3. CHECK SUNLOAD SENSOR

Refer to "Sunload Sensor".

OK or NG

- OK >> 1. Replace unified meter and A/C amp. Refer to [ATC-92](#).
2. Go to [ATC-34, "A/C System Self-Diagnosis Function"](#) and perform self-diagnosis STEP-2. Confirm that code No. 20 is displayed.
- NG >> 1. Replace sunload sensor. Refer to [ATC-95](#).
2. Go to [ATC-34, "A/C System Self-Diagnosis Function"](#) and perform self-diagnosis STEP-2. Confirm that code No. 20 is displayed.

4. CHECK CIRCUIT CONTINUITY BETWEEN SUNLOAD SENSOR AND UNIFIED METER AND A/C AMP.

1. Turn ignition switch OFF.
2. Disconnect unified meter and A/C amp. connector.
3. Check continuity between sunload sensor harness connector M65 terminal 1 and display and unified meter and A/C amp. harness connector M89 terminal 50.

1 – 50 : Continuity should exist.

4. Check continuity between sunload sensor harness connector M65 terminal 1 and ground.

1 – Ground : Continuity should not exist.

OK or NG

- OK >> 1. Replace unified meter and A/C amp. Refer to [ATC-92](#).
2. Go to [ATC-34, "A/C System Self-Diagnosis Function"](#) and perform self-diagnosis STEP-2. Confirm that code No. 20 is displayed.
- NG >> Repair harness or connector.

COMPONENT INSPECTION

Sunload Sensor

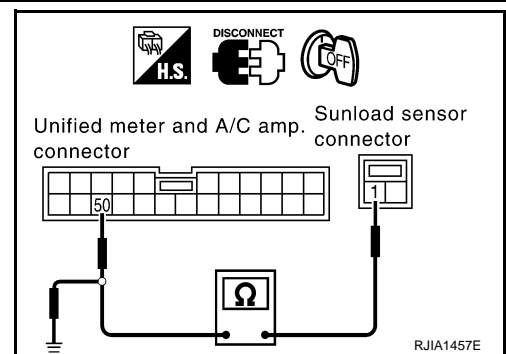

TROUBLE DIAGNOSIS

< SERVICE INFORMATION >

Measure voltage between unified meter and A/C amp. harness connector M89 terminal 50 and ground.
 If NG, replace unified meter and A/C amp. Refer to [ATC-92](#).

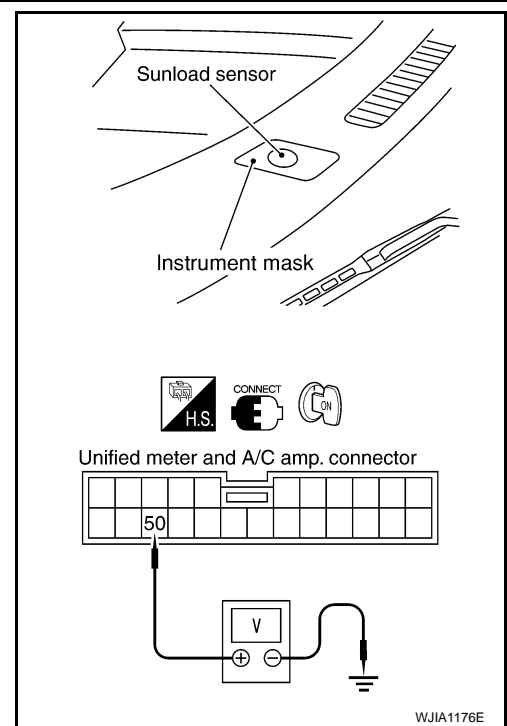

- When checking sunload sensor, select a place where sun shines directly on it.

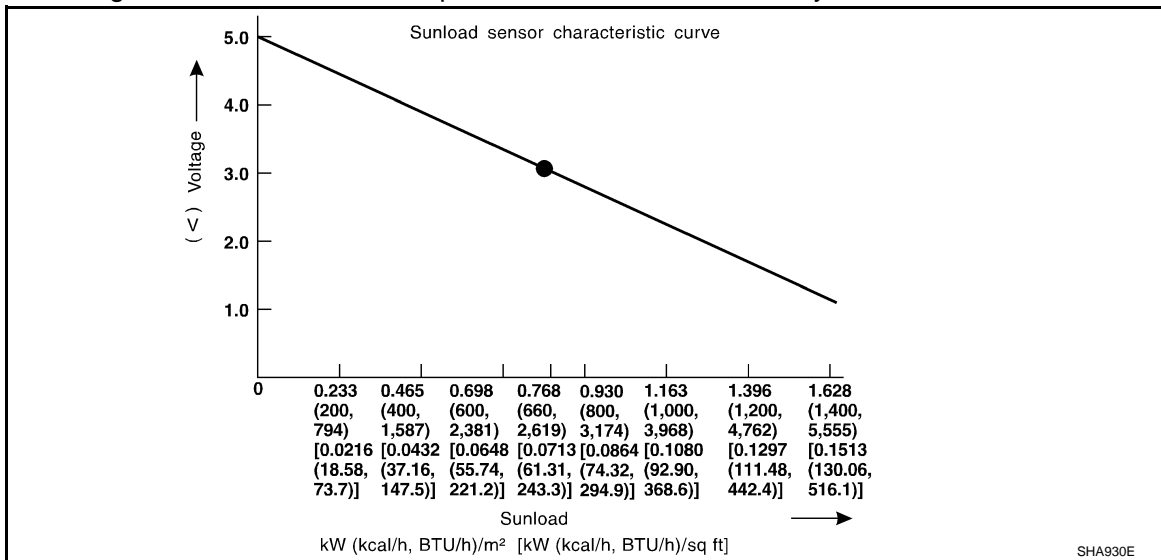

Intake Sensor Circuit

INFOID:000000001721322

COMPONENT DESCRIPTION

Intake Sensor

The intake sensor is located in the heater and cooling unit assembly on the evaporator. It converts temperature of air after it passes through the evaporator into a resistance value which is then input to the unified meter and A/C amp.

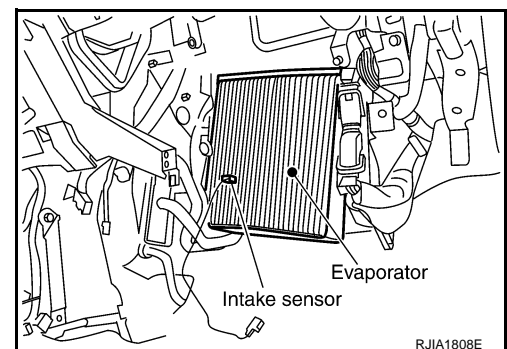

TROUBLE DIAGNOSIS

< SERVICE INFORMATION >

DIAGNOSTIC PROCEDURE FOR INTAKE SENSOR

SYMPTOM: Intake sensor circuit is open or shorted. (24 or -24 is indicated on unified meter and A/C amp. as a result of conducting Self-diagnosis STEP 2.)

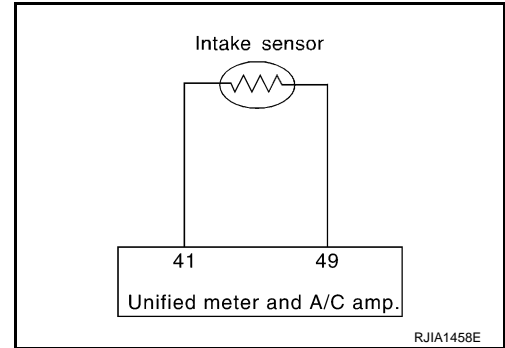

1. CHECK VOLTAGE BETWEEN INTAKE SENSOR AND GROUND

1. Turn ignition switch OFF.
2. Disconnect intake sensor connector.
3. Turn ignition switch ON.
4. Check voltage between intake sensor harness connector M33 terminal 1 and ground.

1 – Ground : Approx. 5V

OK or NG

- OK >> GO TO 2.
NG >> GO TO 4.

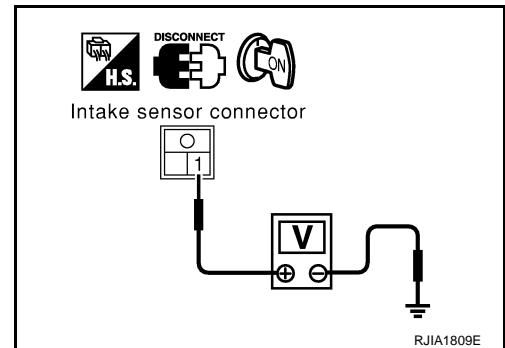

2. CHECK CIRCUIT CONTINUITY BETWEEN INTAKE SENSOR AND UNIFIED METER AND A/C AMP.

1. Turn ignition switch OFF.
2. Disconnect unified meter and A/C amp. connector.
3. Check continuity between intake sensor harness connector M33 terminal 2 and unified meter and A/C amp. harness connector M89 terminal 49.

2 – 49 : Continuity should exist.

OK or NG

- OK >> GO TO 3.
NG >> Repair harness or connector.

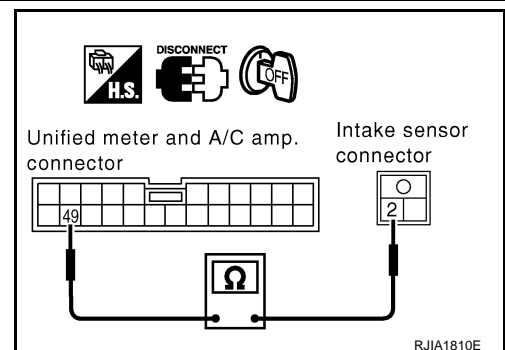

3. CHECK INTAKE SENSOR

Refer to "Intake Sensor".

OK or NG

- OK >> 1. Replace unified meter and A/C amp. Refer to [ATC-92](#).
2. Go to [ATC-34, "A/C System Self-Diagnosis Function"](#) and perform self-diagnosis STEP 2. Confirm that code No. 20 is displayed.
- NG >> 1. Replace intake sensor. Refer to [ATC-96](#).
2. Go to [ATC-34, "A/C System Self-Diagnosis Function"](#) and perform self-diagnosis STEP 2. Confirm that code No. 20 is displayed.

4. CHECK CIRCUIT CONTINUITY BETWEEN INTAKE SENSOR AND UNIFIED METER AND A/C AMP.

TROUBLE DIAGNOSIS

< SERVICE INFORMATION >

1. Turn ignition switch OFF.
2. Disconnect unified meter and A/C amp. connector.
3. Check continuity between intake sensor harness connector M33 terminal 1 and unified meter and A/C amp. harness connector M89 terminal 41.

1 – 41 : Continuity should exist.

4. Check continuity between intake sensor harness connector M33 terminal 1 and ground.

1 – Ground : Continuity should not exist.

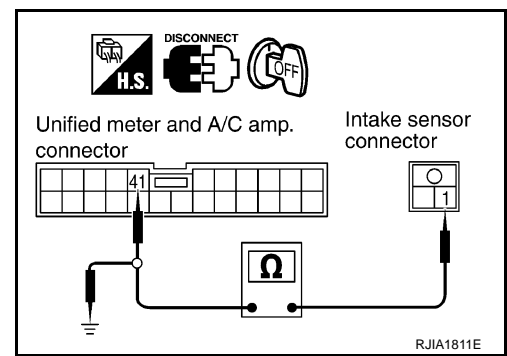

OK or NG

- OK >> 1. Replace unified meter and A/C amp. Refer to [ATC-92](#).
 2. Go to [ATC-34, "A/C System Self-Diagnosis Function"](#) and perform self-diagnosis STEP 2. Confirm that code No. 20 is displayed.
- NG >> Repair harness or connector.

COMPONENT INSPECTION

Intake Sensor

After disconnecting intake sensor connector, measure resistance between terminals 1 and 2 at sensor harness side, using the table below.

Temperature °C (°F)	Resistance kΩ
-15 (5)	18.63
-10 (14)	14.14
-5 (23)	10.85
0 (32)	8.40
5 (41)	6.57
10 (50)	5.18
15 (59)	4.12
20 (68)	3.30
25 (77)	2.66
30 (86)	2.16
35 (95)	1.77
40 (104)	1.46
45 (113)	1.21

If NG, replace intake sensor. Refer to [ATC-96](#).

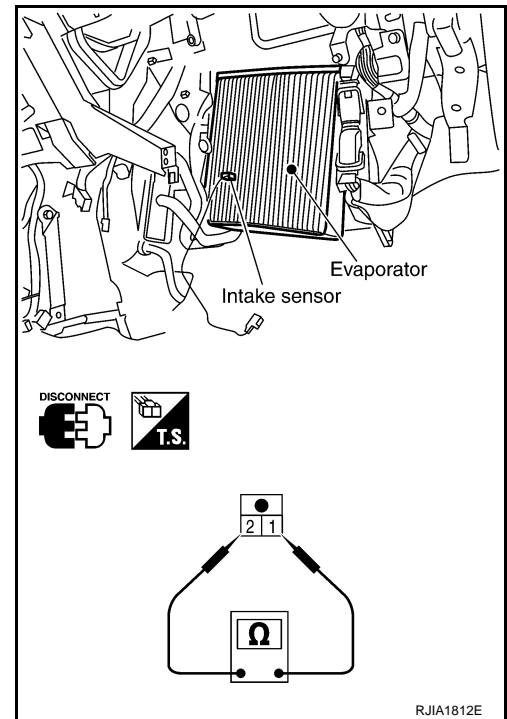

Multiplex Communication Circuit

INFOID:000000001721323

DIAGNOSIS PROCEDURE FOR MULTIPLEX COMMUNICATION

SYMPTOM: A/C system cannot be controlled.

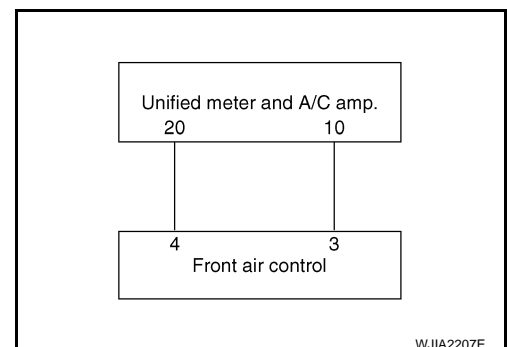

TROUBLE DIAGNOSIS

< SERVICE INFORMATION >

1. CHECK FOR UNIFIED METER AND A/C AMP. OUTPUT

1. Turn ignition switch ON.
2. Check multiplex communication signal between unified meter and A/C amp. harness connector M49 terminal 10 and ground using an oscilloscope.

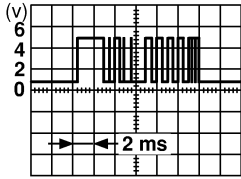
Terminal		(-)	Voltage
(+)	Terminal No.		
Unified meter and A/C amp. connector			
M49	10	Ground	 <p style="text-align: right;">RJIA0212E</p>

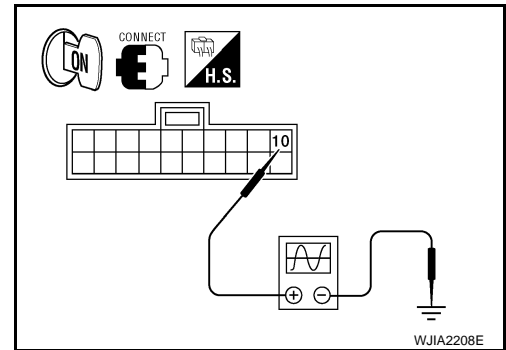

OK or NG

- OK >> GO TO 3.
 NG >> GO TO 2.

2. CHECK CIRCUIT CONTINUITY BETWEEN FRONT AIR CONTROL AND UNIFIED METER AND A/C AMP.

1. Turn ignition switch OFF.
2. Disconnect front air control connector and unified meter and A/C amp. connector.
3. Check continuity between front air control harness connector M201 (B) terminal 3 and unified meter and A/C amp. harness connector M49 (A) terminal 10.

3 – 10 : Continuity should exist.

OK or NG

- OK >> Replace unified meter and A/C amp. Refer to [ATC-92](#).
 NG >> Repair harness or connector.

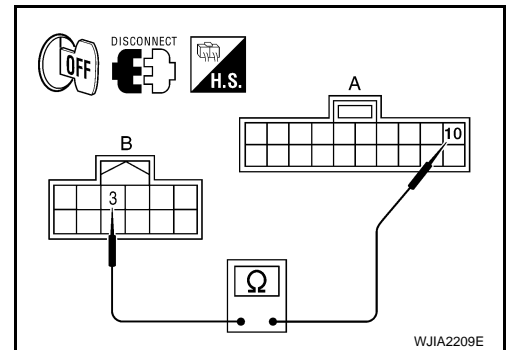

3. CHECK FOR UNIFIED METER AND A/C AMP. INPUT

Confirm multiplex communication signal between unified meter and A/C amp. harness connector M49 terminal 20 and ground using an oscilloscope.

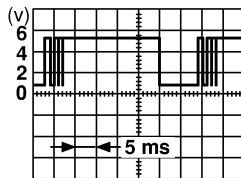
Terminal		(-)	Voltage
(+)	Terminal No.		
Unified meter and A/C amp. connector			
M49	20	Ground	 <p style="text-align: right;">RJIA0213E</p>

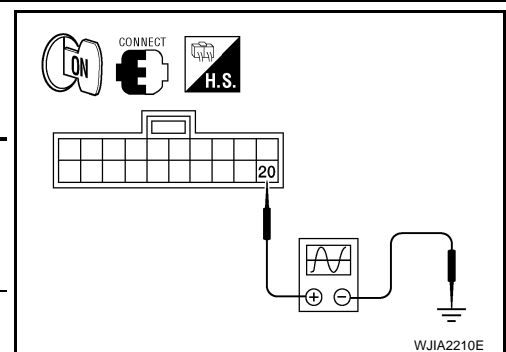

OK or NG

- OK >> Replace unified meter and A/C amp. Refer to [ATC-92](#).
 NG >> GO TO 4.

TROUBLE DIAGNOSIS

< SERVICE INFORMATION >

4. CHECK CIRCUIT CONTINUITY BETWEEN FRONT AIR CONTROL AND UNIFIED METER AND A/C AMP.

1. Turn ignition switch OFF.
2. Disconnect front air control connector and unified meter A/C amp. connector.
3. Check continuity between front air control harness connector M201 (B) terminal 4 and unified meter and A/C amp. harness connector M49 (A) terminal 20.

4 – 20 : Continuity should exist.

OK or NG

- OK >> Replace front air control. Refer to [IP-13. "Center Stack Assembly"](#).
- NG >> Repair harness or connector.

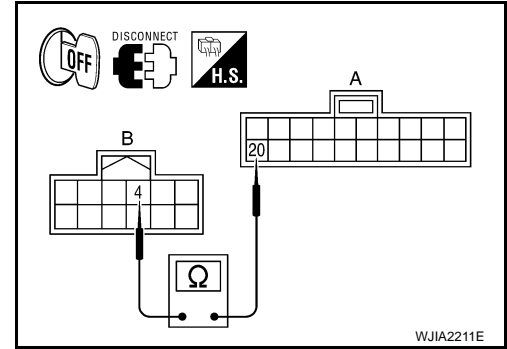

A/C Display (without NAVI)

INFOID:000000001721324

DIAGNOSIS PROCEDURE FOR A/C DISPLAY

SYMPTOM: A/C display inoperative.

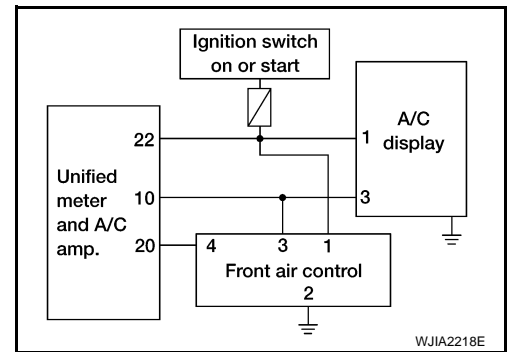

1. CHECK FOR UNIFIED METER AND A/C AMP. OUTPUT

1. Disconnect the front air control.
2. Turn ignition switch ON.
3. Check multiplex communication signal between unified meter and A/C amp. harness connector M49 terminal 10 and ground using an oscilloscope.

Terminal		(-)	Voltage
(+)	Terminal No.		
Unified meter and A/C amp. connector		(-)	
M49	10	Ground	<p style="text-align: right;">RJIA0212E</p>

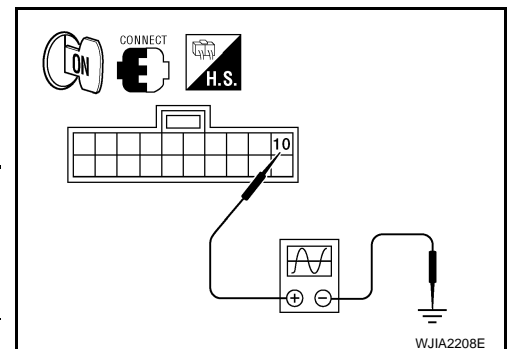

OK or NG

- OK >> GO TO 3.
- NG >> GO TO 2.

2. CHECK CIRCUIT CONTINUITY BETWEEN A/C DISPLAY AND UNIFIED METER AND A/C AMP.

A
B
C
D
E
F
G
H
I
K
L
M
N
O
P

ATC

TROUBLE DIAGNOSIS

< SERVICE INFORMATION >

1. Turn ignition switch OFF.
2. Disconnect A/C display connector and unified meter and A/C amp. connector.
3. Check continuity between A/C display harness connector M118 (B) terminal 3 and unified meter and A/C amp. harness connector M49 (A) terminal 10.

3 – 10 : Continuity should exist.

OK or NG

- OK >> Replace unified meter and A/C amp. Refer to [ATC-92](#).
- NG >> Repair harness or connector.

3. CHECK POWER SUPPLY CIRCUIT FOR A/C DISPLAY

1. Turn ignition switch OFF.
2. Disconnect A/C display.
3. Turn ignition switch ON.
4. Check voltage between A/C display harness connector M118 terminal 1 and ground.

Terminals		Ignition switch position		
(+)		(-)	OFF	ON
A/C display	Terminal No.		Approx. 0V	Battery voltage
M118	1	Ground	Approx. 0V	Battery voltage

OK or NG

- OK >> GO TO 4.
- NG >> Repair harness or connector as necessary

4. CHECK GROUND CIRCUIT FOR A/C DISPLAY

1. Turn ignition OFF.
2. Check continuity between A/C display harness connector M118 terminal 7 and ground.

7 – Ground : Continuity should exist.

OK or NG

- OK >> Replace A/C display. Refer to [IP-13, "Center Stack Assembly"](#)
- NG >> Repair harness or connector.

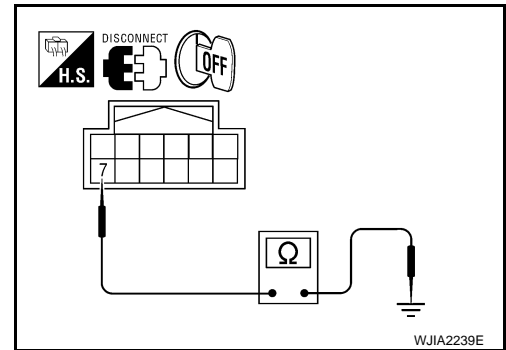
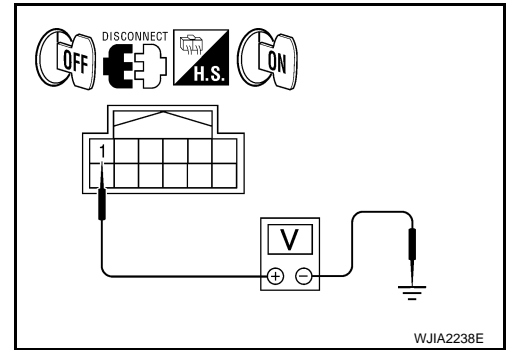
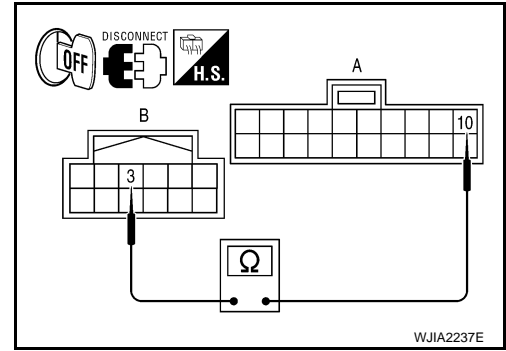

Front Air Control Self - Diagnosis

INFOID:000000001721325

DIAGNOSIS PROCEDURE FOR FRONT AIR CONTROL

SYMPTOM: A/C system cannot be controlled.

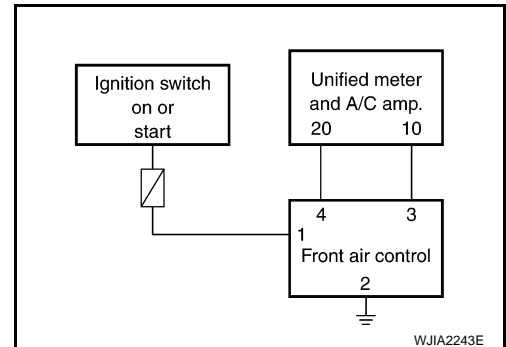

TROUBLE DIAGNOSIS

< SERVICE INFORMATION >

1. ENTER SELF-DIAGNOSIS FOR FRONT AIR CONTROL

1. Start engine.
2. Within 10 seconds after starting the engine, press and hold the MODE switch and the DUAL switch for more than three seconds.
3. Within 10 seconds after turning the ignition switch ON, press and hold the MODE switch and the DUAL switch for more than three seconds. All LED's on the front air control will illuminate.

>> GO TO 2.

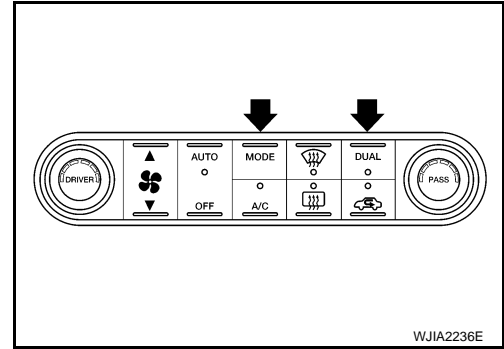

2. CHECK EACH SWITCH AND CONTROL DIAL ON THE FRONT AIR CONTROL

1. While monitoring the LEDs on the front air control press each switch twice. All LEDs will toggle ON or OFF each time it's pushed.
2. While monitoring the LEDs on the front air control, rotate the temperature control dials (driver and pass). All LEDs will toggle ON or OFF each time the dial is rotated.

Do all LEDS flash ON and then OFF?

- OK >> Inspection End.
NG >> Replace front air control. Refer to [IP-13, "Center Stack Assembly"](#)

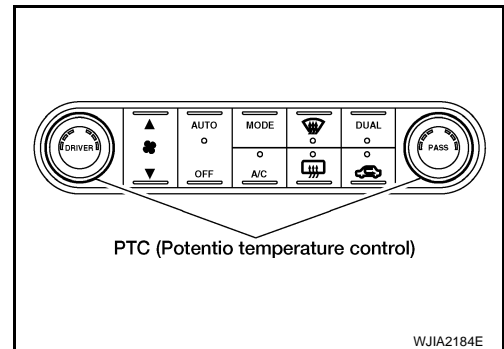

A
B
C
D
E
F
G
H
I
K
L
M
N
O
P

ATC

UNIFIED METER AND A/C AMP.

< SERVICE INFORMATION >

UNIFIED METER AND A/C AMP.

Removal and Installation

INFOID:000000001721326

REMOVAL

1. Remove the shift knob.
2. Remove the shift bezel.
3. Remove cluster lid C. Refer to [JP-12, "Cluster Lid C"](#).
4. Remove cluster lid D. Refer to [JP-12, "Cluster Lid D"](#).
5. Remove the center stack.
6. Remove the bolts securing the rear of the unified meter and A/C auto amp.
7. Remove the bolts on either side of display screen.
8. Gently spread the top of the bracket and remove the unified meter and A/C auto amp.

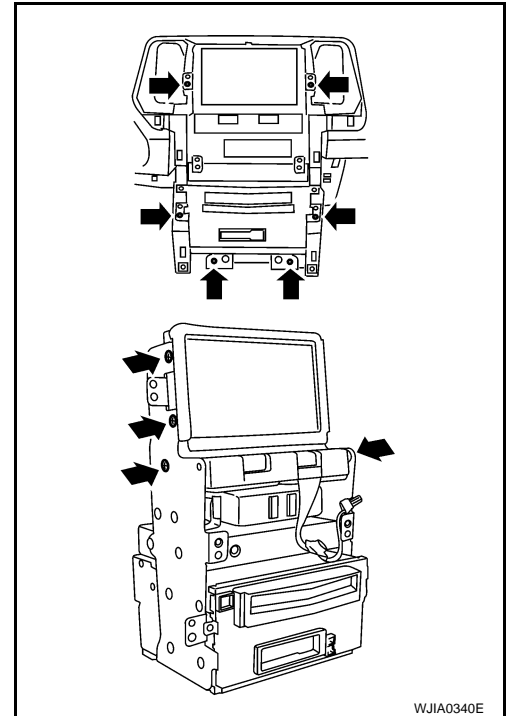

INSTALLATION

Installation is in the reverse order of removal.

AMBIENT SENSOR

< SERVICE INFORMATION >

AMBIENT SENSOR

Removal and Installation

INFOID:000000001721327

REMOVAL

1. Disconnect the ambient sensor connector.
2. Release the ambient sensor (1) from the front bumper reinforcement (2).

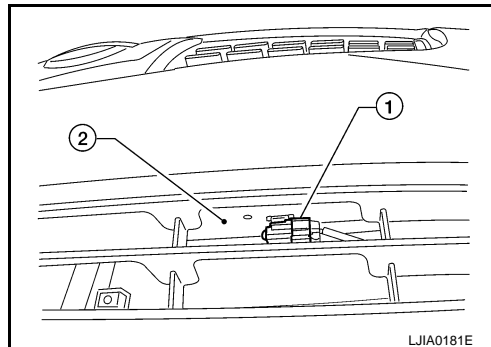

3. Remove the ambient sensor.

INSTALLATION

Installation is in the reverse order of removal.

A
B
C
D
E
F
G
H
I
K
L
M
N
O
P

ATC

IN-VEHICLE SENSOR

< SERVICE INFORMATION >

IN-VEHICLE SENSOR

Removal and Installation

INFOID:000000001721328

REMOVAL

1. Remove the lower driver instrument panel. Refer to [IP-14. "Lower Driver Instrument Panel"](#).
2. Remove the in-vehicle sensor screw.
3. Remove the in-vehicle sensor.

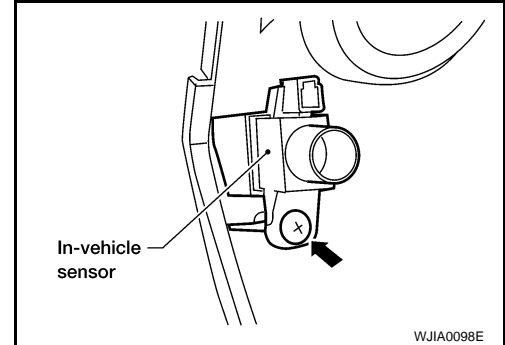

INSTALLATION

Installation is in the reverse order of removal.

SUNLOAD SENSOR

< SERVICE INFORMATION >

SUNLOAD SENSOR

Removal and Installation

INFOID:000000001721329

REMOVAL

1. Remove the instrument mask.
2. Release the sunload sensor tabs and then remove the sunload sensor from the instrument mask.
3. Disconnect the sunload sensor connector.
4. Remove the sunload sensor.

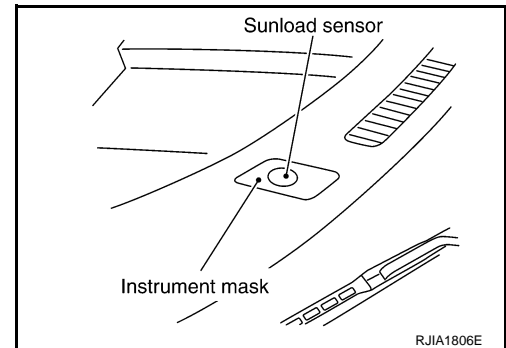

INSTALLATION

Installation is in the reverse order of removal.

A

B

C

D

E

F

G

H

I

ATC

K

L

M

N

O

P

INTAKE SENSOR

< SERVICE INFORMATION >

INTAKE SENSOR

Removal and Installation

INFOID:000000001721330

REMOVAL

1. Remove the evaporator. Refer to [ATC-117, "Removal and Installation for Evaporator"](#).
2. Remove the intake sensor clip.
CAUTION:
Be careful not to damage the evaporator core surface.
3. Remove the intake sensor.

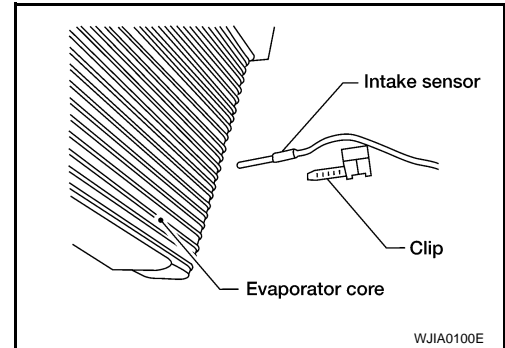

INSTALLATION

Installation is in the reverse order of removal.

BLOWER UNIT

< SERVICE INFORMATION >

BLOWER UNIT

Removal and Installation

INFOID:000000001721331

REMOVAL

1. Remove the glove box assembly. Refer to [IP-15, "Glove Box Assembly and Housing"](#).
2. Remove the center console side cover. Refer to [IP-17, "Front Center Console"](#).
3. Disconnect the battery negative terminal.
4. Remove the ECM.
5. Disconnect the blower motor, intake door motor, and fan control amp. connector.
6. Disconnect the main harness from the top of the blower unit.
7. Remove the two bolts and one screw from the blower unit as shown.
8. Remove the blower unit.

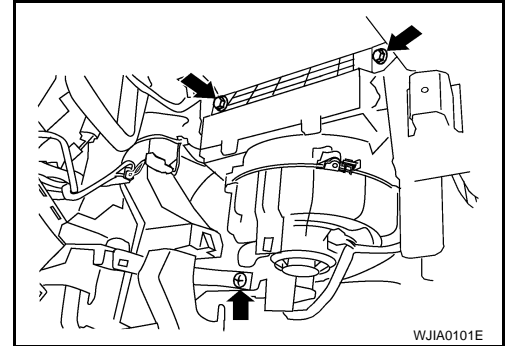

INSTALLATION

Installation is in the reverse order of removal.

A

B

C

D

E

F

G

H

I

ATC

K

L

M

N

O

P

BLOWER MOTOR

< SERVICE INFORMATION >

BLOWER MOTOR

Removal and Installation

INFOID:000000001721332

REMOVAL

1. Remove the blower unit. Refer to [ATC-97. "Removal and Installation"](#).
2. Release the eight tabs attaching the blower motor to the blower unit case.
3. Remove the blower motor.

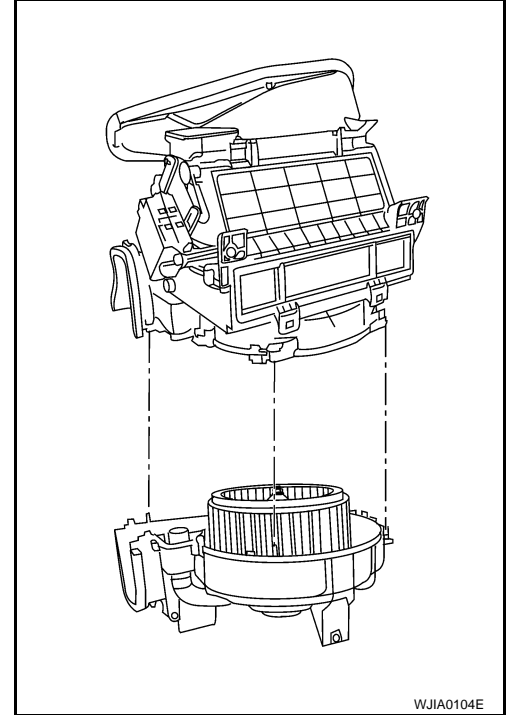

INSTALLATION

Installation is in the reverse order of removal.

INTAKE DOOR MOTOR

< SERVICE INFORMATION >

INTAKE DOOR MOTOR

Removal and Installation

INFOID:000000001721333

REMOVAL

1. Remove the blower unit. Refer to [ATC-97. "Removal and Installation"](#).
2. Remove the two intake door motor screws.
3. Remove the intake door motor from the blower unit.

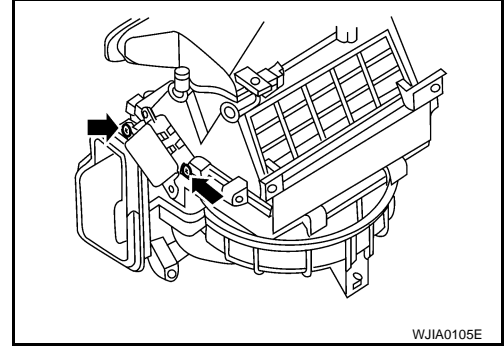

INSTALLATION

Installation is in the reverse order of removal.

A
B
C
D
E
F
G
H
I
K
L
M
N
O
P

ATC

IN-CABIN MICROFILTER

< SERVICE INFORMATION >

IN-CABIN MICROFILTER

Removal and Installation

INFOID:000000001721334

FUNCTION

The air inside the passenger compartment is kept clean in either the recirculation or fresh mode by the in-cabin microfilter in the blower unit.

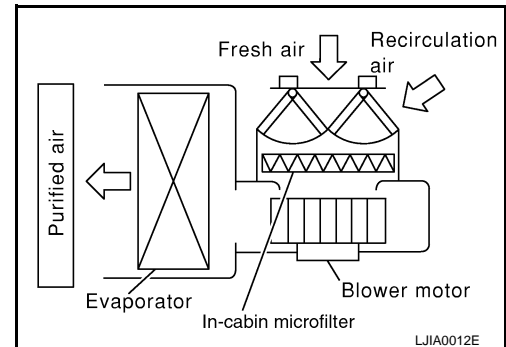

REPLACEMENT TIMING

Replace the in-cabin microfilter by following the applicable maintenance schedule. Refer to [MA-7, "Schedule 1"](#) and [MA-9, "Schedule 2"](#). The in-cabin microfilter caution label is affixed inside the glove box.

REPLACEMENT PROCEDURES

1. Remove the glove box pins. Refer to [IP-15, "Glove Box Assembly and Housing"](#).
2. Press in the sides of the glove box door to release the glove box door from the glove box housing.
3. Disconnect the glove box damper cord to remove the glove box door.
4. Disengage the two filter cover tabs to remove the filter cover.
5. Remove the in-cabin microfilter from the blower unit.
6. Install the new in-cabin microfilter into the blower unit.

CAUTION:

- Insert the new filter with the "UP" arrow in the correct orientation.
 - Insert the new filter with the "UP" arrow side of the filter facing the rear of the vehicle.
7. Install the filter cover on the blower unit.
 8. Connect the glove box damper cord to the glove box door.
 9. Press in the sides of the glove box door to install the glove box door into the glove box housing.
 10. Install the glove box pins.

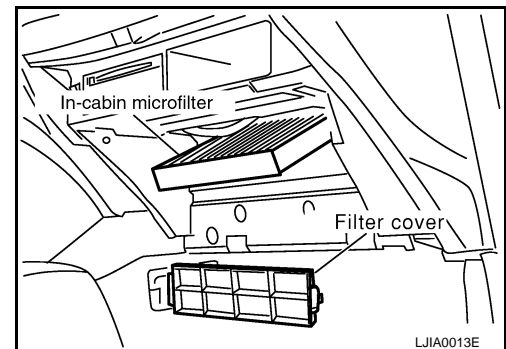

HEATER & COOLING UNIT ASSEMBLY

< SERVICE INFORMATION >

HEATER & COOLING UNIT ASSEMBLY

Removal and Installation

INFOID:000000001721335

REMOVAL

1. Discharge the refrigerant from the A/C system. Refer to [ATC-109. "HFC-134a \(R-134a\) Service Procedure"](#)
2. Drain the coolant from the cooling system. Refer to [MA-15. "Changing Engine Coolant"](#).
3. Disconnect the heater hoses from the heater core pipes.
4. Disconnect the refrigerant lines from the evaporator.
5. Remove the instrument panel. Refer to [IP-10](#).
6. Remove the blower unit. Refer to [ATC-97](#).
7. Disconnect the mode door motor and the air mix door motor connectors.
8. Remove the heater and cooling unit.

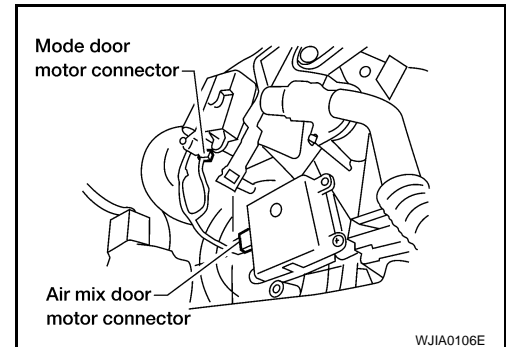

INSTALLATION

Installation is in the reverse order of removal.

- Fill the radiator with coolant. Refer to [MA-15. "Changing Engine Coolant"](#).
- Recharge the A/C system. Refer to [ATC-109. "HFC-134a \(R-134a\) Service Procedure"](#).

A
B
C
D
E
F
G
H
I
K
L
M
N
O
P

ATC

HEATER CORE

< SERVICE INFORMATION >

HEATER CORE

Removal and Installation

INFOID:000000001721336

REMOVAL

1. Remove the heater and cooling unit. Refer to [ATC-101](#).
2. Remove the heater core pipe support screws and then remove the heater core pipe support.

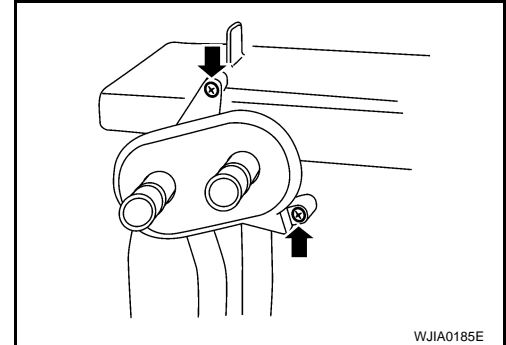

3. Remove the air mix door motor (passenger side).

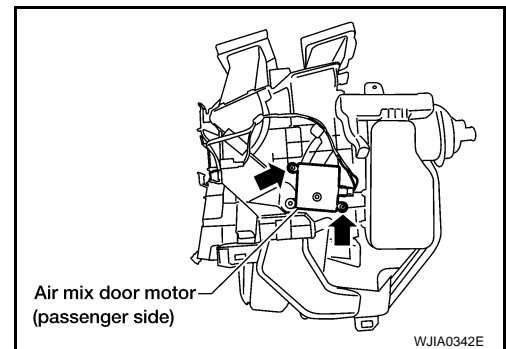

4. Remove the heater core cover screws and then remove the heater core cover.

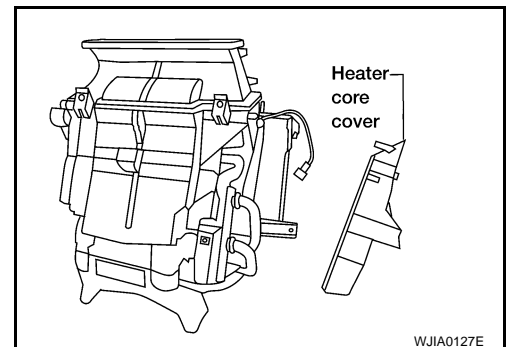

5. Remove the heater core.

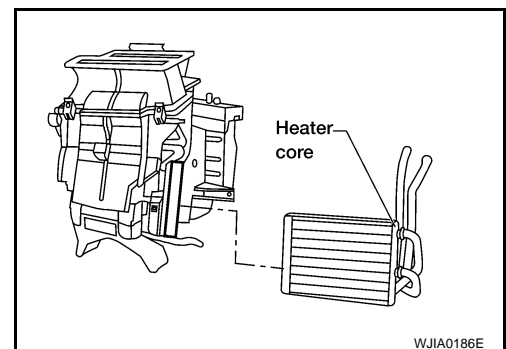

INSTALLATION

Installation is in the reverse order of removal.

MODE DOOR MOTOR

< SERVICE INFORMATION >

MODE DOOR MOTOR

Removal and Installation

INFOID:000000001721337

REMOVAL

1. Remove the lower driver instrument panel. Refer to [IP-14, "Lower Driver Instrument Panel"](#).
2. Disconnect the mode door motor connector.
3. Remove the mode door motor screws and then remove the mode door motor.

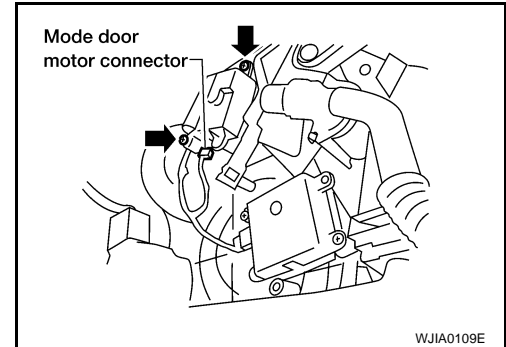

INSTALLATION

Installation is in the reverse order of removal.

A
B
C
D
E
F
G
H
I
K
L
M
N
O
P

ATC

AIR MIX DOOR MOTOR

< SERVICE INFORMATION >

AIR MIX DOOR MOTOR

Removal and Installation

INFOID:000000001721338

DRIVER SIDE AIR MIX DOOR MOTOR

Removal

1. Remove the lower driver instrument panel. Refer to [IP-14, "Lower Driver Instrument Panel"](#).
2. Disconnect the driver side air mix door motor connector.
3. Remove the driver side air mix door motor screws.
4. Remove the driver side air mix door motor.

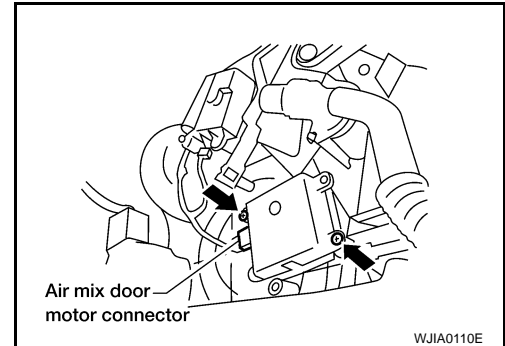

Installation

Installation is in the reverse order of removal.

PASSENGER SIDE AIR MIX DOOR MOTOR

Removal

1. Remove the glove box assembly. Refer to [IP-15, "Glove Box Assembly and Housing"](#).
2. Disconnect the passenger side air mix door motor connector.
3. Remove the passenger side air mix door motor screws.
4. Remove the passenger side air mix door motor.

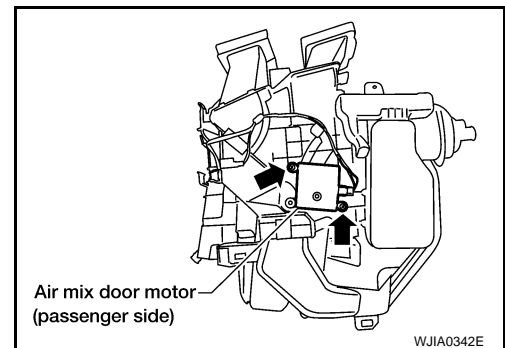

Installation

Installation is in the reverse order of removal.

FAN CONTROL AMPLIFIER

< SERVICE INFORMATION >

FAN CONTROL AMPLIFIER

Removal and Installation

INFOID:000000001721339

REMOVAL

1. Disconnect the fan control amplifier. connector.
2. Remove the screws from the fan control amplifier.
3. Remove the fan control amplifier.

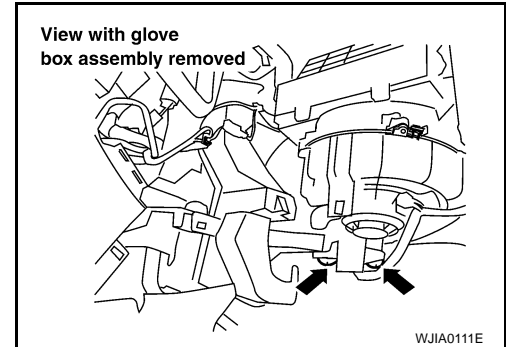

INSTALLATION

Installation is in the reverse order of removal.

A
B
C
D
E
F
G
H
I
K
L
M
N
O
P

ATC

DUCTS AND GRILLES

< SERVICE INFORMATION >

DUCTS AND GRILLES

Removal and Installation

INFOID:000000001721340

Ventilator Duct, Defroster Nozzle and Defroster Ducts

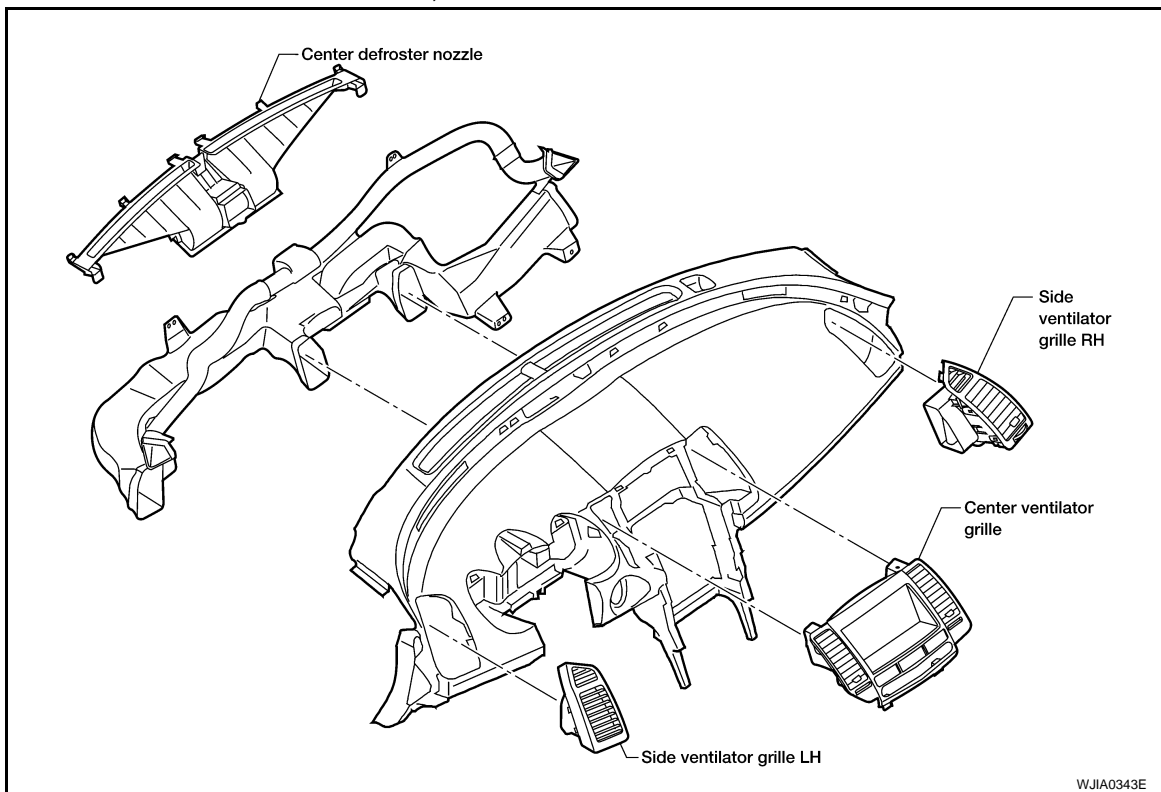

CENTER VENTILATOR GRILLE

Removal

1. Remove the shift knob.
2. Remove the shift bezel.
3. Remove cluster lid C. Refer to [IP-12, "Cluster Lid C"](#).
4. Remove cluster lid D. Refer to [IP-12, "Cluster Lid D"](#).
5. Release the tabs to remove each of the two center ventilator grilles from cluster lid D.

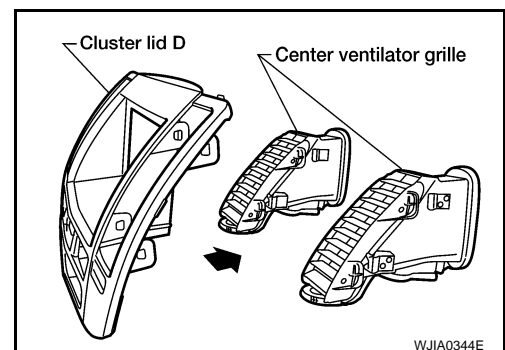

Installation

Installation is in the reverse order of removal.

SIDE VENTILATOR GRILLE LH

Removal

1. Remove the instrument panel. Refer to [IP-10, "Instrument Panel"](#).

DUCTS AND GRILLES

< SERVICE INFORMATION >

2. Release the tabs to remove side ventilator grille LH.

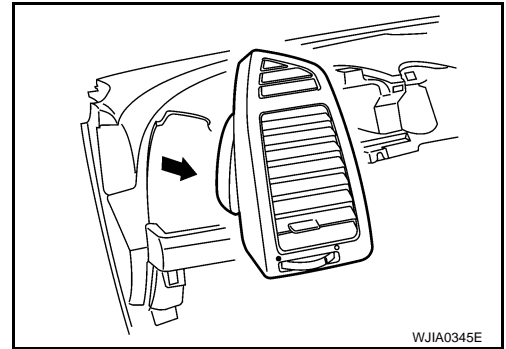

Installation

Installation is in the reverse order of removal.

SIDE VENTILATOR GRILLE RH

Removal

1. Remove the instrument panel. Refer to [IP-10. "Instrument Panel"](#).
2. Release the tabs to remove side ventilator grille RH.

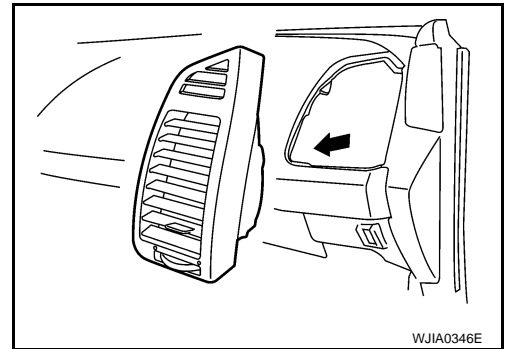

Installation

Installation is in the reverse order of removal.

FLOOR DUCT

Removal

1. Remove the carpet. Refer to [EI-36](#).
2. Remove the two clips.
3. Remove the floor ducts.

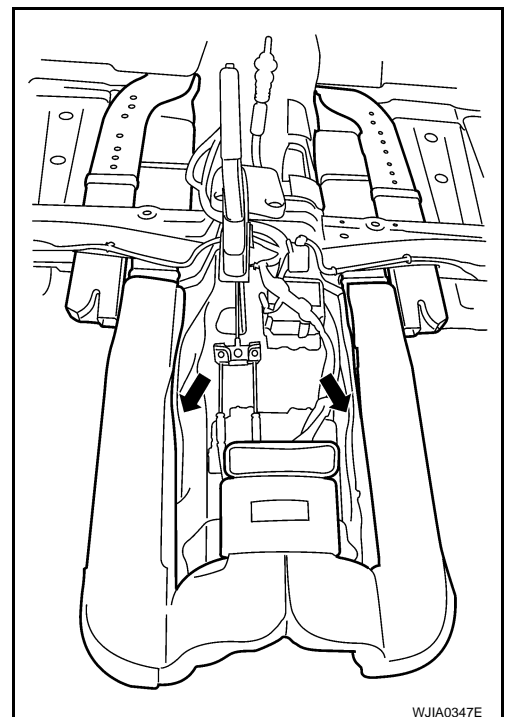

A
B
C
D
E
F
G
H
I

ATC

K
L
M
N
O
P

DUCTS AND GRILLES

< SERVICE INFORMATION >

Installation

Installation is in the reverse order of removal.

REFRIGERANT LINES

< SERVICE INFORMATION >

REFRIGERANT LINES

HFC-134a (R-134a) Service Procedure

INFOID:000000001721341

SETTING OF SERVICE TOOLS AND EQUIPMENT

Discharging Refrigerant

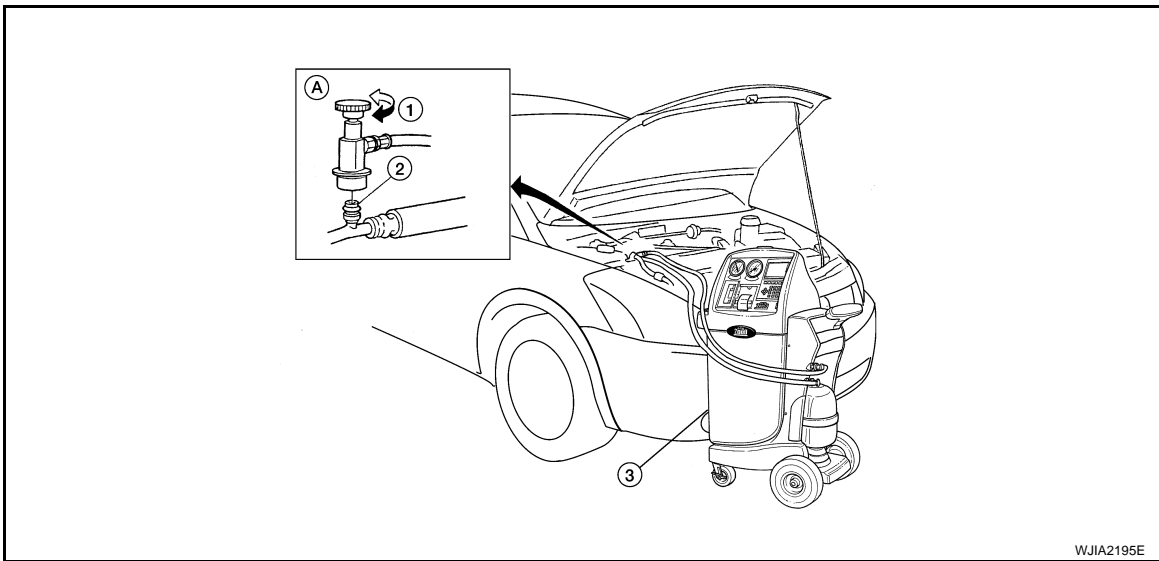

1. Shut-off valve 2. A/C service valve 3. Recovery/recycling equipment

A. Preferred (best) method

WARNING:

Avoid breathing A/C refrigerant and oil vapor or mist. Exposure may irritate eyes, nose and throat. Remove HFC-134a (R-134a) from A/C system using certified service equipment meeting requirements of SAE J2210 (R-134a recycling equipment) or SAE J2201 (R-134a recovery equipment). If accidental system discharge occurs, ventilate work area before resuming service. Additional health and safety information may be obtained from refrigerant and oil manufacturers.

ATC

Evacuating System and Charging Refrigerant

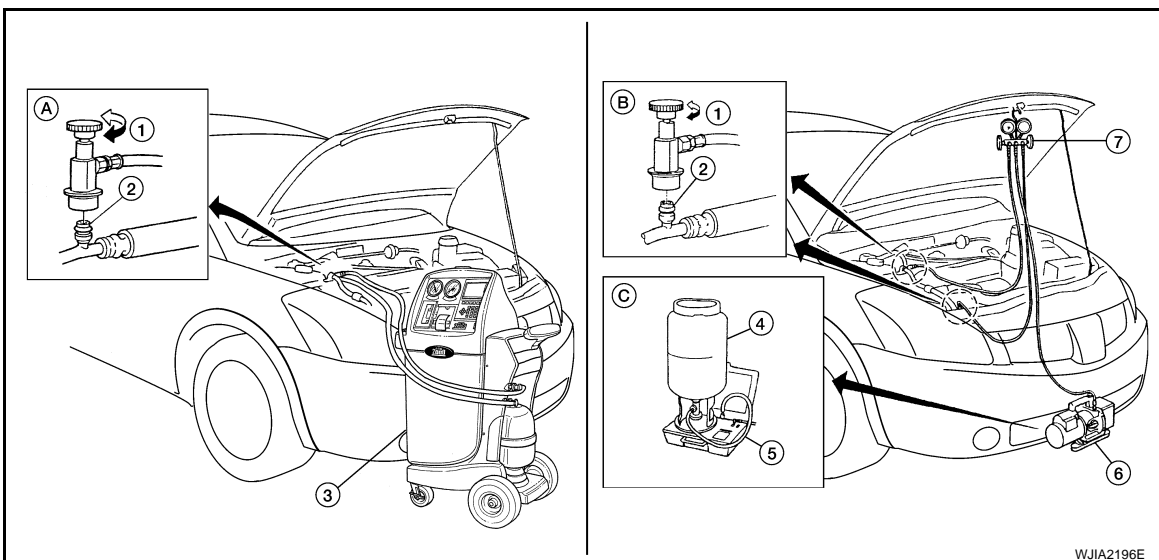

1. Shut-off valve 2. A/C service valve 3. Recovery/recycling equipment
4. Refrigerant container (HFC-134a) 5. Weight scale (J-39650) 6. Evacuating vacuum pump (J-39699)

REFRIGERANT LINES

< SERVICE INFORMATION >

7. Manifold gauge set (J-39183) A. Preferred (best) method B. Alternative method
 C. For charging

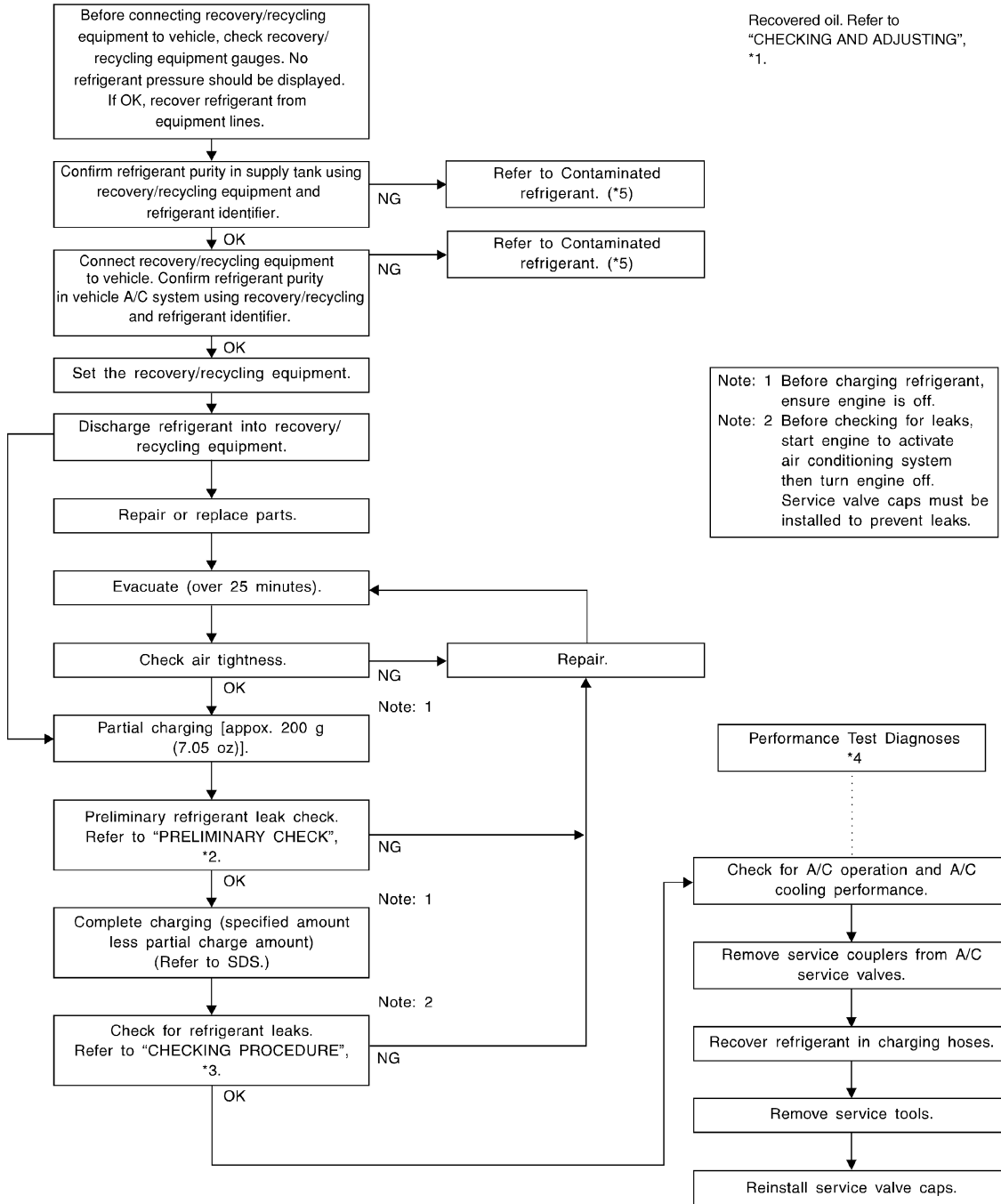

WJIA1923E

*1 [ATC-16, "Maintenance of Oil Quantity in Compressor"](#).

*2 [ATC-119, "Checking of Refrigerant Leaks"](#).

*3 [ATC-119, "Checking of Refrigerant Leaks"](#).

*4 [ATC-65, "Insufficient Cooling"](#).

*5 [ATC-3, "Contaminated Refrigerant"](#).

REFRIGERANT LINES

< SERVICE INFORMATION >

Component

INFOID:000000001721342

Refer to [ATC-4, "Precaution for Refrigerant Connection"](#).

SEC. 214 • 271 • 274 • 276

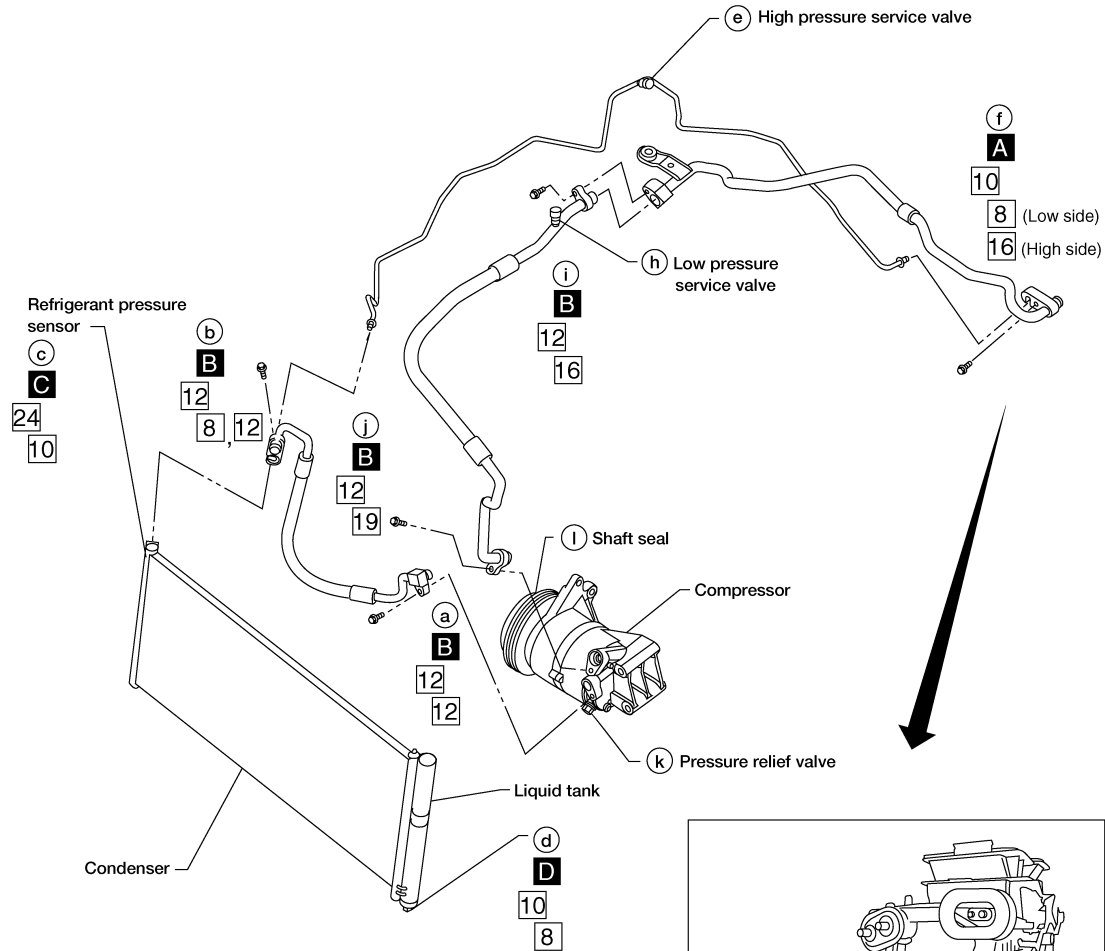

- : Refrigerant leak checking order
- : (Tightening torque)
- □ : (Wrench size)
- : (O-ring size)
- ⊗ : N·m (kg-m, in-lb)
- ⊙ : N·m (kg-m, ft-lb)
- A** ⊗ : 2.9 – 5.9 (0.29 – 0.60, 26 – 52)
- B** ⊗ : 7.8 – 19.6 (0.8 – 1.9, 69 – 173)
- C** ⊗ : 9.8 – 11.7 (1.0 – 1.1, 7.3 – 8.6)
- D** ⊗ : 5.0 – 6.47 (0.51 – 0.65, 45 – 57)

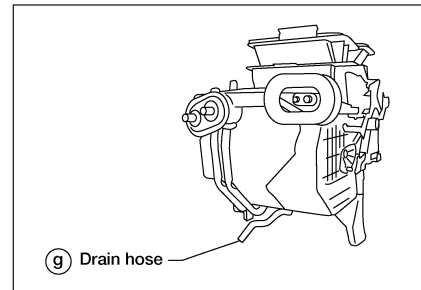

A
B
C
D
E
F
G
H
I
K
L
M
N
O
P

ATC

WJIA0982E

REFRIGERANT LINES

< SERVICE INFORMATION >

Removal and Installation for Compressor

INFOID:000000001721343

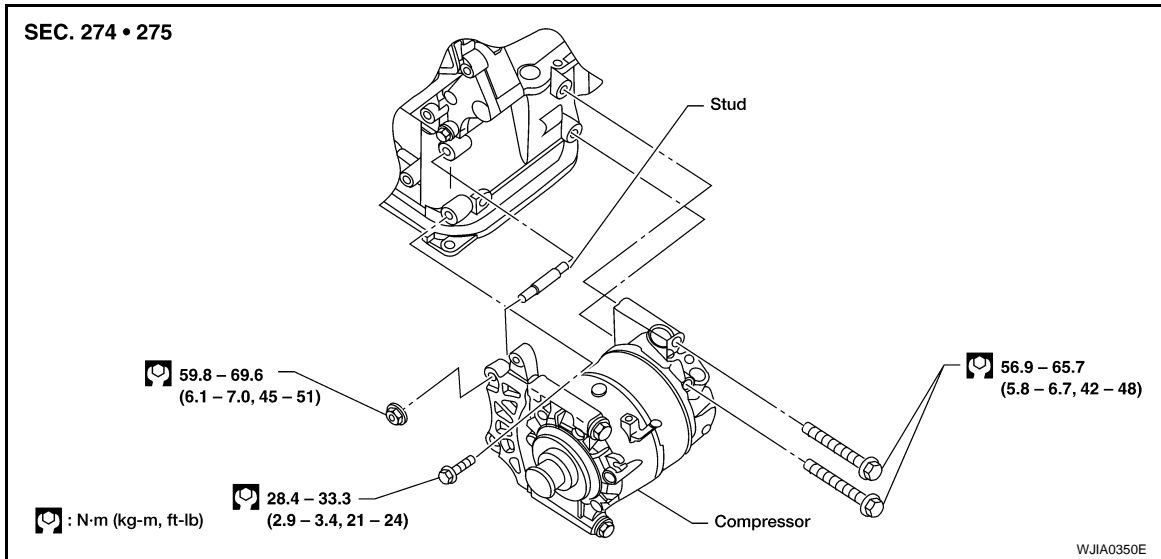

REMOVAL

1. Discharge the refrigerant. Refer to [ATC-109, "HFC-134a \(R-134a\) Service Procedure"](#).
2. Remove the drive belt. Refer to [MA-13, "Drive Belts"](#).
3. Remove the coolant pipe bracket bolt.
4. Remove the compressor mounting stud.
5. Disconnect the compressor connector.
6. Remove the high-pressure flexible hose and low-pressure flexible hose.

CAUTION:

Cap or wrap the joint of the pipe with suitable material such as vinyl tape to avoid the entry of air.

7. Remove the mounting bolts and nut from compressor using power tools.

INSTALLATION

Installation is in the reverse order of removal.

High- and low-pressure flexible hose bolts : Refer to [ATC-111, "Component"](#).

CAUTION:

- Replace the O-ring of the low-pressure flexible hose and high-pressure flexible hose with a new one, then apply compressor oil to it when installing it.
- When charging refrigerant, check for leaks.

Removal and Installation for Compressor Clutch

INFOID:000000001721344

REMOVAL

1. Remove the compressor. Refer to [ATC-112, "Removal and Installation for Compressor"](#).
2. Remove the center bolt by holding the clutch disc steady using Tool.

Tool number : (J-44614)

3. Remove the clutch disc.

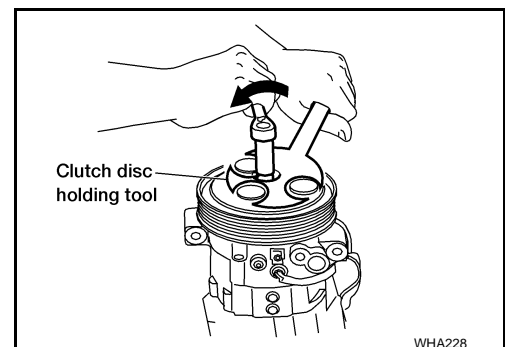

REFRIGERANT LINES

< SERVICE INFORMATION >

4. Remove the snap ring using external snap ring pliers.

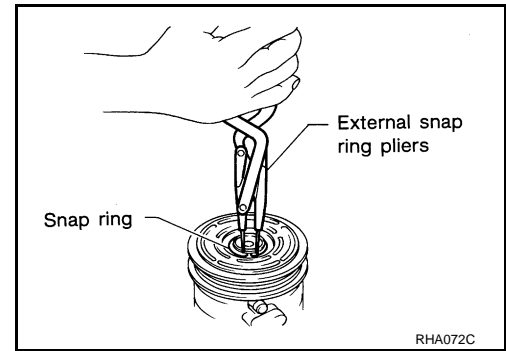

5. Remove the pulley assembly using Tool.
- Use a pulley puller with a small adapter. Position the small adapter on the end of the compressor shaft and the center of the puller on the small adapter as shown.

Tool number : KV99233130 (J-29884)

CAUTION:

To prevent deformation of the pulley groove, the puller claws should be hooked under (not into) the pulley groove.

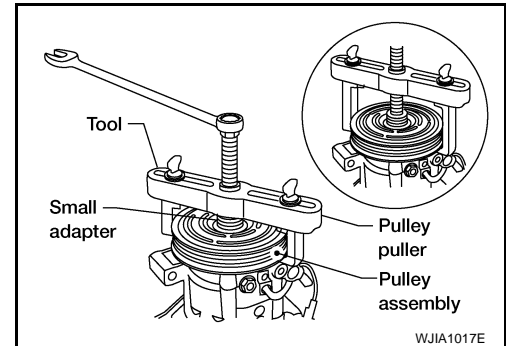

6. Remove the snap ring using external snap ring pliers.
7. Remove the magnet coil harness clip using a screwdriver.

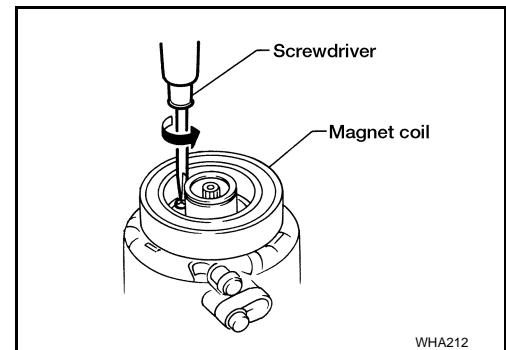

8. Remove the three magnet coil screws and remove the magnet coil.

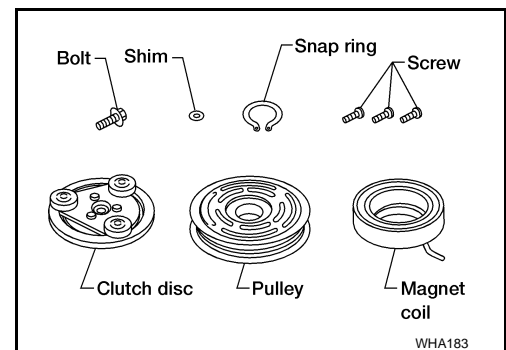

INSPECTION AFTER REMOVAL

Clutch Disc

If the contact surface shows signs of damage due to excessive heat, replace clutch disc and pulley.

Pulley

Check the appearance of the pulley assembly. If the contact surface of the pulley shows signs of excessive grooving, replace the clutch disc and pulley. The contact surfaces of the pulley assembly should be cleaned with a suitable solvent before installation.

Coil

Check the magnet coil for a loose connection or cracked insulation.

A
B
C
D
E
F
G
H
I
K
L
M
N
O
P

ATC

REFRIGERANT LINES

< SERVICE INFORMATION >

INSTALLATION

1. Install the magnet coil.

CAUTION:

Be sure to align the magnet coil pin with the hole in the compressor front head.

2. Install the magnet coil harness clip using a screwdriver.

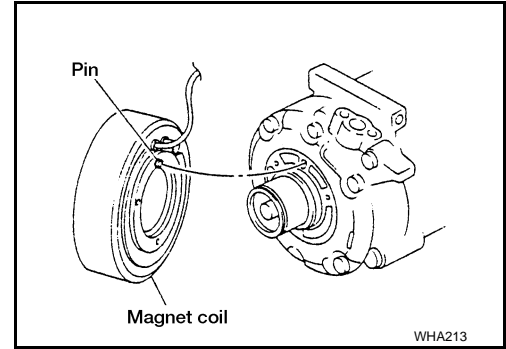

3. Install the pulley assembly using Tool and a wrench, and then install the snap ring using snap ring pliers.

Tool number : — (J-38873-A)

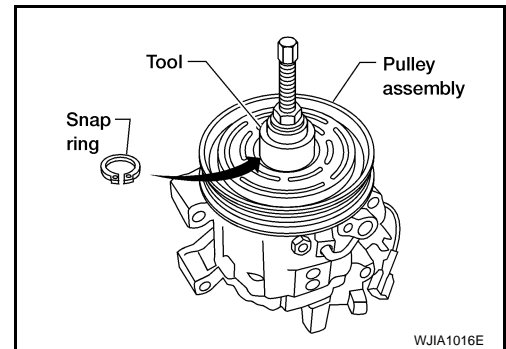

4. Install the clutch disc on the drive shaft, together with the original shim(s). Press the clutch disc down using the drive plate installer.

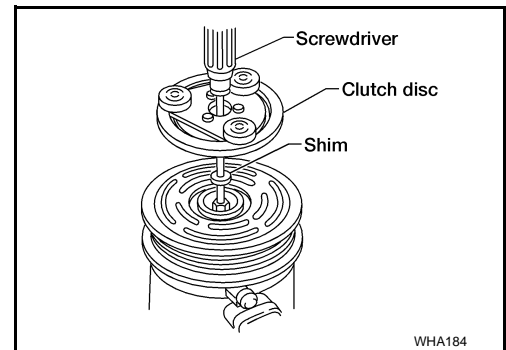

5. Install the center bolt using Tool.

Center bolt : 21 N·m (2.1 kg-m, 15 ft-lb)

Tool number : (J-44614)

- After tightening the center bolt to specification, check that the pulley rotates smoothly.

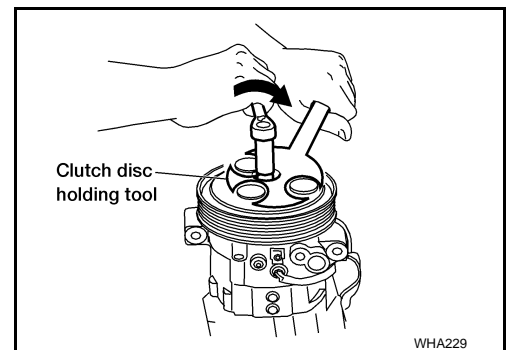

INSPECTION AFTER INSTALLATION

REFRIGERANT LINES

< SERVICE INFORMATION >

Check the clearance all the way around the clutch disc as shown.

**Clutch disc-to-pulley clearance : 0.3 - 0.6 mm
(0.012 - 0.024 in)**

If the specified clearance is not obtained, replace the adjusting spacer and recheck the clearance.

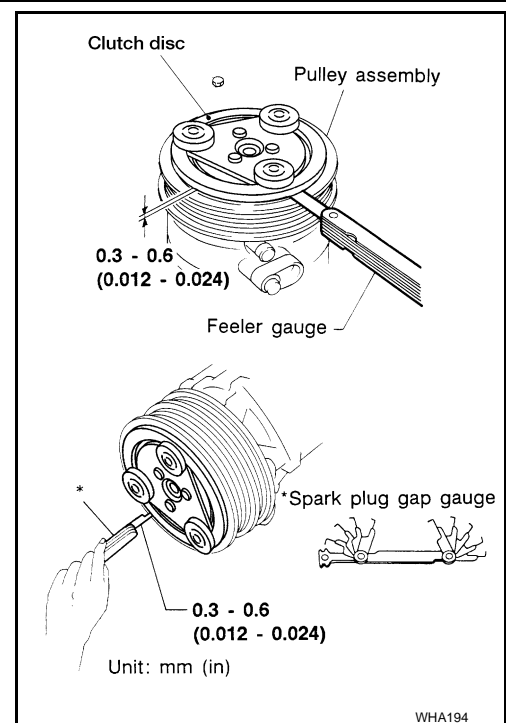

BREAK-IN OPERATION

When replacing compressor clutch assembly, always conduct the break-in operation. This is done by engaging and disengaging the clutch about 30 times. Break-in operation raises the level of transmitted torque.

Removal and Installation for Low-Pressure Flexible Hose

INFOID:000000001721345

REMOVAL

1. Discharge the refrigerant. Refer to [ATC-109, "HFC-134a \(R-134a\) Service Procedure"](#).
2. Remove the refrigerant pressure sensor.
3. Remove the low-pressure flexible hose. Refer to [ATC-111, "Component"](#).

CAUTION:

Cap or wrap the joint of the pipe with suitable material such as vinyl tape to avoid the entry of air.

INSTALLATION

Installation is in the reverse order of removal.

Low-pressure flexible hose (evaporator side) bolt : Refer to [ATC-111, "Component"](#).
Low-pressure flexible hose (compressor side) bolt : Refer to [ATC-111, "Component"](#).
Low-pressure flexible hose (in-line connection) bolt : Refer to [ATC-111, "Component"](#).

CAUTION:

- Replace the O-ring of the low-pressure flexible hose with a new one, then apply compressor oil to it when installing it.
- After charging refrigerant, check for leaks. Refer to [ATC-119, "Checking of Refrigerant Leaks"](#).

Removal and Installation for High-pressure Flexible Hose

INFOID:000000001721346

REMOVAL

1. Discharge the refrigerant. Refer to [ATC-109, "HFC-134a \(R-134a\) Service Procedure"](#).
2. Reposition the power steering reservoir out of the way without disconnecting the hose.
3. Reposition the engine coolant reservoir out of the way without disconnecting the hose.
4. Remove the high-pressure flexible hose. Refer to [ATC-111, "Component"](#).

CAUTION:

Cap or wrap the joint of the pipe with suitable material such as vinyl tape to avoid the entry of air.

REFRIGERANT LINES

< SERVICE INFORMATION >

INSTALLATION

Installation is in the reverse order of removal.

High-pressure flexible hose bolt : Refer to [ATC-111, "Component"](#).

CAUTION:

- Replace the O-ring of the high-pressure flexible hose with a new one, then apply compressor oil to it when installing it.
- After charging refrigerant, check for leaks. Refer to [ATC-119, "Checking of Refrigerant Leaks"](#).

Removal and Installation for High-pressure Pipe

INFOID:000000001721347

REMOVAL

1. Discharge the refrigerant. Refer to [ATC-109, "HFC-134a \(R-134a\) Service Procedure"](#).
2. Reposition the power steering reservoir out of the way without disconnecting the hose.
3. Reposition the engine coolant reservoir out of the way without disconnecting the hose.
4. Remove the high-pressure pipe. Refer to [ATC-111, "Component"](#).

CAUTION:

Cap or wrap the joint of the pipe with suitable material such as vinyl tape to avoid the entry of air.

INSTALLATION

Installation is in the reverse order of removal.

High-pressure pipe (evaporator side) bolt : Refer to [ATC-111, "Component"](#).

High-pressure pipe (condenser side) bolt : Refer to [ATC-111, "Component"](#).

CAUTION:

- Replace the O-ring of the high-pressure pipe with a new one, then apply compressor oil to it when installing it.
- After charging refrigerant, check for leaks. Refer to [ATC-119, "Checking of Refrigerant Leaks"](#).

Removal and Installation for Refrigerant Pressure Sensor

INFOID:000000001721348

REMOVAL

1. Discharge the refrigerant. Refer to [ATC-109, "HFC-134a \(R-134a\) Service Procedure"](#).
2. Disconnect the refrigerant pressure sensor connector and remove the refrigerant pressure sensor from condenser.

CAUTION:

Do not damage the condenser fins.

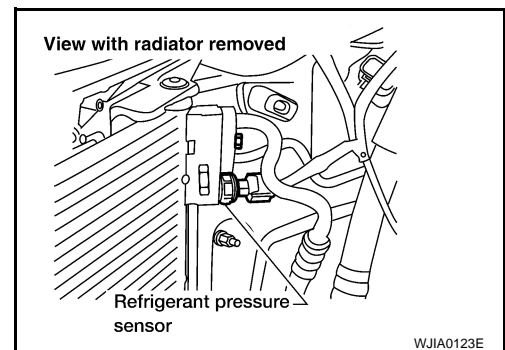

INSTALLATION

Installation is in the reverse order of removal.

CAUTION:

Replace the O-ring of the refrigerant pressure sensor with a new one, then apply compressor oil to it when installing it.

Refrigerant pressure sensor : Refer to [ATC-111, "Component"](#).

Removal and Installation for Condenser

INFOID:000000001721349

REMOVAL

1. Discharge the refrigerant. Refer to [ATC-109, "HFC-134a \(R-134a\) Service Procedure"](#).

REFRIGERANT LINES

< SERVICE INFORMATION >

2. Remove the radiator. Refer to [CO-13](#).

CAUTION:

Be careful not to damage the core surface of the condenser and the radiator.

3. Disconnect the high-pressure flexible hose and the high-pressure pipe from the condenser.

CAUTION:

Cap or wrap the joint of the pipe with suitable material such as vinyl tape to avoid the entry of air.

4. Disconnect the refrigerant pressure sensor connector.
5. Remove the front fascia. Refer to [EI-13](#).

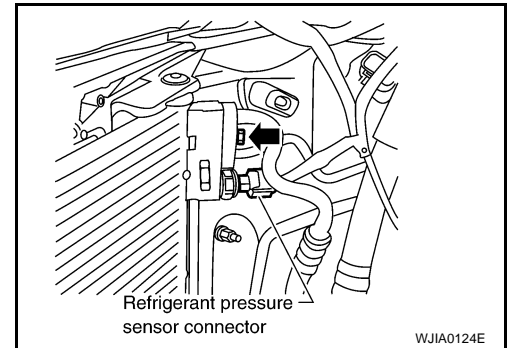

6. Remove the mounting nuts from condenser mounting brackets.
7. Remove the condenser.

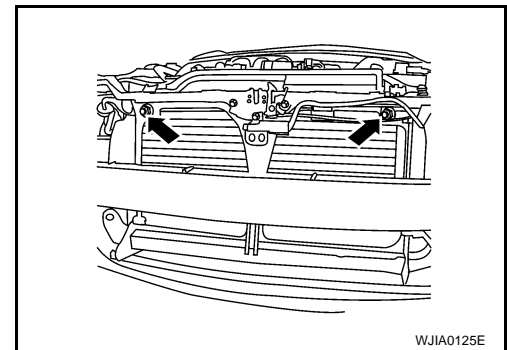

INSTALLATION

Installation is in the reverse order of removal.

High-pressure flexible hose and pipe bolt

: Refer to [ATC-111, "Component"](#).

Condenser mounting nuts

: 5.0 - 6.79 N·m (0.51 - 0.69 kg·m, 45 - 60 in·lb)

CAUTION:

- Replace the O-rings of the high-pressure pipe, refrigerant pressure sensor, and high-pressure flexible hose with new ones, then apply compressor oil to them when installing them.
- After charging refrigerant, check for leaks. Refer to [ATC-119, "Checking of Refrigerant Leaks"](#).

Removal and Installation for Evaporator

INFOID:000000001721350

REMOVAL

1. Evacuate and recover the A/C system refrigerant. Refer to [ATC-109, "HFC-134a \(R-134a\) Service Procedure"](#).
2. Disconnect the battery negative terminal.
3. Remove the air cleaner to electronic throttle control actuator tube. Refer to [EM-16](#).

NOTE:

The tube is located between the air cleaner assembly and the intake manifold and is removed to access the expansion valve.

4. Disconnect the A/C pipe from the expansion valve.

CAUTION:

Cap or wrap the joint of the pipe with suitable material such as vinyl tape to avoid the entry of air.

REFRIGERANT LINES

< SERVICE INFORMATION >

5. Remove the expansion valve.
6. Remove the center console side finisher RH. Refer to [IP-10](#).
7. Remove the glove box assembly. Refer to [IP-15](#). "[Glove Box Assembly and Housing](#)".
8. Remove the ECM.
 - Disconnect the ECM connector.
 - Remove the wire harness from the ECM mounting bracket.
 - Remove the two ECM mounting bracket nuts and disconnect the ground wire.
9. Remove the blower unit. Refer to [ATC-97](#).
10. Remove the heater core cover.

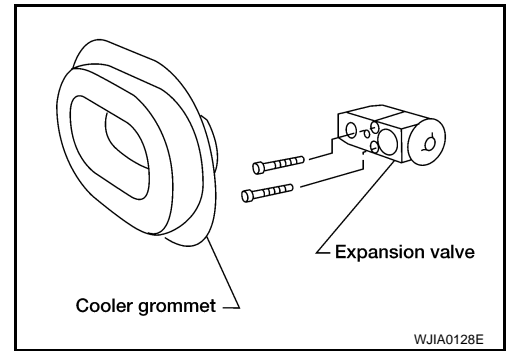

11. Remove the evaporator cover.

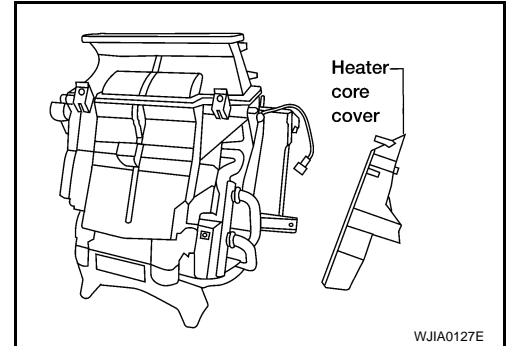

12. Remove the evaporator.
 - Remove the intake sensor.

CAUTION:

Mark the mounting position of the intake sensor for installation.

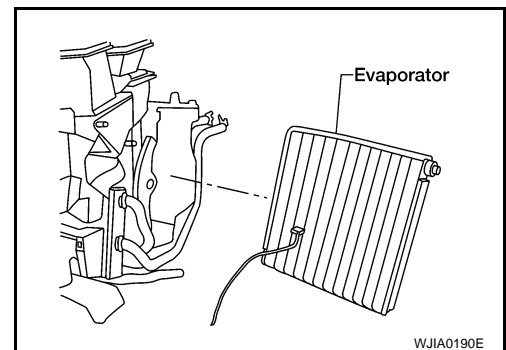
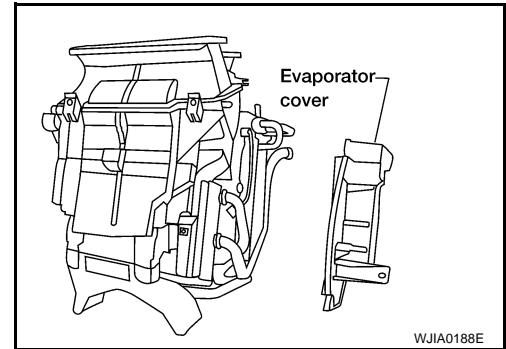

INSTALLATION

Installation is in the reverse order of removal.

Expansion valve bolts : 2.9 - 5.0 N-m (0.29 - 0.51 kg-m, 26 - 44 in-lb)

CAUTION:

- Replace the O-rings with new ones, then apply compressor oil to them when installing them.
- After charging refrigerant, check for leaks. Refer to [ATC-119](#). "[Checking of Refrigerant Leaks](#)".

Removal and Installation for Expansion Valve

INFOID:000000001721351

REMOVAL

REFRIGERANT LINES

< SERVICE INFORMATION >

1. Evacuate and recover the A/C system refrigerant. Refer to [ATC-109, "HFC-134a \(R-134a\) Service Procedure"](#).
2. Remove the air cleaner to electronic throttle control actuator tube. Refer to [EM-16](#).
NOTE:
The tube is located between the air cleaner assembly and the intake manifold and is removed to access the expansion valve.
3. Disconnect the A/C pipe from the expansion valve.
CAUTION:
Cap or wrap the joint of the pipe with suitable material such as vinyl tape to avoid the entry of air.
4. Remove the expansion valve.

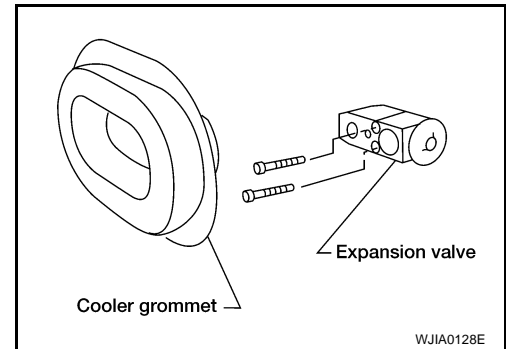

INSTALLATION

Installation is in the reverse order of removal.

Expansion valve mounting bolts : 2.9 - 5.0 N-m (0.29 - 0.51 kg-m, 26 - 44 in-lb)

CAUTION:

- Replace the O-rings with new ones, then apply compressor oil to them when installing them.
- After charging refrigerant, check for leaks. Refer to [ATC-119, "Checking of Refrigerant Leaks"](#).

Checking of Refrigerant Leaks

INFOID:000000001721352

- Perform a visual inspection of all refrigeration parts, fittings, hoses and components for signs of A/C oil leakage, damage and corrosion. A/C oil leakage may indicate an area of refrigerant leakage. Allow extra inspection time in these areas when using either an electronic refrigerant leak detector or fluorescent dye leak detector.
If dye is observed, confirm the leak with an electronic refrigerant leak detector. It is possible a prior leak was repaired and not properly cleaned.
- When searching for leaks, do not stop when one leak is found but continue to check for additional leaks at all system components and connections.
- When searching for refrigerant leaks using an electronic leak detector, move the probe along the suspected leak area at 25 - 50 mm (1 - 2 in) per second and no further than 6 mm (1/4 in) from the component.

ATC

K

L

M

N

O

P

CAUTION:

Moving the electronic leak detector probe slower and closer to the suspected leak area will improve the chances of finding a leak.

Checking System for Leaks Using the Fluorescent Leak Detector

INFOID:000000001721353

1. Check A/C system for leaks using the UV lamp and safety goggles (J-42220) in a low sunlight area (area without windows preferable). Illuminate all components, fittings and lines. The dye will appear as a bright green/yellow area at the point of leakage. Fluorescent dye observed at the evaporator drain opening indicates an evaporator core assembly (tubes, core or TXV) leak.
2. If the suspected area is difficult to see, use an adjustable mirror or wipe the area with a clean shop rag or cloth, with the UV lamp for dye residue.
3. After the leak is repaired, remove any residual dye using refrigerant dye cleaner (J-43872) to prevent future misdiagnosis.
4. Perform a system performance check and verify the leak repair with an approved electronic refrigerant leak detector.

NOTE:

REFRIGERANT LINES

< SERVICE INFORMATION >

- Other gases in the work area or substances on the A/C components, for example, anti-freeze, windshield washer fluid, solvents and oils, may falsely trigger the leak detector. Make sure the surfaces to be checked are clean.
Clean with a dry cloth or blow off with shop air.
- Do not allow the sensor tip of the detector to contact with any substance. This can also cause false readings and may damage the detector.

Dye Injection

INFOID:000000001721354

NOTE:

This procedure is only necessary when recharging the system or when the compressor has seized and was replaced.

1. Check A/C system static (at rest) pressure. Pressure must be at least 345 kPa (3.52 kg/cm², 50 psi).
2. Pour one bottle (1/4 ounce / 7.4 cc) of the A/C refrigerant dye into the injector tool (J-41459).
3. Connect the injector tool to the A/C LOW PRESSURE side service fitting.
4. Start engine and switch A/C ON.
5. When the A/C operating (compressor running), inject one bottle (1/4 ounce / 7.4 cc) of fluorescent dye through the low-pressure service valve using dye injector tool J-41459 (refer to the manufacturer's operating instructions).
6. With the engine still running, disconnect the injector tool from the service fitting.

CAUTION:

If repairing the A/C system or replacing a component, pour the dye directly into the open system connection and proceed with the service procedures.

7. Operate the A/C system for a minimum of 20 minutes to mix the dye with the system oil. Depending on the leak size, operating conditions and location of the leak, it may take from minutes to days for the dye to penetrate a leak and become visible.

Electronic Refrigerant Leak Detector

INFOID:000000001721355

PRECAUTIONS FOR HANDLING LEAK DETECTOR

When performing a refrigerant leak check, use a electronic refrigerant leak detector (J-41995) or equivalent. Ensure that the instrument is calibrated and set properly per the operating instructions.

The electronic refrigerant leak detector (J-41995) is a delicate device. In order to use the electronic refrigerant leak detector (J-41995) properly, read the operating instructions and perform any specified maintenance.

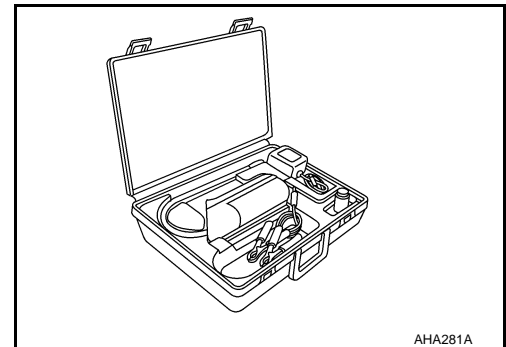

1. Position probe approximately 5 mm (3/16 in) away from point to be checked.

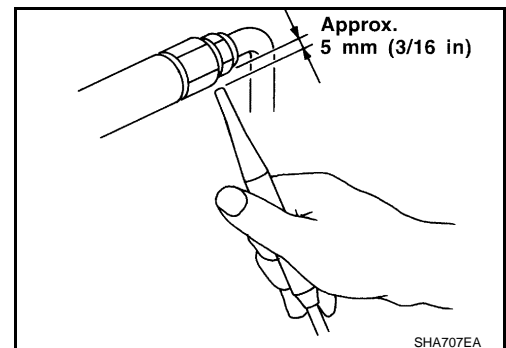

REFRIGERANT LINES

< SERVICE INFORMATION >

- When testing, circle each fitting completely with probe.

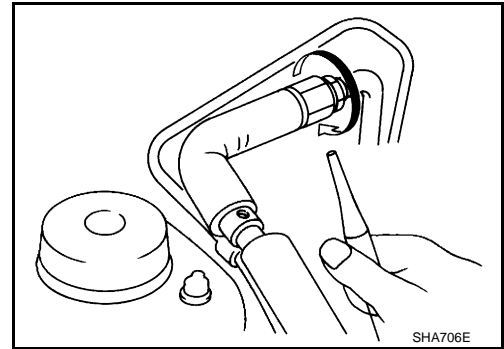

- Move probe along component approximately 25 to 50 mm (1 to 2 in)/sec.

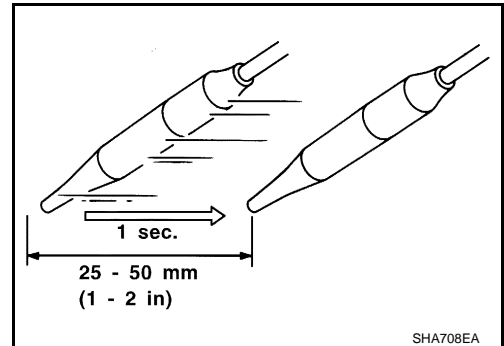

CHECKING PROCEDURE

To prevent inaccurate or false readings, make sure there is no refrigerant vapor, shop chemicals, or cigarette smoke in the vicinity of the vehicle. Perform the leak test in calm area (low air/wind movement) so that the leaking refrigerant is not dispersed.

- Turn engine OFF.
- Connect a suitable A/C manifold gauge set to the A/C service ports.
- Check if the A/C refrigerant pressure is at least 345 kPa (3.52 kg/cm², 50 psi) above 16°C (61°F). If less than specification, recover/evacuate and recharge the system with the specified amount of refrigerant.

NOTE:

At temperatures below 16°C (61°F), leaks may not be detected since the system may not reach 345 kPa (3.52 kg/cm², 50 psi).

- Conduct the leak test from the high side (compressor discharge a to evaporator inlet f) to the low side (evaporator drain hose g to shaft seal l). Refer to [ATC-111, "Component"](#). Perform a leak check for the following areas carefully. Clean the component to be checked and move the leak detected probe completely around the connection/component.
 - Compressor
 - Check the fitting of high- and low-pressure hoses, relief valve and shaft seal.
 - Liquid tank
 - Check the refrigerant pressure sensor.
 - Service valves
 - Check all around the service valves. Make sure service valve caps are secured on the service valves (to prevent leaks).
 - After removing A/C manifold gauge set from service valves, wipe any residue from valves to prevent any false readings by leak detector.
 - Evaporator
 - With the engine OFF, turn the blower fan on High for at least 15 seconds to dissipate any refrigerant traces around the evaporator. Wait a minimum of 10 minutes accumulation time (refer to the manufacturer's recommended procedure for actual wait time) before inserting the leak detector probe into the drain hose.
 - Keep the probe inserted for at least 10 seconds. Use caution not to contaminate the probe tip with water or dirt that may be in the drain hose.
- If a leak detector detects a leak, verify at least once by blowing compressed air into area of suspected leak, then repeat check as outlined above.
- Do not stop when one leak is found. Continue to check for additional leaks at all system components. If no leaks are found, perform steps 7 - 10.

A

B

C

D

E

F

G

H

I

ATC

K

L

M

N

O

P

REFRIGERANT LINES

< SERVICE INFORMATION >

7. Start engine.
8. Set the heater A/C control as follows;
 - a. A/C switch: ON
 - b. Mode: Vent
 - c. Intake position: Recirculation
 - d. Temperature: MAX cold
 - e. Blower fan speed: High
9. Run the engine at 1,500 rpm for at least 2 minutes.
10. Turn the engine off and perform leak check again following steps 4 through 6 above.

Refrigerant leaks should be checked immediately after stopping the engine. Begin with the leak detector at the compressor. The pressure on the high pressure side will gradually drop after refrigerant circulation stops and pressure on the low pressure side will gradually rise, as shown in the graph. Some leaks are more easily detected when the pressure is high.

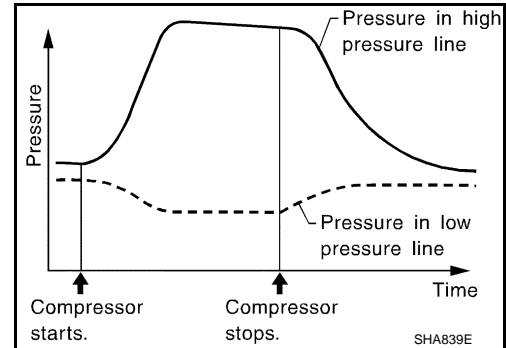

11. Before connecting the recovery/recycling equipment to the vehicle, check the recovery/recycling equipment gauges. No refrigerant pressure should be displayed. If pressure is displayed, recover the refrigerant from the recovery/recycling equipment lines and then check the refrigerant purity.
12. Confirm the refrigerant purity in supply tank using the refrigerant identifier equipment.
13. Confirm the refrigerant purity in the A/C system using the refrigerant identifier equipment.
14. Discharge the A/C system using approved recovery/recycling equipment. Repair the leaking fitting or component as necessary.
15. Evacuate and recharge the A/C system using approved recovery/recycling equipment and perform the leak test to confirm that there are no refrigerant leaks.
16. Conduct the A/C performance test to ensure that the A/C system works properly.

SERVICE DATA AND SPECIFICATIONS (SDS)

< SERVICE INFORMATION >

SERVICE DATA AND SPECIFICATIONS (SDS)

Service Data and Specification (SDS)

INFOID:000000001721356

COMPRESSOR

Make	ZEXEL VALEO CLIMATE CONTROL
Model	DKS-17D
Type	Swash plate
Displacement	175.5 cm ³ (10.7 in ³) / revolution
Cylinder bore x stroke	30.5 x 24.0 mm (0.94 x 1.201 in)
Direction of rotation	Clockwise (viewed from drive end)
Drive belt	Poly V

LUBRICANT

Name	NISSAN A/C System Oil Type S	
Capacity	Total in system	150 mℓ (5.03 US fl oz, 5.3 Imp fl oz)
	Compressor (service part) charging amount	Refer to ATC-16. "Maintenance of Oil Quantity in Compressor" .

REFRIGERANT

Type	HFC-134a (R-134a)
Capacity	0.55 ± 0.025 kg (1.21 ± 0.055 lb)

ENGINE IDLING SPEED

Refer to [EC-74. "Idle Speed and Ignition Timing Check"](#).

BELT TENSION

Refer to [MA-13. "Drive Belts"](#).

A
B
C
D
E
F
G
H
I
K
L
M
N
O
P

ATC