

SECTION **STC**

STEERING CONTROL SYSTEM

A
B
C
D
E
F
G
H
I
J
K
L
M
N
O
P

CONTENTS

| | |
|---|--|
| <p>BASIC INSPECTION 2</p> <p>DIAGNOSIS AND REPAIR WORKFLOW 2</p> <p style="padding-left: 20px;">Work Flow2</p> <p>SYSTEM DESCRIPTION 3</p> <p>EPS SYSTEM 3</p> <p style="padding-left: 20px;">System Diagram3</p> <p style="padding-left: 20px;">System Description3</p> <p style="padding-left: 20px;">Component Parts Location4</p> <p style="padding-left: 20px;">Component Description5</p> <p>DTC/CIRCUIT DIAGNOSIS 6</p> <p>POWER SUPPLY AND GROUND CIRCUIT 6</p> <p style="padding-left: 20px;">Description6</p> <p style="padding-left: 20px;">Diagnosis Procedure6</p> <p>POWER STEERING SOLENOID VALVE 7</p> <p style="padding-left: 20px;">Description7</p> <p style="padding-left: 20px;">Diagnosis Procedure7</p> <p style="padding-left: 20px;">Component Inspection8</p> <p>ENGINE SPEED SIGNAL CIRCUIT 9</p> <p style="padding-left: 20px;">Description9</p> <p style="padding-left: 20px;">Diagnosis Procedure9</p> <p>VEHICLE SPEED SIGNAL CIRCUIT12</p> <p style="padding-left: 20px;">Description12</p> <p style="padding-left: 20px;">Diagnosis Procedure12</p> | <p>ECU DIAGNOSIS INFORMATION14</p> <p>POWER STEERING CONTROL UNIT14</p> <p style="padding-left: 20px;">Reference Value14</p> <p style="padding-left: 20px;">Fail Safe15</p> <p>WIRING DIAGRAM16</p> <p>ELECTRONICALLY CONTROLLED POWER STEERING SYSTEM16</p> <p style="padding-left: 20px;">Wiring Diagram16</p> <p>SYMPTOM DIAGNOSIS19</p> <p>UNBALANCE STEERING WHEEL TURNING FORCE (TORQUE VARIATION)19</p> <p style="padding-left: 20px;">Description19</p> <p style="padding-left: 20px;">Diagnosis Procedure19</p> <p>PRECAUTION20</p> <p>PRECAUTIONS20</p> <p style="padding-left: 20px;">Precaution for Supplemental Restraint System (SRS) "AIR BAG" and "SEAT BELT PRE-TENSIONER"20</p> <p>UNIT REMOVAL AND INSTALLATION21</p> <p>EPS CONTROL UNIT21</p> <p style="padding-left: 20px;">Removal and Installation21</p> |
|---|--|

STC

DIAGNOSIS AND REPAIR WORKFLOW

< BASIC INSPECTION >

BASIC INSPECTION

DIAGNOSIS AND REPAIR WORKFLOW

Work Flow

INFOID:000000007254740

DETAILED FLOW

1. COLLECT THE INFORMATION FROM THE CUSTOMER

It is also important to clarify customer complaints before inspection. First of all, reproduce symptoms, and understand them fully. Ask customer about his/her complaints carefully. In some cases, it will be necessary to check symptoms by driving vehicle with customer.

>> GO TO 2.

2. BASIC INSPECTION

1. Check the power steering fluid leakage and the power steering fluid level. Refer to [ST-12. "Inspection"](#).
2. Check the drive belt tension. Refer to [EM-14. "Checking Drive Belts"](#).
3. Check the power steering gear for damages, cracks and oil leakage. Refer to [ST-12. "Inspection"](#).
4. Check the relief oil pressure. Refer to [ST-16. "Inspection"](#).

>> GO TO 3.

3. TROUBLE DIAGNOSIS FOR SYMPTOM

Perform the diagnosis by symptom. Refer to [STC-19. "Description"](#).

>> GO TO 4.

4. FINAL CHECK

Check the input/output standard values for the power steering control unit.

Are the power steering control unit input/output values within standard ranges respectively?

- YES >> Inspection End
NO >> GO TO 2.

EPS SYSTEM

< SYSTEM DESCRIPTION >

SYSTEM DESCRIPTION

EPS SYSTEM

System Diagram

INFOID:000000007254741

CONTROL DIAGRAM

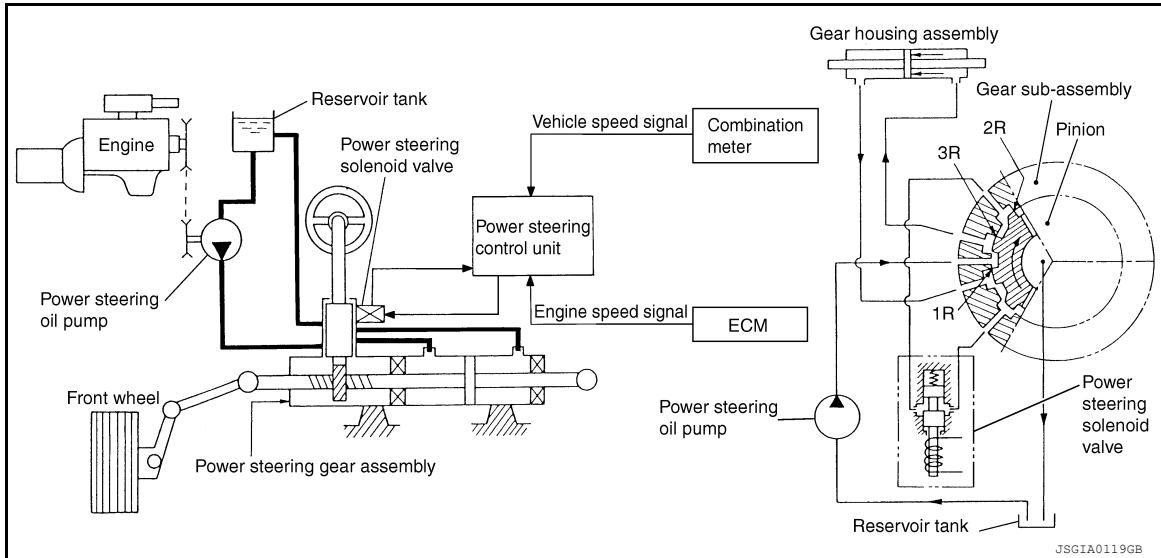

System Description

INFOID:000000007254742

- The EPS system controls the power steering solenoid valve through the power steering control unit.
- The valve driving voltage to control the power steering solenoid valve varies according to the vehicle speed.

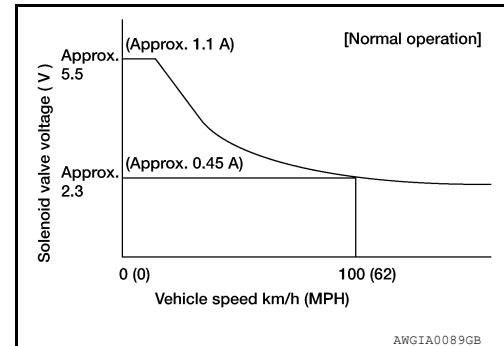

OPERATION PRINCIPLE

During Parking (When Turning The Steering Wheel To The Right)

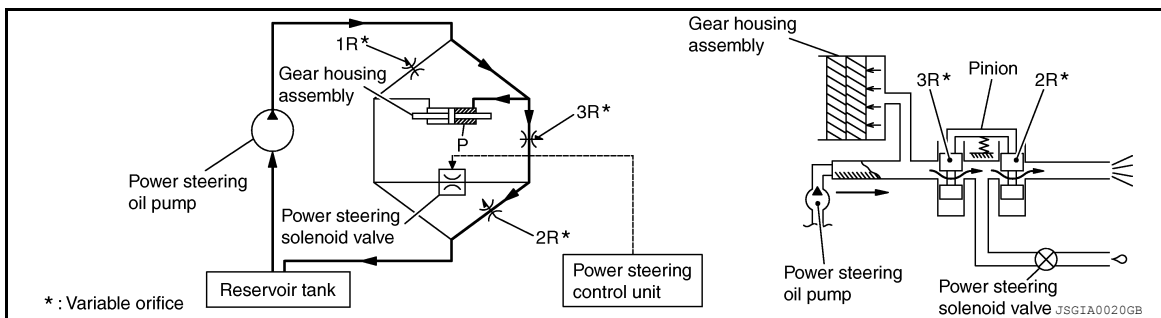

1. Power steering solenoid valve is closed while a vehicle is stopped.
2. Pinion "1R", "2R" and "3R" are closed depending on steering torque of steering wheel.
3. Oil pressure "P" in the gear housing assembly is the sum of oil pressures occurring in "2R" and "3R". This results in a light steering force because of high pressure.

During High-speed Operation

EPS SYSTEM

< SYSTEM DESCRIPTION >

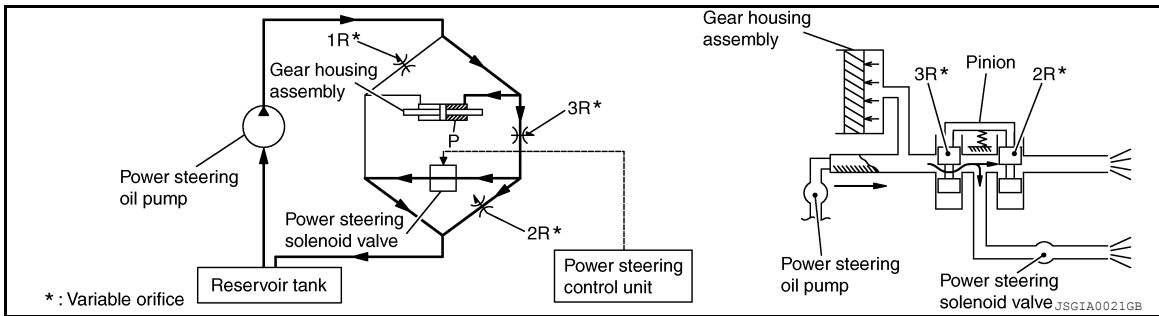

1. Power steering solenoid valve is opened during high-speed operation.
2. Pinion "1R", "2R" and "3R" are closed depending on steering torque of steering wheel.
3. Oil pressure "2R" does not occur because the power steering solenoid valve is on full throttle.
4. Oil pressure "P" in the gear housing assembly includes only oil pressure occurring in "3R" and results in a heavy steering force.

Component Parts Location

INFOID:000000007254743

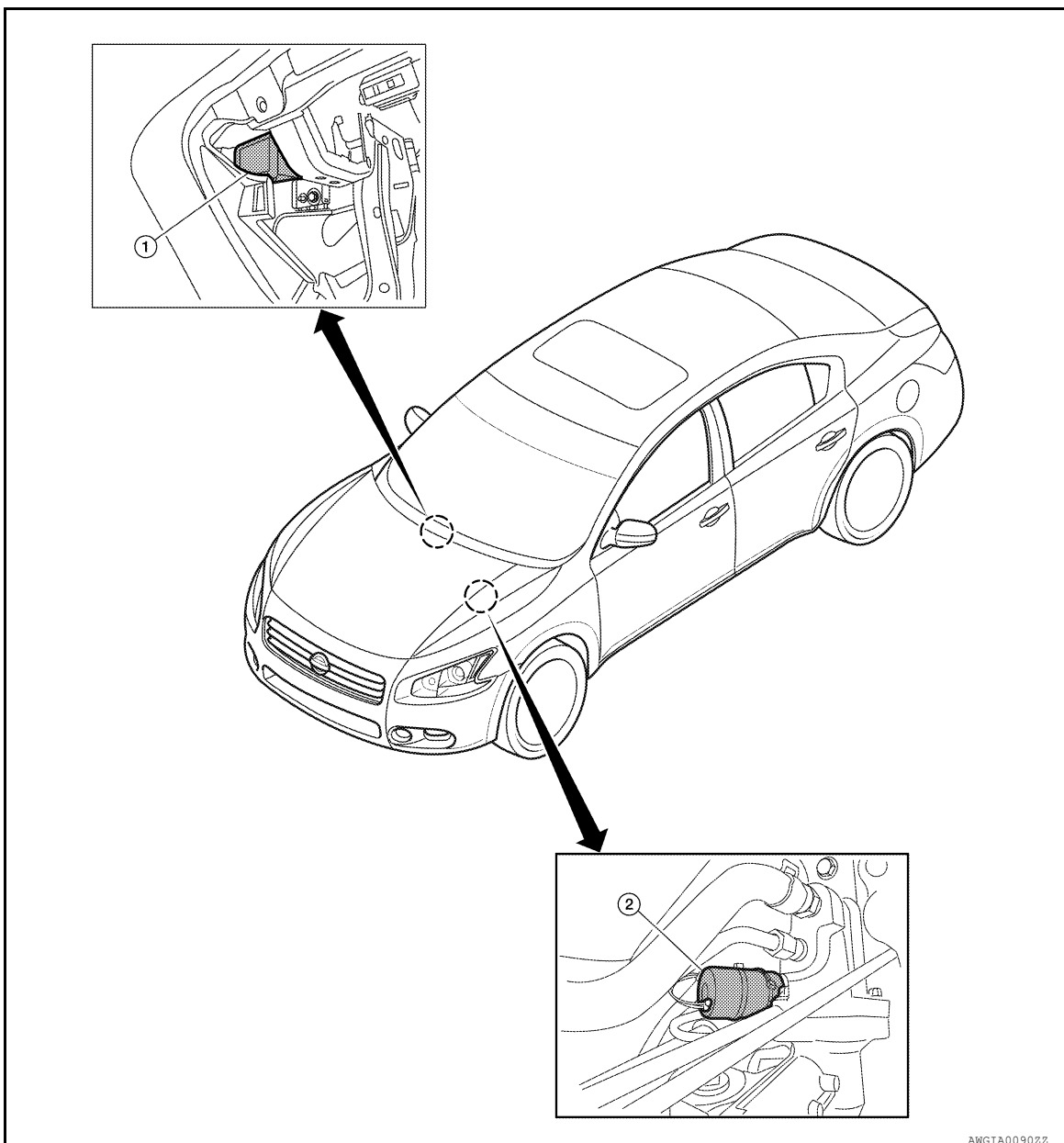

EPS SYSTEM

< SYSTEM DESCRIPTION >

1. Power steering control unit M59
(view with glove box removed)
2. Power steering solenoid valve E14

Component Description

INFOID:000000007254744

| Component parts | Function |
|-------------------------------|---|
| Power steering control unit | <ul style="list-style-type: none">• Signals from various sensors control the driving voltage to the power steering solenoid valve.• The power steering control unit controls the driving voltage to the power steering solenoid valve for maintaining the power steering assist force when the fail-safe function is activated. (The engine speed signals control EPS system if any vehicle speed signal error is detected.) |
| Combination meter | Refer to STC-12. "Description" . |
| ECM | Refer to STC-9. "Description" . |
| Power steering solenoid valve | Refer to STC-7. "Description" . |

A
B
C
D
E
F
H
I
J
K
L
M
N
O
P

STC

POWER SUPPLY AND GROUND CIRCUIT

< DTC/CIRCUIT DIAGNOSIS >

DTC/CIRCUIT DIAGNOSIS

POWER SUPPLY AND GROUND CIRCUIT

Description

INFOID:000000007254745

EPS system functions by ignition power supply.

Diagnosis Procedure

INFOID:000000007254746

Regarding Wiring Diagram information, refer to [STC-16. "Wiring Diagram"](#).

1. CHECK POWER SUPPLY

1. Turn the ignition switch OFF.
2. Disconnect power steering control unit connector.
3. Turn the ignition switch ON.
4. Check voltage between power steering control unit connector M59 terminal 3 and ground.

| Power steering control unit | | Ground | Condition | Voltage (Approx.) |
|-----------------------------|----------|--------|---------------------|-------------------|
| Connector | Terminal | | | |
| M59 | 3 | — | Ignition switch ON | Battery voltage |
| | | | Ignition switch OFF | 0V |

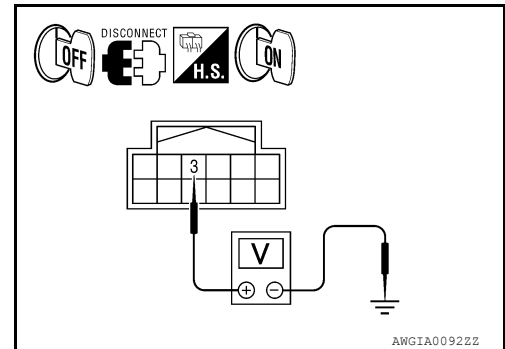

Is the inspection result normal?

- YES >> GO TO 2.
 NO >> Repair harness or connectors.

2. CHECK GROUND CIRCUIT

1. Turn the ignition switch OFF.
2. Check continuity between power steering control unit connector M59 terminal 6 and ground.

| Power steering control unit | | Ground | Continuity |
|-----------------------------|----------|--------|------------|
| Connector | Terminal | | |
| M59 | 6 | — | Yes |

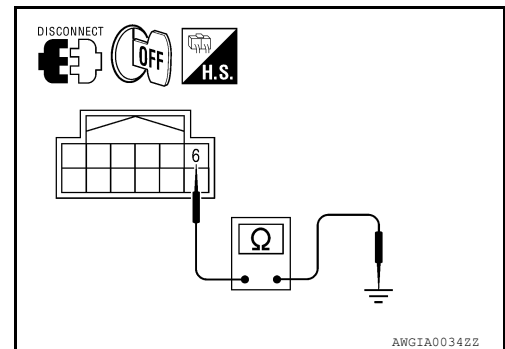

Is the inspection result normal?

- YES >> GO TO 3.
 NO >> Repair harness or connectors.

3. CHECK TERMINALS AND HARNESS CONNECTORS

Check power steering control unit pin terminals for damage or loose connection with harness connector.

Is the inspection result normal?

- YES >> Inspection End
 NO >> Repair or replace damaged parts.

POWER STEERING SOLENOID VALVE

< DTC/CIRCUIT DIAGNOSIS >

POWER STEERING SOLENOID VALVE

Description

INFOID:000000007254747

Power steering solenoid valve controls the power steering oil pressure in the gear housing assembly.

Diagnosis Procedure

INFOID:000000007254748

Regarding Wiring Diagram information, refer to [STC-16, "Wiring Diagram"](#).

1. CHECK POWER STEERING SOLENOID VALVE SIGNAL

1. Start engine.
2. Check voltage between power steering control unit connector M59 terminal 1 and ground.

| Power steering control unit | | Ground | Condition | Voltage (Approx.) |
|-----------------------------|----------|--------|--|-------------------|
| Connector | Terminal | | | |
| M59 | 1 | — | Vehicle speed: 0 km/h (0 MPH) (Engine is running) | 4.4 - 6.6 V |
| | | | Vehicle speed: 100 km/h (62 MPH) | 2.5 - 3.7 V |

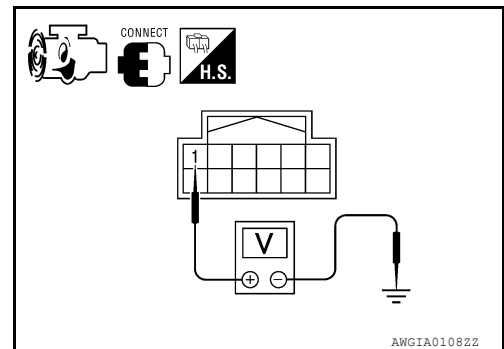

Is the inspection result normal?

- YES >> GO TO 2.
NO >> GO TO 4.

2. CHECK POWER STEERING SOLENOID VALVE HARNESS FOR OPEN

1. Turn ignition switch OFF.
2. Disconnect power steering solenoid valve connector.
3. Disconnect power steering control unit connector.
4. Check continuity between power steering solenoid valve connector E14 (A) terminals 1, 2 and power steering control unit connector M59 (B) terminal 1, 5.

| Power steering solenoid valve | | Power steering control unit | | Continuity |
|-------------------------------|----------|-----------------------------|----------|------------|
| Connector | Terminal | Connector | Terminal | |
| E14 (A) | 1 | M59 (B) | 1 | Yes |
| | 2 | | 5 | |

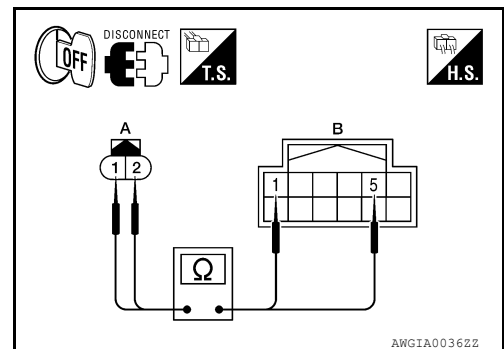

Is the inspection result normal?

- YES >> GO TO 3.
NO >> Repair harness or connectors.

3. CHECK POWER STEERING SOLENOID VALVE HARNESS FOR SHORT

1. Check continuity between power steering solenoid valve connector E14 terminals 1, 2 and ground.

| Power steering solenoid valve | | Ground | Continuity |
|-------------------------------|----------|--------|------------|
| Connector | Terminal | | |
| E14 | 1 | — | No |
| | 2 | | |

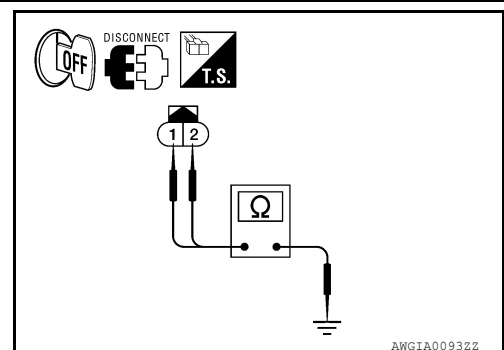

POWER STEERING SOLENOID VALVE

< DTC/CIRCUIT DIAGNOSIS >

- Turn ignition switch ON.
- Check voltage between power steering solenoid valve connector E14 terminals 1, 2 and ground.

| Power steering solenoid valve | | Ground | Voltage (Approx.) |
|-------------------------------|----------|--------|-------------------|
| Connector | Terminal | | |
| E14 | 1 | — | 0V |
| | 2 | | |

Is the inspection result normal?

- YES >> GO TO 4.
 NO >> Repair harness or connectors.

4.CHECK POWER STEERING SOLENOID VALVE

Perform power steering solenoid valve component inspection. Refer to [STC-8, "Component Inspection"](#).

Is the inspection result normal?

- YES >> GO TO 5.
 NO >> Replace power steering solenoid valve. Refer to [ST-33, "Exploded View"](#).

5.CHECK TERMINALS AND HARNESS CONNECTORS

- Check power steering control unit pin terminals for damage or loose connection with harness connector.
- Check power steering solenoid valve pin terminals for damage or loose connection with harness connector.

Is the inspection result normal?

- YES >> Inspection End
 NO >> Repair or replace damaged parts.

Component Inspection

INFOID:000000007254749

1.POWER STEERING SOLENOID VALVE RESISTANCE CHECK

- Turn ignition switch OFF.
- Disconnect power steering solenoid valve connector.
- Check resistance between power steering solenoid valve terminals 1 and 2

| Power steering solenoid valve terminals | Resistance (Approx.) |
|---|----------------------|
| 1 - 2 | 5 Ω |

Is the inspection result normal?

- YES >> GO TO 2.
 NO >> Replace power steering solenoid valve. Refer to [ST-33, "Exploded View"](#).

2.POWER STEERING SOLENOID VALVE OPERATION CHECK

Check power steering solenoid valve by listening for its operation sound while applying battery voltage to power steering solenoid valve terminal 1 (positive) and battery ground to terminal 2 (negative).

Is the inspection result normal?

- YES >> Inspection End
 NO >> Replace power steering solenoid valve. Refer to [ST-33, "Exploded View"](#).

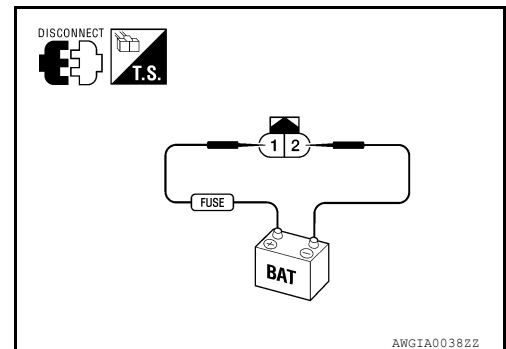
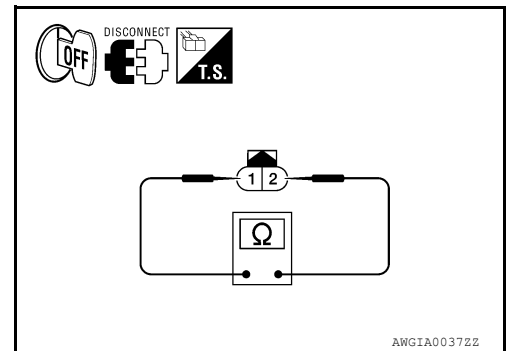
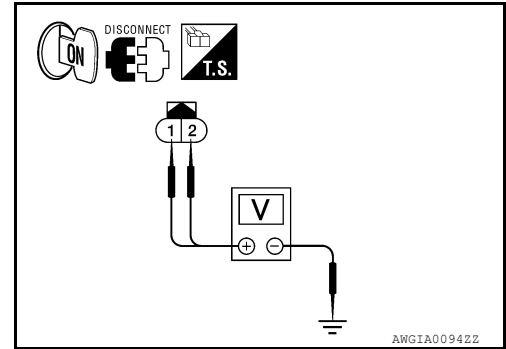

ENGINE SPEED SIGNAL CIRCUIT

< DTC/CIRCUIT DIAGNOSIS >

ENGINE SPEED SIGNAL CIRCUIT

Description

INFOID:000000007254750

ECM sends engine speed signal to power steering control unit.

Diagnosis Procedure

INFOID:000000007254751

Regarding Wiring Diagram information, refer to [STC-16, "Wiring Diagram"](#).

1. PERFORM ECM SELF-DIAGNOSIS

With CONSULT

Perform ECM self-diagnosis.

Is any error system detected?

- YES >> Check the error system.
- NO >> GO TO 2.

2. CHECK HARNESS BETWEEN ECM AND POWER STEERING CONTROL UNIT FOR OPEN

1. Turn the ignition switch OFF.
2. Disconnect ECM connector E10.
3. Disconnect power steering control unit connector.
4. Check continuity between ECM connector E10 (A) terminal 94 and power steering control unit connector M59 (B) terminal 10.

| ECM | | Power steering control unit | | Continuity |
|-----------|----------|-----------------------------|----------|------------|
| Connector | Terminal | Connector | Terminal | |
| E10 (A) | 94 | M59 (B) | 10 | Yes |

Is the inspection result normal?

- YES >> GO TO 3.
- NO >> Repair harness or connectors.

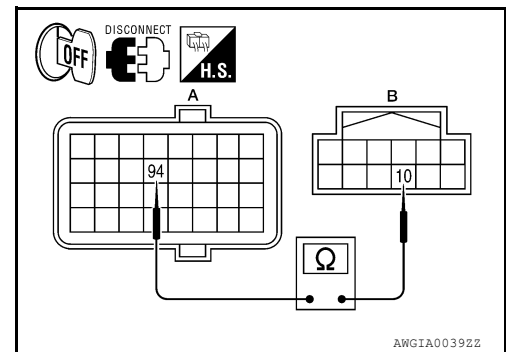

3. CHECK HARNESS BETWEEN ECM AND POWER STEERING CONTROL UNIT FOR SHORT

1. Check continuity between ECM connector E10 terminal 94 and ground.

| ECM | | Ground | Continuity |
|-----------|----------|--------|------------|
| Connector | Terminal | | |
| E10 | 94 | — | No |

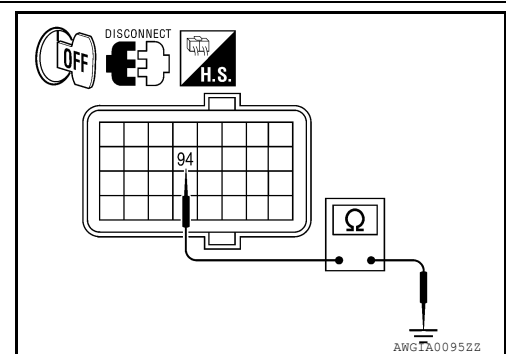

2. Turn ignition switch ON.
3. Check voltage between ECM connector E10 terminal 94 and ground.

| ECM | | Ground | Voltage (Approx.) |
|-----------|----------|--------|-------------------|
| Connector | Terminal | | |
| E10 | 94 | — | 0V |

Is the inspection result normal?

- YES >> GO TO 4.

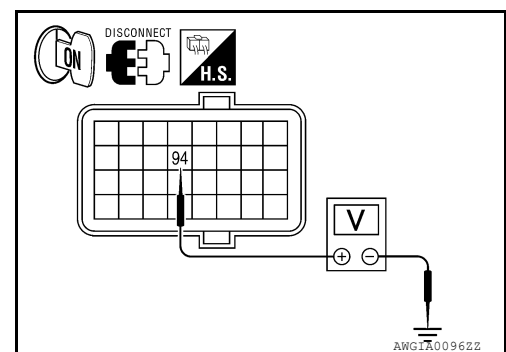

A
B
C
D
E
F
STC
H
I
J
K
L
M
N
O
P

ENGINE SPEED SIGNAL CIRCUIT

< DTC/CIRCUIT DIAGNOSIS >

NO >> Repair harness or connectors.

4. CHECK ENGINE SPEED SIGNAL (ECM SIDE)

1. Turn the ignition switch OFF.
2. Connect ECM connector E10.
3. Start the engine.
4. Check signal between ECM connector E10 terminal 94 and ground with oscilloscope.

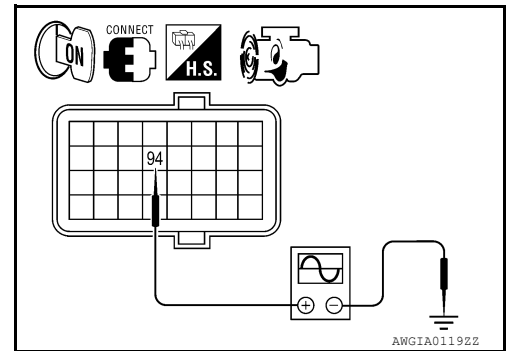

| ECM | | | Value (Approx.) |
|-----------|-------------|---|-----------------|
| Connector | Terminal | Condition | |
| E10 | 94 - Ground | Engine speed: At idle (Warm-up condition) | |
| | | Engine speed: Approx. 2,000 rpm (Warm-up condition) | |

Is the inspection result normal?

YES >> GO TO 5.

NO >> Replace ECM.

5. CHECK ENGINE SPEED SIGNAL (POWER STEERING CONTROL UNIT SIDE)

1. Turn the ignition switch OFF.
2. Connect power steering control unit harness connector.
3. Start the engine.
4. Check signal between power steering control unit harness connector M59 terminal 10 and ground with oscilloscope.

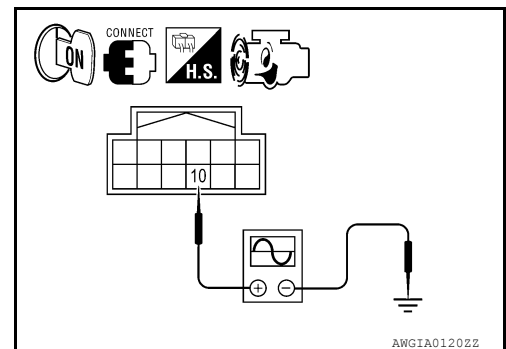

| Power steering control unit | | | Value (Approx.) |
|-----------------------------|-------------|---|-----------------|
| Connector | Terminal | Condition | |
| M59 | 10 - Ground | Engine speed: At idle (Warm-up condition) | |
| | | Engine speed: Approx. 2,000 rpm (Warm-up condition) | |

Is the inspection result normal?

ENGINE SPEED SIGNAL CIRCUIT

< DTC/CIRCUIT DIAGNOSIS >

YES >> GO TO 6.

NO >> Replace power steering control unit. Refer to [STC-21, "Removal and Installation"](#).

6. CHECK TERMINALS AND HARNESS CONNECTORS

1. Check power steering control unit pin terminals for damage or loose connection with harness connector.

2. Check ECM pin terminals for damage or loose connection with harness connector.

Is the inspection result normal?

YES >> Inspection End.

NO >> Repair or replace damaged parts.

A

B

C

D

E

F

STC

H

I

J

K

L

M

N

O

P

VEHICLE SPEED SIGNAL CIRCUIT

< DTC/CIRCUIT DIAGNOSIS >

VEHICLE SPEED SIGNAL CIRCUIT

Description

INFOID:000000007254752

Combination meter sends vehicle speed signal to power steering control unit.

Diagnosis Procedure

INFOID:000000007254753

Regarding Wiring Diagram information, refer to [STC-16, "Wiring Diagram"](#).

1. PERFORM COMBINATION METER SELF-DIAGNOSIS

Perform combination meter self-diagnosis.

Is any error system detected?

- YES >> Check the error system.
- NO >> GO TO 2.

2. CHECK HARNESS BETWEEN COMBINATION METER AND POWER STEERING CONTROL UNIT FOR OPEN

1. Turn the ignition switch OFF.
2. Disconnect combination meter connector.
3. Disconnect power steering control unit connector.
4. Check continuity between combination meter connector M24 (A) terminal 30 and power steering control unit connector M59 (B) terminal 8.

| Combination meter | | Power steering control unit | | Continuity |
|-------------------|----------|-----------------------------|----------|------------|
| Connector | Terminal | Connector | Terminal | |
| M24 (A) | 30 | M59 (B) | 8 | Yes |

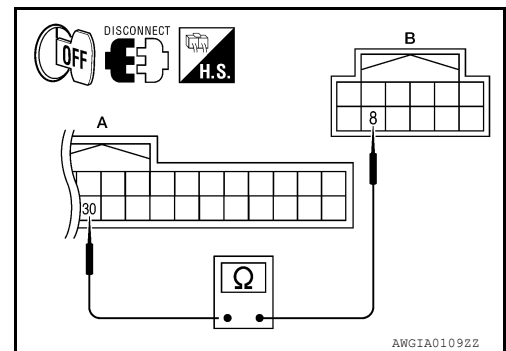

Is the inspection result normal?

- YES >> GO TO 3.
- NO >> Repair harness or connectors.

3. CHECK HARNESS BETWEEN COMBINATION METER AND POWER STEERING CONTROL UNIT FOR SHORT

1. Check continuity between combination meter connector M24 terminal 30 and ground.

| Combination meter | | Ground | Continuity |
|-------------------|----------|--------|------------|
| Connector | Terminal | | |
| M24 | 30 | — | No |

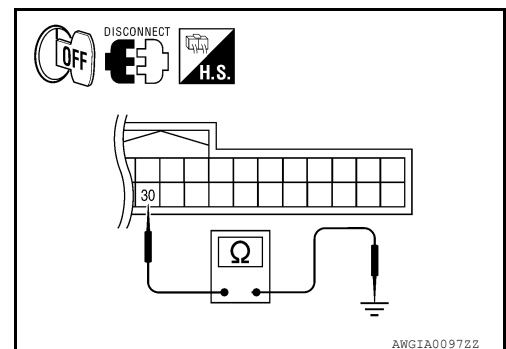

VEHICLE SPEED SIGNAL CIRCUIT

< DTC/CIRCUIT DIAGNOSIS >

2. Turn ignition switch ON.
3. Check voltage between combination meter connector M24 terminal 30 and ground.

| Combination meter | | Ground | Voltage (Approx.) |
|-------------------|----------|--------|-------------------|
| Connector | Terminal | | |
| M24 | 30 | — | 0V |

Is the inspection result normal?

- YES >> GO TO 4.
 NO >> Repair harness or connectors.

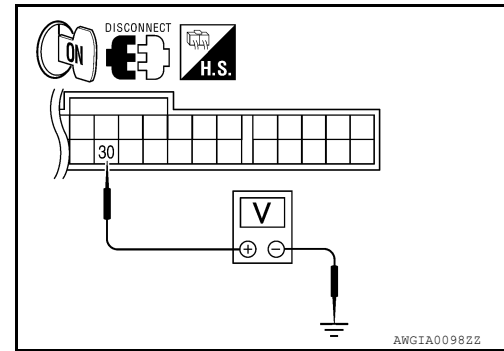

4. CHECK VEHICLE SPEED SIGNAL (COMBINATION METER SIDE)

1. Turn the ignition switch OFF.
2. Connect combination meter connector.
3. Check combination meter input/output standard values. Refer to [MWI-47, "Reference Value"](#).

Is the inspection result normal?

- YES >> GO TO 5.
 NO >> Replace combination meter. Refer to [MWI-121, "Removal and Installation"](#).

5. CHECK VEHICLE SPEED SIGNAL (POWER STEERING CONTROL UNIT SIDE)

1. Turn the ignition switch OFF.
2. Connect power steering control unit connector.
3. Start the engine.
4. Check signal between power steering control unit connector M59 terminal 8 and ground with oscilloscope.

| Power steering control unit | | | Value (Approx.) |
|-----------------------------|------------|---|-----------------|
| Connector | Terminal | Condition | |
| M59 | 8 - Ground | Vehicle speed: 40 km/h (25 MPH) CAUTION: Check air pressure of tire under standard condition. | |

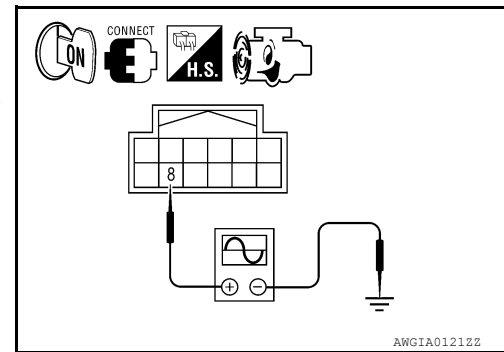

Is the inspection result normal?

- YES >> GO TO 6.
 NO >> Replace power steering control unit. Refer to [STC-21, "Removal and Installation"](#).

6. CHECK TERMINALS AND HARNESS CONNECTORS

1. Check power steering control unit pin terminals for damage or loose connection with harness connector.
2. Check combination meter pin terminals for damage or loose connection with harness connector.

Is the inspection result normal?

- YES >> Inspection End
 NO >> Repair or replace damaged parts.

POWER STEERING CONTROL UNIT

< ECU DIAGNOSIS INFORMATION >

ECU DIAGNOSIS INFORMATION

POWER STEERING CONTROL UNIT

Reference Value

INFOID:000000007254754

TERMINAL LAYOUT

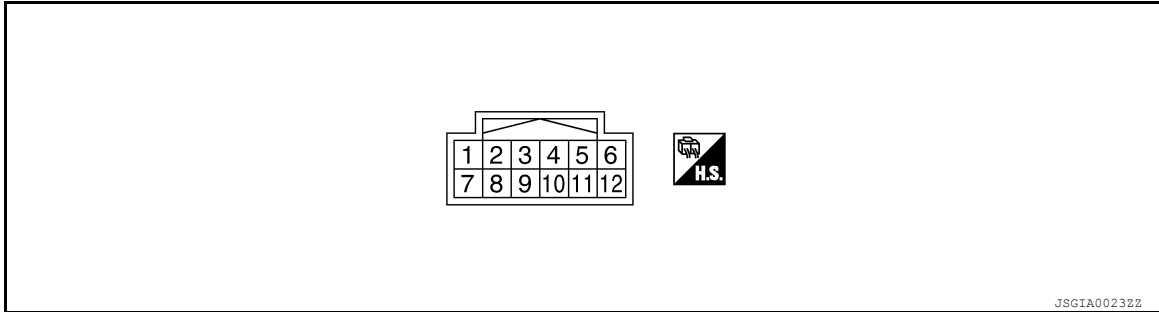

PHYSICAL VALUES

| Terminal No. | | Wire color | Description | | Condition | Value (Approx.) |
|--------------|--------|------------|---------------------------------------|--------------|--|---|
| + | - | | Signal name | Input/Output | | |
| 1 | Ground | R/Y | Power steering solenoid valve voltage | Output | Vehicle speed: 0 km/h (0 MPH) (Engine is running) | 4.4 - 6.6 V |
| | | | | | Vehicle speed: 100 km/h (62 MPH) | 2.5 - 3.7 V |
| 3 | Ground | G | Ignition power supply | Input | Ignition switch: ON | Battery voltage |
| | | | | | Ignition switch: OFF | 0 V |
| 5 | Ground | LG/W | Power steering solenoid valve ground | — | Always | 0 V |
| 6 | Ground | B | Ground | — | Always | 0 V |
| 8 | Ground | L/B | Vehicle speed signal | Input | Vehicle speed: 40 km/h (25 MPH) CAUTION: Check air pressure of tire under standard condition. | <p style="text-align: right;">ELF1080D</p> |
| 10 | Ground | V/W | Engine speed signal | Input | Engine speed: At idle (Warm-up condition) | <p style="text-align: right;">JSGIA01432Z</p> |
| | | | | | Engine speed: Approx. 2,000 RPM (Warm-up condition) | <p style="text-align: right;">PBIA3655J</p> |

CAUTION:

POWER STEERING CONTROL UNIT

< ECU DIAGNOSIS INFORMATION >

When using circuit tester or oscilloscope to measure voltage for inspection, be sure not to extend forcibly any connector terminals.

Fail Safe

INFOID:000000007254755

EPS system

- EPS system enters the fail-safe mode (that allows the steering force to be controlled without impairing the drive ability) if any of the input/output signals to/from EPS system (power steering control unit) deviate from the standard.

NOTE:

The system enters the fail-safe mode if the engine speed remains at 1,500 RPM or more for over 10 seconds while the vehicle is stopped. This is normal.

- The fail-safe function is cancelled when a vehicle speed signal of 2 km/h (1.2 MPH) or more is inputted or the key switch is turned OFF→ ON. EPS system restores the normal operation at that time.

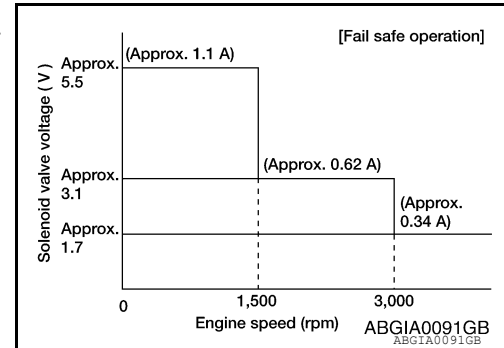

| Function | Warning lamp | DTC No. | Detection point (malfunction part) | Malfunction part and cause |
|--------------------|--------------|---------|------------------------------------|--|
| Fail-safe function | — | — | Vehicle speed signal | <ul style="list-style-type: none"> • Engine speed is 1,500 RPM or more and there is no vehicle speed signal input for over 10 seconds during vehicle travel. • Vehicle speed signal has abruptly dropped from 30 km/h (19 MPH) or more to 2 km/h (1.2 MPH) or less within 1.4 seconds. |

STC

ELECTRONICALLY CONTROLLED POWER STEERING SYSTEM

< WIRING DIAGRAM >

WIRING DIAGRAM

ELECTRONICALLY CONTROLLED POWER STEERING SYSTEM

Wiring Diagram

INFOID:000000007254756

ELECTRONICALLY CONTROLLED POWER STEERING SYSTEM

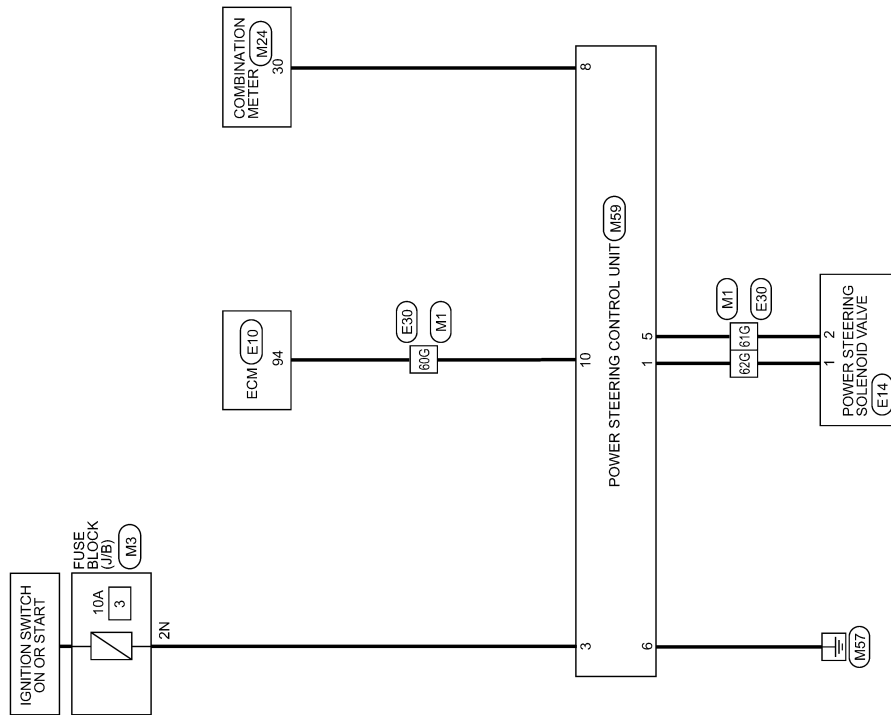

ELECTRONICALLY CONTROLLED POWER STEERING SYSTEM

< WIRING DIAGRAM >

ELECTRONICALLY CONTROLLED POWER STEERING SYSTEM CONNECTORS

| | |
|-----------------|--------------|
| Connector No. | M1 |
| Connector Name | WIRE TO WIRE |
| Connector Color | WHITE |

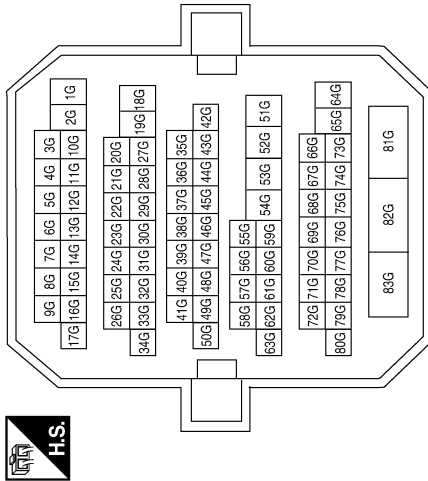

| Terminal No. | Color of Wire | Signal Name |
|--------------|---------------|-------------|
| 60G | V/W | - |
| 61G | LG/W | - |
| 62G | R/Y | - |

| | |
|-----------------|------------------|
| Connector No. | M3 |
| Connector Name | FUSE BLOCK (J/B) |
| Connector Color | WHITE |

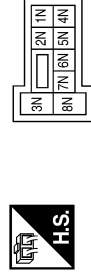

| Terminal No. | Color of Wire | Signal Name |
|--------------|---------------|-------------|
| 2N | G | - |

| | |
|-----------------|-------------------|
| Connector No. | M24 |
| Connector Name | COMBINATION METER |
| Connector Color | WHITE |

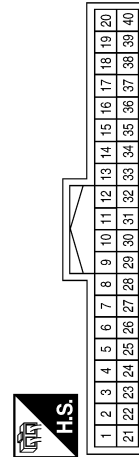

| Terminal No. | Color of Wire | Signal Name |
|--------------|---------------|-------------|
| 30 | L/B | 2P/R OUT |

| | |
|-----------------|-----------------------------|
| Connector No. | M59 |
| Connector Name | POWER STEERING CONTROL UNIT |
| Connector Color | WHITE |

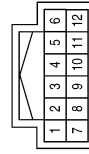

| Terminal No. | Color of Wire | Signal Name |
|--------------|---------------|-------------|
| 1 | R/Y | SOL |
| 2 | - | - |
| 3 | G | IGN |
| 4 | - | - |
| 5 | LG/W | SOL GND |
| 6 | B | GND |

| Terminal No. | Color of Wire | Signal Name |
|--------------|---------------|--------------------|
| 7 | - | - |
| 8 | L/B | VEHICLE SPEED (2P) |
| 9 | - | - |
| 10 | V/W | ENG TACHO |
| 11 | - | - |
| 12 | - | - |

A B C D E F H I J K L M N O P

STC

ELECTRONICALLY CONTROLLED POWER STEERING SYSTEM

< WIRING DIAGRAM >

| | |
|-----------------|-------|
| Connector No. | E10 |
| Connector Name | ECM |
| Connector Color | BLACK |

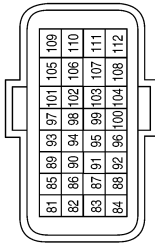

| Terminal No. | Color of Wire | Signal Name |
|--------------|---------------|---------------|
| 94 | GR | TACHO (CABIN) |

| | |
|-----------------|-------------------------------|
| Connector No. | E14 |
| Connector Name | POWER STEERING SOLENOID VALVE |
| Connector Color | BLACK |



| Terminal No. | Color of Wire | Signal Name |
|--------------|---------------|-------------|
| 1 | V | POWER |
| 2 | LG | GND |

| | |
|-----------------|--------------|
| Connector No. | E30 |
| Connector Name | WIRE TO WIRE |
| Connector Color | WHITE |

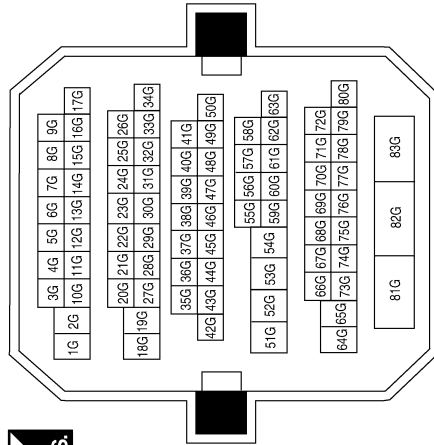

| Terminal No. | Color of Wire | Signal Name |
|--------------|---------------|-------------|
| 60G | GR | - |
| 61G | LG | - |
| 62G | V | - |

UNBALANCE STEERING WHEEL TURNING FORCE (TORQUE VARIATION)

< SYMPTOM DIAGNOSIS >

SYMPTOM DIAGNOSIS

UNBALANCE STEERING WHEEL TURNING FORCE (TORQUE VARIATION)

Description

INFOID:000000007254757

- Hard steering when fully turning the steering wheel.
- Light steering when driving at a high speed.

Diagnosis Procedure

INFOID:000000007254758

1. CHECK SYSTEM FOR POWER SUPPLY AND GROUND

Perform trouble diagnosis for power supply and ground circuit. Refer to [STC-6, "Diagnosis Procedure"](#).

Is the inspection result normal?

YES >> GO TO 2.

NO >> Repair or replace damaged parts.

2. CHECK SYSTEM FOR VEHICLE SPEED SIGNAL

Perform trouble diagnosis for vehicle speed signal. Refer to [STC-12, "Diagnosis Procedure"](#).

Is the inspection result normal?

YES >> GO TO 3.

NO >> Repair or replace damaged parts.

3. CHECK SYSTEM FOR ENGINE SPEED SIGNAL

Perform trouble diagnosis for engine speed signal. Refer to [STC-9, "Diagnosis Procedure"](#).

Is the inspection result normal?

YES >> GO TO 4.

NO >> Repair or replace damaged parts.

4. CHECK SYSTEM FOR POWER STEERING SOLENOID VALVE

Perform trouble diagnosis for power steering solenoid valve. Refer to [STC-7, "Diagnosis Procedure"](#).

Is the inspection result normal?

YES >> Perform the symptom diagnosis for the steering system. Refer to [ST-8, "NVH Troubleshooting Chart"](#).

NO >> Repair or replace damaged parts.

PRECAUTIONS

< PRECAUTION >

PRECAUTION

PRECAUTIONS

Precaution for Supplemental Restraint System (SRS) "AIR BAG" and "SEAT BELT PRE-TENSIONER"

INFOID:000000007254759

The Supplemental Restraint System such as "AIR BAG" and "SEAT BELT PRE-TENSIONER", used along with a front seat belt, helps to reduce the risk or severity of injury to the driver and front passenger for certain types of collision. This system includes seat belt switch inputs and dual stage front air bag modules. The SRS system uses the seat belt switches to determine the front air bag deployment, and may only deploy one front air bag, depending on the severity of a collision and whether the front occupants are belted or unbelted. Information necessary to service the system safely is included in the SR and SB section of this Service Manual.

WARNING:

- To avoid rendering the SRS inoperative, which could increase the risk of personal injury or death in the event of a collision which would result in air bag inflation, all maintenance must be performed by an authorized NISSAN/INFINITI dealer.
- Improper maintenance, including incorrect removal and installation of the SRS, can lead to personal injury caused by unintentional activation of the system. For removal of Spiral Cable and Air Bag Module, see the SR section.
- Do not use electrical test equipment on any circuit related to the SRS unless instructed to in this Service Manual. SRS wiring harnesses can be identified by yellow and/or orange harnesses or harness connectors.

PRECAUTIONS WHEN USING POWER TOOLS (AIR OR ELECTRIC) AND HAMMERS

WARNING:

- When working near the Airbag Diagnosis Sensor Unit or other Airbag System sensors with the Ignition ON or engine running, DO NOT use air or electric power tools or strike near the sensor(s) with a hammer. Heavy vibration could activate the sensor(s) and deploy the air bag(s), possibly causing serious injury.
- When using air or electric power tools or hammers, always switch the Ignition OFF, disconnect the battery, and wait at least 3 minutes before performing any service.

EPS CONTROL UNIT

< UNIT REMOVAL AND INSTALLATION >

UNIT REMOVAL AND INSTALLATION

EPS CONTROL UNIT

Removal and Installation

INFOID:000000007254760

REMOVAL

1. Disconnect negative battery terminal. Refer to [PG-67. "Removal and Installation \(Battery\)"](#).
2. Remove audio/navigation unit. Refer to [AV-66. "Removal and Installation"](#) (BASE AUDIO), [AV-159. "Removal and Installation"](#) (BOSE W/MONOCROME DISPLAY), [AV-322. "Removal and Installation"](#) (BOSE W/COLOR DISPLAY), [AV-490. "Removal and Installation"](#) (BOSE W/COLOR DISPLAY W/NAVIGATION).
3. Remove automatic drive position control unit (if equipped). Refer to [ADP-172. "Removal and Installation"](#).
4. Remove EPS control unit (1) from the bracket.
5. Disconnect EPS control unit connector (A) and remove the EPS control unit (1).

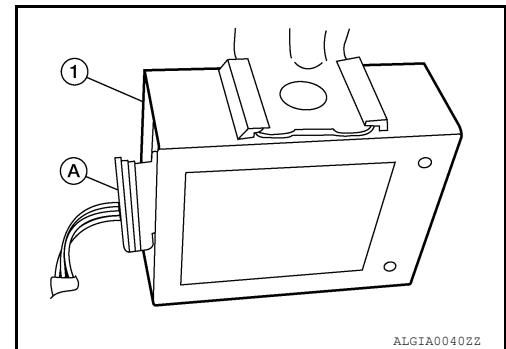

INSTALLATION

Installation is in the reverse order of removal.