

A
STR
C
D
E
F
G
H
I
J
K
L
M
N
O
P

SECTION STR

STARTING SYSTEM

CONTENTS

VQ35DE	SYMPTOM DIAGNOSIS	16
BASIC INSPECTION	STARTING SYSTEM	16
	Symptom Table	16
DIAGNOSIS AND REPAIR WORKFLOW	PRECAUTION	17
Work Flow (With GR8-1200 NI)	PRECAUTIONS	17
Work Flow (Without GR8-1200 NI)	Precaution for Supplemental Restraint System (SRS) "AIR BAG" and "SEAT BELT PRE-TENSIONER"	17
SYSTEM DESCRIPTION	PREPARATION	18
STARTING SYSTEM	PREPARATION	18
System Diagram	Special Service Tool	18
System Description	Commercial Service Tools	18
Component Description	REMOVAL AND INSTALLATION	19
DTC/CIRCUIT DIAGNOSIS	STARTER MOTOR	19
B TERMINAL CIRCUIT	Removal and Installation	19
Description	SERVICE DATA AND SPECIFICATIONS (SDS)	20
Diagnosis Procedure	STARTER MOTOR	20
S CONNECTOR CIRCUIT	Starter	20
Description		
Diagnosis Procedure		
WIRING DIAGRAM		
STARTING SYSTEM		
Wiring Diagram		

BASIC INSPECTION

DIAGNOSIS AND REPAIR WORKFLOW

Work Flow (With GR8-1200 NI)

INFOID:000000008809461

STARTING SYSTEM DIAGNOSIS WITH GR8-1200 NI

To test the starting system, use the following special service tool:

- GR8-1200 NI Multitasking battery and electrical diagnostic station

NOTE:

Refer to the diagnostic station Instruction Manual for proper starting system diagnosis procedures.

DIAGNOSIS AND REPAIR WORKFLOW

< BASIC INSPECTION >

[VQ35DE]

OVERALL SEQUENCE

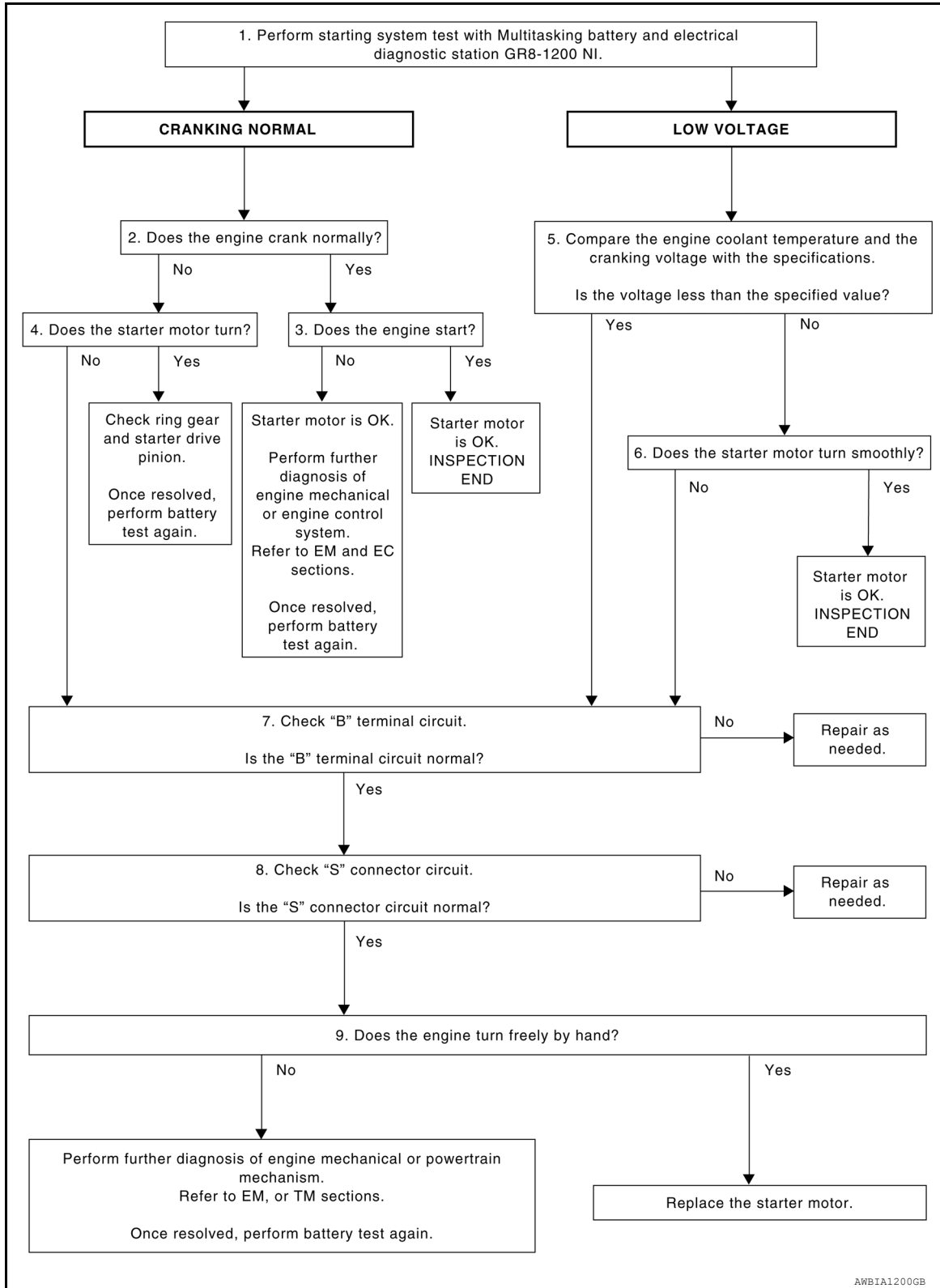

DETAILED FLOW

NOTE:

To ensure a complete and thorough diagnosis, the battery, starter motor and generator test segments must be done as a set from start to finish.

1. DIAGNOSIS WITH MULTITASKING BATTERY AND ELECTRICAL DIAGNOSTIC STATION GR8-1200 NI

DIAGNOSIS AND REPAIR WORKFLOW

[VQ35DE]

< BASIC INSPECTION >

Perform the starting system test with Multitasking battery and electrical diagnostic station GR8-1200 NI. For details and operating instructions, refer to diagnostic station Instruction Manual.

Test result

CRANKING NORMAL>>GO TO 2.

LOW VOLTAGE>>GO TO 5.

CHARGE BATTERY>>Perform the slow battery charging procedure. (Initial rate of charge is 10A for 12 hours.) Perform battery test again. Refer to diagnostic station instruction manual.

REPLACE BATTERY>>Before replacing battery, clean the battery cable clamps and battery posts. Perform battery test again. Refer to diagnostic station instruction manual. If second test result is "REPLACE BATTERY", then do so. Perform battery test again to confirm repair.

2. CRANKING CHECK

Check that the starter motor operates properly.

Does the engine crank normally?

YES >> GO TO 3.

NO >> GO TO 4.

3. ENGINE START CHECK

Check that the engine starts.

Does the engine start?

YES >> Inspection End.

NO >> Perform further diagnosis of engine mechanical or engine control system. Refer to EM and EC sections. Once resolved, perform battery test again.

4. STARTER MOTOR ACTIVATION

Check that the starter motor operates.

Does the starter motor turn?

YES >> Check ring gear and starter motor drive pinion. Once resolved, perform battery test again.

NO >> GO TO 7.

5. COMPARISON BETWEEN ENGINE COOLANT AND CRANKING VOLTAGE

Compare the engine coolant temperature and verify the cranking voltage is within specifications.

Minimum Specification of Cranking Voltage Referencing Coolant Temperature

Engine coolant temperature [°C (°F)]	Voltage [V]
-30 to -20 (-22 to -4)	8.6
-19 to -10 (-2 to 14)	9.1
-9 to 0 (16 to 32)	9.5
More than 1 (More than 34)	9.9

Is the voltage less than the specified value?

YES >> GO TO 7.

NO >> GO TO 6.

6. STARTER OPERATION

Check the starter operation.

Does the starter motor turn smoothly?

YES >> Inspection End.

NO >> GO TO 7.

7. "B" TERMINAL CIRCUIT INSPECTION

Check "B" terminal circuit. Refer to [STR-9, "Diagnosis Procedure"](#).

Is "B" terminal circuit normal?

YES >> GO TO 8.

NO >> Repair as needed.

8. "S" CONNECTOR CIRCUIT INSPECTION

Check "S" connector circuit. Refer to [STR-11, "Diagnosis Procedure"](#).

DIAGNOSIS AND REPAIR WORKFLOW

[VQ35DE]

< BASIC INSPECTION >

Is "S" connector circuit normal?

YES >> GO TO 9.

NO >> Repair as needed.

9. ENGINE ROTATION STATUS

Check that the engine can be rotated by hand.

Does the engine turn freely by hand?

YES >> Replace starter motor.

NO >> Perform further diagnosis of engine mechanical or powertrain mechanism. Once resolved, perform battery test again using Multitasking battery and electrical diagnostic station GR8-1200 NI. Refer to the diagnostic station Instruction Manual for proper testing procedures.

A

STR

C

D

E

F

G

H

I

J

K

L

M

N

O

P

DIAGNOSIS AND REPAIR WORKFLOW

< BASIC INSPECTION >

[VQ35DE]

Work Flow (Without GR8-1200 NI)

INFOID:000000008809462

OVERALL SEQUENCE

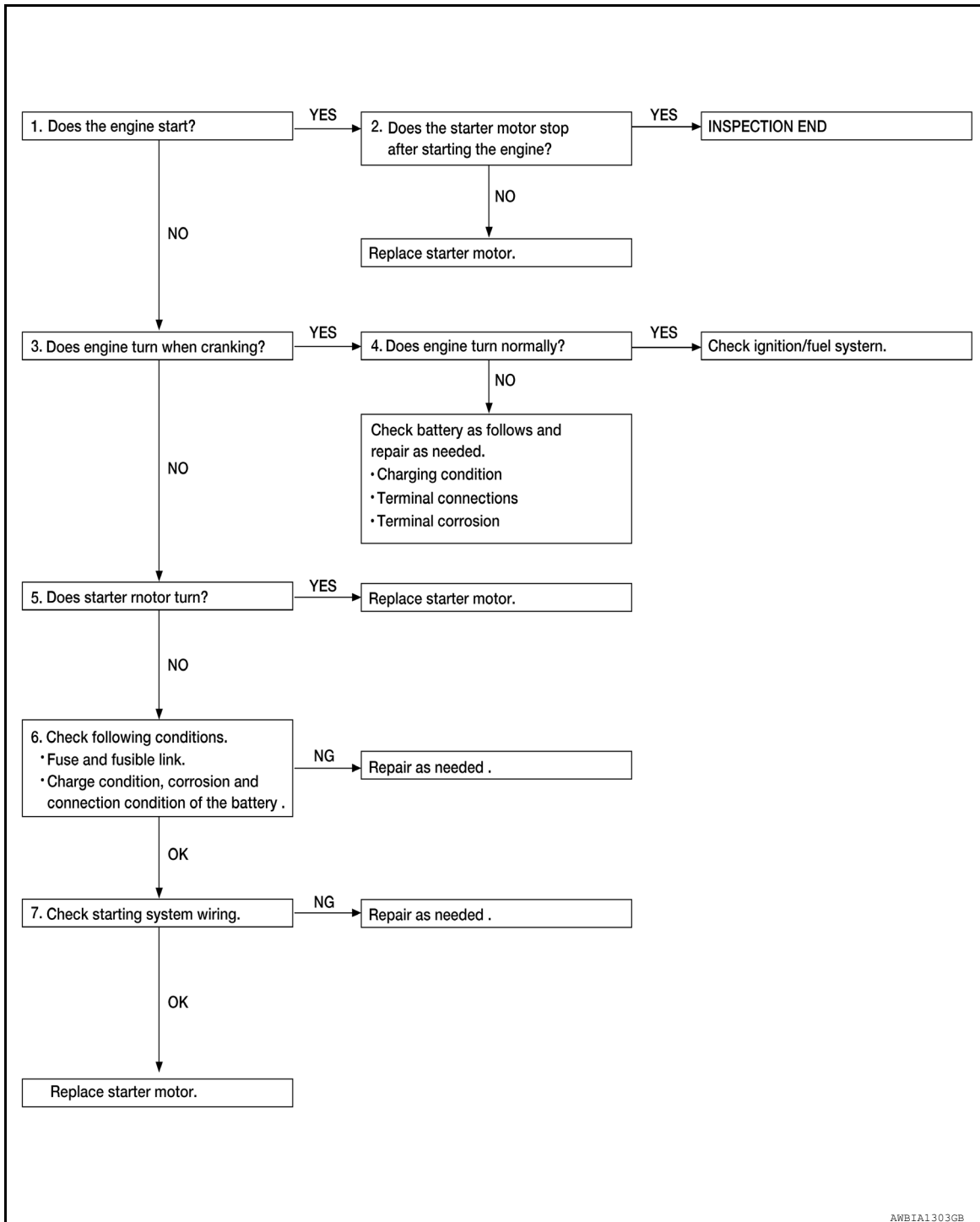

DETAILED FLOW

NOTE:

If any malfunction is found, immediately disconnect the battery cable from the negative terminal.

1. CHECK ENGINE START

Crank the engine and check that the engine starts.

Does the engine start?

YES >> GO TO 2.

NO >> GO TO 3.

DIAGNOSIS AND REPAIR WORKFLOW

< BASIC INSPECTION >

[VQ35DE]

2. CHECK THAT THE STARTER MOTOR STOPS

Check that the starter motor stops after starting the engine.

Does the starter motor stop?

YES >> Inspection End.

NO >> Replace starter motor. Refer to [STR-19. "Removal and Installation"](#).

3. CHECK THAT THE ENGINE TURNS WHEN CRANKING

Check that the engine turns when cranking.

Does engine turn when cranking?

YES >> GO TO 4.

NO >> GO TO 5.

4. CHECK THE ENGINE SPEED WHEN CRANKING

Check that the engine speed is not low when cranking.

Does engine turn normally?

YES >> Check ignition/fuel system.

NO >> Check charge condition, corrosion and connection condition of the battery. Refer to [PG-2. "How to Handle Battery"](#).

5. CHECK STARTER MOTOR ACTIVATION

Check that the starter motor runs at cranking.

Does starter motor turn?

YES >> Replace starter motor. Refer to [STR-19. "Removal and Installation"](#).

NO >> GO TO 6.

6. CHECK POWER SUPPLY CIRCUIT

Check the following conditions:

- Fuse and fusible link
- Charge condition, corrosion and connection of the battery.

Are these inspection results normal?

YES >> GO TO 7.

NO >> Repair as needed.

7. CHECK STARTING SYSTEM WIRING

Check the following:

- "B" terminal circuit. Refer to [STR-9. "Diagnosis Procedure"](#).
- "S" terminal circuit. Refer to [STR-11. "Diagnosis Procedure"](#).

Are the inspection results normal?

YES >> Replace starter motor. Refer to [STR-19. "Removal and Installation"](#).

NO >> Repair as needed.

A

STR

C

D

E

F

G

H

I

J

K

L

M

N

O

P

STARTING SYSTEM

< SYSTEM DESCRIPTION >

[VQ35DE]

SYSTEM DESCRIPTION

STARTING SYSTEM

System Diagram

INFOID:000000007255932

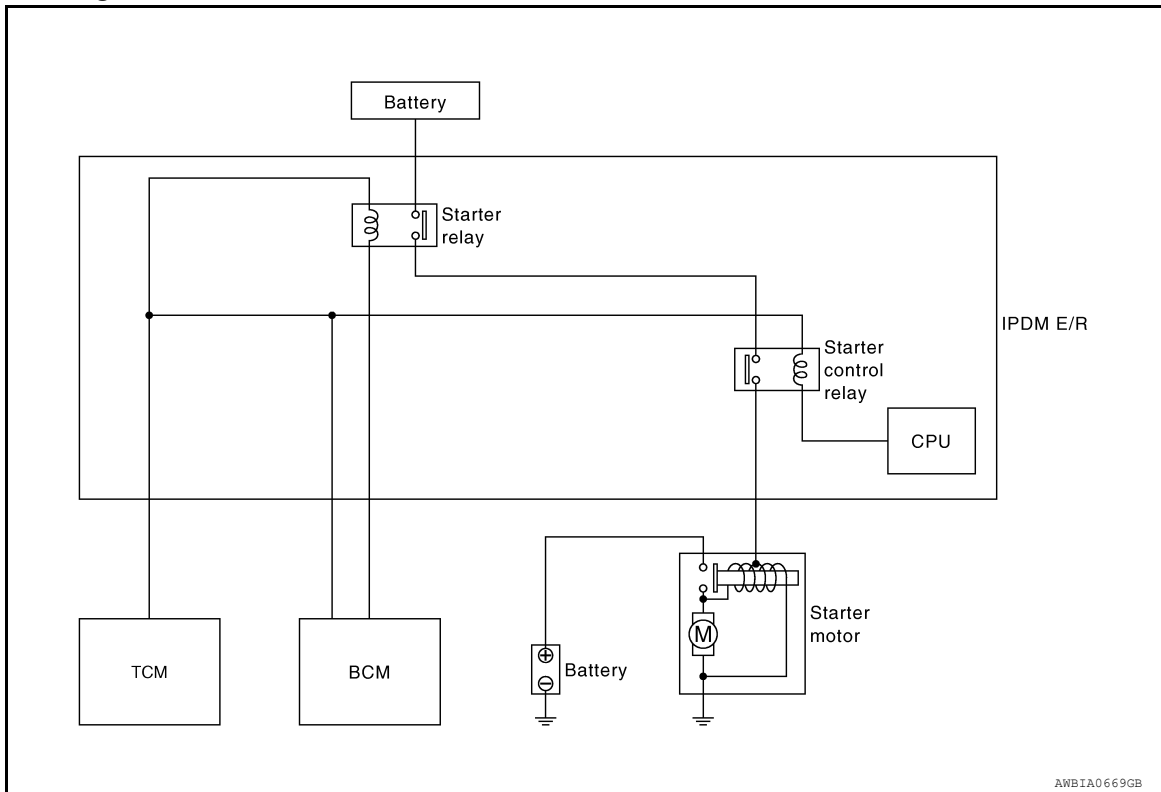

AWBIA0669GB

System Description

INFOID:000000007255933

The starter motor plunger closes and provides a closed circuit between the battery and the starter motor. The starter motor is grounded to the cylinder block. With power and ground supplied, the starter motor operates.

Component Description

INFOID:000000007255934

Component part	Description
TCM	TCM supplies power to the starter relay and starter control relay inside IPDM E/R when the selector lever is shifted to the P or N position.
BCM	BCM controls the starter relay inside IPDM E/R.
IPDM E/R	CPU inside IPDM E/R controls the starter control relay.
Starter motor	The starter motor plunger closes and the motor is supplied with battery power, which in turn cranks the engine, when the "S" terminal is supplied with electric power.

DTC/CIRCUIT DIAGNOSIS

B TERMINAL CIRCUIT

Description

INFOID:000000007255935

The "B" terminal is constantly supplied with battery power.

Diagnosis Procedure

INFOID:000000007255936

Regarding Wiring Diagram information, refer to [STR-12. "Wiring Diagram"](#).

CAUTION:

Perform diagnosis under the condition that the engine cannot start by the following procedure.

1. Remove fuel pump fuse.
2. Crank or start the engine (where possible) until the fuel pressure is depleted.

1. CHECK TERMINAL B POWER SUPPLY VOLTAGE

1. Turn ignition switch OFF.
2. Make sure that starter motor connector F27 terminal B connection is clean and tight.
3. Check voltage between starter motor connector F27 terminal B and ground.

B - ground

Battery voltage

Is there battery voltage present?

- YES >> GO TO 2
 NO >> Check harness between battery and starter motor for open circuit.

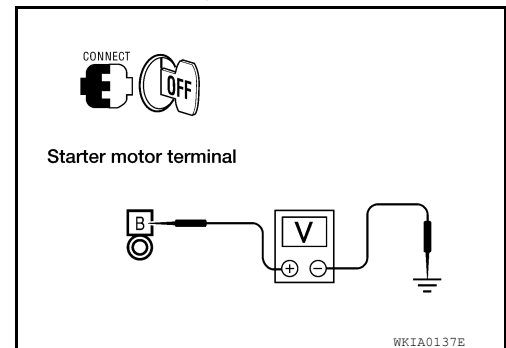

2. CHECK BATTERY CABLE (VOLTAGE DROP TEST)

1. Shift CVT selector lever to "P" or "N" position.
2. Check voltage between battery positive terminal and starter motor connector F27 terminal B while cranking the engine.

While cranking the engine

Terminal B - B+ terminal

Less than 0.5V

Is the voltage drop less than 0.5V?

- YES >> GO TO 3
 NO >> Check harness between the battery and the starter motor for high resistance.

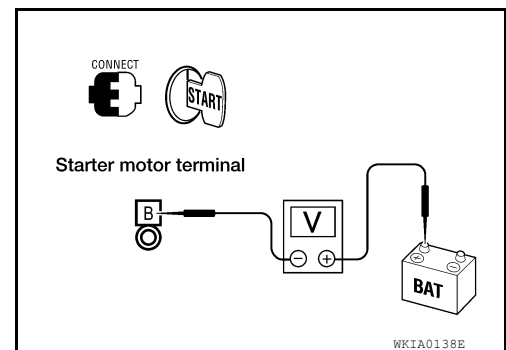

3. CHECK GROUND CIRCUIT STATUS (VOLTAGE DROP TEST)

1. Shift CVT selector lever to "P" or "N" position.

B TERMINAL CIRCUIT

[VQ35DE]

< DTC/CIRCUIT DIAGNOSIS >

2. Check voltage between starter motor case and battery negative terminal while cranking the engine.

While cranking the engine

Starter case - B- terminal

Less than 0.2V

Is the voltage drop less than 0.2V?

- YES >> Terminal B circuit is OK. Further inspection is necessary.
Refer to [STR-2. "Work Flow \(With GR8-1200 NI\)"](#) or
[STR-6. "Work Flow \(Without GR8-1200 NI\)"](#).
- NO >> Check the starter motor case to engine mounting for high resistance.

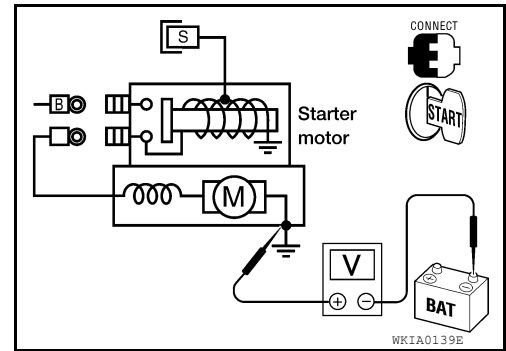

S CONNECTOR CIRCUIT

< DTC/CIRCUIT DIAGNOSIS >

[VQ35DE]

S CONNECTOR CIRCUIT

Description

INFOID:000000007255937

The starter motor magnetic switch is supplied with power when the ignition switch is turned to the START position while the selector lever is in the P or N position.

STR

Diagnosis Procedure

INFOID:000000007255938

Regarding Wiring Diagram information, refer to [STR-12, "Wiring Diagram"](#).

CAUTION:

Perform diagnosis under the condition that engine cannot start by the following procedure.

1. Remove fuel pump fuse.
2. Crank or start the engine (where possible) until the fuel pressure is released.

1. CHECK "S" CONNECTOR CIRCUIT

1. Turn ignition switch OFF.
2. Disconnect starter motor connector F28.
3. Shift CVT selector lever to "P" or "N" position.
4. Check voltage between starter motor harness connector F28 terminal S and ground with the ignition in START.

With ignition switch in START
S - ground Battery voltage

Is battery voltage present?

YES >> "S" circuit is OK. Further inspection is necessary. Refer to [STR-2, "Work Flow \(With GR8-1200 NI\)"](#) or [STR-6, "Work Flow \(Without GR8-1200 NI\)"](#).

NO >> GO TO 2

2. CHECK CONNECTOR

1. Turn ignition switch OFF.
2. Check the following terminals and connectors for damage, bent pins and loose connections.
 - IPDM E/R harness connector F10
 - Starter motor harness connector F28

Is the inspection result normal?

YES >> GO TO 3

NO >> Repair the terminal and connector.

3. CHECK HARNESS CONTINUITY (OPEN/SHORT CIRCUIT)

1. Disconnect the following harness connectors.
 - IPDM E/R connector F10
 - Starter motor connector F28
2. Check continuity between starter motor harness connector F28 terminal S and IPDM E/R harness connector F10 terminal 80.

S - 80 Continuity exists

Is the inspection result normal?

YES >> Further inspection is necessary. Refer to [STR-2, "Work Flow \(With GR8-1200 NI\)"](#) or [STR-6, "Work Flow \(Without GR8-1200 NI\)"](#).

NO >> Repair the harness.

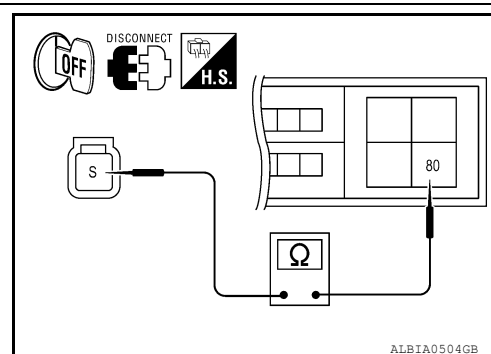
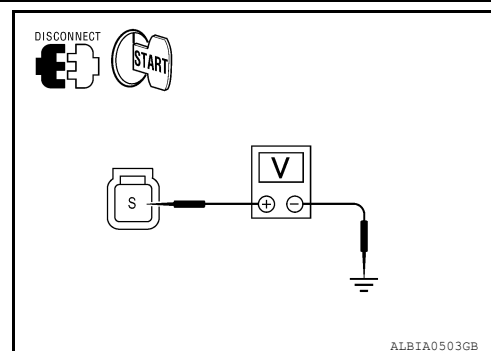

STARTING SYSTEM

< WIRING DIAGRAM >

[VQ35DE]

WIRING DIAGRAM

STARTING SYSTEM

Wiring Diagram

INFOID:000000007255939

STARTING SYSTEM

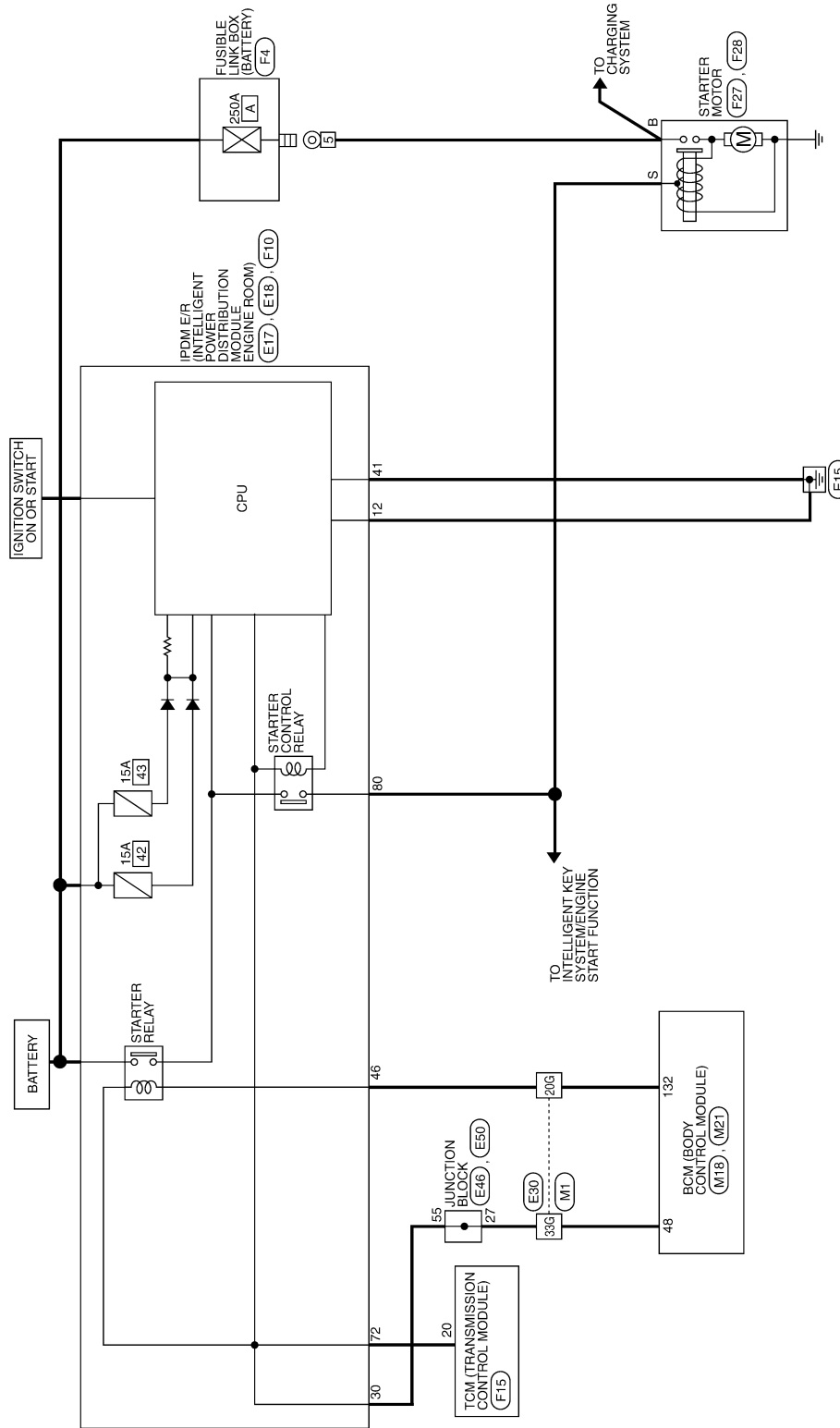

ABBWA0697GB

STARTING SYSTEM CONNECTORS

Connector No.	M1
Connector Name	WIRE TO WIRE
Connector Color	WHITE

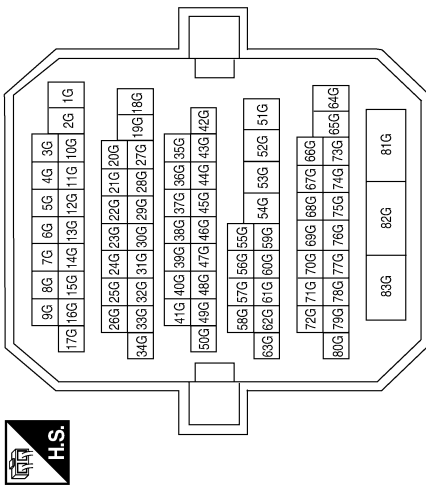

39	38	37	36	35	34	33	32	31	30	29	28	27	26	25	24	23	22	21	20
59	58	57	56	55	54	53	52	51	50	49	48	47	46	45	44	43	42	41	40

Terminal No.	Color of Wire	Signal Name
48	R/G	SHIFT N/P/NEUTRAL SW

Terminal No.	Color of Wire	Signal Name
20G	R	-
33G	R/G	-

Connector No.	M18
Connector Name	BCM (BODY CONTROL MODULE)
Connector Color	GREEN

Connector No.	M21
Connector Name	BCM (BODY CONTROL MODULE)
Connector Color	GRAY



131	130	129	128	127	126	125	124	123	122	121	120	119	118	117	116	115	114	113	112
151	150	149	148	147	146	145	144	143	142	141	140	139	138	137	136	135	134	133	132

Terminal No.	Color of Wire	Signal Name
132	R	ST RELAY OUTPUT

Connector No.	E17
Connector Name	IPDM E/R (INTELLIGENT POWER DISTRIBUTION MODULE ENGINE ROOM)
Connector Color	WHITE



42	41	40	39
46	45	44	43

Terminal No.	Color of Wire	Signal Name
41	B	GND (SIGNAL)
46	BR	START CONT

STARTING SYSTEM

< WIRING DIAGRAM >

[VQ35DE]

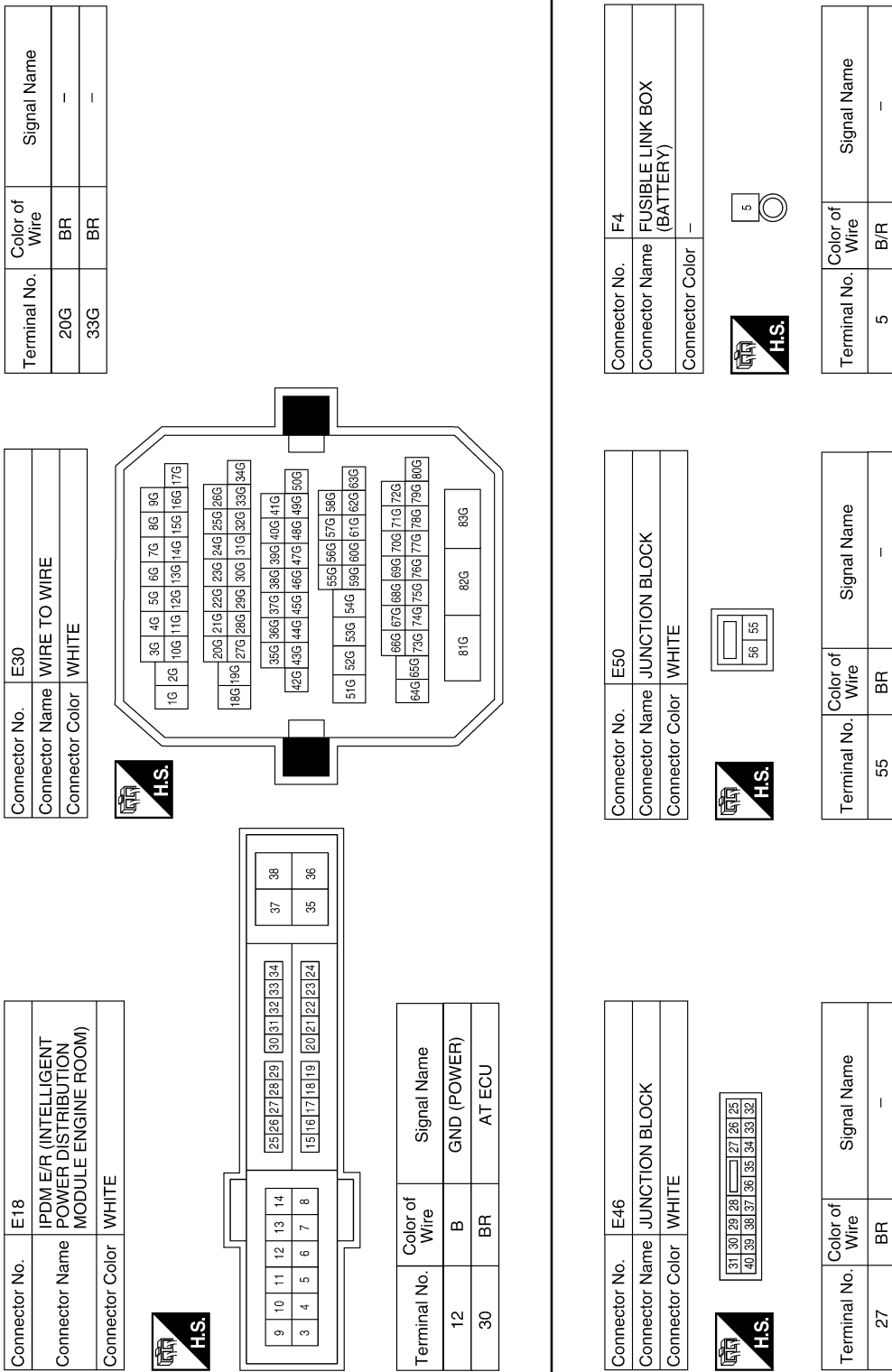

ABBIA1196GB

STARTING SYSTEM

< WIRING DIAGRAM >

[VQ35DE]

Connector No.	F15
Connector Name	TCM (TRANSMISSION CONTROL MODULE)
Connector Color	BLACK

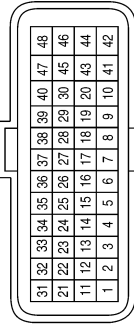

Terminal No.	Color of Wire	Signal Name
20	R/B	ST RLY

Terminal No.	Color of Wire	Signal Name
72	R/B	NP SW
80	B	STARTER MOTOR

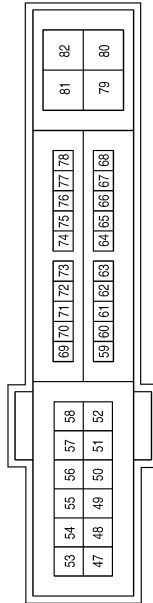

Connector No.	F28
Connector Name	STARTER MOTOR
Connector Color	GRAY



Terminal No.	Color of Wire	Signal Name
S	B	START

Connector No.	F27
Connector Name	STARTER MOTOR
Connector Color	-



Terminal No.	Color of Wire	Signal Name
B	B/R	BATT

ABBIA0852GB

A

STR

C

D

E

F

G

H

I

J

K

L

M

N

O

P

SYMPTOM DIAGNOSIS

STARTING SYSTEM

Symptom Table

INFOID:000000007255940

Symptom	Reference
No normal cranking	Refer to STR-2. "Work Flow (With GR8-1200 NI)" or STR-6. "Work Flow (Without GR8-1200 NI)" .
Starter motor does not rotate	

PRECAUTION

PRECAUTIONS

Precaution for Supplemental Restraint System (SRS) "AIR BAG" and "SEAT BELT PRE-TENSIONER"

INFOID:000000007255941

The Supplemental Restraint System such as "AIR BAG" and "SEAT BELT PRE-TENSIONER", used along with a front seat belt, helps to reduce the risk or severity of injury to the driver and front passenger for certain types of collision. This system includes seat belt switch inputs and dual stage front air bag modules. The SRS system uses the seat belt switches to determine the front air bag deployment, and may only deploy one front air bag, depending on the severity of a collision and whether the front occupants are belted or unbelted. Information necessary to service the system safely is included in the SR and SB section of this Service Manual.

WARNING:

- To avoid rendering the SRS inoperative, which could increase the risk of personal injury or death in the event of a collision which would result in air bag inflation, all maintenance must be performed by an authorized NISSAN/INFINITI dealer.
- Improper maintenance, including incorrect removal and installation of the SRS, can lead to personal injury caused by unintentional activation of the system. For removal of Spiral Cable and Air Bag Module, see the SR section.
- Do not use electrical test equipment on any circuit related to the SRS unless instructed to in this Service Manual. SRS wiring harnesses can be identified by yellow and/or orange harnesses or harness connectors.

PRECAUTIONS WHEN USING POWER TOOLS (AIR OR ELECTRIC) AND HAMMERS

WARNING:

- When working near the Airbag Diagnosis Sensor Unit or other Airbag System sensors with the Ignition ON or engine running, DO NOT use air or electric power tools or strike near the sensor(s) with a hammer. Heavy vibration could activate the sensor(s) and deploy the air bag(s), possibly causing serious injury.
- When using air or electric power tools or hammers, always switch the Ignition OFF, disconnect the battery, and wait at least 3 minutes before performing any service.

Precaution for Power Generation Voltage Variable Control System

CAUTION:

For this model, the battery current sensor that is installed to the battery cable at the negative terminal measures the charging/discharging current of the battery, and performs various controls. If the electrical component or the ground wire is connected directly to the battery terminal, the current other than that being measured with the battery current sensor is charging to or discharging from the battery. This condition causes the malfunction of the control, and then the battery discharge may occur. Do not connect the electrical component or the ground wire directly to the battery terminal.

A
STR
C
D
E
F
G
H
I
J
K
L
M
N
O
P

PREPARATION

< PREPARATION >

[VQ35DE]

PREPARATION

PREPARATION

Special Service Tool

INFOID:000000007255942

The actual shapes of Kent-Moore tools may differ from those of special service tools illustrated here.

Tool number (Kent-Moore No.) Tool name	Description
<p>— (—) Model GR8-1200 NI Multitasking battery and electrical diagnostic station</p>  <p style="text-align: right; font-size: small;">AWIIA12392Z</p>	<p>Tests batteries, starting and charging systems and charges batteries. For operating instructions, refer to diagnostic station instruction manual.</p>

Commercial Service Tools

INFOID:000000007255943

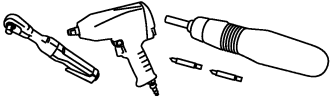
Tool name	Description
<p>Power tools</p>  <p style="text-align: right; font-size: small;">PIIB1407E</p>	<p>Loosening nuts, screws and bolts</p>

STARTER MOTOR

< REMOVAL AND INSTALLATION >

[VQ35DE]

REMOVAL AND INSTALLATION

STARTER MOTOR

Removal and Installation

INFOID:000000007255944

STR

REMOVAL

1. Remove the battery tray. Refer to [PG-68. "Removal and Installation \(Battery Tray\)"](#).
2. Disconnect the battery cable (A) and starter harness connector.
3. Remove the starter bolts, then remove the starter.

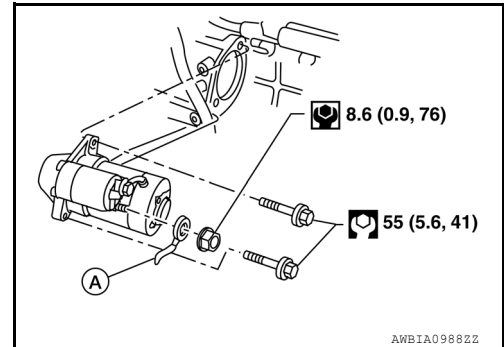

INSTALLATION

Installation is in the reverse order of removal.

CAUTION:

Tighten cable (A) nut carefully.

Reset electronic systems as necessary. Refer to [PG-5. "ADDITIONAL SERVICE WHEN REMOVING BATTERY NEGATIVE TERMINAL : Special Repair Requirement"](#).

STARTER MOTOR

< SERVICE DATA AND SPECIFICATIONS (SDS)

[VQ35DE]

SERVICE DATA AND SPECIFICATIONS (SDS)

STARTER MOTOR

Starter

INFOID:000000007255945

Application		VQ35DE
		CVT model
Type*		Mitsubishi M000TA0072
		Reduction gear type
System voltage		12V
No-load	Terminal voltage	11V
	Current	Less than 90A
	Revolution	More than 2,400 rpm

*: Always check with the Parts Department for the latest parts information.