

A
B
C

SECTION FAX

FRONT AXLE

FAX

CONTENTS

PRECAUTION	2	REMOVAL AND INSTALLATION	7	F
PRECAUTIONS	2	FRONT WHEEL HUB	7	
Precaution for Supplemental Restraint System (SRS) "AIR BAG" and "SEAT BELT PRE-TENSIONER"	2	Removal and Installation	7	G
Precautions for Drive Shaft	2	FRONT DRIVE SHAFT	9	
PREPARATION	3	Removal and Installation (Left Side)	9	H
PREPARATION	3	Removal and Installation (Right Side)	10	
Special Service Tool	3	UNIT DISASSEMBLY AND ASSEMBLY ...	13	
Commercial Service Tool	3	FRONT DRIVE SHAFT	13	I
SYMPTOM DIAGNOSIS	4	Disassembly and Assembly (Left Side)	13	
NOISE, VIBRATION, AND HARSHNESS (NVH) TROUBLESHOOTING	4	Disassembly and Assembly (Right Side)	19	J
NVH Troubleshooting Chart	4	SERVICE DATA AND SPECIFICATIONS (SDS)	26	
PERIODIC MAINTENANCE	5	SERVICE DATA AND SPECIFICATIONS (SDS)	26	K
FRONT WHEEL HUB	5	Wheel Bearing	26	L
Inspection	5	Drive Shaft	26	
FRONT DRIVE SHAFT	6	Dynamic Damper	26	M
Inspection	6	Boot Bands	27	

PRECAUTIONS

< PRECAUTION >

PRECAUTION

PRECAUTIONS

Precaution for Supplemental Restraint System (SRS) "AIR BAG" and "SEAT BELT PRE-TENSIONER"

INFOID:000000008642855

The Supplemental Restraint System such as "AIR BAG" and "SEAT BELT PRE-TENSIONER", used along with a front seat belt, helps to reduce the risk or severity of injury to the driver and front passenger for certain types of collision. This system includes seat belt switch inputs and dual stage front air bag modules. The SRS system uses the seat belt switches to determine the front air bag deployment, and may only deploy one front air bag, depending on the severity of a collision and whether the front occupants are belted or unbelted. Information necessary to service the system safely is included in the SR and SB section of this Service Manual.

WARNING:

- To avoid rendering the SRS inoperative, which could increase the risk of personal injury or death in the event of a collision which would result in air bag inflation, all maintenance must be performed by an authorized NISSAN/INFINITI dealer.
- Improper maintenance, including incorrect removal and installation of the SRS, can lead to personal injury caused by unintentional activation of the system. For removal of Spiral Cable and Air Bag Module, see the SR section.
- Do not use electrical test equipment on any circuit related to the SRS unless instructed to in this Service Manual. SRS wiring harnesses can be identified by yellow and/or orange harnesses or harness connectors.

PRECAUTIONS WHEN USING POWER TOOLS (AIR OR ELECTRIC) AND HAMMERS

WARNING:

- When working near the Airbag Diagnosis Sensor Unit or other Airbag System sensors with the Ignition ON or engine running, DO NOT use air or electric power tools or strike near the sensor(s) with a hammer. Heavy vibration could activate the sensor(s) and deploy the air bag(s), possibly causing serious injury.
- When using air or electric power tools or hammers, always switch the Ignition OFF, disconnect the battery, and wait at least 3 minutes before performing any service.

Precautions for Drive Shaft

INFOID:000000008642856

Observe the following precautions when disassembling and assembling drive shaft.

- Joint sub-assembly does not disassemble because it is non-overhaul parts.
- Perform work in a location which is as dust-free as possible.
- Before disassembling and assembling, clean the outside of parts.
- Prevention of the entry of foreign objects must be taken into account during disassembly of the service location.
- Disassembled parts must be carefully reassembled in the correct order. If work is interrupted, a clean cover must be placed over parts.
- Paper shop cloths must be used. Fabric shop cloths must not be used because of the danger of lint adhering to parts.
- Disassembled parts (except for rubber parts) should be cleaned with kerosene which shall be removed by blowing with air or wiping with paper shop cloths.

PREPARATION

< PREPARATION >

PREPARATION

PREPARATION

Special Service Tool

INFOID:000000008642857

The actual shapes of Kent-More tools may differ from those of special service tools illustrated here.

Tool number (Kent-More No.) Tool name	Description
KV40107300 (—) Boot band crimping tool	Installing boot band
KV40107500 (—) Drive shaft attachment	Removing drive shaft
KV38107900 (—) Protector	Installing drive shaft a: 32 mm (1.26 in) dia.

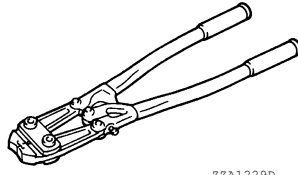

ZZA1229D



ZZA1230D

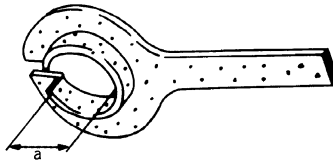

PDIA1183J

Commercial Service Tool

INFOID:000000008642858

Tool name	Description
Power tool	Loosening nuts, screws and bolts



PIIB1407E

A
B
C
FAX
E
F
G
H
I
J
K
L
M
N
O
P

NOISE, VIBRATION, AND HARSHNESS (NVH) TROUBLESHOOTING

< SYMPTOM DIAGNOSIS >

SYMPTOM DIAGNOSIS

NOISE, VIBRATION, AND HARSHNESS (NVH) TROUBLESHOOTING

NVH Troubleshooting Chart

INFOID:000000008642854

Use chart below to help you find the cause of the symptom. If necessary, repair or replace these parts.

Symptom		Possible cause and SUSPECTED PARTS											Reference page			
		Excessive joint angle	Joint sliding resistance	Imbalance	Improper installation, looseness	Parts interference	Wheel bearing damage	SUSPENSION	FRONT AXLE	TIRES	ROAD WHEEL	DRIVE SHAFT	BRAKES	STEERING		
DRIVE SHAFT	Noise	x	x						x	x	x	x		x	x	— FAX-13 , FAX-19 FAX-6 FAX-9 , FAX-10 — FAX-5 FSU-2 , " NVH Troubleshooting Chart " Refer to FRONT AXLE in this chart. WT-55 , " NVH Troubleshooting Chart " WT-55 , " NVH Troubleshooting Chart " Refer to DRIVE SHAFT in this chart. BR-6 , " NVH Troubleshooting Chart " ST-8 , " NVH Troubleshooting Chart "
	Shake	x		x				x	x	x	x		x	x		
FRONT AXLE	Noise				x	x		x		x	x	x	x	x	x	
	Shake				x	x		x		x	x	x	x	x	x	
	Vibration				x	x		x		x		x		x		
	Shimmy				x	x		x		x	x		x	x		
	Shudder				x			x		x	x		x	x		
	Poor quality ride or handling				x	x	x	x		x	x					

x: Applicable

FRONT WHEEL HUB

< PERIODIC MAINTENANCE >

PERIODIC MAINTENANCE

FRONT WHEEL HUB

Inspection

INFOID:000000008642859

- Move wheel hub and bearing assembly in the axial direction by hand. Make sure there is no looseness of wheel bearing.

Axial end play : Refer to [FAX-26, "Wheel Bearing"](#).

- Rotate wheel hub and make sure there are no unusual noises or other irregular conditions. If there are any irregular noises or conditions, replace wheel hub and bearing assembly.

A

B

C

FAX

E

F

G

H

I

J

K

L

M

N

O

P

FRONT DRIVE SHAFT

< PERIODIC MAINTENANCE >

FRONT DRIVE SHAFT

Inspection

INFOID:000000008642860

- Check drive shaft mounting point and joint for looseness and other damage.
- Check boot for cracks and other damage.

CAUTION:

Replace entire drive shaft assembly when noise or vibration occur from drive shaft.

FRONT WHEEL HUB

< REMOVAL AND INSTALLATION >

REMOVAL AND INSTALLATION

FRONT WHEEL HUB

Removal and Installation

INFOID:000000008642861

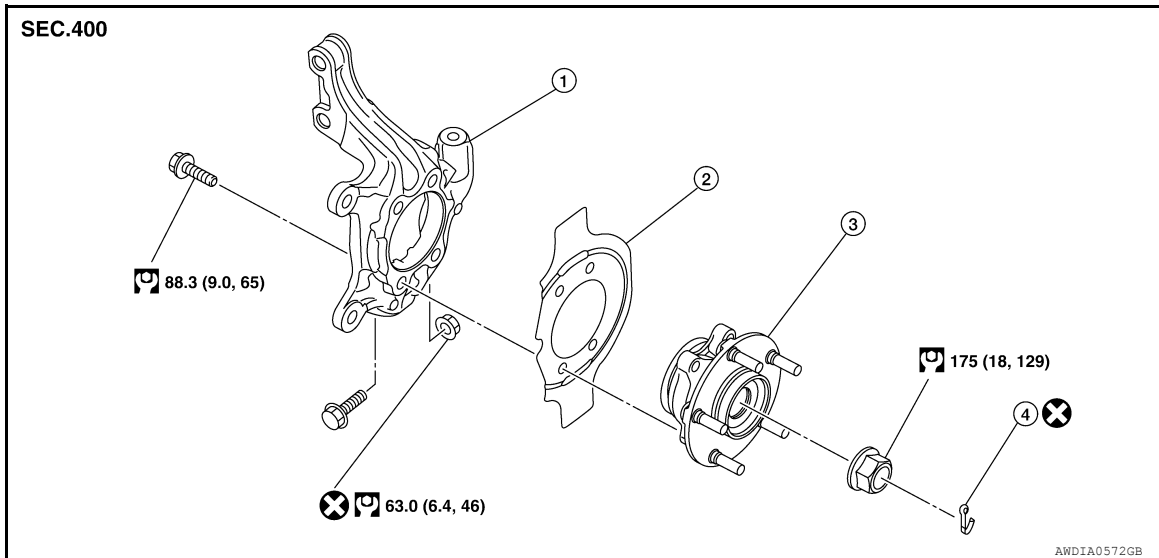

1. Steering knuckle
2. Splash guard
3. Wheel hub and bearing assembly
4. Cotter pin

REMOVAL

1. Remove wheel and tire from vehicle. Refer to [WT-60, "Adjustment"](#).
 2. Remove wheel sensor from steering knuckle. Refer to [BRC-102, "Removal and Installation - Front Wheel Sensor"](#).
- CAUTION:**
Do not pull on wheel sensor harness.
3. Remove brake hose lock plate from strut assembly.
 4. Remove brake caliper torque member bolts using power tool leaving brake hose attached, then remove disc rotor. Reposition caliper aside with wire. Refer to [BR-32, "Removal and Installation of Brake Caliper and Rotor"](#).

NOTE:

Avoid depressing brake pedal while brake caliper is removed.

5. Remove cotter pin, then loosen lock nut from drive shaft using power tool.
6. Using a piece of wood and a hammer, tap on lock nut to disengage drive shaft from wheel hub.

CAUTION:

- Never place drive shaft joint at an extreme angle. Also be careful not to overextend slide joint.
- Never allow drive shaft to hang down without support.

NOTE:

Use suitable puller if drive shaft cannot be separated from wheel hub and bearing assembly.

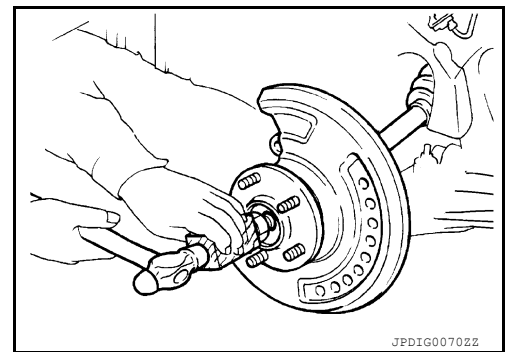

7. Remove wheel hub and bearing assembly bolts using power tool.
8. Remove splash guard and wheel hub and bearing assembly from steering knuckle.

INSPECTION AFTER REMOVAL

Check for deformity, cracks and damage on each part, replace if necessary.

FRONT WHEEL HUB

< REMOVAL AND INSTALLATION >

INSTALLATION

Installation is in the reverse order of removal.

CAUTION:

Do not reuse non-reusable parts.

- When installing wheel hub and bearing assembly to steering knuckle, align cutout in toner ring cover with wheel sensor mounting hole in steering knuckle.

FRONT DRIVE SHAFT

< REMOVAL AND INSTALLATION >

FRONT DRIVE SHAFT

Removal and Installation (Left Side)

INFOID:000000008642862

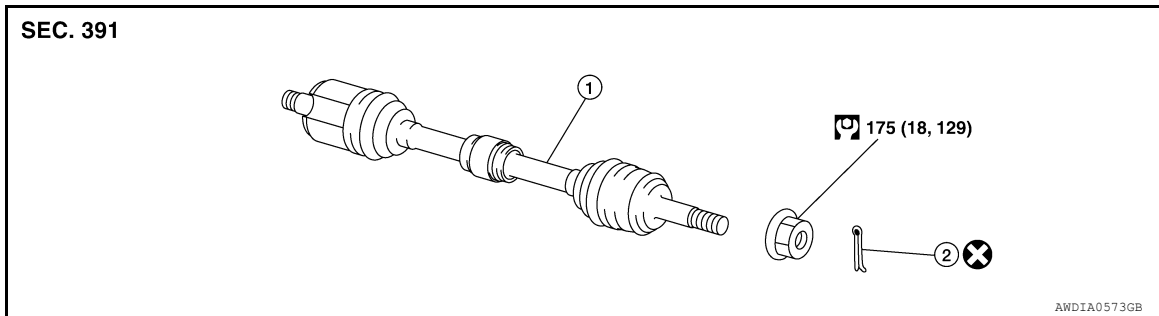

1. Drive shaft
2. Cotter pin

REMOVAL

1. Remove wheel and tire from vehicle. Refer to [WT-60, "Adjustment"](#).
2. Remove wheel sensor from steering knuckle. Refer to [BRC-102, "Removal and Installation - Front Wheel Sensor"](#).
- CAUTION:**
Do not pull on wheel sensor harness.
3. Remove brake hose lock plate from strut assembly.
4. Remove brake caliper torque member bolts using power tool leaving brake hose attached, then remove disc rotor. Reposition caliper aside with wire. Refer to [BR-32, "Removal and Installation of Brake Caliper and Rotor"](#).
- NOTE:**
Avoid depressing brake pedal while brake caliper is removed.
5. Remove cotter pin, then loosen lock nut from drive shaft using power tool.
6. Remove lower strut bolts and nuts using power tool. Refer to [FSU-13, "Exploded View"](#).
7. Using a piece of wood and a hammer, tap on lock nut to disengage drive shaft from wheel hub.

CAUTION:

- **Never place drive shaft joint at an extreme angle. Also be careful not to overextend slide joint.**
- **Never allow drive shaft to hang down without support.**

NOTE:

Use suitable puller if drive shaft cannot be separated from wheel hub and bearing assembly.

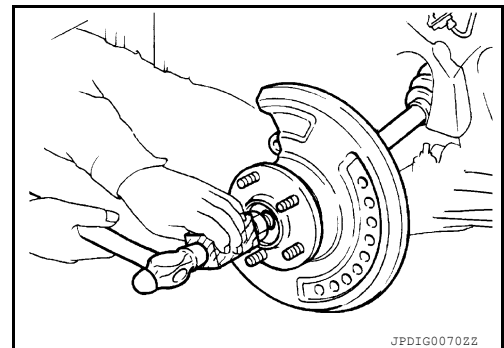

8. Remove drive shaft from transaxle assembly.
 - Use Tool (A) and sliding hammer (B) while inserting tip of tool between housing and transaxle assembly.

CAUTION:

Never place drive shaft joint at an extreme angle when removing drive shaft. Also be careful not to overextend slide joint.

Tool number (A) : KV40107500 (—)

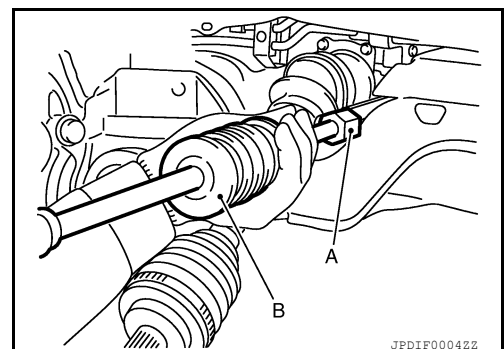

INSPECTION AFTER REMOVAL

A
B
C
FAX
E
F
G
H
I
J
K
L
M
N
O
P

FRONT DRIVE SHAFT

< REMOVAL AND INSTALLATION >

- Move joint up/down, left/right, and in axial direction. Check for any rough movement or significant looseness.
- Check boot for cracks or other damage, and for grease leakage.
- If damaged, disassemble drive shaft to verify damage, and repair or replace as necessary.

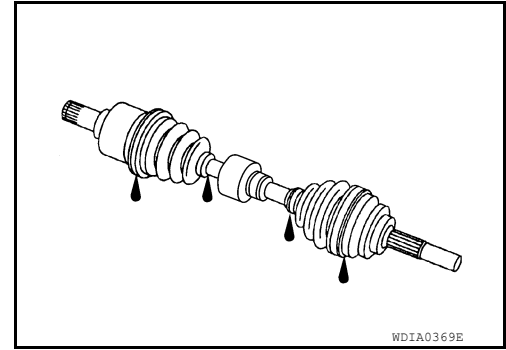

INSTALLATION

Installation is in the reverse order of removal. Note the following:

CAUTION:

Do not reuse non-reusable parts.

- Install new circlip on drive shaft in the circular clip groove on transaxle side. Refer to [FAX-13. "Disassembly and Assembly \(Left Side\)"](#).

CAUTION:

Make sure the new circlip on the drive shaft is securely fastened.

- In order to prevent damage to differential side oil seal, place Tool (A) onto oil seal before inserting drive shaft as shown. Slide drive shaft into slide joint and tap with a hammer to install securely.

Tool number (A) : KV38107900 (—)

CAUTION:

Make sure that circlip is completely engaged.

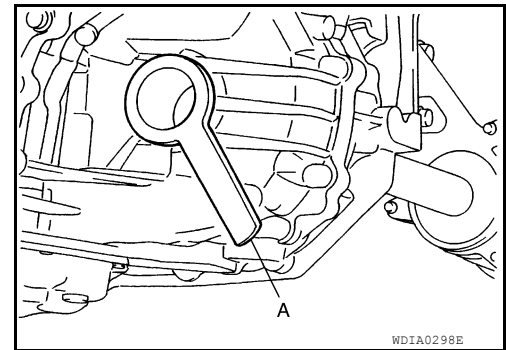

INSPECTION AFTER INSTALLATION

1. Check wheel alignment. Refer to [FSU-6. "Inspection and Adjustment"](#).
2. Adjust neutral position of steering angle sensor. Refer to [BRC-6. "ADJUSTMENT OF STEERING ANGLE SENSOR NEUTRAL POSITION : Special Repair Requirement"](#).

Removal and Installation (Right Side)

INFOID:000000008642863

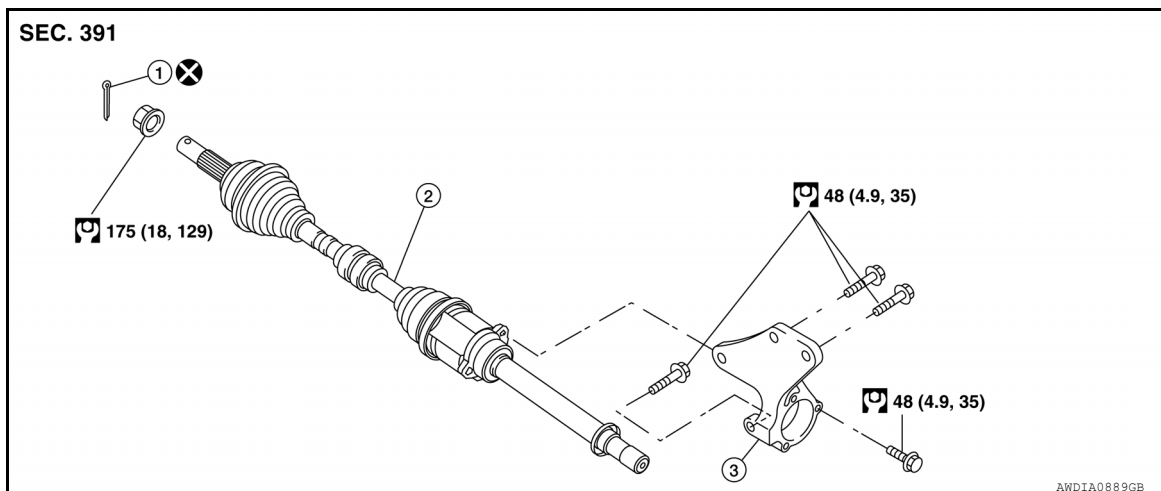

1. Cotter pin

2. Drive shaft

3. Support bearing bracket

REMOVAL

FRONT DRIVE SHAFT

< REMOVAL AND INSTALLATION >

1. Remove wheel and tire from vehicle. Refer to [WT-60, "Adjustment"](#).
2. Remove wheel sensor from steering knuckle. Refer to [BRC-102, "Removal and Installation - Front Wheel Sensor"](#).
CAUTION:
Do not pull on wheel sensor harness.
3. Remove brake hose lock plate from strut assembly.
4. Remove brake caliper torque member bolts using power tool leaving brake hose attached, then remove disc rotor. Reposition caliper aside with wire. Refer to [BR-32, "Removal and Installation of Brake Caliper and Rotor"](#).
NOTE:
Avoid depressing brake pedal while brake caliper is removed.
5. Remove cotter pin, then loosen lock nut from drive shaft using power tool.
6. Remove lower strut bolts and nuts using power tool. Refer to [FSU-13, "Exploded View"](#).

7. Using a piece of wood and a hammer, tap on lock nut to disengage drive shaft from wheel hub.

CAUTION:

- Never place drive shaft joint at an extreme angle. Also be careful not to overextend slide joint.
- Never allow drive shaft to hang down without support.

NOTE:

Use suitable puller if drive shaft cannot be separated from wheel hub and bearing assembly.

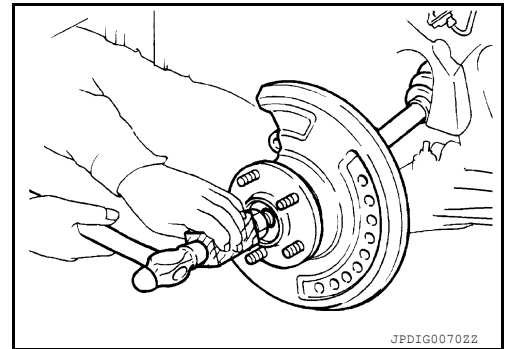

8. Remove bearing housing to support bearing bracket bolts.
9. Remove drive shaft from transaxle assembly.
 - Use Tool (A) and sliding hammer (B) while inserting tip of tool between housing and transaxle assembly.

CAUTION:

Never place drive shaft joint at an extreme angle when removing drive shaft. Also be careful not to overextend slide joint.

Tool number (A) : KV40107500 (—)

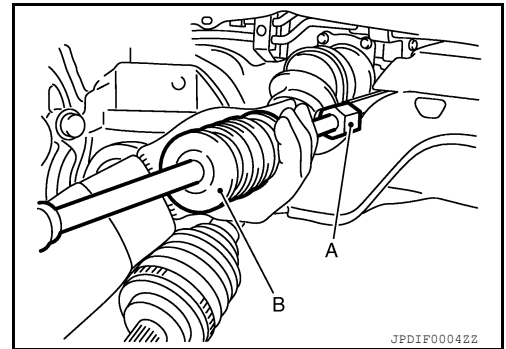

10. If necessary, remove the support bearing bracket.
 - Remove front exhaust tube. Refer to [EX-5, "Removal and Installation"](#).

INSPECTION AFTER REMOVAL

- Move joint up/down, left/right, and in axial direction. Check for any rough movement or significant looseness.
- Check boot for cracks or other damage, and for grease leakage.
- If damaged, disassemble drive shaft to verify damage, and repair or replace as necessary.

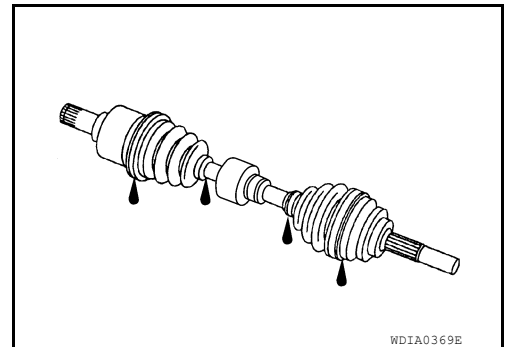

INSTALLATION

FRONT DRIVE SHAFT

< REMOVAL AND INSTALLATION >

Installation is in the reverse order of removal. Note the following:

CAUTION:

Do not reuse non-reusable parts.

- Install new circlip on drive shaft in the circular clip groove on transaxle side. Refer to [FAX-19. "Disassembly and Assembly \(Right Side\)"](#).

CAUTION:

Make sure the new circlip on the drive shaft is securely fastened.

- In order to prevent damage to differential side oil seal, place Tool (A) onto oil seal before inserting drive shaft as shown. Slide drive shaft into slide joint and tap with a hammer to install securely.

Tool number (A) : KV38107900 (—)

CAUTION:

Make sure that circlip is completely engaged.

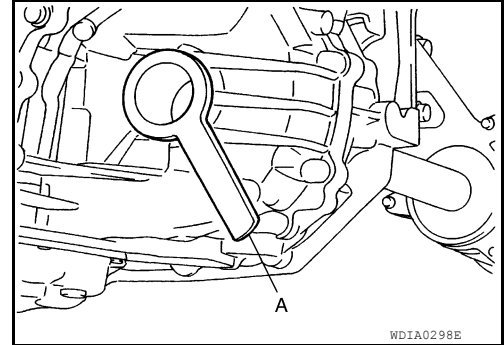

- When installing support bearing bracket, hand tighten the bolts, then tighten to specified torque.

INSPECTION AFTER INSTALLATION

1. Check wheel alignment. Refer to [FSU-6. "Inspection and Adjustment"](#).
2. Adjust neutral position of steering angle sensor. Refer to [BRC-6. "ADJUSTMENT OF STEERING ANGLE SENSOR NEUTRAL POSITION : Special Repair Requirement"](#).

FRONT DRIVE SHAFT

< UNIT DISASSEMBLY AND ASSEMBLY >

UNIT DISASSEMBLY AND ASSEMBLY

FRONT DRIVE SHAFT

Disassembly and Assembly (Left Side)

INFOID:000000008642864

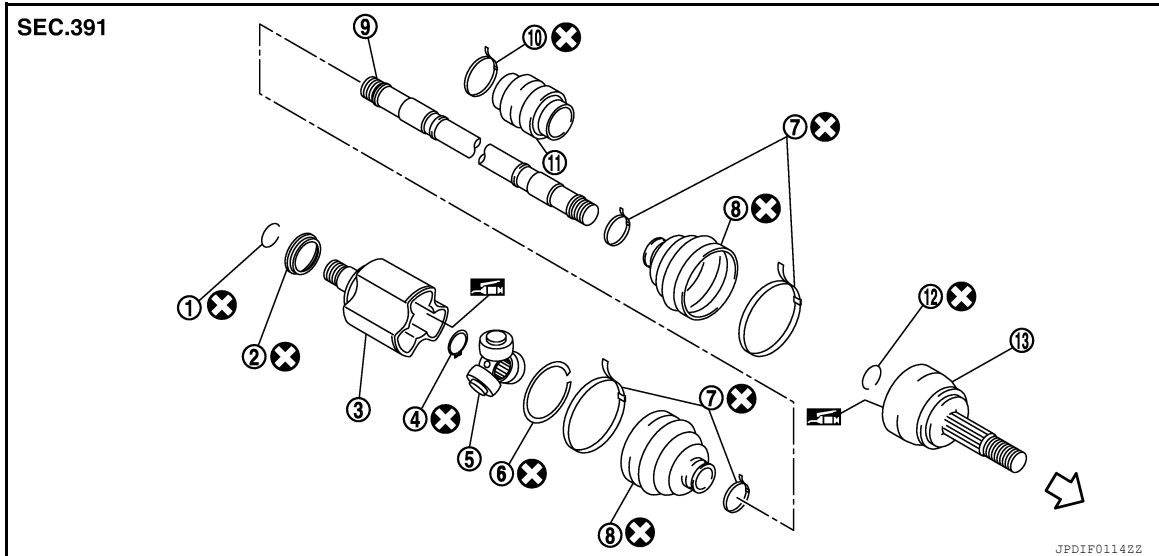

- | | | |
|------------------------|--------------------|-----------------|
| 1. Circlip | 2. Dust shield | 3. Housing |
| 4. Snap ring | 5. Spider assembly | 6. Stopper ring |
| 7. Boot band | 8. Boot | 9. Shaft |
| 10. Damper band | 11. Dynamic damper | 12. Circlip |
| 13. Joint sub-assembly | | |

← : Wheel side

 : Fill using NISSAN Genuine grease or equivalent.

DISASSEMBLY

Transaxle Side

1. Mount front drive shaft in a vise.

CAUTION:

When mounting shaft in a vise, always use copper or aluminum plates between vise and shaft.

2. Remove boot bands and slide the boot back.
3. Remove circlip and dust shield from slide joint housing.
4. Put matching marks on slide joint housing and shaft before separating slide joint assembly.
5. Remove stopper ring with a suitable tool, then pull out slide joint housing.

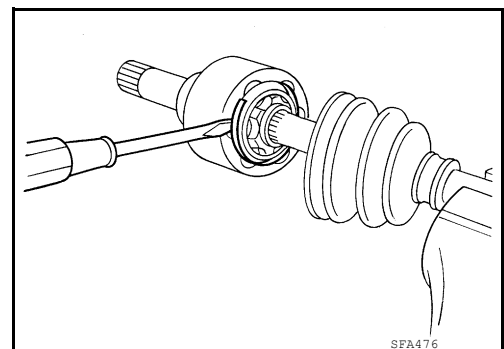

FRONT DRIVE SHAFT

< UNIT DISASSEMBLY AND ASSEMBLY >

- Put matching marks on spider assembly and shaft.

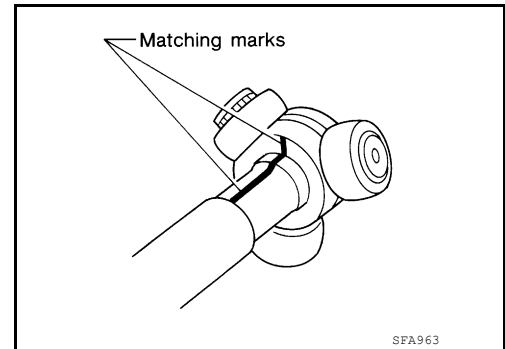

- Remove snap ring using a suitable tool, then remove spider assembly from shaft.
- Remove boot from shaft.
- Clean the old grease off of the slide joint assembly.

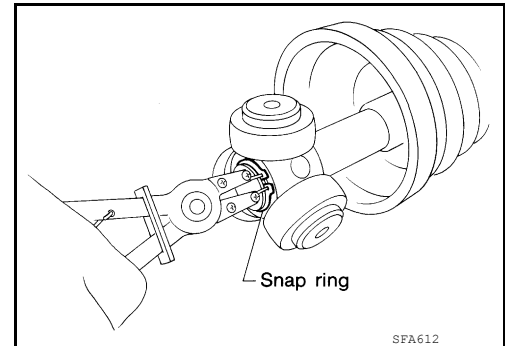

Wheel Side

- Mount the front drive shaft in a vise.

CAUTION:

When mounting shaft in a vise, always use copper or aluminum plates between vise and shaft.

- Remove boot bands and slide the boot back.
- Screw a sliding hammer or suitable tool 30 mm (1.18 in) or more into threaded part of joint sub-assembly. Pull joint sub-assembly out of shaft.

CAUTION:

- Align sliding hammer or suitable tool and drive shaft then remove joint sub-assembly by pulling directly.
- If joint sub-assembly cannot be removed after five or more unsuccessful attempts, replace the entire drive shaft assembly.

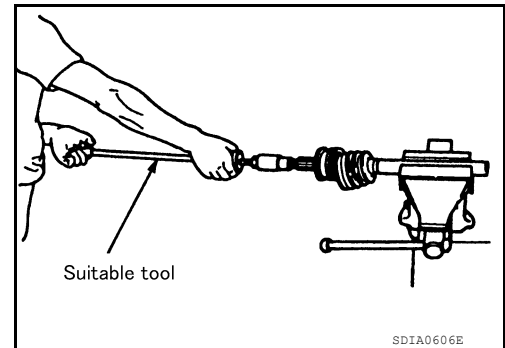

- Remove boot from shaft.
- Remove circlip from shaft.
- While rotating ball cage, clean the old grease off of the joint sub-assembly.

Damper

- Remove damper bands, then remove damper from shaft.

INSPECTION AFTER DISASSEMBLY

Shaft

- Replace shaft if there is bending, cracking, or other damage.

Joint Sub-assembly

- Make sure there is no rough rotation or unusual axial looseness.
- Make sure there is no foreign material inside joint sub-assembly.
- Check joint sub-assembly for compression scars, cracks or fractures.

CAUTION:

If there are any irregular conditions of joint sub-assembly components, replace the entire joint sub-assembly.

FRONT DRIVE SHAFT

< UNIT DISASSEMBLY AND ASSEMBLY >

Slide Joint Housing

- Make sure there are no compression scars, cracks or fractures or unusual wear of ball rolling surface.
- Make sure there is no damage to shaft screws.
- Make sure there is no deformation of boot installation parts.

Ball Cage

- Make sure there are no compression scars, cracks, fractures of sliding surface.

Steel Ball

- Make sure there are no compression scars, cracks, fractures or unusual wear.

Inner Race

- Check ball sliding surface for compression scars, cracks or fractures.
- Make sure there is no damage to serrated part.

CAUTION:

If there are any irregular conditions in the component, replace with a new set of joint sub-assembly, ball cage, steel ball and inner race.

Damper

- Check damper for cracks or wear. Install damper with new damper bands.

ASSEMBLY

Transaxle Side

1. Install new boot and new small boot band on shaft.

CAUTION:

Cover drive shaft serration with tape to prevent damage to boot during installation.

2. Remove protective tape wound around serrated part of shaft.

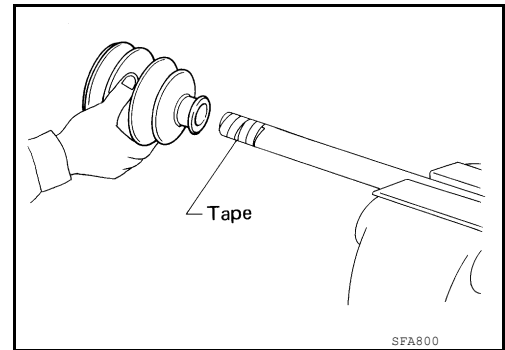

3. Install spider assembly securely, making sure the matching marks which were made during disassembly are properly aligned.
4. Install new snap ring using a suitable tool.
5. Pack drive shaft with specified amount of new grease (Genuine NISSAN Grease or equivalent).

Grease quantity : Refer to [FAX-26, "Drive Shaft"](#).

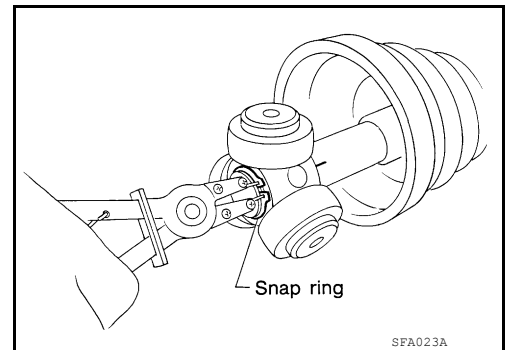

6. Install new stopper ring to housing of slide joint assembly.
7. After installation, pull shaft to check engagement between slide joint assembly and stopper ring.

FRONT DRIVE SHAFT

< UNIT DISASSEMBLY AND ASSEMBLY >

8. Install boot securely into grooves (indicated by * marks) as shown.

CAUTION:

If there is grease on boot mounting surfaces (indicated by * marks) of shaft and housing, boot may come off. Clean all grease from surfaces.

9. Make sure boot installation length (L) is the length specified below. Insert a suitable tool into the large end of boot. Bleed air from boot to prevent boot deformation.

Boot installation length (L) : Refer to FAX-26, "Drive Shaft".

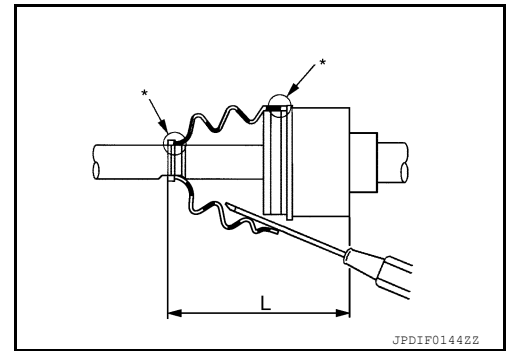

CAUTION:

- Boot may break if boot installation length is less than standard value.
- Be careful that the tool does not contact inside surface of boot.

10. Secure large end of boot with new boot band as shown.

- a. Put boot band in groove of drive shaft boot. Then insert pawls into holes.

CAUTION:

Discard old boot bands and replace with new ones.

NOTE:

Insert projection (A) and guide slit (B).

○: Pawl

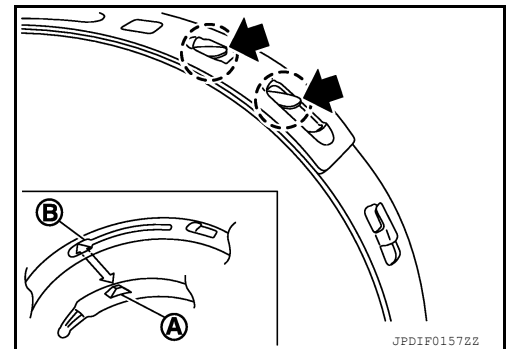

- b. Pinch projection on boot band with suitable pliers to tighten band.

- c. Insert tip of band below end of pawl.

○: Pawl

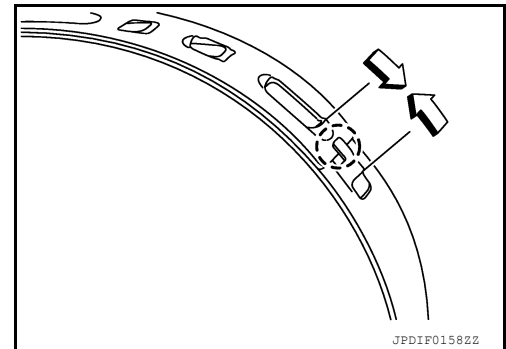

11. Install new small boot band securely using Tool.

Tool number : KV40107300 (—)

CAUTION:

Discard old boot bands and replace with new ones.

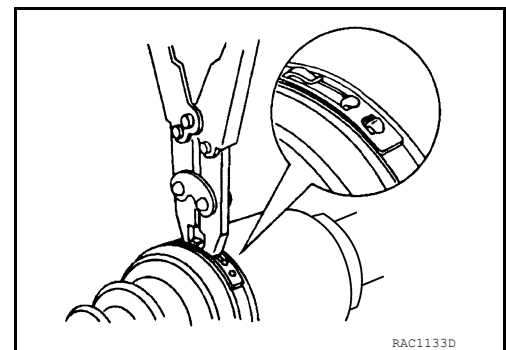

CAUTION:

FRONT DRIVE SHAFT

< UNIT DISASSEMBLY AND ASSEMBLY >

- Secure boot band so that dimension (M) meets specification as shown.

Dimension (M) : Refer to [FAX-27, "Boot Bands"](#).

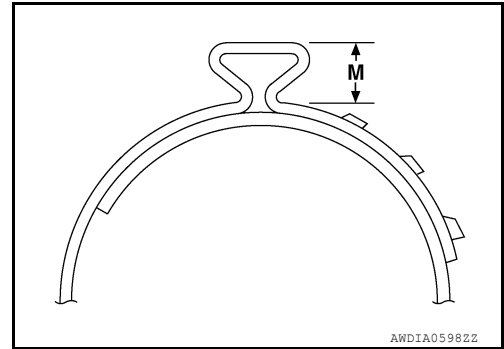

12. Install new dust shield to slide joint housing.
13. After installing housing and shaft, make sure boot position is correct. If boot position is not correct, remove old boot bands then reposition the boot and secure with new boot bands.

Wheel Side

1. Add grease (Genuine NISSAN Grease or equivalent) into joint sub-assembly serration hole until grease begins to ooze from ball groove and serration hole. After inserting grease, use a shop cloth to wipe off old grease that has oozed out.

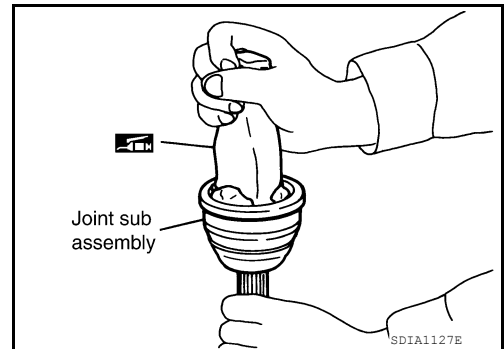

2. Cover serrated part of shaft with tape. Install new boot band and boot to shaft. Be careful not to damage boot.
CAUTION:
Discard old boot and boot band; replace with new ones.
3. Remove protective tape wound around serrated part of shaft.

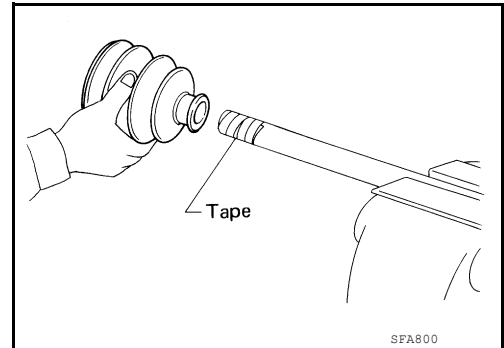

4. Attach new circlip to shaft. The circlip must fit securely into shaft groove. Attach nut to joint sub-assembly. Use a suitable tool to press-fit.
CAUTION:
Discard old circlip and replace with new one.

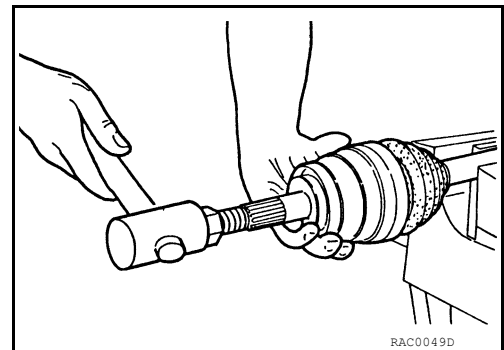

5. Insert the amount of new grease (Genuine NISSAN Grease or equivalent) listed below into housing from large end of boot.

Grease quantity : Refer to [FAX-26, "Drive Shaft"](#).

FRONT DRIVE SHAFT

< UNIT DISASSEMBLY AND ASSEMBLY >

6. Install boot securely into grooves (indicated by * marks) as shown.

CAUTION:

If there is grease on boot mounting surfaces (indicated by * marks) of shaft and housing, boot may come off. Remove all grease from surfaces.

7. Make sure boot installation length (L) is the specified length indicated below. Insert a suitable tool into the large end of boot. Bleed air from boot to prevent boot deformation.

Boot installation length (L) : Refer to [FAX-26, "Drive Shaft"](#).

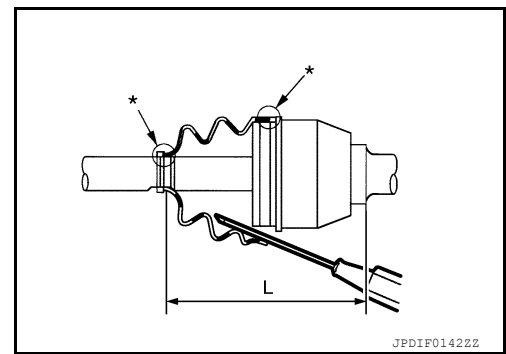

CAUTION:

- Boot may break if boot installation length is less than standard value.
- Be careful that the tool does not contact inside surface of boot.

8. Install new large and small boot bands securely using Tool.

Tool number : KV40107300 (—)

CAUTION:

Do not reuse boot bands.

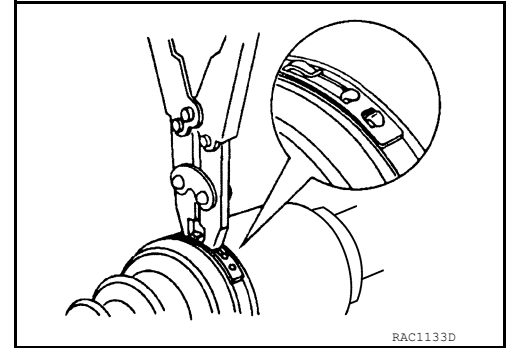

CAUTION:

- Secure boot band so that dimension (M) meets specification as shown.

Dimension (M) : Refer to [FAX-27, "Boot Bands"](#).

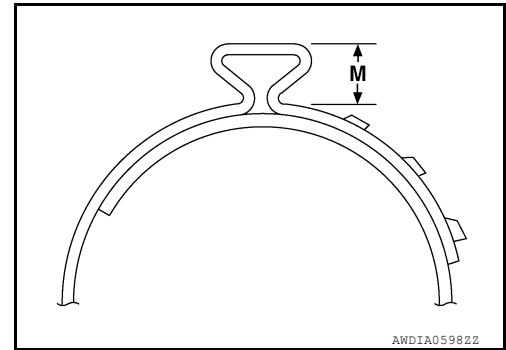

9. After installing housing and shaft, rotate boot to check whether or not the actual position is correct. If boot position is not correct, remove old boot bands then reposition the boot and secure with new boot bands.

Damper

1. Use new damper bands for installation.
2. Install damper from stationary-joint side while holding it securely.

(A) : Refer to [FAX-26, "Dynamic Damper"](#).

(B) : Refer to [FAX-26, "Dynamic Damper"](#).

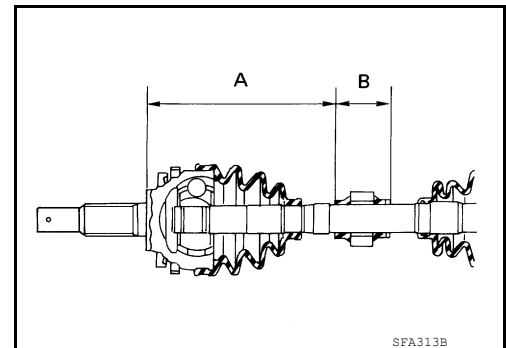

FRONT DRIVE SHAFT

< UNIT DISASSEMBLY AND ASSEMBLY >

Disassembly and Assembly (Right Side)

INFOID:000000008642865

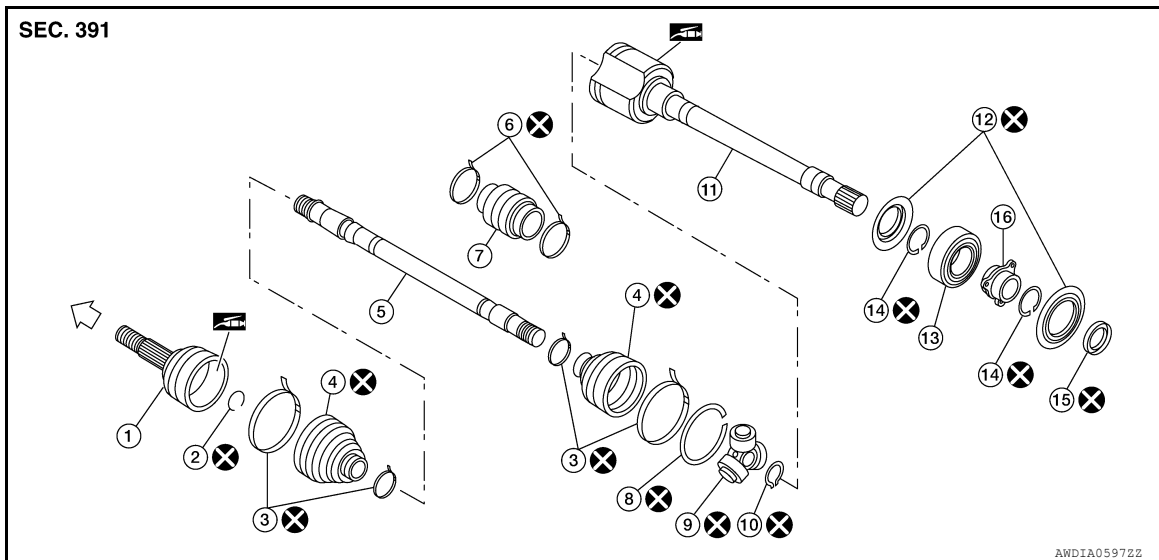

- | | | |
|-----------------------|-----------------|--------------------|
| 1. Joint sub-assembly | 2. Circlip | 3. Boot band |
| 4. Boot | 5. Shaft | 6. Damper band |
| 7. Dynamic damper | 8. Stopper ring | 9. Spider assembly |
| 10. Snap ring | 11. Housing | 12. Dust shield |
| 13. Support bearing | 14. Snap ring | 15. Dust shield |
| 16. Bearing housing | | |

← : Wheel side

: Fill using NISSAN Genuine grease or equivalent.

DISASSEMBLY

Transaxle Side

- Press shaft in a vise.
CAUTION:
When retaining shaft in a vise, always use copper or aluminum plates between vise and shaft.
- Remove circlip and dust shield from slide joint housing.
- Remove boot bands and slide the boot back.
- Put matching marks on slide joint housing and shaft before separating slide joint housing.
- Remove stopper ring using a suitable tool, then pull out slide joint housing.

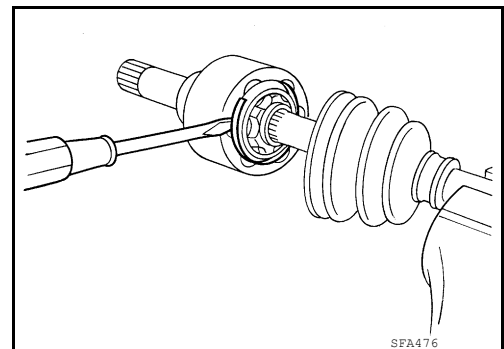

FRONT DRIVE SHAFT

< UNIT DISASSEMBLY AND ASSEMBLY >

- Put matching marks on spider assembly and shaft.

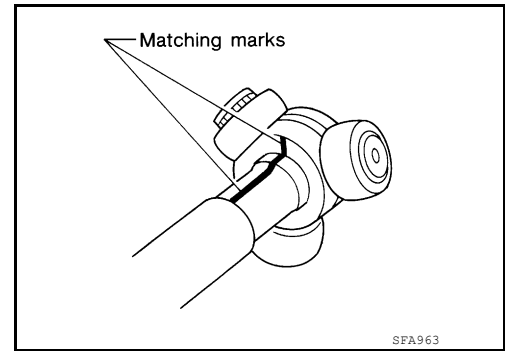

- Remove snap ring using a suitable tool, then remove spider assembly from shaft.
- Remove boot from shaft.
- Clean old grease off of the slide joint housing.

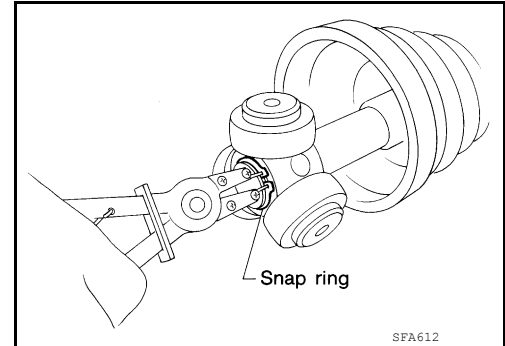

Wheel Side

- Mount the front drive shaft in a vise.

CAUTION:

When mounting shaft in a vise, always use copper or aluminum plates between vise and shaft.

- Remove boot bands and slide the boot back.
- Screw a sliding hammer or suitable tool 30 mm (1.18 in) or more into threaded part of joint sub-assembly. Pull joint sub-assembly out of shaft.

CAUTION:

- Align sliding hammer or suitable tool and drive shaft then remove joint sub-assembly by pulling directly.
- If joint sub-assembly cannot be removed after five or more unsuccessful attempts, replace the entire drive shaft assembly.

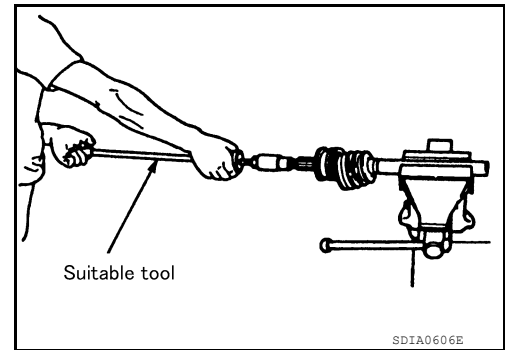

- Remove boot from shaft.
- Remove circlip from shaft.
- While rotating ball cage, clean the old grease off of the joint sub-assembly.

Support Bearing

- Remove dust shields from slide joint assembly using a suitable tool.

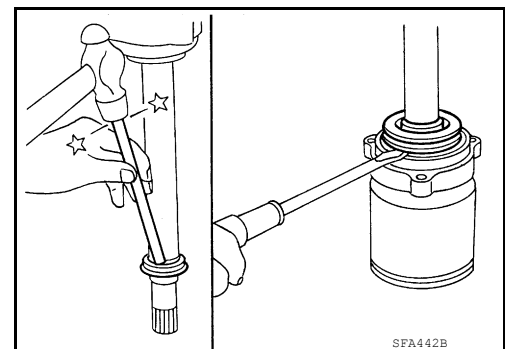

FRONT DRIVE SHAFT

< UNIT DISASSEMBLY AND ASSEMBLY >

2. Remove snap ring using a suitable tool.

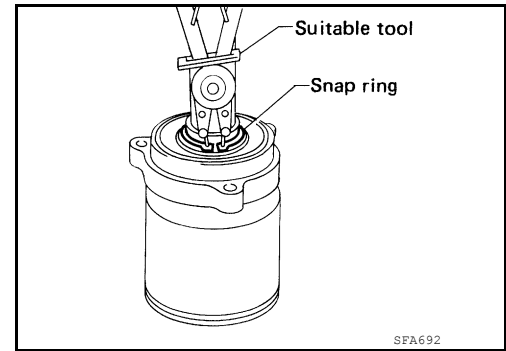

3. Press support bearing assembly off slide joint assembly using a suitable tool.

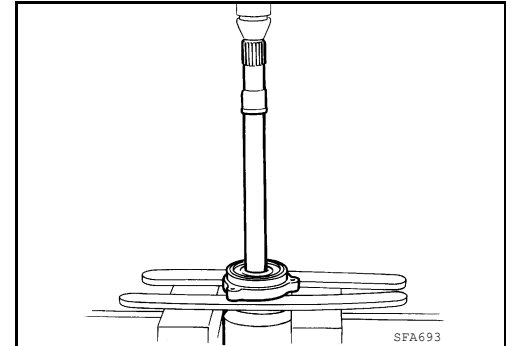

4. Separate support bearing from bracket using a suitable tool.

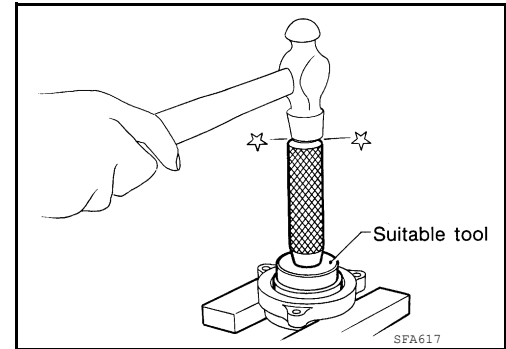

Damper

- Remove damper bands, then remove damper from shaft.

INSPECTION AFTER DISASSEMBLY

Shaft

- Replace shaft if there is any bending, cracking, or other damage.

Joint Sub-assembly

- Make sure there is no rough rotation or unusual axial looseness.
- Make sure there is no foreign material inside joint sub-assembly.
- Check joint sub-assembly for compression scars, cracks or fractures.

CAUTION:

If there are any irregular conditions of joint sub-assembly components, replace the entire joint sub-assembly.

Sliding Joint Housing and Spider Assembly

- If roller surface of spider assembly has scratches or wear, replace housing and spider assembly.

NOTE:

Housing and spider assembly are components which are used as a set.

Support Bearing

- Make sure wheel bearing rolls freely and is free from noise, cracks, pitting or wear.

Damper

- Check damper for cracks or wear. Install damper with new damper bands.

A
B
C
FAX
E
F
G
H
I
J
K
L
M
N
O
P

FRONT DRIVE SHAFT

< UNIT DISASSEMBLY AND ASSEMBLY >

ASSEMBLY

Transaxle Side

1. Cover serrated part of shaft with tape. Install new boot and boot band onto shaft. Be careful not to damage boot.

CAUTION:

Discard old boot and boot bands; replace with new ones.

2. Remove protective tape wound around serrated part of shaft.

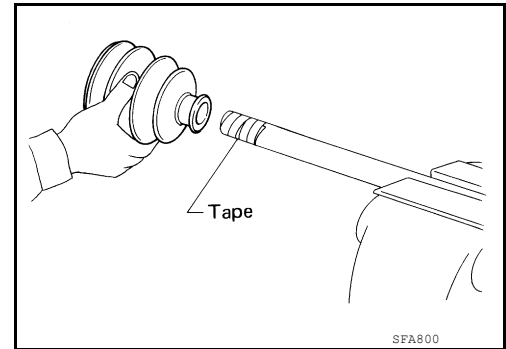

3. Install spider assembly securely, making sure the matching marks which were made during disassembly are properly aligned.
4. Install new snap ring using a suitable tool.
5. Pack drive shaft with specified amount of grease (Genuine NISSAN Grease or equivalent).

Grease quantity : Refer to [FAX-26, "Drive Shaft"](#).

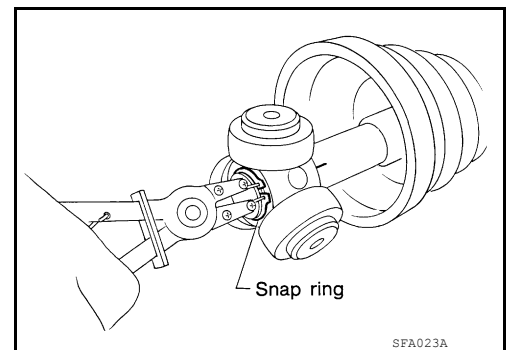

6. Install new stopper ring to slide joint assembly.
7. After installation, pull shaft to check engagement between slide joint assembly and stopper ring.
8. Install boot securely into grooves (indicated by * marks) as shown.

CAUTION:

If there is grease on boot mounting surfaces (indicated by * marks) of shaft and housing, boot may come off. Remove all grease from surfaces.

9. Make sure boot installation length (L) is the length indicated below. Insert a suitable tool into the large end of boot. Bleed air from boot to prevent boot deformation.

Boot installation length (L) : Refer to [FAX-26, "Drive Shaft"](#).

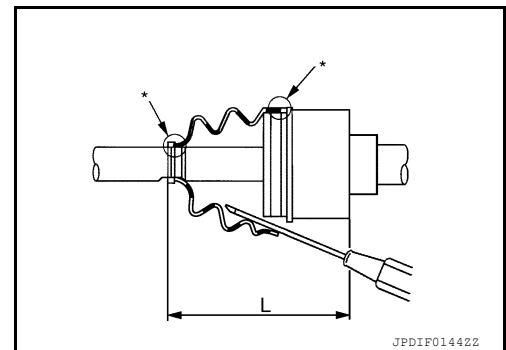

CAUTION:

- Boot may break if boot installation length is less than standard value.
- Be careful that the tool does not contact inside surface of boot.

10. Secure large end of boot with new boot band as shown.
 - a. Put boot band in groove of drive shaft boot. Then insert pawls into holes.

CAUTION:

Discard old boot bands and replace with new ones.

NOTE:

Insert projection (A) and guide slit (B).

○: Pawl

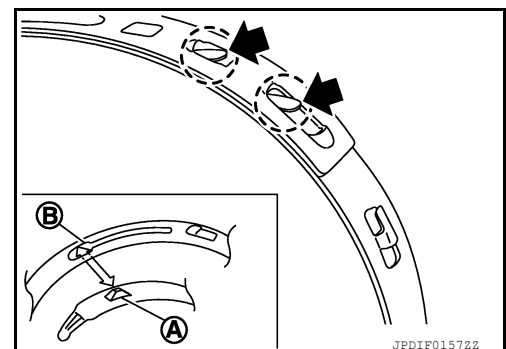

FRONT DRIVE SHAFT

< UNIT DISASSEMBLY AND ASSEMBLY >

- b. Pinch projection on boot band with suitable pliers to tighten band.
- c. Insert tip of band below end of pawl.
○: Pawl

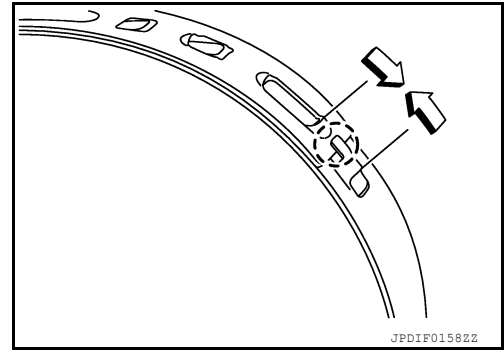

A

B

C

FAX

- 11. Install new small boot band securely using Tool.

Tool number : KV40107300 (—)

CAUTION:
Discard old boot bands and replace with new ones.

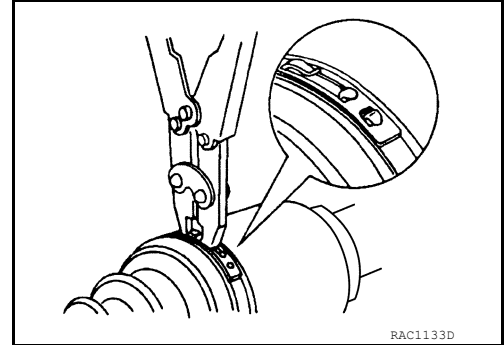

E

F

G

H

CAUTION:

- Secure boot band so that dimension (M) meets specification as shown.

Dimension (M) : Refer to [FAX-27, "Boot Bands"](#).

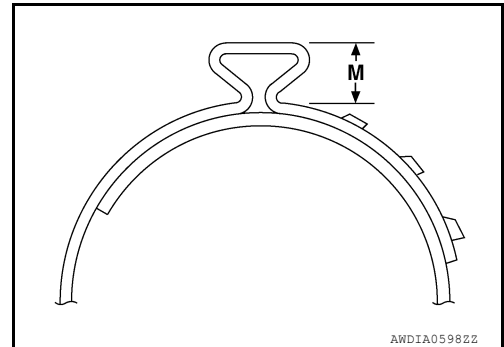

I

J

K

- 12. Install new dust shield to slide joint housing.

- 13. After installing housing and shaft, rotate boot to check whether or not the actual position is correct. If boot position is not correct, remove old boot bands then reposition the boot and secure with new boot bands.

Wheel Side

- 1. Add grease (Genuine NISSAN Grease or equivalent) into joint sub-assembly serration hole until grease begins to ooze from ball groove and serration hole. After inserting grease, use a shop cloth to wipe off old grease that has oozed out.

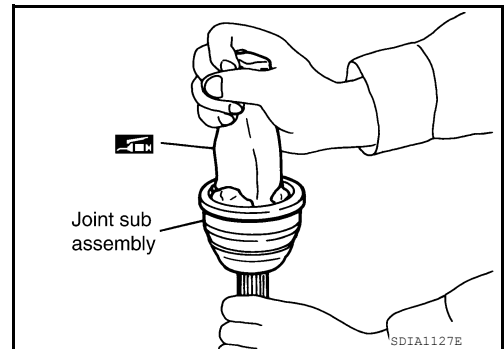

L

M

N

O

P

FRONT DRIVE SHAFT

< UNIT DISASSEMBLY AND ASSEMBLY >

2. Cover serrated part of shaft with tape. Install new boot and boot band onto shaft. Be careful not to damage boot.

CAUTION:

Discard old boot and boot bands; replace with new ones.

3. Remove protective tape wound around serrated part of shaft.

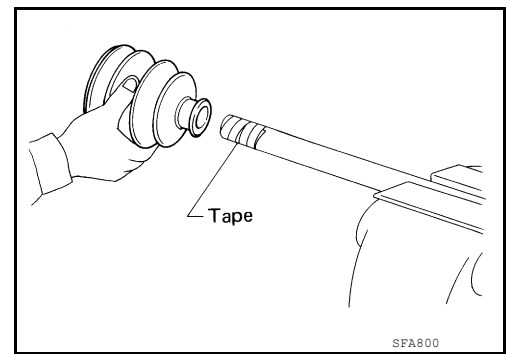

4. Attach new circlip to shaft. The circlip must fit securely into shaft groove. Attach nut to joint sub-assembly. Use a suitable tool to press-fit.

CAUTION:

Discard old circlip; replace with new ones.

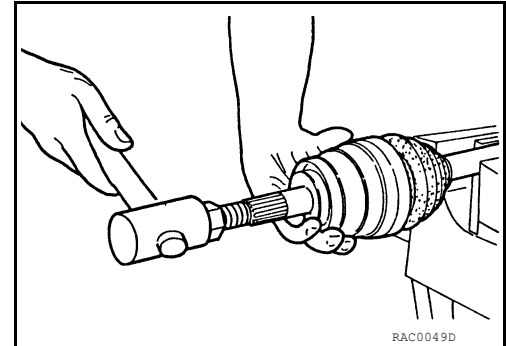

5. Insert the amount of new grease (Genuine NISSAN Grease or equivalent) listed below into housing from large end of boot.

Grease quantity : Refer to [FAX-26, "Drive Shaft"](#).

6. Install boot securely into grooves (indicated by * marks) as shown.

CAUTION:

If there is grease on boot mounting surfaces (indicated by * marks) of shaft and housing, boot may come off. Remove all grease from surfaces.

7. Make sure boot installation length (L) is the specified length, indicated below. Insert a suitable tool into the large end of boot. Bleed air from boot to prevent boot deformation.

Boot installation length (L) : Refer to [FAX-26, "Drive Shaft"](#).

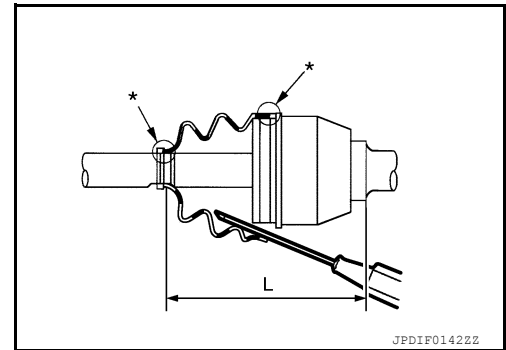

CAUTION:

- Boot may break if boot installation length is less than standard value.
- Be careful that the tool does not contact inside surface of boot.

8. Install new large and small boot bands securely using Tool.

Tool number : KV40107300 (—)

CAUTION:

Do not reuse boot bands.

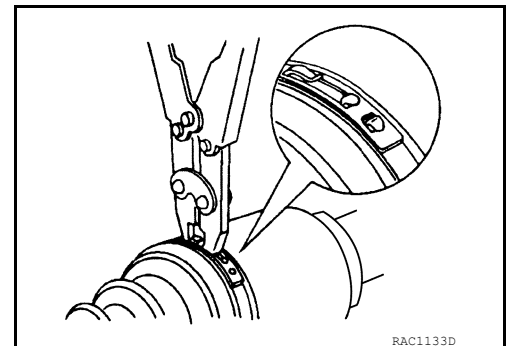

CAUTION:

FRONT DRIVE SHAFT

< UNIT DISASSEMBLY AND ASSEMBLY >

- Secure boot band so that dimension (M) meets specification as shown.

Dimension (M) : Refer to [FAX-27, "Boot Bands"](#).

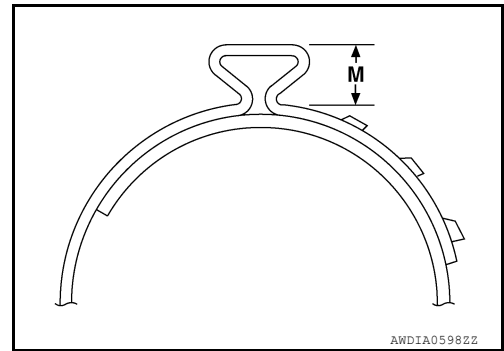

9. After installing housing and shaft, rotate boot to check whether or not the actual position is correct. If boot position is not correct, remove old boot bands then reposition the boot and secure with new boot bands.

Damper

1. Use new damper bands for installation.
2. Install damper from stationary-joint side while holding it securely.

(A) : Refer to [FAX-26, "Dynamic Damper"](#).

(B) : Refer to [FAX-26, "Dynamic Damper"](#).

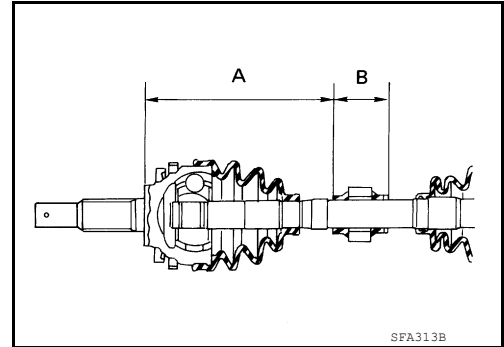

SERVICE DATA AND SPECIFICATIONS (SDS)

< SERVICE DATA AND SPECIFICATIONS (SDS)

SERVICE DATA AND SPECIFICATIONS (SDS)

SERVICE DATA AND SPECIFICATIONS (SDS)

Wheel Bearing

INFOID:000000008642866

Axial end play limit	0.05 mm (0.002 in) or less
----------------------	----------------------------

Drive Shaft

INFOID:000000008642867

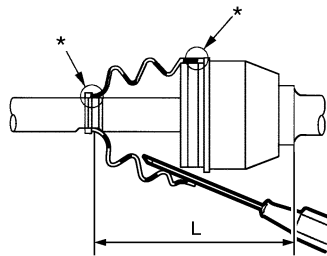

JPDIF0142ZZ

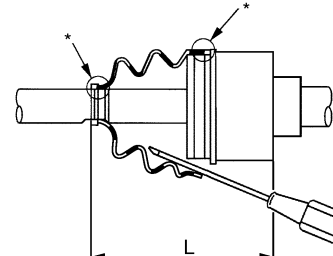

JPDIF0144ZZ

Joint type	Wheel side		Transaxle side	
	LH	RH	LH	RH
Grease quantity	170 - 190 g (6.00 - 6.70 oz)		155 - 175 g (5.47 - 6.17 oz)	
Boot installation length (L)	158.6 mm (6.42 in)		163.7 mm (6.44 in)	

*: Boot installation grooves

Dynamic Damper

INFOID:000000008642868

NOTE:

Measured from wheel side.

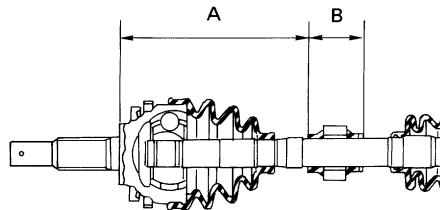

SFA313B

(A)	Left Side	207 - 213 mm (8.15 - 8.39 in)
	Right Side	202 - 208 mm (7.95 - 8.19 in)
(B)		70 mm (2.76 in)

SERVICE DATA AND SPECIFICATIONS (SDS)

< SERVICE DATA AND SPECIFICATIONS (SDS)

Boot Bands

INFOID:000000008642869

Unit: mm (in)

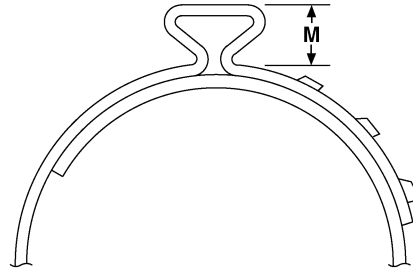

AWDIA0598ZZ

Dimension (M)	7.0 (0.28)
---------------	------------

A
B
C
E
F
G
H
I
J
K
L
M
N
O
P

FAX