

WT
SECTION
ROAD WHEELS & TIRES

A
B
C
D

WT

CONTENTS

<p>BASIC INSPECTION 3</p> <p>DIAGNOSIS AND REPAIR WORKFLOW 3</p> <p style="padding-left: 20px;">Repair Work Flow3</p> <p>INSPECTION AND ADJUSTMENT 5</p> <p style="padding-left: 20px;">Preliminary Check5</p> <p style="padding-left: 20px;">Transmitter Wake Up Operation5</p> <p style="padding-left: 20px;">ID Registration Procedure6</p> <p>SYSTEM DESCRIPTION 8</p> <p>TPMS 8</p> <p style="padding-left: 20px;">System Diagram8</p> <p style="padding-left: 20px;">System Description8</p> <p style="padding-left: 20px;">System Components10</p> <p>DIAGNOSIS SYSTEM (BCM)11</p> <p style="padding-left: 20px;">CONSULT Function (BCM - COMMON ITEM) 11</p> <p style="padding-left: 20px;">CONSULT Function (BCM - AIR PRESSURE MONITOR) 11</p> <p>DTC/CIRCUIT DIAGNOSIS13</p> <p>C1708 - C1711 DATA FROM TRANSMITTER NOT BEING RECEIVED13</p> <p style="padding-left: 20px;">Description 13</p> <p style="padding-left: 20px;">DTC Logic 13</p> <p style="padding-left: 20px;">Diagnosis Procedure 13</p> <p style="padding-left: 20px;">Special Repair Requirement 14</p> <p>C1712 - C1715, C1720 - C1723, C1724 - C1727 TRANSMITTER MALFUNCTION15</p> <p style="padding-left: 20px;">Description 15</p> <p style="padding-left: 20px;">DTC Logic 15</p> <p style="padding-left: 20px;">Diagnosis Procedure 15</p> <p style="padding-left: 20px;">Special Repair Requirement 16</p> <p>C1716 - C1719 TRANSMITTER PRESSURE MALFUNCTION17</p> <p style="padding-left: 20px;">Description 17</p> <p style="padding-left: 20px;">DTC Logic 17</p>	<p style="padding-left: 20px;">Diagnosis Procedure17</p> <p style="padding-left: 20px;">Special Repair Requirement18</p> <p>C1729 VEHICLE SPEED SIGNAL19</p> <p style="padding-left: 20px;">Description 19</p> <p style="padding-left: 20px;">DTC Logic 19</p> <p style="padding-left: 20px;">Diagnosis Procedure 19</p> <p style="padding-left: 20px;">Special Repair Requirement 19</p> <p>C1734 CONTROL UNIT20</p> <p style="padding-left: 20px;">Description20</p> <p style="padding-left: 20px;">DTC Logic20</p> <p style="padding-left: 20px;">Diagnosis Procedure20</p> <p style="padding-left: 20px;">Special Repair Requirement21</p> <p>ECU DIAGNOSIS INFORMATION22</p> <p>BCM (BODY CONTROL MODULE)22</p> <p style="padding-left: 20px;">Reference Value22</p> <p style="padding-left: 20px;">Terminal Layout27</p> <p style="padding-left: 20px;">Physical Values27</p> <p style="padding-left: 20px;">Self-Diagnosis (With CONSULT)43</p> <p style="padding-left: 20px;">Self-Diagnosis (Without CONSULT)44</p> <p>WIRING DIAGRAM46</p> <p>TIRE PRESSURE MONITORING SYSTEM46</p> <p style="padding-left: 20px;">Wiring Diagram46</p> <p>SYMPTOM DIAGNOSIS49</p> <p>TPMS49</p> <p style="padding-left: 20px;">Symptom Table49</p> <p>LOW TIRE PRESSURE WARNING LAMP DOES NOT TURN ON50</p> <p style="padding-left: 20px;">Low Tire Pressure Warning Lamp Does Not Come On When Ignition Switch Is Turned On50</p> <p>LOW TIRE PRESSURE WARNING LAMP STAYS ON51</p>
--	--

F
G
H
I
J
K
L
M
N
O
P

Low Tire Pressure Warning Lamp Stays On When Ignition Switch Is Turned On	51	PREPARATION	57
LOW TIRE PRESSURE WARNING LAMP BLINKS	52	Special Service Tool	57
Low Tire Pressure Warning Lamp Flashes When Ignition Switch Is Turned On	52	Commercial Service Tools	57
HAZARD WARNING LAMPS FLASH	53	PERIODIC MAINTENANCE	58
Hazard Warning Lamps Flash When Ignition Switch Is Turned On	53	ROAD WHEEL	58
ID REGISTRATION CANNOT BE COMPLETED	54	Inspection	58
ID Registration Cannot Be Completed	54	REMOVAL AND INSTALLATION	59
NOISE, VIBRATION AND HARSHNESS (NVH) TROUBLESHOOTING	55	TIRE PRESSURE RECEIVER	59
NVH Troubleshooting Chart	55	Removal and Installation	59
PRECAUTION	56	ROAD WHEEL TIRE ASSEMBLY	60
PRECAUTIONS	56	Adjustment	60
Precaution for Supplemental Restraint System (SRS) "AIR BAG" and "SEAT BELT PRE-TENSIONER"	56	UNIT REMOVAL AND INSTALLATION	62
Precaution for Road Wheel	56	TRANSMITTER	62
PREPARATION	57	Exploded View	62
		Removal and Installation	62
		SERVICE DATA AND SPECIFICATIONS (SDS)	65
		SERVICE DATA AND SPECIFICATIONS (SDS)	65
		Road Wheel	65
		Tire	65

DIAGNOSIS AND REPAIR WORKFLOW

< BASIC INSPECTION >

BASIC INSPECTION

DIAGNOSIS AND REPAIR WORKFLOW

Repair Work Flow

INFOID:000000008642218

WORK FLOW

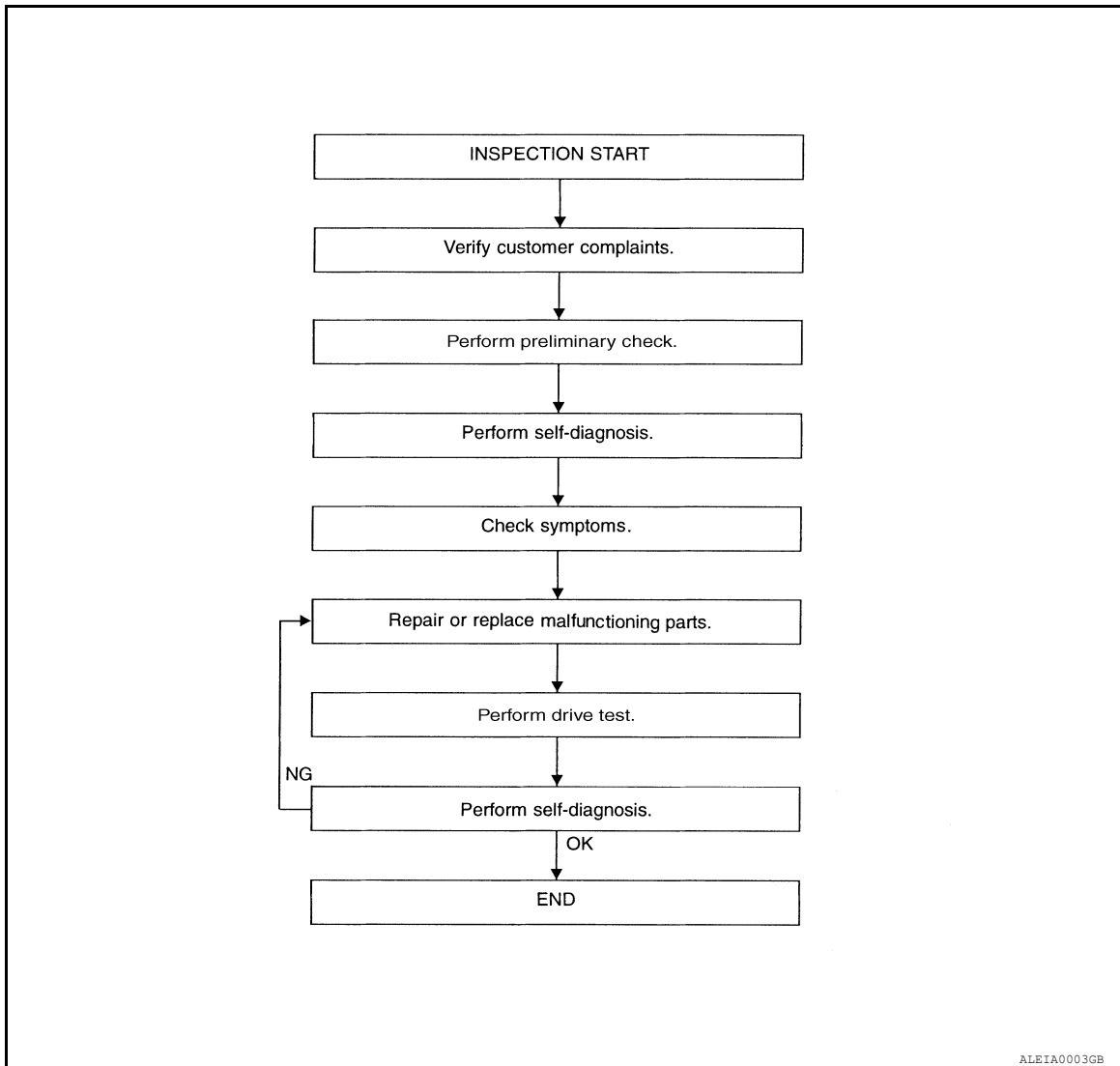

[WT-5. "Preliminary Check"](#)

[WT-43. "Self-Diagnosis \(With CONSULT\)"](#)

[WT-49. "Symptom Table"](#)

[WT-44. "Self-Diagnosis \(Without CONSULT\)"](#)

DETAILED FLOW

1. CUSTOMER INFORMATION

Interview the customer to obtain detailed information about the symptom.

>> GO TO 2

2. PRELIMINARY CHECK

Perform preliminary check. Refer to [WT-5. "Preliminary Check"](#).

>> GO TO 3

DIAGNOSIS AND REPAIR WORKFLOW

< BASIC INSPECTION >

3.SELF-DIAGNOSIS

Perform SELF-DIAGNOSIS. Refer to [WT-43. "Self-Diagnosis \(With CONSULT\)"](#) or [WT-44. "Self-Diagnosis \(Without CONSULT\)"](#).

>> GO TO 4

4.SYMPTOM

Check for symptoms. Refer to [WT-49. "Symptom Table"](#).

>> GO TO 5

5.MALFUNCTIONING PARTS

Repair or replace the applicable parts.

>> GO TO 6

6.DRIVE TEST

1. Perform a drive test.
2. Check the low tire pressure warning lamp.

>> GO TO 7

7.SELF-DIAGNOSIS

Perform SELF-DIAGNOSIS. Refer to [WT-43. "Self-Diagnosis \(With CONSULT\)"](#) or [WT-44. "Self-Diagnosis \(Without CONSULT\)"](#).

Are any DTC's displayed?

- YES >> GO TO 5
NO >> Inspection End

INSPECTION AND ADJUSTMENT

< BASIC INSPECTION >

INSPECTION AND ADJUSTMENT

Preliminary Check

INFOID:000000008642219

NOTE:

The Signal Tech II Tool (J-50190) can be used to perform the following functions. Refer to the Signal Tech II User Guide for additional information.

- Activate and display TPMS transmitter IDs
- Display tire pressure reported by the TPMS transmitter
- Read TPMS DTCs
- Register TPMS transmitter IDs

1. TIRE PRESSURE

Check all tire pressures. Refer to [WT-65, "Tire"](#).

Is the inspection result normal?

- YES >> GO TO 2
NO >> Adjust tire pressure to specified value.

2. LOW TIRE PRESSURE WARNING LAMP

Check low tire pressure warning lamp activation.

Does the low tire pressure warning lamp activate for one second when ignition switch is turned ON?

- YES >> GO TO 3
NO >> GO TO [WT-50, "Low Tire Pressure Warning Lamp Does Not Come On When Ignition Switch Is Turned On"](#).

3. BCM CONNECTOR

1. Disconnect BCM harness connectors.
2. Check terminals for damage or loose connection.
3. Reconnect harness connector.

Is the inspection result normal?

- YES >> GO TO 4
NO >> Repair or replace damaged parts.

4. TRANSMITTER ACTIVATION TOOL

Check battery in transmitter activation tool.

Is the inspection result normal?

- YES >> Perform SELF-DIAGNOSIS. Refer to [WT-43, "Self-Diagnosis \(With CONSULT\)"](#) or [WT-44, "Self-Diagnosis \(Without CONSULT\)"](#).
NO >> Replace battery in transmitter activation tool.

Transmitter Wake Up Operation

INFOID:000000008642220

NOTE:

This procedure must be done after replacement of a TPMS transmitter or BCM. New replacement transmitters are provided "asleep" and must first be "woken up" using Transmitter Activation Tool J-45295 or Signal Tech II Tool J-50190 before ID registration can be performed. Use the following procedure when using the Transmitter Activation Tool J-45295.

NOTE:

The Signal Tech II Tool (J-50190) can be used to perform the following functions. Refer to the Signal Tech II User Guide for additional information.

- Activate and display TPMS transmitter IDs
- Display tire pressure reported by the TPMS transmitter
- Read TPMS DTCs
- Register TPMS transmitter IDs

INSPECTION AND ADJUSTMENT

< BASIC INSPECTION >

1. Turn ignition switch ON. Push the transmitter activation tool against the tire near the front left transmitter. Press the button for 5 seconds. The hazard warning lamps flash per the following diagram.

Tool number : (J-45295)

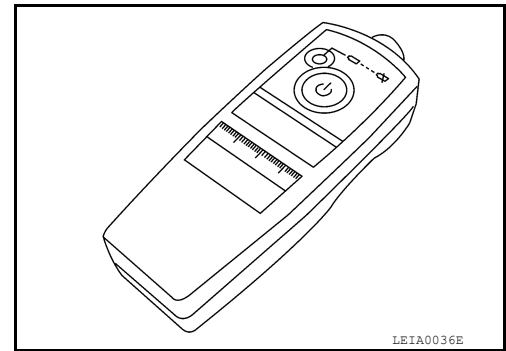

2. Repeat this procedure for each tire in the following order: FL, FR, RR, RL.
3. When the BCM finishes assigning each tire ID, the BCM flashes the hazard warning lamps and sends flashing indicator status by CAN according to the following time chart.

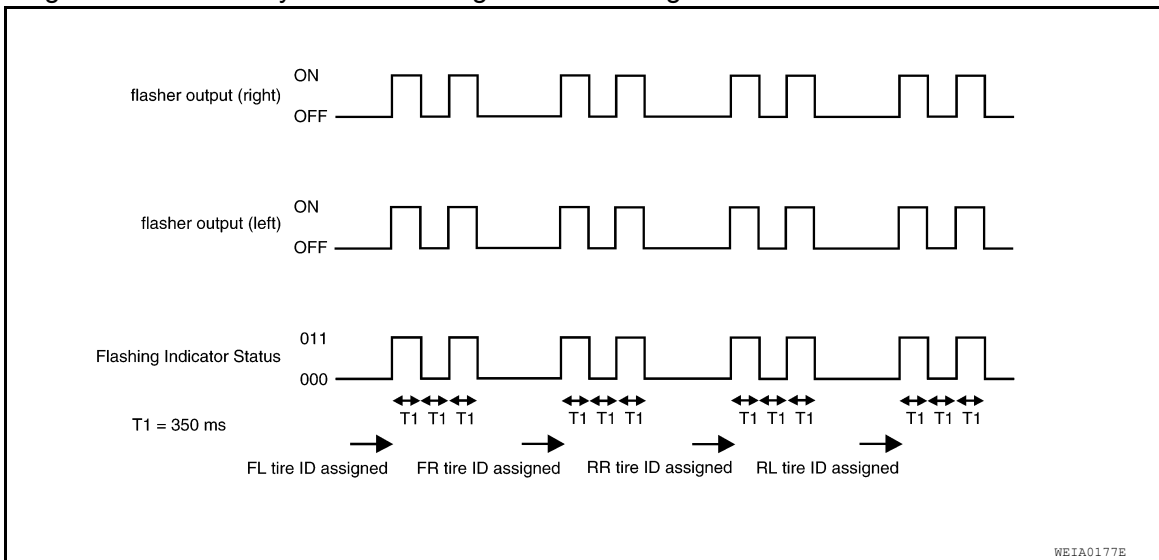

4. After completing wake up of all transmitters, make sure low tire pressure warning lamp goes out.

ID Registration Procedure

INFOID:000000008642221

NOTE:

The Signal Tech II Tool (J-50190) can be used to perform the following functions. Refer to the Signal Tech II User Guide for additional information.

- Activate and display TPMS transmitter IDs
- Display tire pressure reported by the TPMS transmitter
- Read TPMS DTCs
- Register TPMS transmitter IDs

ID REGISTRATION WITH TRANSMITTER ACTIVATION TOOL

NOTE:

This procedure must be done after replacement of a TPMS transmitter or BCM. New replacement transmitters are provided "asleep" and must first be "woken up" using Transmitter Activation Tool J-45295 or Signal Tech II Tool J-50190 before ID registration can be performed. Use the following procedure when using the Transmitter Activation Tool J-45295.

1. Connect CONSULT.
2. Select "ID REGIST" under BCM.

INSPECTION AND ADJUSTMENT

< BASIC INSPECTION >

- Push the transmitter activation tool against the tire near the front left transmitter. Press the button for 5 seconds.

Tool number : (J-45295)

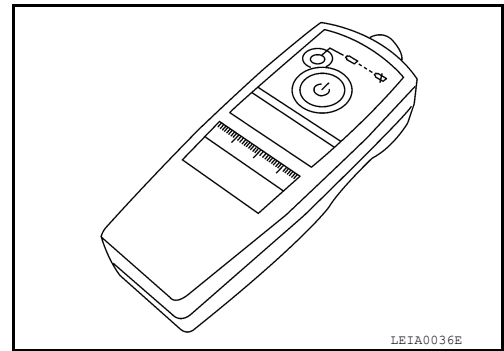

- Register the IDs in order from FR LH, FR RH, RR RH and RR LH. When ID registration of each wheel has been completed, the hazard warning lamps flash.

Step	Activation tire position	Hazard warning lamp	CONSULT
1	Front LH	2 times flashing	"YET" ↓ "DONE"
2	Front RH		
3	Rear RH		
4	Rear LH		

- After completing all ID registrations, press "END" to complete the procedure.

NOTE:

Be sure to register all of the IDs in order from FR LH, FR RH, RR RH, to RR LH, or the self-diagnostic results display will not function properly.

ID REGISTRATION WITHOUT TRANSMITTER ACTIVATION TOOL

NOTE:

This procedure must be done after replacement of a TPMS transmitter or BCM. New replacement transmitters are provided "asleep" and must first be "woken up" using Transmitter Activation Tool J-45295 or Signal Tech II Tool J-50190 before ID registration can be performed.

- Connect CONSULT.
- Select "ID REGIST" under BCM.
- Adjust the tire pressures to the values shown in the table and drive the vehicle at 40 km/h (25 MPH) or more for a few minutes.

Tire position	Tire pressure kPa (kg/cm ² , psi)
Front LH	250 (2.5, 36)
Front RH	230 (2.3, 33)
Rear RH	210 (2.1, 30)
Rear LH	190 (1.9, 27)

- After completing all ID registrations, press "END" to complete the procedure.

Activation tire position	CONSULT
Front LH	"YET" ↓ "DONE"
Front RH	
Rear RH	
Rear LH	

- Inflate all tires to proper pressure. Refer to [WT-65, "Tire"](#).

TPMS

< SYSTEM DESCRIPTION >

SYSTEM DESCRIPTION

TPMS

System Diagram

INFOID:000000008642222

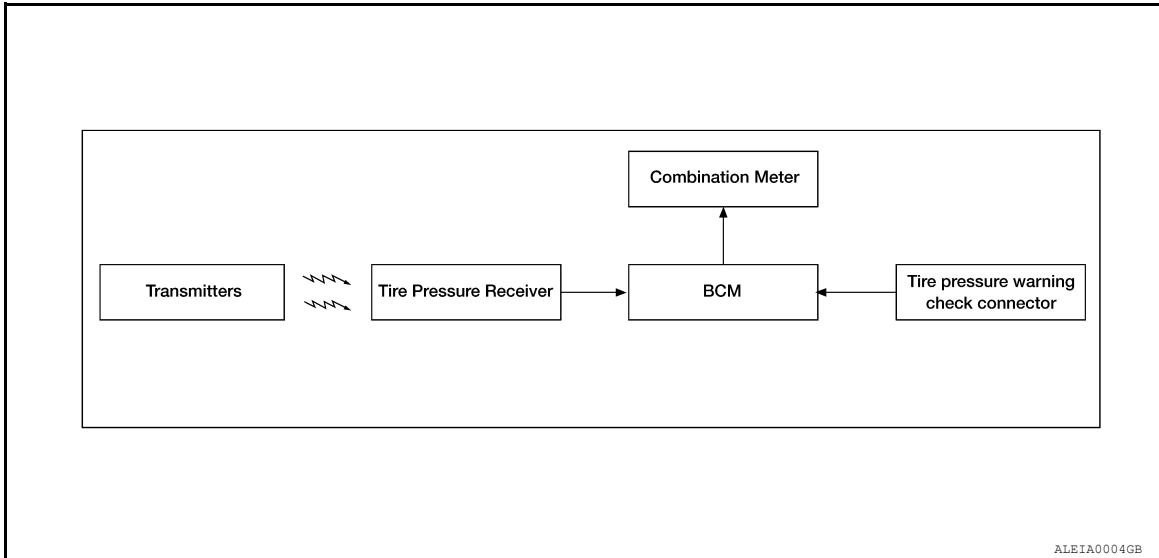

System Description

INFOID:000000008642223

DESCRIPTION

During driving, the tire pressure monitoring system receives the signal transmitted from the transmitter installed in each wheel, and turns on the low tire pressure warning lamp when the tire pressure becomes low. The control unit (BCM) for this system has pressure judgement and self-diagnosis functions.

FUNCTION

When the tire pressure monitoring system detects low inflation pressure or an internal malfunction, the low tire pressure warning lamp in the combination meter comes on. The malfunction is indicated by the low tire pressure warning lamp flashing.

BODY CONTROL MODULE (BCM)

The BCM (1) is shown with the combination meter removed. The BCM reads the air pressure signal received by the tire pressure receiver, and controls the low tire pressure warning lamp as shown below. It also has a self-diagnosis function to detect a system malfunction.

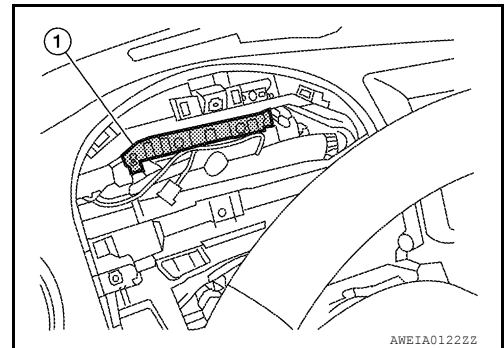

Condition	Low tire pressure warning lamp
System normal	On for 1 second after ignition ON
Tire pressure less than 174.1 kPa (1.775 kg/cm ² , 25.25 psi)	ON
Tire pressure monitoring system malfunction	After key ON, flashes once per second for 1 minute, then stays ON

TRANSMITTER

TPMS

< SYSTEM DESCRIPTION >

A sensor-transmitter integrated with a valve is installed in each wheel. It transmits a detected air pressure signal in the form of a radio wave when the vehicle is moving. The radio signal is received by the tire pressure receiver.

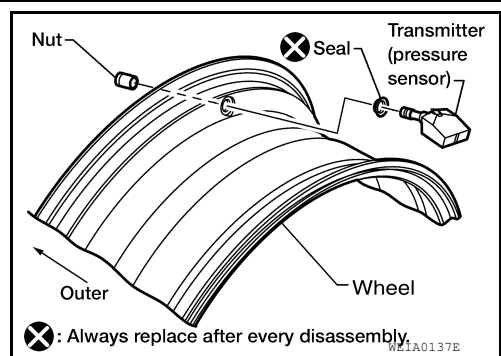

TIRE PRESSURE RECEIVER

The tire pressure receiver (1) is located on the RH side of the steering column, and is shown with the lower instrument panel LH removed. The tire pressure receiver receives the air pressure signal transmitted by the transmitter in each wheel.

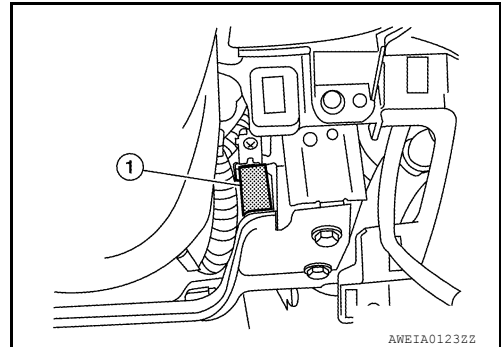

COMBINATION METER

The combination meter receives tire pressure status from the BCM using CAN communication. When a low tire pressure condition is sensed by the BCM, the combination meter low tire pressure warning lamp is activated. A CHECK TIRE PRESSURE warning message will also be displayed in the vehicle information display. Refer to the Owner's Manual for additional information.

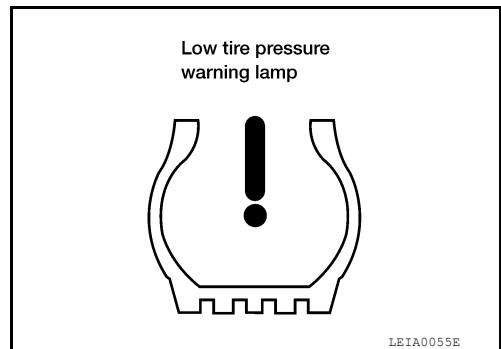

TIRE PRESSURE WARNING CHECK CONNECTOR

The tire pressure warning check connector can be grounded in order to initiate self-diagnosis without a CONSULT. Refer to [WT-44. "Self-Diagnosis \(Without CONSULT\)"](#). The tire pressure warning check connector (1) is located behind the lower portion of the instrument panel LH, above the hood release handle.

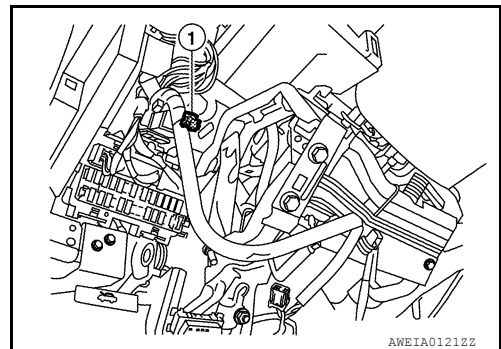

TPMS

< SYSTEM DESCRIPTION >

System Components

INFOID:000000008642224

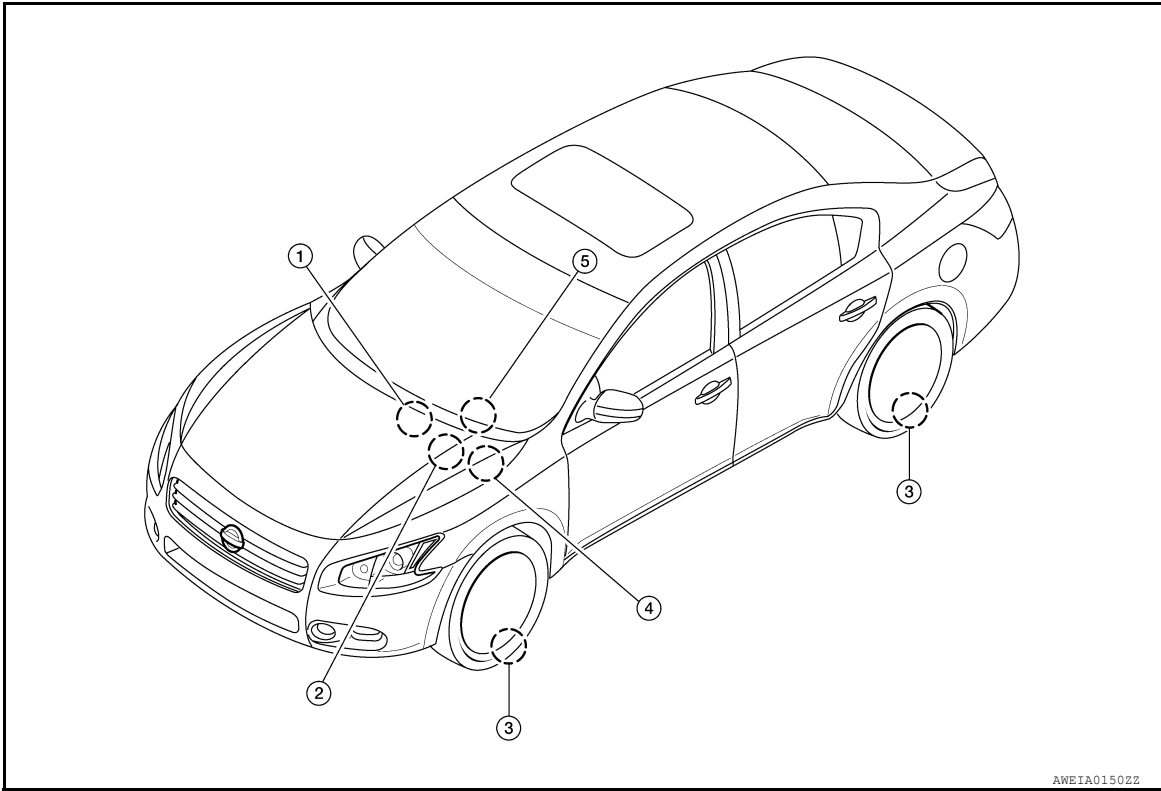

- | | | |
|--|---------------------------|-----------------|
| 1. Tire pressure receiver M70 | 2. BCM M16, M17, M18, M19 | 3. Transmitters |
| 4. Tire pressure warning check connector M62 | 5. Combination meter M24 | |

DIAGNOSIS SYSTEM (BCM)

< SYSTEM DESCRIPTION >

DIAGNOSIS SYSTEM (BCM)

CONSULT Function (BCM - COMMON ITEM)

INFOID:000000008788703

APPLICATION ITEM

CONSULT performs the following functions via CAN communication with BCM.

Direct Diagnostic Mode	Description
Ecu Identification	The BCM part number is displayed.
Self Diagnostic Result	Displays the diagnosis results judged by BCM.
Data Monitor	The BCM input/output signals are displayed.
Active Test	The signals used to activate each device are forcibly supplied from BCM.
Work support	Changes the setting for each system function.
Configuration	<ul style="list-style-type: none"> Enables to read and save the vehicle specification. Enables to write the vehicle specification when replacing BCM.
CAN Diag Support Mntr	Monitors the reception status of CAN communication viewed from BCM.

SYSTEM APPLICATION

BCM can perform the following functions.

System	Sub System	Direct Diagnostic Mode						
		Ecu Identification	Self Diagnostic Result	Data Monitor	Active Test	Work support	Configuration	CAN Diag Support Mntr
Door lock	DOOR LOCK		×	×	×	×		
Rear window defogger	REAR DEFOGGER			×	×			
Warning chime	BUZZER			×	×			
Interior room lamp timer	INT LAMP			×	×	×		
Exterior lamp	HEADLAMP			×	×	×		
Wiper and washer	WIPER			×	×	×		
Turn signal and hazard warning lamps	FLASHER			×	×	×		
Intelligent Key system	INTELLIGENT KEY			×	×	×		
Combination switch	COMB SW			×				
BCM	BCM	×	×			×	×	×
Immobilizer	IMMU		×	×	×			
Interior room lamp battery saver	BATTERY SAVER			×	×	×		
Trunk open	TRUNK			×	×			
Vehicle security system	THEFT ALM			×	×	×		
RAP system	RETAINED PWR			×				
Signal buffer system	SIGNAL BUFFER			×	×			
TPMS	AIR PRESSURE MONITOR		×	×	×	×		

CONSULT Function (BCM - AIR PRESSURE MONITOR)

INFOID:000000008788704

SELF DIAGNOSTIC RESULT

NOTE:

DIAGNOSIS SYSTEM (BCM)

< SYSTEM DESCRIPTION >

Before performing Self Diagnostic Result, be sure to register the ID, or else the actual malfunction may be different from that displayed on CONSULT.

Refer to [BCS-64. "DTC Index"](#).

DATA MONITOR

Monitor Item	Condition	Specification
AIR PRESS FL	<ul style="list-style-type: none"> • Drive vehicle for a few minutes. <li style="text-align: center;">or • Ignition switch ON and activation tool is transmitting activation signals. 	Tire pressure (kPa, kg/cm ² or Psi)
AIR PRESS FR		
AIR PRESS RR		
AIR PRESS RL		
ID REGST FL1	Ignition switch ON	Registration ID: Green No registration: Red
ID REGST FR1		
ID REGST RR1		
ID REGST RL1		
WARNING LAMP	Ignition switch ON	Low tire pressure warning lamp on: ON Low tire pressure warning lamp off: OFF
BUZZER	Ignition switch ON	Buzzer in combination meter on: ON Buzzer in combination meter off: OFF

ACTIVE TEST

Test Item	Description
WARNING LAMP	This test is able to check tire pressure warning lamp operation [On/Off].
ID REGIST WARNING	This test is able to check ID regist warning chime operation [On/Off].
FLASHER	This test is able to check turn signal lamp operation [Off/LH/RH].
HORN	This test is able to check horn operation [On].

WORK SUPPORT

Support Item	Description
ID READ	The registered ID number is displayed.
ID REGIST	Refer to WT-6. "ID Registration Procedure" .

C1708 - C1711 DATA FROM TRANSMITTER NOT BEING RECEIVED

< DTC/CIRCUIT DIAGNOSIS >

DTC/CIRCUIT DIAGNOSIS

C1708 - C1711 DATA FROM TRANSMITTER NOT BEING RECEIVED

Description

INFOID:000000008642227

Tire pressure data for one or more transmitters is not being received by the BCM.

DTC Logic

INFOID:000000008642228

NOTE:

The Signal Tech II Tool (J-50190) can be used to perform the following functions. Refer to the Signal Tech II User Guide for additional information.

- Activate and display TPMS transmitter IDs
- Display tire pressure reported by the TPMS transmitter
- Read TPMS DTCs
- Register TPMS transmitter IDs

DTC DETECTION LOGIC

DTC	CONSULT	DTC detecting condition
C1708	[NO - DATA] - FL	Data from FL transmitter cannot be received.
C1709	[NO - DATA] - FR	Data from FR transmitter cannot be received.
C1710	[NO - DATA] - RR	Data from RR transmitter cannot be received.
C1711	[NO - DATA] - RL	Data from RL transmitter cannot be received.

DTC CONFIRMATION PROCEDURE

1.ID REGISTRATION AND VEHICLE DRIVING

1. Carry out ID registration of all transmitters. Refer to [WT-6, "ID Registration Procedure"](#).
2. Drive at a speed of 40 km/h (25 MPH) or more for 3 minutes, and then drive the vehicle at any speed for 10 minutes.
3. Check all tire pressures with CONSULT within 5 minutes.

Does "DATA MONITOR ITEM" display tire pressure as normal without any warning lamp?

YES >> Inspection End.

NO >> Refer to [WT-13, "Diagnosis Procedure"](#).

Diagnosis Procedure

INFOID:000000008642229

NOTE:

The Signal Tech II Tool (J-50190) can be used to perform the following functions. Refer to the Signal Tech II User Guide for additional information.

- Activate and display TPMS transmitter IDs
- Display tire pressure reported by the TPMS transmitter
- Read TPMS DTCs
- Register TPMS transmitter IDs

MALFUNCTION CODE NO. 21, 22, 23 OR 24 (DTC C1708, C1709, C1710 OR C1711)

1.CHECK BCM

Drive for several minutes. Check all tire pressures with CONSULT.

Are all tire pressures displayed as 0 kPa?

YES >> GO TO 2

NO >> GO TO 3

2.CHECK TIRE PRESSURE RECEIVER CONNECTOR

Check tire pressure receiver connector for damage or loose connections.

Is the inspection result normal?

C1708 - C1711 DATA FROM TRANSMITTER NOT BEING RECEIVED

< DTC/CIRCUIT DIAGNOSIS >

- YES >> Replace BCM, then GO TO 3. Refer to [BCS-79, "Removal and Installation"](#).
NO >> Repair or replace tire pressure receiver connector.

3.PERFORM ID REGISTRATION

Carry out ID registration of all transmitters. Refer to [WT-6, "ID Registration Procedure"](#).

Is there a tire that cannot register ID?

- YES >> Replace malfunctioning transmitter, then GO TO 5. Refer to [WT-62, "Removal and Installation"](#).
NO >> GO TO 4

4.DRIVE VEHICLE

1. Drive at a speed of 40 km/h (25 MPH) or more for several minutes without stopping.
2. Check all tire pressures with CONSULT within 15 minutes after vehicle speed becomes 17 km/h (11 MPH).

Does "DATA MONITOR ITEM" display tire pressure as normal without any warning lamp?

- YES >> Inspection End.
NO >> GO TO 5

5.ID REGISTRATION AND VEHICLE DRIVING

1. Carry out ID registration of all transmitters. Refer to [WT-6, "ID Registration Procedure"](#).
2. Drive at a speed of 40 km/h (25 MPH) or more for 3 minutes, and then drive the vehicle at any speed for 10 minutes.
3. Check all tire pressures with CONSULT within 5 minutes.

Does "DATA MONITOR ITEM" display tire pressure as normal without any warning lamp?

- YES >> Inspection End.
NO >> Proceed to the inspection applicable to DTC.

Special Repair Requirement

INFOID:000000008642230

Perform preliminary check. Refer to [WT-5, "Preliminary Check"](#).

C1712 - C1715, C1720 - C1723, C1724 - C1727 TRANSMITTER MALFUNCTION

< DTC/CIRCUIT DIAGNOSIS >

C1712 - C1715, C1720 - C1723, C1724 - C1727 TRANSMITTER MALFUNCTION

Description

INFOID:000000008642231

One or more transmitters are malfunctioning internally.

DTC Logic

INFOID:000000008642232

NOTE:

The Signal Tech II Tool (J-50190) can be used to perform the following functions. Refer to the Signal Tech II User Guide for additional information.

- Activate and display TPMS transmitter IDs
- Display tire pressure reported by the TPMS transmitter
- Read TPMS DTCs
- Register TPMS transmitter IDs

DTC DETECTION LOGIC

DTC	CONSULT	DTC detecting condition
C1712	[CHECKSUM - ERR] - FL	Checksum data from FL transmitter is malfunctioning.
C1713	[CHECKSUM - ERR] - FR	Checksum data from FR transmitter is malfunctioning.
C1714	[CHECKSUM - ERR] - RR	Checksum data from RR transmitter is malfunctioning.
C1715	[CHECKSUM - ERR] - RL	Checksum data from RL transmitter is malfunctioning.
C1720	[CODE - ERR] - FL	Function code data from FL transmitter is malfunctioning.
C1721	[CODE - ERR] - FR	Function code data from FR transmitter is malfunctioning.
C1722	[CODE - ERR] - RR	Function code data from RR transmitter is malfunctioning.
C1723	[CODE - ERR] - RL	Function code data from RL transmitter is malfunctioning.
C1724	[BATT - VOLT - LOW] - FL	Battery voltage of FL transmitter drops.
C1725	[BATT - VOLT - LOW] - FR	Battery voltage of FR transmitter drops.
C1726	[BATT - VOLT - LOW] - RR	Battery voltage of RR transmitter drops.
C1727	[BATT - VOLT - LOW] - RL	Battery voltage of RL transmitter drops.

DTC CONFIRMATION PROCEDURE

1. DRIVE VEHICLE

1. Drive at a speed of 40 km/h (25 MPH) or more for 3 minutes, and then drive the vehicle at any speed for 10 minutes.
2. Check all tire pressures with CONSULT within 5 minutes.

Does "DATA MONITOR ITEM" display tire pressure as normal without any warning lamp?

YES >> Inspection End.

NO >> Refer to [WT-15, "Diagnosis Procedure"](#).

Diagnosis Procedure

INFOID:000000008642233

NOTE:

The Signal Tech II Tool (J-50190) can be used to perform the following functions. Refer to the Signal Tech II User Guide for additional information.

- Activate and display TPMS transmitter IDs
- Display tire pressure reported by the TPMS transmitter
- Read TPMS DTCs
- Register TPMS transmitter IDs

MALFUNCTION CODE NO. 31, 32, 33, 34, 41, 42, 43, 44, 45, 46, 47 OR 48 (DTC C1712, C1713, C1714, C1715, C1720, C1721, C1722, C1723, C1724, C1725, C1726 OR C1727)

C1712 - C1715, C1720 - C1723, C1724 - C1727 TRANSMITTER MALFUNCTION

< DTC/CIRCUIT DIAGNOSIS >

1. PERFORM ID REGISTRATION

1. Carry out ID registration of all transmitters. Refer to [WT-6, "ID Registration Procedure"](#).
2. Drive at a speed of 40 km/h (25 MPH) or more for 3 minutes, and then drive the vehicle at any speed for 10 minutes.

>> GO TO 2

2. REPLACE TRANSMITTER

1. Check low tire pressure warning lamp again for flashing, replace malfunctioning transmitter. Refer to [WT-62, "Removal and Installation"](#).
2. Carry out ID registration of all transmitters. Refer to [WT-6, "ID Registration Procedure"](#).

Can ID registration of all transmitters be completed?

YES >> GO TO 3

NO >> GO TO [WT-13, "Diagnosis Procedure"](#).

3. DRIVE VEHICLE

1. Drive at a speed of 40 km/h (25 MPH) or more for 3 minutes, and then drive the vehicle at any speed for 10 minutes.
2. Check all tire pressures with CONSULT within 5 minutes.

Does "DATA MONITOR ITEM" display tire pressure as normal without any warning lamp?

YES >> Inspection End.

NO >> Replace malfunctioning transmitter, and perform Step 3 again. Refer to [WT-62, "Removal and Installation"](#).

Special Repair Requirement

INFOID:000000008642234

Perform preliminary check. Refer to [WT-5, "Preliminary Check"](#).

C1716 - C1719 TRANSMITTER PRESSURE MALFUNCTION

< DTC/CIRCUIT DIAGNOSIS >

C1716 - C1719 TRANSMITTER PRESSURE MALFUNCTION

Description

INFOID:000000008642235

Air pressure data from one or more transmitters is out of range.

DTC Logic

INFOID:000000008642236

NOTE:

The Signal Tech II Tool (J-50190) can be used to perform the following functions. Refer to the Signal Tech II User Guide for additional information.

- Activate and display TPMS transmitter IDs
- Display tire pressure reported by the TPMS transmitter
- Read TPMS DTCs
- Register TPMS transmitter IDs

DTC DETECTION LOGIC

DTC	CONSULT	DTC detecting condition
C1716	[PRESSDATA - ERR] FL	Air pressure data from FL transmitter is malfunctioning.
C1717	[PRESSDATA - ERR] FR	Air pressure data from FR transmitter is malfunctioning.
C1718	[PRESSDATA - ERR] RR	Air pressure data from RR transmitter is malfunctioning.
C1719	[PRESSDATA - ERR] RL	Air pressure data from RL transmitter is malfunctioning.

DTC CONFIRMATION PROCEDURE

1.ID REGISTRATION AND VEHICLE DRIVING

1. Carry out ID registration of all transmitters. Refer to [WT-6. "ID Registration Procedure"](#).
2. Drive at a speed of 40 km/h (25 MPH) or more for 3 minutes, and then drive the vehicle at any speed for 10 minutes.
3. Check all tire pressures with CONSULT within 5 minutes.

Does "DATA MONITOR ITEM" display tire pressure as normal without any warning lamp?

YES >> Inspection End.

NO >> Refer to [WT-17. "Diagnosis Procedure"](#).

Diagnosis Procedure

INFOID:000000008642237

NOTE:

The Signal Tech II Tool (J-50190) can be used to perform the following functions. Refer to the Signal Tech II User Guide for additional information.

- Activate and display TPMS transmitter IDs
- Display tire pressure reported by the TPMS transmitter
- Read TPMS DTCs
- Register TPMS transmitter IDs

MALFUNCTION CODE NO. 35, 36, 37 OR 38 (DTC C1716, C1717, C1718 OR C1719)

1.CHECK ALL TIRE PRESSURES

Check all tire pressures. Refer to [WT-65. "Tire"](#).

Are there any tires with pressure of 64 psi or more?

YES >> Adjust tire pressure to specified value.

NO >> GO TO 2

2.ID REGISTRATION AND VEHICLE DRIVING

1. Carry out ID registration of all transmitters. Refer to [WT-6. "ID Registration Procedure"](#).
2. Drive at a speed of 40 km/h (25 MPH) or more for several minutes without stopping.
3. Check all tire pressures with CONSULT within 15 minutes after vehicle speed becomes 17 km/h (11 MPH).

C1716 - C1719 TRANSMITTER PRESSURE MALFUNCTION

< DTC/CIRCUIT DIAGNOSIS >

Does "DATA MONITOR ITEM" display 64 psi or more?

- YES >> Replace malfunctioning transmitter, then GO TO 3. Refer to [WT-62, "Removal and Installation"](#).
NO >> GO TO 3

3.ID REGISTRATION AND VEHICLE DRIVING

1. Carry out ID registration of all transmitters. Refer to [WT-6, "ID Registration Procedure"](#).
2. Drive at a speed of 40 km/h (25 MPH) or more for 3 minutes, and then drive the vehicle at any speed for 10 minutes.
3. Check all tire pressures with CONSULT within 5 minutes.

Does "DATA MONITOR ITEM" display tire pressure as normal without any warning lamp?

- YES >> Inspection End.
NO >> Proceed to the inspection applicable to DTC.

Special Repair Requirement

INFOID:000000008642238

Perform preliminary check. Refer to [WT-5, "Preliminary Check"](#).

C1729 VEHICLE SPEED SIGNAL

< DTC/CIRCUIT DIAGNOSIS >

C1729 VEHICLE SPEED SIGNAL

Description

INFOID:000000008642239

The vehicle speed signal is not being detected by the BCM.

DTC Logic

INFOID:000000008642240

NOTE:

The Signal Tech II Tool (J-50190) can be used to perform the following functions. Refer to the Signal Tech II User Guide for additional information.

- Activate and display TPMS transmitter IDs
- Display tire pressure reported by the TPMS transmitter
- Read TPMS DTCs
- Register TPMS transmitter IDs

DTC DETECTION LOGIC

DTC	CONSULT	DTC detecting condition
C1729	VHCL SPEED SIG ERR	Vehicle speed signal is in error.

DTC CONFIRMATION PROCEDURE

1. CHECK SELF-DIAGNOSTIC RESULTS

1. On "SELECT DIAG MODE", select the "SELF-DIAG RESULT" screen.
2. Check display contents on "SELF DIAG RESULT" screen.

Is the "CAN COMM CIRCUIT" displayed in the self-diagnosis display?

- YES >> Refer to [WT-19, "Diagnosis Procedure"](#).
NO >> Inspection End.

Diagnosis Procedure

INFOID:000000008642241

NOTE:

The Signal Tech II Tool (J-50190) can be used to perform the following functions. Refer to the Signal Tech II User Guide for additional information.

- Activate and display TPMS transmitter IDs
- Display tire pressure reported by the TPMS transmitter
- Read TPMS DTCs
- Register TPMS transmitter IDs

MALFUNCTION CODE NO. 52 (DTC C1729)

1. CHECK SELF-DIAGNOSTIC RESULTS

1. On "SELECT DIAG MODE", select the "SELF-DIAG RESULT" screen.
2. Check display contents on "SELF DIAG RESULT" screen.

Is the "CAN COMM CIRCUIT" displayed in the self-diagnosis display?

- YES >> Perform trouble diagnosis for CAN communication system. Refer to [LAN-15, "Trouble Diagnosis Flow Chart"](#).
NO >> Check combination meter. Refer to [MWI-29, "CONSULT Function \(METER/M&A\)"](#).

Special Repair Requirement

INFOID:000000008642242

Perform preliminary check. Refer to [WT-5, "Preliminary Check"](#).

C1734 CONTROL UNIT

< DTC/CIRCUIT DIAGNOSIS >

C1734 CONTROL UNIT

Description

INFOID:000000008642243

An internal malfunction has been detected in the TPMS function of the BCM.

DTC Logic

INFOID:000000008642244

NOTE:

The Signal Tech II Tool (J-50190) can be used to perform the following functions. Refer to the Signal Tech II User Guide for additional information.

- Activate and display TPMS transmitter IDs
- Display tire pressure reported by the TPMS transmitter
- Read TPMS DTCs
- Register TPMS transmitter IDs

DTC DETECTION LOGIC

DTC	CONSULT	DTC detecting condition
C1734	CONTROL UNIT	TPMS malfunction in BCM.

DTC CONFIRMATION PROCEDURE

1. CHECK SELF-DIAGNOSTIC RESULTS

1. On "SELECT DIAG MODE", select the "SELF-DIAG RESULT" screen.
2. Check display contents on "SELF DIAG RESULT" screen.

Is C1734 displayed in the self-diagnosis display?

- YES >> Refer to [WT-20, "Diagnosis Procedure"](#).
NO >> Inspection End.

Diagnosis Procedure

INFOID:000000008642245

NOTE:

The Signal Tech II Tool (J-50190) can be used to perform the following functions. Refer to the Signal Tech II User Guide for additional information.

- Activate and display TPMS transmitter IDs
- Display tire pressure reported by the TPMS transmitter
- Read TPMS DTCs
- Register TPMS transmitter IDs

Regarding Wiring Diagram information, refer to [WT-46, "Wiring Diagram"](#).

MALFUNCTION CODE NO. 53 (DTC C1734)

1. SELF-DIAGNOSTIC RESULTS

1. On "SELECT DIAG" mode, select the "SELF-DIAG RESULT" screen for BCM.
2. Check display contents on "SELF-DIAG RESULT".

Does self-diagnostic results indicate any DTC other than C1734?

- YES >> Perform trouble diagnosis for DTC. Refer to [BCS-64, "DTC Index"](#).
NO >> GO TO 2.

2. CHECK BCM HARNESS CONNECTORS

Check BCM harness connectors for damage or loose connections.

Are the BCM harness connectors damaged or loose?

- YES >> Repair or replace damaged parts.
NO >> GO TO 3.

3. BCM POWER SUPPLY AND GROUND

C1734 CONTROL UNIT

< DTC/CIRCUIT DIAGNOSIS >

Check BCM power supply and ground. Refer to [BCS-79. "Removal and Installation"](#).

Are the power supply and grounds normal?

- YES >> GO TO 4.
- NO >> Repair power supply or grounds as necessary.

4. CHECK HARNESS BETWEEN BCM AND TIRE PRESSURE RECEIVER

1. Turn ignition switch OFF.
2. Disconnect BCM harness connector and tire pressure receiver harness connector.
3. Check continuity between BCM harness connector M18 (A) and tire pressure receiver harness connector M70 (B).

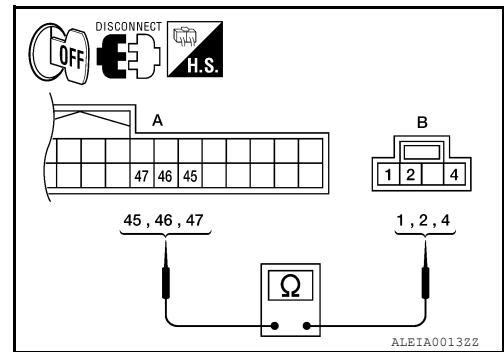

BCM		Tire pressure receiver		Continuity
Connector	Terminal	Connector	Terminal	
M18 (A)	45	M70 (B)	1	YES
	46		4	
	47		2	

Does continuity exist?

- YES >> GO TO 5.
- NO >> Repair circuits as necessary.

5. BCM INPUT/OUTPUT SIGNALS

Check BCM input/output signals. Refer to [BCS-41. "Reference Value"](#).

Are the inputs and outputs normal?

- YES >> Inspection End.
- NO >> Replace BCM. Refer to [BCS-79. "Removal and Installation"](#).

Special Repair Requirement

INFOID:000000008642246

Perform preliminary check. Refer to [WT-5. "Preliminary Check"](#).

BCM (BODY CONTROL MODULE)

< ECU DIAGNOSIS INFORMATION >

ECU DIAGNOSIS INFORMATION

BCM (BODY CONTROL MODULE)

Reference Value

INFOID:000000008788707

NOTE:

The Signal Tech II Tool (J-50190) can be used to perform the following functions. Refer to the Signal Tech II User Guide for additional information.

- Activate and display TPMS transmitter IDs
- Display tire pressure reported by the TPMS transmitter
- Read TPMS DTCs
- Register TPMS transmitter IDs
- Check Intelligent Key relative signal strength
- Confirm vehicle Intelligent Key antenna signal strength

VALUES ON THE DIAGNOSIS TOOL

Monitor Item	Condition	Value/Status
FR WIPER HI	Other than front wiper switch HI	OFF
	Front wiper switch HI	ON
FR WIPER LOW	Other than front wiper switch LO	OFF
	Front wiper switch LO	ON
FR WASHER SW	Front washer switch OFF	OFF
	Front washer switch ON	ON
FR WIPER INT	Other than front wiper switch INT	OFF
	Front wiper switch INT	ON
FR WIPER STOP	Front wiper is not in STOP position	OFF
	Front wiper is in STOP position	ON
INT VOLUME	Wiper intermittent dial is in a dial position 1 - 7	Wiper intermittent dial position
TURN SIGNAL R	Other than turn signal switch RH	OFF
	Turn signal switch RH	ON
TURN SIGNAL L	Other than turn signal switch LH	OFF
	Turn signal switch LH	ON
TAIL LAMP SW	Other than lighting switch 1ST and 2ND	OFF
	Lighting switch 1ST or 2ND	ON
HI BEAM SW	Other than lighting switch HI	OFF
	Lighting switch HI	ON
HEAD LAMP SW 1	Other than lighting switch 2ND	OFF
	Lighting switch 2ND	ON
HEAD LAMP SW 2	Other than lighting switch 2ND	OFF
	Lighting switch 2ND	ON
PASSING SW	Other than lighting switch PASS	OFF
	Lighting switch PASS	ON
AUTO LIGHT SW	Other than lighting switch AUTO	OFF
	Lighting switch AUTO	ON
FR FOG SW	Front fog lamp switch OFF	OFF
	Front fog lamp switch ON	ON
DOOR SW-DR	Driver door closed	OFF
	Driver door opened	ON

BCM (BODY CONTROL MODULE)

< ECU DIAGNOSIS INFORMATION >

Monitor Item	Condition	Value/Status	
DOOR SW-AS	Passenger door closed	OFF	A
	Passenger door opened	ON	
DOOR SW-RR	Rear door RH closed	OFF	B
	Rear door RH opened	ON	
DOOR SW-RL	Rear door LH closed	OFF	C
	Rear door LH opened	ON	
CDL LOCK SW	Other than power door lock switch LOCK	OFF	
	Power door lock switch LOCK	ON	D
CDL UNLOCK SW	Other than power door lock switch UNLOCK	OFF	
	Power door lock switch UNLOCK	ON	
KEY CYL LK-SW	Other than driver door key cylinder LOCK position	OFF	WT
	Driver door key cylinder LOCK position	ON	
KEY CYL UN-SW	Other than driver door key cylinder UNLOCK position	OFF	F
	Driver door key cylinder UNLOCK position	ON	
HAZARD SW	When hazard switch is not pressed	OFF	
	When hazard switch is pressed	ON	G
REAR DEF SW	When rear window defogger switch is pressed	ON	
TR CANCEL SW	Trunk lid opener cancel switch OFF	OFF	H
	Trunk lid opener cancel switch ON	ON	
TR/BD OPEN SW	Trunk lid opener switch OFF	OFF	
	While the trunk lid opener switch is turned ON	ON	I
TRNK/HAT MNTR	Trunk lid closed	OFF	J
	Trunk lid opened	ON	
RKE-LOCK	When LOCK button of Intelligent Key is not pressed	OFF	
	When LOCK button of Intelligent Key is pressed	ON	
RKE-UNLOCK	When UNLOCK button of Intelligent Key is not pressed	OFF	K
	When UNLOCK button of Intelligent Key is pressed	ON	
RKE-TR/BD	When TRUNK OPEN button of Intelligent Key is not pressed	OFF	L
	When TRUNK OPEN button of Intelligent Key is pressed	ON	
RKE-PANIC	When PANIC button of Intelligent Key is not pressed	OFF	M
	When PANIC button of Intelligent Key is pressed	ON	
RKE-P/W OPEN	When UNLOCK button of Intelligent Key is not pressed and held	OFF	
	When UNLOCK button of Intelligent Key is pressed and held	ON	
RKE-MODE CHG	When LOCK/UNLOCK button of Intelligent Key is not pressed and held simultaneously	OFF	N
	When LOCK/UNLOCK button of Intelligent Key is pressed and held simultaneously	ON	O
OPTICAL SENSOR	When outside of the vehicle is bright	Close to 5 V	
	When outside of the vehicle is dark	Close to 0 V	
REQ SW -DR	When front door request switch is not pressed (driver side)	OFF	P
	When front door request switch is pressed (driver side)	ON	
REQ SW -AS	When front door request switch is not pressed (passenger side)	OFF	
	When front door request switch is pressed (passenger side)	ON	
REQ SW -RL	When rear door request switch is not pressed (driver side)	OFF	
	When rear door request switch is pressed (driver side)	ON	

BCM (BODY CONTROL MODULE)

< ECU DIAGNOSIS INFORMATION >

Monitor Item	Condition	Value/Status
REQ SW -RR	When rear door request switch is not pressed (passenger side)	OFF
	When rear door request switch is pressed (passenger side)	ON
REQ SW -BD/TR	When trunk request switch is not pressed	OFF
	When trunk request switch is pressed	ON
PUSH SW	When engine switch (push switch) is not pressed	OFF
	When engine switch (push switch) is pressed	ON
IGN RLY2 -F/B	Ignition switch OFF or ACC	OFF
	Ignition switch ON	ON
ACC RLY -F/B	Ignition switch OFF	OFF
	Ignition switch ACC or ON	ON
BRAKE SW 1	When the brake pedal is not depressed	ON
	When the brake pedal is depressed	OFF
DETE/CANCL SW	When selector lever is in P position	OFF
	When selector lever is in any position other than P	ON
SFT PN/N SW	When selector lever is in any position other than P or N	OFF
	When selector lever is in P or N position	ON
UNLK SEN -DR	Driver door UNLOCK status	OFF
	Driver door LOCK status	ON
PUSH SW -IPDM	When engine switch (push switch) is not pressed	OFF
	When engine switch (push switch) is pressed	ON
IGN RLY1 -F/B	Ignition switch OFF or ACC	OFF
	Ignition switch ON	ON
DETE SW -IPDM	When selector lever is in P position	OFF
	When selector lever is in any position other than P	ON
SFT PN -IPDM	When selector lever is in any position other than P or N	OFF
	When selector lever is in P or N position	ON
SFT P -MET	When selector lever is in any position other than P	OFF
	When selector lever is in P position	ON
SFT N -MET	When selector lever is in any position other than N	OFF
	When selector lever is in N position	ON
ENGINE STATE	Engine stopped	STOP
	While the engine stalls	STALL
	At engine cranking	CRANK
	Engine running	RUN
VEH SPEED 1	While driving	Equivalent to speedometer reading
VEH SPEED 2	While driving	Equivalent to speedometer reading
DOOR STAT-DR	Driver door LOCK status	LOCK
	Wait with selective UNLOCK operation (5 seconds)	READY
	Driver door UNLOCK status	UNLK
DOOR STAT-AS	Passenger door LOCK status	LOCK
	Wait with selective UNLOCK operation (5 seconds)	READY
	Passenger door UNLOCK status	UNLK
ID OK FLAG	Ignition switch ACC or ON	RESET
	Ignition switch OFF	SET

BCM (BODY CONTROL MODULE)

< ECU DIAGNOSIS INFORMATION >

Monitor Item	Condition	Value/Status	
PRMT ENG STRT	When the engine start is prohibited	RESET	A
	When the engine start is permitted	SET	
KEY SW -SLOT	When Intelligent Key is not inserted into key slot	OFF	B
	When Intelligent Key is inserted into key slot	ON	
RKE OPE COUN1	During the operation of Intelligent Key	Operation frequency of Intelligent Key	
CONFIRM ID ALL	The key ID that the key slot receives does not accord with any key ID registered to BCM.	YET	C
	The key ID that the key slot receives accords with any key ID registered to BCM.	DONE	D
CONFIRM ID4	The key ID that the key slot receives does not accord with the fourth key ID registered to BCM.	YET	WT
	The key ID that the key slot receives accords with the fourth key ID registered to BCM.	DONE	
CONFIRM ID3	The key ID that the key slot receives does not accord with the third key ID registered to BCM.	YET	F
	The key ID that the key slot receives accords with the third key ID registered to BCM.	DONE	
CONFIRM ID2	The key ID that the key slot receives does not accord with the second key ID registered to BCM.	YET	G
	The key ID that the key slot receives accords with the second key ID registered to BCM.	DONE	H
CONFIRM ID1	The key ID that the key slot receives does not accord with the first key ID registered to BCM.	YET	I
	The key ID that the key slot receives accords with the first key ID registered to BCM.	DONE	
TP 4	The ID of fourth key is not registered to BCM	YET	J
	The ID of fourth key is registered to BCM	DONE	
TP 3	The ID of third key is not registered to BCM	YET	K
	The ID of third key is registered to BCM	DONE	
TP 2	The ID of second key is not registered to BCM	YET	L
	The ID of second key is registered to BCM	DONE	
TP 1	The ID of first key is not registered to BCM	YET	M
	The ID of first key is registered to BCM	DONE	
AIR PRESS FL	Ignition switch ON (only when the signal from the transmitter is received)	Air pressure of front LH tire	
AIR PRESS FR	Ignition switch ON (only when the signal from the transmitter is received)	Air pressure of front RH tire	
AIR PRESS RR	Ignition switch ON (only when the signal from the transmitter is received)	Air pressure of rear RH tire	N
AIR PRESS RL	Ignition switch ON (only when the signal from the transmitter is received)	Air pressure of rear LH tire	O
ID REGST FL1	When ID of front LH tire transmitter is registered	DONE	P
	When ID of front LH tire transmitter is not registered	YET	
ID REGST FR1	When ID of front RH tire transmitter is registered	DONE	
	When ID of front RH tire transmitter is not registered	YET	
ID REGST RR1	When ID of rear RH tire transmitter is registered	DONE	
	When ID of rear RH tire transmitter is not registered	YET	
ID REGST RL1	When ID of rear LH tire transmitter is registered	DONE	
	When ID of rear LH tire transmitter is not registered	YET	

BCM (BODY CONTROL MODULE)

< ECU DIAGNOSIS INFORMATION >

Monitor Item	Condition	Value/Status
WARNING LAMP	Tire pressure indicator OFF	OFF
	Tire pressure indicator ON	ON
BUZZER	Tire pressure warning alarm is not sounding	OFF
	Tire pressure warning alarm is sounding	ON

BCM (BODY CONTROL MODULE)

< ECU DIAGNOSIS INFORMATION >

Terminal Layout

INFOID:000000008788708

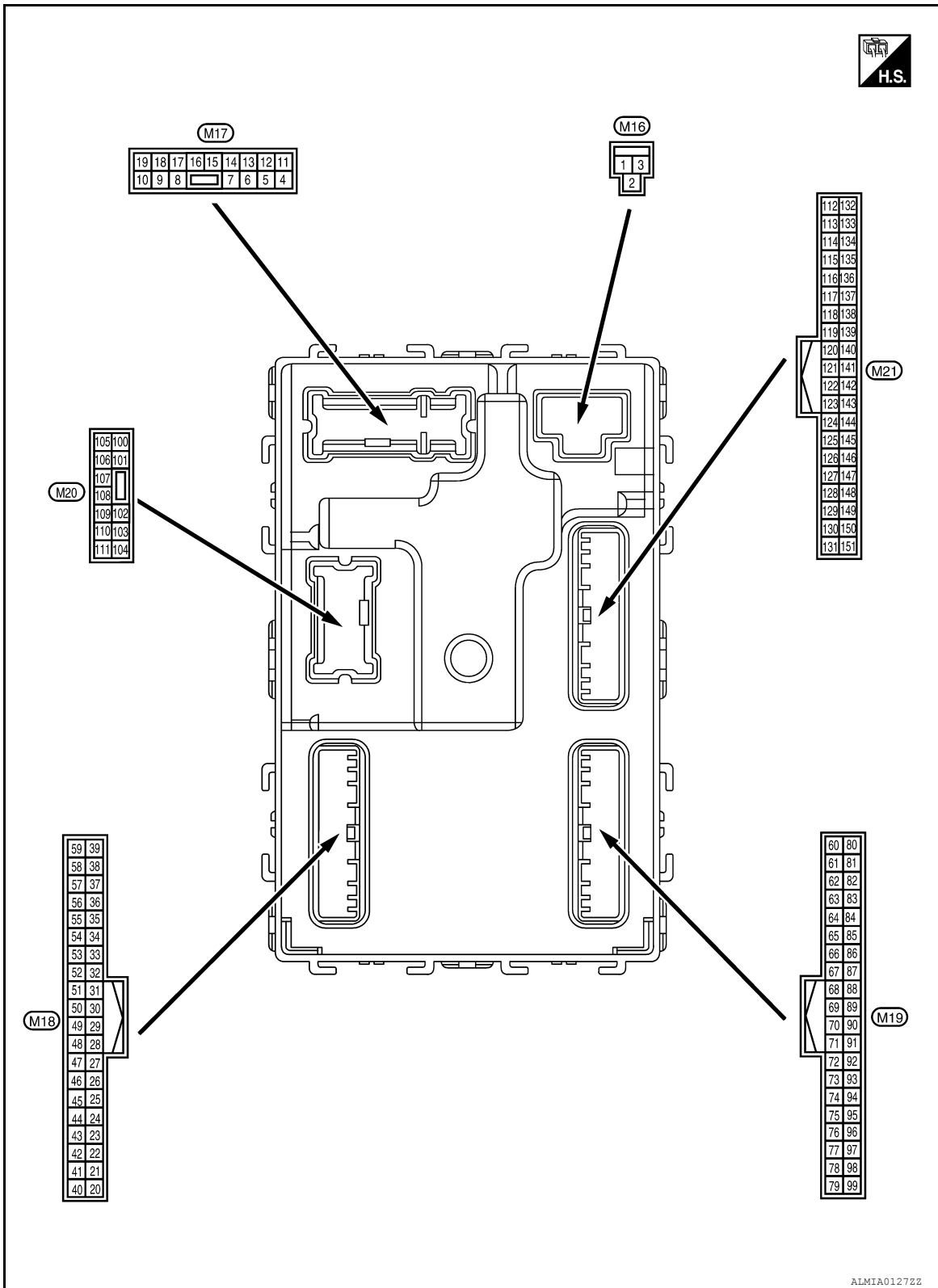

A
B
C
D
WT
F
G
H
I
J
K
L
M
N
O
P

Physical Values

INFOID:000000008788709

BCM (BODY CONTROL MODULE)

< ECU DIAGNOSIS INFORMATION >

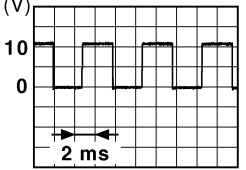
Terminal No. (Wire color)		Description		Condition		Value (Approx.)
		Signal name	Input/ Output			
(+)	(-)					
1 (W/B)	Ground	Battery power supply	Input	Ignition switch OFF		Battery voltage
2 (R/Y)	Ground	Battery power supply output	Output	Ignition switch OFF		Battery voltage
3 (L/W)	Ground	Ignition power supply output	Output	Ignition switch ON		Battery voltage
4 (P/W)	Ground	Interior room lamp power supply	Output	After passing the interior room lamp battery saver operation time		0V
				Any other time after passing the interior room lamp battery saver operation time		Battery voltage
5 (G)	Ground	Front door RH UNLOCK	Output	Front door RH	UNLOCK (actuator is activated)	Battery voltage
					Other than UNLOCK (actuator is not activated)	0V
7 (R/W)	Ground	Step lamp	Output	Step lamp	ON	0V
					OFF	Battery voltage
8 (V)	Ground	All doors LOCK	Output	All doors	LOCK (actuator is activated)	Battery voltage
					Other than LOCK (actuator is not activated)	0V
9 (L)	Ground	Front door LH UNLOCK	Output	Front door LH	UNLOCK (actuator is activated)	Battery voltage
					Other than UNLOCK (actuator is not activated)	0V
10 (G)	Ground	Rear door RH and rear door LH UNLOCK	Output	Rear door RH and rear door LH	UNLOCK (actuator is activated)	Battery voltage
					Other than UNLOCK (actuator is not activated)	0V
11 (Y/R)	Ground	Battery power supply	Input	Ignition switch OFF		Battery voltage
13 (B)	Ground	Ground	—	Ignition switch ON		0V
14 (GR/W)	Ground	Engine switch (push switch) illumination ground	Input	Tail lamp	OFF	0V
					ON	<p>NOTE: When the illumination brightening/dimming level is in the neutral position</p>  <p style="text-align: right; font-size: small;">JSNIA0010GB</p>
15 (Y/L)	Ground	ACC indicator lamp	Output	Ignition switch	OFF	Battery voltage
					ACC or ON	0V

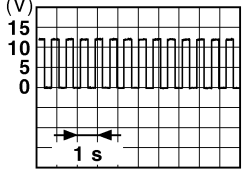
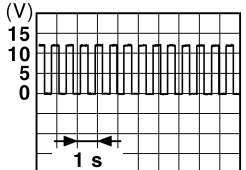
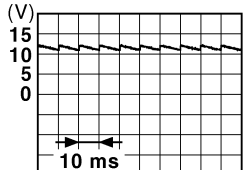

BCM (BODY CONTROL MODULE)

< ECU DIAGNOSIS INFORMATION >

Terminal No. (Wire color)		Description		Condition		Value (Approx.)
(+)	(-)	Signal name	Input/ Output			
17 (G/B)	Ground	Turn signal (RH)	Output	Ignition switch ON	Turn signal switch OFF	0V
					Turn signal switch RH	 <p style="text-align: center;">6.5 V</p>
18 (G/Y)	Ground	Turn signal (LH)	Output	Ignition switch ON	Turn signal switch OFF	0V
					Turn signal switch LH	 <p style="text-align: center;">6.5 V</p>
19 (Y)	Ground	Room lamp timer control	Output	Interior room lamp	OFF	Battery voltage
					ON	0V
21 (P/B)	Ground	Optical sensor signal	Input	Ignition switch ON	When outside of the vehi- cle is bright	Close to 5V
					When outside of the vehi- cle is dark	Close to 0V
24 (R/W)	Ground	Stop lamp switch 1	Input	—	Battery voltage	
26 (O/L)	Ground	Stop lamp switch 2	Input	Stop lamp switch	OFF (brake pedal is re- leased)	0V
					ON (brake pedal is de- pressed)	Battery voltage
27 (O)	Ground	Front door lock as- sembly LH (unlock sensor)	Input	Front door LH	LOCK status	 <p style="text-align: center;">11.8V</p>
					UNLOCK status	0V
29 (Y)	Ground	Key slot switch	Input	When Intelligent Key is inserted into key slot	Battery voltage	
				When Intelligent Key is not inserted into key slot	0V	
31 (G)	Ground	Rear window defog- ger feedback signal	Input	Rear window de- fogger switch	OFF	0V
				ON	Battery voltage	

BCM (BODY CONTROL MODULE)

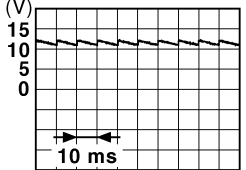
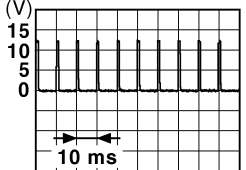
< ECU DIAGNOSIS INFORMATION >

Terminal No. (Wire color)		Description		Condition		Value (Approx.)
(+)	(-)	Signal name	Input/ Output			
32 (R/B)	Ground	Front door RH switch	Input	Front door RH switch	OFF (when front door RH closes)	 <p style="text-align: right; font-size: small;">JPMIA0011GB</p> <p style="text-align: center;">11.8 V</p>
					ON (when front door RH opens)	0V
37 (O)	Ground	Trunk lid opener cancel switch	Input	Trunk lid opener cancel switch	CANCEL	 <p style="text-align: right; font-size: small;">JPMIA0012GB</p> <p style="text-align: center;">1.1V</p>
					ON	0V
38 (GR/W)	Ground	Rear window defogger ON signal	Input	Rear window defogger switch	OFF	5V
					ON	0V
40 (Y/G)	Ground	Power window serial link	Input/ Output	Ignition switch ON	 <p style="text-align: right; font-size: small;">JPMIA0013GB</p> <p style="text-align: center;">10.2V</p>	
				Ignition switch OFF or ACC	0V	
41 (W)	Ground	Engine switch (push switch) illumination	Output	Engine switch (push switch) illumination	ON	5.5V
					OFF	0V
42 (R)	Ground	LOCK indicator lamp	Output	LOCK indicator lamp	ON	0V
					OFF	Battery voltage
45 (P)	Ground	Receiver & sensor ground	Input	Ignition switch ON	0V	
46 (V/W)	Ground	Receiver & sensor power supply output	Output	Ignition switch	OFF	0V
					ACC or ON	5.0V

BCM (BODY CONTROL MODULE)

< ECU DIAGNOSIS INFORMATION >

Terminal No. (Wire color)		Description		Condition	Value (Approx.)							
(+)	(-)	Signal name	Input/ Output									
47 (G/O)	Ground	Tire pressure receiver signal	Input/ Output	Ignition switch ON	<p style="text-align: right;">OCC3881D</p>							
				When receiving the signal from the transmitter	<p style="text-align: right;">OCC3880D</p>							
48 (R/G)	Ground	Selector lever transmission range switch signal	Input	Selector lever	<table border="1"> <tr> <td>P or N position</td> <td>12.0V</td> </tr> <tr> <td>Except P and N positions</td> <td>0V</td> </tr> </table>	P or N position	12.0V	Except P and N positions	0V			
				P or N position	12.0V							
Except P and N positions	0V											
49 (L/O)	Ground	Security indicator signal	Output	Security indicator	<table border="1"> <tr> <td>ON</td> <td>0V</td> </tr> <tr> <td>Blinking</td> <td> <p style="text-align: right;">JPMIA0014GB</p> <p style="text-align: center;">11.3V</p> </td> </tr> </table>	ON	0V	Blinking	<p style="text-align: right;">JPMIA0014GB</p> <p style="text-align: center;">11.3V</p>			
				ON	0V							
Blinking	<p style="text-align: right;">JPMIA0014GB</p> <p style="text-align: center;">11.3V</p>											
50 (LG/B)	Ground	Combination switch OUTPUT 5	Input	Combination switch (Wiper intermittent dial 4)	<table border="1"> <tr> <td>All switch OFF</td> <td>0V</td> </tr> <tr> <td>Lighting switch 1ST</td> <td rowspan="4"> <p style="text-align: right;">JPMIA0031GB</p> <p style="text-align: center;">10.7V</p> </td> </tr> <tr> <td>Lighting switch high-beam</td> </tr> <tr> <td>Lighting switch 2ND</td> </tr> <tr> <td>Turn signal switch RH</td> </tr> </table>	All switch OFF	0V	Lighting switch 1ST	<p style="text-align: right;">JPMIA0031GB</p> <p style="text-align: center;">10.7V</p>	Lighting switch high-beam	Lighting switch 2ND	Turn signal switch RH
				All switch OFF	0V							
				Lighting switch 1ST	<p style="text-align: right;">JPMIA0031GB</p> <p style="text-align: center;">10.7V</p>							
				Lighting switch high-beam								
				Lighting switch 2ND								
Turn signal switch RH												
51 (L/W)	Ground	Combination switch OUTPUT 1	Input	Combination switch	<table border="1"> <tr> <td>All switch OFF (Wiper intermittent dial 4)</td> <td>0V</td> </tr> <tr> <td>Front wiper switch HI (Wiper intermittent dial 4)</td> <td rowspan="2"> <p style="text-align: right;">JPMIA0032GB</p> <p style="text-align: center;">10.7V</p> </td> </tr> <tr> <td>Any of the conditions below with all switch OFF <ul style="list-style-type: none"> • Wiper intermittent dial 1 • Wiper intermittent dial 2 • Wiper intermittent dial 3 • Wiper intermittent dial 6 • Wiper intermittent dial 7 </td> </tr> </table>	All switch OFF (Wiper intermittent dial 4)	0V	Front wiper switch HI (Wiper intermittent dial 4)	<p style="text-align: right;">JPMIA0032GB</p> <p style="text-align: center;">10.7V</p>	Any of the conditions below with all switch OFF <ul style="list-style-type: none"> • Wiper intermittent dial 1 • Wiper intermittent dial 2 • Wiper intermittent dial 3 • Wiper intermittent dial 6 • Wiper intermittent dial 7 		
				All switch OFF (Wiper intermittent dial 4)	0V							
Front wiper switch HI (Wiper intermittent dial 4)	<p style="text-align: right;">JPMIA0032GB</p> <p style="text-align: center;">10.7V</p>											
Any of the conditions below with all switch OFF <ul style="list-style-type: none"> • Wiper intermittent dial 1 • Wiper intermittent dial 2 • Wiper intermittent dial 3 • Wiper intermittent dial 6 • Wiper intermittent dial 7 												

A

B

C

D

WT

F

G

H

I

J

K

L

M

N

O

P

BCM (BODY CONTROL MODULE)

< ECU DIAGNOSIS INFORMATION >

Terminal No. (Wire color)		Description		Condition	Value (Approx.)	
(+)	(-)	Signal name	Input/ Output			
52 (G/B)	Ground	Combination switch OUTPUT 2	Input	Combination switch	All switch OFF (Wiper intermittent dial 4)	0V
					Front washer switch ON (Wiper intermittent dial 4)	<p style="text-align: right; font-size: small;">JPMIA0033GB</p>
					Any of the conditions below with all switch OFF	
					<ul style="list-style-type: none"> • Wiper intermittent dial 1 • Wiper intermittent dial 5 • Wiper intermittent dial 6 	
					10.7V	
53 (LG/ R)	Ground	Combination switch OUTPUT 3	Input	Combination switch (Wiper intermit- tent dial 4)	All switch OFF	0V
					Front wiper switch INT	<p style="text-align: right; font-size: small;">JPMIA0034GB</p>
					Front wiper switch LO	
					Lighting switch AUTO	
					10.7V	
54 (G/Y)	Ground	Combination switch OUTPUT 4	Input	Combination switch (Wiper intermit- tent dial 4)	All switch OFF	0V
					Front fog lamp switch ON	<p style="text-align: right; font-size: small;">JPMIA0035GB</p>
					Lighting switch 2ND	
					Lighting switch flash-to- pass	
					10.7V	
57 (W)	Ground	Tire pressure warn- ing check switch	Input	—	5V	
58 (SB)	Ground	Front door LH switch	Input	Front door LH switch	OFF (front door LH CLOSE)	<p style="text-align: right; font-size: small;">JPMIA0011GB</p>
					ON (front door LH OPEN)	
59 (G/R)	Ground	Rear window defog- ger relay	Output	Rear window de- fogger	Active	Battery voltage
				Not activated	0V	

BCM (BODY CONTROL MODULE)

< ECU DIAGNOSIS INFORMATION >

Terminal No. (Wire color)		Description		Condition	Value (Approx.)
(+)	(-)	Signal name	Input/ Output		
60 (B/R)	Ground	Front console antenna 2 (-)	Output	Ignition switch OFF	<p style="text-align: right; font-size: small;">JMKIA0062GB</p>
				When Intelligent Key is not in the passenger compartment	<p style="text-align: right; font-size: small;">JMKIA0063GB</p>
61 (W/R)	Ground	Center console antenna 2 (+)	Output	Ignition switch OFF	<p style="text-align: right; font-size: small;">JMKIA0062GB</p>
				When Intelligent Key is not in the passenger compartment	<p style="text-align: right; font-size: small;">JMKIA0063GB</p>
62 (V)	Ground	Front outside handle RH antenna (-)	Output	When the front door RH request switch is operated with ignition switch OFF	<p style="text-align: right; font-size: small;">JMKIA0062GB</p>
				When Intelligent Key is not in the antenna detection area	<p style="text-align: right; font-size: small;">JMKIA0063GB</p>

A
B
C
D
WT
F
G
H
I
J
K
L
M
N
O
P

BCM (BODY CONTROL MODULE)

< ECU DIAGNOSIS INFORMATION >

Terminal No. (Wire color)		Description		Condition	Value (Approx.)
(+)	(-)	Signal name	Input/ Output		
63 (P)	Ground	Front outside handle RH antenna (+)	Output	When Intelligent Key is in the antenna detection area	<p style="text-align: right; font-size: small;">JMKIA0062GB</p>
				When the front door RH request switch is operat- ed with ignition switch OFF	<p style="text-align: right; font-size: small;">JMKIA0063GB</p>
64 (V)	Ground	Front outside handle LH antenna (-)	Output	When Intelligent Key is in the antenna detection area	<p style="text-align: right; font-size: small;">JMKIA0062GB</p>
				When the front door LH request switch is operat- ed with ignition switch OFF	<p style="text-align: right; font-size: small;">JMKIA0063GB</p>
65 (P)	Ground	Front outside handle LH antenna (+)	Output	When Intelligent Key is in the antenna detection area	<p style="text-align: right; font-size: small;">JMKIA0062GB</p>
				When the front door LH request switch is operat- ed with ignition switch OFF	<p style="text-align: right; font-size: small;">JMKIA0063GB</p>

BCM (BODY CONTROL MODULE)

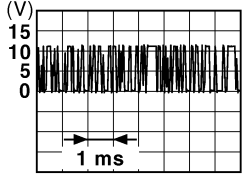
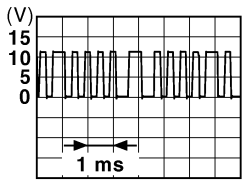
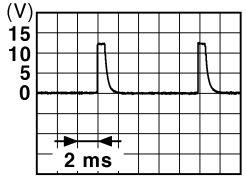
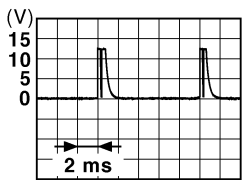
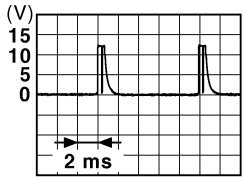

< ECU DIAGNOSIS INFORMATION >

Terminal No. (Wire color)		Description		Condition		Value (Approx.)
(+)	(-)	Signal name	Input/ Output			
68 (G/O)	Ground	NATS antenna amp (built in key slot)	Input/ Output	During waiting	Ignition switch is pressed while inserting the Intelli- gent Key into the key slot.	Just after pressing ignition switch. Pointer of tester should move.
69 (O)	Ground	NATS antenna amp (built in key slot)	Input/ Output	During waiting	Ignition switch is pressed while inserting the Intelli- gent Key into the key slot.	Just after pressing ignition switch. Pointer of tester should move.
70 (R/B)	Ground	Ignition relay-2 con- trol	Output	Ignition switch	OFF or ACC	0V
					ON	Battery voltage
71 (L/O)	Ground	Remote keyless entry receiver signal	Input/ Output	During waiting		 <p style="text-align: right; font-size: small;">JMKIA0064GB</p>
				When operating either button on Intelligent Key		 <p style="text-align: right; font-size: small;">JMKIA0065GB</p>
75 (R/Y)	Ground	Combination switch INPUT 5	Output	Combination switch	All switch OFF (Wiper intermittent dial 4)	 <p style="text-align: right; font-size: small;">JPMIA0041GB</p> <p style="text-align: center;">1.4V</p>
					Front fog lamp switch ON (Wiper intermittent dial 4)	 <p style="text-align: right; font-size: small;">JPMIA0037GB</p> <p style="text-align: center;">1.3V</p>
					Any of the conditions below with all switch OFF • Wiper intermittent dial 1 • Wiper intermittent dial 2 • Wiper intermittent dial 6 • Wiper intermittent dial 7	 <p style="text-align: right; font-size: small;">JPMIA0040GB</p> <p style="text-align: center;">1.3V</p>

A
B
C
D
WT
F
G
H
I
J
K
L
M
N
O
P

BCM (BODY CONTROL MODULE)

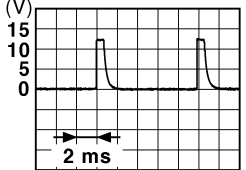
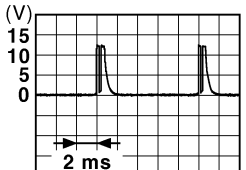
< ECU DIAGNOSIS INFORMATION >

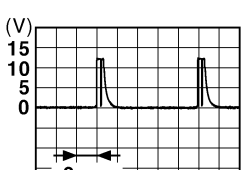
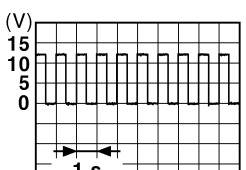
Terminal No. (Wire color)		Description		Condition	Value (Approx.)
(+)	(-)	Signal name	Input/ Output		
76 (R/G)	Ground	Combination switch INPUT 3	Output	Combination switch	All switch OFF (Wiper intermittent dial 4)  JPMIA0041GB 1.4V
					Lighting switch high-beam (Wiper intermittent dial 4)  JPMIA0036GB 1.3V
					Lighting switch 2ND (Wiper intermittent dial 4)  JPMIA0037GB 1.3V
					Any of the conditions below with all switch OFF • Wiper intermittent dial 1 • Wiper intermittent dial 2 • Wiper intermittent dial 3  JPMIA0040GB 1.3V
78 (P)	Ground	CAN-L	Input/ Output	—	—
79 (L)	Ground	CAN-H	Input/ Output	—	—
80 (R/L)	Ground	Key slot illumination	Output	Key slot illumina- tion	OFF Battery voltage
					Blinking  JPMIA0015GB 6.5V
81 (LG)	Ground	ON indicator lamp	Output	Ignition switch	ON 0V
					OFF or ACC Battery voltage

BCM (BODY CONTROL MODULE)



< ECU DIAGNOSIS INFORMATION >

Terminal No. (Wire color)		Description		Condition		Value (Approx.)
(+)	(-)	Signal name	Input/ Output			
83 (L)	Ground	ACC relay control	Output	Ignition switch	OFF	0V
					ACC or ON	Battery voltage
84 (Y/R)	Ground	CVT shift selector	Output	—		Battery voltage
87 (G/B)	Ground	Selector lever P position switch	Input	Selector lever	P position	0V
					Any position other than P	Battery voltage
88 (R)	Ground	Front door RH request switch	Input	Front door RH request switch	ON (pressed)	0V
					OFF (not pressed)	<p style="text-align: center;">1.0V</p>
89 (R)	Ground	Front door LH request switch	Input	Front door LH request switch	ON (pressed)	0V
					OFF (not pressed)	<p style="text-align: center;">1.0V</p>
90 (Y)	Ground	Blower fan motor relay control	Output	Ignition switch	OFF or ACC	0V
					ON	Battery voltage
91 (L/R)	Ground	Remote keyless entry receiver power supply	Output	Ignition switch OFF		Battery voltage

A
B
C
D
WT
F
G
H
I
J
K
L
M
N
O
P

BCM (BODY CONTROL MODULE)

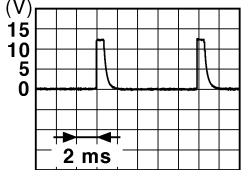
< ECU DIAGNOSIS INFORMATION >

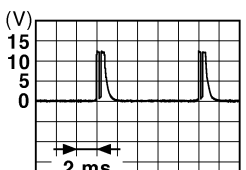
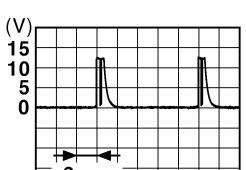
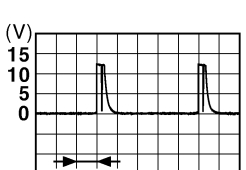
Terminal No. (Wire color)		Description		Condition	Value (Approx.)
(+)	(-)	Signal name	Input/ Output		
95 (R/W)	Ground	Combination switch INPUT 1	Output	Combination switch (Wiper intermittent dial 4)	All switch OFF <div style="text-align: right;">  <p>1.4V</p> </div>
					Turn signal switch LH <div style="text-align: right;">  <p>1.3V</p> </div>
					Turn signal switch RH <div style="text-align: right;">  <p>1.3V</p> </div>
					Front wiper switch LO <div style="text-align: right;">  <p>1.3V</p> </div>
					Front washer switch ON <div style="text-align: right;">  <p>1.3V</p> </div>

BCM (BODY CONTROL MODULE)

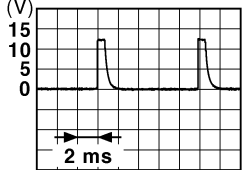
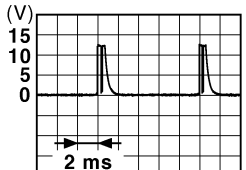
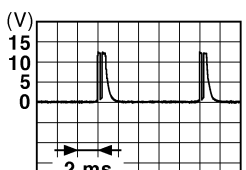
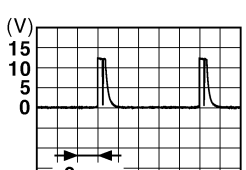

< ECU DIAGNOSIS INFORMATION >

Terminal No. (Wire color)		Description		Condition	Value (Approx.)
(+)	(-)	Signal name	Input/ Output		
96 (P/B)	Ground	Combination switch INPUT 4	Output Combination switch	All switch OFF (Wiper intermittent dial 4)	 <p style="text-align: right;">1.4V</p>
				Lighting switch AUTO (Wiper intermittent dial 4)	 <p style="text-align: right;">1.3V</p>
				Lighting switch 1ST (Wiper intermittent dial 4)	 <p style="text-align: right;">1.3V</p>
				Any of the conditions below with all switch OFF	<ul style="list-style-type: none"> • Wiper intermittent dial 1 • Wiper intermittent dial 5 • Wiper intermittent dial 6  <p style="text-align: right;">1.3V</p>

A
B
C
D
WT
F
G
H
I
J
K
L
M
N
O
P

BCM (BODY CONTROL MODULE)

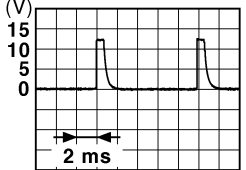
< ECU DIAGNOSIS INFORMATION >

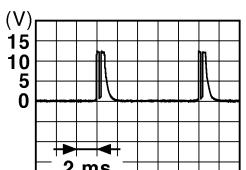
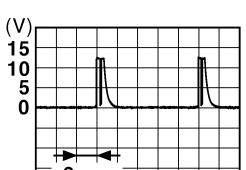
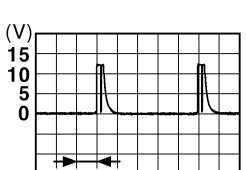
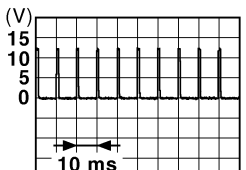
Terminal No. (Wire color)		Description		Condition	Value (Approx.)	
(+)	(-)	Signal name	Input/ Output			
97 (R/B)	Ground	Combination switch INPUT 2	Output	Combination switch (Wiper intermittent dial 4)	All switch OFF	 <p style="text-align: right;">1.4V</p>
					Lighting switch flash-to-pass	 <p style="text-align: right;">1.3V</p>
					Lighting switch 2ND	 <p style="text-align: right;">1.3V</p>
					Front wiper switch INT	 <p style="text-align: right;">1.3V</p>
					Front wiper switch HI	 <p style="text-align: right;">1.3V</p>
					Pressed	0 V
98 (G/O)	Ground	Hazard switch	Input	Hazard switch	Not pressed	 <p style="text-align: right;">1.1V</p>

BCM (BODY CONTROL MODULE)

< ECU DIAGNOSIS INFORMATION >

Terminal No. (Wire color)		Description		Condition	Value (Approx.)	
(+)	(-)	Signal name	Input/ Output			
103 (V)	Ground	Trunk lid opening.	Output	Trunk lid	Open (trunk lid opener actuator is activated)	Battery voltage
					Close (trunk lid opener actuator is not activated)	0V
110 (V/W)	Ground	Trunk room lamp	Output	Trunk room lamp	ON	0V
					OFF	Battery voltage
114 (B)	Ground	Trunk room antenna 1 (-)	Output	Ignition switch OFF	When Intelligent Key is in the passenger compartment	
					When Intelligent Key is not in the passenger compartment	
115 (W)	Ground	Trunk room antenna 1 (+)	Output	Ignition switch OFF	When Intelligent Key is in the passenger compartment	
					When Intelligent Key is not in the passenger compartment	

A
B
C
D
E
F
G
H
I
J
K
L
M
N
O
P

WT

BCM (BODY CONTROL MODULE)

< ECU DIAGNOSIS INFORMATION >

Terminal No. (Wire color)		Description		Condition	Value (Approx.)
(+)	(-)	Signal name	Input/ Output		
118 (L/O)	Ground	Rear bumper antenna (-)	Output	When the trunk lid request switch is operated with ignition switch OFF	<p style="text-align: right; font-size: small;">JMKIA0062GB</p>
				When Intelligent Key is not in the antenna detection area	<p style="text-align: right; font-size: small;">JMKIA0063GB</p>
119 (BR/W)	Ground	Rear bumper antenna (+)	Output	When the trunk lid request switch is operated with ignition switch OFF	<p style="text-align: right; font-size: small;">JMKIA0062GB</p>
				When Intelligent Key is not in the antenna detection area	<p style="text-align: right; font-size: small;">JMKIA0063GB</p>
127 (BR/W)	Ground	Ignition relay (IPDM E/R) control	Output	Ignition switch	OFF or ACC Battery voltage ON 0V
130 (W)	Ground	Trunk room lamp switch	Input	Trunk room lamp switch	<p style="text-align: right; font-size: small;">JPMIA0011GB</p> <p style="text-align: center;">11.8V</p>
				ON (trunk is open)	0V
132 (R)	Ground	Starter motor relay control	Output	Ignition switch ON	When selector lever is in P or N position and the brake is depressed Battery voltage When selector lever is in P or N position and the brake is not depressed 0V

BCM (BODY CONTROL MODULE)

< ECU DIAGNOSIS INFORMATION >

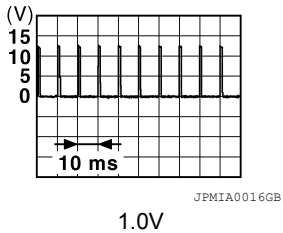
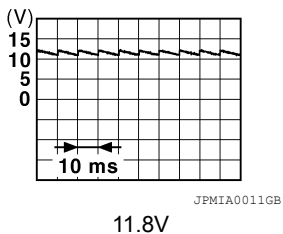
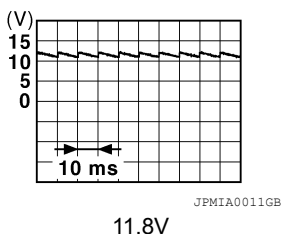
Terminal No. (Wire color)		Description		Condition	Value (Approx.)
(+)	(-)	Signal name	Input/ Output		
140 (BR)	Ground	Engine switch (push switch)	Input	Engine switch (push switch)	Pressed 0V
				Not pressed Battery voltage	
141 (BR)	Ground	Trunk request switch	Input	Trunk request switch	ON (pressed) 0V
				OFF (not pressed)	
144 (GR)	Ground	Request switch buzzer	Output	Request switch buzzer	Sounding 0V
				Not sounding Battery voltage	
147 (L/R)	Ground	Trunk lid opener switch	Input	Trunk lid opener switch	Pressed 0V
				Not pressed Battery voltage	
148 (R/W)	Ground	Rear door RH switch	Input	Rear door RH switch	OFF (when rear door RH closes)
				ON (when rear door RH opens)	
149 (R/B)	Ground	Rear door LH switch	Input	Rear door LH switch	OFF (when rear door LH closes)
				ON (when rear door LH opens)	

Self-Diagnosis (With CONSULT)

INFOID:000000008642250

NOTE:

The Signal Tech II Tool (J-50190) can be used to perform the following functions. Refer to the Signal Tech II User Guide for additional information.

- Activate and display TPMS transmitter IDs
- Display tire pressure reported by the TPMS transmitter
- Read TPMS DTCs
- Register TPMS transmitter IDs

FUNCTION

Self-Diagnostic Results Mode

BCM (BODY CONTROL MODULE)

< ECU DIAGNOSIS INFORMATION >

Diagnostic item	Diagnostic item is detected when ...	Reference page
LOW - PRESSURE - FL [C1704] LOW - PRESSURE - FR [C1705] LOW - PRESSURE - RR [C1706] LOW - PRESSURE - RL [C1707]	Tire pressures dropped below specified value. Refer to WT-8 , " System Description ".	—
[NO-DATA] - FL [C1708] [NO-DATA] - FR [C1709] [NO-DATA] - RR [C1710] [NO-DATA] - RL [C1711]	Data from FL transmitter cannot be received. Data from FR transmitter cannot be received. Data from RR transmitter cannot be received. Data from RL transmitter cannot be received.	WT-13
[CHECKSUM- ERR] - FL [C1712] [CHECKSUM- ERR] - FR [C1713] [CHECKSUM- ERR] - RR [C1714] [CHECKSUM- ERR] - RL [C1715]	Checksum data from FL transmitter is malfunctioning. Checksum data from FR transmitter is malfunctioning. Checksum data from RR transmitter is malfunctioning. Checksum data from RL transmitter is malfunctioning.	WT-15
[PRESSDATA- ERR] - FL [C1716] [PRESSDATA- ERR] - FR [C1717] [PRESSDATA- ERR] - RR [C1718] [PRESSDATA- ERR] - RL [C1719]	Air pressure data from FL transmitter is malfunctioning. Air pressure data from FR transmitter is malfunctioning. Air pressure data from RR transmitter is malfunctioning. Air pressure data from RL transmitter is malfunctioning.	WT-17
[CODE- ERR] - FL [C1720] [CODE- ERR] - FR [C1721] [CODE- ERR] - RR [C1722] [CODE- ERR] - RL [C1723]	Function code data from FL transmitter is malfunctioning. Function code data from FR transmitter is malfunctioning. Function code data from RR transmitter is malfunctioning. Function code data from RL transmitter is malfunctioning.	WT-15
[BATT - VOLT - LOW] - FL [C1724] [BATT - VOLT - LOW] - FR [C1725] [BATT - VOLT - LOW] - RR [C1726] [BATT - VOLT - LOW] - RL [C1727]	Battery voltage of FL transmitter drops. Battery voltage of FR transmitter drops. Battery voltage of RR transmitter drops. Battery voltage of RL transmitter drops.	WT-15
VHCL_SPEED_SIG_ERR [C1729]	Vehicle speed signal is in error.	WT-19
CONTROL MODULE [C1734]	TPMS malfunction in BCM.	WT-20

NOTE:

Before performing the self-diagnosis, be sure to register the ID or else the actual malfunction location may be different from that displayed on CONSULT.

Self-Diagnosis (Without CONSULT)

INFOID:000000008642251

NOTE:

The Signal Tech II Tool (J-50190) can be used to perform the following functions. Refer to the Signal Tech II User Guide for additional information.

- Activate and display TPMS transmitter IDs
- Display tire pressure reported by the TPMS transmitter
- Read TPMS DTCs
- Register TPMS transmitter IDs

SELF DIAGNOSTIC PROCEDURE (WITHOUT CONSULT)

1. Turn ignition switch ON.
2. Ground the tire pressure warning check connector to initiate self diagnosis.
3. Compare the flashing pattern with the flash code chart below.

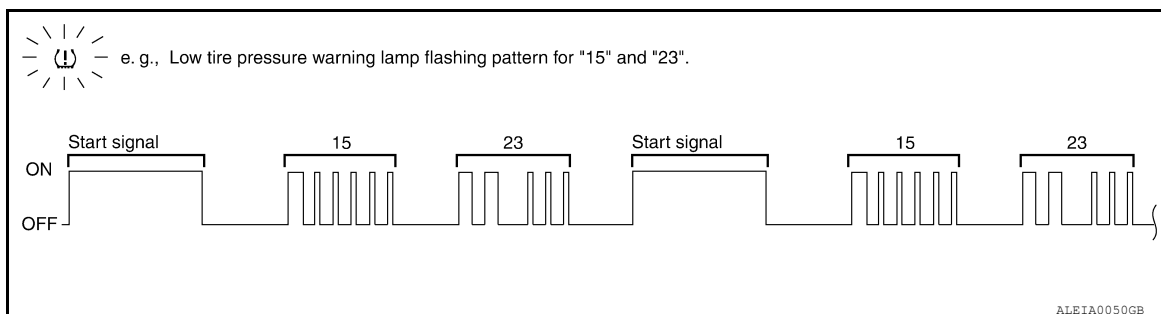

NOTE:

BCM (BODY CONTROL MODULE)

< ECU DIAGNOSIS INFORMATION >

The system is normal when the low tire pressure warning lamp flashes 5 times and continues repeating. Self-diagnosis results are erased automatically by turning the ignition switch OFF.

Flash Code	Malfunction part	Reference page
15 16 17 18	Tire pressure dropped below specified value. Refer to WT-8. "System Description" .	—
21 22 23 24	Transmitter no data (FL) Transmitter no data (FR) Transmitter no data (RR) Transmitter no data (RL)	WT-13
31 32 33 34	Transmitter checksum error (FL) Transmitter checksum error (FR) Transmitter checksum error (RR) Transmitter checksum error (RL)	WT-15
35 36 37 38	Transmitter pressure data error (FL) Transmitter pressure data error (FR) Transmitter pressure data error (RR) Transmitter pressure data error (RL)	WT-17
41 42 43 44	Transmitter function code error (FL) Transmitter function code error (FR) Transmitter function code error (RR) Transmitter function code error (RL)	WT-15
45 46 47 48	Transmitter battery voltage low (FL) Transmitter battery voltage low (FR) Transmitter battery voltage low (RR) Transmitter battery voltage low (RL)	WT-15
52	Vehicle speed signal	WT-19
53	TPMS malfunction in BCM	WT-20

A
B
C
D
WT
F
G
H
I
J
K
L
M
N
O
P

TIRE PRESSURE MONITORING SYSTEM

< WIRING DIAGRAM >

WIRING DIAGRAM

TIRE PRESSURE MONITORING SYSTEM

Wiring Diagram

INFOID:000000008642252

TIRE PRESSURE MONITORING SYSTEM

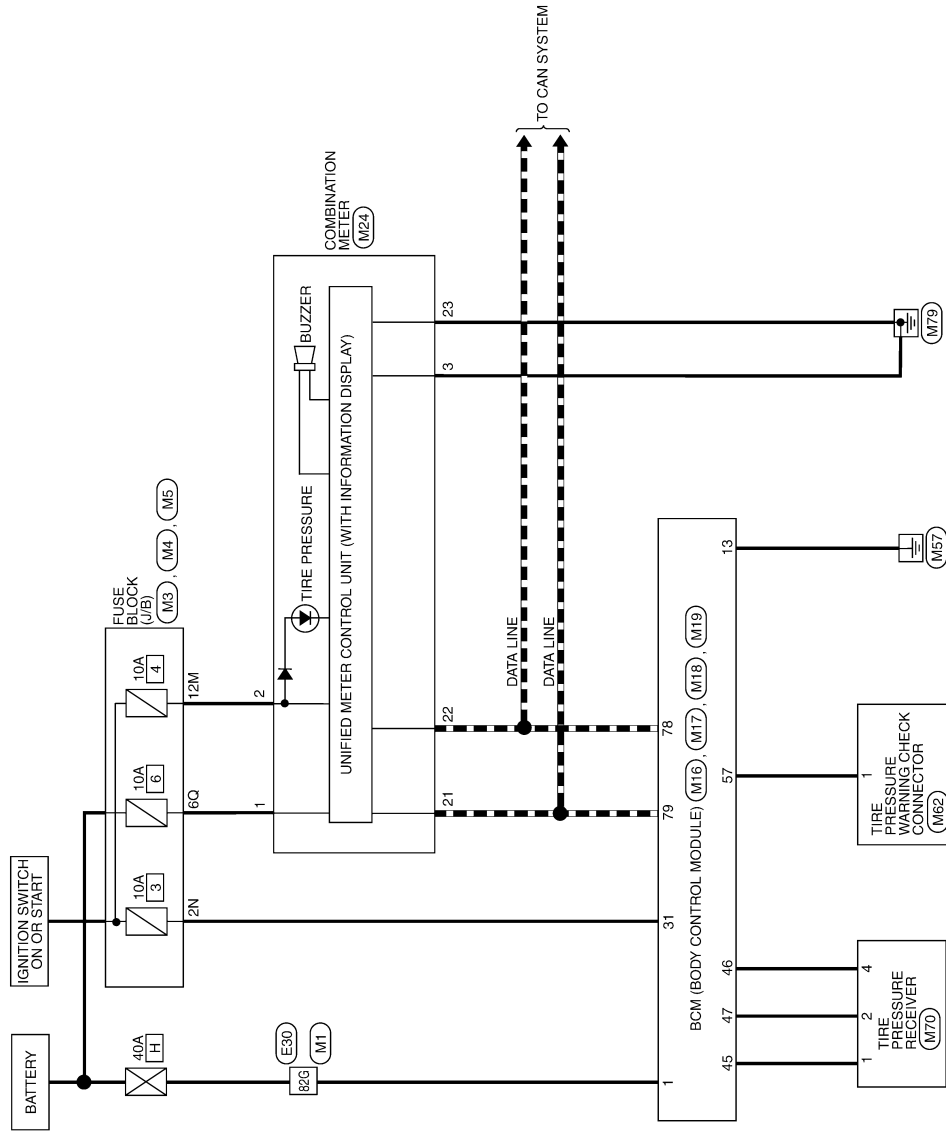

ABEWA0082GB

TIRE PRESSURE MONITORING SYSTEM

< WIRING DIAGRAM >

TIRE PRESSURE MONITORING SYSTEM CONNECTORS

Connector No.	M1
Connector Name	WIRE TO WIRE
Connector Color	WHITE

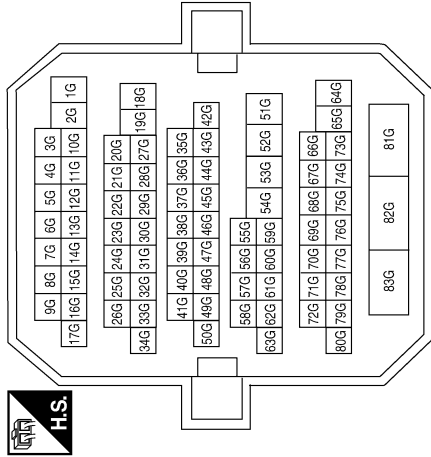

Terminal No.	Color of Wire	Signal Name
82G	W/B	-

Connector No.	M3
Connector Name	FUSE BLOCK (J/B)
Connector Color	WHITE

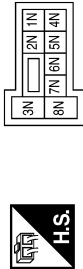

Terminal No.	Color of Wire	Signal Name
2N	G	-

Connector No.	M4
Connector Name	FUSE BLOCK (J/B)
Connector Color	WHITE

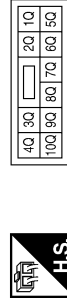

Terminal No.	Color of Wire	Signal Name
6Q	Y/R	-

Connector No.	M5
Connector Name	FUSE BLOCK (J/B)
Connector Color	WHITE

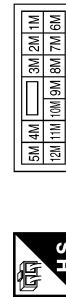

Terminal No.	Color of Wire	Signal Name
12M	O	-

Connector No.	M16
Connector Name	BCM (BODY CONTROL MODULE)
Connector Color	BLACK



Terminal No.	Color of Wire	Signal Name
1	W/B	BATT (F/L)

Connector No.	M17
Connector Name	BCM (BODY CONTROL MODULE)
Connector Color	WHITE

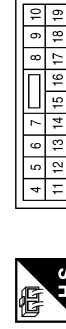

Terminal No.	Color of Wire	Signal Name
13	B	GND1

A
B
C
D
E
F
G
H
I
J
K
L
M
N
O
P

WT

ABEIA0165GB

TIRE PRESSURE MONITORING SYSTEM

< WIRING DIAGRAM >

Connector No.	M18
Connector Name	BCM (BODY CONTROL MODULE)
Connector Color	GREEN



39	36	37	38	35	34	33	32	31	30	29	28	27	26	25	24	23	22	21	20
59	58	57	56	55	54	53	52	51	50	49	48	47	46	45	44	43	42	41	40

Terminal No.	Color of Wire	Signal Name
31	G	IGN F/B
45	P	GND RF2 A/L
46	V/W	A/L POWER SUPPLY 5V
47	G/O	RF2 TUNER SIGNAL
57	W	TPMS MODE

Connector No.	M19
Connector Name	BCM (BODY CONTROL MODULE)
Connector Color	BLACK



79	78	77	76	75	74	73	72	71	70	69	68	67	66	65	64	63	62	61	60
99	98	97	96	95	94	93	92	91	90	89	88	87	86	85	84	83	82	81	80

Terminal No.	Color of Wire	Signal Name
78	P	CAN-L
79	L	CAN-H

Connector No.	M24
Connector Name	COMBINATION METER
Connector Color	WHITE



1	2	3	4	5	6	7	8	9	10	11	12	13	14	15	16	17	18	19	20
21	22	23	24	25	26	27	28	29	30	31	32	33	34	35	36	37	38	39	40

Terminal No.	Color of Wire	Signal Name
1	Y/R	BAT
2	O	IGN
3	B	GND (POWER)
21	L	CAN-H
22	P	CAN-L
23	B	GND (CIRCUIT)

Connector No.	M62
Connector Name	TIRE PRESSURE WARNING CHECK CONNECTOR
Connector Color	WHITE



1	2
---	---

Terminal No.	Color of Wire	Signal Name
1	W	-

Connector No.	M70
Connector Name	TIRE PRESSURE RECEIVER
Connector Color	WHITE



1	2	3	4
---	---	---	---

Terminal No.	Color of Wire	Signal Name
1	P	-
2	G/O	-
4	V/W	-

Connector No.	E30
Connector Name	WIRE TO WIRE
Connector Color	WHITE

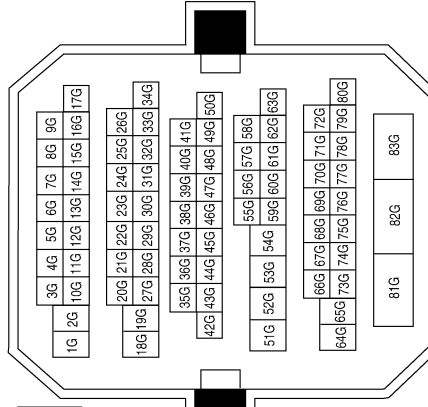

Terminal No.	Color of Wire	Signal Name
82G	LG	-

ABEIA0164GB

TPMS

< SYMPTOM DIAGNOSIS >

SYMPTOM DIAGNOSIS

TPMS

Symptom Table

INFOID:000000008642253

Symptom	Reference
Low tire pressure warning lamp does not come on when ignition switch is turned ON.	WT-50
Low tire pressure warning lamp stays on when ignition switch is turned ON.	WT-51
Low tire pressure warning lamp flashes when ignition switch is turned ON.	WT-52
Hazard warning lamps flash when ignition switch is turned ON.	WT-53
ID registration cannot be completed.	WT-54

A

B

C

D

WT

F

G

H

I

J

K

L

M

N

O

P

LOW TIRE PRESSURE WARNING LAMP DOES NOT TURN ON

< SYMPTOM DIAGNOSIS >

LOW TIRE PRESSURE WARNING LAMP DOES NOT TURN ON

Low Tire Pressure Warning Lamp Does Not Come On When Ignition Switch Is Turned On

INFOID:000000008642254

NOTE:

The Signal Tech II Tool (J-50190) can be used to perform the following functions. Refer to the Signal Tech II User Guide for additional information.

- Activate and display TPMS transmitter IDs
- Display tire pressure reported by the TPMS transmitter
- Read TPMS DTCs
- Register TPMS transmitter IDs

DIAGNOSTIC PROCEDURE

1. SELF-DIAGNOSTIC RESULT CHECK

Using CONSULT, check display contents of BCM in SELF-DIAGNOSIS.

Is "CAN COMM CIRCUIT" displayed in the self-diagnosis display items?

- YES >> Malfunction in CAN communication system. Refer to [LAN-15, "Trouble Diagnosis Flow Chart"](#).
NO >> GO TO 2

2. CHECK COMBINATION METER

Check combination meter operation. Refer to [MWI-29, "CONSULT Function \(METER/M&A\)"](#).

Is the inspection result normal?

- YES >> GO TO 3
NO >> Replace combination meter. Refer to [IP-11, "Removal and Installation"](#).

3. CHECK LOW TIRE PRESSURE WARNING LAMP

Disconnect BCM harness connector.

Does the low tire pressure warning lamp activate?

- YES >> Replace BCM. Refer to [BCS-79, "Removal and Installation"](#).
NO >> Check combination meter operation.

LOW TIRE PRESSURE WARNING LAMP STAYS ON

< SYMPTOM DIAGNOSIS >

LOW TIRE PRESSURE WARNING LAMP STAYS ON

Low Tire Pressure Warning Lamp Stays On When Ignition Switch Is Turned On

INFOID:000000008642255

DIAGNOSTIC PROCEDURE

1. CHECK BCM CONNECTORS

1. Turn ignition switch OFF.
2. Disconnect BCM harness connectors.
3. Check terminals for damage or loose connections.

Is the inspection result normal?

YES >> GO TO 2

NO >> Repair or replace damaged parts.

2. CHECK BCM POWER SUPPLY AND GROUND CIRCUITS

Refer to [BCS-36. "Diagnosis Procedure"](#).

Is the inspection result normal?

YES >> Replace BCM. Refer to [BCS-79. "Removal and Installation"](#).

NO >> Repair BCM circuits.

A
B
C
D
WT
F
G
H
I
J
K
L
M
N
O
P

LOW TIRE PRESSURE WARNING LAMP BLINKS

< SYMPTOM DIAGNOSIS >

LOW TIRE PRESSURE WARNING LAMP BLINKS

Low Tire Pressure Warning Lamp Flashes When Ignition Switch Is Turned On

INFOID:000000008642256

Regarding Wiring Diagram information, refer to [WT-46. "Wiring Diagram"](#).

NOTE:

If low tire pressure warning lamp flashes as shown, the system is normal.

Flash Mode A

- This mode shows transmitter status is OFF-mode.
Carry out transmitter wake up operation. Refer to [WT-5. "Transmitter Wake Up Operation"](#).

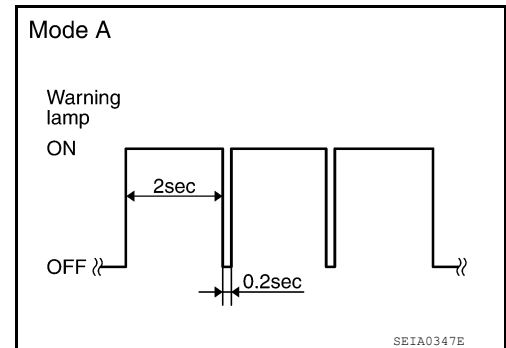

DIAGNOSTIC PROCEDURE

1. CHECK BCM CONNECTORS

1. Turn ignition switch OFF.
2. Disconnect BCM harness connectors.
3. Check terminals for damage or loose connections.

Is the inspection result normal?

- YES >> GO TO 2
NO >> Repair or replace damaged parts.

2. CHECK TIRE PRESSURE WARNING CHECK CONNECTOR CIRCUIT

Check continuity between BCM harness connector M18 terminal 57 and ground.

Continuity should not exist.

Is the inspection result normal?

- YES >> Replace BCM. Refer to [BCS-79. "Removal and Installation"](#).
NO >> Repair circuit for short to ground.

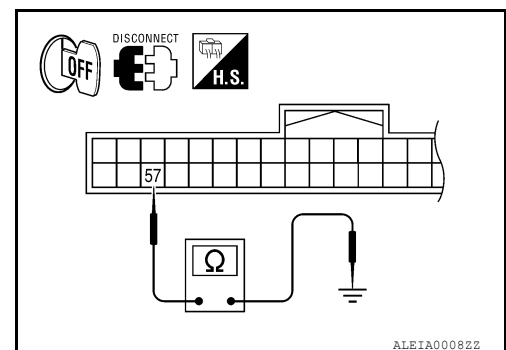

HAZARD WARNING LAMPS FLASH

< SYMPTOM DIAGNOSIS >

HAZARD WARNING LAMPS FLASH

Hazard Warning Lamps Flash When Ignition Switch Is Turned On

INFOID:000000008642257

DIAGNOSTIC PROCEDURE

1. CHECK BCM GROUND CIRCUIT

Check BCM ground circuit. Refer to [BCS-36, "Diagnosis Procedure"](#).

Is the inspection result normal?

YES >> Replace BCM. Refer to [BCS-79, "Removal and Installation"](#).

NO >> Repair BCM ground circuit.

A
B
C
D
E
F
G
H
I
J
K
L
M
N
O
P

WT

ID REGISTRATION CANNOT BE COMPLETED

< SYMPTOM DIAGNOSIS >

ID REGISTRATION CANNOT BE COMPLETED

ID Registration Cannot Be Completed

INFOID:000000008642258

NOTE:

The Signal Tech II Tool (J-50190) can be used to perform the following functions. Refer to the Signal Tech II User Guide for additional information.

- Activate and display TPMS transmitter IDs
- Display tire pressure reported by the TPMS transmitter
- Read TPMS DTCs
- Register TPMS transmitter IDs

DIAGNOSTIC PROCEDURE

1. PERFORM ID REGISTRATION OF ALL TRANSMITTERS

Carry out ID registration of all transmitters. Refer to [WT-6, "ID Registration Procedure"](#).

Can ID registration of all transmitters be completed?

- YES >> Inspection End.
NO >> GO TO [WT-13, "Diagnosis Procedure"](#).

NOISE, VIBRATION AND HARSHNESS (NVH) TROUBLESHOOTING

< SYMPTOM DIAGNOSIS >

NOISE, VIBRATION AND HARSHNESS (NVH) TROUBLESHOOTING

NVH Troubleshooting Chart

INFOID:000000008642259

Use chart below to help you find the cause of the symptom. If necessary, repair or replace these parts.

Symptom		Possible cause and SUSPECTED PARTS										Reference page						
		Improper installation, looseness	Out-of-round	Imbalance	Incorrect tire pressure	Uneven tire wear	Deformation or damage	Non-uniformity	Incorrect tire size	FRONT AXLE AND FRONT SUSPENSION	REAR AXLE AND REAR SUSPENSION	TIRES	ROAD WHEELS	DRIVE SHAFT	BRAKE	STEERING		
Noise	TIRES	x	x	x	x	x	x	x	x	x	x	x	x	x	x	x	WT-58	
		x	x	x	x	x	x	x	x	x	x	x	x	x	x	x	WT-58	
					x				x									WT-58
		x	x	x	x	x	x	x	x	x	x	x	x	x	x	x	x	WT-65
	ROAD WHEEL	x	x	x	x	x	x	x	x	x	x	x	x	x	x	x	x	WT-58
		x	x	x														—
		x	x	x														—
		x	x	x														WT-65
Shake	TIRES	x	x	x	x	x	x	x	x	x	x	x	x	x	x	x	FAX-4, "NVH Troubleshooting Chart", FSU-2, "NVH Troubleshooting Chart"	
		x	x	x	x	x	x	x	x	x	x	x	x	x	x	x	RAX-4, "NVH Troubleshooting Chart", RSU-2, "NVH Troubleshooting Chart"	
																		Refer to TIRES in this chart.
		x	x	x	x	x	x	x	x	x	x	x	x	x	x	x	x	Refer to ROAD WHEEL in this chart.
	ROAD WHEEL	x	x	x														FAX-4, "NVH Troubleshooting Chart"
		x	x	x														BR-6, "NVH Troubleshooting Chart"
		x	x	x														ST-8, "NVH Troubleshooting Chart"
		x	x	x														
Vibration	TIRES	x	x	x	x	x	x	x	x	x	x	x	x	x	x	x		
		x	x	x	x	x	x	x	x	x	x	x	x	x	x	x		
		x	x	x	x	x	x	x	x	x	x	x	x	x	x	x	x	
	ROAD WHEEL	x	x	x														
		x	x	x														
		x	x	x														
		x	x	x														
Shimmy	TIRES	x	x	x	x	x	x	x	x	x	x	x	x	x	x	x		
		x	x	x	x	x	x	x	x	x	x	x	x	x	x	x		
		x	x	x	x	x	x	x	x	x	x	x	x	x	x	x	x	
	ROAD WHEEL	x	x	x														
		x	x	x														
		x	x	x														
		x	x	x														
Shudder	TIRES	x	x	x	x	x	x	x	x	x	x	x	x	x	x	x		
		x	x	x	x	x	x	x	x	x	x	x	x	x	x	x		
		x	x	x	x	x	x	x	x	x	x	x	x	x	x	x	x	
	ROAD WHEEL	x	x	x														
		x	x	x														
		x	x	x														
		x	x	x														
Poor quality ride or handling	TIRES	x	x	x	x	x	x	x	x	x	x	x	x	x	x	x		
		x	x	x	x	x	x	x	x	x	x	x	x	x	x	x		
		x	x	x	x	x	x	x	x	x	x	x	x	x	x	x	x	
	ROAD WHEEL	x	x	x														
		x	x	x														
		x	x	x														
		x	x	x														

x: Applicable

A
B
C
D
E
F
G
H
I
J
K
L
M
N
O
P

WT

PRECAUTIONS

< PRECAUTION >

PRECAUTION

PRECAUTIONS

Precaution for Supplemental Restraint System (SRS) "AIR BAG" and "SEAT BELT PRE-TENSIONER"

INFOID:000000008642260

The Supplemental Restraint System such as "AIR BAG" and "SEAT BELT PRE-TENSIONER", used along with a front seat belt, helps to reduce the risk or severity of injury to the driver and front passenger for certain types of collision. This system includes seat belt switch inputs and dual stage front air bag modules. The SRS system uses the seat belt switches to determine the front air bag deployment, and may only deploy one front air bag, depending on the severity of a collision and whether the front occupants are belted or unbelted. Information necessary to service the system safely is included in the SR and SB section of this Service Manual.

WARNING:

- **To avoid rendering the SRS inoperative, which could increase the risk of personal injury or death in the event of a collision which would result in air bag inflation, all maintenance must be performed by an authorized NISSAN/INFINITI dealer.**
- **Improper maintenance, including incorrect removal and installation of the SRS, can lead to personal injury caused by unintentional activation of the system. For removal of Spiral Cable and Air Bag Module, see the SR section.**
- **Do not use electrical test equipment on any circuit related to the SRS unless instructed to in this Service Manual. SRS wiring harnesses can be identified by yellow and/or orange harnesses or harness connectors.**

PRECAUTIONS WHEN USING POWER TOOLS (AIR OR ELECTRIC) AND HAMMERS

WARNING:

- **When working near the Airbag Diagnosis Sensor Unit or other Airbag System sensors with the Ignition ON or engine running, DO NOT use air or electric power tools or strike near the sensor(s) with a hammer. Heavy vibration could activate the sensor(s) and deploy the air bag(s), possibly causing serious injury.**
- **When using air or electric power tools or hammers, always switch the Ignition OFF, disconnect the battery, and wait at least 3 minutes before performing any service.**

Precaution for Road Wheel

INFOID:000000008642261

- Genuine NISSAN aluminum wheel is designed for each type of vehicle. Use it on the specified vehicle only.
- Use Genuine NISSAN parts for the wheel nuts.
- Always adjusting the wheel balance prior to using them. For the balance weights, use Genuine NISSAN aluminum wheel weights.
- Use caution when handling the aluminum wheels, because they can be easily scratched. When removing dirt, do not use any abrasives, a wire brush, or other items that may scratch the coating. Use a neutral detergent if a detergent is needed.
- After driving on roads scattered with anti-icing salts, wash off the wheels completely.
- When installing road wheels onto the vehicle, always wipe off any dirt or foreign substances to prevent them from being trapped between the contact surfaces of wheel.
- Never apply oil to nut and bolt threads.

PREPARATION

< PREPARATION >

PREPARATION

PREPARATION

Special Service Tool

INFOID:000000008642262

The actual shapes of Kent-Moore tools may differ from those of special service tools illustrated here.

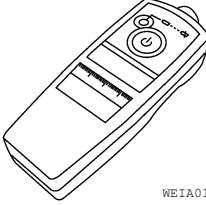
Tool number (Kent-Moore No.) Tool name	Description
KV991B1000 (J-45295) Transmitter activation tool  WEIA0144E	<ul style="list-style-type: none">• Transmitter wake up operation• ID registration procedure

Commercial Service Tools

INFOID:000000008642263

Tool name	Description
Power tool  PIIB1407E	Loosening nuts, screws and bolts

ROAD WHEEL

< PERIODIC MAINTENANCE >

PERIODIC MAINTENANCE

ROAD WHEEL

Inspection

INFOID:000000008642264

ALUMINUM WHEEL

1. Check tires for wear and improper inflation.
2. Check wheels for deformation, cracks and other damage. If deformed, remove wheel and check wheel runout.
 - a. Remove tire from aluminum wheel and mount on a tire balance machine. Refer to [WT-62. "Removal and Installation"](#) to remove transmitter.
 - b. Set dial indicator as shown and rotate the wheel to check for runout.
 - Replace wheel if runout exceeds specification.

Wheel runout Refer to [WT-65](#).

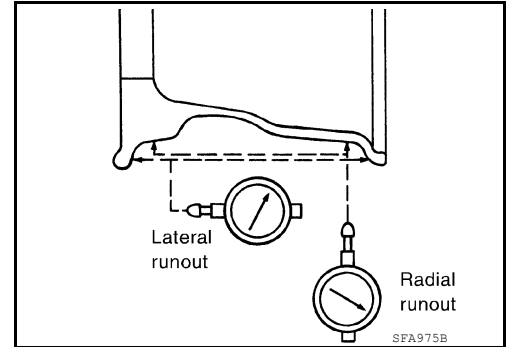

TIRE PRESSURE RECEIVER

< REMOVAL AND INSTALLATION >

REMOVAL AND INSTALLATION

TIRE PRESSURE RECEIVER

Removal and Installation

INFOID:000000008642265

REMOVAL

1. Remove instrument lower cover LH. Refer to [IP-10. "Exploded View"](#).
2. Locate tire pressure receiver (1) to the right of the steering column and disconnect tire pressure receiver electrical connector.
3. Remove tire pressure receiver (1) from bracket using a suitable tool to release the bracket.

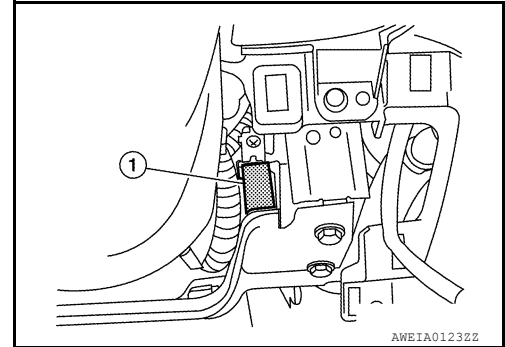

INSTALLATION

Installation is in the reverse order of removal.

A
B
C
D
WT
F
G
H
I
J
K
L
M
N
O
P

ROAD WHEEL TIRE ASSEMBLY

< REMOVAL AND INSTALLATION >

ROAD WHEEL TIRE ASSEMBLY

Adjustment

INFOID:000000008642266

BALANCING WHEELS (ADHESIVE WEIGHT TYPE)

Preparation Before Adjustment

Remove inner and outer balance weights from the road wheel using releasing agent, remove double-faced adhesive tape from the road wheel.

CAUTION:

- **Be careful not to scratch the road wheel during removal.**
- **After removing double-faced adhesive tape, wipe clean all traces of releasing agent from the road wheel.**

Wheel Balance Adjustment

- If a balancer machine has an adhesive weight mode setting, select the adhesive weight mode setting and skip Step 2. below. If a balancer machine only has the clip-on (rim flange) weight mode setting, follow Step 2. to calculate the correct size adhesive weight.

1. Set road wheel on balancer machine using the center hole as a guide. Start the balancer machine.
2. For balancer machines that only have a clip-on (rim flange) weight mode setting, follow this step to calculate the correct size adhesive weight to use. When inner and outer imbalance values are shown on the balancer machine indicator, multiply outer imbalance value by 5/3 (1.67) to determine balance weight that should be used. Select the outer balance weight with a value closest to the calculated value above and install in to the designated outer position of, or at the designated angle in relation to the road wheel.

- a. Indicated imbalance value $\times 5/3 =$ balance weight to be installed

Calculation example:

$23 \text{ g (0.81 oz)} \times 5/3 (1.67) = 38.33 \text{ g (1.35 oz)} \Rightarrow 40 \text{ g (1.41 oz)}$
balance weight (closer to calculated balance weight value)

NOTE:

Note that balance weight value must be closer to the calculated balance weight value.

Example:

$37.4 \Rightarrow 35 \text{ g (1.23 oz)}$

$37.5 \Rightarrow 40 \text{ g (1.41 oz)}$

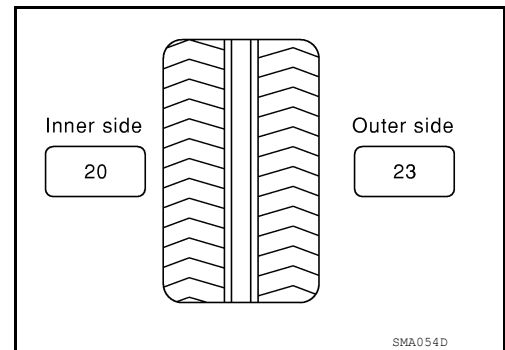

3. Install balance weight in the position shown.

CAUTION:

- **Do not install the inner balance weight before installing the outer balance weight.**
- **Before installing the balance weight, be sure to clean the mating surface of the road wheel.**
- When installing balance weight (1) to road wheel, set it into the grooved area (A) on the inner wall of the road wheel as shown so that the balance weight center (B) is aligned with the balancer machine indication position (angle) (C).

CAUTION:

- **Always use genuine NISSAN adhesive balance weights.**
- **Balance weights are non-reusable; always replace with new ones.**
- **Do not install more than three sheets of balance weight.**

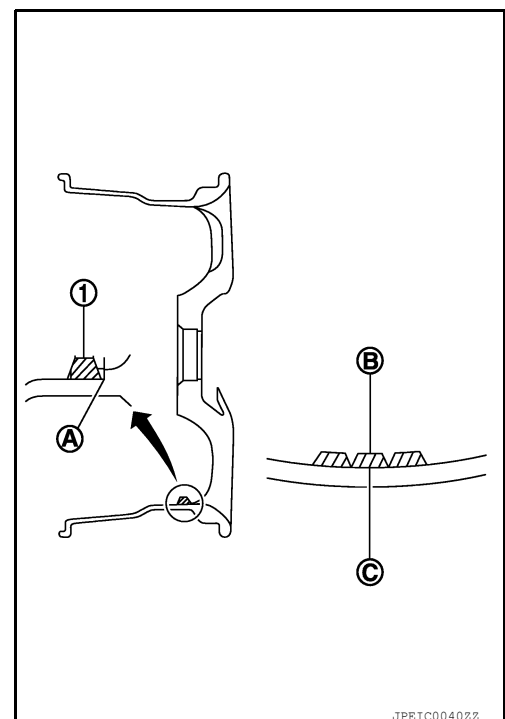

ROAD WHEEL TIRE ASSEMBLY

< REMOVAL AND INSTALLATION >

- If calculated balance weight value exceeds 50 g (1.76 oz), install two balance weight sheets in line with each other as shown.

CAUTION:

Do not install one balance weight sheet on top another.

- Start balancer machine again.
- Install balance weight on inner side of road wheel in the balancer machine indication position (angle).

CAUTION:

Do not install more than two balance weights.

- Start balancer machine. Make sure that inner and outer residual imbalance values are 5 g (0.17 oz) each or below.
- If either residual imbalance value exceeds 5 g (0.17 oz), repeat installation procedures.

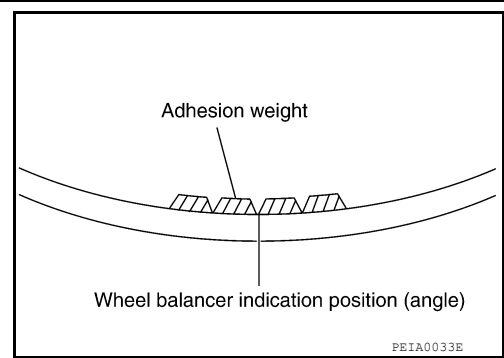

Wheel balance	Dynamic (At flange)	Static (At flange)
Maximum allowable imbalance	Refer to WT-65, "Road Wheel" .	

TIRE ROTATION

- Use power tool to remove wheel and tire assembly.
- Follow the maintenance schedule for tire rotation service intervals. Refer to [MA-5, "FOR USA AND CANADA : Explanation of General Maintenance"](#) (United States and Canada), [MA-7, "FOR MEXICO : Explanation of General Maintenance"](#) (Mexico).

CAUTION:

- Do not include the T-type spare tire when rotating the tires.
- When installing wheels, tighten them diagonally by dividing the work two to three times in order to prevent the wheels from developing any distortion.
- Be careful not to tighten wheel nut at torque exceeding the criteria for preventing strain of disc rotor.

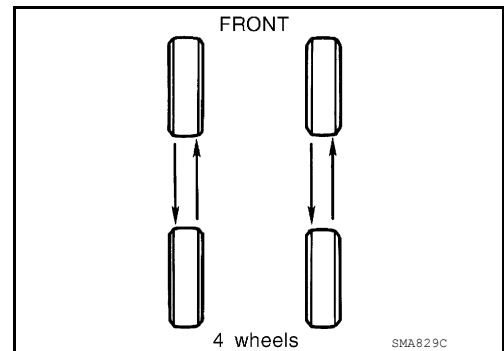

Wheel nut tightening torque : Refer to [WT-65, "Road Wheel"](#).

TRANSMITTER

< UNIT REMOVAL AND INSTALLATION >

UNIT REMOVAL AND INSTALLATION

TRANSMITTER

Exploded View

INFOID:000000008833641

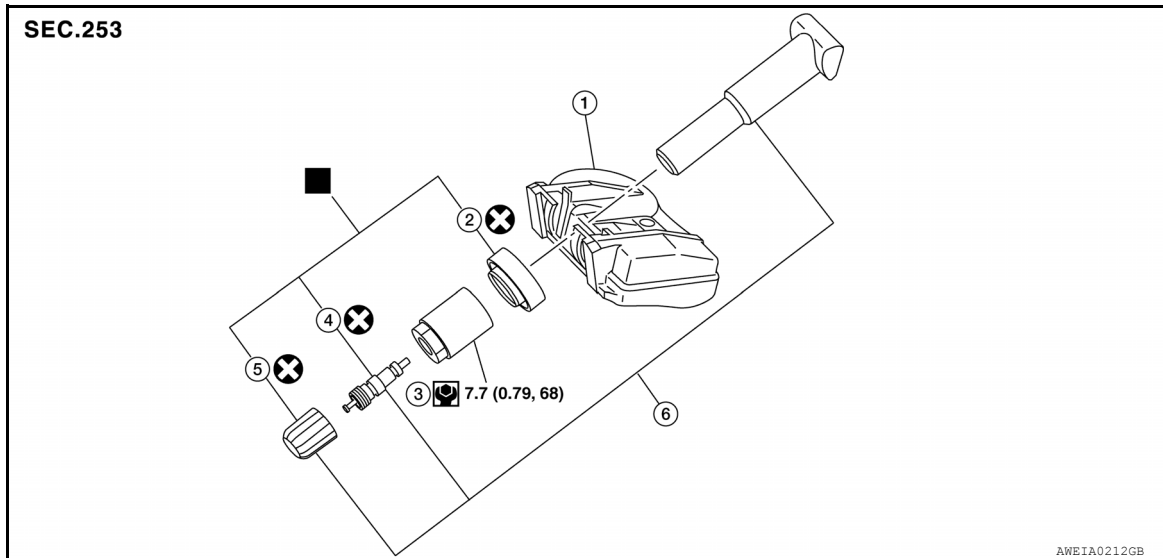

- | | | |
|---------------------------------------|--------------|------------------------|
| 1. Transmitter (tire pressure sensor) | 2. O-ring | 3. Valve stem nut |
| 4. Valve core | 5. Valve cap | 6. Valve stem assembly |
- : Parts that are replaced as a set when the tire is replaced.

Removal and Installation

INFOID:000000008642267

REMOVAL

1. Remove road wheel and tire assembly using power tool.
2. Remove valve cap and valve core to deflate the tire.

NOTE:

If the tire is to be reused, apply a matching mark on the tire in line with the position of the road wheel valve stem assembly for the purpose of road wheel and tire balance adjustment after installation.

3. Remove the valve stem nut and allow transmitter to fall into tire.

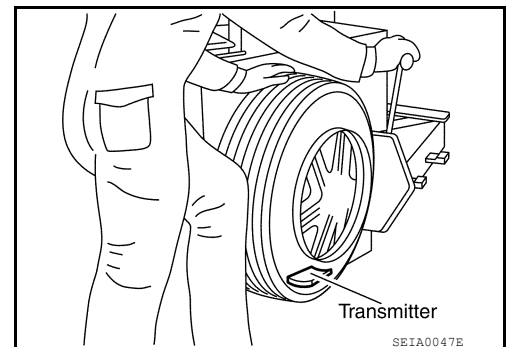

4. Lubricate the tire outside bead well with a suitable non-silicone lubricant, and remove outside of tire from the road wheel. Reach inside the tire and remove the transmitter.

CAUTION:

- Do not use silicone lubricant. Use of silicone lubricant will deteriorate the tire and road wheel.
- Be sure not to damage the road wheel or transmitter.
- Do not allow lubricant to make contact with transmitter.

5. Lubricate the tire inside bead well with a suitable non-silicone lubricant, and remove inside of tire from the road wheel.

TRANSMITTER

< UNIT REMOVAL AND INSTALLATION >

CAUTION:

- Do not use silicone lubricant. Use of silicone lubricant will deteriorate the tire and road wheel.
- Be sure not to damage the road wheel.

6. Remove the valve stem from the transmitter as shown.

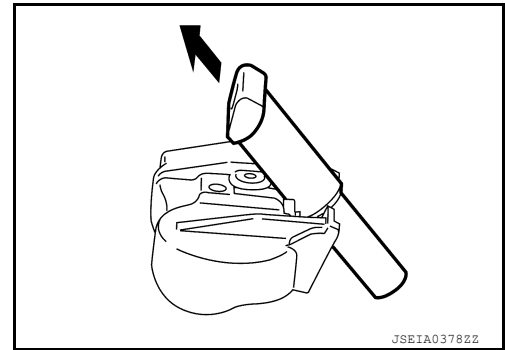

INSTALLATION

1. Apply a suitable non-silicone lubricant to the tire inside bead.

CAUTION:

- Do not use silicone lubricant. Use of silicone lubricant will deteriorate the tire and wheel.

2. Install the tire inside bead (1) onto the road wheel (2) in the position shown.

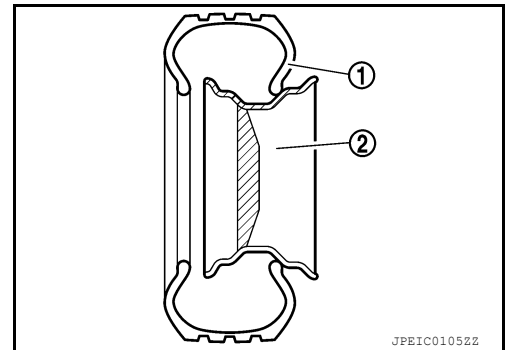

3. Install the valve stem to the transmitter.

4. Install the O-ring to the transmitter.

CAUTION:

- Do not reuse O-ring
- Insert O-ring to the base of the transmitter.
- The base of the valve stem (A) must be positioned in the groove of the metal plate as shown.

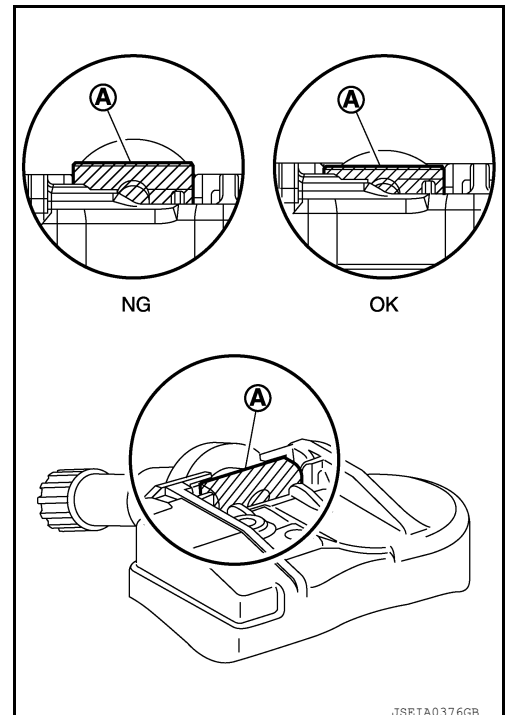

TRANSMITTER

< UNIT REMOVAL AND INSTALLATION >

5. Install transmitter (1) to road wheel while pressing at position (A).

CAUTION:

- Check that O-ring contacts horizontally with road wheel.
- Check that the base of the valve stem is positioned in the groove of the metal plate.

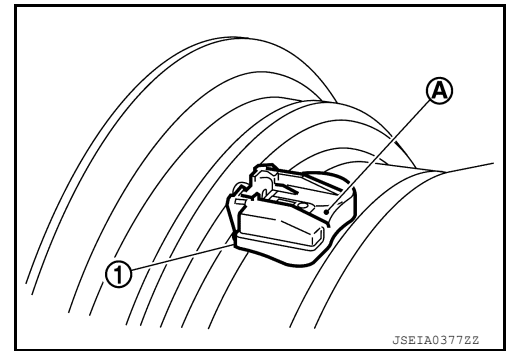

6. Install and tighten the valve stem nut to the specified torque.

Valve stem nut tightening torque : 7.7 N·m (0.79 kg-m, 68 in-lb)

CAUTION:

Do not use power tool for installation.

7. Place wheel on turntable of tire machine. Ensure that transmitter is 270 degrees from mounting/dismounting head.

NOTE:

Do not touch transmitter with mounting head.

8. Apply a suitable non-silicone lubricant to the tire outside bead.

CAUTION:

- Do not use silicone lubricant. Use of silicone lubricant will deteriorate the tire and wheel.
- Do not allow lubricant to make contact with transmitter.

9. Install the tire outside bead onto the road wheel as normal.

NOTE:

If the tire is being reused, align the matching mark applied on the tire with the position of the road wheel valve stem assembly for the purpose of road wheel and tire balance adjustment after installation. Ensure that the tire does not rotate relative to road wheel.

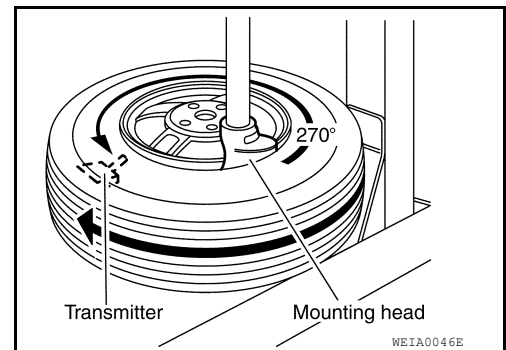

10. Install the valve core and inflate tire.

CAUTION:

Do not reuse valve core.

11. Install the valve cap.

CAUTION:

Do not reuse valve cap.

12. Balance the road wheel and tire assembly. Refer to [WT-60, "Adjustment"](#).

13. Install wheel and tire assembly in appropriate wheel position on vehicle. Refer to [WT-60, "Adjustment"](#).

NOTE:

If replacing the transmitter, then transmitter wake up operation must be performed. Refer to [WT-5, "Transmitter Wake Up Operation"](#).

14. Adjust neutral position of steering angle sensor. Refer to [BRC-6, "ADJUSTMENT OF STEERING ANGLE SENSOR NEUTRAL POSITION : Special Repair Requirement"](#).

SERVICE DATA AND SPECIFICATIONS (SDS)

< SERVICE DATA AND SPECIFICATIONS (SDS)

SERVICE DATA AND SPECIFICATIONS (SDS)

SERVICE DATA AND SPECIFICATIONS (SDS)

Road Wheel

INFOID:0000000008642268

Description		Specification
Wheel type		Aluminum
Wheel runout	Lateral deflection	Less than 0.3 mm (0.012 in)
	Radial deflection	
Allowable imbalance	Dynamic (At rim flange)	Less than 5 g (0.18 oz) (one side)
	Static (At rim flange)	Less than 10 g (0.35 oz)
Wheel nut tightening torque		113 N·m (12 kg-m, 83 ft-lb)
Transmitter Nut		7.7 N·m (0.79 kg-m, 68 in-lb)

Tire

INFOID:0000000008642269

Unit: kPa (kg/cm², psi)

Tire size	Air pressure	
	Conventional tire	Spare tire
P245/45R18	230 (2.3, 33)	—
P245/40R19	230 (2.3, 33)	—
T145/80D17	—	420 (4.2, 60)