

A
B
C
D
E

SECTION **EXT** EXTERIOR

CONTENTS

PRECAUTION	2	Removal and Installation	17	F
PRECAUTIONS	2	FRONT GRILLE	19	
Precaution for Supplemental Restraint System (SRS) "AIR BAG" and "SEAT BELT PRE-TENSIONER"	2	Removal and Installation	19	G
Precaution for Procedure without Cowl Top Cover.....	2	COWL TOP	20	
Precaution for Work	2	Exploded View	20	
PREPARATION	4	Removal and Installation	21	H
PREPARATION	4	FENDER PROTECTOR	23	
Special Service Tools	4	Exploded View	23	I
Commercial Service Tool	4	Removal and Installation	24	
CLIP LIST	5	MUDGUARD	25	
Descriptions for Clips	5	Exploded View	25	J
PERIODIC MAINTENANCE	9	Removal and Installation	25	
SQUEAK AND RATTLE TROUBLE DIAGNOSES	9	DOOR OUTSIDE MOLDING	26	
Work Flow	9	Exploded View	26	EXT
Generic Squeak and Rattle Troubleshooting	10	Removal and Installation	26	
Diagnostic Worksheet	13	ROOF SIDE MOLDING	29	L
REMOVAL AND INSTALLATION	15	Exploded View	29	
FRONT BUMPER	15	Removal and Installation	29	M
Exploded View	15	Clip Replacement	29	
Removal and Installation	16	LICENSE LAMP FINISHER	31	
REAR BUMPER	17	Exploded View	31	N
Exploded View	17	Removal and Installation	31	
		REAR SPOILER	32	
		Exploded View	32	O
		Removal and Installation	32	P

PRECAUTIONS

< PRECAUTION >

PRECAUTION

PRECAUTIONS

Precaution for Supplemental Restraint System (SRS) "AIR BAG" and "SEAT BELT PRE-TENSIONER"

INFOID:000000009465798

The Supplemental Restraint System such as "AIR BAG" and "SEAT BELT PRE-TENSIONER", used along with a front seat belt, helps to reduce the risk or severity of injury to the driver and front passenger for certain types of collision. This system includes seat belt switch inputs and dual stage front air bag modules. The SRS system uses the seat belt switches to determine the front air bag deployment, and may only deploy one front air bag, depending on the severity of a collision and whether the front occupants are belted or unbelted. Information necessary to service the system safely is included in the SR and SB section of this Service Manual.

WARNING:

- To avoid rendering the SRS inoperative, which could increase the risk of personal injury or death in the event of a collision which would result in air bag inflation, all maintenance must be performed by an authorized NISSAN/INFINITI dealer.
- Improper maintenance, including incorrect removal and installation of the SRS, can lead to personal injury caused by unintentional activation of the system. For removal of Spiral Cable and Air Bag Module, see the SR section.
- Do not use electrical test equipment on any circuit related to the SRS unless instructed to in this Service Manual. SRS wiring harnesses can be identified by yellow and/or orange harnesses or harness connectors.

PRECAUTIONS WHEN USING POWER TOOLS (AIR OR ELECTRIC) AND HAMMERS

WARNING:

- When working near the Airbag Diagnosis Sensor Unit or other Airbag System sensors with the Ignition ON or engine running, DO NOT use air or electric power tools or strike near the sensor(s) with a hammer. Heavy vibration could activate the sensor(s) and deploy the air bag(s), possibly causing serious injury.
- When using air or electric power tools or hammers, always switch the Ignition OFF, disconnect the battery, and wait at least 3 minutes before performing any service.

Precaution for Procedure without Cowl Top Cover

INFOID:000000009465799

When performing the procedure after removing cowl top cover, cover the lower end of windshield with urethane, etc.

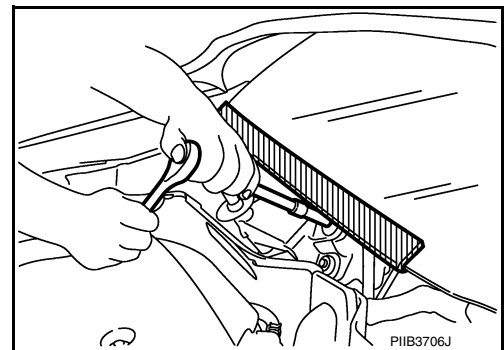

Precaution for Work

INFOID:000000009465800

- When removing or disassembling each component, be careful not to damage or deform it. If a component may be subject to interference, be sure to protect it with a shop cloth.
- When removing (disengaging) components with a screwdriver or similar tool, be sure to wrap the component with a shop cloth or vinyl tape to protect it.
- Protect the removed parts with a shop cloth and prevent them from being dropped.
- Replace a deformed or damaged clip.
- If a part is specified as a non-reusable part, always replace it with a new one.
- Be sure to tighten bolts and nuts securely to the specified torque.
- After installation is complete, be sure to check that each part works properly.
- Follow the steps below to clean components:
 - Water soluble dirt:

PRECAUTIONS

< PRECAUTION >

- Dip a soft cloth into lukewarm water, wring the water out of the cloth and wipe the dirty area.
- Then rub with a soft, dry cloth.
- Oily dirt:
 - Dip a soft cloth into lukewarm water with mild detergent (concentration: within 2 to 3%) and wipe the dirty area.
 - Then dip a cloth into fresh water, wring the water out of the cloth and wipe the detergent off.
 - Then rub with a soft, dry cloth.
- Do not use organic solvent such as thinner, benzene, alcohol or gasoline.
- For genuine leather seats, use a genuine leather seat cleaner.

A

B

C

D

E

F

G

H

I

J

EXT

L

M

N

O

P

PREPARATION

< PREPARATION >

PREPARATION

PREPARATION

Special Service Tools

INFOID:000000009895309

The actual shapes of the tools may differ from those illustrated here.

Tool number (TechMate No.) Tool name	Description
— (J-39570) Chassis Ear	Locating the noise
— (J-46534) Trim Tool Set	Removing trim components
— (J-50397) NISSAN Squeak and Rattle Kit	Repairing the cause of noise

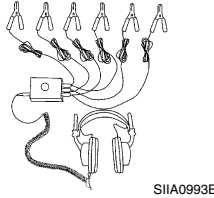

SIIA0993E

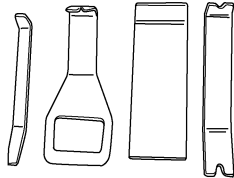

AWJIA0483ZZ



ALJIA1232ZZ

Commercial Service Tool

INFOID:000000009895310

(TechMate No.) Tool name	Description
(J-39565) Engine Ear	Locating the noise

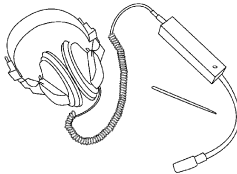

SIIA0995E

CLIP LIST







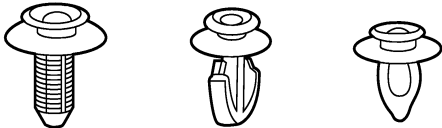

< PREPARATION >

CLIP LIST

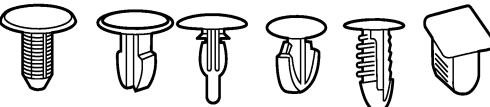
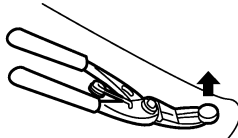
Descriptions for Clips

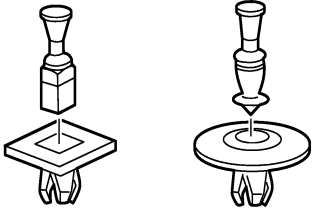
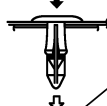
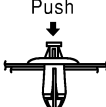
INFOID:000000009465803

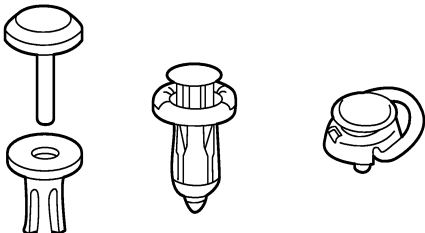
Replace any clips which are damaged during removal or installation.

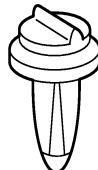
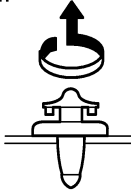





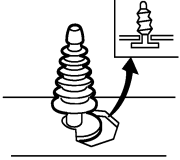
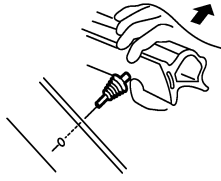

Symbol No.	Shapes	Removal & Installation
C101 		<p>Removal: Remove by bending up with flat-bladed screwdrivers or clip remover.</p> 
C103 		 <p>Removal: Remove with a clip remover.</p>
C203 		<p>Removal: Push center pin to catching position. (Do not remove center pin by hitting it.)</p> <p>Push</p>  <p>Push</p>  <p>Installation:</p>
C205 		<p>Removal:</p> <p>Flat-bladed screwdriver</p>  <p>Clip</p> <p>Finisher</p>
C206 		<p>Removal:</p> 

SIIA0315E

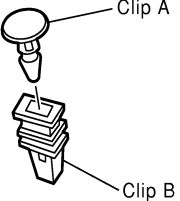
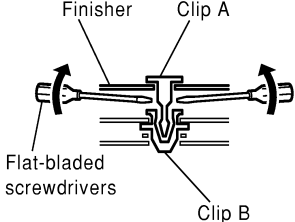
A
B
C
D
E
F
G
H
I
J
EXT
L
M
N
O
P

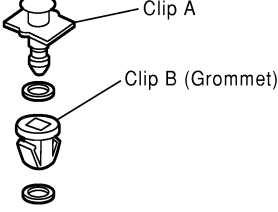
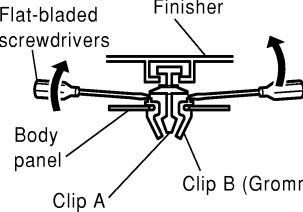
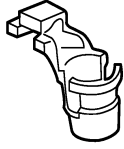
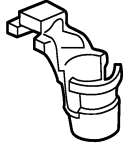
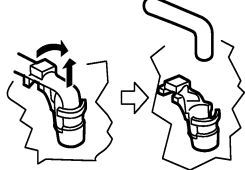
CLIP LIST

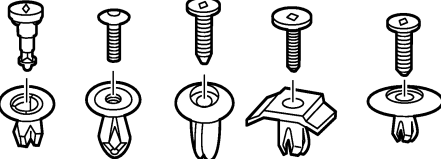







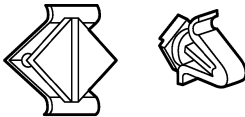

< PREPARATION >

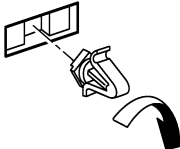
Symbol No.	Shapes	Removal & Installation
<p>CE103</p> 		<p>Removal:</p> 
<p>CF110</p> 		<p>Removal:</p> 
<p>CF118</p> 		<p>Removal:</p> 
<p>CR103</p> 		<p>Removal: Holder portion of clip must be spread out to remove rod.</p> 
<p>CS101</p> 		<p>Removal:</p> <ol style="list-style-type: none"> 1. Screw out with a Phillips screwdriver. 2. Remove female portion with flat-bladed screwdriver. 

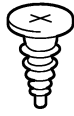
SIIA0316E

CLIP LIST

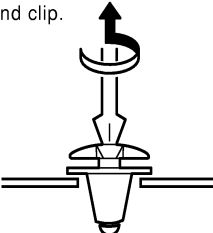
< PREPARATION >

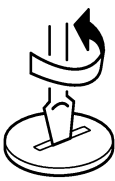



Symbol No.	Shapes	Removal & Installation	
CG101 		Removal:  Rotate 45° to remove	Installation: 
CS102 			
CS113 		Removal: Disconnect upper connection of clip with a flat-bladed screwdriver, then remove clip while inserting a flat-bladed screwdriver between body panel and clip. 	
C111 			

SIIA0317E

A
B
C
D
E
F
G
H
I
J
EXT
L
M
N
O
P

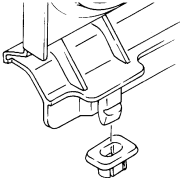
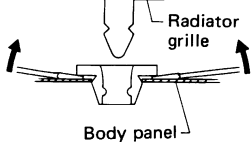
CLIP LIST

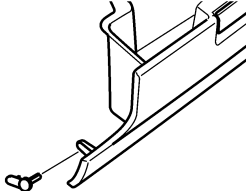
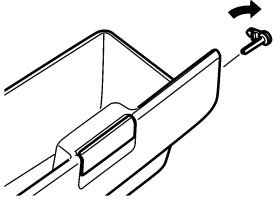
< PREPARATION >

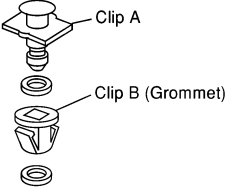
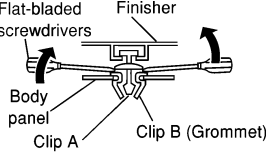
Symbol No.	Shapes	Removal & Installation
<p>CG104</p> 		<p>Removal: Remove by bending up with flat-bladed screwdrivers.</p> 
<p>CE114</p> 		
<p>CF118</p> 		<p>Removal: Flat-bladed screwdrivers Finisher screwdrivers</p> 

ALJIA0564GB

SQUEAK AND RATTLE TROUBLE DIAGNOSES

< PERIODIC MAINTENANCE >

PERIODIC MAINTENANCE

SQUEAK AND RATTLE TROUBLE DIAGNOSES

Work Flow

INFOID:000000009895311

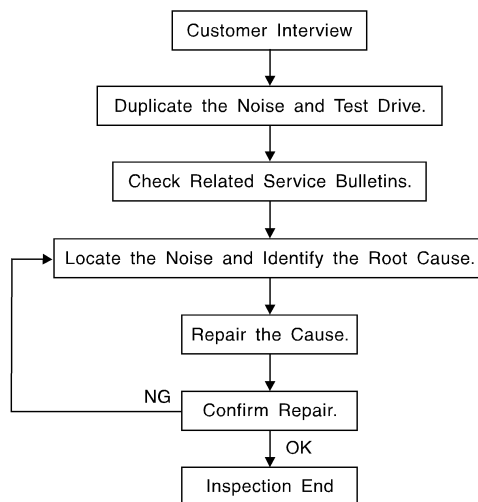

SBT842

CUSTOMER INTERVIEW

Interview the customer if possible, to determine the conditions that exist when the noise occurs. Use the Diagnostic Worksheet during the interview to document the facts and conditions when the noise occurs and any customer's comments; refer to [EXT-13, "Diagnostic Worksheet"](#). This information is necessary to duplicate the conditions that exist when the noise occurs.

- The customer may not be able to provide a detailed description or the location of the noise. Attempt to obtain all the facts and conditions that exist when the noise occurs (or does not occur).
- If there is more than one noise in the vehicle, be sure to diagnose and repair the noise that the customer is concerned about. This can be accomplished by test driving the vehicle with the customer.
- After identifying the type of noise, isolate the noise in terms of its characteristics. The noise characteristics are provided so the customer, service adviser and technician are all speaking the same language when defining the noise.
- Squeak —(Like tennis shoes on a clean floor)
Squeak characteristics include the light contact/fast movement/brought on by road conditions/hard surfaces = higher pitch noise/softer surfaces = lower pitch noises/edge to surface = chirping.
- Creak—(Like walking on an old wooden floor)
Creak characteristics include firm contact/slow movement/twisting with a rotational movement/pitch dependent on materials/often brought on by activity.
- Rattle—(Like shaking a baby rattle)
Rattle characteristics include the fast repeated contact/vibration or similar movement/loose parts/missing clip or fastener/incorrect clearance.
- Knock —(Like a knock on a door)
Knock characteristics include hollow sounding/sometimes repeating/often brought on by driver action.
- Tick—(Like a clock second hand)
Tick characteristics include gentle contacting of light materials/loose components/can be caused by driver action or road conditions.
- Thump—(Heavy, muffled knock noise)
Thump characteristics include softer knock/dead sound often brought on by activity.
- Buzz—(Like a bumble bee)
Buzz characteristics include high frequency rattle/firm contact.
- Often the degree of acceptable noise level will vary depending upon the person. A noise that you may judge as acceptable may be very irritating to the customer.
- Weather conditions, especially humidity and temperature, may have a great effect on noise level.

DUPLICATE THE NOISE AND TEST DRIVE

SQUEAK AND RATTLE TROUBLE DIAGNOSES

< PERIODIC MAINTENANCE >

If possible, drive the vehicle with the customer until the noise is duplicated. Note any additional information on the Diagnostic Worksheet regarding the conditions or location of the noise. This information can be used to duplicate the same conditions when you confirm the repair.

If the noise can be duplicated easily during the test drive, to help identify the source of the noise, try to duplicate the noise with the vehicle stopped by doing one or all of the following:

- 1) Close a door.
 - 2) Tap or push/pull around the area where the noise appears to be coming from.
 - 3) Rev the engine.
 - 4) Use a floor jack to recreate vehicle "twist".
 - 5) At idle, apply engine load (electrical load, half-clutch on M/T model, drive position on CVT and A/T models).
 - 6) Raise the vehicle on a hoist and hit a tire with a rubber hammer.
- Drive the vehicle and attempt to duplicate the conditions the customer states exist when the noise occurs.
 - If it is difficult to duplicate the noise, drive the vehicle slowly on an undulating or rough road to stress the vehicle body.

CHECK RELATED SERVICE BULLETINS

After verifying the customer concern or symptom, check ASIST for Technical Service Bulletins (TSBs) related to that concern or symptom.

If a TSB relates to the symptom, follow the procedure to repair the noise.

LOCATE THE NOISE AND IDENTIFY THE ROOT CAUSE

1. Narrow down the noise to a general area. To help pinpoint the source of the noise, use a listening tool (Chassis Ear: J-39570, Engine Ear: J-39565 and mechanic's stethoscope).
2. Narrow down the noise to a more specific area and identify the cause of the noise by:
 - removing the components in the area that you suspect the noise is coming from.
Do not use too much force when removing clips and fasteners, otherwise clips and fasteners can be broken or lost during the repair, resulting in the creation of new noise.
 - tapping or pushing/pulling the component that you suspect is causing the noise.
Do not tap or push/pull the component with excessive force, otherwise the noise will be eliminated only temporarily.
 - feeling for a vibration with your hand by touching the component(s) that you suspect is (are) causing the noise.
 - placing a piece of paper between components that you suspect are causing the noise.
 - looking for loose components and contact marks.
Refer to [EXT-10. "Generic Squeak and Rattle Troubleshooting"](#).

REPAIR THE CAUSE

- If the cause is a loose component, tighten the component securely.
- If the cause is insufficient clearance between components:
 - separate components by repositioning or loosening and retightening the component, if possible.
 - insulate components with a suitable insulator such as urethane pads, foam blocks, felt cloth tape or urethane tape. A NISSAN Squeak and Rattle Kit (J-50397) is available through your authorized NISSAN Parts Department.

CAUTION:

Do not use excessive force as many components are constructed of plastic and may be damaged.

NOTE:

- Always check with the Parts Department for the latest parts information.
- The materials contained in the NISSAN Squeak and Rattle Kit (J-50397) are listed on the inside cover of the kit; and can each be ordered separately as needed.
- The following materials not found in the kit can also be used to repair squeaks and rattles.
 - SILICONE GREASE: Use instead of UHMW tape that will be visible or does not fit. The silicone grease will only last a few months.
 - SILICONE SPRAY: Use when grease cannot be applied.
 - DUCT TAPE: Use to eliminate movement.

CONFIRM THE REPAIR

Confirm that the cause of a noise is repaired by test driving the vehicle. Operate the vehicle under the same conditions as when the noise originally occurred. Refer to the notes on the Diagnostic Worksheet.

Generic Squeak and Rattle Troubleshooting

INFOID:000000009895312

Refer to Table of Contents for specific component removal and installation information.

SQUEAK AND RATTLE TROUBLE DIAGNOSES

< PERIODIC MAINTENANCE >

INSTRUMENT PANEL

Most incidents are caused by contact and movement between:

1. Cluster lid A and the instrument panel
2. Acrylic lens and combination meter housing
3. Instrument panel to front pillar finisher
4. Instrument panel to windshield
5. Instrument panel pins
6. Wiring harnesses behind the combination meter
7. A/C defroster duct and duct joint

These incidents can usually be located by tapping or moving the components to duplicate the noise or by pressing on the components while driving to stop the noise. Most of these incidents can be repaired by applying felt cloth tape or silicone spray (in hard to reach areas). Urethane pads can be used to insulate wiring harness.

CAUTION:

Do not use silicone spray to isolate a squeak or rattle. If you saturate the area with silicone, you will not be able to recheck the repair.

CENTER CONSOLE

Components to pay attention to include:

1. Shift selector assembly cover to finisher
2. A/C control unit and cluster lid C
3. Wiring harnesses behind audio and A/C control unit

The instrument panel repair and isolation procedures also apply to the center console.

DOORS

Pay attention to the:

1. Finisher and inner panel making a slapping noise
2. Inside handle escutcheon to door finisher
3. Wiring harnesses tapping
4. Door striker out of alignment causing a popping noise on starts and stops

Tapping or moving the components or pressing on them while driving to duplicate the conditions can isolate many of these incidents. You can usually insulate the areas with felt cloth tape or insulator foam blocks from the NISSAN Squeak and Rattle Kit (J-50397) to repair the noise.

TRUNK

Trunk noises are often caused by a loose jack or loose items put into the trunk by the owner.

In addition look for:

1. Trunk lid bumpers out of adjustment
2. Trunk lid striker out of adjustment
3. The trunk lid torsion bars knocking together
4. A loose license plate or bracket

Most of these incidents can be repaired by adjusting, securing or insulating the item(s) or component(s) causing the noise.

SUNROOF/HEADLINING

Noises in the sunroof/headlining area can often be traced to one of the following:

1. Sunroof lid, rail, linkage or seals making a rattle or light knocking noise
2. Sun visor shaft shaking in the holder
3. Front or rear windshield touching headlining and squeaking

Again, pressing on the components to stop the noise while duplicating the conditions can isolate most of these incidents. Repairs usually consist of insulating with felt cloth tape.

OVERHEAD CONSOLE (FRONT AND REAR)

Overhead console noises are often caused by the console panel clips not being engaged correctly. Most of these incidents are repaired by pushing up on the console at the clip locations until the clips engage.

In addition look for:

SQUEAK AND RATTLE TROUBLE DIAGNOSES

< PERIODIC MAINTENANCE >

1. Loose harness or harness connectors.
2. Front console map/reading lamp lens loose.
3. Loose screws at console attachment points.

SEATS

When isolating seat noise it's important to note the position the seat is in and the load placed on the seat when the noise is present. These conditions should be duplicated when verifying and isolating the cause of the noise.

Cause of seat noise include:

1. Headrest rods and holder
2. A squeak between the seat pad cushion and frame
3. The rear seatback lock and bracket

These noises can be isolated by moving or pressing on the suspected components while duplicating the conditions under which the noise occurs. Most of these incidents can be repaired by repositioning the component or applying urethane tape to the contact area.

UNDERHOOD

Some interior noise may be caused by components under the hood or on the engine wall. The noise is then transmitted into the passenger compartment.

Causes of transmitted underhood noise include:

1. Any component installed to the engine wall
2. Components that pass through the engine wall
3. Engine wall mounts and connectors
4. Loose radiator installation pins
5. Hood bumpers out of adjustment
6. Hood striker out of adjustment

These noises can be difficult to isolate since they cannot be reached from the interior of the vehicle. The best method is to secure, move or insulate one component at a time and test drive the vehicle. Also, engine rpm or load can be changed to isolate the noise. Repairs can usually be made by moving, adjusting, securing, or insulating the component causing the noise.

SQUEAK AND RATTLE TROUBLE DIAGNOSES

< PERIODIC MAINTENANCE >

Diagnostic Worksheet

INFOID:000000009895313

Dear Customer:

We are concerned about your satisfaction with your vehicle. Repairing a squeak or rattle sometimes can be very difficult. To help us fix your vehicle right the first time, please take a moment to note the area of the vehicle where the squeak or rattle occurs and under what conditions. You may be asked to take a test drive with a service advisor or technician to ensure we confirm the noise you are hearing.

SQUEAK & RATTLE DIAGNOSTIC WORKSHEET

I. WHERE DOES THE NOISE COME FROM? (circle the area of the vehicle)

The illustrations are for reference only, and may not reflect the actual configuration of your vehicle.

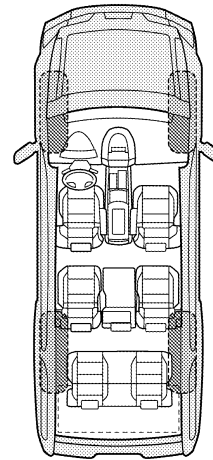
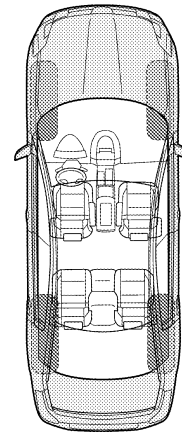
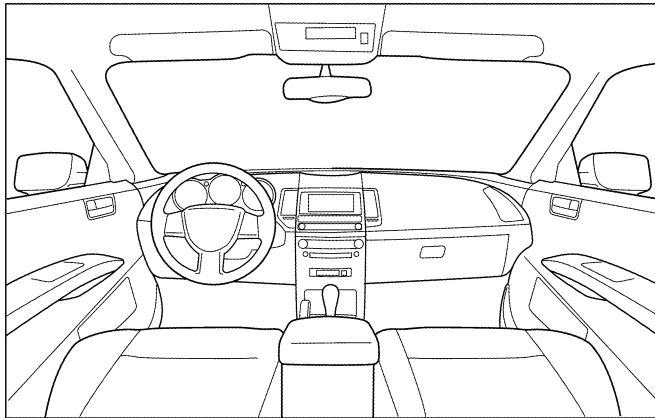

Continue to page 2 of the worksheet and briefly describe the location of the noise or rattle. In addition, please indicate the conditions which are present when the noise occurs.

A
B
C
D
E
F
G
H
I
J
EXT
L
M
N
O
P

SQUEAK AND RATTLE TROUBLE DIAGNOSES

< PERIODIC MAINTENANCE >

SQUEAK & RATTLE DIAGNOSTIC WORKSHEET - page 2

Briefly describe the location where the noise occurs:

II. WHEN DOES IT OCCUR? (please check the boxes that apply)

- | | |
|---|--|
| <input type="checkbox"/> Anytime | <input type="checkbox"/> After sitting out in the rain |
| <input type="checkbox"/> 1st time in the morning | <input type="checkbox"/> When it is raining or wet |
| <input type="checkbox"/> Only when it is cold outside | <input type="checkbox"/> Dry or dusty conditions |
| <input type="checkbox"/> Only when it is hot outside | <input type="checkbox"/> Other: |

III. WHEN DRIVING:

- Through driveways
- Over rough roads
- Over speed bumps
- Only about ____ mph
- On acceleration
- Coming to a stop
- On turns: left, right or either (circle)
- With passengers or cargo
- Other: _____
- After driving ____ miles or ____ minutes

IV. WHAT TYPE OF NOISE

- Squeak (like tennis shoes on a clean floor)
- Creak (like walking on an old wooden floor)
- Rattle (like shaking a baby rattle)
- Knock (like a knock at the door)
- Tick (like a clock second hand)
- Thump (heavy muffled knock noise)
- Buzz (like a bumble bee)

TO BE COMPLETED BY DEALERSHIP PERSONNEL

Test Drive Notes:

	YES	NO	Initials of person performing
Vehicle test driven with customer	<input type="checkbox"/>	<input type="checkbox"/>	_____
- Noise verified on test drive	<input type="checkbox"/>	<input type="checkbox"/>	_____
- Noise source located and repaired	<input type="checkbox"/>	<input type="checkbox"/>	_____
- Follow up test drive performed to confirm repair	<input type="checkbox"/>	<input type="checkbox"/>	_____

VIN: _____ Customer Name _____

W.O.# _____ Date: _____

This form must be attached to Work Order

LAI0071E

FRONT BUMPER

< REMOVAL AND INSTALLATION >

REMOVAL AND INSTALLATION

FRONT BUMPER

Exploded View

INFOID:000000009465807

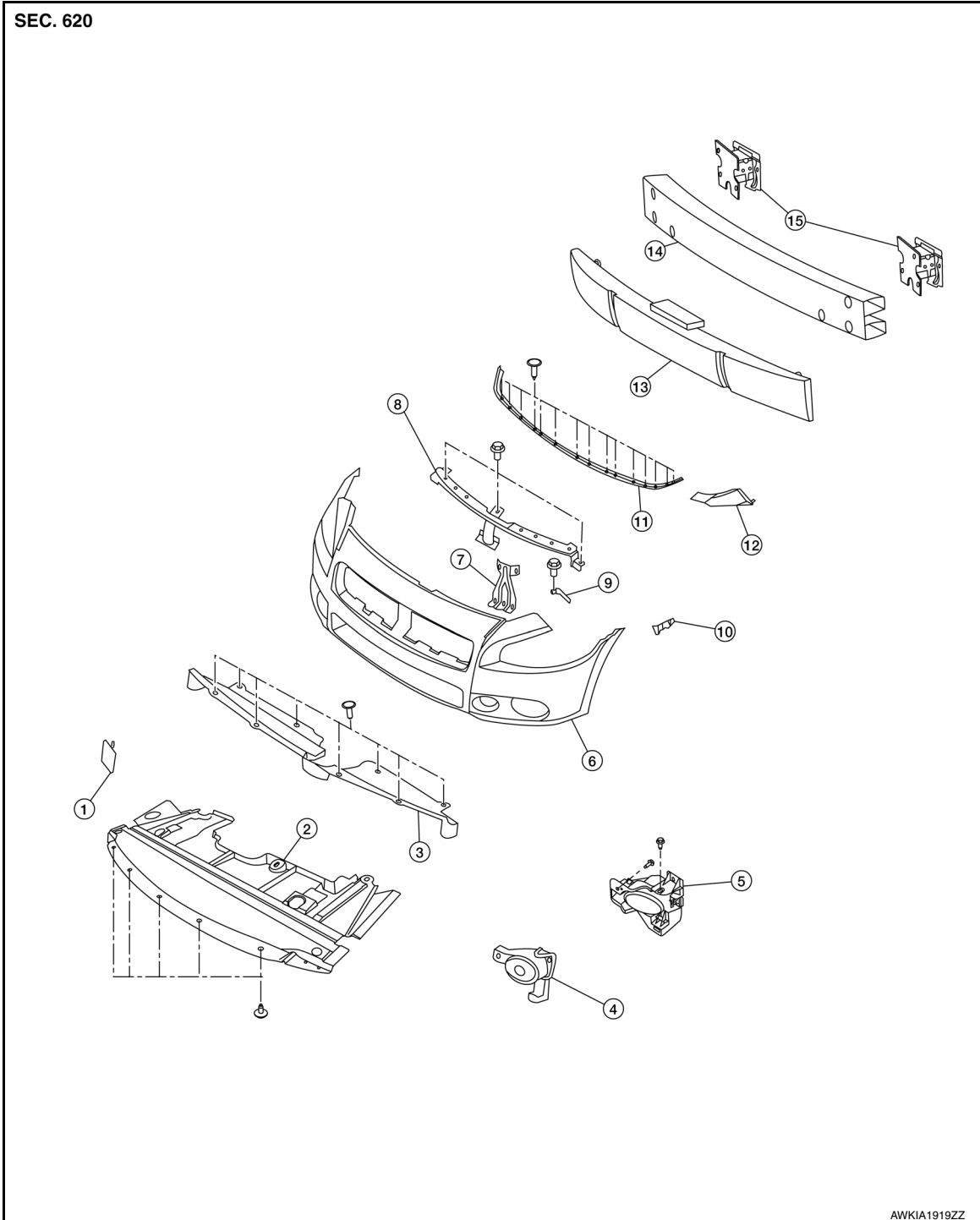

- | | | |
|-------------------------------|--------------------------------|-----------------------------------|
| 1. Tow cover | 2. Engine under cover | 3. Core support cover |
| 4. Fog lamp cover | 5. Fog lamp (if equipped) | 6. Front bumper fascia |
| 7. Center support bracket | 8. Upper fascia support | 9. Front bumper upper bracket |
| 10. Front bumper side bracket | 11. Front bumper fascia seal | 12. Front bumper stiffener |
| 13. Front energy absorber | 14. Front bumper reinforcement | 15. Front bumper supports (RH/LH) |

A
B
C
D
E
F
G
H
I
J
EXT
L
M
N
O
P

FRONT BUMPER

< REMOVAL AND INSTALLATION >

Removal and Installation

INFOID:000000009465808

REMOVAL

1. Release the core support cover clips, then remove the core support cover.
2. Release the engine under cover clips, then remove engine under cover.
3. Remove the front fender protector side covers (RH/LH). Refer to [EXT-24. "Removal and Installation"](#).
4. Remove both front fender protectors clips and screws from the front edge and partially remove, moving the protectors as necessary for access.
5. Remove the front bumper fascia clips and screws, then remove front bumper fascia.
6. Remove the fog lamps (if equipped). Refer to [EXL-156. "Removal and Installation"](#).
7. Remove the front grille. Refer to [EXT-19. "Removal and Installation"](#).
8. Remove the front energy absorber.
9. Disconnect the harness connector, then remove the ambient temperature sensor.
10. Remove the upper fascia support bolts, then remove upper fascia support.
11. Remove the front bumper reinforcement bolts, then remove front bumper reinforcement.
12. Remove the front bumper support bolts, then remove the front bumper supports (RH/LH).

INSTALLATION

Installation is in the reverse order of removal.

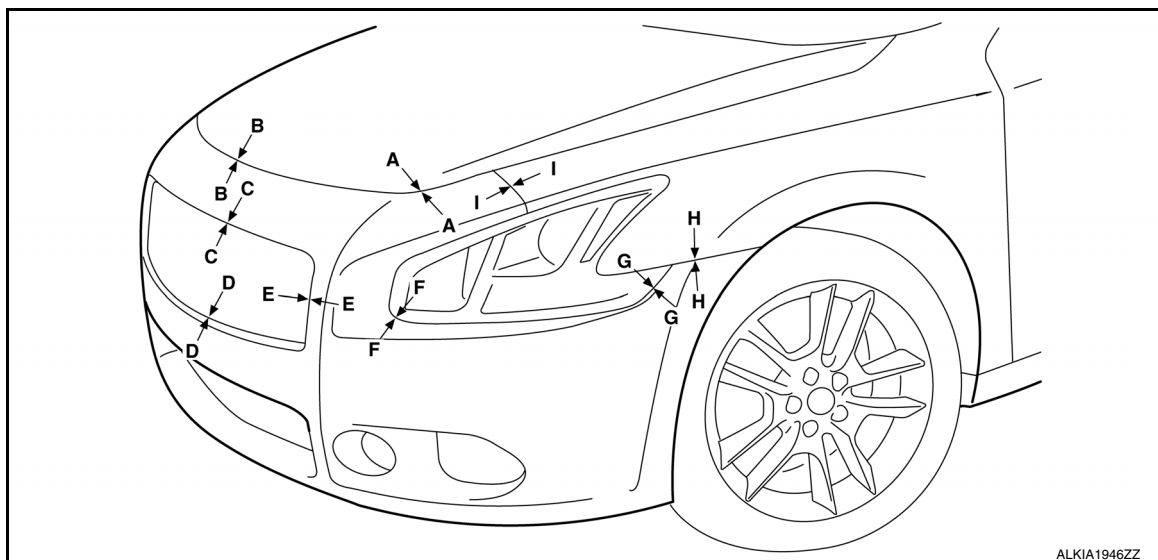

ALKIA1946ZZ

mm (in)

Section	Measurement	Minimum	Target Value	Maximum
A-A	Surface height	-2.23 (-0.088)	-0.63 (-0.025)	0.97 (0.038)
B-B	Clearance	2.1 (0.083)	4.1 (0.161)	6.1 (0.240)
B-B	Surface height	-2.6 (-0.102)	-1.0 (-0.039)	0.6 (0.024)
C-C	Clearance	1.0 (0.039)	2.0 (0.079)	3.0 (0.118)
D-D	Clearance	1.0 (0.039)	2.0 (0.079)	3.0 (0.118)
E-E	Clearance	0.6 (0.024)	2.0 (0.079)	3.4 (0.134)
F-F	Clearance	0.3 (0.012)	1.5 (0.059)	2.7 (0.106)
G-G	Clearance	0.3 (0.012)	1.5 (0.059)	2.7 (0.106)
G-G	Surface height	-1.1 (-0.043)	0.0 (0.000)	1.1 (0.043)
H-H	Clearance	0.0 (0.000)	0.0 (0.000)	0.8 (0.031)
H-H	Surface height	-0.3 (-0.012)	0.7 (0.028)	1.7 (0.067)
I-I	Clearance	0.0 (0.000)	0.0 (0.000)	0.7 (0.028)
I-I	Surface height	-1.0 (-0.039)	0.0 (0.000)	1.0 (0.039)

REAR BUMPER

< REMOVAL AND INSTALLATION >

REAR BUMPER

Exploded View

INFOID:000000009465809

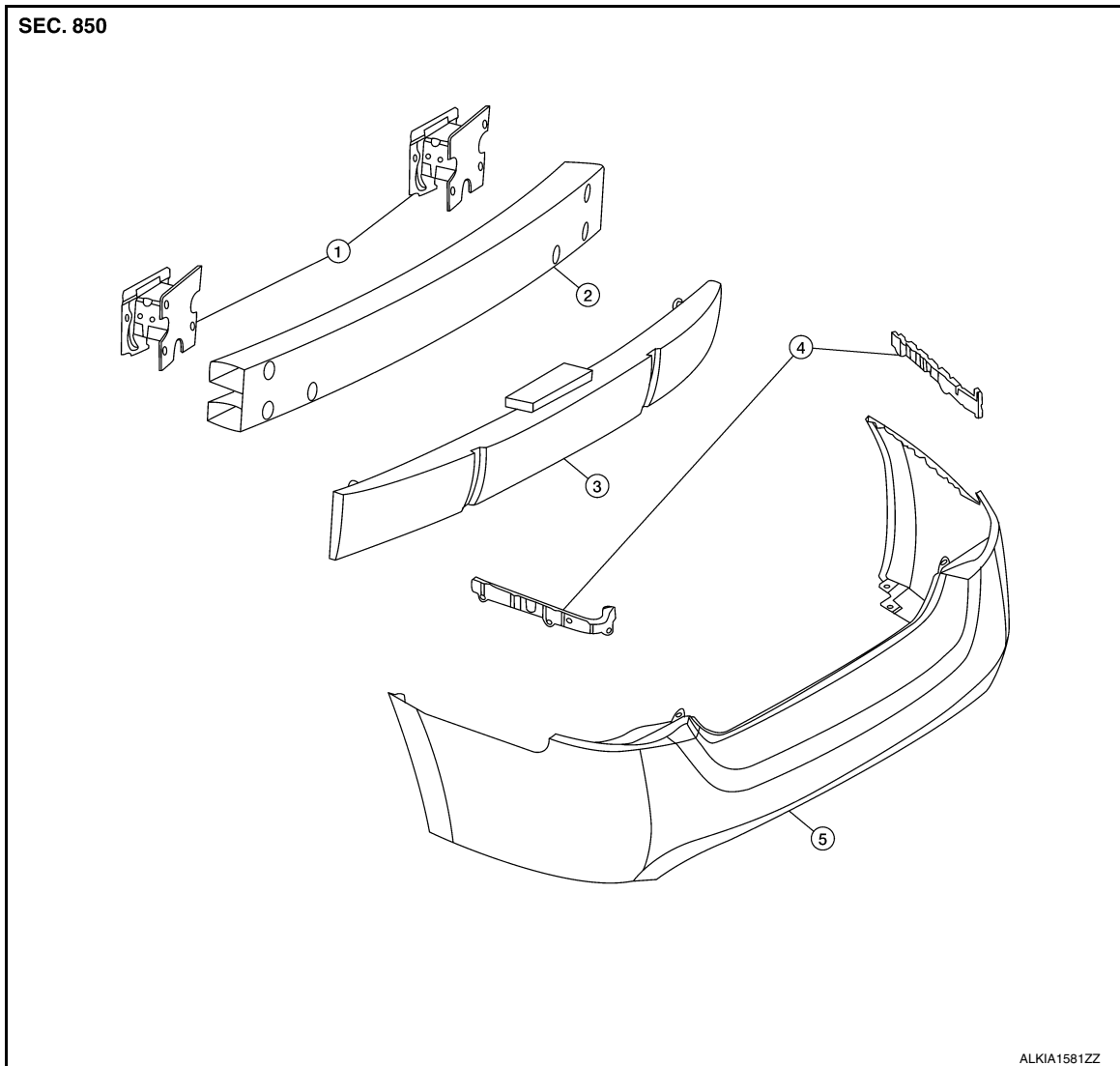

- | | | |
|---------------------------------|------------------------------|-------------------------|
| 1. Rear bumper supports (RH/LH) | 2. Rear bumper reinforcement | 3. Rear energy absorber |
| 4. Side bracket (RH/LH) | 5. Rear bumper fascia | |

Removal and Installation

INFOID:000000009465810

REMOVAL

1. Remove trunk floor carpet, side finishers, and rear finisher. Refer to [EXT-31, "Exploded View"](#).
2. Remove the rear combination lamps (RH/LH). Refer to [EXL-162, "Removal and Installation"](#).
3. Remove rear wheels (RH/LH), then remove rear fender protectors (RH/LH). Refer to [EXT-24, "Removal and Installation"](#).
4. Remove rear bumper fascia clips and screws detach the rear bumper fascia from the side brackets (RH/LH), then remove the rear bumper fascia.
5. Remove the rear energy absorber.
6. Remove the rear bumper reinforcement bolts, then remove rear bumper reinforcement.
7. Remove the rear bumper support bolts, then remove the rear bumper supports (RH/LH).

INSTALLATION

A
B
C
D
E
F
G
H
I
J

EXT

L
M
N
O
P

REAR BUMPER

< REMOVAL AND INSTALLATION >

Installation is in the reverse order of removal.

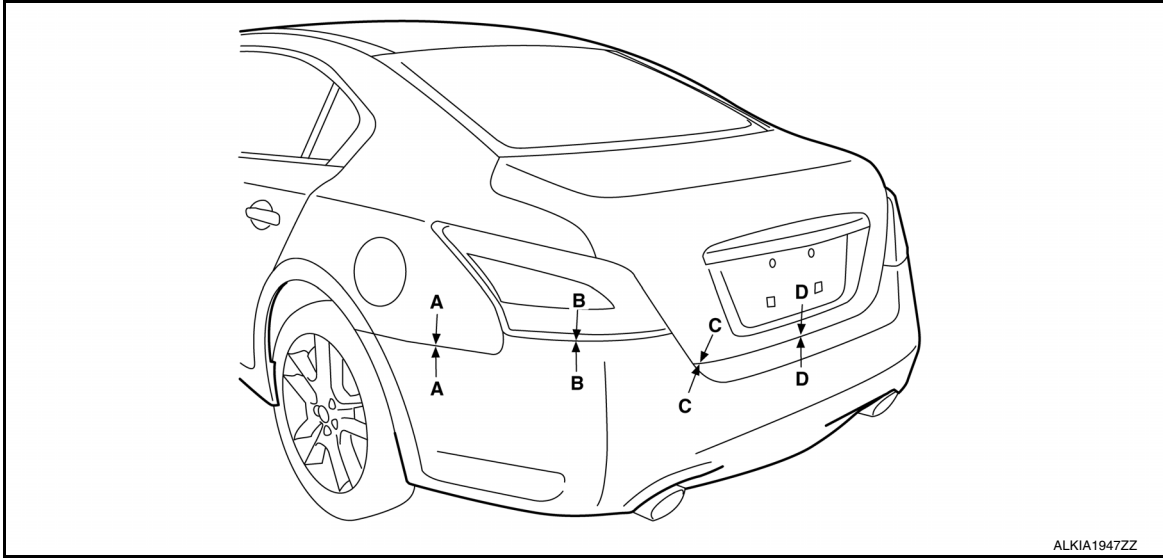

mm (in)

Section	Measurement	Minimum	Target Value	Maximum
A-A	Clearance	0.0 (0.000)	0.0 (0.000)	0.8 (0.031)
A-A	Surface height	-1.8 (-0.071)	-0.8 (-0.031)	0.2 (0.008)
B-B	Clearance	0.5 (0.020)	2.0 (0.079)	3.5 (0.138)
B-B	Surface height	-1.5 (-0.059)	0.0 (0.000)	1.5 (0.059)
C-C	Clearance	3.0 (0.118)	5.0 (0.197)	7.0 (0.276)
D-D	Clearance	5.0 (0.197)	7.0 (0.276)	9.0 (0.354)

FRONT GRILLE

< REMOVAL AND INSTALLATION >

FRONT GRILLE

Removal and Installation

INFOID:000000009465811

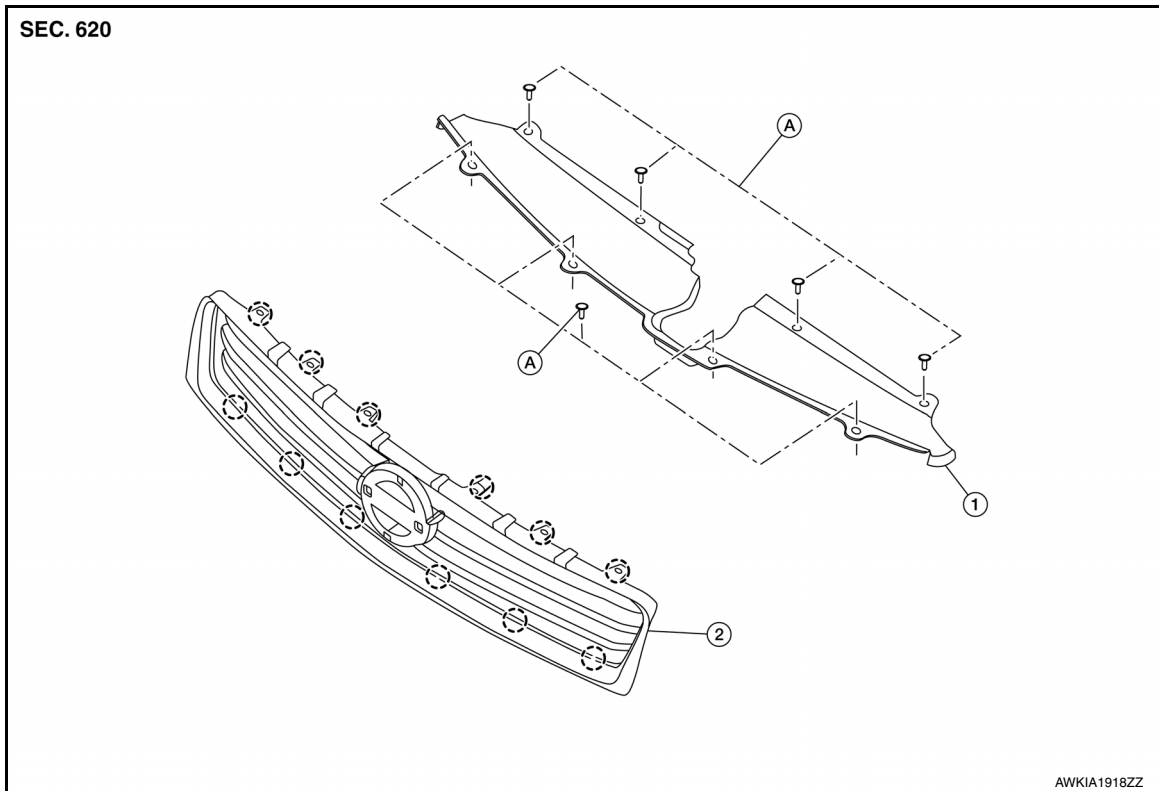

1. Core support cover

2. Front grille

○ Pawl

REMOVAL

1. Remove the core support cover clips, then remove core support cover.
2. Release the front air guide clips, then remove front air guide.
3. Release the front grille pawls from behind and push outward, then remove front grille.

INSTALLATION

Installation is in the reverse order of removal.

A
B
C
D
E
F
G
H
I
J
EXT
L
M
N
O
P

COWL TOP

< REMOVAL AND INSTALLATION >

COWL TOP

Exploded View

INFOID:000000009465812

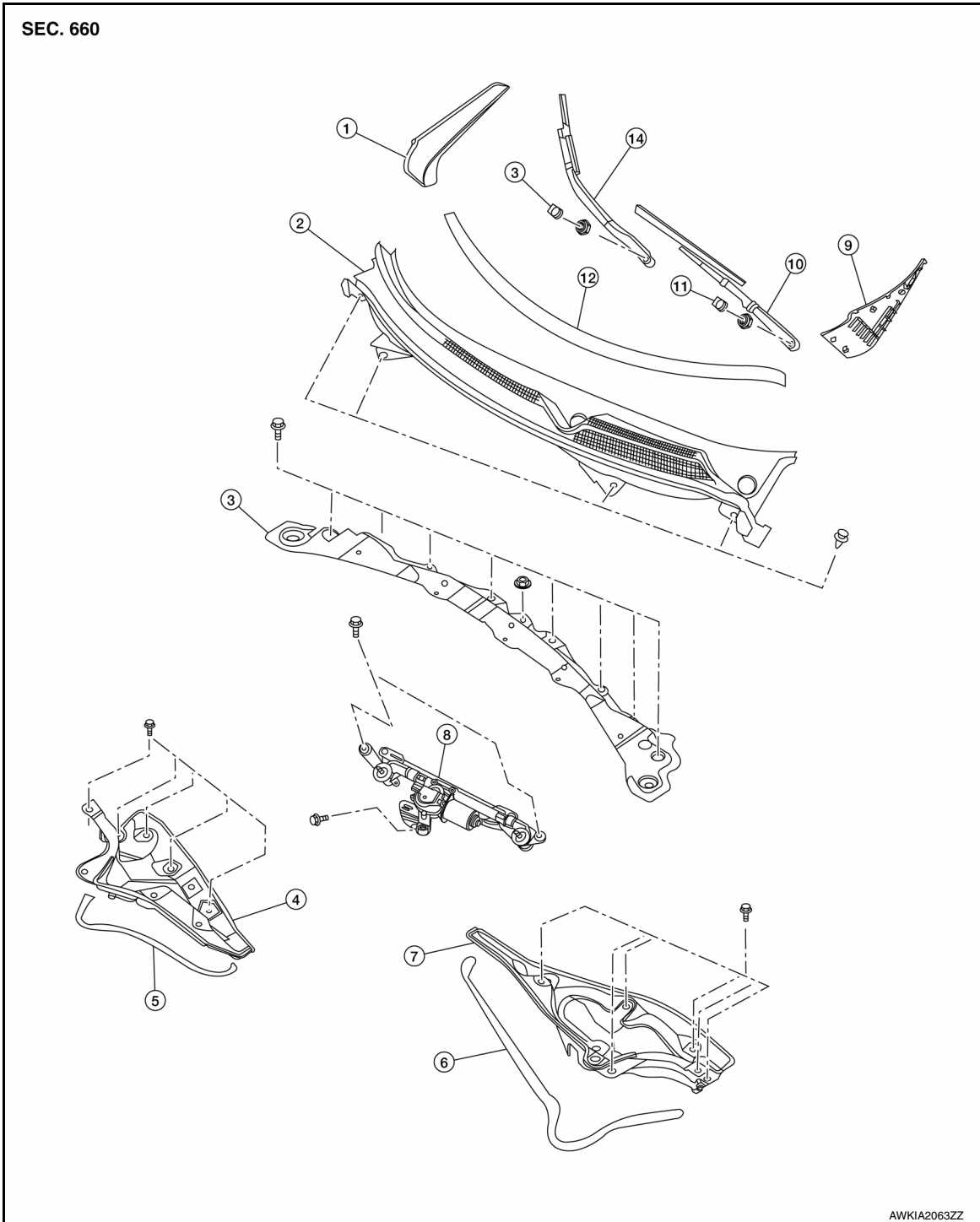

- | | | |
|---------------------------------------|---------------------------------------|---------------------------------------|
| 1. Cowl top side trim cover (RH) | 2. Cowl top grille | 3. Lower cowl top extension brace |
| 4. Lower cowl top extension (RH) | 5. Lower cowl top extension seal (RH) | 6. Lower cowl top extension seal (LH) |
| 7. Lower cowl top extension (LH) | 8. Front wiper drive assembly | 9. Cowl top side trim cover (LH) |
| 10. Wiper arm and blade assembly (LH) | 11. Wiper arm cap (LH) | 12. Cowl top weatherstrip |
| 13. Wiper arm cap (RH) | 14. Wiper arm and blade assembly (RH) | |

COWL TOP

< REMOVAL AND INSTALLATION >

Removal and Installation

INFOID:00000009465813

REMOVAL

1. Remove both wiper arms (RH/LH). Refer to [WW-78. "FRONT WIPER ARMS : Removal and Installation"](#).
2. Remove the cowl top weatherstrip clips, then remove cowl top weatherstrip.
3. Release the pawls, then remove the cowl top side trim covers (RH/LH).

⊖: Pawl

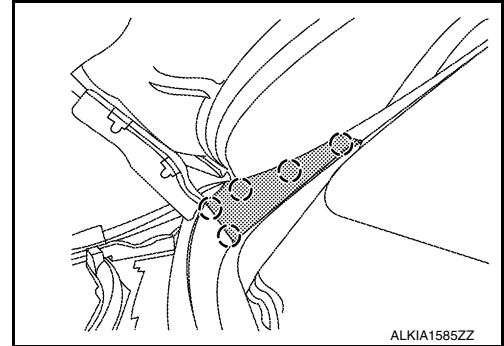

4. Pinch the cowl top extension clips (A) to release, then remove.
⇐: Front
5. Disconnect the washer nozzle supply hose.
6. Release the cowl top grille clips, then remove cowl top.
7. Disconnect the harness connector from the wiper motor. Refer to [WW-78. "FRONT WIPER DRIVE ASSEMBLY : Removal and Installation"](#).
8. Remove the lower cowl top extension brace bolts, then remove the lower cowl extension brace.
9. Remove the front wiper drive assembly. Refer to [WW-78. "FRONT WIPER DRIVE ASSEMBLY : Removal and Installation"](#).
10. Remove the lower cowl top extension RH/LH bolts, then remove lower cowl top extensions (RH/LH).

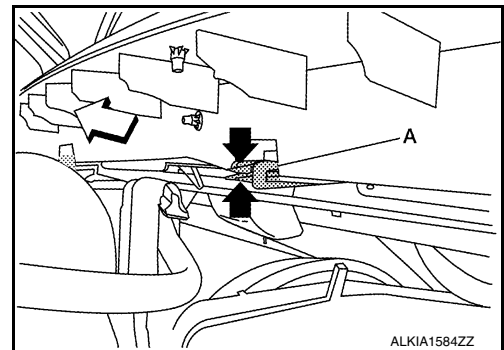

INSTALLATION

Installation is in the reverse order of removal.

CAUTION:

After installing, perform adjustment of wiper arm. Refer to [WW-78. "FRONT WIPER ARMS : Removal and Installation"](#).

- When installing the lower cowl top extension RH, tighten the bolts in the order shown.

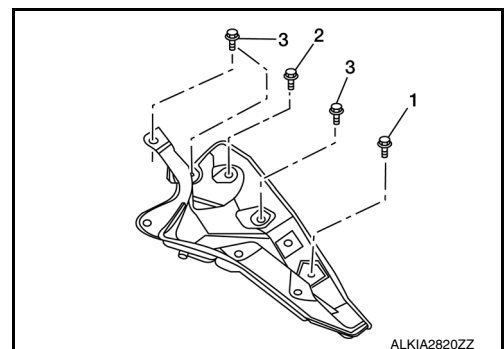

A
B
C
D
E
F
G
H
I
J
EXT
L
M
N
O
P

COWL TOP

< REMOVAL AND INSTALLATION >

- When installing the lower cowl top extension LH, tighten the bolts in the order shown.

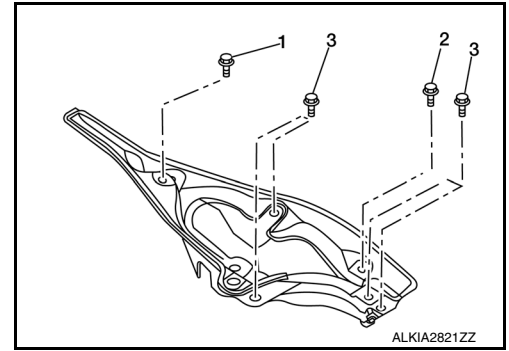

- When installing the lower cowl top extension brace, tighten the bolts in the order shown.

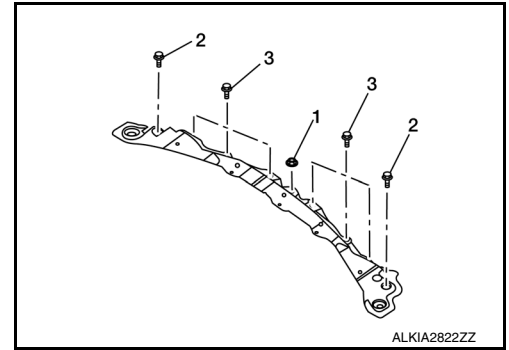

FENDER PROTECTOR

< REMOVAL AND INSTALLATION >

FENDER PROTECTOR

Exploded View

INFOID:00000009465814

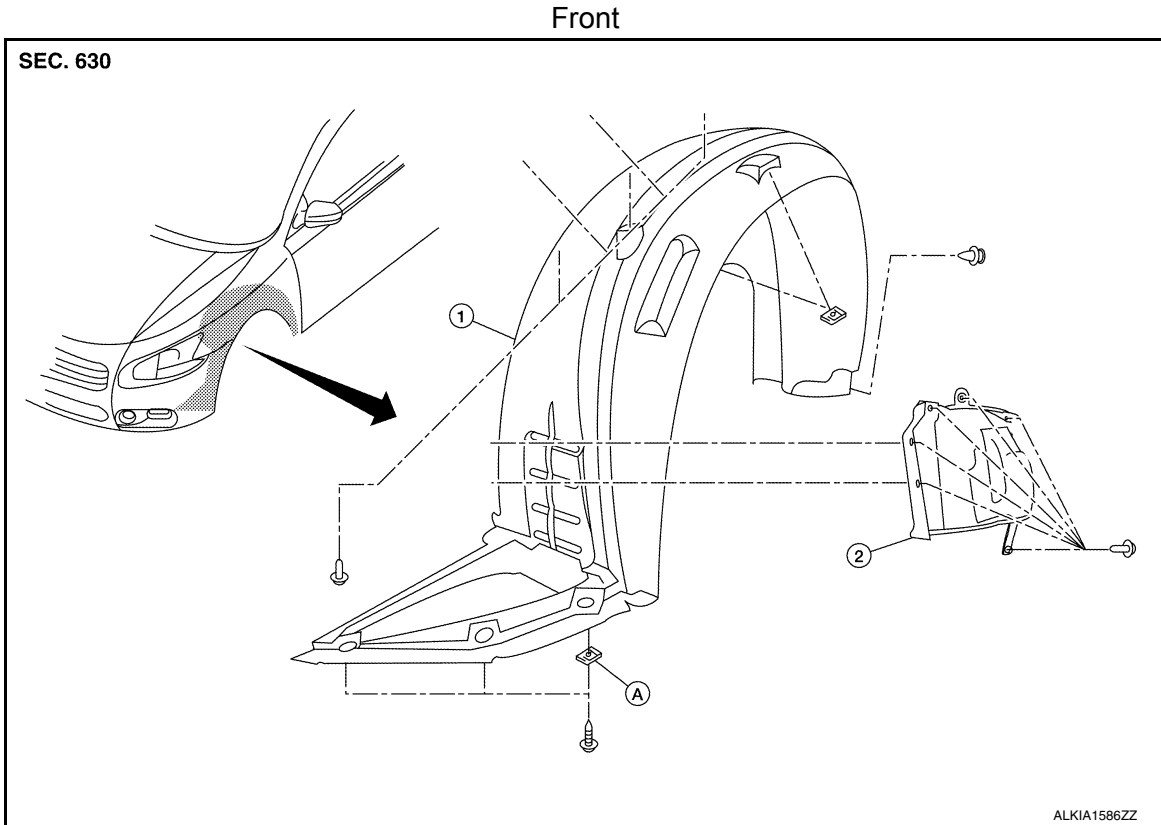

1. Front fender protector 2. Front fender protector side cover A. J-clip

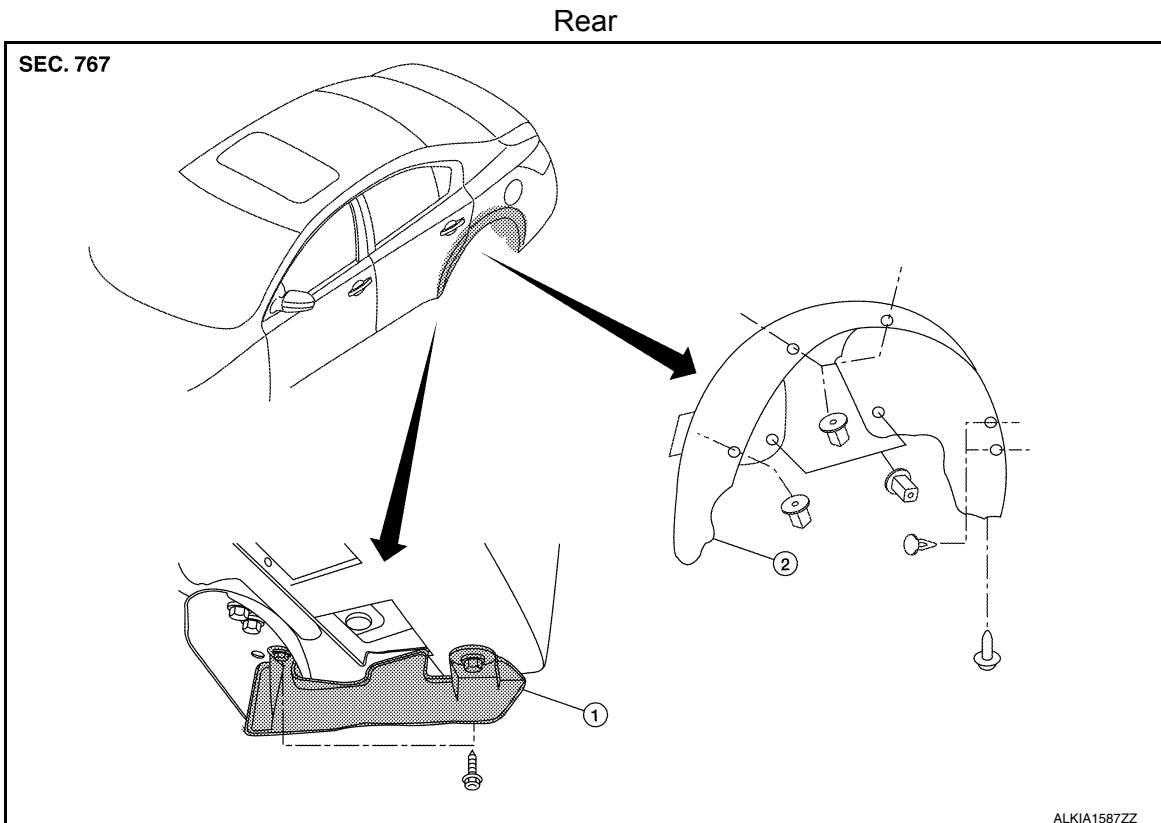

A
B
C
D
E
F
G
H
I
J
EXT
L
M
N
O
P

FENDER PROTECTOR

< REMOVAL AND INSTALLATION >

1. Rear wind deflector

2. Rear fender protector

Removal and Installation

INFOID:000000009465815

FRONT FENDER PROTECTOR

Removal

NOTE:

Position front tires as necessary to remove the front fender protectors.

1. Remove the front screw from center mudguard.
2. Remove the front fender protector side cover clips, then remove front fender protector side cover.
3. Remove the front fender protector screws and clips, then remove front fender protector.

Installation

Installation is in the reverse order of removal.

NOTE:

Position front tires as necessary to install the front fender protectors.

REAR FENDER PROTECTOR

Removal

1. Remove the rear tire/wheel assembly. Refer to [WT-60, "Adjustment"](#).
2. Remove the rear fender protector screws and clips.
3. Remove the fender protector.
4. Remove the wind deflector screws, then remove the wind deflector.

Installation

Installation is in the reverse order of removal.

MUDGUARD

< REMOVAL AND INSTALLATION >

MUDGUARD

Exploded View

INFOID:000000009465816

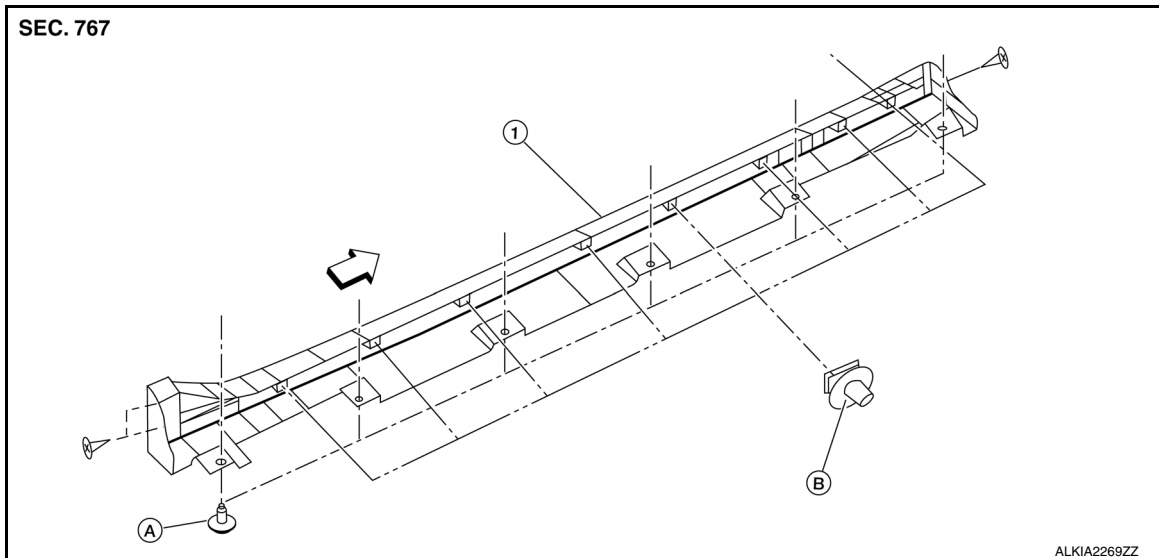

1. Mudguard

A. Clip C205

B. Clip CF118

⇐ Front

Removal and Installation

INFOID:000000009465817

REMOVAL

1. Remove the clips located on the underbody.
2. Remove the center mudguard front and rear screws.
3. Remove the rear wind deflector bolt. Refer to [EXT-24. "Removal and Installation"](#).
4. Release the clips located behind the center mudguard using a suitable tool, beginning with the front working rearward.
5. Remove the center mudguard from body side.

INSTALLATION

Installation is in the reverse order of removal.

DOOR OUTSIDE MOLDING

< REMOVAL AND INSTALLATION >

DOOR OUTSIDE MOLDING

Exploded View

INFOID:000000009465818

SEC. 800 • 820

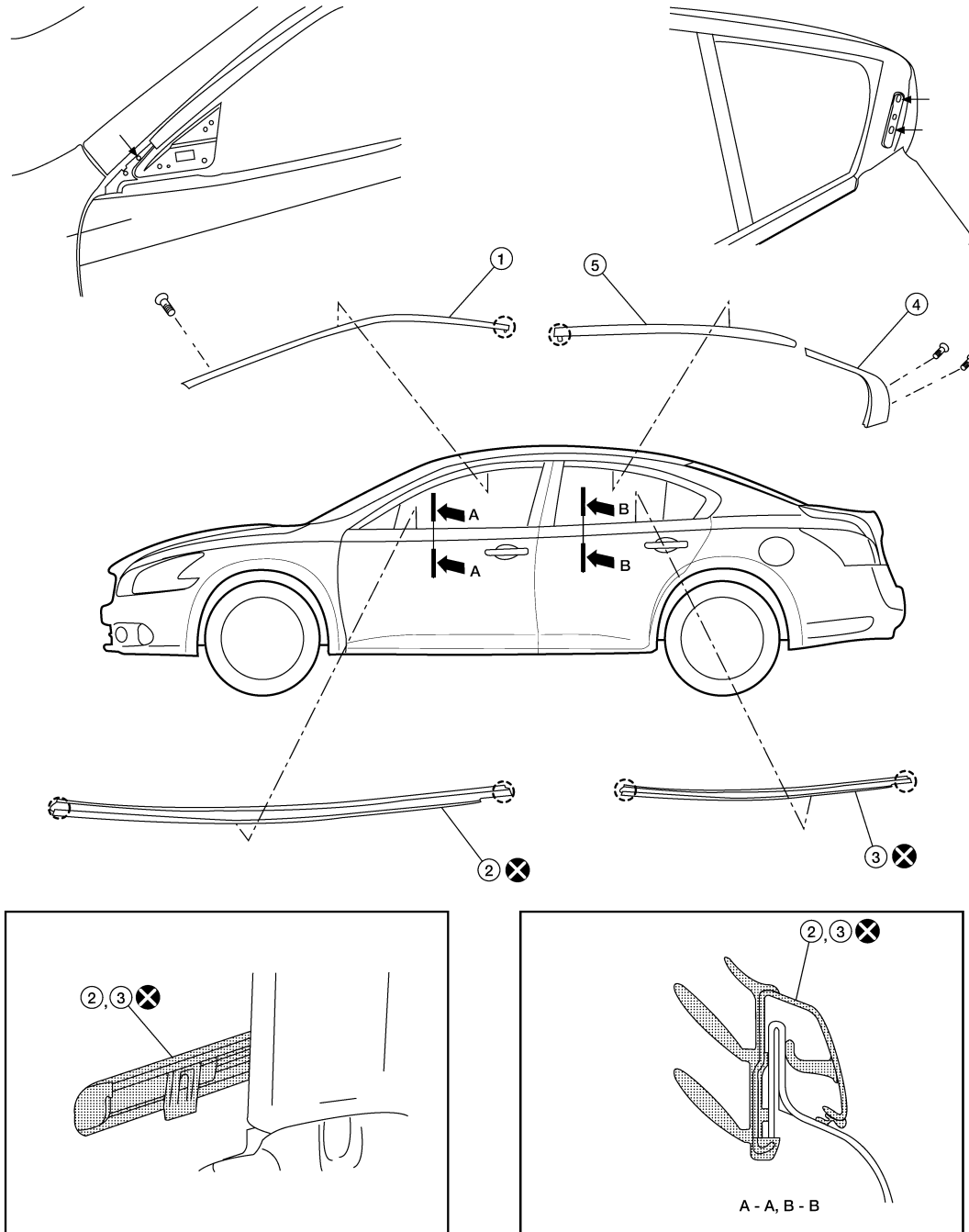

ALKIA1589ZZ

- | | | |
|-----------------------------------|-----------------------------------|------------------------------|
| 1. Front door sash molding | 2. Front door outside molding | 3. Rear door outside molding |
| 4. Rear door sash molding (lower) | 5. Rear door sash molding (upper) | ○ Pawl |

Removal and Installation

INFOID:000000009465819

FRONT DOOR OUTSIDE MOLDING

DOOR OUTSIDE MOLDING

< REMOVAL AND INSTALLATION >

Removal

1. Open the front door window fully.
2. Remove the side view mirror. Refer to [MIR-19, "Removal and Installation"](#).
3. Using a suitable trim tool (A), lift front door outside molding (1) enough to carefully insert a suitable release tool (B) beneath.

△: Clip

CAUTION:

Apply protection tape (C) around entire work area.

4. Release the clip from rear of front door panel flange.

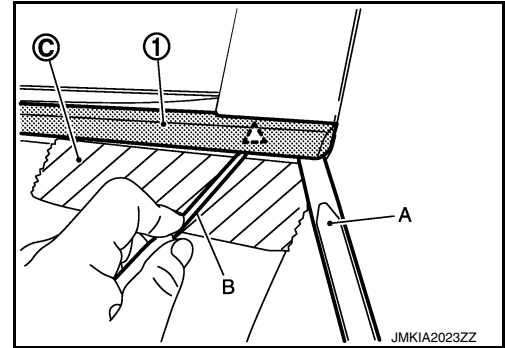

5. Lift and twist front door outside molding (1) upward, then out from door panel flange.

6. Release the clip from the front of door panel flange.

CAUTION:

Use care not to damage body surfaces.

7. Remove front door outside molding.

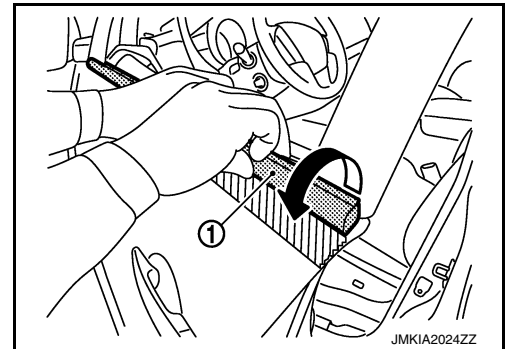

Installation

Installation is in the reverse order of removal.

REAR DOOR OUTSIDE MOLDING

Removal

1. Open the rear door window fully.
2. Using a suitable trim tool (A), lift rear door outside molding (1) enough to carefully insert a suitable release tool (B) beneath.

△: Clip

CAUTION:

Apply protection tape (C) around entire work area.

3. Release the clip from the rear of door panel flange.
4. Lift and twist rear door outside molding (1) up, then outward from door panel flange

5. Release the clip from the front of door panel flange.

CAUTION:

Use care not to damage body surfaces.

6. Remove rear door outside molding.

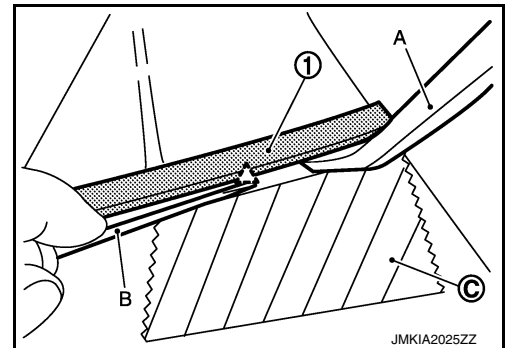

Installation

Installation is in the reverse order of removal.

FRONT DOOR SASH MOLDING

Removal

1. Open the front door window fully.
2. Remove front edge of front door weatherstrip, then remove front door sash molding screw.
3. Using a suitable tool, beginning at the front edge, release the front door sash molding working rearward.
4. Release the front door sash molding rear clip, then remove molding.

Installation

A
B
C
D
E
F
G
H
I
J
L
M
N
O
P

EXT

DOOR OUTSIDE MOLDING

< REMOVAL AND INSTALLATION >

Installation is in the reverse order of removal.

REAR DOOR SASH MOLDING

Removal

1. Open the rear door window fully.
2. Release the upper half of rear door weatherstrip.
3. Release the rear door sash molding (upper) front clip, then pull molding forward in vehicle to disengage from rear door sash molding (lower).
4. Remove the rear door sash molding (lower) screws, then with a suitable tool release the adhesive tape.
5. Remove rear door sash molding (lower) from rear door.

Installation

Installation is in the reverse order of removal.

ROOF SIDE MOLDING

< REMOVAL AND INSTALLATION >

ROOF SIDE MOLDING

Exploded View

INFOID:000000009465820

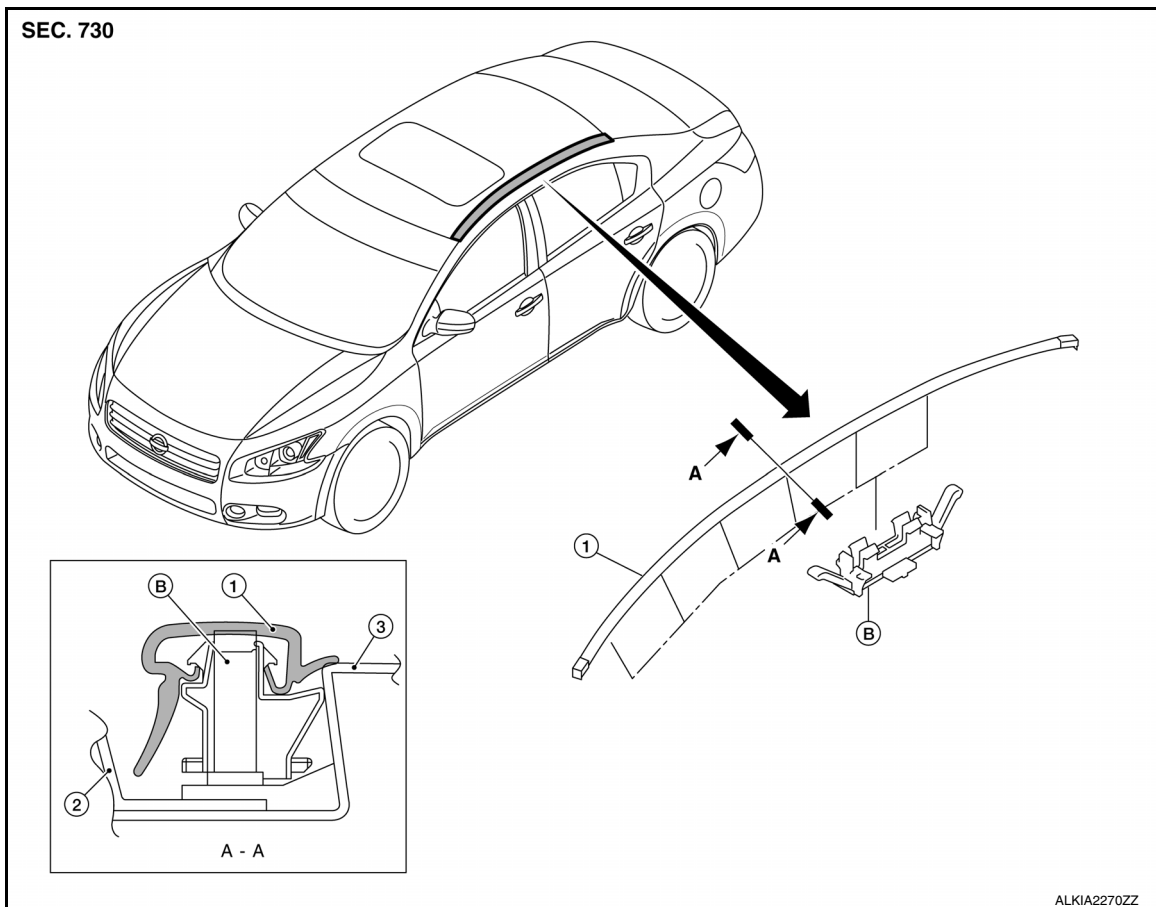

1. Roof side molding

2. Roof panel

3. Body side panel

B. Roof side molding clip

EXT

Removal and Installation

INFOID:000000009465821

REMOVAL

1. Using suitable tool, lift and twist the roof side molding up from the rear edge, working forward.
2. Disengage each roof side molding clip, then remove the roof side molding.

INSTALLATION

Installation is in the reverse order of removal.

- Begin with aligning rear end of the roof molding with top edge of rear window glass molding. Refer to [GW-14, "Removal and Installation"](#).

Clip Replacement

INFOID:000000009465822

REMOVAL

1. Remove roof side molding.
2. Heat adhesive tape interface using a suitable tool (heat gun), then peel roof side molding clips (body side) using long-nose pliers.

CAUTION:

Be careful not to damage the body.

INSTALLATION

ROOF SIDE MOLDING

< REMOVAL AND INSTALLATION >

1. Clean tape removed surface with a shop cloth soaked in white gasoline or IPA.
2. Use two-part epoxy adhesive.

Adhesive : 3M-weld DP-100 or equivalent

3. Apply adhesive evenly to clip tape surface.

Thickness : Approximately 0.5 mm (0.020 in)

4. Position applied parts to the proper location, and then sufficiently press-fit until the adhesive protrudes to tape side.

Press-fit limit : 19.6 N× 2 seconds

5. Tape clips after press fit, and temporarily hold it for specified time based on the following.

5 to 10°C (41 to 50°F) : 1 hour or more

11 to 23°C (52 to 73°F) : 30 minutes or more

24°C or more (75°F or more) : 15 minutes or more

6. Install roof side molding rear edge first, working toward front after temporarily holding.

CAUTION:

- Securely insert molding rear end cap onto roof rear end cutout (installation standard).
- When installing roof side molding, check that molding fastener is securely inserted and then press in.
- Do not wash the vehicle within 24 hours after repair.

LICENSE LAMP FINISHER

< REMOVAL AND INSTALLATION >

LICENSE LAMP FINISHER

Exploded View

INFOID:000000009465823

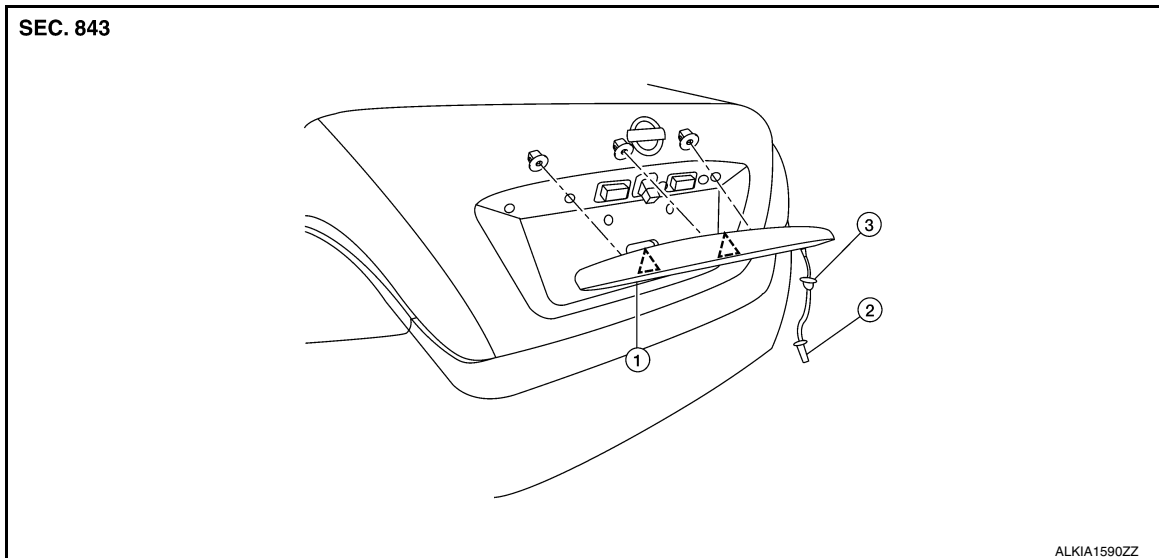

- 1. License lamp finisher
- 2. Trunk request switch connector
- 3. Grommet

 Clip

Removal and Installation

INFOID:000000009465824

REMOVAL

1. Remove the trunk lid finisher. Refer to [INT-36. "Removal and Installation"](#).
2. Disconnect the harness connector (1) from the trunk request switch.
3. Remove the license lamp finisher nuts.
4. Release the clips, then loosen trunk request switch harness grommet from trunk.
5. Remove license lamp finisher by pulling out and rearward away from trunk.

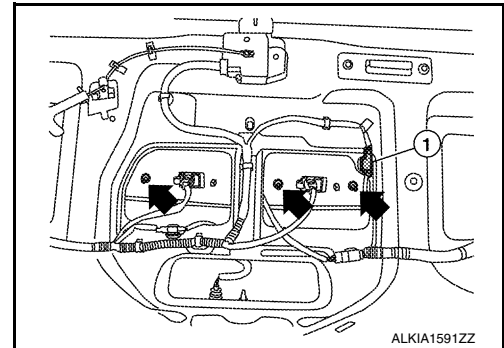

INSTALLATION

Installation is in the reverse order of removal.

A
B
C
D
E
F
G
H
I
J
EXT
L
M
N
O
P

REAR SPOILER

< REMOVAL AND INSTALLATION >

REAR SPOILER

Exploded View

INFOID:000000009465825

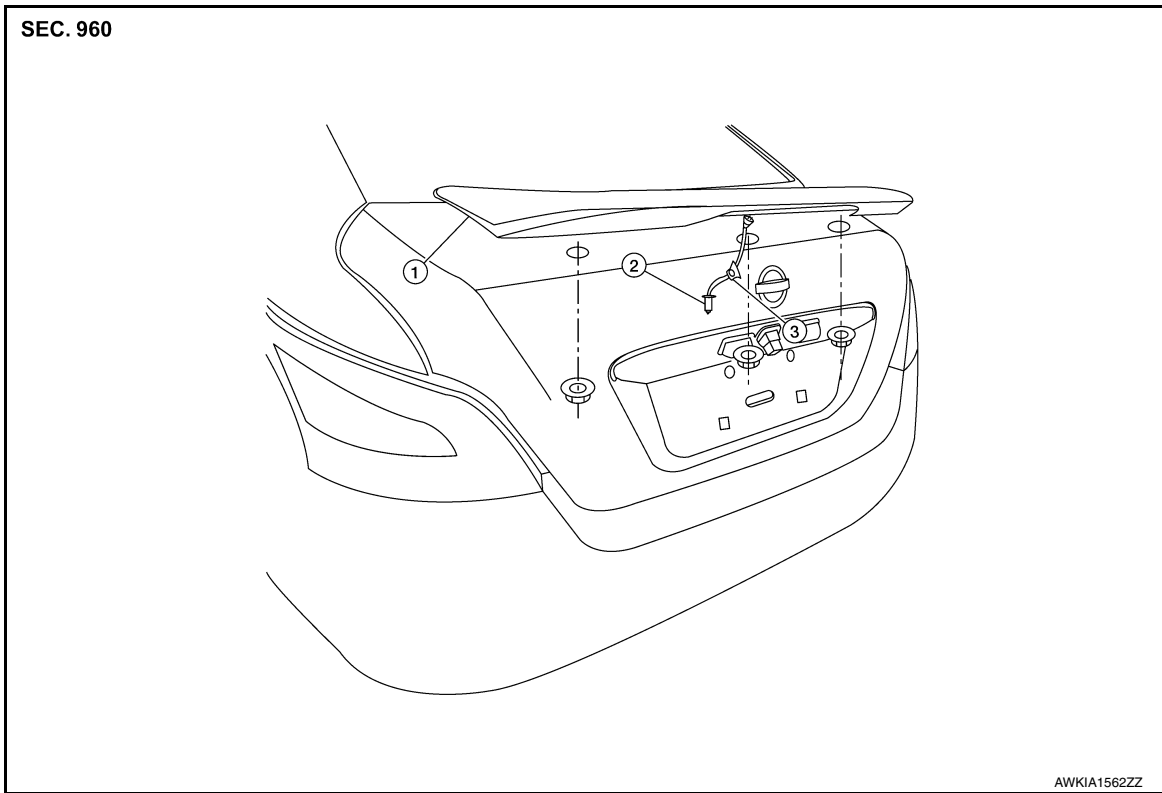

1. Rear spoiler assembly 2. High-mounted stop lamp harness connector 3. Harness grommet

Removal and Installation

INFOID:000000009465826

Removal

1. Remove trunk lid finisher. Refer to [INT-36. "Removal and Installation"](#).
2. Disconnect the harness connector (1) from the high-mounted stop lamp.
3. Remove the rear spoiler assembly nuts.

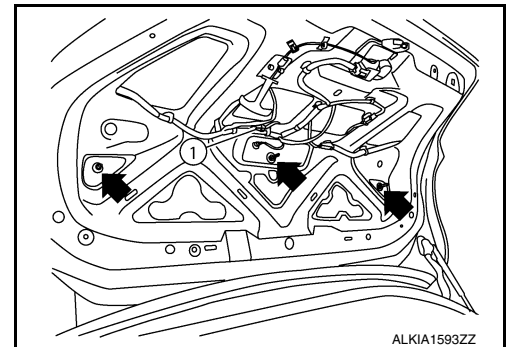

REAR SPOILER

< REMOVAL AND INSTALLATION >

- Using a suitable heating tool (A) may also be necessary to evenly heat the rear spoiler contact surface (1) while releasing the tape with a suitable tool (B).
- Loosen the harness grommet, and gently lift the rear spoiler assembly upward off of trunk lid.

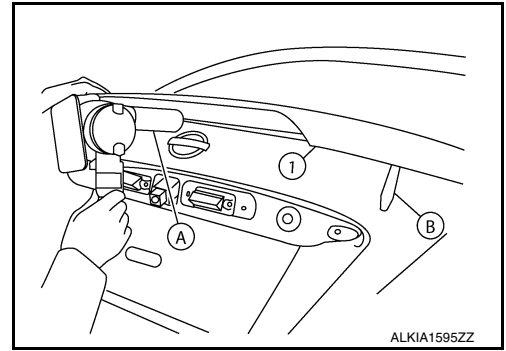

Installation

Installation is in the reverse order of removal.

NOTE:

- Before installing rear spoiler, clean the surface where it will be mounted with isopropyl alcohol or equivalent to degrease the surface.
- Before installing, be sure there are no gaps or waves in the adhesive-backed foam tape where the surfaces meet.
- During installation, be sure harness grommet of high-mounted stop lamp is fully seated into trunk lid opening prior to final rear spoiler assembly placement.

A
B
C
D
E
F
G
H
I
J
L
M
N
O
P

EXT