

A
EM
C
D
E
F
G
H
I
J
K
L
M
N
O
P

SECTION **EM**

ENGINE MECHANICAL

CONTENTS

<p>PRECAUTION 3</p> <p>PRECAUTIONS 3</p> <p style="padding-left: 20px;">Precaution for Supplemental Restraint System (SRS) "AIR BAG" and "SEAT BELT PRE-TENSIONER"3</p> <p style="padding-left: 20px;">Precaution for Drain Coolant3</p> <p style="padding-left: 20px;">Precaution for Disconnecting Fuel Piping3</p> <p style="padding-left: 20px;">Precaution for Removal and Disassembly3</p> <p style="padding-left: 20px;">Precaution for Inspection, Repair and Replacement3</p> <p style="padding-left: 20px;">Precaution for Assembly and Installation3</p> <p style="padding-left: 20px;">Special Cautions to Ensure the Safe Disposal of Sodium-filled Exhaust Valves4</p> <p style="padding-left: 20px;">Parts Requiring Angular Tightening5</p> <p style="padding-left: 20px;">Precaution for Liquid Gasket5</p> <p>PREPARATION 7</p> <p>PREPARATION 7</p> <p style="padding-left: 20px;">Special Service Tools7</p> <p style="padding-left: 20px;">Commercial Service Tool8</p> <p>SYSTEM DESCRIPTION12</p> <p>NOISE, VIBRATION, AND HARSHNESS (NVH) TROUBLESHOOTING12</p> <p style="padding-left: 20px;">NVH Troubleshooting - Engine Noise12</p> <p style="padding-left: 20px;">Use the Chart Below to Help You Find the Cause of the Symptom13</p> <p>PERIODIC MAINTENANCE14</p> <p>SPARK PLUG14</p> <p style="padding-left: 20px;">Exploded View14</p> <p style="padding-left: 20px;">Removal and Installation14</p> <p>DRIVE BELTS16</p> <p style="padding-left: 20px;">Exploded View16</p> <p style="padding-left: 20px;">Checking Drive Belt16</p> <p style="padding-left: 20px;">Tension Adjustment16</p> <p style="padding-left: 20px;">Removal and Installation16</p>	<p style="padding-left: 20px;">Removal and Installation of Drive Belt Auto-tensioner18</p> <p>AIR CLEANER FILTER19</p> <p style="padding-left: 20px;">Removal and Installation19</p> <p>CAMSHAFT VALVE CLEARANCE20</p> <p style="padding-left: 20px;">Valve Clearance20</p> <p>COMPRESSION PRESSURE24</p> <p style="padding-left: 20px;">On-Vehicle Service24</p> <p>REMOVAL AND INSTALLATION25</p> <p>ENGINE ROOM COVER25</p> <p style="padding-left: 20px;">Exploded View25</p> <p style="padding-left: 20px;">Removal and Installation25</p> <p>AIR CLEANER AND AIR DUCT26</p> <p style="padding-left: 20px;">Removal and Installation26</p> <p>INTAKE MANIFOLD COLLECTOR27</p> <p style="padding-left: 20px;">Removal and Installation27</p> <p>INTAKE MANIFOLD30</p> <p style="padding-left: 20px;">Exploded View30</p> <p style="padding-left: 20px;">Removal and Installation30</p> <p>EXHAUST MANIFOLD AND THREE WAY CATALYST32</p> <p style="padding-left: 20px;">Exploded View32</p> <p style="padding-left: 20px;">Removal and Installation (bank 2)32</p> <p style="padding-left: 20px;">Removal and Installation (bank 1)34</p> <p>THREE WAY CATALYST36</p> <p style="padding-left: 20px;">Exploded View36</p> <p style="padding-left: 20px;">Removal and Installation (bank 2)36</p> <p style="padding-left: 20px;">Removal and Installation (bank 1)37</p> <p>OIL PAN AND OIL STRAINER39</p> <p style="padding-left: 20px;">Exploded View39</p> <p style="padding-left: 20px;">Removal and Installation (Lower Oil Pan)39</p> <p style="padding-left: 20px;">Removal and Installation (Upper Oil Pan)40</p>
---	---

IGNITION COIL	45	Removal and Installation	91
Exploded View	45	Disassembly and Assembly	94
Removal and Installation (LH)	45	Inspection After Disassembly	97
Removal and Installation (RH)	45		
FUEL INJECTOR AND FUEL TUBE	46	ENGINE MOUNT	101
Exploded View	46	ENGINE MOUNT (FRONT)	101
Removal and Installation	46	ENGINE MOUNT (FRONT) : Removal and Instal-	
Inspection	50	lation	101
ROCKER COVER	51	ENGINE MOUNT (REAR)	103
Exploded View	51	ENGINE MOUNT (REAR) : Removal and Installa-	
Removal and Installation (LH)	51	tion	103
Removal and Installation (RH)	52	UNIT REMOVAL AND INSTALLATION ...	107
VALVE TIMING CONTROL	55	ENGINE ASSEMBLY	107
Exploded View	55	Removal and Installation	107
Valve Timing Control Cover (bank 1)	55	UNIT DISASSEMBLY AND ASSEMBLY ..	115
Valve Timing Control Cover (bank 2)	56	CYLINDER BLOCK	115
FRONT TIMING CHAIN CASE	58	Exploded View	115
Exploded View	58	Disassembly and Assembly	116
Removal and Installation	58	Inspection	126
TIMING CHAIN	66	Dowel Pin Alignment	137
Exploded View	66	SERVICE DATA AND SPECIFICATIONS	
Removal and Installation	66	(SDS)	139
REAR TIMING CHAIN CASE	74	SERVICE DATA AND SPECIFICATIONS	
Exploded View	74	(SDS)	139
Removal and Installation	74	General Specification	139
CAMSHAFT	79	Drive Belt	139
Exploded View	79	Spark Plug	140
Removal and Installation	79	Intake Manifold	140
Inspection after Installation	86	Exhaust Manifold	140
OIL SEAL	87	Camshaft	140
Removal and Installation of Valve Oil Seal	87	Cylinder Head	142
Removal and Installation of Front Oil Seal	88	Cylinder Block	146
Removal and Installation of Rear Oil Seal	89	Main Bearing	149
CYLINDER HEAD	91	Connecting Rod Bearing	150
Exploded View	91	Drive Plate	151

PRECAUTIONS

< PRECAUTION >

PRECAUTION

PRECAUTIONS

Precaution for Supplemental Restraint System (SRS) "AIR BAG" and "SEAT BELT PRE-TENSIONER"

INFOID:000000012378528

The Supplemental Restraint System such as "AIR BAG" and "SEAT BELT PRE-TENSIONER", used along with a front seat belt, helps to reduce the risk or severity of injury to the driver and front passenger for certain types of collision. Information necessary to service the system safely is included in the SR and SB section of this Service Manual.

WARNING:

- To avoid rendering the SRS inoperative, which could increase the risk of personal injury or death in the event of a collision which would result in air bag inflation, all maintenance must be performed by an authorized NISSAN/INFINITI dealer.
- Improper maintenance, including incorrect removal and installation of the SRS, can lead to personal injury caused by unintentional activation of the system. For removal of Spiral Cable and Air Bag Module, see the SR section.
- Do not use electrical test equipment on any circuit related to the SRS unless instructed to in this Service Manual. SRS wiring harnesses can be identified by yellow and/or orange harnesses or harness connectors.

PRECAUTIONS WHEN USING POWER TOOLS (AIR OR ELECTRIC) AND HAMMERS

WARNING:

- When working near the Airbag Diagnosis Sensor Unit or other Airbag System sensors with the Ignition ON or engine running, DO NOT use air or electric power tools or strike near the sensor(s) with a hammer. Heavy vibration could activate the sensor(s) and deploy the air bag(s), possibly causing serious injury.
- When using air or electric power tools or hammers, always switch the Ignition OFF, disconnect the battery and wait at least three minutes before performing any service.

Precaution for Drain Coolant

INFOID:000000011933729

- Drain coolant when engine is cooled.

Precaution for Disconnecting Fuel Piping

INFOID:000000011933730

- Before starting work, make sure no fire or spark producing items are in the work area.
- Release fuel pressure before disassembly.
- After disconnecting pipes, plug openings to stop fuel leakage.

Precaution for Removal and Disassembly

INFOID:000000011933731

- When instructed to use special service tools, use the specified tools. Always be careful to work safely, avoid forceful or uninstructed operations.
- Exercise maximum care to avoid damage to mating or sliding surfaces.
- Cover openings of engine system with tape or the equivalent, if necessary, to seal out foreign materials.
- Mark and arrange disassembly parts in an organized way for easy troubleshooting and assembly.
- When loosening nuts and bolts, as a basic rule, start with the one furthest outside, then the one diagonally opposite, and so on. If the order of loosening is specified, do exactly as specified. Power tools may be used where noted in the step.

Precaution for Inspection, Repair and Replacement

INFOID:000000011933732

- Before repairing or replacing, thoroughly inspect parts. Inspect new replacement parts in the same way, and replace if necessary.

Precaution for Assembly and Installation

INFOID:000000011933733

- Use torque wrench to tighten bolts or nuts to specification.

PRECAUTIONS

< PRECAUTION >

- When tightening nuts and bolts, as a basic rule, equally tighten in several different steps starting with the ones in center, then ones on inside and outside diagonally in this order. If the order of tightening is specified, do exactly as specified.
- Replace with new gasket, packing, oil seal or O-ring.
- Thoroughly wash, clean, and air-blow each part. Carefully check oil or coolant passages for any restriction and blockage.
- Avoid damaging sliding or mating surfaces. Completely remove foreign materials such as cloth lint or dust. Before assembly, oil sliding surfaces well.
- Release air within route after draining coolant.
- Before starting engine, apply fuel pressure to fuel lines with turning ignition switch ON (with engine stopped). Then make sure that there are no leaks at fuel line connections.
- After repairing, start engine and increase engine speed to check coolant, fuel, oil, and exhaust systems for leakage.

Special Cautions to Ensure the Safe Disposal of Sodium-filled Exhaust Valves

INFOID:000000012378531

Handling and disposal of sodium-filled exhaust valves requires special care and consideration. Under conditions such as breakage with subsequent contact with water, metal sodium which lines the inner portion of exhaust valve will react violently, forming sodium hydroxide and hydrogen which may result in an explosion. Sodium-filled exhaust valve is identified on the top of its stem as shown in illustration.

(A) : Identification mark of sodium-filled exhaust valve

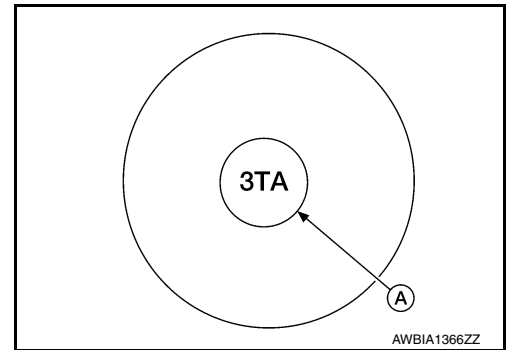

DEALER DISPOSAL INSTRUCTIONS

CAUTION:

- Use approved shatter-resistant eye protection when performing this procedure.
- Perform this and all subsequent disposal work procedures in an open room, away from flammable liquids. Keep a fire extinguisher, rated at least 10 ABC, in close proximity to the work area.
- Be sure to wear rubber gloves when performing the following operations.
- Make sure the resultant (high alkalinity) waste water does not contact your skin. If the waste water does contact you, wash the contacted area immediately with large quantities of water.
- Dealers should check their respective state and local regulations concerning any chemical treatment or waste water discharge permits which may be required to dispose of the resultant (high alkalinity) waste water.

1. Clamp valve stem in a vice.
2. The valve has a specially-hardened surface. To cut through it, first remove a half-round section, approximately 30 mm (1.18 in) long using air-powered grinder until black color is removed and silver color appears.

- (A) : Black color
(B) : Silver color
(c) : 47 mm (1.85 in)
(d) : 17 mm (0.67 in)

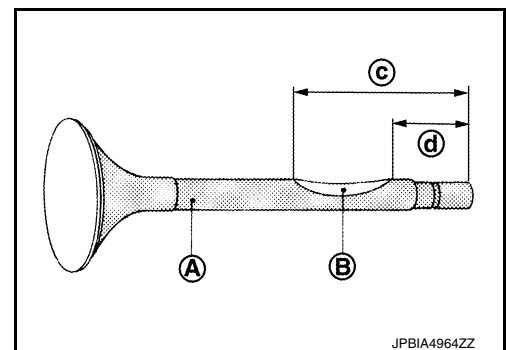

PRECAUTIONS

< PRECAUTION >

3. Use hacksaw to cut through approximately half the diameter of valve stem. Make the serration at a point 40 mm (1.57 in) from the end of valve stem.

(a) : 40 mm (1.57 in)

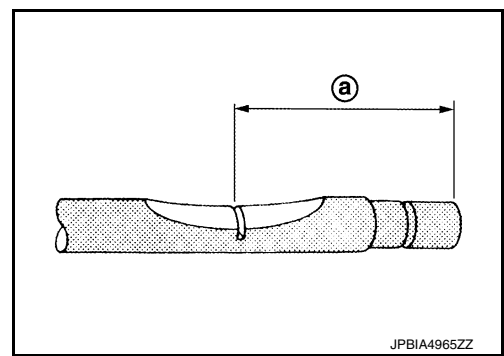

4. Cover the serrated end of the valve with a large shop towel (A). Strike the valve face end with a hammer, separating it into two pieces.
5. Fill a bucket, such as a 20 ℓ (5-1/4 US gal, 4-3/8 Imp gal) oil can, with at least 10 ℓ (2-5/8 US gal, 2-1/4 Imp gal) of water. Carefully place the already cut (serrated) valves into the water one-at-a-time using a set of large tweezers and quickly move away at least 2.7 m (9 ft).

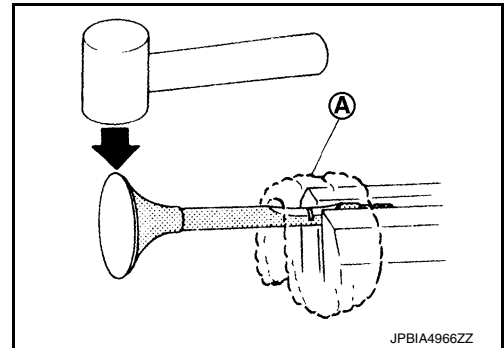

6. The valves should be placed in a standing position as shown in the illustration to allow complete reaction. After the bubbling action has subsided, additional valves can be placed into the bucket allowing each subsequent chemical reaction to subside. However, no more than 8 valves should be placed in the same 10 ℓ (2-5/8 US gal, 2-1/4 Imp gal) amount of water. The complete chemical reaction may take as long as 4 to 5 hours. Remove the valves using a set of large tweezers after the chemical reaction has stopped. Afterwards, valves can be disposed as ordinary scrap.

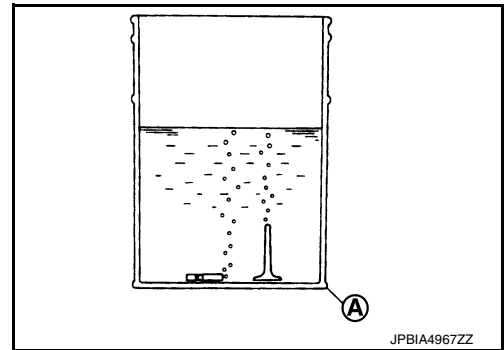

A : Bucket [Such as 20 ℓ (5-1/4 US gal, 4-3/8 Imp gal) oil can]

Parts Requiring Angular Tightening

INFOID:000000011933734

- Use an angle wrench for the final tightening of the following engine parts:
 - Cylinder head bolts
 - Main bearing cap bolts
 - Connecting rod cap nuts
 - Crankshaft pulley bolt (No angle wrench is required as the bolt flange is provided with notches for angular tightening)
- Do not use a torque value for final tightening.
- The torque value for these parts are for a preliminary step.
- Ensure thread and seat surfaces are clean and coated with engine oil.

Precaution for Liquid Gasket

INFOID:000000012229205

REMOVAL OF LIQUID GASKET SEALING

PRECAUTIONS

< PRECAUTION >

- After removing the bolts and nuts, separate the mating surface and remove the liquid gasket using Tool (A).

Tool Number : KV10111100 (J-37228)

CAUTION:

Be careful not to damage the mating surfaces.

- In areas where the cutter is difficult to use, use a plastic hammer to lightly tap (1) the cutter where the liquid gasket is applied. Use a plastic hammer to slide (2) the cutter by tapping on the side.

CAUTION:

Do not damage the mating surfaces.

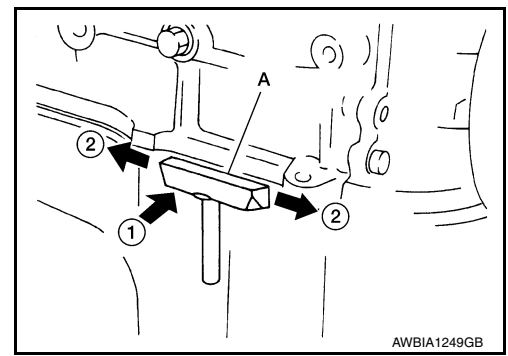

LIQUID GASKET APPLICATION PROCEDURE

1. Using suitable tool (A), remove old liquid gasket adhering to the liquid gasket application surface and the mating surface.
 - Remove liquid gasket completely from the groove of the liquid gasket application surface, mounting bolts, and bolt holes.
2. Thoroughly clean the mating surfaces and remove adhering moisture, grease and foreign materials.

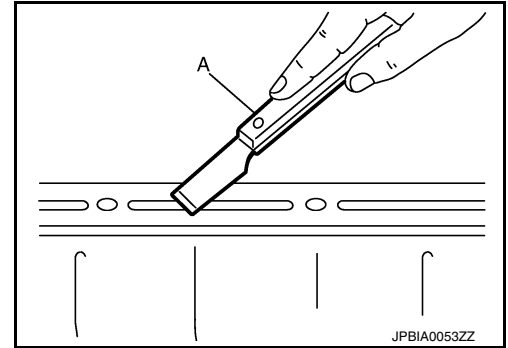

3. Attach liquid gasket tube to the suitable tool.
Use Genuine Silicone RTV Sealant, or equivalent. Refer to [GI-22, "Recommended Chemical Products and Sealants"](#).
4. Apply liquid gasket without gaps to the specified location according to the specified dimensions.
 - If there is a groove for liquid gasket application, apply liquid gasket to the groove.

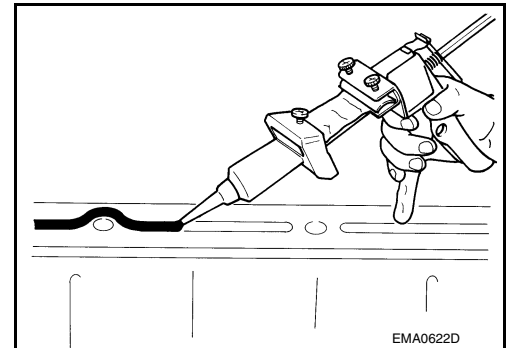

- As for bolt holes (B), normally apply liquid gasket inside the holes. Occasionally, it should be applied outside the holes. Check to read the text of this manual.

(A) : Groove

↔ : Inside

- Within five minutes of liquid gasket application, install the mating component.
- If liquid gasket protrudes, wipe it off immediately.
- Do not retighten mounting bolts or nuts after the installation.
- After 30 minutes or more have passed from the installation, fill engine oil and engine coolant. Refer to [LU-9, "Changing Engine Oil"](#) and [CO-12, "Changing Engine Coolant"](#).

CAUTION:

If there are more specific instructions in the procedures contained in this manual concerning liquid gasket application, observe them.

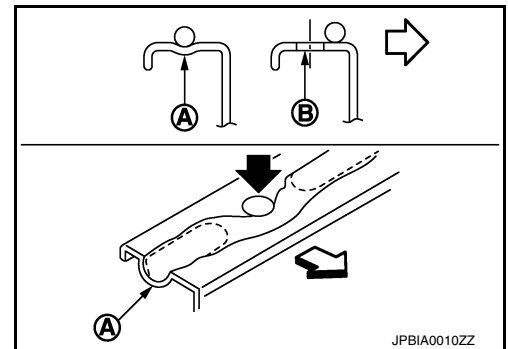

PREPARATION

< PREPARATION >

PREPARATION

PREPARATION



Special Service Tools

INFOID:0000000012493232

A

EM

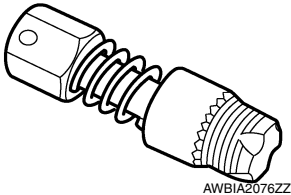
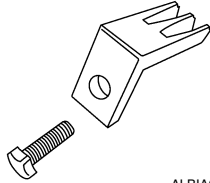
The actual shape of the tools may differ from those illustrated here.

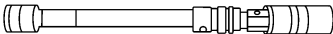
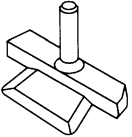
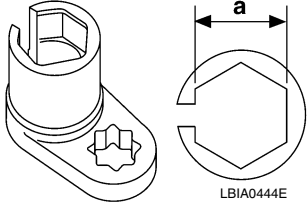
Tool number (TechMate No.) Tool name	Description
(J-43897-18) Oxygen sensor thread cleaner  <p style="text-align: right; font-size: small;">AWBIA2076ZZ</p>	Reconditioning the exhaust system threads before installing a new oxygen sensor (Use with anti-seize lubricant shown below.) J-43897-18 (18 mm dia.) for zirconia oxygen sensor
— (J-50288) Ring gear stopper  <p style="text-align: right; font-size: small;">ALBIA0675ZZ</p>	Removing and installing crankshaft pulley
16441 6N210 (J-45488) Quick connector release  <p style="text-align: right; font-size: small;">PBIC0198E</p>	Removing fuel tube quick connectors in engine room (Available in SEC. 164 of PARTS CATALOG: Part No. 16441 6N210)
— (J-48891) Spark plug socket  <p style="text-align: right; font-size: small;">AWBIA1785ZZ</p>	Removing and installing spark plug
KV10111100 (J-37228) Seal cutter  <p style="text-align: right; font-size: small;">S-NT046</p>	Removing oil pan and timing chain case
KV991J0050 (J-44626) Air fuel sensor Socket  <p style="text-align: right; font-size: small;">LBIA0444E</p>	Loosening or tightening air fuel ratio A/F sensor a: 22 mm (0.87 in)

C

D

E

F

G

H

I

J

K

L

M

N

O

P

PREPARATION

< PREPARATION >

Tool number (TechMate No.) Tool name	Description
KV10114400 (J-38365) Heated oxygen sensor wrench	Loosening or tightening rear heated oxygen sensor a: 22 mm (0.87 in)
— (J-37066) Seal installer	Installing front main seal
— (J-47128) Seal installer	Installing rear main seal
KV10112100 (BT-8653-A) Torque angle meter	Tightening bolts for bearing cap, cylinder head, etc.

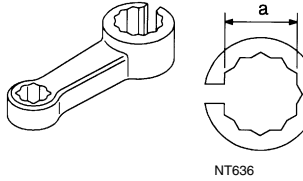

NT636

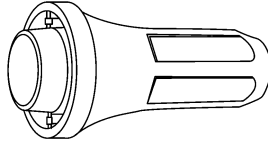

AWBIA2081ZZ

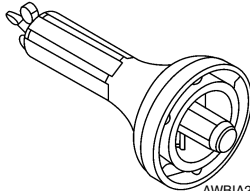

AWBIA2551ZZ

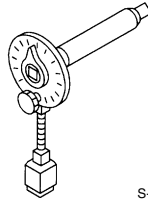

S-NT014

Commercial Service Tool

INFOID:000000012493233

Tool number (TechMate No.) Tool name	Description
KV10116200 (J-26336-A) Valve spring compressor 1. KV10115900 (J-26336-20) Attachment 2. KV10109220 (—) Adapter	Disassembling valve mechanism Part (1) is a component of KV10116200 (J-26336-A), but part (2) is not.
Manual lift table caddy	Removing and installing engine

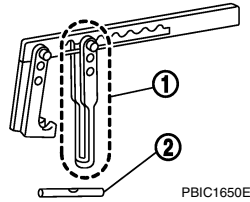

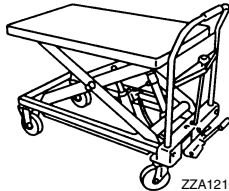

PBIC1650E



ZZA1210D

PREPARATION

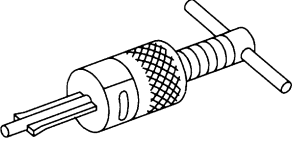
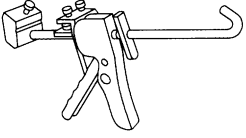
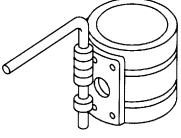
< PREPARATION >

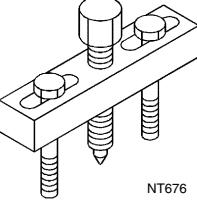
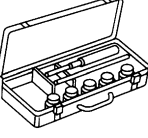
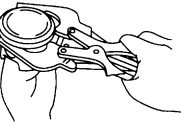
Tool number (TechMate No.) Tool name	Description	A
ST16610001 (J-23907) Pilot converter puller  S-NT045	Removing crankshaft pilot converter	EM C
Tube presser  S-NT052	Pressing the tube of liquid gasket	D E F
Piston ring compressor  S-NT044	Installing piston assembly into cylinder bore	G H
Pulley holder  ZZA1010D	Crankshaft pulley removing and installing	I J
Pulley puller  NT676	Removing crankshaft pulley	K L M
Valve seat cutter set  S-NT048	Finishing valve seat dimensions	N O
Piston ring expander  S-NT030	Removing and installing piston ring	P

PREPARATION

< PREPARATION >

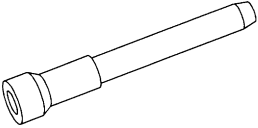
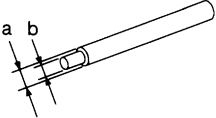
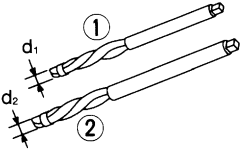
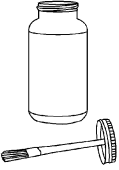
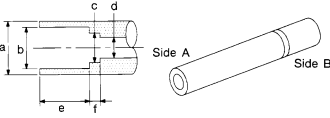
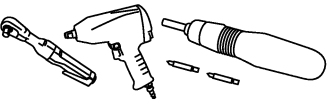
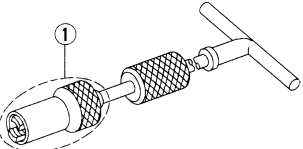
Tool number (TechMate No.) Tool name	Description
<p>— (J-39386) Valve oil seal drift</p>  <p style="text-align: center;">NT024</p>	<p>Installing valve oil seal</p>
<p>Valve guide drift</p>  <p style="text-align: center;">S-NT015</p>	<p>Removing and installing valve guide Intake & Exhaust: a: 9.5 mm (0.374 in) dia. b: 5.5 mm (0.217 in) dia.</p>
<p>Valve guide reamer</p>  <p style="text-align: center;">S-NT016</p>	<p>1: Reaming valve guide inner hole 2: Reaming hole for oversize valve guide Intake & Exhaust: d1: 6.0 mm (0.236 in) dia. d2: 10.2 mm (0.402 in) dia.</p>
<p>Anti-seize lubricant (Permatex 133AR or equivalent meeting MIL specifica- tion MIL-A-907)</p>  <p style="text-align: center;">AEM489</p>	<p>Lubricating oxygen sensor thread cleaning tool when reconditioning exhaust system threads</p>
<p>KV10115600 (J-38958) Valve oil seal drift</p>  <p style="text-align: center;">S-NT603</p>	<p>Installing valve oil seal Use side A. a: 20 (0.79) dia. d: 8 (0.31) dia. b: 13 (0.51) dia. e: 10.7 (0.421) dia. c: 10.3 (0.406) dia. f: 5 (0.20) dia. Unit: mm (in)</p>
<p>Power tool</p>  <p style="text-align: center;">PIIB1407E</p>	<p>Loosening nuts, screws, and bolts</p>
<p>KV10107902 (J-38959) Valve oil seal puller with adapter (1)</p>  <p style="text-align: center;">S-NT605</p>	<p>Removing valve oil seal</p>

PREPARATION

< PREPARATION >

Tool number (TechMate No.) Tool name	Description
ST0501S000 Engine stand assembly (—) 1. ST05011000 (—) Engine stand 2. ST05012000 (—) Base	Disassembling and assembling
KV10106500 (—) Engine stand shaft	Engine supporting
KV10115300 (—) Engine sub-attachment	Disassembling and assembling
(J-45816) E20 ®Socket	Removing and installing CVT drive plate bolts

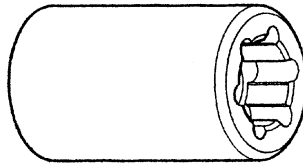
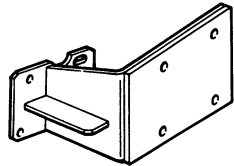
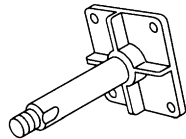
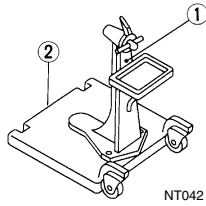

A
EM
C
D
E
F
G
H
I
J
K
L
M
N
O
P

NOISE, VIBRATION, AND HARSHNESS (NVH) TROUBLESHOOTING

< SYSTEM DESCRIPTION >

SYSTEM DESCRIPTION

NOISE, VIBRATION, AND HARSHNESS (NVH) TROUBLESHOOTING

NVH Troubleshooting - Engine Noise

INFOID:000000012219136

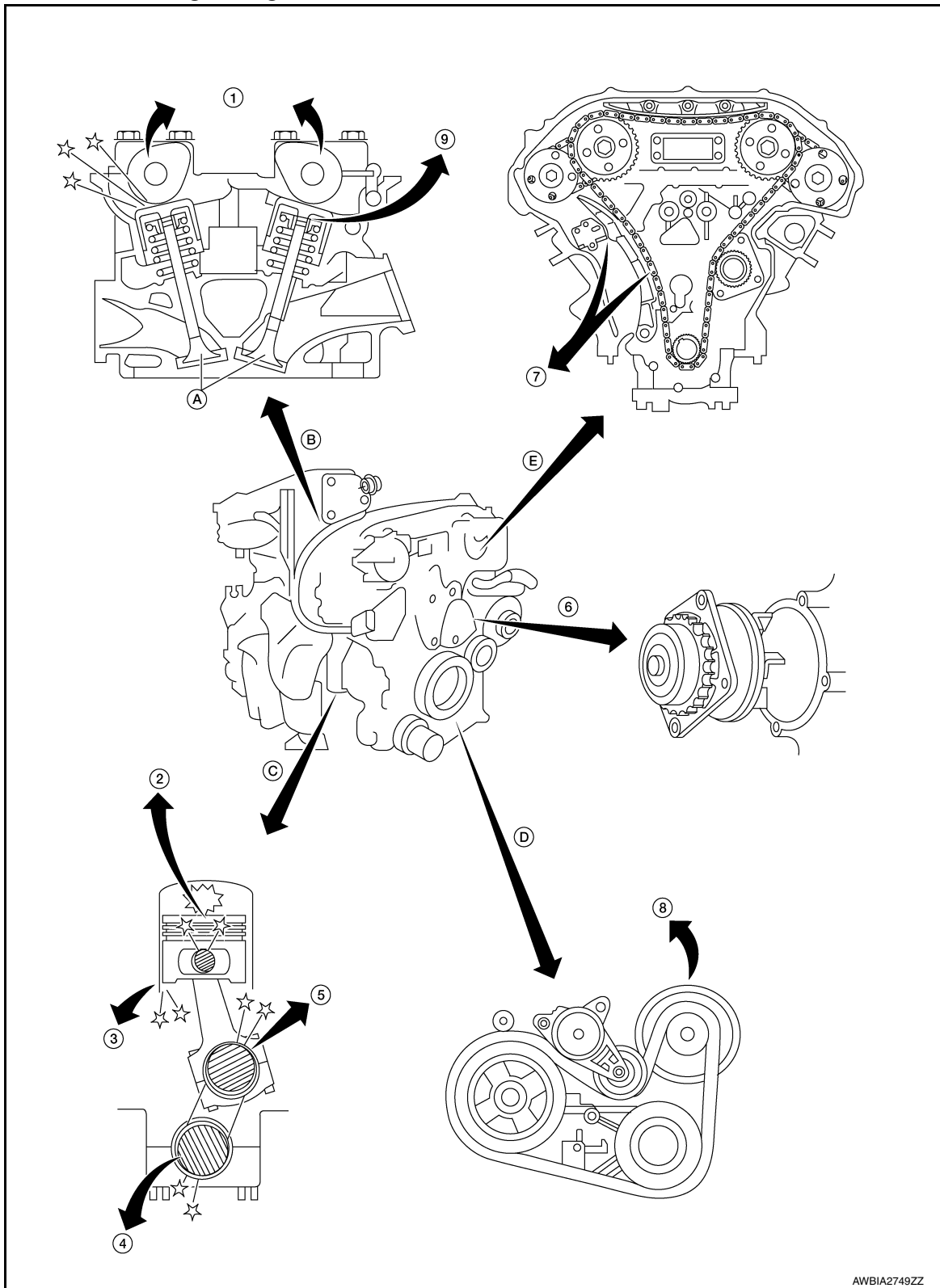

AWBIA2749ZZ

- | | | |
|---------------------------|---------------------------------|----------------------|
| 1. Camshaft bearing noise | 2. Piston pin noise | 3. Piston slap noise |
| 4. Main bearing noise | 5. Connecting rod bearing noise | 6. Water pump noise |

NOISE, VIBRATION, AND HARSHNESS (NVH) TROUBLESHOOTING

< SYSTEM DESCRIPTION >

- | | | |
|---|---|-----------------------|
| 7. Timing chain and chain tensioner noise | 8. Drive belt noise (Sticking/Slipping) | 9. Tappet noise |
| A. Valve | B. Valve mechanism | C. Rotation mechanism |
| D. Drive belt | E. Timing chain | |

Use the Chart Below to Help You Find the Cause of the Symptom

INFOID:000000011933739

1. Locate the area where noise occurs.
2. Confirm the type of noise.
3. Specify the operating condition of engine.
4. Check specified noise source. Repair or replace the identified part as necessary.

Location of noise	Type of noise	Operating condition of engine						Source of noise	Check item	Reference page
		Before warm-up	After warm-up	When starting	When idling	When racing	While driving			
Top of engine Rocker cover Cylinder head	Ticking or clicking	C	A	—	A	B	—	Tappet noise	Valve clearance	EM-20
	Rattle	C	A	—	A	B	C	Camshaft bearing noise	Camshaft journal clearance Camshaft runout	EM-79
Crankshaft pulley Cylinder block (Side of engine) Oil pan	Slap or knock	—	A	—	B	B	—	Piston pin noise	Piston and piston pin clearance Connecting rod bushing clearance	EM-24
	Slap or rap	A	—	—	B	B	A	Piston slap noise	Piston-to-bore clearance Piston ring side clearance Piston ring end gap Connecting rod bend and torsion	EM-126. "Inspection"
	Knock	A	B	C	B	B	B	Connecting rod bearing noise	Connecting rod bushing clearance (Small end) Connecting rod bearing clearance (Big end)	EM-126. "Inspection"
	Knock	A	B	—	A	B	C	Main bearing noise	Main bearing oil clearance Crankshaft runout	EM-126. "Inspection"
Front of engine Timing chain cover	Tapping or ticking	A	A	—	B	B	B	Timing chain and chain tensioner noise	Timing chain cracks and wear Timing chain tensioner operation	EM-58. "Exploded View"
Front of engine	Squeaking or fizzing	A	B	—	B	—	C	Drive belts (Sticking or slipping)	Drive belts deflection	EM-16. "Tension Adjustment"
	Creaking	A	B	A	B	A	B	Drive belts (Slipping)	Idler pulley bearing operation	
	Squall Creak	A	B	—	B	A	B	Water pump noise	Water pump operation	CO-18. "Removal and Installation"

A: Closely related B: Related C: Sometimes related —: Not related

SPARK PLUG

< PERIODIC MAINTENANCE >

PERIODIC MAINTENANCE

SPARK PLUG

Exploded View

INFOID:000000011933740

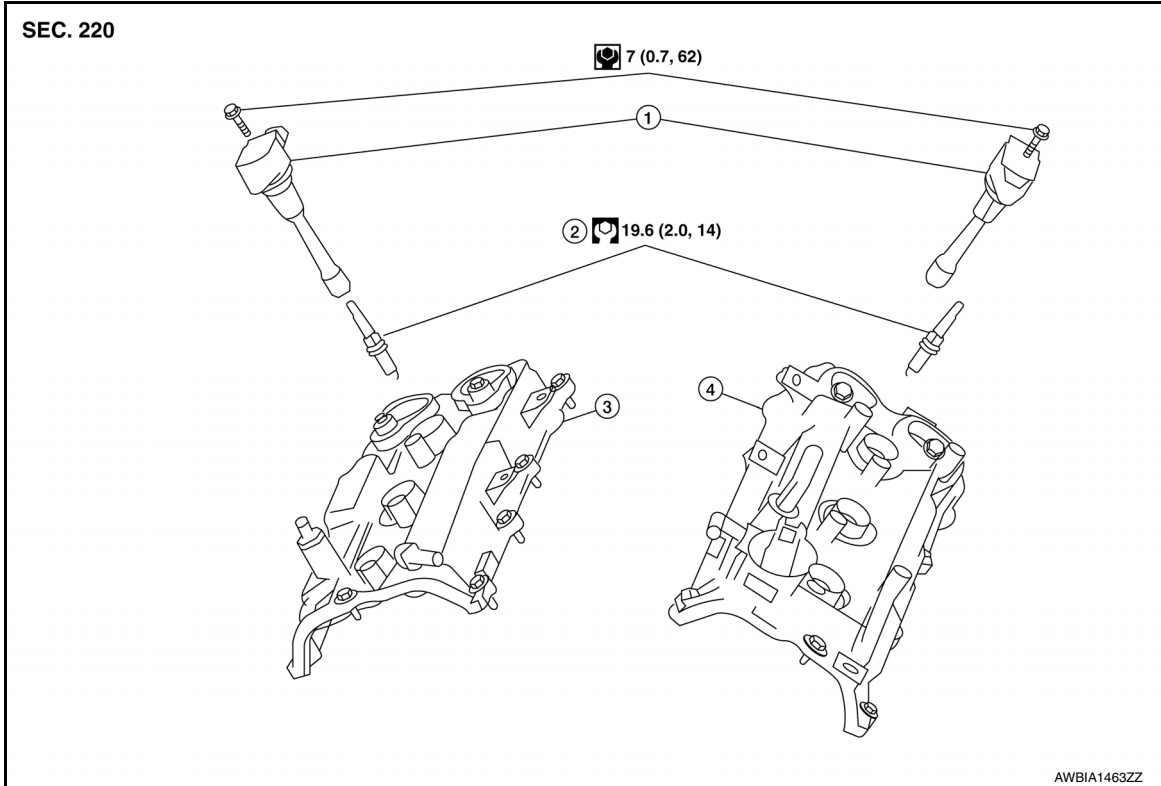

- 1. Ignition coil
- 2. Spark plug
- 3. Rocker cover (RH)
- 4. Rocker cover (LH)

Removal and Installation

INFOID:000000011933741

REMOVAL

1. Remove the ignition coil. Refer to [EM-45, "Removal and Installation \(LH\)"](#) and [EM-45, "Removal and Installation \(RH\)"](#).
2. Remove the spark plug with the Tool.

Tool number : (J-48891)

(a): : 14 mm (0.55 in)

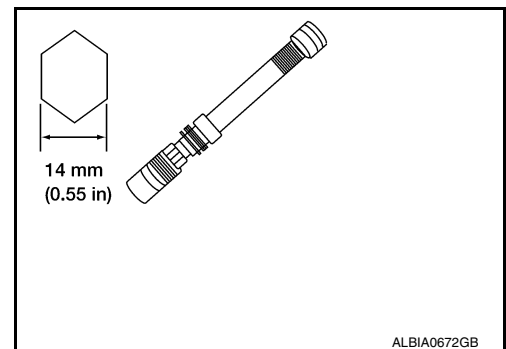

INSPECTION AFTER REMOVAL

SPARK PLUG

< PERIODIC MAINTENANCE >

- Do not use a wire brush for cleaning the spark plugs.

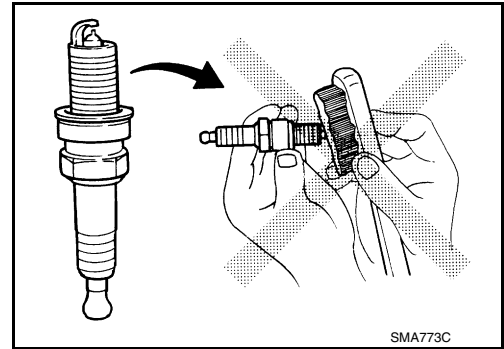

- If plug is covered with carbon, a spark plug cleaner may be used.

Cleaner air pressure : less than 588 kPa (6 kg/cm², 85 psi)

Cleaning time : less than 20 seconds

- Checking and adjusting spark plug gap is not required between change intervals. Do not adjust the gap; replace the spark plug as necessary if out of specification.

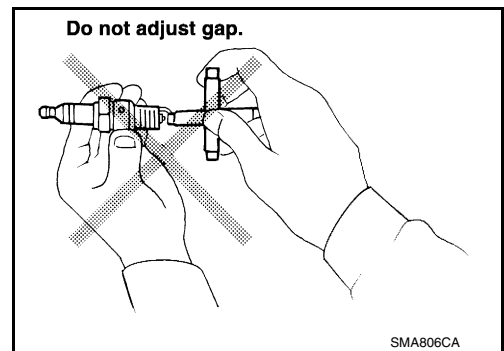

INSTALLATION

Installation is in the reverse order of removal.

Make	DENSO
Standard type*	FXE22HR11
Gap (nominal)	1.1 mm (0.043 in)

*: Always check with the Parts Department for the latest parts information.

A
EM
C
D
E
F
G
H
I
J
K
L
M
N
O
P

DRIVE BELTS

< PERIODIC MAINTENANCE >

DRIVE BELTS

Exploded View

INFOID:000000012219137

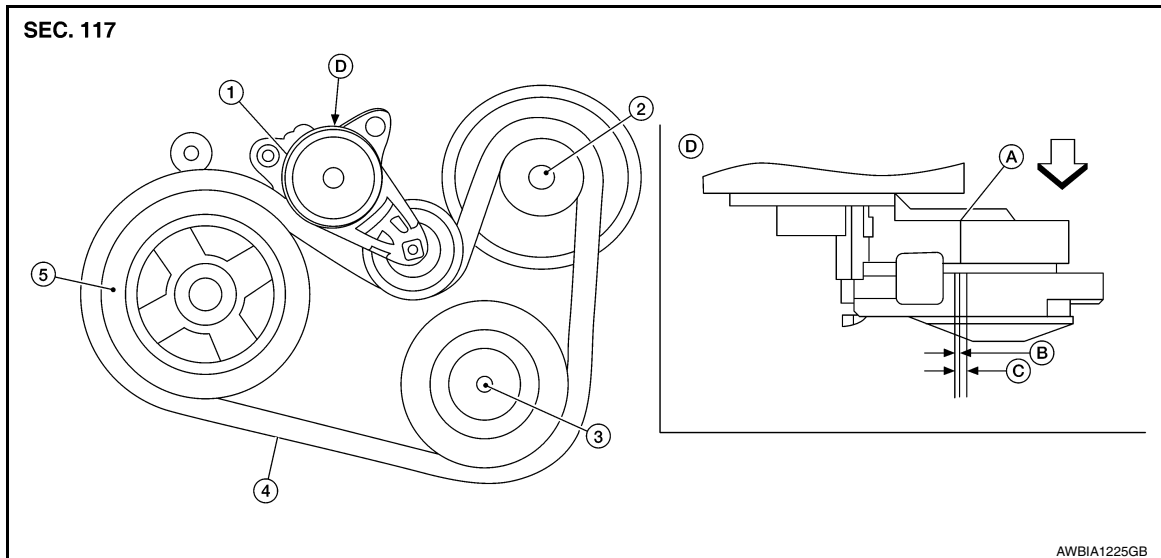

- | | | |
|---|-----------------------|-------------------|
| 1. Drive belt auto-tensioner | 2. Generator | 3. A/C compressor |
| 4. Drive belt | 5. Crankshaft pulley | A. Indicator |
| B. Range when new drive belt is installed | C. Possible use range | D. View D |
- ⇐ Engine front

Checking Drive Belt

INFOID:000000012219138

WARNING:

Inspect and check the drive belt with the engine off.

1. Visually check entire drive belt for wear, damage or cracks.
2. Check that the drive belt auto-tensioner indicator is within the possible use range.

NOTE:

- When new drive belt is installed, the drive belt auto-tensioner indicator should be within the new drive belt range.
 - Check the drive belt auto-tensioner indicator when the engine is cold.
3. If the drive belt auto-tensioner indicator is out of the possible use range or drive belt is damaged, replace drive belt.

Tension Adjustment

INFOID:000000011933743

- Drive belt tension is not manually adjustable, it is automatically adjusted by the drive belt auto-tensioner.

Removal and Installation

INFOID:000000012219139

REMOVAL

1. Remove the front wheel and tire (RH) using power tool. Refer to [MA-37, "WHEELS : Adjustment"](#).
2. Remove the fender protector side cover (RH). Refer to [EXT-28, "Exploded View"](#).

DRIVE BELTS

< PERIODIC MAINTENANCE >

3. While securely holding the hexagonal part in pulley center of drive belt auto-tensioner, move in the direction of arrow (loosening direction of drive belt auto-tensioner) using suitable tool.

WARNING:

Avoid placing hand in a location where pinching may occur if the holding tool accidentally comes off.

CAUTION:

Do not loosen the drive belt auto-tensioner pulley bolt. (Do not turn it counterclockwise. If turned counterclockwise, the complete drive belt auto-tensioner must be replaced as a unit, including pulley.)

4. Insert a rod approximately 6 mm (0.24 in) in diameter through the rear of drive belt auto-tensioner into retaining boss to lock drive belt auto-tensioner pulley.

NOTE:

Leave drive belt auto-tensioner pulley arm locked until drive belt is installed.

5. Remove drive belt from crankshaft pulley and then remove it from the other pulleys.

INSTALLATION

1. Install the drive belt onto all of the pulleys.

CAUTION:

Confirm belt is completely set on the pulleys.

2. Release drive belt auto-tensioner, and apply tension to drive belt.

WARNING:

Avoid placing hand in a location where pinching may occur if the holding tool accidentally comes off.

CAUTION:

Do not loosen the drive belt auto-tensioner pulley bolt. (Don't turn it counterclockwise. If turned counterclockwise, the complete drive belt auto-tensioner must be replaced as a unit, including pulley.)

3. Turn crankshaft pulley clockwise several times to equalize tension between each pulley.
4. Confirm drive belt auto-tensioner indicator is within the possible use range. Refer to [EM-16, "Checking Drive Belt"](#).
5. Install the fender protector side cover (RH). Refer to [EXT-28, "Exploded View"](#).
6. Install the front wheel and tire (RH). Refer to [MA-37, "WHEELS : Adjustment"](#).

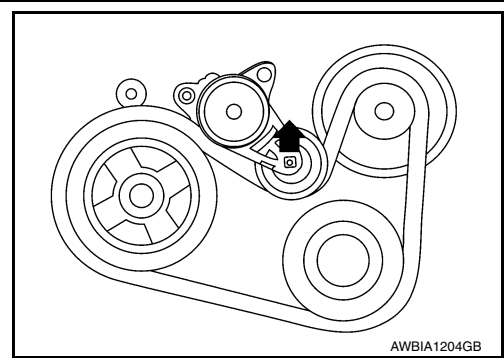

A

EM

C

D

E

F

G

H

I

J

K

L

M

N

O

P

DRIVE BELTS

< PERIODIC MAINTENANCE >

Removal and Installation of Drive Belt Auto-tensioner

INFOID:000000012219140

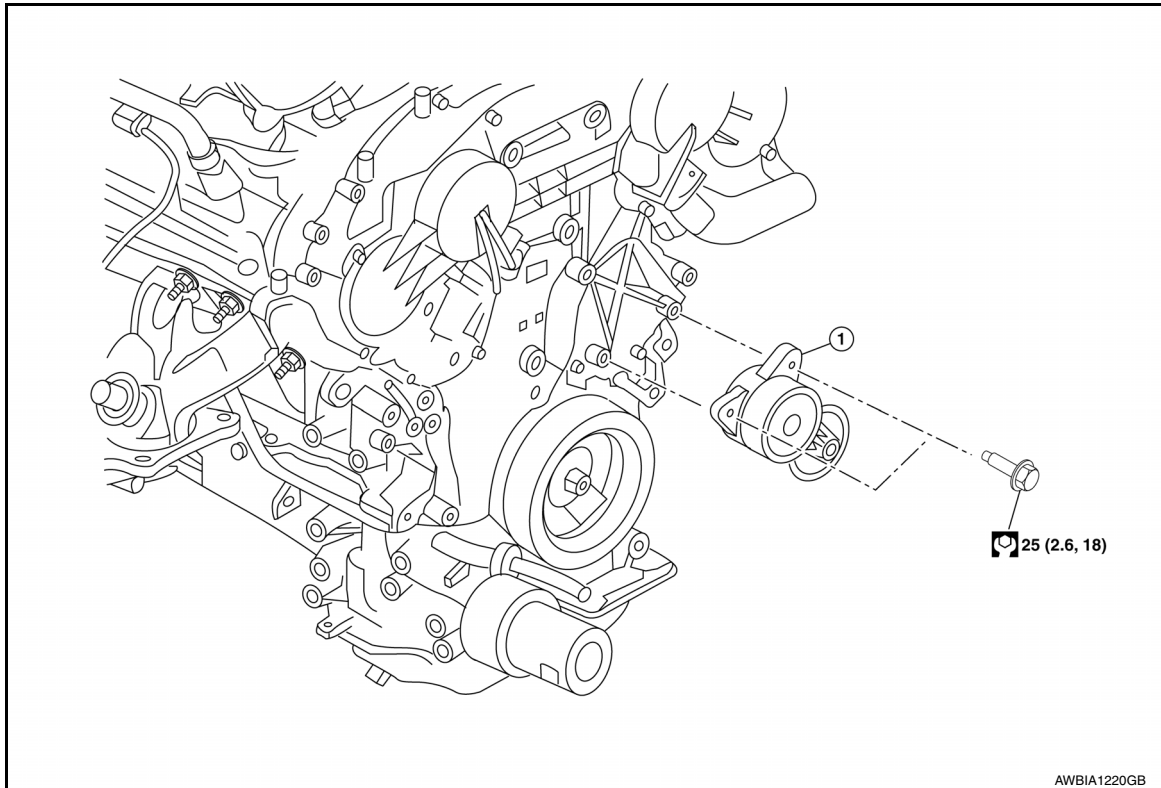

1. Drive belt auto-tensioner

REMOVAL

CAUTION:

The complete drive belt auto-tensioner must be replaced as a unit, including the pulley.

1. Remove the drive belt. Refer to [EM-16, "Removal and Installation"](#).
2. Remove the drive belt auto-tensioner.

CAUTION:

Do not loosen the drive belt auto-tensioner pulley bolt. (Do not turn it counterclockwise. If turned counterclockwise, the complete drive belt auto-tensioner must be replaced as a unit, including pulley).

INSTALLATION

Installation is in the reverse order of removal.

CAUTION:

- If there is damage greater than peeled paint, replace drive belt auto-tensioner unit.
- Do not swap the pulley between the new and old drive belt auto-tensioner units.
- The complete drive belt auto-tensioner must be replaced as a unit, including the pulley.

AIR CLEANER FILTER

< PERIODIC MAINTENANCE >

AIR CLEANER FILTER

Removal and Installation

INFOID:000000011933746

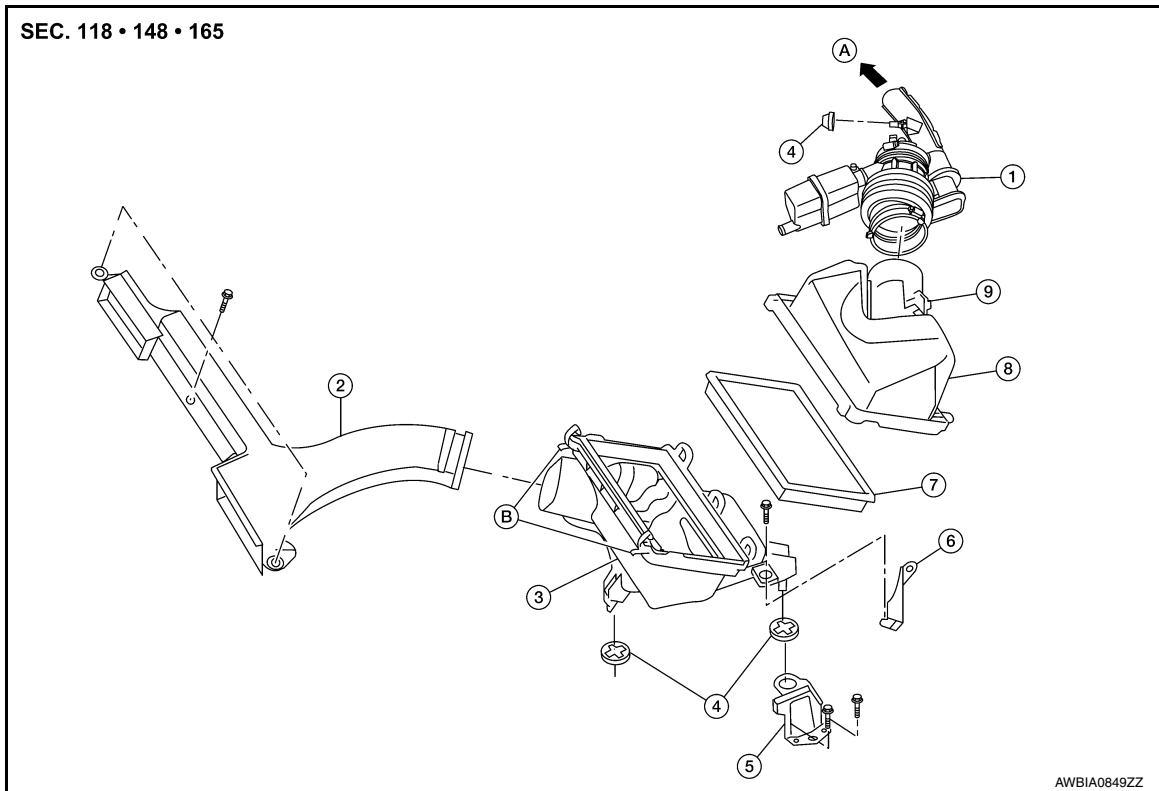

- | | | |
|--|--------------------------------------|-----------------------------|
| 1. Air duct hose and resonator assembly | 2. Front air duct | 3. Air cleaner case (lower) |
| 4. Grommets | 5. Air cleaner case mounting bracket | 6. Bracket |
| 7. Air cleaner filter | 8. Air cleaner case (upper) | 9. Mass air flow sensor |
| A. To electric throttle control actuator | B. Air cleaner case side clips | |

CHANGING THE AIR CLEANER FILTER

NOTE:

It is not necessary to remove the front air duct to replace the air cleaner filter.

1. Unhook the air cleaner case side clips.
2. Remove the air cleaner filter.
3. Install a new air cleaner filter.
4. Lock the air cleaner case side clips.

CAMSHAFT VALVE CLEARANCE

< PERIODIC MAINTENANCE >

CAMSHAFT VALVE CLEARANCE

Valve Clearance

INFOID:000000011933747

CHECKING

NOTE:

- Perform inspection as follows after removal, installation or replacement of camshaft or valve related parts, or if there are unusual engine conditions regarding valve clearance.
 - Check valve clearance while engine is cold and not running.
1. Remove the front air duct with air cleaner case, collectors, hoses, wires, harnesses, and connectors. Refer to [EM-26. "Removal and Installation"](#).
 2. Remove the intake manifold collectors. Refer to [EM-27. "Removal and Installation"](#).
 3. Remove the ignition coils and spark plugs. Refer to [EM-45. "Exploded View"](#).
 4. Remove the rocker covers. Refer to [EM-51. "Exploded View"](#).
 5. Set No.1 cylinder at TDC on its compression stroke.

⇐ : Engine front

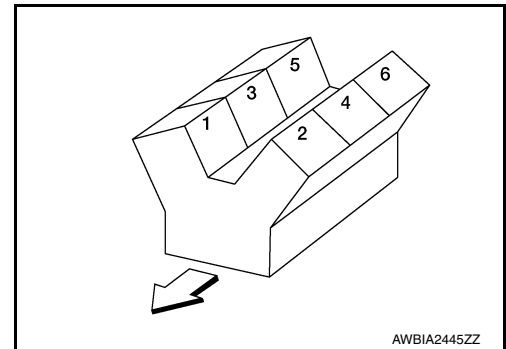

- a. Align pointer with TDC mark (A) on crankshaft pulley.

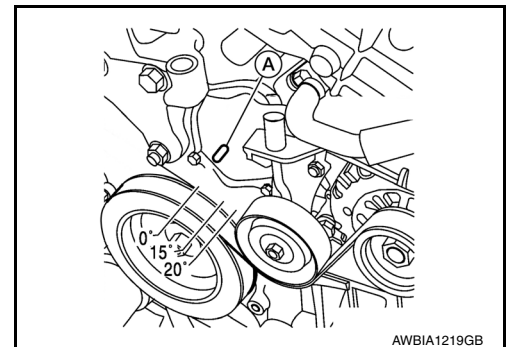

- b. Check that the valve lifters on No.1 cylinder, bank 1 (A) are loose and valve lifters on No.4 are tight. If not, turn the crankshaft one full revolution (360°) and align as shown.

⇐ : Engine front

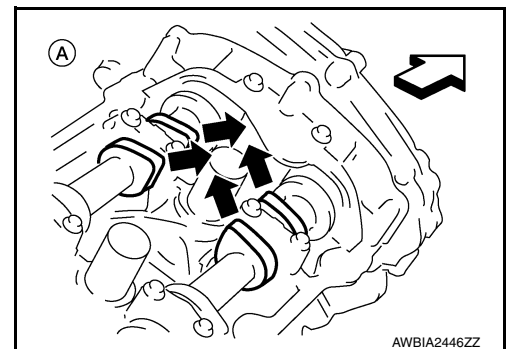

CAMSHAFT VALVE CLEARANCE

< PERIODIC MAINTENANCE >

6. Check only the valves as shown.

Crank Position	Valve No. 1	Valve No. 2	Valve No. 3	Valve No. 6
No. 1 TDC	Intake	Exhaust	Exhaust	Intake

- (A). : Bank 1 cylinder head
- (B). : Bank 2 cylinder head
- (C). : Bank 2 exhaust camshaft
- (D). : Bank 2 intake camshaft
- (E). : Bank 1 intake camshaft
- (F). : Bank 1 exhaust camshaft
- ← : Engine front

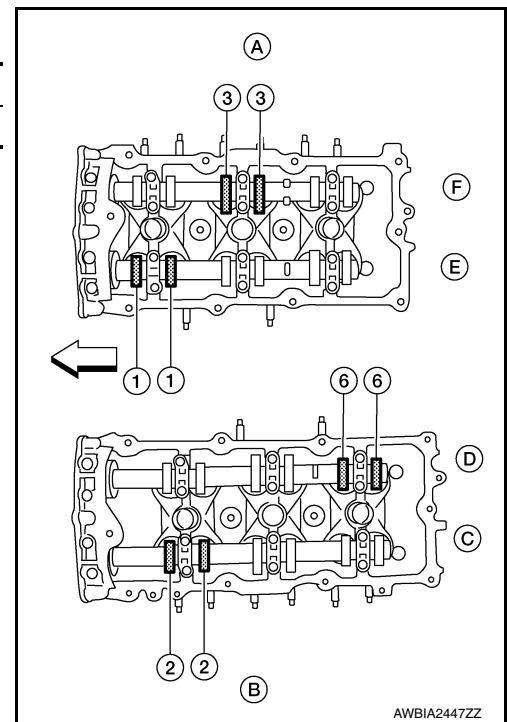

a. Using a feeler gauge, measure the clearance between the valve lifter and camshaft.

Valve clearance : Refer to [EM-139](#),
"General Specification".

b. Record any valve clearance measurements which are out of specification. They will be used later to determine the required replacement lifter size.

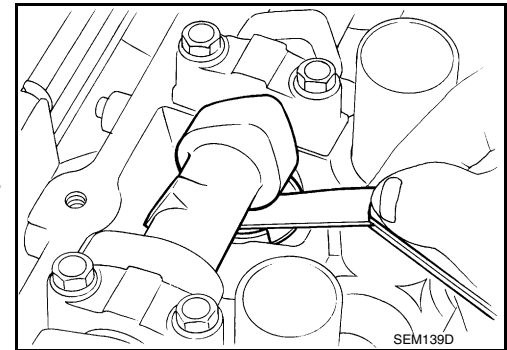

- (A). : Camshaft
- (B). : Valve lifter
- (C). : Suitable tool

7. Turn crankshaft 240°.

8. Set No.3 cylinder at TDC on its compression stroke.

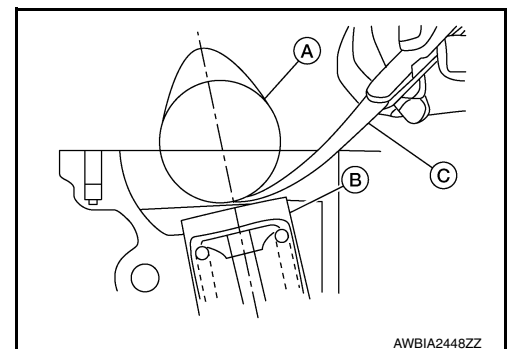

CAMSHAFT VALVE CLEARANCE

< PERIODIC MAINTENANCE >

9. Check only those valves as shown.

Crank Position	Valve No. 2	Valve No. 3	Valve No. 4	Valve No. 5
No. 3 TDC	Intake	Intake	Exhaust	Exhaust

- (A). : Bank 1 cylinder head
- (B). : Bank 2 cylinder head
- (C). : Bank 2 exhaust camshaft
- (D). : Bank 2 intake camshaft
- (E). : Bank 1 intake camshaft
- (F). : Bank 1 exhaust camshaft
- ⇐ : Engine front

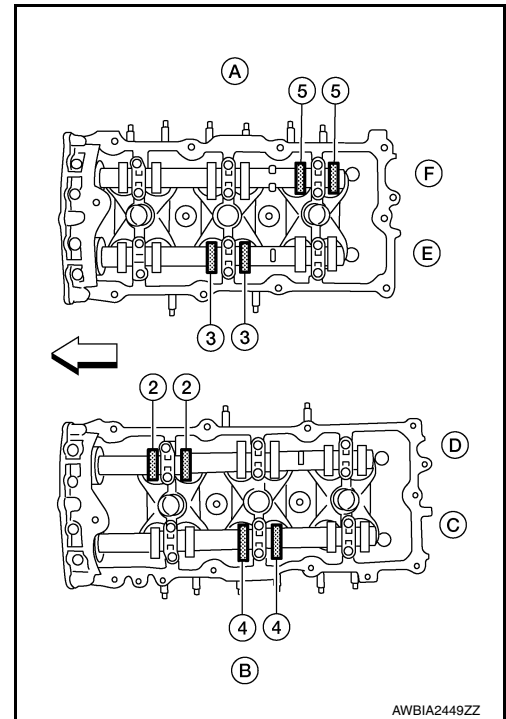

- 10. Turn the crankshaft 240° and align as above.
- 11. Set No.5 cylinder at TDC on its compression stroke.
- 12. Check only those valves as shown.

Crank Position	Valve No. 1	Valve No. 4	Valve No. 5	Valve No. 6
No. 5 TDC	Exhaust	Intake	Intake	Exhaust

- (A). : Bank 1 cylinder head
- (B). : Bank 2 cylinder head
- (C). : Bank 2 exhaust camshaft
- (D). : Bank 2 intake camshaft
- (E). : Bank 1 intake camshaft
- (F). : Bank 1 exhaust camshaft
- ⇐ : Engine front

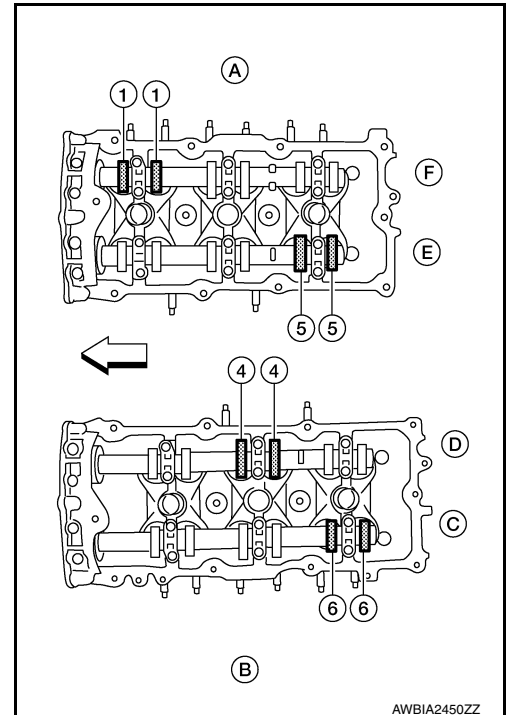

- 13. Perform adjustment if the measured values are out of the specification range.
- 14. Installation of components is in the reverse order of removal.

VALVE ADJUSTING

CAUTION:

Adjust valve clearance while engine is cold.

NOTE:

- Perform adjustment by selecting the correct head thickness of the valve lifter (adjusting shims are not used).

CAMSHAFT VALVE CLEARANCE

< PERIODIC MAINTENANCE >

- The specified valve lifter thickness dimension is measured at room temperature.
- Use specifications for hot engine for hot engine condition to confirm valve clearances.

1. Remove the camshaft.
2. Remove the valve lifter that was measured as being outside the standard specifications.
3. Measure the center thickness of the removed lifter with suitable tool (A) as shown.

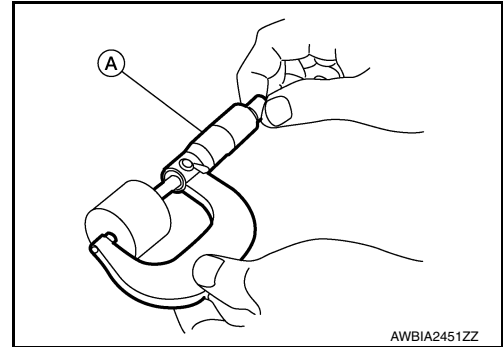

4. Use the equation below to calculate the replacement valve lifter thickness.

Valve lifter thickness calculation: $(C_1 - C_2) + t_1 = t$

C₁ = measured valve clearance

C₂ = standard valve clearance

t₁ = thickness of the removed lifter

t = thickness of the replacement lifter

- a. The thickness of the new valve lifter can be identified by the stamp mark (A) on the reverse side (inside the lifter).

NOTE:

Available thicknesses of the valve lifters (B) are: 3.00 - 3.50 mm (0.1181 - 0.1378 in), in 0.02 mm (0.0008 in) increments. Refer to [EM-140, "Camshaft"](#).

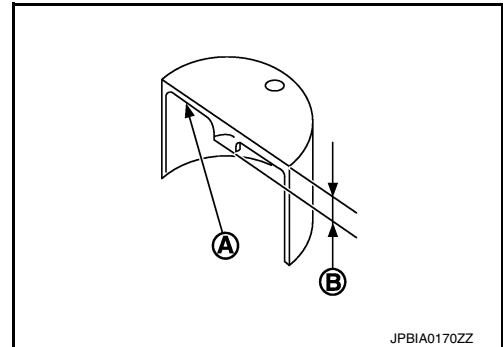

5. Install the selected replacement valve lifter.
6. Install the camshaft.
7. Rotate the crankshaft a few turns by hand.
8. Confirm that the valve clearances are within specification.
9. After the engine has been run to full operating temperature, confirm that the valve clearances are within specification.

Standard Valve Clearance	Cold ¹ (reference data)	Hot ² (reference data)
Intake	0.26 - 0.34 mm (0.010 - 0.013 in)	0.304 - 0.416 mm (0.012 - 0.016 in)
Exhaust	0.29 - 0.37 mm (0.011 - 0.015 in)	0.308 - 0.432 mm (0.012 - 0.017 in)

¹: Approximately 20°C (68°F)

²: Approximately 80°C (176°F)

COMPRESSION PRESSURE

< PERIODIC MAINTENANCE >

COMPRESSION PRESSURE

On-Vehicle Service

INFOID:000000011933748

CHECKING COMPRESSION PRESSURE

1. Run the engine until it reaches normal operating temperature.
2. Turn the ignition switch to OFF.
3. Release fuel pressure. Refer to [FL-4, "Inspection"](#).
4. Remove all six spark plugs.
Refer to [EM-14, "Removal and Installation"](#).
5. Attach a compression tester to No. 1 cylinder.

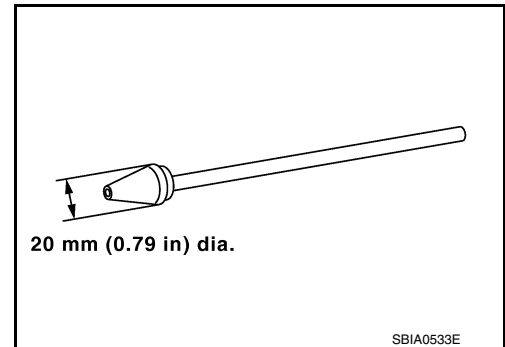

6. Depress accelerator pedal fully to keep the electric throttle control actuator butterfly-valve wide open to maximize air intake flow.
7. Crank the engine and record the highest gauge indication.
CAUTION:
Always use a fully charged battery to obtain specified engine speed.
8. Repeat the test for each cylinder (steps 5 - 7).

Unit: kPa (kg/cm², psi) /rpm

Standard	Minimum	Differential limit between cylinders
1,275 (13.0, 185) / 300	981 (10.0, 142) / 300	98 (1.0, 14) / 300

- If the engine speed is out of the specified range, check the battery and recharge as necessary. Check the engine speed again with the battery properly charged.
 - If some cylinders have low compression pressure, pour a small amount of engine oil into the spark plug hole of the cylinder to recheck it for compression.
 - If the added engine oil improves the compression, piston rings may be worn out or damaged. Check the piston rings and replace if necessary.
 - If the compression pressure remains at low level despite the addition of engine oil, the valves may be malfunctioning. Check the valves for damage. Replace the valve or valve seat accordingly.
 - If two adjacent cylinders have respectively low compression pressure and their compression remains low, even after the addition of engine oil, cylinder head gaskets may be leaking, or a valve in adjacent cylinders may be damaged. Inspect and repair as required.
 - If the compression pressure is below the minimum value, check the valve clearances and parts associated with the combustion chamber (valve, valve seat, piston, piston ring, cylinder bore, cylinder head, cylinder head gasket). After the checking, measure the compression pressure again.
9. Installation of the remaining components is in the reverse order of removal.

ENGINE ROOM COVER

< REMOVAL AND INSTALLATION >

REMOVAL AND INSTALLATION

ENGINE ROOM COVER

Exploded View

INFOID:0000000012504438

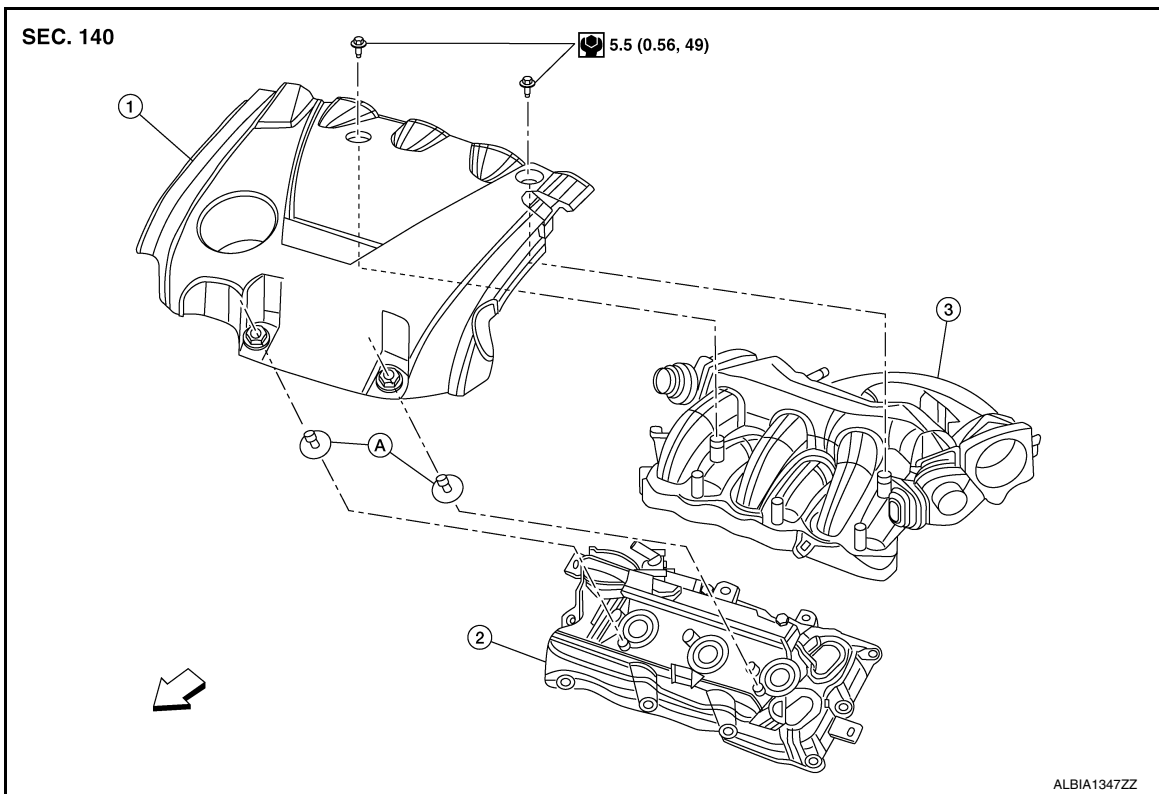

1. Engine room cover 2. Front rocker cover 3. Intake manifold
A. Engine room locking tabs

Removal and Installation

INFOID:0000000011933749

REMOVAL

CAUTION:

Do not damage or scratch engine room cover when installing or removing.

1. Remove the engine room cover bolts.
2. Release the engine room locking tabs, then remove the engine room cover.

INSTALLATION

Installation is in the reverse order of removal.

A
EM
C
D
E
F
G
H
I
J
K
L
M
N
O
P

AIR CLEANER AND AIR DUCT

< REMOVAL AND INSTALLATION >

AIR CLEANER AND AIR DUCT

Removal and Installation

INFOID:000000011933750

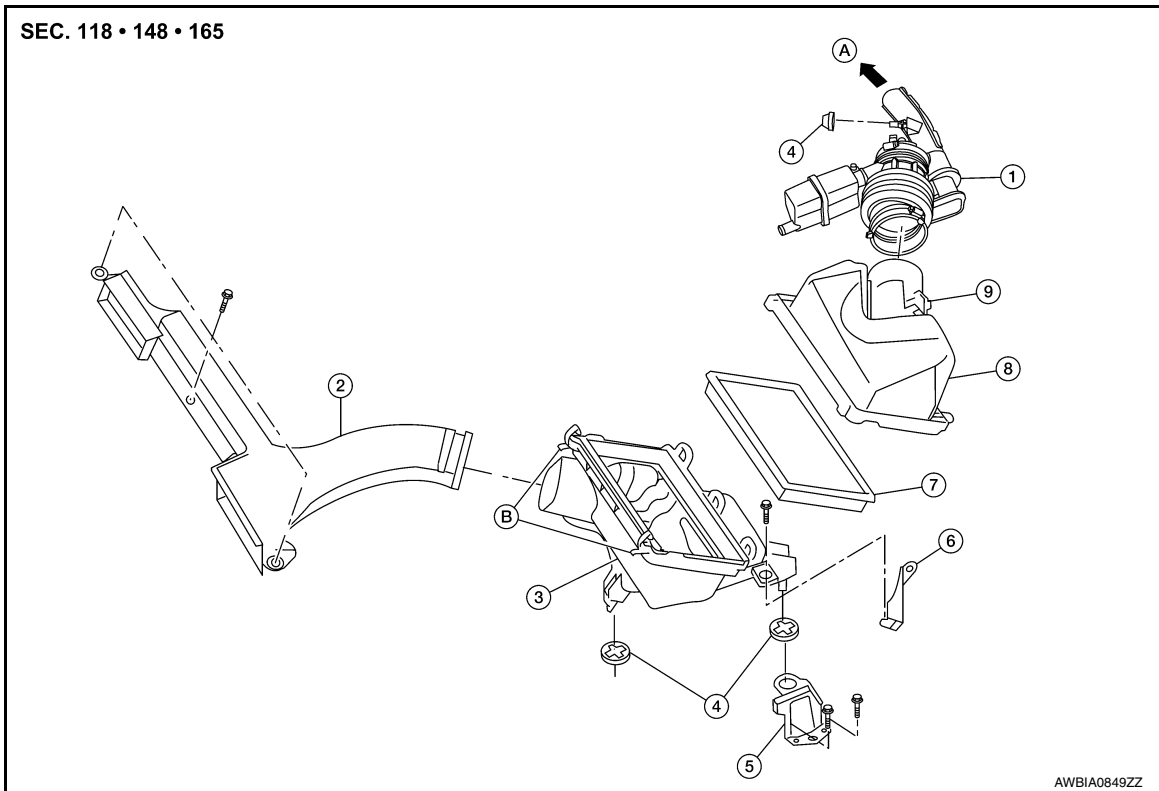

- | | | |
|--|--------------------------------------|-----------------------------|
| 1. Air duct hose and resonator assembly | 2. Front air duct | 3. Air cleaner case (lower) |
| 4. Grommets | 5. Air cleaner case mounting bracket | 6. Bracket |
| 7. Air cleaner filter | 8. Air cleaner case (upper) | 9. Mass air flow sensor |
| A. To electric throttle control actuator | B. Air cleaner case side clips | |

REMOVAL

1. Remove the front air duct.
2. Disconnect the breather hose.
3. Disconnect the hose from the upper intake manifold.
4. Disconnect the electric throttle control actuator tube clamp and the air duct hose and resonator tube clamp, then remove the air duct hose and resonator assembly.
5. Disconnect mass air flow/intake air temperature sensor electrical connector.
6. Remove mass air flow/intake air temperature from air cleaner case (upper).

CAUTION:

Handle sensor with care.

- Do not shock it.
- Do not disassemble it.
- Do not touch its sensor.

7. Disconnect transaxle breather hose.
8. Separate the harness connectors from the air cleaner case.
9. Remove air cleaner case assembly.

INSTALLATION

Installation is in the reverse order of removal.

INTAKE MANIFOLD COLLECTOR

< REMOVAL AND INSTALLATION >

INTAKE MANIFOLD COLLECTOR

Removal and Installation

INFOID:000000011933751

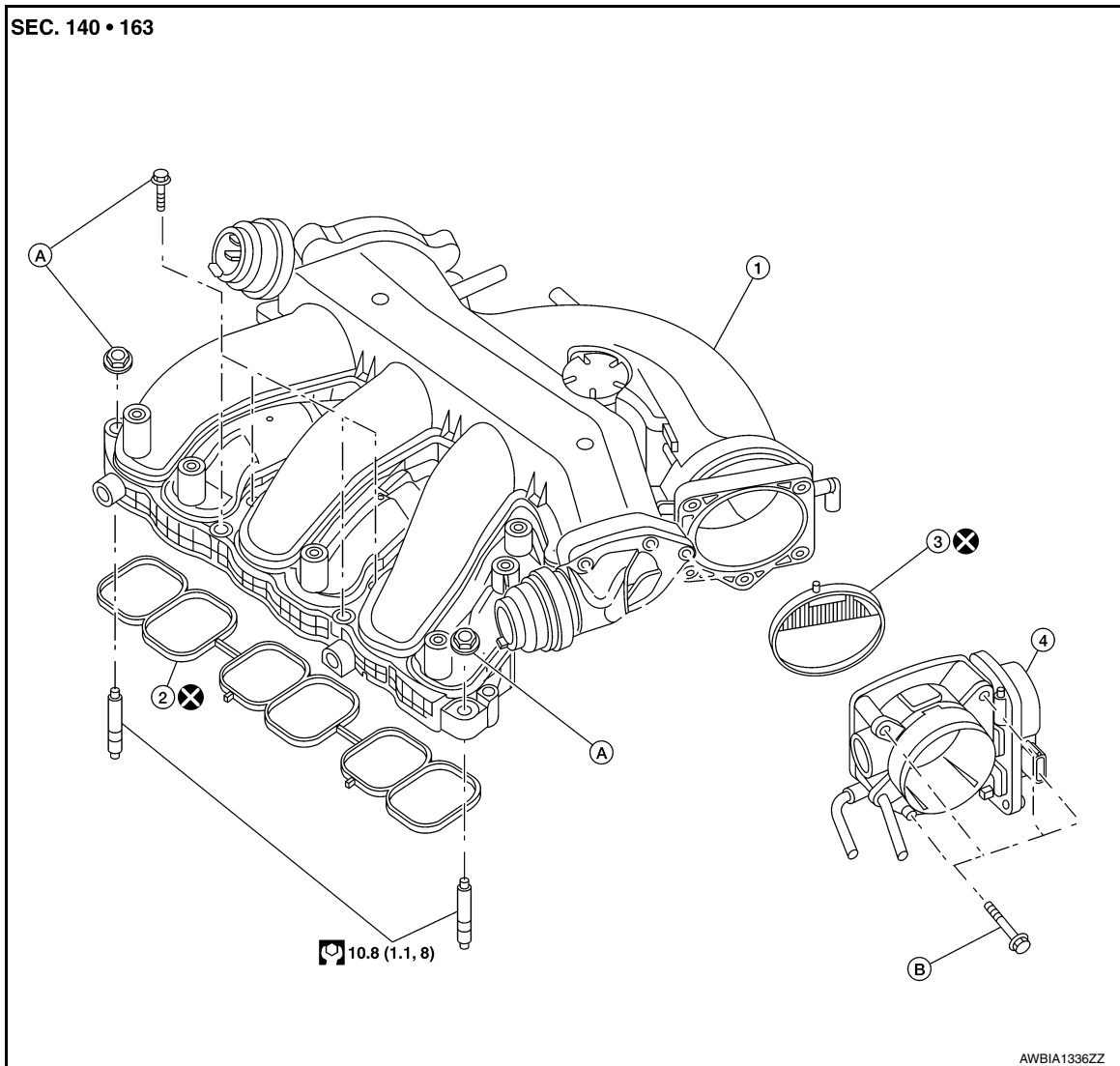

- | | | |
|---------------------------------------|-------------------------------------|--|
| 1. Intake manifold collector | 2. Intake manifold collector gasket | 3. Electric throttle control actuator gasket |
| 4. Electric throttle control actuator | A. Refer to INSTALLATION | B. Refer to INSTALLATION |

WARNING:

To avoid the danger of being scalded, do not drain the coolant when the engine is hot.

CAUTION:

Do not remove power valves.

CAUTION:

Cover any engine openings to avoid the entry of any foreign material.

NOTE:

When removing components such as hoses, tubes/lines, etc., cap or plug openings to prevent fluid from spilling.

REMOVAL

1. Remove the cowl top extension. Refer to [EXT-25, "Removal and Installation"](#).
2. Remove the engine room cover. Refer to [EM-25, "Removal and Installation"](#).
3. Remove front air duct and air duct hose and resonator assembly. Refer to [EM-26, "Removal and Installation"](#).

INTAKE MANIFOLD COLLECTOR

< REMOVAL AND INSTALLATION >

4. Remove the breather hose.
5. Remove the air duct hose.
6. Disconnect the throttle control actuator electrical connector, then remove the electric throttle control actuator bolts in the reverse order as shown. Remove the electric throttle control actuator and position aside.

CAUTION:

- Handle carefully to avoid any shock to the electric throttle control actuator.
- Do not disassemble.

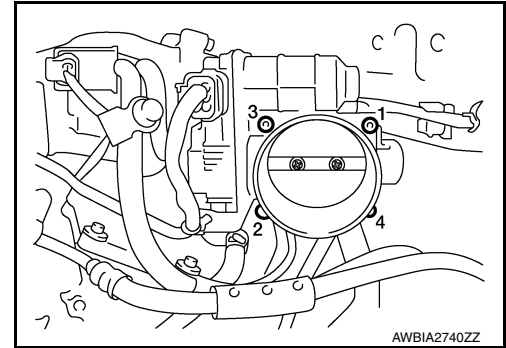

7. Disconnect the power brake booster vacuum hose and the PCV hose.
8. Disconnect the EVAP canister purge volume solenoid hoses, then remove the EVAP canister purge volume solenoid bracket bolts. Position the valves aside.
9. Remove the VIAS control solenoid bolts, disconnect the VIAS electrical connectors and position aside.
10. Loosen the intake manifold collector bolts in the reverse order as shown.

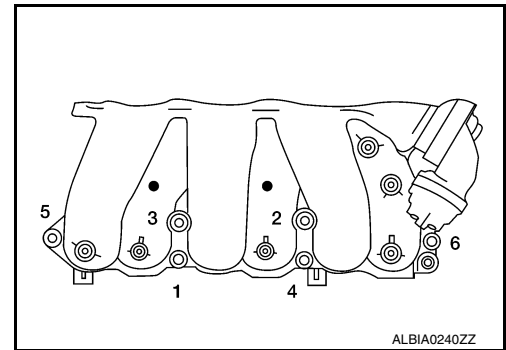

11. Remove the intake manifold collector, then remove and discard the intake manifold collector gasket.

INSTALLATION

CAUTION:

Do not reuse intake manifold collector gasket or electric throttle control actuator gasket.

Installation is in the reverse order of removal.

- Tighten intake manifold collector bolts in the order as shown.

**Intake manifold collector 11.0 N·m (1.1 kg-m, 8 ft-lb)
nuts and bolts**

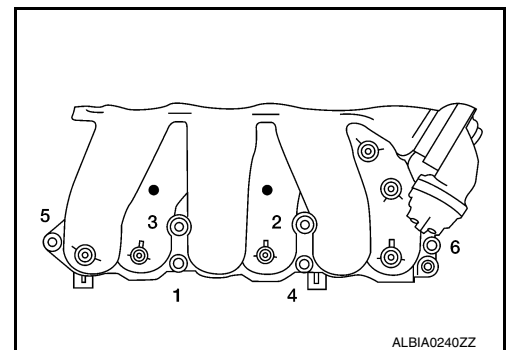

INTAKE MANIFOLD COLLECTOR

< REMOVAL AND INSTALLATION >

- Tighten electric throttle control actuator bolts in the order shown.

Electric throttle control actuator bolts **8.4 N·m (0.86 kg-m, 74 in-lb)**

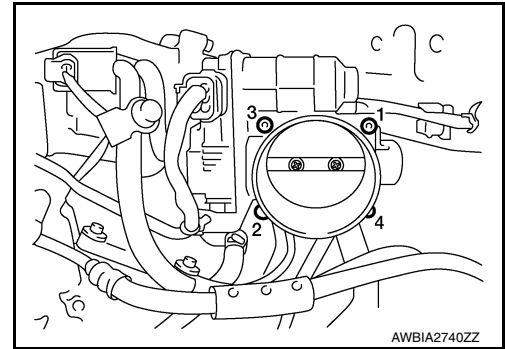

NOTE:

After installation, it is necessary to re-calibrate the electric throttle control actuator as follows:

1. Perform the "Throttle Valve Closed Position Learning" when harness connector of the electric throttle control actuator is disconnected. Refer to [EC-159, "Description"](#).
2. Perform the "Idle Air Volume Learning" when the electric throttle control actuator is replaced. Refer to [EC-160, "Description"](#).

A

EM

C

D

E

F

G

H

I

J

K

L

M

N

O

P

INTAKE MANIFOLD

< REMOVAL AND INSTALLATION >

INTAKE MANIFOLD

Exploded View

INFOID:000000012496331

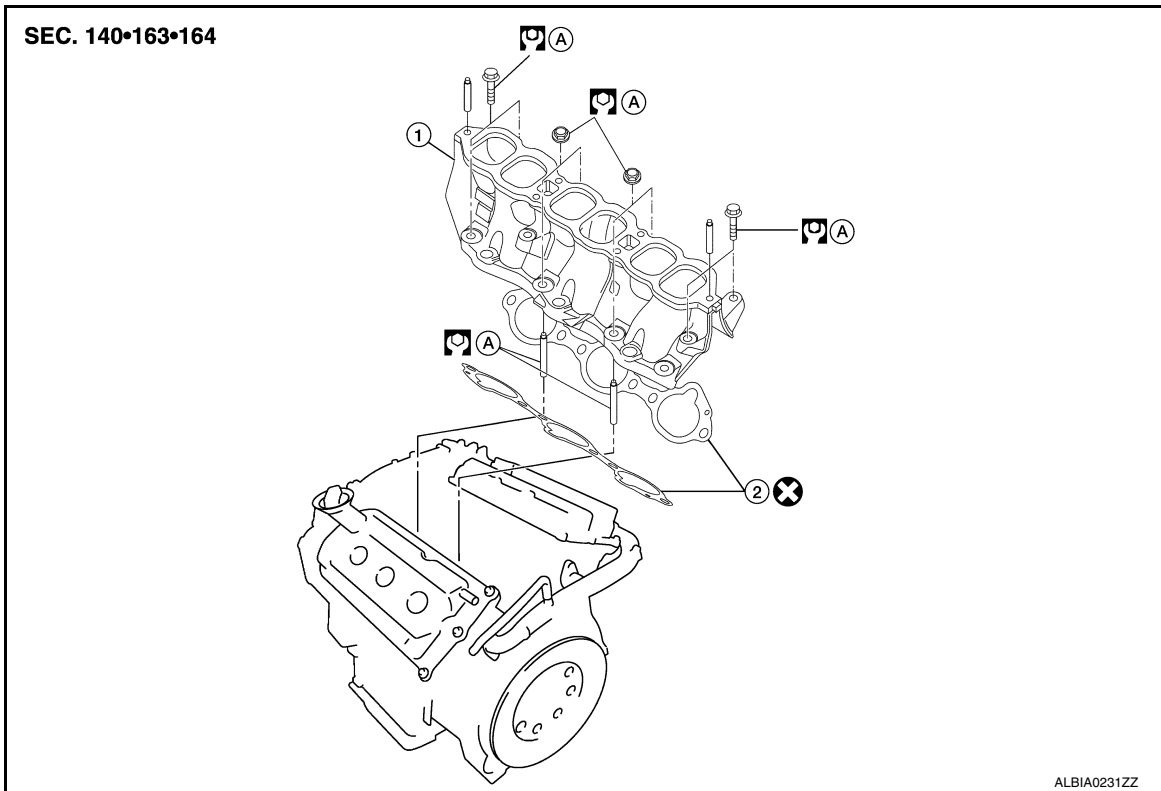

1. Intake manifold

2. Intake manifold gasket

A. Refer to INSTALLATION

Removal and Installation

INFOID:000000011933752

REMOVAL

WARNING:

To avoid the danger of being scalded, do not drain the coolant when the engine is hot.

NOTE:

When removing components such as hoses, tubes/lines, etc., cap or plug openings to prevent fluid from spilling.

1. Remove fuel injectors and fuel tube. Refer to [EM-46, "Removal and Installation"](#).
2. Remove the intake manifold and the intake manifold gaskets. Loosen nuts and bolts in reverse order as shown.

CAUTION:

Cover the engine openings to avoid the entry of foreign materials.

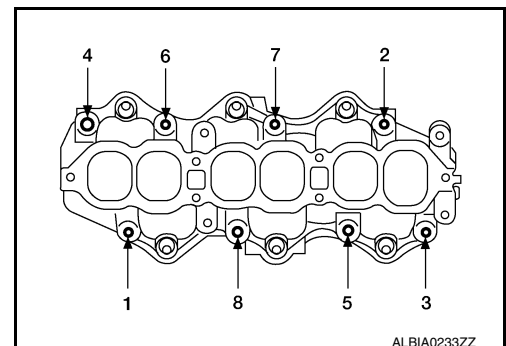

INSPECTION AFTER REMOVAL

Surface Distortion

INTAKE MANIFOLD

< REMOVAL AND INSTALLATION >

- Using straightedge and feeler gauge, inspect the surface distortion of the intake manifold.

Standard : 0.1 mm (0.004 in)

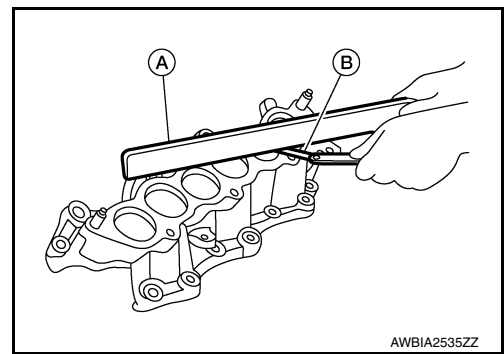

INSTALLATION

Installation is in the reverse order of removal. Follow the procedure below for specific tightening sequences and procedures.

CAUTION:

Do not reuse intake manifold gaskets.

- Install intake manifold nuts and bolts in two steps in the numerical order as shown.

Step 1 : 7.4 N·m (0.75 kg-m, 65 in-lb)

Step 2 : 25.5 N·m (2.6 kg-m, 19 ft-lb)

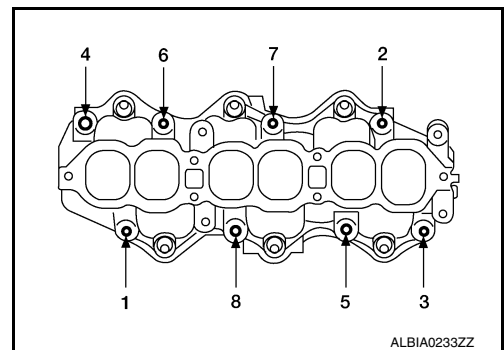

INSPECTION AFTER INSTALLATION

Make sure there are no fuel leaks at the connections as follows:

- Apply fuel pressure to fuel lines by turning ignition switch ON (with engine stopped). Then check for fuel leaks at connections.
- Start the engine and rev it up and check for fuel leaks at connections.

WARNING:

Do not touch engine immediately after stopping as engine is extremely hot.

NOTE:

Use mirrors for checking on connections out of the direct line of sight.

EXHAUST MANIFOLD AND THREE WAY CATALYST

< REMOVAL AND INSTALLATION >

EXHAUST MANIFOLD AND THREE WAY CATALYST

Exploded View

INFOID:000000011933753

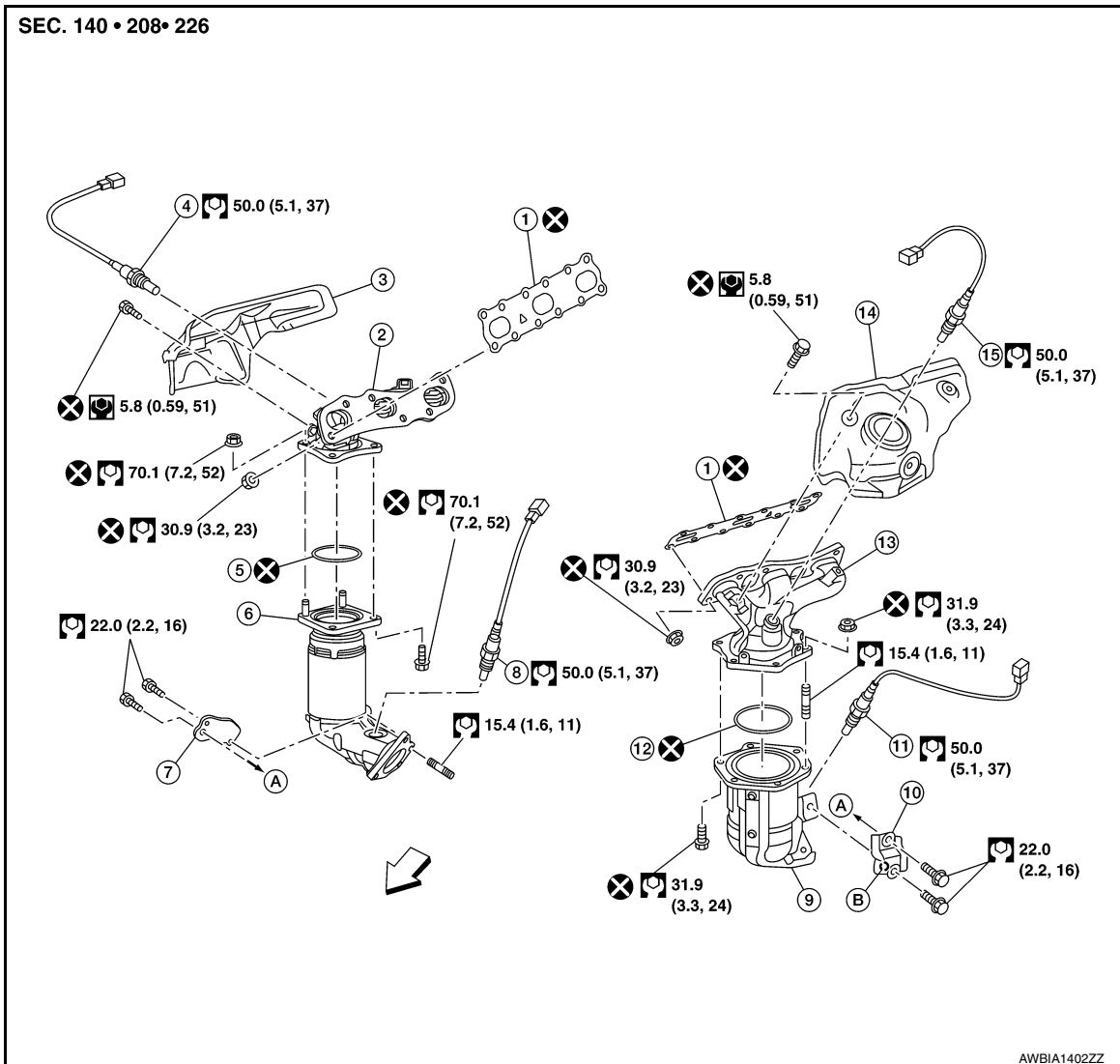

- | | | |
|---|---|--|
| 1. Gasket | 2. Exhaust manifold (bank 1) | 3. Exhaust manifold heat shield (bank 1) |
| 4. Air fuel ratio sensor 1 (bank 1) | 5. Ring gasket | 6. Three way catalyst (bank 1) |
| 7. Three way catalyst support (bank 1) | 8. Heated oxygen sensor 2 (bank 1) | 9. Three way catalyst (bank 2) |
| 10. Three way catalyst support (bank 2) | 11. Heated oxygen sensor 2 (bank 2) | 12. Ring gasket |
| 13. Exhaust manifold (bank 2) | 14. Exhaust manifold heat shield (bank 2) | 15. Air fuel ratio sensor 1 (bank 2) |
| A. To oil pan (upper) | B. Upper mark | ← Engine front |

Removal and Installation (bank 2)

INFOID:000000011933754

REMOVAL

WARNING:

- Perform the work when the exhaust system has completely cooled down.
- When removing the front and rear engine mounting through bolts and nuts, lift the engine up slightly for safety.

NOTE:

EXHAUST MANIFOLD AND THREE WAY CATALYST

< REMOVAL AND INSTALLATION >

When removing components such as hoses, tubes/lines, etc., cap or plug openings to prevent fluid from spilling.

1. Remove the radiator. Refer to [CO-14. "Removal and Installation"](#).
2. Remove the three way catalyst. Refer to [EM-36. "Removal and Installation \(bank 2\)"](#).
3. Loosen and remove the exhaust manifold nuts in the reverse order as shown.

↩ : Engine front

NOTE:

Number 7 and 8 are not applicable to removal.

4. Remove the exhaust manifold (bank 2) and gasket.

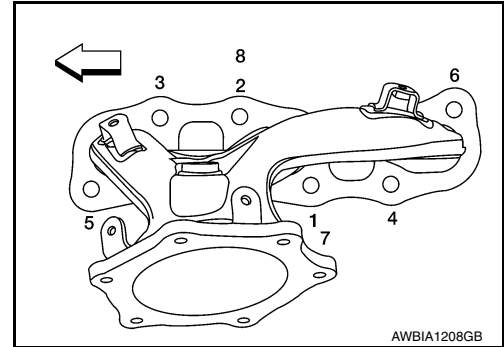

INSPECTION AFTER REMOVAL

Surface Distortion

- Use suitable tools (A/B) to check the flatness of the exhaust manifold mating surfaces.

Limit : 0.3 mm (0.012 in)

- Replace the exhaust manifold if the measurement exceeds specifications.

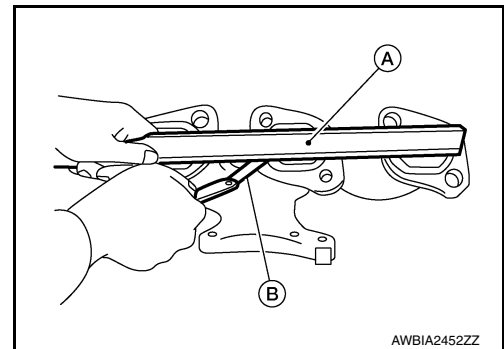

INSTALLATION

Installation is in the reverse order of removal.

1. Install the studs in the exhaust manifold (if removed), and tighten to specification.

Exhaust manifold studs : 15.4 N·m (1.6 kg-m, 11 ft-lb)

2. Install the exhaust manifold gasket in the direction shown.

CAUTION:

Do not reuse exhaust manifold gaskets.

- (A) : Bank 1
- (B) : Triangle press
- (C) : Bank 2
- ↩ : Engine front

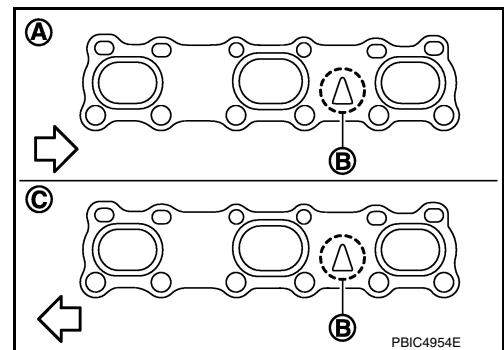

3. Install the exhaust manifold (bank 2) nuts and tighten to specification in the order shown.

↩ : Engine front

NOTE:

Number 7 and 8 are tightened a second time.

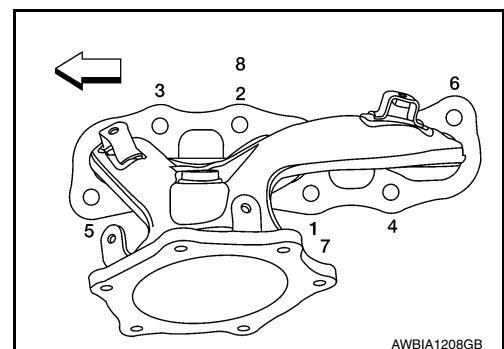

EXHAUST MANIFOLD AND THREE WAY CATALYST

< REMOVAL AND INSTALLATION >

CAUTION:

- Before installing a heated oxygen sensor 2 or air fuel ratio (A/F) sensor 1, clean the exhaust manifold threads using the oxygen sensor thread cleaner tool and apply anti-seize lubricant.

Oxygen sensor thread cleaner : (J-43897-18)

Oxygen sensor thread cleaner : (J-43897-12)

- Do not over-tighten the air fuel ratio (A/F) sensor 1 or heated oxygen sensors 2. Doing so may cause damage.

Tool numbers : KV10114400 (J-38365)

: KV991J0050 (J-44626)

Removal and Installation (bank 1)

INFOID:000000011933755

REMOVAL

WARNING:

- Perform the work when the exhaust and cooling system have completely cooled down.
- When removing the front and rear engine mounting through bolts and nuts, lift the engine up slightly for safety.

1. Remove the engine and transaxle assembly. Refer to [EM-107, "Removal and Installation"](#).
2. Remove the three way catalyst support (bank 1).
3. Remove rear engine mount bracket. Refer to [EM-107, "Removal and Installation"](#).
4. Remove heated oxygen sensor 2 (bank 1), air fuel ratio (A/F) sensor 1 (bank 1).
 - a. Remove harness connector from heated oxygen sensor 2 (bank 1) and air fuel ratio (A/F) sensor 1, and disconnect the harness from the bracket and middle clamp.
 - b. Remove both heated oxygen sensors 2 (bank 1) and air fuel ratio (A/F) sensors 1 using Tool.

Tool numbers : KV10114400 (J-38365)

: KV991J0050 (J-44626)

CAUTION:

- Be careful not to damage heated oxygen sensors 2 or air fuel ratio (A/F) sensors 1.
 - Discard any heated oxygen sensor 2 which has been dropped from a height of more than 0.5 m (19.7 in) onto a hard surface such as a concrete floor; replace with a new sensor.
5. Remove exhaust manifold heat shield (bank 1) and three way catalyst heat shields (bank 1) using power tool.
 6. Remove the three way catalyst (bank 1) by loosening the bolts first and then removing the nuts and through bolts.
 7. Loosen the exhaust manifold nuts in the reverse order as shown and remove the exhaust manifold (bank 1).

⇐ : Engine front

NOTE:

Number 7 and 8 are not applicable to removal.

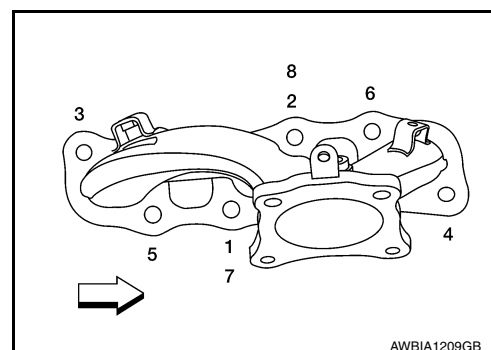

INSPECTION AFTER REMOVAL

Surface Distortion

EXHAUST MANIFOLD AND THREE WAY CATALYST

< REMOVAL AND INSTALLATION >

- Use suitable tools (A/B) to check the flatness of the exhaust manifold mating surfaces.

Limit : 0.3 mm (0.012 in)

- Replace the exhaust manifold if the measurement exceeds specifications.

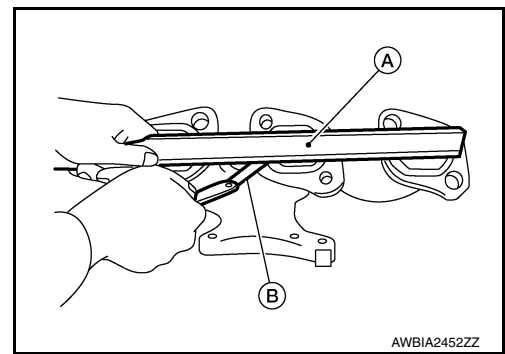

INSTALLATION

Installation is in the reverse order of removal.

CAUTION:

Do not reuse exhaust manifold gaskets.

- Install the exhaust manifold nuts in the order as shown (A).

← : Engine front

NOTE:

Number 7 and 8 are tightened a second time.

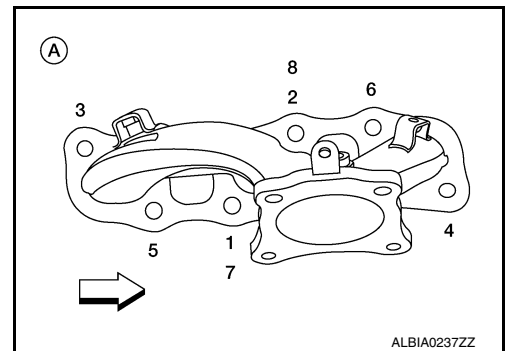

CAUTION:

- Before installing a heated oxygen sensor 2 or air fuel ratio (A/F) sensor 1, clean the exhaust manifold threads using the oxygen sensor thread cleaner tool, and apply anti-seize lubricant.

Tool numbers : J-43897-18

: J-43897-12

- Do not over-tighten the air fuel ratio (A/F) sensor 1 or heated oxygen sensors 2. Doing so may cause damage.

Tool numbers : KV10114400 (J-38365)

: KV991J0050 (J-44626)

THREE WAY CATALYST

< REMOVAL AND INSTALLATION >

THREE WAY CATALYST

Exploded View

INFOID:000000011933756

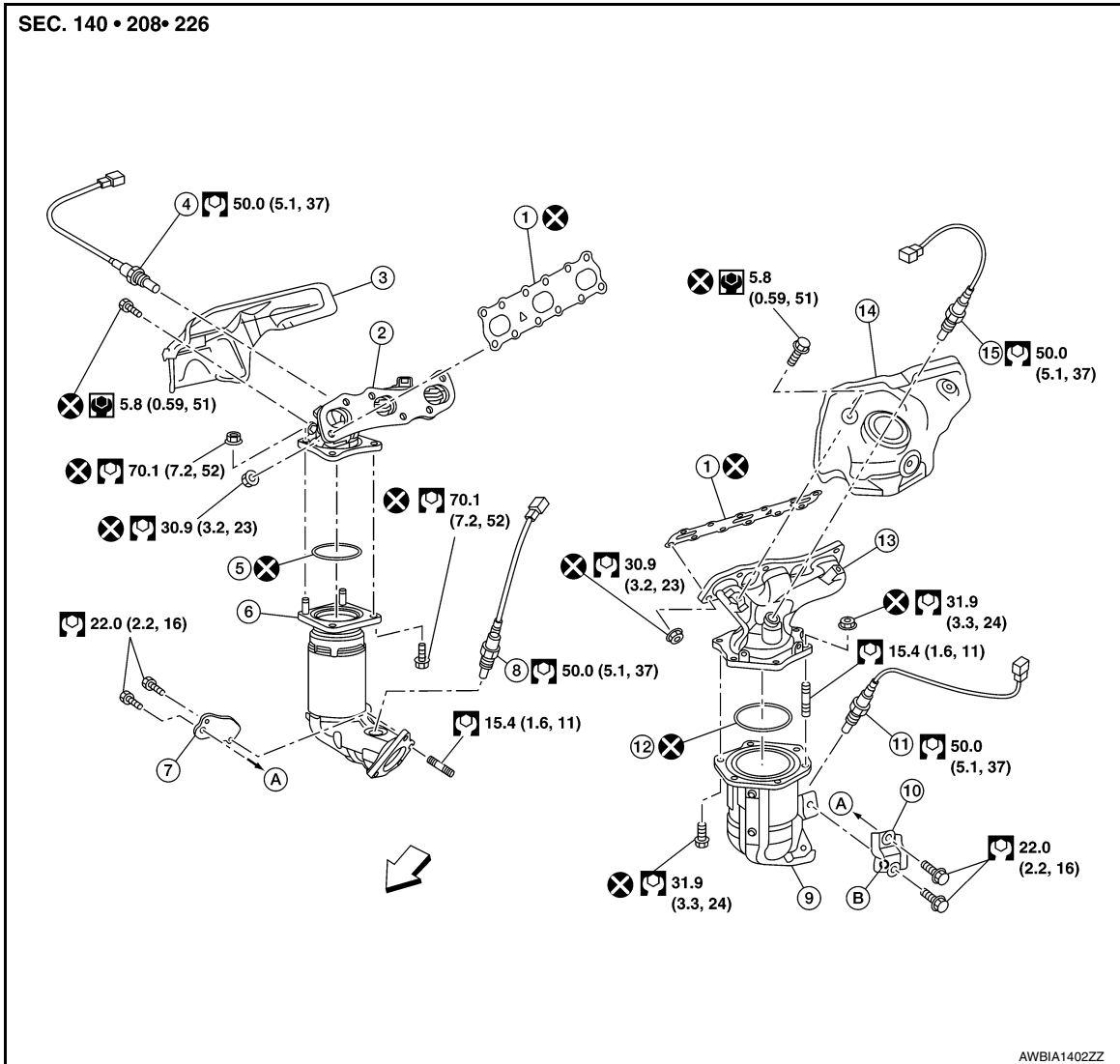

- | | | |
|---|---|--|
| 1. Gasket | 2. Exhaust manifold (bank 1) | 3. Exhaust manifold heat shield (bank 1) |
| 4. Air fuel ratio sensor 1 (bank 1) | 5. Ring gasket | 6. Three way catalyst (bank 1) |
| 7. Three way catalyst support (bank 1) | 8. Heated oxygen sensor 2 (bank 1) | 9. Three way catalyst (bank 2) |
| 10. Three way catalyst support (bank 2) | 11. Heated oxygen sensor 2 (bank 2) | 12. Ring gasket |
| 13. Exhaust manifold (bank 2) | 14. Exhaust manifold heat shield (bank 2) | 15. Air fuel ratio sensor 1 (bank 2) |
| A. To oil pan (upper) | B. Upper mark | ⇐ Engine front |

Removal and Installation (bank 2)

INFOID:000000011933757

REMOVAL

WARNING:

Perform the work when the exhaust system has completely cooled down.

NOTE:

When removing components such as hoses, tubes/lines, etc., cap or plug openings to prevent fluid from spilling.

1. Remove the radiator cooling fan assembly. Refer to [CO-16. "Removal and Installation"](#).

THREE WAY CATALYST

< REMOVAL AND INSTALLATION >

2. Remove hoodledge covers (LH/RH).
3. Remove radiator hose (upper). Refer to [CO-25, "Exploded View"](#).
4. Remove heater pipe. Refer to [CO-25, "Exploded View"](#).
5. Remove water bypass pipe. Refer to [CO-25, "Exploded View"](#).
6. Remove heater hose.
7. Remove engine under cover. Refer to [EXT-16, "Exploded View"](#).
8. Remove the front exhaust tube. Refer to [EX-5, "Exploded View"](#).
9. Remove the three way catalyst support (bank 2).
10. Disconnect harness connectors from heated oxygen sensor 2 (bank 2) and air fuel ratio (A/F) sensor 1 (bank 2).
11. Remove heated oxygen sensor 2 (bank 2) (if necessary), using suitable tool.

CAUTION:

- **Be careful not to damage heated oxygen sensor 2 (bank 2).**
 - **Discard any heated oxygen sensor 2 which has been dropped from a height of more than 0.5 m (19.7 in) onto a hard surface such as a concrete floor; replace with a new sensor.**
12. Remove exhaust manifold heat shield (bank 2).
 13. Remove the three way catalyst (bank 2) by loosening the bolts first and then removing the nuts and through bolts.
 14. Remove the three way catalyst (bank 2) heat shield (if necessary).

INSTALLATION

Installation is in the reverse order of removal.

CAUTION:

- **Before installing heated oxygen sensor 2 (bank 2), clean the exhaust manifold threads using the oxygen sensor thread cleaner tool and apply anti-seize lubricant.**

Oxygen sensor thread cleaner : (J-43897-18)

- **Do not over-tighten the heated oxygen sensor 2 (bank 2). Doing so may cause damage.**

NOTE:

After installation, it is necessary to re-calibrate the electric throttle control actuator as follows:

- Perform the "Throttle Valve Closed Position Learning" when harness connector of the ECM is disconnected. Refer to [EC-159, "Description"](#).
- Perform the "Accelerator Pedal Released Position Learning" when harness connector of the ECM is disconnected. Refer to [EC-158, "Description"](#).

Removal and Installation (bank 1)

INFOID:0000000011933758

REMOVAL

WARNING:

- **Perform the work when the exhaust system has completely cooled down.**
- **When removing the front and rear engine mounting through bolts and nuts, lift the engine up slightly for safety.**

NOTE:

When removing components such as hoses, tubes/lines, etc., cap or plug openings to prevent fluid from spilling.

1. Remove hoodledge covers (LH/RH).
2. Remove intake manifold collector. Refer to [EM-27, "Removal and Installation"](#).
3. Remove the front fender protector side cover. Refer to [EXT-28, "Exploded View"](#).
4. Remove drive shaft (RH). Refer to [FAX-20, "Removal and Installation \(RH\)"](#).
5. Remove the front exhaust tube. Refer to [EX-5, "Exploded View"](#).
6. Disconnect harness connectors from heated oxygen sensor 2 (bank 1) and air fuel ratio (A/F) sensor 1 (bank 1).
7. Remove heated oxygen sensor 2 (bank 1) (if necessary), using suitable tool.

CAUTION:

- **Be careful not to damage heated oxygen sensor 2 (bank 1).**

THREE WAY CATALYST

< REMOVAL AND INSTALLATION >

- **Discard any heated oxygen sensor 2 which has been dropped from a height of more than 0.5 m (19.7 in) onto a hard surface such as a concrete floor; replace with a new sensor.**
8. Remove exhaust manifold heat shield (bank 1).
 9. Remove the three way catalyst support (bank 1).
 10. Remove the three way catalyst (bank 1) by loosening the bolts first and then removing the nuts and through bolts.
 11. Remove the three way catalyst (bank 1) heat shield (if necessary).

INSTALLATION

Installation is in the reverse order of removal.

CAUTION:

- **Before installing heated oxygen sensor 2 (bank 1), clean the exhaust manifold threads using the oxygen sensor thread cleaner tool and apply anti-seize lubricant.**

Oxygen sensor thread cleaner : (J-43897-18)

- **Do not over-tighten the heated oxygen sensor 2 (bank 1). Doing so may cause damage.**

NOTE:

After installation, it is necessary to re-calibrate the electric throttle control actuator as follows:

- Perform the "Throttle Valve Closed Position Learning" when harness connector of the electric throttle control actuator is disconnected. Refer to [EC-159, "Description"](#).
- Inspect CVT fluid level. Refer to [TM-184, "Inspection"](#).

OIL PAN AND OIL STRAINER

< REMOVAL AND INSTALLATION >

OIL PAN AND OIL STRAINER

Exploded View

INFOID:000000012229526

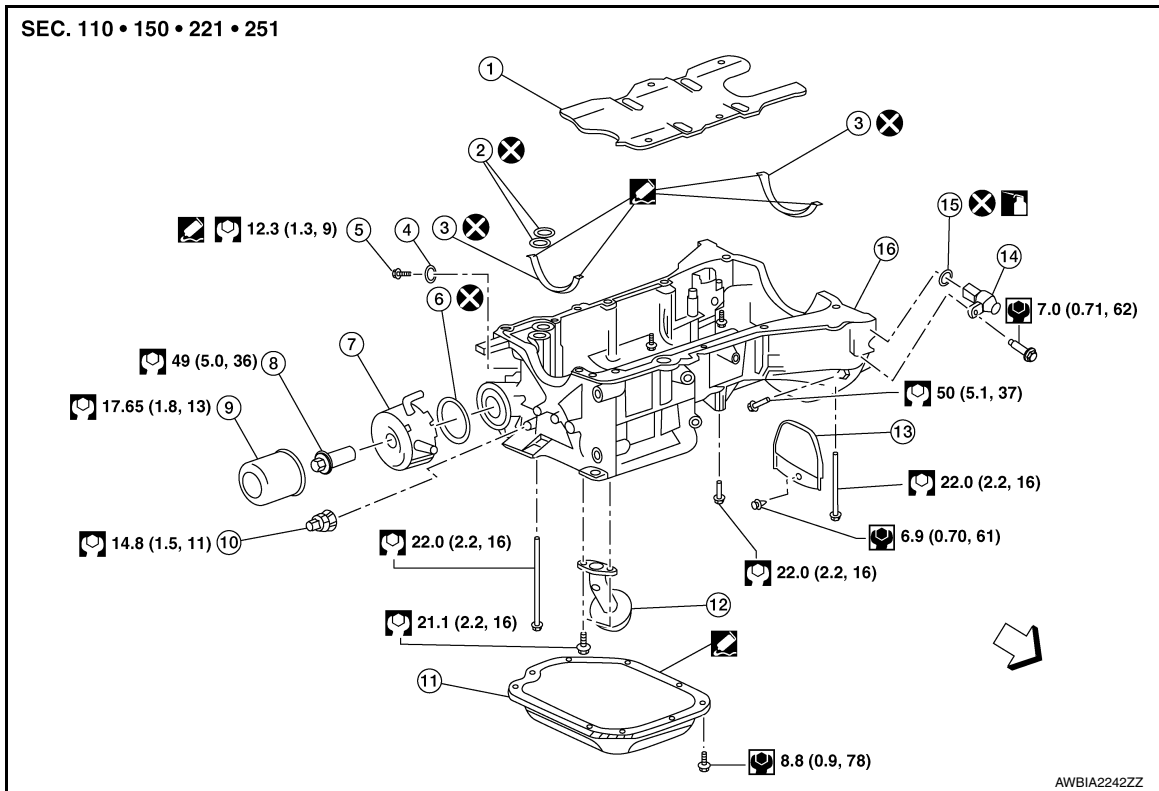

- | | | |
|-------------------------|--------------------------------------|-------------------------|
| 1. Oil pan baffle | 2. O-ring | 3. Upper oil pan gasket |
| 4. Blind plug O-ring | 5. Blind plug | 6. Oil cooler O-ring |
| 7. Oil cooler | 8. Oil cooler connection | 9. Oil filter |
| 10. Oil pressure sensor | 11. Lower oil pan | 12. Oil strainer |
| 13. Rear cover plate | 14. Crankshaft position sensor (POS) | 15. O-ring |
| 16. Upper oil pan | ↩ Front | |

Removal and Installation (Lower Oil Pan)

INFOID:000000012229527

REMOVAL

WARNING:

• Do not remove the oil pan until the exhaust system and cooling system have completely cooled off.

1. Drain the engine oil. Refer to [LU-9, "Changing Engine Oil"](#).
2. Loosen the lower oil pan bolts in the reverse order as shown.

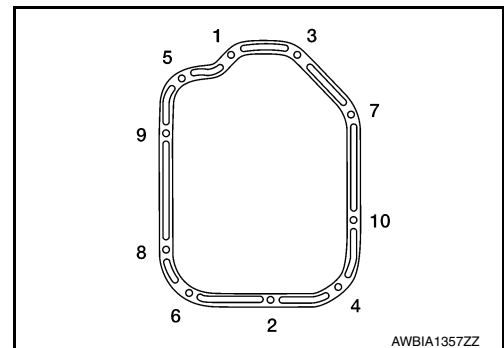

3. Remove the lower oil pan.

OIL PAN AND OIL STRAINER

< REMOVAL AND INSTALLATION >

- a. Insert Tool (A) between the lower oil pan and the upper oil pan.

Tool number : KV10111100 (J-37228)

CAUTION:

- Be careful not to damage the mating surface.
- Do not insert a screwdriver or similar tool, this will damage the mating surfaces.

- b. In areas where the cutter is difficult to use, use a plastic hammer to lightly tap (1) the cutter where the liquid gasket is applied. Use a plastic hammer to slide (2) the cutter by tapping on the side.
4. If re-installing the original lower oil pan, remove the old liquid gasket from the mating surfaces using a scraper.
- Also remove the old liquid gasket from mating surface of the upper oil pan.
 - Remove the old liquid gasket from the bolt holes and threads.

CAUTION:

Do not scratch or damage the mating surfaces when cleaning off the old liquid gasket.

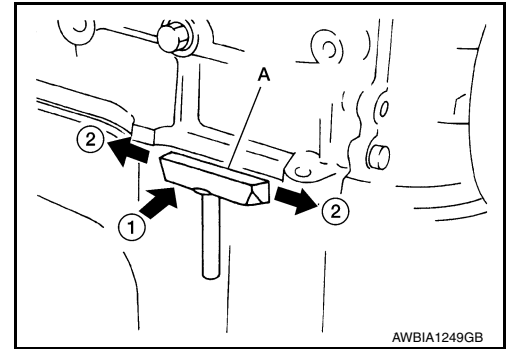

INSPECTION AFTER REMOVAL

Clean oil strainer if any object is attached.

INSTALLATION

1. Apply a continuous bead of liquid gasket to the lower oil pan groove (A) and bolt hole (B) as shown.
- Use Genuine Silicone RTV Sealant, or equivalent. Refer to [GI-22. "Recommended Chemical Products and Sealants"](#).
 - Be sure the liquid gasket is 4.5 - 5.5 mm (0.177 - 0.217 in) wide.
 - Installation must be done within 5 minutes after applying liquid gasket.
2. Install the lower oil pan. Tighten the lower oil pan bolts in order as shown.
- Wait at least 30 minutes before refilling the engine with oil.

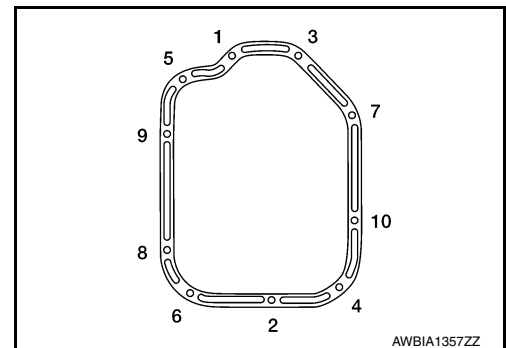
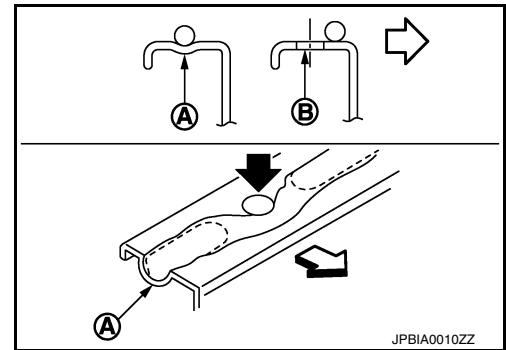

INSPECTION AFTER INSTALLATION

- Start the engine and check for leaks.
- Inspect the engine oil level. Refer to [LU-8. "Inspection"](#).

Removal and Installation (Upper Oil Pan)

INFOID:0000000012229528

REMOVAL

WARNING:

- Do not remove the oil pan until the exhaust system and cooling system have completely cooled off.
- When removing the front and rear engine through bolts and nuts, lift the engine up slightly for safety. For engine slingers, refer to [EM-107. "Removal and Installation"](#).

CAUTION:

When removing the upper oil pan from the engine, first remove the crankshaft position sensor (POS). Be careful not to damage sensor edges or signal plate teeth.

NOTE:

OIL PAN AND OIL STRAINER

< REMOVAL AND INSTALLATION >

When removing components such as hoses, tubes/lines, etc., cap or plug openings to prevent fluid from spilling.

1. Remove the engine from the vehicle. Refer to [EM-107, "Removal and Installation"](#).
2. Drain the engine oil. Refer to [LU-9, "Changing Engine Oil"](#).
3. Remove the oil level gauge guide.
4. Remove the drive belt. Refer to [EM-16, "Removal and Installation"](#).
5. Disconnect the A/C compressor harness connector.
6. Remove the A/C compressor bolts and remove the A/C compressor. Refer to [HA-34, "Removal and Installation"](#).
7. Remove the drive plate. Refer to [EM-115, "Exploded View"](#).
8. Remove coolant pipe bolts. Refer to [CO-25, "Exploded View"](#).
9. Disconnect the coolant lines from the engine oil cooler.
10. Remove the oil filter and engine oil cooler from the upper oil pan.
11. Remove the oil pressure sensor, and the crankshaft position sensor (POS) from the upper oil pan.
12. Remove the lower oil pan. Refer to [EM-39, "Removal and Installation \(Lower Oil Pan\)"](#).
13. Remove the upper oil pan.
 - a. Loosen the bolts in the order as shown, using power tool.

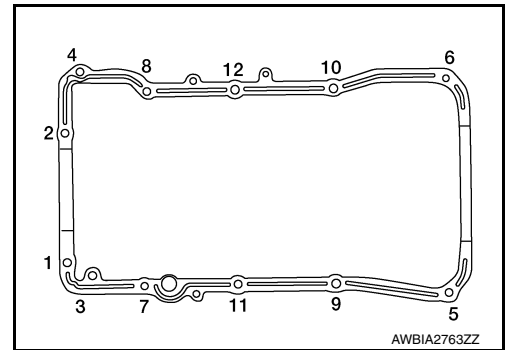

- b. Insert a suitable tool (A) into the notch (B) of the upper oil pan (1) as shown.
 - c. Pry off the upper oil pan (1) by moving the suitable tool up and down (2) as shown.

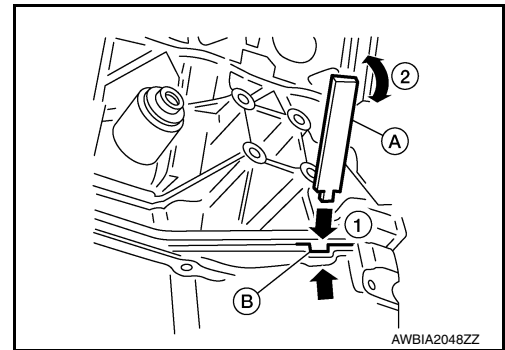

14. Remove the O-rings (2) from the bottom of the cylinder block (1) and oil pump housing. Use new O-rings for installation.

← : Engine front

CAUTION:
Do not reuse O-rings.

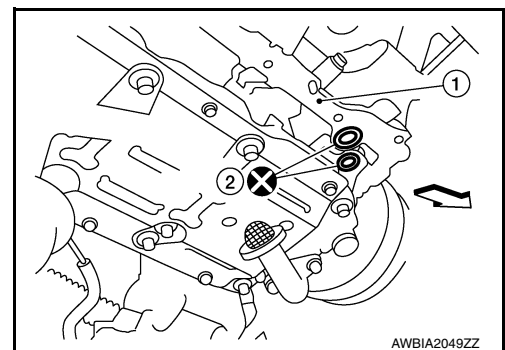

OIL PAN AND OIL STRAINER

< REMOVAL AND INSTALLATION >

15. Remove front cover gasket (A) and rear oil seal retainer gasket (B).

← : Engine front

CAUTION:
Do not reuse gaskets.

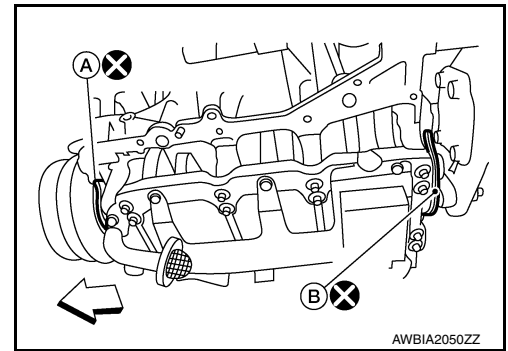

16. Remove the oil strainer.
17. If reinstalling the original oil pan, remove the old sealant from the mating surfaces using a suitable tool (A).
- Also remove the old sealant from mating surface of the cylinder block.
 - Remove the old sealant from the bolt holes and threads.

CAUTION:
Do not scratch or damage the mating surfaces when cleaning off the old sealant.

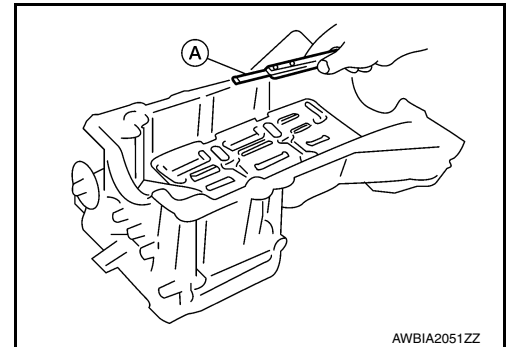

INSPECTION AFTER REMOVAL

Clean oil strainer if any object is attached.

INSTALLATION

1. Install oil strainer and tighten bolts to specified torque. Refer to [EM-39. "Exploded View"](#).
2. Apply Genuine Silicone RTV Sealant or equivalent (A) to the front cover gasket and the rear oil seal retainer gasket as shown. Refer to [GI-22. "Recommended Chemical Products and Sealants"](#).

CAUTION:

- Installation should be done within 5 minutes after applying liquid gasket.
- Do not fill the engine with oil for at least 30 minutes after the components are installed to allow the sealant to cure.

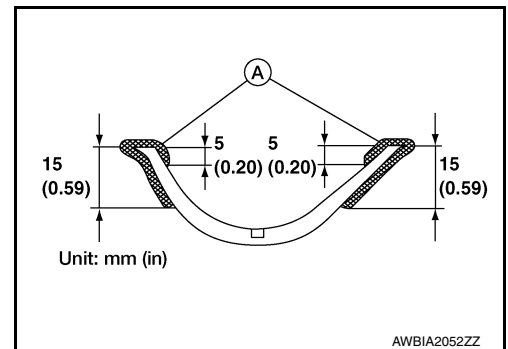

3. Install the front cover gasket (A) and rear oil seal retainer gasket (B) as shown.

CAUTION:
Do not reuse front cover gasket or rear oil seal retainer gasket.

← : Engine front

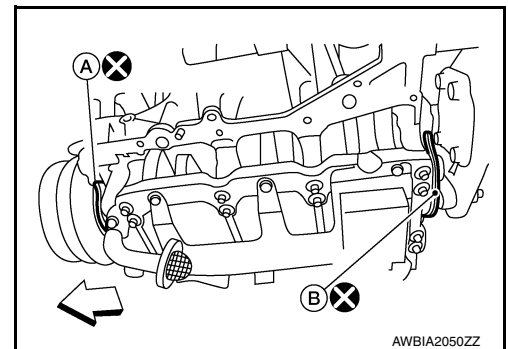

OIL PAN AND OIL STRAINER

< REMOVAL AND INSTALLATION >

4. Apply a bead of sealant to the cylinder block mating surface of the upper oil pan as shown.

CAUTION:

- Installation should be done within 5 minutes after applying liquid gasket.
- Do not fill the engine with oil for at least 30 minutes after the components are installed to allow the sealant to cure.

NOTE:

- Apply liquid gasket to the outside of bolt holes 5, 6, 10, 11 and 12.
- Apply liquid gasket to the inside of the other bolt holes.

- a. Be sure the sealant is applied 5.0 mm (0.197 in) as shown (A). Increase the bead to 4.5 - 5.5 mm (0.177 - 0.217 in) at the four places indicated (B).
- b. Use Genuine Silicone RTV Sealant, or equivalent at groove (A) and bolt hole (B) as shown. Refer to [GI-22, "Recommended Chemical Products and Sealants"](#).

← : Engine front

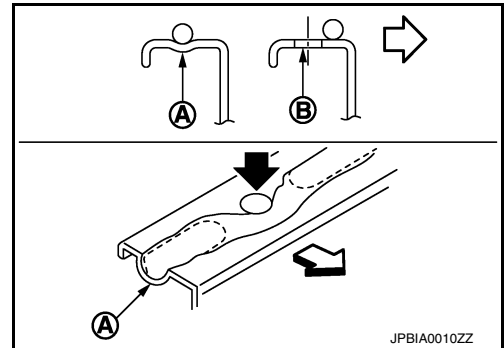
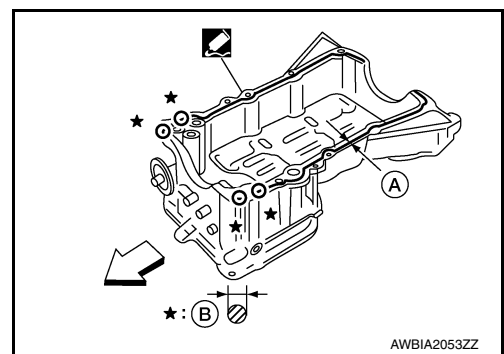

5. Install new O-rings (2) on the cylinder block (1) and oil pump body.

CAUTION:

Do not reuse O-rings.

← : Engine front

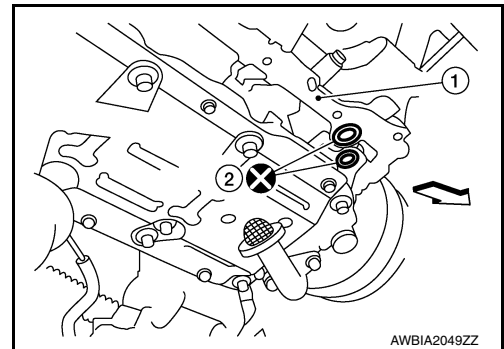

6. Install the upper oil pan.
- Tighten upper oil pan bolts in the order as shown.

CAUTION:

Do not fill the engine with oil for at least 30 minutes after the components are installed to allow the sealant to cure.

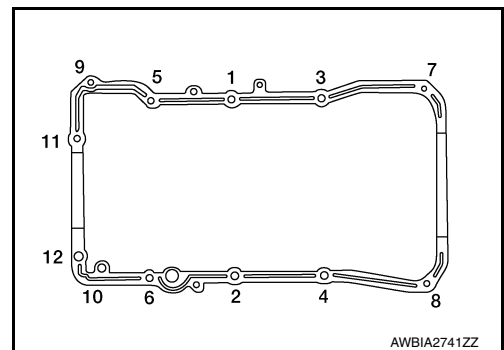

7. Install the lower oil pan. Refer to [EM-39, "Removal and Installation \(Lower Oil Pan\)"](#).
8. Installation of the remaining components is in the reverse order of removal.

INSPECTION AFTER INSTALLATION

- Before starting engine, check oil/fluid levels including engine coolant and engine oil. If there is less than required quantity, fill to the specified level. Refer to [MA-16, "FOR USA AND CANADA : Fluids and Lubricants"](#) or [MA-17, "FOR MEXICO : Fluids and Lubricants"](#).
- Use procedure below to check for fuel leaks.
- Turn ignition switch ON (with engine stopped). With fuel pressure applied to fuel piping, check for fuel leaks at connection points.
- Start engine. With engine speed increased, check again for fuel leaks at connection points.

OIL PAN AND OIL STRAINER

< REMOVAL AND INSTALLATION >

- Run engine to check for unusual noise and vibration.

NOTE:

If hydraulic pressure inside timing chain tensioner drops after removal and installation, slack in the guide may generate a pounding noise during and just after engine start. However, this is normal. Noise will stop after hydraulic pressure rises.

- Warm up engine thoroughly to make sure there is no leaks of fuel, exhaust gas, or any oils/fluids including engine oil and engine coolant.
- Bleed air from passages in lines and hoses, such as in cooling system.
- After cooling down engine, again check oil/fluid levels including engine oil and engine coolant. Refill to specified level, if necessary.
- Summary of the inspection items:

Item		Before starting engine	Engine running	After engine stopped
Engine coolant		Level	leaks	Level
Engine oil		Level	leaks	Level
Transmission/ transaxle fluid	A/T and CVT Models	leaks	Level/leaks	leaks
	M/T Models	Level/leaks	leaks	Level/leaks
Other oils and fluids*		Level	leaks	Level
Fuel		leaks	leaks	leaks
Exhaust gas		—	leaks	—

*Power steering fluid, brake fluid, etc.

IGNITION COIL

< REMOVAL AND INSTALLATION >

IGNITION COIL

Exploded View

INFOID:0000000011933762

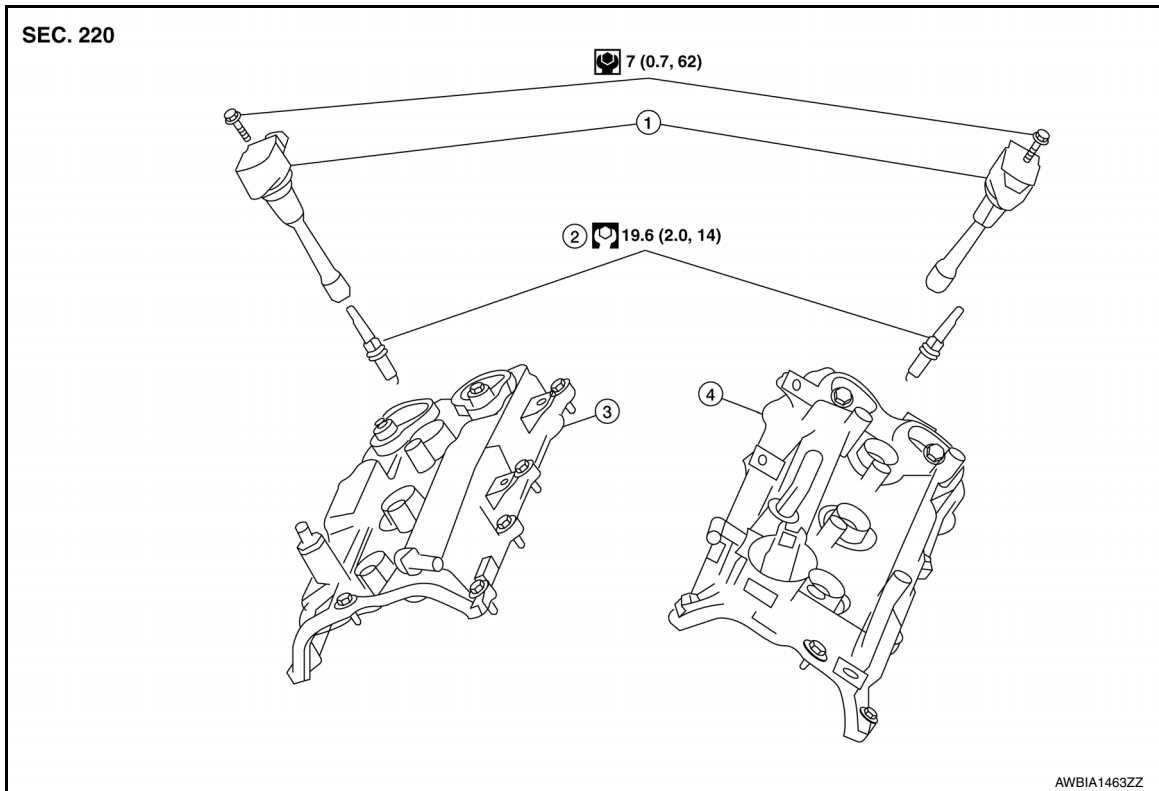

- 1. Ignition coil
- 2. Spark plug
- 3. Rocker cover (RH)
- 4. Rocker cover (LH)

Removal and Installation (LH)

INFOID:0000000011933763

REMOVAL

1. Remove engine room cover. Refer to [EM-25. "Removal and Installation"](#).
2. Disconnect ignition coil harness connector.
3. Remove the ignition coil.

CAUTION:
Do not shock ignition coil.

INSTALLATION

Installation is in the reverse order of removal.

Removal and Installation (RH)

INFOID:0000000011933764

REMOVAL

1. Remove the intake manifold collector. Refer to [EM-27. "Removal and Installation"](#).
2. Disconnect ignition coil harness connector.
3. Remove the ignition coil.

CAUTION:
Do not shock ignition coil.

INSTALLATION

Installation is in the reverse order of removal.

FUEL INJECTOR AND FUEL TUBE

< REMOVAL AND INSTALLATION >

FUEL INJECTOR AND FUEL TUBE

Exploded View

INFOID:000000012229923

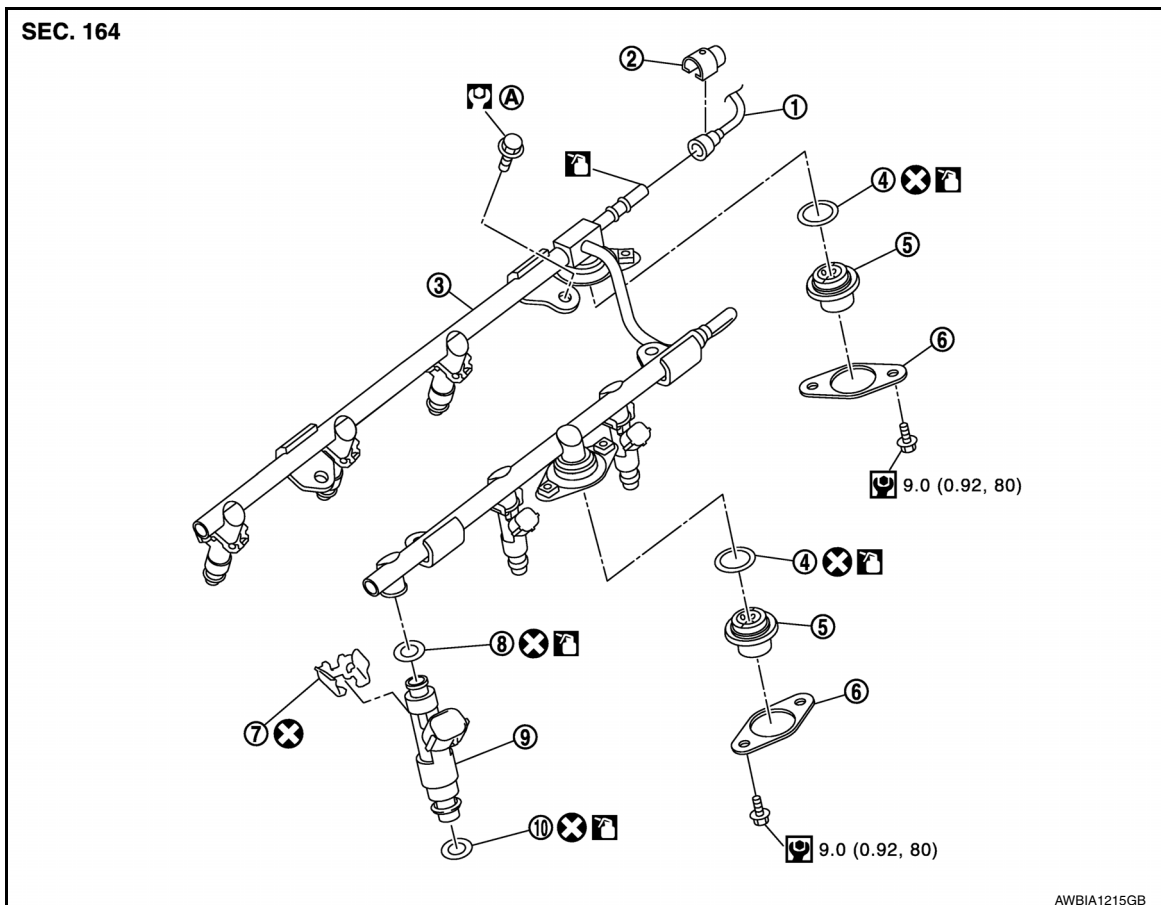

- | | | |
|--------------------|--------------------------|--------------------|
| 1. Fuel feed hose | 2. Quick connector cap | 3. Fuel tube |
| 4. O-ring | 5. Fuel damper | 6. Fuel damper cap |
| 7. Clip | 8. O-ring (black) | 9. Fuel injector |
| 10. O-ring (green) | A. Refer to INSTALLATION | |

Removal and Installation

INFOID:000000012230015

REMOVAL

WARNING:

- Put a "CAUTION: FLAMMABLE" sign in the workshop.
- Be sure to work in a well ventilated area and furnish workshop with a CO₂ fire extinguisher.
- Do not smoke while servicing fuel system. Keep open flames and sparks away from the work area.
- To avoid the danger of being scalded, do not drain engine coolant when engine is hot.

CAUTION:

- Apply new engine oil when installing the parts as specified to do so.
- Do not remove or disassemble parts unless instructed as shown.

NOTE:

When removing components such as hoses, tubes/lines, etc., cap or plug openings to prevent fluid from spilling.

1. Release the fuel pressure. Refer to [EC-168, "Work Procedure"](#).
2. Disconnect the battery negative terminal. Refer to [PG-106, "Exploded View"](#).
3. Remove intake manifold collector. Refer to [EM-27, "Removal and Installation"](#).

FUEL INJECTOR AND FUEL TUBE

< REMOVAL AND INSTALLATION >

4. When separating fuel feed hose and fuel tube connection, disconnect quick connector using tool as follows:

Tool number : 16441 6N210 (J-45488)

- a. Remove quick connector cap from quick connector.
- b. Disconnect quick connector from fuel tube as follows:

CAUTION:

Disconnect quick connector by special service tool, not by picking out retainer tabs.

- i. With the sleeve side of Tool facing toward the quick connector, install the Tool onto fuel tube.
- ii. Insert the Tool (A) into quick connector (2) until sleeve (B) contacts and goes no further. Hold Tool on that position.

(C) : Insert and retain

CAUTION:

Inserting Tool hard will not disconnect quick connector. Hold quick connector release where it contacts and goes no further.

- iii. Draw and pull out quick connector straight from fuel tube (1).

CAUTION:

- Do not reuse O-ring.
- Pull quick connector (E) holding position (D) as shown.
- Do not pull with lateral force applied. O-ring inside quick connector may be damaged.
- Prepare container and cloth beforehand as fuel will leak out.
- Avoid fire and sparks.
- Keep parts away from heat source. Especially, be careful when welding is performed around them.
- Do not expose parts to battery electrolyte or other acids.
- Do not bend or twist connection between quick connector and fuel feed hose (with damper) during installation/removal.
- To keep clean the connecting portion and to avoid damage and foreign materials, cover them completely with plastic bags, etc. (A) or something similar.

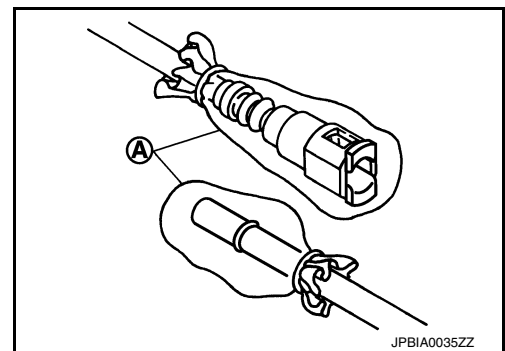
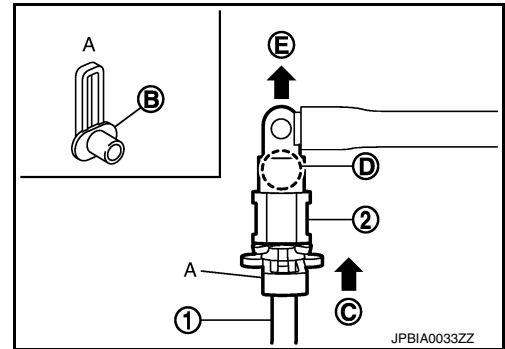

5. Disconnect harness connector from fuel injector.
6. Loosen bolts in reverse order as shown, and remove fuel tube and fuel injector assembly.

← : Engine front

CAUTION:

Do not tilt fuel tube, or remaining fuel in pipes may flow out from pipes.

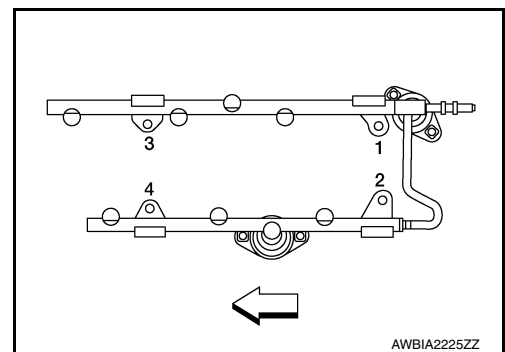

7. Remove fuel injector from fuel tube as follows:

FUEL INJECTOR AND FUEL TUBE

< REMOVAL AND INSTALLATION >

- a. Open and remove clip (1).

- (3) : O-ring (green)
- (4) : O-ring (black)
- (A) : Installed condition
- (B) : Clip groove

- b. Remove fuel injector (2) from fuel tube (5) by pulling straight.

CAUTION:

- Do not reuse O-rings.
- Be careful with remaining fuel that may go out from fuel tube.
- Be careful not to damage injector nozzle during removal.
- Do not bump or drop fuel injector.
- Do not disassemble fuel injector.

8. Remove fuel damper from fuel tube, (if necessary).

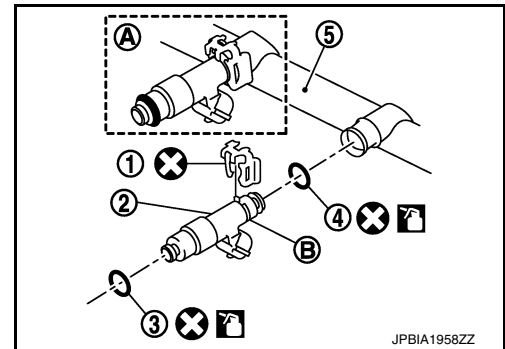

JPBIA1958ZZ

INSTALLATION

1. Install fuel damper as follows:

- a. Install new O-ring (2) to fuel tube (1) as shown. When handling new O-ring, be careful of the following:

CAUTION:

- Do not reuse O-ring.
- Handle O-ring with bare hands. Do not wear gloves.
- Lubricate O-ring with new engine oil.
- Do not clean O-ring with solvent.
- Check that O-ring and its mating part are free of foreign material.
- When installing O-ring, be careful not to scratch it with tool or fingernails. Also be careful not to twist or stretch O-ring. If O-ring was stretched while it was being attached, do not insert it quickly into fuel tube.
- Insert new O-ring straight into fuel tube. Do not twist it.

- b. Install spacer (3) to fuel damper (4).

- c. Insert fuel damper straight into fuel tube.

CAUTION:

- Insert straight, checking that the axis is lined up.
- Do not pressure-fit with excessive force.

Reference value : 130 N (13.3 kg, 29.2 lb)

- Insert fuel damper until (B) is touching (A) of fuel tube.

- d. Tighten bolts evenly in turn.

- After tightening bolts, check that there is no gap between fuel damper cap (5) and fuel tube.

2. Install new O-rings to fuel injector paying attention to the following.

CAUTION:

- Do not reuse O-rings.
- Upper and lower O-rings are different. Be careful not to confuse them.

Fuel tube side : Black

Nozzle side : Green

- Handle O-ring with bare hands. Do not wear gloves.
- Lubricate O-ring with new engine oil.
- Do not clean O-ring with solvent.
- Check that O-ring and its mating part are free of foreign material.
- When installing O-ring, be careful not to scratch it with tool or fingernails. Also be careful not to twist or stretch O-ring. If O-ring was stretched while it was being attached, do not insert it quickly into fuel tube.
- Insert O-ring straight into fuel injector. Do not twist it.

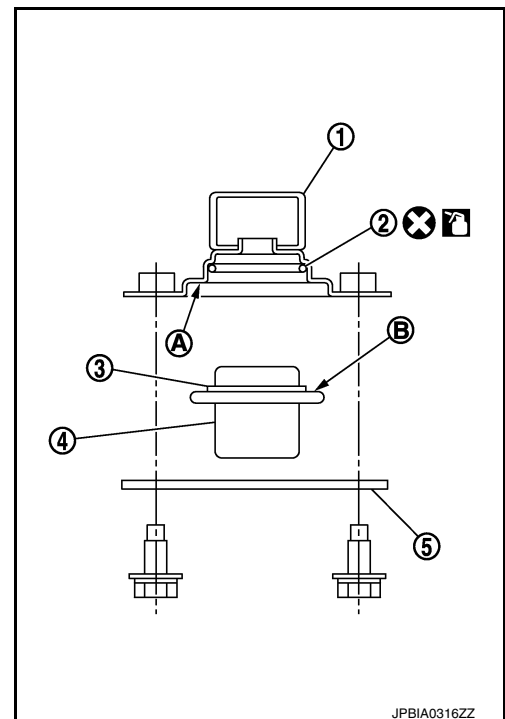

JPBIA0316ZZ

FUEL INJECTOR AND FUEL TUBE

< REMOVAL AND INSTALLATION >

3. Install fuel injector to fuel tube as follows:
 - a. Insert clip (3) into clip groove (F) on fuel injector (5).

- (2) : O-ring (black)
- (4) : O-ring (green)

- Insert clip so that protrusion (E) of fuel injector matches cutout (C) of clip.

CAUTION:

- Do not reuse O-rings.
- Do not reuse clip. Replace it with new one.
- Be careful to keep clip from interfering with O-ring. If interference occurs, replace O-ring.

- b. Insert fuel injector into fuel tube (1) with clip attached.
 - Insert it while matching it to the axial center.
 - Insert fuel injector so that protrusion (A) of fuel tube matches cutout (B) of clip.
 - Check that fuel tube flange (G) is securely fixed in flange fixing groove (D) on clip.
- c. Check that installation is complete by checking that fuel injector does not rotate or come off.
 - Check that protrusions of fuel injectors and fuel tubes are aligned with cutouts of clips after installation.

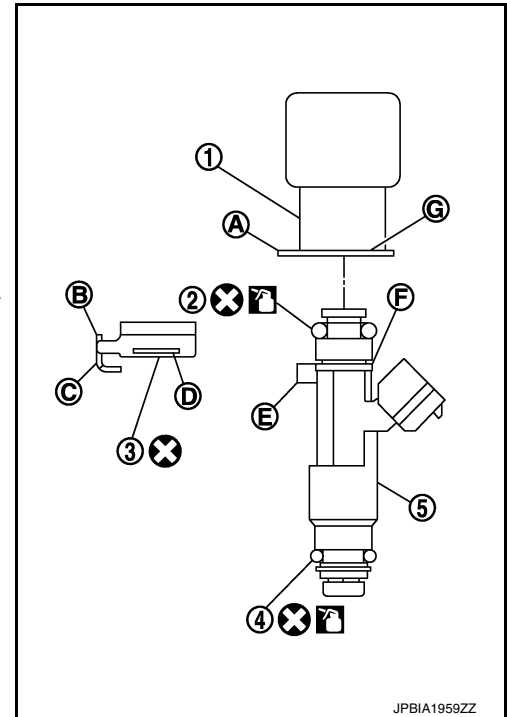

4. Install fuel tube and fuel injector assembly to intake manifold.

CAUTION:

Be careful not to let tip of injector nozzle come in contact with other parts.

- Tighten bolts in two steps in numerical order as shown.

↶ : Engine front

- 1st step** : 10.1 N·m (1.0 kg-m, 7 ft-lb)
- 2nd step** : 22.0 N·m (2.2 kg-m, 16 ft-lb)

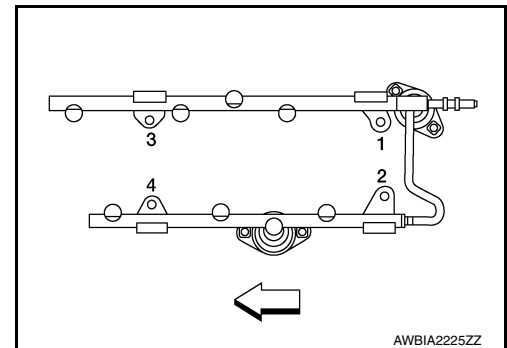

5. Connect fuel injector harness.
6. Install intake manifold collector. Refer to [EM-27. "Removal and Installation"](#).
7. Connect quick connector between fuel feed hose and fuel tube connection with the following procedure:
 - a. Check no foreign substances are deposited in and around fuel tube and quick connector, and that there is no damage on them.
 - b. Thinly apply new engine oil around fuel tube from tip end to spool end.
 - c. Align center to insert quick connector straight into fuel tube.
 - Insert quick connector (1) to fuel tube until top spool (2) is completely inside quick connector, and 2nd level spool (3) exposes right below quick connector.

- (B) : Installed condition
- ↶ : Upright insertion

CAUTION:

- Do not reuse O-ring.
- Hold (A) position as shown when inserting fuel tube into quick connector.

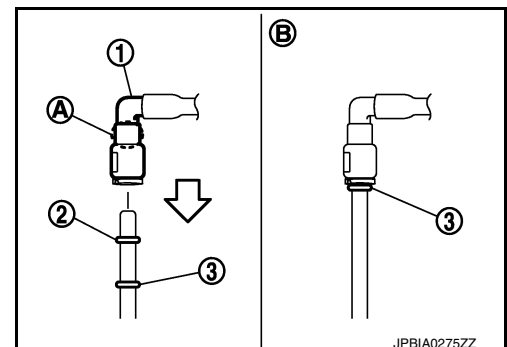

FUEL INJECTOR AND FUEL TUBE

< REMOVAL AND INSTALLATION >

- Carefully align center to avoid inclined insertion to prevent damage to O-ring inside quick connector.
 - Insert until you hear a “click” sound and actually feel the engagement.
 - To avoid misidentification of engagement with a similar sound, be sure to perform the next step.
- d. Pull quick connector by hand holding position. Check it is completely engaged (connected) so that it does not come out from fuel tube.
- e. Install quick connector cap (3) to quick connector.

- (1) : Fuel feed hose
(2) : Fuel tube
(B) : Upper view

- Install quick connector cap with arrow (A) on surface facing in direction of quick connector (fuel feed hose side).

CAUTION:

If quick connector cap cannot be installed smoothly, quick connector may have not been installed correctly. Check connection again.

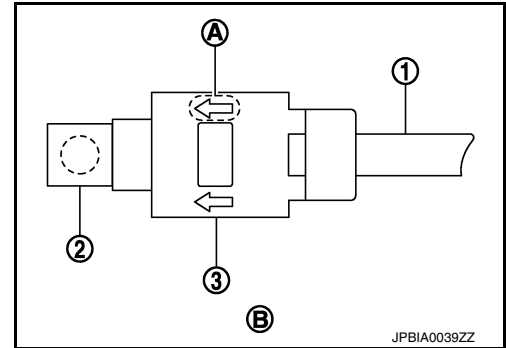

- f. Secure fuel feed hose to clamp of quick connector cap.
8. Installation of the remaining components is in the reverse order of removal.

INSPECTION AFTER INSTALLATION

Make sure there is no fuel leakage at connections as follows:

1. Apply fuel pressure to fuel lines by turning ignition switch ON (with engine stopped). Then check for fuel leaks at connections.
2. Start the engine and rev it up and check for fuel leaks at connections.

WARNING:

Do not touch engine immediately after stopping as engine is extremely hot.

NOTE:

Use mirrors for checking on connections out of the direct line of sight.

Inspection

INFOID:000000011933767

INSPECTION AFTER INSTALLATION

Check For Fuel Leaks

1. Turn ignition switch “ON” with the engine stopped. With fuel pressure applied to fuel piping, check for fuel leaks at connection points. Repair as necessary.

NOTE:

Use mirrors for checking at points out of clear sight.

2. Start the engine. With engine speed increased, check again for fuel leaks at connection points. Repair as necessary.

CAUTION:

Do not touch the engine immediately after stopped, as the engine becomes extremely hot.

ROCKER COVER

< REMOVAL AND INSTALLATION >

ROCKER COVER

Exploded View

INFOID:0000000011933768

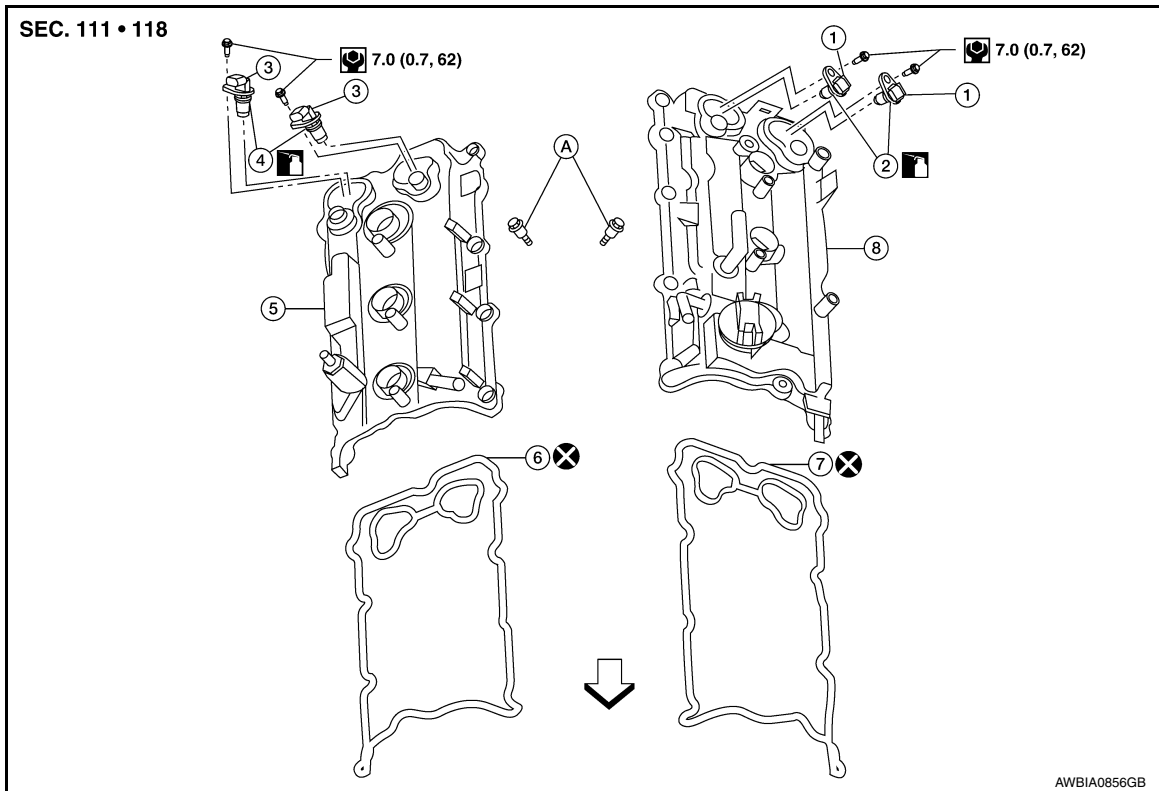

- | | | |
|-----------------------------------|----------------------|-----------------------------------|
| 1. Camshaft position sensors (LH) | 2. O-rings | 3. Camshaft position sensors (RH) |
| 4. O-rings | 5. Rocker cover (RH) | 6. Rocker cover gasket (RH) |
| 7. Rocker cover gasket (LH) | 8. Rocker cover (LH) | A. Refer to INSTALLATION |

← Front

Removal and Installation (LH)

INFOID:0000000011933769

REMOVAL

1. Remove the engine room cover. Refer to [EM-25. "Removal and Installation"](#).
2. Remove front air duct. Refer to [EM-26. "Removal and Installation"](#).
3. Remove blow by hose from rocker cover.
4. Remove camshaft position sensors.

CAUTION:

- Handle carefully to avoid dropping and shocks.
- Do not disassemble.
- Do not allow metal powder to adhere to magnetic part at sensor tip (A).
- Do not place sensors in a location where they are exposed to magnetism.

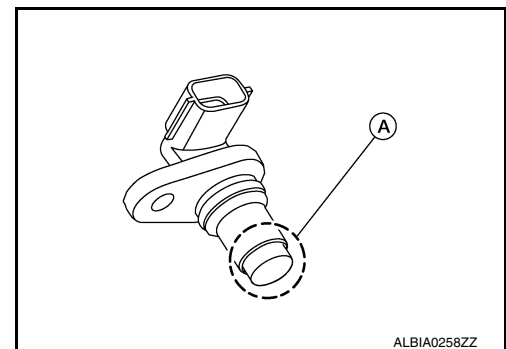

5. Remove the ignition coils. Refer to [EM-45. "Removal and Installation \(LH\)"](#).

CAUTION:

Do not shock ignition coils.

ROCKER COVER

< REMOVAL AND INSTALLATION >

6. Remove oil level gauge guide.
7. Remove (LH) rocker cover bolts from cylinder head in the reverse order as shown.

← : Engine front

8. Remove the rocker cover and gasket.

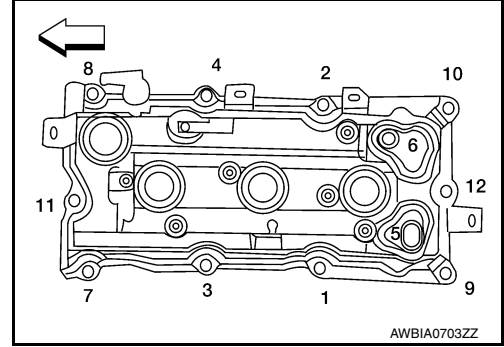

INSTALLATION

Installation is in the reverse order of removal.

CAUTION:

Do not reuse rocker cover gasket.

- Apply sealant to the areas on the front corners using a suitable tool.
- Use Genuine Silicone RTV Sealant or equivalent. Refer to [GI-22, "Recommended Chemical Products and Sealants"](#).

CAUTION:

- Installation should be done within 5 minutes after applying liquid gasket.
- Do not fill the engine with oil for at least 30 minutes after the components are installed to allow the sealant to cure.

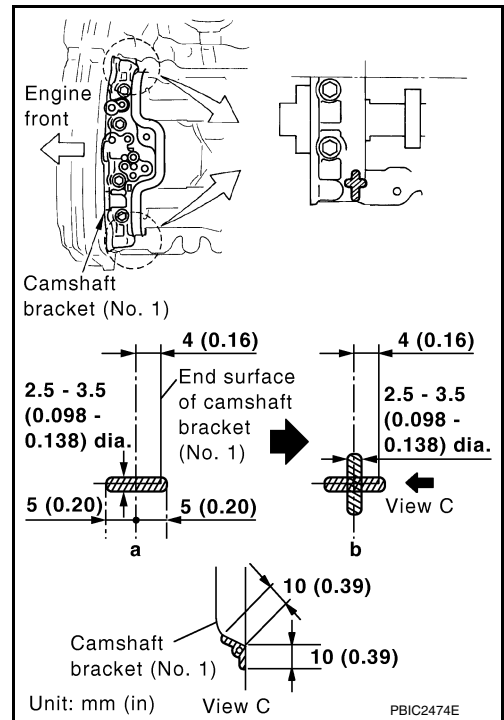

- Tighten the rocker cover bolts in two steps in the order shown.

← : Engine front

Rocker cover bolts

Step 1 : 1.96 N·m (0.20 kg-m, 17 in-lb)

Step 2 : 8.33 N·m (0.85 kg-m, 74 in-lb)

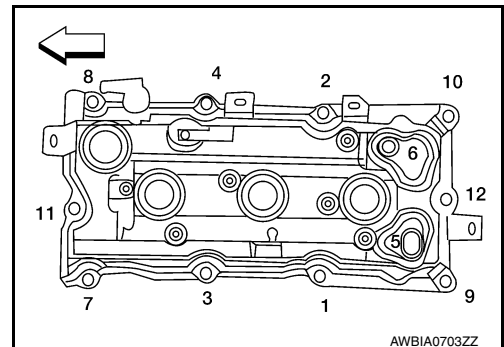

Removal and Installation (RH)

INFOID:000000011933770

REMOVAL

1. Remove the engine room cover. Refer to [EM-25, "Removal and Installation"](#).

ROCKER COVER

< REMOVAL AND INSTALLATION >

2. Remove the front air duct and air duct hose and resonator assembly. Refer to [EM-26. "Removal and Installation"](#).
3. Remove the intake manifold collector. Refer to [EM-30. "Removal and Installation"](#).
4. Remove ignition coils. Refer to [EM-45. "Removal and Installation \(RH\)"](#).

CAUTION:

Do not shock ignition coils.

5. Remove camshaft position sensors.

CAUTION:

- Handle carefully to avoid dropping and shocks.
- Do not disassemble.
- Do not allow metal powder to adhere to magnetic part at sensor tip (A).
- Do not place sensors in a location where they are exposed to magnetism.

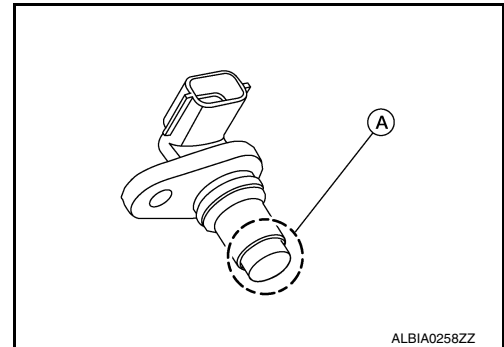

6. Remove RH rocker cover bolts from cylinder head in the reverse order as shown.

⇐ : Engine front

7. Remove the rocker cover and gasket.

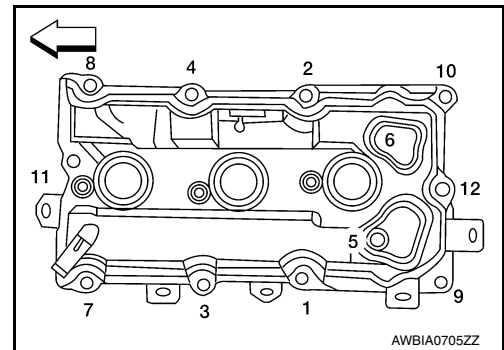

INSTALLATION

Installation is in the reverse order of removal.

CAUTION:

Do not reuse gaskets.

- Apply sealant to the areas on the front corners using a suitable tool.
- Use Genuine Silicone RTV Sealant or equivalent. Refer to [GI-22. "Recommended Chemical Products and Sealants"](#).

CAUTION:

- Installation should be done within 5 minutes after applying liquid gasket.
- Do not fill the engine with oil for at least 30 minutes after the components are installed to allow the sealant to cure.

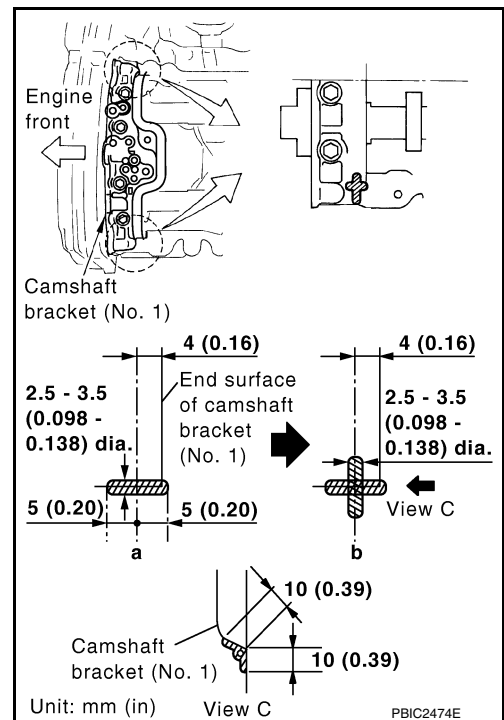

ROCKER COVER

< REMOVAL AND INSTALLATION >

- Tighten the rocker cover bolts in two steps in the order shown.

← : Engine front

Rocker cover bolts

Step 1 : 1.96 N·m (0.20 kg-m, 17 in-lb)

Step 2 : 8.33 N·m (0.85 kg-m, 74 in-lb)

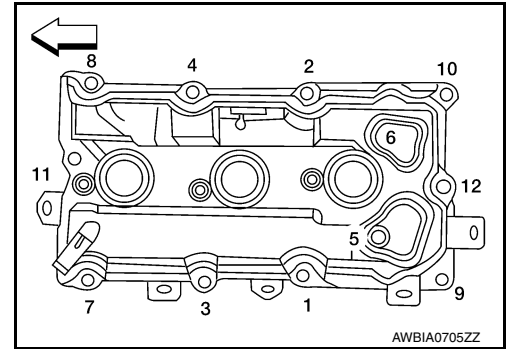

VALVE TIMING CONTROL

< REMOVAL AND INSTALLATION >

VALVE TIMING CONTROL

Exploded View

INFOID:000000012230353

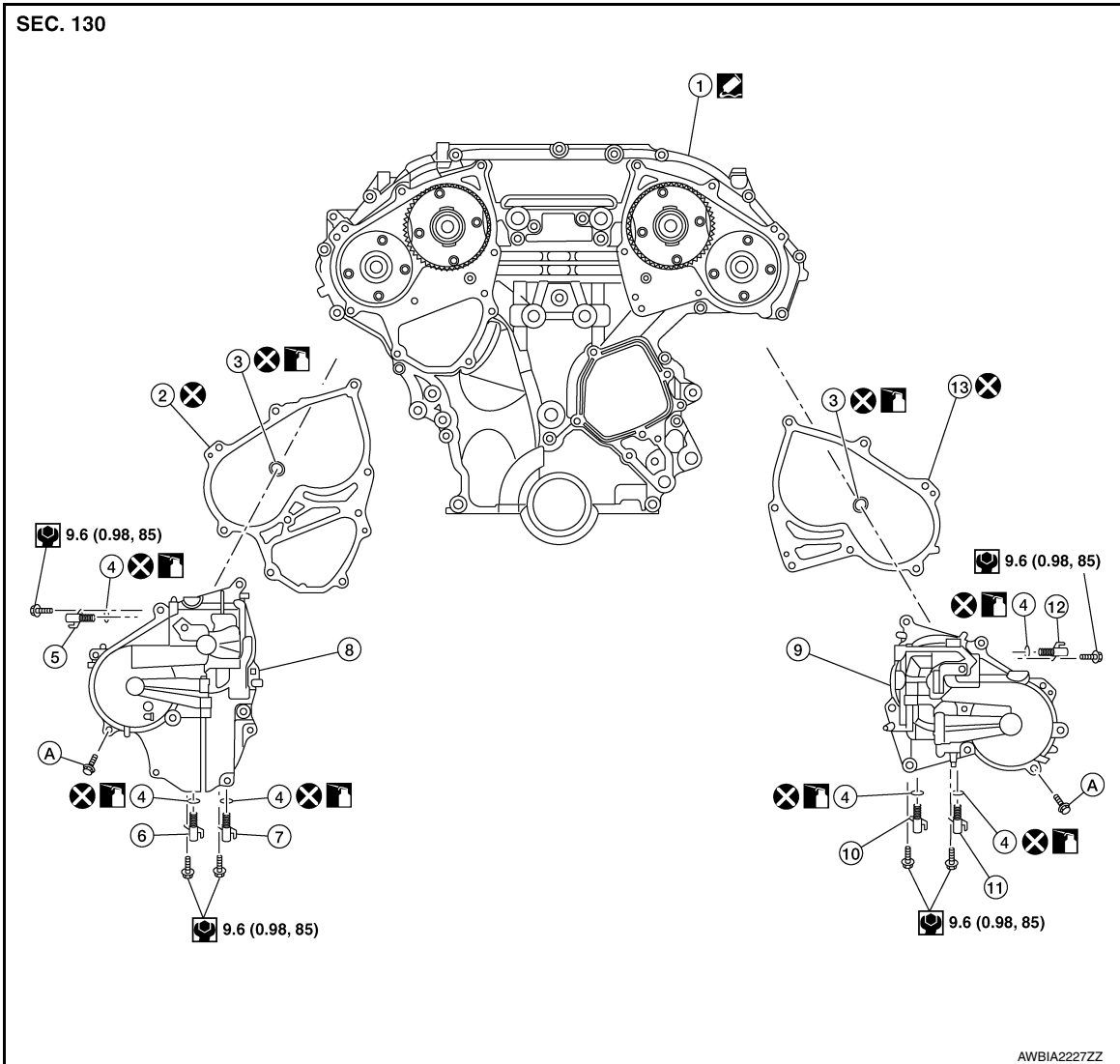

- | | | |
|--|--|---|
| 1. Front timing chain case | 2. Valve timing control cover gas-ket (bank 1) | 3. O-ring |
| 4. O-ring | 5. Intake valve timing intermediate lock control solenoid valve (bank 1) | 6. Exhaust valve timing control solenoid valve (bank 1) |
| 7. Intake valve timing control solenoid valve (bank 1) | 8. Valve timing control cover (bank 1) | 9. Valve timing control cover (bank 2) |
| 10. Intake valve timing control solenoid (bank 2) | 11. Exhaust valve timing control solenoid (bank 2) | 12. Intake valve timing intermediate lock control solenoid valve (bank 2) |
| 13. Valve timing control cover gas-ket (bank 2) | A. Refer to INSTALLATION | |

Valve Timing Control Cover (bank 1)

INFOID:000000012230354

REMOVAL

1. Disconnect battery negative terminal. Refer to [PG-101, "Exploded View"](#).
2. Remove core support cover. Refer to [EXT-22, "Exploded View"](#).

VALVE TIMING CONTROL

< REMOVAL AND INSTALLATION >

3. Remove front air duct. Refer to [EM-26, "Removal and Installation"](#).
4. Remove cowl top and cowl top extension. Refer to [EXT-25, "Removal and Installation"](#).
5. Remove coolant reservoir tank. Refer to [CO-14, "Exploded View"](#).
6. Remove power steering oil pump. Refer to [ST-43, "Removal and Installation"](#).
7. Support engine (1) and transaxle (2) using suitable jack (A).

CAUTION:

- Position a suitable jack under the engine and transaxle assembly as shown.
- Do not damage the front exhaust tube or transaxle oil pan with the jack.

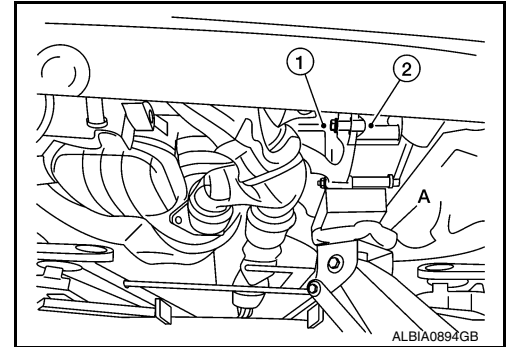

8. Remove upper torque rod, engine mounting insulator (RH), and engine mounting bracket (RH). Refer to [EM-107, "Removal and Installation"](#).
9. Disconnect intake valve timing intermediate lock control solenoid valve (bank 1) harness connector.
10. Disconnect exhaust valve timing control solenoid valve (bank 1) harness connector.
11. Disconnect intake valve timing control solenoid valve (bank 1) harness connector.
12. Remove intake valve timing intermediate lock control solenoid valve (bank 1), exhaust valve timing control solenoid valve (bank 1), and intake valve timing control solenoid valve (bank 1) from valve timing control cover (bank 1).

CAUTION:

- Do not reuse O-rings.

13. Remove valve timing control cover (bank 1).

INSTALLATION

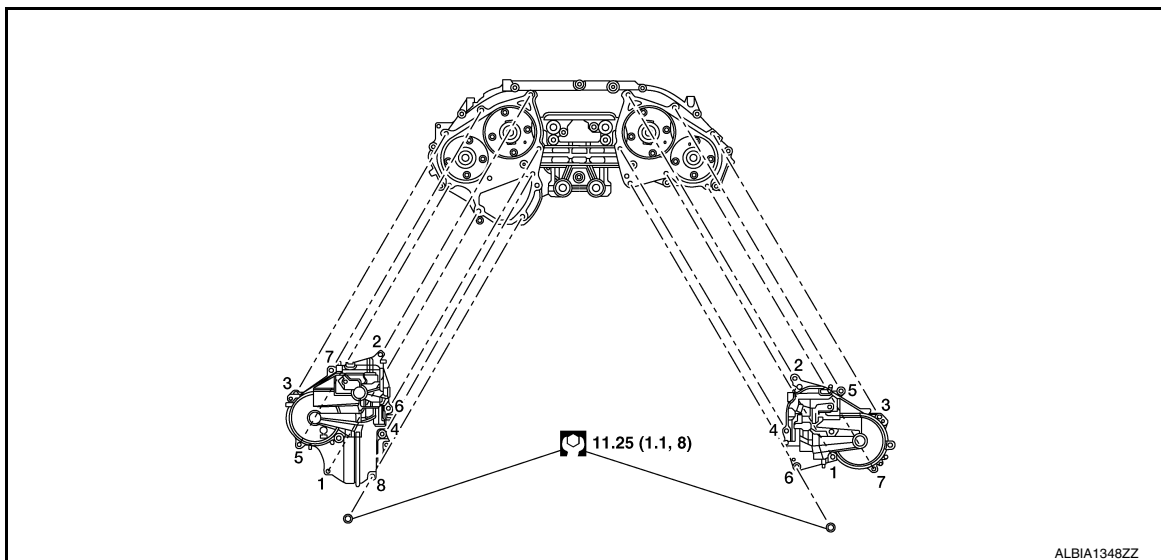

- Install valve timing control cover (bank 1). Refer to [EM-55, "Exploded View"](#).
- Tighten the timing cover bolts (A) in the order shown.
- Installation of remaining components is in the reverse order of removal.

CAUTION:

- Do not reuse O-rings.
- Lubricate O-rings with clean engine oil prior to installation.

Valve Timing Control Cover (bank 2)

INFOID:000000012230355

REMOVAL

VALVE TIMING CONTROL

< REMOVAL AND INSTALLATION >

1. Disconnect battery negative terminal. Refer to [PG-106, "Exploded View"](#).
2. Remove core support cover. Refer to [EXT-22, "Exploded View"](#).
3. Remove front air duct. Refer to [EM-26, "Removal and Installation"](#).
4. Remove coolant reservoir tank. Refer to [CO-14, "Exploded View"](#).
5. Remove power steering oil pump. Refer to [ST-43, "Removal and Installation"](#).
6. Disconnect intake valve timing intermediate lock control solenoid valve (bank 2) harness connector.
7. Disconnect exhaust valve timing control solenoid valve (bank 2) harness connector.
8. Disconnect intake valve timing control solenoid valve (bank 2) harness connector.
9. Remove intake valve timing intermediate lock control solenoid valve (bank 2), exhaust valve timing control solenoid valve (bank 2), and intake valve timing control solenoid valve (bank 2) from valve timing control cover (bank 2).

CAUTION:

Do not reuse O-rings.

10. Remove valve timing control cover (bank 2).

INSTALLATION

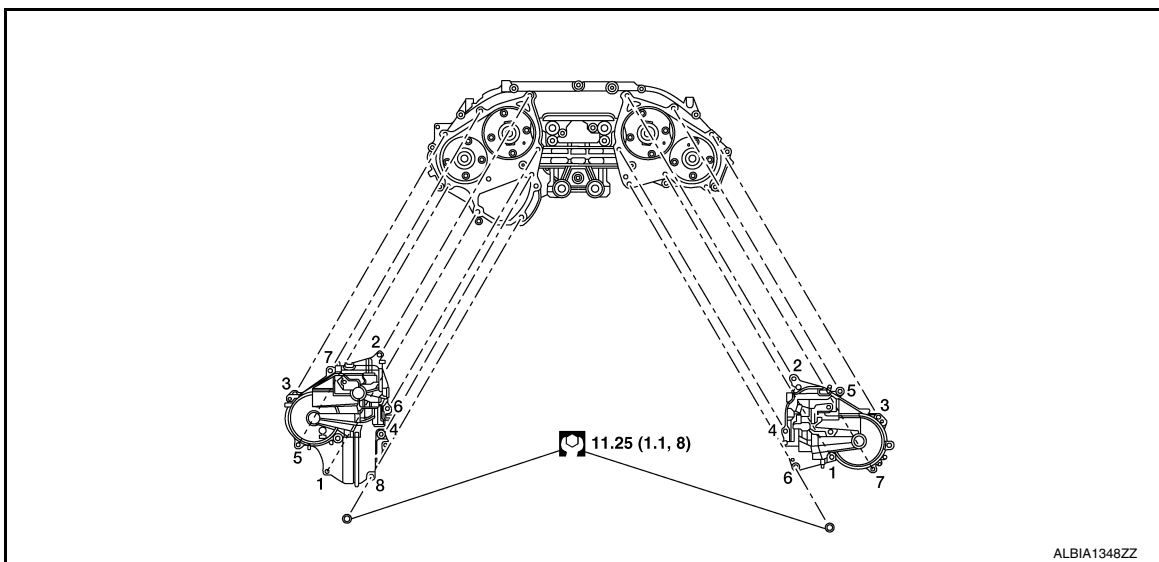

- Install valve timing control cover (bank 2).
- Install the valve timing control cover bolts (A) and tighten as shown.
- Installation of remaining components is in the reverse order of removal.

CAUTION:

- **Do not reuse O-rings.**
- **Lubricate O-rings with clean engine oil prior to installation.**

FRONT TIMING CHAIN CASE

< REMOVAL AND INSTALLATION >

FRONT TIMING CHAIN CASE

Exploded View

INFOID:000000012232192

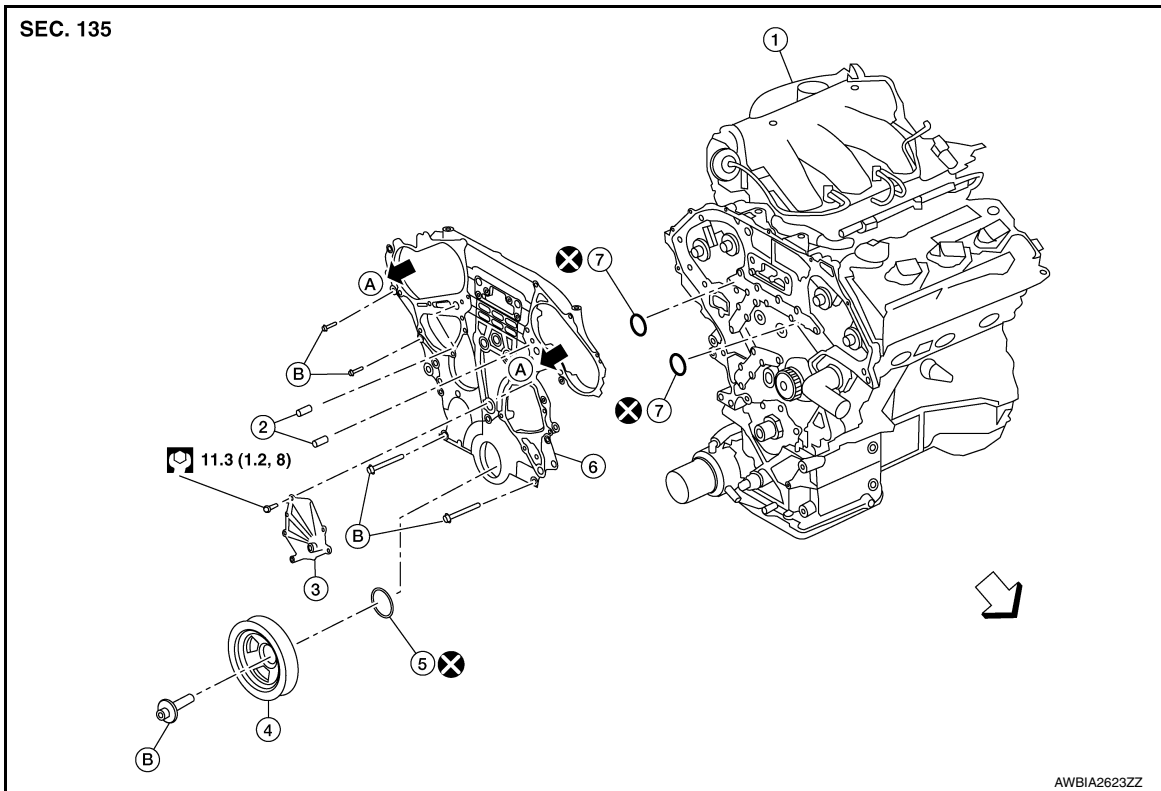

- | | | |
|----------------------|---|----------------------------|
| 1. Engine assembly | 2. Front timing chain case oil filter | 3. Water pump cover |
| 4. Crankshaft pulley | 5. Front oil seal | 6. Front timing chain case |
| 7. O-ring | A. To valve timing control cover (bank 1),
Refer to EM-55, "Valve Timing Control Cover (bank 1)" . To valve timing control cover (bank 2), Refer to EM-56, "Valve Timing Control Cover (bank 2)" . | B. Refer to INSTALLATION |

⇐ Front

Removal and Installation

INFOID:000000012232193

NOTE:

- This section describes the procedure for removal/installation of the front timing chain case without removing the engine from the vehicle.
- When rear timing chain case must be removed, remove the engine from the vehicle. Refer to [EM-107, "Removal and Installation"](#). Then remove front timing chain case, timing chain related parts, and rear timing chain case in this order, and install in reverse order of removal.
- When removing components such as hoses, tubes/lines, etc., cap or plug openings to prevent fluid from spilling.

REMOVAL

1. Drain the engine coolant from the radiator. Refer to [CO-12, "Changing Engine Coolant"](#).
2. Drain the engine oil. Refer to [LU-9, "Changing Engine Oil"](#).
3. Remove the drive belt auto tensioner. Refer to [EM-18, "Removal and Installation of Drive Belt Auto-tensioner"](#).
4. Remove the generator. Refer to [CHG-28, "Removal and Installation"](#).
5. Remove the generator bracket. Refer to [CHG-28, "Removal and Installation"](#).
6. Remove valve timing control cover (bank 1). Refer to [EM-55, "Valve Timing Control Cover \(bank 1\)"](#).

FRONT TIMING CHAIN CASE

< REMOVAL AND INSTALLATION >

7. Remove valve timing control cover (bank 2). Refer to [EM-56, "Valve Timing Control Cover \(bank 2\)"](#).
8. Remove cowl top, cowl top extension, and cowl top brace (RH). Refer to [EXT-25, "Removal and Installation"](#).
9. Remove upper radiator hose. Refer to [CO-14, "Exploded View"](#).
10. Remove lower radiator hose. Refer to [CO-14, "Exploded View"](#).
11. Disconnect the A/C tubes from the A/C compressor and position aside. Refer to [HA-36, "Exploded View"](#).
12. Disconnect the harness connector from the electronic controlled engine mount control solenoid valve.
13. Disconnect the vacuum tube from the electronic controlled engine mount control solenoid valve.
14. Remove the electronic controlled engine mount control solenoid valve.
15. Remove the rocker covers, if necessary. Refer to [EM-51, "Removal and Installation \(LH\)"](#) (bank 2) and [EM-52, "Removal and Installation \(RH\)"](#) (bank 1).

NOTE:

Necessary only when removing timing chains.

16. If removing the timing chains, obtain compression TDC of No. 1 cylinder as follows:
 - a. Rotate crankshaft pulley clockwise to align timing mark (grooved line without color) with timing indicator.

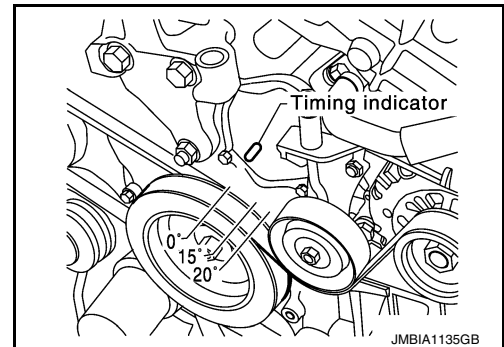

- b. Check that intake and exhaust camshaft lobes on No. 1 cylinder (right bank of engine) are located as shown.
 - If not, turn the crankshaft one revolution (360°) and align as shown.

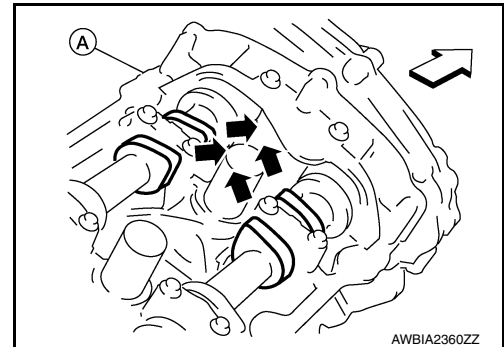

17. Remove the access plate and lock the ring gear using Tool.

Tool number : — (J-50288)

CAUTION:

Do not damage the ring gear teeth, or the signal plate teeth behind the ring gear, when installing Tool.

18. Remove the crankshaft pulley as follows:
 - a. Loosen crankshaft pulley and locate bolt seating surface at 10 mm (0.39 in) from its original position.
 - b. Position a pulley puller at recess hole of crankshaft pulley to remove crankshaft pulley.

CAUTION:

Do not use a puller claw on crankshaft pulley periphery.

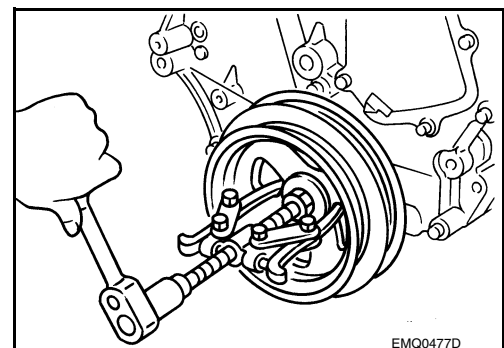

FRONT TIMING CHAIN CASE

< REMOVAL AND INSTALLATION >

19. Remove the lower oil pan. Refer to [EM-39. "Removal and Installation \(Lower Oil Pan\)".](#)
20. Remove upper oil pan bolts (1) and (2) as shown. Refer to [EM-40. "Removal and Installation \(Upper Oil Pan\)".](#)

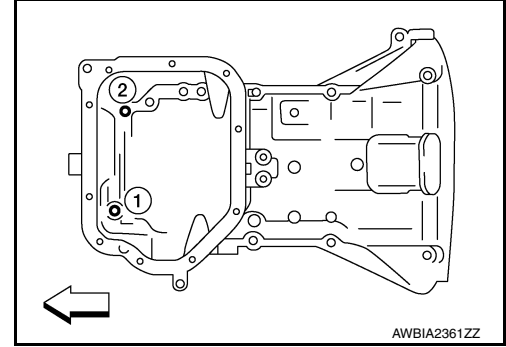

21. Disconnect the oil pressure switch harness connector.
22. If necessary, remove the water pump cover.
23. Remove the front timing chain case.
 - a. Loosen the front timing chain case bolts in reverse order as shown.

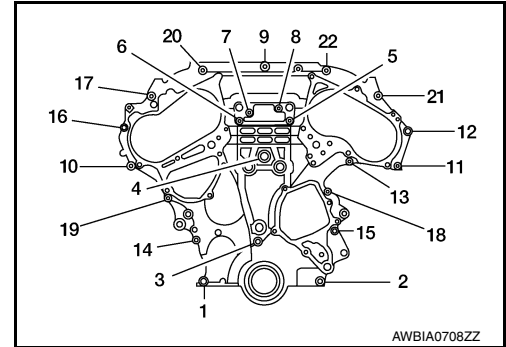

- b. Insert the appropriate size suitable tool into the notch (A) at the top of the front timing chain case as shown.
 - c. Pry off the case by moving the suitable tool (B) as shown.
 - Cut liquid gasket for removal using Tool.

Tool number: KV10111100 (J-37228)

CAUTION:

- Do not use a screwdriver or similar tool.
- After removal, handle carefully so it does not bend, or warp under a load.

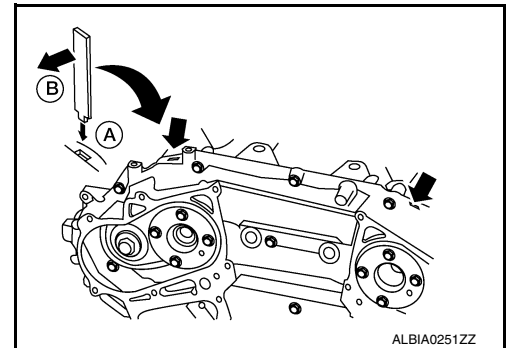

24. Remove O-rings (1) from rear timing chain case.

(A) : Bank 1 (RH)

(B) : Bank 2 (LH)

CAUTION:

Do not reuse O-rings.

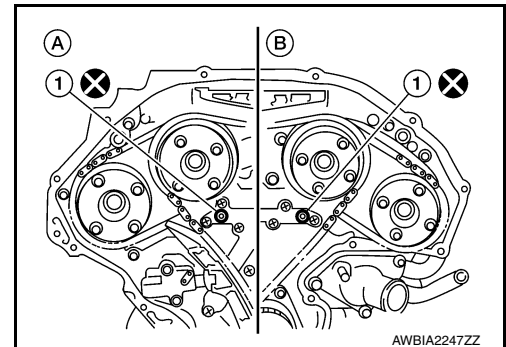

FRONT TIMING CHAIN CASE

< REMOVAL AND INSTALLATION >

25. Remove the front oil seal from the front timing chain case using suitable tool.

CAUTION:

Do not damage the front cover.

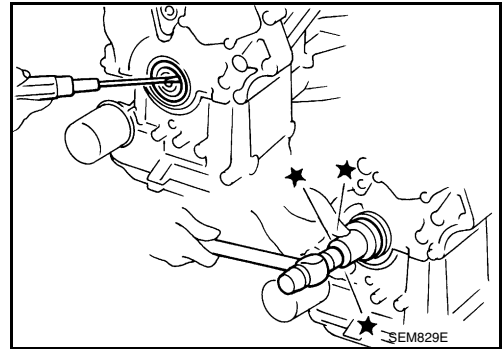

26. Remove all old Silicone RTV Sealant (A) from all the bolt holes (B) and bolts.

CAUTION:

Do not damage the threads or mating surfaces.

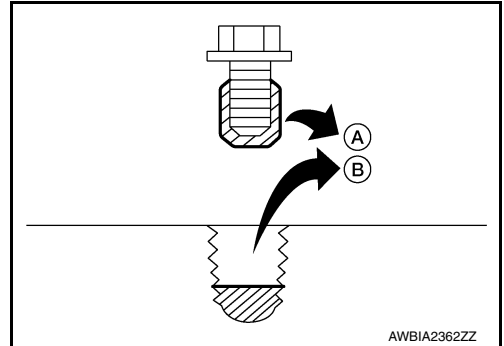

27. Use a scraper to remove all of the old Silicone RTV Sealant from the front timing chain case and opposite mating surfaces.

CAUTION:

Do not damage the mating surfaces.

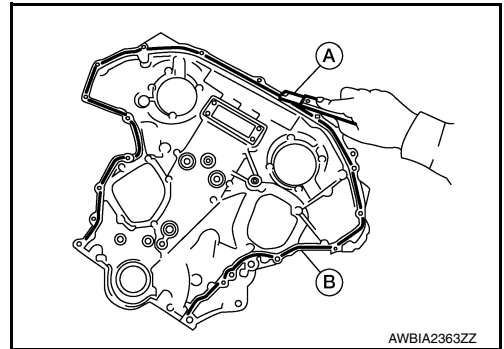

28. Remove front timing chain case oil filters (if necessary).

INSTALLATION

1. Install front timing chain case oil filter (2) (if necessary).

CAUTION:

- Insert front timing chain case oil filter (2) into the front timing chain case (1) to specified distance (A).
- Ensure oil filter mesh remains intact during insertion into the front timing chain case (1).
- Ensure oil filter mesh does not protrude from front timing chain case (1).

(A) : 1.0 - 1.5 mm (0.039 - 0.059 in)

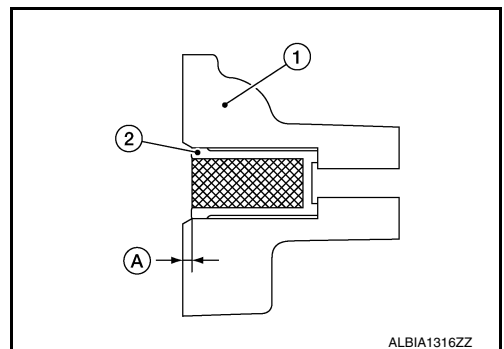

FRONT TIMING CHAIN CASE

< REMOVAL AND INSTALLATION >

2. Install dowel pins (right and left) into front timing chain case up to a point close to taper in order to shorten protrusion length.

NOTE:

Be sure to place the dowel pins in original hole locations in the front timing chain case.

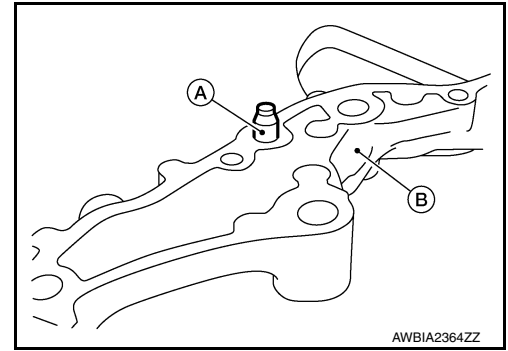

3. Install the new front oil seal on the front timing chain case. Apply new engine oil to the oil seal edges.

NOTE:

Install it so that each seal lip is oriented as shown.

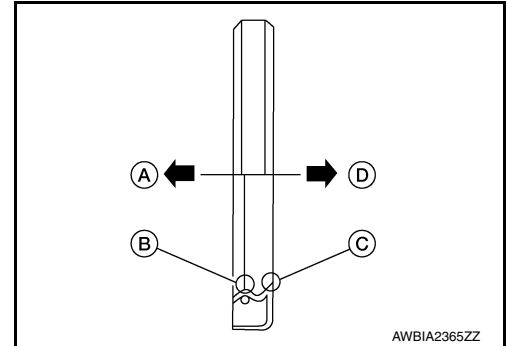

- a. Install the new front oil seal so that it becomes flush with the face with front timing chain case using suitable tool.

CAUTION:

Press fit straight and avoid causing burrs or tilting the oil seal.

NOTE:

Make sure the garter spring is in position and seal lip is not inverted.

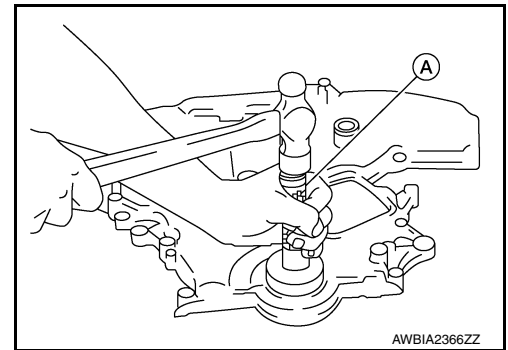

4. Install new O-rings (1) on rear timing chain case.

(A) : Bank 1 (RH)

(B) : Bank 2 (LH)

CAUTION:

Do not reuse O-rings.

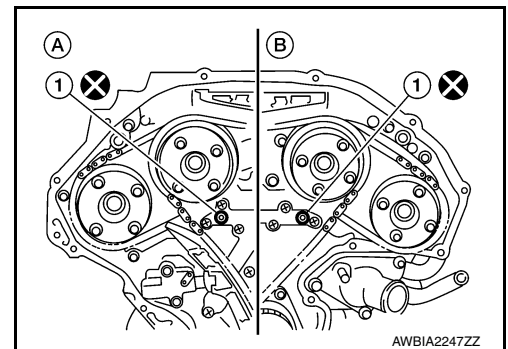

FRONT TIMING CHAIN CASE

< REMOVAL AND INSTALLATION >

5. Apply Silicone RTV Sealant to front timing chain case as shown.
 - Use Genuine Silicone RTV Sealant, or equivalent. Refer to [GI-22. "Recommended Chemical Products and Sealants"](#).
 - Before installation, wipe off the protruding sealant.
 - (C): 2.6 - 3.6 mm (0.102 - 0.142 in) dia.

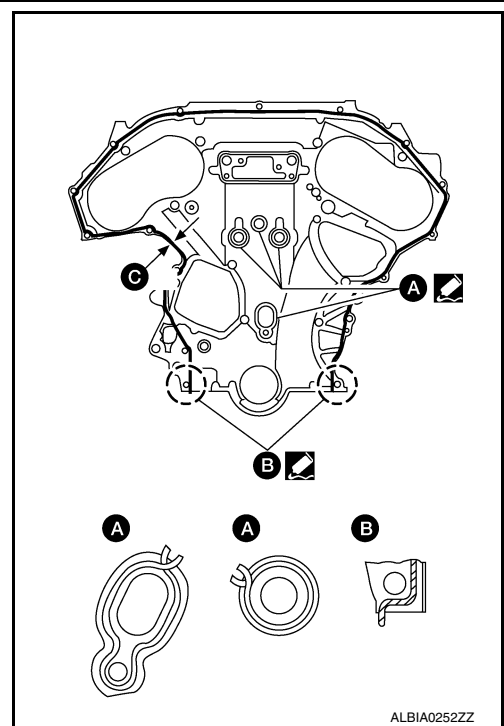

6. Install dowel pin on the front timing chain case into dowel pin hole in the rear timing chain case.
7. Loosely install the front timing chain case bolts.

Bolt position	Bolt diameter
1, 2	: 8 mm (0.31 in)
3 – 22	: 6 mm (0.24 in)

8. Tighten the front timing chain case bolts in the order as shown.
 - Retighten the front timing chain case bolts in the order as shown.

Bolt position	Tightening specification
1, 2	: 28.4 N·m (2.9 kg-m, 21 ft-lb)
3 – 22	: 12.7 N·m (1.3 kg-m, 9 ft-lb)

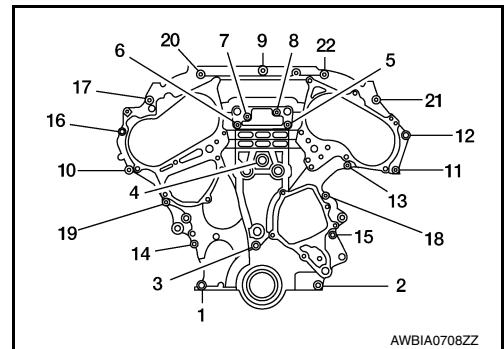

9. Install upper oil pan bolts (1) and (2) as shown. Refer to [EM-40. "Removal and Installation \(Upper Oil Pan\)"](#).

⇐ :Front

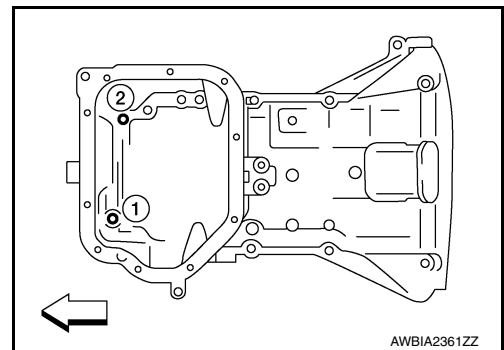

10. Install lower oil pan. Refer to [EM-39. "Removal and Installation \(Lower Oil Pan\)"](#).
11. Install intake valve timing control solenoid valve covers as follows:
 - a. Install new O-rings in shaft grooves.

CAUTION:
Do not reuse O-rings.
 - b. Being careful not to move O-rings from the installation grooves, align dowel pins on front timing chain case with the holes to install valve timing control covers.

FRONT TIMING CHAIN CASE

< REMOVAL AND INSTALLATION >

- c. Tighten intake valve timing control solenoid valve cover bolts in numerical order as shown.

- (A) : Bank 1 (RH)
(B) : Bank 2 (LH)
(C) : Dowel pin hole

Intake valve timing control solenoid valve cover bolts : 11.3 N·m (1.2 kg-m, 8 ft-lb)

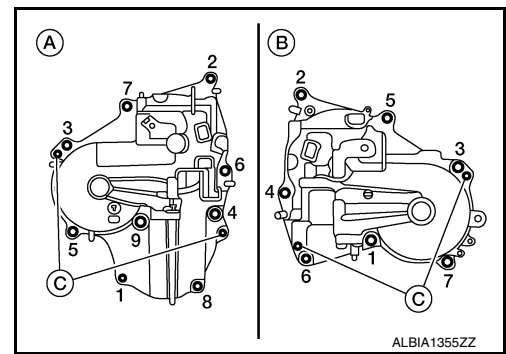

12. Apply liquid gasket and install the water pump cover, if removed.
- Use Genuine Silicone RTV Sealant or equivalent. Refer to [GI-22. "Recommended Chemical Products and Sealants"](#).
13. Install crankshaft pulley (A) and tighten the bolt in two steps.
- Lubricate thread and seat surface of the bolt with new engine oil.
 - Apply a paint mark for the second step of angle tightening.

Step 1 : 44 N·m (4.5 kg-m, 32 ft-lb)
Step 2 : 84° - 90° degrees clockwise

Tool Number : KV10112100 (BT-8653-A)

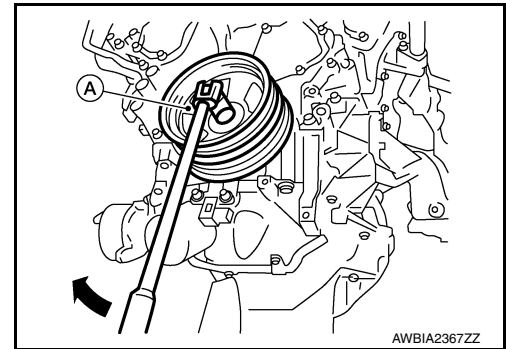

14. Remove Tool and install the access plate.

Tool number : — (J-50288)

CAUTION:

Do not damage the ring gear teeth, or the signal plate teeth behind the ring gear, when removing the Tool.

15. Rotate crankshaft pulley in normal direction (clockwise when viewed from front) to confirm it turns smoothly.
16. Installation of the remaining components is in the reverse order of removal.

INSPECTION AFTER INSTALLATION

- Before starting engine, check oil/fluid levels including engine coolant and engine oil. If there is less than required quantity, fill to the specified level. Refer to [MA-16. "FOR USA AND CANADA : Fluids and Lubricants"](#) or [MA-17. "FOR MEXICO : Fluids and Lubricants"](#).
- Use procedure below to check for fuel leaks.
- Turn ignition switch ON (with engine stopped). With fuel pressure applied to fuel piping, check for fuel leaks at connection points.
- Start engine. With engine speed increased, check again for fuel leaks at connection points.
- Run engine to check for unusual noise and vibration.

NOTE:

- If hydraulic pressure inside timing chain tensioner drops after removal and installation, slack in the guide may generate a pounding noise during and just after engine start. However, this is normal. Noise will stop after hydraulic pressure rises.
- Warm up engine thoroughly to make sure there is no leaks of fuel, exhaust gas, or any oils/fluids including engine oil and engine coolant.
 - Bleed air from passages in lines and hoses, such as in cooling system.
 - After cooling down engine, again check oil/fluid levels including engine oil and engine coolant. Refill to specified level, if necessary.
 - Summary of the inspection items:

FRONT TIMING CHAIN CASE

< REMOVAL AND INSTALLATION >

Item	Before starting engine	Engine running	After engine stopped		
Engine coolant	Level	leaks	Level	A	
Engine oil	Level	leaks	Level		
Transmission/ transaxle fluid	A/T and CVT Models	leaks	Level/leaks	leaks	EM
	M/T Models	Level/leaks	level/leaks	Level/leaks	
Other oils and fluids*	Level	leaks	Level	C	
Fuel	leaks	leaks	leaks		
Exhaust gas	—	leaks	—	D	

*Power steering fluid, brake fluid, etc.

E
F
G
H
I
J
K
L
M
N
O
P

TIMING CHAIN

< REMOVAL AND INSTALLATION >

TIMING CHAIN

Exploded View

INFOID:000000012232195

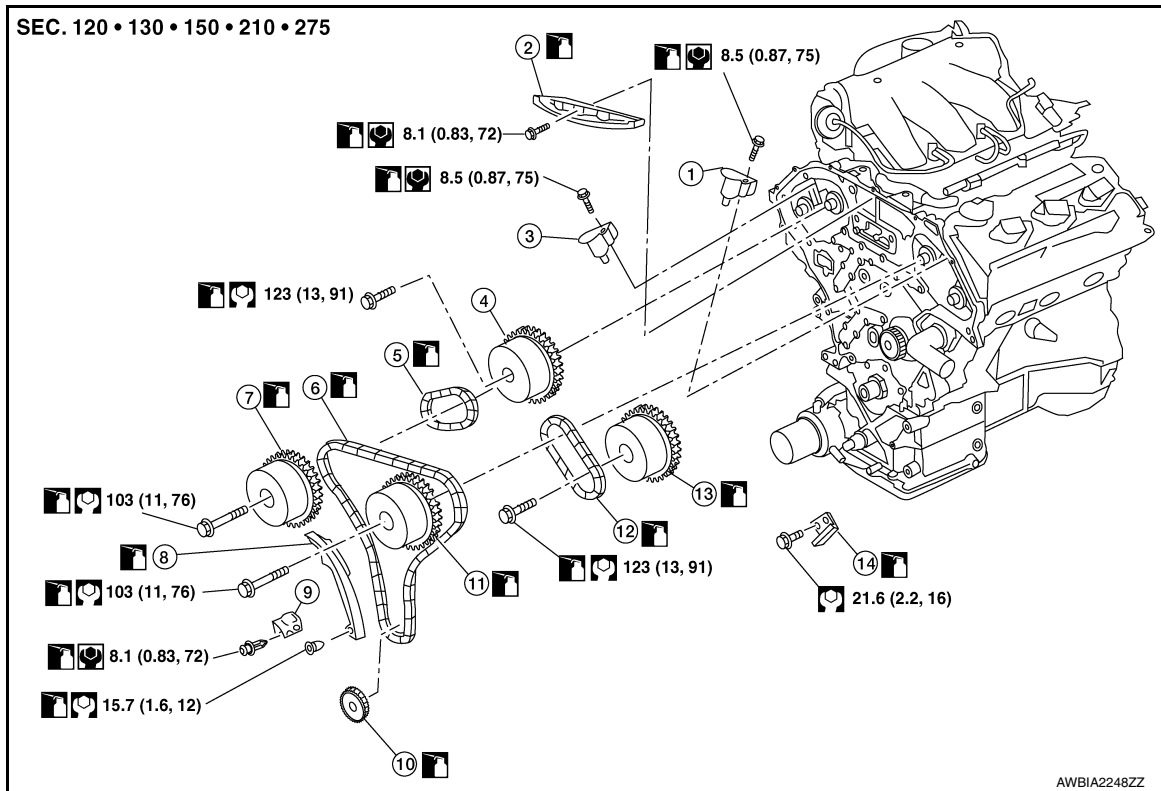

- | | | |
|--|--------------------------------------|--|
| 1. Timing chain tensioner (secondary) (bank 2) | 2. Internal chain guide | 3. Timing chain tensioner (secondary) (bank 1) |
| 4. Camshaft sprocket (bank 1) (EXH) | 5. Timing chain (secondary) | 6. Timing chain (primary) |
| 7. Camshaft sprocket (bank 1) (INT) | 8. Slack guide | 9. Timing chain tensioner (primary) |
| 10. Crankshaft sprocket | 11. Camshaft sprocket (bank 2) (INT) | 12. Timing chain (secondary) (INT) |
| 13. Camshaft sprocket (bank 2) (EXH) | 14. Tension guide | |

Removal and Installation

INFOID:000000012232196

CAUTION:

- After removing timing chains, do not turn the crankshaft and camshaft separately or the valves will strike the pistons.
- When installing camshafts, chain tensioners, oil seals, or other sliding parts, lubricate contacting surfaces with new engine oil.
- Apply new engine oil to bolt threads and seat surfaces when installing camshaft sprockets, camshaft brackets, and crankshaft pulley.

REMOVAL

1. Remove front timing chain case. Refer to [EM-58, "Removal and Installation"](#).
2. Remove the intake manifold collector. Refer to [EM-27, "Removal and Installation"](#).
3. Remove the spark plugs. Refer to [EM-14, "Removal and Installation"](#).
4. Place paint marks on the timing chain and sprockets to indicate the correct position of the components for installation.
5. Disconnect the camshaft position sensor harness connectors.
6. Remove the timing chain tensioner (primary).

TIMING CHAIN

< REMOVAL AND INSTALLATION >

- a. Pull lever (D) down and release plunger stopper tab (A). Plunger stopper tab can be pushed up to release (coaxial structure with lever).

(B) : Timing chain tensioner (primary)

(C) : Stopper pin

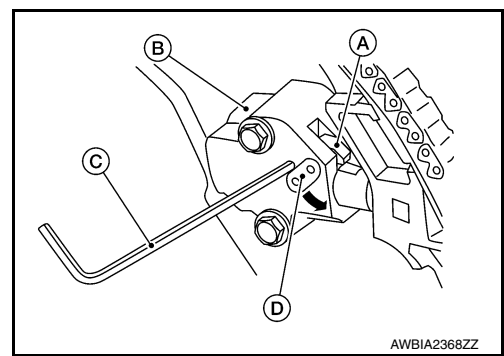

- b. Insert stopper pin (D) into timing chain tensioner (primary) body hole to hold lever, and keep the tab released. An Allen wrench [1.2 mm (0.047 in)] is used for a stopper pin (D) as an example.
- c. Insert plunger (A) into tensioner body by pressing the slack guide (B).
- d. Keep the slack guide (B) pressed and hold it by pushing the stopper pin (D) through the lever hole and body hole.
- e. Remove the bolts (C) and remove the timing chain tensioner (primary).

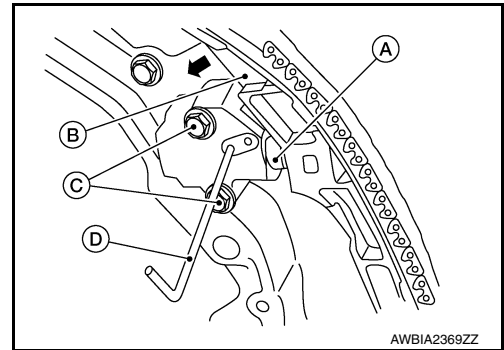

7. Remove internal chain guide (A), tension guide (C) and slack guide (B).

NOTE:

Tension guide can be removed after removing timing chain (primary).

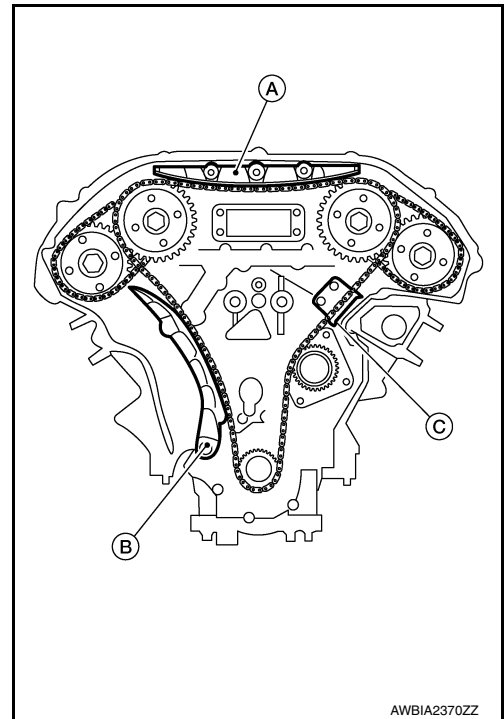

8. Remove timing chain (primary) and crankshaft sprocket.

CAUTION:

After removing timing chains, do not turn the crankshaft and camshaft separately or the valves will strike the pistons.

9. Remove timing chain (secondary) and camshaft sprockets as follows:

TIMING CHAIN

< REMOVAL AND INSTALLATION >

- a. Attach a suitable stopper pin (B) to the timing chain tensioner [secondary (bank 1)] (1) and timing chain tensioner [secondary (bank 2)] (2).

NOTE:

- Use approximately 0.5 mm (0.02 in) diameter hard metal pin as a stopper pin.
- Removal of camshaft bracket (No. 1) is required prior to removing the timing chain tensioner (secondary).

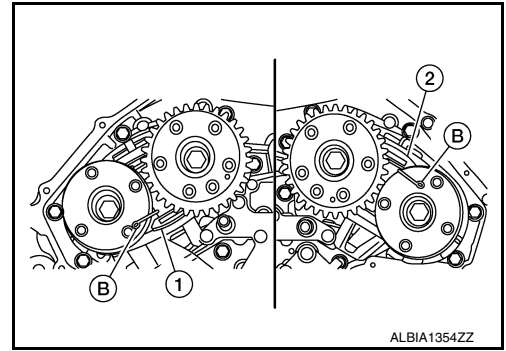

- b. Remove camshaft sprockets (INT/EXH) bolts.
- Secure the hexagonal portion of camshaft using a suitable tool to loosen bolts.

CAUTION:

Do not loosen bolts using anything other than the camshaft hexagonal portion. Do not apply tension to the timing chain.

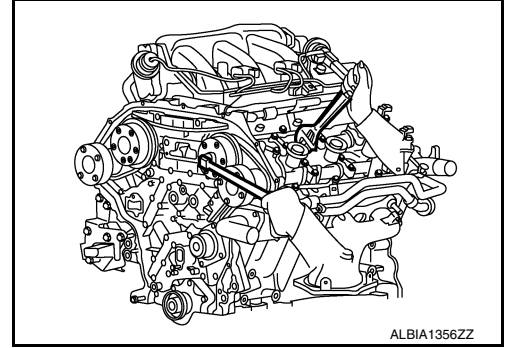

- c. Remove timing chain (secondary) together with camshaft sprockets.
- Turn camshaft slightly to keep the chain tight when removing the timing chain (secondary).
 - Insert 0.5 mm (0.020 in) thick metal or resin plate between timing chain and timing chain tensioner plunger (guide) (E). Remove timing chain (secondary) (2) together with camshaft sprockets with timing chain loose from guide groove.

- (1) : Timing chain tensioner (secondary)
- (A) : Bank 1 (RH)
- (B) : View B
- (C) : Stopper pin
- (D) : Plate
- (F) : Timing chain tensioner (body)

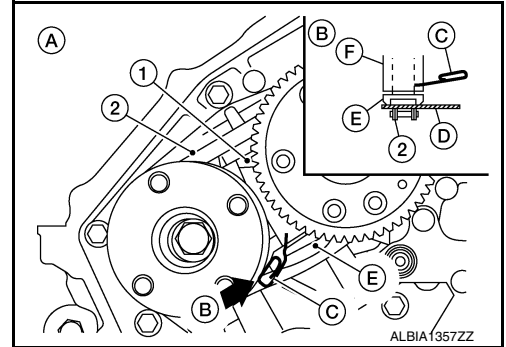

CAUTION:

Be careful of plunger coming off when removing timing chain (secondary). The plunger of timing chain tensioner (secondary) moves during operation, which could cause the stopper pin to fall out.

- Bank 1 shown.

- d. Camshaft sprocket (INT) is two-for-one structure of sprockets for timing chain (primary) and for timing chain (secondary).

CAUTION:

- Handle camshaft sprocket (INT) carefully to avoid any shock to camshaft sprocket.
- Do not disassemble. [Do not loosen bolts (A) as shown].

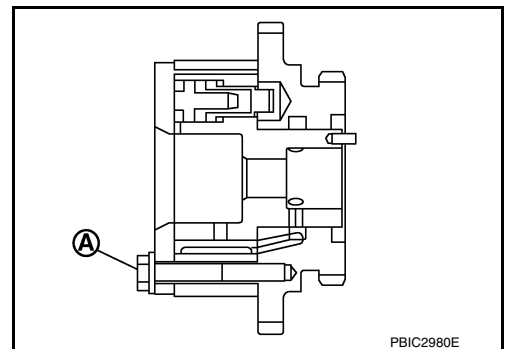

INSPECTION

TIMING CHAIN

< REMOVAL AND INSTALLATION >

Check for cracks and any excessive wear of the timing chain. Replace the timing chain as necessary.

INSTALLATION

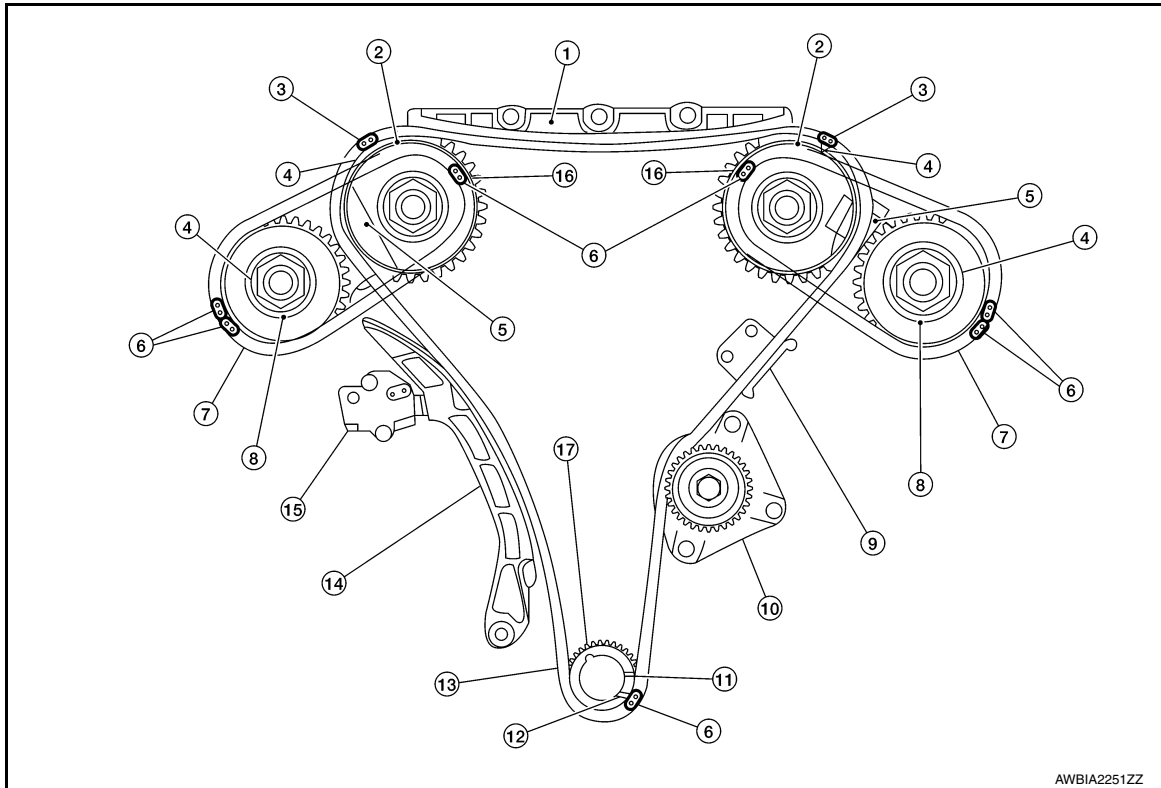

- | | | |
|-----------------------------|---------------------------------------|--------------------------------------|
| 1. Internal chain guide | 2. Camshaft sprocket (INT) | 3. Mating mark (pink link) |
| 4. Mating mark (punched) | 5. Timing chain tensioner (secondary) | 6. Mating mark (orange link) |
| 7. Timing chain (secondary) | 8. Camshaft sprocket (EXH) | 9. Tension guide |
| 10. Water pump | 11. Crankshaft sprocket | 12. Mating mark (notched) |
| 13. Timing chain (primary) | 14. Slack guide | 15. Timing chain tensioner (primary) |
| 16. Mating mark (back side) | 17. Crankshaft key | |

NOTE:

This illustration shows the relationship between the mating mark on each timing chain and on the corresponding sprocket with the components installed.

1. Install timing chain tensioners (secondary) with a new O-ring and the stopper pin attached.

CAUTION:

Do not reuse O-ring.

2. Check that dowel pin (A) and crankshaft key (1) are located as shown. (No. 1 cylinder at compression TDC)

NOTE:

Though camshaft does not stop at the position as shown, for the placement of cam nose, it is generally accepted camshaft is placed in the same direction.

Camshaft dowel pin

: At cylinder head upper face side in each bank

Crankshaft key

: At cylinder head side of bank 1

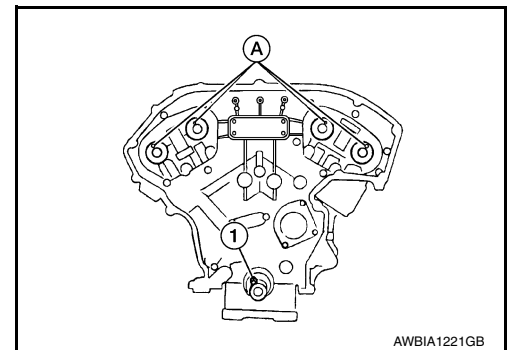

3. Install timing chain (secondary) and camshaft sprockets (INT and EXH) as follows:

CAUTION:

Mating marks between timing chain and sprockets slip easily. Confirm all mating mark positions repeatedly during the installation process.

TIMING CHAIN

< REMOVAL AND INSTALLATION >

- a. Push plunger of timing chain tensioner (secondary) and keep it pressed in with stopper pin (A).

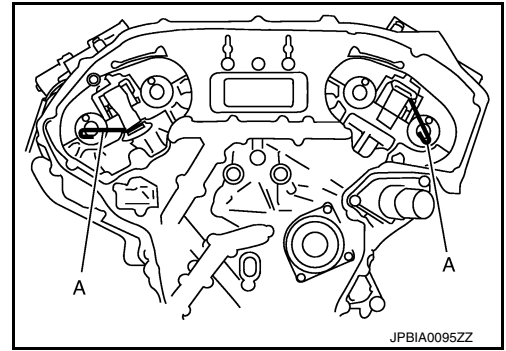

- b. Install timing chain (secondary) (2) and camshaft sprockets [INT (1) and EXH (3)].

- (A) : Bank 1
- (B) : Bank 2
- (C) : Chain timing mark (oblong hole)
- (D) : Dowel pin groove
- (E) : Orange link
- (F) : Chain timing mark (circle hole)

- Align the mating marks on timing chain (secondary) (orange link) with the mating marks on camshaft sprockets (INT and EXH), and install them.
- Align dowel pin on camshafts with the groove on sprockets, and install them.
- Tighten the bolts for the camshaft sprockets by hand enough to prevent the dowel pins from falling out of the grooves.

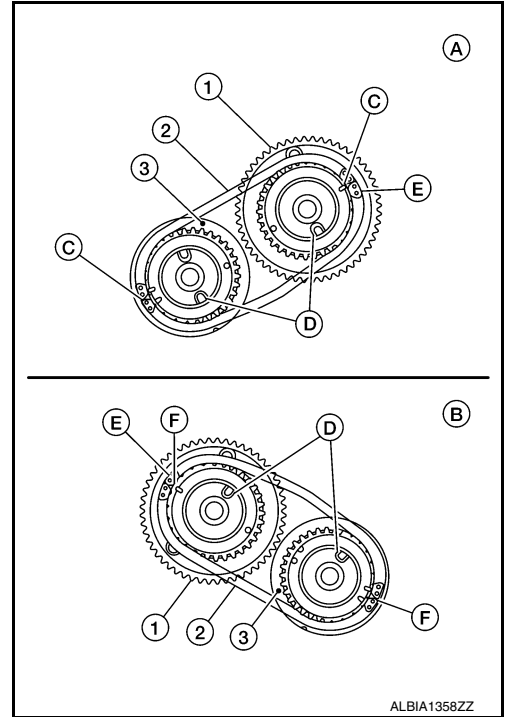

- It may be difficult to visually check the dislocation of mating marks during and after installation. To make the matching easier, make a mating mark (A) on the top of sprocket teeth and its extended line with paint.

- (B) : Mating mark (orange link)

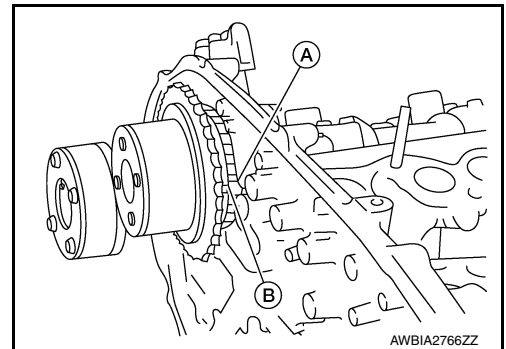

4. After confirming the mating marks are aligned, tighten the camshaft sprocket bolts.
- Secure the camshaft using a wrench at the hexagonal portion to tighten the bolts.

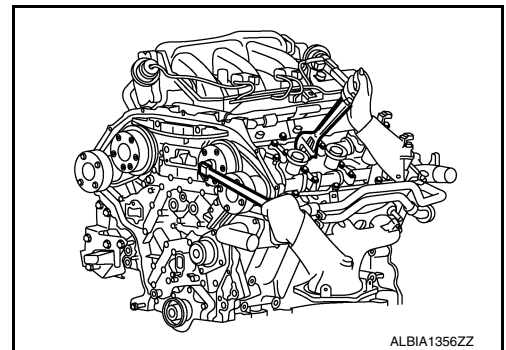

TIMING CHAIN

< REMOVAL AND INSTALLATION >

5. Pull stopper pins (B) out from timing chain tensioner [secondary (bank 1)] (1) and timing chain tensioner [secondary (bank 2)] (2).

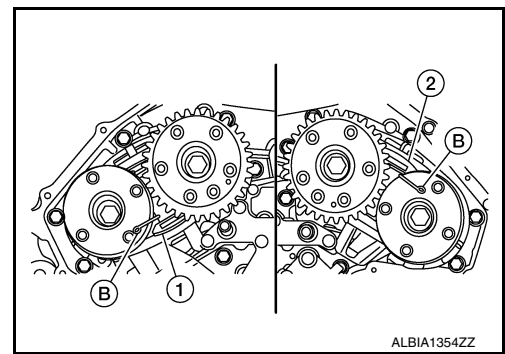

6. Install the crankshaft sprocket (C) on the crankshaft.
- Make sure the mating marks (D) on the crankshaft sprocket (C) face the front of the engine (B).
 - The flat side of the crankshaft sprocket (C) is on the crankshaft side (A).

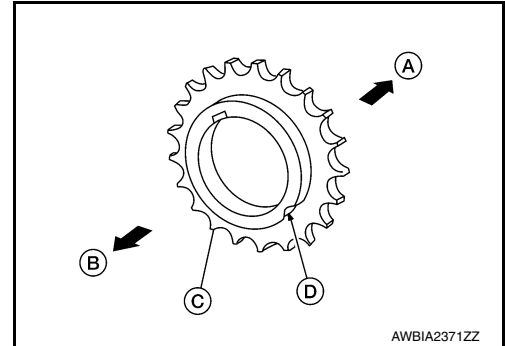

7. Install the timing chain (primary).
- Install timing chain (primary) so the mating mark (punched) (B) on camshaft sprocket (C) is aligned with the pink link (A) on the timing chain, while the mating mark (notched) (E) on the crankshaft sprocket (D) is aligned with the orange one (F) on the timing chain, as shown.
 - When it is difficult to align mating marks of the timing chain (primary) with each sprocket, gradually turn the camshaft using a wrench on the hexagonal portion to align it with the mating marks.
 - During alignment, be careful to prevent dislocation of mating mark alignments of the secondary timing chains.

(G) : Water pump

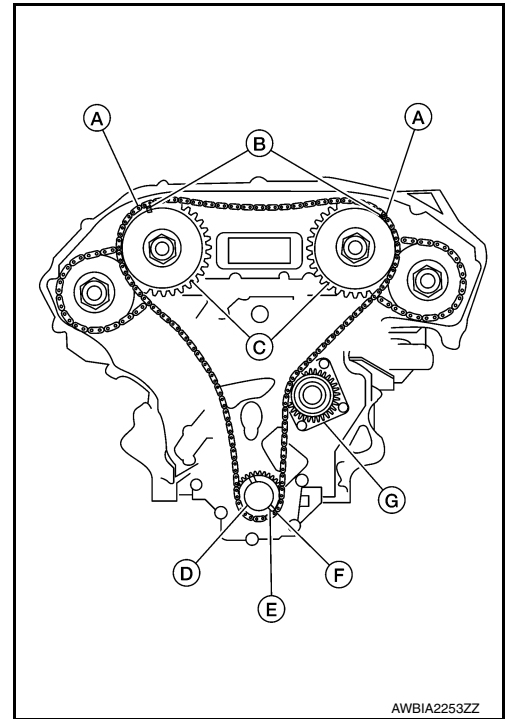

TIMING CHAIN

< REMOVAL AND INSTALLATION >

8. Install the internal chain guide (1) and slack guide (2).

(3) : Tension guide

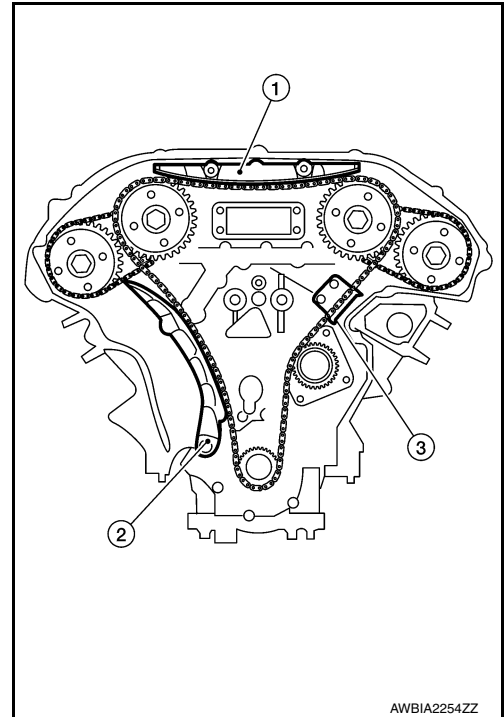

CAUTION:

Do not over tighten slack guide mounting bolt (2). It is normal for a gap (A) to exist under the bolt seat when bolt is tightened to specification.

(1) : Slack guide
(3) : Cylinder block

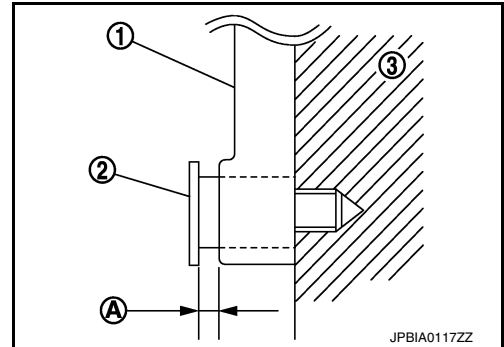

9. Install the timing chain tensioner (primary) with the following procedure:

- Pull plunger stopper tab (A) up (or turn lever downward) so as to remove plunger stopper tab from the ratchet of plunger (D).

NOTE:

Plunger stopper tab and lever (C) are synchronized.

- Push plunger into the inside of tensioner body.
- Hold plunger in the fully compressed position by engaging plunger stopper tab with the tip of ratchet.
- To secure lever, insert stopper pin (E) through hole of lever into tensioner body hole (B).

 - The lever parts and the tab are synchronized. Therefore, the plunger will be secured under this condition.

NOTE:

Illustration shows the example of 1.2 mm (0.047 in) diameter thin screwdriver being used as the stopper pin.

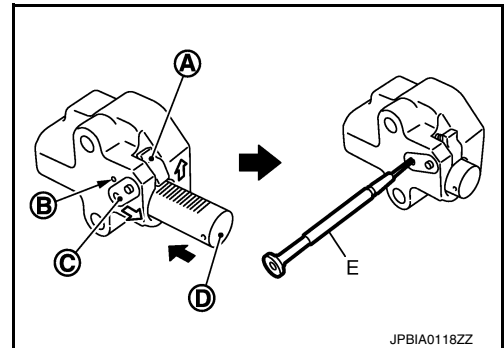

TIMING CHAIN

< REMOVAL AND INSTALLATION >

- e. Install timing chain tensioner (primary) (1).
 - Remove any dirt and foreign materials completely from the back and the mounting surfaces of timing chain tensioner (primary).
- f. Pull out stopper pin (A) after installing, and then release plunger.

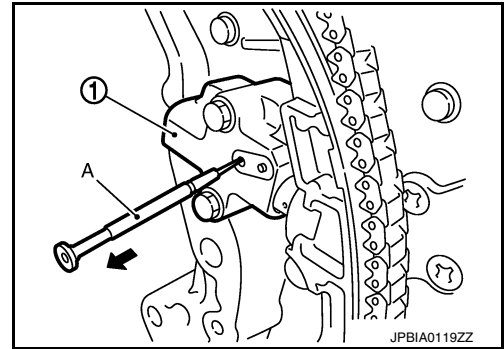

10. Reconfirm that the matching marks on the sprockets and the timing chain have not slipped out of alignment.
11. Install the spark plugs. Refer to [EM-14, "Removal and Installation"](#).
12. Install the intake manifold collector. Refer to [EM-27, "Removal and Installation"](#).
13. Install the front timing chain case. Refer to [EM-58, "Removal and Installation"](#).

REAR TIMING CHAIN CASE

< REMOVAL AND INSTALLATION >

REAR TIMING CHAIN CASE

Exploded View

INFOID:000000012232197

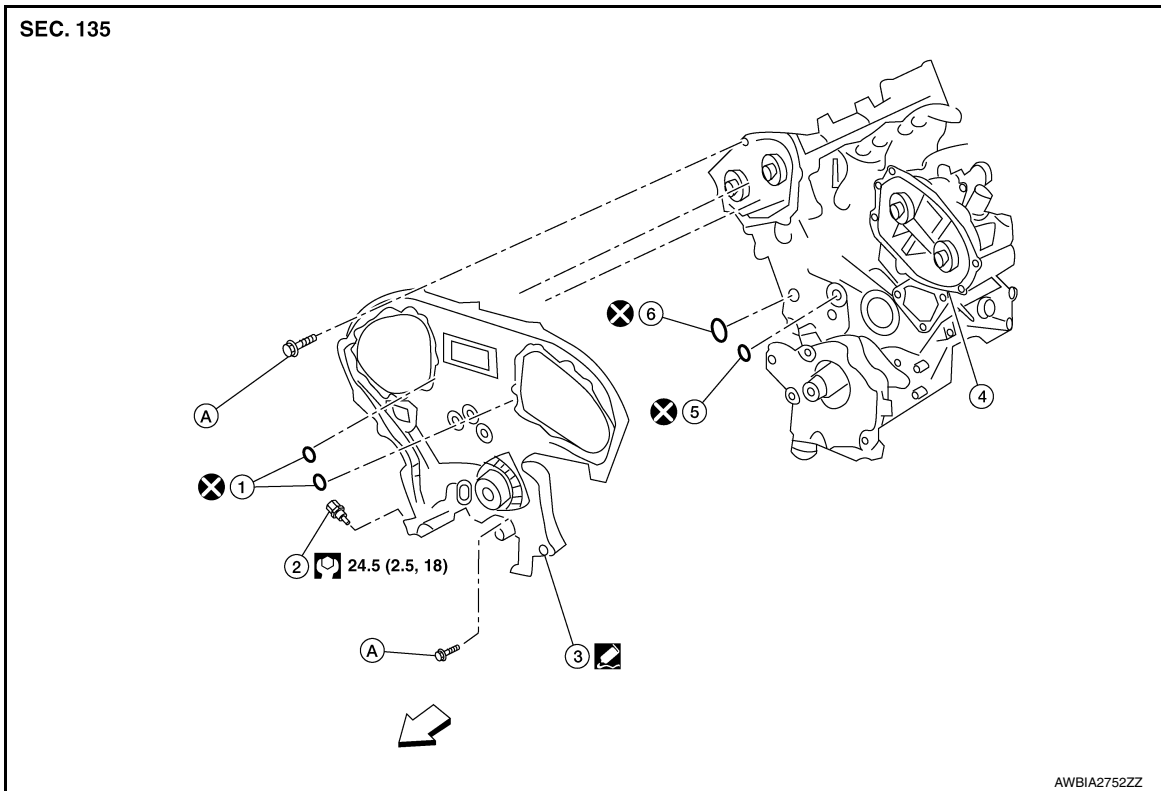

- | | | |
|--------------------------|---------------------------|---------------------------|
| 1. O-ring | 2. Oil temperature sensor | 3. Rear timing chain case |
| 4. Cylinder block | 5. O-ring | 6. O-ring |
| A. Refer to INSTALLATION | ↶ Engine front | |

Removal and Installation

INFOID:000000012232198

CAUTION:

- After removing timing chain, do not turn the crankshaft and camshaft separately, or the valves will strike the pistons.
- Before removing the upper oil pan, remove the crankshaft position sensor (POS).
- Be careful not to damage sensor edges.

REMOVAL

1. Remove the engine assembly. Refer to [EM-107, "Removal and Installation"](#).
2. Remove upper oil pan. Refer to [EM-40, "Removal and Installation \(Upper Oil Pan\)"](#).
3. Remove the front timing chain case. Refer to [EM-58, "Removal and Installation"](#).
4. Remove the timing chains (primary) and (secondary). Refer to [EM-66, "Exploded View"](#).

REAR TIMING CHAIN CASE

< REMOVAL AND INSTALLATION >

5. Remove the rear timing chain case.

CAUTION:

- Do not remove the plate metal cover for the oil passage.
- After removing the chain case, do not apply any load to the case that might bend it.

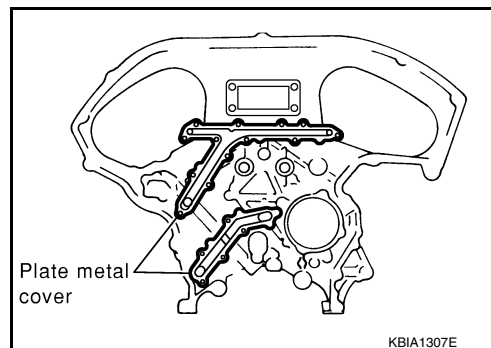

- a. Loosen and remove the rear timing chain case bolts in the reverse order shown.

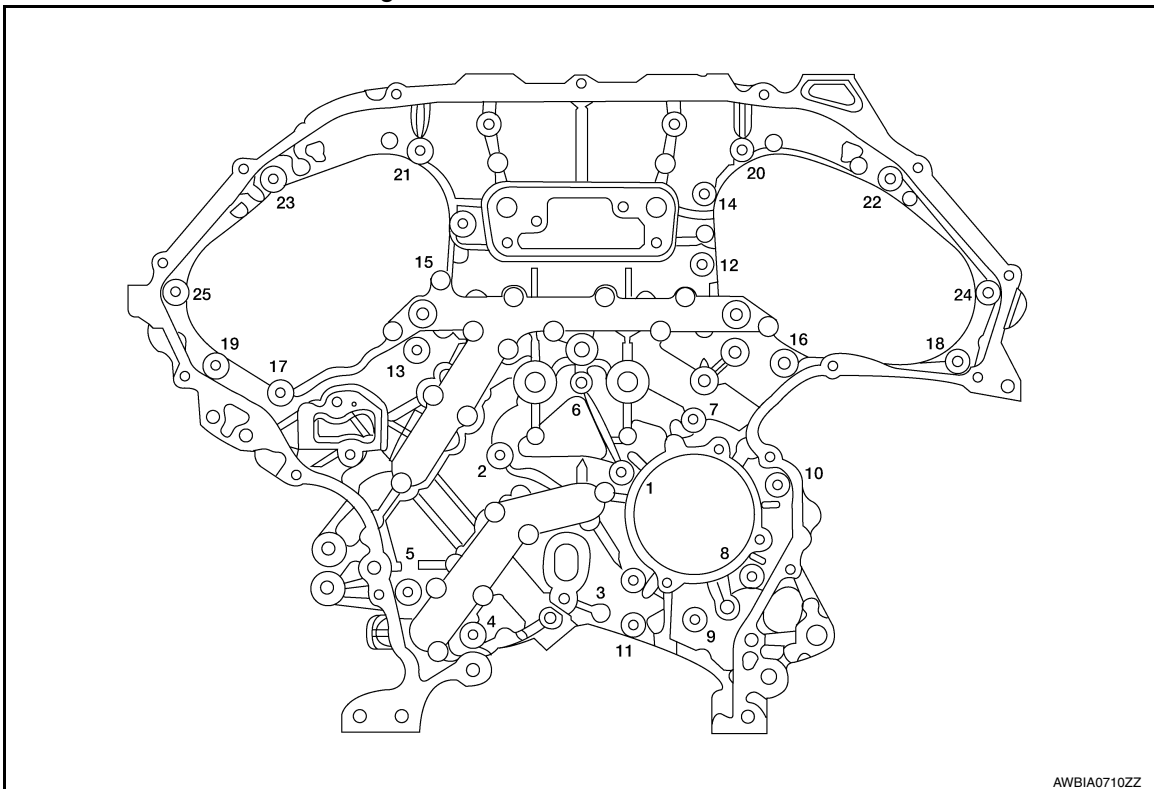

- b. Cut the sealant using Tool and remove the rear timing chain case.

- After removing the bolts, separate the mating surface and remove the old liquid gasket using Tool.

Tool number : KV10111100 (J-37228)

CAUTION:

Do not damage the mating surfaces.

- Tap the seal cutter to insert it (1).
- In areas where the Tool is difficult to use, lightly tap to slide it (2).

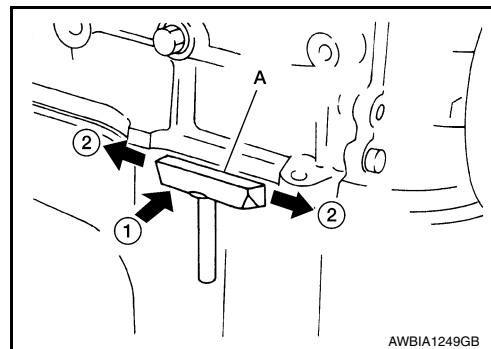

REAR TIMING CHAIN CASE

< REMOVAL AND INSTALLATION >

6. Remove O-rings (1) from cylinder block.

⇐ : Engine front

CAUTION:
Do not reuse O-rings.

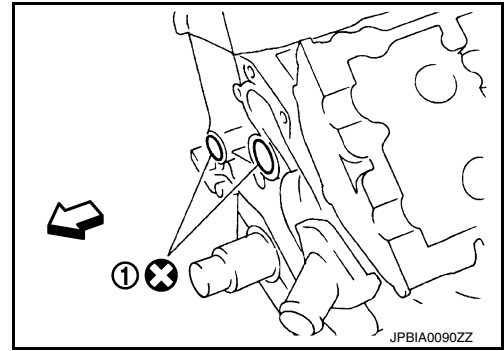

7. Use a scraper (A) to remove all of the old Silicone RTV Sealant from the front and rear timing chain case (B) and opposite mating surfaces.

CAUTION:
Do not damage the mating surfaces.

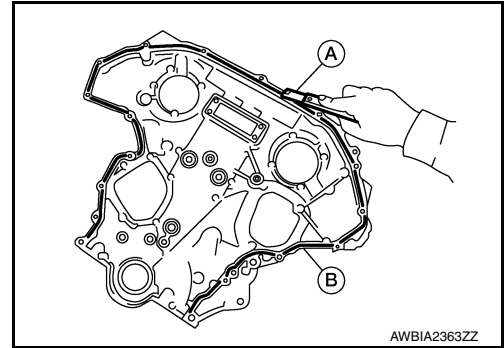

8. Remove all old Silicone RTV Sealant (A) from all the bolt holes (B) and threads.

CAUTION:
Do not damage the threads or mating surfaces.

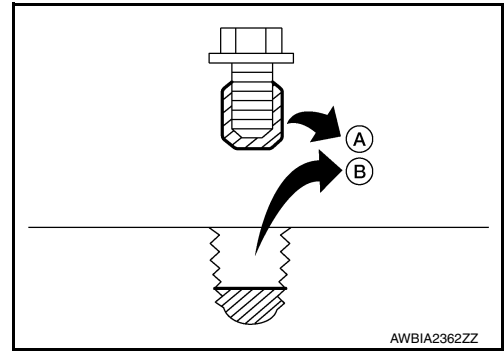

INSTALLATION

1. Install O-rings (1) on cylinder block.

⇐ : Engine front

CAUTION:
Do not reuse O-rings.

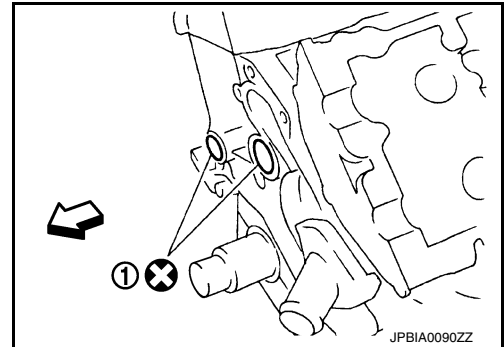

2. Apply Genuine Silicone RTV Sealant or equivalent, to the rear timing chain case using suitable tool as shown. Refer to [GI-22, "Recommended Chemical Products and Sealants"](#).

CAUTION:

- Installation should be done within 5 minutes after applying liquid gasket.
- Do not fill the engine with oil for at least 30 minutes after the components are installed to allow the sealant to cure.
- Wipe off liquid gasket where it touches the engine coolant passage at point "a".
- Follow the installation instructions for applying the liquid gasket. Pay particular attention to the water pump and cylinder area.

REAR TIMING CHAIN CASE

< REMOVAL AND INSTALLATION >

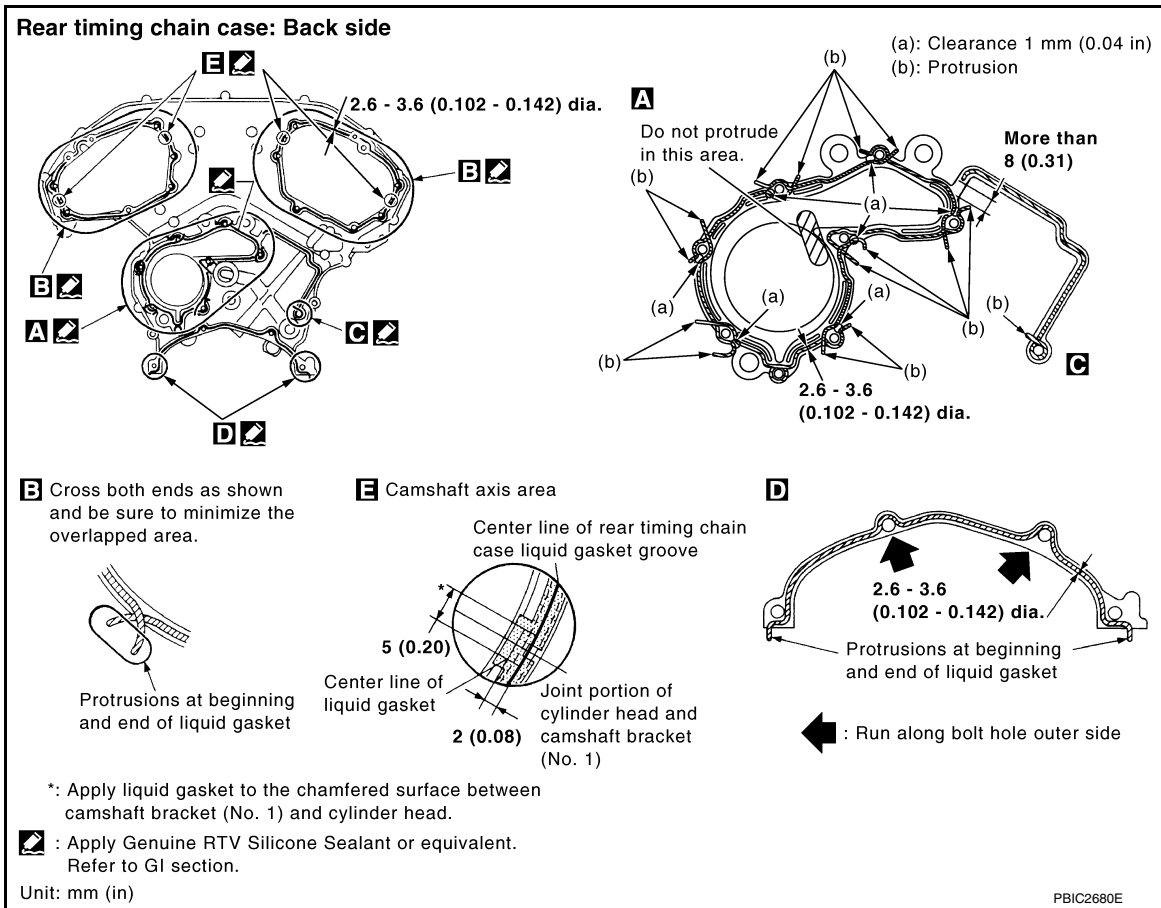

3. Align the rear timing chain case and water pump assembly with the dowel pins (RH/LH) on the cylinder block and install the case. Make sure the O-rings stay in place during installation.
 - a. Tighten the bolts in the numerical order as shown. There are two bolt lengths used. Follow the chart below for proper bolt length specifications.

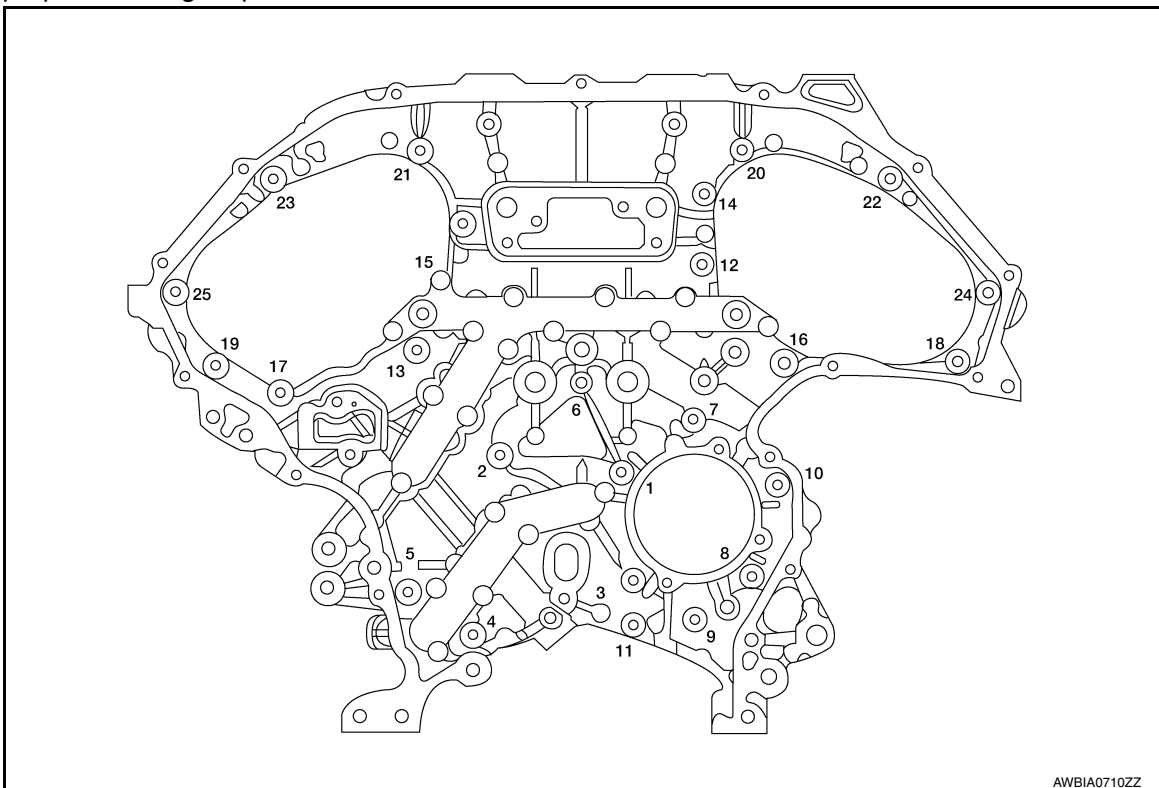

REAR TIMING CHAIN CASE

< REMOVAL AND INSTALLATION >

Bolt length	Bolt position	Torque specification
20 mm (0.79 in)	1, 2, 3, 6, 7, 8, 9, 10	12.7 N·m (1.3 kg-m, 9 ft-lb)
16 mm (0.63 in)	All except the above	12.7 N·m (1.3 kg-m, 9 ft-lb)

- b. After all bolts are initially tightened, retighten them to the specification in the numerical order as shown.

NOTE:

If liquid gasket protrudes, wipe it off immediately.

4. Install the timing chains (primary and secondary). Refer to [EM-66, "Exploded View"](#).
5. Install the front timing chain case. Refer to [EM-58, "Removal and Installation"](#).
6. Install the upper oil pan. Refer to [EM-40, "Removal and Installation \(Upper Oil Pan\)"](#).
7. Install the engine assembly. Refer to [EM-107, "Removal and Installation"](#).

CAMSHAFT

< REMOVAL AND INSTALLATION >

CAMSHAFT

Exploded View

INFOID:000000011933780

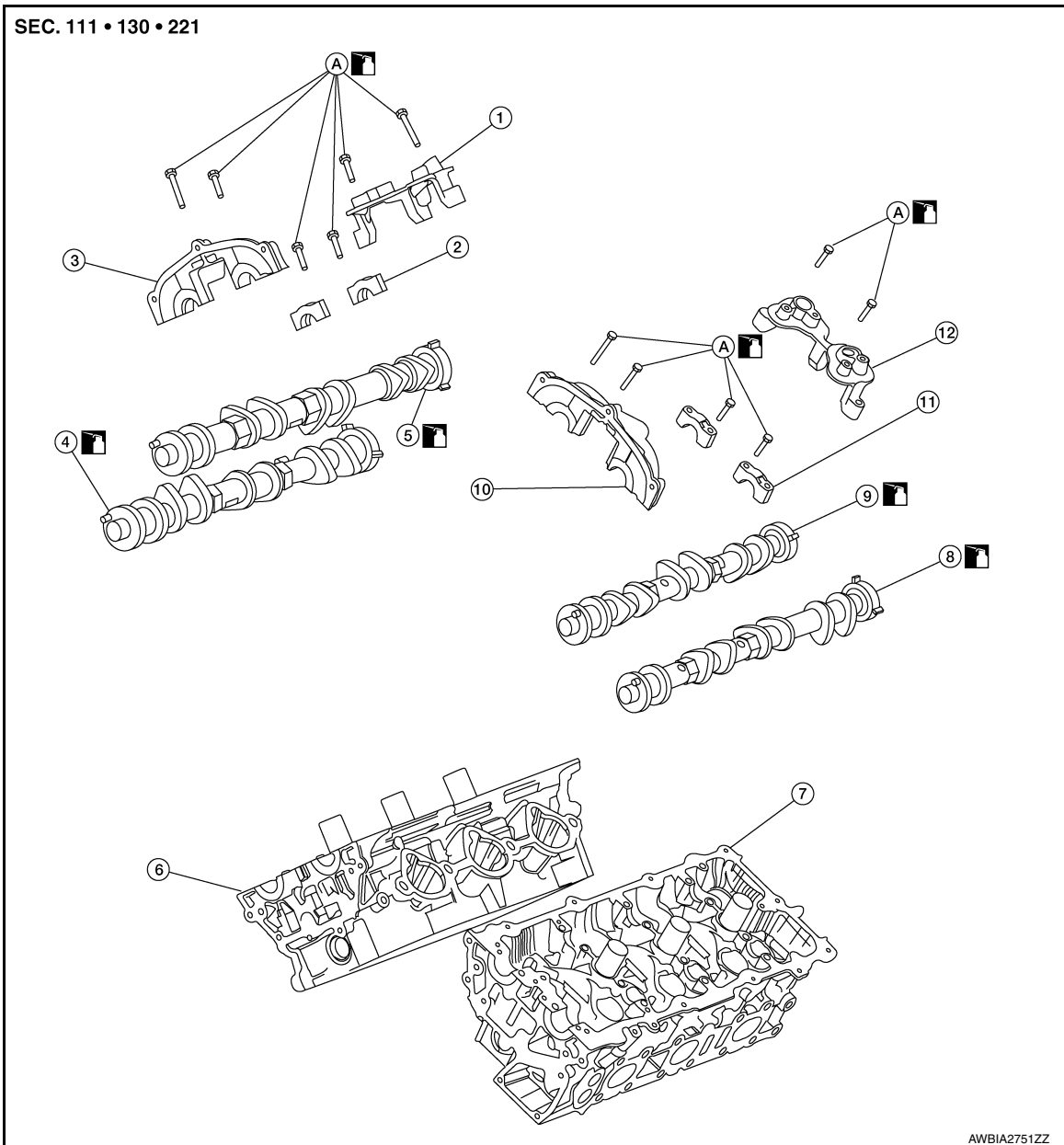

- | | | |
|--|------------------------|---|
| 1. Camshaft position sensor bracket (RH) | 2. Camshaft brackets | 3. No. 1 camshaft bracket (RH) |
| 4. Camshaft (EXH) (RH) | 5. Camshaft (INT) (RH) | 6. Cylinder head (RH) |
| 7. Cylinder head (LH) | 8. Camshaft (EXH) (LH) | 9. Camshaft (INT) (LH) |
| 10. No. 1 camshaft bracket (LH) | 11. Camshaft brackets | 12. Camshaft position sensor bracket (LH) |
| A. Refer to INSTALLATION | | |

CAUTION:

Apply new engine oil to parts marked in illustration before installation.

Removal and Installation

INFOID:000000011933781

REMOVAL

1. Remove the timing chains. Refer to [EM-66. "Removal and Installation"](#).

CAMSHAFT

< REMOVAL AND INSTALLATION >

2. Remove camshaft position brackets (RH shown, LH similar).

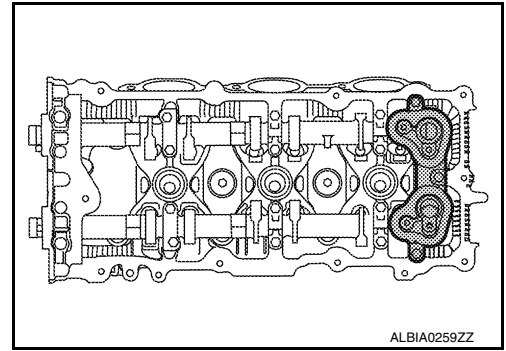

3. Remove the camshaft brackets and the camshafts.

- Mark the camshafts, camshaft brackets, and bolts so they are placed in the same position and direction for installation.
- Equally loosen the camshaft bracket bolts in several steps in the reverse order as shown.

- (1) : Cylinder head (RH)
 (A) : Camshaft (EXH) (RH)
 (B) : Camshaft (INT) (RH)
 (C) : Camshaft bracket
 ⇐ : Engine front

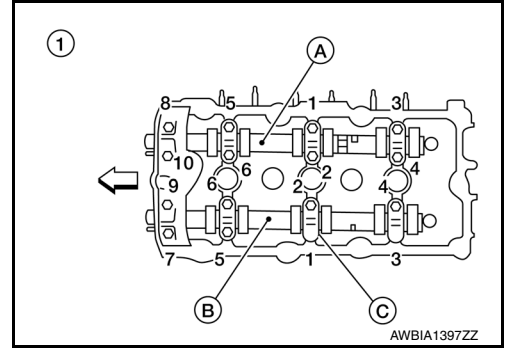

- (2) : Cylinder head (LH)
 (A) : Camshaft (INT) (LH)
 (B) : Camshaft bracket
 (C) : Camshaft (EXH) (LH)
 ⇐ : Engine front

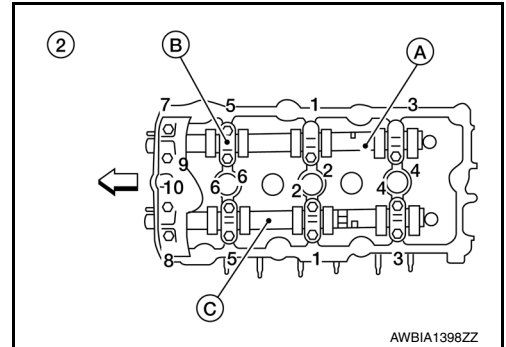

4. Remove valve lifters, if necessary.

NOTE:

Identify installation positions to ensure proper installation.

5. Remove secondary timing chain tensioner (2/5) from bank 1/ bank 2 (A/B)

- Remove secondary tensioner (2/5) with its stopper pin (4) attached.

NOTE:

- Stopper pin (4) was attached when secondary timing chain (2/5) was removed.
- Do not reuse O-rings (1/3).

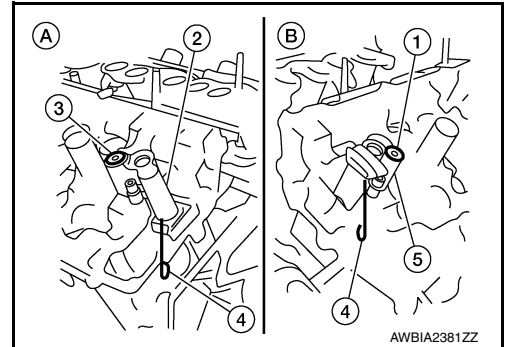

INSTALLATION

CAMSHAFT

< REMOVAL AND INSTALLATION >

1. Before installation, remove any old Silicone RTV Sealant (A) from component mating surfaces using a suitable tool.
 - Remove the old Silicone RTV Sealant (A) from the bolt holes (B) and threads.
 - Do not scratch or damage the mating surfaces.

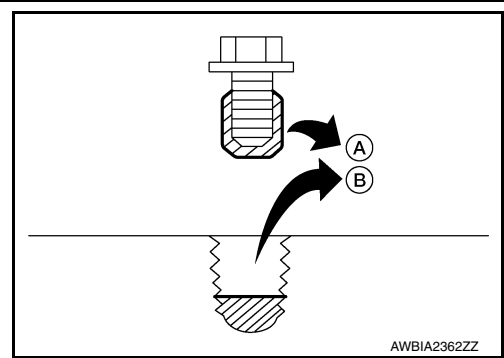

2. Before installing the front cam bracket, remove the old Silicone RTV Sealant (B) from the mating surface using a suitable tool.
 - Do not scratch or damage the mating surface.

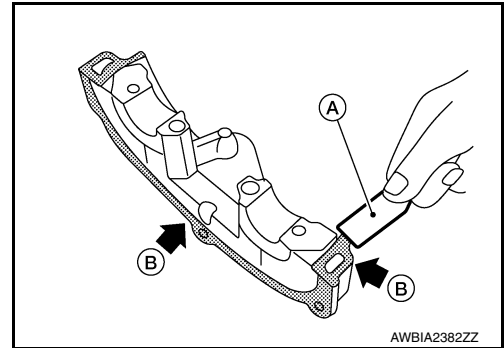

3. Turn the crankshaft until No. 1 piston is set at TDC on the compression stroke.
 - The crankshaft key (A) should line up with the right bank cylinder center line (B) as shown.

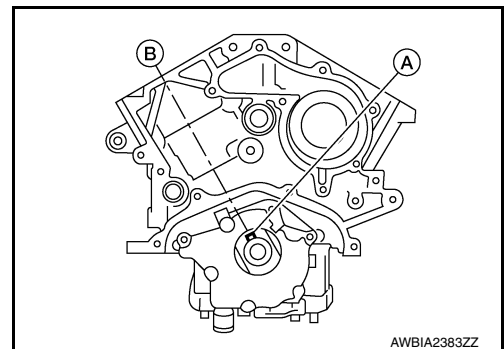

4. Install camshaft chain tensioners (1/2) at bank 1 (A) and bank 2 (B). Refer to [EM-79. "Exploded View"](#).

CAUTION:

Do not reuse O-rings.

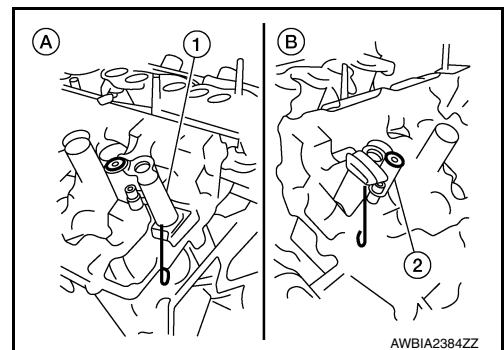

5. Install valve lifters, if removed.

NOTE:
Install them in original positions.
6. Install exhaust camshaft (A) and intake camshaft (B) and camshaft brackets.

CAMSHAFT

< REMOVAL AND INSTALLATION >

- Follow your identification marks made during removal, or follow the identification marks that are present on the new camshafts components for proper placement and direction of the components.

← :Engine front

Bank	INT/EXH	ID mark (A)	Paint marks		
			M1 (E)	M2 (F)	M3 (D)
1 (B)	INT	1A	Purple	No	Light blue
	EXH	1C	No	Brown	Light blue
2 (C)	INT	1B	Purple	No	Light blue
	EXH	1D	No	Brown	Light blue

- Position the camshaft dowel pins (A) as shown.

(1) :Crankshaft key

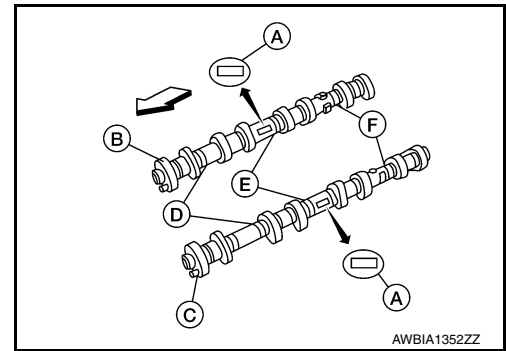

AWBIA1352ZZ

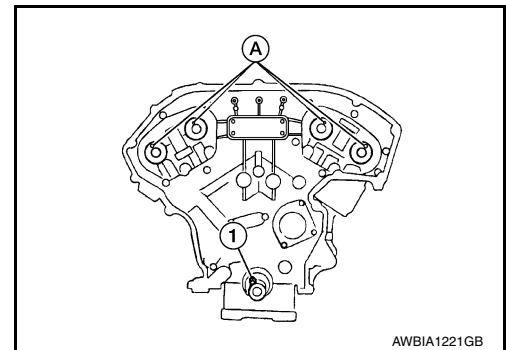

AWBIA1221GB

- Apply sealant to mating surface of camshaft brackets (1) of bank 1 (A) and bank 2 (B) cylinder heads.
 - Use **Genuine Silicone RTV Sealant, or equivalent. Refer to [GI-22, "Recommended Chemical Products and Sealants"](#).**
 - Before installation, wipe off any protruding sealant from front face of camshaft bracket.
 - Refer to [EM-5, "Precaution for Liquid Gasket"](#).

← :Engine front

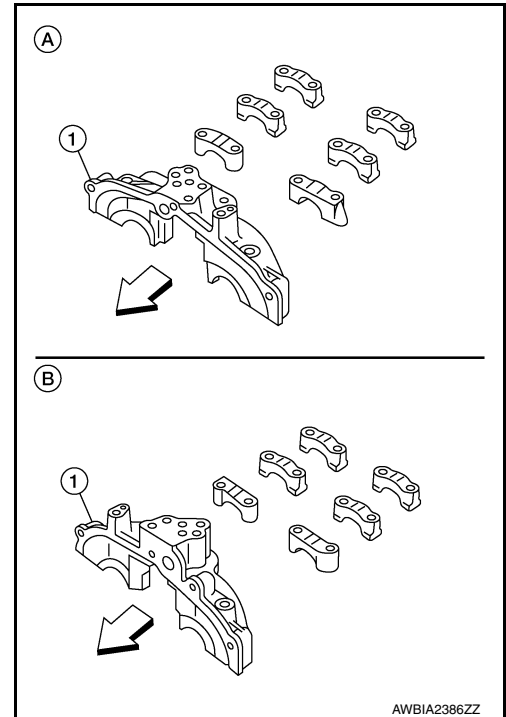

AWBIA2386ZZ

CAMSHAFT

< REMOVAL AND INSTALLATION >

- Install bank 1 (B) and bank 2 (C) camshaft brackets in their original positions and direction. Align the stamp marks (A) as shown.
- **If checking and adjusting any part of valve assembly or camshaft, check valve clearance according to the reference data. Refer to [EM-20, "Valve Clearance"](#).**

← :Engine front

Valve clearance (cold) Intake : 0.26 - 0.34 mm (0.010 - 0.013 in)

Valve clearance (cold) Exhaust : 0.29 - 0.37 mm (0.011 - 0.015 in)

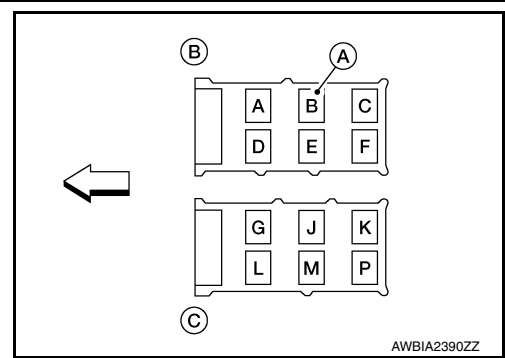

- Locate the camshaft (EXH) (bank 1) (A) and camshaft (INT) (bank 1) (B). Tighten the camshaft brackets (C) in the three steps, in numerical order as shown.

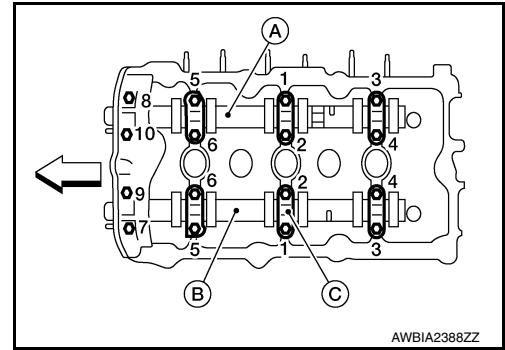

- Locate the camshaft (EXH) (bank 2) (B) and camshaft (INT) (bank 2) (A). Tighten the camshaft brackets (C) in the three steps, in numerical order as shown.

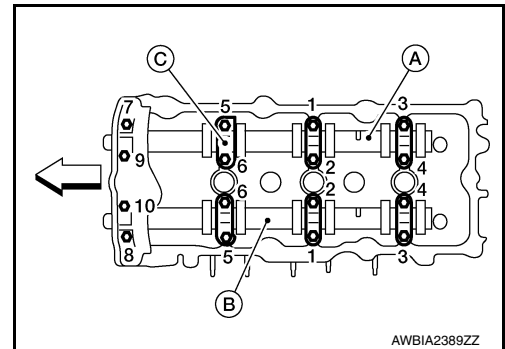

1	1.96 N·m (0.20 kg-m, 17 in-lb)	Tighten No. 7 - 10, then tighten 1 - 6 in numerical order as shown.
2	5.88 N·m (0.60 kg-m, 52 in-lb)	Tighten all in numerical order as shown.
3	10.41 N·m (1.1 kg-m, 8 ft-lb)	Tighten No. 1 - 10 in numerical order as shown.

8. Measure difference in levels between front end faces of No. 1 camshaft bracket and cylinder head.

Standard : - 0.14 (- 0.0055 in)

- If measurement is outside the specified range, reinstall camshaft and camshaft bracket.

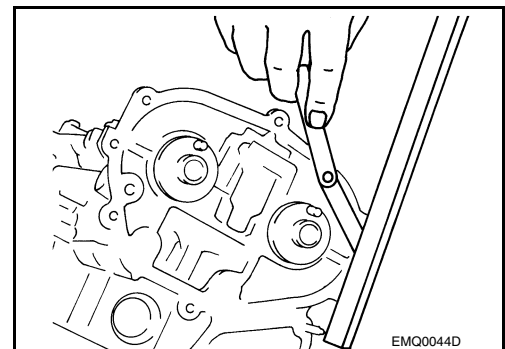

9. Install camshaft position sensor bracket (PHASE) (RH and LH bank.)
10. Install the timing chains. Refer to [EM-66, "Removal and Installation"](#).

INSPECTION AFTER REMOVAL

CAMSHAFT

< REMOVAL AND INSTALLATION >

Camshaft Visual Check

Check camshaft for scratches, seizure and wear. Replace if necessary.

Camshaft Runout

1. Put V-block on precise flat bed and support No. 2 and No. 4 journal of camshaft as shown.
2. Set dial gauges vertically to No. 3 journal as shown.
3. Turn camshaft in one direction slowly by hand, measure the camshaft runout on the dial gauges.
 - Runout is the largest indicator reading after one full revolution. Refer to [EM-140, "Camshaft"](#).
4. If actual runout exceeds the limit, replace the camshaft.

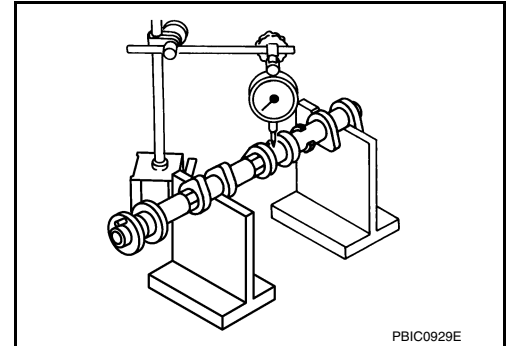

Camshaft Cam Lobe Height

1. Measure camshaft cam lobe height as shown. Refer to [EM-140, "Camshaft"](#).
2. If wear has reduced the lobe height below specifications, replace the camshaft.

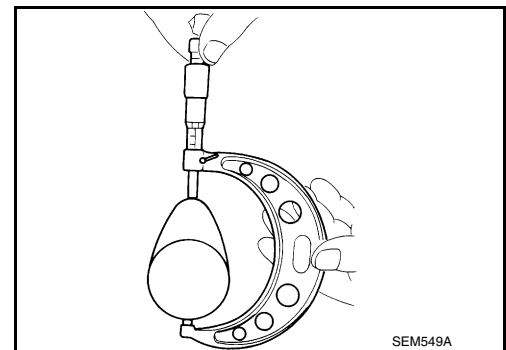

Camshaft Journal Clearance

Outer Diameter of Camshaft Journal

- Measure outer diameter of camshaft journal as shown. Refer to [EM-140, "Camshaft"](#).

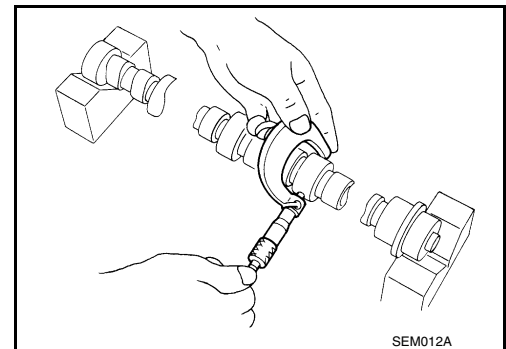

Inner Diameter of Camshaft Bracket

1. Tighten camshaft bracket bolt with specified torque.
2. Using inside micrometer, measure inner diameter (A) of camshaft bearing. Refer to [EM-140, "Camshaft"](#).

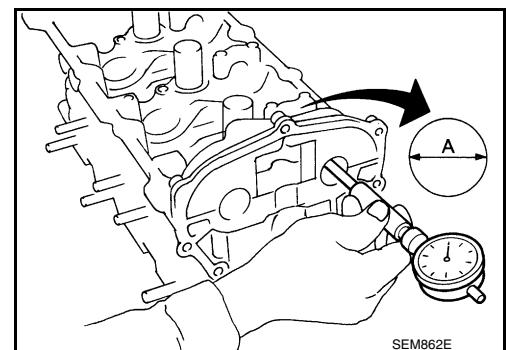

Calculation of Camshaft Journal Clearance

CAMSHAFT

< REMOVAL AND INSTALLATION >

(Journal clearance) = (inner diameter of camshaft bracket) – (outer diameter of camshaft journal). Refer to [EM-140, "Camshaft"](#).

- When out of the specified range, replace either or both camshaft and cylinder head.

NOTICE:

Inner diameter of camshaft bracket is manufactured together with cylinder head. Replace the whole cylinder head assembly.

Camshaft End Play

1. Install the camshaft in the cylinder head.
 2. Install dial gauge in thrust direction on front end of camshaft. Measure end play when camshaft is moved forward/backward (in direction to axis) as shown. Refer to [EM-140, "Camshaft"](#).
- If out of the specified range, replace with new camshaft and measure again.
 - If out of the specified range again, replace with new cylinder head.

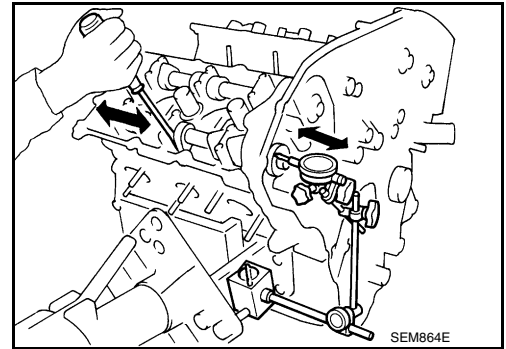

Camshaft Sprocket Runout

1. Put V-block on precise flat bed and support No. 2 and No. 4 journal of camshaft as shown.
2. Install camshaft sprocket on camshaft.
3. Measure camshaft sprocket runout. Refer to [EM-140, "Camshaft"](#).
4. If sprocket runout exceeds the limit, replace camshaft sprocket.

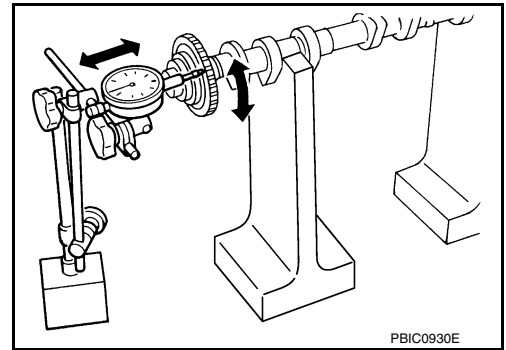

Valve Lifter

- Check if the surface of the valve lifter has any excessive wear or cracks, replace as necessary.

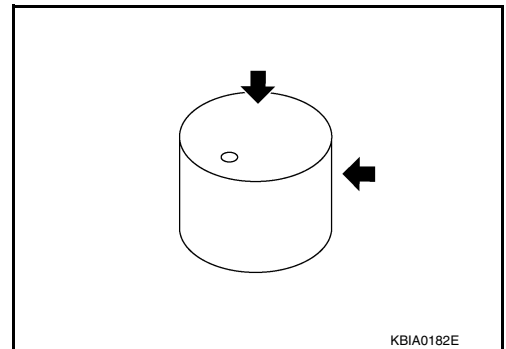

Valve Lifter Clearance

Outer Diameter of Valve Lifter

- Measure the outer diameter of the valve lifter with a suitable tool (A). Refer to [EM-140, "Camshaft"](#).
- If out of the specified range, replace the valve lifter.

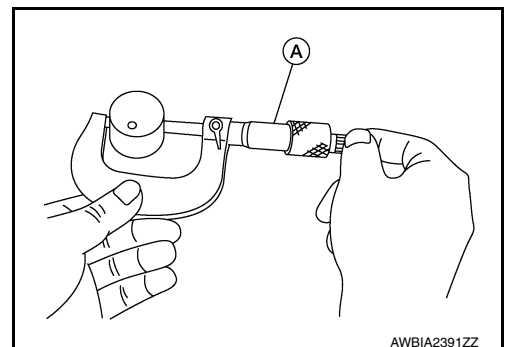

CAMSHAFT

< REMOVAL AND INSTALLATION >

Valve Lifter Bore Diameter

- Using inside micrometer, measure diameter of valve lifter bore of cylinder head. Refer to [EM-140, "Camshaft"](#).
- If out of the specified range, replace the cylinder head assembly.

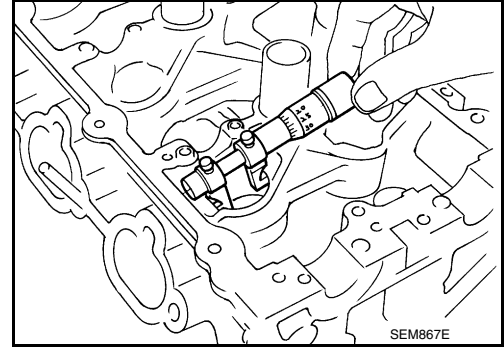

Calculation of Valve Lifter Clearance

- (Valve lifter clearance) = (hole diameter for valve lifter) – (outer diameter of valve lifter) Refer to [EM-140, "Camshaft"](#).
- If out of specified range, replace either or both valve lifter and cylinder head assembly.

Inspection after Installation

INFOID:000000011933783

INSPECTION OF CAMSHAFT SPROCKET (INT) OIL GROOVE

CAUTION:

- Perform this inspection only when DTC P0011 is detected in self-diagnostic results of CONSULT III and it is directed according to inspection procedure of EC section. Refer to [EC-198, "Diagnosis Procedure"](#).
- Check when engine is cold so as to prevent burns from any splashing engine oil.

1. Check engine oil level. Refer to [LU-8, "Inspection"](#).
2. Perform the following procedure so as to prevent the engine from being unintentionally started while checking.
 - a. Release fuel pressure. Refer to [FL-4, "Inspection"](#).
 - b. Disconnect ignition coil and injector harness connectors if practical.
3. Remove intake valve timing control solenoid valve.
4. Crank engine, and then make sure that engine oil comes out from intake valve timing control solenoid valve cover oil hole. End cranking after checking.

WARNING:

Be careful not to touch rotating parts (drive belts, idler pulley, and crankshaft pulley, etc.).

CAUTION:

- Engine oil may squirt from intake valve timing control solenoid valve installation hole during cranking. Use a shop cloth to prevent engine oil from splashing on worker, engine components and vehicle.
- Do not allow engine oil to get on rubber components such as drive belts or engine mount insulators. Immediately wipe off any splashed engine oil.

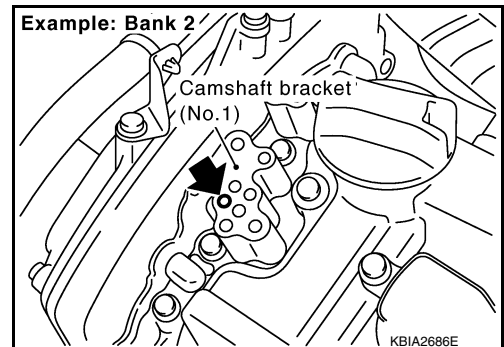

5. Clean oil groove between oil strainer and intake valve timing control solenoid valve if engine oil does not come out from intake valve timing control solenoid valve cover oil hole.
6. Remove components between intake valve timing control solenoid valve and camshaft sprocket (INT), and then check each oil groove for clogging.
 - Clean oil groove if necessary.
7. After inspection, installation of the remaining components is in the reverse order of removal.

OIL SEAL

< REMOVAL AND INSTALLATION >

OIL SEAL

Removal and Installation of Valve Oil Seal

INFOID:000000012232313

REMOVAL

1. Turn crankshaft until the cylinder requiring new oil seals is at TDC. This will prevent valve from dropping into cylinder.

CAUTION:

When rotating crankshaft, be careful to avoid scarring the front cover with the timing chain.

2. Remove camshaft relating to valve oil seal to be removed. Refer to [EM-79, "Removal and Installation"](#).
3. Remove valve lifters.
4. Remove valve collet, valve spring retainer and valve spring using suitable tool (A). Remove valve collet using suitable tool.

CAUTION:

- Be careful not to damage valve lifter bore.

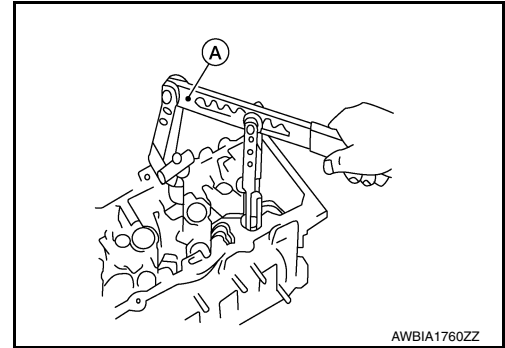

- Install a suitable tool (A) in the center of the valve spring retainer (1) to install it.

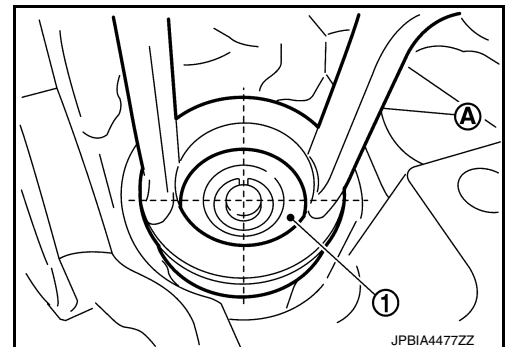

5. Remove valve oil seal using suitable tool (A).

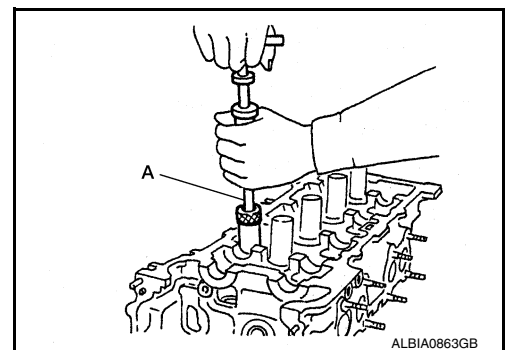

INSTALLATION

NOTE:

The valve spring is not equipped with the valve spring seat. Install the valve spring seat into the cylinder head before valve spring installation.

- Install the valve spring with the identification color facing upward.
- Install the smaller pitch to the cylinder head side.
- Intake and exhaust springs are the same.

1. Apply new engine oil to new valve oil seal joint surface and seal lip.

OIL SEAL

< REMOVAL AND INSTALLATION >

2. Press in valve oil seal to height (H) using suitable tool (A).
NOTE:
Dimension (H): height measured before valve spring seat installation.

Intake and exhaust (H) : 14.3 - 14.9 mm (0.563 - 0.587 in)

3. Installation of the remaining components is in the reverse order of removal.

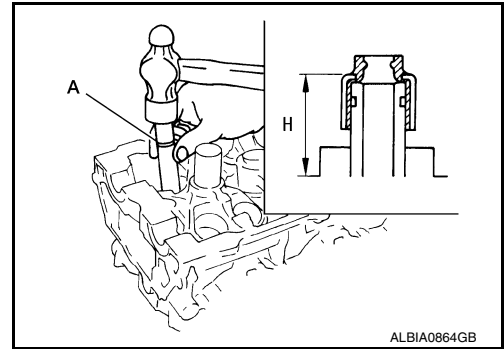

INFOID:000000012232315

Removal and Installation of Front Oil Seal

REMOVAL

1. Remove drive belt. Refer to [EM-16. "Removal and Installation"](#).
2. Lock the drive plate using Tool.

Tool number : — (J-50288)

CAUTION:

Do not damage the ring gear teeth or the signal plate teeth behind the ring gear when setting the Tool.

3. Remove the crankshaft pulley as follows:
 - a. Loosen crankshaft pulley and locate bolt seating surface at 10 mm (0.39 in) from its original position.
 - b. Position a pulley puller at recess hole of crankshaft pulley to remove crankshaft pulley.

CAUTION:

Do not use a puller claw on the outer diameter of the crankshaft pulley.

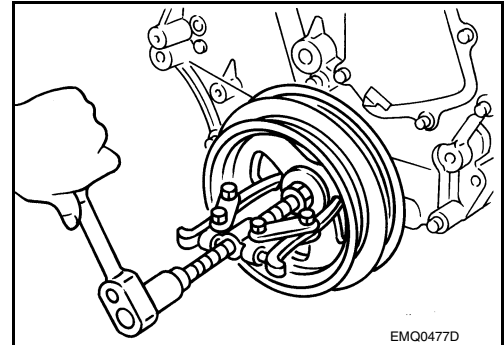

4. Remove front oil seal from front cover using a suitable tool.

CAUTION:

Be careful not to damage front cover or crankshaft.

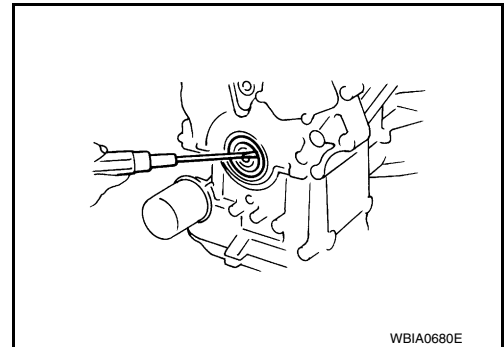

INSTALLATION

OIL SEAL

< REMOVAL AND INSTALLATION >

1. Apply new engine oil to new oil seal and install using suitable tool (A).
 - Install new oil seal in the direction as shown.

CAUTION:

Press fit straight and avoid causing burrs or tilting the oil seal.

- Press-fit oil seal until it becomes flush with the timing chain case end face, using suitable tool.
- Make sure the garter spring in the oil seal is in position and seal lip is not inverted.

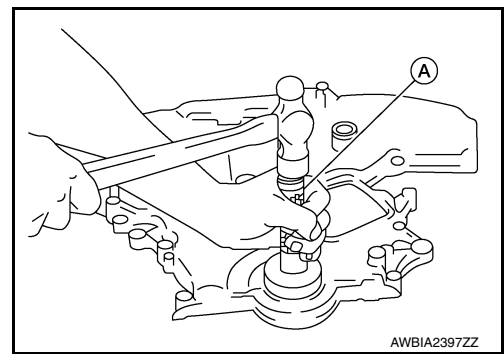

2. Install crankshaft pulley and tighten the bolt in two steps.
 - Lubricate thread and seat surface of the bolt with new engine oil.
 - For the second step angle tighten using Tool.

CAUTION:

- Do not damage the front oil seal when inserting crankshaft pulley.
- Use only brass or plastic hammer if tapping on the crankshaft pulley.
- Do not hammer on pulley grooves.

Step 1 : 44.1 N·m (4.5 kg-m, 33 ft-lb)

Step 2 : 90°(+0°/-6°) degrees clockwise

Tool number : KV10112100 (BT-8653-A)

3. Remove the Tool to unlock the drive plate.

Tool number : — (J-50288)

CAUTION:

Do not damage the ring gear teeth, or the signal plate teeth behind the ring gear, when removing the Tool.

4. Installation of the remaining components is in the reverse order of removal.

Removal and Installation of Rear Oil Seal

INFOID:000000012232316

REMOVAL

1. Remove the upper oil pan. Refer to [EM-40. "Removal and Installation \(Upper Oil Pan\)"](#).
2. Remove drive plate. Refer to [EM-115. "Exploded View"](#).
3. Remove rear oil seal retainer using Tool (A).

Tool Number : KV10111100 (J-37228)

CAUTION:

- Be careful not to damage mating surface.
- If rear oil retainer is removed, replace it with a new one

NOTE:

Rear oil seal and retainer form a single part and are replaced as an assembly.

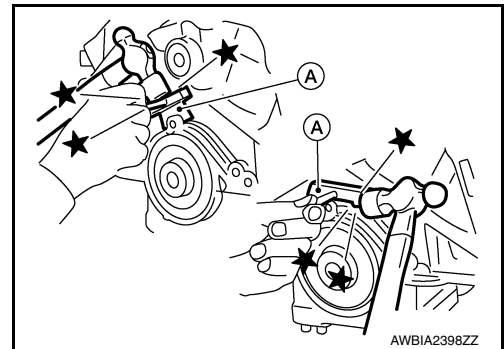

INSTALLATION

1. Remove old liquid gasket material from mating surface of cylinder block and oil pan using a suitable scraper.

OIL SEAL

< REMOVAL AND INSTALLATION >

2. Install the rear oil seal retainer using Tool (A).

Tool number : — (J-47128)

- Loosen the wing nut (B) on the end of the Tool (A).
- Insert the arbor (D) into the crankshaft pilot hole until the outer lip (C) of the Tool (A) covers the edge of the crankshaft sealing surface.
- Tighten the wing nut (B) to secure the Tool (A) to the crankshaft.

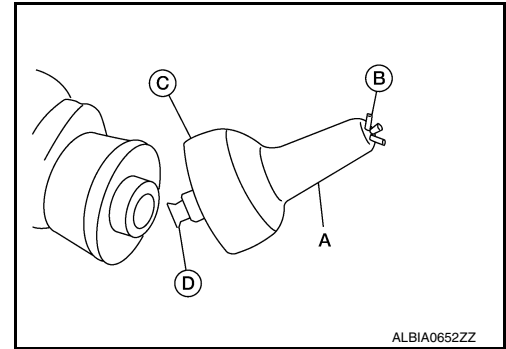

- Apply sealant to rear oil seal retainer as shown. Use **Genuine Silicone RTV Sealant** or equivalent. Refer to [GI-22, "Recommended Chemical Products and Sealants"](#).

CAUTION:

- Installation should be done within 5 minutes after applying liquid gasket.
- Do not fill the engine with oil for at least 30 minutes after the components are installed to allow the liquid gasket to cure.

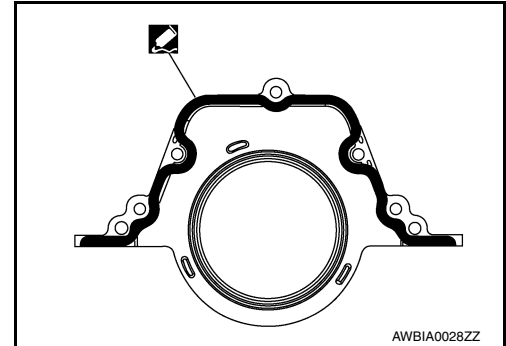

- Lubricate the sealing surface of the new rear main seal with new engine oil.
- Slide the new rear main seal (1) over the Tool (A) and onto the crankshaft.
- Loosen the wing nut and push the threaded rod into the handle to remove the Tool (A).
- Tighten the rear oil seal retainer bolts to specification.

Rear oil seal retainer bolts : 8.8 N·m (0.9 kg-m, 78 in-lb)

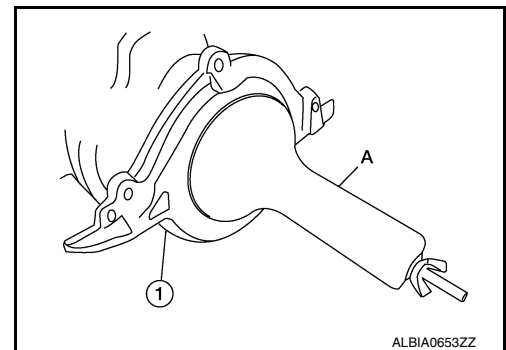

3. Installation of the remaining components is in the reverse order of removal.

CAUTION:

- When replacing an engine or transmission you must make sure the dowels are installed correctly during re-assembly.
- Improper alignment caused by missing dowels may cause vibration, oil leaks or breakage of drivetrain components.

CYLINDER HEAD

< REMOVAL AND INSTALLATION >

CYLINDER HEAD

Exploded View

INFOID:000000012232318

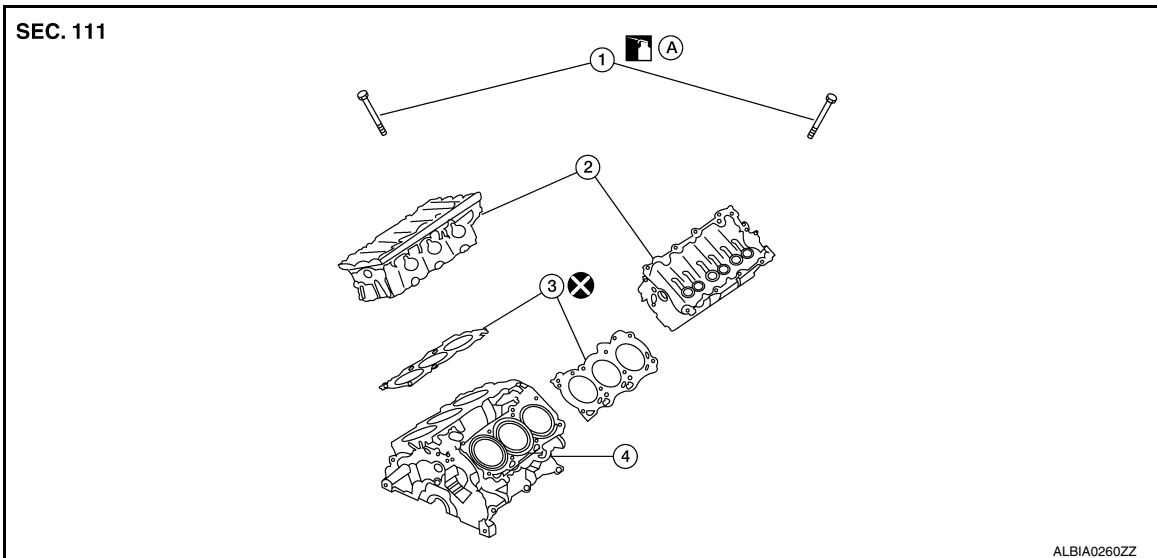

- 1. Cylinder head bolt
- 2. Cylinder head
- 3. Cylinder head gasket
- 4. Engine block
- A. Refer to INSTALLATION

Removal and Installation

INFOID:000000012232320

REMOVAL

1. Remove the engine from the vehicle. Refer to [EM-107, "Removal and Installation"](#).
2. Remove the rear timing chain case. Refer to [EM-74, "Removal and Installation"](#).
3. Remove the intake manifold. Refer to [EM-30, "Removal and Installation"](#).
4. Remove the exhaust manifold and three way catalyst (bank 1/bank 2). Refer to [EM-36, "Exploded View"](#).
5. Remove the intake and exhaust camshafts. Refer to [EM-79, "Removal and Installation"](#).
6. Remove the water outlet housing. Refer to [CO-25, "Exploded View"](#).
7. Remove the bolts from bank 1 cylinder head (A) and bank 2 cylinder head (B).
 - The bolts should be loosened gradually in three stages.
 - Loosen the bolts in the reverse tightening sequence as shown.

← :Engine front

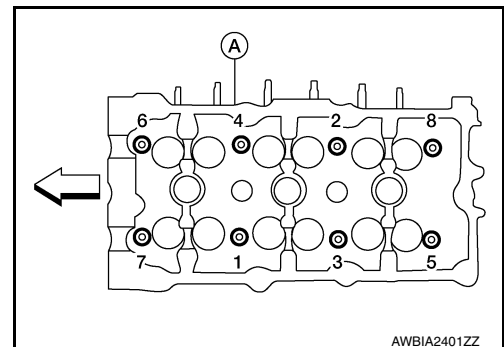

CYLINDER HEAD

< REMOVAL AND INSTALLATION >

8. Remove cylinder head (A) and cylinder head gasket.

CAUTION:

Do not reuse cylinder head gaskets.

← :Engine front

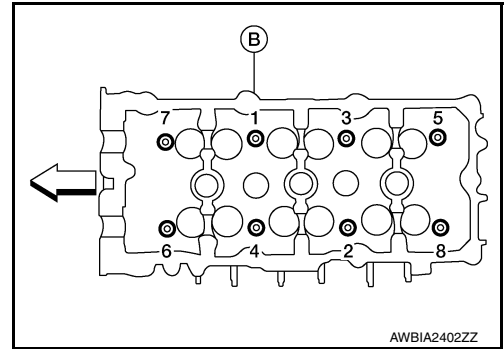

AWBIA2402ZZ

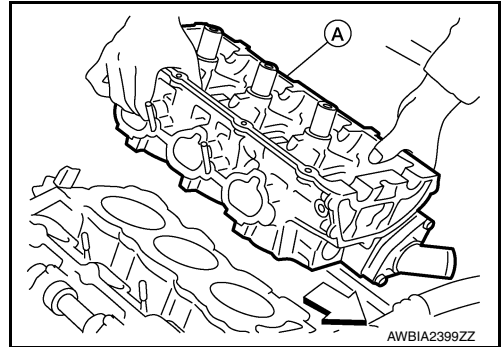

AWBIA2399ZZ

INSTALLATION

1. Turn the crankshaft until No. 1 piston is set at TDC on the compression stroke.
- The crankshaft key (A) should line up with the bank 1 cylinder head center line (B) as shown.

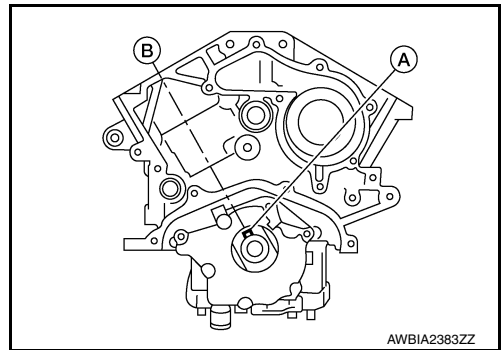

AWBIA2383ZZ

2. Install new cylinder head gaskets.
- CAUTION:**
Do not reuse cylinder head gaskets.
3. Inspect the cylinder head bolts (B) before installing the cylinder heads.

CAUTION:

Cylinder head bolts (B) are tightened by degree rotation tightening method. Observing measuring points (A), whenever the size difference between d1 and d2 exceeds the limit, replace the bolts with new ones.

Limit (d1 - d2) : 0.11 mm (0.0043 in)

- Lubricate threads and seat surfaces of the bolts with new engine oil.

← :Engine front

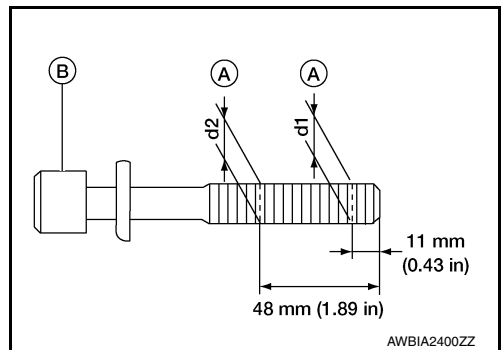

AWBIA2400ZZ

4. Install the bank 1 cylinder head (A) and bank 2 cylinder head (B) on the cylinder block. Tighten the cylinder head bolts in the five steps in the numerical order as shown using Tool.

CAUTION:

Do not rotate crankshaft and camshaft separately or valves will strike piston heads.

CYLINDER HEAD

< REMOVAL AND INSTALLATION >

Tool Number : KV10112100 (BT-8653-A)

• **Tightening procedure:**

Cylinder head bolts

- Step 1 : 98.1 N·m (10 kg-m, 72 ft-lb) in order**
- Step 2 : Loosen bolts in the reverse order of tightening.**
- Step 3 : 39.2 N·m (4.0 kg-m, 29 ft-lb) in order**
- Step 4 : 103° degrees rotation in order**
- Step 5 : 103° degrees rotation in order**

← :Engine front

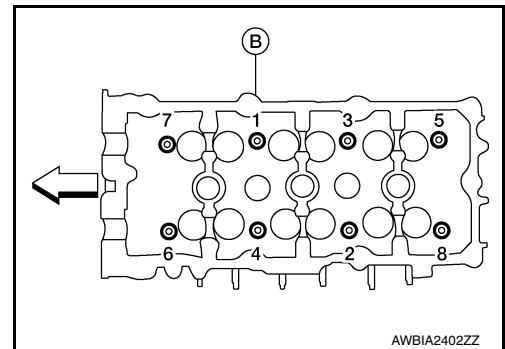
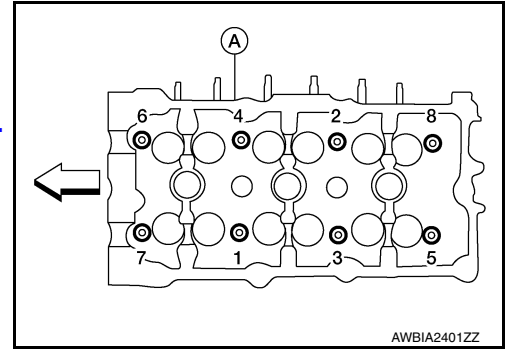

5. Installation of the remaining components is in the reverse order of removal.

A
EM
C
D
E
F
G
H
I
J
K
L
M
N
O
P

CYLINDER HEAD

< REMOVAL AND INSTALLATION >

Disassembly and Assembly

INFOID:000000012232321

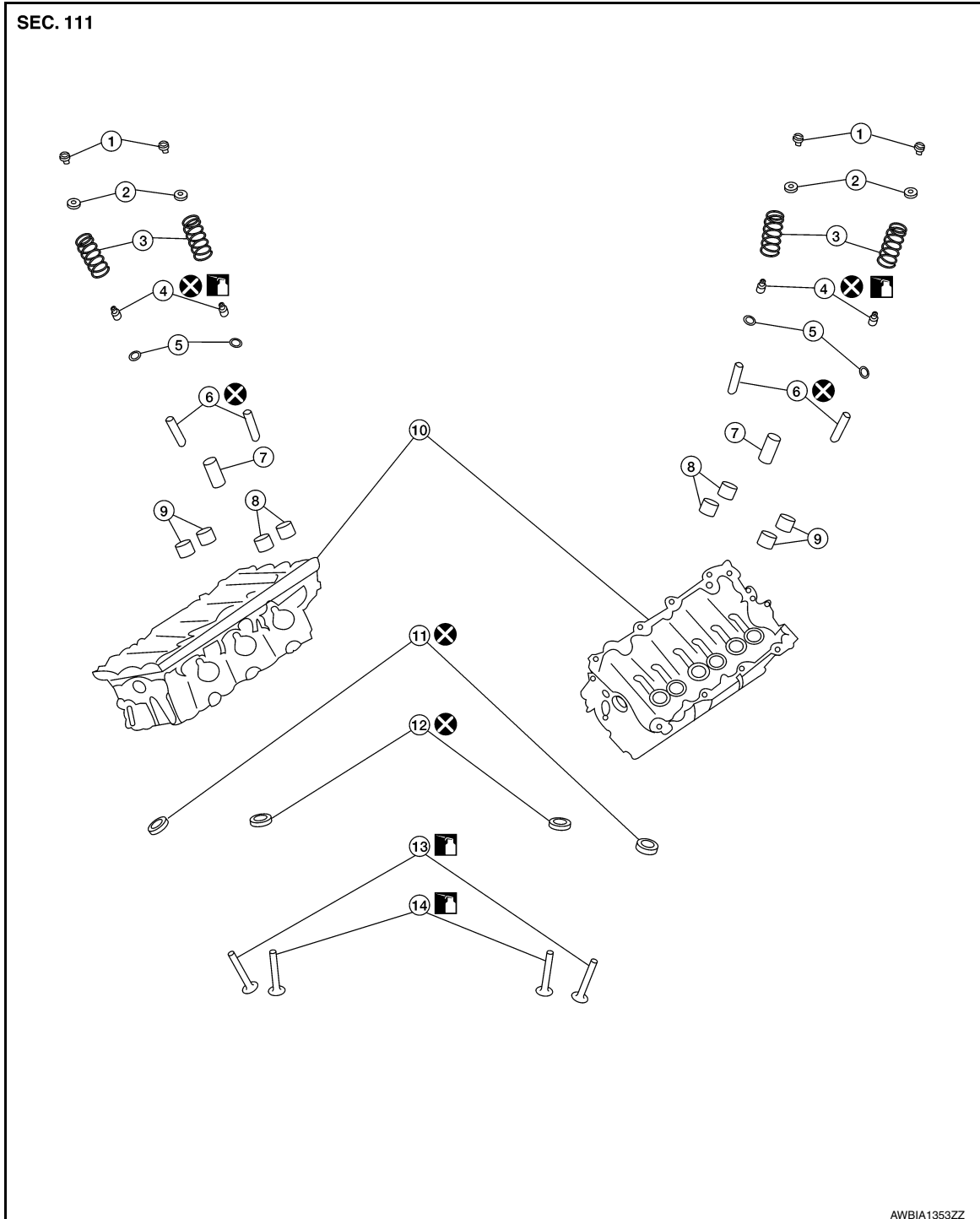

- | | | |
|--------------------|--------------------------|----------------------|
| 1. Valve collet | 2. Valve spring retainer | 3. Valve spring |
| 4. Valve oil seal | 5. Valve spring seat | 6. Valve guide |
| 7. Spark plug tube | 8. Lifter (INT) | 9. Lifter (EXH) |
| 10. Cylinder head | 11. Valve seat (EXH) | 12. Valve seat (INT) |
| 13. Valve (EXH) | 14. Valve (INT) | |

CAUTION:

- When installing camshafts, chain tensioners, oil seals, or other sliding parts, lubricate contacting surfaces with new engine oil.
- Apply new engine oil to threads and seat surface when installing cylinder head, camshaft sprocket, crankshaft pulley, and camshaft bracket.

CYLINDER HEAD

< REMOVAL AND INSTALLATION >

- Attach tags to valve lifters so as not to mix them up.

DISASSEMBLY

1. Remove spark plug.
2. Remove valve lifter.
 - Identify installation positions and store them without mixing them up.
3. Remove valve collet.

- Compress valve spring and remove valve collet with magnet hand using suitable tool (A)

CAUTION:

When working, take care not to damage valve lifter bore.

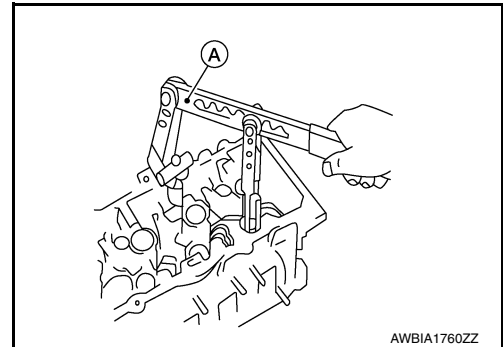

- Install a suitable tool (A) in the center of the valve spring retainer (1) to remove it.

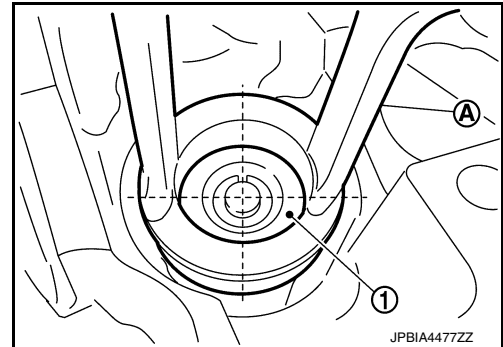

4. Remove valve spring retainer, valve spring and valve spring seat.
5. Push valve stem to combustion chamber side and remove valve.
 - Identify installation positions, and store them without mixing them up.
6. Remove valve oil seals using suitable tool (A).

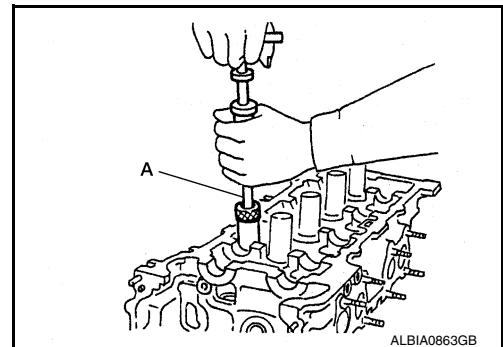

7. If valve seat must be replaced, refer to [EM-97, "Inspection After Disassembly"](#).
8. If valve guide must be replaced, refer to [EM-97, "Inspection After Disassembly"](#).
9. Remove spark plug tube, as necessary.
 - Using pair of pliers, pull spark plug tube out of cylinder head.

CAUTION:

 - Take care not to damage cylinder head.
 - Once removed, spark plug tube will be deformed and cannot be reused. Do not remove it unless absolutely necessary.

ASSEMBLY

1. When valve guide is removed, install it. Refer to [EM-97, "Inspection After Disassembly"](#).
2. When valve seat is removed, install it. Refer to [EM-97, "Inspection After Disassembly"](#).

A
EM
C
D
E
F
G
H
I
J
K
L
M
N
O
P

CYLINDER HEAD

< REMOVAL AND INSTALLATION >

3. Install valve oil seals using suitable tool (A).

Height (H) (Without valve spring seat installed)

Intake and exhaust : 14.3 - 14.9 mm (0.563 - 0.587 in)

4. Install valve spring seat.
5. Install valves.
• Install it in the original position.

NOTE:

Larger diameter valves are for intake side.

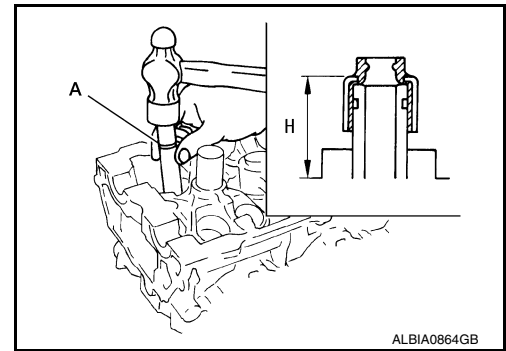

6. Install valve spring.
• Install the valve spring so that the identification color facing upward (A).
• Install smaller pitch to cylinder head side (B).
• Confirm the identification color of the valve spring.
• Intake and exhaust springs are the same.

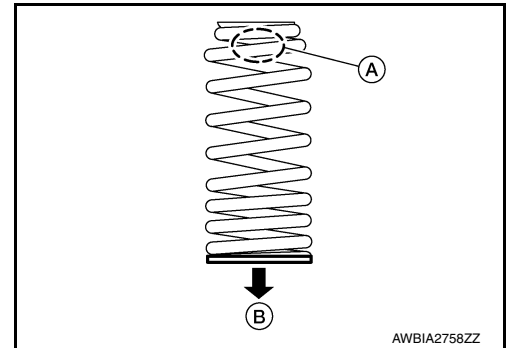

7. Install valve spring retainer.
• Install a suitable tool (A) in the center of the valve spring retainer (1) to install.

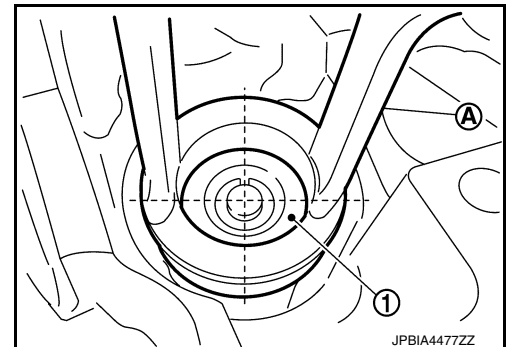

8. Install valve collet.
• Compress valve spring using suitable tool (A), attachment and adapter. Install valve collet with magnet hand.

CAUTION:

When working, take care not to damage valve lifter bore.

- Tap valve stem edge lightly with plastic hammer after installation to check its installed condition.

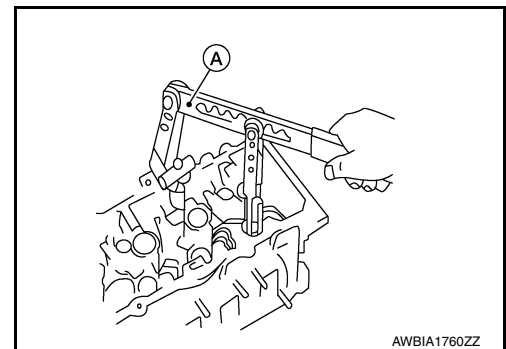

9. Install valve lifter.
• Install it in the original position.
10. Install spark plug tube.
• Press-fit spark plug tube as follows:
a. Remove old liquid gasket adhering to cylinder head mounting hole.

CYLINDER HEAD

< REMOVAL AND INSTALLATION >

- b. Apply sealant to area (A) within approximately 12 mm (0.47 in) from edge of spark plug tube press-fit side.
Use Genuine High Strength Locking Sealant or equivalent. Refer to [GI-22, "Recommended Chemical Products and Sealants"](#).
 - c. Press-fit spark plug tube so that its height (H) is as specified.
Refer to [EM-91, "Removal and Installation"](#).
CAUTION:
 - When press-fitting, take care not to deform spark plug tube.
 - After press-fitting, wipe off liquid gasket protruding onto cylinder-head upper face.
11. Install spark plug. Refer to [EM-14, "Exploded View"](#).

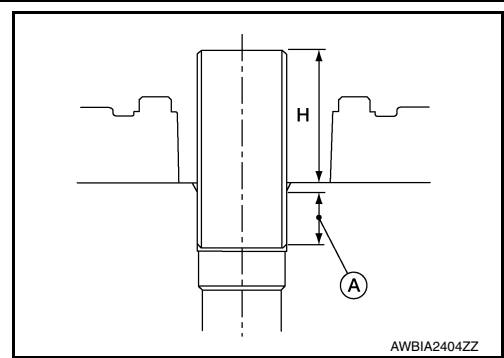

Inspection After Disassembly

INFOID:000000012232322

CYLINDER HEAD DISTORTION

Clean the surface of the cylinder head. Use a reliable straightedge and feeler gauge to check the flatness of cylinder head surface.

Check along six positions as shown. Refer to [EM-94, "Disassembly and Assembly"](#)

If it exceeds the limit, replace the cylinder head.

The limit for cylinder head resurfacing is determined by the cylinder block resurfacing. Refer to [EM-142, "Cylinder Head"](#)

After resurfacing cylinder head, check that camshaft rotates freely by hand. If resistance is felt, cylinder head must be replaced.

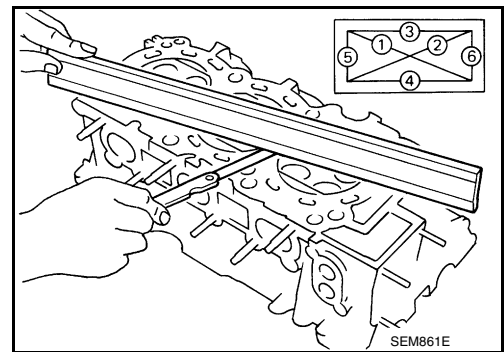

VALVE GUIDE CLEARANCE

1. Measure valve deflection (D) using a suitable tool (C) as shown (Valve and valve guide mostly wear in this direction). Measuring direction (E) should be 90° (B) of camshaft direction (A). Refer to [EM-142, "Cylinder Head"](#).

Maximum deflection : 0.25 mm (0.010 in)

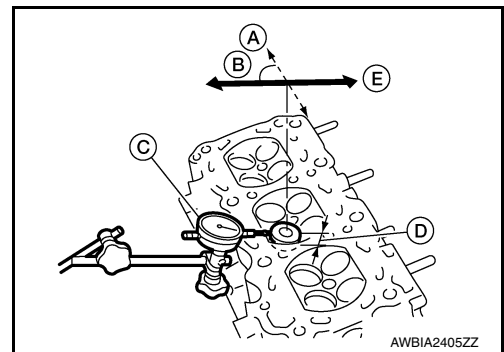

2. If it exceeds the limit, check valve to valve guide clearance with a suitable tool (A).
 - a. Measure valve stem diameter and valve guide inner diameter. Refer to [EM-142, "Cylinder Head"](#).
 - b. Check that clearance is within specification.
 (Valve guide clearance) = (Valve guide inner diameter) - (Valve stem diameter). Refer to [EM-142, "Cylinder Head"](#).
 - c. If it exceeds the limit, replace valve or valve guide.

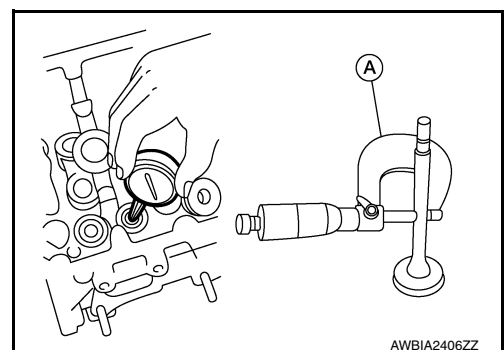

CYLINDER HEAD

< REMOVAL AND INSTALLATION >

VALVE GUIDE REPLACEMENT

When valve guide is removed, replace with oversized [0.2 mm (0.008 in)] valve guide.

1. To remove valve guide, heat cylinder head to 110 - 130°C (230 - 266°F) by soaking in heated oil (A).

WARNING:

Cylinder head contains heat. When working, wear protective equipment to avoid getting burned.

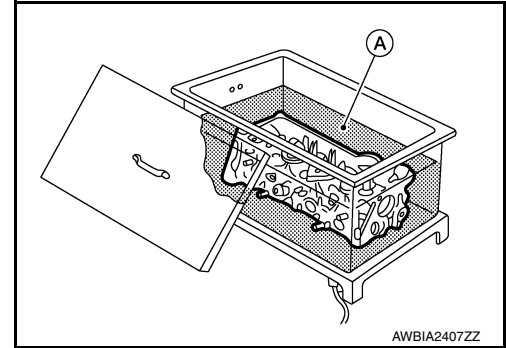

2. Drive out the valve guide with a press [under a 20 kN (2.2 US ton) pressure] or hammer and suitable tool.

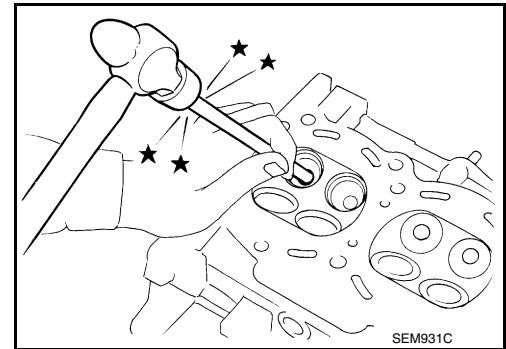

3. Ream cylinder head valve guide hole using suitable tool (A). Refer to [EM-142, "Cylinder Head"](#).

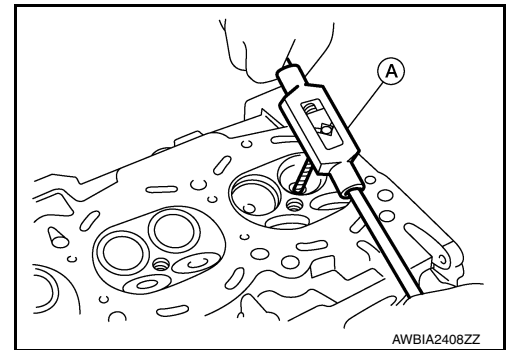

4. Heat cylinder head to 110 - 130°C (230 - 266°F) by soaking in heated oil and press new valve guide from camshaft side into the cylinder head to the dimensions (L) as shown. Refer to [EM-142, "Cylinder Head"](#).

WARNING:

Cylinder head contains heat. When working, wear protective equipment to avoid getting burned.

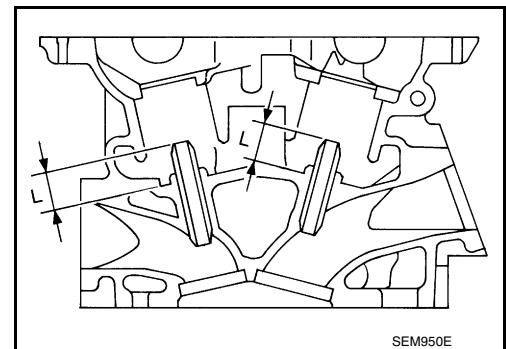

CYLINDER HEAD

< REMOVAL AND INSTALLATION >

- Using a suitable tool (A), apply a reamer finish to the valve guide.

Intake and exhaust finished size : 6.000 - 6.018 mm (0.2362 - 0.2369 in)

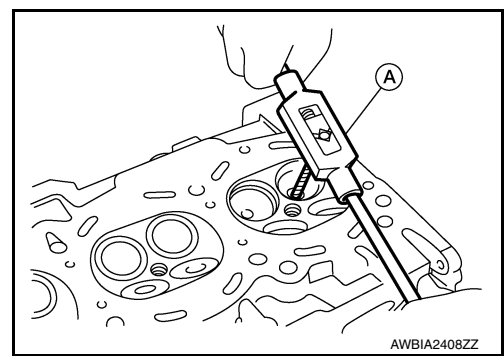

VALVE SEAT CONTACT

- After confirming that the dimensions of valve guides and valves are within specifications, perform this procedure.
- Apply Prussian blue onto contacting surface of valve seat to check the condition of the valve contact on the surface.
- Check if the contact area band is continuous all around the circumference.
- If not, grind to adjust valve fitting and check again. If the contacting surface still has NG conditions even after the recheck, replace valve seat.

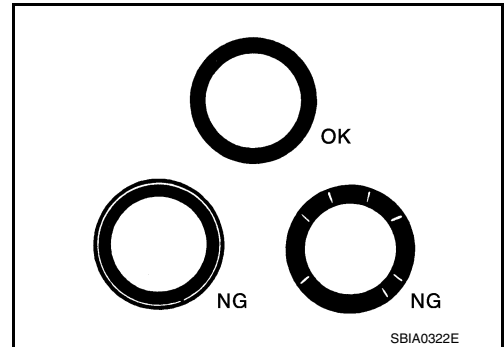

VALVE SEAT REPLACEMENT

- Bore out old seat (A) until it collapses. Boring should not continue beyond the bottom face of the seat recess in cylinder head. Set the machine depth stop to ensure this.
- Ream cylinder head recess for service valve seat. Refer to [EM-142. "Cylinder Head"](#)

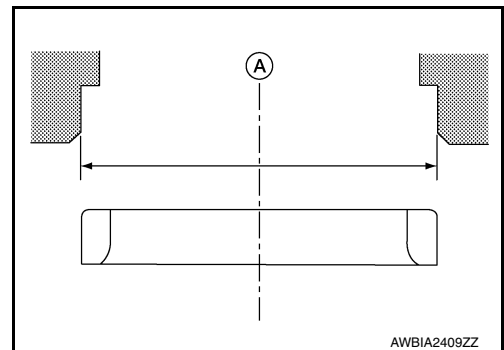

Be sure to ream in circles concentric to the valve guide center. This will enable valve seat to fit correctly.

- Heat cylinder head to 110 - 130°C (230 - 266°F) by soaking in heated oil (A).

WARNING:

Cylinder head contains heat. when working, wear protective equipment to avoid getting burned.

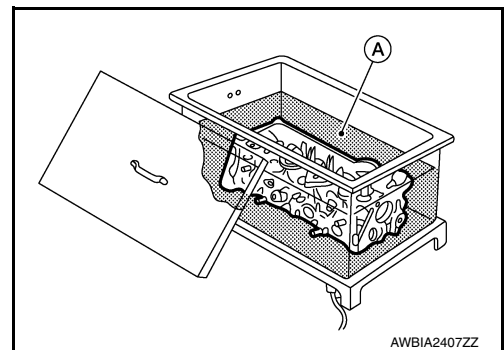

- Press fit valve seat until it seats on the bottom.
- Cut or grind valve seat using suitable tool to the specified dimensions. Refer to [EM-142. "Cylinder Head"](#).
- After cutting, lap valve seat with abrasive compound.

CYLINDER HEAD

< REMOVAL AND INSTALLATION >

7. Check valve seating condition. Refer to [EM-142, "Cylinder Head"](#).

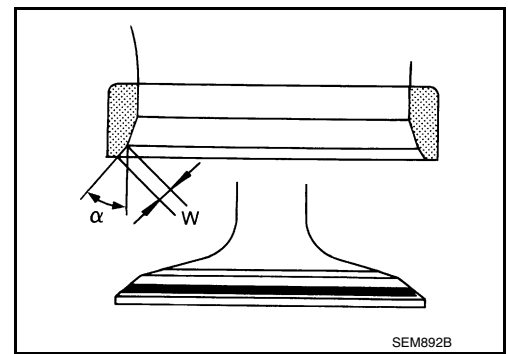

8. Use a depth gauge to measure the distance between the mounting surface of the cylinder head spring seat and the valve stem end on the exhaust (A) and intake (B) sides. If the distance is shorter than specified, repeat step 5 to adjust it. If it is longer, replace the valve seat with a new one. Refer to [EM-142, "Cylinder Head"](#).

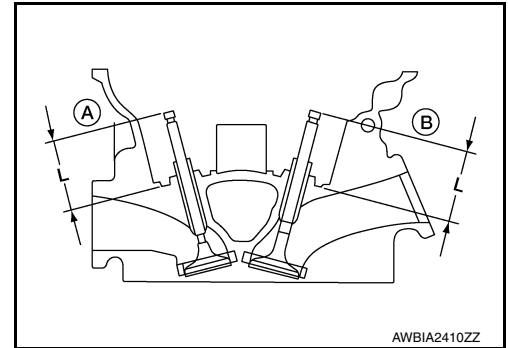

VALVE SPRING SQUARENESS

Set try square (A) along the side of valve spring and rotate the spring. Measure the maximum clearance (d) between the top of valve spring and try square.

- (B) : Contact
(C) : V-block

Limit : Refer to [EM-142, "Cylinder Head"](#).

- If it exceeds the limit, replace valve spring.

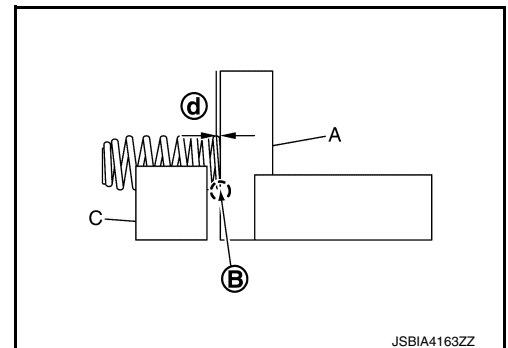

VALVE SPRING DIMENSIONS AND VALVE SPRING PRESSURE LOAD

Check valve spring pressure at specified spring height. If it is not within specifications, replace the spring. Refer to [EM-142, "Cylinder Head"](#).

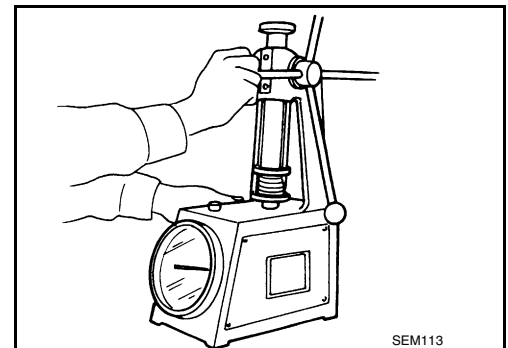

ENGINE MOUNT

< REMOVAL AND INSTALLATION >

ENGINE MOUNT

ENGINE MOUNT (FRONT)

ENGINE MOUNT (FRONT) : Removal and Installation

INFOID:0000000011933790

A

EM

WARNING:

- Do not start work until the engine and exhaust system are cooled completely.

CAUTION:

Do not damage or spill oil on the engine mount (Front) insulator.

NOTE:

When removing components such as hoses, tubes/lines, etc., cap or plug openings to prevent fluid from spilling.

C

D

REMOVAL

1. Remove the air cleaner assembly, front air duct, and air duct hose and resonator tube assembly. Refer to [EM-26, "Removal and Installation"](#).
2. Remove the battery. Refer to [PG-103, "Removal and Installation \(Battery Tray\)"](#).
3. Remove the battery tray assembly. Refer to [PG-103, "Removal and Installation \(Battery Tray\)"](#).
4. Remove the transmission control module (TCM). Refer to [TM-191, "Removal and Installation"](#).
5. Remove the engine control module (ECM). Refer to [EC-586, "Removal and Installation"](#).
6. Disconnect the harness from the ECM and TCM bracket, then remove the ECM and TCM bracket.
7. Remove the coolant from the radiator. Refer to [CO-12, "Changing Engine Coolant"](#).
8. Remove the upper radiator hose.
9. Remove the inlet heater pipe (lower)
10. Remove the fan shroud and motor assembly. Refer to [CO-16, "Removal and Installation"](#).
11. Remove the exhaust manifold heat shield (bank 2). Refer to [EM-36, "Removal and Installation \(bank 2\)"](#).
12. Support the engine (1) and transaxle (2) using a suitable jack (A) as shown.

E

F

G

H

I

CAUTION:

- Position a suitable jack under the engine and transaxle assembly as shown.
- Do not damage the front exhaust tube or transaxle oil pan with the jack.

J

K

L

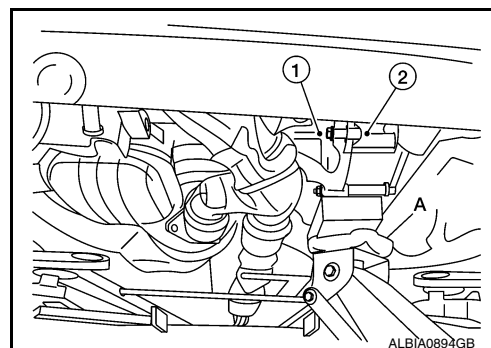

ALBIA0894GB

13. Disconnect the air/fuel ratio sensor electrical connector.
14. Disconnect the engine mount insulator (front) vacuum hose.
15. Remove the engine mount insulator (front) nut (A).

M

N

O

P

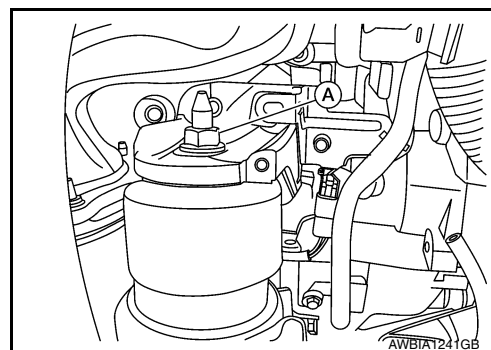

AWBIA1241GB

ENGINE MOUNT

< REMOVAL AND INSTALLATION >

16. Loosen the engine mount bracket (front) bolts in the reverse order shown.

⇐ : Engine front

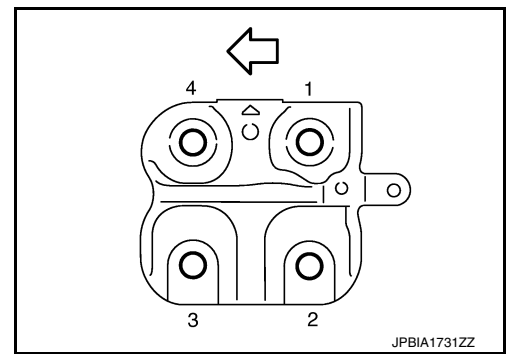

17. Remove the engine mount bracket (front).

18. Remove the engine mount insulator (front) bolts in the reverse order as shown.

⇐ : Vehicle front

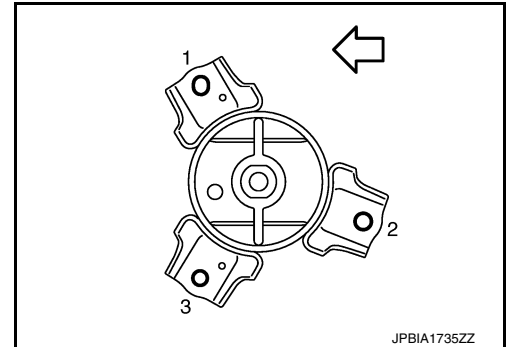

19. Remove the engine mount insulator (front).

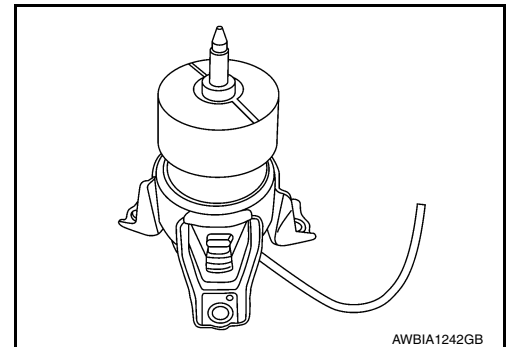

INSTALLATION

1. Install the engine mount insulator (front).

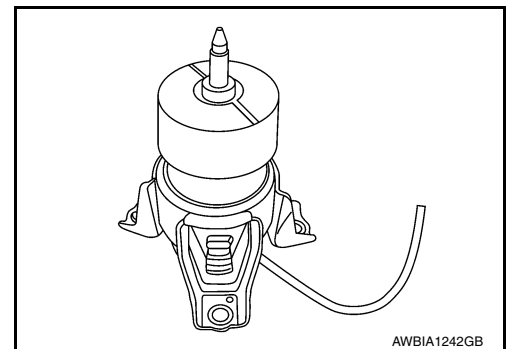

ENGINE MOUNT

< REMOVAL AND INSTALLATION >

2. Install the engine mount insulator (front) bolts and tighten to specification in the order shown.

⇐ : Front

Engine mount insulator (front) bolts : 43 N·m (4.4 kg-m, 32 ft-lb)

CAUTION:

Check engine mount insulator (front) is seated properly before tightening.

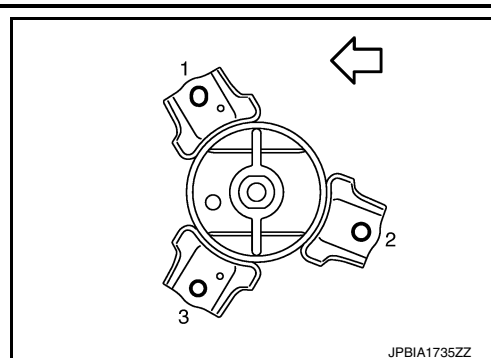

3. Install the engine mount bracket (front) to the engine block.
4. Tighten the engine mount bracket (front) bolts to specification in the order shown.

⇐ : Engine front

Engine mount bracket (front) bolts : 40 N·m (4.1 kg-m, 30 ft-lb)

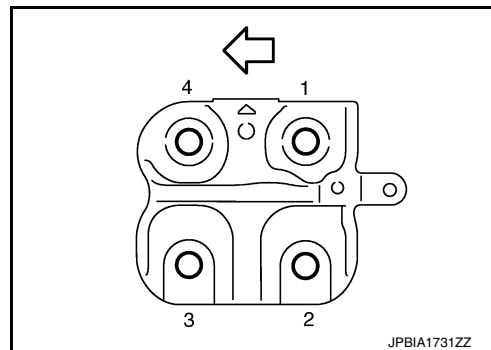

5. Install the engine mount insulator (front) nut (A) and tighten to specification.

Engine mount insulator (front) nut : 103 N·m (11 kg-m, 76 ft-lb)

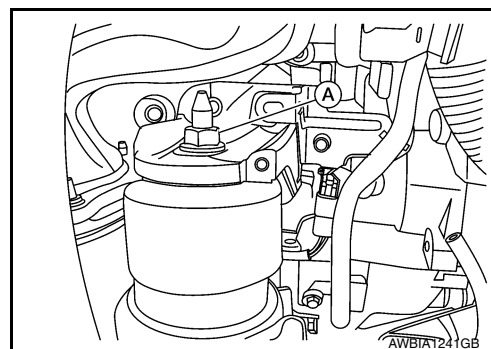

6. Installation of the remaining components is in the reverse order of removal.

ENGINE MOUNT (REAR)

ENGINE MOUNT (REAR) : Removal and Installation

INFOID:000000012271787

WARNING:

- Do not start work until the engine and exhaust system are cooled completely.

CAUTION:

Do not damage or spill oil on the engine mount insulator (rear).

NOTE:

When removing components such as hoses, tubes/lines, etc., cap or plug openings to prevent fluid from spilling.

REMOVAL

1. Disconnect the battery negative terminal. Refer to [PG-101, "Exploded View"](#).
2. Remove cowl top extension. Refer to [EXT-25, "Removal and Installation"](#).
3. Remove the air cleaner and air duct. Refer to [EM-26, "Removal and Installation"](#).
4. Remove the strut brace.
5. Remove engine room cover. Refer to [EM-25, "Removal and Installation"](#).
6. Remove the air cleaner assembly. Refer to [EM-26, "Removal and Installation"](#).
7. Remove the engine under cover. Refer to [EXT-26, "Removal and Installation"](#).

ENGINE MOUNT

< REMOVAL AND INSTALLATION >

8. Remove the tire and wheel. Refer to [WT-67, "Removal and Installation"](#).
9. Use a suitable jack (A) to securely support the bottom of the engine (1) and the transaxle assembly (2).

CAUTION:

Put a piece of wood or an equivalent as the supporting surface and secure in a stable condition.

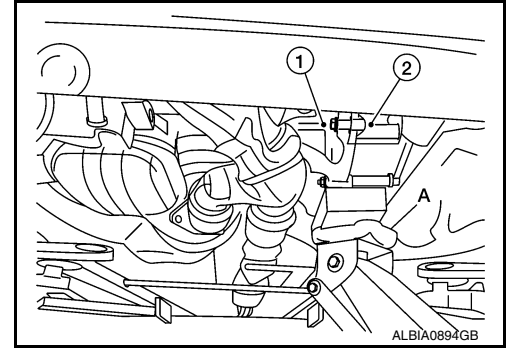

10. Disconnect the brake booster vacuum hose.
11. Disconnect the RH sway bar link from the front strut.
12. Remove the RH front drive shaft assembly. Refer to [FAX-20, "Removal and Installation \(RH\)"](#).
13. Remove front exhaust tube. Refer to [EX-5, "Exploded View"](#).
14. Disconnect the air/fuel ratio sensor electrical connector.
15. Remove the LH TWC heat shield.
16. Disconnect the VIAS control solenoid electrical connector.
17. Disconnect the following:
 - Vacuum hose at the power valve.
 - Vacuum hose at the intake collector.
 - EVAP vacuum hose.
18. Disconnect the EVAP canister purge control solenoid electrical connector, then remove the EVAP canister purge control solenoid.
19. Disconnect the throttle actuator electrical connector, then set the throttle body aside. Discard the gasket.
20. Disconnect the PCV breather hose.
21. Remove the intake manifold collector. Refer to [EM-30, "Removal and Installation"](#).
22. Remove the engine mount insulator nut (A).

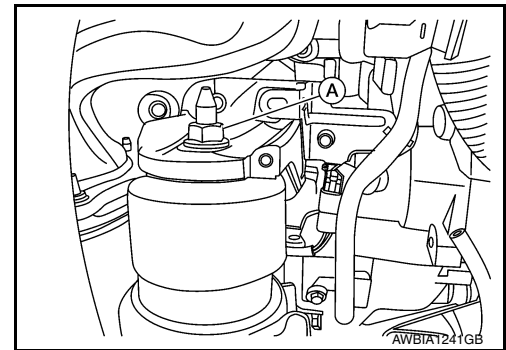

23. Loosen the engine mount bracket bolts in the reverse order shown.

⇐ : Engine front

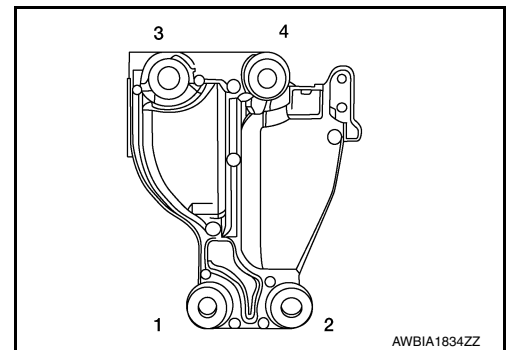

24. Remove the engine mount bracket.

ENGINE MOUNT

< REMOVAL AND INSTALLATION >

25. Remove the engine mount insulator bolts in the reverse order as shown.

← : Vehicle front

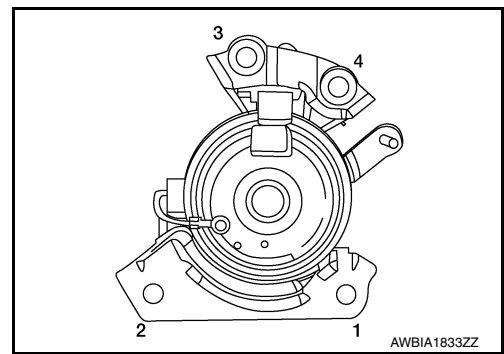

26. Remove the engine mount insulator.

NOTE:

Raise or lower engine and transaxle assembly as required with shop crane.

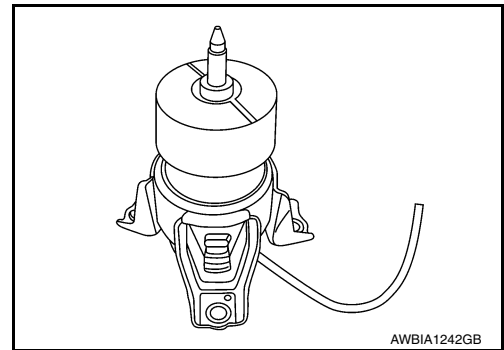

INSTALLATION

Installation is in the reverse order of removal.

NOTE:

Do not allow oil to get on mounting insulators. Be careful not to damage mounting insulators.

1. Install the engine mount insulator (rear).

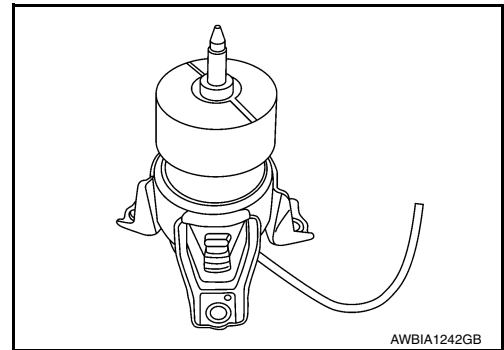

2. Remove front drive shaft assemblies from vehicle. Refer to [FAX-18. "Removal and Installation \(LH\)"](#) and [FAX-20. "Removal and Installation \(RH\)"](#).
3. Install the engine mount insulator (rear) to the front suspension member as follows:

← : Front

- a. Temporarily tighten the bolts in the sequence as shown.
- b. Tighten the engine mount insulator (rear) bolts to specification in the sequence as shown. Refer to [EM-103. "ENGINE MOUNT \(REAR\) : Removal and Installation"](#).

CAUTION:

Check engine mount insulator is seated properly before tightening.

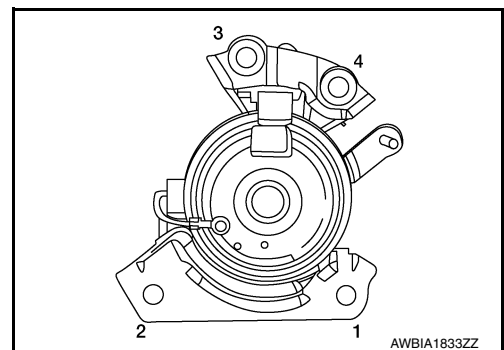

A
EM
C
D
E
F
G
H
I
J
K
L
M
N
O
P

ENGINE MOUNT

< REMOVAL AND INSTALLATION >

4. Tighten engine mount insulator (rear) ground strap bolt to specification. Refer to [EM-103, "ENGINE MOUNT \(REAR\) : Removal and Installation"](#).
5. Install the engine mount bracket (rear) to the engine block.
6. Tighten the engine mount bracket (rear) to the engine as follows:

⇐ : Engine front

- a. Temporarily tighten the bolts in the sequence as shown.
- b. Tighten the engine mount bracket (rear) bolts to specification in the sequence as shown. Refer to [EM-103, "ENGINE MOUNT \(REAR\) : Removal and Installation"](#).

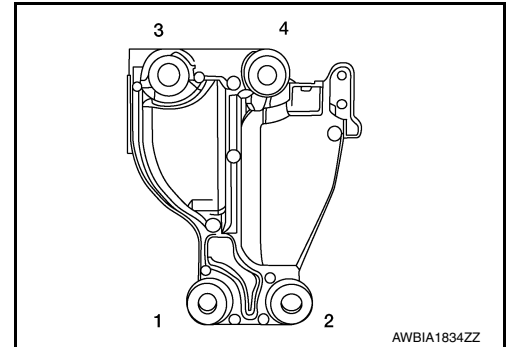

7. Install the engine mount insulator nut (rear) (A) and tighten to specification. Refer to [EM-103, "ENGINE MOUNT \(REAR\) : Removal and Installation"](#).

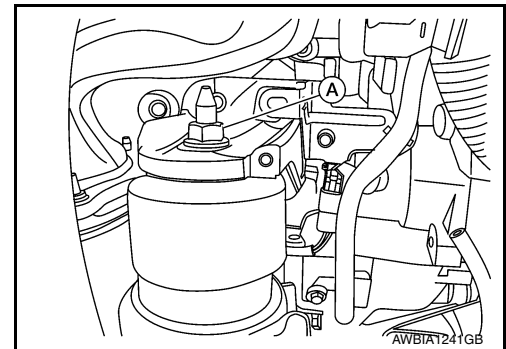

8. Install a new throttle body gasket.

ENGINE ASSEMBLY

< UNIT REMOVAL AND INSTALLATION >

UNIT REMOVAL AND INSTALLATION

ENGINE ASSEMBLY

Removal and Installation

INFOID:000000011933791

A

EM

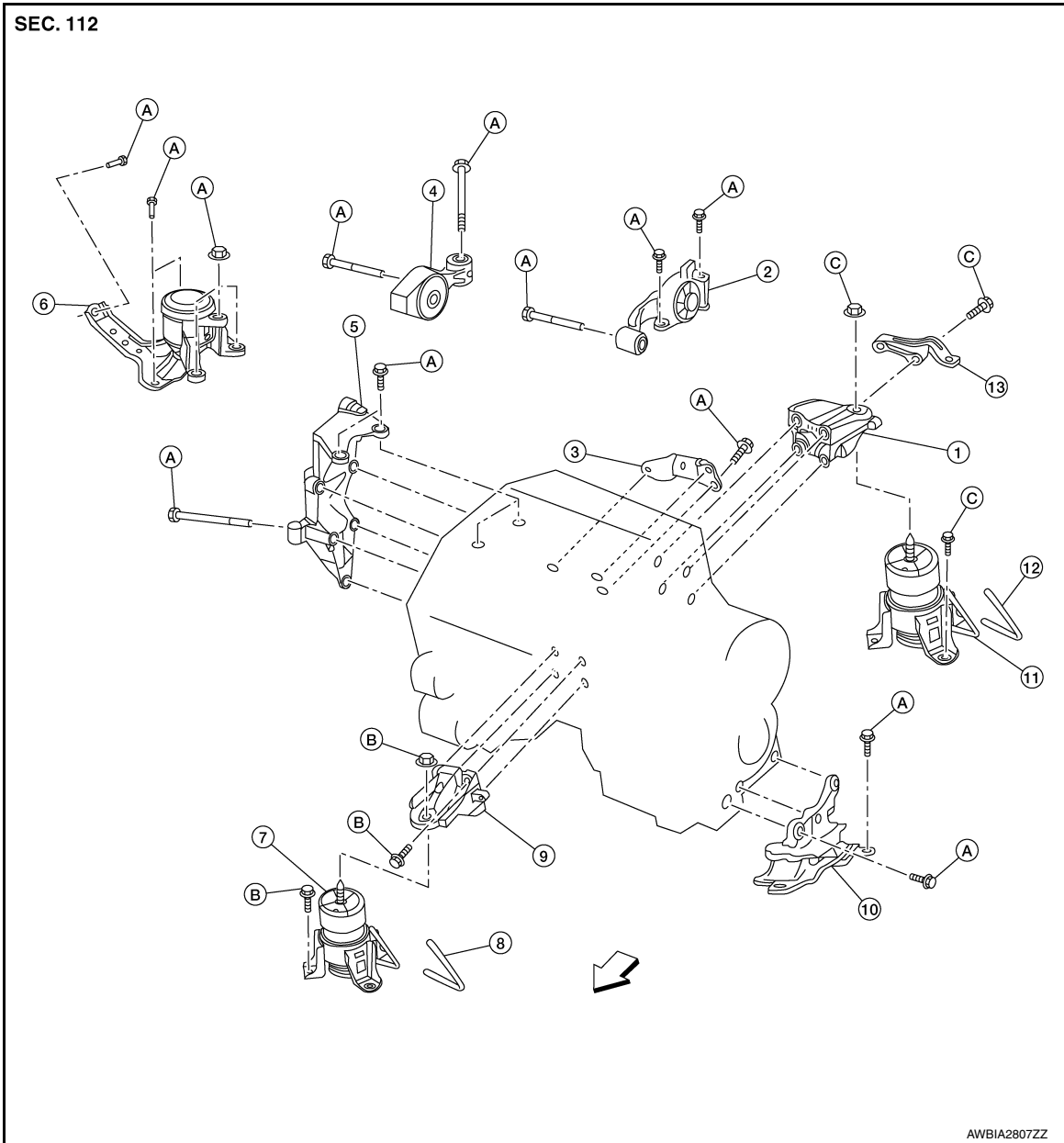

- | | | |
|--------------------------------------|--------------------------------------|------------------------------------|
| 1. Engine mounting bracket (rear) | 2. Rear torque rod | 3. Rear torque rod bracket |
| 4. Upper torque rod | 5. Engine mounting bracket (RH) | 6. Engine mounting insulator (RH) |
| 7. Engine mounting insulator (front) | 8. Harness connector | 9. Engine mounting bracket (front) |
| 10. Engine mounting insulator (LH) | 11. Engine mounting insulator (rear) | 12. Harness connector |

C

D

E

F

G

H

I

J

K

L

M

N

O

P

ENGINE ASSEMBLY

< UNIT REMOVAL AND INSTALLATION >

13. Engine mounting bracket support (rear)
- A. Refer to INSTALLATION
- B. Refer to [EM-101, "ENGINE MOUNT \(FRONT\) : Removal and Installation"](#) (Engine Mount - Front)
- C. Refer to [EM-103, "ENGINE MOUNT \(REAR\) : Removal and Installation"](#) (Engine Mount - Rear) ⇐ Front

WARNING:

- Place chocks at front and back of rear wheels.
- For engines not equipped with engine slingers, attach proper slingers and bolts as described in the NISSAN Parts Catalog.

CAUTION:

- Do not start working until exhaust system and coolant are cool.
- If items or work required are not covered by the engine main body section, follow the applicable procedures.
- Use the correct supporting points for lifting and jacking. Refer to [GI-29, "Garage Jack and Safety Stand and 2-Pole Lift"](#).
- In removing the drive shafts, be careful not to damage any transaxle grease seals.
- Before separating the engine and transaxle, remove the crankshaft position sensor (POS). Refer to [EM-66, "Exploded View"](#).
- Do not damage the edge of the crankshaft position sensor (POS) or the ring gear teeth.

NOTE:

When removing components such as hoses, tubes/lines, etc., cap or plug openings to prevent fluid from spilling.

REMOVAL

1. Release fuel pressure. Refer to [EC-168, "Work Procedure"](#).
2. Drain coolant. Refer to [CO-12, "Changing Engine Coolant"](#).
3. Drain power steering fluid. Refer to [ST-29, "Draining and Refilling"](#).
4. Remove the front under cover. Refer to [EXT-26, "Removal and Installation"](#).
5. Remove the fender protector (LH/RH). Refer to [EXT-28, "Removal and Installation"](#).
6. Remove the engine room cover. Refer to [EM-25, "Removal and Installation"](#).
7. Remove front air duct, air duct hose and resonator assembly and air cleaner case assembly. Refer to [EM-26, "Removal and Installation"](#).
8. Remove the cowl top cover, cowl top extension, and cowl top brace (RH). Refer to [EXT-25, "Removal and Installation"](#).
9. Disconnect the harness connector from the battery current sensor. Refer to [PG-106, "Exploded View"](#).
10. Remove battery tray. Refer to [PG-103, "Removal and Installation \(Battery Tray\)"](#).
11. Remove IPDM E/R. Refer to [PCS-36, "Removal and Installation"](#).
12. Remove the relay-fuse box cover and release the harness connectors.
13. Remove the ground wire from the side of the transaxle assembly.
14. Remove the ground wire from the front timing cover.
15. Disconnect the coolant reservoir hose, then remove the coolant reservoir.
16. Remove upper radiator hose. Refer to [CO-14, "Exploded View"](#).
17. Disconnect CVT oil warmer hoses from CVT oil warmer.
18. Disconnect fuel hose quick connection at vehicle piping side. Refer to [FL-4, "Quick Connector"](#).
19. Disconnect EVAP vacuum hose.
20. Disconnect heater hoses (engine side). Refer to [CO-25, "Exploded View"](#).
21. Disconnect control cable at transaxle side. Refer to [TM-187, "Exploded View"](#).
22. Remove lower radiator hose. Refer to [CO-14, "Exploded View"](#).
23. Disconnect brake booster vacuum hose from the intake manifold collector.
24. Remove power steering oil pump. Refer to [ST-43, "Removal and Installation"](#).

ENGINE ASSEMBLY

< UNIT REMOVAL AND INSTALLATION >

25. Remove the upper torque rod bolts in the reverse order as shown.

⇐ : Front

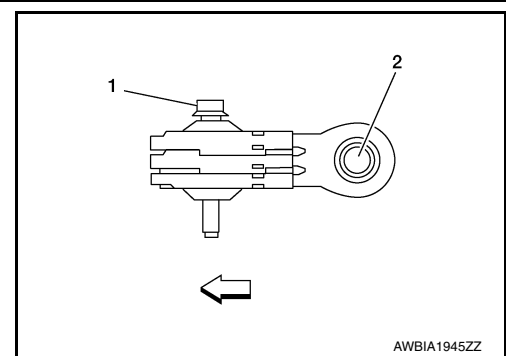

26. Remove the upper torque rod.
27. Remove engine mounting insulator (RH) bolts in reverse order as shown.

⇐ : Front

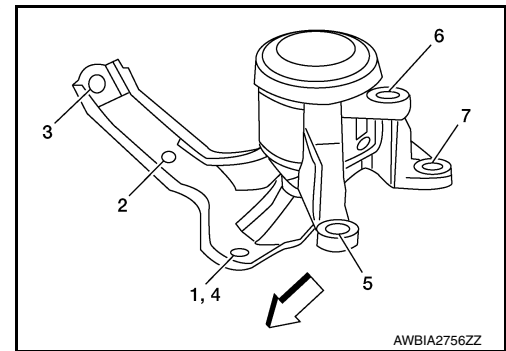

28. Remove the engine mounting insulator (RH).
29. Discharge and recover the R134a refrigerant. Refer to [HA-25, "Recycle Refrigerant"](#).
30. Disconnect the A/C high side and low side hoses from the A/C compressor. Refer to [HA-37, "LOW-PRESSURE PIPE : Removal and Installation"](#) and [HA-38, "HIGH-PRESSURE PIPE : Removal and Installation"](#).
31. Disconnect the stabilizer connecting rods at the strut (LH/RH). Refer to [FSU-15, "Exploded View"](#).
32. Remove the front drive shafts. Refer to [FAX-18, "Removal and Installation \(LH\)"](#) (LH) and [FAX-20, "Removal and Installation \(RH\)"](#) (RH).
33. Remove cotter pin from outer socket stud.
34. Loosen outer socket nut and separate outer socket from steering knuckle (RH/LH) using suitable tool.
CAUTION:
Leave outer socket nut half threaded on outer socket to prevent damage to threads and to prevent suitable tool from coming off suddenly.
35. Remove outer socket nut and separate outer socket from steering knuckle (RH/LH). Refer to [ST-39, "Exploded View"](#).
36. Remove front strut bolts at steering knuckle (RH/LH). Refer to [FSU-10, "Exploded View"](#).
37. Remove steering knuckle lower pinch bolt and nut and separate transverse link from steering knuckle (RH/LH).
38. Remove steering knuckle (RH/LH).
39. Remove rear torque rod bolts in reverse order as shown.

⇐ : Front

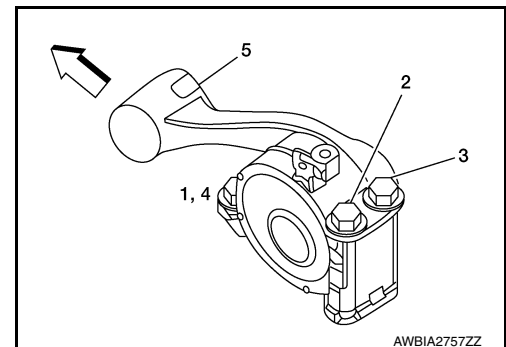

40. Remove rear torque rod.

ENGINE ASSEMBLY

< UNIT REMOVAL AND INSTALLATION >

41. Remove the front exhaust tube. Refer to [EX-5. "Removal and Installation"](#).
42. Remove the steering gear heat shield.
43. Remove the power steering line from the sub frame.
44. Remove the steering gear bolts, then support the steering gear.
45. Install engine slingers into front of cylinder head (LH) and rear of cylinder head (RH) then tighten to specified torque.
 - (A): cylinder head (RH)

Bolts (B) : 28 N·m (2.9 kg-m, 21 ft-lb)

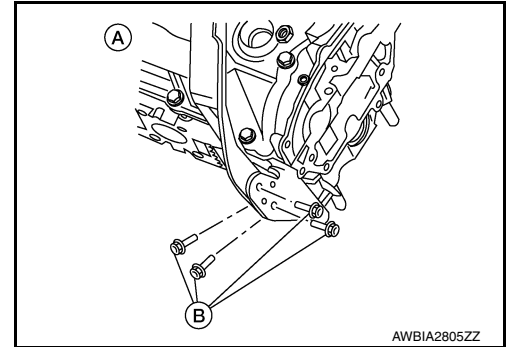

- (B): cylinder head (LH)

Bolts (A) : 28 N·m (2.9 kg-m, 21 ft-lb)

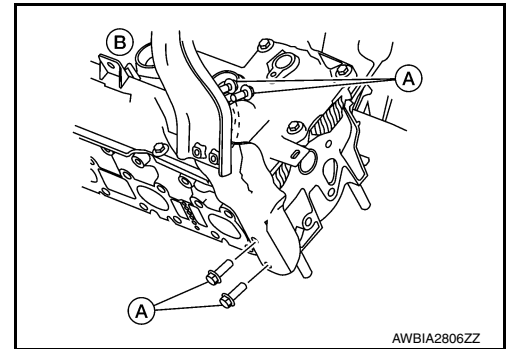

46. Remove rear cover plate.
47. Remove the torque converter nuts.
48. Disconnect vacuum hoses from engine mounting insulator (front) and engine mounting insulator (rear).
49. Position a suitable support table under suspension member and engine assembly.
50. For additional safety, secure the engine in position with suitable tool.
51. Remove suspension member bolts. Refer to [FSU-18. "Removal and Installation"](#).
52. Carefully lower the engine, transaxle assembly and suspension member using suitable tool, avoiding interference with the vehicle body.

CAUTION:

- **Before and during this procedure, always check if any harnesses are left connected.**
- **Avoid any damage to, or any oil/grease smearing or spills onto the engine mount insulators.**

53. Remove the starter motor. Refer to [STR-19. "Removal and Installation"](#).
54. Remove the crankshaft position sensor (POS). Refer to [EM-66. "Removal and Installation"](#).
55. Disconnect CVT input speed sensor, CVT primary speed sensor, CVT output speed sensor, and CVT unit harness connector. Refer to [TM-201. "Exploded View"](#), [TM-202. "Exploded View"](#) and [TM-203. "Exploded View"](#).
56. Separate the engine from the transaxle assembly.
57. Remove engine mount insulator (front). Refer to [EM-101. "ENGINE MOUNT \(FRONT\) : Removal and Installation"](#).

CAUTION:

To remove engine mount components, partially support weight of engine assembly with shop crane.

58. Remove engine mount insulator (rear). Refer to [EM-103. "ENGINE MOUNT \(REAR\) : Removal and Installation"](#).

CAUTION:

To remove engine mount components, partially support weight of engine assembly with shop crane.

ENGINE ASSEMBLY

< UNIT REMOVAL AND INSTALLATION >

59. Lift the engine from the suspension member.
60. Remove engine mounting bracket (RH) bolts in reverse order as shown (if necessary).

← : Front

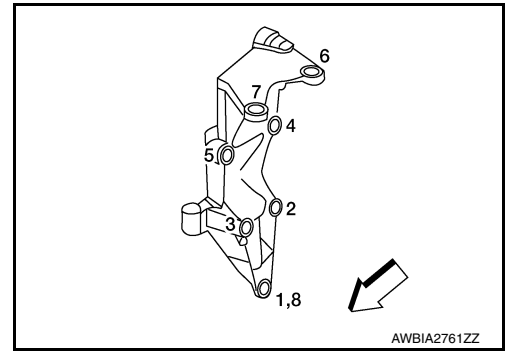

61. Remove engine mounting bracket (RH) (if necessary).
62. Remove rear torque rod bracket bolts in reverse order as shown (if necessary).

← : Front

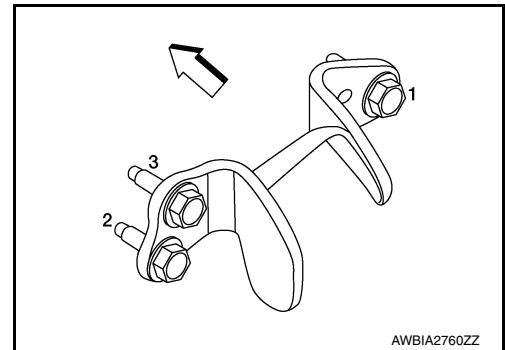

63. Remove rear torque rod bracket (if necessary).
64. Remove engine mounting bracket (front) bolts in reverse order as shown (if necessary).

← : Front

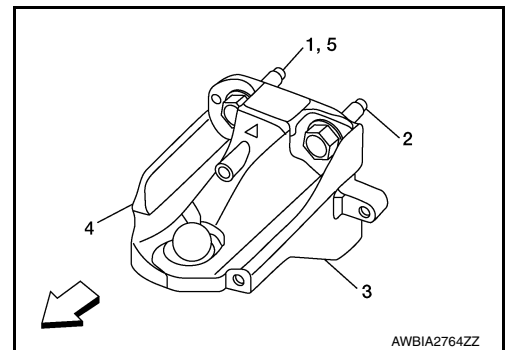

65. Remove engine mounting bracket (front) (if necessary).
66. Remove engine mounting bracket (rear) bolts in reverse order as shown (if necessary).

← : Front

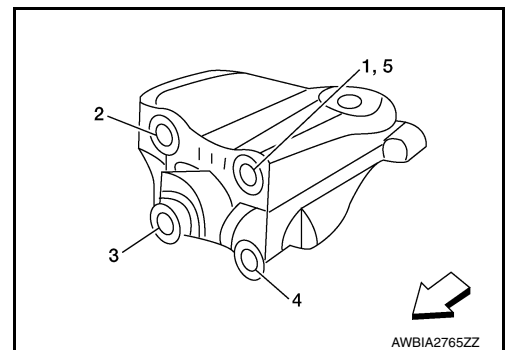

67. Remove engine mounting bracket (rear) (if necessary).

A
EM
C
D
E
F
G
H
I
J
K
L
M
N
O
P

ENGINE ASSEMBLY

< UNIT REMOVAL AND INSTALLATION >

68. Remove engine mounting insulator (LH) bolts in reverse order as shown (if necessary).

⇐ : Front

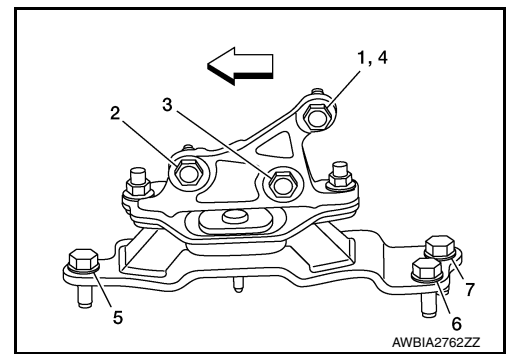

69. Remove engine mounting insulator (LH) (if necessary).

INSTALLATION

Installation is in the reverse order of removal.

CAUTION:

- Do not allow oil to get on mounting insulators.
- Be careful not to damage mounting insulators.

NOTE:

- Tighten transmission bolts to specification. Refer to [TM-212. "Exploded View"](#).

1. Install engine mounting insulator (LH) as follows:

- a. Temporarily tighten bolt located at position 1.
- b. Tighten the remaining bolts in sequence as shown to the specified torque.

⇐ : Front

Bolts : 80 N·m (8.2 kg-m, 59 ft-lb)

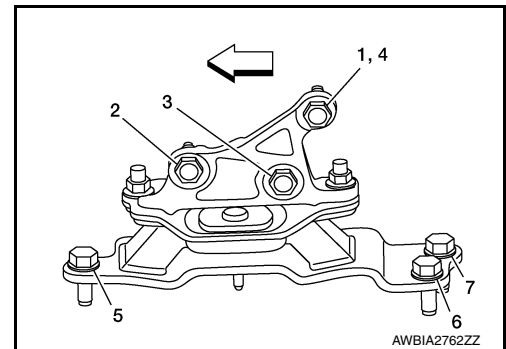

2. Install engine mounting bracket (rear) as follows:

- a. Temporarily tighten bolt located at position 1.
- b. Tighten the remaining bolts in sequence as shown to the specified torque.

⇐ : Front

Bolts : 40 N·m (4.1 kg-m, 30 ft-lb)

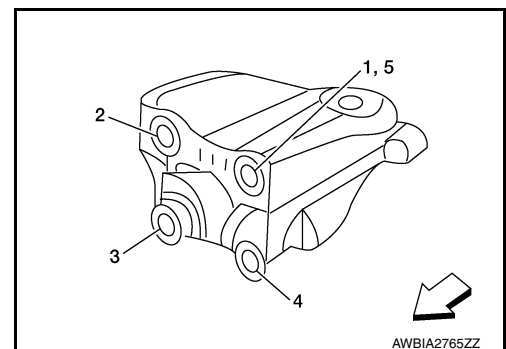

3. Install engine mounting bracket (front) as follows:

- a. Temporarily tighten bolt located at position 1.
- b. Tighten the remaining bolts in sequence as shown to the specified torque.

⇐ : Front

Bolts : 40 N·m (4.1 kg-m, 30 ft-lb)

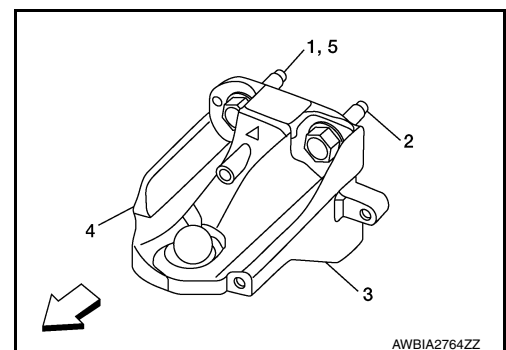

ENGINE ASSEMBLY

< UNIT REMOVAL AND INSTALLATION >

4. Install rear torque rod bracket as follows:

a. Tighten the bolts in sequence as shown to the specified torque.

⇐ : Front

Bolts : 40 N·m (4.1 kg-m, 30 ft-lb)

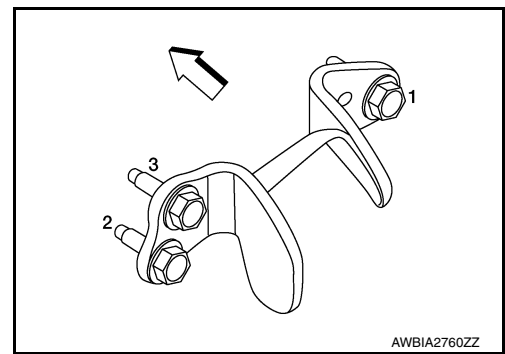

5. Install engine mounting bracket (RH) as follows:

a. Temporarily tighten bolt located at position 1.

b. Tighten the remaining bolts in sequence as shown to the specified torque.

⇐ : Front

Bolts : 90 N·m (9.2 kg-m, 66 ft-lb)

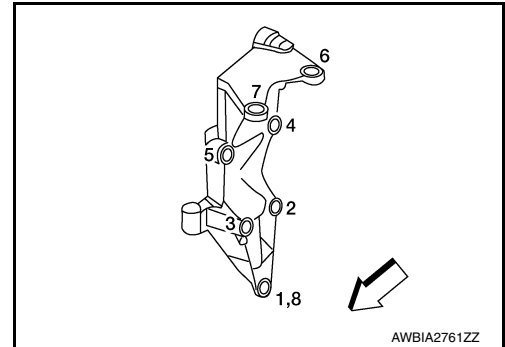

6. Install rear torque rod as follows:

a. Temporarily tighten bolt located at position 1.

b. Tighten the remaining bolts in sequence as shown to the specified torque.

⇐ : Front

Bolts · Positions 2, 3 : 35 N·m (3.6 kg-m, 26 ft-lb)

Bolt : Position 4 : 50 N·m (5.1 kg-m, 37 ft-lb)

Bolt : Position 5 : 103 N·m (11 kg-m, 76 ft-lb)

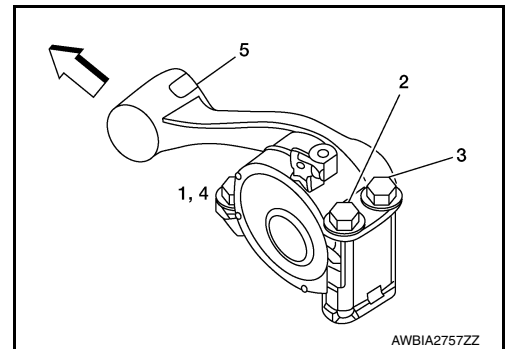

7. Install engine mounting insulator (RH) as follows:

a. Temporarily tighten bolt located at position 1.

b. Tighten the remaining bolts in sequence as shown to the specified torque.

⇐ : Front

Nut and Bolts : 50 N·m (5.1 kg-m, 37 ft-lb)

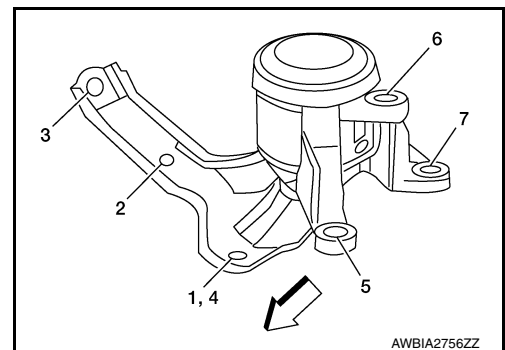

A
EM
C
D
E
F
G
H
I
J
K
L
M
N
O
P

ENGINE ASSEMBLY

< UNIT REMOVAL AND INSTALLATION >

8. Install upper torque rod as follows:

a. Tighten the bolts in sequence as shown to the specified torque.

↔ : Front

Bolts : 85 N·m (8.7 kg·m, 63 ft·lb)

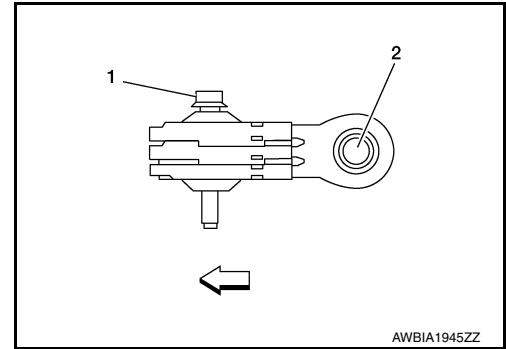

INSPECTION AFTER INSTALLATION

- Before starting engine, check oil/fluid levels including engine coolant and engine oil. If less than required quantity, fill to the specified level. Refer to [MA-16, "FOR USA AND CANADA : Fluids and Lubricants"](#) (United States and Canada) or [MA-17, "FOR MEXICO : Fluids and Lubricants"](#) (Mexico).
- Use procedure below to check for fuel leakage.
- Turn ignition switch ON (with engine stopped). With fuel pressure applied to fuel piping, check for fuel leakage at connection points.
- Start engine. With engine speed increased, check again for fuel leakage at connection points.
- Run engine to check for unusual noise and vibration.

NOTE:

If hydraulic pressure inside timing chain tensioner drops after removal and installation, slack in the guide may generate a pounding noise during and just after engine start. However, this is normal. Noise will stop after hydraulic pressure rises.

- Warm up engine thoroughly to make sure there is no leakage of fuel, exhaust gas, or any oils/fluids including engine oil and engine coolant.
- Bleed air from passages in lines and hoses, such as in cooling system.
- After cooling down engine, again check oil/fluid levels including engine oil and engine coolant. Refill to specified level, if necessary.
- Check wheel alignment. Refer to [FSU-7, "Inspection"](#).
- Adjust neutral position of steering angle sensor. Refer to [BRC-248, "Description"](#).
- Adjust control cable as necessary. Refer to [TM-85, "Inspection"](#).
- Summary of the inspection items:

Item		Before starting engine	Engine running	After engine stopped
Engine coolant		Level	Leakage	Level
Engine oil		Level	Leakage	Level
Transmission/ transaxle fluid	A/T and CVT Models	Leakage	Level/Leakage	Leakage
	M/T Models	Level/Leakage	Leakage	Level/Leakage
Other oils and fluids*		Level	Leakage	Level
Fuel		Leakage	Leakage	Leakage
Exhaust gas		—	Leakage	—

*Power steering fluid, brake fluid, etc.

CYLINDER BLOCK

< UNIT DISASSEMBLY AND ASSEMBLY >

UNIT DISASSEMBLY AND ASSEMBLY

CYLINDER BLOCK

Exploded View

INFOID:000000012233762

A

EM

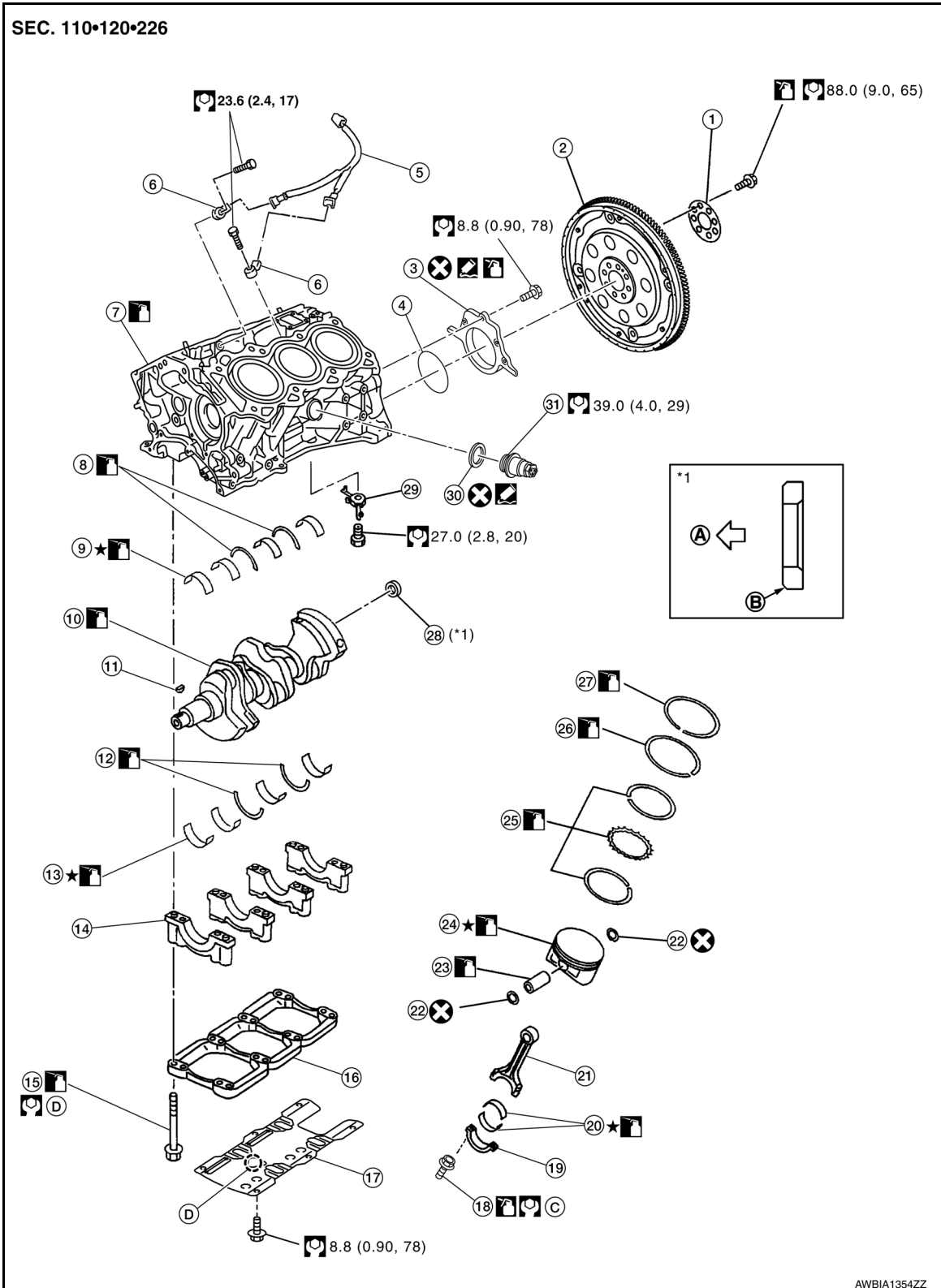

C

D

E

F

G

H

I

J

K

L

M

N

O

P

CYLINDER BLOCK

< UNIT DISASSEMBLY AND ASSEMBLY >

- | | | |
|--|----------------------------|----------------------------|
| 1. Reinforcement plate | 2. Drive plate | 3. Rear oil seal retainer |
| 4. Rear oil seal | 5. Sub harness | 6. Knock sensor |
| 7. Cylinder block | 8. Thrust bearing (upper) | 9. Main bearing (upper) |
| 10. Crankshaft | 11. Crankshaft key | 12. Thrust bearing (lower) |
| 13. Main bearing (lower) | 14. Main bearing cap | 15. Main bearing cap bolt |
| 16. Main bearing beam | 17. Baffle plate | 18. Connecting rod bolt |
| 19. Connecting rod bearing cap | 20. Connecting rod bearing | 21. Connecting rod |
| 22. Snap ring | 23. Piston pin | 24. Piston |
| 25. Oil ring | 26. Second ring | 27. Top ring |
| 28. Pilot converter | 29. Oil jet | 30. Gasket (for Canada) |
| 31. Cylinder block heater (for Canada) | A. Crankshaft side | B. Chamfered |
| C. Refer to INSTALLATION | D. Front mark | |

Disassembly and Assembly

INFOID:000000012233763

CAUTION:

- Apply new engine oil to parts as marked in illustrations before installation.
- Place removed parts such as bearings and bearing caps in their proper order and direction.
- When installing the connecting rod nuts and main bearing cap bolts, apply new engine oil to the threads and mating surfaces
- Do not allow any magnetic materials to contact the signal plate teeth on the drive plate.

DISASSEMBLY

1. Remove the engine assembly. Refer to [EM-107, "Removal and Installation"](#).
2. Remove the drive plate.
3. Remove pilot converter using suitable tool (A).

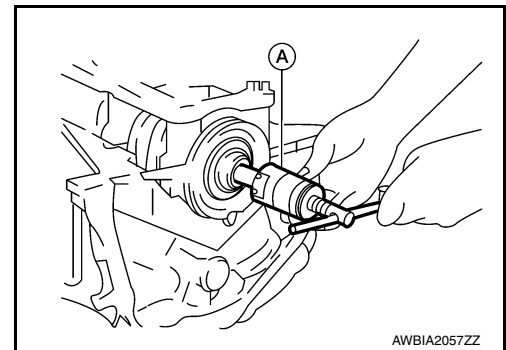

4. Cut away liquid gasket and remove rear oil seal retainer using suitable tool. Refer to [EM-5, "Precaution for Liquid Gasket"](#).

Tool number : KV10111100 (J-37228)

CAUTION:

- Be careful not to damage mounting surface.
- If rear oil seal retainer is removed, replace it with a new one.

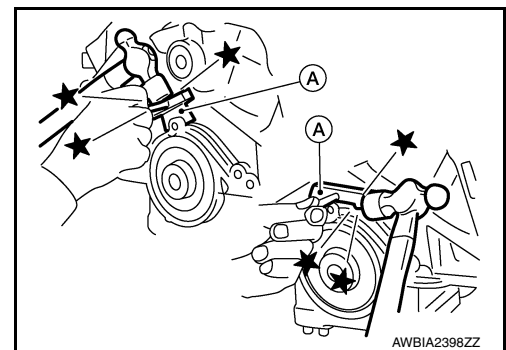

CYLINDER BLOCK

< UNIT DISASSEMBLY AND ASSEMBLY >

5. Install the engine on engine stand (A). Any commercially available engine stand (A) can be used.

CAUTION:

- Use an engine stand that has a load capacity [approximately 240kg (529 lb) or more] large enough for supporting the engine weight.
- Before removing the hanging chains, make sure the engine stand is stable and there is no risk of overturning.

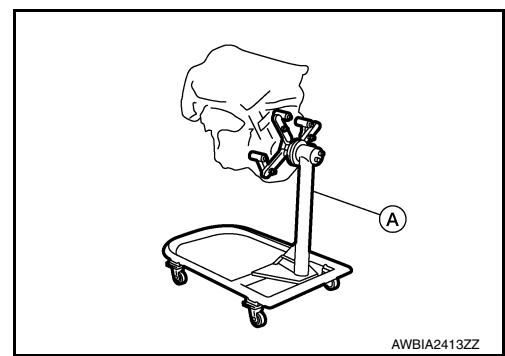

6. Remove the knock sensor.

CAUTION:

Carefully handle sensor to avoid shocking it.

7. Drain engine coolant. Refer to [CO-12. "Changing Engine Coolant"](#).
8. Drain engine oil. Refer to [LU-9. "Changing Engine Oil"](#).
9. Remove the upper oil pan. Refer to [EM-40. "Removal and Installation \(Upper Oil Pan\)"](#).
10. Remove the crankshaft pulley.
 - Use a suitable tool to prevent the crankshaft from turning.
11. Remove the timing chain. Refer to [EM-66. "Removal and Installation"](#).
12. Remove the cylinder head. Refer to [EM-91. "Removal and Installation"](#).

13. Remove the piston and connecting rod assemblies.

- a. Position the crankshaft pin corresponding to the connecting rod to be removed onto the bottom dead center.
- b. Remove the connecting rod cap.
- c. Using a suitable tool, push the piston and connecting rod assembly out to the cylinder head side.
 - Before removing the piston and connecting rod assembly, check the connecting rod side clearance. Refer to [EM-150. "Connecting Rod Bearing"](#).

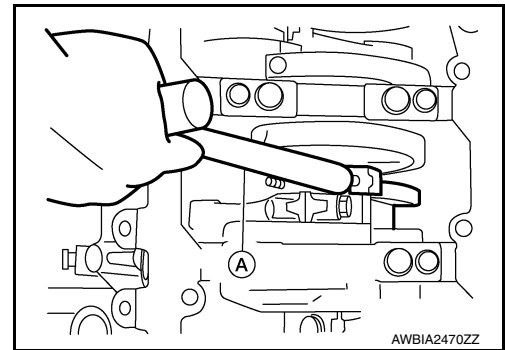

14. Remove the connecting rod bearings.

CAUTION:

- When removing the connecting rod side bearings, note the installation position. Keep them in the correct order.

15. Remove the piston rings from the piston.

- Use a piston ring expander (A).

CAUTION:

- When removing the piston rings, be careful not to damage the piston. Do not expand the rings excessively.
 - Be careful to mark the rings if they are to be reused so they are installed in their original position.
- Before removing the piston rings, check the piston ring side clearance. Refer to [EM-126. "Inspection"](#).

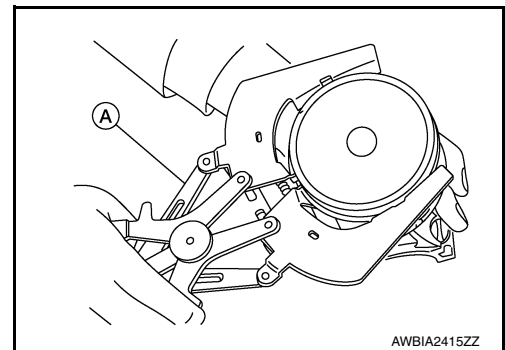

CYLINDER BLOCK

< UNIT DISASSEMBLY AND ASSEMBLY >

16. Remove the piston from the connecting rod as follows.

- a. Using a suitable tool (A), remove the snap ring.

CAUTION:

Do not reuse snap rings, always replace with new ones.

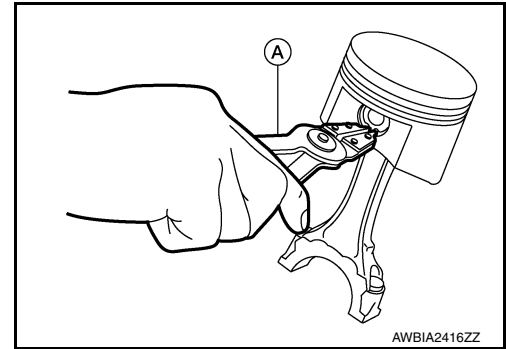

- b. Heat the pistons to 60° - 70°C (140° - 158°F). utilizing suitable tool (A)

WARNING:

Pistons contain heat. When working, wear protective equipment to avoid getting burned.

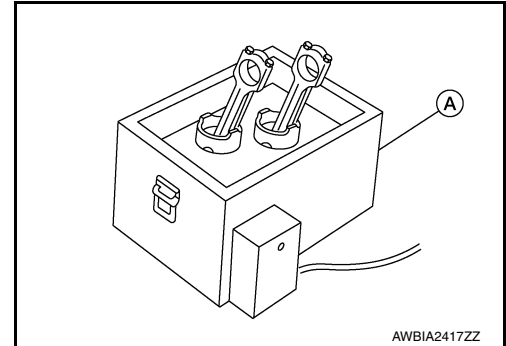

- c. Push out the piston pin with a suitable tool with an outer diameter of approximately 20 mm (0.8 in).

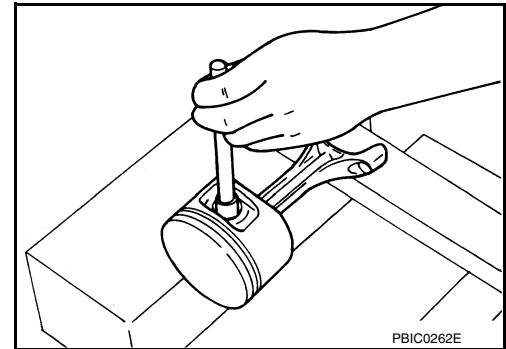

17. Remove the baffle plate from the main bearing beam.

18. Loosen the bolts in the reverse order shown and remove the main bearing beam, bearing caps and crankshaft.

- Before loosening the main bearing cap bolts, measure the crankshaft side clearance.

Refer to [EM-126. "Inspection"](#).

← : Engine front

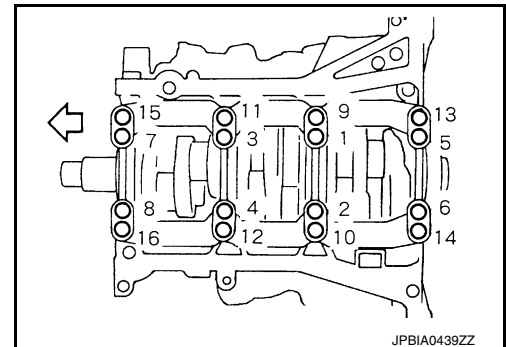

CYLINDER BLOCK

< UNIT DISASSEMBLY AND ASSEMBLY >

19. Remove the oil jets (A) and dowel pins.

← : Engine front

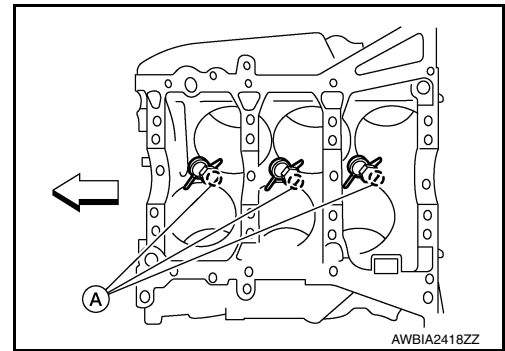

20. Remove the main bearings and thrust bearings from the cylinder block and main bearing caps.
• When removing them, note the direction and position. Keep them in the correct order for installation.

21. Remove the water drain plug (B) and (F), connector bolt (E), and copper sealing washer (A) and (G) on the cylinder block.

CAUTION:

- Do not reuse copper sealing washers.
- Do not reuse water drain plug O-ring (C).

NOTE:

For Canada, connector bolt (E) is a block heater, not a water drain plug.

← : Front

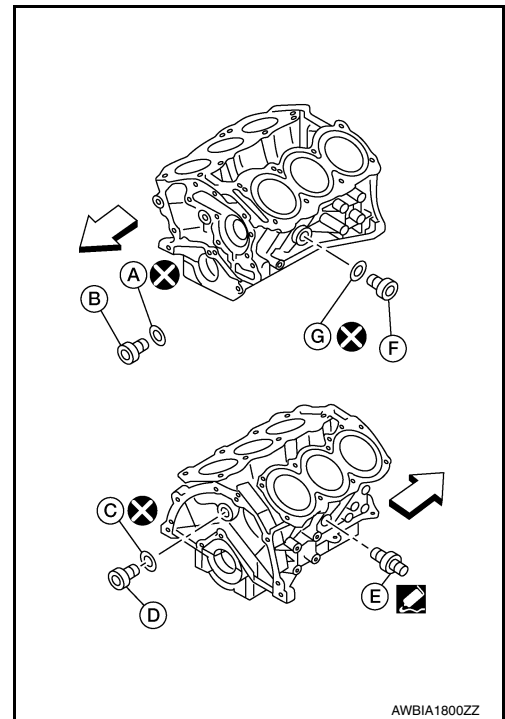

ASSEMBLY

1. Blow out the coolant and oil passages and cylinder bore to remove any foreign materials.

CAUTION:

Use goggles to protect your eyes.

CYLINDER BLOCK

< UNIT DISASSEMBLY AND ASSEMBLY >

2. Install the cylinder block drain plugs.
 - Install the water drain plug (B) and (F), connector bolt (E), and copper sealing washer (A) and (G) on the cylinder block.
 - Install water drain plug (D) and copper sealing washer (C) during engine overhaul.
 - Tighten each plug and connector bolt to specifications.

Water drain plug (B) : 62.0 N·m (6.3 kg-m, 46 ft-lb)

Water drain plug (D) : 78.0 N·m (8.0 kg-m, 58 ft-lb)

Connector Bolt (E) : 27.0 N·m (2.8 kg-m, 20 ft-lb)

Water drain plug (F) : 6.0 N·m (0.61 kg-m, 53 in-lb)

CAUTION:

- Use **Genuine High Performance Thread Sealant or equivalent. Refer to [GI-22, "Recommended Chemical Products and Sealants"](#).**
- **Do not reuse copper sealing washers.**
- **Installation should be done within 5 minutes of applying liquid gasket.**
- **Do not fill the engine with engine coolant for at least 30 minutes after the components are installed to allow the sealant to cure.**

⇐ : Front

3. Install the oil jets (A).
 - Insert the oil jet dowel pin into the cylinder block dowel pin hole, and tighten the bolts.

⇐ : Engine front

4. Install the main bearings and the thrust bearings (C).
 - a. Remove dust, dirt, and oil on the bearing mating surfaces of the cylinder block and the main bearing cap.
 - b. Install the thrust bearings (C) to both sides (D) of the No. 3 journal housing on the cylinder block (A) and the main bearing cap.
 - Install the thrust bearings (C) with the oil groove facing the crankshaft arm (outside).
 - Install bearing with a projection on one end on cylinder block and bearing with a projection at center on cap. Align each projection with mating notch.

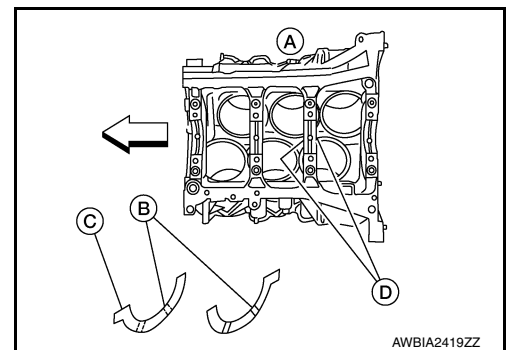
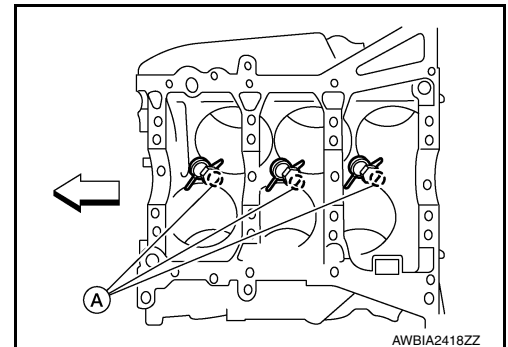
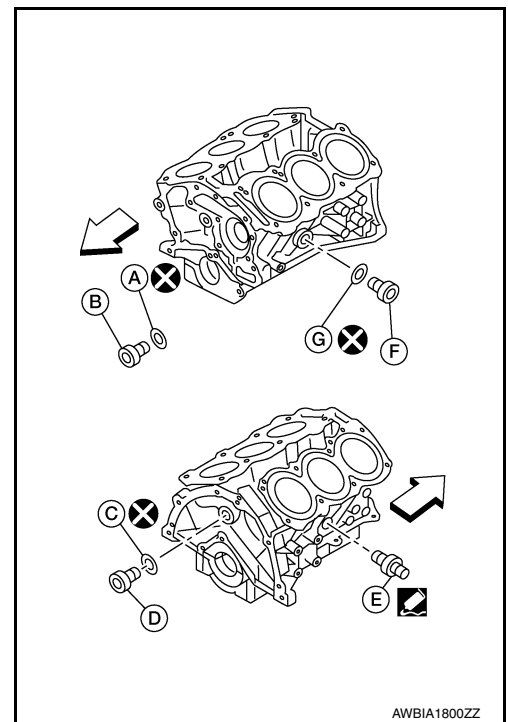

CYLINDER BLOCK

< UNIT DISASSEMBLY AND ASSEMBLY >

5. Set the upper main bearings (A) and lower main bearings (B) in their proper positions on the cylinder block.
 - Confirm the correct main bearings are used. Refer to [EM-126](#), "Inspection".

↶ : Engine front

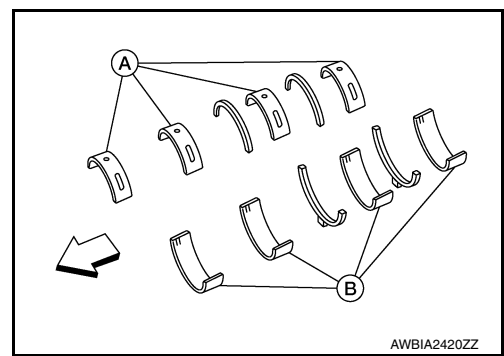

6. Instructions for the re-use of the main bearing cap bolts.
 - A plastic zone tightening method is used for tightening the main bearing cap bolts. Measure (d1) and (d2) as shown.
 - For (d2), select the minimum diameter in the measuring area.
 - If the difference between (d1) and (d2) exceeds the limit, replace the bolts for assembly.

Limit (d1 - d2) : 0.11 mm (0.0043 in)

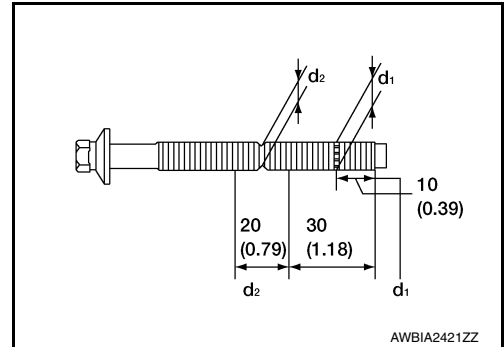

7. After installing the crankshaft, lower main bearings, main bearing caps, main bearing beam, and bearing cap bolts. Tighten the bearing cap bolts in the numerical order as shown.

↶ : Engine front

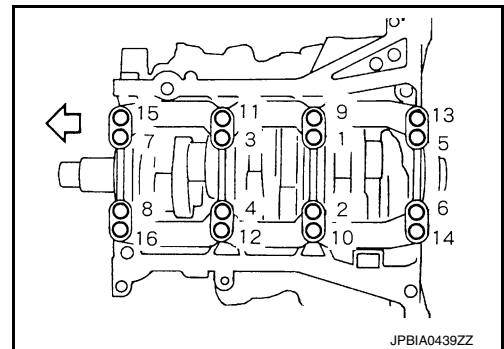

- a. Make sure that the front marks on the main bearing beam faces the front of the engine.
- b. Prior to tightening all the bearing cap bolts, place the bearing beam in its proper position by shifting the crankshaft in the axial position.
- c. After tightening the bearing cap bolts, make sure the crankshaft turns smoothly.
- d. Lubricate the threads and seat surfaces of the bolts with new engine oil.
- e. Tighten the bolts in two stages:

CAUTION:

Measure the tightening angle in two stages using Tool (A). Do not measure with eyes only, be sure to use Tool.

Stage 1 : 32.3 - 38.3 N·m (3.3 - 3.9 kg·m, 24 - 28 ft·lb)

Stage 2 : 90° - 95° degrees clockwise

Tool number : KV10112100 (BT-8653-A)

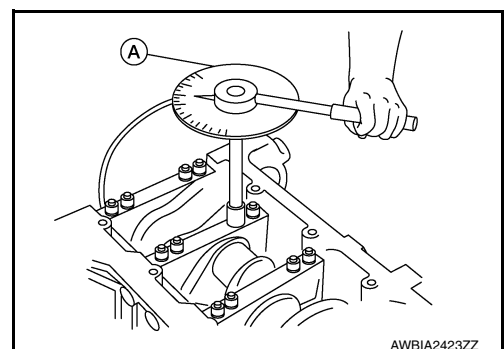
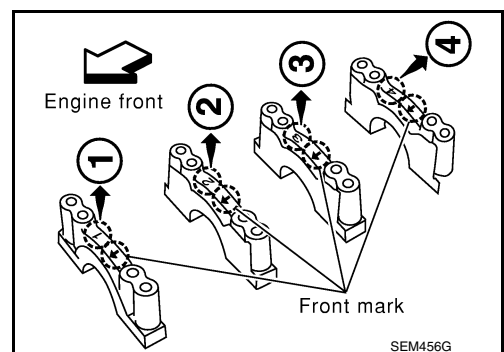

CYLINDER BLOCK

< UNIT DISASSEMBLY AND ASSEMBLY >

8. Measure crankshaft end play.
- If beyond the limit, replace the thrust bearing with a new one.
Refer to [EM-146, "Cylinder Block"](#).

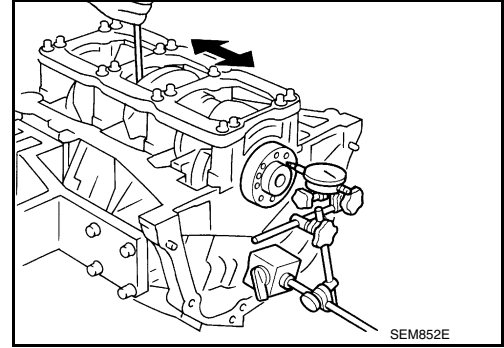

9. Install the piston to the connecting rod.
- a. Using suitable snap ring pliers, install the snap ring fully into the pin-groove of the piston rear side.

CAUTION:

Do not reuse snap rings.

- (A) : Piston front mark
- (B) : Oil hole
- (C) : Connecting rod front mark
- (D) : Cylinder No.

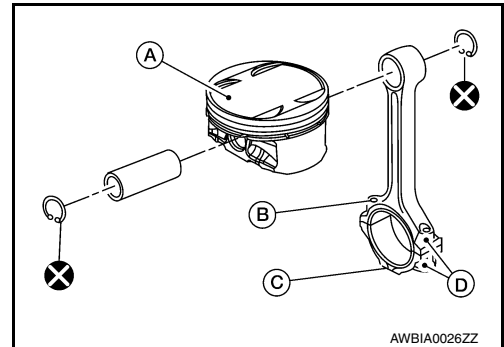

- b. Install the piston to the connecting rod.
- Heat the piston using suitable tool (A) until the piston pin can be pushed in by hand without excess force [approximately 60 - 70°C (140 - 158°F)]. From the front to the rear, insert the piston pin into the piston and through the connecting rod.

WARNING:

Pistons contain heat. When working, wear protective equipment to avoid getting burned.

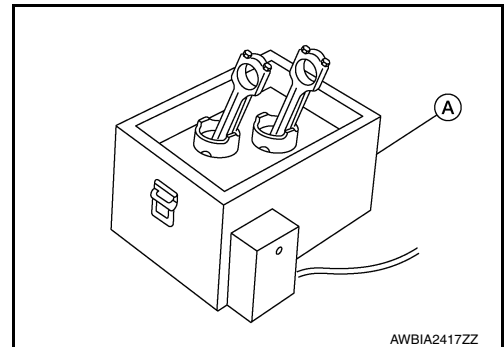

CYLINDER BLOCK

< UNIT DISASSEMBLY AND ASSEMBLY >

- Assemble so that the piston front mark (B) and the crown and the oil hole (D), connecting rod front mark (G) and cylinder No. (H) on the connecting rod are positioned as shown.

- ← : Engine front
- (A) : Piston grade number
- (B) : Piston front mark
- (C) : Pin grade
- (D) : Crown and oil hole
- (E) : Small end grade number
- (F) : Mass grade number
- (G) : Connecting rod front mark
- (H) : Cylinder No.
- (J) : Crown I.D. code

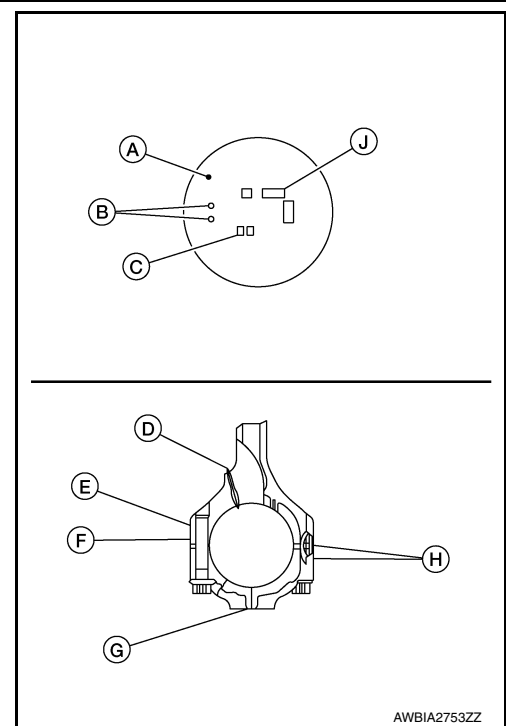

- c. Install the snap ring (A) into the front of the piston pin-groove.
- After installing, check that the connecting rod pivots smoothly on the pin.

CAUTION:

Do not reuse snap rings, always replace with new ones.

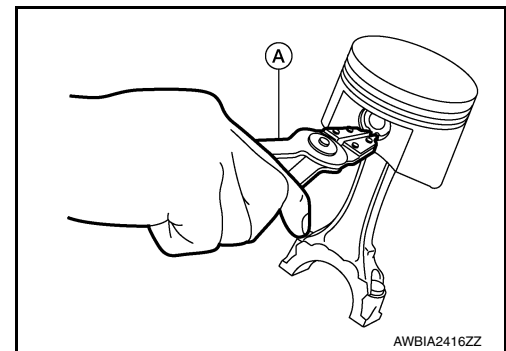

10. Using a piston ring expander, install the piston rings.

- (A) : Top ring
- (B) : Second ring

CAUTION:

- Be careful not to damage the piston.
- When the piston rings are not replaced, remount the rings in their original positions.
- When replacing the piston rings, those without stamped surface (A) can be mounted either side up.
- Install the second ring with the stamped surface (B) facing upward. If the ring is not stamped it can face in either direction.

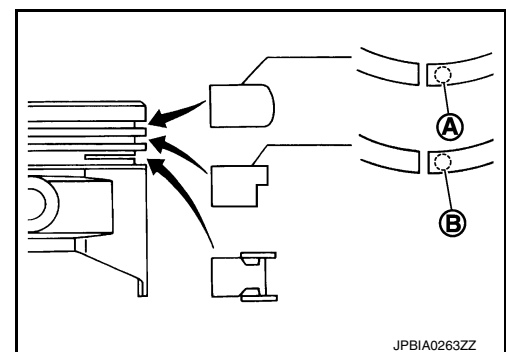

A
EM
C
D
E
F
G
H
I
J
K
L
M
N
O
P

CYLINDER BLOCK

< UNIT DISASSEMBLY AND ASSEMBLY >

- Position each ring with the gap as shown, referring to the piston front mark.

- (A) : Top ring gap
- (B) : Front mark
- (C) : Oil ring upper or lower rail gap
- (D) : Second ring and oil ring spacer gap
- (E) : Oil ring upper or lower rail gap

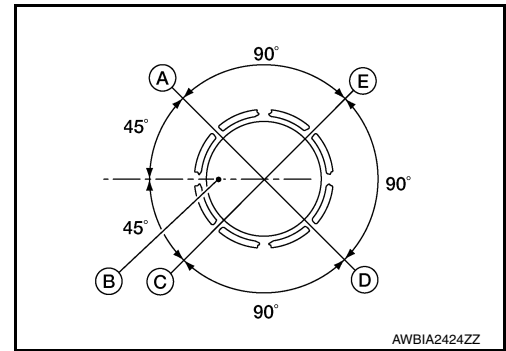

11. Install the connecting rod bearings (A) to the connecting rod and the connecting rod cap (B).

- When installing the connecting rod bearings (A), apply engine oil to the bearing surface (crankshaft side). Do not apply oil to the back surface (connecting rod and cap side), but thoroughly clean it.
- When installing, align the connecting rod bearing (A) protrusion with the notch of the connecting rod to install.
- Check that the oil holes on the connecting rod (B) and on the corresponding bearing (A) are aligned.

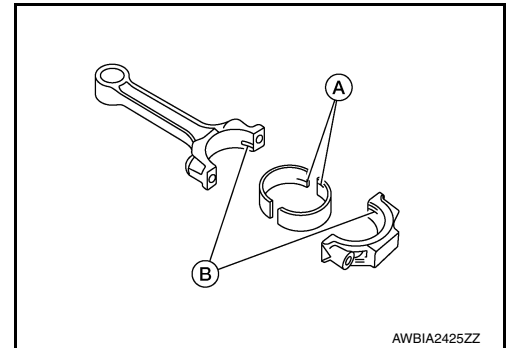

12. Install the piston and connecting rod assembly into the corresponding cylinder.

- Position the crankshaft pin corresponding to the connecting rod to be installed onto the bottom dead center.
- Apply engine oil sufficiently to the cylinder bore, piston, and crankshaft pin.
- Match the cylinder position with the cylinder No. (B) on the connecting rod to install.
- Install the piston with the piston front mark (A) on the crown facing the front of the engine (↔) using a suitable tool.

- (C) : Oil hole

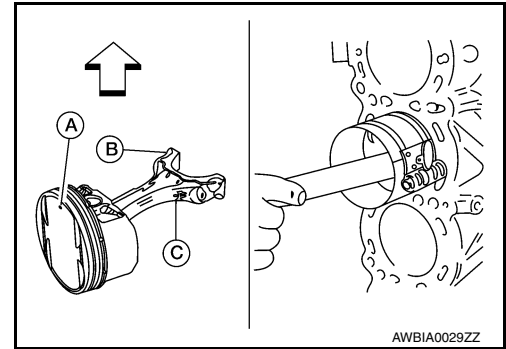

CAUTION:

Be careful not to damage the crankshaft pin and cylinder wall, resulting from interference of the connecting rod big end.

13. Install the connecting rod cap.

- Observing the sample codes (A), match the stamped cylinder number marks (F) on the connecting rod with those on the cylinder cap for installation.
- Install the piston connecting rod assembly and cap so that the front mark on the cap and piston are facing the front of the engine.
- Lubricate the threads and seat surfaces with new engine oil.**

- (B) : Small end diameter grade
- (C) : Weight grade
- (D) : Management code
- (E) : Front mark

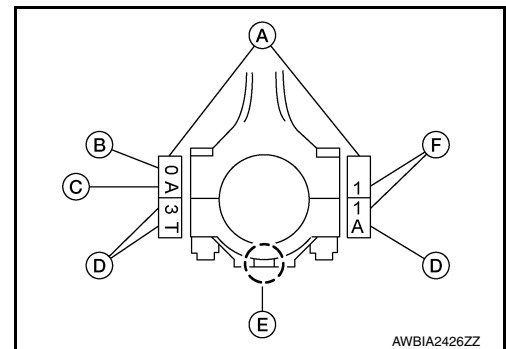

CYLINDER BLOCK

< UNIT DISASSEMBLY AND ASSEMBLY >

14. Check the connecting rod cap bolts before reusing, then install in their original position in the connecting rod. The bolts should screw in smoothly by hand.
- Measure the outer diameter of the connecting rod cap bolt as shown.

Outer diameter (d) of the connecting rod bolt
Standard : 7.90 - 8.00 mm (0.3110 - 0.3150 in)
Limit : 7.75 mm (0.3051 in)
(A) : 19 mm (0.75 in)

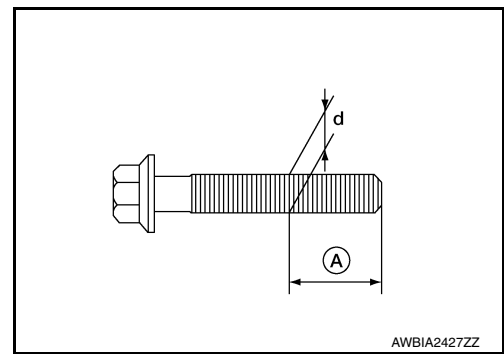

15. Tighten the connecting rod nuts in two stages using Tool:

Stage 1 : 19 - 21 N·m (1.9 - 2.1 kg-m, 14 - 15 ft-lb)
Stage 2 : 90° - 95° degrees clockwise

CAUTION:

Always use either an angle wrench or protractor. Avoid tightening based on visual check alone.

Tool number : KV10112100 (BT-8653-A)

- Apply engine oil to the threads and seats of the connecting rod bolts and nuts.
- After tightening the nuts, make sure that the crankshaft rotates smoothly.
- Check the connecting rod side clearance. If beyond the limit, replace the connecting rod and/or crankshaft. Refer to [EM-146, "Cylinder Block"](#).

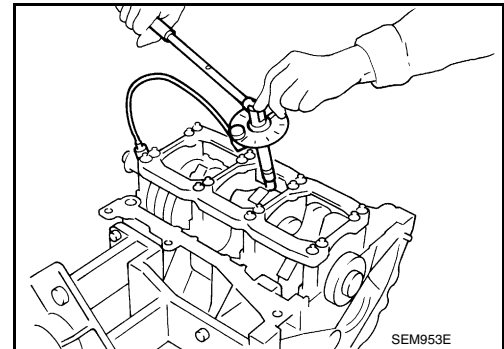

16. Install the baffle plate to the main bearing beam.

17. Install the knock sensor (A).

- Make sure that there is no foreign material on the cylinder block mating surface and the back surface of the knock sensor (A).
- Install the knock sensor (A) with the connector facing the rear of the engine.
- Do not tighten the bolts while holding the connector.
- Make sure that the knock sensor (A) does not interfere with other parts.

⇐ : Engine front

CAUTION:

If any impact by dropping occurs to the knock sensor, replace it with new one.

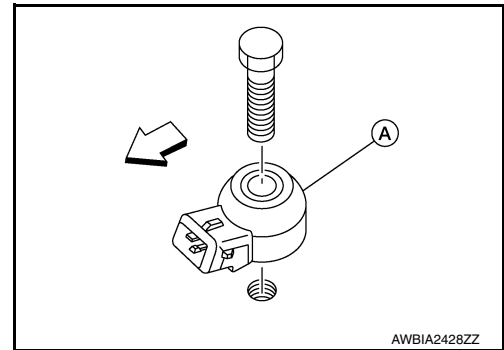

18. Install the cylinder head. Refer to [EM-91, "Removal and Installation"](#).

19. Install the timing chain. Refer to [EM-66, "Removal and Installation"](#).

20. Install the oil pan. Refer to [EM-39, "Removal and Installation \(Lower Oil Pan\)"](#) and [EM-40, "Removal and Installation \(Upper Oil Pan\)"](#).

21. Remove the engine from the stand.

CYLINDER BLOCK

< UNIT DISASSEMBLY AND ASSEMBLY >

22. Install the pilot converter with its chamfer facing crankshaft as shown.

⇐ : Crankshaft side

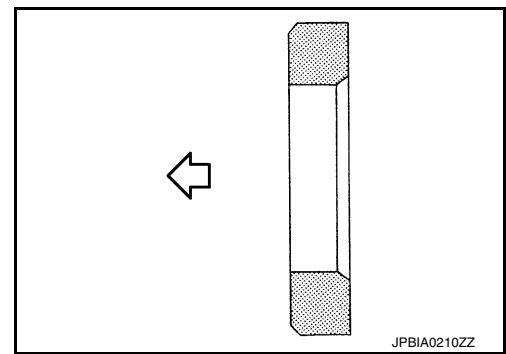

23. Install the rear oil seal retainer using Tool (A).

Tool number : — (J-47128)

- Loosen the wing nut (B) on the end of the Tool (A).
- Insert the arbor (D) into the crankshaft pilot hole until the outer lip (C) of the Tool (A) covers the edge of the crankshaft sealing surface.
- Tighten the wing nut (B) to secure the Tool (A) to the crankshaft.

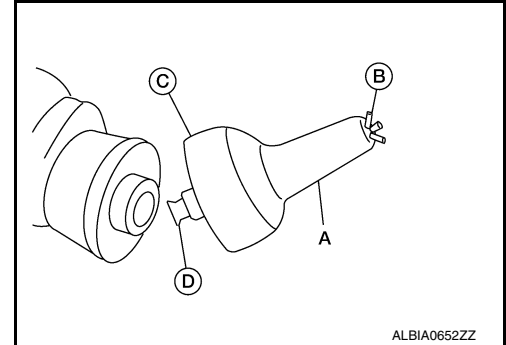

- Apply sealant to rear oil seal retainer as shown. **Use Genuine Silicone RTV Sealant, or equivalent. Refer to [GI-22, "Recommended Chemical Products and Sealants"](#).**

CAUTION:

- Installation should be done within 5 minutes after applying liquid gasket.
- Do not fill the engine with oil for at least 30 minutes after the components are installed to allow the sealant to cure.

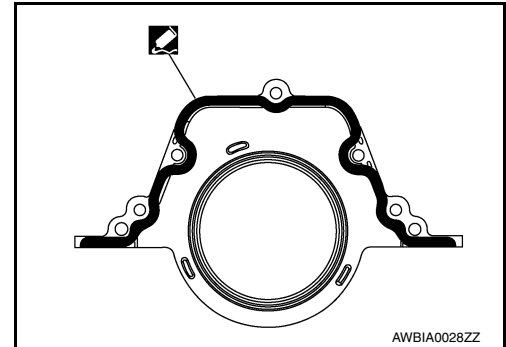

- Lubricate the sealing surface of the new rear main seal with new engine oil.
- Slide the new rear main seal (1) over the Tool (A) and onto the crankshaft.
- Loosen the wing nut and push the threaded rod into the handle to remove the Tool (A).
- Tighten the rear oil seal retainer bolts to specification. Refer to [EM-115, "Exploded View"](#).

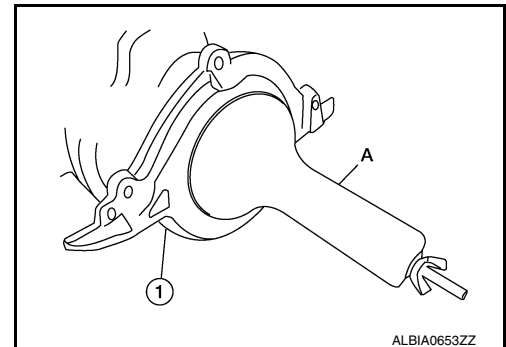

24. Install the drive plate. Refer to [EM-115, "Exploded View"](#).

25. Install the engine assembly into the vehicle. Refer to [EM-107, "Removal and Installation"](#).

Inspection

INFOID:000000012233764

PISTON AND PISTON PIN CLEARANCE

Inner Diameter of Piston Pin Hole

CYLINDER BLOCK

< UNIT DISASSEMBLY AND ASSEMBLY >

- Measure the inner diameter of piston pin hole (dp). Refer to [EM-146, "Cylinder Block"](#).

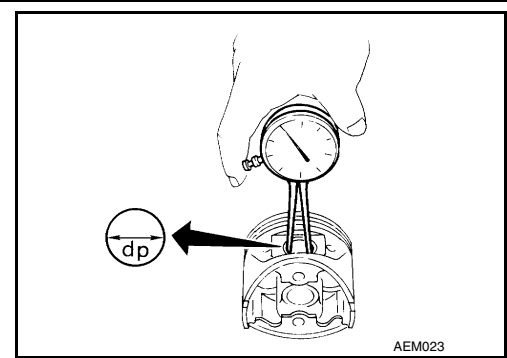

Outer Diameter of Piston Pin

- Measure outer diameter of piston pin (Dp). Refer to [EM-146, "Cylinder Block"](#).

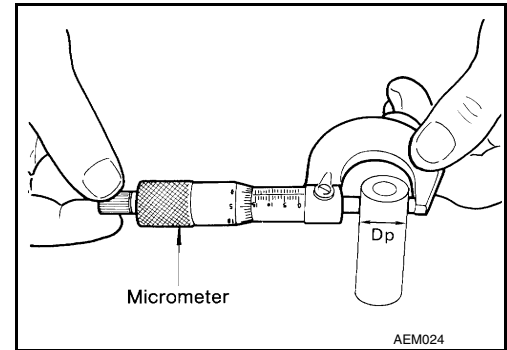

- ◀ : Engine front
- (A) : Piston grade number
- (B) : Piston front mark
- (C) : Pin grade
- (D) : Crown and oil hole
- (E) : Small end grade number
- (F) : Mass grade number
- (G) : Connecting rod front mark
- (H) : Cylinder No.
- (J) : Crown I.D. code

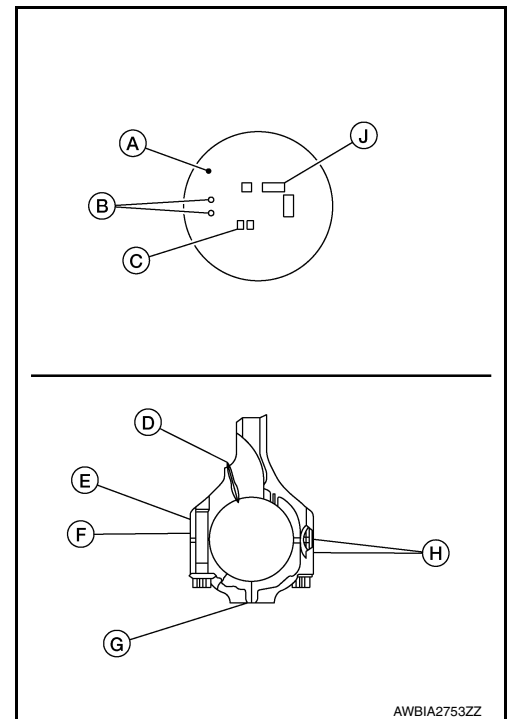

Piston and Piston Pin Interference Fit
 Standard Interference Fit = (Dp) – (dp)

Standard : 0.002 – 0.010 mm (0.0001 – 0.0004 in)

- If clearance exceeds specification, replace either or both of piston/piston pin assembly and connecting rod assembly with reference to specification of each part.

PISTON RING SIDE CLEARANCE

A
EM
C
D
E
F
G
H
I
J
K
L
M
N
O
P

CYLINDER BLOCK

< UNIT DISASSEMBLY AND ASSEMBLY >

- Measure side clearance of piston ring and piston ring groove with feeler gauge.
- If out of specification, replace piston ring assembly. If clearance exceeds maximum limit with new rings, replace piston. Refer to [EM-146, "Cylinder Block"](#).

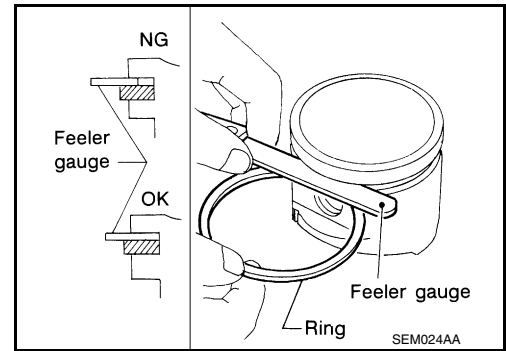

PISTON RING END GAP

- Insert piston ring until it is in the middle of the cylinder bore and measure the end gap.
- If out of specification, replace piston ring. Refer to [EM-146, "Cylinder Block"](#).

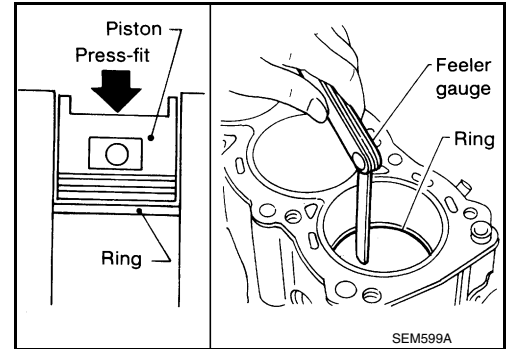

CONNECTING ROD BEND AND TORSION

- If it exceeds the limit, replace connecting rod assembly. Refer to [EM-146, "Cylinder Block"](#).

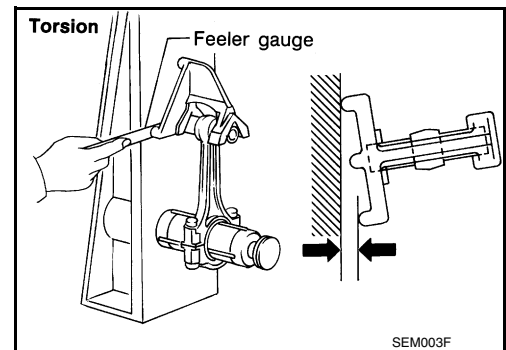
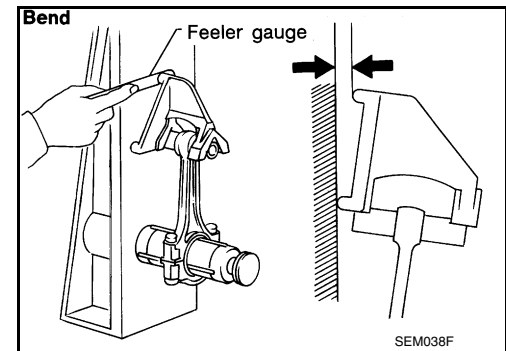

CONNECTING ROD BEARING HOUSING DIAMETER (BIG END)

- Install the connecting rod cap without the connecting rod bearing installed. After tightening the connecting rod nut to the specified torque, measure the connecting rod bearing housing big end inner diameter using an inside micrometer. Refer to [EM-146, "Cylinder Block"](#).

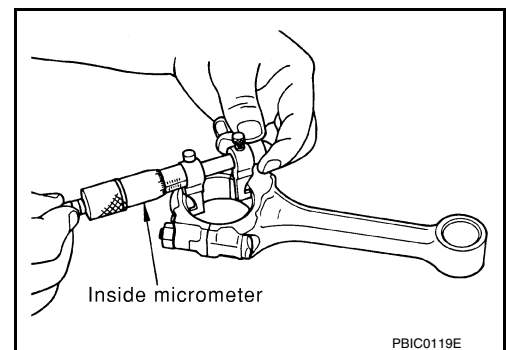

CYLINDER BLOCK

< UNIT DISASSEMBLY AND ASSEMBLY >

CONNECTING ROD BUSHING OIL CLEARANCE (SMALL END)

Inner Diameter of Connecting Rod (Small End)

- Measure inner diameter of piston pin bushing. Refer to [EM-146](#). "[Cylinder Block](#)".

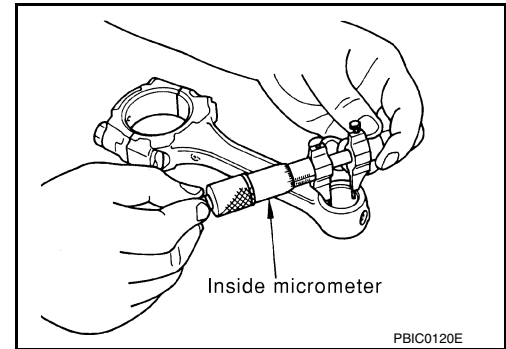

Outer Diameter of Piston Pin

- Measure outer diameter of piston pin. Refer to [EM-146](#). "[Cylinder Block](#)".

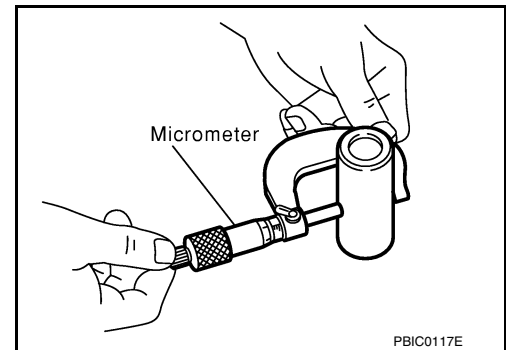

Connecting Rod Bushing Oil Clearance (Small End)

(Connecting rod small end oil clearance) = (Inner diameter of connecting rod small end) – (Outer diameter of piston pin). Refer to [EM-146](#). "[Cylinder Block](#)".

- If the measured value exceeds the standard, replace the connecting rod assembly and/or piston and piston pin assembly.
- If replacing the piston and piston pin assembly, use the Table for Selective Fitting for Piston to select the piston corresponding to the applicable bore grade of the cylinder block to be used. Follow the "PISTON-TO-CYLINDER BORE CLEARANCE" procedure.

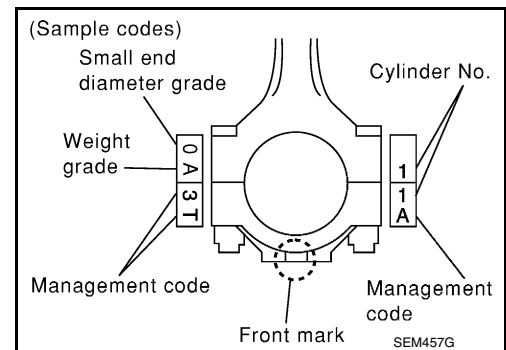

Factory installed parts grading:

CYLINDER BLOCK

< UNIT DISASSEMBLY AND ASSEMBLY >

- ⇐ : Engine front
- (A) : Piston grade number
- (B) : Piston front mark
- (C) : Pin grade
- (D) : Crown and oil hole
- (E) : Small end grade number
- (F) : Mass grade number
- (G) : Connecting rod front mark
- (H) : Cylinder No.
- (J) : Crown I.D. code

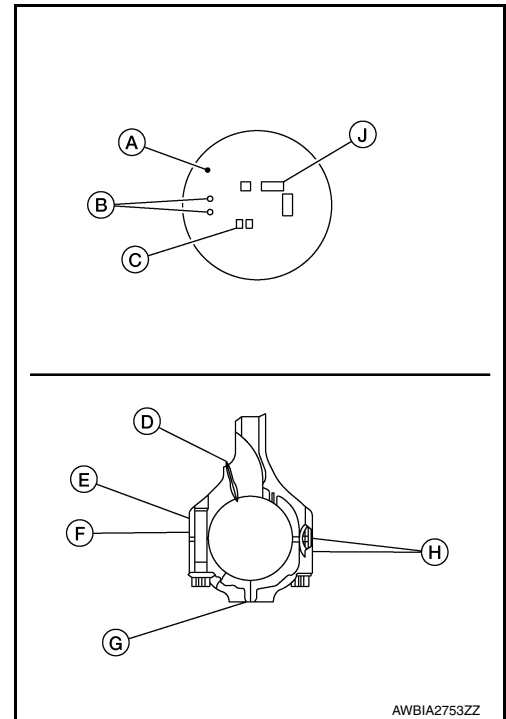

Service parts apply only to grade 0.

Unit: mm (in)

Grade	0	1
Connecting rod small end inner diameter	22.000 - 22.006 (0.8661 - 0.8664)	22.006 - 22.012 (0.8664 - 0.8666)
Piston pin outer diameter	21.989 - 21.995 (0.8657 - 0.8659)	21.995 - 22.001 (0.8659 - 0.8662)
Piston pin hole diameter	21.993 - 21.999 (0.8659 - 0.8661)	21.999 - 22.005 (0.8661 - 0.8663)

CYLINDER BLOCK DISTORTION

- Using a scraper, remove any old gasket material on the cylinder block surface and remove any oil, scale, carbon, or other contamination.

CAUTION:

Be careful not to allow gasket flakes to enter the oil or coolant passages.

- Measure the distortion on the block upper face at different points in six directions. Refer to [EM-146. "Cylinder Block"](#).
- If out of specification, resurface the cylinder block. The allowable amount of resurfacing is dependent on the amount of any cylinder head resurfacing. The resurfacing limit is [amount of cylinder head resurfacing] + [amount of cylinder head resurfacing] = 0.2 mm (0.008 in).

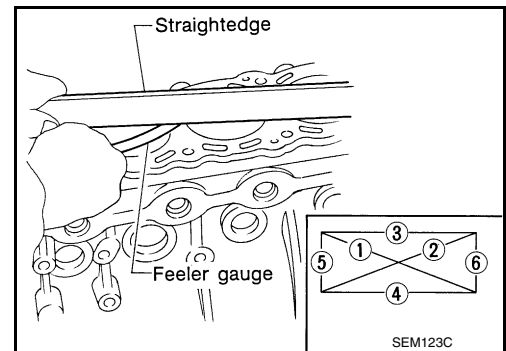

**Cylinder block height : 214.95 - 215.05 mm
(8.4626 - 8.4665 in)**

INNER DIAMETER OF MAIN BEARING HOUSING

- Install the main bearing caps with the main bearings removed, and tighten the bolts to the specified torque.

CYLINDER BLOCK

< UNIT DISASSEMBLY AND ASSEMBLY >

- Using a bore gauge, measure the inner diameter of the main bearing housing (A). Refer to [EM-146, "Cylinder Block"](#).
- If out of the standard, replace the cylinder block and main bearing caps as an assembly.

NOTE:

These components cannot be replaced as a single unit, because they were processed together.

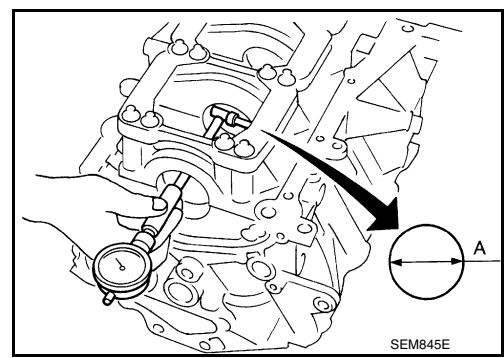

PISTON-TO-CYLINDER BORE CLEARANCE

- Using a bore gauge, measure cylinder bore for wear, out-of-round and taper at (A), (B) and (C). The X axis is in the longitudinal direction of the engine.

Cylinder bore inner diameter

Grade No.	Standard inner diameter	Wear limit
No. 1	95.500 - 95.510 mm (3.7598 - 3.7602 in)	0.20 mm (0.0079 in)
No. 2	95.510 - 95.520 mm (3.7602 - 3.7606 in)	
No. 3	95.520 - 95.530 mm (3.7606 - 3.7610 in)	

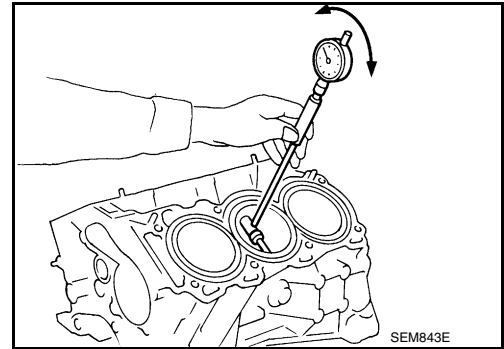

If it exceeds the limit, rebore all cylinders. Replace cylinder block if necessary. Refer to [EM-146, "Cylinder Block"](#).

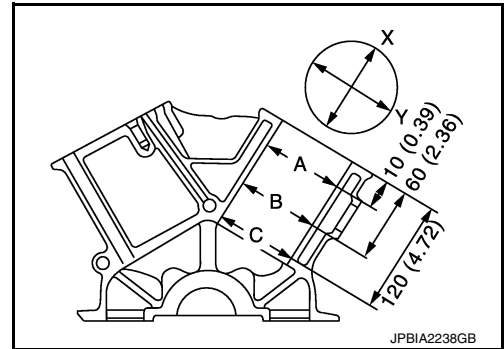

- Check for scratches and seizure. If seizure is found, hone it.
 - If both cylinder block and piston are replaced with new ones, select piston of the same grade number punched on cylinder block rear position. These numbers are punched in either Arabic or Roman numerals.

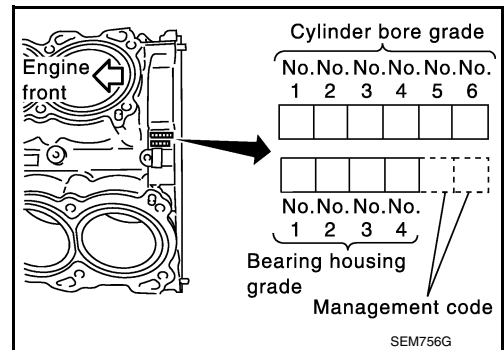

CYLINDER BLOCK

< UNIT DISASSEMBLY AND ASSEMBLY >

3. Measure piston skirt diameter. Refer to [EM-146. "Cylinder Block"](#).

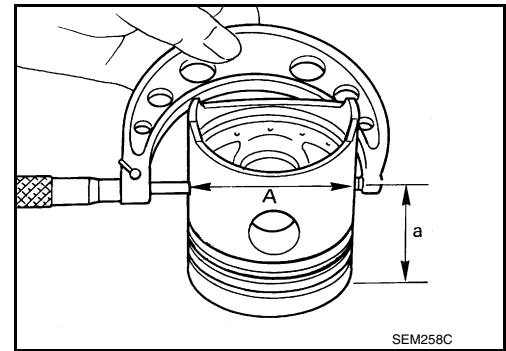

4. Check that piston-to-bore clearance is within specification. Refer to [EM-146. "Cylinder Block"](#).
- The piston-to-bore clearance is measured at the (B) level in the cylinder as shown.

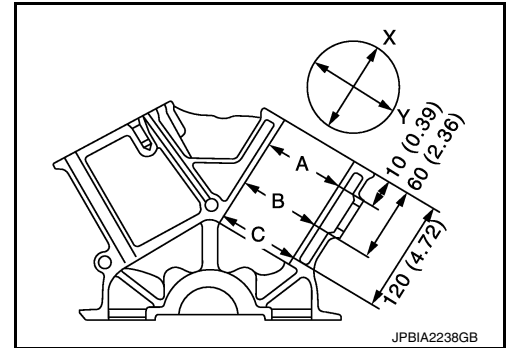

5. Cylinder bore size is determined by adding piston-to-bore clearance to piston diameter (A).

Rebored size calculation : $D = A + B - C$

where,

- (D) : Bored diameter
 (A) : Piston diameter as measured
 (B) : Piston-to-bore clearance
 (C) : Honing allowance 0.02 mm (0.0008 in)

6. Install main bearing caps, and tighten to the specified torque. Otherwise, cylinder bores may be distorted after boring.
7. Cut cylinder bores.
- When any cylinder needs boring, all other cylinders must also be bored.**
 - Do not cut too much out of cylinder bore at a time. Cut only 0.05 mm (0.0020 in) or so in diameter at a time.**
8. Hone cylinders to obtain specified piston-to-bore clearance.
9. Measure finished cylinder bore for out-of-round and taper.
- Measurement should be done after cylinder bore cools down.**

CRANKSHAFT

1. Check the crankshaft main and pin journals for scoring, wear, or cracks.
2. Measure the journals for taper and out-of-round. Refer to [EM-146. "Cylinder Block"](#).

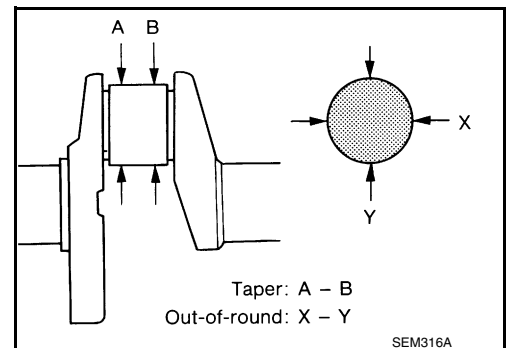

CYLINDER BLOCK

< UNIT DISASSEMBLY AND ASSEMBLY >

3. Measure crankshaft runout.
 - a. Place a V-block on a precise flat table to support the journals on the both ends of the crankshaft.
 - b. Place a dial gauge straight up on the No. 3 journal.
 - c. While rotating the crankshaft, read the movement of the pointer on the dial gauge. Refer to [EM-146. "Cylinder Block"](#).

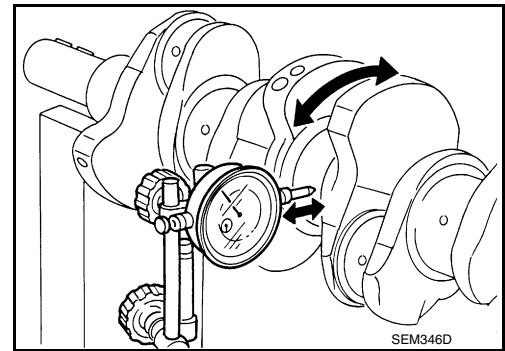

BEARING CLEARANCE

- Use either of the following two methods, however method (A) gives more reliable results and so is the preferred method.

Method A (Using Bore Gauge and Micrometer)

Main Bearing

1. Set the main bearings in their proper positions on the cylinder block and the main bearing cap.
2. Install the main bearing caps and bearing beam to the cylinder block. Tighten all bolts in the numerical order as specified. Refer to [EM-116. "Disassembly and Assembly"](#).

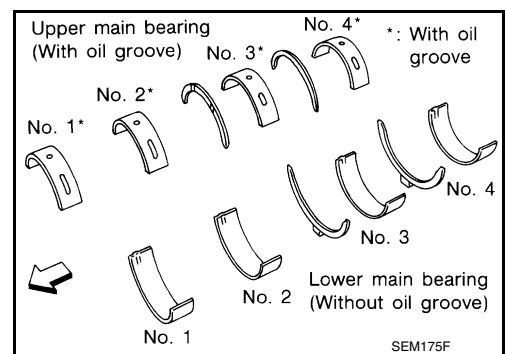

3. Measure the inner diameters (A) of each main bearing as shown.

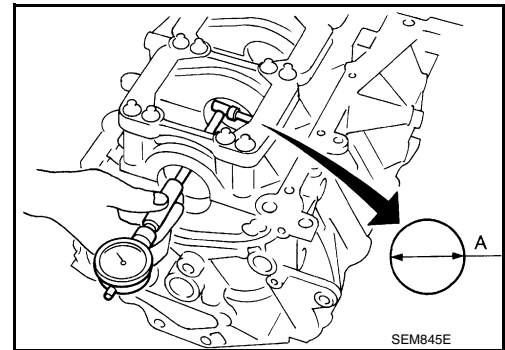

4. Measure the outer diameters (Dm) of each crankshaft main journal as shown.
5. Calculate the main bearing clearance. Refer to [EM-149. "Main Bearing"](#).
 - If it exceeds the limit, replace the bearing.
 - If clearance cannot be adjusted using any standard bearing grade, grind crankshaft journal and use an undersized bearing.

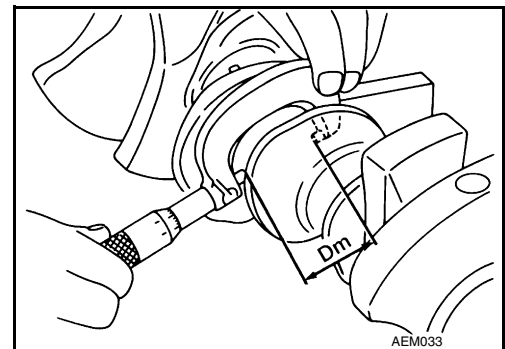

CYLINDER BLOCK

< UNIT DISASSEMBLY AND ASSEMBLY >

- When grinding the crankshaft journal, confirm that the (L) dimension in the fillet role is more than the specified limit. Refer to [EM-146. "Cylinder Block"](#).

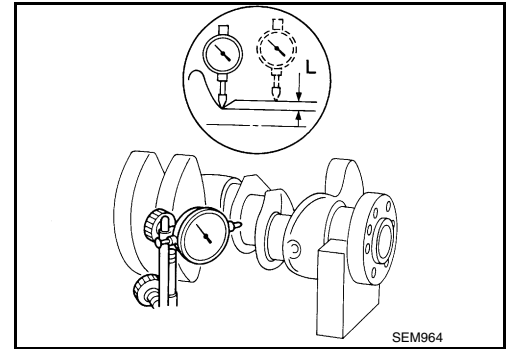

6. If the crankshaft or the cylinder block is replaced with a new one, select thickness of the main bearings as follows:

- a. The grade number of each cylinder block main journal is punched on the respective cylinder block. These numbers are punched in either Arabic or Roman numerals. If measured diameter is out of the grade punched, decide suitable grade from available main bearings.

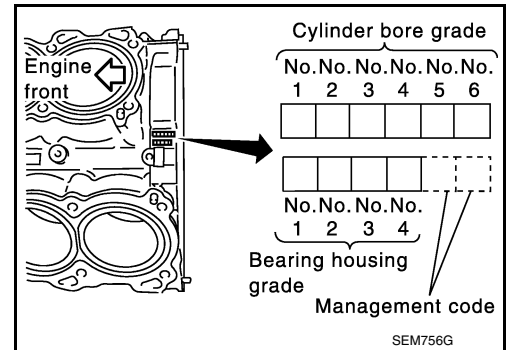

- b. The grade number of each crankshaft main journal is punched on the crankshaft end. These numbers are punched in either Arabic or Roman numerals. If measured diameter is out of grade punched, decide the suitable grade from available main bearings.

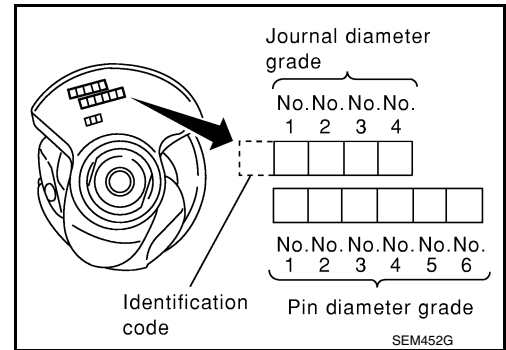

CYLINDER BLOCK

< UNIT DISASSEMBLY AND ASSEMBLY >

c. Select the main bearing suitable thickness according to the following table:

Mark	Axle diameter Unit: mm (in)	Cylinder block bearing housing inner diameter Unit: mm (in)																											
		Hole diameter																											
Mark	Axle diameter	A	B	C	D	E	F	G	H	J	K	L	M	N	P	R	S	T	U	V	W	X	Y	4	7				
		63.993 - 63.994 (2.5194 - 2.5194)	63.994 - 63.995 (2.5194 - 2.5195)	63.995 - 63.996 (2.5195 - 2.5195)	63.996 - 63.997 (2.5195 - 2.5196)	63.997 - 63.998 (2.5196 - 2.5196)	63.998 - 63.999 (2.5196 - 2.5196)	63.999 - 64.000 (2.5196 - 2.5197)	64.000 - 64.001 (2.5197 - 2.5197)	64.001 - 64.002 (2.5197 - 2.5198)	64.002 - 64.003 (2.5198 - 2.5198)	64.003 - 64.004 (2.5198 - 2.5198)	64.004 - 64.005 (2.5199 - 2.5199)	64.005 - 64.006 (2.5199 - 2.5199)	64.006 - 64.007 (2.5199 - 2.5200)	64.007 - 64.008 (2.5200 - 2.5200)	64.008 - 64.009 (2.5200 - 2.5200)	64.009 - 64.010 (2.5200 - 2.5201)	64.010 - 64.011 (2.5201 - 2.5201)	64.011 - 64.012 (2.5201 - 2.5202)	64.012 - 64.013 (2.5202 - 2.5202)	64.013 - 64.014 (2.5202 - 2.5202)	64.014 - 64.015 (2.5202 - 2.5203)	64.015 - 64.016 (2.5203 - 2.5203)	64.016 - 64.017 (2.5203 - 2.5203)				
A	59.975 - 59.974 (2.3612 - 2.3612)	0	0	0	01	01	01	1	1	1	1	12	12	12	2	2	2	23	23	23	3	3	3	34	34	34			
B	59.974 - 59.973 (2.3612 - 2.3611)	0	0	01	01	01	1	1	1	1	1	12	12	12	2	2	2	23	23	23	3	3	3	34	34	34			
C	59.973 - 59.972 (2.3611 - 2.3611)	0	0	01	01	1	1	1	1	1	1	12	12	12	2	2	2	23	23	23	3	3	3	34	34	34			
D	59.972 - 59.971 (2.3611 - 2.3611)	01	01	01	1	1	1	1	1	1	1	12	12	12	2	2	2	23	23	23	3	3	3	34	34	34			
E	59.971 - 59.970 (2.3611 - 2.3610)	01	01	1	1	1	1	1	1	1	1	12	12	12	2	2	2	23	23	23	3	3	3	34	34	34			
F	59.970 - 59.969 (2.3610 - 2.3610)	01	1	1	1	1	1	1	1	1	1	12	12	12	2	2	2	23	23	23	3	3	3	34	34	34			
G	59.969 - 59.968 (2.3610 - 2.3609)	1	1	1	1	1	1	1	1	1	1	12	12	12	2	2	2	23	23	23	3	3	3	34	34	34			
H	59.968 - 59.967 (2.3609 - 2.3609)	1	1	1	1	1	1	1	1	1	1	12	12	12	2	2	2	23	23	23	3	3	3	34	34	34			
J	59.967 - 59.966 (2.3609 - 2.3609)	1	1	1	1	1	1	1	1	1	1	12	12	12	2	2	2	23	23	23	3	3	3	34	34	34			
K	59.966 - 59.965 (2.3909 - 2.3608)	12	12	12	2	2	2	2	2	2	2	23	23	23	3	3	3	34	34	34	4	4	4	45	45	45			
L	59.965 - 59.964 (2.3608 - 2.3608)	12	12	2	2	2	2	2	2	2	2	23	23	23	3	3	3	34	34	34	4	4	4	45	45	45			
M	59.964 - 59.963 (2.3608 - 2.3607)	12	2	2	2	2	2	2	2	2	2	23	23	23	3	3	3	34	34	34	4	4	4	45	45	45			
N	59.963 - 59.962 (2.3607 - 2.3607)	2	2	2	2	2	2	2	2	2	2	23	23	23	3	3	3	34	34	34	4	4	4	45	45	45			
P	59.962 - 59.961 (2.3607 - 2.3607)	2	2	2	2	2	2	2	2	2	2	23	23	23	3	3	3	34	34	34	4	4	4	45	45	45			
R	59.961 - 59.960 (2.3607 - 2.3606)	2	2	2	2	2	2	2	2	2	2	23	23	23	3	3	3	34	34	34	4	4	4	45	45	45			
S	59.960 - 59.959 (2.3606 - 2.3606)	23	23	23	3	3	3	3	3	3	3	34	34	34	4	4	4	45	45	45	5	5	5	56	56	56			
T	59.959 - 59.958 (2.3606 - 2.3605)	23	23	3	3	3	3	3	3	3	3	34	34	34	4	4	4	45	45	45	5	5	5	56	56	56			
U	59.958 - 59.957 (2.3605 - 2.3605)	23	3	3	3	3	3	3	3	3	3	34	34	34	4	4	4	45	45	45	5	5	5	56	56	56			
V	59.957 - 59.956 (2.3605 - 2.3605)	3	3	3	3	3	3	3	3	3	3	34	34	34	4	4	4	45	45	45	5	5	5	56	56	56			
W	59.956 - 59.955 (2.3605 - 2.3604)	3	3	3	3	3	3	3	3	3	3	34	34	34	4	4	4	45	45	45	5	5	5	56	56	56			
X	59.955 - 59.954 (2.3604 - 2.3604)	3	3	3	3	3	3	3	3	3	3	34	34	34	4	4	4	45	45	45	5	5	5	56	56	56			
Y	59.954 - 59.953 (2.3604 - 2.3603)	34	34	34	4	4	4	4	4	4	4	45	45	45	5	5	5	56	56	56	6	6	6	67	67	67			
4	59.953 - 59.952 (2.3603 - 2.3603)	34	34	4	4	4	4	4	4	4	4	45	45	45	5	5	5	56	56	56	6	6	6	67	67	67			
7	59.952 - 59.951 (2.3603 - 2.3603)	34	4	4	4	4	4	4	4	4	4	45	45	45	5	5	5	56	56	56	6	6	6	67	67	67			

Connecting Rod Bearing (Big End)

1. Install the connecting rod bearing to the connecting rod and cap.
2. Install the connecting rod cap to the connecting rod. Tighten to specification. Refer to [EM-116, "Disassembly and Assembly"](#).
3. Measure the inner diameter (C) of each connecting rod (big end) as shown.

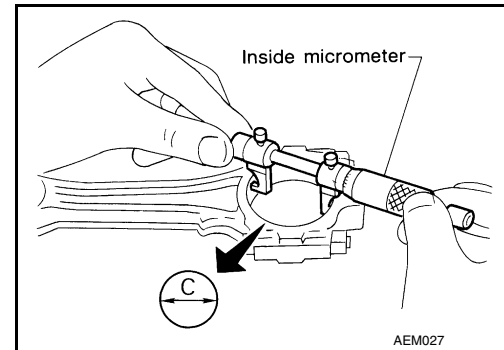

CYLINDER BLOCK

< UNIT DISASSEMBLY AND ASSEMBLY >

4. Measure the outer diameter (Dp) of each crankshaft pin journal.
5. Calculate the connecting rod bearing clearance. Refer to [EM-150. "Connecting Rod Bearing"](#).
Connecting rod bearing clearance = (C) - (Dp)
6. If the calculated clearance exceeds the specified limit, replace the bearings.
7. If the clearance cannot be adjusted within the standard of any bearing, grind the crankshaft journal and use undersized bearings.

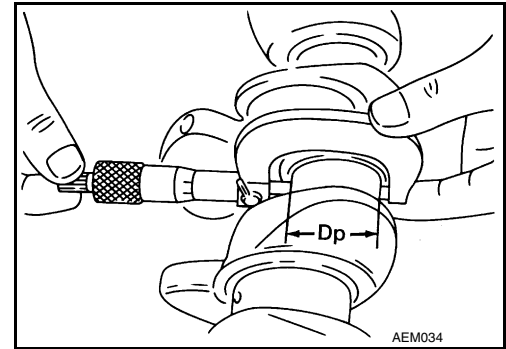

8. If the crankshaft is replaced with a new one, select the connecting rod bearings according to the following table:
Connecting Rod Bearing Grade Number (Identification Color)

Crankshaft pin journal grade number	Connecting rod bearing grade number
0	0 (black)
1	1 (brown)
2	2 (green)

These numbers are punched in either Arabic or Roman numerals.

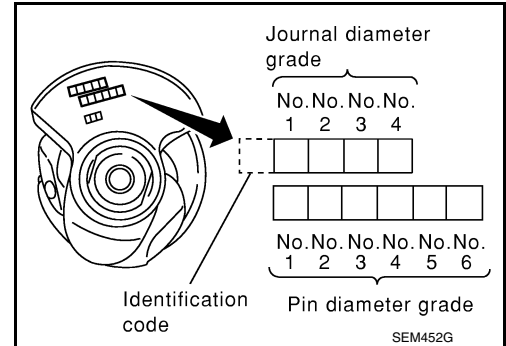

Method B (Using Plastigage)

- Remove oil and dust on the crankshaft pin and the surfaces of each bearing completely.
- Cut a Plastigage slightly shorter than the bearing width, and place it in crankshaft axial direction, avoiding oil holes.
- Install the connecting rod bearings to the connecting rod cap, and tighten the connecting rod nuts to the specified torque.

CAUTION:

Do not rotate the crankshaft.

- Remove the connecting rod cap and bearings, and using the scale on the Plastigage bag, measure the Plastigage width.

NOTE:

The procedure when the measured value exceeds the repair limit is same as that described in "Method A (Using Bore Gauge and Micrometer)".

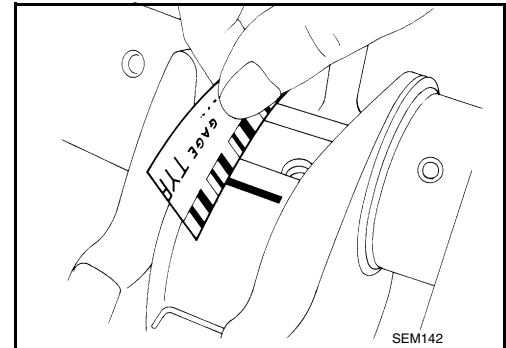

DRIVE PLATE RUNOUT

Use a suitable tool to measure the runout (Total Indicator Reading) as shown. Refer to [EM-151. "Drive Plate"](#).

CAUTION:

- The signal plate is built into the drive assembly. Be careful not to damage the signal plate, particularly the teeth.

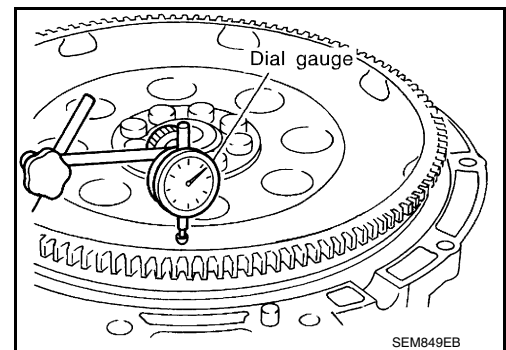

CYLINDER BLOCK

< UNIT DISASSEMBLY AND ASSEMBLY >

- Check the drive plate and signal plate for deformation or cracks.
- Keep all magnetized objects away from the signal plate, particularly the teeth.

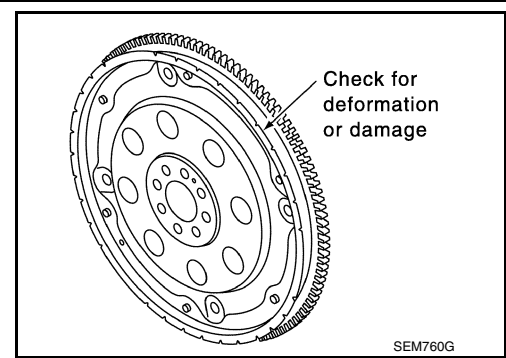

OIL JET

- Check nozzle for deformation and damage.
- Blow compressed air from nozzle, and check for clogs.
- If it is not operating properly, replace oil jet.

OIL JET RELIEF VALVE

- Using a clean plastic stick, press check valve in oil jet relief valve. Make sure that valve moves smoothly with proper reaction force.
- If it is not operating properly, replace oil jet relief valve.

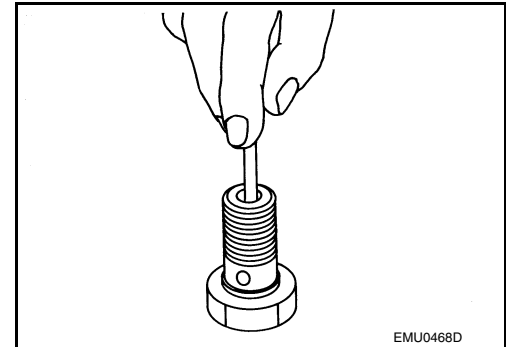

Dowel Pin Alignment

INFOID:0000000011933794

REMOVAL

1. Use suitable tool to lock the drive plate and match mark (A) the drive plate before removing the bolts.

CAUTION:

Do not damage the ring gear teeth, or the signal plate teeth behind the ring gear.

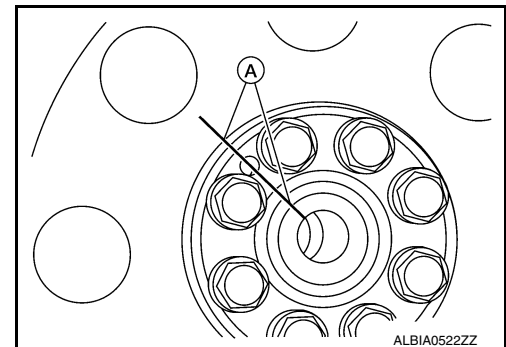

2. Remove drive plate.
 - Loosen the drive plate in a diagonal order.

CAUTION:

- Do not place drive plate with signal plate facing down.
- When handling the signal plate, take care not to damage or scratch it.
- Handle the signal plate in a manner that prevents it from becoming magnetized.

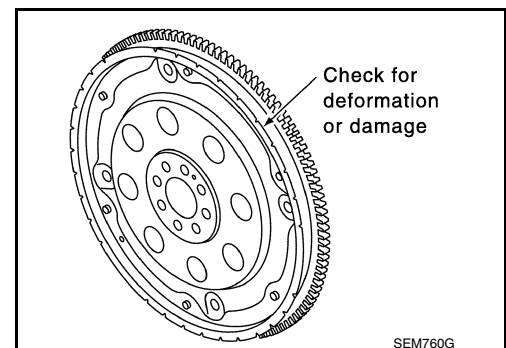

INSTALLATION

Installation is in the reverse order of removal.

A
EM
C
D
E
F
G
H
I
J
K
L
M
N
O
P

CYLINDER BLOCK

< UNIT DISASSEMBLY AND ASSEMBLY >

- When installing the drive plate to the crankshaft, use the match mark (A) as shown to correctly align the crankshaft side dowel pin to the drive plate side dowel pin hole.

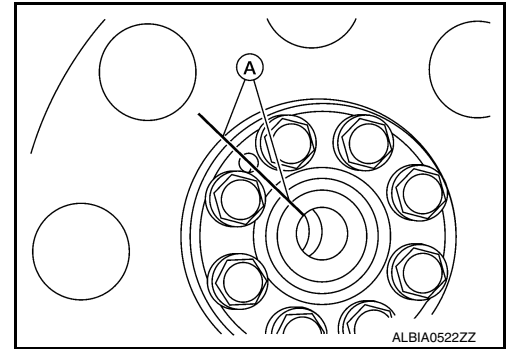

- Install the drive plate and the reinforcement plate in the direction as shown.

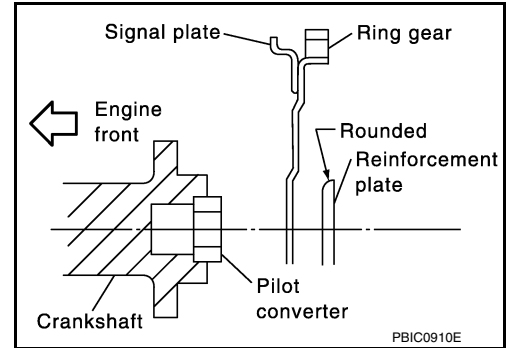

- Tighten the drive plate bolts in a diagonal pattern in two steps. Refer to [EM-116. "Disassembly and Assembly"](#).
- Use a suitable tool to lock the drive plate.

SERVICE DATA AND SPECIFICATIONS (SDS)

< SERVICE DATA AND SPECIFICATIONS (SDS)

SERVICE DATA AND SPECIFICATIONS (SDS)

SERVICE DATA AND SPECIFICATIONS (SDS)

General Specification

INFOID:0000000011933795

A

EM

GENERAL SPECIFICATIONS

Cylinder arrangement	V-6	
Displacement cm ³ (cu in)	3,498 (213.45)	
Bore and stroke mm (in)	95.5 x 81.4 (3.760 x 3.205)	
Valve arrangement	DOHC	
Firing order	1-2-3-4-5-6	
Number of piston rings	Compression	2
	Oil	1
Number of main bearings	4	
Compression ratio	10.6:1	
Compression pressure kPa (kg/cm ² , psi)/300 rpm	Standard	1,275 (13.0, 185)
	Minimum	981 (10.0, 142)
	Differential limit between cylinders	98 (1.0, 14)

C

D

E

F

G

H

I

J

K

L

M

N

O

P

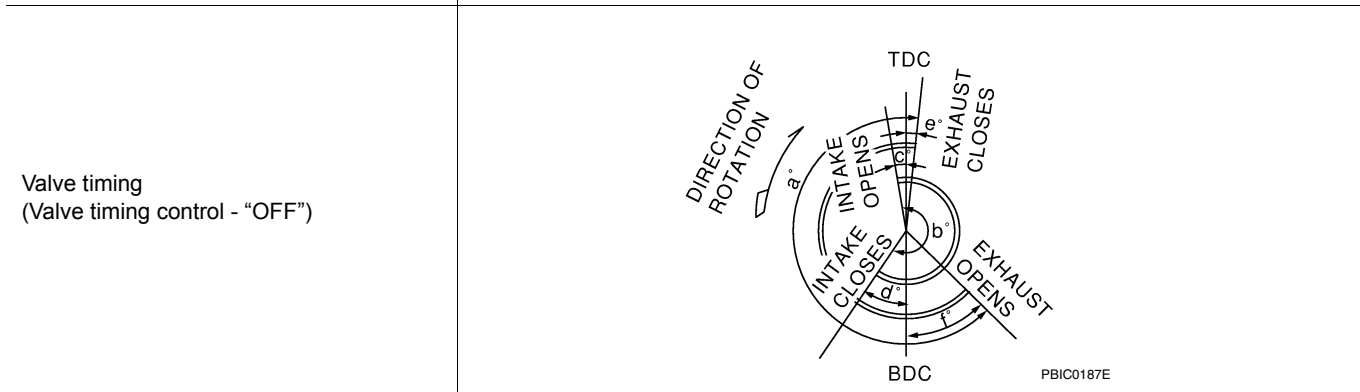
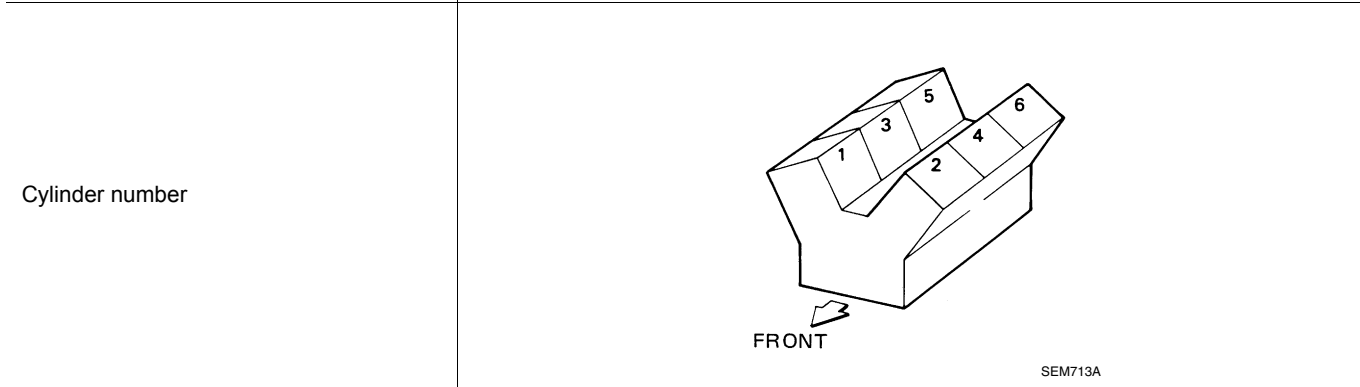

Unit: degree

a	b	c	d	e	f
256	240	-10	70	8	68

Drive Belt

INFOID:0000000011933796

DRIVE BELT

Tension of drive belt	Drive belt tension is not necessary, as it is automatically adjusted by drive belt auto-tensioner.
-----------------------	--

SERVICE DATA AND SPECIFICATIONS (SDS)

< SERVICE DATA AND SPECIFICATIONS (SDS)

Spark Plug

INFOID:000000011933797

SPARK PLUG

Unit: mm (in)

Make	DENSO	
Standard type*	FXE22HR11	
Gap	Standard	1.1 (0.043)
	Limit	1.35 (0.53) (for USA and Canada) 1.25 (0.49) (for Mexico)

*: Always check with the Parts Department for the latest parts information.

Intake Manifold

INFOID:000000011933798

INTAKE MANIFOLD

Unit: mm (in)

Items		Limit
Surface distortion	Intake manifold	0.1 (0.004)

Exhaust Manifold

INFOID:000000011933799

EXHAUST MANIFOLD

Unit: mm (in)

Items		Limit
Surface distortion	Exhaust manifold	0.3 (0.012)

Camshaft

INFOID:000000011933800

CAMSHAFT

Unit: mm (in)

Items		Standard	Limit
Camshaft journal oil clearance	No. 1	0.045 - 0.086 (0.0018 - 0.0034)	0.15 (0.0059)
	No. 2, 3, 4	0.035 - 0.076 (0.0014 - 0.0030)	
Camshaft bracket inner diameter	No. 1	26.000 - 26.021 (1.0236 - 1.0244)	—
	No. 2, 3, 4	23.500 - 23.521 (0.9252 - 0.9260)	—
Camshaft journal diameter	No. 1	25.935 - 25.955 (1.0211 - 1.0218)	—
	No. 2, 3, 4	23.445 - 23.465 (0.9230 - 0.9238)	—
Camshaft end play		0.115 - 0.188 (0.0045 - 0.0074)	0.24 (0.0094)
Camshaft cam height "A"	Intake	45.475 - 45.665 (1.7904 - 1.7978)	0.2 (0.008)* ¹
	Exhaust	45.485 - 45.675 (1.7907 - 1.7982)	0.2 (0.008)* ¹
Camshaft runout [TIR* ²]		Less than 0.02 (0.0008)	0.05 (0.0020)
Camshaft sprocket runout [TIR* ²]		Less than 0.15 (0.0059)	—

SERVICE DATA AND SPECIFICATIONS (SDS)

< SERVICE DATA AND SPECIFICATIONS (SDS)

Difference in level between front end faces of No. 1 camshaft bracket and cylinder head	-0.14 (-0.0055)	—
---	-----------------	---

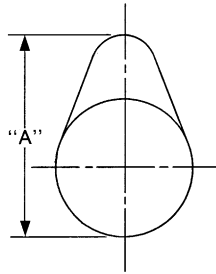

SEM671

*1: Cam wear limit

*2: Total indicator reading

VALVE LIFTER

Unit: mm (in)

Items	Standard
Valve lifter outer diameter	33.977 - 33.987 (1.3377 - 1.3381)
Valve lifter hole diameter	34.000 - 34.016 (1.3386 - 1.3392)
Valve lifter clearance	0.013 - 0.039 (0.0005 - 0.0015)

VALVE CLEARANCE

Unit: mm (in)

Items	Cold	Hot* (reference data)
Intake	0.26 - 0.34 (0.010 - 0.013)	0.304 - 0.416 (0.012 - 0.016)
Exhaust	0.29 - 0.37 (0.011 - 0.015)	0.308 - 0.432 (0.012 - 0.017)

*: Approximately 80°C (176°F)

AVAILABLE VALVE LIFTER

Unit: mm (in)

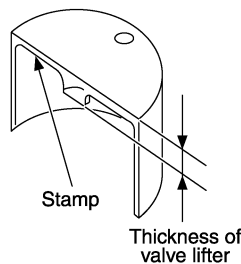

KBIA0119E

Thickness
3.00 (0.1181)
3.02 (0.1189)
3.04 (0.1197)
3.06 (0.1205)
3.08 (0.1213)
3.10 (0.1220)
3.12 (0.1228)

SERVICE DATA AND SPECIFICATIONS (SDS)

< SERVICE DATA AND SPECIFICATIONS (SDS)

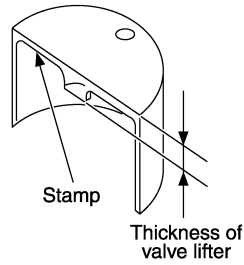

KBIA0119E

Thickness
3.14 (0.1236)
3.16 (0.1244)
3.18 (0.1252)
3.20 (0.1260)
3.22 (0.1268)
3.24 (0.1276)
3.26 (0.1283)
3.28 (0.1291)
3.30 (0.1299)
3.32 (0.1307)
3.34 (0.1315)
3.36 (0.1323)
3.38 (0.1331)
3.40 (0.1339)
3.42 (0.1346)
3.44 (0.1354)
3.46 (0.1362)
3.48 (0.1370)
3.50 (0.1378)

*: Always check with the Parts Department for the latest parts information.

Cylinder Head

INFOID:0000000011933801

CYLINDER HEAD

Unit: mm (in)

Items	Standard	Limit
Head surface distortion	Less than 0.03 (0.0012)	0.1 (0.004)
Normal cylinder head height "H"	126.4 - 126.5 (4.97 - 4.98)	—

SERVICE DATA AND SPECIFICATIONS (SDS)

< SERVICE DATA AND SPECIFICATIONS (SDS)

Items	Standard	Limit
Spark plug tube installation height	37.7 - 39.1 (1.484 - 1.539)	—

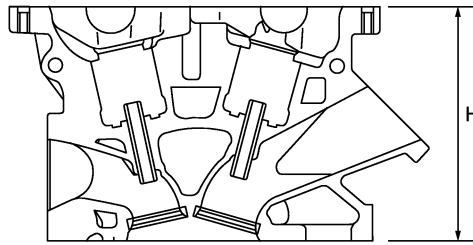

PBIC0924E

VALVE DIMENSIONS

Unit: mm (in)

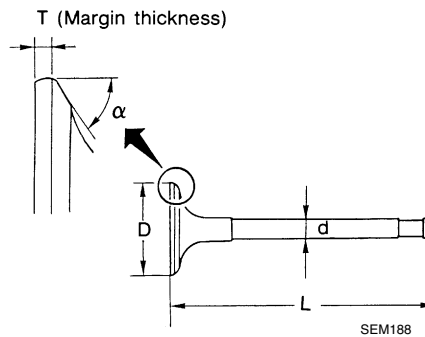

Valve head diameter "D"	Intake	36.6 - 36.9 (1.441 - 1.453)
	Exhaust	30.2 - 30.5 (1.189 - 1.201)
Valve length "L"	Intake	102.02 (4.0165)
	Exhaust	99.56 (3.9191)
Valve stem diameter "d"	Intake	5.965 - 5.980 (0.2348 - 0.2354)
	Exhaust	5.955 - 5.970 (0.2344 - 0.2350)
Valve seat angle "α"	Intake	45°15' - 45°45'
	Exhaust	
Valve margin "T"	Intake	1.15 - 1.45 (0.0453 - 0.0571)
	Exhaust	1.45 - 1.75 (0.0571 - 0.0689)
Valve margin "T" limit		More than 0.5 (0.020)
Valve stem end surface grinding limit		Less than 0.2 (0.008)

VALVE OIL SEAL

Unit: mm (in)

Description	Standard
Valve oil seal installation height	14.3 - 14.9 (0.563 - 0.587)

VALVE GUIDE

SERVICE DATA AND SPECIFICATIONS (SDS)

< SERVICE DATA AND SPECIFICATIONS (SDS)

Unit: mm (in)

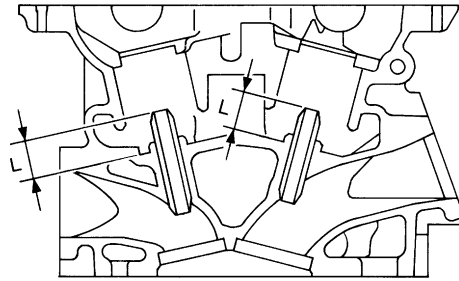

SEM950E

Items		Standard	Oversize (Service) [0.2 (0.008)]
Valve guide	Outer diameter	10.023 - 10.034 (0.3946 - 0.3950)	10.223 - 10.234 (0.4025 - 0.4029)
	Inner diameter (Finished size)	6.000 - 6.018 (0.2362 - 0.2369)	
Cylinder head valve guide hole diameter		9.975 - 9.996 (0.3927 - 0.3935)	10.175 - 10.196 (0.4006 - 0.4014)
Interference fit of valve guide		0.027 - 0.059 (0.0011 - 0.0023)	
Items		Standard	Limit
Valve guide clearance	Intake	0.020 - 0.053 (0.0008 - 0.0021)	0.08 (0.0031)
	Exhaust	0.040 - 0.073 (0.0016 - 0.0029)	0.01 (0.004)
Valve deflection	Intake	—	0.24 (0.0094)
	Exhaust	—	0.28 (0.0110)
Projection length "L"		12.6 - 12.8 (0.496 - 0.504)	

VALVE SEAT

SERVICE DATA AND SPECIFICATIONS (SDS)

< SERVICE DATA AND SPECIFICATIONS (SDS)

Unit: mm (in)

Items	Standard	Oversize (Service) [0.5 (0.02)]
-------	----------	---------------------------------

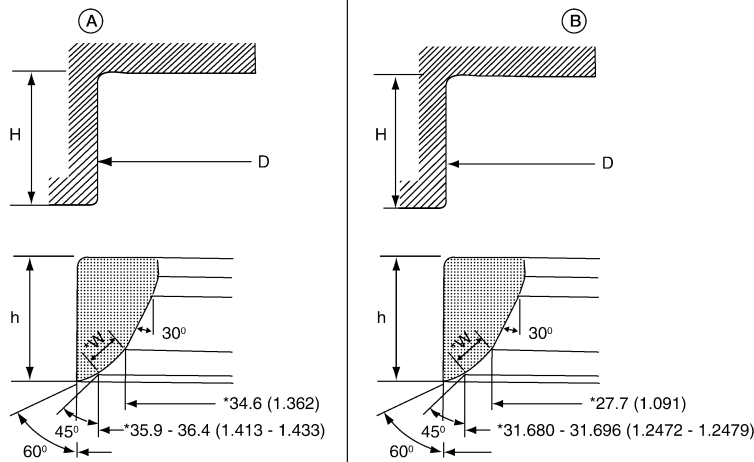

AWBIA0033GB

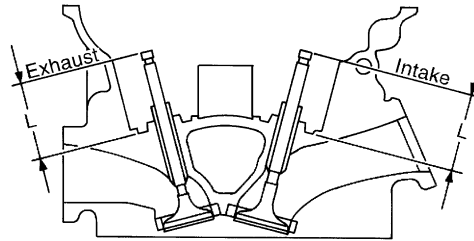

SEM621F

Cylinder head seat recess diameter "D"	Intake (A)	38.000 - 38.016 (1.4961 - 1.4967)	38.500 - 38.516 (1.5157 - 1.5164)
	Exhaust (B)	31.600 - 31.616 (1.2441 - 1.2447)	32.100 - 32.116 (1.2638 - 1.2644)
Valve seat outer diameter	Intake	38.097 - 38.113 (1.4999 - 1.5005)	38.597 - 38.613 (1.5196 - 1.5202)
	Exhaust	31.680 - 31.696 (1.2472 - 1.2479)	32.180 - 32.196 (1.2669 - 1.2676)
Valve seat interference fit	Intake	0.081 - 0.113 (0.0032 - 0.0044)	
	Exhaust	0.064 - 0.096 (0.0025 - 0.0038)	
Height "h"	Intake (A)	5.9 - 6.0 (0.232 - 0.236)	5.0 - 5.1 (0.197 - 0.201)
	Exhaust (B)	5.9 - 6.0 (0.232 - 0.236)	4.9 - 5.0 (0.193 - 0.197)
Contacting width "W"*	Intake (A)	1.18 - 1.22 (0.0465 - 0.0480)	
	Exhaust (B)	1.38 - 1.42 (0.0543 - 0.0559)	
Cylinder head seat recess depth (H)	6.0 (0.236)		
Depth "L"	Intake (A)	41.16 - 41.76 (1.6205 - 1.6441)	
	Exhaust (B)	41.09 - 41.69 (1.6177 - 1.6413)	

*:Machining data

VALVE SPRING

Items	Standard
Free height	47.07 mm (1.8531 in)
Installation height	37.00 mm (1.4567 in)
Installation load	166 - 188 N (16.9 - 19.2 kg, 37 - 42 lb)

SERVICE DATA AND SPECIFICATIONS (SDS)

< SERVICE DATA AND SPECIFICATIONS (SDS)

Items	Standard
Height during valve open	27.20 mm (1.0709 in)
Load with valve open	373 - 421 N (38.0 - 42.9 kg, 84 - 95 lb)
Unit: mm (in)	
Items	Limit
Squareness	2.0 (0.079)

Cylinder Block

INFOID:000000011933802

CYLINDER BLOCK

Unit: mm (in)

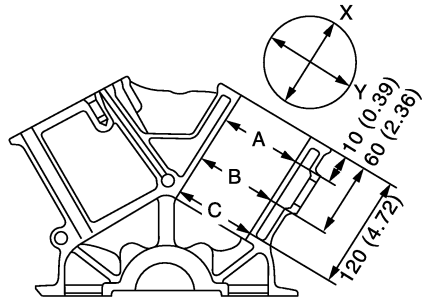

JPBIA2238GB

Surface distortion		Standard		Less than 0.03 (0.0012)
		Limit		0.10 (0.0039)
Main bearing housing inner diameter		Standard		63.993 - 64.017 (2.5194 - 2.5203)
Cylinder bore	Inner diameter	Standard*	Grade No. 1	95.500 - 95.510 (3.7598 - 3.7602)
			Grade No. 2	95.510 - 95.520 (3.7602 - 3.7606)
			Grade No. 3	95.520 - 95.530 (3.7606 - 3.7610)
		Wear limit		0.20 (0.0079)
Out-of-round		Limit		0.015 (0.0006)
Taper (Difference between A and C)				0.015 (0.0006)

SERVICE DATA AND SPECIFICATIONS (SDS)

< SERVICE DATA AND SPECIFICATIONS (SDS)

Main bearing housing inner diameter grade (Without bearing)*	Grade No. A	63.993 - 63.994 (2.5194 - 2.5194)
	Grade No. B	63.994 - 63.995 (2.5194 - 2.5195)
	Grade No. C	63.995 - 63.996 (2.5195 - 2.5195)
	Grade No. D	63.996 - 63.997 (2.5195 - 2.5196)
	Grade No. E	63.997 - 63.998 (2.5196 - 2.5196)
	Grade No. F	63.998 - 63.999 (2.5196 - 2.5196)
	Grade No. G	63.999 - 64.000 (2.5196 - 2.5197)
	Grade No. H	64.000 - 64.001 (2.5197 - 2.5197)
	Grade No. J	64.001 - 64.002 (2.5197 - 2.5198)
	Grade No. K	64.002 - 64.003 (2.5198 - 2.5198)
	Grade No. L	64.003 - 64.004 (2.5198 - 2.5198)
	Grade No. M	64.004 - 64.005 (2.5198 - 2.5199)
	Grade No. N	64.005 - 64.006 (2.5199 - 2.5199)
	Grade No. P	64.006 - 64.007 (2.5199 - 2.5200)
	Grade No. R	64.007 - 64.008 (2.5200 - 2.5200)
	Grade No. S	64.008 - 64.009 (2.5200 - 2.5200)
	Grade No. T	64.009 - 64.010 (2.5200 - 2.5201)
	Grade No. U	64.010 - 64.011 (2.5201 - 2.5201)
	Grade No. V	64.011 - 64.012 (2.5201 - 2.5202)
Grade No. W	64.012 - 64.013 (2.5202 - 2.5202)	
Grade No. X	64.013 - 64.014 (2.5202 - 2.5202)	
Grade No. Y	64.014 - 64.015 (2.5202 - 2.5203)	
Grade No. 4	64.015 - 64.016 (2.5203 - 2.5203)	
Grade No. 7	64.016 - 64.017 (2.5203 - 2.5203)	
Difference in inner diameter between cylinders	Standard	Less than 0.03 (0.0012)

*: Always check with the Parts Department for the latest parts information.

AVAILABLE PISTON

Unit: mm (in)

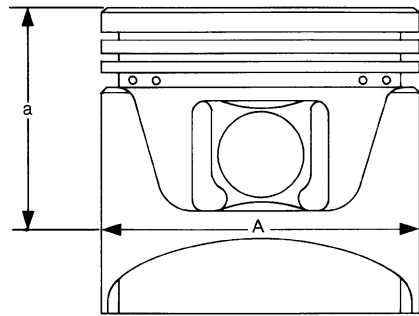

Items	Grade*	Standard
Piston skirt diameter "A"	Grade No. 1	95.480 - 95.490 (3.7590 - 3.7594)
	Grade No. 2	95.490 - 95.500 (3.7594 - 3.7598)
	Grade No. 3	95.500 - 95.510 (3.7598 - 3.7602)
"a" dimension		38.0 (1.496)
Piston pin hole diameter	Grade No. 0	21.993 - 21.999 (0.8659 - 0.8661)
	Grade No. 1	21.999 - 22.005 (0.8661 - 0.8663)
Piston to cylinder bore clearance		0.010 - 0.030 (0.0004 - 0.0012)

*: Always check with the Parts Department for the latest parts information.

PISTON RING

Unit: mm (in)

Items	Standard	Limit
Side clearance	Top	0.045 - 0.080 (0.0018 - 0.0031)
	2nd	0.030 - 0.070 (0.0012 - 0.0028)
	Oil ring	0.065 - 0.125 (0.0018 - 0.0049)
		—

SERVICE DATA AND SPECIFICATIONS (SDS)

< SERVICE DATA AND SPECIFICATIONS (SDS)

End gap	Top	0.23 - 0.28 (0.0091 - 0.0110)	0.50 (0.0197)
	2nd	0.33 - 0.43 (0.0130 - 0.0169)	0.62 (0.0244)
	Oil (rail ring)	0.20 - 0.45 (0.0079 - 0.0177)	0.80 (0.0315)

PISTON PIN

Unit: mm (in)

Items	Grade*	Standard	Limit
Piston pin outer diameter	Grade No. 0	21.989 - 21.995 (0.8657 - 0.8659)	—
	Grade No. 1	21.995 - 22.001 (0.8659 - 0.8662)	—
Piston to piston pin oil clearance		0.002 - 0.010 (0.0001 - 0.0004)	—
Connecting rod bushing oil clearance		0.005 - 0.017 (0.0002 - 0.0007)	0.030 (0.0012)

*: Always check with the Parts Department for the latest parts information.

CONNECTING ROD

Unit: mm (in)

Items	Grade ¹	Standard	Limit
Center distance		144.15 - 144.25 (5.68 - 5.68)	—
Bend [per 100 (3.94)]		—	0.15 (0.0059)
Torsion [per 100 (3.94)]		—	0.30 (0.0118)
Connecting rod small end inner diameter		23.980 - 24.000 (0.9441 - 0.9449)	—
Connecting rod bushing inner diameter ²	Grade No. 0	22.000 - 22.006 (0.8661 - 0.8664)	—
	Grade No. 1	22.006 - 22.012 (0.8664 - 0.8666)	—
Connecting rod big end diameter (Without bearing)		55.000 - 55.013 (2.1654 - 2.1659)	—
Side clearance		0.20 - 0.35 (0.0079 - 0.0138)	0.40 (0.0157)

¹: Always check with the Parts Department for the latest parts information.

²: After installing in connecting rod

CRANKSHAFT

Unit: mm (in)

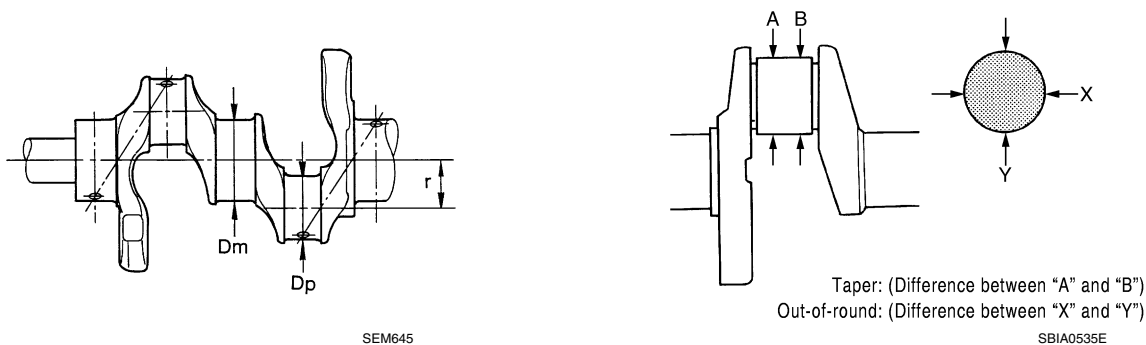

SERVICE DATA AND SPECIFICATIONS (SDS)

< SERVICE DATA AND SPECIFICATIONS (SDS)

		Grade ¹	Dimension
		Main journal diameter. "Dm" grade	Standard
Grade No. B	59.974 - 59.973 (2.3612 - 2.3611)		
Grade No. C	59.973 - 59.972 (2.3611 - 2.3611)		
Grade No. D	59.972 - 59.971 (2.3611 - 2.3611)		
Grade No. E	59.971 - 59.970 (2.3611 - 2.3610)		
Grade No. F	59.970 - 59.969 (2.3610 - 2.3610)		
Grade No. G	59.969 - 59.968 (2.3610 - 2.3609)		
Grade No. H	59.968 - 59.967 (2.3609 - 2.3609)		
Grade No. J	59.967 - 59.966 (2.3609 - 2.3609)		
Grade No. K	59.966 - 59.965 (2.3609 - 2.3608)		
Grade No. L	59.965 - 59.964 (2.3608 - 2.3608)		
Grade No. M	59.964 - 59.963 (2.3608 - 2.3607)		
Grade No. N	59.963 - 59.962 (2.3607 - 2.3607)		
Grade No. P	59.962 - 59.961 (2.3607 - 2.3607)		
Grade No. R	59.961 - 59.960 (2.3607 - 2.3606)		
Grade No. S	59.960 - 59.959 (2.3606 - 2.3606)		
Grade No. T	59.959 - 59.958 (2.3606 - 2.3605)		
Grade No. U	59.958 - 59.957 (2.3605 - 2.3605)		
Grade No. V	59.957 - 59.956 (2.3605 - 2.3605)		
Grade No. W	59.956 - 59.955 (2.3605 - 2.3604)		
Grade No. X	59.955 - 59.954 (2.3604 - 2.3604)		
Grade No. Y	59.954 - 59.953 (2.3604 - 2.3603)		
Grade No. 4	59.953 - 59.952 (2.3603 - 2.3603)		
Grade No. 7	59.952 - 59.951 (2.3603 - 2.3603)		
Pin journal diameter. "Dp" grade	Standard	Grade No. 0	51.968 - 51.974 (2.0460 - 2.0462)
		Grade No. 1	51.962 - 51.968 (2.0457 - 2.0460)
		Grade No. 2	51.956 - 51.962 (2.0445 - 2.0457)
Center distance "r"			40.66 - 40.74 (1.6008 - 1.6039)
Taper (Difference between "A" and "B")	Limit		Less than 0.002 (0.0001)
Out-of-round (Difference between "X" and "Y")			Less than 0.002 (0.0001)
Crankshaft runout [TIR ²]	Standard		Less than 0.05 (0.0020)
	Limit		0.10 (0.0039)
Crankshaft end play	Standard		0.10 - 0.25 (0.0039 - 0.0098)
	Limit		0.30 (0.0118)
Fillet role of crankshaft journal	Standard		More than 0.10 (0.0039)

¹: Always check with the Parts Department for the latest parts information.

²: Total indicator reading

Main Bearing

INFOID:000000011933803

MAIN BEARING

Unit: mm (in)

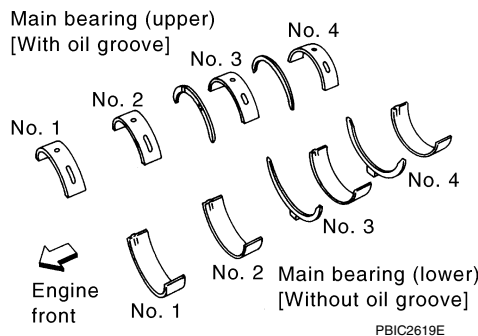

Grade number*	Thickness	Width	Identification color	Remarks
---------------	-----------	-------	----------------------	---------

SERVICE DATA AND SPECIFICATIONS (SDS)

< SERVICE DATA AND SPECIFICATIONS (SDS)

0		2.000 - 2.003 (0.0787 - 0.0789)	19.9 - 20.1 (0.783 - 0.791)	Black	Grade is the same for upper and lower bearings.
1		2.003 - 2.006 (0.0789 - 0.0790)		Brown	
2		2.006 - 2.009 (0.0790 - 0.0791)		Green	
3		2.009 - 2.012 (0.0791 - 0.0792)		Yellow	
4		2.012 - 2.015 (0.0792 - 0.0793)		Blue	
5		2.015 - 2.018 (0.0793 - 0.0794)		Pink	
6		2.018 - 2.021 (0.0794 - 0.0796)		Purple	
7		2.021 - 2.024 (0.0796 - 0.0797)		White	
01	UPR	2.003 - 2.006 (0.0789 - 0.0790)		Brown	Grade and color are different for upper and lower bearings.
	LWR	2.000 - 2.003 (0.0787 - 0.0789)		Black	
12	UPR	2.006 - 2.009 (0.0790 - 0.0791)		Green	
	LWR	2.003 - 2.006 (0.0789 - 0.0790)		Brown	
23	UPR	2.009 - 2.012 (0.0791 - 0.0792)		Yellow	
	LWR	2.006 - 2.009 (0.0790 - 0.0791)		Green	
34	UPR	2.012 - 2.015 (0.0792 - 0.0793)	Blue		
	LWR	2.009 - 2.012 (0.0791 - 0.0792)	Yellow		
45	UPR	2.015 - 2.018 (0.0793 - 0.0794)	Pink		
	LWR	2.012 - 2.015 (0.0792 - 0.0793)	Blue		
56	UPR	2.018 - 2.021 (0.0794 - 0.0796)	Purple		
	LWR	2.015 - 2.018 (0.0793 - 0.0794)	Pink		
67	UPR	2.021 - 2.024 (0.0796 - 0.0797)	White		
	LWR	2.018 - 2.021 (0.0794 - 0.0796)	Purple		

*: Always check with the Parts Department for the latest parts information.

UNDERSIZE

Unit: mm (in)

Items	Thickness	Main journal diameter
0.25 (0.0098)	2.132 - 2.140 (0.0839 - 0.0843)	Grind so that bearing clearance is the specified value.

MAIN BEARING OIL CLEARANCE

Unit: mm (in)

Items	Standard	Limit
Main bearing oil clearance	0.012 - 0.022 (0.0005 - 0.0009)*	0.065 (0.0026)

*: Actual clearance

Connecting Rod Bearing

INFOID:000000011933804

CONNECTING ROD BEARING

Unit: mm (in)

Grade number*	Thickness	Identification color (mark)
0	1.500 - 1.503 (0.0591 - 0.0592)	Black
1	1.503 - 1.506 (0.0592 - 0.0593)	Brown
2	1.506 - 1.509 (0.0593 - 0.0594)	Green

*: Always check with the Parts Department for the latest parts information.

UNDERSIZE

Unit: mm (in)

Items	Thickness	Crank pin journal diameter "Dp"
0.25 (0.0098)	1.626 - 1.634 (0.0640 - 0.0643)	Grind so that bearing clearance is the specified value.

SERVICE DATA AND SPECIFICATIONS (SDS)

< SERVICE DATA AND SPECIFICATIONS (SDS)

CONNECTING ROD BEARING OIL CLEARANCE

Unit: mm (in)

Items	Standard	Limit
Connecting rod bearing oil clearance	0.020 - 0.045 (0.0008 - 0.0018)*	0.070 (0.0028)

*: Actual clearance

Drive Plate

INFOID:0000000011933805

Unit: mm (in)

Drive plate runout [TIR]* - on torque converter mounting surface	Less than 0.35 (0.0138)
Drive plate runout [TIR]* - on ring gear	0.5 (0.0197)

*: Total indicator reading

A
EM
C
D
E
F
G
H
I
J
K
L
M
N
O
P