

SECTION **FL**
FUEL SYSTEM

CONTENTS

PREPARATION	2	FUEL TANK	9	
Special Service Tools	2	Removal and Installation	9	
Commercial Service Tools	2	REMOVAL	9	
FUEL SYSTEM	3	INSTALLATION	10	
Checking Fuel Lines	3	INSPECTION AFTER INSTALLATION	11	
General Precautions	3	SERVICE DATA AND SPECIFICATIONS (SDS)	12	
FUEL LEVEL SENSOR UNIT, FUEL FILTER AND		Standard and Limit	12	
FUEL PUMP ASSEMBLY	4	FUEL TANK	12	
Removal and Installation	4			
REMOVAL	4			
INSTALLATION	7			
INSPECTION AFTER INSTALLATION	8			

PREPARATION

PREPARATION

PFP:00002

Special Service Tools

NBS002RM

The actual shapes of Kent-Moore tools may differ from those of special service tools illustrated here.

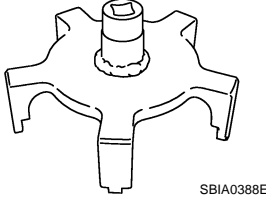
(Kent-Moore No.) Tool name	Description
(J-46211) Fuel tank lock ring wrench 	Removing and installing fuel tank retainer

Commercial Service Tools

NBS002RM

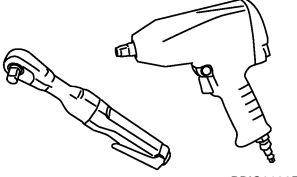
Tool name	Description
Power tool 	Loosening nuts and bolts

FUEL SYSTEM

PFP:17503

Checking Fuel Lines

NBS002RO

Inspect fuel lines, fuel filler cap and fuel tank for improper attachment, leaks, cracks, damage, loose connections, chafing or deterioration.

If necessary, repair or replace damaged parts.

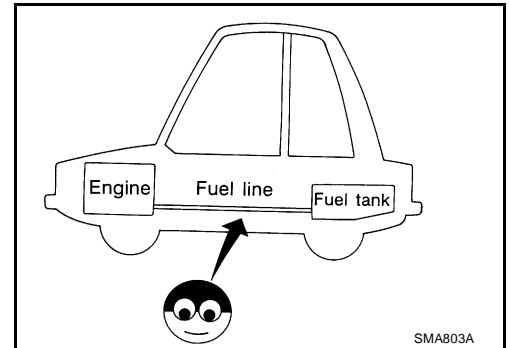

NBS002RP

General Precautions

WARNING:

When replacing fuel line parts, be sure to observe the following.

- Put a "CAUTION: FLAMMABLE" sign in the workshop.
- Be sure to work in a well ventilated area and furnish workshop with a CO₂ fire extinguisher.
- Do not smoke while servicing fuel system. Keep open flames and sparks away from the work area.
- Put drained fuel in an explosion-proof container and put the lid on securely. Keep the container in safe area.

CAUTION:

- Use gasoline required by the regulations for octane number. Refer to [GI-6. "Precautions for Fuel \(Unleaded Premium Gasoline Recommended\)"](#).
- Before removing fuel line parts, carry out the following procedures:
 - Release fuel pressure from the fuel lines. Refer to [EC-78. "FUEL PRESSURE RELEASE"](#).
 - Disconnect negative battery terminal.
- Always replace O-rings and clamps with new ones.
- Do not kink or twist tubes when they are being installed.
- After connecting fuel tube quick connectors, make sure quick connectors are secure. Ensure that connector and resin tube do not contact any adjacent parts.
- After installing tubes, make sure there is no fuel leakage at connections in the following steps.
 - Apply fuel pressure to fuel lines with turning ignition switch "ON" (with engine stopped). Then check for fuel leaks at connections.
 - Start engine and rev it up and check for fuel leaks at connections.
- Use only a genuine NISSAN fuel filler cap as a replacement. If an incorrect fuel filler cap is used, the "MIL" may come on.
- For servicing "Evaporative Emission System" parts, refer to [EC-30. "EVAPORATIVE EMISSION SYSTEM"](#).
- For servicing "On Board Refueling Vapor Recovery (ORVR)" parts, refer to [EC-37. "ON BOARD REFUELING VAPOR RECOVERY \(ORVR\)"](#).

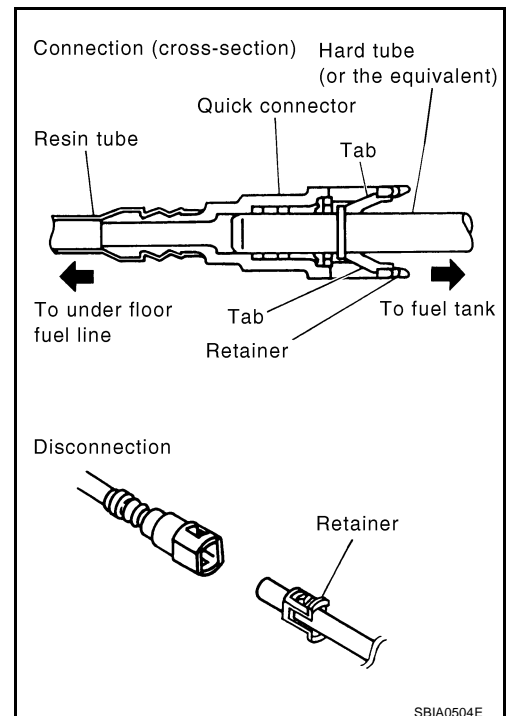

FUEL LEVEL SENSOR UNIT, FUEL FILTER AND FUEL PUMP ASSEMBLY

FUEL LEVEL SENSOR UNIT, FUEL FILTER AND FUEL PUMP ASSEMBLY PFP:17042

Removal and Installation

NBS002R0

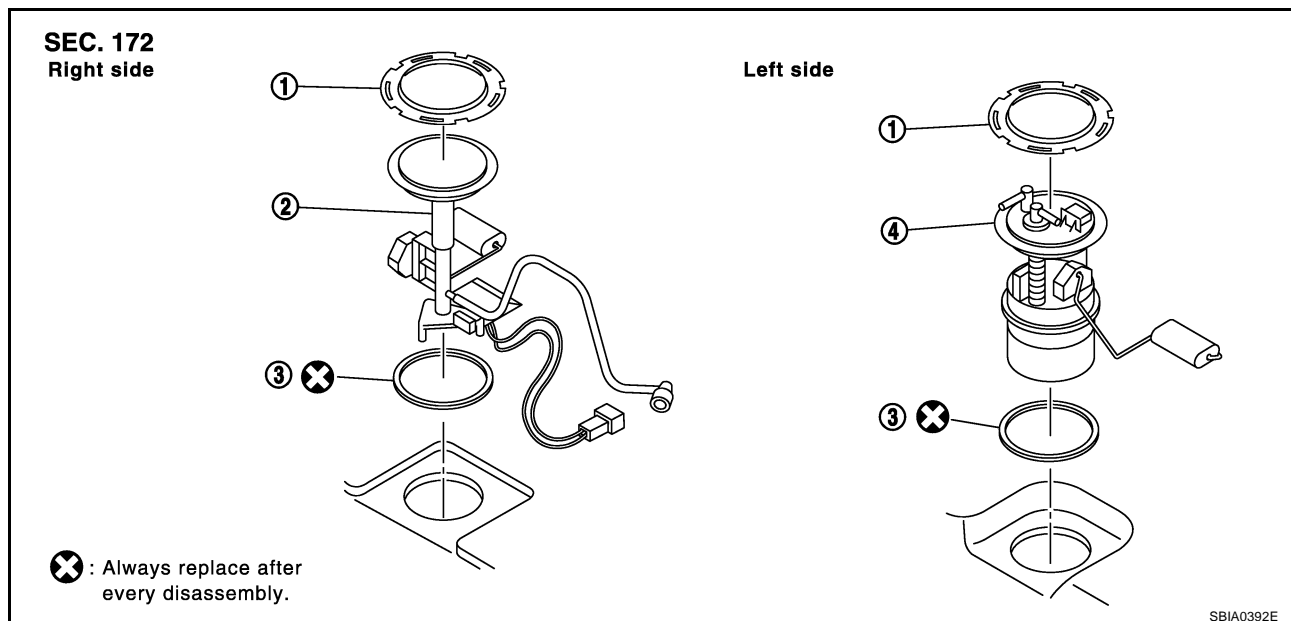

1. Retainer
2. Sub fuel level sensor unit
3. O-ring
4. Main fuel level sensor unit, fuel filter and fuel pump assembly

REMOVAL

WARNING:

Read "General Precautions" before working on the fuel system. Refer to [FL-3, "General Precautions"](#).

1. Check fuel level on fuel gauge. If fuel gauge indicates more than the level as shown in the figure (full or almost full), drain fuel from fuel tank until fuel gauge indicates level as shown in the figure or below.

NOTE:

Because fuel will be spilled when removing fuel level sensor unit for the top of fuel is above the fuel level sensor unit installation surface.

- As a guide, fuel level becomes the position as shown in the figure or below when approximately 20 ℓ (5-1/4 US gal, 4-3/8 Imp gal) of fuel are drained from fuel tank.
 - In a case that fuel pump does not operate, perform the following procedure.
- a. Insert hose of less than 25 mm (0.98 in) in diameter into fuel filler tube through fuel filler opening to draw fuel from fuel filler tube.
 - b. Disconnect fuel filler hose from fuel filler tube. Refer to [FL-9, "FUEL TANK"](#).
 - c. Insert hose into fuel tank through fuel filler hose to draw fuel from fuel tank.
2. Release the fuel pressure from the fuel lines. Refer to [EC-78, "FUEL PRESSURE RELEASE"](#).
 3. Open fuel filler lid.
 4. Open fuel filler cap and release the pressure inside fuel tank.
 5. Remove rear seat cushion trim and pad bolts, then lift up rear seat cushion. Refer to [SE-107, "REAR SEAT"](#).

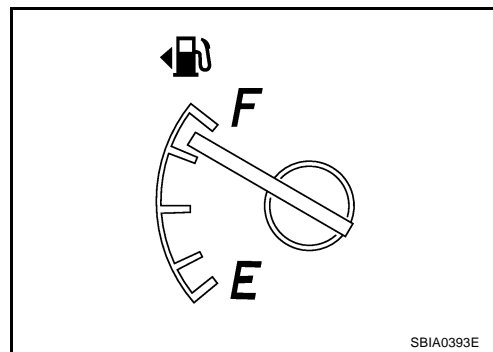

FUEL LEVEL SENSOR UNIT, FUEL FILTER AND FUEL PUMP ASSEMBLY

6. Remove inspection hole cover for main and sub fuel level sensor unit by turning clips counterclockwise by 90 degrees and by mating both cover hole and clip shape.

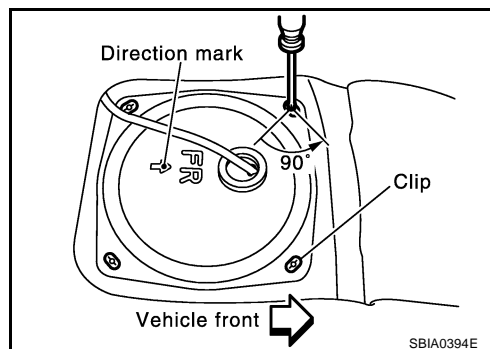

7. Disconnect harness connector and quick connectors for EVAP hose and fuel feed tube

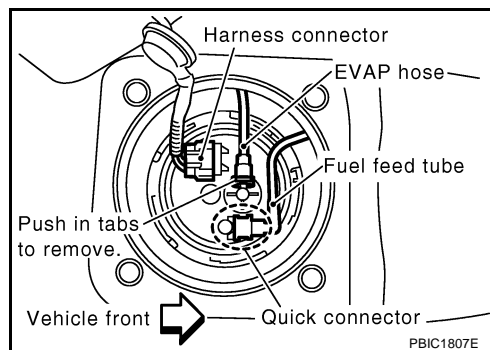

Disconnect quick connector as follows:

- Hold the sides of quick connector, push in tabs and pull out fuel feed tube.
- If quick connector sticks to tube of fuel level sensor unit, push and pull quick connector several times until it start to move. Then disconnect quick connector by pulling.

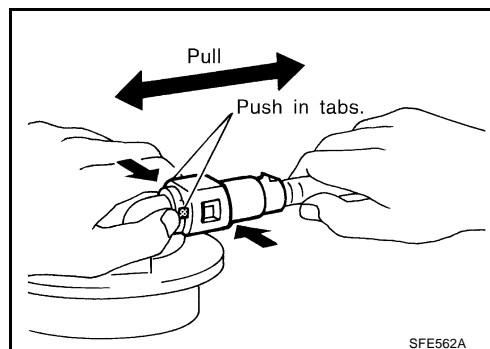

FUEL LEVEL SENSOR UNIT, FUEL FILTER AND FUEL PUMP ASSEMBLY

CAUTION:

- Quick connector can be disconnected when the tabs are completely depressed. Do not twist it more than necessary.
- Do not use any tools to disconnected quick connector.
- Keep resin tube away from heat. Be especially careful when welding near the resin tube.
- Prevent acid liquid such as battery electrolyte, etc. from getting on resin tube.
- Do not bend or twist resin tube during installation and disconnection.
- Do not remove the remaining retainer on hard tube (or the equivalent) except when resin tube or retainer is replaced.
- When resin tube or hard tube (or the equivalent) is replaced, also replace retainer with new one.
- Replace same color retainer as before replacing.

Retainer color: Green

- To keep the connecting portion clean and to avoid damage and foreign materials, cover them completely with plastic bags or something similar.

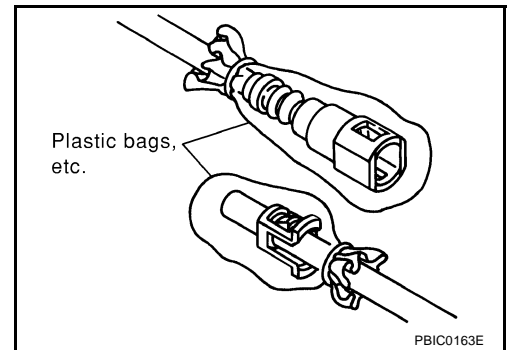
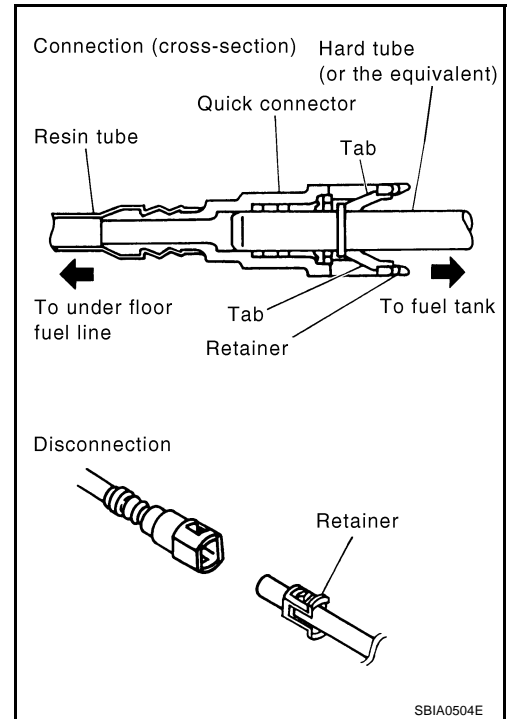

8. Remove retainer for main and sub fuel level sensor unit with fuel tank lock ring wrench (SST) by turning counterclockwise.

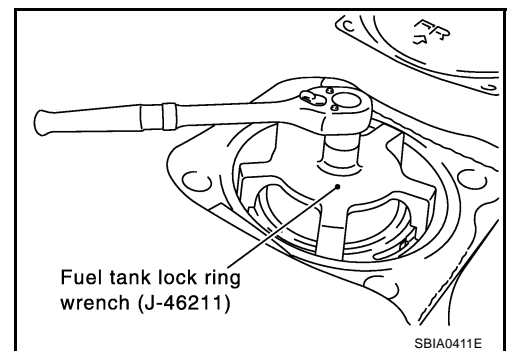

9. Remove main fuel level sensor unit, fuel filter and fuel pump assembly, and sub fuel level sensor unit.
 - Raise main fuel level sensor unit, fuel filter and fuel pump assembly, and disconnect fuel hose connector (push in tabs and pull out) and sub fuel level sensor unit harness connector.
 - Raise and release sub fuel level sensor unit to remove.

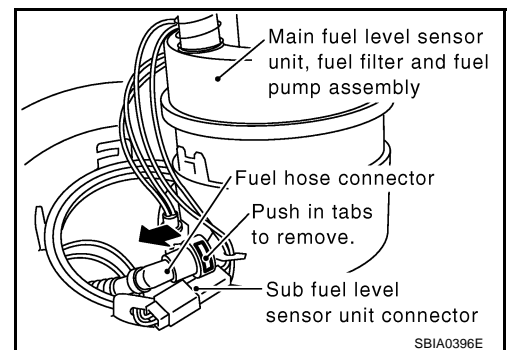

FUEL LEVEL SENSOR UNIT, FUEL FILTER AND FUEL PUMP ASSEMBLY

INSTALLATION

Note the following, and install in the reverse order of removal.

Main and Sub Fuel Level Sensor Unit

1. Install new O-rings to fuel tank without any twist.
2. Connect fuel hose connector (push in until it stops) and sub fuel level sensor unit harness connector.

NOTE:

When installing fuel hose connector insert them fully until a click sound of full stopper engagement is heard.

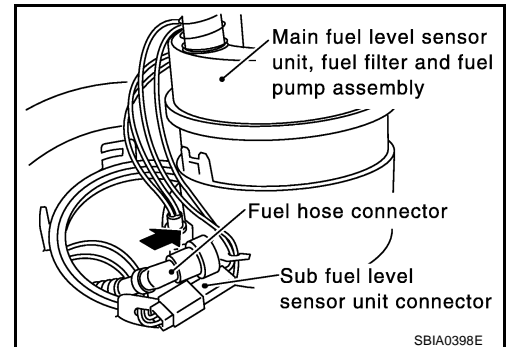

3. Align the direction mark on main and sub fuel level sensor unit with that on fuel tank as shown in the figure, and install them to fuel tank.

CAUTION:

- Do not allow O-ring to drop.
- Do not bend float arm during installing.

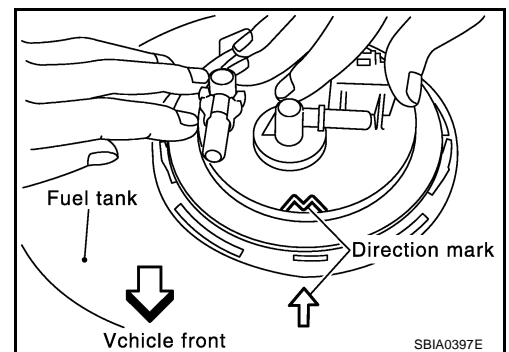

4. Install retainer for main and sub fuel level sensor unit with fuel tank lock ring wrench (SST) by turning clockwise.

CAUTION:

Install retainer horizontally.

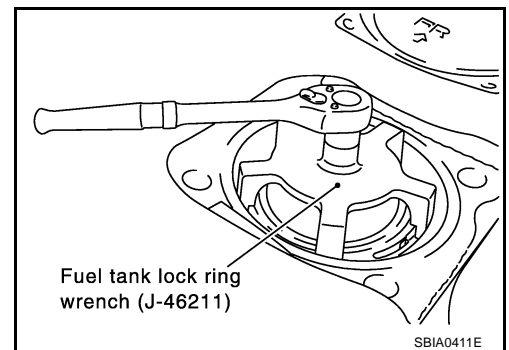

Quick Connector

Connect quick connector as follows:

1. Check the connection for damage or any foreign materials.
2. Align the connector with the tube, then insert the connector straight into the tube until a click sound is heard.
3. After connecting, make sure that the connection is secure by following method.
 - Visually confirm that the two tabs are connected to the connector.

FUEL LEVEL SENSOR UNIT, FUEL FILTER AND FUEL PUMP ASSEMBLY

- Pull the tube and the connector to make sure they are securely connected.

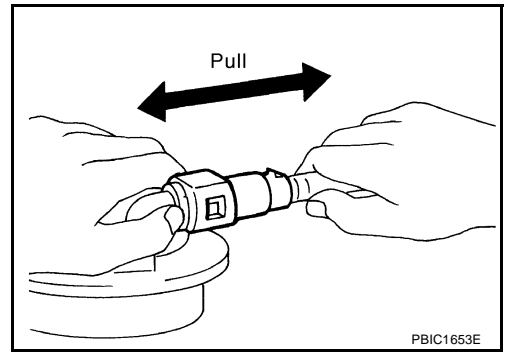

Inspection Hole Cover

1. Install inspection hole cover with front mark (arrow) facing front of vehicle (Both RH and LH).
2. Lock clips by turning clockwise.

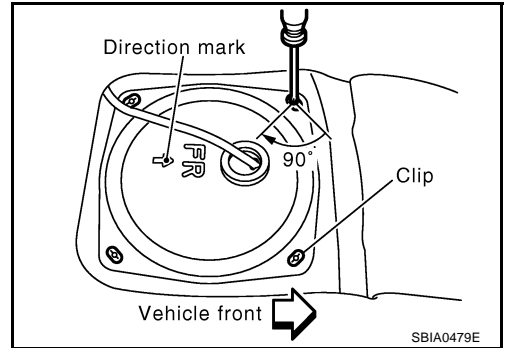

INSPECTION AFTER INSTALLATION

Use the following procedure to check for fuel leaks.

1. Turn ignition switch "ON" (with engine stopped), then check connections for leaks by applying fuel pressure to fuel piping.
2. Start engine and rev it up and make sure there are no fuel leaks at the fuel system connections.

FUEL TANK

PF17202

NBS002RR

FUEL TANK

Removal and Installation

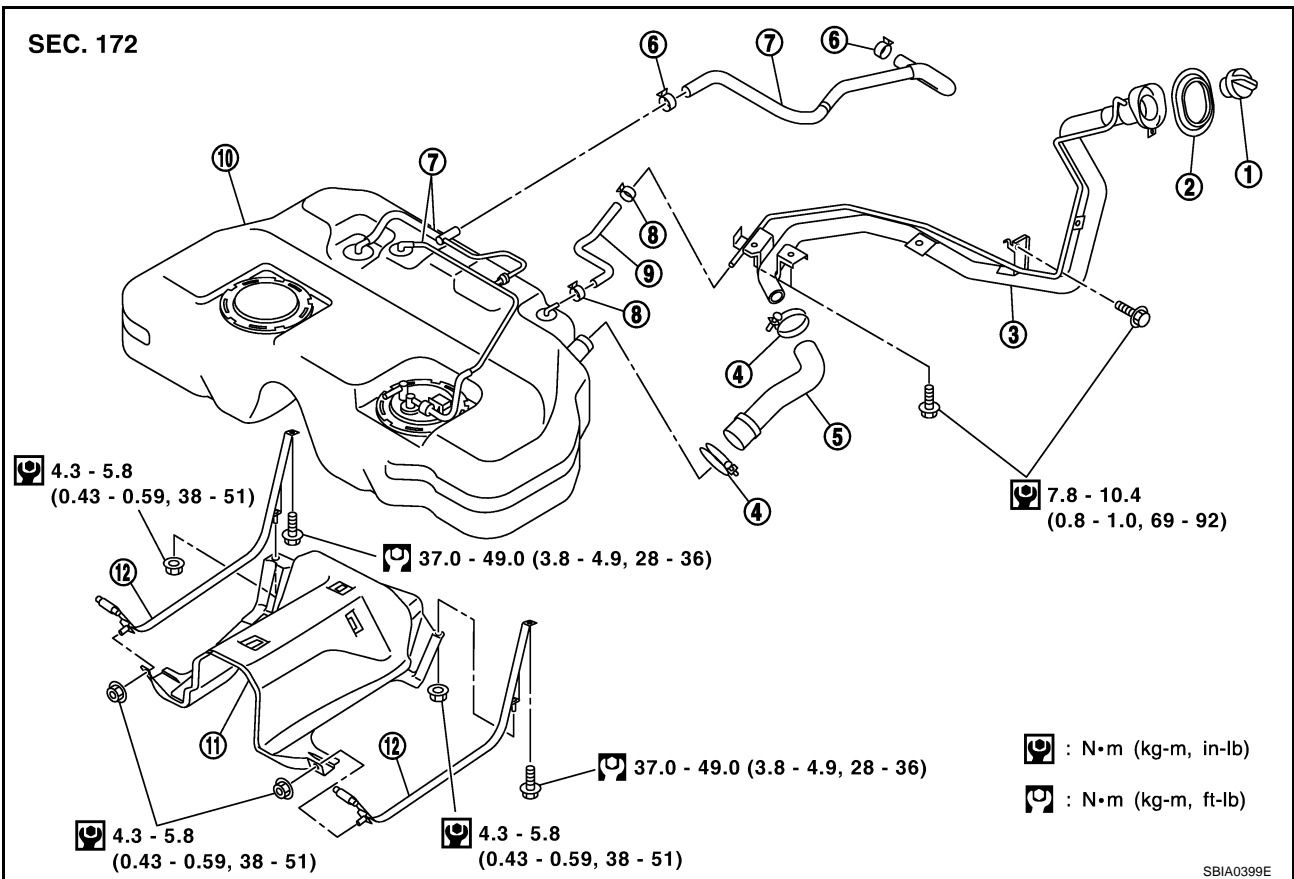

- | | | |
|------------------------|-------------------------|------------------------------|
| 1. Fuel filler cap | 2. Grommet | 3. Fuel filler tube |
| 4. Hose clamp | 5. Fuel filler hose | 6. Hose clamp |
| 7. EVAP/Vent line hose | 8. Hose clamp | 9. EVAP (Recirculation) hose |
| 10. Fuel tank | 11. Fuel tank protector | 12. Fuel tank mounting band |

REMOVAL

WARNING:

Be sure to read "General Precautions" when working on fuel system. Refer to [FL-3, "General Precautions"](#).

- Drain fuel from fuel tank if necessary. Refer to [FL-4, "REMOVAL"](#).

CAUTION:

For the safety work and to maintain fuel tank gravity at center, drain fuel to the level where fuel tank weight at left and right becomes equal.

- Perform work on level place.
 1. Perform steps 2 to 7 of "REMOVAL" in "FUEL LEVEL SENSOR UNIT, FUEL FILTER AND FUEL PUMP ASSEMBLY". Refer to [FL-4, "REMOVAL"](#).
 2. Remove center muffler. Refer to [EX-3, "EXHAUST SYSTEM"](#).
 3. Remove rear propeller shaft (AWD models). Refer to [PR-4, "REAR PROPELLER SHAFT"](#).
 4. Remove parking brake cables. Refer to [PB-4, "PARKING BRAKE CONTROL"](#).
 5. Remove rear final drive assembly (AWD models).
 - Using a transmission jack, support the bottom of the rear final drive assembly. Refer to [RFD-14, "REAR FINAL DRIVE ASSEMBLY"](#).
 6. Remove mounting nuts on the rear suspension member, and lower the transmission jack carefully until just before rear suspension member is removed from stud bolts on the vehicle (AWD models). Refer to [RSU-5, "REAR SUSPENSION ASSEMBLY"](#).
 7. Remove fuel tank protector.

FUEL TANK

8. Disconnect fuel filler hose, EVAP/Vent line hose and EVAP (Recirculation) hose at the other end than fuel tank side.

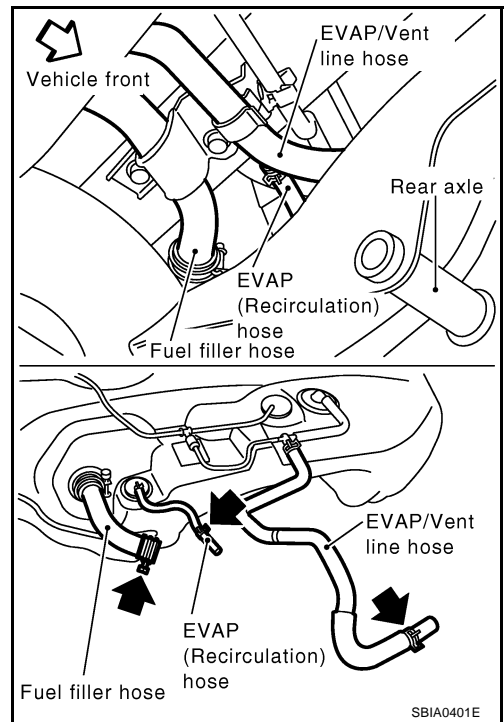

9. Support the lower part of fuel tank with transmission jack.

CAUTION:

Support the position that fuel tank mounting bands do not engage.

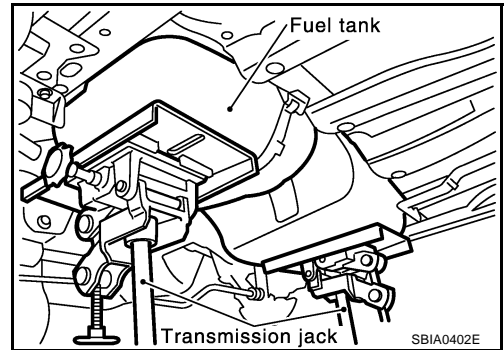

10. Remove fuel tank mounting bands.
11. Supporting with hands, descend transmission jack carefully, and remove fuel tank.

CAUTION:

- **Make sure that all connection points have been disconnected.**
- **Confirm there is no interference with vehicle.**

12. Remove fuel filler tube, if necessary.

INSTALLATION

Note the following, and install in the reverse order of removal.

- Surely clamp fuel hoses and insert hose to the length below.

Fuel filler hose : 35 mm (1.38 in)

The other hoses : 25 mm (0.98 in)

- Be sure hose clamp is not placed on swelled area of fuel tube.
- Tighten fuel hose clamp so that the distance between its lugs becomes to the following.

Fuel tank side : 2 - 6 mm (0.08 - 0.24 in)

Fuel filler tube side : 5 - 9 mm (0.20 - 0.35 in)

- Push the fuel tank mounting band pin to the vehicle side securely.
- Before fixing the fuel tank, temporarily install the filler tube.

FUEL TANK

CAUTION:

Use genuine fuel filler tube mounting bolts or equivalent. Make sure to tighten them to the specified torque.

- To connect the quick connector, refer to [FL-7, "Quick Connector"](#).

INSPECTION AFTER INSTALLATION

Make sure there is no fuel leakage at connections in the following steps.

1. Turn ignition switch "ON" (with engine stopped), and check connections for leakage by applying fuel pressure to fuel piping.
 2. Start engine and rev it up and make sure there are no fuel leaks at the fuel system tube and hose connections.
- After removing/installing rear suspension assembly, make sure to adjust wheel alignment and then, adjust neutral position of steering angle sensor. Refer to [RSU-5, "Wheel Alignment Inspection"](#) and [BRC-46, "Adjustment of Steering Angle Sensor Neutral Position"](#).

A

FL

C

D

E

F

G

H

I

J

K

L

M

SERVICE DATA AND SPECIFICATIONS (SDS)

SERVICE DATA AND SPECIFICATIONS (SDS)

PFP:00030

Standard and Limit FUEL TANK

NBS002RS

Fuel tank capacity	Approx. 82 ℓ (21-5/8 US gal, 18 Imp gal)
Fuel recommendation	Refer to GI-6