

SECTION **ADP**

AUTOMATIC DRIVE POSITIONER

A
B
C
D
E
F
G
H
I
ADP
K
L
M
N
O
P

CONTENTS

<p>BASIC INSPECTION 5</p> <p>DIAGNOSIS AND REPAIR WORK FLOW 5</p> <p style="padding-left: 20px;">Work Flow5</p> <p>INSPECTION AND ADJUSTMENT 8</p> <p>ADDITIONAL SERVICE WHEN REMOVING BATTERY NEGATIVE TERMINAL8</p> <p style="padding-left: 20px;">ADDITIONAL SERVICE WHEN REMOVING BATTERY NEGATIVE TERMINAL : Description8</p> <p style="padding-left: 20px;">ADDITIONAL SERVICE WHEN REMOVING BATTERY NEGATIVE TERMINAL : Special Repair Requirement8</p> <p>ADDITIONAL SERVICE WHEN REPLACING CONTROL UNIT8</p> <p style="padding-left: 20px;">ADDITIONAL SERVICE WHEN REPLACING CONTROL UNIT : Description8</p> <p style="padding-left: 20px;">ADDITIONAL SERVICE WHEN REPLACING CONTROL UNIT : Special Repair Requirement8</p> <p>SYSTEM INITIALIZATION9</p> <p style="padding-left: 20px;">SYSTEM INITIALIZATION : Description9</p> <p style="padding-left: 20px;">SYSTEM INITIALIZATION : Special Repair Requirement9</p> <p>MEMORY STORING9</p> <p style="padding-left: 20px;">MEMORY STORING : Description9</p> <p style="padding-left: 20px;">MEMORY STORING : Special Repair Requirement 10</p> <p>SYSTEM SETTING 10</p> <p style="padding-left: 20px;">SYSTEM SETTING : Description 11</p> <p style="padding-left: 20px;">SYSTEM SETTING : Special Repair Requirement 11</p> <p>SYSTEM DESCRIPTION12</p> <p>AUTOMATIC DRIVE POSITIONER SYSTEM....12</p> <p>AUTOMATIC DRIVE POSITIONER SYSTEM 12</p>	<p>AUTOMATIC DRIVE POSITIONER SYSTEM :</p> <p style="padding-left: 20px;">System Diagram12</p> <p>AUTOMATIC DRIVE POSITIONER SYSTEM :</p> <p style="padding-left: 20px;">System Description13</p> <p>AUTOMATIC DRIVE POSITIONER SYSTEM :</p> <p style="padding-left: 20px;">Component Parts Location14</p> <p>AUTOMATIC DRIVE POSITIONER SYSTEM :</p> <p style="padding-left: 20px;">Component Description15</p> <p>MANUAL FUNCTION16</p> <p style="padding-left: 20px;">MANUAL FUNCTION : System Diagram17</p> <p style="padding-left: 20px;">MANUAL FUNCTION : System Description17</p> <p style="padding-left: 20px;">MANUAL FUNCTION : Component Parts Location19</p> <p style="padding-left: 20px;">MANUAL FUNCTION : Component Description20</p> <p>MEMORY FUNCTION21</p> <p style="padding-left: 20px;">MEMORY FUNCTION : System Diagram22</p> <p style="padding-left: 20px;">MEMORY FUNCTION : System Description22</p> <p style="padding-left: 20px;">MEMORY FUNCTION : Component Parts Location24</p> <p style="padding-left: 20px;">MEMORY FUNCTION : Component Description....25</p> <p>EXIT ASSIST FUNCTION26</p> <p style="padding-left: 20px;">EXIT ASSIST FUNCTION : System Diagram27</p> <p style="padding-left: 20px;">EXIT ASSIST FUNCTION : System Description27</p> <p style="padding-left: 20px;">EXIT ASSIST FUNCTION : Component Parts Location29</p> <p style="padding-left: 20px;">EXIT ASSIST FUNCTION :</p> <p style="padding-left: 40px;">Component Description30</p> <p>ENTRY ASSIST FUNCTION31</p> <p style="padding-left: 20px;">ENTRY ASSIST FUNCTION : System Diagram32</p> <p style="padding-left: 20px;">ENTRY ASSIST FUNCTION : System Description32</p> <p style="padding-left: 20px;">ENTRY ASSIST FUNCTION : Component Parts Location34</p> <p style="padding-left: 20px;">ENTRY ASSIST FUNCTION :</p> <p style="padding-left: 40px;">Component Description35</p> <p>INTELLIGENT KEY INTERLOCK FUNCTION36</p>
---	---

INTELLIGENT KEY INTERLOCK FUNCTION : System Diagram	37	AUTOMATIC DRIVE POSITIONER CONTROL UNIT : Diagnosis Procedure	55
INTELLIGENT KEY INTERLOCK FUNCTION : System Description	37	AUTOMATIC DRIVE POSITIONER CONTROL UNIT : Special Repair Requirement	56
INTELLIGENT KEY INTERLOCK FUNCTION : Component Parts Location	39	SLIDING SWITCH	57
INTELLIGENT KEY INTERLOCK FUNCTION : Component Description	40	Description	57
DIAGNOSIS SYSTEM (DRIVER SEAT CONTROL UNIT)	41	Component Function Check	57
Diagnosis Description	41	Diagnosis Procedure	57
CONSULT-III Function	41	Component Inspection	58
DTC/CIRCUIT DIAGNOSIS	44	RECLINING SWITCH	59
U1000 CAN COMM CIRCUIT	44	Description	59
Description	44	Component Function Check	59
DTC Logic	44	Diagnosis Procedure	59
Diagnosis Procedure	44	Component Inspection	60
Special Repair Requirement	44	LIFTING SWITCH (FRONT)	61
U1010 CONTROL UNIT (CAN)	45	Description	61
Description	45	Component Function Check	61
DTC Logic	45	Diagnosis Procedure	61
Diagnosis Procedure	45	Component Inspection	62
B2130 EEPROM	46	LIFTING SWITCH (REAR)	63
DTC Logic	46	Description	63
Diagnosis Procedure	46	Component Function Check	63
B2112 SLIDING MOTOR	47	Diagnosis Procedure	63
Description	47	Component Inspection	64
DTC Logic	47	TILT SWITCH	65
Diagnosis Procedure	47	Description	65
B2113 RECLINING MOTOR	49	Component Function Check	65
Description	49	Diagnosis Procedure	65
DTC Logic	49	Component Inspection	66
Diagnosis Procedure	49	TELESCOPIC SWITCH	67
B2116 TILT MOTOR	51	Description	67
Description	51	Component Function Check	67
DTC Logic	51	Diagnosis Procedure	67
Diagnosis Procedure	51	Component Inspection	68
B2128 UART COMMUNICATION LINE	53	SEAT MEMORY SWITCH	69
Description	53	Description	69
DTC Logic	53	Component Function Check	69
Diagnosis Procedure	53	Diagnosis Procedure	69
POWER SUPPLY AND GROUND CIRCUIT	55	Component Inspection	70
DRIVER SEAT CONTROL UNIT	55	DOOR MIRROR REMOTE CONTROL SWITCH	72
DRIVER SEAT CONTROL UNIT : Diagnosis Procedure	55	CHANGEOVER SWITCH	72
DRIVER SEAT CONTROL UNIT : Special Repair Requirement	55	CHANGEOVER SWITCH : Description	72
AUTOMATIC DRIVE POSITIONER CONTROL UNIT	55	CHANGEOVER SWITCH : Component Function Check	72
		CHANGEOVER SWITCH : Diagnosis Procedure... CHANGEOVER SWITCH : Component Inspec- tion	72 73
		MIRROR SWITCH	73
		MIRROR SWITCH : Description	74
		MIRROR SWITCH : Component Function Check... MIRROR SWITCH : Component Function Check...	74 74

MIRROR SWITCH : Diagnosis Procedure	74	Diagnosis Procedure	102	
MIRROR SWITCH : Component Inspection	75			A
POWER SEAT SWITCH GROUND CIRCUIT77		RECLINING MOTOR	104	
Diagnosis Procedure	77	Description	104	B
		Component Function Check	104	B
		Diagnosis Procedure	104	
TILT & TELESCOPIC SWITCH GROUND CIRCUIT	78	LIFTING MOTOR (FRONT)	106	
Diagnosis Procedure	78	Description	106	C
		Component Function Check	106	
		Diagnosis Procedure	106	
FRONT DOOR SWITCH (DRIVER SIDE)	79	LIFTING MOTOR (REAR)	108	
Description	79	Description	108	D
Component Function Check	79	Component Function Check	108	
Diagnosis Procedure	79	Diagnosis Procedure	108	E
Component Inspection	80			
SLIDING SENSOR	81	TILT MOTOR	110	
Description	81	Description	110	F
Component Function Check	81	Component Function Check	110	
Diagnosis Procedure	81	Diagnosis Procedure	110	
RECLINING SENSOR	84	TELESCOPIC MOTOR	112	
Description	84	Description	112	G
Component Function Check	84	Component Function Check	112	
Diagnosis Procedure	84	Diagnosis Procedure	112	H
LIFTING SENSOR (FRONT)	87	DOOR MIRROR MOTOR	114	
Description	87	Description	114	I
Component Function Check	87	Component Function Check	114	
Diagnosis Procedure	87	Diagnosis Procedure	114	
		Component Inspection	115	
LIFTING SENSOR (REAR)	90	SEAT MEMORY INDICATOR	116	ADP
Description	90	Description	116	
Component Function Check	90	Component Function Check	116	
Diagnosis Procedure	90	Diagnosis Procedure	116	K
TILT SENSOR	93	ECU DIAGNOSIS INFORMATION	118	
Description	93			L
Component Function Check	93	DRIVER SEAT CONTROL UNIT	118	
Diagnosis Procedure	93	Reference Value	118	
		Wiring Diagram - AUTOMATIC DRIVE POSITIONER CONTROL SYSTEM -	124	M
TELESCOPIC SENSOR	95	Fail Safe	135	
Description	95	DTC Index	136	
Component Function Check	95			N
Diagnosis Procedure	95	AUTOMATIC DRIVE POSITIONER CONTROL UNIT	137	
MIRROR SENSOR	98	Reference Value	137	O
		Wiring Diagram - AUTOMATIC DRIVE POSITIONER CONTROL SYSTEM -	140	
DRIVER SIDE	98	BCM (BODY CONTROL MODULE)	152	P
DRIVER SIDE : Description	98	Reference Value	152	
DRIVER SIDE : Component Function Check	98	Wiring Diagram - BCM -	175	
DRIVER SIDE : Diagnosis Procedure	98	Fail-safe	181	
		DTC Inspection Priority Chart	183	
PASSENGER SIDE	99	DTC Index	183	
PASSENGER SIDE : Description	99	SYMPTOM DIAGNOSIS	186	
PASSENGER SIDE :				
Component Function Check	99			
PASSENGER SIDE : Diagnosis Procedure	100			
SLIDING MOTOR	102			
Description	102			
Component Function Check	102			

ADP SYSTEM SYMPTOMS	186	ALL COMPONENTS OF TILT & TELESCOPIC SWITCH DO NOT OPERATE	197
Symptom Table	186	Diagnosis Procedure	197
ALL PARTS DO NOT OPERATE IN MEMORY FUNCTION	187	NORMAL OPERATING CONDITION	198
Diagnosis Procedure	187	Description	198
MEMORY INDICATE DOES NOT OPERATE ..	188	PRECAUTION	199
Diagnosis Procedure	188	PRECAUTIONS	199
ALL COMPONENTS OF POWER SEAT DO NOT OPERATE	189	FOR USA AND CANADA	199
Diagnosis Procedure	189	FOR USA AND CANADA : Precaution for Supplemental Restraint System (SRS) "AIR BAG" and "SEAT BELT PRE-TENSIONER"	199
MANUAL FUNCTION OR MEMORY FUNCTION DOES NOT OPERATE	190	FOR MEXICO	199
SEAT SLIDING	190	FOR MEXICO : Precaution for Supplemental Restraint System (SRS) "AIR BAG" and "SEAT BELT PRE-TENSIONER"	199
SEAT SLIDING : Diagnosis Procedure	190	REMOVAL AND INSTALLATION	201
SEAT RECLINING	190	DRIVER SEAT CONTROL UNIT	201
SEAT RECLINING : Diagnosis Procedure	190	Exploded View	201
SEAT LIFTING (FRONT)	191	Removal and Installation	201
SEAT LIFTING (FRONT) : Diagnosis Procedure ..	191	AUTOMATIC DRIVE POSITIONER CONTROL UNIT	202
SEAT LIFTING (REAR)	192	Exploded View	202
SEAT LIFTING (REAR) : Diagnosis Procedure	192	Removal and Installation	202
STEERING TILT	192	SEAT MEMORY SWITCH	203
STEERING TILT : Diagnosis Procedure	192	Exploded View	203
STEERING TELESCOPIC	193	Removal and Installation	203
STEERING TELESCOPIC : Diagnosis Procedure.	193	POWER SEAT SWITCH	204
DOOR MIRROR	194	Exploded View	204
DOOR MIRROR : Diagnosis Procedure	194	Removal and Installation	204
ENTRY/EXIT ASSIST FUNCTION DOES NOT OPERATE	195	TILT&TELESCOPIC SWITCH	205
Diagnosis Procedure	195	Exploded View	205
INTELLIGENT KEY INTERLOCK FUNCTION DOES NOT OPERATE	196	Removal and Installation	205
Diagnosis Procedure	196		

DIAGNOSIS AND REPAIR WORK FLOW

< BASIC INSPECTION >

BASIC INSPECTION

DIAGNOSIS AND REPAIR WORK FLOW

Work Flow

INFOID:000000006257968

OVERALL SEQUENCE

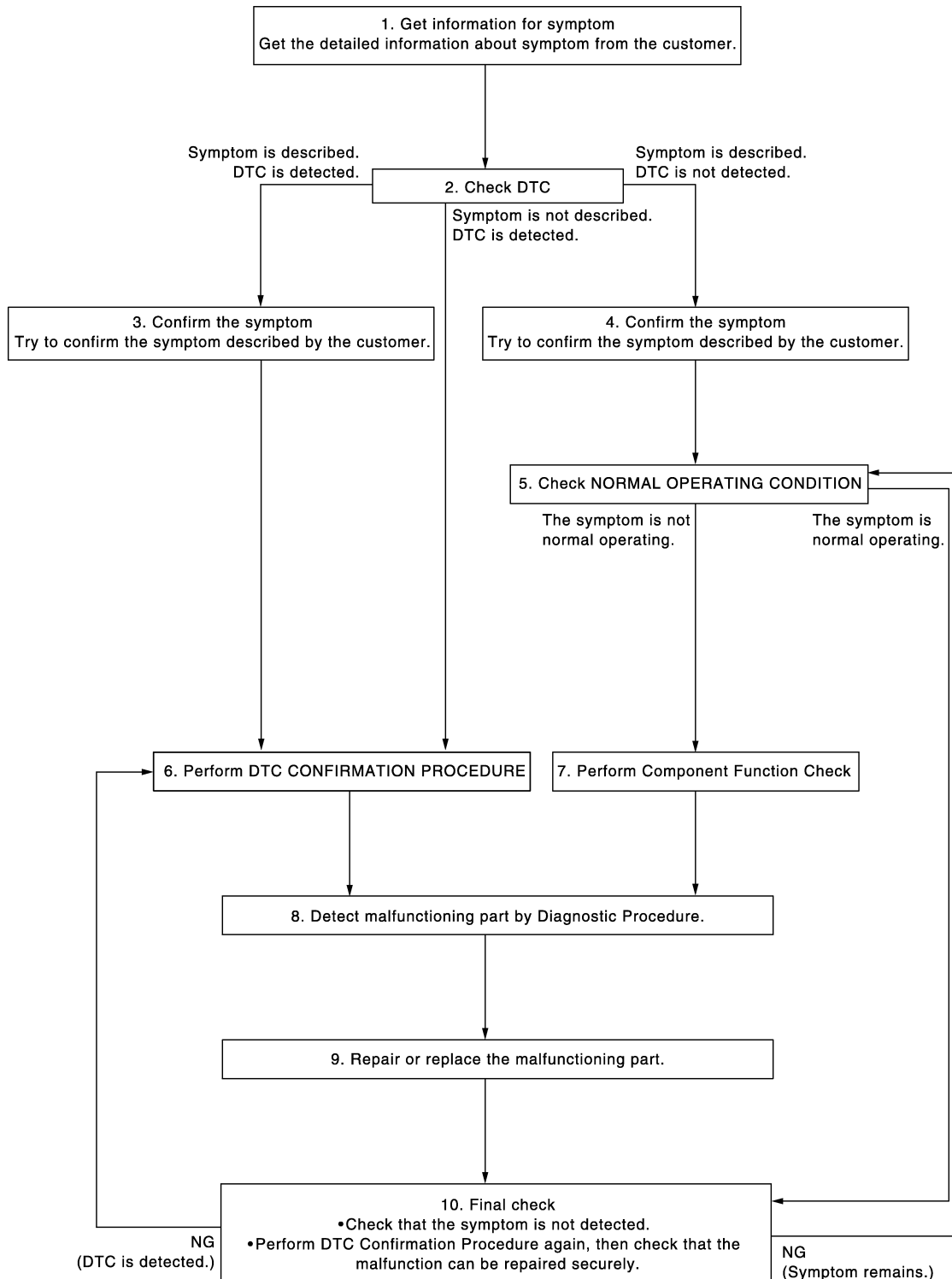

JMJIA1702GB

DETAILED FLOW

A
B
C
D
E
F
G
H
I
K
L
M
N
O
P

ADP

DIAGNOSIS AND REPAIR WORK FLOW

< BASIC INSPECTION >

1.GET INFORMATION FOR SYMPTOM

Get the detailed information from the customer about the symptom (the condition and the environment when the incident/malfunction occurred).

>> GO TO 2.

2.CHECK DTC WITH AUTOMATIC DRIVE POSITIONER SYSTEM

Check "Self Diagnostic Result" with CONSULT-III. Refer to [ADP-136, "DTC Index"](#)

Is any symptom described and any DTC is displayed?

Symptom is described, DTC is displayed.>>GO TO 3.

Symptom is not described, DTC is displayed.>>GO TO 6.

Symptom is described, DTC is not displayed.>>GO TO 4.

3.CONFIRM THE SYMPTOM

Try to confirm the symptom described by the customer.

>> GO TO 6.

4.CONFIRM THE SYMPTOM

Try to confirm the symptom described by the customer.

>> GO TO 5.

5.CHECK NORMAL OPERATING CONDITION

Check normal operating condition. Refer to [ADP-198, "Description"](#).

Is the incident normal operation?

YES >> INSPECTION END

NO >> GO TO 7.

6.PERFORM DTC CONFIRMATION PROCEDURE

Perform the confirmation procedure for the detected DTC.

Is the DTC displayed?

YES >> GO TO 8.

NO >> Check intermittent incident. Refer to [GI-44, "Intermittent Incident"](#).

7.PERFORM COMPONENT FUNCTION CHECK

Perform the component function check for the isolated malfunctioning point.

>> GO TO 8.

8.DETECT MALFUNCTIONING PART BY DIAGNOSTIC PROCEDURE

Isolate the malfunctioning point by performing the diagnosis procedure relevant to the symptom during the component diagnosis.

>> GO TO 9.

9.REPARE OR REPLACE THE MALFUNCTIONING PARTS

Repair or replace the malfunctioning part.

>> GO TO 10.

10.FINAL CHECK

Perform the DTC confirmation procedure (if DTC is detected) or component function check (if no DTC is detected) again, and then check that the malfunction can be repaired securely.

Are all malfunctions corrected?

DIAGNOSIS AND REPAIR WORK FLOW

< BASIC INSPECTION >

YES >> INSPECTION END
Symptom is detected.>> GO TO 5.
DTC is detected.>> GO TO 6.

A

B

C

D

E

F

G

H

I

ADP

K

L

M

N

O

P

INSPECTION AND ADJUSTMENT

< BASIC INSPECTION >

INSPECTION AND ADJUSTMENT

ADDITIONAL SERVICE WHEN REMOVING BATTERY NEGATIVE TERMINAL

ADDITIONAL SERVICE WHEN REMOVING BATTERY NEGATIVE TERMINAL : Description

INFOID:000000006257969

Each function is reset to the following condition when the battery terminal is disconnected.

Function	Condition	Procedure
Memory (Seat, steering, mirror)	Erased	Perform storing
Entry/exit assist	OFF	Perform initialization
		Set slide amount* ¹
Intelligent Key interlock	Erased	Perform initialization
		Perform storing

*¹: Default value is 40mm.

NOTE:

Notice that disconnecting the battery when detected DTC are present will erase the DTC memory.

ADDITIONAL SERVICE WHEN REMOVING BATTERY NEGATIVE TERMINAL : Special Repair Requirement

INFOID:000000006257970

1.SYSTEM INITIALIZATION

Perform system initialization. Refer to [ADP-9. "SYSTEM INITIALIZATION : Description"](#).

>> GO TO 2.

2.SYSTEM SETTING

Perform system setting. Refer to [ADP-11. "SYSTEM SETTING : Description"](#).

>> GO TO 3.

3.MEMORY STORAGE

Perform memory storage. Refer to [ADP-9. "MEMORY STORING : Description"](#).

>> END

ADDITIONAL SERVICE WHEN REPLACING CONTROL UNIT

ADDITIONAL SERVICE WHEN REPLACING CONTROL UNIT : Description

INFOID:000000006257971

Each function is reset to the following condition when the driver seat control unit is replaced.

Function	Condition	Procedure
Memory (Seat, steering, mirror)	Erased	Perform storing
Entry/exit assist	OFF	Perform initialization
		Set slide amount* ¹
Intelligent Key interlock	Erased	Perform initialization
		Perform storing

*¹: Default value is 40mm.

NOTE:

Notice that disconnecting the battery when detected DTC are present will erase the DTC memory.

ADDITIONAL SERVICE WHEN REPLACING CONTROL UNIT : Special Repair Re-

INSPECTION AND ADJUSTMENT

< BASIC INSPECTION >

requirement

INFOID:000000006257972

1. SYSTEM INITIALIZATION

Perform system initialization. Refer to [ADP-9, "SYSTEM INITIALIZATION : Description"](#).

>> GO TO 2.

2. SYSTEM SETTING

Perform system setting. Refer to [ADP-11, "SYSTEM SETTING : Description"](#).

>> GO TO 3.

3. MEMORY STORAGE

Perform memory storage. Refer to [ADP-9, "MEMORY STORING : Description"](#).

>> END

SYSTEM INITIALIZATION

SYSTEM INITIALIZATION : Description

INFOID:000000006257973

Always perform the initialization when the battery terminal is disconnected or the driver seat control unit is replaced.

The entry/exit assist function will not operate normally if no initialization is performed.

SYSTEM INITIALIZATION : Special Repair Requirement

INFOID:000000006257974

INITIALIZATION PROCEDURE

1. CHOOSE METHOD

There are two initialization methods.

Which method do you use?

With door switch>>GO TO 2.

With vehicle speed>>GO TO 4.

2. STEP A-1

Turn ignition switch from ACC to OFF position.

>> GO TO 3.

3. STEP A-2

Driver door switch is ON (open) → OFF (close) → ON (open).

>> END

4. STEP B-1

Drive the vehicle at more than 25 km/h (16 MPH).

>> END

MEMORY STORING

MEMORY STORING : Description

INFOID:000000006257975

Always perform the memory storage when the battery terminal is disconnected or the driver seat control unit is replaced. The memory function and Intelligent Key interlock function will not operate normally if no memory storage is performed.

A
B
C
D
E
F
G
H
I

ADP

K
L
M
N
O
P

INSPECTION AND ADJUSTMENT

< BASIC INSPECTION >

MEMORY STORING : Special Repair Requirement

INFOID:000000006257976

Memory Storage Procedure

Two positions for the driver seat, steering column and outside mirror can be stored for memory operation by following procedure.

1. STEP 1

Shift AT selector lever to P position.

>> GO TO 2.

2. STEP 2

Turn ignition switch ON.

>> GO TO 3.

3. STEP 3

Adjust driver seat, steering column and outside mirror position manually.

>> GO TO 4.

4. STEP 4

1. Push set switch.

NOTE:

- Memory indicator for which driver seat position is already retained in memory is illuminated for 5 seconds.
- Memory indicator for which driver seat position is not retained in memory is illuminated for 0.5 second.

2. Push the memory switch (1 or 2) for at least 1 second within 5 seconds after pushing the set switch.

NOTE:

- To enter driver seat positions into blank memory, memory indicator will be turned on for 5 seconds.
- To modify driver seat positions, memory indicator will be turned OFF for 0.5 second, then turned ON for 5 seconds.

NOTE:

If memory is stored in the same memory switch, the previous memory will be deleted.

Do you need linking of Intelligent Key?

YES >> GO TO 6.

NO >> GO TO 5.

5. STEP 5

Confirm the operation of each part with memory operation.

>> END

6. STEP 6

Push the Intelligent Key unlock button within 5 seconds after pushing memory switch (while the memory indicator is turned ON).

>> GO TO 7.

7. STEP 7

Confirm the operation of each part with memory operation and Intelligent Key interlock operation.

>> END

SYSTEM SETTING

INSPECTION AND ADJUSTMENT

< BASIC INSPECTION >

SYSTEM SETTING : Description

INFOID:000000006257977

The settings of the automatic driving positioner system can be changed, using CONSULT-III, the display unit in the center of the instrument panel and the set switch. Always check the settings before and after disconnecting the battery terminal or replacing driver seat control unit.

Setting Change

x: Applicable

Item	Content	CONSULT -III	Set switch	Factory setting
Amount of seat sliding for entry/exit assist	The amount of seat sliding for entry/exit assist can be selected from 3 items. [40mm/80mm/150mm]	x	—	40mm
Entry/exit assist (seat)	Entry/exit assist (seat) can be selected: ON (operated) – OFF (not operated)	x	x	ON
Entry/exit assist (steering column)	Entry/exit assist (steering column) can be selected: ON (operated) – OFF (not operated)	x		ON
Reset custom settings	All settings can be set to default (factory setting).	—	—	—

SYSTEM SETTING : Special Repair Requirement

INFOID:000000006257978

1. CHOOSE METHOD

There are three way of setting method.

Which method do you choose?

With set switch>>GO TO 2.

With CONSULT-III>>GO TO 4.

2. WITH SET SWITCH - STEP 1

Turn ignition switch OFF.

>> GO TO 3.

3. WITH SET SWITCH - STEP 2

Push setting button and hold for more than 10 seconds, then confirm blinking of the memory switch indicator.

- Entry/exit assist (seat/steering column) are ON: Memory switch indicator blink two times.
- Entry/exit assist (seat/steering column) are OFF: Memory switch indicator blink once.

>> END

4. WITH CONSULT-III - STEP 1

Select "Work support".

>> GO TO 5.

5. WITH CONSULT-III - STEP 2

1. Select "EXIT SEAT SLIDE SETTING", "EXIT TILT SETTING" or "SEAT SLIDE VOLUME SET" then touch display to change between ON and OFF.
 - EXIT SEAT SLIDE SETTING: Entry/exit assist (seat)
 - EXIT TILT SETTING: Entry/exit assist (steering column)
2. Then touch "OK".

>> END

AUTOMATIC DRIVE POSITIONER SYSTEM

< SYSTEM DESCRIPTION >

SYSTEM DESCRIPTION

AUTOMATIC DRIVE POSITIONER SYSTEM

AUTOMATIC DRIVE POSITIONER SYSTEM

AUTOMATIC DRIVE POSITIONER SYSTEM : System Diagram

INFOID:000000006257979

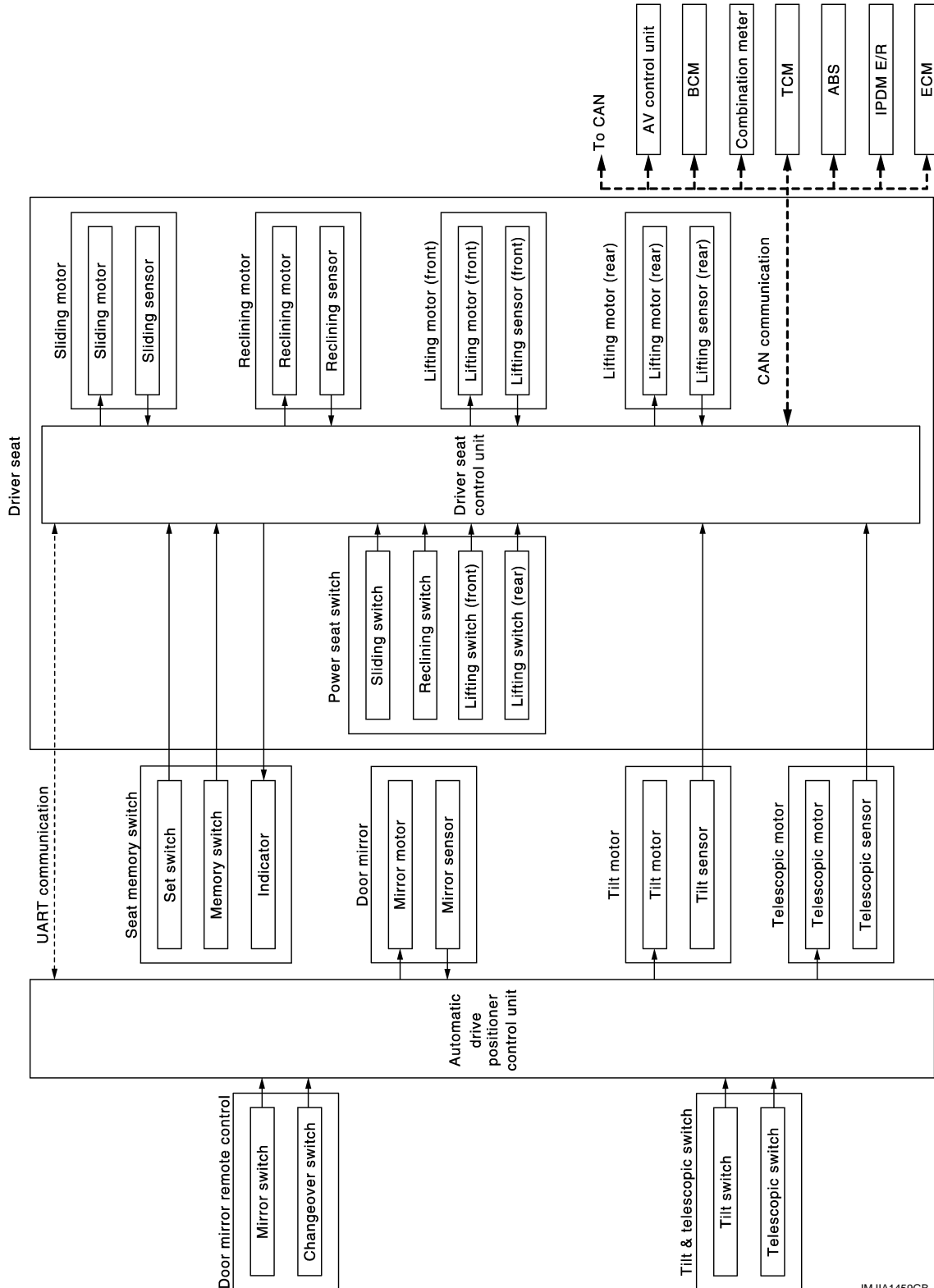

JMJIA1459GB

AUTOMATIC DRIVE POSITIONER SYSTEM

< SYSTEM DESCRIPTION >

AUTOMATIC DRIVE POSITIONER SYSTEM : System Description

INFOID:000000006257980

OUTLINE

The system automatically moves the driver seat, steering column and door mirror position by the driver seat control unit and the automatic drive positioner control unit. The driver seat control unit corresponds with the automatic drive positioner control unit by UART communication.

Function		Description
Manual function		The driving position (seat, steering column and door mirror position) can be adjusted by using the power seat switch, tilt & telescopic switch or door mirror remote control switch.
Memory function		The seat, steering column and door mirror move to the stored driving position by pressing seat memory switch (1 or 2).
Entry/Exit assist function	Exit	On exit, the seat moves backward and the steering column moves upward.
	Entry	On entry, the seat and steering column returns from exiting position to the previous driving position.
Intelligent Key interlock function		Perform memory operation, exiting operation and entry operation by Intelligent Key unlock operation or driver side door request switch unlock operation.

NOTE:

The lumbar support system and the side support system are controlled independently with no link to the automatic drive positioner system.

A
B
C
D
E
F
G
H
I
K
L
M
N
O
P

ADP

AUTOMATIC DRIVE POSITIONER SYSTEM

< SYSTEM DESCRIPTION >

AUTOMATIC DRIVE POSITIONER SYSTEM : Component Parts Location INFOID:000000006257981

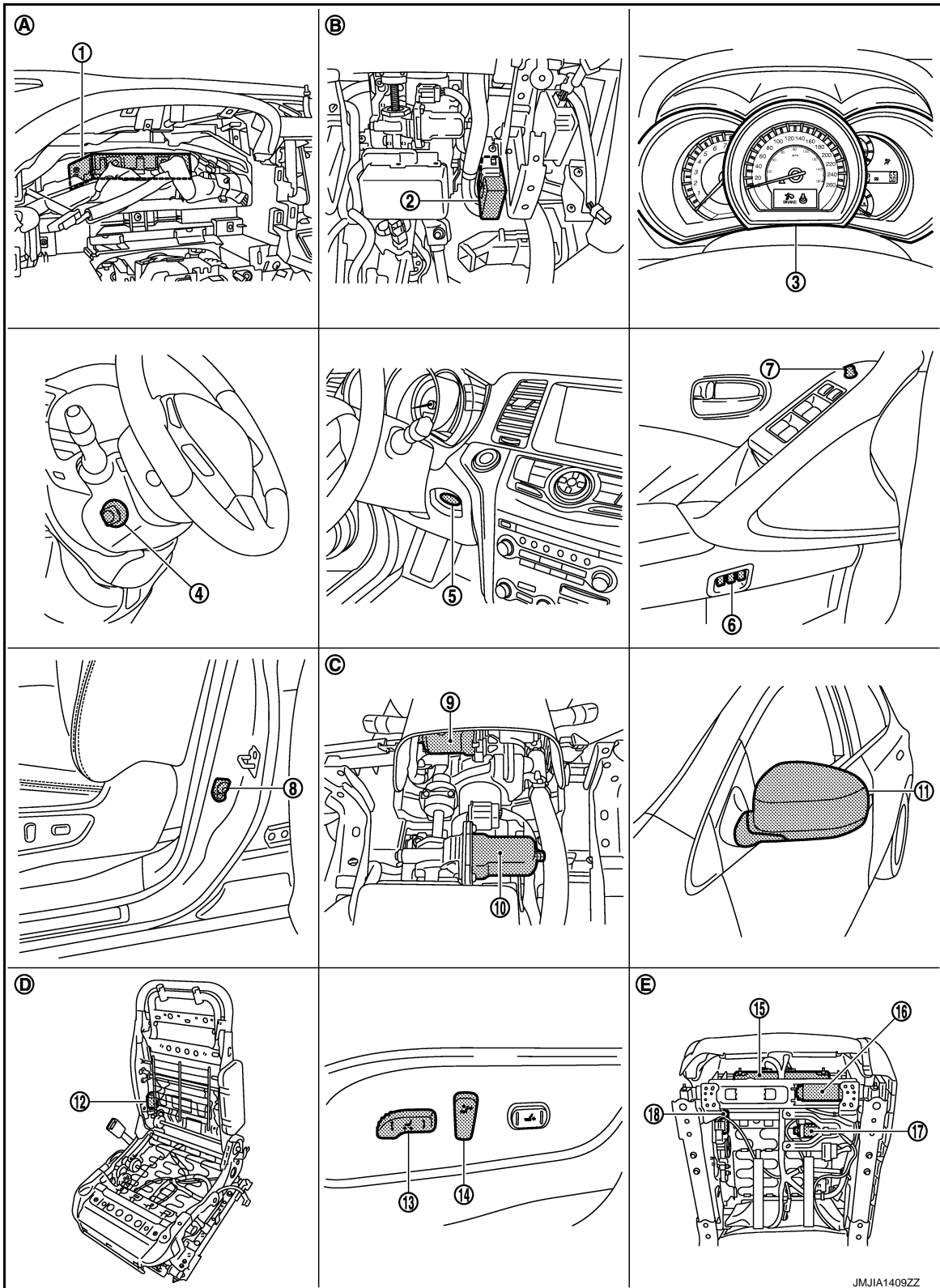

JMJIA1409ZZ

- | | | |
|--|--|---------------------------|
| 1. BCM M118, M119, M122, M123 | 2. Automatic drive positioner control unit M75, M104 | 3. Combination meter |
| 4. Tilt & telescopic switch M102 | 5. Key slot M99 | 6. Seat memory switch D13 |
| 7. Door mirror remote control switch D14 | 8. Front door switch (driver side) B34 | 9. Tilt motor M116 |

AUTOMATIC DRIVE POSITIONER SYSTEM

< SYSTEM DESCRIPTION >

- | | | |
|---|--|--|
| 10. Telescopic motor M117 | 11. Door mirror (driver side) D3 | 12. Reclining motor B461 |
| 13. Sliding, Lifting switch
(Power seat switch B459) | 14. Reclining switch
(Power seat switch B459) | 15. Driver seat control unit B451,B452 |
| 16. Sliding motor B461 | 17. Lifting motor (front) B455 | 18. Lifting motor (rear) B456 |
| A. Behind the combination meter | B. View with instrument driver lower panel removed | C. View with instrument driver lower panel removed |
| D. View with seat cushion and seatback pad removed | E. Backside of the seat cushion | |

AUTOMATIC DRIVE POSITIONER SYSTEM : Component Description

INFOID:000000006257982

CONTROL UNITS

Item	Function
Driver seat control unit	<ul style="list-style-type: none"> Main units of automatic drive positioner system It is connected to the CAN. It communicates with the automatic drive positioner control via UART communication.
Automatic drive positioner control unit	<ul style="list-style-type: none"> It communicates with the driver seat control unit via UART communication. Perform various controls with the instructions of driver seat control unit. Perform the controls of the tilt & telescopic, door mirror switch.
BCM	Transmit the following status to the driver seat control unit via CAN communication. <ul style="list-style-type: none"> Driver door: OPEN/CLOSE Ignition switch position: ACC/ON Door lock: UNLOCK (with Intelligent Key or driver side door request switch operation) Key ID Key switch: Insert/Pull out Intelligent Key Starter: CRANKING/OTHER Handle position : LHD
Combination meter / ABS	Transmit the vehicle speed signal to the driver seat control unit via CAN communication.
AV control unit	The setting change of auto drive positioner system can be performed on the display.
TCM	Transmit the shift position signal (P range) to the driver seat control unit via CAN communication.

INPUT PARTS

Switches

Item	Function
Key slot	The key switch is installed to detect the key inserted/removed status.
Front door switch (driver side)	Detect front door (driver side) open/close status.
CVT shift selector (detention switch)	Detect the P range position of A/T selector lever.
Set switch	The registration and system setting can be performed with its operation.
Memory switch 1/2	The registration and operation can be performed with its operation.
Power seat switch	The following switch is installed. <ul style="list-style-type: none"> Reclining switch Lifting switch (front) Lifting switch (rear) Sliding switch The specific parts can be operated with the operation of each switch.

AUTOMATIC DRIVE POSITIONER SYSTEM

< SYSTEM DESCRIPTION >

Item	Function
Tilt & telescopic switch	The following switch is installed. <ul style="list-style-type: none"> • Tilt switch • Telescopic switch The specific parts can be operated with the operation of each switch.
Door mirror remote control switch	The following switch is installed. <ul style="list-style-type: none"> • Mirror switch • Changeover switch The specific parts can be operated with the operation of each switch.

Sensors

Item	Function
Door mirror sensor (driver side/passenger side)	Detect the up/down and left/right position of outside mirror face.
Tilt and telescopic sensor	Detect the up/down and left/right position of steering column.
Lifting sensor (front)	Detect the up/down position of seat lifting (front).
Lifting sensor (rear)	Detect the up/down position of seat lifting (rear).
Reclining sensor	Detect the tilt of seatback.
Sliding sensor	Detect the front/rear position of seat.

OUTPUT PARTS

Item	Function
Door mirror motor (driver side/passenger side)	Move the outside mirror face upward/downward and leftward/rightward.
Tilt and telescopic motor	Move the steering column upward/downward and frontward/rearward.
Lifting motor (front)	Move the seat lifting (front) upward/downward.
Lifting motor (rear)	Move the seat lifting (rear) upward/downward.
Reclining motor	Tilt and raise up the seatback.
Sliding motor	Slide the seat frontward/rearward.
Memory indicator	Illuminates or flashes according to the registration/operation status.

MANUAL FUNCTION

AUTOMATIC DRIVE POSITIONER SYSTEM

< SYSTEM DESCRIPTION >

MANUAL FUNCTION : System Diagram

INFOID:000000006257983

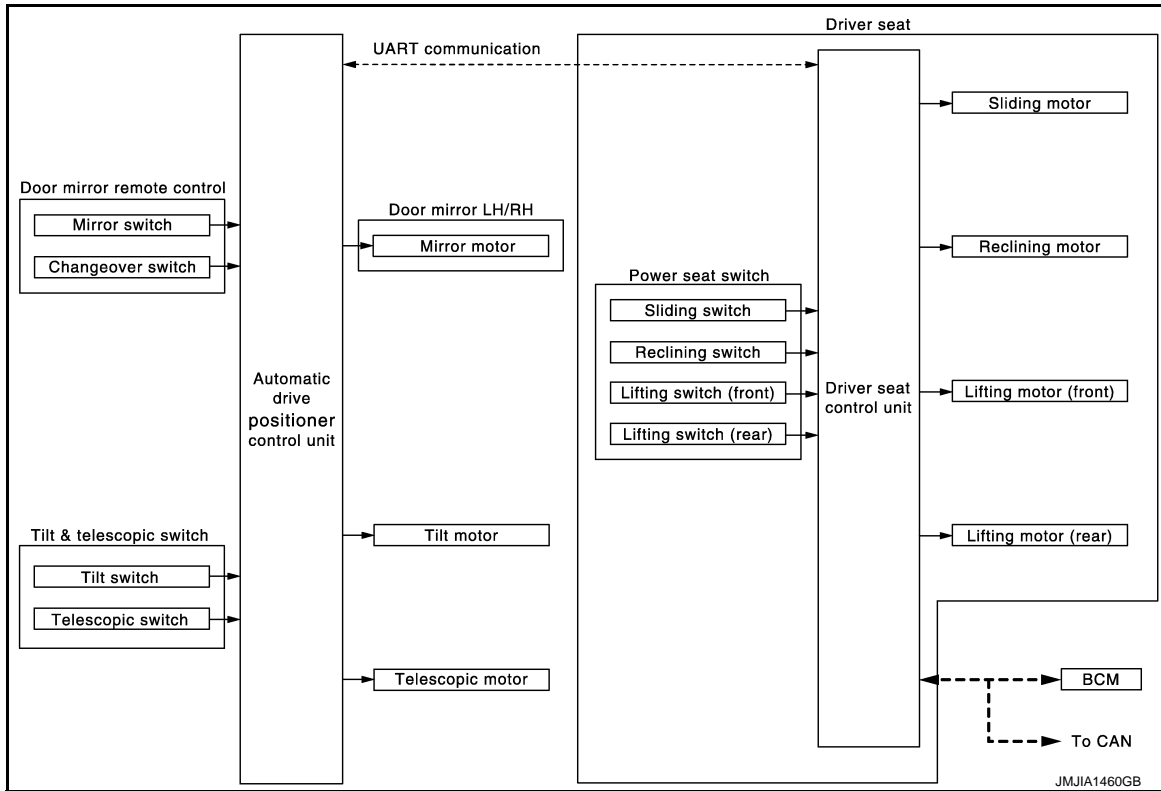

A
B
C
D
E
F
G
H

MANUAL FUNCTION : System Description

INFOID:000000006257984

OUTLINE

The driving position (seat, steering column and door mirror position) can be adjusted manually with power seat switch, tilt & telescopic switch and door mirror remote control switch.

ADP

OPERATION PROCEDURE

1. Turn ignition switch ON.
2. Operate power seat switch, tilt & telescopic switch or door mirror remote control switch.
3. The driver seat, steering column or door mirror operates according to the operation of each switch.

NOTE:

Seat operates only up to two places at the same time.

K
L

DETAIL FLOW

Seat

Order	Input	Output	Control unit condition
1	Power seat switch (sliding, lifting, reclining)	—	The power seat switch signal is inputted to the driver seat control unit when the power seat switch is operated.
2	—	Motors (sliding, lifting, reclining)	The driver seat control unit outputs signals to each motor according to the power seat switch input signal.

M
N
O
P

Tilt & Telescopic

AUTOMATIC DRIVE POSITIONER SYSTEM

< SYSTEM DESCRIPTION >

Order	Input	Output	Control unit condition
1	Tilt & telescopic switch	—	The tilt & telescopic switch signal is inputted to the automatic drive positioner control unit when the tilt & telescopic switch is operated.
2	—	Motors (Tilt, telescopic)	The automatic drive positioner control unit actuates each motor according to the operation of the tilt & telescopic switch.

Door Mirror

Order	Input	Output	Control unit condition
1	Door mirror remote control switch	—	The door mirror remote control switch signal is inputted to the automatic drive positioner control unit when the door mirror remote control switch is operated.
2	—	Motors (Door mirror motor)	The automatic drive positioner control unit actuates each motor according to the operation of the door mirror remote control switch.

NOTE:

The door mirrors can be operated manually when ignition switch is in either ACC or ON position. The ignition switch signal (ACC/ON) is transmitted from BCM to the driver seat control unit via CAN communication and from the driver seat control unit to the automatic drive positioner control unit via UART communication. UART communication line malfunction and CAN communication line malfunction are detected, the door mirror cannot be operated.

AUTOMATIC DRIVE POSITIONER SYSTEM

< SYSTEM DESCRIPTION >

MANUAL FUNCTION : Component Parts Location

INFOID:000000006257985

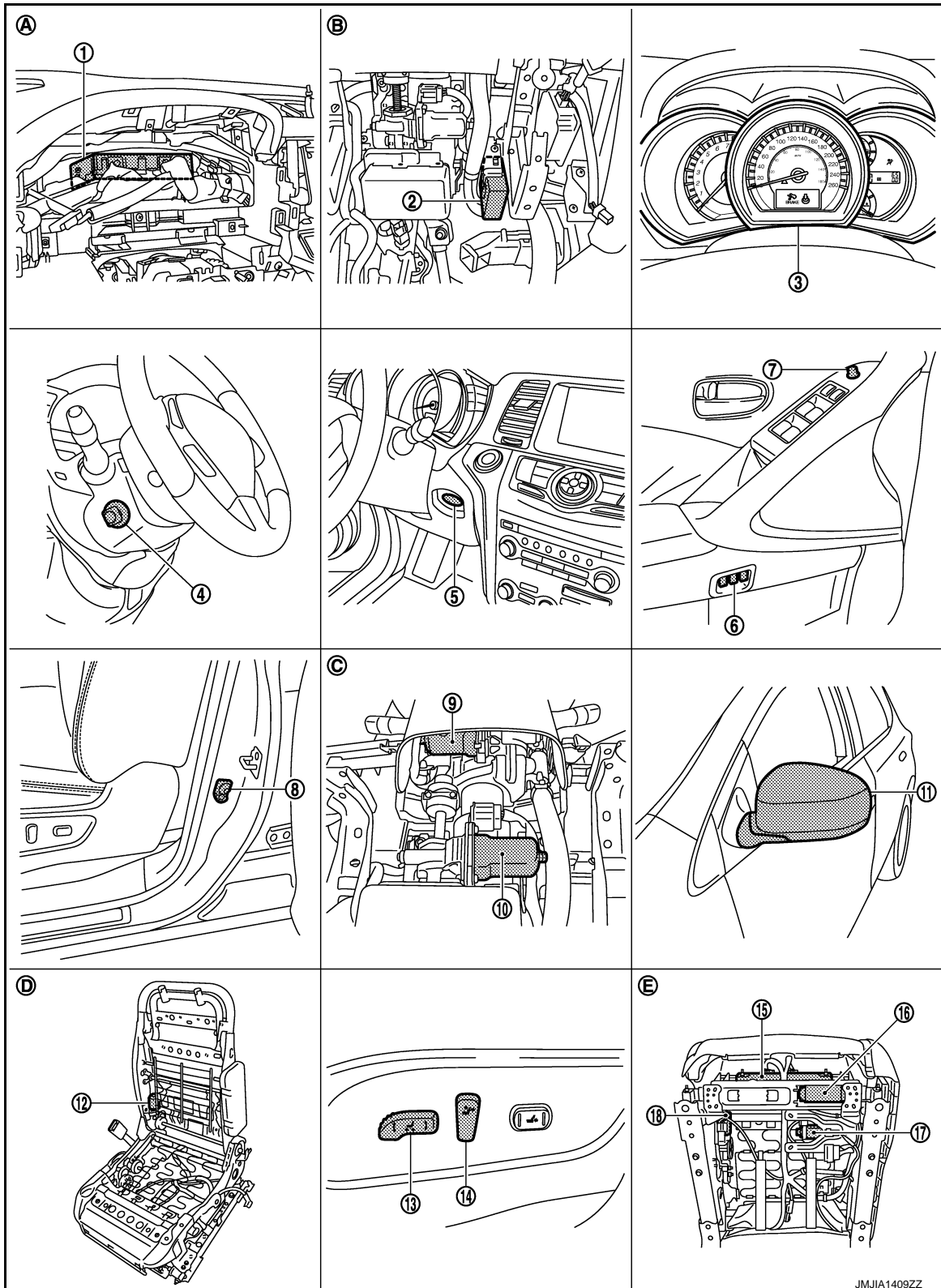

A
B
C
D
E
F
G
H
I
J
K
L
M
N
O
P

ADP

- | | | |
|--|--|---------------------------|
| 1. BCM M118, M119, M122, M123 | 2. Automatic drive positioner control unit M75, M104 | 3. Combination meter |
| 4. Tilt & telescopic switch M102 | 5. Key slot M99 | 6. Seat memory switch D13 |
| 7. Door mirror remote control switch D14 | 8. Front door switch (driver side) B34 | 9. Tilt motor M116 |

JMJIA1409ZZ

AUTOMATIC DRIVE POSITIONER SYSTEM

< SYSTEM DESCRIPTION >

- | | | |
|---|--|--|
| 10. Telescopic motor M117 | 11. Door mirror (driver side) D3 | 12. Reclining motor B461 |
| 13. Sliding, Lifting switch
(Power seat switch B459) | 14. Reclining switch
(Power seat switch B459) | 15. Driver seat control unit B451,B452 |
| 16. Sliding motor B461 | 17. Lifting motor (front) B455 | 18. Lifting motor (rear) B456 |
| A. Behind the combination meter | B. View with instrument driver lower panel removed | C. View with instrument driver lower panel removed |
| D. View with seat cushion and seatback pad removed | E. Backside of the seat cushion | |

MANUAL FUNCTION : Component Description

INFOID:000000006854205

CONTROL UNITS

Item	Function
Driver seat control unit	<ul style="list-style-type: none"> Main units of automatic drive positioner system It is connected to the CAN. It communicates with the automatic drive positioner control via UART communication.
Automatic drive positioner control unit	<ul style="list-style-type: none"> It communicates with the driver seat control unit via UART communication. Perform various controls with the instructions of driver seat control unit. Perform the controls of the tilt & telescopic, door mirror switch.
BCM	Transmit the following status to the driver seat control unit via CAN communication. <ul style="list-style-type: none"> Driver door: OPEN/CLOSE Ignition switch position: ACC/ON Door lock: UNLOCK (with Intelligent Key or driver side door request switch operation) Key ID Key switch: Insert/Pull out Intelligent Key Starter: CRANKING/OTHER Handle position : LHD
Combination meter / ABS	Transmit the vehicle speed signal to the driver seat control unit via CAN communication.
AV control unit	The setting change of auto drive positioner system can be performed on the display.
TCM	Transmit the shift position signal (P range) to the driver seat control unit via CAN communication.

INPUT PARTS

Switches

Item	Function
Key slot	The key switch is installed to detect the key inserted/removed status.
Front door switch (driver side)	Detect front door (driver side) open/close status.
CVT shift selector (detention switch)	Detect the P range position of A/T selector lever.
Set switch	The registration and system setting can be performed with its operation.
Memory switch 1/2	The registration and operation can be performed with its operation.
Power seat switch	The following switch is installed. <ul style="list-style-type: none"> Reclining switch Lifting switch (front) Lifting switch (rear) Sliding switch The specific parts can be operated with the operation of each switch.

AUTOMATIC DRIVE POSITIONER SYSTEM

< SYSTEM DESCRIPTION >

Item	Function
Tilt & telescopic switch	The following switch is installed. <ul style="list-style-type: none"> • Tilt switch • Telescopic switch The specific parts can be operated with the operation of each switch.
Door mirror remote control switch	The following switch is installed. <ul style="list-style-type: none"> • Mirror switch • Changeover switch The specific parts can be operated with the operation of each switch.

Sensors

Item	Function
Door mirror sensor (driver side/passenger side)	Detect the up/down and left/right position of outside mirror face.
Tilt and telescopic sensor	Detect the up/down and left/right position of steering column.
Lifting sensor (front)	Detect the up/down position of seat lifting (front).
Lifting sensor (rear)	Detect the up/down position of seat lifting (rear).
Reclining sensor	Detect the tilt of seatback.
Sliding sensor	Detect the front/rear position of seat.

OUTPUT PARTS

Item	Function
Door mirror motor (driver side/passenger side)	Move the outside mirror face upward/downward and leftward/rightward.
Tilt and telescopic motor	Move the steering column upward/downward and frontward/rearward.
Lifting motor (front)	Move the seat lifting (front) upward/downward.
Lifting motor (rear)	Move the seat lifting (rear) upward/downward.
Reclining motor	Tilt and raise up the seatback.
Sliding motor	Slide the seat frontward/rearward.
Memory indicator	Illuminates or flashes according to the registration/operation status.

MEMORY FUNCTION

A
B
C
D
E
F
G
H
I
K
L
M
N
O
P

ADP

AUTOMATIC DRIVE POSITIONER SYSTEM

< SYSTEM DESCRIPTION >

MEMORY FUNCTION : System Diagram

INFOID:000000006257987

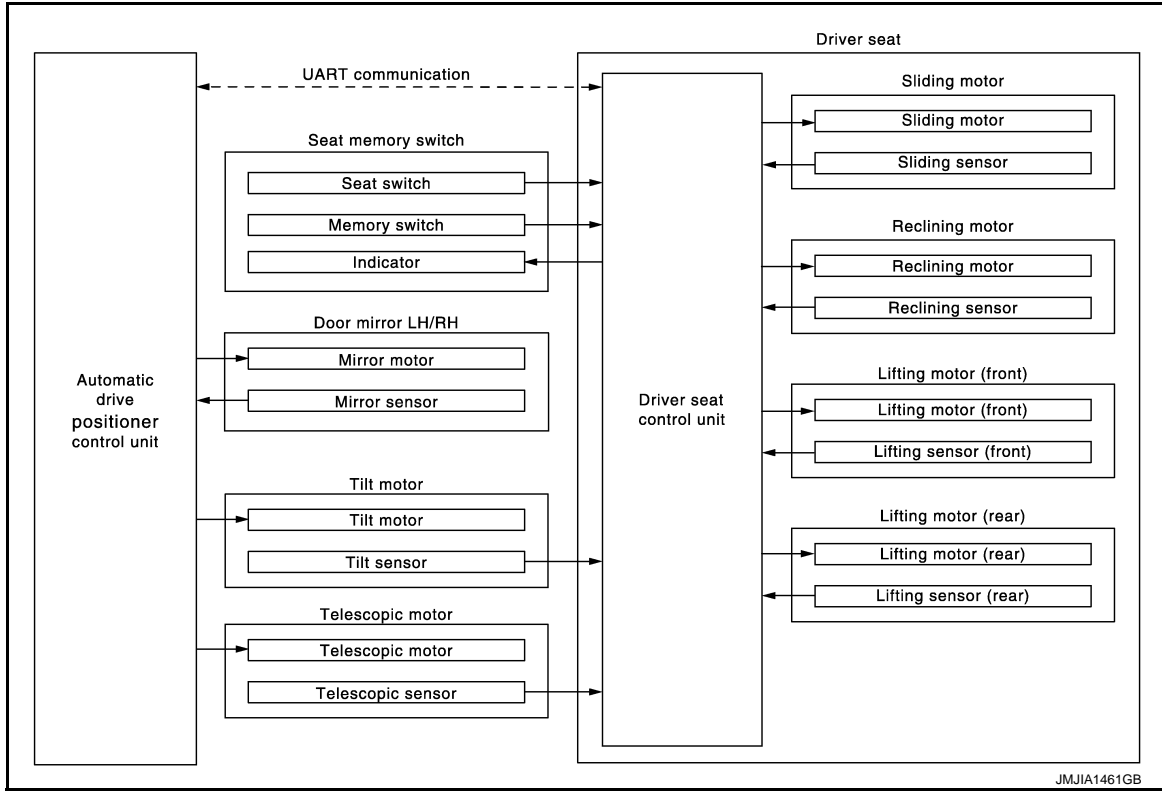

MEMORY FUNCTION : System Description

INFOID:000000006257988

OUTLINE

The driver seat control unit can store the optimum driving positions (seat, steering column and door mirror position) for 2 people. If the front seat position is changed, one-touch (pressing desired memory switch) operation allows changing to the other driving position.

NOTE:

Further information for the memory storage procedure. Refer to [ADP-9, "MEMORY STORING : Description"](#).

OPERATION PROCEDURE

1. Turn ignition switch ON
2. Shift position P position
3. Press desired memory switch.
4. Driver seat, steering and door mirror will move to the memorized position.

OPERATION CONDITION

Satisfy all of the following items. The memory function is not performed if these items are not satisfied.

Item	Request status
Ignition position	ON
Switch inputs <ul style="list-style-type: none"> • Power seat switch • Tilt & telescopic switch • Door mirror control switch • Set switch • Memory switch 	OFF (Not operated)
A/T selector lever	P position

However, the memory operation can be performed for 45 seconds after opening the driver door (driver door switch OFF → ON) even if the ignition switch position is in OFF position.

DETAIL FLOW

AUTOMATIC DRIVE POSITIONER SYSTEM

< SYSTEM DESCRIPTION >

Order	Input	Output	Control unit condition
1	Memory switch	—	The memory switch signal is inputted to the driver seat control unit when memory switch 1 or 2 is operated.
2	—	Motors (Seat, Steering, door mirror)	Driver seat control unit operates each motor of seat when it recognizes the memory switch pressed for 0.5 second or more and requests each motor operation to automatic drive positioner control unit via UART communication. The automatic drive positioner control unit operates each motor.
		Memory switch Indicator	Driver seat control unit requests the flashing of memory indicator while either of the motors is operating. The driver seat control unit illuminates the memory indicator.
3	Sensors (Seat, steering column, door mirror)	—	Driver seat control unit judges the operating seat position with each seat sensor input. The positions of the steering column and outside mirror are monitored with each sensor signal. Driver seat control unit stops the operation of each motor when each part reaches the recorded address.
4	—	Memory switch Indicator	Driver seat control unit requests the illumination of memory indicator after all motors stop. The driver seat control unit illuminates the memory indicator for 5 seconds.

A
B
C
D
E
F
G
H
I
K
L
M
N
O
P

ADP

AUTOMATIC DRIVE POSITIONER SYSTEM

< SYSTEM DESCRIPTION >

MEMORY FUNCTION : Component Parts Location

INFOID:000000006257989

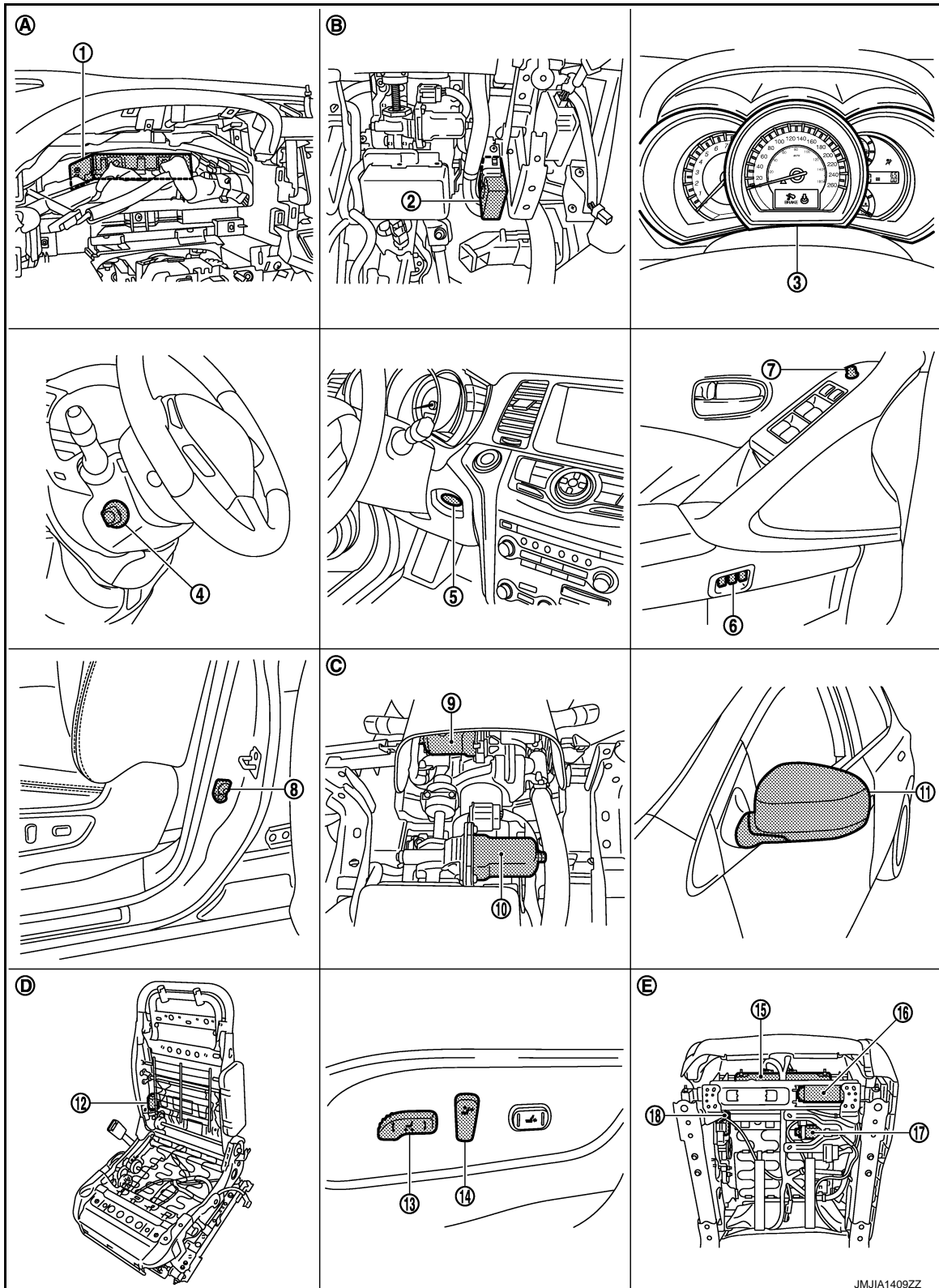

JMJIA1409ZZ

- | | | |
|--|--|---------------------------|
| 1. BCM M118, M119, M122, M123 | 2. Automatic drive positioner control unit M75, M104 | 3. Combination meter |
| 4. Tilt & telescopic switch M102 | 5. Key slot M99 | 6. Seat memory switch D13 |
| 7. Door mirror remote control switch D14 | 8. Front door switch (driver side) B34 | 9. Tilt motor M116 |

AUTOMATIC DRIVE POSITIONER SYSTEM

< SYSTEM DESCRIPTION >

- | | | |
|---|--|--|
| 10. Telescopic motor M117 | 11. Door mirror (driver side) D3 | 12. Reclining motor B461 |
| 13. Sliding, Lifting switch
(Power seat switch B459) | 14. Reclining switch
(Power seat switch B459) | 15. Driver seat control unit B451,B452 |
| 16. Sliding motor B461 | 17. Lifting motor (front) B455 | 18. Lifting motor (rear) B456 |
| A. Behind the combination meter | B. View with instrument driver lower panel removed | C. View with instrument driver lower panel removed |
| D. View with seat cushion and seatback pad removed | E. Backside of the seat cushion | |

MEMORY FUNCTION : Component Description

INFOID:000000006854206

CONTROL UNITS

Item	Function
Driver seat control unit	<ul style="list-style-type: none"> Main units of automatic drive positioner system It is connected to the CAN. It communicates with the automatic drive positioner control via UART communication.
Automatic drive positioner control unit	<ul style="list-style-type: none"> It communicates with the driver seat control unit via UART communication. Perform various controls with the instructions of driver seat control unit. Perform the controls of the tilt & telescopic, door mirror switch.
BCM	Transmit the following status to the driver seat control unit via CAN communication. <ul style="list-style-type: none"> Driver door: OPEN/CLOSE Ignition switch position: ACC/ON Door lock: UNLOCK (with Intelligent Key or driver side door request switch operation) Key ID Key switch: Insert/Pull out Intelligent Key Starter: CRANKING/OTHER Handle position : LHD
Combination meter / ABS	Transmit the vehicle speed signal to the driver seat control unit via CAN communication.
AV control unit	The setting change of auto drive positioner system can be performed on the display.
TCM	Transmit the shift position signal (P range) to the driver seat control unit via CAN communication.

INPUT PARTS

Switches

Item	Function
Key slot	The key switch is installed to detect the key inserted/removed status.
Front door switch (driver side)	Detect front door (driver side) open/close status.
CVT shift selector (detention switch)	Detect the P range position of A/T selector lever.
Set switch	The registration and system setting can be performed with its operation.
Memory switch 1/2	The registration and operation can be performed with its operation.
Power seat switch	The following switch is installed. <ul style="list-style-type: none"> Reclining switch Lifting switch (front) Lifting switch (rear) Sliding switch The specific parts can be operated with the operation of each switch.

AUTOMATIC DRIVE POSITIONER SYSTEM

< SYSTEM DESCRIPTION >

Item	Function
Tilt & telescopic switch	The following switch is installed. <ul style="list-style-type: none">• Tilt switch• Telescopic switch The specific parts can be operated with the operation of each switch.
Door mirror remote control switch	The following switch is installed. <ul style="list-style-type: none">• Mirror switch• Changeover switch The specific parts can be operated with the operation of each switch.

Sensors

Item	Function
Door mirror sensor (driver side/passenger side)	Detect the up/down and left/right position of outside mirror face.
Tilt and telescopic sensor	Detect the up/down and left/right position of steering column.
Lifting sensor (front)	Detect the up/down position of seat lifting (front).
Lifting sensor (rear)	Detect the up/down position of seat lifting (rear).
Reclining sensor	Detect the tilt of seatback.
Sliding sensor	Detect the front/rear position of seat.

OUTPUT PARTS

Item	Function
Door mirror motor (driver side/passenger side)	Move the outside mirror face upward/downward and leftward/rightward.
Tilt and telescopic motor	Move the steering column upward/downward and frontward/rearward.
Lifting motor (front)	Move the seat lifting (front) upward/downward.
Lifting motor (rear)	Move the seat lifting (rear) upward/downward.
Reclining motor	Tilt and raise up the seatback.
Sliding motor	Slide the seat frontward/rearward.
Memory indicator	Illuminates or flashes according to the registration/operation status.

EXIT ASSIST FUNCTION

AUTOMATIC DRIVE POSITIONER SYSTEM

< SYSTEM DESCRIPTION >

EXIT ASSIST FUNCTION : System Diagram

INFOID:000000006257991

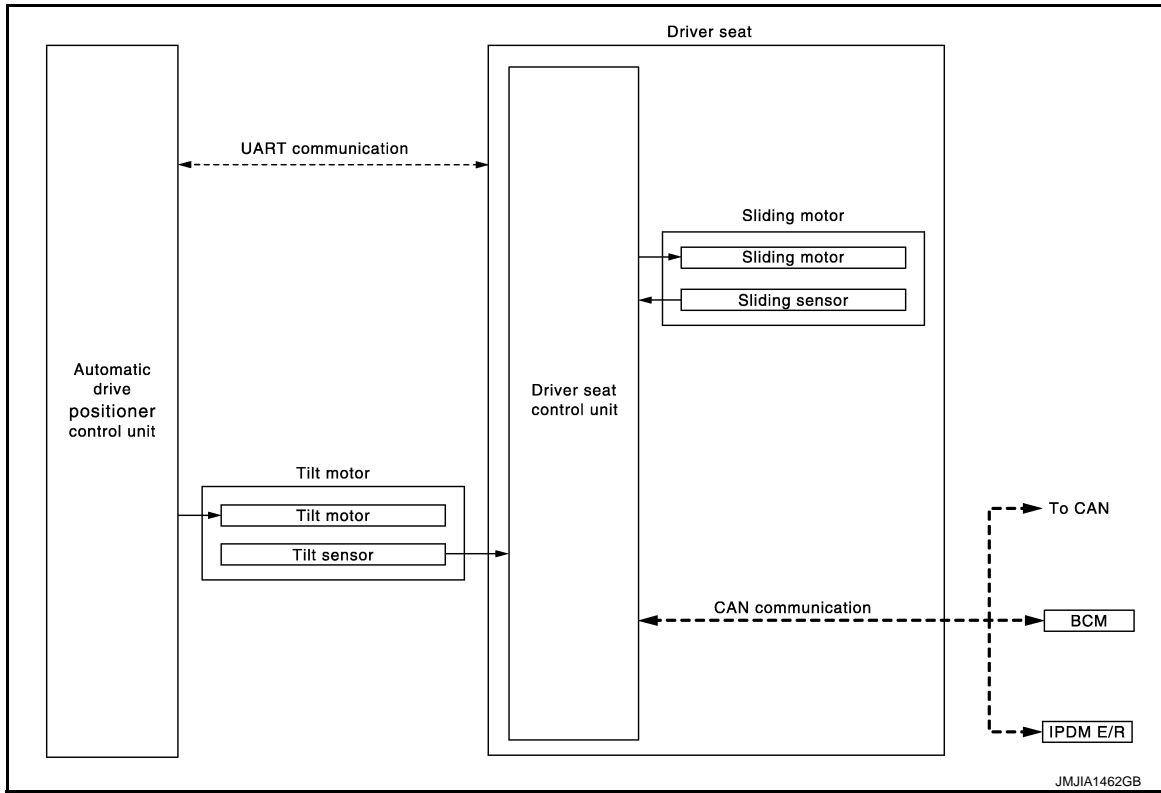

A
B
C
D
E
F
G
H

EXIT ASSIST FUNCTION : System Description

INFOID:000000006257992

OUTLINE

When exiting, the condition is satisfied, the seat is moved backward 40 mm (1.57 in) from normal sitting position and the steering is moved to the most upper position.

The seat slide amount and the steering operation at entry/exit operation can be changed.

NOTE:

- This function is set to ON before delivery (initial setting).
- Further information for the system setting procedure. Refer to [ADP-9, "SYSTEM INITIALIZATION : Description"](#).

ADP

OPERATION PROCEDURE

1. Open the driver door with ignition switch in OFF position. (Intelligent Key is not inserted into key slot)
2. Driver seat and steering column will move to the exiting position.

OPERATION CONDITION

Satisfy all of the following items. The exit assist function is not performed if these items are not satisfied.

Item	Request status
Ignition position	OFF
System setting [Entry/exit assist function (seat/steering)]	ON
Initialization	Done
Key switch	OFF (Intelligent Key is not inserted into key slot)
Switch inputs <ul style="list-style-type: none"> • Power seat switch • Tilt & telescopic switch • Door mirror remote control switch • Set switch • Memory switch 	OFF (Not operated)
A/T selector lever	P position

K
L
M
N
O
P

AUTOMATIC DRIVE POSITIONER SYSTEM

< SYSTEM DESCRIPTION >

DETAIL FLOW

Order	Input	Output	Control unit condition
1	Door switch (Driver side)	—	Driver seat control unit receives door switch signal (driver side/ open) from BCM via CAN communication.
2	—	Motors (Seat sliding, tilt)	Driver seat control unit operates the seat sliding motor, which recog- nizes that the driver side door is opened with ignition switch OFF. Driver seat control unit then requests the operations of tilt motor to auto drive positioner control unit via UART communication. The au- tomatic drive positioner control unit operates each motor for a con- stant amount.

AUTOMATIC DRIVE POSITIONER SYSTEM

< SYSTEM DESCRIPTION >

EXIT ASSIST FUNCTION : Component Parts Location

INFOID:000000006257993

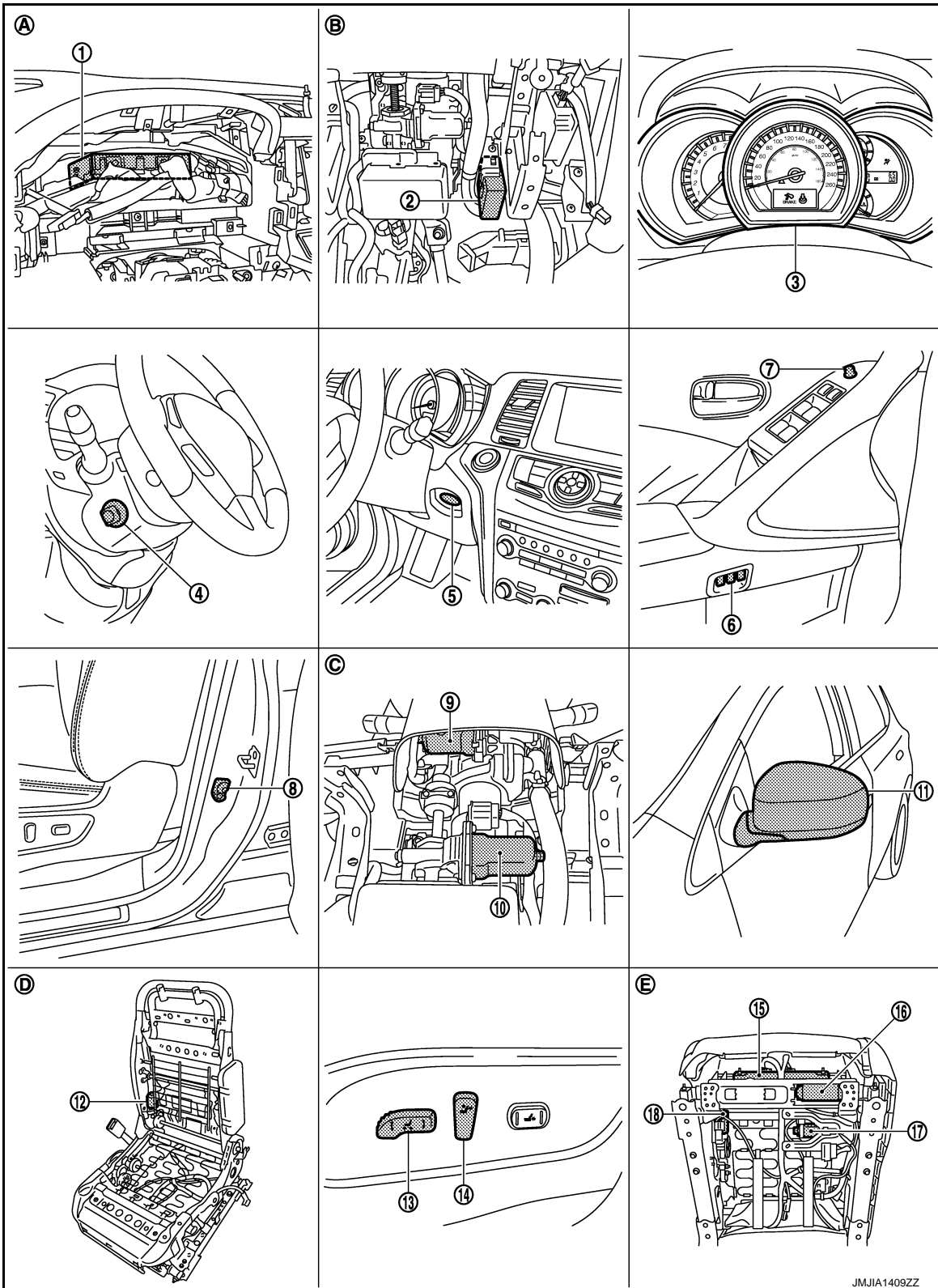

- | | | |
|--|--|---------------------------|
| 1. BCM M118, M119, M122, M123 | 2. Automatic drive positioner control unit M75, M104 | 3. Combination meter |
| 4. Tilt & telescopic switch M102 | 5. Key slot M99 | 6. Seat memory switch D13 |
| 7. Door mirror remote control switch D14 | 8. Front door switch (driver side) B34 | 9. Tilt motor M116 |

JMJIA1409ZZ

AUTOMATIC DRIVE POSITIONER SYSTEM

< SYSTEM DESCRIPTION >

- | | | |
|---|--|--|
| 10. Telescopic motor M117 | 11. Door mirror (driver side) D3 | 12. Reclining motor B461 |
| 13. Sliding, Lifting switch
(Power seat switch B459) | 14. Reclining switch
(Power seat switch B459) | 15. Driver seat control unit B451,B452 |
| 16. Sliding motor B461 | 17. Lifting motor (front) B455 | 18. Lifting motor (rear) B456 |
| A. Behind the combination meter | B. View with instrument driver lower panel removed | C. View with instrument driver lower panel removed |
| D. View with seat cushion and seatback pad removed | E. Backside of the seat cushion | |

EXIT ASSIST FUNCTION : Component Description

INFOID:000000006854207

CONTROL UNITS

Item	Function
Driver seat control unit	<ul style="list-style-type: none"> Main units of automatic drive positioner system It is connected to the CAN. It communicates with the automatic drive positioner control via UART communication.
Automatic drive positioner control unit	<ul style="list-style-type: none"> It communicates with the driver seat control unit via UART communication. Perform various controls with the instructions of driver seat control unit. Perform the controls of the tilt & telescopic, door mirror switch.
BCM	Transmit the following status to the driver seat control unit via CAN communication. <ul style="list-style-type: none"> Driver door: OPEN/CLOSE Ignition switch position: ACC/ON Door lock: UNLOCK (with Intelligent Key or driver side door request switch operation) Key ID Key switch: Insert/Pull out Intelligent Key Starter: CRANKING/OTHER Handle position : LHD
Combination meter / ABS	Transmit the vehicle speed signal to the driver seat control unit via CAN communication.
AV control unit	The setting change of auto drive positioner system can be performed on the display.
TCM	Transmit the shift position signal (P range) to the driver seat control unit via CAN communication.

INPUT PARTS

Switches

Item	Function
Key slot	The key switch is installed to detect the key inserted/removed status.
Front door switch (driver side)	Detect front door (driver side) open/close status.
CVT shift selector (detention switch)	Detect the P range position of A/T selector lever.
Set switch	The registration and system setting can be performed with its operation.
Memory switch 1/2	The registration and operation can be performed with its operation.
Power seat switch	The following switch is installed. <ul style="list-style-type: none"> Reclining switch Lifting switch (front) Lifting switch (rear) Sliding switch The specific parts can be operated with the operation of each switch.

AUTOMATIC DRIVE POSITIONER SYSTEM

< SYSTEM DESCRIPTION >

Item	Function
Tilt & telescopic switch	The following switch is installed. <ul style="list-style-type: none"> • Tilt switch • Telescopic switch The specific parts can be operated with the operation of each switch.
Door mirror remote control switch	The following switch is installed. <ul style="list-style-type: none"> • Mirror switch • Changeover switch The specific parts can be operated with the operation of each switch.

Sensors

Item	Function
Door mirror sensor (driver side/passenger side)	Detect the up/down and left/right position of outside mirror face.
Tilt and telescopic sensor	Detect the up/down and left/right position of steering column.
Lifting sensor (front)	Detect the up/down position of seat lifting (front).
Lifting sensor (rear)	Detect the up/down position of seat lifting (rear).
Reclining sensor	Detect the tilt of seatback.
Sliding sensor	Detect the front/rear position of seat.

OUTPUT PARTS

Item	Function
Door mirror motor (driver side/passenger side)	Move the outside mirror face upward/downward and leftward/rightward.
Tilt and telescopic motor	Move the steering column upward/downward and frontward/rearward.
Lifting motor (front)	Move the seat lifting (front) upward/downward.
Lifting motor (rear)	Move the seat lifting (rear) upward/downward.
Reclining motor	Tilt and raise up the seatback.
Sliding motor	Slide the seat frontward/rearward.
Memory indicator	Illuminates or flashes according to the registration/operation status.

ENTRY ASSIST FUNCTION

A
B
C
D
E
F
G
H
I
K
L
M
N
O
P

ADP

AUTOMATIC DRIVE POSITIONER SYSTEM

< SYSTEM DESCRIPTION >

ENTRY ASSIST FUNCTION : System Diagram

INFOID:000000006257995

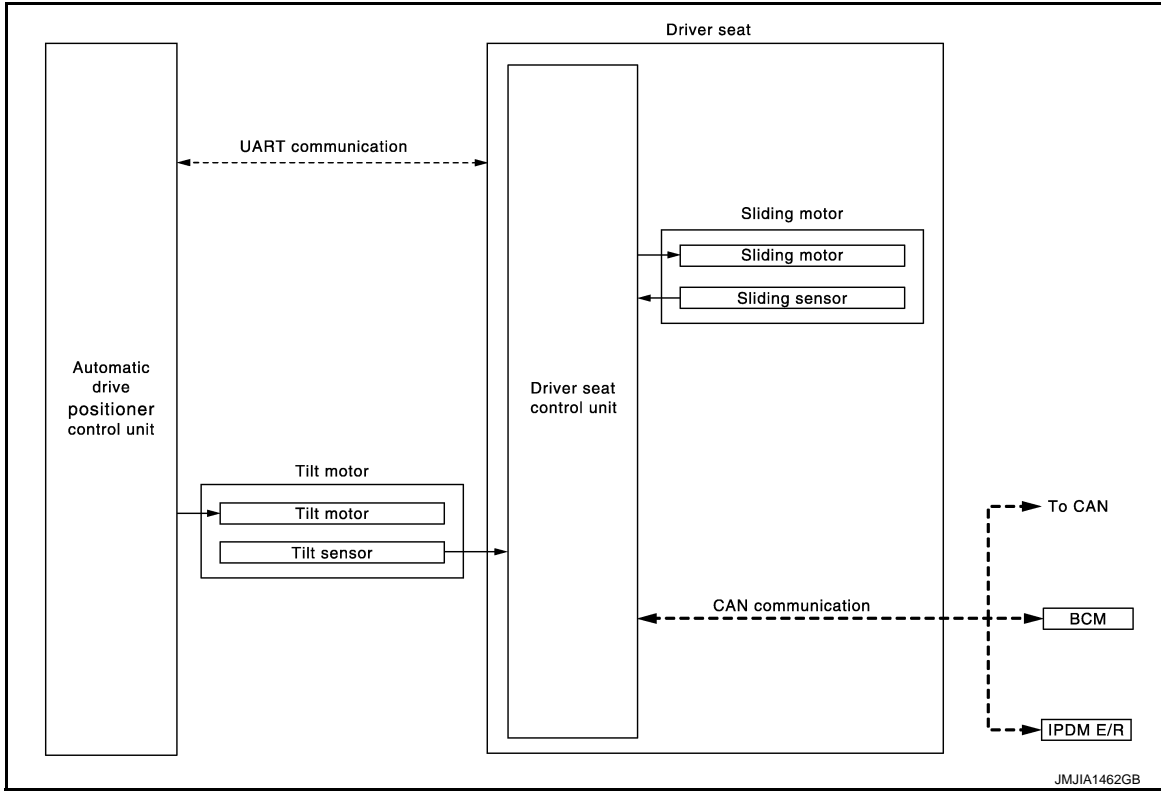

ENTRY ASSIST FUNCTION : System Description

INFOID:000000006257996

OUTLINE

The seat is in the exiting position when following condition is satisfied, the seat returns from exiting position to the previous driving position.

NOTE:

- This function is set to OFF before delivery (initial setting).
- Further information for the system setting procedure. Refer to [ADP-9, "SYSTEM INITIALIZATION : Description"](#).

OPERATION PROCEDURE

1. Turn the ignition switch ACC.
2. Driver seat and steering column will return from the exiting position to entry position.

OPERATION CONDITION

Satisfy all of the following items. The entry assist function is not performed if these items are not satisfied.

Item	Request status
Seat, steering column	The vehicle is not moved after performing the exit assist function.
Switch inputs <ul style="list-style-type: none"> • Power seat switch • Tilt & telescopic switch • Door mirror control switch • Set switch • Memory switch 	OFF (Not operated)

DETAIL FLOW

AUTOMATIC DRIVE POSITIONER SYSTEM

< SYSTEM DESCRIPTION >

Order	Input	Output	Control unit condition
1	Ignition switch	—	Driver seat control unit receives the signals of [ignition switch signal] from BCM via CAN communication.
2	—	Motors (Sliding, tilt)	Driver side control unit operates the sliding motor when the operating conditions are satisfied and requests the operations of tilt motor to automatic drive positioner control unit via UART communication. The automatic drive positioner operates each motor.
	Sensors (Sliding, tilt)	—	Each sensor monitors the operating positions of seat and steering, and then stops the operation of each motor when each part reaches the recorded address.

A

B

C

D

E

F

G

H

I

ADP

K

L

M

N

O

P

AUTOMATIC DRIVE POSITIONER SYSTEM

< SYSTEM DESCRIPTION >

ENTRY ASSIST FUNCTION : Component Parts Location

INFOID:000000006257997

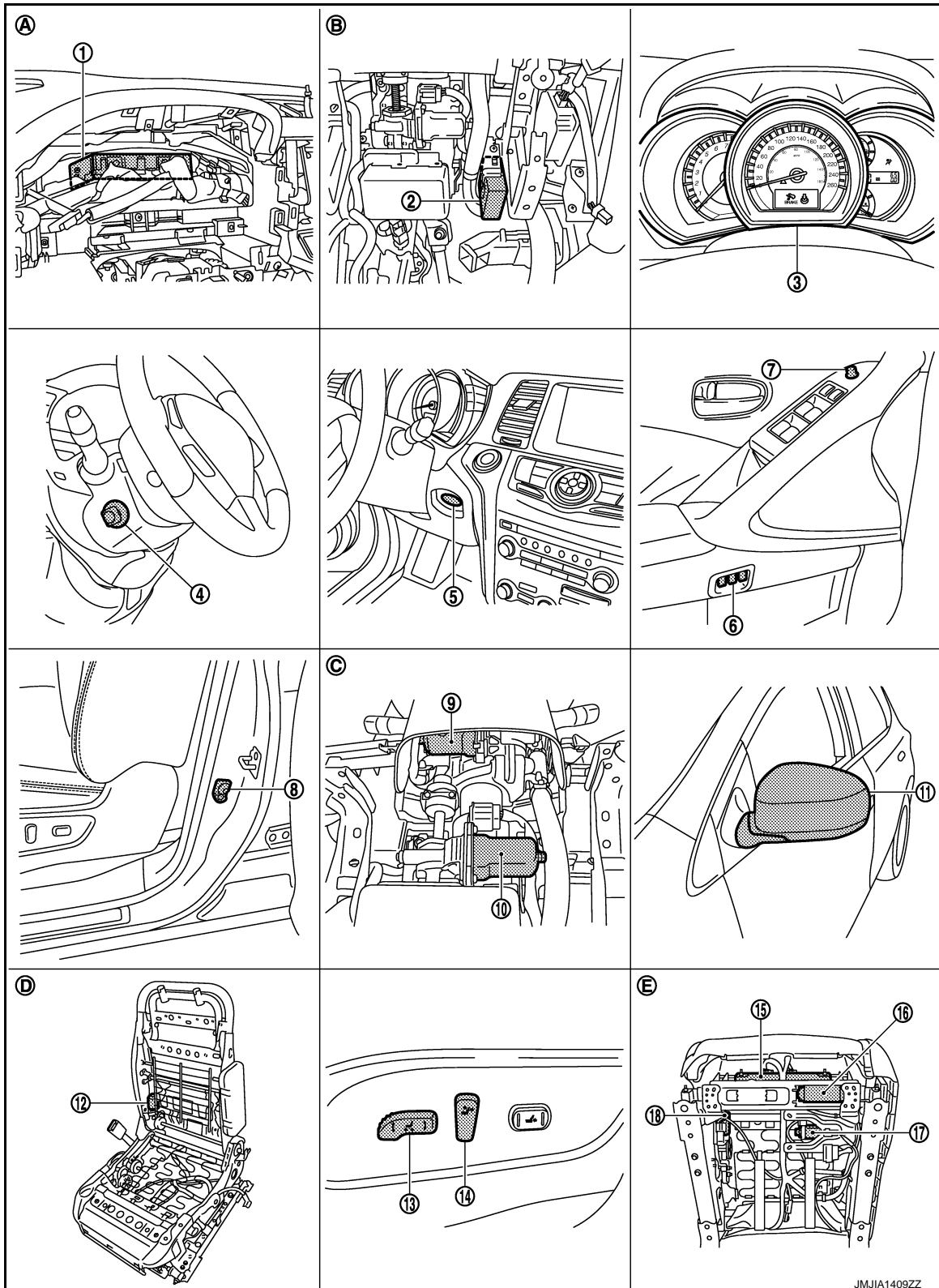

JMJIA1409ZZ

- | | | |
|--|--|---------------------------|
| 1. BCM M118, M119, M122, M123 | 2. Automatic drive positioner control unit M75, M104 | 3. Combination meter |
| 4. Tilt & telescopic switch M102 | 5. Key slot M99 | 6. Seat memory switch D13 |
| 7. Door mirror remote control switch D14 | 8. Front door switch (driver side) B34 | 9. Tilt motor M116 |

AUTOMATIC DRIVE POSITIONER SYSTEM

< SYSTEM DESCRIPTION >

- | | | |
|---|--|--|
| 10. Telescopic motor M117 | 11. Door mirror (driver side) D3 | 12. Reclining motor B461 |
| 13. Sliding, Lifting switch
(Power seat switch B459) | 14. Reclining switch
(Power seat switch B459) | 15. Driver seat control unit B451,B452 |
| 16. Sliding motor B461 | 17. Lifting motor (front) B455 | 18. Lifting motor (rear) B456 |
| A. Behind the combination meter | B. View with instrument driver lower panel removed | C. View with instrument driver lower panel removed |
| D. View with seat cushion and seatback pad removed | E. Backside of the seat cushion | |

ENTRY ASSIST FUNCTION : Component Description

INFOID:000000006854208

CONTROL UNITS

Item	Function
Driver seat control unit	<ul style="list-style-type: none"> Main units of automatic drive positioner system It is connected to the CAN. It communicates with the automatic drive positioner control via UART communication.
Automatic drive positioner control unit	<ul style="list-style-type: none"> It communicates with the driver seat control unit via UART communication. Perform various controls with the instructions of driver seat control unit. Perform the controls of the tilt & telescopic, door mirror switch.
BCM	Transmit the following status to the driver seat control unit via CAN communication. <ul style="list-style-type: none"> Driver door: OPEN/CLOSE Ignition switch position: ACC/ON Door lock: UNLOCK (with Intelligent Key or driver side door request switch operation) Key ID Key switch: Insert/Pull out Intelligent Key Starter: CRANKING/OTHER Handle position : LHD
Combination meter / ABS	Transmit the vehicle speed signal to the driver seat control unit via CAN communication.
AV control unit	The setting change of auto drive positioner system can be performed on the display.
TCM	Transmit the shift position signal (P range) to the driver seat control unit via CAN communication.

INPUT PARTS

Switches

Item	Function
Key slot	The key switch is installed to detect the key inserted/removed status.
Front door switch (driver side)	Detect front door (driver side) open/close status.
CVT shift selector (detention switch)	Detect the P range position of A/T selector lever.
Set switch	The registration and system setting can be performed with its operation.
Memory switch 1/2	The registration and operation can be performed with its operation.
Power seat switch	The following switch is installed. <ul style="list-style-type: none"> Reclining switch Lifting switch (front) Lifting switch (rear) Sliding switch The specific parts can be operated with the operation of each switch.

AUTOMATIC DRIVE POSITIONER SYSTEM

< SYSTEM DESCRIPTION >

Item	Function
Tilt & telescopic switch	The following switch is installed. <ul style="list-style-type: none"> • Tilt switch • Telescopic switch The specific parts can be operated with the operation of each switch.
Door mirror remote control switch	The following switch is installed. <ul style="list-style-type: none"> • Mirror switch • Changeover switch The specific parts can be operated with the operation of each switch.

Sensors

Item	Function
Door mirror sensor (driver side/passenger side)	Detect the up/down and left/right position of outside mirror face.
Tilt and telescopic sensor	Detect the up/down and left/right position of steering column.
Lifting sensor (front)	Detect the up/down position of seat lifting (front).
Lifting sensor (rear)	Detect the up/down position of seat lifting (rear).
Reclining sensor	Detect the tilt of seatback.
Sliding sensor	Detect the front/rear position of seat.

OUTPUT PARTS

Item	Function
Door mirror motor (driver side/passenger side)	Move the outside mirror face upward/downward and leftward/rightward.
Tilt and telescopic motor	Move the steering column upward/downward and frontward/rearward.
Lifting motor (front)	Move the seat lifting (front) upward/downward.
Lifting motor (rear)	Move the seat lifting (rear) upward/downward.
Reclining motor	Tilt and raise up the seatback.
Sliding motor	Slide the seat frontward/rearward.
Memory indicator	Illuminates or flashes according to the registration/operation status.

INTELLIGENT KEY INTERLOCK FUNCTION

AUTOMATIC DRIVE POSITIONER SYSTEM

< SYSTEM DESCRIPTION >

INTELLIGENT KEY INTERLOCK FUNCTION : System Diagram

INFOID:000000006257999

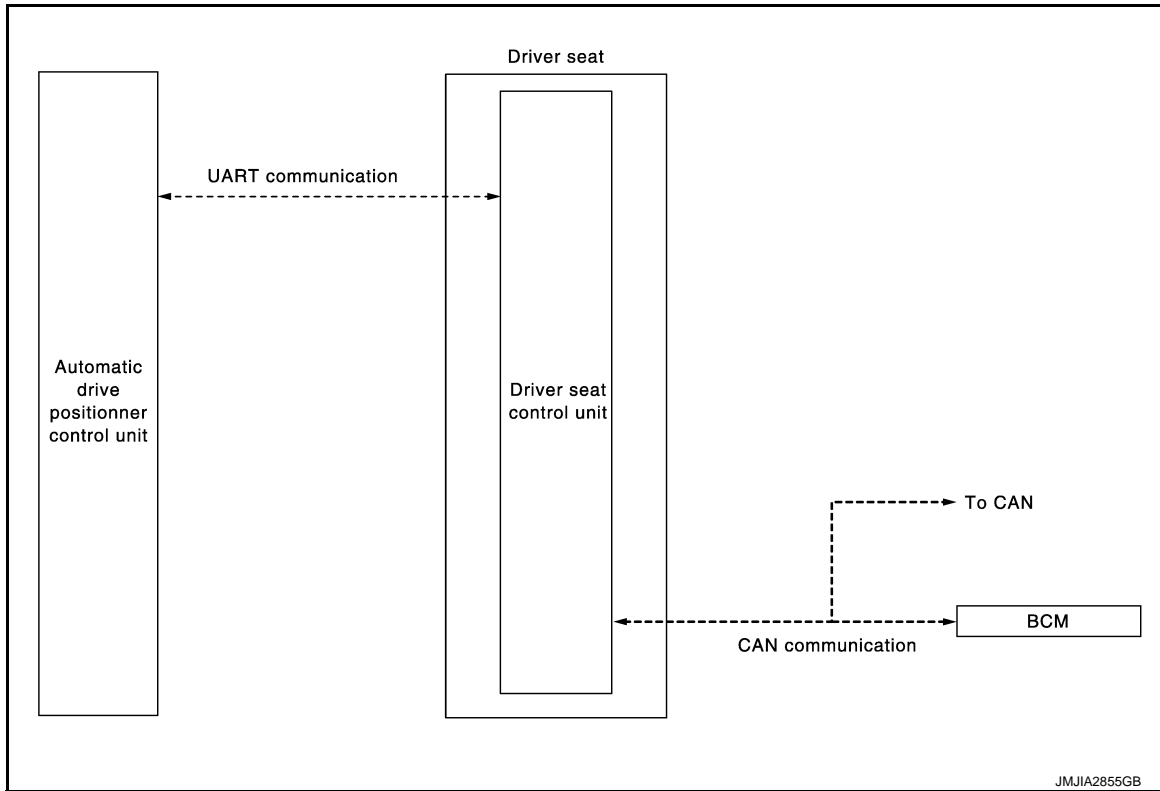

JMJIA2855GB

INTELLIGENT KEY INTERLOCK FUNCTION : System Description

INFOID:000000006258000

OUTLINE

When unlocking doors by using Intelligent Key or door request switch (driver side), seat slide and steering tilt move directly to the exit assist function.

Other loads move to the exit assist function after performing memory function.

After performs the entry assist function.

OPERATION PROCEDURE

1. Unlock doors by using Intelligent Key or door request switch (driver side) .
2. The system performs exit assist operation and memory operation.

NOTE:

Further information for Intelligent Key interlock function. Refer to [ADP-9, "MEMORY STORING : Description"](#).

OPERATION CONDITION

Satisfy all of the following items. The Intelligent Key interlock function is not performed if these items are not satisfied.

Item	Request status
Ignition position	OFF
Switch inputs <ul style="list-style-type: none"> • Power seat switch • Tilt & telescopic switch • Door mirror control switch • Set switch • Memory switch 	OFF (Not operated)
A/T selector lever	P position

DETAIL FLOW

A
B
C
D
E
F
G
H
I

ADP

K
L
M
N
O
P

AUTOMATIC DRIVE POSITIONER SYSTEM

< SYSTEM DESCRIPTION >

Order	Input	Output	Control unit condition
1	<ul style="list-style-type: none">• Door unlock signal (CAN)• Key ID signal (CAN)	—	Driver seat control unit receives the door unlock signal and the key ID signal from BCM when unlocking the door with Intelligent Key or driver side door request switch.
2	—	—	Driver seat control unit performs the seat slide and steering tilt move directly to the exit assist function. Other loads move to the exit assist function after performing memory function.
3	—	—	Driver seat control unit performs the entry assist function.

AUTOMATIC DRIVE POSITIONER SYSTEM

< SYSTEM DESCRIPTION >

INTELLIGENT KEY INTERLOCK FUNCTION : Component Parts Location INFOID:000000006258001

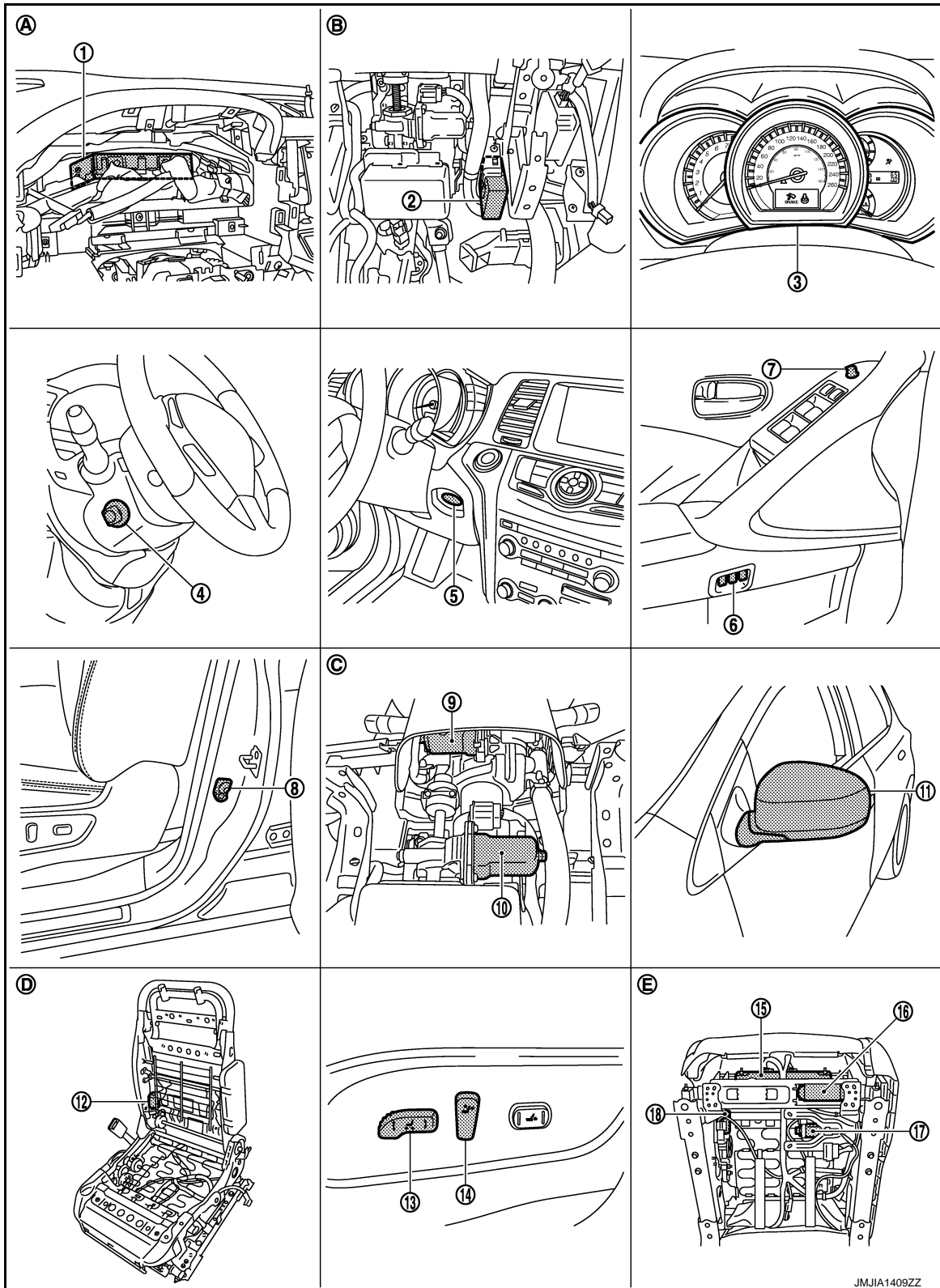

- | | | |
|--|--|---------------------------|
| 1. BCM M118, M119, M122, M123 | 2. Automatic drive positioner control unit M75, M104 | 3. Combination meter |
| 4. Tilt & telescopic switch M102 | 5. Key slot M99 | 6. Seat memory switch D13 |
| 7. Door mirror remote control switch D14 | 8. Front door switch (driver side) B34 | 9. Tilt motor M116 |

JMJIA1409ZZ

AUTOMATIC DRIVE POSITIONER SYSTEM

< SYSTEM DESCRIPTION >

- | | | |
|---|---|---|
| 10. Telescopic motor M117 | 11. Door mirror (driver side) D3 | 12. Reclining motor B461 |
| 13. Sliding, Lifting switch
(Power seat switch B459) | 14. Reclining switch
(Power seat switch B459) | 15. Driver seat control unit B451,B452 |
| 16. Sliding motor B461 | 17. Lifting motor (front) B455 | 18. Lifting motor (rear) B456 |
| A. Behind the combination meter | B. View with instrument driver lower
panel removed | C. View with instrument driver lower
panel removed |
| D. View with seat cushion and seatback
pad removed | E. Backside of the seat cushion | |

INTELLIGENT KEY INTERLOCK FUNCTION : Component Description

INFOID:000000006258002

CONTROL UNITS

Item	Function
Driver seat control unit	It performs memory function and entry/exit assist function after receiving the door unlock signal from BCM.
Automatic drive positioner control unit	Operates the steering column and door mirror with the instructions from the driver seat control unit.
BCM	Recognizes the following status and transmits it to the driver seat control unit via CAN communication. <ul style="list-style-type: none"> • Door lock: UNLOCK (with Intelligent Key or driver side door request switch) • Key ID signal • Ignition switch signal

DIAGNOSIS SYSTEM (DRIVER SEAT CONTROL UNIT)

< SYSTEM DESCRIPTION >

DIAGNOSIS SYSTEM (DRIVER SEAT CONTROL UNIT)

Diagnosis Description

INFOID:000000006258003

The auto drive positioner system can be checked and diagnosed for component operation with CONSULT-III.

DIAGNOSTIC MODE

Diagnostic mode [AUTO DRIVE POS.]	Description
WORK SUPPORT	Changes the setting of each function.
SELF-DIAG RESULTS	Performs self-diagnosis for the auto drive positioner system and displays the results.
DATA MONITOR	Displays input signals transmitted from various switches and sensors to driver seat control unit in real time.
CAN DIAG SUPPORT MNTR	The result of transmit/receive diagnosis of CAN communication can be read.
ACTIVE TEST	Drive each output device.
ECU IDENTIFICATION	Displays part numbers of driver seat control unit parts.

CONSULT-III Function

INFOID:000000006258004

SELF-DIAGNOSIS RESULTS

Refer to [ADP-136, "DTC Index"](#).

DATA MONITOR

Monitor Item	Unit	Main Signals	Selection From Menu	Contents
SET SW	"ON/OFF"	×	×	ON/OFF status judged from the setting switch signal.
MEMORY SW 1	"ON/OFF"	×	×	ON/OFF status judged from the seat memory switch 1 signal.
MEMORY SW 2	"ON/OFF"	×	×	ON/OFF status judged from the seat memory switch 2 signal.
SLIDE SW-FR	"ON/OFF"	×	×	ON/OFF status judged from the sliding switch (forward) signal.
SLIDE SW-RR	"ON/OFF"	×	×	ON/OFF status judged from the sliding switch (backward) signal.
RECLN SW-FR	"ON/OFF"	×	×	ON/OFF status judged from the reclining switch (forward) signal.
RECLN SW-RR	"ON/OFF"	×	×	ON/OFF status judged from the reclining switch (backward) signal.
LIFT FR SW-UP	"ON/OFF"	×	×	ON/OFF status judged from the lifting switch front (up) signal.
LIFT FR SW-DN	"ON/OFF"	×	×	ON/OFF status judged from the lifting switch front (down) signal.
LIFT RR SW-UP	"ON/OFF"	×	×	ON/OFF status judged from the lifting switch rear (up) signal.
LIFT RR SW-DN	"ON/OFF"	×	×	ON/OFF status judged from the lifting switch rear (down) signal.
MIR CON SW-UP	"ON/OFF"	×	×	ON/OFF status judged from the mirror switch (up) signal.
MIR CON SW-DN	"ON/OFF"	×	×	ON/OFF status judged from the mirror switch (down) signal.
MIR CON SW-RH	"ON/OFF"	×	×	ON/OFF status judged from the door mirror remote control switch (passenger side) signal.
MIR CON SW-LH	"ON/OFF"	×	×	ON/OFF status judged from the door mirror remote control switch (driver side) signal.

DIAGNOSIS SYSTEM (DRIVER SEAT CONTROL UNIT)

< SYSTEM DESCRIPTION >

Monitor Item	Unit	Main Signals	Selection From Menu	Contents
MIR CHNG SW-R	"ON/OFF"	×	×	ON/OFF status judged from the door mirror remote control switch (switching to right) signal.
MIR CHNG SW-L	"ON/OFF"	×	×	ON/OFF status judged from the door mirror remote control switch (switching to left) signal.
TILT SW-UP	"ON/OFF"	×	×	ON/OFF status judged from the tilt switch (up) signal.
TILT SW-DOWN	"ON/OFF"	×	×	ON/OFF status judged from the tilt switch (down) signal.
TELESCO SW-FR	"ON/OFF"	×	×	ON/OFF status judged from the telescoping switch (forward) signal.
TELESCO SW-RR	"ON/OFF"	×	×	ON/OFF status judged from the telescoping switch (backward) signal.
DETENT SW	"ON/OFF"	×	×	The selector lever position "OFF (P position) / ON (other than P position)" judged from the detention switch signal.
STARTER SW	"ON/OFF"	×	×	Ignition key switch ON (START, ON) /OFF (ACC, OFF) status judged from the ignition switch signal.
SLIDE PULSE	—	—	×	Value (32768) when battery connections are standard. If it moves backward, the value increases. If it moves forward, the value decreases.
RECLN PULSE	—	—	×	Value (32768) when battery connections are standard. If it moves backward, the value increases. If it moves forward, the value decreases.
LIFT FR PULSE	—	—	×	Value (32768) when battery connections are standard. If it moves DOWN, the value increases. If it moves UP, the value decreases.
LIFT RR PULSE	—	—	×	Value (32768) when battery connections are standard. If it moves DOWN, the value increases. If it moves UP, the value decreases.
MIR/SEN RH U-D	"V"	—	×	Voltage input from door mirror sensor (passenger side) up/down is displayed.
MIR/SEN RH R-L	"V"	—	×	Voltage input from door mirror sensor (passenger side) left/right is displayed.
MIR/SEN LH U-D	"V"	—	×	Voltage input from door mirror sensor (driver side) up/down is displayed.
MIR/SEN LH R-L	"V"	—	×	Voltage input from door mirror sensor (driver side) left/right is displayed.
TILT PULSE	—	—	×	Value (32768) when battery connections are standard. If it moves DOWN, the value increases. If it moves UP, the value decreases.
TELESCO PULSE	—	—	×	Value (32768) when battery connections are standard. If it moves backward, the value increases. If it moves forward, the value decreases.
VEHICLE SPEED	—	×	×	Display the vehicle speed signal received from combination meter by numerical value [km/h].
P RANG SW CAN	"ON/OFF"	×	×	ON/OFF status judged from the P range switch signal.
R RANGE (CAN)	"ON/OFF"	×	×	ON/OFF status judged from the R range switch signal.
DOOR SW-FL	"ON/OFF"	×	×	ON/OFF status judged from the door switch (front driver side) signal.
DOOR SW-FR	"ON/OFF"	×	×	ON/OFF status judged from the door switch (front passenger side) signal.
IGN ON SW	"ON/OFF"	×	×	ON/OFF status judged from the ignition switch signal.
ACC ON SW	"ON/OFF"	×	×	ON/OFF status judged from the ACC switch signal.
KEY ON SW	"ON/OFF"	×	×	ON/OFF status judged from the key on switch signal.

DIAGNOSIS SYSTEM (DRIVER SEAT CONTROL UNIT)

< SYSTEM DESCRIPTION >

Monitor Item	Unit	Main Signals	Selection From Menu	Contents
KEYLESS ID	—	×	×	Key ID status judged from the key ID signal.
KYLS DR UNLK	“ON/OFF”	×	×	ON/OFF status judged from the driver side door unlock actuator output switch signal.
VHCL SPEED (ABS)	“ON/OFF”	×	×	ON/OFF status judged from vehicle speed signal.
HANDLE	“RHD/LHD”	×	×	RHD/LHD status judged from handle position signal.
TRANSMISSION	“AT or CVT/MT”	×	×	AT or CVT/MT status judged from transmission.
STEERING STATUS	NOTE: This item is displayed, but cannot monitored			

ACTIVE TEST

CAUTION:

When driving vehicle, do not perform active test.

Test item	Description
SEAT SLIDE	Activates/deactivates the sliding motor.
SEAT RECLINING	Activates/deactivates the reclining motor.
SEAT LIFTER FR	Activates/deactivates the lifting motor (front).
SEAT LIFTER RR	Activates/deactivates the lifting motor (rear).
TILT MOTOR	Activates/deactivates the tilt motor.
TELESCO MOTOR	Activates/deactivates the telescopic motor.
MIRROR MOTOR RH	Activates/deactivates the mirror motor (passenger side).
MIRROR MOTOR LH	Activates/deactivates the mirror motor (driver side).
MEMORY SW INDCTR	Turns ON/OFF the memory indicator.

WORK SUPPORT

Work item	Content	Item
SEAT SLIDE VOLUME SET	The amount of seat sliding for entry/exit assist can be selected from 3 items.	40 mm
		80 mm
		150 mm
EXIT TILT SETTING	Entry/exit assist (steering column) can be selected: ON (operated) – OFF (not operated)	ON
		OFF
EXIT SEAT SLIDE SETTING	Entry/exit assist (seat) can be selected: ON (operated) – OFF (not operated)	ON
		OFF

U1000 CAN COMM CIRCUIT

< DTC/CIRCUIT DIAGNOSIS >

DTC/CIRCUIT DIAGNOSIS

U1000 CAN COMM CIRCUIT

Description

INFOID:000000006258005

CAN (Controller Area Network) is a serial communication line for real time applications. It is an on-vehicle multiplex communication line with high data communication speed and excellent error detection ability. Modern vehicle is equipped with many electronic control unit, and each control unit shares information and links with other control units during operation (not independent). In CAN communication, control units are connected with 2 communication lines (CAN H-line, CAN L-line) allowing a high rate of information transmission with less wiring. Each control unit transmits/receives data but selectively reads required data only.

DTC Logic

INFOID:000000006258006

DTC DETECTION LOGIC

DTC No.	Trouble diagnosis name	DTC detecting condition	Possible cause
U1000	CAN COMM CIRCUIT	<ul style="list-style-type: none">• Driver seat control unit cannot communicate to other control units.• Driver seat control unit cannot communicate for more than the specified time.	<ul style="list-style-type: none">• Harness or connectors (CAN communication line is open or shorted)

DTC CONFIRMATION PROCEDURE

1.STEP 1

Turn ignition switch ON and wait at least 3 seconds.

>> GO TO 2.

2.STEP 2

Check "Self diagnostic result" with CONSULT-III.

Is the DTC detected?

- YES >> Perform diagnosis procedure. Refer to [ADP-44, "Diagnosis Procedure"](#).
NO >> INSPECTION END

Diagnosis Procedure

INFOID:000000006258007

Refer to [LAN-15, "Trouble Diagnosis Flow Chart"](#).

Special Repair Requirement

INFOID:000000006258008

Refer to [ADP-9, "SYSTEM INITIALIZATION : Description"](#).

U1010 CONTROL UNIT (CAN)

< DTC/CIRCUIT DIAGNOSIS >

U1010 CONTROL UNIT (CAN)

Description

INFOID:000000006258009

CAN (Controller Area Network) is a serial communication line for real time applications. It is an on-vehicle multiplex communication line with high data communication speed and excellent error detection ability. Modern vehicle is equipped with many electronic control unit, and each control unit shares information and links with other control units during operation (not independent). In CAN communication, control units are connected with 2 communication lines (CAN-H line, CAN-L line) allowing a high rate of information transmission with less wiring. Each control unit transmits/receives data but selectively reads required data only. CAN Communication Signal Chart, refer to [LAN-25, "CAN Communication Signal Chart"](#).

DTC Logic

INFOID:000000006258010

DTC DETECTION LOGIC

DTC No.	Trouble diagnosis name	DTC detecting condition	Possible cause
U1010	CONTROL UNIT (CAN)	When detecting error during the initial diagnosis of CAN controller of driver seat control unit.	<ul style="list-style-type: none">• Driver seat control unit

Diagnosis Procedure

INFOID:000000006258011

1. REPLACE DRIVER SEAT CONTROL UNIT

When DTC [U1010] is detected, replace driver seat control unit.

>> Replace driver seat control unit. Refer to [ADP-201, "Removal and Installation"](#).

A
B
C
D
E
F
G
H
I
K
L
M
N
O
P

ADP

B2130 EEPROM

< DTC/CIRCUIT DIAGNOSIS >

B2130 EEPROM

DTC Logic

INFOID:000000006258012

DTC DETECTION LOGIC

DTC No.	Trouble diagnosis name	DTC detecting condition	Possible cause
B2130	EEPROM	Driver seat control unit detected CPU malfunction.	• Driver seat control unit

DTC CONFIRMATION PROCEDURE

1.STEP 1

Turn ignition switch ON.

>> GO TO 2.

2.STEP 2

Check "Self diagnostic result" with CONSULT-III.

Is the DTC detected?

- YES >> Perform diagnosis procedure. Refer to [ADP-46, "Diagnosis Procedure"](#).
NO >> INSPECTION END

Diagnosis Procedure

INFOID:000000006258013

1.PERFORM DTC CONFIRMATION PROCEDURE

1. Turn ignition switch ON.
2. Check "Self diagnostic result" with CONSULT-III.
3. Erase the DTC.
4. Perform DTC confirmation procedure. Refer to [ADP-46, "DTC Logic"](#).

Is the DTC displayed again?

- YES >> GO TO 2.
NO >> Check intermittent incident. Refer to [GI-44, "Intermittent Incident"](#).

2.REPLACE DRIVER SEAT CONTROL UNIT

Replace driver seat control unit. Refer to [ADP-201, "Removal and Installation"](#).

>> INSPECTION END

B2112 SLIDING MOTOR

< DTC/CIRCUIT DIAGNOSIS >

B2112 SLIDING MOTOR

Description

INFOID:000000006258014

- The sliding motor is installed to the seat cushion frame.
- The sliding motor is activated with the driver seat control unit.
- Slides the seat forward/ rearward by changing the rotation direction of sliding motor.

DTC Logic

INFOID:000000006258015

DTC DETECTION LOGIC

DTC No.	Trouble diagnosis name	DTC detecting condition	Possible cause
B2112	SEAT SLIDE	The driver seat control unit detects the output of sliding motor output terminal for 0.1 second or more even if the sliding switch is not input.	<ul style="list-style-type: none">• Driver seat control unit• Slide motor harness is shorted

DTC CONFIRMATION PROCEDURE

1.STEP 1

Turn ignition switch ON.

>> GO TO 2.

2.STEP 2

Check "Self diagnostic result" with CONSULT-III.

Is the DTC detected?

- YES >> Perform diagnosis procedure. Refer to [ADP-47, "Diagnosis Procedure"](#).
NO >> INSPECTION END

Diagnosis Procedure

INFOID:000000006258016

ADP

1.PERFORM DTC CONFIRMATION PROCEDURE

1. Turn ignition switch ON.
2. Check "Self diagnostic result" with CONSULT-III.
3. Erase the DTC.
4. Perform DTC confirmation procedure. Refer to [ADP-47, "DTC Logic"](#).

Is the DTC displayed again?

- YES >> GO TO 2.
NO >> Check intermittent incident. Refer to [GI-44, "Intermittent Incident"](#).

2.CHECK SLIDING MOTOR CIRCUIT (POWER SHORT)

1. Turn ignition switch OFF.
2. Disconnect sliding motor and driver seat control unit connector.
3. Check voltage between sliding motor harness connector and ground.

(+)		(-)	Voltage (V) (Approx.)
Sliding motor			
Connector	Terminals	Ground	0
B461	50		
	51		

Is the inspection result normal?

- YES >> GO TO 3.
NO >> Repair or replace harness or connector.

3.CHECK DRIVER SEAT CONTROL UNIT OUTPUT SIGNAL

1. Connect driver seat control unit connector.

B2112 SLIDING MOTOR

< DTC/CIRCUIT DIAGNOSIS >

2. Check voltage between driver seat control unit harness connector and ground.

(+)		(-)	Voltage (V) (Approx.)
Driver seat control unit			
Connector	Terminals		
B451	3	Ground	0
	4		

Is the inspection result normal?

YES >> GO TO 4.

NO >> Replace driver seat control unit. Refer to [ADP-201, "Removal and Installation"](#)

4. CHECK INTERMITTENT INCIDENT

Refer to [GI-44, "Intermittent Incident"](#).

>> INSPECTION END

B2113 RECLINING MOTOR

< DTC/CIRCUIT DIAGNOSIS >

B2113 RECLINING MOTOR

Description

INFOID:000000006258017

- The reclining motor is installed to the seatback frame.
- The reclining motor is activated with the driver seat control unit.
- Tilts the seatback frontward/rearward by changing the rotation direction of reclining motor.

DTC Logic

INFOID:000000006258018

DTC DETECTION LOGIC

DTC No.	Trouble diagnosis name	DTC detecting condition	Possible cause
B2113	SEAT RECLINING	The driver seat control unit detects the output of reclining motor output terminal for 0.1 second or more even if the reclining switch is not input.	<ul style="list-style-type: none">• Driver seat control unit• Reclining motor harness is shorted

DTC CONFIRMATION PROCEDURE

1.STEP 1

Turn ignition switch ON.

>> GO TO 2.

2.STEP 2

Check "Self diagnostic result" with CONSULT-III.

Is the DTC detected?

- YES >> Perform diagnosis procedure. Refer to [ADP-49, "Diagnosis Procedure"](#).
NO >> INSPECTION END

Diagnosis Procedure

INFOID:000000006258019

ADP

1.PERFORM DTC CONFIRMATION PROCEDURE

1. Turn ignition switch ON.
2. Check "Self diagnostic result" with CONSULT-III.
3. Erase the DTC.
4. Perform DTC confirmation procedure. Refer to [ADP-49, "DTC Logic"](#).

Is the DTC displayed again?

- YES >> GO TO 2.
NO >> Check intermittent incident. Refer to [GI-44, "Intermittent Incident"](#).

2.CHECK RECLINING MOTOR CIRCUIT (POWER SHORT)

1. Turn ignition switch OFF.
2. Disconnect reclining motor and driver seat control unit connector.
3. Check voltage between reclining motor harness connector and ground.

(+)		(-)	Voltage (V) (Approx.)
Reclining motor			
Connector	Terminals	Ground	0
B454	52		
	53		

Is the inspection result normal?

- YES >> GO TO 3.
NO >> Repair or replace harness or connector.

3.CHECK DRIVER SEAT CONTROL UNIT OUTPUT SIGNAL

1. Connect driver seat control unit connector.

B2113 RECLINING MOTOR

< DTC/CIRCUIT DIAGNOSIS >

2. Check voltage between driver seat control unit harness connector and ground.

(+)		(-)	Voltage (V) (Approx.)
Driver seat control unit			
Connector	Terminals		
B451	5	Ground	0
	6		

Is the inspection result normal?

YES >> GO TO 4.

NO >> Replace driver seat control unit. Refer to [ADP-201, "Removal and Installation"](#).

4. CHECK INTERMITTENT INCIDENT

Refer to [GI-44, "Intermittent Incident"](#).

>> INSPECTION END

B2116 TILT MOTOR

< DTC/CIRCUIT DIAGNOSIS >

B2116 TILT MOTOR

Description

INFOID:000000006258020

- The tilt motor is installed to the steering column assembly.
- The tilt motor is activated with the automatic drive positioner control unit.
- Tilts the steering column is tilted upward/downward by changing the rotation direction tilt motor.

DTC Logic

INFOID:000000006258021

DTC DETECTION LOGIC

DTC No.	Trouble diagnosis name	DTC detecting condition	Possible cause
B2116	STEERING TILT	The automatic drive positioner control unit detects the output of reclining motor output terminal for 0.1 second or more even if the tilt switch is not input.	<ul style="list-style-type: none">• Automatic drive positioner control unit• Tilt motor harness is shorted

DTC CONFIRMATION PROCEDURE

1.STEP 1

Turn ignition switch ON.

>> GO TO 2.

2.STEP 2

Check "Self diagnostic result" with CONSULT-III.

Is the DTC detected?

- YES >> Perform diagnosis procedure. Refer to [ADP-51, "Diagnosis Procedure"](#).
NO >> INSPECTION END

Diagnosis Procedure

INFOID:000000006258022

ADP

1.PERFORM DTC CONFIRMATION PROCEDURE

1. Turn ignition switch ON.
2. Check "Self diagnostic result" with CONSULT-III.
3. Erase the DTC.
4. Perform DTC confirmation procedure. Refer to [ADP-51, "DTC Logic"](#).

Is the DTC displayed again?

- YES >> GO TO 2.
NO >> Check intermittent incident. Refer to [GI-44, "Intermittent Incident"](#).

2.CHECK TILT MOTOR CIRCUIT (POWER SHORT)

1. Turn ignition switch OFF.
2. Disconnect automatic drive positioner control unit and tilt motor connector.
3. Check voltage between tilt motor harness connector and ground.

(+)		(-)	Voltage (V) (Approx.)
Tilt motor			
Connector	Terminals	Ground	0
M116	1		
	2		

Is the inspection result normal?

- YES >> GO TO 3.
NO >> Repair or replace harness or connector.

3.CHECK AUTOMATIC DRIVER POSITIONER CONTROL UNIT OUTPUT SIGNAL

1. Connect automatic drive positioner control unit connector.

B2116 TILT MOTOR

< DTC/CIRCUIT DIAGNOSIS >

2. Check voltage between automatic drive positioner control unit harness connector and ground.

(+)		(-)	Voltage (V) (Approx.)
Automatic drive positioner control unit			
Connector	Terminals		
M104	28	Ground	0
	29		

Is the inspection result normal?

YES >> GO TO 4.

NO >> Replace automatic drive positioner control unit. Refer to [ADP-202. "Removal and Installation"](#).

4. CHECK INTERMITTENT INCIDENT

Refer to [GI-44. "Intermittent Incident"](#).

>> INSPECTION END

B2128 UART COMMUNICATION LINE

< DTC/CIRCUIT DIAGNOSIS >

B2128 UART COMMUNICATION LINE

Description

INFOID:000000006258023

Driver seat control unit performs UART communication with the automatic drive positioner control unit using 1 communication lines. Driver seat control unit receives the operation signals of tilt & telescopic switch, door mirror remote control switch, and the position signals of door mirror sensor from the automatic drive positioner control unit and transmits the operation request signal.

DTC Logic

INFOID:000000006258024

DTC DETECTION LOGIC

DTC No.	Trouble diagnosis name	DTC detecting condition	Possible cause
B2128	UART COMM	The communication between driver seat control unit and auto drive positioner control unit is interrupted for a period of time.	<ul style="list-style-type: none"> • UART communication line (UART communication line is open or shorted) • Driver seat control unit • Automatic drive positioner control unit

DTC CONFIRMATION PROCEDURE

1.STEP 1

Turn ignition switch ON.

>> GO TO 2.

2.PROCEDURE

Check "Self diagnostic result" with CONSULT-III.

Is the DTC detected?

- YES >> Perform diagnosis procedure. Refer to [ADP-53, "Diagnosis Procedure"](#).
 NO >> INSPECTION END

Diagnosis Procedure

INFOID:000000006258025

1.PERFORM DTC CONFIRMATION PROCEDURE

1. Turn ignition switch ON.
2. Check "Self diagnostic result" with CONSULT-III.
3. Erase the DTC.
4. Perform DTC confirmation procedure. Refer to [ADP-51, "DTC Logic"](#).

Is the DTC displayed again?

- YES >> GO TO 2.
 NO >> Check intermittent incident. Refer to [GI-44, "Intermittent Incident"](#).

2.CHECK UART COMMUNICATION LINE CONTINUITY

1. Turn ignition switch OFF.
2. Disconnect driver seat control unit and automatic drive positioner control unit connector.
3. Check continuity between driver seat control unit harness connector and automatic drive positioner control unit harness connector.

Driver seat control unit		Automatic drive positioner control unit		Continuity
Connector	Terminal	Connector	Terminal	
B452	32	M75	8	Existed

4. Check continuity between driver seat control unit harness connector and ground.

B2128 UART COMMUNICATION LINE

< DTC/CIRCUIT DIAGNOSIS >

Driver seat control unit		Ground	Continuity
Connector	Terminal		
B452	32		Not existed

Is the inspection result normal?

- YES >> Check intermittent incident. Refer to [GI-44, "Intermittent Incident"](#).
NO >> Repair or replace harness or connector.

POWER SUPPLY AND GROUND CIRCUIT

< DTC/CIRCUIT DIAGNOSIS >

POWER SUPPLY AND GROUND CIRCUIT

DRIVER SEAT CONTROL UNIT

DRIVER SEAT CONTROL UNIT : Diagnosis Procedure

INFOID:000000006258026

1.CHECK POWER SUPPLY CIRCUIT

1. Turn ignition switch OFF.
2. Check voltage between driver seat control unit harness connector and ground.

(+)		(-)	Voltage (V) (Approx.)
Driver seat control unit			
Connector	Terminals	Ground	Battery voltage
B451	1		

Is the inspection result normal?

- YES >> GO TO 2.
NO >> Repair or replace harness.

2.CHECK GROUND CIRCUIT

Check continuity between the driver seat control unit harness connector and ground.

Driver seat control unit		Ground	Continuity
Connector	Terminal		
B451	2		Existed

Is the inspection result normal?

- YES >> INSPECTION END
NO >> Repair or replace harness.

DRIVER SEAT CONTROL UNIT : Special Repair Requirement

INFOID:000000006258027

ADP

1.PERFORM ADDITIONAL SERVICE

Perform additional service when removing battery negative terminal.

>> Refer to [ADP-8, "ADDITIONAL SERVICE WHEN REMOVING BATTERY NEGATIVE TERMINAL : Description"](#).

AUTOMATIC DRIVE POSITIONER CONTROL UNIT

AUTOMATIC DRIVE POSITIONER CONTROL UNIT : Diagnosis Procedure

INFOID:000000006258028

NOTE:

Do not disconnect the battery negative terminal and the driver seat control unit connector until DTC is confirmed with CONSULT-III.

1.CHECK POWER SUPPLY CIRCUIT

1. Turn ignition switch OFF.
2. Check voltage between automatic drive positioner control unit harness connector and ground.

(+)		(-)	Voltage (V) (Approx.)
Automatic drive positioner control unit			
Connector	Terminals	Ground	Battery voltage
M104	25		

Is the inspection result normal?

- YES >> GO TO 2.
NO >> Repair or replace harness.

POWER SUPPLY AND GROUND CIRCUIT

< DTC/CIRCUIT DIAGNOSIS >

2.CHECK GROUND CIRCUIT

Check continuity between the automatic drive positioner control unit harness connector and ground.

Automatic drive positioner control unit		Ground	Continuity
Connector	Terminal		
M104	30		Existed

Is the inspection result normal?

YES >> Automatic drive positioner control unit power supply and ground circuit are OK.

NO >> Repair or replace harness.

AUTOMATIC DRIVE POSITIONER CONTROL UNIT : Special Repair Requirement

INFOID:000000006258029

1.PERFORM ADDITIONAL SERVICE

Perform additional service when removing battery negative terminal.

>> Refer to [ADP-8. "ADDITIONAL SERVICE WHEN REMOVING BATTERY NEGATIVE TERMINAL : Description"](#).

SLIDING SWITCH

< DTC/CIRCUIT DIAGNOSIS >

SLIDING SWITCH

Description

INFOID:000000006258030

Sliding switch is equipped to the power seat switch on the seat cushion side surface. The operation signal is inputted to the driver seat control unit when the sliding switch is operated.

Component Function Check

INFOID:000000006258031

1. CHECK FUNCTION

1. Select "SLIDE SW-FR", "SLIDE SW-RR" in "Data monitor" mode with CONSULT-III.
2. Check sliding switch signal under the following conditions.

Monitor item	Condition		Status
SLIDE SW-FR	Sliding switch (forward)	Operate	ON
		Release	OFF
SLIDE SW-RR	Sliding switch (backward)	Operate	ON
		Release	OFF

Is the indication normal?

YES >> INSPECTION END

NO >> Perform diagnosis procedure. Refer to [ADP-57, "Diagnosis Procedure"](#).

Diagnosis Procedure

INFOID:000000006258032

1. CHECK SLIDING SWITCH SIGNAL

1. Turn ignition switch OFF.
2. Disconnect power seat switch connector.
3. Turn ignition switch ON.
4. Check voltage between power seat switch harness connector and ground.

(+)		(-)	Voltage (V) (Approx.)
Power seat switch			
Connector	Terminals	Ground	Battery voltage
B459	11		
	12		

Is the inspection result normal?

YES >> GO TO 3.

NO >> GO TO 2.

2. CHECK SLIDING SWITCH CIRCUIT

1. Turn ignition switch OFF.
2. Disconnect driver seat control unit connector.
3. Check continuity between driver seat control unit harness connector and power seat switch harness connector.

Driver seat control unit		Power seat switch		Continuity
Connector	Terminal	Connector	Terminal	
B452	11	B459	11	Existed
	12		12	

4. Check continuity between driver seat control unit harness connector and ground.

SLIDING SWITCH

< DTC/CIRCUIT DIAGNOSIS >

Driver seat control unit		Ground	Continuity
Connector	Terminal		
B452	11		
	12		

Is the inspection result normal?

YES >> Replace driver seat control unit. Refer to [ADP-201, "Removal and Installation"](#).

NO >> Repair or replace harness or connector.

3.CHECK SLIDING SWITCH

Refer to [ADP-58, "Component Inspection"](#).

Is the inspection result normal?

YES >> GO TO 4.

NO >> Replace power seat switch. Refer to [ADP-204, "Removal and Installation"](#)

4.CHECK INTERMITTENT INCIDENT

Refer to [GI-44, "Intermittent Incident"](#).

>> INSPECTION END

Component Inspection

INFOID:000000006258033

1.CHECK SLIDING SWITCH

1. Turn ignition switch OFF.
2. Disconnect power seat switch (sliding switch) connector.
3. Check continuity between power seat switch (sliding switch) terminals.

Power seat switch (Sliding switch)		Condition		Continuity
Terminal				
35	11	Sliding switch (backward)	Operate	Existed
			Release	Not existed
	12	Sliding switch (forward)	Operate	Existed
			Release	Not existed

Is the inspection result normal?

YES >> INSPECTION END

NO >> Replace power seat switch. Refer to [ADP-204, "Removal and Installation"](#).

RECLINING SWITCH

< DTC/CIRCUIT DIAGNOSIS >

RECLINING SWITCH

Description

INFOID:000000006258034

Reclining switch is equipped to the power seat switch on the seat cushion side surface. The operation signal is inputted to the driver seat control unit when the reclining switch is operated.

Component Function Check

INFOID:000000006258035

1. CHECK FUNCTION

1. Select "RECLN SW-FR", "RECLN SW-RR" in "Data monitor" mode with CONSULT-III.
2. Check reclining switch signal under the following conditions.

Monitor item	Condition		Status
RECLINE SW-FR	Reclining switch (forward)	Operate	ON
		Release	OFF
RECLINE SW-RR	Reclining switch (backward)	Operate	ON
		Release	OFF

Is the indication normal?

YES >> INSPECTION END

NO >> Perform diagnosis procedure. Refer to [ADP-59, "Diagnosis Procedure"](#).

Diagnosis Procedure

INFOID:000000006258036

1. CHECK RECLINING SWITCH SIGNAL

1. Turn ignition switch OFF.
2. Disconnect power seat switch connector.
3. Turn ignition switch ON.
4. Check voltage between power seat switch harness connector and ground.

(+)		(-)	Voltage (V) (Approx.)
Power seat switch			
Connector	Terminals	Ground	Battery voltage
B459	13		
	14		

Is the inspection result normal?

YES >> GO TO 3.

NO >> GO TO 2.

2. CHECK RECLINING SWITCH CIRCUIT

1. Turn ignition switch OFF.
2. Disconnect driver seat control unit connector.
3. Check continuity between driver seat control unit harness connector and power seat switch harness connector.

Driver seat control unit		Power seat switch		Continuity
Connector	Terminal	Connector	Terminal	
B452	13	B459	13	Existed
	14		14	

4. Check continuity between driver seat control unit harness connector and ground.

RECLINING SWITCH

< DTC/CIRCUIT DIAGNOSIS >

Driver seat control unit		Ground	Continuity
Connector	Terminal		
B452	13		
	14		

Is the inspection result normal?

YES >> Replace driver seat control unit. Refer to [ADP-201, "Removal and Installation"](#).

NO >> Repair or replace harness or connector.

3.CHECK RECLINING SWITCH

Refer to [ADP-60, "Component Inspection"](#).

Is the inspection result normal?

YES >> GO TO 4.

NO >> Replace power seat switch. Refer to [ADP-204, "Removal and Installation"](#).

4.CHECK INTERMITTENT INCIDENT

Refer to [GI-44, "Intermittent Incident"](#).

>> INSPECTION END

Component Inspection

INFOID:000000006258037

1.CHECK RECLINING SWITCH

1. Turn ignition switch OFF.
2. Disconnect power seat switch (reclining switch) connector.
3. Check continuity between power seat switch (reclining switch) terminals.

Power seat switch (Reclining switch)		Condition		Continuity
Terminal				
35	13	Reclining switch (backward)	Operate	Existed
			Release	Not existed
	14	Reclining switch (forward)	Operate	Existed
			Release	Not existed

Is the inspection result normal?

YES >> INSPECTION END

NO >> Replace power seat switch. Refer to [ADP-204, "Removal and Installation"](#).

LIFTING SWITCH (FRONT)

< DTC/CIRCUIT DIAGNOSIS >

LIFTING SWITCH (FRONT)

Description

INFOID:000000006258038

Lifting switch (front) is equipped to the power seat switch on the seat cushion side surface. The operation signal is inputted to the driver seat control unit when the lifting switch (front) is operated.

Component Function Check

INFOID:000000006258039

1. CHECK FUNCTION

1. Select "LIFT FR SW-UP", "LIFT FR SW-DN" in "Data monitor" mode with CONSULT-III.
2. Check lifting switch (front) signal under the following conditions.

Monitor item	Condition		Status
LIFT FR SW-UP	Lifting switch front (up)	Operate	ON
		Release	OFF
LIFT FR SW-DN	Lifting switch front (down)	Operate	ON
		Release	OFF

Is the indication normal?

YES >> INSPECTION END

NO >> Perform diagnosis procedure. Refer to [ADP-61, "Diagnosis Procedure"](#).

Diagnosis Procedure

INFOID:000000006258040

1. CHECK LIFTING SWITCH (FRONT) SIGNAL

1. Turn ignition switch OFF.
2. Disconnect power seat switch connector.
3. Turn ignition switch ON.
4. Check voltage between power seat switch harness connector and ground.

(+)		(-)	Voltage (V) (Approx.)
Power seat switch			
Connector	Terminals	Ground	Battery voltage
B459	17		
	18		

Is the inspection result normal?

YES >> GO TO 3.

NO >> GO TO 2.

2. CHECK LIFTING SWITCH (FRONT) CIRCUIT

1. Turn ignition switch OFF.
2. Disconnect driver seat control unit connector.
3. Check continuity between driver seat control unit harness connector and power seat switch harness connector.

Driver seat control unit		Power seat switch		Continuity
Connector	Terminal	Connector	Terminal	
B452	17	B459	17	Existed
	18		18	

4. Check continuity between driver seat control unit harness connector and ground.

LIFTING SWITCH (FRONT)

< DTC/CIRCUIT DIAGNOSIS >

Driver seat control unit		Ground	Continuity
Connector	Terminal		
B452	17		
	18		

Is the inspection result normal?

YES >> Replace driver seat control unit. Refer to [ADP-201, "Removal and Installation"](#).

NO >> Repair or replace harness or connector.

3.CHECK LIFTING SWITCH (FRONT)

Refer to [ADP-62, "Component Inspection"](#).

Is the inspection result normal?

YES >> GO TO 4.

NO >> Replace power seat switch. Refer to [ADP-204, "Removal and Installation"](#).

4.CHECK INTERMITTENT INCIDENT

Refer to [GI-44, "Intermittent Incident"](#).

>> INSPECTION END

Component Inspection

INFOID:000000006258041

1.CHECK LIFTING SWITCH (FRONT)

1. Turn ignition switch OFF.
2. Disconnect power seat switch (lifting switch front) connector.
3. Check continuity between power seat switch (lifting switch front) terminals.

Power seat switch (lifting switch front)		Condition		Continuity
Terminal				
35	17	Lifting switch front (down)	Operate	Existed
			Release	Not existed
	18	Lifting switch front (up)	Operate	Existed
			Release	Not existed

Is the inspection result normal?

YES >> INSPECTION END

NO >> Replace power seat switch. Refer to [ADP-204, "Removal and Installation"](#).

LIFTING SWITCH (REAR)

< DTC/CIRCUIT DIAGNOSIS >

LIFTING SWITCH (REAR)

Description

INFOID:000000006258042

Lifting switch (rear) is equipped to the power seat switch on the seat cushion side surface. The operation signal is inputted to the driver seat control unit when the lifting switch (rear) is operated.

Component Function Check

INFOID:000000006258043

1. CHECK FUNCTION

1. Select "LIFT RR SW-UP", "LIFT RR SW-DN" in "Data monitor" mode with CONSULT-III.
2. Check lifting switch (rear) signal under the following conditions.

Monitor item	Condition		Status
LIFT RR SW-UP	Lifting switch rear (up)	Operate	ON
		Release	OFF
LIFT RR SW-DN	Lifting switch rear (down)	Operate	ON
		Release	OFF

Is the indication normal?

YES >> INSPECTION END

NO >> Perform diagnosis procedure. Refer to [ADP-63, "Diagnosis Procedure"](#).

Diagnosis Procedure

INFOID:000000006258044

1. CHECK LIFTING SWITCH (REAR) SIGNAL

1. Turn ignition switch OFF.
2. Disconnect power seat switch connector.
3. Turn ignition switch ON.
4. Check voltage between power seat switch harness connector and ground.

(+)		(-)	Voltage (V) (Approx.)
Power seat switch			
Connector	Terminals	Ground	Battery voltage
B459	15		
	16		

Is the inspection result normal?

YES >> GO TO 3.

NO >> GO TO 2.

2. CHECK LIFTING SWITCH (REAR) CIRCUIT

1. Turn ignition switch OFF.
2. Disconnect driver seat control unit connector.
3. Check continuity between driver seat control unit harness connector and power seat switch harness connector.

Driver seat control unit		Power seat switch		Continuity
Connector	Terminal	Connector	Terminal	
B452	15	B459	15	Existed
	16		16	

4. Check continuity between driver seat control unit harness connector and ground.

LIFTING SWITCH (REAR)

< DTC/CIRCUIT DIAGNOSIS >

Driver seat control unit		Ground	Continuity
Connector	Terminal		
B452	15		
	16		

Is the inspection result normal?

YES >> Replace driver seat control unit. Refer to [ADP-201, "Removal and Installation"](#).

NO >> Repair or replace harness or connector.

3.CHECK LIFTING SWITCH (REAR)

Refer to [ADP-64, "Component Inspection"](#).

Is the inspection result normal?

YES >> GO TO 4.

NO >> Replace power seat switch. Refer to [ADP-204, "Removal and Installation"](#).

4.CHECK INTERMITTENT INCIDENT

Refer to [GI-44, "Intermittent Incident"](#).

>> INSPECTION END

Component Inspection

INFOID:000000006258045

1.CHECK LIFTING SWITCH (REAR)

1. Turn ignition switch OFF.
2. Disconnect power seat switch (lifting switch rear) connector.
3. Check continuity between power seat switch (lifting switch rear) terminals.

Power seat switch (lifting switch rear)		Condition		Continuity
Terminal				
35	15	Lifting switch rear (up)	Operate	Existed
			Release	Not existed
	16	Lifting switch rear (down)	Operate	Existed
			Release	Not existed

Is the inspection result normal?

YES >> INSPECTION END

NO >> Replace power seat switch. Refer to [ADP-204, "Removal and Installation"](#).

TILT SWITCH

< DTC/CIRCUIT DIAGNOSIS >

TILT SWITCH

Description

INFOID:000000006258046

Tilt switch is equipped to the steering column. The operation signal is inputted to the automatic drive positioner control unit when the tilt switch is operated.

Component Function Check

INFOID:000000006258047

1.CHECK FUNCTION

1. Select "TILT SW-UP", "TILT SW-DOWN" in "Data monitor" mode with CONSULT-III.
2. Check tilt switch signal under the following conditions.

Monitor item	Condition		Status
TILT SW-UP	Tilt switch (up)	Operate	ON
		Release	OFF
TILT SW-DOWN	Tilt switch (down)	Operate	ON
		Release	OFF

Is the indication normal?

YES >> INSPECTION END

NO >> Perform diagnosis procedure. Refer to [ADP-65, "Diagnosis Procedure"](#).

Diagnosis Procedure

INFOID:000000006258048

1.CHECK TILT SWITCH SIGNAL

1. Turn ignition switch OFF.
2. Disconnect tilt & telescopic switch connector.
3. Turn ignition switch ON.
4. Check voltage between tilt & telescopic switch harness connector and ground.

(+)		(-)	Voltage (V) (Approx.)
Tilt & telescopic switch			
Connector	Terminals	Ground	5
M102	2		
	3		

Is the inspection result normal?

YES >> GO TO 3.

NO >> GO TO 2.

2.CHECK TILT SWITCH CIRCUIT

1. Turn ignition switch OFF.
2. Disconnect automatic drive positioner control unit connector.
3. Check continuity between automatic drive positioner control unit harness connector and tilt & telescopic switch harness connector.

Automatic drive positioner control unit		Tilt & telescopic switch		Continuity
Connector	Terminal	Connector	Terminal	
M75	1	M102	2	Existed
	13		3	

4. Check continuity between automatic drive positioner control unit harness connector and ground.

TILT SWITCH

< DTC/CIRCUIT DIAGNOSIS >

Automatic drive positioner control unit		Ground	Continuity
Connector	Terminal		
M75	1		
	13		

Is the inspection result normal?

YES >> Replace automatic drive positioner control unit. Refer to [ADP-202, "Removal and Installation"](#).

NO >> Repair or replace harness or connector.

3.CHECK TILT SWITCH

Refer to [ADP-66, "Component Inspection"](#).

Is the inspection result normal?

YES >> GO TO 4.

NO >> Replace tilt & telescopic switch. Refer to [ADP-205, "Removal and Installation"](#).

4.CHECK INTERMITTENT INCIDENT

Refer to [GI-44, "Intermittent Incident"](#).

>> INSPECTION END

Component Inspection

INFOID:000000006258049

1.CHECK TILT SWITCH

1. Turn ignition switch OFF.
2. Disconnect tilt & telescopic switch connector.
3. Check continuity between tilt & telescopic switch terminals.

Tilt switch		Condition		Continuity
Terminal				
1	2	Tilt switch (upward)	Operate	Existed
			Release	Not existed
	3	Tilt switch (downward)	Operate	Existed
			Release	Not existed

Is the inspection result normal?

YES >> INSPECTION END

NO >> Replace tilt & telescopic switch. Refer to [ADP-205, "Removal and Installation"](#).

TELESCOPIC SWITCH

< DTC/CIRCUIT DIAGNOSIS >

TELESCOPIC SWITCH

Description

INFOID:000000006258050

Telescopic switch is equipped to the steering column. The operation signal is inputted to the automatic drive positioner control unit when the telescopic switch is operated.

Component Function Check

INFOID:000000006258051

1. CHECK FUNCTION

1. Select "TELESCO SW-FR", "TELESCO SW-RR" in "Data monitor" mode with CONSULT-III.
2. Check telescopic switch signal under the following conditions.

Monitor item	Condition		Status
TELESCO SW-FR	Telescopic switch (forward)	Operate	ON
		Release	OFF
TELESCO SW-RR	Telescopic switch (backward)	Operate	ON
		Release	OFF

Is the indication normal?

YES >> INSPECTION END

NO >> Perform diagnosis procedure. Refer to [ADP-67, "Diagnosis Procedure"](#).

Diagnosis Procedure

INFOID:000000006258052

1. CHECK TELESCOPIC SWITCH SIGNAL

1. Turn ignition switch OFF.
2. Disconnect tilt & telescopic switch connector.
3. Turn ignition switch ON.
4. Check voltage between tilt & telescopic switch harness connector and ground.

(+)		(-)	Voltage (V) (Approx.)
Tilt & telescopic switch			
Connector	Terminals	Ground	5
M102	5		
	4		

Is the inspection result normal?

YES >> GO TO 3.

NO >> GO TO 2.

2. CHECK TELESCOPIC SWITCH CIRCUIT

1. Turn ignition switch OFF.
2. Disconnect automatic drive positioner control unit connector.
3. Check continuity between automatic drive positioner control unit harness connector and tilt & telescopic switch harness connector.

Automatic drive positioner control unit		Tilt & telescopic switch		Continuity
Connector	Terminal	Connector	Terminal	
M75	7	M102	5	Existed
	19		4	

4. Check continuity between automatic drive positioner control unit harness connector and ground.

TELESCOPIC SWITCH

< DTC/CIRCUIT DIAGNOSIS >

Automatic drive positioner control unit		Ground	Continuity
Connector	Terminal		
M75	7		
	19		Not existed

Is the inspection result normal?

YES >> Replace automatic drive positioner control unit. Refer to [ADP-202, "Removal and Installation"](#).

NO >> Repair or replace harness or connector.

3.CHECK TELESCOPIC SWITCH

Refer to [ADP-68, "Component Inspection"](#).

Is the inspection result normal?

YES >> GO TO 4.

NO >> Replace tilt & telescopic switch. Refer to [ADP-205, "Removal and Installation"](#).

4.CHECK INTERMITTENT INCIDENT

Refer to [GI-44, "Intermittent Incident"](#).

>> INSPECTION END

Component Inspection

INFOID:000000006258053

1.CHECK TELESCOPIC SWITCH

1. Turn ignition switch OFF.
2. Disconnect tilt & telescopic switch connector.
3. Check continuity between tilt & telescopic switch terminals.

Telescopic switch		Condition		Continuity
Terminal				
1	5	Telescopic switch (forward)	Operate	Existed
			Release	Not existed
	4	Telescopic switch (backward)	Operate	Existed
			Release	Not existed

Is the inspection result normal?

YES >> INSPECTION END

NO >> Replace tilt & telescopic switch. Refer to [ADP-205, "Removal and Installation"](#).

SEAT MEMORY SWITCH

< DTC/CIRCUIT DIAGNOSIS >

SEAT MEMORY SWITCH

Description

INFOID:000000006258054

Memory switch and set switch is equipped on the seat memory switch installed to the driver side door trim. The operation signal is inputted to the driver seat control unit when the memory switch and set switch is operated.

Component Function Check

INFOID:000000006258055

1. CHECK FUNCTION

1. Select "MEMORY SW 1", "MEMORY SW 2", "SET SW" in "Data monitor" mode with CONSULT-III.
2. Check seat memory switch signal under the following conditions.

Monitor item	Condition		Status
MEMORY SW 1	Memory switch 1	Push	ON
		Release	OFF
MEMORY SW 2	Memory switch 2	Push	ON
		Release	OFF
SET SW	Set switch	Push	ON
		Release	OFF

Is the indication normal?

YES >> INSPECTION END

NO >> Perform diagnosis procedure. Refer to [ADP-69, "Diagnosis Procedure"](#).

Diagnosis Procedure

INFOID:000000006258056

1. CHECK SEAT MEMORY SWITCH SIGNAL

1. Turn ignition switch OFF.
2. Disconnect driver seat control unit connector.
3. Turn ignition switch ON.
4. Check voltage between driver seat control unit harness connector and ground.

(+)		(-)	Voltage (V) (Approx.)
Driver seat control unit			
Connector	Terminals	Ground	5
B452	27		
	28		
	29		

Is the inspection result normal?

YES >> GO TO 3.

NO >> GO TO 2.

2. CHECK MEMORY SWITCH CIRCUIT

1. Turn ignition switch OFF.
2. Disconnect seat memory switch connector.
3. Check continuity between driver seat control unit harness connector and seat memory switch harness connector.

SEAT MEMORY SWITCH

< DTC/CIRCUIT DIAGNOSIS >

Driver seat control unit		Seat memory switch		Continuity
Connector	Terminal	Connector	Terminal	
B452	27	D13	1	Existed
	28		2	
	29		3	

4. Check continuity between driver seat control unit harness connector and ground.

Driver seat control unit		Ground	Continuity
Connector	Terminal		
B452	27	Ground	Not existed
	28		
	29		

Is the inspection result normal?

YES >> Replace driver seat control unit. Refer to [ADP-201, "Removal and Installation"](#).

NO >> Repair or replace harness or connector.

3.CHECK MEMORY SWITCH GROUND CIRCUIT

Check continuity between seat memory switch harness connector and ground.

Seat memory switch		Ground	Continuity
Connector	Terminal		
D13	4	Ground	Existed

Is the inspection result normal?

YES >> GO TO 4.

NO >> Repair or replace harness or connector.

4.CHECK SEAT MEMORY SWITCH

Refer to [ADP-70, "Component Inspection"](#).

Is the inspection result normal?

YES >> GO TO 5.

NO >> Replace seat memory switch. Refer to [ADP-203, "Removal and Installation"](#).

5.CHECK INTERMITTENT INCIDENT

Refer to [GI-44, "Intermittent Incident"](#).

>> INSPECTION END

Component Inspection

INFOID:000000006258057

1.CHECK SEAT MEMORY SWITCH

1. Turn ignition switch OFF.
2. Disconnect seat memory switch connector.
3. Check continuity between seat memory switch terminals.

SEAT MEMORY SWITCH

< DTC/CIRCUIT DIAGNOSIS >

Seat memory switch		Condition		Continuity
Terminal				
4	1	Memory switch 1	Push	Existed
			Release	Not existed
	2	Memory switch 2	Push	Existed
			Release	Not existed
	3	Set switch	Push	Existed
			Release	Not existed

Is the inspection result normal?

YES >> INSPECTION END

NO >> Replace seat memory switch. Refer to [ADP-203, "Removal and Installation"](#).

A
B
C
D
E
F
G
H
I
K
L
M
N
O
P

ADP

DOOR MIRROR REMOTE CONTROL SWITCH

< DTC/CIRCUIT DIAGNOSIS >

DOOR MIRROR REMOTE CONTROL SWITCH CHANGEOVER SWITCH

CHANGEOVER SWITCH : Description

INFOID:000000006258058

Changeover switch is integrated into door mirror remote control switch.
Changeover switch has three positions (L, N and R).
It changes door mirror motor operation by transmitting control signal to automatic drive positioner control unit.

CHANGEOVER SWITCH : Component Function Check

INFOID:000000006258059

1.CHECK CHANGEOVER SWITCH FUNCTION

Check the operation on "MIR CHNG SW-R" or "MIR CHNG SW-L" in "DATA MONITOR" mode with CONSULT-III.

Monitor item	Condition
MIR CHNG SW-R/L	When operating the changeover toward the right or left side. : ON
	Other than above. : OFF

Is the inspection result normal?

YES >> Changeover switch function is OK.

NO >> Refer to [ADP-72. "CHANGEOVER SWITCH : Diagnosis Procedure"](#).

CHANGEOVER SWITCH : Diagnosis Procedure

INFOID:000000006258060

1.CHECK CHANGEOVER SWITCH INPUT SIGNAL

1. Turn ignition switch OFF.
2. Disconnect door mirror remote control switch connector.
3. Turn ignition switch ON.
4. Check voltage between door mirror remote control switch harness connector and ground.

(+)		(-)	Voltage (V) (Approx.)
Connector	Terminal		
D14	10	Ground	5
	11		

Is the inspection result normal?

YES >> GO TO 3.

NO >> GO TO 2.

2.CHECK CHANGEOVER SWITCH CIRCUIT

1. Turn ignition switch OFF.
2. Disconnect automatic drive positioner control unit connector.
3. Check continuity between automatic drive positioner control unit harness connector and door mirror remote control switch harness connector.

Automatic drive positioner control unit		Door mirror remote control switch		Continuity
Connector	Terminal	Connector	Terminal	
M75	2	D14	11	Existed
	14		10	

4. Check continuity between automatic drive positioner control unit harness connector and ground.

DOOR MIRROR REMOTE CONTROL SWITCH

< DTC/CIRCUIT DIAGNOSIS >

Automatic drive positioner control unit		Ground	Continuity
Connector	Terminal		
M75	2		
	14		Not existed

Is the inspection result normal?

- YES >> Replace automatic drive positioner control unit. Refer to [ADP-202. "Removal and Installation"](#).
 NO >> Repair or replace harness.

3.CHECK DOOR MIRROR REMOTE CONTROL SWITCH GROUND CIRCUIT

- Turn ignition switch OFF.
- Check continuity between door mirror remote control switch harness connector and ground.

Door mirror remote control switch		Ground	Continuity
Connector	Terminal		
D14	7		

Is the inspection result normal?

- YES >> GO TO 4.
 NO >> Repair or replace harness.

4.CHECK CHANGEOVER SWITCH

Check door mirror remote control switch (changeover switch).
 Refer to [ADP-73. "CHANGEOVER SWITCH : Component Inspection"](#).

Is the inspection result normal?

- YES >> GO TO 5.
 NO >> Replace door mirror remote control switch (changeover switch). Refer to [MIR-74. "Removal and Installation"](#).

5.CHECK INTERMITTENT INCIDENT

Check intermittent incident.
 Refer to [GI-44. "Intermittent Incident"](#).

>> INSPECTION END

CHANGEOVER SWITCH : Component Inspection

INFOID:0000000006258061

1.CHECK CHANGEOVER SWITCH

- Turn ignition switch OFF.
- Disconnect door mirror remote control switch connector.
- Check continuity between door mirror remote control switch terminals.

Door mirror remote control switch		Condition	Continuity	
Connector	Terminal			
D14	10			LEFT
		Other than above	Not existed	
	11	RIGHT	Existed	
		Other than above	Not existed	

Is the inspection result normal?

- YES >> INSPECTION END
 NO >> Replace door mirror remote control switch. Refer to [MIR-74. "Removal and Installation"](#).

MIRROR SWITCH

DOOR MIRROR REMOTE CONTROL SWITCH

< DTC/CIRCUIT DIAGNOSIS >

MIRROR SWITCH : Description

INFOID:000000006258062

It operates angle of the door mirror face.

It transmits mirror face adjust operation to AUTOMATIC DRIVE POSITIONER CONTROL UNIT.

MIRROR SWITCH : Component Function Check

INFOID:000000006258063

1.CHECK MIRROR SWITCH FUNCTION

Check the operation on "MIR CON SW-UP/DN" and "MIR CON SW-RH/LH" in "DATA MONITOR" mode with CONSULT-III.

Monitor item	Condition	
MIR CON SW-UP/DN	When operating the mirror switch toward the up or down side.	: ON
	Other than above.	: OFF
MIR CON SW-RH/LH	When operating the mirror switch toward the right or left side.	: ON
	Other than above.	: OFF

Is the inspection result normal?

YES >> Mirror switch function is OK.

NO >> Refer to [ADP-74, "MIRROR SWITCH : Diagnosis Procedure"](#).

MIRROR SWITCH : Diagnosis Procedure

INFOID:000000006258064

1.CHECK MIRROR SWITCH INPUT SIGNAL

1. Turn ignition switch OFF.
2. Disconnect door mirror remote control switch connector.
3. Turn ignition switch ON.
4. Check voltage between door mirror remote control switch harness connector and ground.

(+)		(-)	Voltage (V) (Approx.)
Connector	Terminal		
D14	4	Ground	5
	12		
	13		
	15		

Is the inspection result normal?

YES >> GO TO 3.

NO >> GO TO 2.

2.CHECK MIRROR SWITCH CIRCUIT

1. Turn ignition switch OFF.
2. Disconnect automatic drive positioner control unit connector.
3. Check continuity between automatic drive positioner control unit harness connector and door mirror remote control switch harness connector.

Automatic drive positioner control unit		Door mirror remote control switch		Continuity
Connector	Terminal	Connector	Terminal	
M75	3	D14	15	Existed
	4		13	
	15		12	
	16		4	

4. Check continuity between automatic drive positioner control unit harness connector and ground.

DOOR MIRROR REMOTE CONTROL SWITCH

< DTC/CIRCUIT DIAGNOSIS >

Automatic drive positioner control unit		Ground	Continuity
Connector	Terminal		
M75	3	Ground	Not existed
	4		
	15		
	16		

Is the inspection result normal?

YES >> Replace automatic drive positioner control unit. Refer to [ADP-201, "Removal and Installation"](#).

NO >> Repair or replace harness.

3.CHECK DOOR MIRROR REMOTE CONTROL SWITCH GROUND CIRCUIT

- Turn ignition switch OFF.
- Check continuity between door mirror remote control switch harness connector and ground.

Door mirror remote control switch		Ground	Continuity
Connector	Terminal		
D14	7	Ground	Existed

Is the inspection result normal?

YES >> GO TO 4.

NO >> Repair or replace harness.

4.CHECK MIRROR SWITCH

Check door mirror remote control switch (mirror switch).

Refer to [ADP-75, "MIRROR SWITCH : Component Inspection"](#).

Is the inspection result normal?

YES >> GO TO 5.

NO >> Replace door mirror remote control switch (mirror switch). Refer to [MIR-74, "Removal and Installation"](#).

5.CHECK INTERMITTENT INCIDENT

Check intermittent incident.

Refer to [GI-44, "Intermittent Incident"](#).

>> INSPECTION END

MIRROR SWITCH : Component Inspection

INFOID:000000006258065

1.CHECK MIRROR SWITCH

- Turn ignition switch OFF.
- Disconnect door mirror remote control switch connector.
- Check continuity between door mirror remote control switch terminals.

Door mirror remote control switch			Condition	Continuity	
Connector	Terminal				
D14	4	7	Mirror switch	RIGHT	Existed
				Other than above	Not existed
	13			LEFT	Existed
				Other than above	Not existed
	15			UP	Existed
				Other than above	Not existed
	12			DOWN	Existed
				Other than above	Not existed

DOOR MIRROR REMOTE CONTROL SWITCH

< DTC/CIRCUIT DIAGNOSIS >

Is the inspection result normal?

YES >> INSPECTION END

NO >> Replace door mirror remote control switch. Refer to [MIR-74, "Removal and Installation"](#).

POWER SEAT SWITCH GROUND CIRCUIT

< DTC/CIRCUIT DIAGNOSIS >

POWER SEAT SWITCH GROUND CIRCUIT

Diagnosis Procedure

INFOID:000000006258066

1. CHECK POWER SEAT SWITCH GROUND CIRCUIT

1. Turn ignition switch OFF.
2. Disconnect power seat switch connector.
3. Check continuity between power seat switch connector and ground.

Power seat switch		Ground	Continuity
Connector	Terminal		Existed
B459	35		

Is the inspection result normal?

- YES >> Check intermittent incident. Refer to [GI-44, "Intermittent Incident"](#).
NO >> Repair or replace harness or connector.

A
B
C
D
E
F
G
H
I
K
L
M
N
O
P

ADP

TILT & TELESCOPIC SWITCH GROUND CIRCUIT

< DTC/CIRCUIT DIAGNOSIS >

TILT & TELESCOPIC SWITCH GROUND CIRCUIT

Diagnosis Procedure

INFOID:000000006258067

1. CHECK TILT & TELESCOPIC SWITCH GROUND CIRCUIT

1. Turn ignition switch OFF.
2. Disconnect tilt & telescopic switch connector.
3. Check continuity between tilt & telescopic switch and ground.

Tilt & telescopic switch		Ground	Continuity
Connector	Terminal		Existed
M102	1		

Is the inspection result normal?

- YES >> Check intermittent incident. Refer to [GI-44, "Intermittent Incident"](#).
NO >> Repair or replace harness.

FRONT DOOR SWITCH (DRIVER SIDE)

< DTC/CIRCUIT DIAGNOSIS >

FRONT DOOR SWITCH (DRIVER SIDE)

Description

INFOID:000000006258068

Detects front door (driver side) open/close condition.

Component Function Check

INFOID:000000006258069

1. CHECK FUNCTION

1. Select "DOOR SW-DR" in "Data monitor" mode with CONSULT-III.
2. Check the front door switch (driver side) signal under the following conditions.

Monitor item	Condition		Status
DOOR SW-DR	Front door switch (driver side)	Open	ON
		Close	OFF

Is the inspection result normal?

YES >> INSPECTION END

NO >> Perform diagnosis procedure. Refer to [ADP-79, "Diagnosis Procedure"](#).

Diagnosis Procedure

INFOID:000000006258070

1. CHECK FRONT DOOR SWITCH (DRIVER SIDE) SIGNAL

1. Turn ignition switch OFF.
2. Disconnect front door switch (driver side) connector.
3. Check signal between BCM connector and ground with oscilloscope.

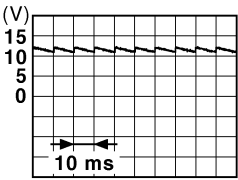
(+)		(-)	Signal (Reference value)
Connector	Terminals		
B34	2	Ground	 <p style="text-align: right;">JPMIA0011GB</p>

Is the inspection result normal?

YES >> GO TO 3.

NO >> GO TO 2.

2. CHECK FRONT DOOR SWITCH (DRIVER SIDE) CIRCUIT

1. Disconnect BCM connector.
2. Check continuity between BCM connector and front door switch (driver side) connector.

BCM		Front door switch(driver side)		Continuity
Connector	Terminal	Connector	Terminal	
M123	150	B34	2	Existed

3. Check continuity between BCM connector and ground.

BCM		Ground	Continuity
Connector	Terminal		
M123	150		Not existed

Is the inspection result normal?

FRONT DOOR SWITCH (DRIVER SIDE)

< DTC/CIRCUIT DIAGNOSIS >

YES >> Replace BCM. Refer to [BCS-85. "Exploded View"](#).

NO >> Repair or replace harness or connector.

3.CHECK FRONT DOOR SWITCH (DRIVER SIDE)

Refer to [ADP-80. "Component Inspection"](#).

Is the inspection result normal?

YES >> GO TO 4.

NO >> Replace front door switch (driver side).Refer to [DLK-348. "Removal and Installation"](#)

4.CHECK INTERMITTENT INCIDENT

Refer to [GI-44. "Intermittent Incident"](#).

>> INSPECTION END

Component Inspection

INFOID:000000006258071

1.CHECK FRONT DOOR SWITCH (DRIVER SIDE)

1. Turn ignition switch OFF.
2. Disconnect front door switch (driver side) connector.
3. Check continuity between front door switch (driver side) terminals.

Terminal		Condition		Continuity
Front door switch (driver side)				
2	Ground part of door switch	Front door switch (driver side)	Pushed	Not existed
			Released	Existed

Is the inspection result normal?

YES >> INSPECTION END

NO >> Replace front door switch (driver side).Refer to [DLK-348. "Removal and Installation"](#).

SLIDING SENSOR

< DTC/CIRCUIT DIAGNOSIS >

SLIDING SENSOR

Description

INFOID:000000006258072

- The sliding sensor is installed to the seat cushion frame.
- The pulse signal is inputted to the driver seat control unit when sliding is performed.
- The driver seat control unit counts the pulse and calculates the sliding amount of the seat.

Component Function Check

INFOID:000000006258073

1.CHECK FUNCTION

1. Select "SLIDE PULSE" in "Data monitor" mode with CONSULT-III.
2. Check sliding sensor signal under the following conditions.

Monitor item	Condition		Valve
SLIDE PULSE	Seat sliding	Operate (forward)	Change (increase) ^{*1}
		Operate (backward)	Change (decrease) ^{*1}
		Release	No change ^{*1}

*1: The value at the seat position attained when the battery is connected is considered to be 32768.

Is the indication normal?

YES >> INSPECTION END

NO >> Perform diagnosis procedure. Refer to [ADP-81, "Diagnosis Procedure"](#).

Diagnosis Procedure

INFOID:000000006258074

1.CHECK SLIDING SENSOR SIGNAL

1. Turn ignition switch ON.
2. Read voltage signal between driver seat control unit harness connector and ground with oscilloscope.

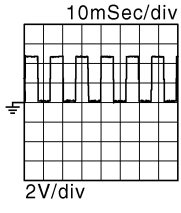
(+)		(-)	Condition	Signal (Reference value)
Driver seat control unit Connector	Terminals			
B452	19	Ground	Seat sliding	 <p>10mSec/div 2V/div JMJA0119ZZ</p>
			Operate	
			Other than above	0 or 5

Is the inspection result normal?

YES >> Replace driver seat control unit. Refer to [ADP-201, "Removal and Installation"](#).

NO >> GO TO 2.

2.CHECK SLIDING SENSOR CIRCUIT

1. Turn ignition switch OFF.
2. Disconnect driver seat control unit and sliding sensor connector.
3. Check continuity between driver seat control unit harness connector and sliding sensor harness connector.

SLIDING SENSOR

< DTC/CIRCUIT DIAGNOSIS >

Driver seat control unit		Sliding motor		Continuity
Connector	Terminal	Connector	Terminal	
B452	19	B461	19	Existed

4. Check continuity between driver seat control unit harness connector and ground.

Driver seat control unit		Ground	Continuity
Connector	Terminal		
B452	19		Not existed

Is the inspection result normal?

YES >> GO TO 3.

NO >> Repair or replace harness or connector.

3.CHECK SLIDING SENSOR POWER SUPPLY

1. Connect driver seat control unit connector.
2. Turn ignition switch ON.
3. Check voltage between sliding motor harness connector and ground.

(+)		(-)	Voltage (V) (Approx.)
Sliding motor			
Connector	Terminals		
B461	33	Ground	Battery voltage

Is the inspection result normal?

YES >> GO TO 5.

NO >> GO TO 4.

4.CHECK SLIDING SENSOR POWER SUPPLY CIRCUIT

1. Turn ignition switch OFF.
2. Disconnect driver seat control unit connector.
3. Check continuity between driver seat control unit harness connector and sliding motor harness connector.

Driver seat control unit		Sliding motor		Continuity
Connector	Terminal	Connector	Terminal	
B452	33	B461	33	Existed

4. Check continuity between driver seat control unit harness connector and ground.

Driver seat control unit		Ground	Continuity
Connector	Terminal		
B452	33		Not existed

Is the inspection result normal?

YES >> Replace driver seat control unit. Refer to [ADP-201, "Removal and Installation"](#).

NO >> Repair or replace harness or connector.

5.CHECK SLIDING SENSOR GROUND

1. Turn ignition switch OFF.
2. Check continuity between sliding sensor harness connector and ground.

Sliding motor		Ground	Continuity
Connector	Terminal		
B461	45		Existed

Is the inspection result normal?

YES >> Replace sliding motor.

SLIDING SENSOR

< DTC/CIRCUIT DIAGNOSIS >

NO >> Repair or replace harness or connector.

A

B

C

D

E

F

G

H

I

ADP

K

L

M

N

O

P

RECLINING SENSOR

< DTC/CIRCUIT DIAGNOSIS >

RECLINING SENSOR

Description

INFOID:000000006258075

- The reclining motor is installed to the seatback frame.
- The pulse signal is inputted to the driver seat control unit when the reclining is operated.
- The driver seat control unit counts the pulse and calculates the reclining amount of the seat.

Component Function Check

INFOID:000000006258076

1. CHECK FUNCTION

1. Select "RECLN PULSE" in "Data monitor" mode with CONSULT-III.
2. Check reclining sensor signal under the following conditions.

Monitor item	Condition		Value
RECLN PULSE	Seat reclining	Operate (forward)	Change (increase) ^{*1}
		Operate (backward)	Change (decrease) ^{*1}
		Release	No change ^{*1}

*1: The value at the seat position attained when the battery is connected is considered to be 32768.

Is the indication normal?

YES >> INSPECTION END

NO >> Perform diagnosis procedure. Refer to [ADP-84. "Diagnosis Procedure"](#).

Diagnosis Procedure

INFOID:000000006258077

1. CHECK RECLINING SENSOR SIGNAL

1. Turn ignition switch ON.
2. Read voltage signal between driver seat control unit harness connector and ground with oscilloscope.

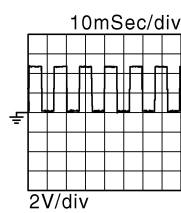
(+)		(-)	Condition	Signal (Reference value)
Driver seat control unit				
Connector	Terminals			
B452	20	Ground	Seat reclining	 <p>10mSec/div 2V/div JMJA0119ZZ</p>
			Operate	
			Other than above	0 or 5

Is the inspection result normal?

YES >> Replace driver seat control unit. Refer to [ADP-201. "Removal and Installation"](#).

NO >> GO TO 2.

2. CHECK RECLINING SENSOR CIRCUIT

1. Turn ignition switch OFF.
2. Disconnect driver seat control unit and reclining motor connector.
3. Check continuity between driver seat control unit harness connector and reclining motor harness connector.

RECLINING SENSOR

< DTC/CIRCUIT DIAGNOSIS >

Driver seat control unit		Reclining motor		Continuity
Connector	Terminal	Connector	Terminal	
B452	20	B454	20	Existed

4. Check continuity between driver seat control unit harness connector and ground.

Driver seat control unit		Ground	Continuity
Connector	Terminal		
B452	20		Not existed

Is the inspection result normal?

YES >> GO TO 3.

NO >> Repair or replace harness or connector.

3. CHECK RECLINING SENSOR POWER SUPPLY

1. Connect driver seat control unit connector.
2. Turn ignition switch ON.
3. Check voltage between reclining motor harness connector and ground.

(+)		(-)	Voltage (V) (Approx.)
Reclining motor			
Connector	Terminals		
B454	33	Ground	Battery voltage

Is the inspection result normal?

YES >> GO TO 5.

NO >> GO TO 4.

4. CHECK RECLINING SENSOR POWER SUPPLY CIRCUIT

1. Turn ignition switch OFF.
2. Disconnect driver seat control unit connector.
3. Check continuity between driver seat control unit harness connector and reclining motor harness connector.

Driver seat control unit		Reclining motor		Continuity
Connector	Terminal	Connector	Terminal	
B452	33	B454	33	Existed

4. Check continuity between driver seat control unit harness connector and ground.

Driver seat control unit		Ground	Continuity
Connector	Terminal		
B452	33		Not existed

Is the inspection result normal?

YES >> Replace driver seat control unit. Refer to [ADP-201, "Removal and Installation"](#).

NO >> Repair or replace harness or connector.

5. CHECK RECLINING SENSOR GROUND

1. Turn ignition switch OFF.
2. Check continuity between reclining motor harness connector and ground.

Reclining motor		Ground	Continuity
Connector	Terminal		
B454	46		Existed

Is the inspection result normal?

RECLINING SENSOR

< DTC/CIRCUIT DIAGNOSIS >

- YES >> Replace reclining motor.
- NO >> Repair or replace harness or connector.

LIFTING SENSOR (FRONT)

< DTC/CIRCUIT DIAGNOSIS >

LIFTING SENSOR (FRONT)

Description

INFOID:000000006258078

- The lifting sensor (front) is installed to the seat cushion frame.
- The pulse signal is inputted to the driver seat control unit when the lifting (front) is operated.
- The driver seat control unit counts the pulse and calculates the lifting (front) amount of the seat.

Component Function Check

INFOID:000000006258079

1.CHECK FUNCTION

1. Select "LIFT FR PULSE" in "Data monitor" mode with CONSULT-III.
2. Check the lifting sensor (front) signal under the following conditions.

Monitor item	Condition		Value
LIFT FR PULSE	Seat lifting (front)	Operate (Up)	Change (increase) ^{*1}
		Operate (Down)	Change (decrease) ^{*1}
		Release	No change ^{*1}

^{*1}:The value at the seat position attained when the battery is connected is considered to be 32768.

Is the indication normal?

YES >> INSPECTION END

NO >> Perform diagnosis procedure. Refer to [ADP-87, "Diagnosis Procedure"](#).

Diagnosis Procedure

INFOID:000000006258080

1.CHECK LIFTING SENSOR (FRONT) SIGNAL

1. Turn ignition switch ON.
2. Read the voltage signal driver seat control unit harness connector and ground with an oscilloscope.

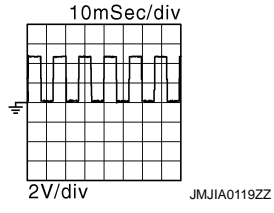
(+)		(-)	Condition	Voltage (V) (Approx.)
Driver seat control unit				
Connector	Terminals			
B452	22	Ground	Seat Lifting (front)	
			Operate	
			Other than above	0 or 5

Is the inspection result normal?

YES >> Replace driver seat control unit. Refer to [ADP-201, "Removal and Installation"](#).

NO >> GO TO 2.

2.CHECK LIFTING SENSOR (FRONT) CIRCUIT

1. Turn ignition switch OFF.
2. Disconnect driver seat control unit and lifting motor (front) connector.
3. Check continuity between driver seat control unit harness connector and lifting motor (front) harness connector.

LIFTING SENSOR (FRONT)

< DTC/CIRCUIT DIAGNOSIS >

Driver seat control unit		Lifting motor (front)		Continuity
Connector	Terminal	Connector	Terminal	
B452	22	B455	22	Existed

4. Check continuity between driver seat control unit harness connector and ground.

Driver seat control unit		Ground	Continuity
Connector	Terminal		
B452	22		Not existed

Is the inspection result normal?

YES >> GO TO 3.

NO >> Repair or replace harness or connector.

3.CHECK LIFTING SENSOR (FRONT) POWER SUPPLY

1. Connect driver seat control unit connector.
2. Turn ignition switch ON.
3. Check voltage between lifting motor (front) harness connector and ground.

Lifting motor (front)		(-)	Voltage (V) (Approx.)
Connector	Terminals		
B455	33	Ground	Battery voltage

Is the inspection result normal?

YES >> GO TO 5.

NO >> GO TO 4.

4.CHECK LIFTING SENSOR (FRONT) POWER SUPPLY CIRCUIT

1. Turn ignition switch OFF.
2. Disconnect driver seat control unit connector.
3. Check continuity between driver seat control unit harness connector and lifting motor (front) harness connector.

Driver seat control unit		Lifting motor (front)		Continuity
Connector	Terminal	Connector	Terminal	
B452	33	B455	33	Existed

4. Check continuity between driver seat control unit harness connector and ground.

Driver seat control unit		Ground	Continuity
Connector	Terminal		
B452	33		Not existed

Is the inspection result normal?

YES >> Replace driver seat control unit. Refer to [ADP-201, "Removal and Installation"](#).

NO >> Repair or replace harness or connector.

5.CHECK LIFTING SENSOR (FRONT) GROUND

1. Turn ignition switch OFF.
2. Check continuity between lifting motor (front) harness connector and ground.

Lifting motor (front)		Ground	Continuity
Connector	Terminal		
B455	48		Existed

Is the inspection result normal?

LIFTING SENSOR (FRONT)

< DTC/CIRCUIT DIAGNOSIS >

YES >> Replace lifting motor (front).
NO >> Repair or replace harness or connector.

A

B

C

D

E

F

G

H

I

ADP

K

L

M

N

O

P

LIFTING SENSOR (REAR)

< DTC/CIRCUIT DIAGNOSIS >

LIFTING SENSOR (REAR)

Description

INFOID:000000006258081

- The lifting sensor (rear) is installed to the seat cushion frame.
- The pulse signal is inputted to the driver seat control unit when the lifting (rear) is operated.
- The driver seat control unit counts the pulse and calculates the lifting (rear) amount of the seat.

Component Function Check

INFOID:000000006258082

1. CHECK FUNCTION

1. Select "LIFT RR PULSE" in "Data monitor" mode with CONSULT-III.
2. Check lifting sensor (rear) signal under the following conditions.

Monitor item	Condition		Value
LIFT RR PULSE	Seat lifting (rear)	Operate (Up)	Change (increase) ^{*1}
		Operate (Down)	Change (decrease) ^{*1}
		Release	No change ^{*1}

^{*1}: The value at the seat position attained when the battery is connected is considered to be 32768.

Is the indication normal?

YES >> INSPECTION END

NO >> Perform diagnosis procedure. Refer to [ADP-90, "Diagnosis Procedure"](#).

Diagnosis Procedure

INFOID:000000006258083

1. CHECK LIFTING SENSOR (REAR) SIGNAL

1. Turn ignition switch ON.
2. Read voltage signal between driver seat control unit harness connector and ground with oscilloscope.

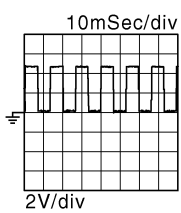
(+) Driver seat control unit		(-)	Condition	Voltage (V) (Approx.)
Connector	Terminals			
B452	21	Ground	Seat Lifting (rear)	
			Operate	
			Other than above	0 or 5

Is the inspection result normal?

YES >> Replace driver seat control unit. Refer to [ADP-201, "Removal and Installation"](#).

NO >> GO TO 2.

2. CHECK LIFTING SENSOR (REAR) CIRCUIT

1. Turn ignition switch OFF.
2. Disconnect driver seat control unit and lifting motor (rear) connector.
3. Check the continuity between driver seat control unit harness connector and lifting motor (rear) harness connector.

LIFTING SENSOR (REAR)

< DTC/CIRCUIT DIAGNOSIS >

Driver seat control unit		Lifting motor (rear)		Continuity
Connector	Terminal	Connector	Terminal	
B452	21	B456	21	Existed

4. Check the continuity between driver seat control unit harness connector and ground.

Driver seat control unit		Ground	Continuity
Connector	Terminal		
B452	21		Not existed

Is the inspection result normal?

YES >> GO TO 3.

NO >> Repair or replace harness or connector.

3.CHECK LIFTING SENSOR (REAR) POWER SUPPLY

1. Connect driver seat control unit connector.
2. Turn ignition switch ON.
3. Check the voltage between lifting motor (rear) harness connector and ground.

Lifting motor (rear)		Ground	Voltage (V) (Approx.)
Connector	Terminals		
B456	33		Battery voltage

Is the inspection result normal?

YES >> GO TO 5.

NO >> GO TO 4.

4.CHECK LIFTING SENSOR (REAR) POWER SUPPLY CIRCUIT

1. Turn ignition switch OFF.
2. Disconnect driver seat control unit connector.
3. Check the continuity between driver seat control unit harness connector and lifting motor (rear) harness connector.

Driver seat control unit		Lifting motor (rear)		Continuity
Connector	Terminal	Connector	Terminal	
B452	33	B456	33	Existed

4. Check the continuity between driver seat control unit harness connector and ground.

Driver seat control unit		Ground	Continuity
Connector	Terminal		
B452	33		Not existed

Is the inspection result normal?

YES >> Replace driver seat control unit. Refer to [ADP-201, "Removal and Installation"](#).

NO >> Repair or replace harness or connector.

5.CHECK LIFTING SENSOR (REAR) GROUND

1. Turn ignition switch OFF.
2. Check the continuity between lifting motor (rear) harness connector and ground.

Lifting motor (rear)		Ground	Continuity
Connector	Terminal		
B456	47		Existed

Is the inspection result normal?

LIFTING SENSOR (REAR)

< DTC/CIRCUIT DIAGNOSIS >

- YES >> Replace lifting motor (rear).
- NO >> Repair or replace harness or connector.

TILT SENSOR

< DTC/CIRCUIT DIAGNOSIS >

TILT SENSOR

Description

INFOID:000000006258084

- The tilt sensor is installed to the steering column assembly.
- The pulse signal is inputted to the driver seat control unit when the tilt is operated.
- The driver seat control unit counts the pulse and calculates the tilt amount of the steering column.

Component Function Check

INFOID:000000006258085

1. CHECK FUNCTION

1. Select "TILT PULSE" in "Data monitor" mode with CONSULT-III.
2. Check tilt sensor signal under the following conditions.

Monitor item	Condition		Value
TILT PULSE	Steering column	Operate (UP-WARD)	Change (increase)*1
		Operate (DOWN-WARD)	Change (decrease)
		Release	No change*1

*1: The value at the seat position attained when the battery is connected is considered to be 32768.

Is the indication normal?

YES >> INSPECTION END

NO >> Perform diagnosis procedure. Refer to [ADP-93, "Diagnosis Procedure"](#).

Diagnosis Procedure

INFOID:000000006258086

1. CHECK TILT SENSOR SIGNAL

1. Turn ignition switch ON.
2. Check voltage signal between driver seat control unit connector and ground with oscilloscope.

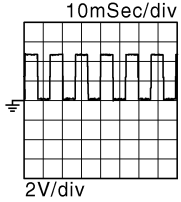
(+)		(-)	Condition	Voltage (V) (Approx.)
Driver seat control unit				
Connector	Terminals			
B452	30	Ground	Steering column	
			Other than above	

Is the inspection result normal?

YES >> Replace driver seat control unit. Refer to [ADP-201, "Removal and Installation"](#).

NO >> GO TO 2.

2. CHECK TILT SENSOR CIRCUIT

1. Turn ignition switch OFF.
2. Disconnect driver seat control unit and tilt motor connector.
3. Check continuity between driver seat control unit harness connector and tilt motor harness connector.

Driver seat control unit		Tilt motor		Continuity
Connector	Terminal	Connector	Terminal	
B452	30	M116	5	Existed

4. Check continuity between driver seat control unit harness connector and ground.

TILT SENSOR

< DTC/CIRCUIT DIAGNOSIS >

Driver seat control unit		Ground	Continuity
Connector	Terminal		
B452	5		

Is the inspection result normal?

YES >> GO TO 3.

NO >> Repair or replace harness or connector.

3. CHECK TILT SENSOR POWER SUPPLY

1. Connect automatic drive positioner control unit connector.
2. Turn ignition switch ON.
3. Check voltage between tilt motor harness connector and ground.

(+)		(-)	Voltage (V) (Approx.)	
Tilt motor				
Connector	Terminals			
M116	4	Ground	Battery voltage	

Is the inspection result normal?

YES >> GO TO 5.

NO >> GO TO 4.

4. CHECK TILT SENSOR POWER SUPPLY CIRCUIT

1. Turn ignition switch OFF.
2. Disconnect automatic drive positioner control unit connector.
3. Check continuity between automatic drive positioner control unit harness connector and tilt motor harness connector.

Automatic drive positioner control unit		Tilt motor		Continuity
Connector	Terminal	Connector	Terminal	
M104	27	M116	4	Existed

4. Check continuity between automatic drive positioner control unit harness connector and ground.

Automatic drive positioner control unit		Ground	Continuity
Connector	Terminal		
M104	27		

Is the inspection result normal?

YES >> Replace automatic drive positioner control unit. Refer to [ADP-202, "Removal and Installation"](#).

NO >> Repair or replace harness or connector.

5. CHECK TILT SENSOR GROUND CIRCUIT

1. Turn ignition switch OFF.
2. Disconnect automatic drive positioner control unit connector.
3. Check continuity between automatic drive positioner control unit harness connector and tilt motor harness connector.

Automatic drive positioner control unit		Tilt motor		Continuity
Connector	Terminal	Connector	Terminal	
M75	20	M116	6	Existed

Is the inspection result normal?

YES >> Replace tilt motor.

NO >> Repair or replace harness or connector.

TELESCOPIC SENSOR

< DTC/CIRCUIT DIAGNOSIS >

TELESCOPIC SENSOR

Description

INFOID:000000006258087

- The telescopic sensor is installed to the steering column assembly.
- The pulse signal is inputted to the driver seat control unit when telescopic is performed.
- The driver seat control unit counts the pulse and calculates the telescopic amount of the steering column.

Component Function Check

INFOID:000000006258088

1.CHECK FUNCTION

1. Select "TELESCO PULSE" in "Data monitor" mode with CONSULT-III.
2. Check telescopic sensor signal under the following conditions.

Monitor item	Condition		Valve
TELESCO PULSE	Steering column	Operate (forward)	Change (increase) ^{*1}
		Operate (backward)	Change (decrease)
		Release	No change ^{*1}

*1: The value at the seat position attained when the battery is connected is considered to be 32768.

Is the indication normal?

YES >> INSPECTION END

NO >> Perform diagnosis procedure. Refer to [ADP-95. "Diagnosis Procedure"](#).

Diagnosis Procedure

INFOID:000000006258089

1.CHECK TELESCOPIC SENSOR SIGNAL

1. Turn ignition switch ON.
2. Check voltage signal between driver seat control unit connector and ground with oscilloscope.

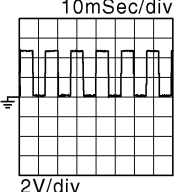
(+)		(-)	Condition	Voltage (V) (Approx.)
Connector	Terminals			
B452	31	Ground	Steering column	
			Other than above	0 or 5

Is the inspection result normal?

YES >> Replace driver seat control unit. Refer to [ADP-201. "Removal and Installation"](#).

NO >> GO TO 2.

2.CHECK TELESCOPIC SENSOR CIRCUIT

1. Turn ignition switch OFF.
2. Disconnect driver seat control unit and telescopic motor connector.
3. Check continuity between driver seat control unit harness connector and telescopic motor harness connector.

TELESCOPIC SENSOR

< DTC/CIRCUIT DIAGNOSIS >

Driver seat control unit		Telescopic motor		Continuity
Connector	Terminal	Connector	Terminal	
B452	31	M117	5	Existed

4. Check continuity between driver seat control unit harness connector and ground.

Driver seat control unit		Ground	Continuity
Connector	Terminal		
B452	31		Not existed

Is the inspection result normal?

YES >> GO TO 3.

NO >> Repair or replace harness or connector.

3. CHECK TELESCOPIC SENSOR POWER SUPPLY

1. Connect driver seat control unit connector.
2. Turn ignition switch ON.
3. Check voltage between telescopic motor harness connector and ground.

(+)		(-)	Voltage (V) (Approx.)
Telescopic motor			
Connector	Terminals		
M117	4	Ground	Battery voltage

Is the inspection result normal?

YES >> GO TO 5.

NO >> GO TO 4.

4. CHECK TELESCOPIC SENSOR POWER SUPPLY CIRCUIT

1. Turn ignition switch OFF.
2. Disconnect automatic drive positioner control unit connector.
3. Check continuity between automatic drive positioner control unit harness connector and telescopic motor harness connector.

Automatic drive positioner control unit		Telescopic motor		Continuity
Connector	Terminal	Connector	Terminal	
M104	27	M117	4	Existed

4. Check continuity between automatic drive positioner control unit harness connector and ground.

Automatic drive positioner control unit		Ground	Continuity
Connector	Terminal		
M104	27		Not existed

Is the inspection result normal?

YES >> Replace automatic drive positioner control unit. Refer to [ADP-202. "Removal and Installation"](#).

NO >> Repair or replace harness or connector.

5. CHECK TELESCOPIC SENSOR GROUND CIRCUIT

1. Turn ignition switch OFF.
2. Disconnect automatic drive positioner control unit connector.
3. Check continuity between automatic drive positioner control unit harness connector and telescopic motor harness connector.

Automatic drive positioner control unit		Telescopic motor		Continuity
Connector	Terminal	Connector	Terminal	
M75	20	M117	6	Existed

TELESCOPIC SENSOR

< DTC/CIRCUIT DIAGNOSIS >

Is the inspection result normal?

YES >> Replace telescopic motor.

NO >> Repair or replace harness or connector.

A

B

C

D

E

F

G

H

I

ADP

K

L

M

N

O

P

MIRROR SENSOR

< DTC/CIRCUIT DIAGNOSIS >

MIRROR SENSOR DRIVER SIDE

DRIVER SIDE : Description

INFOID:000000006258090

- The mirror sensor (driver side) is installed to the door mirror (driver side).
- The resistance of 2 sensors (horizontal and vertical) is changed when the door mirror (driver side) is operated.
- Automatic drive positioner control unit calculates the door mirror position according to the change of the voltage of 2 sensor input terminals.

DRIVER SIDE : Component Function Check

INFOID:000000006258091

1.CHECK FUNCTION

1. Select "MIR/SEN LH U-D", "MIR/SEN LH R-L" in "Data monitor" with CONSULT-III.
2. Check mirror sensor (driver side) signal under the following condition.

Monitor item	Condition	Value
MIR/SEN LH U-D	Door mirror (driver side)	Change between 3.4 [V] (close to peak) 0.6 [V] (close to valley)
MIR/SEN LH R-L		Change between 0.6 [V] (close to left edge) 3.4 [V] (close to right edge)

Is the indication normal?

YES >> INSPECTION END

NO >> Perform diagnosis procedure. Refer to [ADP-98. "DRIVER SIDE : Diagnosis Procedure"](#).

DRIVER SIDE : Diagnosis Procedure

INFOID:000000006258092

1.CHECK DOOR MIRROR (DRIVER SIDE) SENSOR POWER SUPPLY

1. Turn ignition switch OFF.
2. Disconnect door mirror (driver side) connector.
3. Turn ignition switch ON.
4. Check voltage between door mirror (driver side) harness connector and ground.

(+)		(-)	Voltage (V) (Approx.)
Door mirror (driver side)			
Connector	Terminals	Ground	5
D3	23		

Is the inspection result normal?

YES >> GO TO 3.

NO >> GO TO 2.

2.CHECK DOOR MIRROR (DRIVER SIDE) SENSOR POWER SUPPLY CIRCUIT

1. Turn ignition switch OFF.
2. Disconnect automatic drive positioner control unit connector.
3. Check continuity between automatic drive positioner control unit harness connector and door mirror (driver side) harness connector.

Automatic drive positioner control unit		Door mirror (driver side)		Continuity
Connector	Terminal	Connector	Terminal	
M75	21	D3	23	Existed

4. Check continuity between automatic drive positioner control unit harness connector and ground.

MIRROR SENSOR

< DTC/CIRCUIT DIAGNOSIS >

Automatic drive positioner control unit		Ground	Continuity
Connector	Terminal		
M75	21		Not existed

Is the inspection result normal?

YES >> Replace automatic drive positioner control unit. Refer to [ADP-202, "Removal and Installation"](#).

NO >> Repair or replace harness or connector.

3.CHECK DOOR MIRROR (DRIVER SIDE) SENSOR GROUND

1. Turn ignition switch OFF.
2. Disconnect automatic drive positioner control unit connector.
3. Check continuity between automatic drive positioner control unit harness connector and door mirror (driver side) harness connector.

Automatic drive positioner control unit		Door mirror (driver side)		Continuity
Connector	Terminal	Connector	Terminal	
M75	20	D3	24	

Is the inspection result normal?

YES >> GO TO 4.

NO >> Repair or replace harness or connector.

4.CHECK DOOR MIRROR (DRIVER SIDE) SENSOR CIRCUIT

1. Check continuity between automatic drive positioner control unit harness connector and door mirror (driver side) harness connector.

Automatic drive positioner control unit		Door mirror (driver side)		Continuity
Connector	Terminal	Connector	Terminal	
M75	6	D3	21	
	18		22	

2. Check continuity between automatic drive positioner control unit harness connector and ground.

Automatic drive positioner control unit		Ground	Continuity
Connector	Terminal		
M75	6		Not existed
	18		

Is the inspection result normal?

YES >> Replace door mirror sensor. (Built in driver side mirror.)

NO >> Repair or replace harness or connector.

PASSENGER SIDE

PASSENGER SIDE : Description

INFOID:000000006258093

- The mirror sensor (passenger side) is installed to the door mirror (passenger side).
- The resistance of 2 sensors (horizontal and vertical) is changed when the door mirror (passenger side) is operated.
- Automatic drive positioner control unit calculates the door mirror position according to the change of the voltage of 2 sensor input terminals.

PASSENGER SIDE : Component Function Check

INFOID:000000006258094

1.CHECK FUNCTION

1. Select "MIR/SEN RH U-D", "MIR/SEN RH R-L" in "Data monitor" with CONSULT-III.
2. Check the mirror sensor (passenger side) signal under the following conditions.

MIRROR SENSOR

< DTC/CIRCUIT DIAGNOSIS >

Monitor item	Condition	Value
MIR/SEN RH U-D	Door mirror (passenger side)	Change between 3.4 [V] (close to peak) 0.6 [V] (close to valley)
MIR/SEN RH R-L		Change between 3.4 [V] (close to left edge) 0.6 [V] (close to right edge)

Is the indication normal?

YES >> INSPECTION END

NO >> Perform diagnosis procedure. Refer to [ADP-100. "PASSENGER SIDE : Diagnosis Procedure"](#).

PASSENGER SIDE : Diagnosis Procedure

INFOID:000000006258095

1. CHECK DOOR MIRROR SENSOR (PASSENGER SIDE) POWER SUPPLY

1. Turn ignition switch OFF.
2. Disconnect door mirror (passenger side) connector.
3. Turn ignition switch ON.
4. Check voltage between door mirror (passenger side) harness connector and ground.

(+)		(-)	Voltage (V) (Approx.)
Door mirror (passenger side)			
Connector	Terminals	Ground	5
D43	23		

Is the inspection result normal?

YES >> GO TO 3.

NO >> GO TO 2.

2. CHECK DOOR MIRROR (PASSENGER SIDE) SENSOR POWER SUPPLY CIRCUIT

1. Turn ignition switch OFF.
2. Disconnect automatic drive positioner control unit connector.
3. Check continuity between automatic drive positioner control unit harness connector and door mirror (passenger side) harness connector.

Automatic drive positioner control unit		Door mirror (passenger side)		Continuity
Connector	Terminal	Connector	Terminal	
M75	21	D43	23	Existed

4. Check continuity between automatic drive positioner control unit harness connector and ground.

Automatic drive positioner control unit		Ground	Continuity
Connector	Terminal		
M75	21		Not existed

Is the inspection result normal?

YES >> Replace automatic drive positioner control unit. Refer to [ADP-202. "Removal and Installation"](#).

NO >> Repair or replace harness or connector.

3. CHECK DOOR MIRROR (PASSENGER SIDE) SENSOR GROUND

1. Turn ignition switch OFF.
2. Disconnect automatic drive positioner control unit connector.
3. Check continuity between automatic drive positioner control unit harness connector and door mirror (passenger side) connector.

MIRROR SENSOR

< DTC/CIRCUIT DIAGNOSIS >

Automatic drive positioner control unit		Door mirror (passenger side)		Continuity
Connector	Terminal	Connector	Terminal	
M75	20	D43	24	Existed

Is the inspection result normal?

YES >> GO TO 4.

NO >> Repair or replace harness or connector.

4. CHECK DOOR MIRROR (PASSENGER SIDE) SENSOR HARNESS CONTINUITY

1. Turn ignition switch OFF.
2. Disconnect automatic drive positioner control unit and door mirror (passenger side) connector.
3. Check continuity between automatic drive positioner control unit harness connector and door mirror (passenger side) harness connector.

Automatic drive positioner control unit		Door mirror (passenger side)		Continuity
Connector	Terminal	Connector	Terminal	
M75	5	D43	21	Existed
	17		22	

4. Check continuity between automatic drive positioner control unit harness connector and ground.

Automatic drive positioner control unit		Ground	Continuity
Connector	Terminal		
M75	5		Not existed
	17		

Is the inspection result normal?

YES >> Replace door mirror sensor. (Built in passenger side door mirror.)

NO >> Repair or replace harness or connector.

ADP

K

L

M

N

O

P

SLIDING MOTOR

< DTC/CIRCUIT DIAGNOSIS >

SLIDING MOTOR

Description

INFOID:000000006258096

- The sliding motor is installed to the seat cushion frame.
- The sliding motor is installed with the driver seat control unit.
- The seat is slid forward/backward by changing the rotation direction of sliding motor.

Component Function Check

INFOID:000000006258097

1. CHECK FUNCTION

1. Select "SEAT SLIDE" in "Active test" mode with CONSULT-III.
2. Check the sliding motor operation.

Test item		Description	
SEAT SLIDE	OFF	Seat sliding	Stop
	FR		Forward
	RR		Backward

Is the operation of relevant parts normal?

YES >> INSPECTION END

NO >> Perform diagnosis procedure. Refer to [ADP-102. "Diagnosis Procedure"](#).

Diagnosis Procedure

INFOID:000000006258098

1. CHECK SLIDING MOTOR POWER SUPPLY

1. Turn ignition switch OFF.
2. Disconnect sliding motor connector.
3. Turn the ignition switch ON.
4. Perform "Active test" ("SEAT SLIDE") with CONSULT-III
5. Check voltage between sliding motor harness connector and ground.

(+)		(-)	Condition	Voltage (V) (Approx.)	
Sliding motor					
Connector	Terminals				
B461	51	Ground	SEAT SLIDE	OFF	0
				FR (forward)	Battery voltage
				RR (backward)	0
	50			OFF	0
				FR (forward)	0
				RR (backward)	Battery voltage

Is the inspection result normal?

YES >> Replace sliding motor. (Built in seat slide cushion frame.)

NO >> GO TO 2.

2. CHECK SLIDING MOTOR CIRCUIT

1. Turn ignition switch OFF.
2. Disconnect driver seat control unit connector.
3. Check continuity between driver seat control unit harness connector and sliding motor harness connector.

Driver seat control unit		Sliding motor		Continuity
Connector	Terminal	Connector	Terminal	
B451	4	B461	51	Existed
	3		50	

SLIDING MOTOR

< DTC/CIRCUIT DIAGNOSIS >

4. Check continuity between driver seat control unit harness connector and ground.

Driver seat control unit		Ground	Continuity
Connector	Terminal		
B451	4		Not existed
	3		

Is the inspection result normal?

- YES >> Replace driver seat control unit. Refer to [ADP-201, "Removal and Installation"](#).
- NO >> Repair or replace harness or connector.

A
B
C
D
E
F
G
H
I
K
L
M
N
O
P

ADP

RECLINING MOTOR

< DTC/CIRCUIT DIAGNOSIS >

RECLINING MOTOR

Description

INFOID:000000006258099

- The reclining motor is installed to the seat back frame.
- The reclining motor is activated with the driver seat control unit.
- The seatback is reclined forward/backward by changing the rotation direction of reclining motor.

Component Function Check

INFOID:000000006258100

1.CHECK FUNCTION

1. Select "SEAT RECLINING" in "Active test" mode with CONSULT-III.
2. Check the reclining motor operation.

Test item		Description	
SEAT RECLINING	OFF	Seat reclining	Stop
	FR		Forward
	RR		Backward

Is the operation of relevant parts normal?

YES >> INSPECTION END

NO >> Perform diagnosis procedure. Refer to [ADP-104. "Diagnosis Procedure"](#).

Diagnosis Procedure

INFOID:000000006258101

1.CHECK RECLINING MOTOR POWER SUPPLY

1. Turn ignition switch OFF.
2. Disconnect reclining motor connector.
3. Turn the ignition switch ON.
4. Perform "Active test" ("SEAT RECLINING") with CONSULT-III
5. Check voltage between reclining motor harness connector and ground.

(+)		(-)	Condition	Voltage (V) (Approx.)	
Reclining motor					
Connector	Terminals				
B454	53	Ground	SEAT RECLINING	OFF	0
				FR (forward)	Battery voltage
				RR (backward)	0
	52			OFF	0
				FR (forward)	0
				RR (backward)	Battery voltage

Is the inspection result normal?

YES >> Replace reclining motor. (Built in seat back frame.)

NO >> GO TO 2.

2.CHECK RECLINING MOTOR CIRCUIT

1. Turn ignition switch OFF.
2. Disconnect driver seat control unit connector.
3. Check continuity between driver seat control unit harness connector and reclining motor harness connector.

RECLINING MOTOR

< DTC/CIRCUIT DIAGNOSIS >

Driver seat control unit		Reclining motor		Continuity
Connector	Terminal	Connector	Terminal	
B451	6	B454	53	Existed
	5		52	

4. Check continuity between driver seat control unit harness connector and ground.

Driver seat control unit		Ground	Continuity
Connector	Terminal		
B451	6		Not existed
	5		

Is the inspection result normal?

YES >> Replace driver seat control unit. Refer to [ADP-201. "Removal and Installation"](#).

NO >> Repair or replace harness or connector.

A
B
C
D
E
F
G
H
I
K
L
M
N
O
P

ADP

LIFTING MOTOR (FRONT)

< DTC/CIRCUIT DIAGNOSIS >

LIFTING MOTOR (FRONT)

Description

INFOID:000000006258102

- The lifting motor (front) is installed to the seat cushion frame.
- The lifting motor (front) is activated with the driver seat control unit.
- The lifter (front) is moved upward/downward by changing the rotation direction of lifting motor (front).

Component Function Check

INFOID:000000006258103

1.CHECK FUNCTION

1. Select "SEAT LIFTER FR" in "Active test" mode with CONSULT-III.
2. Check the lifting motor (front) operation.

Test item		Description	
SEAT LIFTER FR	OFF	Seat lifting (front)	Stop
	UP		Upward
	DWN		Downward

Is the operation of relevant parts normal?

YES >> INSPECTION END

NO >> Perform diagnosis procedure. Refer to [ADP-106. "Diagnosis Procedure"](#).

Diagnosis Procedure

INFOID:000000006258104

1.CHECK LIFTING MOTOR (FRONT) POWER SUPPLY

1. Turn ignition switch OFF.
2. Disconnect lifting motor (front) connector.
3. Turn the ignition switch ON.
4. Perform "Active test" ("SEAT LIFTER FR") with CONSULT-III.
5. Check voltage between lifting motor (front) harness connector and ground.

(+)		(-)	Condition	Voltage (V) (Approx.)	
Lifting motor (front)					
Connector	Terminals				
B455	56	Ground	SEAT LIFTER FR	OFF	0
				UP	0
				DWN (down)	Battery voltage
	57			OFF	0
				UP	Battery voltage
				DWN (down)	0

Is the inspection result normal?

YES >> Replace lifting motor (front). (Built in seat cushion frame.)

NO >> GO TO 2.

2.CHECK LIFTING MOTOR (FRONT) CIRCUIT

1. Turn ignition switch OFF.
2. Disconnect driver seat control unit connector.
3. Check continuity between driver seat control unit harness connector and lifting motor (front) harness connector.

LIFTING MOTOR (FRONT)

< DTC/CIRCUIT DIAGNOSIS >

Driver seat control unit		Lifting motor (front)		Continuity
Connector	Terminal	Connector	Terminal	
B451	9	B455	56	Existed
	10		57	

4. Check continuity between driver seat control unit harness connector and ground.

Driver seat control unit		Ground	Continuity
Connector	Terminal		
B451	9		Not existed
	10		

Is the inspection result normal?

YES >> Replace driver seat control unit. Refer to [ADP-201. "Removal and Installation"](#).

NO >> Repair or replace harness or connector.

A
B
C
D
E
F
G
H
I
K
L
M
N
O
P

ADP

LIFTING MOTOR (REAR)

< DTC/CIRCUIT DIAGNOSIS >

LIFTING MOTOR (REAR)

Description

INFOID:000000006258105

- The lifting motor (rear) is installed to the seat cushion frame.
- The lifting motor (rear) is activated with the driver seat control unit.
- The seat lifter (rear) is moved upward/downward by changing the rotation direction of lifting motor (rear).

Component Function Check

INFOID:000000006258106

1.CHECK FUNCTION

1. Select "SEAT LIFTER RR" in "Active test" mode with CONSULT-III.
2. Check the lifting motor (rear) operation.

Test item		Description	
SEAT LIFTER RR	OFF	Seat lifting (rear)	Stop
	UP		Upward
	DWN		Downward

Is the operation of relevant parts normal?

YES >> INSPECTION END

NO >> Perform diagnosis procedure. Refer to [ADP-108. "Diagnosis Procedure"](#).

Diagnosis Procedure

INFOID:000000006258107

1.CHECK LIFTING MOTOR (REAR) POWER SUPPLY

1. Turn ignition switch OFF.
2. Disconnect lifting motor (rear) connector.
3. Turn the ignition switch ON.
4. Perform "Active test" ("SEAT LIFTER RR") with CONSULT-III
5. Check voltage between lifting motor (rear) harness connector and ground.

(+)		(-)	Condition	Voltage (V) (Approx.)	
Lifting motor (rear)					
Connector	Terminals				
B456	55	Ground	SEAT LIFTER RR	OFF	0
				UP	Battery voltage
				DWN (DOWN)	0
	54			OFF	0
				UP	0
				DWN (DOWN)	Battery voltage

Is the inspection result normal?

YES >> Replace lifting motor (rear). (Built in seat cushion frame.)

NO >> GO TO 2.

2.CHECK LIFTING MOTOR (REAR) CIRCUIT

1. Turn ignition switch OFF.
2. Disconnect driver seat control unit connector.
3. Check continuity between driver seat control unit harness connector and lifting motor (rear) harness connector.

LIFTING MOTOR (REAR)

< DTC/CIRCUIT DIAGNOSIS >

Driver seat control unit		Lifting motor (rear)		Continuity
Connector	Terminal	Connector	Terminal	
B451	8	B456	55	Existed
	7		54	

4. Check continuity between driver seat control unit harness connector and ground.

Driver seat control unit		Ground	Continuity
Connector	Terminal		
B451	8		Not existed
	7		

Is the inspection result normal?

YES >> Replace driver seat control unit. Refer to [ADP-201. "Removal and Installation"](#).

NO >> Repair or replace harness or connector.

A
B
C
D
E
F
G
H
I
K
L
M
N
O
P

ADP

TILT MOTOR

< DTC/CIRCUIT DIAGNOSIS >

TILT MOTOR

Description

INFOID:000000006258108

- The tilt motor is installed to the steering column assembly.
- The tilt motor is activated with the automatic drive positioner control unit.
- The steering column is tilted upward/downward by changing the rotation direction of tilt motor.

Component Function Check

INFOID:000000006258109

1.CHECK FUNCTION

1. Select "TILT MOTOR" in "Active test" mode with CONSULT-III.
2. Check the tilt motor operation.

Test item		Description	
TILT MOTOR	OFF	Steering tilt	Stop
	UP		Upward
	DWN		Downward

Is the operation of relevant parts normal?

YES >> INSPECTION END

NO >> Perform diagnosis procedure. Refer to [ADP-110, "Diagnosis Procedure"](#).

Diagnosis Procedure

INFOID:000000006258110

1.CHECK TILT MOTOR POWER SUPPLY

1. Turn ignition switch OFF.
2. Disconnect tilt motor connector.
3. Turn the ignition switch ON.
4. Perform "Active test" ("TILT MOTOR") with CONSULT-III.
5. Check voltage between tilt motor harness connector and ground.

(+)		(-)	Condition	Voltage (V) (Approx.)	
Tilt motor					
Connector	Terminals				
M116	1	Ground	TILT MOTOR	OFF	0
				UP	0
				DWN (down)	Battery voltage
	2			OFF	0
				UP	Battery voltage
				DWN (down)	0

Is the inspection result normal?

YES >> Replace tilt motor. (Built in steering column assembly.)

NO >> GO TO 2.

2.CHECK TILT MOTOR CIRCUIT

1. Turn ignition switch OFF.
2. Disconnect automatic drive positioner control unit.
3. Check continuity between automatic drive positioner control unit harness connector and tilt motor harness connector.

TILT MOTOR

< DTC/CIRCUIT DIAGNOSIS >

Automatic drive positioner control unit		Tilt motor		Continuity
Connector	Terminal	Connector	Terminal	
M104	28	M116	1	Existed
	29		2	

4. Check continuity between automatic drive positioner control unit harness connector and ground.

Automatic drive positioner control unit		Ground	Continuity
Connector	Terminal		
M104	28		Not existed
	29		

Is the inspection result normal?

YES >> Replace automatic drive positioner control unit. Refer to [ADP-202, "Removal and Installation"](#).

NO >> Repair or replace harness or connector.

A
B
C
D
E
F
G
H
I
K
L
M
N
O
P

ADP

TELESCOPIC MOTOR

< DTC/CIRCUIT DIAGNOSIS >

TELESCOPIC MOTOR

Description

INFOID:000000006258111

- The telescopic motor is installed to the steering column assembly.
- The telescopic motor is activated with the automatic drive positioner control unit.
- Compresses the steering column by changing the rotation direction of telescopic motor.

Component Function Check

INFOID:000000006258112

1. CHECK FUNCTION

1. Select "TELESCO MOTOR" in "Active test" mode with CONSULT-III.
2. Check the telescopic motor operation.

Test item		Description	
TELESCO MOTOR	OFF	Steering telescopic	Stop
	FR		Forward
	RR		Backward

Is the operation of relevant parts normal?

YES >> INSPECTION END

NO >> Perform diagnosis procedure. Refer to [ADP-112, "Diagnosis Procedure"](#).

Diagnosis Procedure

INFOID:000000006258113

1. CHECK TELESCOPIC MOTOR POWER SUPPLY

1. Turn ignition switch OFF.
2. Disconnect telescopic motor connector.
3. Turn the ignition switch ON.
4. Perform "Active test" ("TELESCO MOTOR") with CONSULT-III
5. Check voltage between telescopic motor harness connector and ground.

(+)		(-)	Condition	Voltage (V) (Approx.)	
Telescopic motor					
Connector	Terminals				
M117	1	Ground	TELESCOPIC MOTOR	OFF	0
				FR (forward)	0
				RR (backward)	Battery voltage
	2			OFF	0
				FR (forward)	Battery voltage
				RR (backward)	0

Is the inspection result normal?

YES >> Replace telescopic motor. (Built in steering column assembly.)

NO >> GO TO 2.

2. CHECK TELESCOPIC MOTOR CIRCUIT

1. Turn ignition switch OFF.
2. Disconnect automatic drive positioner control unit.
3. Check continuity between automatic drive positioner control unit harness connector and telescopic motor harness connector.

TELESCOPIC MOTOR

< DTC/CIRCUIT DIAGNOSIS >

Automatic drive positioner control unit		Telescopic motor		Continuity
Connector	Terminal	Connector	Terminal	
M75	29	M117	2	Existed
	26		1	

4. Check continuity between automatic drive positioner control unit harness connector and ground.

Automatic drive positioner control unit		Ground	Continuity
Connector	Terminal		
M75	29		Not existed
	26		

Is the inspection result normal?

YES >> Replace automatic drive positioner control unit. Refer to [ADP-202, "Removal and Installation"](#).

NO >> Repair or replace harness or connector.

A
B
C
D
E
F
G
H
I
K
L
M
N
O
P

ADP

DOOR MIRROR MOTOR

< DTC/CIRCUIT DIAGNOSIS >

DOOR MIRROR MOTOR

Description

INFOID:000000006258114

It makes mirror face operate from side to side and up and down with the electric power that AUTOMATIC DRIVE POSITIONER CONTROL UNIT supplies.

Component Function Check

INFOID:000000006258115

1. CHECK DOOR MIRROR MOTOR FUNCTION

Check the operation with "MIRROR MOTOR RH" and "MIRROR MOTOR LH" in "ACTIVE TEST" mode with CONSULT-III

Refer to [ADP-41, "CONSULT-III Function"](#).

Is the inspection result normal?

- YES >> Door mirror motor function is OK.
 NO >> Refer to [ADP-114, "Diagnosis Procedure"](#).

Diagnosis Procedure

INFOID:000000006258116

1. CHECK DOOR MIRROR MOTOR INPUT SIGNAL

- Turn ignition switch ON.
- Check voltage between door mirror connector and ground.

(+)		(-)	Condition	Voltage (V) (Approx.)	
Door mirror					
Connector	Terminals				
D3 (Driver side) D43 (Passenger side)	12	Ground	Door mirror remote control switch	UP	Battery voltage
				Other than above	0
	11			LEFT	Battery voltage
				Other than above	0
	10			DOWN / RIGHT	Battery voltage
				Other than above	0

Is the inspection result normal?

- YES >> GO TO 3.
 NO >> GO TO 2.

2. CHECK DOOR MIRROR MOTOR CIRCUIT

- Turn ignition switch OFF.
- Disconnect automatic drive positioner control unit connector and door mirror connector.
- Check continuity between automatic drive positioner control unit connector and door mirror connector.

[Door mirror driver side]

Automatic drive positioner control unit		Door mirror (driver side)		Continuity
Connector	Terminal	Connector	Terminal	
M75	12	D3	10	Existed
	23		12	
	24		11	

[Door mirror passenger side]

Automatic drive positioner control unit		Door mirror (passenger side)		Continuity
Connector	Terminal	Connector	Terminal	
M75	22	D43	10	Existed
	10		12	
	11		11	

DOOR MIRROR MOTOR

< DTC/CIRCUIT DIAGNOSIS >

4. Check continuity between automatic drive positioner control unit connector and ground.

[Door mirror driver side]

Automatic drive positioner control unit		Ground	Continuity
Connector	Terminal		
M75	12		Not existed
	23		
	24		

[Door mirror passenger side]

Automatic drive positioner control unit		Ground	Continuity
Connector	Terminal		
M75	22		Not existed
	10		
	11		

Is the inspection result normal?

YES >> Replace automatic drive positioner control unit. Refer to [ADP-202, "Removal and Installation"](#).

NO >> Repair or replace harness or connector.

3.CHECK DOOR MIRROR MOTOR

Check door mirror motor.

Refer to [ADP-115, "Component Inspection"](#).

Is the inspection result normal?

YES >> Check intermittent incident. Refer to [GI-44, "Intermittent Incident"](#).

NO >> Replace door mirror. Refer to [MIR-71, "DOOR MIRROR ASSEMBLY : Removal and Installation"](#).

Component Inspection

INFOID:000000006258117

1.CHECK DOOR MIRROR MOTOR-I

Check that door mirror motor does not trap foreign objects and does not have any damage.

Refer to [MIR-70, "DOOR MIRROR ASSEMBLY : Exploded View"](#).

Is the inspection result normal?

YES >> GO TO 2.

NO >> Replace door mirror. Refer to [MIR-71, "DOOR MIRROR ASSEMBLY : Removal and Installation"](#).

2.CHECK DOOR MIRROR MOTOR-II

1. Turn ignition switch OFF.
2. Disconnect door mirror connector.
3. Apply 12V to each power supply terminal of door mirror motor.

Connector	Door mirror		Operational direction
	(+)	(-)	
D3 (Driver side) D43 (Passenger side)	10	11	RIGHT
	11	10	LEFT
	12	10	UP
	10	12	DOWN

Is the inspection result normal?

YES >> INSPECTION END

NO >> Replace door mirror. Refer to [MIR-71, "DOOR MIRROR ASSEMBLY : Removal and Installation"](#).

SEAT MEMORY INDICATOR

< DTC/CIRCUIT DIAGNOSIS >

SEAT MEMORY INDICATOR

Description

INFOID:000000006258118

- Memory switch is equipped on the seat memory switch installed to the driver side door trim. The operation signal is inputted to the driver seat control unit when the memory switch is operated.
- The status of automatic drive positioner system can be checked according to the illuminating/flashing status.

Component Function Check

INFOID:000000006258119

1. CHECK FUNCTION

1. Select "MEMORY SW INDCTR" in "Active test" mode with CONSULT-III.
2. Check the memory indicator operation.

Test item		Description	
MEMORY SW INDCTR	OFF	Memory switch indicator	OFF
	ON-1		Indicator 1: ON
	ON-2		Indicator 2: ON

Is the operation of relevant parts normal?

YES >> INSPECTION END

NO >> Perform diagnosis procedure. Refer to [ADP-116, "Diagnosis Procedure"](#).

Diagnosis Procedure

INFOID:000000006258120

1. CHECK SEAT MEMORY INDICATOR OPERATION

Check seat memory indicator operation.

Which is the malfunctioning indicator?

All indicators are NG>>GO TO 2.

An indicator is NG>>GO TO 4.

2. CHECK FUSE

1. Turn ignition switch OFF.
2. Check that the blown fuse after repairing the affected circuit if a fuse is blown.

Signal name	Fuse No.
Battery power supply	10 (10A)

Is the fuse blown?

YES >> Replace the blown fuse after repairing the affected circuit if a fuse is blown.

NO >> GO TO 3.

3. CHECK MEMORY INDICATOR POWER SUPPLY

Check voltage between seat memory switch harness connector and ground.

(+)		(-)	Voltage (V) (Approx.)
Seat memory switch			
Connector	Terminals	Ground	Battery voltage
D13	5		

Is the inspection result normal?

YES >> Replace seat memory switch. Refer to [ADP-203, "Removal and Installation"](#).

NO >> Repair or replace harness or connector.

4. CHECK MEMORY INDICATOR CIRCUIT

1. Turn ignition switch OFF.
2. Disconnect driver seat control unit and seat memory switch connector.

SEAT MEMORY INDICATOR

< DTC/CIRCUIT DIAGNOSIS >

3. Check continuity between driver seat control unit harness connector and seat memory switch harness connector.

Driver seat control unit		Seat memory switch		Continuity
Connector	Terminal	Connector	Terminal	
B452	25	D13	6	Existed
	26		7	

4. Check continuity between driver seat control unit harness connector and ground.

Driver seat control unit		Ground	Continuity
Connector	Terminal		
B452	25		Not existed
	26		

Is the inspection result normal?

- YES >> Replace driver seat control unit. Refer to [ADP-201, "Removal and Installation"](#).
 NO >> Repair or replace harness or connector.

A
B
C
D
E
F
G
H
I
K
L
M
N
O
P

ADP

DRIVER SEAT CONTROL UNIT

< ECU DIAGNOSIS INFORMATION >

ECU DIAGNOSIS INFORMATION

DRIVER SEAT CONTROL UNIT

Reference Value

INFOID:000000006258121

VALUES ON THE DIAGNOSIS TOOL

CONSULT-III MONITOR ITEM

Monitor Item	Condition	Value/Status	
SET SW	Set switch	Push	ON
		Release	OFF
MEMORY SW1	Memory switch 1	Push	ON
		Release	OFF
MEMORY SW2	Memory switch 2	Push	ON
		Release	OFF
SLIDE SW-FR	Sliding switch (forward)	Operate	ON
		Release	OFF
SLIDE SW-RR	Sliding switch (backward)	Operate	ON
		Release	OFF
RECLN SW-FR	Reclining switch (forward)	Operate	ON
		Release	OFF
RECLN SW-RR	Reclining switch (backward)	Operate	ON
		Release	OFF
LIFT FR SW-UP	Lifting switch front (up)	Operate	ON
		Release	OFF
LIFT FR SW-DN	Lifting switch front (down)	Operate	ON
		Release	OFF
LIFT RR SW-UP	Lifting switch rear (up)	Operate	ON
		Release	OFF
LIFT RR SW-DN	Lifting switch rear (down)	Operate	ON
		Release	OFF
MIR CON SW-UP	Mirror switch	Up	ON
		Other than above	OFF
MIR CON SW-DN	Mirror switch	Down	ON
		Other than above	OFF
MIR CON SW-RH	Mirror switch	Right	ON
		Other than above	OFF
MIR CON SW-LH	Mirror switch	Left	ON
		Other than above	OFF
MIR CHNG SW-R	Changeover switch	Right	ON
		Other than above	OFF
MIR CHNG SW-L	Changeover switch	Left	ON
		Other than above	OFF
TILT SW-UP	Tilt switch	Upward	ON
		Other than above	OFF
TILT SW-DOWN	Tilt switch	Downward	ON
		Other than above	OFF

DRIVER SEAT CONTROL UNIT

< ECU DIAGNOSIS INFORMATION >

Monitor Item	Condition		Value/Status
TELESCO SW-FR	Telescopic switch	Forward	ON
		Other than above	OFF
TELESCO SW-RR	Telescopic switch	Backward	ON
		Other than above	OFF
DETENT SW	A/T selector lever	P position	OFF
		Other than above	ON
STARTER SW	Ignition position	Cranking	ON
		Other than above	OFF
SLIDE PULSE	Seat sliding	Forward	The numeral value decreases *
		Backward	The numeral value increases*
		Other than above	No change to numeral value*
RECLN PULSE	Seat reclining	Forward	The numeral value decreases*
		Backward	The numeral value increases *
		Other than above	No change to numeral value *
LIFT FR PULSE	Seat lifter (front)	Up	The numeral value decreases *
		Down	The numeral value increases *
		Other than above	No change to numeral value *
LIFT RR PULSE	Seat lifter (rear)	Up	The numeral value decreases *
		Down	The numeral value increases *
		Other than above	No change to numeral value *
MIR/SEN RH U-D	Door mirror (passenger side)		Change between 3.4 (close to peak) 0.6 (close to valley)
MIR/SEN RH R-L	Door mirror (passenger side)		Change between 3.4 (close to left edge) 0.6 (close to right edge)
MIR/SEN LH U-D	Door mirror (driver side)		Change between 3.4 (close to peak) 0.6 (close to valley)
MIR/SEN LH R-L	Door mirror (driver side)		Change between 0.6 (close to left edge) 3.4 (close to right edge)
TILT PULSE	Tilt position	Upward	The numeral value decreases *
		Downward	The numeral value increases *
		Other than above	No change to numeral value *
TELESCO PULSE	Telescopic position	Forward	The numeral value decreases *
		Backward	The numeral value increases *
		Other than above	No change to numeral value *
STEERING STATUS	NOTE: This item is displayed, but cannot be monitored		
VEHICLE SPEED	The condition of vehicle speed is displayed		km/h
P RANG SW CAN	A/T selector lever	P position	ON
		Other than above	OFF
R RANGE (CAN)	A/T selector lever	R position	ON
		Other than above	OFF
DOOR SW-FL	Driver door	Open	ON
		Close	OFF

A
B
C
D
E
F
G
H
I
K
L
M
N
O
P

ADP

DRIVER SEAT CONTROL UNIT

< ECU DIAGNOSIS INFORMATION >

Monitor Item	Condition		Value/Status
DOOR SW-FR	Passenger door	Open	ON
		Close	OFF
IGN ON SW	Ignition switch	ON position	ON
		Other than above	OFF
ACC ON SW	Ignition switch	ACC or ON position	ON
		Other than above	OFF
KEY ON SW	Intelligent Key	Inserted is key slot	ON
		Inserted is not key slot	OFF
KEYLESS ID	UNLOCK button of Intelligent Key is pressed		1,2,3,4or5
KYL5 DR UNLK	Intelligent Key or driver side door request switch	ON	ON
		OFF	OFF
VHCL SPEED (ABS)	Can signal from ABS	Received	ON
		Not received	OFF
HANDLE	The BCM for handle position is displayed		LHD
			RHD
TRANSMISSION	Transmission type is displayed		AT or CVT
			MT

*: The value at the position attained when the battery is connected is regarded as 32768.

TERMINAL LAYOUT

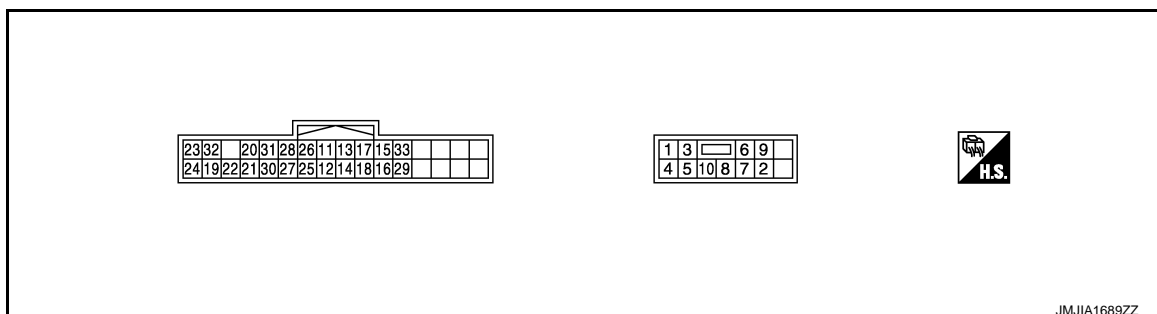

PHYSICAL VALUES

Terminal No. (wire color)		Description		Condition	Voltage (V) (Approx)	
+	-	Signal name	Input/ Output			
1 (R)	Ground	Power source	Input	—	Battery voltage	
2 (B)	Ground	Ground (power)	—	—	0	
3 (G)	Ground	Sliding motor backward output signal	Output	Seat sliding	Operate (backward)	Battery voltage
					Stop	0
4 (G/R)	Ground	Sliding motor forward output signal	Output	Seat sliding	Operate (forward)	Battery voltage
					Release	0
5 (V)	Ground	Reclining motor backward output signal	Output	Seat reclining	Operate (backward)	Battery voltage
					Stop	0

DRIVER SEAT CONTROL UNIT

< ECU DIAGNOSIS INFORMATION >

Terminal No. (wire color)		Description		Condition		Voltage (V) (Approx)
+	-	Signal name	Input/ Output			
6 (R/L)	Ground	Reclining motor forward output signal	Output	Seat reclining	Operate (forward)	Battery voltage
					Release	0
7 (L)	Ground	Lifting motor (rear) down output signal	Output	Seat lifting (rear)	Operate (down)	Battery voltage
					Stop	0
8 (L/W)	Ground	Lifting motor (rear) up output signal	Output	Seat lifting (rear)	Operate (up)	Battery voltage
					Stop	0
9 (L/R)	Ground	Lifting motor (front) down output signal	Output	Seat lifting (front)	Operate (down)	Battery voltage
					Stop	0
10 (L/B)	Ground	Lifting motor (front) up output signal	Output	Seat lifting (front)	Operate (up)	Battery voltage
					Stop	0
11 (G/B)	Ground	Sliding switch backward signal	Input	Sliding switch	Operate (backward)	0
					Release	Battery voltage
12 (G/W)	Ground	Sliding switch forward signal	Input	Sliding switch	Operate (forward)	0
					Release	Battery voltage
13 (R/G)	Ground	Reclining switch backward signal	Input	Reclining switch	Operate (backward)	0
					Release	Battery voltage
14 (R/W)	Ground	Reclining switch forward signal	Input	Reclining switch	Operate (forward)	0
					Release	Battery voltage
15 (Y/B)	Ground	Lifting switch (rear) down signal	Input	Lifting switch (rear)	Operate (down)	0
					Release	Battery voltage
16 (Y/R)	Ground	Lifting switch (rear) up signal	Input	Seat lifting switch (rear)	Operate (up)	0
					Release	Battery voltage
17 (LG/B)	Ground	Lifting switch (front) down signal	Input	Lifting switch (front)	Operate (down)	0
					Release	Battery voltage
18 (LG/R)	Ground	Lifting switch (front) up signal	Input	Seat lifting switch (front)	Operate (up)	0
					Release	Battery voltage
19 (G/Y)	Ground	Sliding sensor signal	Input	Seat sliding	Operate	
					Stop	0 or 5

A
B
C
D
E
F
G
H
I
ADP
K
L
M
N
O
P

DRIVER SEAT CONTROL UNIT

< ECU DIAGNOSIS INFORMATION >

Terminal No. (wire color)		Description		Condition		Voltage (V) (Approx)
+	-	Signal name	Input/ Output			
20 (R/Y)	Ground	Reclining sensor signal	Input	Seat reclining	Operate	
					Stop	0 or 5
21 (L/Y)	Ground	Lifting sensor (rear) signal	Input	Seat lifting (rear)	Operate	
					Stop	0 or 5
22 (BR/Y)	Ground	Lifting sensor (front) signal	Input	Seat lifting (front)	Operate	
					Stop	0 or 5
23 (P)	—	CAN-H	—	—	—	—
24 (P/L)	—	CAN-L	—	—	—	—
25 (G/O)	Ground	Memory indicator 1 signal	Output	Memory indicator 1	Illuminate	1
					Other than above	Battery voltage
26 (L/O)	Ground	Memory indicator 2 signal	Output	Memory indicator 2	Illuminate	1
					Other than above	Battery voltage
27 (V)	Ground	Memory switch 1 signal	Input	Memory switch 1	Press	0
					Other than above	5
28 (V/W)	Ground	Memory switch 2 signal	Input	Memory switch 2	Press	0
					Other than above	5
29 (O/L)	Ground	Set switch signal	Input	Set switch	Press	0
					Other than above	5
30 (BR)	Ground	Tilt sensor signal	Input	Tilt	Operate	
					Other than above	0 or 5

DRIVER SEAT CONTROL UNIT

< ECU DIAGNOSIS INFORMATION >

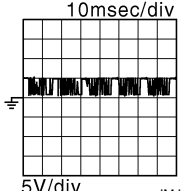
Terminal No. (wire color)		Description		Condition	Voltage (V) (Approx)
+	-	Signal name	Input/ Output		
31 (BR/W)	Ground	Telescopic sensor signal	Input	Telescopic	Operate
					Other than above
32 (W/L)	Ground	UART communication (TX/RX)	Input	Ignition switch ON	
					
33 (W)	Ground	Sensor power supply	Output	—	Battery voltage

A
B
C
D
E
F
G
H
I
K
L
M
N
O
P

ADP

DRIVER SEAT CONTROL UNIT

< ECU DIAGNOSIS INFORMATION >

Wiring Diagram - AUTOMATIC DRIVE POSITIONER CONTROL SYSTEM -

INFOID:000000006258122

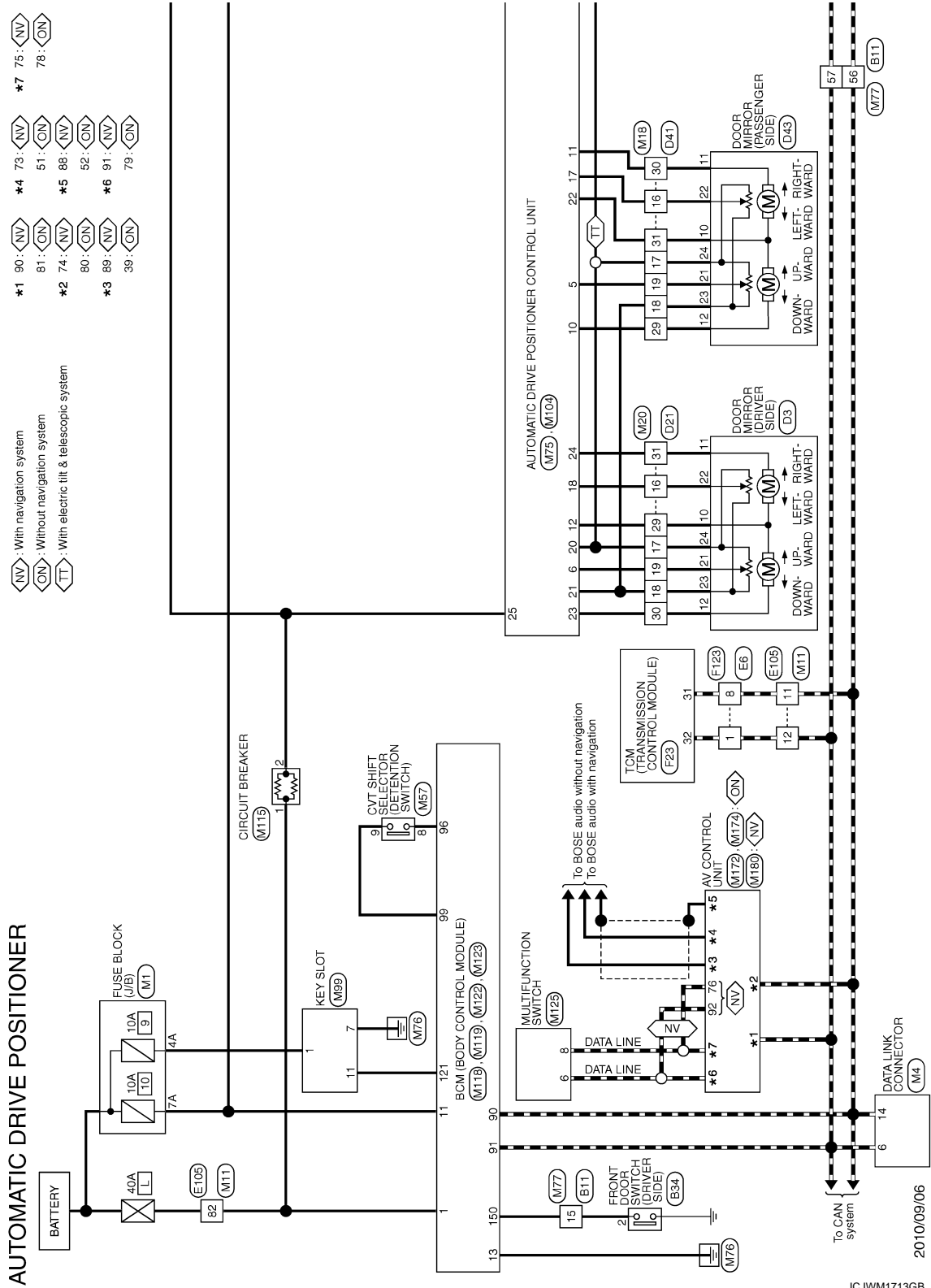

2010/09/06

JCJWM1713GB

DRIVER SEAT CONTROL UNIT

< ECU DIAGNOSIS INFORMATION >

Ⓣ : With electric tilt & telescopic system

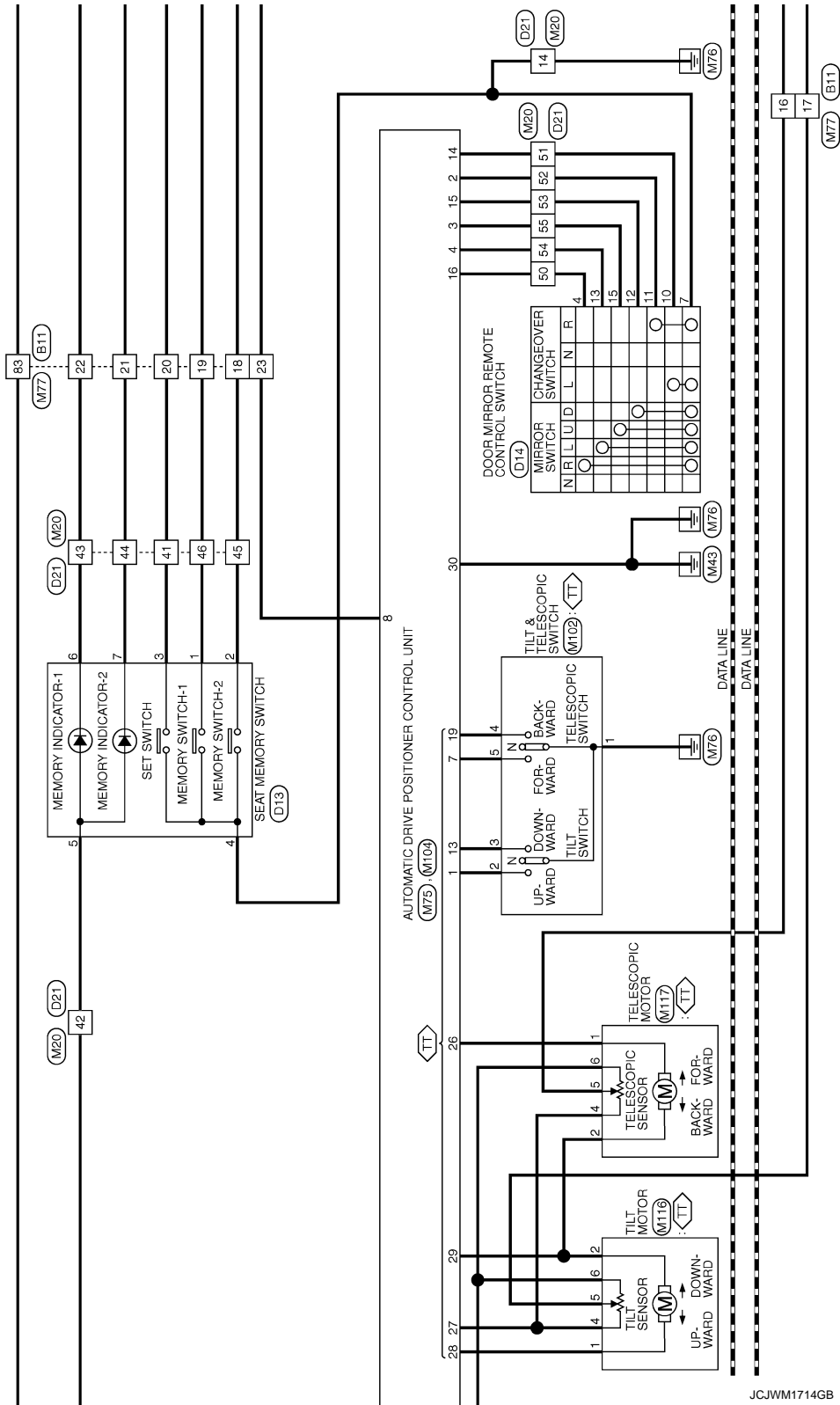

A
B
C
D
E
F
G
H
I
ADP
K
L
M
N
O
P

DRIVER SEAT CONTROL UNIT

< ECU DIAGNOSIS INFORMATION >

 : With electric tilt & telescopic system
 * : This connector is not shown in "Harness Layout".

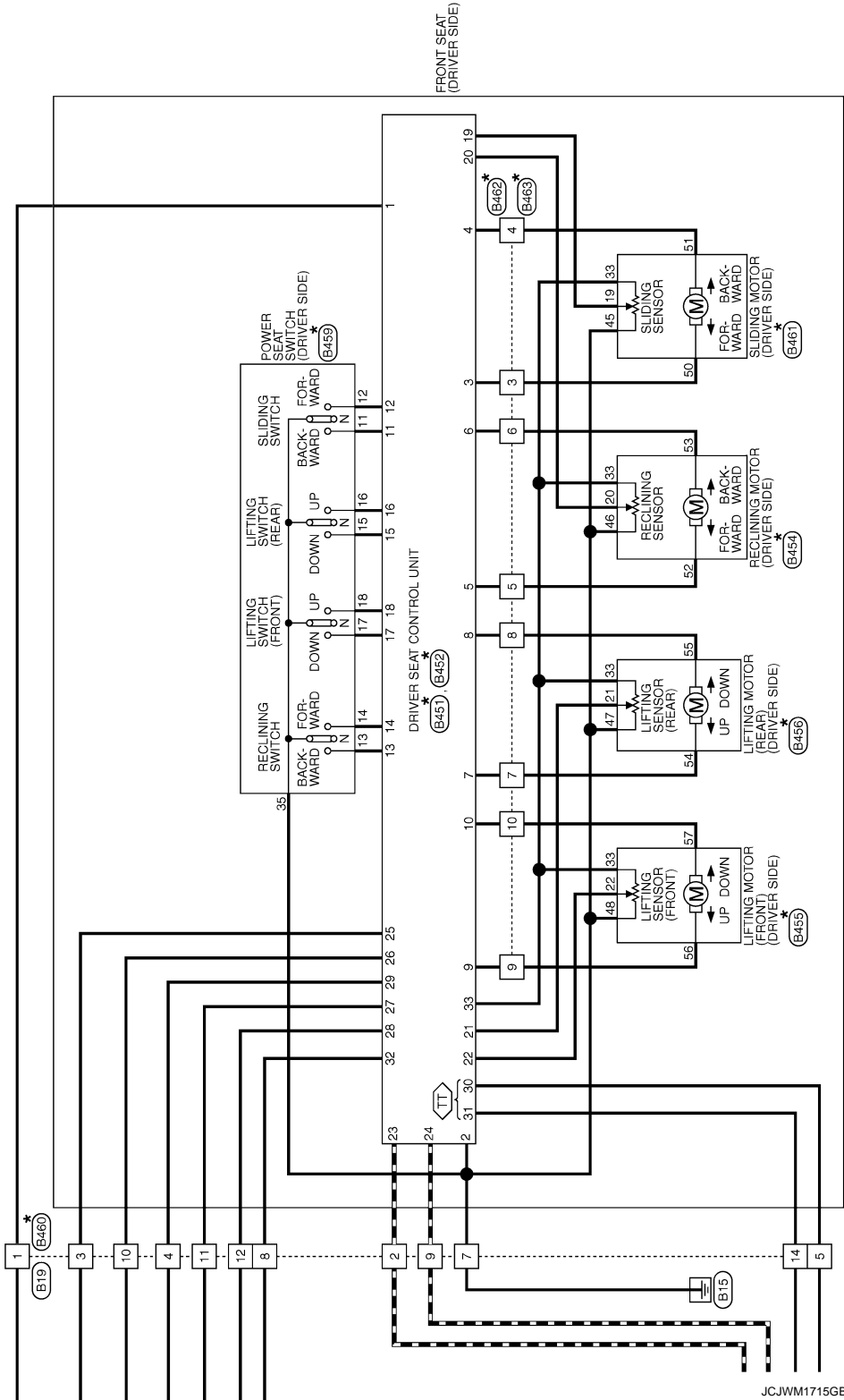

JCJWM1715GB

DRIVER SEAT CONTROL UNIT

< ECU DIAGNOSIS INFORMATION >

AUTOMATIC DRIVE POSITIONER

Connector No.	B11
Connector Name	WIRE TO WIRE
Connector Type	TH80MW-CS-9

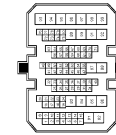

Terminal No.	Color of Wire	Signal Name [Specification]
1	SHIELD	-
2	B	-
3	R/L	-
4	R/W	-
5	SB	-
6	P	-
7	V	-
8	SHIELD	-
9	BR/L	-
10	Y/G	-
11	Y/L	-
12	W/L	-
13	L	-
14	BR	-
15	SB	-
16	BR	-
17	V	-
18	SB	-
19	R	-
20	P	-
21	LG	-
22	W	-
23	Y	-
24	GR	-
25	Y	-
27	V	-
28	W/L	-
30	P	-
31	O	-
32	BR	-
34	SB	-
35	SHIELD	-
36	L/O	-
37	LG	-
40	Y	-
41	GR	-
42	SB	-
46	LG	-

Connector No.	B19
Connector Name	WIRE TO WIRE
Connector Type	MS16FW-CS

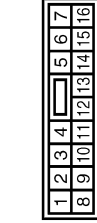

Terminal No.	Color of Wire	Signal Name [Specification]
1	BR	-
2	L	-
3	W	-
4	P	-
5	V	-
6	GR	-
7	B	-
8	Y	-
9	P	-
10	LG	-
11	R	-
12	SB	-
13	O	-
14	BR	-
15	G	-
16	B/W	-

Connector No.	B34
Connector Name	FRONT DOOR SWITCH (DRIVER SIDE)
Connector Type	A03FW

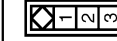

Terminal No.	Color of Wire	Signal Name [Specification]
2	SB	-

Connector No.	B451
Connector Name	DRIVER SEAT CONTROL UNIT
Connector Type	MS12FW-CS

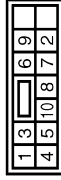

Terminal No.	Color of Wire	Signal Name [Specification]
1	R	-
2	B	-
3	G	-
4	G/R	-
5	V	-
6	R/L	-
7	L	-
8	L/W	-
9	L/R	-
10	L/B	-

A
B
C
D
E
F
G
H
I
K
L
M
N
O
P

ADP

DRIVER SEAT CONTROL UNIT

< ECU DIAGNOSIS INFORMATION >

AUTOMATIC DRIVE POSITIONER

Connector No.	B452
Connector Name	DRIVER SEAT CONTROL UNIT
Connector Type	TH227W

Terminal No.	23	24	19	22	21	30	27	25	12	14	18	16	29
Color of Wire	B	W	Y	R	G	B	W	Y	R	G	B	W	Y
Signal Name [Specification]													

Terminal No.	Color of Wire	Signal Name [Specification]
11	G/B	-
12	G/W	-
13	R/G	-
14	R/W	-
15	Y/B	-
16	Y/R	-
17	LC/B	-
18	LC/R	-
19	G/Y	-
20	R/Y	-
21	L/Y	-
22	BR/Y	-
23	P	-
24	P/L	-
25	G/O	-
26	L/O	-
27	V	-
28	V/W	-
29	O/L	-
30	BR	-
31	BR/W	-
32	W/L	-
33	W	-

Connector No.	B454
Connector Name	RECLINING MOTOR (DRIVER SIDE)
Connector Type	F 6098-0344

Terminal No.	53	52	33	46	20
Color of Wire	B	W	Y	R	G
Signal Name [Specification]					

Terminal No.	20	32	46	32	53
Color of Wire	R/Y	W	B/W	V	R/L
Signal Name [Specification]					

Connector No.	B455
Connector Name	LIFTING MOTOR (FRONT) (DRIVER SIDE)
Connector Type	F 6098-0344

Terminal No.	57	56	33	48	22
Color of Wire	BR/Y	W	P/B	L/R	L/B
Signal Name [Specification]					

Terminal No.	Color of Wire	Signal Name [Specification]
22	BR/Y	-
33	W	-
48	P/B	-
56	L/R	-
57	L/B	-

Connector No.	B456
Connector Name	LIFTING MOTOR (REAR) (DRIVER SIDE)
Connector Type	F 6098-0344

Terminal No.	55	54	33	47	21
Color of Wire	L/W	-	-	-	-
Signal Name [Specification]					

Connector No.	B459
Connector Name	POWER SEAT SWITCH (DRIVER SIDE)
Connector Type	NS10FW-CS

Terminal No.	35	13	14	11	12	17	18
Color of Wire	B	W	Y	R	G	B	W
Signal Name [Specification]							

Terminal No.	Color of Wire	Signal Name [Specification]
11	G/B	-
12	G/W	-
13	R/G	-
14	R/W	-
15	Y/B	-
16	Y/R	-
17	LC/B	-
18	LC/R	-
35	B	-

Connector No.	B460
Connector Name	WIRE TO WIRE
Connector Type	NS16MW-CS

Terminal No.	7	6	5	16	15	14	13	12	11	10	9	8
Color of Wire	B	W	Y	R	G	B	W	Y	R	G	B	W
Signal Name [Specification]												

Terminal No.	Color of Wire	Signal Name [Specification]
1	R	-
2	P	-
3	G/O	-
4	O/L	-
5	BR	-
6	W/G	-
7	B	-
8	W/L	-
9	P/L	-
10	L/O	-
11	V	-
12	V/W	-
13	W/R	-

Terminal No.	14	15	16
Color of Wire	BR/W	B/R	GR
Signal Name [Specification]			

Connector No.	B461
Connector Name	SLIDING MOTOR (DRIVER SIDE)
Connector Type	F 6098-0344

Terminal No.	51	33	45	19	60
Color of Wire	B	W	Y	R	G
Signal Name [Specification]					

Terminal No.	Color of Wire	Signal Name [Specification]
19	G/Y	-
33	W	-
45	W/B	-
50	G	-
51	G/R	-

Connector No.	B462
Connector Name	WIRE TO WIRE
Connector Type	NS10MW-CS

Terminal No.	8	7	38	69	10	9	4	13	16	15
Color of Wire	B	W	Y	R	G	B	W	Y	R	G
Signal Name [Specification]										

Terminal No.	Color of Wire	Signal Name [Specification]
3	G	-
4	G/R	-
5	V	-
6	R/L	-
7	L	-
8	L/W	-
9	L/R	-
10	L/B	-
38	Y/W	-
39	Y	-

DRIVER SEAT CONTROL UNIT

< ECU DIAGNOSIS INFORMATION >

AUTOMATIC DRIVE POSITIONER

Connector No.	B463
Connector Name	WIRE TO WIRE
Connector Type	MS10PW-CS

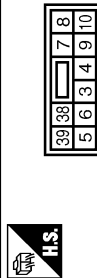

Terminal No.	Color of Wire	Signal Name [Specification]
3	G	-
4	G/R	-
5	V	-
6	R/L	-
7	L/W	-
8	L/R	-
10	L/B	-
38	Y/W	-
39	Y	-

Connector No.	D3
Connector Name	DOOR MIRROR (DRIVER SIDE)
Connector Type	TH24MW-NH

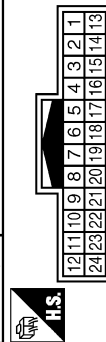

Terminal No.	Color of Wire	Signal Name [Specification]
7	LG	-
10	V	-
11	BR	-
12	SB	-
19	B	-
21	BR	-
22	G	-
23	GR	-
24	Y	-

Connector No.	D13
Connector Name	SEAT MEMORY SWITCH
Connector Type	A08FW

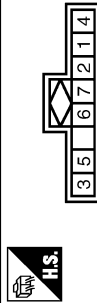

Terminal No.	Color of Wire	Signal Name [Specification]
1	R	-
2	G	-
3	P	-
4	B	-
5	GR	-
6	L	-
7	W	-

Connector No.	D14
Connector Name	DOOR MIRROR REMOTE CONTROL SWITCH
Connector Type	TK18FBR

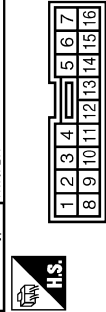

Terminal No.	Color of Wire	Signal Name [Specification]
4	V	-
7	B	-
8	Y	-
9	L	-
10	O	-
11	P	-
12	L	-
13	SB	-
15	LG	-

Connector No.	B21
Connector Name	WIRE TO WIRE
Connector Type	TH40FW-CS15

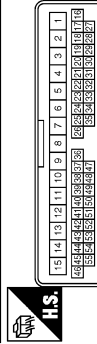

Terminal No.	Color of Wire	Signal Name [Specification]
1	V	-
2	G	-
3	P	-
4	B	-
5	W	-
6	SB	-
7	P	-
8	BR	-
9	GR	-
10	V	-
11	O	-
14	B	-
15	LG	-
16	G	-
17	Y	-
18	GR	-
19	BR	-
20	LG	-
24	P	-
25	V	-
26	W	-
28	V	-
30	SB	-
31	BR	-
32	R	-
33	G	-
34	Y	-
35	L	-
41	P	-
42	GR	-
43	L	-
44	W	-
45	SB	-
46	R	-
50	V	-
51	O	-
52	P	-
53	L	-

53	L	- [With automatic drive positioner]
53	P	- [Without automatic drive positioner]
54	SB	- [With automatic drive positioner]
54	LG	- [Without automatic drive positioner]
55	LG	- [With automatic drive positioner]
55	O	- [Without automatic drive positioner]

Connector No.	D41
Connector Name	WIRE TO WIRE
Connector Type	TH40FW-CS15

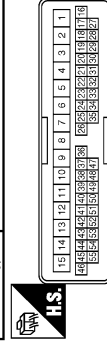

Terminal No.	Color of Wire	Signal Name [Specification]
1	G	-
2	V	-
4	B	-
5	W	-
6	P	-
7	O	-
8	B	-
16	G	-
17	Y	-
18	GR	-
19	BR	-
20	LG	-
24	LG	-
25	W	-
26	O	-
29	V	-
30	SB	-
31	BR	-
32	R	-
33	G	-
34	Y	-
35	L	-

A
B
C
D
E
F
G
H
I
J
K
L
M
N
O
P

ADP

DRIVER SEAT CONTROL UNIT

< ECU DIAGNOSIS INFORMATION >

AUTOMATIC DRIVE POSITIONER

Connector No.	D43
Connector Name	DOOR MIRROR (PASSENGER SIDE)
Connector Type	TH2AMV-NH



Terminal No.	Color of Wire	Signal Name [Specification]
7	LG	-
10	BR	-
11	SB	-
12	V	-
18	B	-
21	BR	-
22	G	-
23	GR	-
24	Y	-

Connector No.	E5
Connector Name	WIRE TO WIRE
Connector Type	TK6MGY-IV



Terminal No.	Color of Wire	Signal Name [Specification]
1	L	-
3	Y	-
4	R	-
5	GR	-
6	V	-
8	P	-
10	W	-
11	G	-
12	BR	-
13	SB	-
14	B	-

Connector No.	E105
Connector Name	WIRE TO WIRE
Connector Type	TH70MH-SS0-M3



Terminal No.	Color of Wire	Signal Name [Specification]
3	Y	-
5	LG	-
6	GR	-
8	G	-
11	P	-
12	L	-
13	Y	-
14	O	-
15	BR	-
20	Y	-
21	BR	-
22	P	-
24	L	-
25	O	-
28	SB	-
29	W	-
30	Y	-
47	P	-
48	L	-
49	SB	-
50	GR	-
51	LG	-
52	V	-
53	GR	-
54	BR	-
55	Y	-
56	W/L	-
60	V	-
61	BR	-
62	O	-
63	L/O	-
64	SHIELD	-
66	W	-
67	BR	-
68	Y	-
69	SB	-
70	GR	-
71	SB	-

72	Y	-
73	L	-
74	W	-
75	BR	-
76	GR	-
77	O	-
78	Y	- [With navigation system]
78	G	- [With iPod without navigation system]
78	V	- [Without iPod and navigation system]
79	Y	-
80	R	-
81	W	-
82	LG	-
83	O	-

Connector No.	F23
Connector Name	TCM (TRANSMISSION CONTROL MODULE)
Connector Type	RM40FB-R2B-L-RH

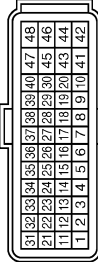

Terminal No.	Color of Wire	Signal Name [Specification]
1	P/B	INH SW 2
2	P/L	INH SW 3
3	G/O	INH SW 4
4	GR	INH SW 3 MON
5	B	GND
7	W	SENSOR GND
8	G/W	CLOCK (SEL 2)
9	L/R	CHP SELECT (SEL 1)
10	BR/R	DATA I/O (SEL 3)
11	BR/W	INH SW 1
13	V	ATF TEMP SENSOR
14	R/W	PRI PRESS SENSOR
15	V/W	SEC PRESS SENSOR
19	G/B	REV LAMP RELAY
20	R/B	STARTER RELAY
25	W/R	SENSOR GND
26	L/O	SENSOR POWER SOURCE (GV)
27	R/G	S/M-D
28	R	S/M-C
29	O/B	S/M-B
30	G/R	S/M-A
31	P	CAN-L

32	L	CAN-H
33	LG	PRI SPEED SENSOR
34	LG/R	SEC SPEED SENSOR
37	V/R	L/U 8 SEL-ON/OFF SOL
38	L/W	L/U 8 SEL LINEAR SOL
39	W/B	SEC LINEAR SOL
40	R/Y	PL LINEAR SOL
42	B	GND
46	Y	VIGN
47	L/R	BATT
48	Y	VIGN

Connector No.	F123
Connector Name	WIRE TO WIRE
Connector Type	TK16FGY-IV



Terminal No.	Color of Wire	Signal Name [Specification]
1	L	-
3	G/R	-
4	G/B	-
5	R	-
6	L/R	-
8	P	-
10	Y/B	-
11	BR/W	-
12	BR	-
13	G	-
14	B	-

DRIVER SEAT CONTROL UNIT

< ECU DIAGNOSIS INFORMATION >

AUTOMATIC DRIVE POSITIONER

Connector No.	M1
Connector Name	FUSE BLOCK (J/B)
Connector Type	NS8FV-M2



Terminal No.	Color of Wire	Signal Name [Specification]
1A	Y	-
2A	G	-
3A	Y	-
4A	GR	-
5A	R	-
6A	W	-
7A	LG	-
8A	Y	-

Connector No.	M4
Connector Name	DATA LINK CONNECTOR
Connector Type	BD16FV

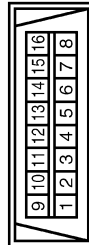

Terminal No.	Color of Wire	Signal Name [Specification]
3	LG	-
4	B	-
5	B	-
6	L	-
7	O	-
8	G	-
11	SB	-
14	P	-
16	Y	-

Connector No.	M11
Connector Name	WIRE TO WIRE
Connector Type	TH7DFV-CS10-M3



Terminal No.	Color of Wire	Signal Name [Specification]
3	P	-
5	O	-
6	G	-
8	R	-
11	P	-
12	L	-
13	V	-
14	Y	-
15	R	-
20	Y	-
21	BR	-
22	G	-
24	Y	-
25	L	-
28	BR	-
29	L	-
30	R	-
47	P	-
48	L	-
49	W	-
50	GR	-
51	LG	-
52	LG	-
53	V	-
54	SB	-
55	P	-
56	SB	-
60	V	-
61	GR	-
62	O	-
63	V	-
64	SHIELD	-
66	W	-
67	R	-
68	W	-
69	P	-
70	G	-
71	G	-

72	BR	-
73	L	-
74	W	-
75	BR	-
76	R	-
77	G	-
78	Y	-
79	G	-
80	R	-
81	W	-
82	W	-
83	O	-

Connector No.	M18
Connector Name	WIRE TO WIRE
Connector Type	TH40MW-CS15

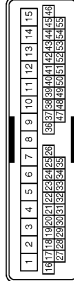

Terminal No.	Color of Wire	Signal Name [Specification]
1	G	-
2	V	-
4	L	- [With iPod without BOSE system]
4	W	- [With BOSE system and base audio without iPod]
5	B	- [With BOSE system]
5	W	- [With iPod without BOSE system]
5	BR	- [Without iPod and BOSE system]
8	GR	-
7	G	-
7	B	-
8	W	-
16	W	-
17	Y	-
18	W	-
19	R	-
20	SB	-
24	LG	-
25	Y	-
26	P	-
29	O	-
30	G	-
31	V	-
32	Y	-
33	P	-
34	BR	-

35	R	-
----	---	---

A
B
C
D
E
F
G
H
I
ADP
K
L
M
N
O
P

DRIVER SEAT CONTROL UNIT

< ECU DIAGNOSIS INFORMATION >

AUTOMATIC DRIVE POSITIONER

Connector No.	M20
Connector Name	WIRE TO WIRE
Connector Type	TH40MW-CS15

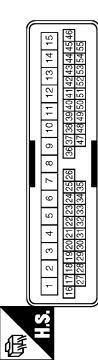

Terminal No.	Color of Wire	Signal Name [Specification]
1	V	-
2	G	-
3	W	-
4	R	- [With iPod without BOSE system]
4	B	- [With BOSE system and base audio without iPod]
5	G	- [With iPod without BOSE system]
5	C	- [With BOSE system and base audio without iPod]
6	L	- [With BOSE system and base audio without iPod]
6	V	-
7	BR	-
8	O	-
9	SB	-
10	L	-
11	G	-
14	B	-
15	GR	-
16	L	-
17	Y	-
18	W	-
19	Y	-
20	SB	-
24	P	-
25	V	-
26	W	-
28	R	-
30	L	-
31	SB	-
32	W	-
33	P	-
34	BR	-
35	R	-
41	LG	-
42	LG	-
43	O	-
44	Y	-
45	P	-
46	P	-
50	V	-
51	O	-

52	GR	- [With automatic drive positioner]
52	R	- [Without automatic drive positioner]
53	L	- [With automatic drive positioner]
53	V	- [Without automatic drive positioner]
54	LG	- [With automatic drive positioner]
54	G	- [Without automatic drive positioner]
55	SB	- [With automatic drive positioner]
55	O	- [Without automatic drive positioner]

Connector No.	M57
Connector Name	CVT SHIFT SELECTOR
Connector Type	TK10FW

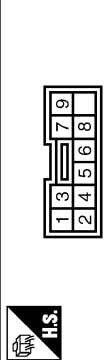

Terminal No.	Color of Wire	Signal Name [Specification]
1	LG	-
4	B	-
6	P	-
7	B	-
8	Y	-
9	V	-

Connector No.	M75
Connector Name	AUTOMATIC DRIVE POSITIONER CONTROL UNIT
Connector Type	TH24FW-NH

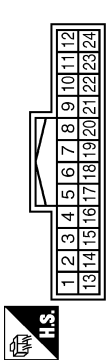

Terminal No.	Color of Wire	Signal Name [Specification]
1	Y	UPWARD
2	GR	SELECT RH
3	SB	UPWARD
4	LG	LEFTWARD
5	R	MIR SENS UP DOWN (RH)
6	Y	MIR SENS UP DOWN (LH)

7	P	FORWARD
8	LG	RX TX
10	O	MIR MTR UP (RH)
11	G	MIR MTR LEFT (RH)
12	R	MIR MTR DOWN RIGHT (LH)
13	LG	DOWNWARD
14	O	SELECT LH
15	L	DOWNWARD
16	V	RIGHTWARD
17	W	MIR SENS LEFT & RIGHT (RH)
18	L	MIR SENS LEFT & RIGHT (LH)
19	G	BACKWARD
20	Y	SENS GND
21	W	SENS POWER
22	V	MIR MTR DOWN RIGHT (RH)
23	L	MIR MTR UP (LH)
24	SB	MIR MTR LEFT (LH)

DRIVER SEAT CONTROL UNIT

< ECU DIAGNOSIS INFORMATION >

AUTOMATIC DRIVE POSITIONER

Connector No.	M77
Connector Name	WIRE TO WIRE
Connector Type	TH80FW-CS1.9

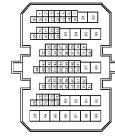

Terminal No.	Color of Wire	Signal Name [Specification]
1	SHIELD	-
2	B	-
3	W	-
4	R	-
5	Y	-
6	W	-
7	G	-
8	SHIELD	-
9	W	-
10	R	-
11	G	-
12	B	-
13	O	-
14	R	-
15	SB	-
16	R	-
17	V	-
18	P	-
19	P	-
20	LG	-
21	Y	-
22	O	-
23	LG	-
24	SB	-
25	Y	-
27	Y	-
28	R	-
30	Y	-
31	W	-
32	BR	-
34	Y	-
35	SHIELD	-
36	G	-
37	Y	-
40	O	-
41	LG	-
42	SB	-
46	LG	-

47	SR	-
48	SHIELD	-
49	R	-
50	LG	-
51	V	-
52	B	-
53	BR	-
54	B	-
55	G	-
56	P	-
57	L	-
58	SB	-
59	SHIELD	-
60	B	-
61	R	-
62	W	-
63	O	-
64	Y	-
65	Y	-
66	V	-
67	GR	-
68	G	-
69	SHIELD	-
70	L	-
71	R	-
72	LG	-
73	Y	-
74	R	-
75	P	-
76	L	-
77	BR	-
79	B	-
80	W	-
81	LG	-
82	L	-
83	W	- [With automatic drive positioner]
83	GR	- [Without automatic drive positioner]
84	R	-
85	V	-
86	W	-
87	R	-
88	G	-
89	B	-
90	O	-
91	G	-
92	BR	-
93	P	-
94	V	-
95	O	-
96	SB	-
97	L	-
98	LG	-

98	Y	-
----	---	---

Connector No.	M89
Connector Name	KEY SLOT
Connector Type	TH12FW-NH

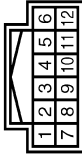

Terminal No.	Color of Wire	Signal Name [Specification]
1	GR	BAT
2	SB	CLOCK
3	O	DATA
5	GR	ILL.BAT
6	R	ILL
7	B	GND
11	Y	KEY SWITCH SIGNAL

Connector No.	M102
Connector Name	TILT & TELESCOPIC SWITCH
Connector Type	TK08FGY



Terminal No.	Color of Wire	Signal Name [Specification]
1	B	-
2	Y	-
3	LG	-
4	G	-
5	P	-

Connector No.	M104
Connector Name	AUTOMATIC DRIVE POSITIONER CONTROL UNIT
Connector Type	NS30FW-CS



Terminal No.	Color of Wire	Signal Name [Specification]
25	W	UPWARD
26	L	BACKWARD
27	P	UPWARD
28	G	DOWNWARD
29	LG	UPWARD / FRONTWARD
30	B	GND

Connector No.	M115
Connector Name	CIRCUIT BREAKER
Connector Type	MM2FV-P-LC



Terminal No.	Color of Wire	Signal Name [Specification]
1	W	-
2	W	-

A
B
C
D
E
F
G
H
I
K
L
M
N
O
P

ADP

DRIVER SEAT CONTROL UNIT

< ECU DIAGNOSIS INFORMATION >

AUTOMATIC DRIVE POSITIONER

Connector No.	M116
Connector Name	TILT MOTOR
Connector Type	NS06FW-CS

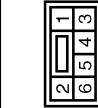

Terminal No.	Color of Wire	Signal Name [Specification]
1	G	-
2	LG	-
4	P	-
5	V	-
6	Y	-

Connector No.	M117
Connector Name	TELESCOPIC MOTOR
Connector Type	NS06FW-CS

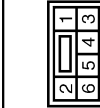

Terminal No.	Color of Wire	Signal Name [Specification]
1	L	-
2	LG	-
4	P	-
5	R	-
6	Y	-

Connector No.	M118
Connector Name	BCM (BODY CONTROL MODULE)
Connector Type	M03FB-LC

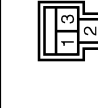

Terminal No.	Color of Wire	Signal Name [Specification]
1	W	BAT (F/L)
2	GR	POWER WINDOW POWER SUPPLY (BAT)
3	L	POWER WINDOW POWER SUPPLY (RAP)

Connector No.	M119
Connector Name	BCM (BODY CONTROL MODULE)
Connector Type	NS16FW-CS

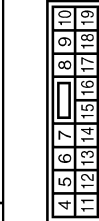

Terminal No.	Color of Wire	Signal Name [Specification]
4	P	INTERIOR ROOM LAMP POWER SUPPLY
5	G	PASSENGER DOOR UNLOCK OUTPUT
7	Y	STEP LAMP OUTPUT
8	V	ALL DOOR FUEL LID LOCK OUTPUT
9	G	DRIVER DOOR FUEL LID UNLOCK OUTPUT
10	P	REAR DOOR UNLOCK OUTPUT
11	LG	BAT (FUSE)
13	B	GND
14	O	PUSH-BUTTON IGNITION SW ILL GND
15	L	ACC IND
17	G	TURN SIGNAL RH
18	BR	TURN SIGNAL LH
19	Y	ROOM LAMP TIMER CONTROL

Connector No.	M122
Connector Name	BCM (BODY CONTROL MODULE)
Connector Type	TH40FB-NH

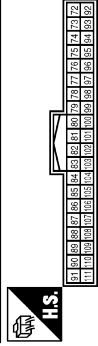

DRIVER SEAT CONTROL UNIT

< ECU DIAGNOSIS INFORMATION >

A
B
C
D
E
F
G
H
I
K
L
M
N
O
P

AUTOMATIC DRIVE POSITIONER

Connector No.	M125
Connector Name	MULTIFUNCTION SWITCH
Connector Type	TH16FV-NH

2	4	6	8	10	12	14	16
1	3	5	7	9	11	13	15



Terminal No.	Color of Wire	Signal Name [Specification]
1	B	GND
3	W	ACC
4	R	ILL
5	B	ILL CONT
6	SB	AV COMM (H)
8	LG	AV COMM (L)
9	V	SW GND
14	W	EJECT SIGNAL

Connector No.	M172
Connector Name	AV CONTROL UNIT
Connector Type	TH24FV-NH

36	37	38	39	40	41	42	43	44	45	46	47
48	49	50	51	52	53	54	55	56	57	58	59



Terminal No.	Color of Wire	Signal Name [Specification]
36	O	SIGNAL VCC
37	SB	SIGNAL GND
38	G	HP
39	L	COMM (DISP->CONT)
40	W	RGB AREA (VS) SIGNAL
41	SHIELD	SHIELD
42	B	RGB SYNC
43	G	RGB (R-RED) SIGNAL
44	L	RGB (G-GREEN) SIGNAL
45	Y	RGB (B-BLUE) SIGNAL
46	V	COMPOSITE IMAGE SIGNAL GND
47	LG	COMPOSITE IMAGE SIGNAL
48	Y	INVERTER VCC
48	BR	INVERTER GND

50	R	VP
51	P	COMM (CONT->DISP)
52	SHIELD	SHIELD
57	SHIELD	SHIELD
58	SHIELD	SHIELD

Connector No.	M174
Connector Name	AV CONTROL UNIT
Connector Type	TH32FV-NH

76	77	78	79	80	81	82	83	84	85	86	87	88	89	90	91
92	93	94	95	96	97	98	99	100	101	102	103	104	105	106	107



Terminal No.	Color of Wire	Signal Name [Specification]
76	LG	AV COMM (L)
77	SB	AV COMM (H)
78	LG	AV COMM (L)
79	SB	AV COMM (H)
80	P	CAN-L
81	L	CAN-H
82	V	SW GND
86	SHIELD	SHIELD
87	R	TEL VOICE SIGNAL (+)
88	L	TEL VOICE SIGNAL (-)
92	V	VEHICLE SPEED SIGNAL (θ-PULSE)
93	LG	PARKING BRAKE (With BOSE system)
93	G	PARKING BRAKE (Without BOSE system)
94	SB	REVERSE
95	G	IGNITION
96	W	DISK EJECT SIGNAL
102	W	AUX SOUND SIGNAL GND
103	B	AUX SOUND SIGNAL LH (+)
104	R	AUX SOUND SIGNAL RH (+)

Connector No.	M180
Connector Name	AV CONTROL UNIT
Connector Type	TH32FV-NH

61	62	63	64	65	66	67	68	69	70	71	72	73	74	75	76
77	78	79	80	81	82	83	84	85	86	87	88	89	90	91	92



Terminal No.	Color of Wire	Signal Name [Specification]
65	LG	PARKING BRAKE
67	BR	COMPOSITE IMAGE SIGNAL GND
68	GR	COMPOSITE IMAGE SIGNAL
71	SHIELD	SHIELD
72	B	MICROPHONE VCC
73	R	COMM (CONT->DISP)
74	P	CAN-L
75	LG	AV COMM (L)
78	LG	AV COMM (L)
79	R	ILLUMINATION SIGNAL
80	G	IGNITION
81	SB	REVERSE
82	V	VEHICLE SPEED SIGNAL (θ-PULSE)
83	SHIELD	SHIELD
87	W	MICROPHONE SIGNAL
88	SHIELD	SHIELD
89	G	COMM (DISP->CONT)
90	L	CAN-H
91	SB	AV COMM (H)
92	SB	AV COMM (H)

Fail Safe

The fail-safe mode may be activated if the following symptoms are observed.

JCJWM1724GB

INFOID:000000006258123

DRIVER SEAT CONTROL UNIT

< ECU DIAGNOSIS INFORMATION >

Operating in fail-safe mode	Malfunction Item	Related DTC	Diagnosis
Only manual functions operate normally.	CAN communication	U1000	ADP-44
	CONTROL UNIT	U1010	ADP-45
	EEPROM	B2130	ADP-46
Only manual functions, except door mirror, operate normally.	UART communication	B2128	ADP-53
Only manual functions, except seat sliding, operate normally.	Seat sliding output	B2112	ADP-47
Only manual functions, except seat reclining, operate normally.	Seat reclining output	B2113	ADP-49
Only manual functions, except steering tilt, operate normally.	Steering column tilt output	B2116	ADP-51

DTC Index

INFOID:000000006258124

CONSULT-III display	Timing ^{*1}		Item	Reference page
	Current malfunction	Previous malfunction		
CAN COMM CIRCUIT [U1000]	0	1-39	CAN communication	ADP-44
CONTROL UNIT [U1010]	0	1-39	Control unit	ADP-45
SEAT SLIDE [B2112]	0	1-39	Seat slide motor output	ADP-47
SEAT RECLINING [B2113]	0	1-39	Seat reclining motor output	ADP-49
STEERING TILT [B2116]	0	1-39	Tilt motor output	ADP-51
UART COMM [B2128]	0	1-39	UART communication	ADP-53
EEPROM [B2130]	0	1-39	EEPROM	ADP-46

*1:

- 0: Current malfunction is present
- 1-39: Displayed if any previous malfunction is present when current condition is normal. The numeral value increases by one at each IGN ON to OFF cycle from 1 to 39. The counter remains at 39 even if the number of cycles exceeds it. However, the counter is reset to 1 if any malfunction is detected again, the normal operation is resumed and the ignition switch is turned from OFF to ON.

AUTOMATIC DRIVE POSITIONER CONTROL UNIT

< ECU DIAGNOSIS INFORMATION >

AUTOMATIC DRIVE POSITIONER CONTROL UNIT

Reference Value

INFOID:000000006258125

TERMINAL LAYOUT

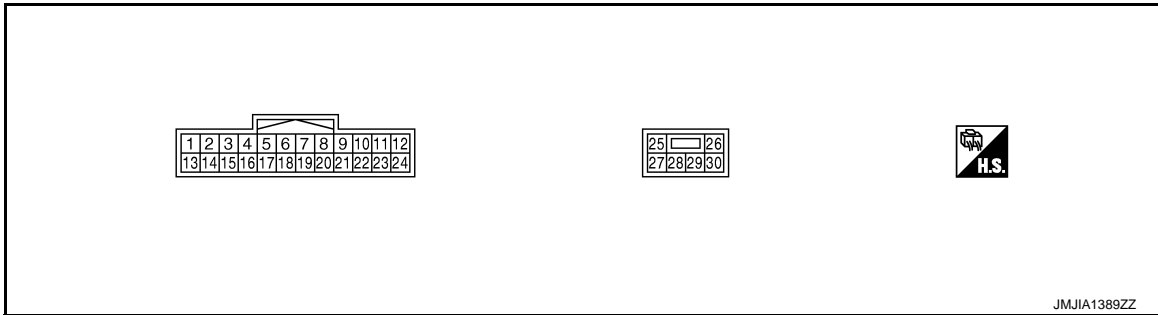

PHYSICAL VALUES

Terminal No. (wire color)		Description		Condition		Voltage (V) (Approx.)
+	-	Signal name	Input/ Output			
1 (Y)	Ground	Tilt switch up signal	Input	Tilt switch	Operate (up)	0
					Other than above	5
2 (GR)	Ground	Changeover switch RH signal	Input	Changeover switch position	RH	0
					Neutral or LH	5
3 (SB)	Ground	Mirror switch up signal	Input	Mirror switch	Operated (up)	0
					Other than above	5
4 (LG)	Ground	Mirror switch left signal	Input	Mirror switch	Operated (left)	0
					Other than above	5
5 (R)	Ground	Door mirror sensor (passenger side) up/down signal	Input	Door mirror RH position		Change between 3.4 (close to peak) 0.6 (close to valley)
6 (Y)	Ground	Door mirror sensor (driver side) up/down signal	Input	Door mirror LH position		Change between 3.4 (close to peak) 0.6 (close to valley)
7 (P)	Ground	Telescopic switch forward signal	Input	Telescopic switch	Operate (forward)	0
					Other than above	5
8 (LG)	Ground	UART communication (TX/RX)	Output	Ignition switch ON		<p style="text-align: right;">JMJA1391ZZ</p>

A
B
C
D
E
F
G
H
I
K
L
M
N
O
P

ADP

AUTOMATIC DRIVE POSITIONER CONTROL UNIT

< ECU DIAGNOSIS INFORMATION >

Terminal No. (wire color)		Description		Condition	Voltage (V) (Approx.)	
+	-	Signal name	Input/ Output			
10 (O)	Ground	Door mirror motor (passenger side) up output signal	Output	Door mirror RH	Operate (up)	Battery voltage
					Other than above	0
11 (G)	Ground	Door mirror motor (passenger side) left output signal	Output	Door mirror RH	Operate (left)	Battery voltage
					Other than above	0
12 (R)	Ground	Door mirror motor (driver side) down output signal	Output	Door mirror (LH)	Operate (down)	Battery voltage
					Other than above	0
		Door mirror motor (driver side) right output signal			Operate (right)	Battery voltage
					Other than above	0
13 (LG)	Ground	Tilt switch down signal	Input	Tilt switch	Operate (down)	0
					Other than above	5
14 (O)	Ground	Changeover switch LH signal	Input	Changeover switch position	LH	0
					Neutral or RH	5
15 (L)	Ground	Mirror switch down signal	Input	Mirror switch	Operate (down)	0
					Other than above	5
16 (V)	Ground	Mirror switch right signal	Input	Mirror switch	Operate (right)	0
					Other than above	5
17 (W)	Ground	Door mirror sensor (passenger side) left/right signal	Input	Door mirror RH position	Change between 3.4 (close to left edge) 0.6 (close to right edge)	
18 (L)	Ground	Door mirror sensor (driver side) left/right signal	Input	Door mirror LH position	Change between 0.6 (close to left edge) 3.4 (close to right edge)	
19 (G)	Ground	Telescopic switch backward signal	Input	Telescopic switch	Operate (backward)	0
					Other than above	5
20 (Y)	Ground	Ground	—	—	0	
21 (W)	Ground	Door mirror motor sensor power supply	Input	—	5	

AUTOMATIC DRIVE POSITIONER CONTROL UNIT

< ECU DIAGNOSIS INFORMATION >

Terminal No. (wire color)		Description		Condition	Voltage (V) (Approx.)	
+	-	Signal name	Input/ Output			
22 (V)	Ground	Door mirror motor (passenger side) down output signal	Output	Door mirror (RH)	Operate (down)	Battery voltage
					Other than above	0
		Door mirror motor (passenger side) right output signal			Operate (right)	Battery voltage
					Other than above	0
23 (L)	Ground	Door mirror motor (driver side)up output signal	Output	Door mirror (LH)	Operate (up)	Battery voltage
					Other than above	0
24 (SB)	Ground	Door mirror motor (driver side)left output signal	Output	Door mirror (LH)	Operate (left)	Battery voltage
					Other than above	0
25 (W)	Ground	Power source	Input	—	Battery voltage	
26 (L)	Ground	Telescopic motor backward output signal	Output	Steering telescopic	Operate (backward)	Battery voltage
					Other than above	0
27 (P)	Ground	Tilt&telescopic motor power source		—	Battery voltage	
28 (G)	Ground	Tilt motor down output signal	Output	Steering tilt	Operate (down)	Battery voltage
					Other than above	0
29 (LG)	Ground	Tilt motor up output signal	Output	Steering tilt	Operate (up)	Battery voltage
					Other than above	0
		Telescopic motor forward output signal		Steering telescopic	Operate (forward)	Battery voltage
					Other than above	0
30 (B)	Ground	Ground	—	—	0	

A
B
C
D
E
F
G
H
I
ADP
K
L
M
N
O
P

AUTOMATIC DRIVE POSITIONER CONTROL UNIT

< ECU DIAGNOSIS INFORMATION >

Wiring Diagram - AUTOMATIC DRIVE POSITIONER CONTROL SYSTEM -

INFOID:000000006882468

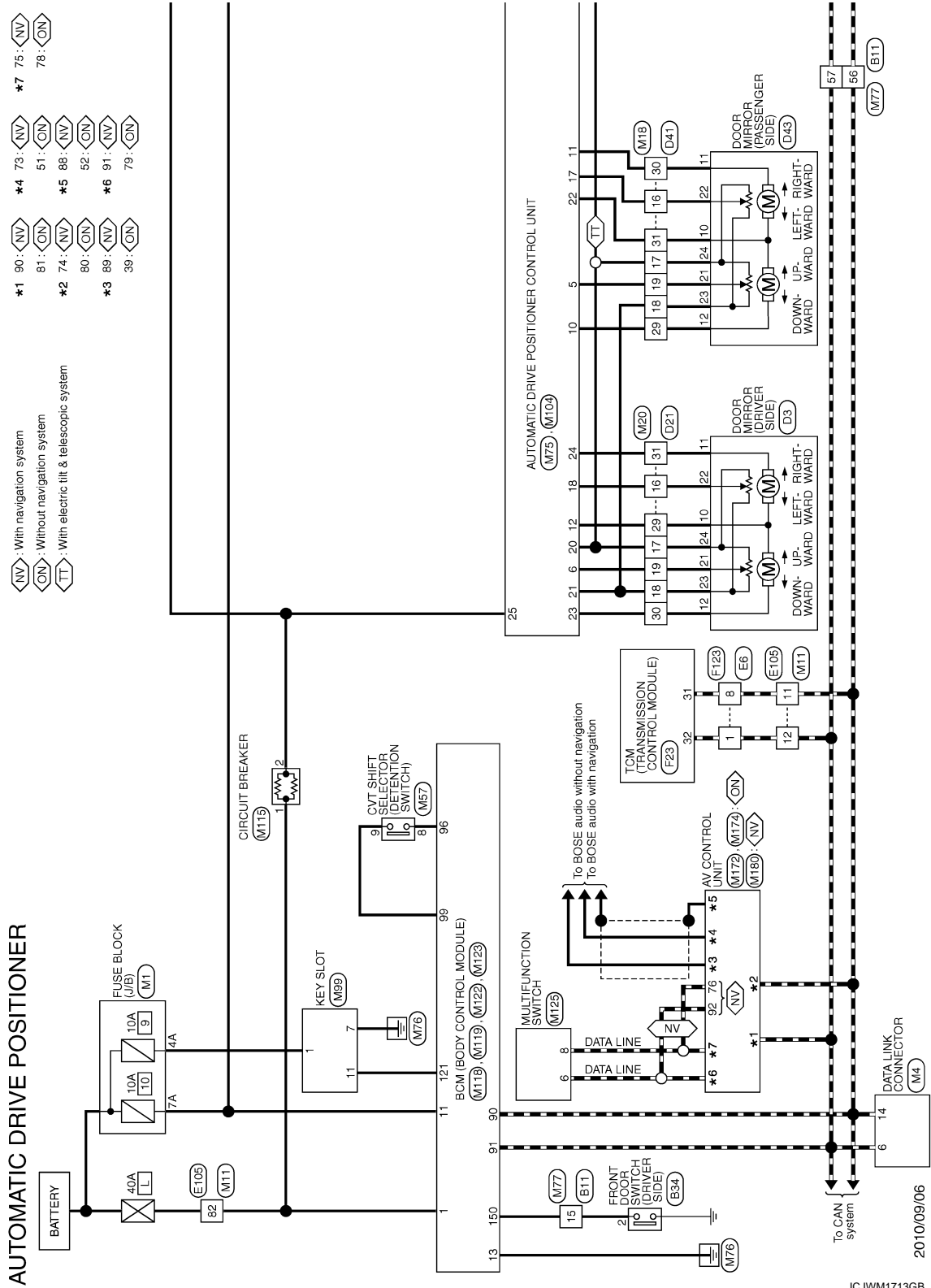

2010/09/06

JCJWM1713GB

AUTOMATIC DRIVE POSITIONER CONTROL UNIT

< ECU DIAGNOSIS INFORMATION >

Ⓣ : With electric tilt & telescopic system

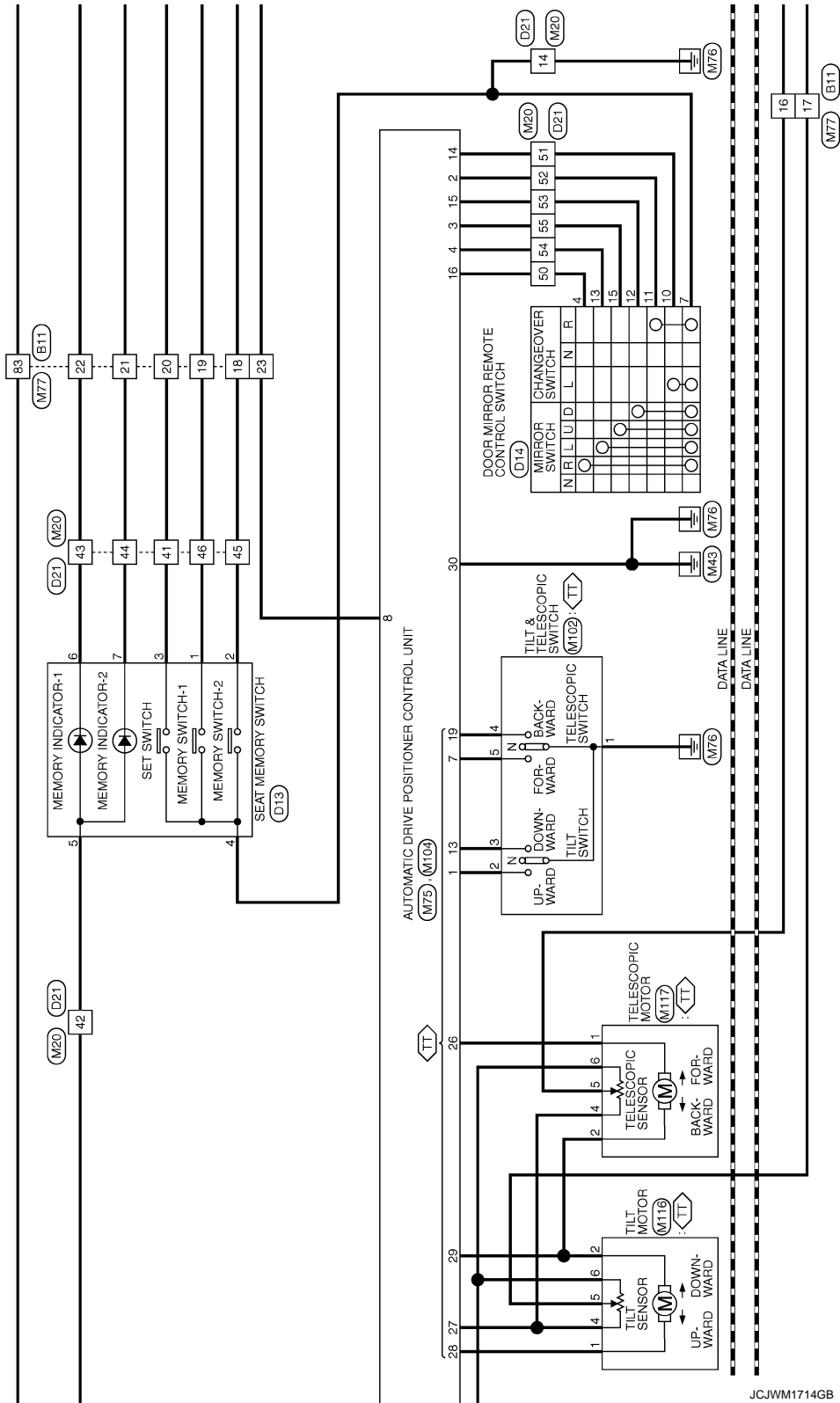

A
B
C
D
E
F
G
H
I
J
K
L
M
N
O
P

ADP

AUTOMATIC DRIVE POSITIONER CONTROL UNIT

< ECU DIAGNOSIS INFORMATION >

 : With electric tilt & telescopic system

* : This connector is not shown in "Harness Layout".

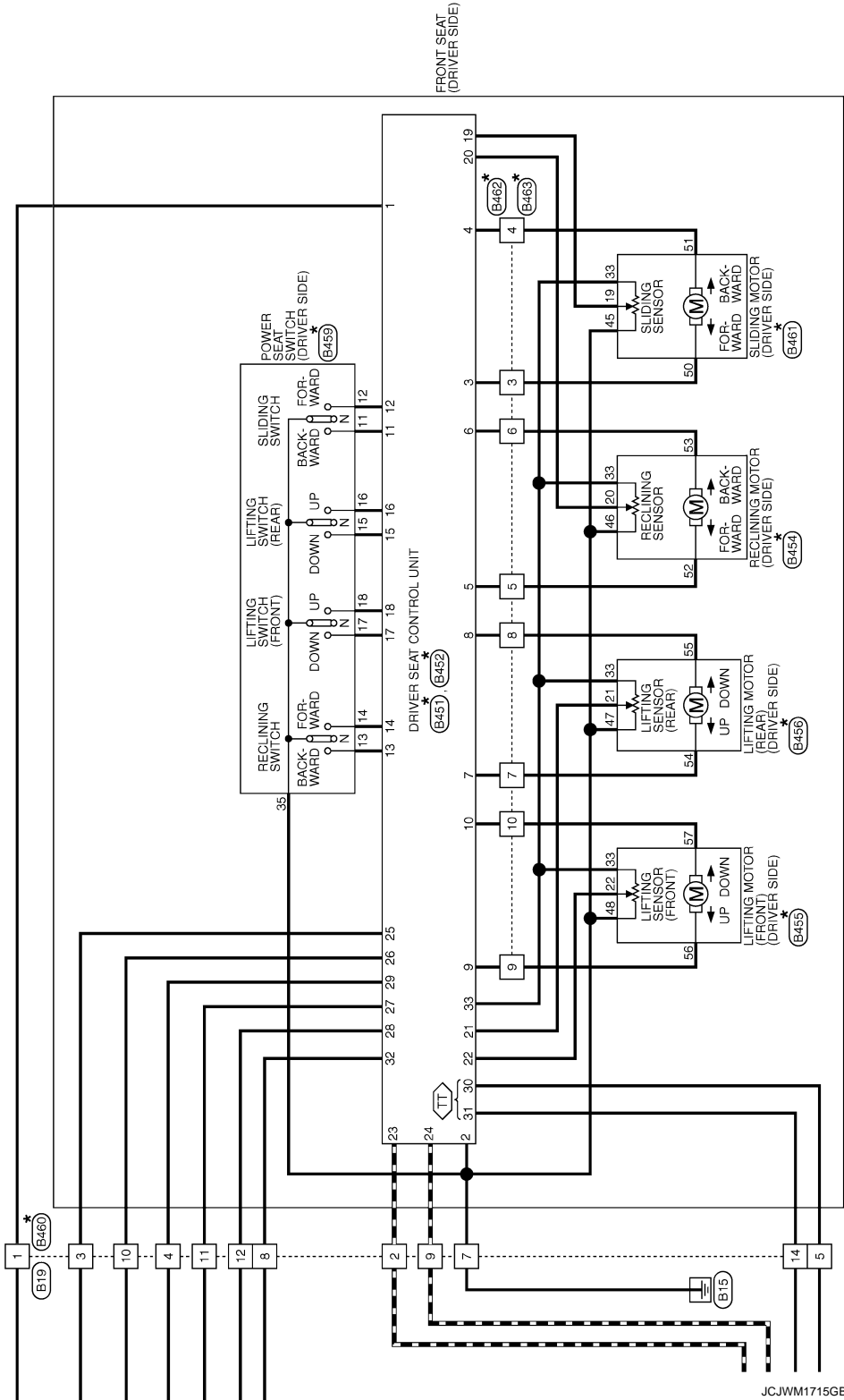

JCJWM1715GB

AUTOMATIC DRIVE POSITIONER CONTROL UNIT

< ECU DIAGNOSIS INFORMATION >

AUTOMATIC DRIVE POSITIONER

Connector No.	B11
Connector Name	WIRE TO WIRE
Connector Type	TH80MW-CS:9

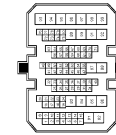

Terminal No.	Color of Wire	Signal Name [Specification]
1	SHIELD	-
2	B	-
3	R/L	-
4	R/W	-
5	SB	-
6	P	-
7	V	-
8	SHIELD	-
9	BR/L	-
10	Y/G	-
11	Y/L	-
12	W/L	-
13	L	-
14	BR	-
15	SB	-
16	BR	-
17	V	-
18	SB	-
19	R	-
20	P	-
21	LG	-
22	W	-
23	Y	-
24	GR	-
25	Y	-
27	V	-
28	W/L	-
30	P	-
31	O	-
32	BR	-
34	SB	-
35	SHIELD	-
36	L/O	-
37	LG	-
40	Y	-
41	GR	-
42	SB	-
46	LG	-

47	SB	-
48	SHIELD	-
49	B	-
50	R/W	-
51	R/L	-
52	B	-
53	Y	-
54	LG	-
55	BR	-
56	P	-
57	L	-
58	R	-
59	SHIELD	-
60	B	-
61	R/L	-
62	R/W	-
63	LG	-
64	Y	-
65	BR	-
66	V	-
67	GR	-
68	R	-
69	SHIELD	-
70	W/R	-
71	B/R	-
72	Y	-
73	LG	-
74	SB	-
75	L	-
76	G	-
77	R	-
79	B	-
80	W	-
81	R	-
82	L	-
83	BR	-
84	O	-
85	G	-
86	SB	-
87	R	-
88	G	-
89	GR	-
90	Y	-
91	G	-
92	BR	-
93	G	-
94	V	-
95	BR	-
96	GR	-
97	R	-
98	LG	-
99	O	-

Connector No.	B19
Connector Name	WIRE TO WIRE
Connector Type	MS16FW-CS

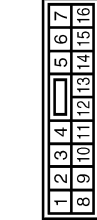

Terminal No.	Color of Wire	Signal Name [Specification]
1	BR	-
2	L	-
3	W	-
4	P	-
5	V	-
6	GR	-
7	B	-
8	Y	-
9	P	-
10	LG	-
11	R	-
12	SB	-
13	O	-
14	BR	-
15	G	-
16	B/W	-

Connector No.	B34
Connector Name	FRONT DOOR SWITCH (DRIVER SIDE)
Connector Type	A03FW

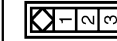

Terminal No.	Color of Wire	Signal Name [Specification]
2	SB	-

Connector No.	B451
Connector Name	DRIVER SEAT CONTROL UNIT
Connector Type	MS12FW-CS

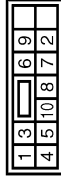

Terminal No.	Color of Wire	Signal Name [Specification]
1	R	-
2	B	-
3	G	-
4	G/R	-
5	V	-
6	R/L	-
7	L	-
8	L/W	-
9	L/R	-
10	L/B	-

A
B
C
D
E
F
G
H
I
K
L
M
N
O
P

ADP

JCJWM1716GB

AUTOMATIC DRIVE POSITIONER CONTROL UNIT

< ECU DIAGNOSIS INFORMATION >

AUTOMATIC DRIVE POSITIONER

Connector No.	B452
Connector Name	DRIVER SEAT CONTROL UNIT
Connector Type	TH227W

Terminal No.	23	24	19	22	21	30	27	25	12	14	18	16	28	11	13	17	15	33	
Color of Wire	G/B	G/B	G/W	R/G	R/W	Y/B	Y/R	L/C/B	L/C/R	G/Y	R/Y	L/Y	P	P	P/L	G/O	L/O	V	V/W
Signal Name [Specification]																			

Terminal No.	11	12	13	14	15	16	17	18	19	20	21	22	23	24	25	26	27	28	29	30	31	32	33
Color of Wire	G/B	G/W	R/G	R/W	Y/B	Y/R	L/C/B	L/C/R	G/Y	R/Y	L/Y	BR/Y	P	P/L	G/O	L/O	V	V/W	O/L	BR	BR/W	W/L	W
Signal Name [Specification]																							

Connector No.	B454
Connector Name	RECLINING MOTOR (DRIVER SIDE)
Connector Type	F 8098-0344

Terminal No.	53	52	33	46	20
Color of Wire					
Signal Name [Specification]					

Terminal No.	20	32	46	32	53
Color of Wire	R/Y	W	B/W	V	R/L
Signal Name [Specification]					

Connector No.	B455
Connector Name	LIFTING MOTOR (FRONT) (DRIVER SIDE)
Connector Type	F 6098-0344

Terminal No.	57	56	33	48	22
Color of Wire					
Signal Name [Specification]					

Terminal No.	22	33	48	56	57
Color of Wire	BR/Y	W	P/B	L/R	L/B
Signal Name [Specification]					

Connector No.	B456
Connector Name	LIFTING MOTOR (REAR) (DRIVER SIDE)
Connector Type	F 6098-0344

Terminal No.	55	54	33	47	21
Color of Wire					
Signal Name [Specification]					

Connector No.	B459
Connector Name	POWER SEAT SWITCH (DRIVER SIDE)
Connector Type	NS10FW-CS

Terminal No.	35	13	14	11	12	17	18
Color of Wire							
Signal Name [Specification]							

Terminal No.	11	12	13	14	15	16	17	18	35
Color of Wire	G/B	G/W	R/G	R/W	Y/B	Y/R	L/C/B	L/C/R	B
Signal Name [Specification]									

Connector No.	B460
Connector Name	WIRE TO WIRE
Connector Type	NS18MW-CS

Terminal No.	7	6	5	16	15	14	13	12	11	10	9	8
Color of Wire												
Signal Name [Specification]												

Terminal No.	1	2	3	4	5	6	7	8	9	10	11	12	13
Color of Wire	R	P	G/O	O/L	BR	W/G	B	W/L	P/L	L/O	V	V/W	W/R
Signal Name [Specification]													

Terminal No.	14	15	16
Color of Wire	BR/W	B/R	GR
Signal Name [Specification]			

Connector No.	B461
Connector Name	SLIDING MOTOR (DRIVER SIDE)
Connector Type	F 6098-0344

Terminal No.	51	33	45	19	60
Color of Wire					
Signal Name [Specification]					

Terminal No.	19	33	45	51
Color of Wire	G/Y	W	W/B	G/R
Signal Name [Specification]				

Connector No.	B462
Connector Name	WIRE TO WIRE
Connector Type	NS10MW-CS

Terminal No.	8	7	38	69	10	9	4	13	16	15
Color of Wire										
Signal Name [Specification]										

Terminal No.	3	4	5	6	7	8	9	10	38	39
Color of Wire	G	G/R	V	R/L	L	L/W	L/R	L/B	Y/W	Y
Signal Name [Specification]										

AUTOMATIC DRIVE POSITIONER CONTROL UNIT

< ECU DIAGNOSIS INFORMATION >

AUTOMATIC DRIVE POSITIONER

Connector No.	B463
Connector Name	WIRE TO WIRE
Connector Type	MS10PW-CS

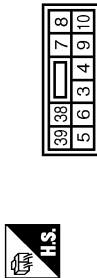

Terminal No.	Color of Wire	Signal Name [Specification]
3	G	-
4	G/R	-
5	V	-
6	R/L	-
7	L/W	-
8	L/R	-
10	L/B	-
38	Y/W	-
39	Y	-

Connector No.	D3
Connector Name	DOOR MIRROR (DRIVER SIDE)
Connector Type	TH24MW-NH

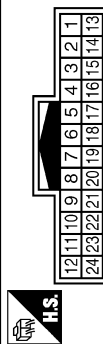

Terminal No.	Color of Wire	Signal Name [Specification]
7	LG	-
10	V	-
11	BR	-
12	SB	-
19	B	-
21	BR	-
22	G	-
23	GR	-
24	Y	-

Connector No.	D13
Connector Name	SEAT MEMORY SWITCH
Connector Type	A08FW



Terminal No.	Color of Wire	Signal Name [Specification]
1	R	-
2	G	-
3	P	-
4	B	-
5	GR	-
6	L	-
7	W	-

Connector No.	D14
Connector Name	DOOR MIRROR REMOTE CONTROL SWITCH
Connector Type	TK18FBR

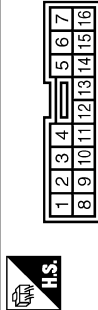

Terminal No.	Color of Wire	Signal Name [Specification]
4	V	-
7	B	-
8	Y	-
9	L	-
10	O	-
11	P	-
12	L	-
13	SB	-
15	LG	-

Connector No.	B21
Connector Name	WIRE TO WIRE
Connector Type	TH40FW-CS15

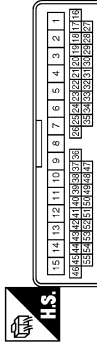

Terminal No.	Color of Wire	Signal Name [Specification]
1	V	-
2	G	-
3	P	-
4	B	-
5	W	-
6	SB	-
7	P	-
8	BR	-
9	GR	-
10	V	-
11	O	-
14	B	-
15	LG	-
16	G	-
17	Y	-
18	GR	-
19	BR	-
20	LG	-
24	P	-
25	V	-
26	W	-
28	V	-
30	SB	-
31	BR	-
32	R	-
33	G	-
34	Y	-
35	L	-
41	P	-
42	GR	-
43	L	-
44	W	-
45	SB	-
46	R	-
50	V	-
51	O	-
52	P	-
53	L	-

53	L	- [With automatic drive positioner]
53	P	- [Without automatic drive positioner]
54	SB	- [With automatic drive positioner]
54	LG	- [Without automatic drive positioner]
55	LG	- [With automatic drive positioner]
55	O	- [Without automatic drive positioner]

Connector No.	D41
Connector Name	WIRE TO WIRE
Connector Type	TH40FW-CS15

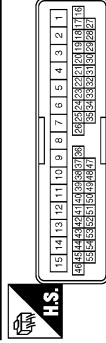

Terminal No.	Color of Wire	Signal Name [Specification]
1	G	-
2	V	-
4	B	-
5	W	-
6	P	-
7	O	-
8	B	-
16	G	-
17	Y	-
18	GR	-
19	BR	-
20	LG	-
24	LG	-
25	W	-
26	O	-
29	V	-
30	SB	-
31	BR	-
32	R	-
33	G	-
34	Y	-
35	L	-

A
B
C
D
E
F
G
H
I
K
L
M
N
O
P

ADP

AUTOMATIC DRIVE POSITIONER CONTROL UNIT

< ECU DIAGNOSIS INFORMATION >

AUTOMATIC DRIVE POSITIONER

Connector No.	D43
Connector Name	DOOR MIRROR (PASSENGER SIDE)
Connector Type	TH2AMV-NH

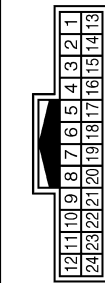

Terminal No.	Color of Wire	Signal Name [Specification]
7	LG	-
10	BR	-
11	SB	-
12	V	-
18	B	-
21	BR	-
22	G	-
23	GR	-
24	Y	-

Connector No.	E5
Connector Name	WIRE TO WIRE
Connector Type	TK6MGY-IV



Terminal No.	Color of Wire	Signal Name [Specification]
1	L	-
3	Y	-
4	R	-
5	GR	-
6	V	-
8	P	-
10	W	-
11	G	-
12	BR	-
13	SB	-
14	B	-

Connector No.	E105
Connector Name	WIRE TO WIRE
Connector Type	TH7DMV-SS0-M3

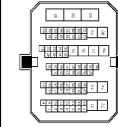

Terminal No.	Color of Wire	Signal Name [Specification]
3	Y	-
5	LG	-
6	GR	-
8	G	-
11	P	-
12	L	-
13	Y	-
14	O	-
15	BR	-
20	Y	-
21	BR	-
22	P	-
24	L	-
25	O	-
28	SB	-
29	W	-
30	Y	-
47	P	-
48	L	-
49	SB	-
50	GR	-
51	LG	-
52	V	-
53	GR	-
54	BR	-
55	Y	-
56	W/L	-
60	V	-
61	BR	-
62	O	-
63	L/O	-
64	SHIELD	-
66	W	-
67	BR	-
68	Y	-
69	SB	-
70	GR	-
71	SB	-

72	Y	-
73	L	-
74	W	-
75	BR	-
76	GR	-
77	O	-
78	Y	- [With navigation system]
78	G	- [With iPod without navigation system]
78	V	- [Without iPod and navigation system]
79	Y	-
80	R	-
81	W	-
82	LG	-
83	O	-

Connector No.	F23
Connector Name	TCM (TRANSMISSION CONTROL MODULE)
Connector Type	RM40FB-R2B-L-RH



Terminal No.	Color of Wire	Signal Name [Specification]
1	P/B	INH SW 2
2	P/L	INH SW 3
3	G/O	INH SW 4
4	GR	INH SW 3 MON
5	B	GND
7	W	SENSOR GND
8	G/W	CLOCK (SEL 2)
9	L/R	CHP SELECT (SEL 1)
10	BR/R	DATA I/O (SEL 3)
11	BR/W	INH SW 1
13	V	ATF TEMP SENSOR
14	R/W	PRI PRESS SENSOR
15	V/W	SEC PRESS SENSOR
19	G/B	REV LAMP RELAY
20	R/B	STARTER RELAY
25	W/R	SENSOR GND
26	L/O	SENSOR POWER SOURCE (5V)
27	R/G	S/M-D
28	R	S/M-C
29	O/B	S/M-B
30	G/R	S/M-A
31	P	CAN-L

32	L	CAN-H
33	LG	PRI SPEED SENSOR
34	LG/R	SEC SPEED SENSOR
37	V/R	L/U 8 SEL-ON/OFF SOL
38	L/W	L/U 8 SEL LINEAR SOL
39	W/B	SEC LINEAR SOL
40	R/Y	PL LINEAR SOL
42	B	GND
46	Y	VIGN
47	L/R	BATT
48	Y	VIGN

Connector No.	F123
Connector Name	WIRE TO WIRE
Connector Type	TK16FGY-IV



Terminal No.	Color of Wire	Signal Name [Specification]
1	L	-
3	G/R	-
4	G/B	-
5	R	-
6	L/R	-
8	P	-
10	Y/B	-
11	BR/W	-
12	BR	-
13	G	-
14	B	-

AUTOMATIC DRIVE POSITIONER CONTROL UNIT

< ECU DIAGNOSIS INFORMATION >

AUTOMATIC DRIVE POSITIONER

Connector No.	M1
Connector Name	FUSE BLOCK (J/B)
Connector Type	NS86FW-M2



Terminal No.	Color of Wire	Signal Name [Specification]
1A	Y	-
2A	G	-
3A	Y	-
4A	GR	-
5A	R	-
6A	W	-
7A	LG	-
8A	Y	-

Connector No.	M4
Connector Name	DATA LINK CONNECTOR
Connector Type	BD16FW

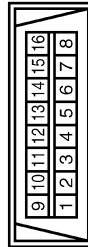

Terminal No.	Color of Wire	Signal Name [Specification]
3	LG	-
4	B	-
5	B	-
6	L	-
7	O	-
8	G	-
11	SB	-
14	P	-
16	Y	-

Connector No.	M11
Connector Name	WIRE TO WIRE
Connector Type	TH7DFW-CS10-M3



Terminal No.	Color of Wire	Signal Name [Specification]
3	P	-
5	O	-
6	G	-
8	R	-
11	P	-
12	L	-
13	V	-
14	Y	-
15	R	-
20	Y	-
21	BR	-
22	G	-
24	Y	-
25	L	-
28	BR	-
29	L	-
30	R	-
47	P	-
48	L	-
49	W	-
50	GR	-
51	LG	-
52	LG	-
53	V	-
54	SB	-
55	P	-
56	SB	-
60	V	-
61	GR	-
62	O	-
63	V	-
64	SHIELD	-
66	W	-
67	R	-
68	W	-
69	P	-
70	G	-
71	G	-

72	BR	-
73	L	-
74	W	-
75	BR	-
76	R	-
77	G	-
78	Y	-
79	G	-
80	R	-
81	W	-
82	W	-
83	O	-

Connector No.	M18
Connector Name	WIRE TO WIRE
Connector Type	TH40MW-CS15

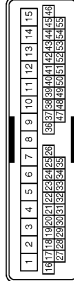

Terminal No.	Color of Wire	Signal Name [Specification]
1	G	-
2	V	-
4	L	- [With iPod without BOSE system]
4	W	- [With BOSE system and base audio without iPod]
5	B	- [With BOSE system]
5	W	- [With iPod without BOSE system]
5	BR	- [Without iPod and BOSE system]
8	GR	-
7	G	-
7	B	-
8	W	-
16	W	-
17	Y	-
18	W	-
19	R	-
20	SB	-
24	LG	-
25	Y	-
26	P	-
29	O	-
30	G	-
31	V	-
32	Y	-
33	P	-
34	BR	-

35	R	-
----	---	---

A
B
C
D
E
F
G
H
I
ADP
K
L
M
N
O
P

AUTOMATIC DRIVE POSITIONER CONTROL UNIT

< ECU DIAGNOSIS INFORMATION >

AUTOMATIC DRIVE POSITIONER

Connector No.	M20
Connector Name	WIRE TO WIRE
Connector Type	TH40MW-CS15

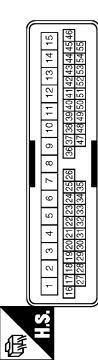

Terminal No.	Color of Wire	Signal Name [Specification]
1	V	-
2	G	-
3	W	-
4	R	- [With iPod without BOSE system]
4	B	- [With BOSE system and base audio without iPod]
5	G	- [With iPod without BOSE system]
5	L	- [With BOSE system and base audio without iPod]
6	V	-
7	BR	-
8	O	-
9	SB	-
10	L	-
11	G	-
14	B	-
15	GR	-
16	L	-
17	Y	-
18	W	-
19	Y	-
20	SB	-
24	P	-
25	V	-
26	W	-
28	R	-
30	L	-
31	SB	-
32	W	-
33	P	-
34	BR	-
35	R	-
41	LG	-
42	LG	-
43	O	-
44	Y	-
45	P	-
46	P	-
50	V	-
51	O	-

52	GR	- [With automatic drive positioner]
52	R	- [Without automatic drive positioner]
53	L	- [With automatic drive positioner]
53	V	- [Without automatic drive positioner]
54	LG	- [With automatic drive positioner]
54	G	- [Without automatic drive positioner]
55	SB	- [With automatic drive positioner]
55	O	- [Without automatic drive positioner]

Connector No.	M57
Connector Name	CVT SHIFT SELECTOR
Connector Type	TK10FW

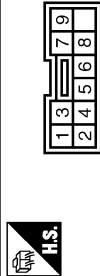

Terminal No.	Color of Wire	Signal Name [Specification]
1	LG	-
4	B	-
6	P	-
7	B	-
8	Y	-
9	V	-

Connector No.	M75
Connector Name	AUTOMATIC DRIVE POSITIONER CONTROL UNIT
Connector Type	TH24FW-NH

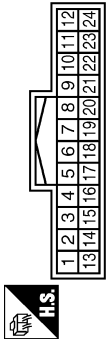

Terminal No.	Color of Wire	Signal Name [Specification]
1	Y	UPWARD
2	GR	SELECT RH
3	SB	UPWARD
4	LG	LEFTWARD
5	R	MIR.SENS.UP.DOWN (RH)
6	Y	MIR.SENS.UP.DOWN (LH)

7	P	FORWARD
8	LG	RX.TX
10	O	MIR.MTR.UP (RH)
11	G	MIR.MTR.LEFT (RH)
12	R	MIR.MTR.DOWN.RIGHT (LH)
13	LG	DOWNWARD
14	O	SELECT LH
15	L	DOWNWARD
16	V	RIGHTWARD
17	W	MIR.SENS.LEFT & RIGHT (RH)
18	L	MIR.SENS.LEFT & RIGHT (LH)
19	G	BACKWARD
20	Y	SENS.GND
21	W	SENS.POWER
22	V	MIR.MTR.DOWN.RIGHT (RH)
23	L	MIR.MTR.UP (LH)
24	SB	MIR.MTR.LEFT (LH)

AUTOMATIC DRIVE POSITIONER CONTROL UNIT

< ECU DIAGNOSIS INFORMATION >

AUTOMATIC DRIVE POSITIONER

Connector No.	M77
Connector Name	WIRE TO WIRE
Connector Type	TH80FW-CS1.9

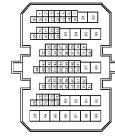

Terminal No.	Color of Wire	Signal Name [Specification]
1	SHIELD	
2	B	
3	W	
4	R	
5	Y	
6	W	
7	G	
8	SHIELD	
9	W	
10	R	
11	G	
12	B	
13	O	
14	R	
15	SB	
16	R	
17	V	
18	P	
19	P	
20	LG	
21	Y	
22	O	
23	LG	
24	SB	
25	Y	
27	Y	
28	R	
30	Y	
31	W	
32	BR	
34	Y	
35	SHIELD	
36	G	
37	Y	
40	O	
41	LG	
42	SB	
46	LG	

47	SR	
48	SHIELD	
49	R	
50	LG	
51	V	
52	B	
53	BR	
54	B	
55	G	
56	P	
57	L	
58	SB	
59	SHIELD	
60	B	
61	R	
62	W	
63	O	
64	Y	
65	Y	
66	V	
67	GR	
68	G	
69	SHIELD	
70	L	
71	R	
72	LG	
73	Y	
74	R	
75	P	
76	L	
77	BR	
79	B	
80	W	
81	LG	
82	L	
83	W	
83	GR	
84	R	
85	V	
86	W	
87	R	
88	G	
89	B	
90	O	
91	G	
92	BR	
93	P	
94	V	
95	O	
96	SB	
97	L	
98	LG	

98	Y	-
----	---	---

Connector No.	M89
Connector Name	KEY SLOT
Connector Type	TH12FW-NH

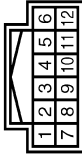

Terminal No.	Color of Wire	Signal Name [Specification]
1	GR	BAT
2	SB	CLOCK
3	O	DATA
5	GR	ILL BAT
6	R	ILL
7	B	GND
11	Y	KEY SWITCH SIGNAL

Connector No.	M102
Connector Name	TILT & TELESCOPIC SWITCH
Connector Type	TK08FGY



Terminal No.	Color of Wire	Signal Name [Specification]
1	B	
2	Y	
3	LG	
4	G	
5	P	

Connector No.	M104
Connector Name	AUTOMATIC DRIVE POSITIONER CONTROL UNIT
Connector Type	NS30FW-CS



Terminal No.	Color of Wire	Signal Name [Specification]
25	W	UPWARD
26	L	BACKWARD
27	P	UPWARD
28	G	DOWNWARD
29	LG	UPWARD / FRONTWARD
30	B	GND

Connector No.	M115
Connector Name	CIRCUIT BREAKER
Connector Type	MM2FV-P-LC



Terminal No.	Color of Wire	Signal Name [Specification]
1	W	
2	W	

A
B
C
D
E
F
G
H
I
K
L
M
N
O
P

ADP

AUTOMATIC DRIVE POSITIONER CONTROL UNIT

< ECU DIAGNOSIS INFORMATION >

AUTOMATIC DRIVE POSITIONER

Connector No.	M116
Connector Name	TILT MOTOR
Connector Type	NS06FW-CS

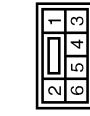

Terminal No.	Color of Wire	Signal Name [Specification]
1	G	-
2	LG	-
4	P	-
5	V	-
6	Y	-

Connector No.	M117
Connector Name	TELESCOPIC MOTOR
Connector Type	NS06FW-CS



Terminal No.	Color of Wire	Signal Name [Specification]
1	L	-
2	LG	-
4	P	-
5	R	-
6	Y	-

Connector No.	M118
Connector Name	BCM (BODY CONTROL MODULE)
Connector Type	M03FB-LC



Terminal No.	Color of Wire	Signal Name [Specification]
1	W	BAT (F/L)
2	GR	POWER WINDOW POWER SUPPLY (BAT)
3	L	POWER WINDOW POWER SUPPLY (RAP)

Connector No.	M119
Connector Name	BCM (BODY CONTROL MODULE)
Connector Type	NS16FW-CS



Terminal No.	Color of Wire	Signal Name [Specification]
4	P	INTERIOR ROOM LAMP POWER SUPPLY
5	G	PASSENGER DOOR UNLOCK OUTPUT
7	Y	STEP LAMP OUTPUT
8	V	ALL DOOR FUEL LID LOCK OUTPUT
9	G	DRIVER DOOR FUEL LID UNLOCK OUTPUT
10	P	REAR DOOR UNLOCK OUTPUT
11	LG	BAT FUSE
13	B	GND
14	O	PUSH-BUTTON IGNITION SW ILL GND
15	L	ACC IND
17	G	TURN SIGNAL RH
18	BR	TURN SIGNAL LH
19	Y	ROOM LAMP TIMER CONTROL

Connector No.	M122
Connector Name	BCM (BODY CONTROL MODULE)
Connector Type	TH40FB-NH

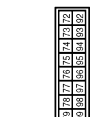

Terminal No.	Color of Wire	Signal Name [Specification]
72	B	ROOM ANT 2-
73	W	ROOM ANT 2+
74	Y	PASSENGER DOOR ANT-
75	LG	PASSENGER DOOR ANT+
76	V	DRIVER DOOR ANT-
77	P	DRIVER DOOR ANT+
80	SB	IMMOBI ANTENNA CONTROL
81	O	IMMOBI ANTENNA SIGNAL
82	BR	IGN RELAY (F/B) CONT
83	P	KEYLESS ENTRY RECEIVER SIGNAL
87	R	COMBI SW INPUT 5
88	GR	CAN-L
90	P	CAN-H
91	L	CAN-L
92	R	KEY SLOT ILL
93	P	ON IND
95	L	ACC RELAY CONT
96	Y	CVT SHIFT SELECTOR POWER SUPPLY
99	V	SHIFT P
100	P	PASSENGER DOOR REQUEST SW
101	W	DRIVER DOOR REQUEST SW
102	Y	BLOWER FAN MOTOR RELAY CONT
103	L	KEYLESS ENTRY RECEIVER POWER SUPPLY
107	O	COMBI SW INPUT 1
108	P	COMBI SW INPUT 4
109	SB	COMBI SW INPUT 2
110	G	HAZARD SW

Connector No.	M123
Connector Name	BCM (BODY CONTROL MODULE)
Connector Type	TH40FG-NH



Terminal No.	Color of Wire	Signal Name [Specification]
112	R	RAIN SENSOR SERIAL LINK
113	O	OPTICAL SENSOR
116	GR	FUSE CHECK
118	L	STOP LAMP SW
119	W	DR DOOR UNLOCK SENSOR
121	Y	KEY SLOT SW
123	G	IGN F/B
124	R	PASSENGER DOOR SW
130	BR	REAR DEFOGGER SW
132	G	POWER WINDOW SW COMM
133	W	PUSH-BUTTON IGNITION SW ILL POWER
134	R	LOCK IND
137	P	RECEIVER / SENSOR GND
138	V	RECEIVER / SENSOR POWER SUPPLY
139	O	TIRE PRESS RECEIVER SIGNAL
140	GR	SHIFT N/P
141	O	SECURITY INDICATOR OUTPUT
142	L	COMBI SW OUTPUT 5
143	W	COMBI SW OUTPUT 1
144	P	COMBI SW OUTPUT 2
145	V	COMBI SW OUTPUT 3
146	Y	COMBI SW OUTPUT 4
150	SB	DRIVER DOOR SW
151	G	REAR WINDOW DEFOGGER RELAY

JCJWM1723GB

AUTOMATIC DRIVE POSITIONER CONTROL UNIT

< ECU DIAGNOSIS INFORMATION >

AUTOMATIC DRIVE POSITIONER

Connector No.	M125
Connector Name	MULTIFUNCTION SWITCH
Connector Type	TH16FW-NH



2	4	6	8	10	12	14	16
1	3	5	7	9	11	13	15

Terminal No.	Color of Wire	Signal Name [Specification]
1	B	GND
3	W	ACC
4	R	ILL
5	B	ILL CONT
6	SB	AV COMM (H)
8	LG	AV COMM (L)
9	V	SW GND
14	W	EJECT SIGNAL

Connector No.	M172
Connector Name	AV CONTROL UNIT
Connector Type	TH24FW-NH



36	37	38	39	40	41	42	43	44	45	46	47
48	49	50	51	52	53	54	55	56	57	58	59

Terminal No.	Color of Wire	Signal Name [Specification]
36	O	SIGNAL VCC
37	SB	SIGNAL GND
38	G	HP
39	L	COMM (DISP->CONT)
40	W	RGB AREA (VS) SIGNAL
41	SHIELD	SHIELD
42	B	RGB SYNC
43	G	RGB (R-RED) SIGNAL
44	L	RGB (G-GREEN) SIGNAL
45	Y	RGB (B-BLUE) SIGNAL
46	V	COMPOSITE IMAGE SIGNAL GND
47	LG	COMPOSITE IMAGE SIGNAL
48	Y	INVERTER VCC
48	BR	INVERTER GND

50	R	VP
51	P	COMM (CONT->DISP)
52	SHIELD	SHIELD
57	SHIELD	SHIELD
58	SHIELD	SHIELD

Connector No.	M174
Connector Name	AV CONTROL UNIT
Connector Type	TH32FY-NH



76	77	78	79	80	81	82	83	84	85	86	87	88	89	90	91
92	93	94	95	96	97	98	99	100	101	102	103	104	105	106	107

Terminal No.	Color of Wire	Signal Name [Specification]
76	LG	AV COMM (L)
77	SB	AV COMM (H)
78	LG	AV COMM (L)
79	SB	AV COMM (H)
80	P	CAN-L
81	L	CAN-H
82	V	SW GND
86	SHIELD	SHIELD
87	R	TEL VOICE SIGNAL (+)
88	L	TEL VOICE SIGNAL (-)
92	V	VEHICLE SPEED SIGNAL (θ-PULSE)
93	LG	PARKING BRAKE (With BOSE system)
93	G	PARKING BRAKE (Without BOSE system)
94	SB	REVERSE
95	G	IGNITION
96	W	DISK EJECT SIGNAL
102	W	AUX SOUND SIGNAL GND
103	B	AUX SOUND SIGNAL LH (+)
104	R	AUX SOUND SIGNAL RH (+)

Connector No.	M180
Connector Name	AV CONTROL UNIT
Connector Type	TH32FW-NH



61	62	63	64	65	66	67	68	69	70	71	72	73	74	75	76
77	78	79	80	81	82	83	84	85	86	87	88	89	90	91	92

Terminal No.	Color of Wire	Signal Name [Specification]
65	LG	PARKING BRAKE
67	BR	COMPOSITE IMAGE SIGNAL GND
68	GR	COMPOSITE IMAGE SIGNAL
71	SHIELD	SHIELD
72	B	MICROPHONE VCC
73	R	COMM (CONT->DISP)
74	P	CAN-L
75	LG	AV COMM (L)
78	LG	AV COMM (L)
79	R	ILLUMINATION SIGNAL
80	G	IGNITION
81	SB	REVERSE
82	V	VEHICLE SPEED SIGNAL (θ-PULSE)
83	SHIELD	SHIELD
87	W	MICROPHONE SIGNAL
88	SHIELD	SHIELD
89	G	COMM (DISP->CONT)
90	L	CAN-H
91	SB	AV COMM (H)
92	SB	AV COMM (H)

A
B
C
D
E
F
G
H
I
K
L
M
N
O
P

ADP

BCM (BODY CONTROL MODULE)

< ECU DIAGNOSIS INFORMATION >

BCM (BODY CONTROL MODULE)

Reference Value

INFOID:000000006882471

VALUES ON THE DIAGNOSIS TOOL

CONSULT-III MONITOR ITEM

Monitor Item	Condition	Value/Status
FR WIPER HI	Other than front wiper switch HI	Off
	Front wiper switch HI	On
FR WIPER LOW	Other than front wiper switch LO	Off
	Front wiper switch LO	On
FR WASHER SW	Front washer switch OFF	Off
	Front washer switch ON	On
FR WIPER INT	Other than front wiper switch INT/AUTO	Off
	Front wiper switch INT/AUTO	On
FR WIPER STOP	Front wiper is not in STOP position	Off
	Front wiper is in STOP position	On
INT VOLUME	Wiper intermittent dial is in a dial position 1 - 7	Wiper intermittent dial position
RR WIPER ON	Other than rear wiper switch ON	Off
	Rear wiper switch ON	On
RR WIPER INT	Other than rear wiper switch INT	Off
	Rear wiper switch INT	On
RR WASHER SW	Rear washer switch OFF	Off
	Rear washer switch ON	On
RR WIPER STOP	Rear wiper is in STOP position	Off
	Rear wiper is not in STOP position	On
TURN SIGNAL R	Other than turn signal switch RH	Off
	Turn signal switch RH	On
TURN SIGNAL L	Other than turn signal switch LH	Off
	Turn signal switch LH	On
TAIL LAMP SW	Other than lighting switch 1ST and 2ND	Off
	Lighting switch 1ST or 2ND	On
HI BEAM SW	Other than lighting switch HI	Off
	Lighting switch HI	On
HEAD LAMP SW 1	Other than lighting switch 2ND	Off
	Lighting switch 2ND	On
HEAD LAMP SW 2	Other than lighting switch 2ND	Off
	Lighting switch 2ND	On
PASSING SW	Other than lighting switch PASS	Off
	Lighting switch PASS	On
AUTO LIGHT SW	Other than lighting switch AUTO	Off
	Lighting switch AUTO	On
FR FOG SW	Front fog lamp switch OFF	Off
	Front fog lamp switch ON	On
RR FOG SW	NOTE: The item is indicated, but not monitored.	Off

BCM (BODY CONTROL MODULE)

< ECU DIAGNOSIS INFORMATION >

Monitor Item	Condition	Value/Status	
DOOR SW-DR	Driver door closed	Off	A
	Driver door opened	On	
DOOR SW-AS	Passenger door closed	Off	B
	Passenger door opened	On	
DOOR SW-RR	Rear RH door closed	Off	C
	Rear RH door opened	On	
DOOR SW-RL	Rear LH door closed	Off	D
	Rear LH door opened	On	
DOOR SW-BK	Back door closed	Off	E
	Back door opened	On	
CDL LOCK SW	Other than power door lock switch LOCK	Off	F
	Power door lock switch LOCK	On	
CDL UNLOCK SW	Other than power door lock switch UNLOCK	Off	G
	Power door lock switch UNLOCK	On	
KEY CYL LK-SW	Other than driver door key cylinder LOCK position	Off	H
	Driver door key cylinder LOCK position	On	
KEY CYL UN-SW	Other than driver door key cylinder UNLOCK position	Off	I
	Driver door key cylinder UNLOCK position	On	
KEY CYL SW-TR	NOTE: The item is indicated, but not monitored.	Off	
HAZARD SW	Hazard switch is OFF	Off	J
	Hazard switch is ON	On	
REAR DEF SW NOTE: For models with BOSE audio system this item is not monitored.	Rear window defogger switch OFF	Off	K
	Rear window defogger switch ON	On	ADP
TR CANCEL SW	NOTE: The item is indicated, but not monitored.	Off	
TR/BD OPEN SW	Back door opener switch OFF	Off	L
	While the back door opener switch is turned ON	On	
TRNK/HAT MNTR	NOTE: The item is indicated, but not monitored.	Off	
RKE-LOCK	LOCK button of Intelligent Key is not pressed	Off	M
	LOCK button of Intelligent Key is pressed	On	
RKE-UNLOCK	UNLOCK button of Intelligent Key is not pressed	Off	N
	UNLOCK button of Intelligent Key is pressed	On	
RKE-TR/BD	BACK DOOR OPEN button of Intelligent Key is not pressed	Off	O
	BACK DOOR OPEN button of Intelligent Key is pressed	On	
RKE-PANIC	PANIC button of Intelligent Key is not pressed	Off	P
	PANIC button of Intelligent Key is pressed	On	
RKE-P/W OPEN	UNLOCK button of Intelligent Key is not pressed	Off	
	UNLOCK button of Intelligent Key is pressed and held	On	
RKE-MODE CHG	LOCK/UNLOCK button of Intelligent Key is not pressed and held simultaneously	Off	
	LOCK/UNLOCK button of Intelligent Key is pressed and held simultaneously	On	

BCM (BODY CONTROL MODULE)

< ECU DIAGNOSIS INFORMATION >

Monitor Item	Condition	Value/Status
OPTICAL SENSOR	Bright outside of the vehicle	Close to 5 V
	Dark outside of the vehicle	Close to 0 V
REQ SW -DR	Driver door request switch is not pressed	Off
	Driver door request switch is pressed	On
REQ SW -AS	Passenger door request switch is not pressed	Off
	Passenger door request switch is pressed	On
REQ SW -RR	NOTE: The item is indicated, but not monitored.	Off
REQ SW -RR	NOTE: The item is indicated, but not monitored.	Off
REQ SW -BD/TR	Back door request switch is not pressed	Off
	Back door request switch is pressed	On
PUSH SW	Push-button ignition switch (push switch) is not pressed	Off
	Push-button ignition switch (push switch) is pressed	On
IGN RLY2 -F/B	Ignition switch in OFF or ACC position	Off
	Ignition switch in ON position	On
ACC RLY -F/B	NOTE: The item is indicated, but not monitored.	Off
CLUCH SW	NOTE: The item is indicated, but not monitored.	Off
BRAKE SW 1	The brake pedal is depressed when No. 7 fuse is blown	Off
	The brake pedal is not depressed when No. 7 fuse is blown, or No. 7 fuse is normal	On
BRAKE SW 2	The brake pedal is not depressed	Off
	Stop lamp switch 1 signal circuit is normal	On
DETE/CANCL SW	Selector lever in P position	Off
	Selector lever in any position other than P	On
SFT PN/N SW	Selector lever in any position other than P and N	Off
	Selector lever in P or N position	On
S/L -LOCK	NOTE: The item is indicated, but not monitored.	Off
S/L -UNLOCK	NOTE: The item is indicated, but not monitored.	Off
S/L RELAY-F/B	NOTE: The item is indicated, but not monitored.	Off
UNLK SEN -DR	Driver door is unlocked	Off
	Driver door is locked	On
PUSH SW -IPDM	Push-button ignition switch (push-switch) is not pressed	Off
	Push-button ignition switch (push-switch) is pressed	On
IGN RLY1 -F/B	Ignition switch in OFF or ACC position	Off
	Ignition switch in ON position	On
DETE SW -IPDM	Selector lever in any position other than P	Off
	Selector lever in P position	On
SFT PN -IPDM	Selector lever in any position other than P and N	Off
	Selector lever in P or N position	On
SFT P -MET	Selector lever in any position other than P	Off
	Selector lever in P position	On

BCM (BODY CONTROL MODULE)

< ECU DIAGNOSIS INFORMATION >

Monitor Item	Condition	Value/Status	
SFT N -MET	Selector lever in any position other than N	Off	A
	Selector lever in N position	On	
ENGINE STATE	Engine stopped	Stop	B
	While the engine stalls	Stall	
	At engine cranking	Crank	C
	Engine running	Run	
S/L LOCK-IPDM	NOTE: The item is indicated, but not monitored.	Off	D
S/L UNLK-IPDM	NOTE: The item is indicated, but not monitored.	Off	
S/L RELAY-REQ	NOTE: The item is indicated, but not monitored.	Off	E
VEH SPEED 1	While driving	Equivalent to speedometer reading	
VEH SPEED 2	While driving	Equivalent to speedometer reading	F
DOOR STAT-DR	Driver door is locked	LOCK	
	Wait with selective UNLOCK operation (5 seconds)	READY	G
	Driver door is unlocked	UNLOCK	
DOOR STAT-AS	Passenger door is locked	LOCK	H
	Wait with selective UNLOCK operation (5 seconds)	READY	
	Passenger door is unlocked	UNLOCK	
ID OK FLAG	Power supply position in LOCK position	Reset	I
	Power supply position in any position other than LOCK	Set	
PRMT ENG STRT	The engine start is prohibited	Reset	ADP
	The engine start is permitted	Set	
PRMT RKE STRT	NOTE: The item is indicated, but not monitored.	Reset	K
KEY SW -SLOT	Intelligent Key is not inserted into key slot	Off	
	Intelligent Key is inserted into key slot	On	
RKE OPE COUN1	During the operation of Intelligent Key	Operation frequency of Intelligent Key	L
RKE OPE COUN2	NOTE: The item is indicated, but not monitored.	—	M
CONFIRM ID ALL	The Intelligent Key ID that the key slot receives is not recognized by any Intelligent Key ID registered to BCM.	Yet	
	The Intelligent Key ID that the key slot receives is recognized by any Intelligent Key ID registered to BCM.	Done	N
CONFIRM ID4	The Intelligent Key ID that the key slot receives is not recognized by the fourth Intelligent Key ID registered to BCM.	Yet	O
	The Intelligent Key ID that the key slot receives is recognized by the fourth Intelligent Key ID registered to BCM.	Done	
CONFIRM ID3	The Intelligent Key ID that the key slot receives is not recognized by the third Intelligent Key ID registered to BCM.	Yet	P
	The Intelligent Key ID that the key slot receives is recognized by the third Intelligent Key ID registered to BCM.	Done	

BCM (BODY CONTROL MODULE)

< ECU DIAGNOSIS INFORMATION >

Monitor Item	Condition	Value/Status
CONFIRM ID2	The Intelligent Key ID that the key slot receives is not recognized by the second Intelligent Key ID registered to BCM.	Yet
	The Intelligent Key ID that the key slot receives is recognized by the second Intelligent Key ID registered to BCM.	Done
CONFIRM ID1	The Intelligent Key ID that the key slot receives is not recognized by the first Intelligent Key ID registered to BCM.	Yet
	The Intelligent Key ID that the key slot receives is recognized by the first Intelligent Key ID registered to BCM.	Done
TP 4	The ID of fourth Intelligent Key is not registered to BCM	Yet
	The ID of fourth Intelligent Key is registered to BCM	Done
TP 3	The ID of third Intelligent Key is not registered to BCM	Yet
	The ID of third Intelligent Key is registered to BCM	Done
TP 2	The ID of second Intelligent Key is not registered to BCM	Yet
	The ID of second Intelligent Key is registered to BCM	Done
TP 1	The ID of first Intelligent Key is not registered to BCM	Yet
	The ID of first Intelligent Key is registered to BCM	Done
AIR PRESS FL	Ignition switch ON (Only when the signal from the transmitter is received)	Air pressure of front LH tire
AIR PRESS FR	Ignition switch ON (Only when the signal from the transmitter is received)	Air pressure of front RH tire
AIR PRESS RR	Ignition switch ON (Only when the signal from the transmitter is received)	Air pressure of rear RH tire
AIR PRESS RL	Ignition switch ON (Only when the signal from the transmitter is received)	Air pressure of rear LH tire
ID REGST FL1	ID of front LH tire transmitter is registered	Done
	ID of front LH tire transmitter is not registered	Yet
ID REGST FR1	ID of front RH tire transmitter is registered	Done
	ID of front RH tire transmitter is not registered	Yet
ID REGST RR1	ID of rear RH tire transmitter is registered	Done
	ID of rear RH tire transmitter is not registered	Yet
ID REGST RL1	ID of rear LH tire transmitter is registered	Done
	ID of rear LH tire transmitter is not registered	Yet
WARNING LAMP	Tire pressure indicator OFF	Off
	Tire pressure indicator ON	On
BUZZER	Tire pressure warning alarm is not sounding	Off
	Tire pressure warning alarm is sounding	On

BCM (BODY CONTROL MODULE)

< ECU DIAGNOSIS INFORMATION >

TERMINAL LAYOUT

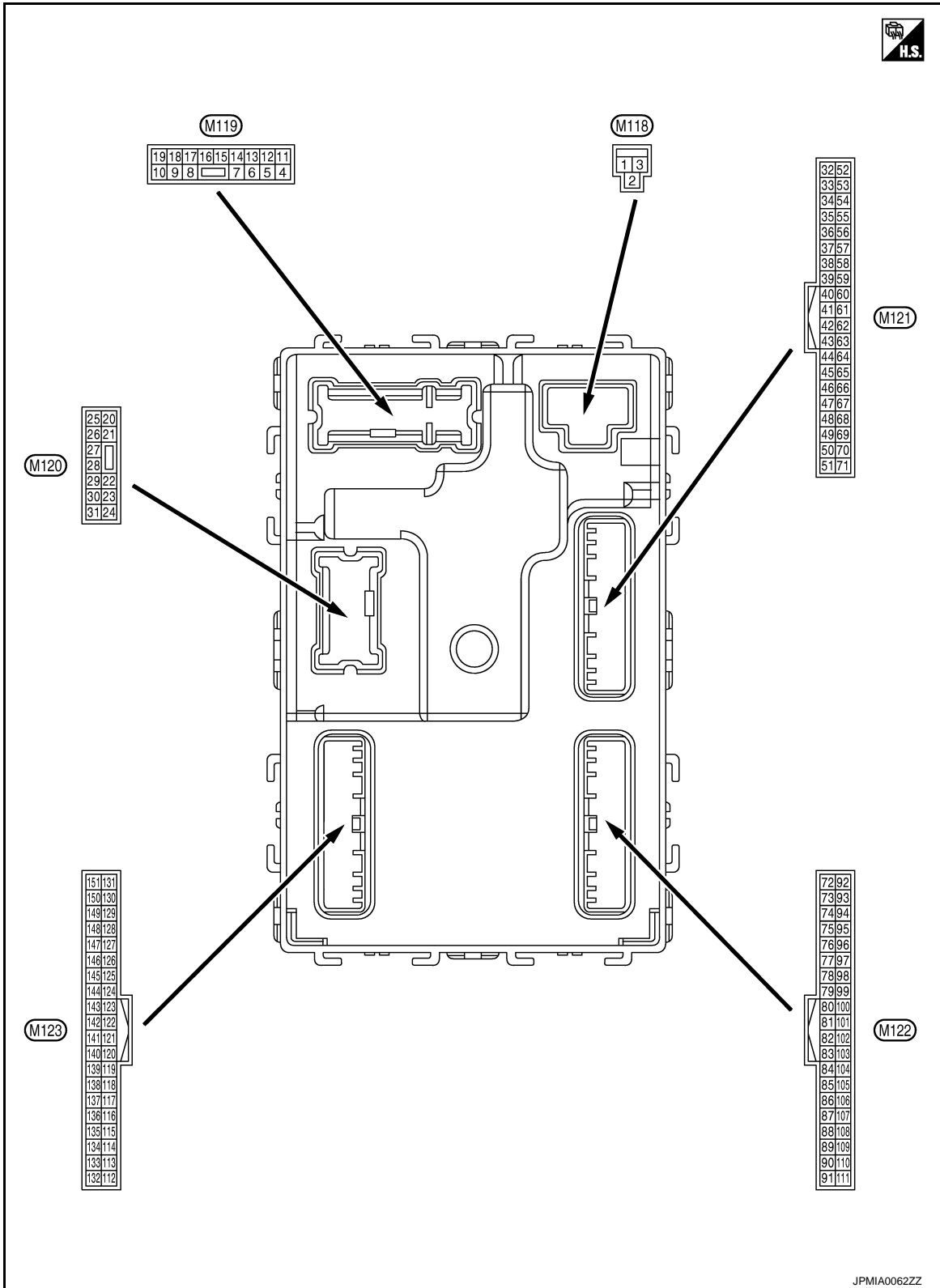

PHYSICAL VALUES

BCM (BODY CONTROL MODULE)

< ECU DIAGNOSIS INFORMATION >

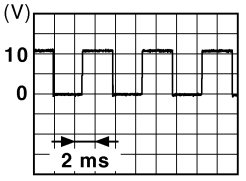
Terminal No. (Wire color)		Description		Condition		Value (Approx.)
		Signal name	Input/ Output			
+	-					
1 (W)	Ground	Battery power supply	Input	Ignition switch OFF		Battery voltage
2 (GR)	Ground	P/W power supply (BAT)	Output	Ignition switch OFF		Battery voltage
3 (L)	Ground	P/W power supply (RAP)	Output	Ignition switch ON		Battery voltage
4 (P)	Ground	Interior room lamp power supply	Output	Interior room lamp battery saver is activated. (Cuts the interior room lamp power supply)		0 V
				Interior room lamp battery saver is not activated. (Outputs the interior room lamp power supply)		Battery voltage
5 (G)	Ground	Passenger door UN- LOCK	Output	Passenger door	UNLOCK (Actuator is activated)	Battery voltage
					Other than UNLOCK (Actuator is not activated)	0 V
7 (Y)	Ground	Step lamp	Output	Step lamp	ON	0 V
						OFF
8 (V)	Ground	All doors LOCK	Output	All doors	LOCK (Actuator is activated)	Battery voltage
						Other than LOCK (Actuator is not activated)
9 (G)	Ground	Driver door UNLOCK	Output	Driver door	UNLOCK (Actuator is activated)	Battery voltage
						Other than UNLOCK (Actuator is not activated)
10 (P)	Ground	Rear RH door and rear LH door UN- LOCK	Output	Rear RH door and rear LH door	UNLOCK (Actuator is activated)	Battery voltage
						Other than UNLOCK (Actuator is not activated)
11 (LG)	Ground	Battery power supply	Input	Ignition switch OFF		Battery voltage
13 (B)	Ground	Ground	—	Ignition switch ON		0 V
14 (O)	Ground	Push-button ignition switch illumination ground	Output	Tail lamp	OFF	0 V
					ON	<p style="text-align: center;">NOTE: When the illumination brightening/dimming level is in the neutral position</p>  <p style="text-align: right; font-size: small;">JSNIA0010GB</p>
15 (L)	Ground	ACC indicator lamp	Output	Ignition switch	OFF (LOCK and ON indicator lamps are not illuminated.)	Battery voltage
						ACC

BCM (BODY CONTROL MODULE)

< ECU DIAGNOSIS INFORMATION >

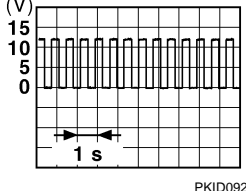
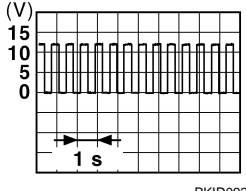
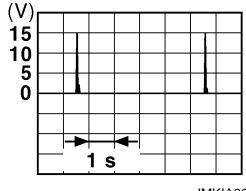
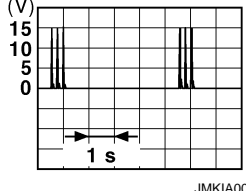
Terminal No. (Wire color)		Description		Condition	Value (Approx.)
+	-	Signal name	Input/ Output		
17 (G)	Ground	Turn signal RH	Output	Ignition switch ON	Turn signal switch OFF 0 V
				Turn signal switch RH	 6.5 V
18 (BR)	Ground	Turn signal LH	Output	Ignition switch ON	Turn signal switch OFF 0 V
				Turn signal switch LH	 6.5 V
19 (Y)	Ground	Room lamp timer control	Output	Interior room lamp	OFF Battery voltage
				ON	0 V
23 (BR)	Ground	Back door open	Output	Back door	OPEN (Back door opener actuator is activated) Battery voltage
				Other than OPEN (Back door opener actuator is not activated)	0 V
26 (G)	Ground	Rear wiper	Output	Rear wiper	OFF (Stopped) 0 V
				ON (Operated)	Battery voltage
34 (B)	Ground	Luggage room anten- na (-)	Output	Ignition switch OFF	
				When Intelligent Key is not in the passenger compart- ment	

A
B
C
D
E
F
G
H
I
ADP
K
L
M
N
O
P

BCM (BODY CONTROL MODULE)

< ECU DIAGNOSIS INFORMATION >

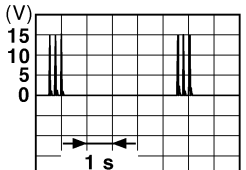
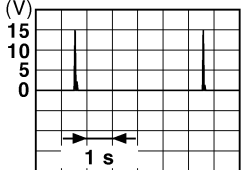
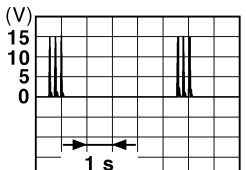
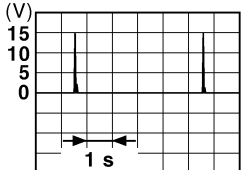
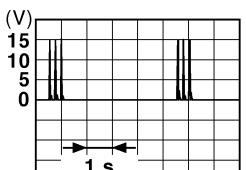
Terminal No. (Wire color)		Description		Condition	Value (Approx.)
+	-	Signal name	Input/ Output		
35 (W)	Ground	Luggage room antenna (+)	Output		
				When Intelligent Key is not in the passenger compartment	 <p style="text-align: right; font-size: small;">JMkia0063GB</p>
38 (L)	Ground	Rear bumper antenna (-)	Output	When the back door request switch is operated with ignition switch OFF	 <p style="text-align: right; font-size: small;">JMkia0062GB</p>
				When Intelligent Key is not in the antenna detection area	 <p style="text-align: right; font-size: small;">JMkia0063GB</p>
39 (BR)	Ground	Rear bumper antenna (+)	Output	When the back door request switch is operated with ignition switch OFF	 <p style="text-align: right; font-size: small;">JMkia0062GB</p>
				When Intelligent Key is not in the antenna detection area	 <p style="text-align: right; font-size: small;">JMkia0063GB</p>
47 (L)	Ground	Ignition relay (IPDM E/R) control	Output	Ignition switch	Battery voltage
				OFF or ACC	0 V
				ON	0 V

BCM (BODY CONTROL MODULE)

< ECU DIAGNOSIS INFORMATION >

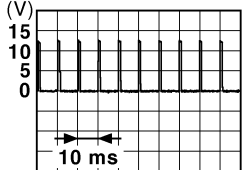
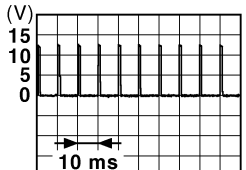
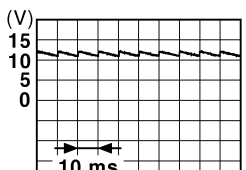
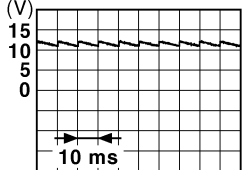
Terminal No. (Wire color)		Description		Condition		Value (Approx.)
		Signal name	Input/ Output			
+	-					
52 (R)	Ground	Starter relay control	Output	Ignition switch ON	When selector lever is in P or N position	Battery voltage
					When selector lever is not in P or N position	0.3 V
				Ignition switch OFF		0 V
60 (BR)	Ground	Push-button ignition switch (push switch)	Input	Push-button igni- tion switch (push switch)	Pressed	0 V
					Not pressed	Battery voltage
61 (R)	Ground	Back door request switch	Input	Back door re- quest switch	ON (Pressed)	0 V
					OFF (Not pressed)	 <p style="text-align: right; font-size: small;">JPMA0016GB</p>
64 (GR)	Ground	Warning buzzer	Output	Warning buzzer	Sounding	0 V
					Not sounding	Battery voltage
65 (O)	Ground	Rear wiper stop posi- tion	Input	Rear wiper	In stop position	 <p style="text-align: right; font-size: small;">JPMA0016GB</p>
					Not in stop position	0 V
66 (Y)	Ground	Back door switch	Input	Back door switch	OFF (When back door closes)	 <p style="text-align: right; font-size: small;">JPMA0011GB</p>
					ON (When back door opens)	0 V
67 (LG)	Ground	Back door opener switch	Input	Back door opener switch	Pressed	0 V
					Not pressed	 <p style="text-align: right; font-size: small;">JPMA0011GB</p>

A
B
C
D
E
F
G
H
I
K
L
M
N
O
P

ADP

BCM (BODY CONTROL MODULE)

< ECU DIAGNOSIS INFORMATION >

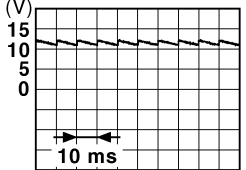
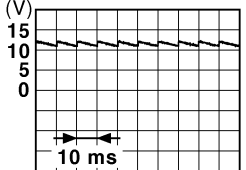
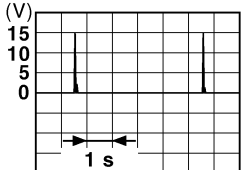
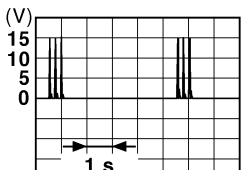
Terminal No. (Wire color)		Description		Condition	Value (Approx.)	
+	-	Signal name	Input/ Output			
68 (W)	Ground	Rear RH door switch	Input	Rear RH door switch	OFF (When rear RH door closes)	 <p style="text-align: right; font-size: small;">JPMIA0011GB</p> <p style="text-align: center;">11.8 V</p>
				Rear RH door switch	ON (When rear RH door opens)	0 V
69 (R)	Ground	Rear LH door switch	Input	Rear LH door switch	OFF (When rear LH door closes)	 <p style="text-align: right; font-size: small;">JPMIA0011GB</p> <p style="text-align: center;">11.8 V</p>
				Rear LH door switch	ON (When rear LH door opens)	0 V
72 (B)	Ground	Room antenna (-) (Center console)	Output	Ignition switch OFF	When Intelligent Key is in the passenger compart- ment	 <p style="text-align: right; font-size: small;">JMKIA0062GB</p>
				Ignition switch OFF	When Intelligent Key is not in the passenger compart- ment	 <p style="text-align: right; font-size: small;">JMKIA0063GB</p>

BCM (BODY CONTROL MODULE)

< ECU DIAGNOSIS INFORMATION >

Terminal No. (Wire color)		Description		Condition	Value (Approx.)
		Signal name	Input/ Output		
+	-				
73 (W)	Ground	Room antenna (+) (Center console)	Output	Ignition switch OFF	<p style="text-align: right; font-size: small;">JMKIA0062GB</p>
				When Intelligent Key is not in the passenger compart- ment	<p style="text-align: right; font-size: small;">JMKIA0063GB</p>
74 (Y)	Ground	Passenger door an- tenna (-)	Output	When the pas- senger door re- quest switch is operated with ig- nition switch OFF	<p style="text-align: right; font-size: small;">JMKIA0062GB</p>
				When Intelligent Key is not in the antenna detection area	<p style="text-align: right; font-size: small;">JMKIA0063GB</p>
75 (LG)	Ground	Passenger door an- tenna (+)	Output	When the pas- senger door re- quest switch is operated with ig- nition switch OFF	<p style="text-align: right; font-size: small;">JMKIA0062GB</p>
				When Intelligent Key is not in the antenna detection area	<p style="text-align: right; font-size: small;">JMKIA0063GB</p>

A
B
C
D
E
F
G
H
I
K
L
M
N
O
P

ADP

BCM (BODY CONTROL MODULE)

< ECU DIAGNOSIS INFORMATION >

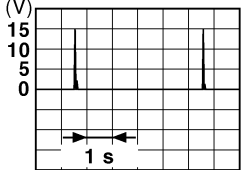
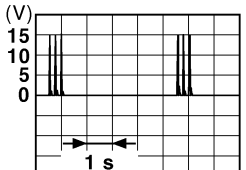
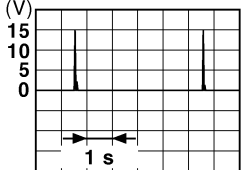
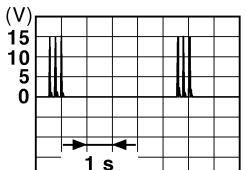
Terminal No. (Wire color)		Description		Condition	Value (Approx.)	
+	-	Signal name	Input/ Output			
76 (V)	Ground	Driver door antenna (-)	Output	When the driver door request switch is operated with ignition switch OFF	 <p style="text-align: right; font-size: small;">JMKIA0062GB</p>	
				When Intelligent Key is not in the antenna detection area	 <p style="text-align: right; font-size: small;">JMKIA0063GB</p>	
77 (P)	Ground	Driver door antenna (+)	Output	When the driver door request switch is operated with ignition switch OFF	 <p style="text-align: right; font-size: small;">JMKIA0062GB</p>	
				When Intelligent Key is not in the antenna detection area	 <p style="text-align: right; font-size: small;">JMKIA0063GB</p>	
80 (SB)	Ground	NATS antenna amp.	Input/ Output	During waiting	Ignition switch is pressed while inserting Intelligent Key into the key slot.	Just after pressing ignition switch. Pointer of tester should move.
81 (O)	Ground	NATS antenna amp.	Input/ Output	During waiting	Ignition switch is pressed while inserting Intelligent Key into the key slot.	Just after pressing ignition switch. Pointer of tester should move.
82 (BR)	Ground	Ignition relay [fuse block (J/B)] control	Output	Ignition switch	OFF or ACC	0 V
					ON	Battery voltage

BCM (BODY CONTROL MODULE)

< ECU DIAGNOSIS INFORMATION >

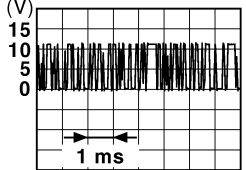
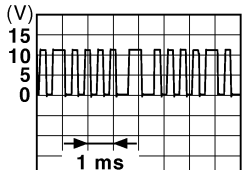
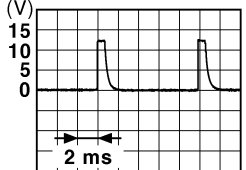
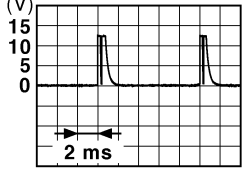
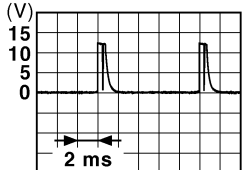

Terminal No. (Wire color)		Description		Condition	Value (Approx.)	
		Signal name	Input/ Output			
+	-					
83 (P)	Ground	Remote keyless entry receiver communication	Input/ Output	During waiting	 <p style="text-align: right; font-size: small;">JMKIA0064GB</p>	
				When operating either button on Intelligent Key	 <p style="text-align: right; font-size: small;">JMKIA0065GB</p>	
87 (R)	Ground	Combination switch INPUT 5	Input	Combination switch	All switches OFF (Wiper intermittent dial 4)	 <p style="text-align: right; font-size: small;">JPMIA0041GB</p> <p style="text-align: center;">1.4 V</p>
					Front fog lamp switch ON (Wiper intermittent dial 4)	 <p style="text-align: right; font-size: small;">JPMIA0037GB</p> <p style="text-align: center;">1.3 V</p>
					Rear wiper switch ON (Wiper intermittent dial 4)	 <p style="text-align: right; font-size: small;">JPMIA0039GB</p> <p style="text-align: center;">1.3 V</p>
					Any of the conditions below with all switches OFF	<ul style="list-style-type: none"> • Wiper intermittent dial 1 • Wiper intermittent dial 2 • Wiper intermittent dial 6 • Wiper intermittent dial 7

A
B
C
D
E
F
G
H
I
K
L
M
N
O
P

ADP

BCM (BODY CONTROL MODULE)

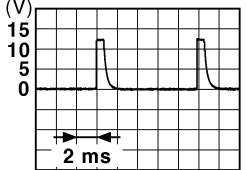
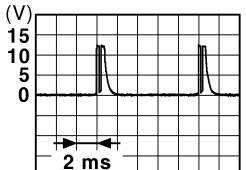
< ECU DIAGNOSIS INFORMATION >

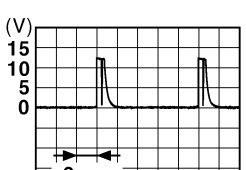
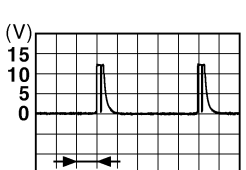
Terminal No. (Wire color)		Description		Condition	Value (Approx.)	
+	-	Signal name	Input/ Output			
88 (GR)	Ground	Combination switch INPUT 3	Input	Combination switch	All switches OFF (Wiper intermittent dial 4)	 <p style="text-align: right; font-size: small;">JPMIA0041GB</p> <p style="text-align: center;">1.4 V</p>
					Lighting switch HI (Wiper intermittent dial 4)	 <p style="text-align: right; font-size: small;">JPMIA0036GB</p> <p style="text-align: center;">1.3 V</p>
					Lighting switch 2ND (Wiper intermittent dial 4)	 <p style="text-align: right; font-size: small;">JPMIA0037GB</p> <p style="text-align: center;">1.3 V</p>
					Rear washer switch ON (Wiper intermittent dial 4)	 <p style="text-align: right; font-size: small;">JPMIA0039GB</p> <p style="text-align: center;">1.3 V</p>
					Any of the conditions below with all switches OFF	<ul style="list-style-type: none"> • Wiper intermittent dial 1 • Wiper intermittent dial 2 • Wiper intermittent dial 3  <p style="text-align: right; font-size: small;">JPMIA0040GB</p> <p style="text-align: center;">1.3 V</p>
90 (P)	Ground	CAN - L	Input/ Output	—	—	
91 (L)	Ground	CAN - H	Input/ Output	—	—	

BCM (BODY CONTROL MODULE)

< ECU DIAGNOSIS INFORMATION >

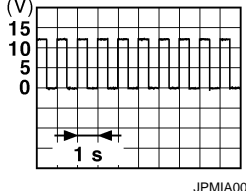
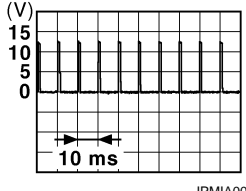
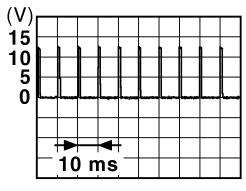

Terminal No. (Wire color)		Description		Condition	Value (Approx.)	
+	-	Signal name	Input/ Output			
92 (R)	Ground	Key slot illumination	Output	Key slot illumination	OFF	0 V
					Blinking	 6.5 V
					ON	Battery voltage
93 (P)	Ground	ON indicator lamp	Output	Ignition switch	OFF (LOCK and ACC indicator lamps are not illuminated.)	Battery voltage
					ON	0 V
95 (L)	Ground	ACC relay control	Output	Ignition switch	OFF	0 V
					ACC or ON	Battery voltage
96 (Y)	Ground	CVT shift selector (detention switch) power supply	Output	—	Battery voltage	
99 (V)	Ground	Selector lever P position switch	Input	Selector lever	P position	0 V
					Any position other than P	Battery voltage
100 (P)	Ground	Passenger door request switch	Input	Passenger door request switch	ON (Pressed)	0 V
					OFF (Not pressed)	 1.0 V
101 (W)	Ground	Driver door request switch	Input	Driver door request switch	ON (Pressed)	0 V
					OFF (Not pressed)	 1.0 V
102 (Y)	Ground	Blower fan motor relay control	Output	Ignition switch	OFF or ACC	0 V
					ON	Battery voltage
103 (L)	Ground	Remote keyless entry receiver power supply	Output	Ignition switch OFF	Battery voltage	

A
B
C
D
E
F
G
H
I
K
L
M
N
O
P

ADP



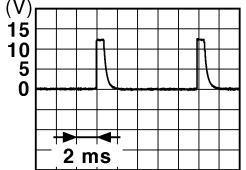

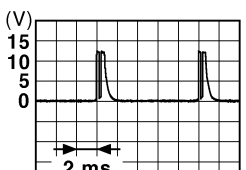
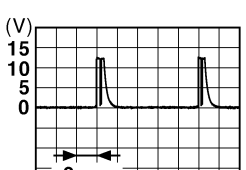
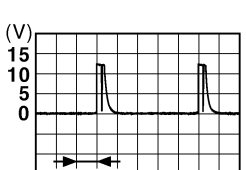
BCM (BODY CONTROL MODULE)

< ECU DIAGNOSIS INFORMATION >

Terminal No. (Wire color)		Description		Condition	Value (Approx.)	
+	-	Signal name	Input/ Output			
107 (O)	Ground	Combination switch INPUT 1	Input	Combination switch (Wiper intermittent dial 4)	All switches OFF	 <p style="text-align: right;">JPMIA0041GB</p> <p style="text-align: center;">1.4 V</p>
					Turn signal switch LH	 <p style="text-align: right;">JPMIA0037GB</p> <p style="text-align: center;">1.3 V</p>
					Turn signal switch RH	 <p style="text-align: right;">JPMIA0036GB</p> <p style="text-align: center;">1.3 V</p>
					Front wiper switch LO	 <p style="text-align: right;">JPMIA0038GB</p> <p style="text-align: center;">1.3 V</p>
					Front washer switch ON	 <p style="text-align: right;">JPMIA0039GB</p> <p style="text-align: center;">1.3 V</p>

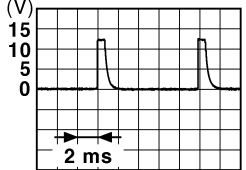
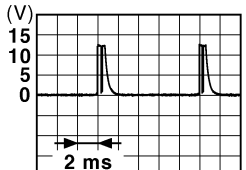
BCM (BODY CONTROL MODULE)

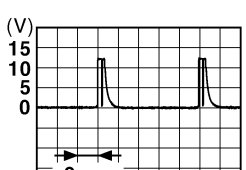

< ECU DIAGNOSIS INFORMATION >

Terminal No. (Wire color)		Description		Condition	Value (Approx.)	
		Signal name	Input/ Output			
+	-					
108 (P)	Ground	Combination switch INPUT 4	Input	Combination switch	All switches OFF (Wiper intermittent dial 4)	 1.4 V
					Lighting switch AUTO (Wiper intermittent dial 4)	 1.3 V
					Lighting switch 1ST (Wiper intermittent dial 4)	 1.3 V
					Rear wiper switch INT (Wiper intermittent dial 4)	 1.3 V
					Any of the conditions below with all switches OFF	 1.3 V

A
B
C
D
E
F
G
H
I
ADP
K
L
M
N
O
P

BCM (BODY CONTROL MODULE)

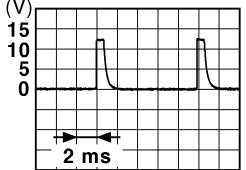
< ECU DIAGNOSIS INFORMATION >

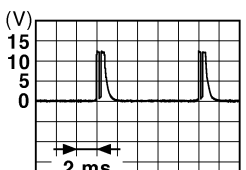
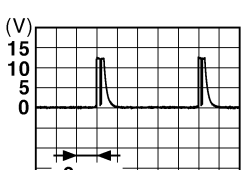
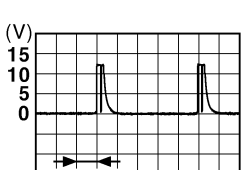
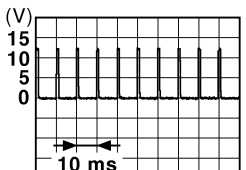
Terminal No. (Wire color)		Description		Condition	Value (Approx.)	
+	-	Signal name	Input/ Output			
109 (SB)	Ground	Combination switch INPUT 2	Input	Combination switch (Wiper intermittent dial 4)	All switches OFF	 <p style="text-align: right;">1.4 V</p>
					Lighting switch PASS	 <p style="text-align: right;">1.3 V</p>
					Lighting switch 2ND	 <p style="text-align: right;">1.3 V</p>
					Front wiper switch INT/ AUTO	 <p style="text-align: right;">1.3 V</p>
					Front wiper switch HI	 <p style="text-align: right;">1.3 V</p>
					ON	0 V
110 (G)	Ground	Hazard switch	Input	Hazard switch	 <p style="text-align: right;">1.1 V</p>	
				OFF		

BCM (BODY CONTROL MODULE)

< ECU DIAGNOSIS INFORMATION >

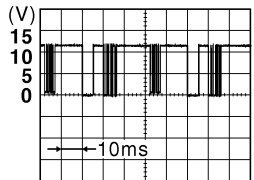
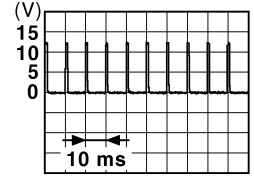
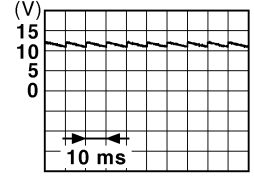
Terminal No. (Wire color)		Description		Condition	Value (Approx.)
		Signal name	Input/ Output		
+	-				
112 (R)	Ground	Rain sensor serial link	Input/ Output	Ignition switch ON	 8.7 V
113 (O)	Ground	Optical sensor	Input	Ignition switch ON	When bright outside of the vehicle Close to 5 V
				—	When dark outside of the vehicle Close to 0 V
116 (GR)	Ground	Stop lamp switch 1	Input	—	Battery voltage
118 (L)	Ground	Stop lamp switch 2	Input	Stop lamp switch	OFF (Brake pedal is not depressed) 0 V
				—	ON (Brake pedal is depressed) Battery voltage
119 (W)	Ground	Front door lock assembly driver side (Unlock sensor)	Input	Driver door	 1.1 V
				—	UNLOCK status (unlock sensor switch ON) 0 V
121 (Y)	Ground	Key slot switch	Input	When Intelligent Key is inserted into key slot	Battery voltage
				—	When Intelligent Key is not inserted into key slot 0 V
123 (G)	Ground	IGN feedback	Input	Ignition switch	OFF or ACC 0 V
				—	ON Battery voltage
124 (R)	Ground	Passenger door switch	Input	Passenger door switch	 11.8 V
				—	ON (When passenger door opens) 0 V

A
B
C
D
E
F
G
H
I
K
L
M
N
O
P

ADP

BCM (BODY CONTROL MODULE)

< ECU DIAGNOSIS INFORMATION >

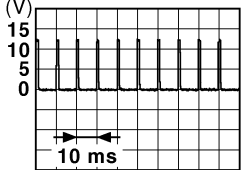
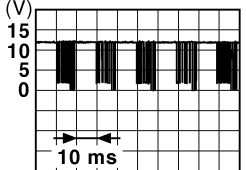
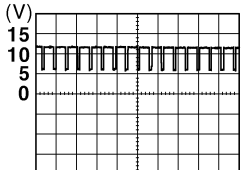
Terminal No. (Wire color)		Description		Condition		Value (Approx.)
+	-	Signal name	Input/ Output			
130 (BR)	Ground	Rear window defogger switch	Input	Ignition switch ON	Rear window defogger switch OFF	 1.1 V
				Rear window defogger switch ON		0 V
132 (G)	Ground	Power window switch communication	Input/ Output	Ignition switch ON		 10.2 V
				Ignition switch OFF or ACC		Battery voltage
133 (W)	Ground	Push-button ignition switch illumination	Output	Push-button ignition switch illumination	ON (When tail lamps OFF)	9.5 V
					ON (When tail lamps ON)	<p style="text-align: center;">NOTE: The pulse width of this wave is varied by the illumination brightening/dimming level.</p>  9.5 V
134 (R)	Ground	LOCK indicator lamp	Output	LOCK indicator lamp	OFF (ACC and ON indicator lamps are not illuminated.)	Battery voltage
					ON	0 V
137 (P)	Ground	Receiver and sensor ground	Input	Ignition switch ON		0 V
138 (V)	Ground	Receiver and sensor power supply	Output	Ignition switch	OFF	0 V
					ACC or ON	5.0 V

BCM (BODY CONTROL MODULE)

< ECU DIAGNOSIS INFORMATION >

Terminal No. (Wire color)		Description		Condition	Value (Approx.)
+	-	Signal name	Input/ Output		
139 (O)	Ground	Tire pressure receiver communication	Input/ Output	Ignition switch ON	<p style="text-align: right;">OCC3881D</p>
				When receiving the signal from the transmitter	<p style="text-align: right;">OCC3880D</p>
140 (GR)	Ground	Selector lever P/N position	Input	Selector lever	P or N position Battery voltage
				Except P and N positions	0 V
141 (O)	Ground	Security indicator	Output	Security indicator	ON 0 V
				Blinking	<p style="text-align: right;">JPMA0014GB</p> <p style="text-align: center;">11.3 V</p>
				OFF	Battery voltage
142 (L)	Ground	Combination switch OUTPUT 5	Output	Combination switch (Wiper intermittent dial 4)	All switches OFF 0 V
				Lighting switch 1ST	<p style="text-align: right;">JPMA0031GB</p> <p style="text-align: center;">10.7 V</p>
				Lighting switch HI	
				Lighting switch 2ND	
Turn signal switch RH	0 V				
143 (W)	Ground	Combination switch OUTPUT 1	Output	Combination switch	All switches OFF (Wiper intermittent dial 4) 0 V
				Front wiper switch HI (Wiper intermittent dial 4)	<p style="text-align: right;">JPMA0032GB</p> <p style="text-align: center;">10.7 V</p>
				Rear wiper switch INT (Wiper intermittent dial 4)	
				Any of the conditions below with all switches OFF <ul style="list-style-type: none"> • Wiper intermittent dial 1 • Wiper intermittent dial 2 • Wiper intermittent dial 3 • Wiper intermittent dial 6 • Wiper intermittent dial 7 	

A

B

C

D

E

F

G

H

I

ADP

K

L

M

N

O

P

BCM (BODY CONTROL MODULE)

< ECU DIAGNOSIS INFORMATION >

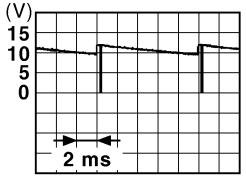
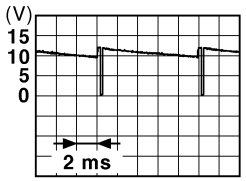
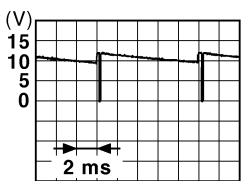
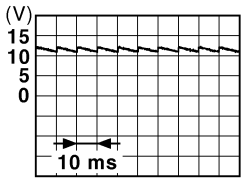
Terminal No. (Wire color)		Description		Condition	Value (Approx.)	
+	-	Signal name	Input/ Output			
144 (P)	Ground	Combination switch OUTPUT 2	Output	Combination switch	All switches OFF (Wiper intermittent dial 4)	0 V
					Front washer switch ON (Wiper intermittent dial 4)	
					Rear wiper switch ON (Wiper intermittent dial 4)	
					Rear washer switch ON (Wiper intermittent dial 4)	
					Any of the conditions below with all switches OFF <ul style="list-style-type: none"> • Wiper intermittent dial 1 • Wiper intermittent dial 5 • Wiper intermittent dial 6 	
145 (V)	Ground	Combination switch OUTPUT 3	Output	Combination switch (Wiper intermit- tent dial 4)	All switches OFF	0 V
					Front wiper switch INT/ AUTO	
					Front wiper switch LO	
					Lighting switch AUTO	
146 (Y)	Ground	Combination switch OUTPUT 4	Output	Combination switch (Wiper intermit- tent dial 4)	All switches OFF	0 V
					Front fog lamp switch ON	
					Lighting switch 2ND	
					Lighting switch PASS	
					Turn signal switch LH	
150 (SB)	Ground	Driver door switch	Input	Driver door switch	OFF (When driver door closes)	 11.8 V
					ON (When driver door opens)	0 V
151 (G)	Ground	Rear window defog- ger relay control	Output	Rear window de- fogger	Active	0 V
					Not activated	Battery voltage

BCM (BODY CONTROL MODULE)

< ECU DIAGNOSIS INFORMATION >

Wiring Diagram - BCM -

INFOID:000000006882472

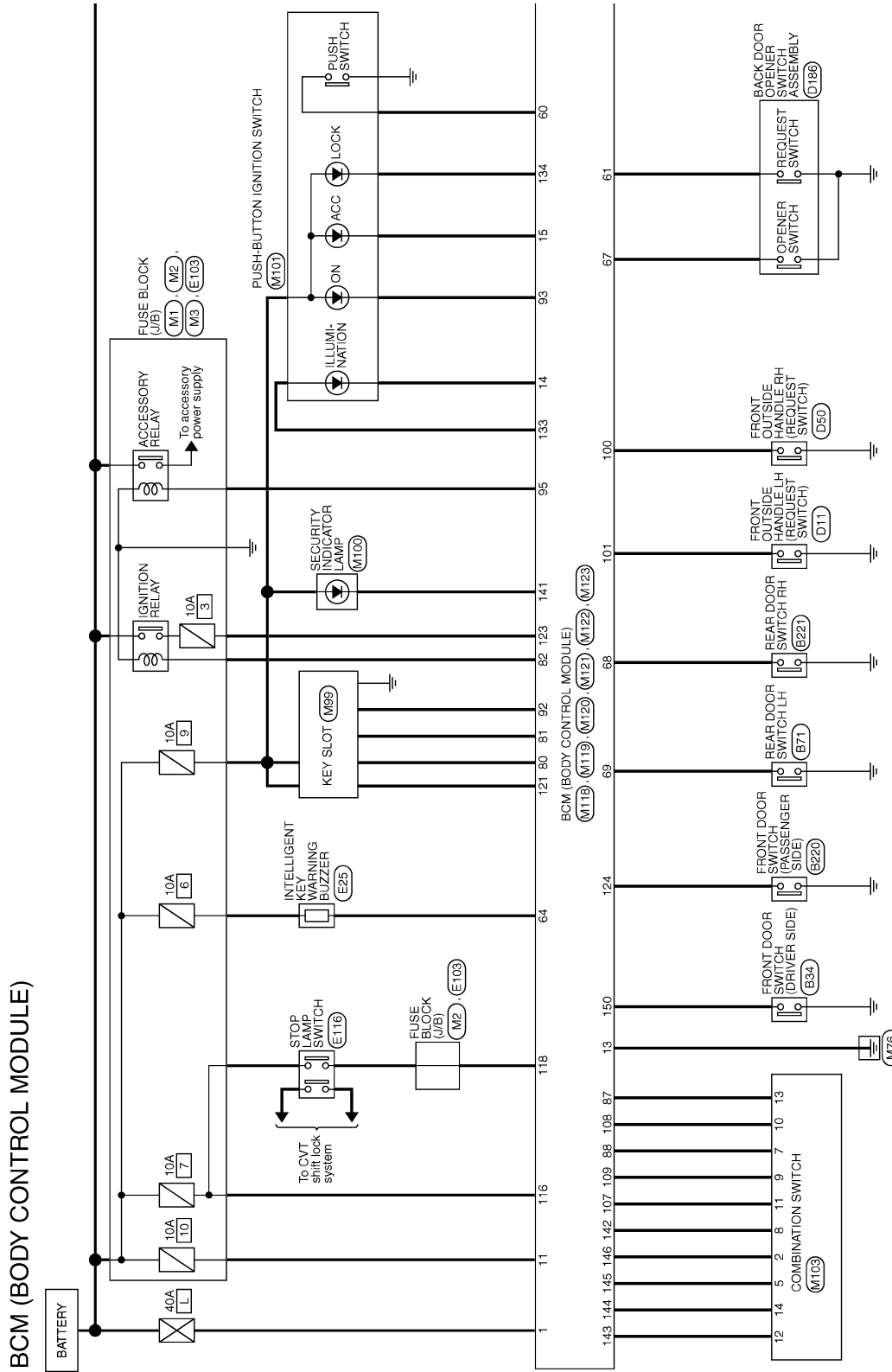

2010/09/06

JCMWN0014GB

A
B
C
D
E
F
G
H
I
ADP
K
L
M
N
O
P

BCM (BODY CONTROL MODULE)

< ECU DIAGNOSIS INFORMATION >

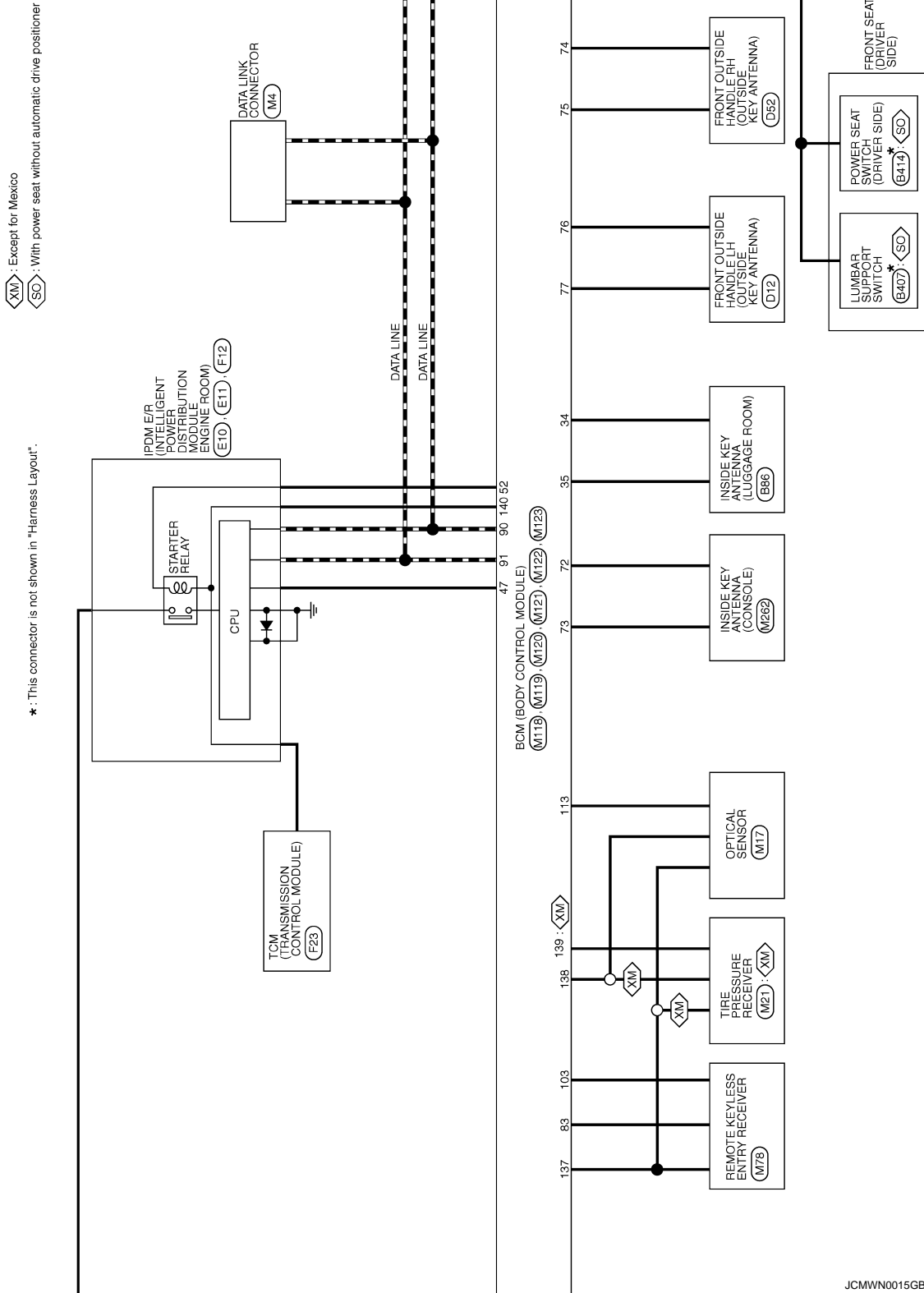

JCMWN0015GB

BCM (BODY CONTROL MODULE)

< ECU DIAGNOSIS INFORMATION >

- ◊NV: With navigation system
- ◊ON: Without navigation system
- ◊RF: With sunroof
- ◊PM: With automatic drive positioner
- ◊SO: With power seat without automatic drive positioner
- ◊AB: With automatic back door
- ◊WD: With color display

*: This connector is not shown in "Harness Layout".

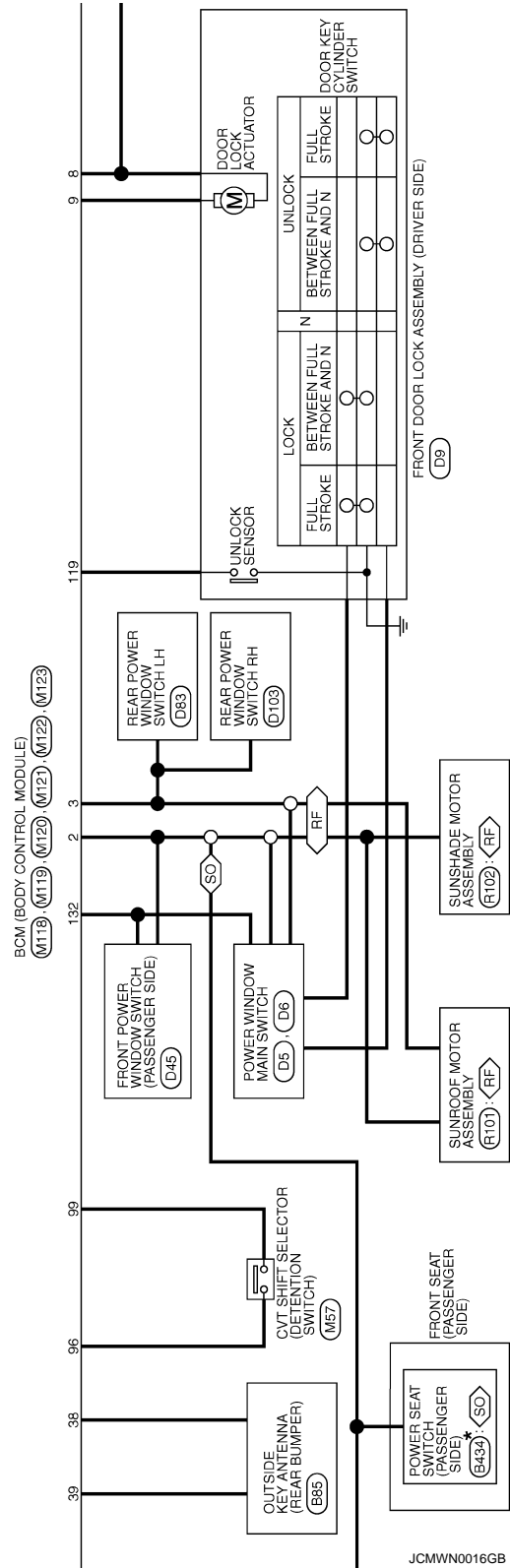
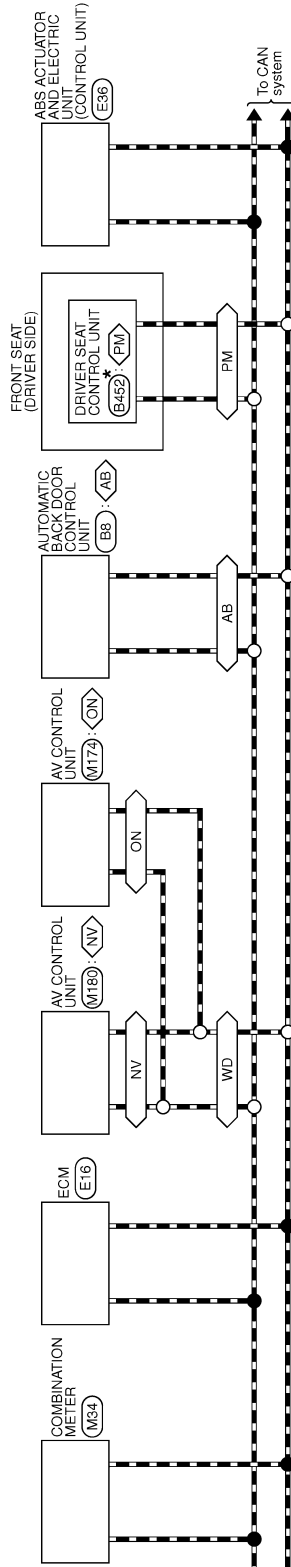

A
B
C
D
E
F
G
H
I
ADP
K
L
M
N
O
P

BCM (BODY CONTROL MODULE)

< ECU DIAGNOSIS INFORMATION >

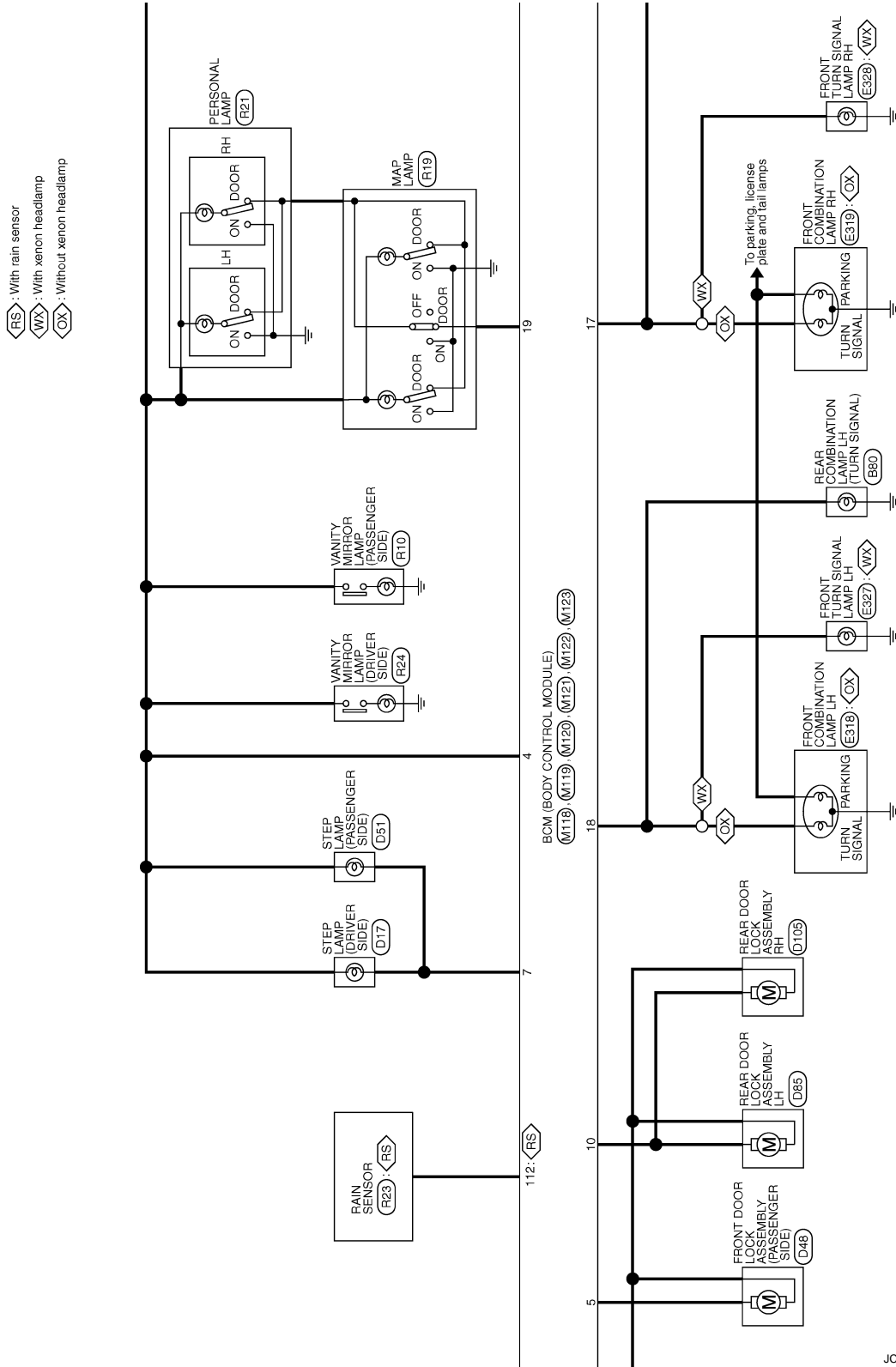

JCMWN0017GB

BCM (BODY CONTROL MODULE)

< ECU DIAGNOSIS INFORMATION >

◊AB◊ : With automatic back door
 ◊OA◊ : Without automatic back door

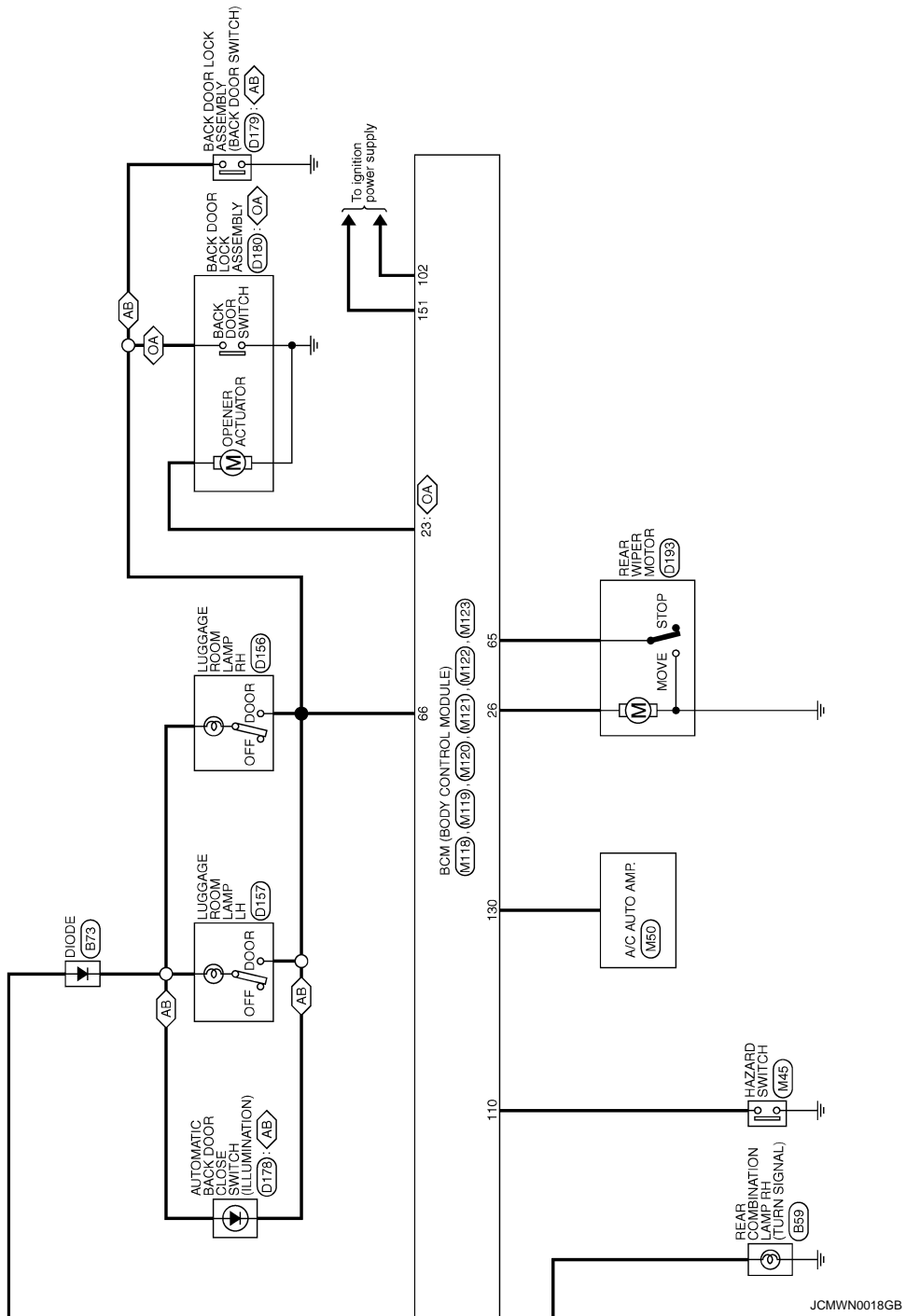

A
B
C
D
E
F
G
H
I
ADP
K
L
M
N
O
P

BCM (BODY CONTROL MODULE)

< ECU DIAGNOSIS INFORMATION >

BCM (BODY CONTROL MODULE)

Connector No.	M103
Connector Name	COMBINATION SWITCH
Connector Type	TH16FW-NH

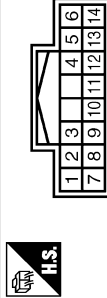

Terminal No.	Color of Wire	Signal Name [Specification]
1	G	RR
2	Y	OUTPUT 4
3	O	FR
4	W	IGN
5	V	OUTPUT 3
6	B	GND
7	GR	INPUT 3
8	L	OUTPUT 5
9	SB	INPUT 2
10	P	INPUT 4
11	O	INPUT 1
12	W	OUTPUT 1
13	R	INPUT 5
14	P	OUTPUT 2

Connector No.	M118
Connector Name	BCM (BODY CONTROL MODULE)
Connector Type	M03FB-LC



Terminal No.	Color of Wire	Signal Name [Specification]
1	W	BAT (E/L)
2	GR	POWER WINDOW POWER SUPPLY (BAT)
3	L	POWER WINDOW POWER SUPPLY (RAP)

Connector No.	M119
Connector Name	BCM (BODY CONTROL MODULE)
Connector Type	NS16FW-CS

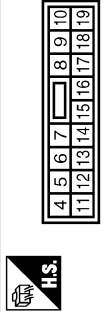

Terminal No.	Color of Wire	Signal Name [Specification]
4	P	INTERIOR ROOM LAMP POWER SUPPLY
5	G	PASSENGER DOOR UNLOCK OUTPUT
7	Y	STEP LAMP OUTPUT
8	V	ALL DOOR FUEL LID LOCK OUTPUT
9	G	DRIVER DOOR FUEL LID UNLOCK OUTPUT
10	P	REAR DOOR UNLOCK OUTPUT
11	LG	BAT (FUSE)
13	B	GND
14	O	PUSH-BUTTON IGNITION SW ILL GND
15	L	ACC IND
17	G	TURN SIGNAL RH
18	BR	TURN SIGNAL LH
19	Y	ROOM LAMP TIMER CONTROL

Connector No.	M120
Connector Name	BCM (BODY CONTROL MODULE)
Connector Type	NS12FW-CS

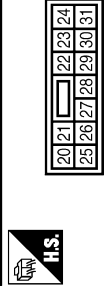

Terminal No.	Color of Wire	Signal Name [Specification]
23	BR	BACK DOOR OPEN OUTPUT
26	G	REAR WIPER OUTPUT

Connector No.	M121
Connector Name	BCM (BODY CONTROL MODULE)
Connector Type	TH40FY-NH

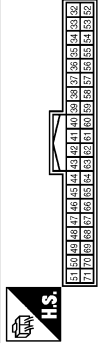

Terminal No.	Color of Wire	Signal Name [Specification]
34	B	LUGGAGE ROOM ANT 1-
35	W	LUGGAGE ROOM ANT 1+
38	L	REAR BUMPER ANT-
39	BR	REAR BUMPER ANT+
47	L	IGN RELAY FROM E/R CONT
52	R	STARTER RELAY CONT
60	BR	EXTRA IN 2
61	R	BACK DOOR OPENER REQUEST SW
64	GR	REQUEST SW BUZZER
65	O	REAR WIPER STOP POSITION
66	Y	BACK DOOR SW
67	LG	BACK DOOR OPENER SW
68	W	REAR RH DOOR SW
69	R	REAR LH DOOR SW

Connector No.	M122
Connector Name	BCM (BODY CONTROL MODULE)
Connector Type	TH40FB-NH

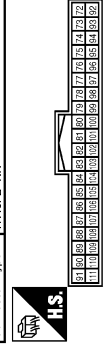

Terminal No.	Color of Wire	Signal Name [Specification]
72	B	ROOM ANT 2-
73	W	ROOM ANT 2+
74	Y	PASSENGER DOOR ANT-
75	LG	PASSENGER DOOR ANT+
76	V	DRIVER DOOR ANT-
77	P	DRIVER DOOR ANT+
80	SB	IMMOBIL ANTENNA CONTROL
81	O	IMMOBIL ANTENNA SIGNAL

82	BR	IGN RELAY (F/B) CONT
83	P	KEYLESS ENTRY RECEIVER SIGNAL
87	R	COMBI SW INPUT 5
88	GR	COMBI SW INPUT 3
89	P	CAN-L
91	L	CAN-H
92	R	KEY SLOT ILL
93	P	ON IND
95	L	ACC RELAY CONT
96	Y	CVT SHIFT SELECTOR POWER SUPPLY
99	V	SHIFT P
100	P	PASSENGER DOOR REQUEST SW
101	W	DRIVER DOOR REQUEST SW
102	Y	BLOWER FAN MOTOR RELAY CONT
103	L	KEYLESS ENTRY RECEIVER POWER SUPPLY
107	O	COMBI SW INPUT 1
108	P	COMBI SW INPUT 4
109	SB	COMBI SW INPUT 2
110	G	HAZARD SW

BCM (BODY CONTROL MODULE)

< ECU DIAGNOSIS INFORMATION >

A
B
C
D
E
F
G
H
I
K
L
M
N
O
P

ADP

BCM (BODY CONTROL MODULE)

Connector No.	M123
Connector Name	BCM (BODY CONTROL MODULE)
Connector Type	TH40FG-1M

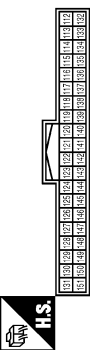

Terminal No.	Color of Wire	Signal Name [Specification]
112	R	RAIN SENSOR SERIAL LINK
113	O	OPTICAL SENSOR
116	GR	FUSE CHECK
118	L	STOP LAMP SW
119	W	DR DOOR UNLOCK SENSOR
121	Y	KEY SLOT SW
123	G	IGN P/B
124	R	PASSENGER DOOR SW
130	BR	REAR DEFOGGER SW
132	G	POWER WINDOW SW COMM
133	W	PUSH-BUTTON IGNITION SW ILL POWER
134	R	LOCK IND
137	P	RECEIVER / SENSOR GND
138	V	RECEIVER / SENSOR POWER SUPPLY
139	O	TIRE PRESS. RECEIVER SIGNAL
140	GR	SHIFT N/P
141	O	SECURITY INDICATOR OUTPUT
142	L	COMBI SW OUTPUT 5
143	W	COMBI SW OUTPUT 1
144	P	COMBI SW OUTPUT 2
145	V	COMBI SW OUTPUT 3
146	Y	COMBI SW OUTPUT 4
150	SB	DRIVER DOOR SW
151	G	REAR WINDOW DEFOGGER RELAY

JCMWN0020GB

INFOID:0000000006882473

Fail-safe

FAIL-SAFE CONTROL BY DTC

BCM performs fail-safe control when any DTC are detected.

BCM (BODY CONTROL MODULE)

< ECU DIAGNOSIS INFORMATION >

Display contents of CONSULT	Fail-safe	Cancellation
B2190: NATS ANTENNA AMP	Inhibit engine cranking	Erase DTC
B2191: DIFFERENCE OF KEY	Inhibit engine cranking	Erase DTC
B2192: ID DISCORD BCM-ECM	Inhibit engine cranking	Erase DTC
B2193: CHAIN OF BCM-ECM	Inhibit engine cranking	Erase DTC
B2195: ANTI SCANNING	Inhibit engine cranking	Ignition switch ON → OFF
B2560: STARTER CONT RELAY	Inhibit engine cranking	500 ms after the following CAN signal communication status becomes consistent <ul style="list-style-type: none"> • Starter control relay signal • Starter relay status signal
B2607: S/L RELAY	Inhibit engine cranking	500 ms after the following CAN signal communication status becomes consistent <ul style="list-style-type: none"> • Steering lock relay signal (Request signal) • Steering lock relay signal (Condition signal)
B2608: STARTER RELAY	Inhibit engine cranking	500 ms after the following signal communication status becomes consistent <ul style="list-style-type: none"> • Starter motor relay control signal • Starter relay status signal (CAN)
B260A: IGNITION RELAY	Inhibit engine cranking	500 ms after the following conditions are fulfilled <ul style="list-style-type: none"> • IGN relay (IPDM E/R) control signal: OFF (Battery voltage) • Ignition ON signal (CAN to IPDM E/R): OFF (Request signal) • Ignition ON signal (CAN from IPDM E/R): OFF (Condition signal)
B260F: ENG STATE SIG LOST	Maintains the power supply position attained at the time of DTC detection	When any of the following conditions are fulfilled <ul style="list-style-type: none"> • Power position changes to ACC • Receives engine status signal (CAN)
B2617: STARTER RELAY CIRC	Inhibit engine cranking	1 second after the starter motor relay control inside BCM becomes normal
B2618: BCM	Inhibit engine cranking	1 second after the ignition relay (IPDM E/R) control inside BCM becomes normal
B261E: VEHICLE TYPE	Inhibit engine cranking	BCM initialization

HIGH FLASHER OPERATION

BCM detects the turn signal lamp circuit status by the current value.

BCM increases the turn signal lamp blinking speed if the bulb or harness open is detected with the turn signal lamp operating.

NOTE:

The blinking speed is normal while activating the hazard warning lamp.

FAIL-SAFE CONTROL BY RAIN SENSOR MALFUNCTION

- BCM judges the rain sensor serial link error by the rain sensor serial link condition and detects the rain sensor malfunction by rain sensor malfunction signal.
- When BCM detects the rain sensor serial link error or the rain sensor malfunction while front wiper AUTO operation, BCM operates a fail-safe control.

NOTE:

If rain sensor malfunction is detected when ignition switch is turned OFF ⇒ ON and front wiper switch is INT/AUTO position, BCM operates a fail-safe control.

REAR WIPER MOTOR PROTECTION

BCM detects the rear wiper stopping position according to the rear wiper stop position signal.

When the rear wiper stop position signal does not change for more than 5 seconds while driving the rear wiper, BCM stops power supply to protect the rear wiper motor.

Condition of cancellation

1. More than 1 minute is passed after the rear wiper stop.
2. Turn rear wiper switch OFF.
3. Operate the rear wiper switch or rear washer switch.

BCM (BODY CONTROL MODULE)

< ECU DIAGNOSIS INFORMATION >

DTC Inspection Priority Chart

INFOID:000000006882474

If some DTCs are displayed at the same time, perform inspections one by one based on the following priority chart.

Priority	DTC
1	B2562: LOW VOLTAGE
2	<ul style="list-style-type: none"> • U1000: CAN COMM • U1010: CONTROL UNIT(CAN)
3	<ul style="list-style-type: none"> • B2190: NATS ANTENNA AMP • B2191: DIFFERENCE OF KEY • B2192: ID DISCORD BCM-ECM • B2193: CHAIN OF BCM-ECM • B2195: ANTI SCANNING
4	<ul style="list-style-type: none"> • B2553: IGNITION RELAY • B2555: STOP LAMP • B2556: PUSH-BTN IGN SW • B2557: VEHICLE SPEED • B2560: STARTER CONT RELAY • B2601: SHIFT POSITION • B2602: SHIFT POSITION • B2603: SHIFT POSI STATUS • B2604: PNP SW • B2605: PNP SW • B2608: STARTER RELAY • B260A: IGNITION RELAY • B260F: ENG STATE SIG LOST • B2614: ACC RELAY CIRC • B2615: BLOWER RELAY CIRC • B2616: IGN RELAY CIRC • B2617: STARTER RELAY CIRC • B2618: BCM • B261A: PUSH-BTN IGN SW • B261E: VEHICLE TYPE • B26EA: KEY REGISTRATION • C1729: VHCL SPEED SIG ERR • U0415: VEHICLE SPEED SIG
5	<ul style="list-style-type: none"> • C1704: LOW PRESSURE FL • C1705: LOW PRESSURE FR • C1706: LOW PRESSURE RR • C1707: LOW PRESSURE RL • C1708: [NO DATA] FL • C1709: [NO DATA] FR • C1710: [NO DATA] RR • C1711: [NO DATA] RL • C1716: [PRESSDATA ERR] FL • C1717: [PRESSDATA ERR] FR • C1718: [PRESSDATA ERR] RR • C1719: [PRESSDATA ERR] RL • C1734: CONTROL UNIT
6	<ul style="list-style-type: none"> • B2622: INSIDE ANTENNA • B2623: INSIDE ANTENNA

DTC Index

INFOID:000000006882475

NOTE:

The details of time display are as follows.

- CRNT: A malfunction is detected now.
- PAST: A malfunction was detected in the past.

IGN counter is displayed on Freeze Frame Data. For details of Freeze Frame Data, refer to [BCS-18. "COMMON ITEM : CONSULT-III Function \(BCM - COMMON ITEM\)".](#)

BCM (BODY CONTROL MODULE)

< ECU DIAGNOSIS INFORMATION >

CONSULT display	Fail-safe	Freeze Frame Data •Vehicle Speed •Odo/Trip Meter •Vehicle Condition	Intelligent Key warning lamp ON	Tire pressure monitor warning lamp ON	Reference page
No DTC is detected. further testing may be required.	—	—	—	—	—
U1000: CAN COMM	—	—	—	—	BCS-38
U1010: CONTROL UNIT(CAN)	—	—	—	—	BCS-39
U0415: VEHICLE SPEED SIG	—	—	—	—	BCS-40
B2190: NATS ANTENNA AMP	×	—	—	—	SEC-42
B2191: DIFFERENCE OF KEY	×	—	—	—	SEC-45
B2192: ID DISCORD BCM-ECM	×	—	—	—	SEC-46
B2193: CHAIN OF BCM-ECM	×	—	—	—	SEC-48
B2195: ANTI SCANNING	×	—	—	—	SEC-49
B2553: IGNITION RELAY	—	×	—	—	PCS-48
B2555: STOP LAMP	—	×	—	—	SEC-50
B2556: PUSH-BTN IGN SW	—	×	×	—	SEC-52
B2557: VEHICLE SPEED	×	×	×	—	SEC-54
B2560: STARTER CONT RELAY	×	×	×	—	SEC-55
B2562: LOW VOLTAGE	—	×	—	—	BCS-41
B2601: SHIFT POSITION	×	×	×	—	SEC-56
B2602: SHIFT POSITION	×	×	×	—	SEC-59
B2603: SHIFT POSI STATUS	×	×	×	—	SEC-61
B2604: PNP SW	×	×	×	—	SEC-64
B2605: PNP SW	×	×	×	—	SEC-66
B2608: STARTER RELAY	×	×	×	—	SEC-68
B260A: IGNITION RELAY	×	×	×	—	PCS-50
B260F: ENG STATE SIG LOST	×	×	×	—	SEC-70
B2614: ACC RELAY CIRC	—	×	×	—	PCS-52
B2615: BLOWER RELAY CIRC	—	×	×	—	PCS-55
B2616: IGN RELAY CIRC	—	×	×	—	PCS-58
B2617: STARTER RELAY CIRC	×	×	×	—	SEC-72
B2618: BCM	×	×	×	—	PCS-61
B261A: PUSH-BTN IGN SW	—	×	×	—	SEC-75
B261E: VEHICLE TYPE	×	×	× (Turn ON for 15 seconds)	—	SEC-78
B2622: INSIDE ANTENNA	—	×	—	—	DLK-91
B2623: INSIDE ANTENNA	—	×	—	—	DLK-93
B26EA: KEY REGISTRATION	—	×	× (Turn ON for 15 seconds)	—	SEC-71
C1704: LOW PRESSURE FL	—	—	—	×	WT-23
C1705: LOW PRESSURE FR	—	—	—	×	
C1706: LOW PRESSURE RR	—	—	—	×	
C1707: LOW PRESSURE RL	—	—	—	×	

BCM (BODY CONTROL MODULE)

< ECU DIAGNOSIS INFORMATION >

CONSULT display	Fail-safe	Freeze Frame Data •Vehicle Speed •Odo/Trip Meter •Vehicle Condition	Intelligent Key warning lamp ON	Tire pressure monitor warning lamp ON	Reference page
C1708: [NO DATA] FL	—	—	—	×	WT-25
C1709: [NO DATA] FR	—	—	—	×	
C1710: [NO DATA] RR	—	—	—	×	
C1711: [NO DATA] RL	—	—	—	×	
C1716: [PRESSDATA ERR] FL	—	—	—	×	WT-28
C1717: [PRESSDATA ERR] FR	—	—	—	×	
C1718: [PRESSDATA ERR] RR	—	—	—	×	
C1719: [PRESSDATA ERR] RL	—	—	—	×	
C1729: VHCL SPEED SIG ERR	—	—	—	×	WT-29
C1734: CONTROL UNIT	—	—	—	×	WT-30

A
B
C
D
E
F
G
H
I
K
L
M
N
O
P

ADP

ADP SYSTEM SYMPTOMS

< SYMPTOM DIAGNOSIS >

SYMPTOM DIAGNOSIS

ADP SYSTEM SYMPTOMS

Symptom Table

INFOID:000000006258132

The diagnostics item numbers show the sequence for inspection. Inspection in order from item 1.

Order	Function	Operation procedure	Symptom	Diagnostic item	Reference page
1	Memory function	Perform memory storage (Refer to ADP-10.) and memory operation (Refer to ADP-22.).	All parts do not operate in memory function.	—	ADP-187
			Memory indicator 1 or 2 does not operate.	—	ADP-188
2	Manual function	Perform manual function (Refer to ADP-17.).	All components of power seat do not operate.	—	ADP-189
			All components of tilt&telescopic do not operate.	—	ADP-197
3	Manual function and memory function	Perform manual function (Refer to ADP-17.) and memory function (Refer to ADP-22.).	Manual function or memory function does not operate. (for specific part)	Sliding	ADP-190
				Reclining	ADP-190
				Lifting (front)	ADP-191
				Lifting (rear)	ADP-192
				Steering tilt	ADP-192
				Steering telescopic	ADP-193
4	Entry/exit assist function	Perform entry/exit assist function. Exit assist function: Refer to ADP-27 Entry assist function: Refer to ADP-32	Entry/exit assist function does not operate.	—	ADP-195
5	Intelligent Key inter lock function	Perform Intelligent Key inter lock function (Refer to ADP-37.).	Intelligent Key inter lock function does not operate.	—	ADP-196

ALL PARTS DO NOT OPERATE IN MEMORY FUNCTION

< SYMPTOM DIAGNOSIS >

ALL PARTS DO NOT OPERATE IN MEMORY FUNCTION

Diagnosis Procedure

INFOID:000000006258133

1. CHECK MEMORY FUNCTION

Check memory function.

Refer to [ADP-22, "MEMORY FUNCTION : System Description"](#).

Is the inspection result normal?

- YES >> Memory function is normal.
- NO >> GO TO 2.

2. CHECK SEAT MEMORY SWITCH

Check seat memory switch.

Refer to [ADP-69, "Component Function Check"](#).

Is the inspection result normal?

- YES >> GO TO 3.
- NO >> Repair or replace the malfunction parts.

3. CHECK DRIVER SEAT CONTROL UNIT POWER SUPPLY AND GROUND CIRCUIT

Check driver seat control unit power supply and ground circuit.

Refer to [ADP-55, "DRIVER SEAT CONTROL UNIT : Diagnosis Procedure"](#).

Is the inspection result normal?

- YES >> GO TO 4.
- NO >> Repair or replace the malfunction parts.

4. CHECK AUTOMATIC DRIVE POSITIONER CONTROL UNIT POWER SUPPLY AND GROUND CIRCUIT

Check automatic drive positioner control unit power supply and ground circuit.

Refer to [ADP-55, "AUTOMATIC DRIVE POSITIONER CONTROL UNIT : Diagnosis Procedure"](#).

Is the inspection result normal?

- YES >> GO TO 5.
- NO >> Repair or replace the malfunction parts.

5. PERFORM INITIALIZATION AND MEMORY STORING PROCEDURE

1. Perform initialization procedure.

Refer to [ADP-9, "SYSTEM INITIALIZATION : Special Repair Requirement"](#).

2. Perform memory storing procedure.

Refer to [ADP-10, "MEMORY STORING : Special Repair Requirement"](#).

3. Check memory function.

Refer to [ADP-22, "MEMORY FUNCTION : System Description"](#).

Is the inspection result normal?

- YES >> Memory function is normal.
- NO >> GO TO 6.

6. CONFIRM THE OPERATION

Confirm the operation again.

Is the result normal?

- YES >> Check intermittent incident. Refer to [GI-44, "Intermittent Incident"](#).
- NO >> GO TO 1.

A
B
C
D
E
F
G
H
I
K
L
M
N
O
P

ADP

MEMORY INDICATE DOES NOT OPERATE

< SYMPTOM DIAGNOSIS >

MEMORY INDICATE DOES NOT OPERATE

Diagnosis Procedure

INFOID:000000006258134

1.CHECK MEMORY INDICATOR

Check memory indicator.

Refer to [ADP-116, "Component Function Check"](#).

Is the inspection result normal?

YES >> GO TO 2.

NO >> Repair or replace the malfunction parts.

2.CONFIRM THE OPERATION

Confirm the operation again.

Is the result normal?

YES >> Check intermittent incident. Refer to [GI-44, "Intermittent Incident"](#).

NO >> GO TO 1.

ALL COMPONENTS OF POWER SEAT DO NOT OPERATE

< SYMPTOM DIAGNOSIS >

ALL COMPONENTS OF POWER SEAT DO NOT OPERATE

Diagnosis Procedure

INFOID:000000006258135

1. CHECK POWER SEAT SWITCH GROUND CIRCUIT

Check power seat switch ground circuit.
Refer to [ADP-77, "Diagnosis Procedure"](#).

Is the inspection result normal?

- YES >> GO TO 2.
- NO >> Repair or replace harness or connector.

2. CONFIRM THE OPERATION

Confirm the operation again.

Is the result normal?

- YES >> Check intermittent incident. Refer to [GI-44, "Intermittent Incident"](#).
- NO >> GO TO 1.

A
B
C
D
E
F
G
H
I
K
L
M
N
O
P

ADP

MANUAL FUNCTION OR MEMORY FUNCTION DOES NOT OPERATE

< SYMPTOM DIAGNOSIS >

MANUAL FUNCTION OR MEMORY FUNCTION DOES NOT OPERATE SEAT SLIDING

SEAT SLIDING : Diagnosis Procedure

INFOID:000000006258136

1.CHECK SLIDING MECHANISM

Check for the following.

- Mechanism deformation or pinched foreign materials.
- Interference with other parts because of poor installation.

Is the inspection result normal?

YES >> GO TO 2.

NO >> Repair or replace the malfunction parts.

2.CHECK SLIDING SWITCH

Check sliding switch.

Refer to [ADP-57, "Component Function Check"](#).

Is the inspection result normal?

YES >> GO TO 3.

NO >> Repair or replace the malfunction parts.

3.CHECK SLIDING MOTOR

Check sliding motor.

Refer to [ADP-102, "Component Function Check"](#).

Is the inspection result normal?

YES >> GO TO 4.

NO >> Repair or replace the malfunction parts.

4.CHECK SLIDING SENSOR

Check sliding sensor.

Refer to [ADP-81, "Component Function Check"](#).

Is the inspection result normal?

YES >> GO TO 5.

NO >> Repair or replace the malfunction parts.

5.CONFIRM THE OPERATION

Check the operation again.

Is the result normal?

YES >> Check intermittent incident. Refer to [GI-44, "Intermittent Incident"](#).

NO >> GO TO 1.

SEAT RECLINING

SEAT RECLINING : Diagnosis Procedure

INFOID:000000006258137

1.CHECK RECLINING MECHANISM

Check for the following.

- Mechanism deformation or pinched foreign materials.
- Interference with other parts because of poor installation.

Is the inspection result normal?

YES >> GO TO 2.

NO >> Repair or replace the malfunction parts.

2.CHECK RECLINING SWITCH

Check reclining switch.

Refer to [ADP-59, "Component Function Check"](#).

Is the inspection result normal?

MANUAL FUNCTION OR MEMORY FUNCTION DOES NOT OPERATE

< SYMPTOM DIAGNOSIS >

- YES >> GO TO 3.
NO >> Repair or replace the malfunction parts.

3.CHECK RECLINING MOTOR

Check reclining motor.
Refer to [ADP-104. "Component Function Check"](#).

Is the inspection result normal?

- YES >> GO TO 4.
NO >> Repair or replace the malfunction parts.

4.CHECK RECLINING SENSOR

Check reclining sensor.
Refer to [ADP-84. "Component Function Check"](#).

Is the inspection result normal?

- YES >> GO TO 5.
NO >> Repair or replace the malfunction parts.

5.CONFIRM THE OPERATION

Check the operation again.

Is the result normal?

- YES >> Check intermittent incident. Refer to [GI-44. "Intermittent Incident"](#).
NO >> GO TO 1.

SEAT LIFTING (FRONT)

SEAT LIFTING (FRONT) : Diagnosis Procedure

INFOID:000000006258138

1.CHECK LIFTING (FRONT) MECHANISM

Check for the following.

- Mechanism deformation or pinched foreign materials.
- Interference with other parts because of poor installation.

Is the inspection result normal?

- YES >> GO TO 2.
NO >> Repair or replace the malfunction parts.

2.CHECK LIFTING SWITCH (FRONT)

Check lifting switch (front).
Refer to [ADP-61. "Component Function Check"](#).

Is the inspection result normal?

- YES >> GO TO 3.
NO >> Repair or replace the malfunction parts.

3.CHECK LIFTING MOTOR (FRONT)

Check lifting motor (front).
Refer to [ADP-106. "Component Function Check"](#).

Is the inspection result normal?

- YES >> GO TO 4.
NO >> Repair or replace the malfunction parts.

4.CHECK LIFTING SENSOR (FRONT)

Check lifting sensor (front).
Refer to [ADP-87. "Component Function Check"](#).

Is the inspection result normal?

- YES >> GO TO 5.
NO >> Repair or replace the malfunction parts.

5.CONFIRM THE OPERATION

Check the operation again.

A
B
C
D
E
F
G
H
I
K
L
M
N
O
P

ADP

MANUAL FUNCTION OR MEMORY FUNCTION DOES NOT OPERATE

< SYMPTOM DIAGNOSIS >

Is the result normal?

- YES >> Check intermittent incident. Refer to [GI-44, "Intermittent Incident"](#).
NO >> GO TO 1.

SEAT LIFTING (REAR)

SEAT LIFTING (REAR) : Diagnosis Procedure

INFOID:000000006258139

1.CHECK LIFTING (REAR) MECHANISM

Check for the following.

- Mechanism deformation or pinched foreign materials.
- Interference with other parts because of poor installation.

Is the inspection result normal?

- YES >> GO TO 2.
NO >> Repair or replace the malfunction parts.

2.CHECK LIFTING SWITCH (REAR)

Check lifting switch (rear).

Refer to [ADP-63, "Component Function Check"](#).

Is the inspection result normal?

- YES >> GO TO 3.
NO >> Repair or replace the malfunction parts.

3.CHECK LIFTING MOTOR (REAR)

Check lifting motor (rear).

Refer to [ADP-108, "Component Function Check"](#).

Is the inspection result normal?

- YES >> GO TO 4.
NO >> Repair or replace the malfunction parts.

4.CHECK LIFTING SENSOR (REAR)

Check lifting sensor (rear).

Refer to [ADP-90, "Component Function Check"](#).

Is the inspection result normal?

- YES >> GO TO 5.
NO >> Repair or replace the malfunction parts.

5.CONFIRM THE OPERATION

Check the operation again.

Is the result normal?

- YES >> Check intermittent incident. Refer to [GI-44, "Intermittent Incident"](#).
NO >> GO TO 1.

STEERING TILT

STEERING TILT : Diagnosis Procedure

INFOID:000000006258140

1.CHECK STEERING TILT MECHANISM

Check for the following.

- Mechanism deformation or pinched foreign materials.
- Interference with other parts because of poor installation.

Is the inspection result normal?

- YES >> GO TO 2.
NO >> Repair or replace the malfunction parts.

2.CHECK TILT SWITCH

Check tilt switch.

Refer to [ADP-65, "Component Function Check"](#).

MANUAL FUNCTION OR MEMORY FUNCTION DOES NOT OPERATE

< SYMPTOM DIAGNOSIS >

Is the inspection result normal?

- YES >> GO TO 3.
NO >> Repair or replace the malfunction parts.

3.CHECK TILT MOTOR

Check tilt motor.

Refer to [ADP-110, "Component Function Check"](#).

Is the inspection result normal?

- YES >> GO TO 4.
NO >> Repair or replace the malfunction parts.

4.CHECK TILT SENSOR

Check steering tilt sensor.

Refer to [ADP-93, "Component Function Check"](#).

Is the inspection result normal?

- YES >> GO TO 5.
NO >> Repair or replace the malfunction parts.

5.CONFIRM THE OPERATION

Check the operation again.

Is the result normal?

- YES >> Check intermittent incident. Refer to [GI-44, "Intermittent Incident"](#).
NO >> GO TO 1.

STEERING TELESCOPIC

STEERING TELESCOPIC : Diagnosis Procedure

INFOID:000000006258141

1.CHECK STEERING TELESCOPIC MECHANISM

Check for the following.

- Mechanism deformation or pinched foreign materials.
- Interference with other parts because of poor installation.

Is the inspection result normal?

- YES >> GO TO 2.
NO >> Repair or replace the malfunction parts.

2.CHECK TELESCOPIC SWITCH

Check telescopic switch.

Refer to [ADP-67, "Component Function Check"](#).

Is the inspection result normal?

- YES >> GO TO 3.
NO >> Repair or replace the malfunction parts.

3.CHECK TELESCOPIC MOTOR

Check telescopic motor.

Refer to [ADP-112, "Component Function Check"](#).

Is the inspection result normal?

- YES >> GO TO 4.
NO >> Repair or replace the malfunction parts.

4.CHECK TELESCOPIC SENSOR

Check steering telescopic sensor.

Refer to [ADP-95, "Component Function Check"](#).

Is the inspection result normal?

- YES >> GO TO 5.
NO >> Repair or replace the malfunction parts.

5.CONFIRM THE OPERATION

A
B
C
D
E
F
G
H
I
K
L
M
N
O
P

ADP

MANUAL FUNCTION OR MEMORY FUNCTION DOES NOT OPERATE

< SYMPTOM DIAGNOSIS >

Check the operation again.

Is the result normal?

YES >> Check intermittent incident. Refer to [GI-44, "Intermittent Incident"](#).

NO >> GO TO 1.

DOOR MIRROR

DOOR MIRROR : Diagnosis Procedure

INFOID:000000006258142

1.CHECK DOOR MIRROR MECHANISM

Check for the following.

- Mechanism deformation or pinched foreign materials.
- Interference with other parts because of poor installation.

Is the inspection result normal?

YES >> GO TO 2.

NO >> Repair or replace the malfunction parts.

2.CHECK MIRROR SWITCH

Check mirror switch.

Refer to [ADP-74, "MIRROR SWITCH : Component Function Check"](#).

Is the inspection result normal?

YES >> GO TO 3.

NO >> Repair or replace the malfunction parts.

3.CHECK MIRROR MOTOR

Check mirror motor.

Refer to [ADP-114, "Component Function Check"](#).

Is the inspection result normal?

YES >> GO TO 4.

NO >> Repair or replace the malfunction parts.

4.CHECK MIRROR SENSOR

Check mirror sensor.

Refer to [ADP-98, "DRIVER SIDE : Component Function Check"](#). (Driver side)

Refer to [ADP-99, "PASSENGER SIDE : Component Function Check"](#). (Passenger side)

Is the inspection result normal?

YES >> GO TO 5.

NO >> Repair or replace the malfunction parts.

5.CONFIRM THE OPERATION

Check the operation again.

Is the result normal?

YES >> Check intermittent incident. Refer to [GI-44, "Intermittent Incident"](#).

NO >> GO TO 1.

ENTRY/EXIT ASSIST FUNCTION DOES NOT OPERATE

< SYMPTOM DIAGNOSIS >

ENTRY/EXIT ASSIST FUNCTION DOES NOT OPERATE

Diagnosis Procedure

INFOID:000000006258143

1. CHECK SYSTEM SETTING

1. Check system setting.
Refer to [ADP-11, "SYSTEM SETTING : Special Repair Requirement"](#).

2. Check the operation.

Is the inspection result normal?

YES >> Entry/Exit function is OK.

NO >> GO TO 2.

2. PERFORM SYSTEM INITIALIZATION

1. Perform system initialization.
Refer to [ADP-9, "SYSTEM INITIALIZATION : Special Repair Requirement"](#).

2. Check the operation.

Is the inspection result normal?

YES >> Entry/Exit function is OK.

NO >> GO TO 3.

3. CHECK FRONT DOOR SWITCH (DRIVER SIDE)

Check front door switch (driver side).

Refer to [DLK-97, "WITH AUTOMATIC BACK DOOR : Component Function Check"](#).

Is the inspection result normal?

YES >> GO TO 4.

NO >> Repair or replace the malfunction parts.

4. CONFIRM THE OPERATION

Confirm the operation again.

Is the result normal?

YES >> Check intermittent incident. Refer to [GI-44, "Intermittent Incident"](#).

NO >> GO TO 1.

A
B
C
D
E
F
G
H
I
K
L
M
N
O
P

ADP

INTELLIGENT KEY INTERLOCK FUNCTION DOES NOT OPERATE

< SYMPTOM DIAGNOSIS >

INTELLIGENT KEY INTERLOCK FUNCTION DOES NOT OPERATE

Diagnosis Procedure

INFOID:000000006258144

1. CHECK DOOR LOCK FUNCTION

Check door lock function.

Refer to [DLK-10, "Work Flow"](#).

Is the inspection result normal?

YES >> GO TO 2.

NO >> Repair or replace the malfunction parts.

2. PERFORM MEMORY STORING PROCEDURE

1. Perform memory storing procedure.

Refer to [ADP-10, "MEMORY STORING : Special Repair Requirement"](#).

2. Check Intelligent Key interlock function.

Refer to [ADP-37, "INTELLIGENT KEY INTERLOCK FUNCTION : System Description"](#).

Is the inspection result normal?

YES >> Intelligent Key inter lock function is normal.

NO >> Replace driver seat control unit. Refer to [ADP-201, "Removal and Installation"](#).

ALL COMPONENTS OF TILT & TELESCOPIC SWITCH DO NOT OPERATE

< SYMPTOM DIAGNOSIS >

ALL COMPONENTS OF TILT & TELESCOPIC SWITCH DO NOT OPERATE

Diagnosis Procedure

INFOID:000000006258145

1. CHECK TILT & TELESCOPIC SWITCH GROUND CIRCUIT

Check tilt & telescopic switch ground circuit.
Refer to [ADP-78, "Diagnosis Procedure"](#).

Is the inspection result normal?

- YES >> GO TO 2.
- NO >> Repair or replace harness or connector.

2. CONFIRM THE OPERATION

Confirm the operation again.

Is the result normal?

- YES >> Check intermittent incident. Refer to [GI-44, "Intermittent Incident"](#).
- NO >> GO TO 1.

A
B
C
D
E
F
G
H
I
K
L
M
N
O
P

ADP

NORMAL OPERATING CONDITION

< SYMPTOM DIAGNOSIS >

NORMAL OPERATING CONDITION

Description

INFOID:000000006258146

The following symptoms are normal operations, and they do not indicate a malfunction.

Symptom	Cause	Action to take	Reference page
Entry/exit assist function and seat synchronization do not operate.	No initialization has been performed.	Perform initialization.	ADP-9
	Entry/exit assist function is disabled. NOTE: The entry/exit assist function and seat synchronization function are disabled before delivery (initial setting).	Change the settings.	ADP-11
Entry assist function does not operate.	Manual operation with power seat switch was performed after exit assist function execution.	Perform the memory function.	ADP-32
Lumbar support does not perform memory operation.	The lumbar support system are controlled independently with no link to the automatic drive positioner system.	—	Lumbar support system: SE-8
Memory function, entry/exit assist function, or Intelligent Key interlock function does not operate.	The operating conditions are not fulfilled.	Fulfill the operation conditions.	Memory function: ADP-22
			Exit assist function: ADP-27
			Entry assist function: ADP-32
			Intelligent Key interlock function: ADP-37

PRECAUTIONS

< PRECAUTION >

PRECAUTION

PRECAUTIONS FOR USA AND CANADA

FOR USA AND CANADA : Precaution for Supplemental Restraint System (SRS) "AIR BAG" and "SEAT BELT PRE-TENSIONER"

INFOID:000000006258147

The Supplemental Restraint System such as "AIR BAG" and "SEAT BELT PRE-TENSIONER", used along with a front seat belt, helps to reduce the risk or severity of injury to the driver and front passenger for certain types of collision. This system includes seat belt switch inputs and dual stage front air bag modules. The SRS system uses the seat belt switches to determine the front air bag deployment, and may only deploy one front air bag, depending on the severity of a collision and whether the front occupants are belted or unbelted. Information necessary to service the system safely is included in the "SRS AIR BAG" and "SEAT BELT" of this Service Manual.

WARNING:

Always observe the following items for preventing accidental activation.

- To avoid rendering the SRS inoperative, which could increase the risk of personal injury or death in the event of a collision that would result in air bag inflation, all maintenance must be performed by an authorized NISSAN/INFINITI dealer.
- Improper maintenance, including incorrect removal and installation of the SRS, can lead to personal injury caused by unintentional activation of the system. For removal of Spiral Cable and Air Bag Module, see "SRS AIR BAG".
- Never use electrical test equipment on any circuit related to the SRS unless instructed to in this Service Manual. SRS wiring harnesses can be identified by yellow and/or orange harnesses or harness connectors.

PRECAUTIONS WHEN USING POWER TOOLS (AIR OR ELECTRIC) AND HAMMERS

WARNING:

Always observe the following items for preventing accidental activation.

- When working near the Air Bag Diagnosis Sensor Unit or other Air Bag System sensors with the ignition ON or engine running, never use air or electric power tools or strike near the sensor(s) with a hammer. Heavy vibration could activate the sensor(s) and deploy the air bag(s), possibly causing serious injury.
- When using air or electric power tools or hammers, always switch the ignition OFF, disconnect the battery, and wait at least 3 minutes before performing any service.

FOR MEXICO

FOR MEXICO : Precaution for Supplemental Restraint System (SRS) "AIR BAG" and "SEAT BELT PRE-TENSIONER"

INFOID:000000006258148

The Supplemental Restraint System such as "AIR BAG" and "SEAT BELT PRE-TENSIONER", used along with a front seat belt, helps to reduce the risk or severity of injury to the driver and front passenger for certain types of collision. Information necessary to service the system safely is included in the "SRS AIR BAG" and "SEAT BELT" of this Service Manual.

WARNING:

Always observe the following items for preventing accidental activation.

- To avoid rendering the SRS inoperative, which could increase the risk of personal injury or death in the event of a collision that would result in air bag inflation, all maintenance must be performed by an authorized NISSAN/INFINITI dealer.
- Improper maintenance, including incorrect removal and installation of the SRS, can lead to personal injury caused by unintentional activation of the system. For removal of Spiral Cable and Air Bag Module, see "SRS AIR BAG".
- Never use electrical test equipment on any circuit related to the SRS unless instructed to in this Service Manual. SRS wiring harnesses can be identified by yellow and/or orange harnesses or harness connectors.

PRECAUTIONS WHEN USING POWER TOOLS (AIR OR ELECTRIC) AND HAMMERS

WARNING:

A

B

C

D

E

F

G

H

I

ADP

K

L

M

N

O

P

PRECAUTIONS

< PRECAUTION >

Always observe the following items for preventing accidental activation.

- When working near the Air Bag Diagnosis Sensor Unit or other Air Bag System sensors with the ignition ON or engine running, never use air or electric power tools or strike near the sensor(s) with a hammer. Heavy vibration could activate the sensor(s) and deploy the air bag(s), possibly causing serious injury.
- When using air or electric power tools or hammers, always switch the ignition OFF, disconnect the battery, and wait at least 3 minutes before performing any service.

DRIVER SEAT CONTROL UNIT

< REMOVAL AND INSTALLATION >

REMOVAL AND INSTALLATION

DRIVER SEAT CONTROL UNIT

Exploded View

INFOID:000000006258149

Refer to [SE-90, "Exploded View"](#).

Removal and Installation

INFOID:000000006258150

REMOVAL

CAUTION:

When removing and installing, use shop cloths to protect parts from damage.

1. Remove the driver seat (1). Refer to [SE-97, "Removal and Installation"](#).
2. Remove the mounting nut (A).
3. Remove driver seat control unit (2).

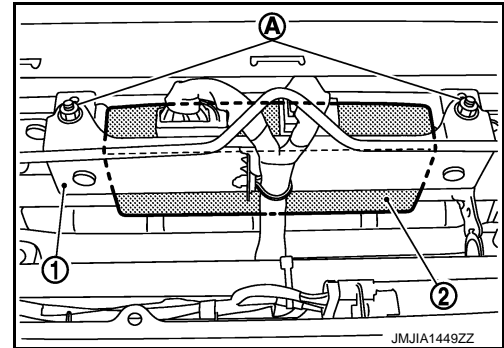

INSTALLATION

Install in the reverse order of removal.

CAUTION:

Be sure to clump the harness to the right place.

NOTE:

After installing the driver seat, perform additional service when replacing control unit. Refer to [ADP-8, "ADDITIONAL SERVICE WHEN REPLACING CONTROL UNIT : Description"](#).

A
B
C
D
E
F
G
H
I
K
L
M
N
O
P

ADP

AUTOMATIC DRIVE POSITIONER CONTROL UNIT

< REMOVAL AND INSTALLATION >

AUTOMATIC DRIVE POSITIONER CONTROL UNIT

Exploded View

INFOID:000000006258151

Refer to [IP-12. "Exploded View"](#).

Removal and Installation

INFOID:000000006258152

REMOVAL

CAUTION:

When removing and installing, use shop cloths to protect parts from damage.

1. Remove the instrument driver lower panel. Refer to [IP-13. "Removal and Installation"](#).
2. Remove the screws (A).
3. Remove automatic drive positioner control unit (1).

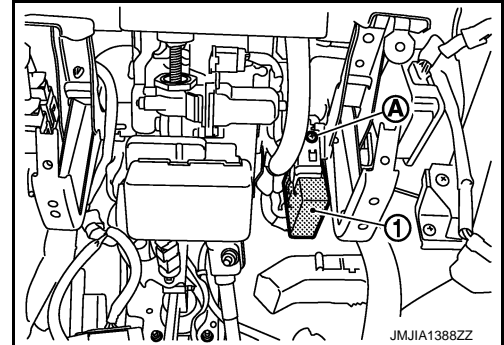

INSTALLATION

Install in the reverse order of removal.

CAUTION:

Be sure to clump the harness to the right place.

NOTE:

After installing the driver seat, perform additional service when removing battery negative terminal. Refer to [ADP-8. "ADDITIONAL SERVICE WHEN REMOVING BATTERY NEGATIVE TERMINAL : Description"](#).

SEAT MEMORY SWITCH

< REMOVAL AND INSTALLATION >

SEAT MEMORY SWITCH

Exploded View

INFOID:000000006258153

Refer to [INT-12. "FRONT DOOR FINISHER : Exploded View"](#).

Removal and Installation

INFOID:000000006258154

REMOVAL

CAUTION:

When removing and installing, use shop cloths to protect parts from damage.

1. Remove the seat memory finisher (1). Refer to [INT-12. "FRONT DOOR FINISHER : Removal and Installation"](#).
2. Press pawls and remove seat memory switch (2) from seat memory finisher (1).

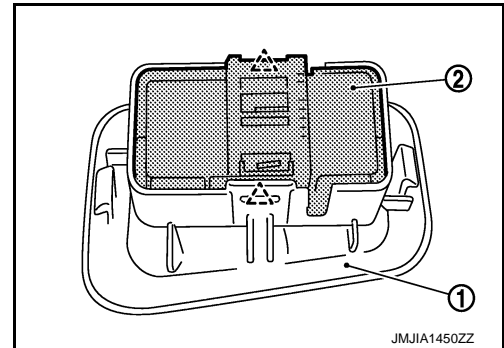

INSTALLATION

Install in the reverse order of removal.

CAUTION:

Be sure to clump the harness to the right place.

NOTE:

After installing the driver seat, perform additional service when removing battery negative terminal. Refer to [ADP-8. "ADDITIONAL SERVICE WHEN REMOVING BATTERY NEGATIVE TERMINAL : Description"](#).

A
B
C
D
E
F
G
H
I
K
L
M
N
O
P

ADP

POWER SEAT SWITCH

< REMOVAL AND INSTALLATION >

POWER SEAT SWITCH

Exploded View

INFOID:000000006258155

Refer to [SE-90. "Exploded View"](#).

Removal and Installation

INFOID:000000006258156

REMOVAL

CAUTION:

When removing and installing, use shop cloths to protect parts from damage.

1. Remove the seat cushion outer finisher (1). Refer to [SE-97. "Removal and Installation"](#).
2. Remove the screws (A).
3. Remove the power seat switch (2) from the seat cushion outer finisher (1).

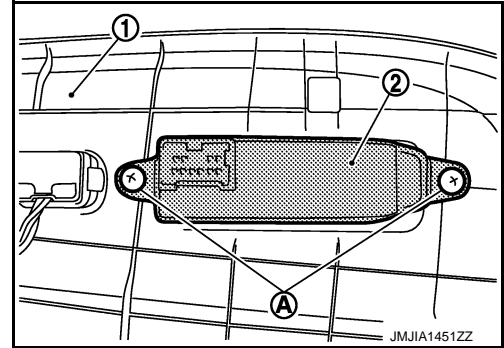

INSTALLATION

Install in the reverse order of removal.

CAUTION:

Be sure to clamp the harness to the right place.

NOTE:

After installing the driver seat, perform additional service when removing battery negative terminal. Refer to [ADP-8. "ADDITIONAL SERVICE WHEN REMOVING BATTERY NEGATIVE TERMINAL : Description"](#).

TILT&TELESCOPIC SWITCH

< REMOVAL AND INSTALLATION >

TILT&TELESCOPIC SWITCH

Exploded View

INFOID:000000006258157

Refer to [IP-12. "Exploded View"](#).

Removal and Installation

INFOID:000000006258158

REMOVAL

CAUTION:

When removing and installing, use shop cloths to protect parts from damage.

1. Remove the steering column mask (1). Refer to [IP-13. "Removal and Installation"](#).
2. Press pawls and remove tilt & telescopic switch (2) from the steering column mask (1).

 : Pawl

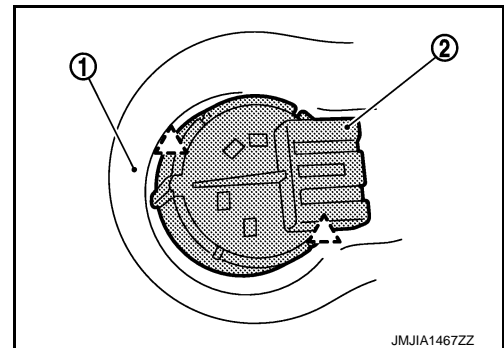

INSTALLATION

Install in the reverse order of removal.

CAUTION:

Be sure to clump the harness to the right place.

NOTE:

After installing the driver seat, perform additional service when removing battery negative terminal. Refer to [ADP-8. "ADDITIONAL SERVICE WHEN REMOVING BATTERY NEGATIVE TERMINAL : Description"](#).

A
B
C
D
E
F
G
H
I
K
L
M
N
O
P

ADP