

SECTION **VTL**
VENTILATION SYSTEM

A
B
C
D
E
F
G
H
VTL
J
K
L
M
N
O
P

CONTENTS

WITHOUT 7 INCH DISPLAY	PERIODIC MAINTENANCE	21
SYSTEM DESCRIPTION	IN-CABIN MICROFILTER	21
5	Exploded View	21
SWITCHES AND THEIR CONTROL FUNCTION	Removal and Installation	21
5	Replacement	21
System Description	REMOVAL AND INSTALLATION	22
5	A/C CONTROL	22
AIR DISTRIBUTION	Exploded View	22
7	Removal and Installation	22
System Description	A/C DISPLAY	24
7	Exploded View	24
PRECAUTION	Removal and Installation	24
8	A/C AUTO AMP.	25
PRECAUTIONS	Exploded View	25
8	Removal and Installation	25
FOR USA AND CANADA	AMBIENT SENSOR	26
8	Exploded View	26
FOR USA AND CANADA : Precaution for Supplemental Restraint System (SRS) "AIR BAG" and "SEAT BELT PRE-TENSIONER"	Removal and Installation	26
8	IN-VEHICLE SENSOR	27
FOR MEXICO	Exploded View	27
8	Removal and Installation	27
FOR MEXICO : Precaution for Supplemental Restraint System (SRS) "AIR BAG" and "SEAT BELT PRE-TENSIONER"	SUNLOAD SENSOR	28
8	Exploded View	28
Precaution for Procedure without Cowl Top Cover.....	Removal and Installation	28
9	INTAKE SENSOR	29
Precautions For Xenon Headlamp Service	Exploded View	29
9	Removal and Installation	29
Working with HFC-134a (R-134a)	BLOWER UNIT	30
9	Exploded View	30
General Refrigerant Precaution	Removal and Installation	31
10	BLOWER MOTOR	33
Refrigerant Connection	Exploded View	33
10		
Service Equipment		
12		
COMPRESSOR		
15		
General Precautions		
15		
FLUORESCENT LEAK DETECTOR		
16		
General Precautions		
16		
PREPARATION		
17		
PREPARATION		
17		
Special Service Tool		
17		
Commercial Service Tool		
19		
Sealant or/and Lubricant		
20		

Removal and Installation	33	REAR VENTILATOR DUCT 1	55
INTAKE DOOR MOTOR	34	REAR VENTILATOR DUCT 1 : Exploded View	56
Exploded View	34	REAR VENTILATOR DUCT 1 : Removal and In-	56
Removal and Installation	34	stallation	56
HEATER & COOLING UNIT ASSEMBLY	36	REAR VENTILATOR DUCT 2	57
Exploded View	36	REAR VENTILATOR DUCT 2 : Exploded View	57
Removal and Installation	38	REAR VENTILATOR DUCT 2 : Removal and In-	57
UPPER VENTILATOR DOOR MOTOR	41	stallation	57
Exploded View	41	REAR VENTILATOR DUCT 3	58
Removal and Installation	41	REAR VENTILATOR DUCT 3 : Exploded View	58
MODE DOOR MOTOR	42	REAR VENTILATOR DUCT 3 : Removal and In-	58
Exploded View	42	stallation	58
Removal and Installation	42	REAR VENTILATOR DUCT 4	59
AIR MIX DOOR MOTOR	43	REAR VENTILATOR DUCT 4 : Exploded View	60
Exploded View	43	REAR VENTILATOR DUCT 4 : Removal and In-	60
Removal and Installation	43	stallation	60
HEATER CORE	45	REAR FOOT DUCT 1	60
Exploded View	45	REAR FOOT DUCT 1 : Exploded View	61
Removal and Installation	46	REAR FOOT DUCT 1 : Removal and Installation...	61
DUCT AND GRILLE	47	REAR FOOT DUCT 2	62
CENTER VENTILATOR GRILLE	47	REAR FOOT DUCT 2 : Exploded View	62
CENTER VENTILATOR GRILLE : Exploded View..	47	REAR FOOT DUCT 2 : Removal and Installation...	63
CENTER VENTILATOR GRILLE : Removal and		REAR FOOT DUCT 3	63
Installation	47	REAR FOOT DUCT 3 : Exploded View	64
SIDE VENTILATOR GRILLE	48	REAR FOOT DUCT 3 : Removal and Installation...	64
SIDE VENTILATOR GRILLE : Exploded View	48	HEATER DUCT	65
SIDE VENTILATOR GRILLE : Removal and In-		HEATER DUCT : Exploded View	65
stallation	48	HEATER DUCT : Removal and Installation	66
SIDE DEFROSTER GRILLE	49	FOOT DUCT	66
SIDE DEFROSTER GRILLE : Exploded View	49	FOOT DUCT : Exploded View	67
SIDE DEFROSTER GRILLE : Removal and In-		FOOT DUCT : Removal and Installation	67
stallation	50	WITH 7 INCH DISPLAY	
VENTILATOR DUCT	50	SYSTEM DESCRIPTION	69
VENTILATOR DUCT : Exploded View	50	SWITCHES AND THEIR CONTROL FUNC-	
VENTILATOR DUCT : Removal and Installation ...	51	TION	69
UPPER VENTILATOR DUCT	51	System Description	69
UPPER VENTILATOR DUCT : Exploded View	52	AIR DISTRIBUTION	71
UPPER VENTILATOR DUCT : Removal and In-		System Description	71
stallation	52	PRECAUTION	72
DEFROSTER NOZZLE AND SIDE DEFROSTER		PRECAUTIONS	72
NOZZLE	53	FOR USA AND CANADA	72
DEFROSTER NOZZLE AND SIDE DEFROSTER		FOR USA AND CANADA : Precaution for Supple-	
NOZZLE : Exploded View	53	mental Restraint System (SRS) "AIR BAG" and	
DEFROSTER NOZZLE AND SIDE DEFROSTER		"SEAT BELT PRE-TENSIONER"	72
NOZZLE : Removal and Installation	53	FOR MEXICO	72
REAR VENTILATOR GRILLE	54	FOR MEXICO : Precaution for Supplemental Re-	
REAR VENTILATOR GRILLE : Exploded View	54	straint System (SRS) "AIR BAG" and "SEAT BELT	
REAR VENTILATOR GRILLE : Removal and In-		PRE-TENSIONER"	72
stallation	55		

Precaution for Procedure without Cowl Top Cover... 73	Exploded View96	
Precautions For Xenon Headlamp Service 73	Removal and Installation96	A
Working with HFC-134a (R-134a) 73		
General Refrigerant Precaution 74	HEATER & COOLING UNIT ASSEMBLY98	
Refrigerant Connection 74	Exploded View98	B
Service Equipment 76	Removal and Installation 100	
COMPRESSOR79	UPPER VENTILATOR DOOR MOTOR 103	
General Precautions 79	Exploded View 103	C
FLUORESCENT LEAK DETECTOR80	Removal and Installation 103	
General Precautions 80	MODE DOOR MOTOR 104	
PREPARATION81	Exploded View 104	D
PREPARATION81	Removal and Installation 104	
Special Service Tool 81	AIR MIX DOOR MOTOR 105	
Commercial Service Tool 83	Exploded View 105	E
Sealant or/and Lubricant 84	Removal and Installation 105	
PERIODIC MAINTENANCE85	HEATER CORE 107	
IN-CABIN MICROFILTER85	Exploded View 107	F
Exploded View 85	Removal and Installation 108	
Removal and Installation 85	DUCT AND GRILLE 109	G
Replacement 85	CENTER VENTILATOR GRILLE 109	
REMOVAL AND INSTALLATION86	CENTER VENTILATOR GRILLE : Exploded View. 109	H
PRESET SWITCH86	CENTER VENTILATOR GRILLE : Removal and Installation 109	
Exploded View 86	SIDE VENTILATOR GRILLE110	VTL
Removal and Installation 86	SIDE VENTILATOR GRILLE : Exploded View 110	
A/C AUTO AMP.87	SIDE VENTILATOR GRILLE : Removal and Installation 110	J
Exploded View 87	SIDE DEFROSTER GRILLE111	
Removal and Installation 87	SIDE DEFROSTER GRILLE : Exploded View 111	K
AMBIENT SENSOR88	SIDE DEFROSTER GRILLE : Removal and Installation 112	
Exploded View 88	VENTILATOR DUCT112	L
Removal and Installation 88	VENTILATOR DUCT : Exploded View 112	
IN-VEHICLE SENSOR89	VENTILATOR DUCT : Removal and Installation .. 113	M
Exploded View 89	UPPER VENTILATOR DUCT113	
Removal and Installation 89	UPPER VENTILATOR DUCT : Exploded View 114	N
SUNLOAD SENSOR90	UPPER VENTILATOR DUCT : Removal and Installation 114	
Exploded View 90	DEFROSTER NOZZLE AND SIDE DEFROSTER NOZZLE115	O
Removal and Installation 90	DEFROSTER NOZZLE AND SIDE DEFROSTER NOZZLE : Exploded View 115	
INTAKE SENSOR91	DEFROSTER NOZZLE AND SIDE DEFROSTER NOZZLE : Removal and Installation 115	P
Exploded View 91	REAR VENTILATOR GRILLE116	
Removal and Installation 91	REAR VENTILATOR GRILLE : Exploded View ... 116	
BLOWER UNIT92	REAR VENTILATOR GRILLE : Removal and Installation 117	
Exploded View 92	REAR VENTILATOR DUCT 1117	
Removal and Installation 93	REAR VENTILATOR DUCT 1 : Exploded View ... 118	
BLOWER MOTOR95		
Exploded View 95		
Removal and Installation 95		
INTAKE DOOR MOTOR96		

REAR VENTILATOR DUCT 1 : Removal and Installation	118	REAR FOOT DUCT 1 : Exploded View	123
REAR VENTILATOR DUCT 1 : Removal and Installation	118	REAR FOOT DUCT 1 : Removal and Installation	123
REAR VENTILATOR DUCT 2	119	REAR FOOT DUCT 2	124
REAR VENTILATOR DUCT 2 : Exploded View ...	119	REAR FOOT DUCT 2 : Exploded View	124
REAR VENTILATOR DUCT 2 : Removal and Installation	119	REAR FOOT DUCT 2 : Removal and Installation	125
REAR VENTILATOR DUCT 3	120	REAR FOOT DUCT 3	125
REAR VENTILATOR DUCT 3 : Exploded View ...	120	REAR FOOT DUCT 3 : Exploded View	126
REAR VENTILATOR DUCT 3 : Removal and Installation	120	REAR FOOT DUCT 3 : Removal and Installation	126
REAR VENTILATOR DUCT 4	121	HEATER DUCT	127
REAR VENTILATOR DUCT 4 : Exploded View ...	122	HEATER DUCT : Exploded View	127
REAR VENTILATOR DUCT 4 : Removal and Installation	122	HEATER DUCT : Removal and Installation	128
REAR FOOT DUCT 1	122	FOOT DUCT	128
		FOOT DUCT : Exploded View	129
		FOOT DUCT : Removal and Installation	129

SWITCHES AND THEIR CONTROL FUNCTION

< SYSTEM DESCRIPTION >

[WITHOUT 7 INCH DISPLAY]

SYSTEM DESCRIPTION

SWITCHES AND THEIR CONTROL FUNCTION

System Description

INFOID:000000006258528

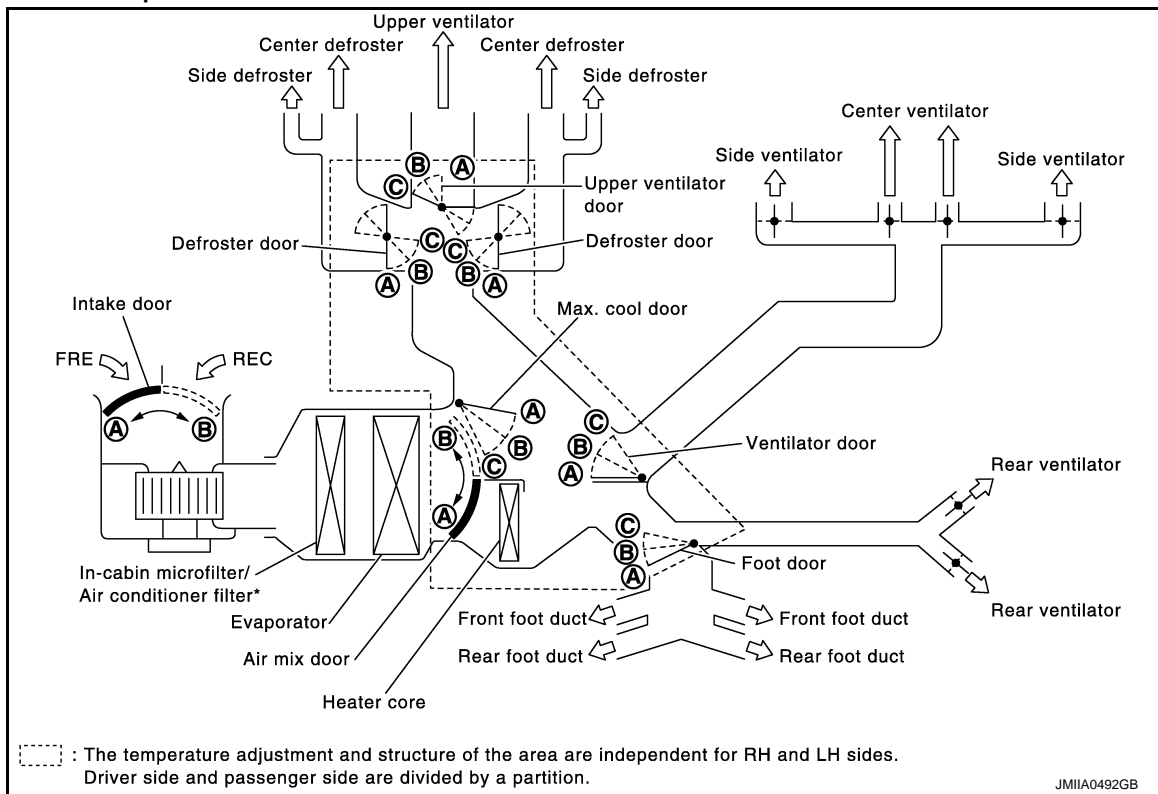



* : Models for Mexico.

Switch position			Door position						
			Ventilator door	Max. cool door	Defroster door	Foot door	Upper ventilator door	Intake door	Air mix door (Driver side)
AUTO switch	☀		AUTO					AUTO	
MODE switch	VENT	☂	A	A	A	A	—	—	—
	B/L	☂	B	B	A	B			
	FOOT	☂	C	B	B	C			
	D/F	☂	C	B	B	B		B	
DEF switch	☂	☀	C	C	C	A	B		
UPPER VENT switch	ON	☂ ☀	—				A-B	—	
	OFF	☂ ○	—				C	—	

SWITCHES AND THEIR CONTROL FUNCTION

< SYSTEM DESCRIPTION >

[WITHOUT 7 INCH DISPLAY]

Switch position				Door position															
				Ventilator door	Max. cool door	Defroster door	Foot door	Upper ventilator door	Intake door	Air mix door (Driver side)	Air mix door (Passenger side)								
Intake switch	ON			—	—	—	—	—	A*	—	—								
	OFF		○						B*										
Temperature control switch (Driver side)	DUAL switch: OFF	18.0°C (60°F) 18.5°C ⇔ 31.5°C (61°F ⇔ 89°F) 32.0°C (90°F)	—						—			—	—	—	—	—	A	—	
																			AUTO
																			B
Temperature control switch (Driver side)	DUAL switch: ON	18.0°C (60°F) 18.5°C ⇔ 31.5°C (61°F ⇔ 89°F) 32.0°C (90°F)	—						—			—	—	—	—	—	A	—	
																	AUTO		
																	B		
Temperature control switch (Passenger side)	ON	18.0°C (60°F) 18.5°C ⇔ 31.5°C (61°F ⇔ 89°F) 32.0°C (90°F)	—						—			—	—	—	—	—	—	A	
																		AUTO	
				B															
ON/OFF switch				C	C	B	C	—	B	—	—								

*: Inlet status is displayed by indicator when activating automatic control.

AIR DISTRIBUTION





< SYSTEM DESCRIPTION >

[WITHOUT 7 INCH DISPLAY]





AIR DISTRIBUTION

System Description

INFOID:000000006258529

Discharge air flow							
Mode position indication	Condition	Air outlet/distribution					
		VENT			FOOT		DEF
		Front	Upper	Rear	Front	Rear	
	DUAL switch: OFF UPPER VENT switch : ON	81%	8%	11%	—	—	—
		41%	10%	17%	24%	8%	—
		12%	12%	16%	27%	10%	23%
		11%	11%	14%	25%	10%	29%
		11%	11%	12%	—	—	66%

JPIIA0509GB

Discharge air flow							
Mode position indication	Condition	Air outlet/distribution					
		VENT			FOOT		DEF
		Front	Upper	Rear	Front	Rear	
	DUAL switch: OFF UPPER VENT switch : OFF	88%	—	12%	—	—	—
		47%	—	18%	26%	9%	—
		13%	—	17%	33%	12%	25%
		12%	—	16%	28%	12%	32%
		11%	—	15%	—	—	74%

JPIIA0510GB

A
B
C
D
E
F
G
H
VTL
J
K
L
M
N
O
P

PRECAUTION

PRECAUTIONS

FOR USA AND CANADA

FOR USA AND CANADA : Precaution for Supplemental Restraint System (SRS) "AIR BAG" and "SEAT BELT PRE-TENSIONER"

INFOID:000000006258530

The Supplemental Restraint System such as "AIR BAG" and "SEAT BELT PRE-TENSIONER", used along with a front seat belt, helps to reduce the risk or severity of injury to the driver and front passenger for certain types of collision. This system includes seat belt switch inputs and dual stage front air bag modules. The SRS system uses the seat belt switches to determine the front air bag deployment, and may only deploy one front air bag, depending on the severity of a collision and whether the front occupants are belted or unbelted. Information necessary to service the system safely is included in the "SRS AIR BAG" and "SEAT BELT" of this Service Manual.

WARNING:

Always observe the following items for preventing accidental activation.

- To avoid rendering the SRS inoperative, which could increase the risk of personal injury or death in the event of a collision that would result in air bag inflation, all maintenance must be performed by an authorized NISSAN/INFINITI dealer.
- Improper maintenance, including incorrect removal and installation of the SRS, can lead to personal injury caused by unintentional activation of the system. For removal of Spiral Cable and Air Bag Module, see "SRS AIR BAG".
- Never use electrical test equipment on any circuit related to the SRS unless instructed to in this Service Manual. SRS wiring harnesses can be identified by yellow and/or orange harnesses or harness connectors.

PRECAUTIONS WHEN USING POWER TOOLS (AIR OR ELECTRIC) AND HAMMERS

WARNING:

Always observe the following items for preventing accidental activation.

- When working near the Air Bag Diagnosis Sensor Unit or other Air Bag System sensors with the ignition ON or engine running, never use air or electric power tools or strike near the sensor(s) with a hammer. Heavy vibration could activate the sensor(s) and deploy the air bag(s), possibly causing serious injury.
- When using air or electric power tools or hammers, always switch the ignition OFF, disconnect the battery, and wait at least 3 minutes before performing any service.

FOR MEXICO

FOR MEXICO : Precaution for Supplemental Restraint System (SRS) "AIR BAG" and "SEAT BELT PRE-TENSIONER"

INFOID:000000006258531

The Supplemental Restraint System such as "AIR BAG" and "SEAT BELT PRE-TENSIONER", used along with a front seat belt, helps to reduce the risk or severity of injury to the driver and front passenger for certain types of collision. Information necessary to service the system safely is included in the "SRS AIR BAG" and "SEAT BELT" of this Service Manual.

WARNING:

Always observe the following items for preventing accidental activation.

- To avoid rendering the SRS inoperative, which could increase the risk of personal injury or death in the event of a collision that would result in air bag inflation, all maintenance must be performed by an authorized NISSAN/INFINITI dealer.
- Improper maintenance, including incorrect removal and installation of the SRS, can lead to personal injury caused by unintentional activation of the system. For removal of Spiral Cable and Air Bag Module, see "SRS AIR BAG".
- Never use electrical test equipment on any circuit related to the SRS unless instructed to in this Service Manual. SRS wiring harnesses can be identified by yellow and/or orange harnesses or harness connectors.

PRECAUTIONS WHEN USING POWER TOOLS (AIR OR ELECTRIC) AND HAMMERS

WARNING:

PRECAUTIONS

< PRECAUTION >

[WITHOUT 7 INCH DISPLAY]

Always observe the following items for preventing accidental activation.

- When working near the Air Bag Diagnosis Sensor Unit or other Air Bag System sensors with the ignition ON or engine running, never use air or electric power tools or strike near the sensor(s) with a hammer. Heavy vibration could activate the sensor(s) and deploy the air bag(s), possibly causing serious injury.
- When using air or electric power tools or hammers, always switch the ignition OFF, disconnect the battery, and wait at least 3 minutes before performing any service.

Precaution for Procedure without Cowl Top Cover

INFOID:000000006258533

When performing the procedure after removing cowl top cover, cover the lower end of windshield with urethane, etc to prevent damage to windshield.

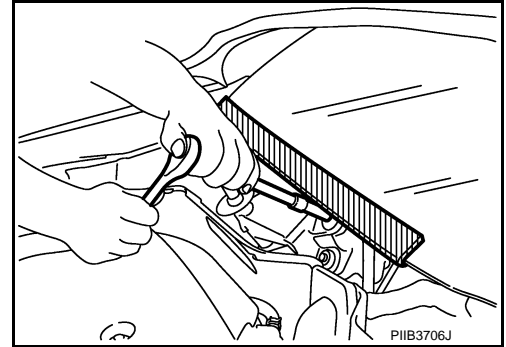

Precautions For Xenon Headlamp Service

INFOID:000000006258534

WARNING:

Comply with the following warnings to prevent any serious accident.

- Disconnect the battery cable (negative terminal) or the power supply fuse before installing, removing, or touching the xenon headlamp (bulb included). The xenon headlamp contains high-voltage generated parts.
- Never work with wet hands.
- Check the xenon headlamp ON-OFF status after assembling it to the vehicle. Never turn the xenon headlamp ON in other conditions. Connect the power supply to the vehicle-side connector. (Turning it ON outside the lamp case may cause fire or visual impairments.)
- Never touch the bulb glass immediately after turning it OFF. It is extremely hot.

CAUTION:

Comply with the following cautions to prevent any error and malfunction.

- Install the xenon bulb securely. (Insufficient bulb socket installation may melt the bulb, the connector, the housing, etc. by high-voltage leakage or corona discharge.)
- Never perform HID circuit inspection with a tester.
- Never touch the xenon bulb glass with hands. Never put oil and grease on it.
- Dispose of the used xenon bulb after packing it in thick vinyl without breaking it.
- Never wipe out dirt and contamination with organic solvent (thinner, gasoline, etc.).

Working with HFC-134a (R-134a)

INFOID:000000006258535

CAUTION:

- CFC-12 (R-12) refrigerant and HFC-134a (R-134a) refrigerant are not compatible. Compressor malfunction is likely to occur if the refrigerants are mixed, refer to "CONTAMINATED REFRIGERANT" below. To determine the purity of HFC-134a (R-134a) in the vehicle and recovery tank, use Refrigerant Recovery/Recycling Recharging equipment and Refrigerant Identifier.
- Use only specified lubricant for the HFC-134a (R-134a) A/C system and HFC-134a (R-134a) components. Compressor malfunction is likely to occur if lubricant other than that specified is used.
- The specified HFC-134a (R-134a) lubricant rapidly absorbs moisture from the atmosphere. The following handling precautions must be observed:
 - Immediately cap (seal) immediately the component to minimize the entry of moisture from the atmosphere when removing refrigerant components from a vehicle.
 - Never remove the caps (unseal) until just before connecting the components when installing refrigerant components to a vehicle. Connect all refrigerant loop components as quickly as possible to minimize the entry of moisture into system.
 - Use only the specified lubricant from a sealed container. Immediately reseal containers of lubricant. Lubricant becomes saturated with moisture and should not be used without proper sealing.

PRECAUTIONS

< PRECAUTION >

[WITHOUT 7 INCH DISPLAY]

- **Never allow lubricant (NISSAN A/C System Oil Type S) to come in to contact with styrene foam parts. Damage may result.**

CONTAMINATED REFRIGERANT

Take the appropriate steps shown below if a refrigerant other than pure HFC-134a (R-134a) is identified in a vehicle:

- Explain to the customer that environmental regulations prohibit the release of contaminated refrigerant into the atmosphere.
- Explain that recovery of the contaminated refrigerant could damage service equipment and refrigerant supply.
- Suggest the customer return the vehicle to the location of previous service where the contamination may have occurred.
- If repairing, recover the refrigerant using only **dedicated equipment and containers. Never reintroduce contaminated refrigerant into the existing service equipment.** Contact a local refrigerant product retailer for available service if the facility does not have dedicated recovery equipment. This refrigerant must be disposed of in accordance with all federal and local regulations. In addition, replacement of all refrigerant system components on the vehicle is recommended.
- The air conditioner warranty is void if the vehicle is within the warranty period. Please contact Nissan Customer Affairs for further assistance.

General Refrigerant Precaution

INFOID:000000006258536

WARNING:

- **Never breathe A/C refrigerant and lubricant vapor or mist. Exposure may irritate eyes, nose or throat. Remove HFC-134a (R-134a) from the A/C system, using certified service equipment meeting requirements of SAE J-2210 [HFC-134a (R-134a) recycling equipment], or J-2209 [HFC-134a (R-134a) recovery equipment]. Ventilate the work area before resuming service if accidental system discharge occurs. Additional health and safety information may be obtained from refrigerant and lubricant manufacturers.**
- **Never release refrigerant into the air. Use approved recovery/recycling equipment to capture the refrigerant each time an air conditioning system is discharged.**
- **Always wear eye and hand protection (goggles and gloves) when working with any refrigerant or air conditioning system.**
- **Never store or heat refrigerant containers above 52°C (126°F).**
- **Never heat a refrigerant container with an open flame. Place the bottom of the container in a warm pail of water if container warming is required.**
- **Never intentionally drop, puncture, or incinerate refrigerant containers.**
- **Keep refrigerant away from open flames. Poisonous gas is produced if refrigerant burns.**
- **Refrigerant displaces oxygen, therefore be certain to work in well ventilated areas to prevent suffocation.**
- **Never pressure test or leakage test HFC-134a (R-134a) service equipment and/or vehicle air conditioning systems with compressed air during repair. Some mixtures of air and HFC-134a (R-134a) have proven to be combustible at elevated pressures. These mixtures, if ignited, may cause injury or property damage. Additional health and safety information may be obtained from refrigerant manufacturers.**

Refrigerant Connection

INFOID:000000006258537

A new type refrigerant connection has been introduced to all refrigerant lines except the following locations.

- Expansion valve to evaporator
- Refrigerant pressure sensor to liquid tank

O-RING AND REFRIGERANT CONNECTION

PRECAUTIONS

< PRECAUTION >

[WITHOUT 7 INCH DISPLAY]

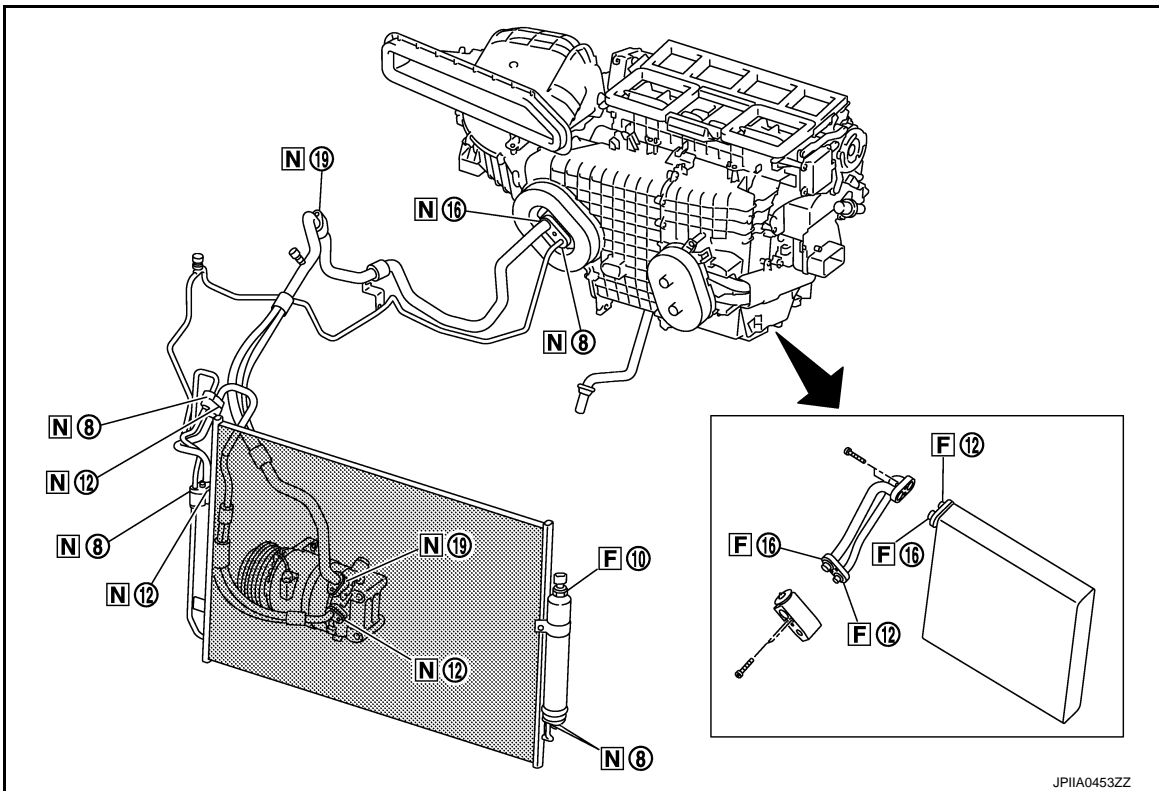

F. Former type refrigerant connection N. New type refrigerant connection
 O: O-ring size

CAUTION:

The new and former refrigerant connections use different O-ring configurations. Never confuse O-rings since they are not interchangeable. Refrigerant may leak at the connection if an incorrect O-ring is installed.

O-Ring Part Numbers and Specifications

Connection type	Piping connection point		Part number	QTY	O-ring size
New	Low-pressure flexible hose to low-pressure pipe		92474 N8210	1	φ19
	High-pressure pipe to condenser pipe assembly (Outlet)		92471 N8210	1	φ8
	Condenser pipe assembly (Inlet) to high-pressure flexible hose (One-touch joint)		92472 N8210	1	φ12
	Condenser assembly to condenser pipe assembly	Inlet	92472 N8210	1	φ12
		Outlet	92471 N8210	1	φ8
	Low-pressure pipe to expansion valve		92473 N8210	1	φ16
	High-pressure pipe to expansion valve		92471 N8210	1	φ8
	Compressor to low-pressure flexible hose		92474 N8210	1	φ19
	Compressor to high-pressure flexible hose		92472 N8210	1	φ12
Liquid tank to condenser assembly	Inlet	92471 N8210	1	φ8	
	Outlet		1		
Former	Refrigerant pressure sensor to liquid tank		J2476 89956	1	φ10
	Expansion valve to evaporator pipe assembly	Inlet	92475 71L00	1	φ12
		Outlet	92475 72L00	1	φ16
	Evaporator to evaporator pipe assembly	Inlet	92475 71L00	1	φ12
Outlet		92475 72L00	1	φ16	

A
B
C
D
E
F
G
H

VTL

J
K
L
M
N
O
P

PRECAUTIONS

< PRECAUTION >

[WITHOUT 7 INCH DISPLAY]

WARNING:

Check that all refrigerant is discharged into the recycling equipment and the pressure in the system is less than the atmospheric pressure. Then gradually loosen the discharge side hose fitting and remove it.

CAUTION:

Observe the following items when replacing or cleaning refrigerant cycle components.

- Store it in the same way as it is when mounted on the car when the compressor is removed. Failure to do so will cause lubricant to enter the low-pressure chamber.
- Always use a torque wrench and a back-up wrench when connecting tubes.
- Immediately plug all openings to prevent entry of dust and moisture after disconnecting tubes.
- Connect the pipes at the final stage of the operation when installing an air conditioner in the vehicle. Never remove the seal caps of pipes and other components until just before they are required for connection.
- Allow components stored in cool areas to warm to working area temperature before removing seal caps. This prevents condensation from forming inside A/C components.
- Thoroughly remove moisture from the refrigeration system before charging the refrigerant.
- Always replace used O-rings.
- Apply lubricant to the circle of the O-rings shown in illustration when a connecting tube. Never apply lubricant to threaded portion.

Name : NISSAN A/C System Oil Type S

- O-ring must be closely attached to the groove portion of tube.
- Never damage O-ring and tube when replacing the O-ring.
- Connect tube until a click can be heard. Then tighten the nut or bolt by hand. Check that the O-ring is installed to the tube correctly.
- Perform leakage test and check that there is no leakage from connections after connecting the line. Disconnect the line and replace the O-ring when the refrigerant leakage point is found. Then tighten the connections of seal seat to the specified torque.

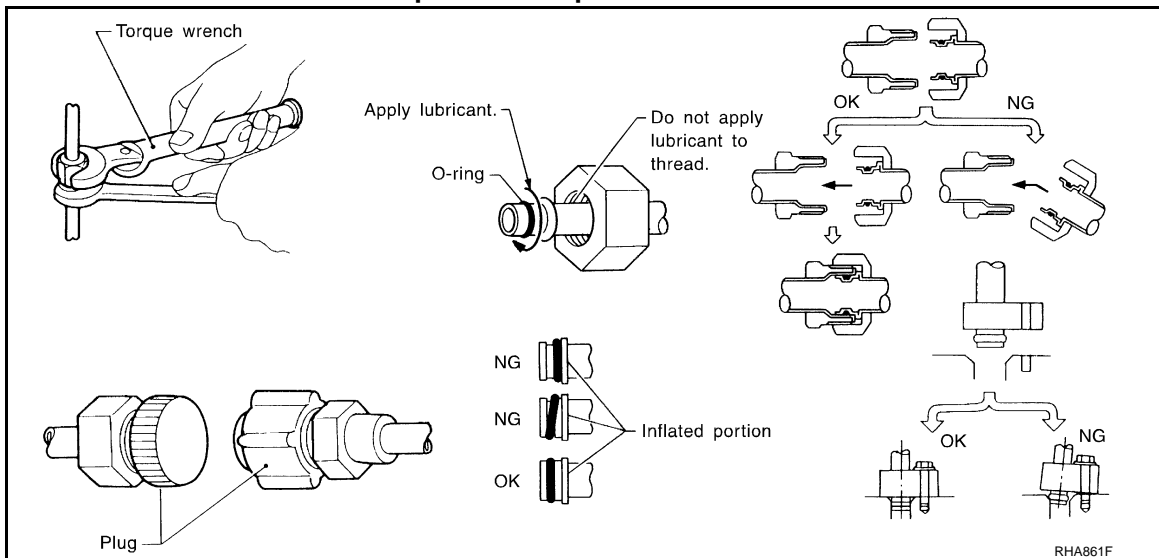

Service Equipment

INFOID:000000006258538

RECOVERY/RECYCLING EQUIPMENT

Be certain to follow the manufacturer instructions for machine operation and machine maintenance. Never introduce any refrigerant other than that specified into the machine.

ELECTRICAL LEAK DETECTOR

Be certain to follow the manufacturer instructions for tester operation and tester maintenance.

VACUUM PUMP

PRECAUTIONS

< PRECAUTION >

The lubricant contained inside the vacuum pump is not compatible with the specified lubricant for HFC-134a (R-134a) A/C systems. The vent side of the vacuum pump is exposed to atmospheric pressure. So the vacuum pump lubricant may migrate out of the pump into the service hose. This is possible when the pump is switched OFF after evacuation (vacuuming) and the hose is connected to it. To prevent this migration, use a manual valve placed near the hose-to-pump connection, as per the following procedure.

- Vacuum pumps usually have a manual isolator valve as part of the pump. Close this valve to isolate the service hose from the pump.
- Use a hose equipped with a manual shut-off valve near the pump end for pumps without an isolator. Close the valve to isolate the hose from the pump.
- Disconnect the hose from the pump if the hose has an automatic shut-off valve. As long as the hose is connected, the valve is open and lubricating oil may migrate.

Some one-way valves open when vacuum is applied and close under the no vacuum condition. Such valves may restrict the ability of the pump to create a deep vacuum and are not recommended.

[WITHOUT 7 INCH DISPLAY]

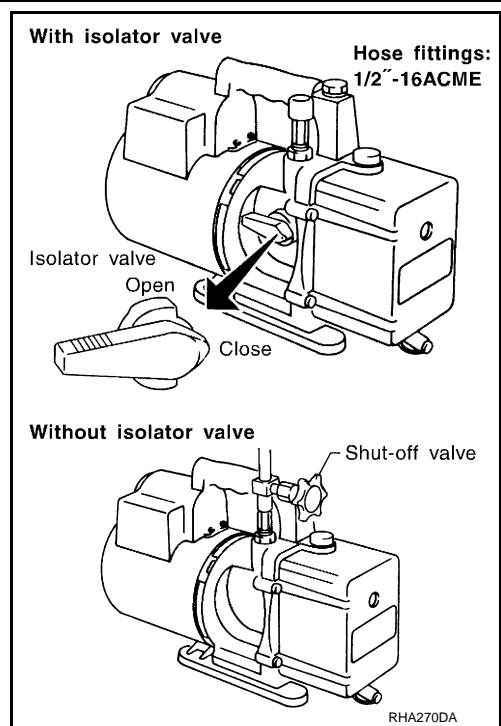

MANIFOLD GAUGE SET

Be certain that the gauge face indicates HFC-134a or R-134a. Be sure the gauge set has 1/2"-16 ACME threaded connections for service hoses. Confirm the set has been used only with refrigerant HFC-134a (R-134a) and specified lubricants.

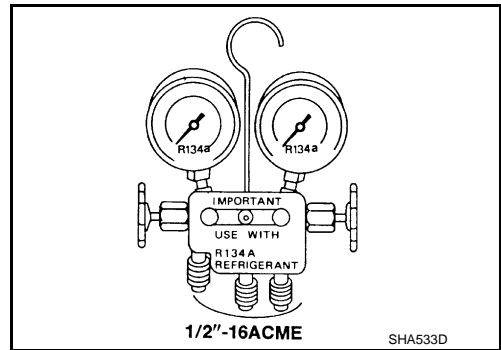

SERVICE HOSES

Be certain that the service hoses display the markings described (colored hose with a black stripe). All hoses must equip positive shut-off devices (either manual or automatic) near the end of the hoses opposite to the manifold gauge.

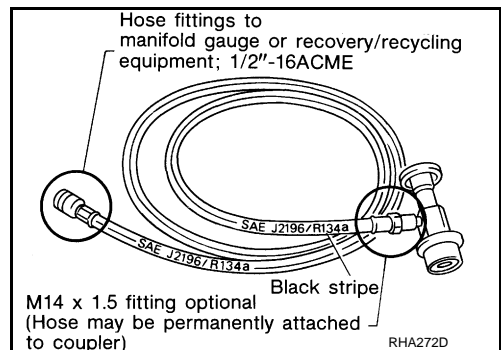

SERVICE COUPLERS

A
B
C
D
E
F
G
H
VTL
J
K
L
M
N
O
P

PRECAUTIONS

< PRECAUTION >

Never attempt to connect HFC-134a (R-134a) service couplers to a CFC-12 (R-12) A/C system. The HFC-134a (R-134a) couplers do not properly connect to the CFC-12 (R-12) system. However, if an improper connection is attempted, discharging and contamination may occur.

Shut-off valve rotation	A/C service valve
Clockwise	Open
Counterclockwise	Close

[WITHOUT 7 INCH DISPLAY]

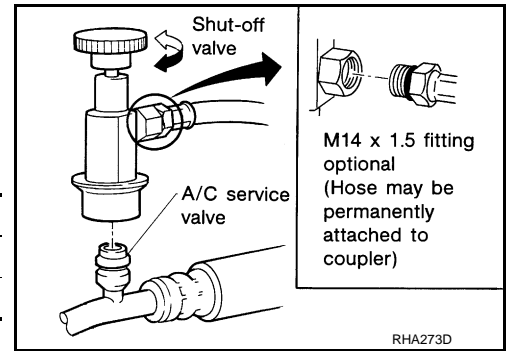

REFRIGERANT WEIGHT SCALE

Verify that no refrigerant other than HFC-134a (R-134a) and specified lubricants have been used with the scale. The hose fitting must be 1/2"-16 ACME if the scale controls refrigerant flow electronically.

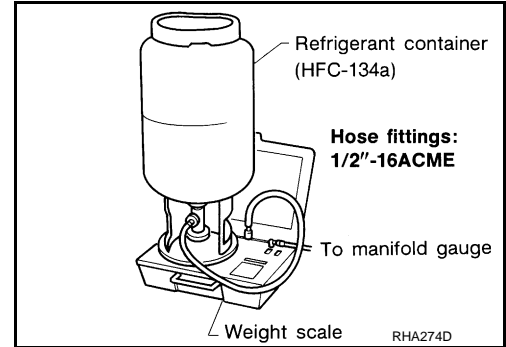

CHARGING CYLINDER

Use of a charging cylinder is not recommended. Refrigerant may be vented into the air from the top valve of the cylinder when filling the cylinder with refrigerant. Also, the accuracy of the cylinder is generally less than that of an electronic scale or of quality recycle/recharge equipment.

COMPRESSOR

General Precautions

INFOID:000000006258539

CAUTION:

- Plug all openings to prevent moisture and foreign material from entering.
- Store it in the same way as it is when mounted on the car when the compressor is removed.
- Follow "Maintenance of Lubricant Quantity in Compressor" exactly when replacing or repairing compressor. Refer to [HA-25, "Maintenance of Lubricant Quantity"](#).
- Keep friction surfaces between clutch and pulley clean. Wipe it off by using a waste moistened with thinner if the surface is contaminated with lubricant.
- Turn the compressor shaft by hand more than five turns in both directions after compressor service operation. This equally distributes lubricant inside the compressor. Let the engine idle and operate the compressor for one hour after the compressor is installed.
- Apply voltage to the new compressor and check for normal operation after replacing the compressor magnet clutch.

A
B
C
D
E
F
G
H
VTL
J
K
L
M
N
O
P

FLUORESCENT LEAK DETECTOR

< PRECAUTION >

[WITHOUT 7 INCH DISPLAY]

FLUORESCENT LEAK DETECTOR

General Precautions

INFOID:000000006258540

CAUTION:

- The A/C system contains a fluorescent leak detection dye used for locating refrigerant leakages. An ultraviolet (UV) lamp is required to illuminate the dye when inspecting for leakages.
- Always wear fluorescence enhancing UV safety goggles to protect eyes and enhance the visibility of the fluorescent dye.
- The fluorescent dye leak detector is not a replacement for an electrical leak detector (SST: J-41995). The fluorescent dye leak detector should be used in conjunction with an electrical leak detector (SST: J-41995) to pin-point refrigerant leakages.
- Read and follow all manufacturer operating instructions and precautions prior to performing work for safety and customer satisfaction.
- A compressor shaft seal should not necessarily be repaired because of dye seepage. The compressor shaft seal should only be repaired after confirming the leakage with an electrical leak detector (SST: J-41995).
- Always remove any remaining dye from the leakage area after repairs are completed to avoid a misdiagnosis during future service.
- Never allow dye to come into contact with painted body panels or interior components. Immediately clean with the approved dye cleaner if dye is spilled. Fluorescent dye left on a surface for an extended period of time cannot be removed.
- Never spray fluorescent dye cleaning agent on hot surfaces (engine exhaust manifold, etc.).
- Never use more than one refrigerant dye bottle [1/4 ounce (7.4 cc)] per A/C system.
- Leak detection dyes for HFC-134a (R-134a) and CFC-12 (R-12) A/C systems are different. Never use HFC-134a (R-134a) leak detection dye in CFC-12 (R-12) A/C system or CFC-12 (R-12) leak detection dye in HFC-134a (R-134a) A/C system, otherwise A/C system damage may result.
- The fluorescent properties of the dye remains for three or more years unless a compressor malfunction occurs.

IDENTIFICATION

NOTE:

Vehicles with factory installed fluorescent dye have a green label.
Vehicles without factory installed fluorescent dye have a blue label.

IDENTIFICATION LABEL FOR VEHICLE

Vehicles with factory installed fluorescent dye have an identification label on the front side of hood.

PREPARATION

< PREPARATION >

[WITHOUT 7 INCH DISPLAY]

PREPARATION

PREPARATION

Special Service Tool

INFOID:000000006258541

The actual shapes of Kent-Moore tools may differ from those of special service tools illustrated here.

HFC-134a (R-134a) Service Tool and Equipment



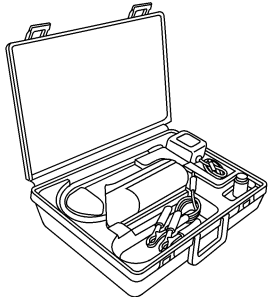
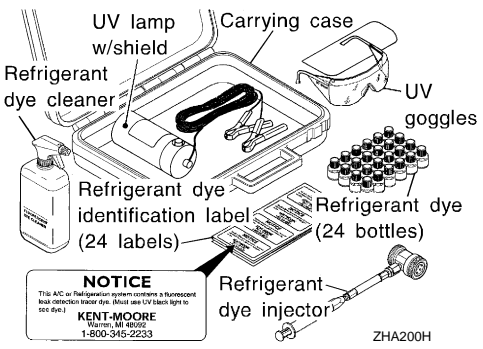

- Never mix HFC-134a (R-134a) refrigerant and/or its specified lubricant with CFC-12 (R-12) refrigerant and/or its lubricant.
- Separate and non-interchangeable service equipment must be used for handling each type of refrigerant/lubricant.
- Refrigerant container fittings, service hose fittings and service equipment fittings (equipment that handles refrigerant and/or lubricant) are different between CFC-12 (R-12) and HFC-134a (R-134a). This is to avoid mixed use of the refrigerants/lubricant.
- Never use adapters that convert one size fitting to another. Refrigerant/lubricant contamination occurs and compressor malfunction may result.

Tool number (Kent-Moore No.) Tool name	Description
<p>(ACR2005-NI) ACR5 A/C Service Center</p>  <p style="text-align: right; font-size: small;">WJIA0293E</p>	<p>Function: Refrigerant recovery, recycling and recharging</p>
<p>(J-41995) Electrical leak detector</p>  <p style="text-align: right; font-size: small;">AHA281A</p>	<p>Power supply: DC 12 V (Battery terminal)</p>
<p>(J-43926) Refrigerant dye leak detection kit Kit includes: (J-42220) UV lamp and UV safety goggles (J-41459) HFC-134a (R-134a) dye injector Use with J-41447, 1/4 ounce bottle (J-41447) HFC-134a (R-134a) fluorescent leak detection dye (Box of 24, 1/4 ounce bottles) (J-43872) Refrigerant dye cleaner</p>  <p style="text-align: right; font-size: small;">ZHA200H</p>	<p>Power supply: DC 12 V (Battery terminal)</p>

PREPARATION

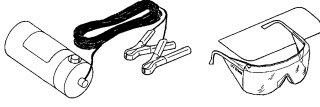
< PREPARATION >

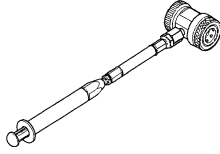
[WITHOUT 7 INCH DISPLAY]

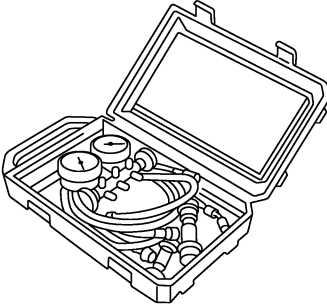
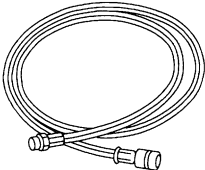
Tool number (Kent-Moore No.) Tool name	Description
<p>(J-42220) UV lamp and UV safety goggles</p>  <p style="text-align: center;">SHA438F</p>	<p>Power supply: DC 12 V (Battery terminal) For checking refrigerant leakage when fluorescent dye is equipped in A/C system Includes: UV lamp and UV safety goggles</p>
<p>(J-41447) HFC-134a (R-134a) fluorescent leak detection dye (Box of 24, 1/4 ounce bottles)</p>  <p style="text-align: center;">Refrigerant dye (24 bottles) SHA439F</p>	<p>Application: For HFC-134a (R-134a) PAG oil Container: 1/4 ounce (7.4 cc) bottle (Includes self-adhesive dye identification labels for affixing to vehicle after charging system with dye.)</p>
<p>(J-41459) HFC-134a (R-134a) dye injector Use with J-41447, 1/4 ounce bottle</p>  <p style="text-align: center;">SHA440F</p>	<p>For injecting 1/4 ounce of fluorescent leak detection dye into A/C system</p>
<p>(J-43872) Refrigerant dye cleaner</p>  <p style="text-align: center;">SHA441F</p>	<p>For cleaning dye spills</p>
<p>(J-39183) Manifold gauge set (with hoses and couplers)</p>  <p style="text-align: center;">RJIA0196E</p>	<p>Identification:</p> <ul style="list-style-type: none"> The gauge face indicates HFC-134a (R-134a). <p>Fitting size: Thread size</p> <ul style="list-style-type: none"> 1/2" -16 ACME
<p>Service hoses</p> <ul style="list-style-type: none"> High-pressure side hose (J-39501-72) Low-pressure side hose (J-39502-72) Utility hose (J-39476-72)  <p style="text-align: center;">S-NT201</p>	<p>Hose color:</p> <ul style="list-style-type: none"> Low-pressure side hose: Blue with black stripe High-pressure side hose: Red with black stripe Utility hose: Yellow with black stripe or green with black stripe <p>Hose fitting to gauge:</p> <ul style="list-style-type: none"> 1/2" -16 ACME

PREPARATION

< PREPARATION >

[WITHOUT 7 INCH DISPLAY]

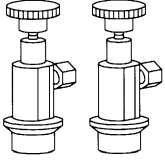
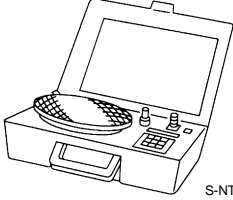
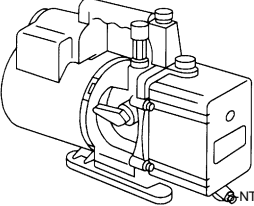
Tool number (Kent-Moore No.) Tool name		Description	
<p>Service couplers</p> <ul style="list-style-type: none"> • High-pressure side coupler (J-39500-20) • Low-pressure side coupler (J-39500-24) 	 <p style="text-align: center; font-size: small;">S-NT202</p>	<p>Hose fitting to service hose: M14 x 1.5 fitting is optional or permanently attached.</p>	A B C
<p>(J-39650) Refrigerant weight scale</p>	 <p style="text-align: center; font-size: small;">S-NT200</p>	<p>For measuring of refrigerant Fitting size: Thread size 1/2" -16 ACME</p>	D E F
<p>(J-39649) Vacuum pump (Including the isolator valve)</p>	 <p style="text-align: center; font-size: small;">S-NT203</p>	<p>Capacity:</p> <ul style="list-style-type: none"> • Air displacement: 4 CFM • Micron rating: 20 microns • Oil capacity: 482 g (17 oz.) <p>Fitting size: Thread size</p> <ul style="list-style-type: none"> • 1/2" -16 ACME 	G H

Commercial Service Tool

INFOID:000000006258542

VTL

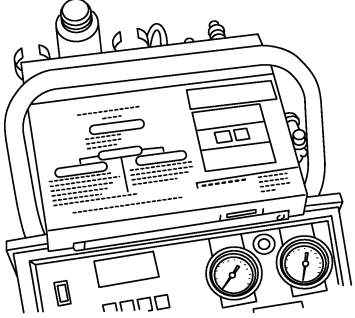
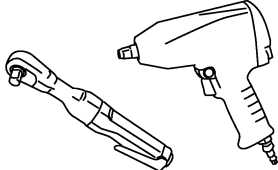
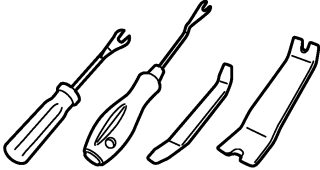
Tool name		Description	
<p>Refrigerant identifier equipment</p>	 <p style="text-align: center; font-size: x-small;">RJIA0197E</p>	<p>Checking for refrigerant purity and system contamination</p>	J K L M
<p>Power tools</p>	 <p style="text-align: center; font-size: x-small;">PBIC0190E</p>	<p>For loosening bolts and nuts</p>	N O
<p>Remover tools</p>	 <p style="text-align: center; font-size: x-small;">JMKIA3050ZZ</p>	<p>Remove clips, pawls, and metal clips</p>	P

PREPARATION

< PREPARATION >



[WITHOUT 7 INCH DISPLAY]

Sealant or/and Lubricant

INFOID:000000006258543

HFC-134a (R-134a) Service Tool and Equipment

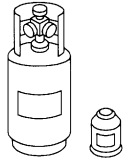
- Never mix HFC-134a (R-134a) refrigerant and/or its specified lubricant with CFC-12 (R-12) refrigerant and/or its lubricant.
- Separate and non-interchangeable service equipment must be used for handling each type of refrigerant/lubricant.
- Refrigerant container fittings, service hose fittings and service equipment fittings (equipment that handles refrigerant and/or lubricant) are different between CFC-12 (R-12) and HFC-134a (R-134a). This is to avoid mixed use of the refrigerants/lubricant.
- Never use adapters that convert one size fitting to another. Refrigerant/lubricant contamination occurs and compressor malfunction may result.

Tool name	Description
<p>HFC-134a (R-134a) refrigerant</p>  <p>S-NT196</p>	<p>Container color: Light blue Container marking: HFC-134a (R-134a) Fitting size: Thread size</p> <ul style="list-style-type: none">• Large container 1/2" -16 ACME
<p>NISSAN A/C System Oil Type S (DH-PS)</p>  <p>S-NT197</p>	<p>Type: Polyalkylene glycol oil (PAG), type S (DH-PS) Application: HFC-134a (R-134a) swash plate compressors (NISSAN only) Capacity: 40 mℓ (1.4 US fl oz., 1.4 Imp fl oz.)</p>

PERIODIC MAINTENANCE

IN-CABIN MICROFILTER

Exploded View

INFOID:000000006258544

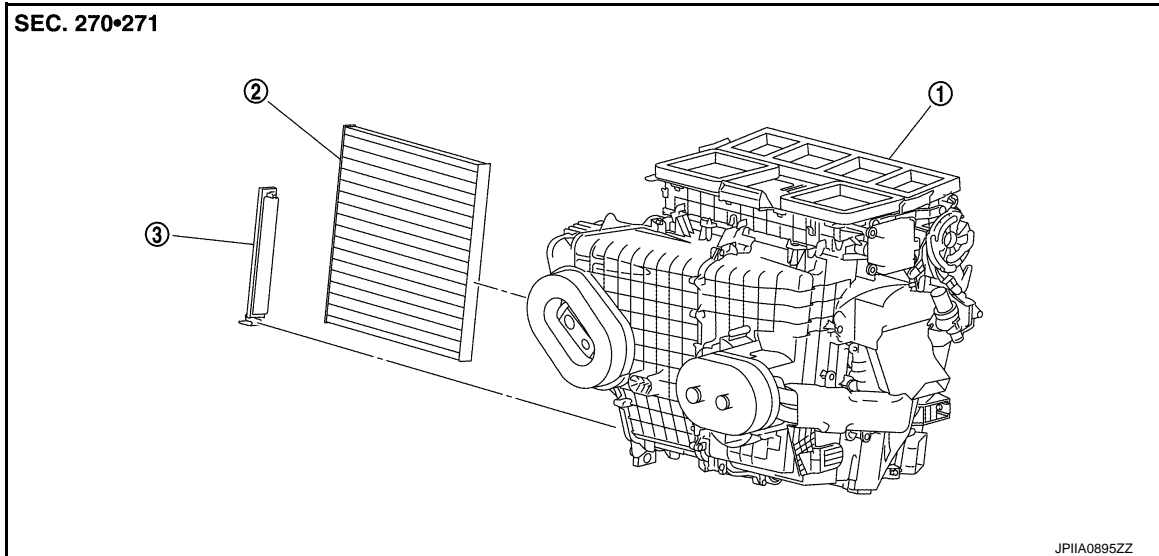

1. Heater & cooling unit assembly 2. In-cabin microfilter/Air conditioner filter* 3. Filter cover

* : Models for Mexico.

A
B
C
D
E
F
G
H

VTL

Removal and Installation

INFOID:000000006258545

REMOVAL

1. Remove the filter cover (1), and then remove the in-cabin microfilter/air conditioner filter (2).

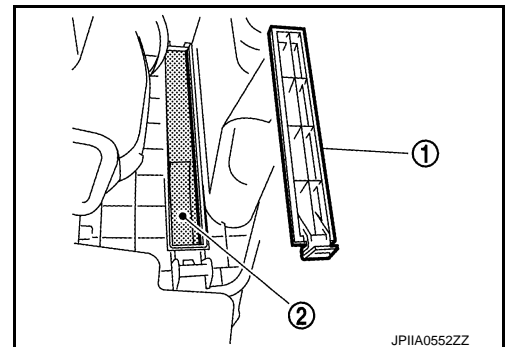

INSTALLATION

Install in the reverse order of removal.

CAUTION:

- If the filter is deformed/damaged when removing, replace it with a new one. Deformed/damaged filter may deteriorate the dust collecting performance.
- When installing, handle the filter with extreme care to avoid deforming/damaging.

Replacement

INFOID:000000006258546

Replace in-cabin microfilter/air conditioner filter.

For NORTH AMERICA : Refer to [MA-8, "FOR NORTH AMERICA : Schedule 1"](#) and [MA-10, "FOR NORTH AMERICA : Schedule 2"](#).

For MEXICO : Refer to [MA-11, "FOR MEXICO : Periodic Maintenance"](#).

Affix a caution label inside the glove box when replacing filter.

J
K
L
M
N
O
P

REMOVAL AND INSTALLATION

A/C CONTROL

Exploded View

INFOID:000000006258547

DISASSEMBLY

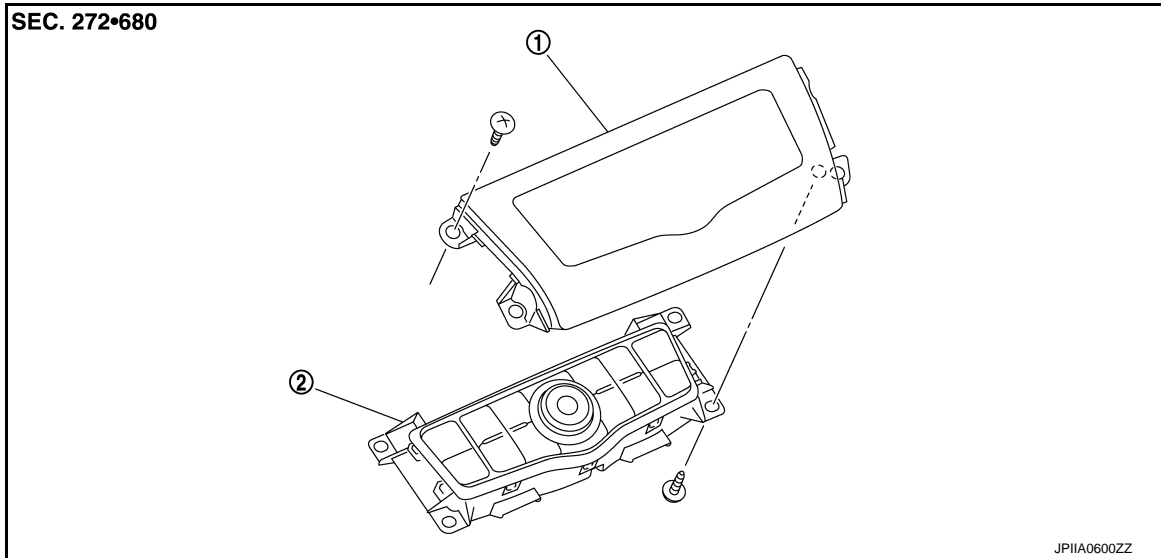

1. Cluster lid D

2. A/C control

Removal and Installation

INFOID:000000006258548

REMOVAL

1. Remove the instrument stay cover LH. Refer to [IP-12, "Exploded View"](#).
2. Remove the instrument stay cover RH. Refer to [IP-12, "Exploded View"](#).
3. Remove the mounting screws (A), and then remove the cluster lid D (1).

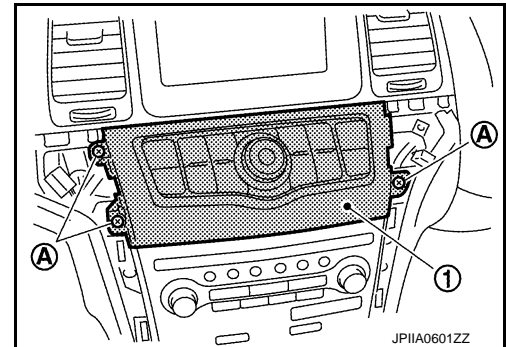

4. Remove the mounting screws (A), and then remove the A/C control (1).

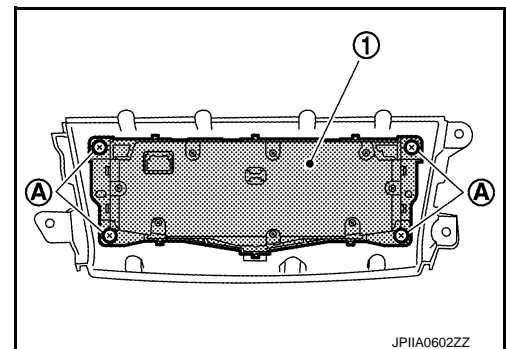

INSTALLATION

A/C CONTROL

< REMOVAL AND INSTALLATION >

[WITHOUT 7 INCH DISPLAY]

Install in the reverse order of removal.

A

B

C

D

E

F

G

H

VTL

J

K

L

M

N

O

P

A/C DISPLAY

< REMOVAL AND INSTALLATION >

[WITHOUT 7 INCH DISPLAY]

A/C DISPLAY

Exploded View

INFOID:000000006258549

DISASSEMBLY

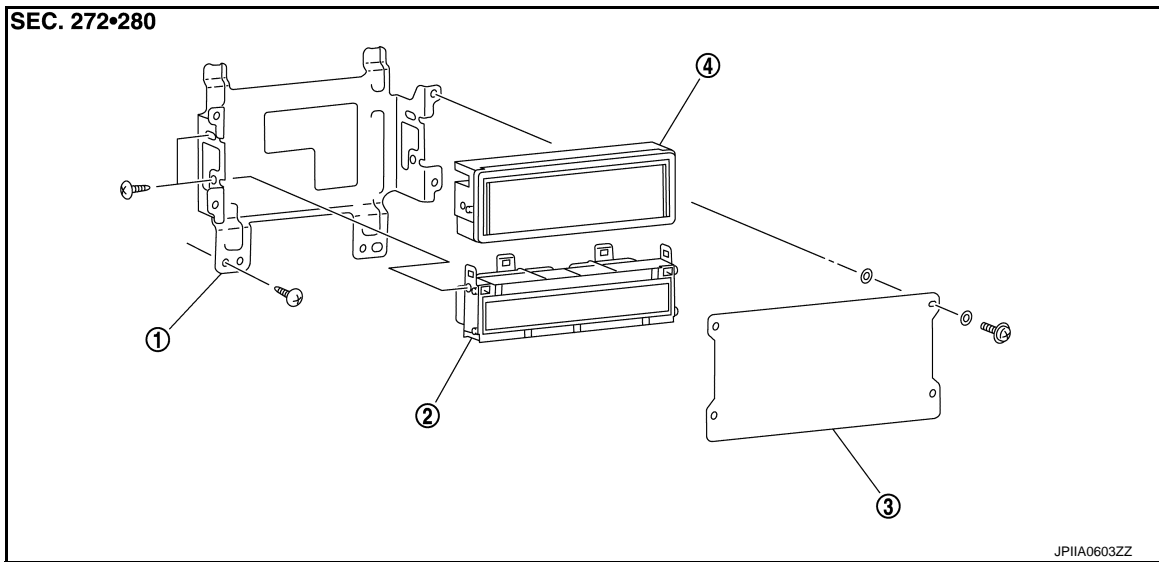

- 1. Bracket
- 2. A/C display
- 3. CRT filter
- 4. AV display

Removal and Installation

INFOID:000000006258550

REMOVAL

1. Remove the central ventilator assembly. Refer to [IP-12, "Exploded View"](#).
2. Remove the mounting screws (A), and then remove the mounting bracket (1).

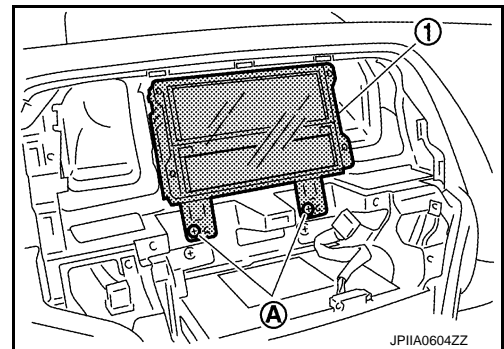

3. Remove the mounting screws (A), and then remove the A/C display (1).

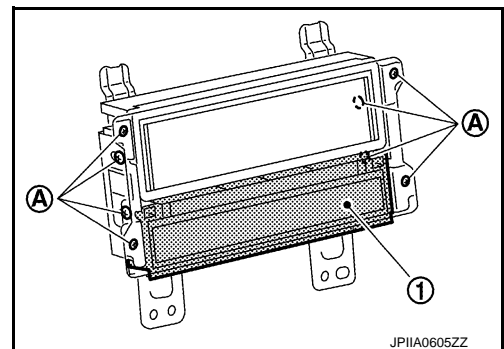

INSTALLATION

Install in the reverse order of removal.

A/C AUTO AMP.

< REMOVAL AND INSTALLATION >

[WITHOUT 7 INCH DISPLAY]

A/C AUTO AMP.

Exploded View

INFOID:000000006258551

DISASSEMBLY

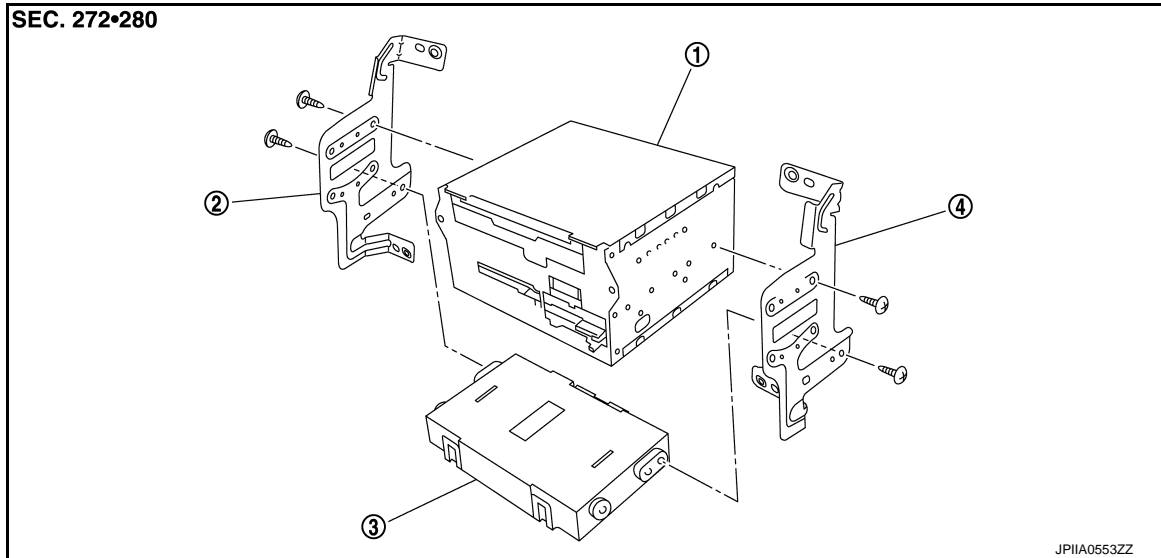

1. AV control unit
2. Bracket (LH)
3. A/C auto amp.
4. Bracket (RH)

Removal and Installation

INFOID:000000006258552

REMOVAL

1. Remove the AV control unit. Refer to [AV-145. "Exploded View"](#).
2. Remove the mounting screws (A), and then remove the A/C auto amp. (1).

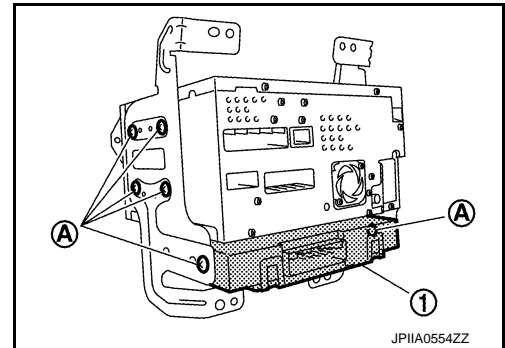

INSTALLATION

Install in the reverse order of removal.

A
B
C
D
E
F
G
H
VTL
J
K
L
M
N
O
P

AMBIENT SENSOR

< REMOVAL AND INSTALLATION >

[WITHOUT 7 INCH DISPLAY]

AMBIENT SENSOR

Exploded View

INFOID:000000006258553

1. Ambient sensor

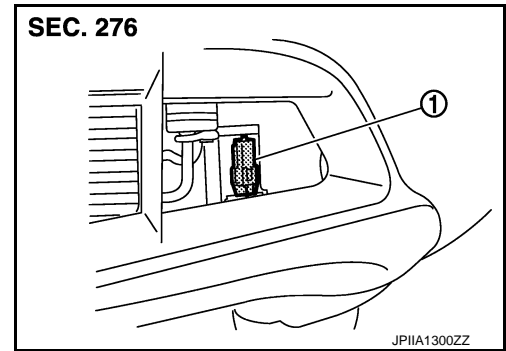

Removal and Installation

INFOID:000000006258554

REMOVAL

1. Disconnect the ambient sensor connector (A), and then remove the ambient sensor (1).

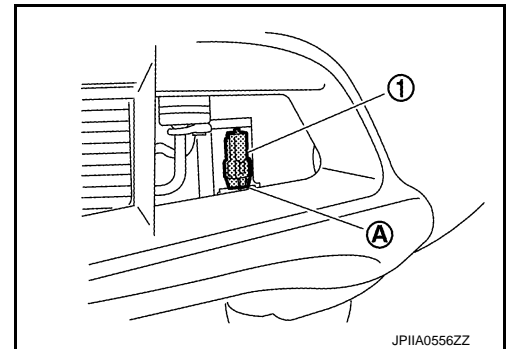

INSTALLATION

Install in the reverse order of removal.

IN-VEHICLE SENSOR

< REMOVAL AND INSTALLATION >

[WITHOUT 7 INCH DISPLAY]

IN-VEHICLE SENSOR

Exploded View

INFOID:000000006258555

1. In-vehicle sensor
2. Instrument lower panel LH

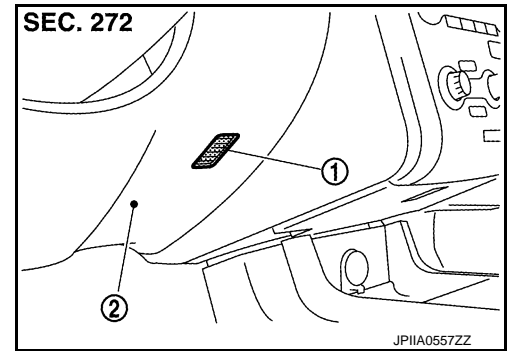

Removal and Installation

INFOID:000000006258556

REMOVAL

1. Remove the instrument lower panel LH. Refer to [IP-12, "Exploded View"](#).
2. Remove the mounting screw (A), and then remove the in-vehicle sensor (1).

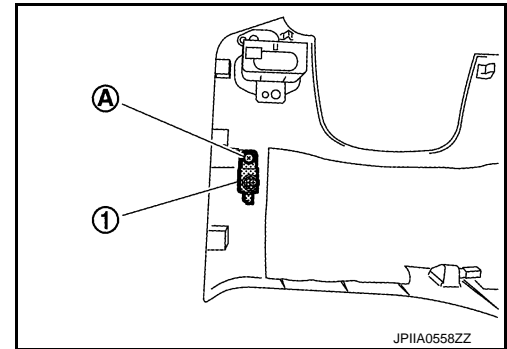

INSTALLATION

Install in the reverse order of removal.

A
B
C
D
E
F
G
H
VTL
J
K
L
M
N
O
P

SUNLOAD SENSOR

< REMOVAL AND INSTALLATION >

[WITHOUT 7 INCH DISPLAY]

SUNLOAD SENSOR

Exploded View

INFOID:000000006258557

1. Sunload sensor

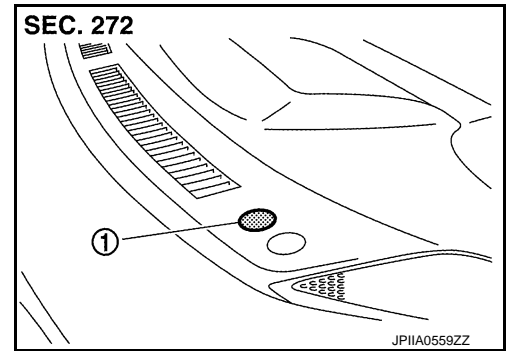

Removal and Installation

INFOID:000000006258558

REMOVAL

1. Disconnect the sunload sensor connector, and then remove the sunload sensor (1).

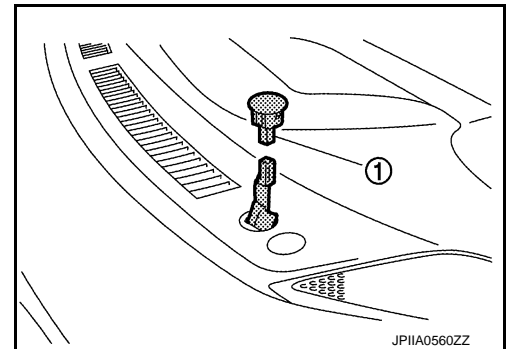

INSTALLATION

Install in the reverse order of removal.

INTAKE SENSOR

< REMOVAL AND INSTALLATION >

[WITHOUT 7 INCH DISPLAY]

INTAKE SENSOR

Exploded View

INFOID:000000006258559

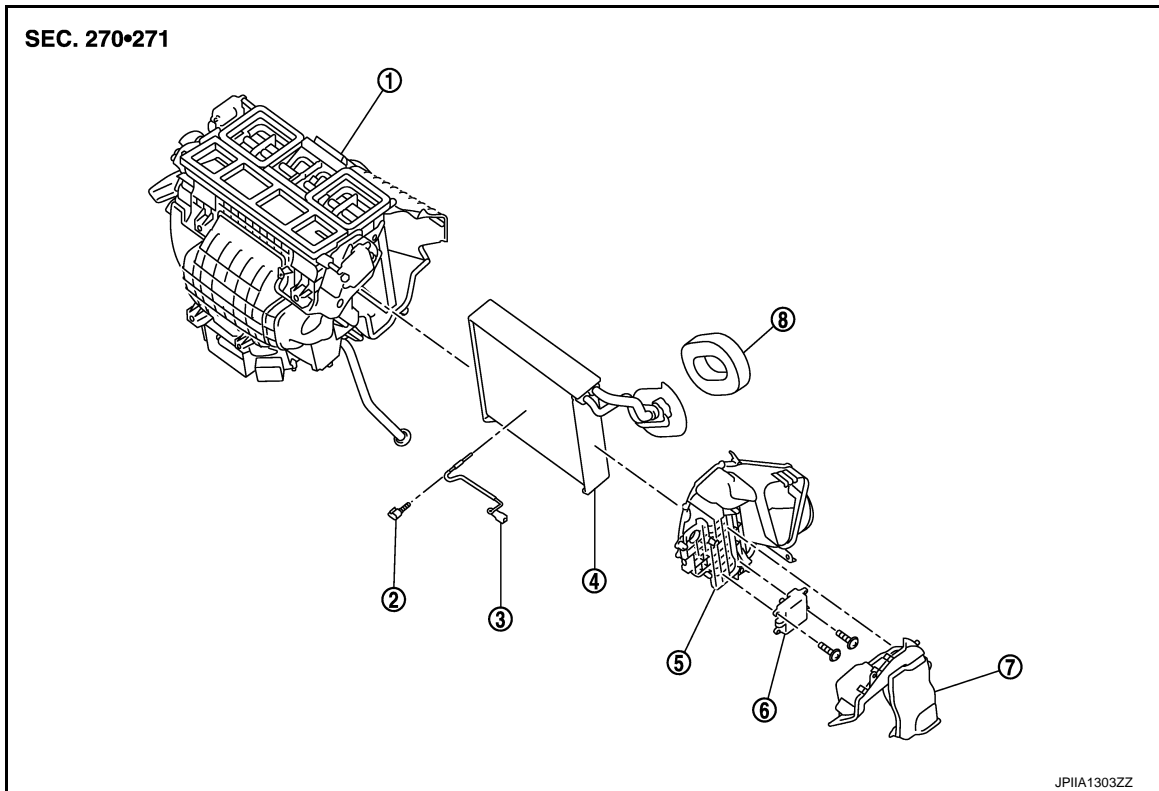

- | | | |
|-----------------------------------|--------------------------|--|
| 1. Heater & cooling unit assembly | 2. Intake sensor bracket | 3. Intake sensor |
| 4. Evaporator assembly | 5. Evaporator cover | 6. Air mix door motor (passenger side) |
| 7. Foot duct (right) | 8. Cooler pipe grummet | |

Removal and Installation

INFOID:000000006258560

REMOVAL

1. Remove the evaporator pipe assembly. Refer to [VTL-36, "Exploded View"](#).
2. Slide the evaporator (1) toward the right side of the vehicle, and then remove the intake sensor (2).

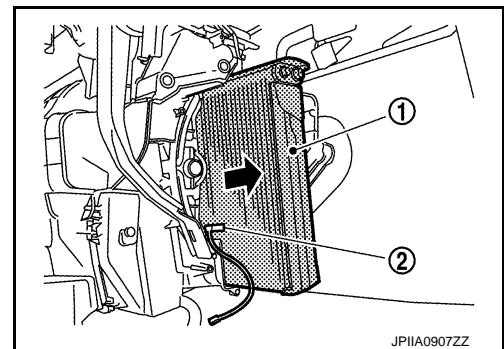

INSTALLATION

Note the following, and install in the reverse order of removal.

CAUTION:

- Replace the O-ring with a new one. Apply a coat of compressor oil to the O-ring prior to installation.
- Install the intake sensor in the same position as the removed intake sensor when replacing the intake sensor.
- Do not rotate the bracket insertion part when removing and installing the intake sensor.
- Check for refrigerant leakage when charging refrigerant.

A
B
C
D
E
F
G
H
VTL
J
K
L
M
N
O
P

BLOWER UNIT

< REMOVAL AND INSTALLATION >

[WITHOUT 7 INCH DISPLAY]

BLOWER UNIT

Exploded View

INFOID:000000006258561

REMOVAL

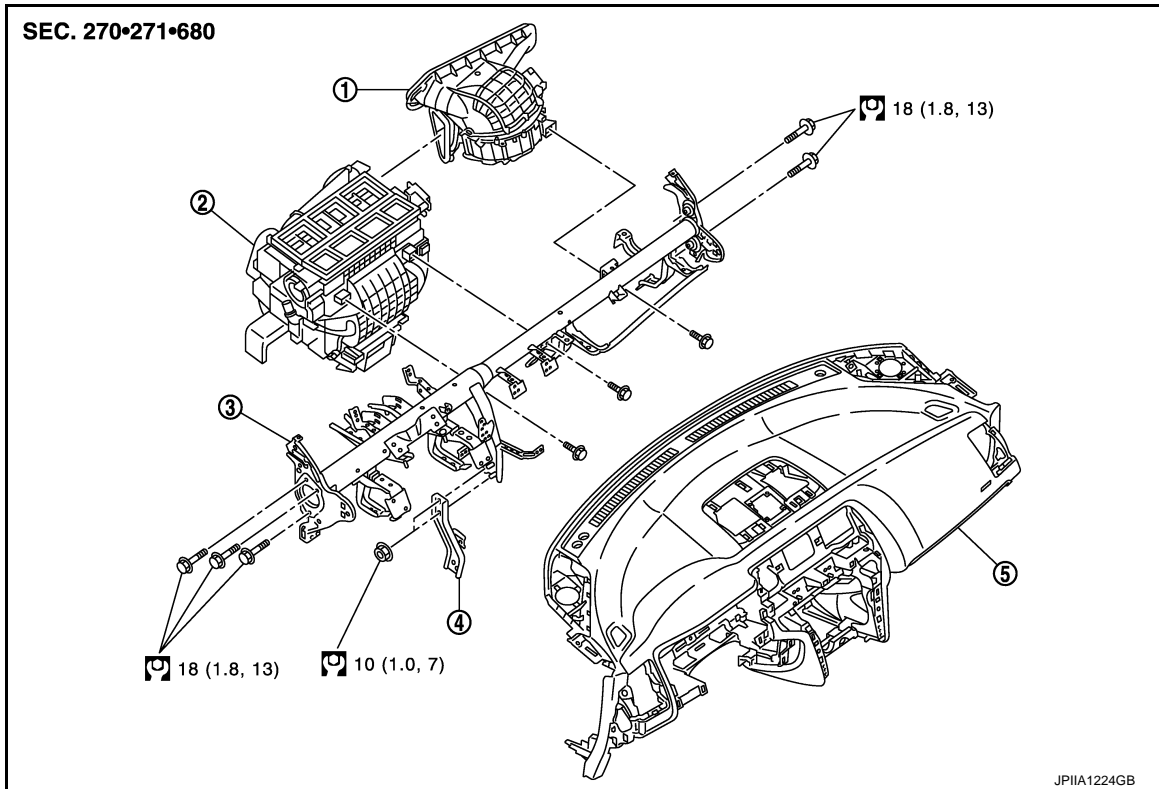

- | | | |
|-------------------------|-----------------------------------|--------------------|
| 1. Blower unit assembly | 2. Heater & cooling unit assembly | 3. Steering member |
| 4. Instrument stay | 5. Instrument panel assembly | |

Refer to [GI-4, "Components"](#) for symbols in the figure.

DISASSEMBLY

BLOWER UNIT

< REMOVAL AND INSTALLATION >

[WITHOUT 7 INCH DISPLAY]

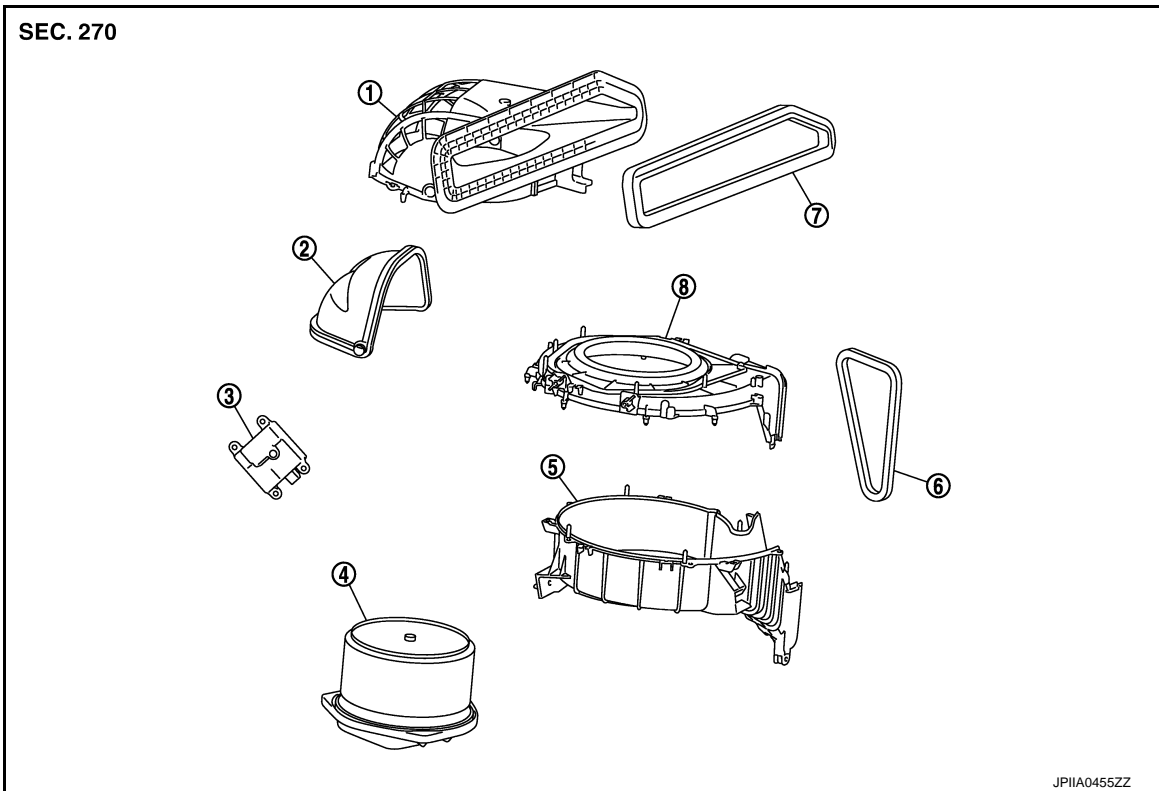

- | | | |
|--------------------------|----------------------|----------------------|
| 1. Shutter box case | 2. Intake door | 3. Intake door motor |
| 4. Blower motor assembly | 5. Intake lower case | 6. Outlet seal |
| 7. Intake seal | 8. Intake upper case | |

Removal and Installation

INFOID:000000006258562

REMOVAL

1. Remove the instrument panel assembly. Refer to [IP-12, "Exploded View"](#).
2. Remove the mounting nuts (A), and then remove the instrument panel stay (1).

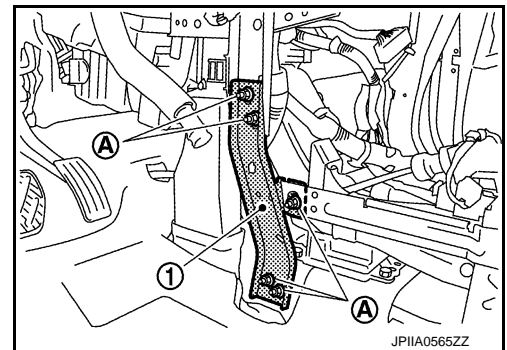

3. Disconnect the intake door motor and blower motor connectors.

BLOWER UNIT

< REMOVAL AND INSTALLATION >

[WITHOUT 7 INCH DISPLAY]

4. Remove the heater & cooling unit assembly and blower unit mounting bolts (A).

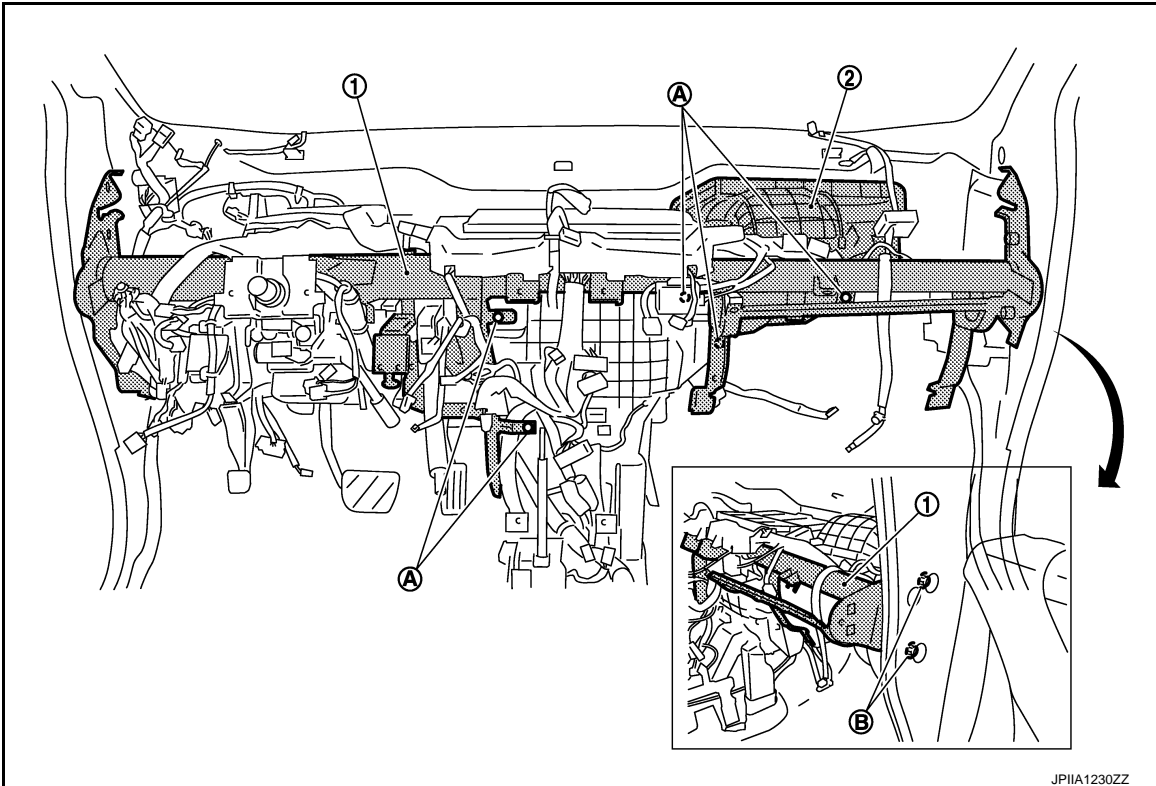

Refer to [GI-4. "Components"](#) for symbols in the figure.

5. Remove the steering member mounting bolts (B) (right).
6. And remove the blower unit (2) while pulling the steering member (1) to the front.

INSTALLATION

Install in the reverse order of removal.

BLOWER MOTOR

< REMOVAL AND INSTALLATION >

[WITHOUT 7 INCH DISPLAY]

BLOWER MOTOR

Exploded View

INFOID:000000006258563

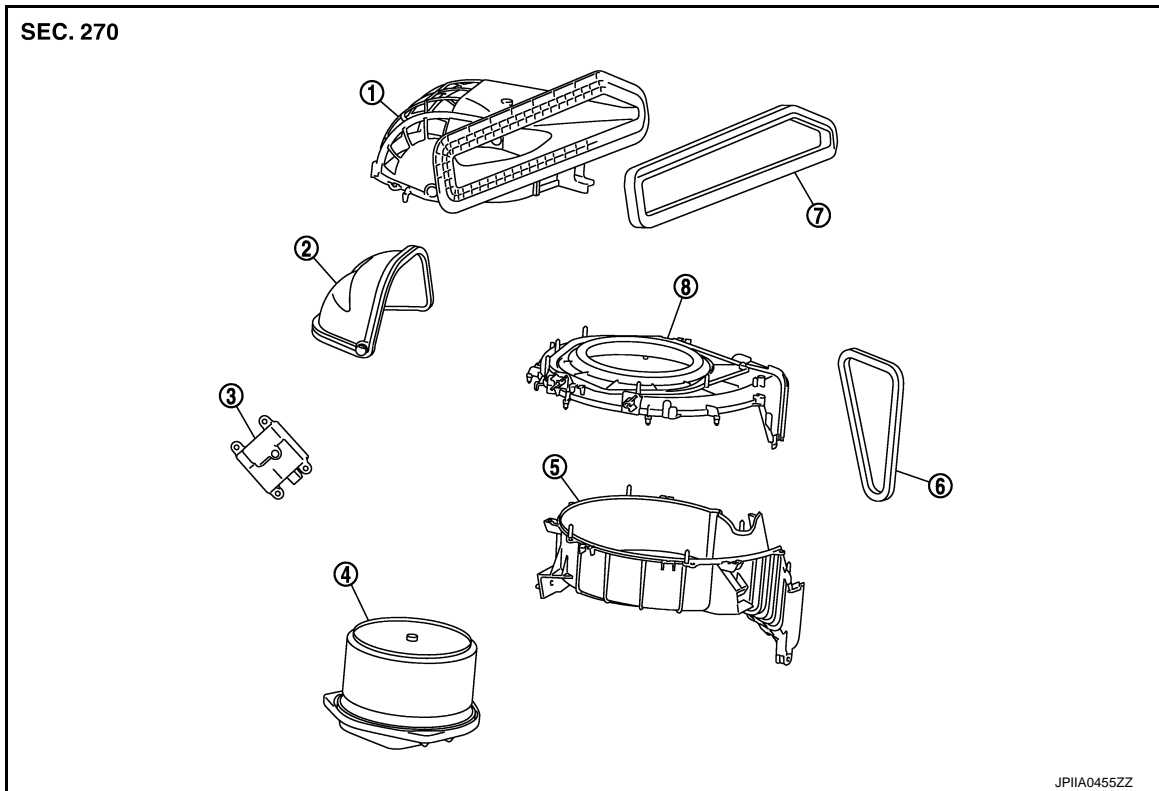

- | | | |
|--------------------------|----------------------|----------------------|
| 1. Shutter box case | 2. Intake door | 3. Intake door motor |
| 4. Blower motor assembly | 5. Intake lower case | 6. Outlet seal |
| 7. Intake seal | 8. Intake upper case | |

Removal and Installation

INFOID:000000006258564

REMOVAL

1. Remove instrument lower panel RH. Refer to [IP-12. "Exploded View"](#).
2. Disconnect the blower motor connector.
3. Remove the mounting screws (A), and then remove the blower motor (1).

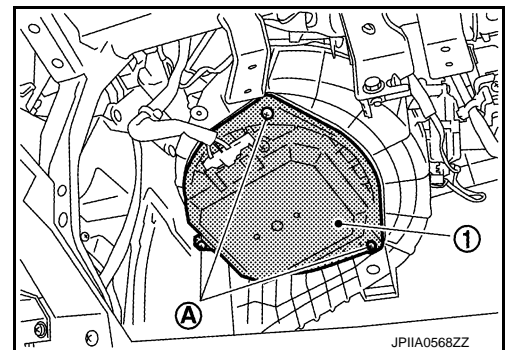

INSTALLATION

Install in the reverse order of removal.

INTAKE DOOR MOTOR

< REMOVAL AND INSTALLATION >

[WITHOUT 7 INCH DISPLAY]

INTAKE DOOR MOTOR

Exploded View

INFOID:000000006258565

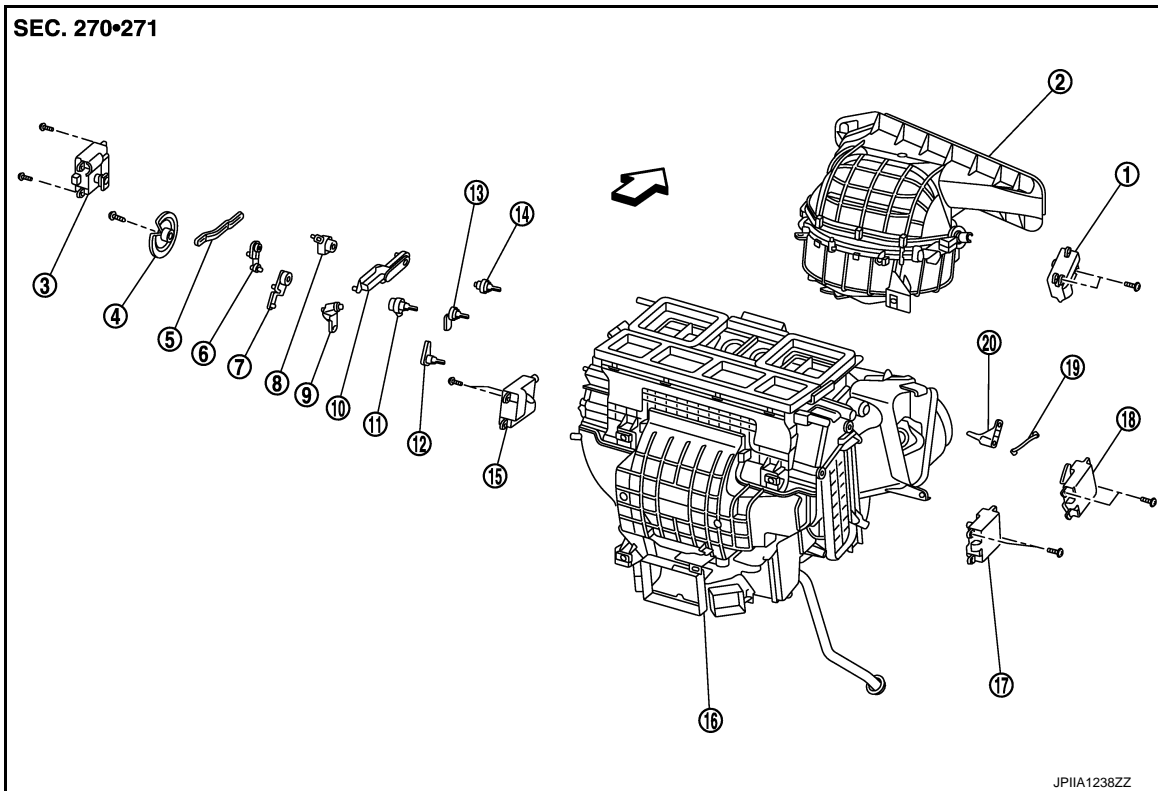

- | | | |
|------------------------------------|---|--------------------------------------|
| 1. Intake door motor | 2. Bower unit assembly | 3. Mode door motor |
| 4. Main link | 5. Rod link | 6. Max. cool door link |
| 7. Max. cool door link | 8. Mode door lever | 9. Ventilator door link |
| 10. Defroster door link | 11. Ventilator door lever | 12. Foot door lever |
| 13. Max. cool door lever | 14. Defroster door lever | 15. Air mix door motor (driver side) |
| 16. Heater & cooling unit assembly | 17. Air mix door motor (passenger side) | 18. Upper ventilator door motor |
| 19. Upper ventilator door rod | 20. Upper ventilator door lever | |

← : Vehicle front

Removal and Installation

INFOID:000000006258566

REMOVAL

1. Remove instrument lower panel RH. Refer to [IP-12, "Exploded View"](#).
2. Remove the mounting screw (A), and then move the key less controller assembly bracket (1) to a position where it does not inhibit work.

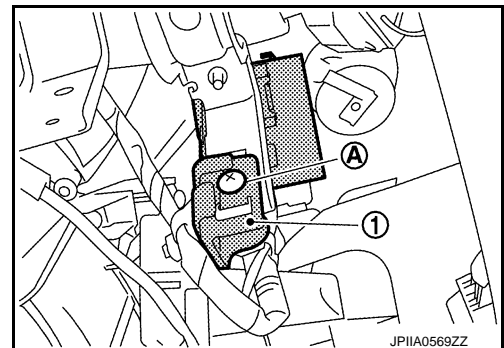

INTAKE DOOR MOTOR

< REMOVAL AND INSTALLATION >

[WITHOUT 7 INCH DISPLAY]

3. Remove the mounting screws (A), and then remove the intake door motor (1).
4. Disconnect the intake door motor connector.

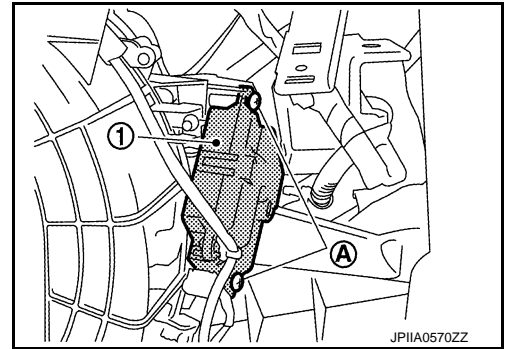

INSTALLATION

Install in the reverse order of removal.

A
B
C
D
E
F
G
H
J
K
L
M
N
O
P

VTL

HEATER & COOLING UNIT ASSEMBLY

< REMOVAL AND INSTALLATION >

[WITHOUT 7 INCH DISPLAY]

HEATER & COOLING UNIT ASSEMBLY

Exploded View

INFOID:000000006258567

REMOVAL

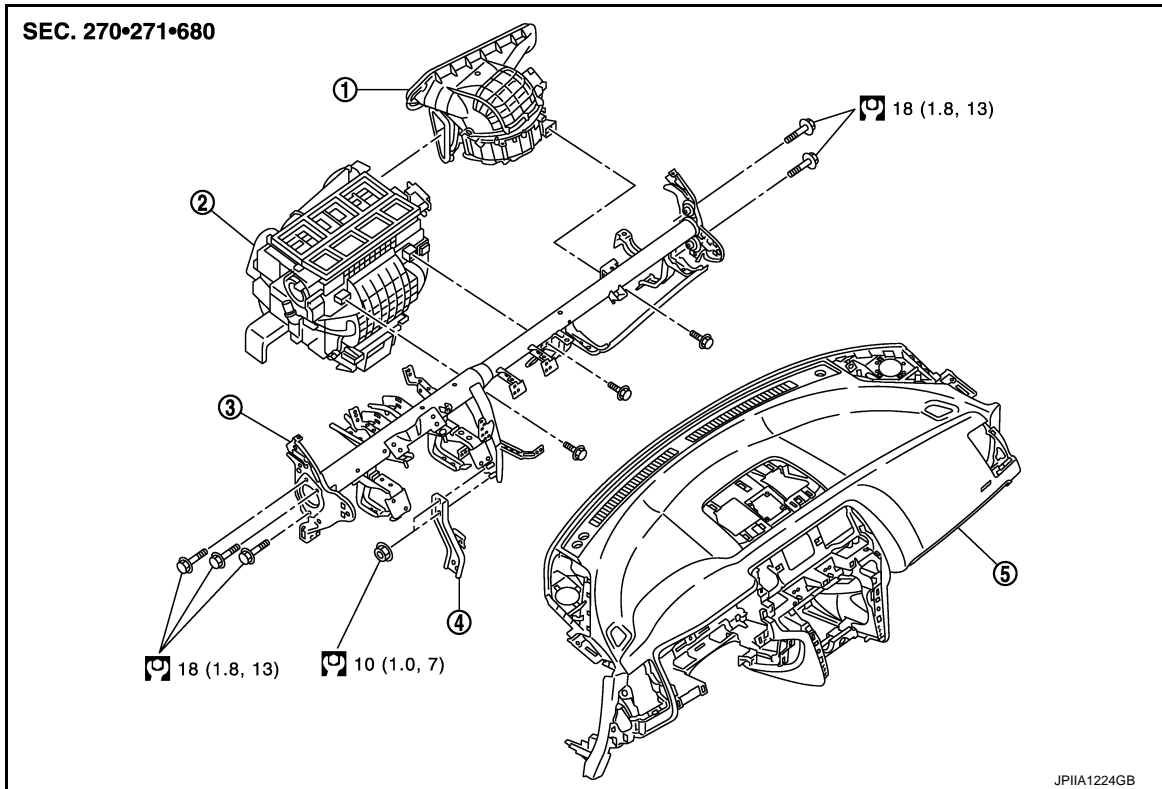

- | | | |
|-------------------------|-----------------------------------|--------------------|
| 1. Blower unit assembly | 2. Heater & cooling unit assembly | 3. Steering member |
| 4. Instrument stay | 5. Instrument panel assembly | |

Refer to [GI-4, "Components"](#) for symbols in the figure.

DISASSEMBLY

HEATER & COOLING UNIT ASSEMBLY

< REMOVAL AND INSTALLATION >

[WITHOUT 7 INCH DISPLAY]

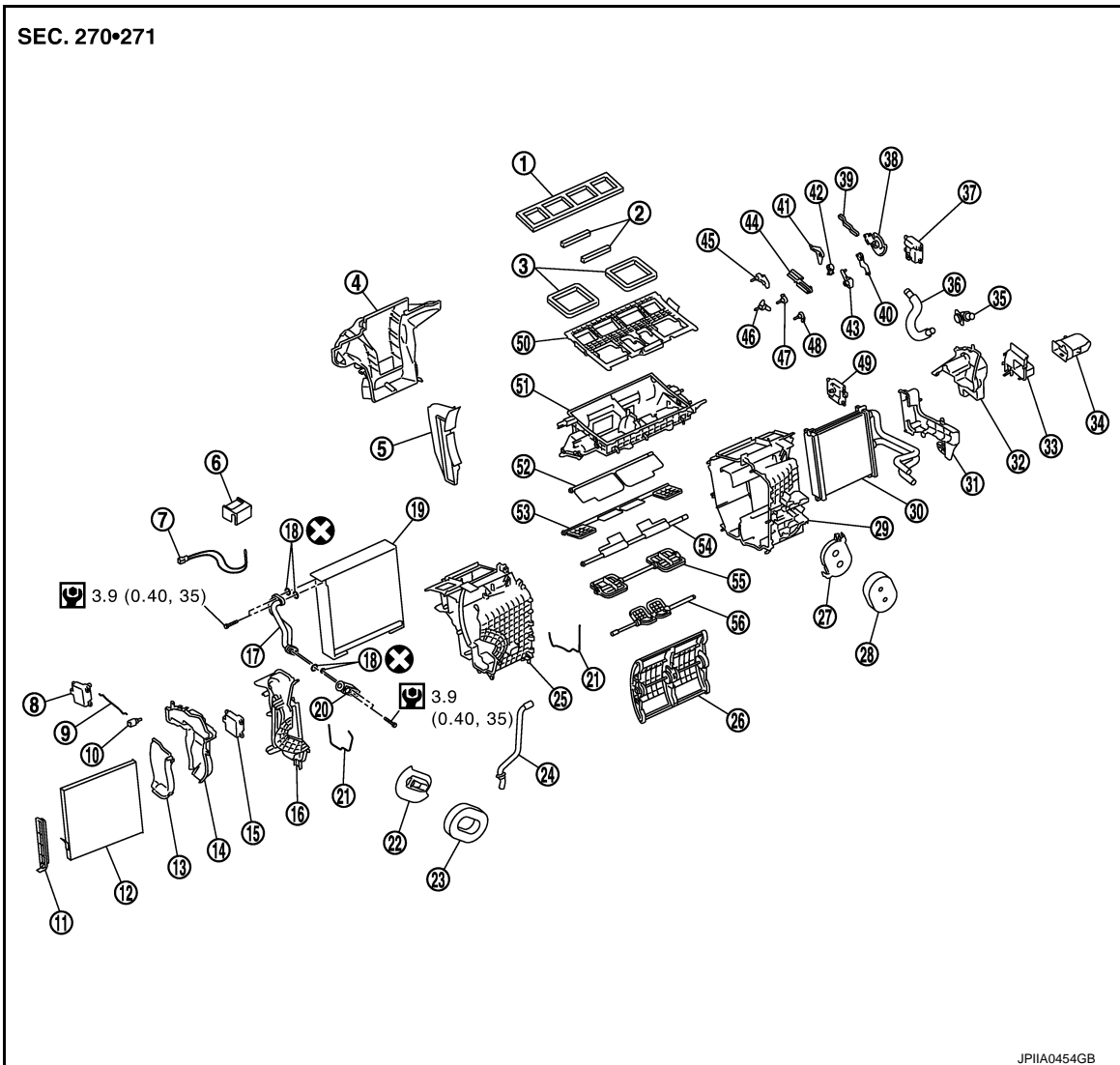

- | | | |
|--|---------------------------------------|--|
| 1. Ventilator seal | 2. Upper ventilator seal | 3. Defroster seal |
| 4. Adapter case | 5. Center case | 6. Intake sensor bracket |
| 7. Intake sensor | 8. Upper ventilator door motor | 9. Upper ventilator door rod |
| 10. Upper ventilator door lever | 11. Filter cover | 12. In-cabin microfilter/Air conditioner filter* |
| 13. Foot duct 1 (right) | 14. Foot duct 2 (right) | 15. Air mix door motor (passenger side) |
| 16. Heater & cooling unit case cover | 17. Evaporator pipe assembly | 18. O-ring |
| 19. Evaporator | 20. Expansion valve | 21. Case packing |
| 22. Grommet | 23. Cooler pipe grommet | 24. Drain hose |
| 25. Heater & cooling unit case (right) | 26. Air mix door (Slide door) | 27. Heater pipe support |
| 28. Heater pipe grommet | 29. Heater & cooling unit case (left) | 30. Heater core |
| 31. Heater pipe cover | 32. Foot duct 2 (left) | 33. Foot duct 1 (left) |
| 34. Heater duct | 35. Aspirator | 36. Aspirator hose |
| 37. Mode door motor | 38. Main link | 39. Rod link |
| 40. Max. cool door link | 41. Ventilator door link | 42. Foot door link |
| 43. Mode door lever | 44. Defroster door link | 45. Ventilator door lever |
| 46. Foot door lever | 47. Defroster door lever | 48. Max. cool door lever |
| 49. Air mix door motor (driver side) | 50. Distributor upper case | 51. Distributor lower case |
| 52. Ventilator door | 53. Foot door | 54. Max. cool door |
| 55. Defroster door | 56. Upper ventilator door | |

A
B
C
D
E
F
G
H
J
K
L
M
N
O
P

VTL

HEATER & COOLING UNIT ASSEMBLY

< REMOVAL AND INSTALLATION >

[WITHOUT 7 INCH DISPLAY]

* : Models for Mexico.

Refer to [GI-4, "Components"](#) for symbols in the figure.

Removal and Installation

INFOID:000000006258568

REMOVAL

1. Collect the refrigerant with refrigerant collecting equipment (for HFC134a).
2. Drain engine coolant. Refer to [CO-11, "Draining"](#).
3. Remove the mounting bolt (A), and then disconnect the low-pressure pipe (1) and high-pressure pipe (2) from the expansion valve.

CAUTION:

Cap or wrap the joint of the A/C piping and expansion valve with suitable material such as vinyl tape to avoid the entry of air.

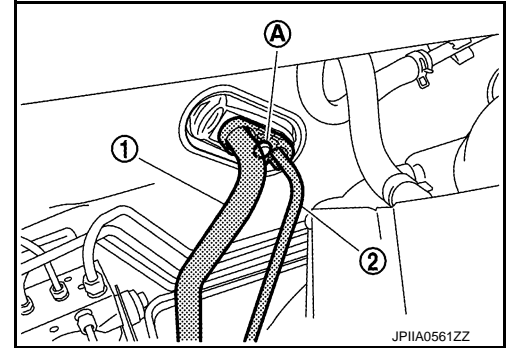

4. Remove the clamps (A), and then disconnect the heater hoses (1).

CAUTION:

- Some coolant may spill when heater hoses are disconnected. Wipe them off with wastes.
- Close the coolant inlet/outlet on the heater core and heater hoses with wastes.

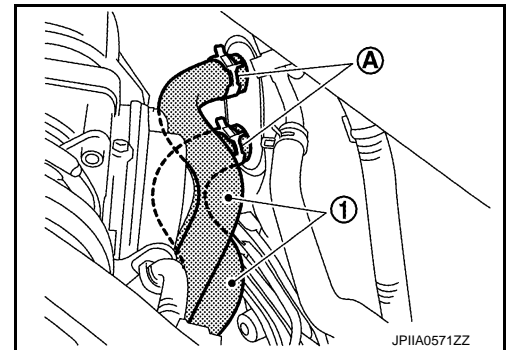

5. Remove the instrument panel assembly. Refer to [IP-12, "Exploded View"](#).
6. Remove the mounting nuts (A), and then remove the instrument stay (1).

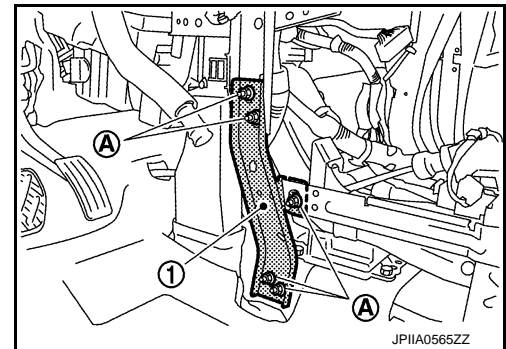

HEATER & COOLING UNIT ASSEMBLY

< REMOVAL AND INSTALLATION >

[WITHOUT 7 INCH DISPLAY]

7. Remove the heater & cooling unit assembly and blower unit mounting bolts (A).

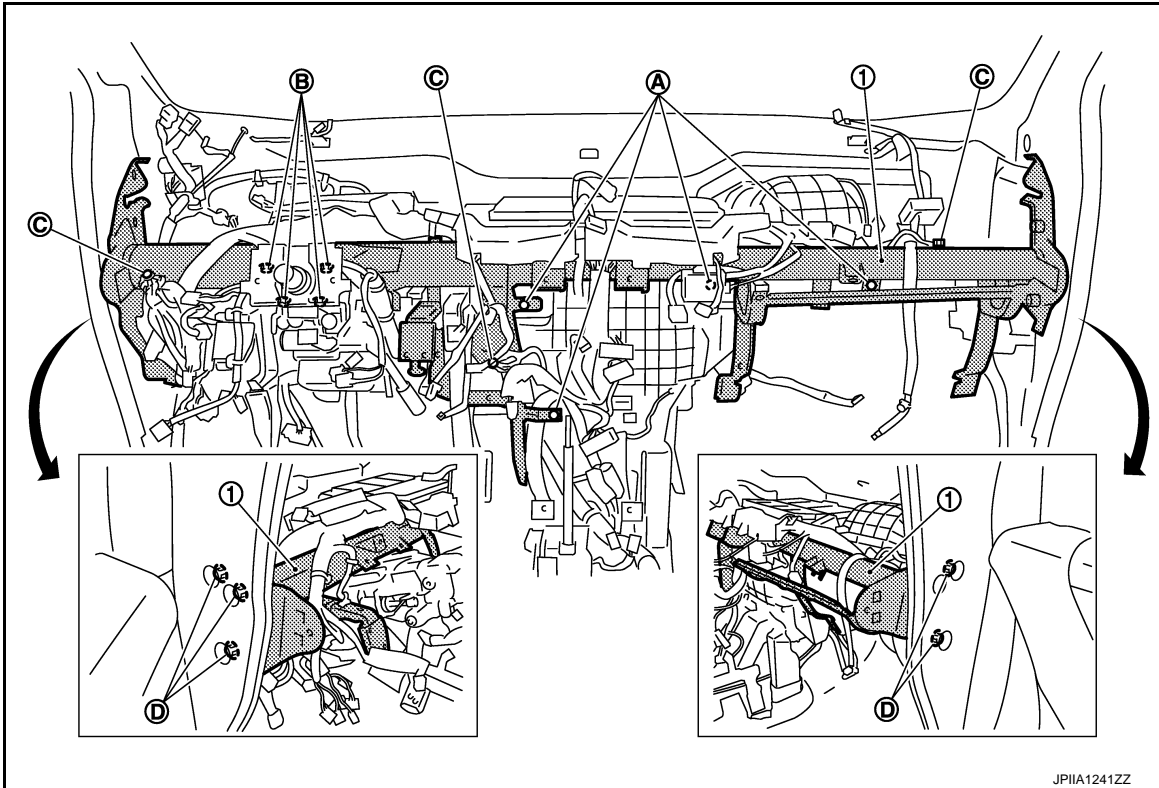

Refer to [GI-4, "Components"](#) for symbols shown in the figure.

8. Remove the steering column mounting nuts (B). Refer to [ST-35, "WITHOUT ELECTRIC MOTOR : Exploded View"](#) (without electric motor) or [ST-38, "WITH ELECTRIC MOTOR : Exploded View"](#) (with electric motor).
9. Remove the ground bolts (C) from the steering member (1).
10. Remove the harness clip from the steering member.
11. Disconnect the intake door motor and blower motor connectors.
12. Remove the steering member mounting bolts (D), and then remove the steering member.
13. Remove the mounting screw (A), and then remove the blower unit (1).

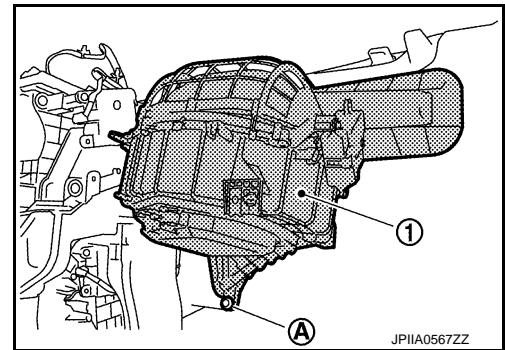

14. Disconnect the drain hose (1) from heater & cooling unit assembly.

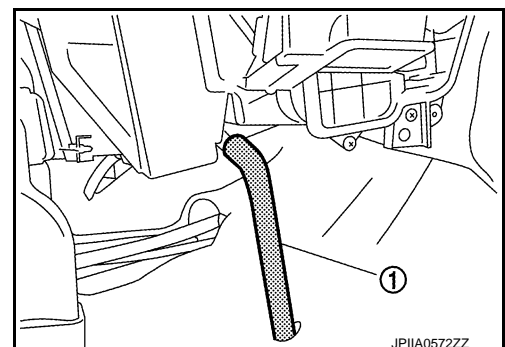

A
B
C
D
E
F
G
H

VTL

J
K
L
M
N
O
P

HEATER & COOLING UNIT ASSEMBLY

< REMOVAL AND INSTALLATION >

[WITHOUT 7 INCH DISPLAY]

15. Remove the rear foot duct 1 (left/right) (A) and rear ventilator duct 1 (B), and then remove the heater & cooling unit assembly (1).

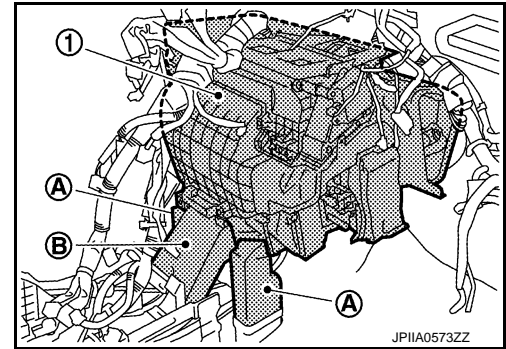

INSTALLATION

Install in the reverse order of removal.

CAUTION:

- Replace the O-ring with a new one. Apply a coat of compressor oil to the O-ring prior to installation.
- Check for refrigerant leakage when charging refrigerant.

NOTE:

- Refer to [CO-12, "Refilling"](#) when filling the radiator with engine coolant.
- Charge the refrigerant again.

UPPER VENTILATOR DOOR MOTOR

< REMOVAL AND INSTALLATION >

[WITHOUT 7 INCH DISPLAY]

UPPER VENTILATOR DOOR MOTOR

Exploded View

INFOID:000000006258569

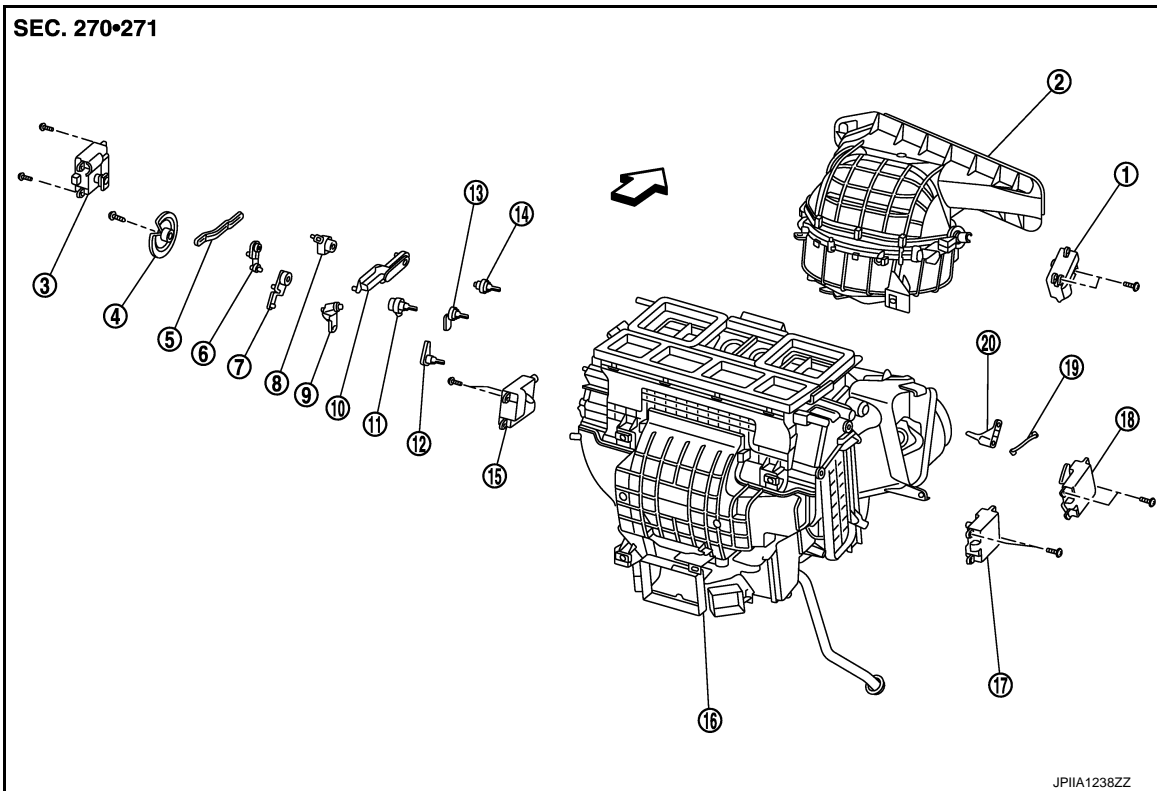

- | | | |
|------------------------------------|---|--------------------------------------|
| 1. Intake door motor | 2. Bower unit assembly | 3. Mode door motor |
| 4. Main link | 5. Rod link | 6. Max. cool door link |
| 7. Max. cool door link | 8. Mode door lever | 9. Ventilator door link |
| 10. Defroster door link | 11. Ventilator door lever | 12. Foot door lever |
| 13. Max. cool door lever | 14. Defroster door lever | 15. Air mix door motor (driver side) |
| 16. Heater & cooling unit assembly | 17. Air mix door motor (passenger side) | 18. Upper ventilator door motor |
| 19. Upper ventilator door rod | 20. Upper ventilator door lever | |

↔ : Vehicle front

Removal and Installation

INFOID:000000006258570

REMOVAL

1. Remove the blower unit. Refer to [VTL-30, "Exploded View"](#).
2. Remove the mounting screws (A), and then remove the upper ventilator door motor (1).
3. Disconnect the upper ventilator door motor connector.

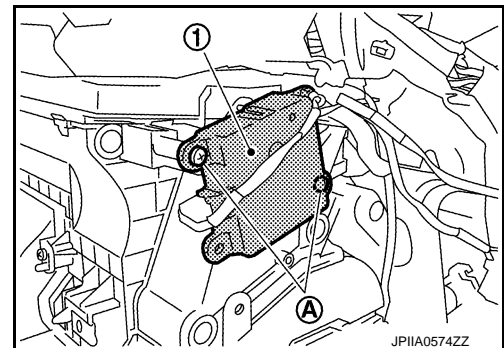

INSTALLATION

Install in the reverse order of removal.

MODE DOOR MOTOR

< REMOVAL AND INSTALLATION >

[WITHOUT 7 INCH DISPLAY]

MODE DOOR MOTOR

Exploded View

INFOID:000000006258571

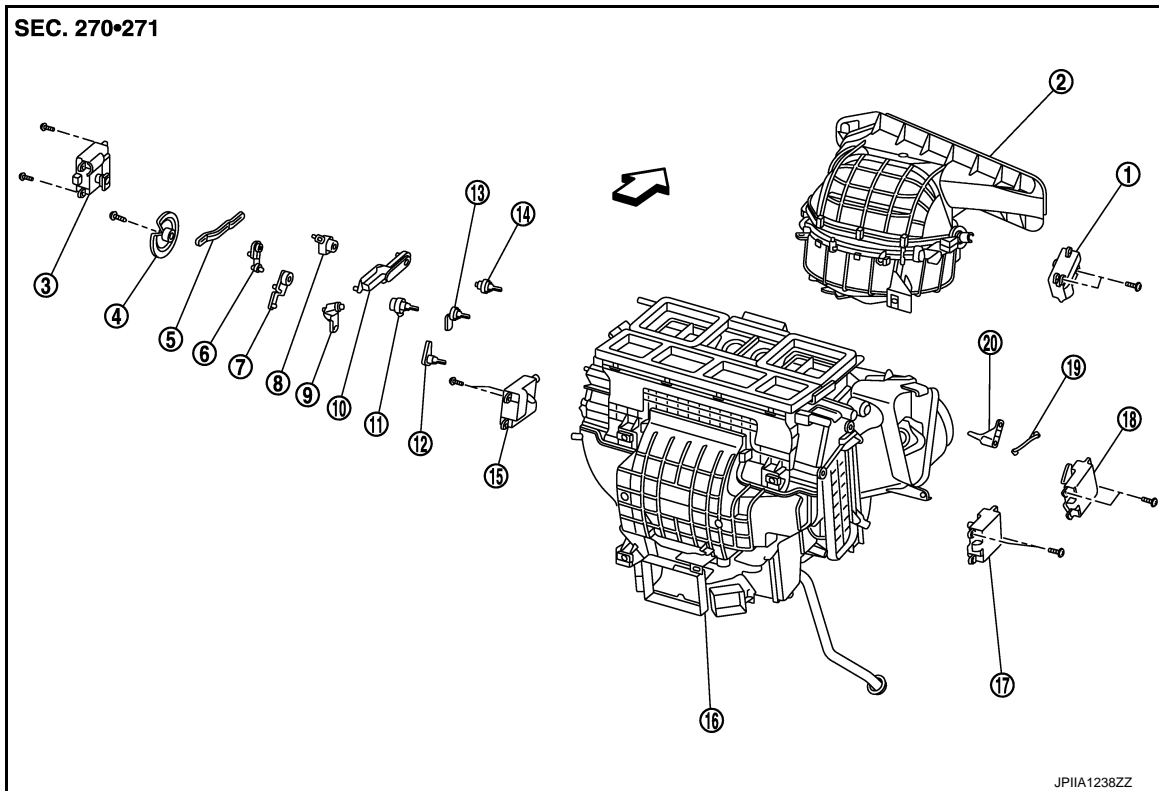

- | | | |
|------------------------------------|---|--------------------------------------|
| 1. Intake door motor | 2. Bower unit assembly | 3. Mode door motor |
| 4. Main link | 5. Rod link | 6. Max. cool door link |
| 7. Max. cool door link | 8. Mode door lever | 9. Ventilator door link |
| 10. Defroster door link | 11. Ventilator door lever | 12. Foot door lever |
| 13. Max. cool door lever | 14. Defroster door lever | 15. Air mix door motor (driver side) |
| 16. Heater & cooling unit assembly | 17. Air mix door motor (passenger side) | 18. Upper ventilator door motor |
| 19. Upper ventilator door rod | 20. Upper ventilator door lever | |

← : Vehicle front

Removal and Installation

INFOID:000000006258572

REMOVAL

1. Remove the instrument panel assembly. Refer to [IP-12, "Exploded View"](#).
2. Remove the mounting screws (A), and then remove the mode door motor (1).
3. Disconnect the mode door motor connector.

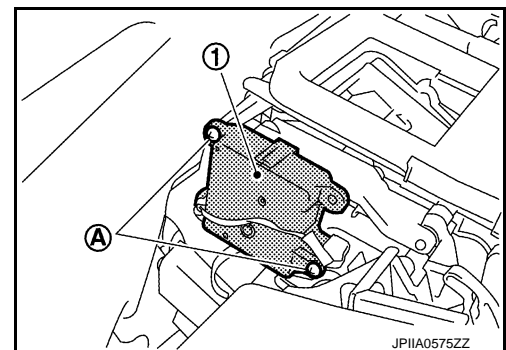

INSTALLATION

Install in the reverse order of removal.

AIR MIX DOOR MOTOR

< REMOVAL AND INSTALLATION >

[WITHOUT 7 INCH DISPLAY]

AIR MIX DOOR MOTOR

Exploded View

INFOID:000000006258573

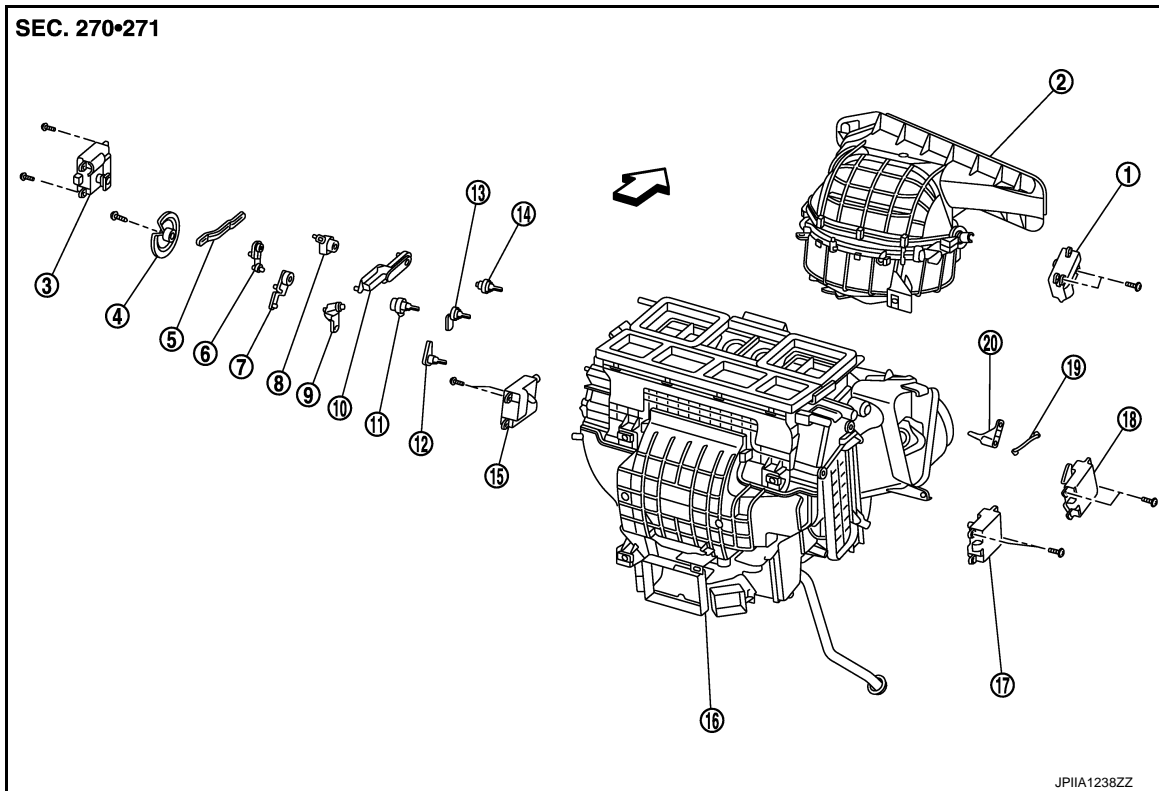

- | | | |
|------------------------------------|---|--------------------------------------|
| 1. Intake door motor | 2. Bower unit assembly | 3. Mode door motor |
| 4. Main link | 5. Rod link | 6. Max. cool door link |
| 7. Max. cool door link | 8. Mode door lever | 9. Ventilator door link |
| 10. Defroster door link | 11. Ventilator door lever | 12. Foot door lever |
| 13. Max. cool door lever | 14. Defroster door lever | 15. Air mix door motor (driver side) |
| 16. Heater & cooling unit assembly | 17. Air mix door motor (passenger side) | 18. Upper ventilator door motor |
| 19. Upper ventilator door rod | 20. Upper ventilator door lever | |

↶ : Vehicle front

Removal and Installation

INFOID:000000006258574

REMOVAL

Driver side

1. Set the temperature (driver side) at 18°C (60°F).

CAUTION:

The angle may be out, when installing the air mix door motor to the air mix door, unless the above procedure is performed.

2. Disconnect the battery cable from the negative terminal.
3. Remove the foot duct (left). Refer to [VTL-67. "FOOT DUCT : Exploded View"](#).

AIR MIX DOOR MOTOR

< REMOVAL AND INSTALLATION >

[WITHOUT 7 INCH DISPLAY]

4. Remove the mounting screws (A), and then remove the air mix door motor (1).
5. Disconnect the air mix door motor connector.

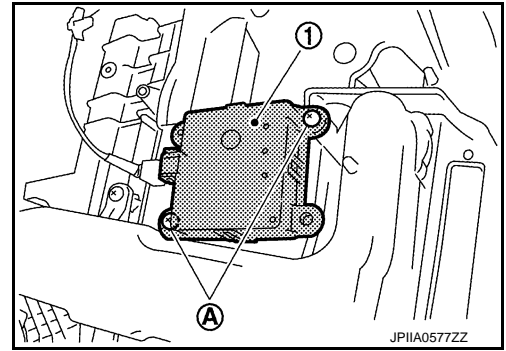

Passenger side

1. Set the temperature (passenger side) at 18°C (60°F).

CAUTION:

The angle may be out, when installing the air mix door motor to the air mix door, unless the above procedure is performed.

2. Disconnect the battery cable from the negative terminal.
3. Remove the foot duct (right). Refer to [VTL-67. "FOOT DUCT : Exploded View"](#).
4. Remove the mounting screws (A), and then remove the air mix door motor (1).
5. Disconnect the air mix door motor connector.

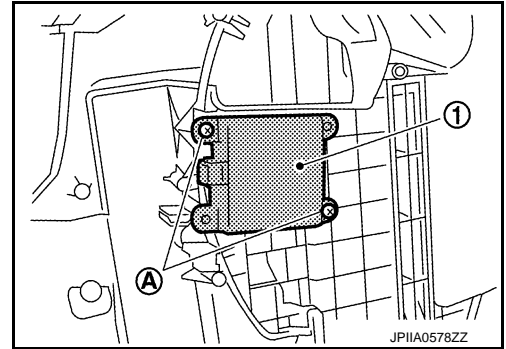

INSTALLATION

Install in the reverse order of removal.

HEATER CORE

< REMOVAL AND INSTALLATION >

[WITHOUT 7 INCH DISPLAY]

HEATER CORE

Exploded View

INFOID:000000006258575

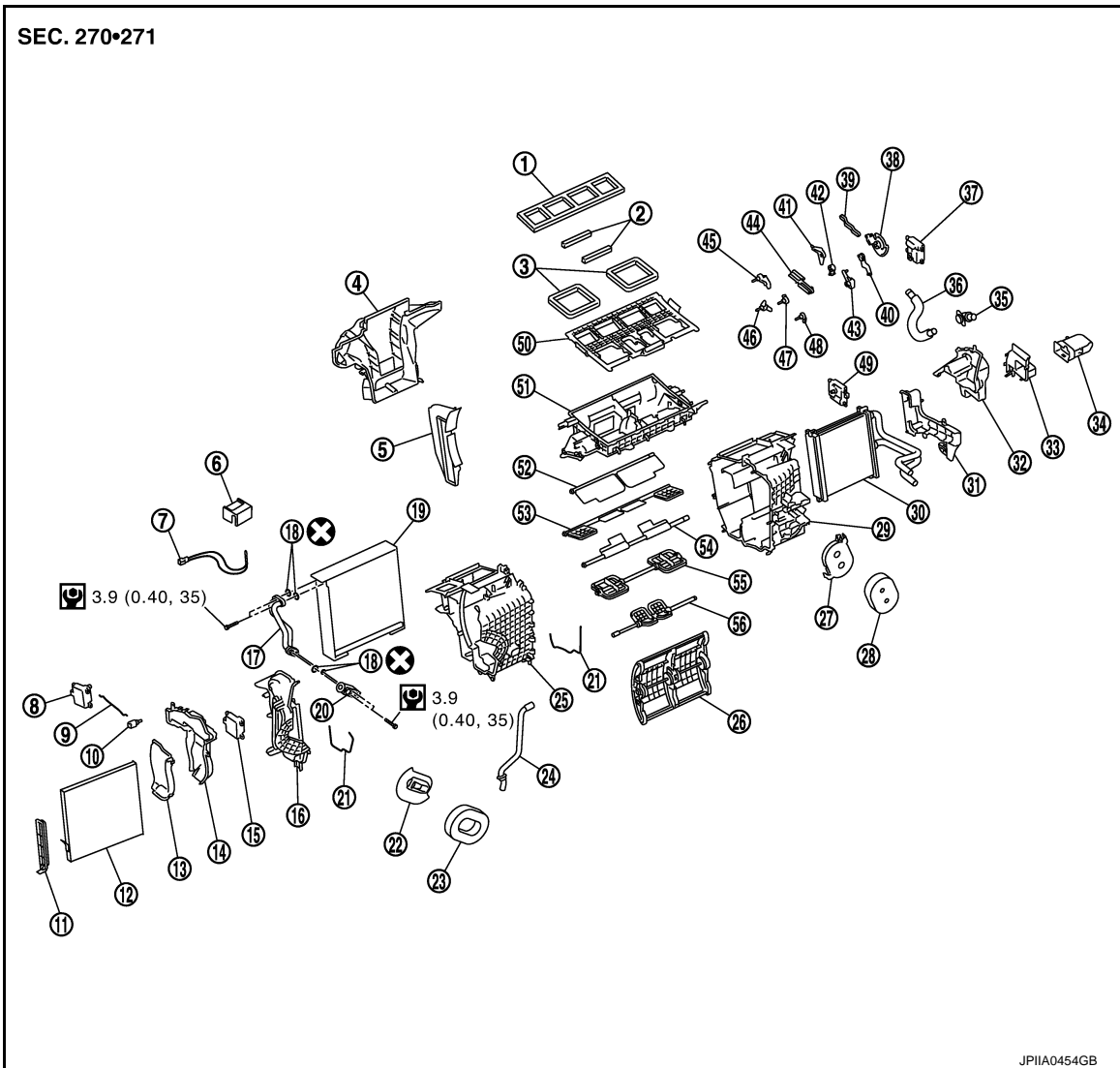

- | | | |
|--|---------------------------------------|--|
| 1. Ventilator seal | 2. Upper ventilator seal | 3. Defroster seal |
| 4. Adapter case | 5. Center case | 6. Intake sensor bracket |
| 7. Intake sensor | 8. Upper ventilator door motor | 9. Upper ventilator door rod |
| 10. Upper ventilator door lever | 11. Filter cover | 12. In-cabin microfilter/Air conditioner filter* |
| 13. Foot duct 1 (right) | 14. Foot duct 2 (right) | 15. Air mix door motor (passenger side) |
| 16. Heater & cooling unit case cover | 17. Evaporator pipe assembly | 18. O-ring |
| 19. Evaporator | 20. Expansion valve | 21. Case packing |
| 22. Grommet | 23. Cooler pipe grommet | 24. Drain hose |
| 25. Heater & cooling unit case (right) | 26. Air mix door (Slide door) | 27. Heater pipe support |
| 28. Heater pipe grommet | 29. Heater & cooling unit case (left) | 30. Heater core |
| 31. Heater pipe cover | 32. Foot duct 2 (left) | 33. Foot duct 1 (left) |
| 34. Heater duct | 35. Aspirator | 36. Aspirator hose |
| 37. Mode door motor | 38. Main link | 39. Rod link |
| 40. Max. cool door link | 41. Ventilator door link | 42. Foot door link |
| 43. Mode door lever | 44. Defroster door link | 45. Ventilator door lever |

HEATER CORE

< REMOVAL AND INSTALLATION >

[WITHOUT 7 INCH DISPLAY]

- | | | |
|--------------------------------------|----------------------------|----------------------------|
| 46. Foot door lever | 47. Defroster door lever | 48. Max. cool door lever |
| 49. Air mix door motor (driver side) | 50. Distributor upper case | 51. Distributor lower case |
| 52. Ventilator door | 53. Foot door | 54. Max. cool door |
| 55. Defroster door | 56. Upper ventilator door | |
- * : Models for Mexico.

Refer to [GI-4. "Components"](#) for symbols in the figure.

Removal and Installation

INFOID:000000006258576

REMOVAL

1. Remove the heater & cooling unit assembly. Refer to [VTL-36. "Exploded View"](#).
2. Remove the mounting screws (A), and then remove the foot duct (left) (1).

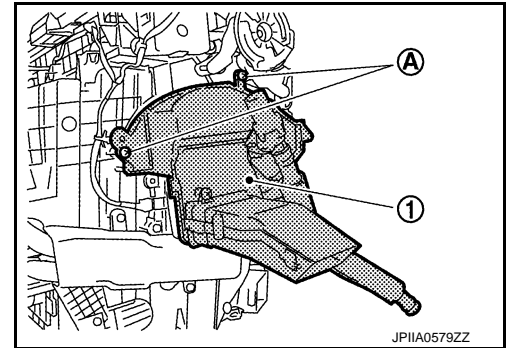

3. Remove the heater pipe grommet (1).
4. Remove the mounting screw (A), and then remove the heater pipe support (2).
5. Remove the mounting screws (B), and then remove the heater pipe cover (3).

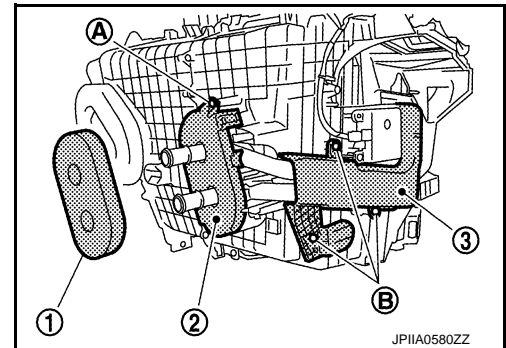

6. Slide the heater core (1) in the direction shown by the arrow, and then remove it.

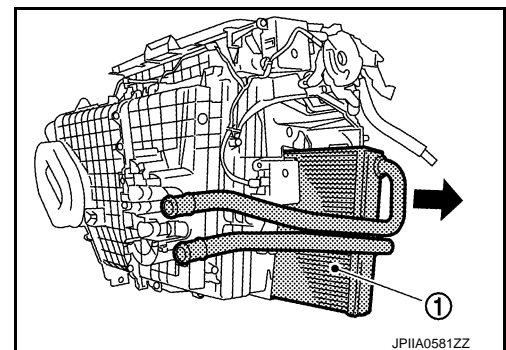

INSTALLATION

Install in the reverse order of removal.

CAUTION:

- Replace the O-ring with a new one. Apply a coat of compressor oil to the O-ring prior to installation.
- Check for refrigerant leakage when charging refrigerant.

NOTE:

- Refer to [CO-12. "Refilling"](#) when filling the radiator with engine coolant.
- Charge the refrigerant again.

DUCT AND GRILLE

< REMOVAL AND INSTALLATION >

[WITHOUT 7 INCH DISPLAY]

DUCT AND GRILLE CENTER VENTILATOR GRILLE

CENTER VENTILATOR GRILLE : Exploded View

INFOID:000000006258577

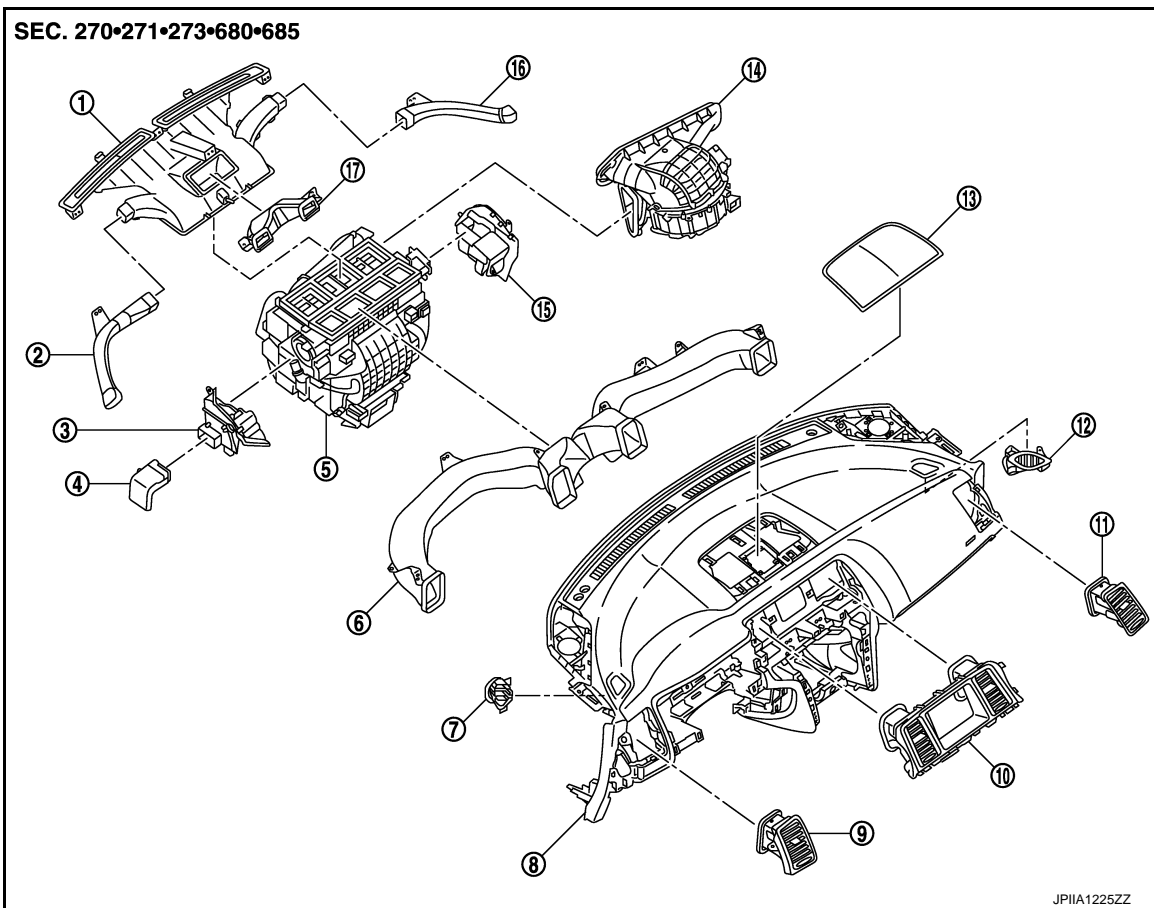

- | | | |
|---------------------------------------|------------------------------------|-----------------------------------|
| 1. Defroster nozzle | 2. Side defroster nozzle (left) | 3. Foot duct (left) |
| 4. Heater duct | 5. Heater & cooling unit assembly | 6. Ventilator duct |
| 7. Side defroster grille (left) | 8. Instrument panel assembly | 9. Side ventilator grille (left) |
| 10. Center ventilator grille assembly | 11. Side ventilator grille (right) | 12. Side defroster grille (right) |
| 13. Center speaker grille | 14. Blower unit assembly | 15. Foot duct (right) |
| 16. Side defroster nozzle (right) | 17. Upper ventilator duct | |

CENTER VENTILATOR GRILLE : Removal and Installation

INFOID:000000006258578

REMOVAL

1. Remove the cluster lid A. Refer to [IP-12, "Exploded View"](#).
2. Remove the cluster lid D. Refer to [IP-12, "Exploded View"](#).

DUCT AND GRILLE

< REMOVAL AND INSTALLATION >

[WITHOUT 7 INCH DISPLAY]

- Remove the mounting screws (A), and then remove the center ventilator grille assembly (1).

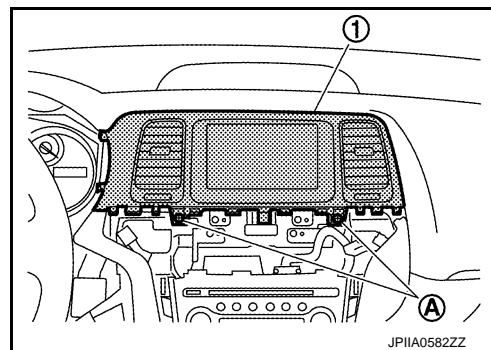

INSTALLATION

Install in the reverse order of removal.

SIDE VENTILATOR GRILLE

SIDE VENTILATOR GRILLE : Exploded View

INFOID:000000006258579

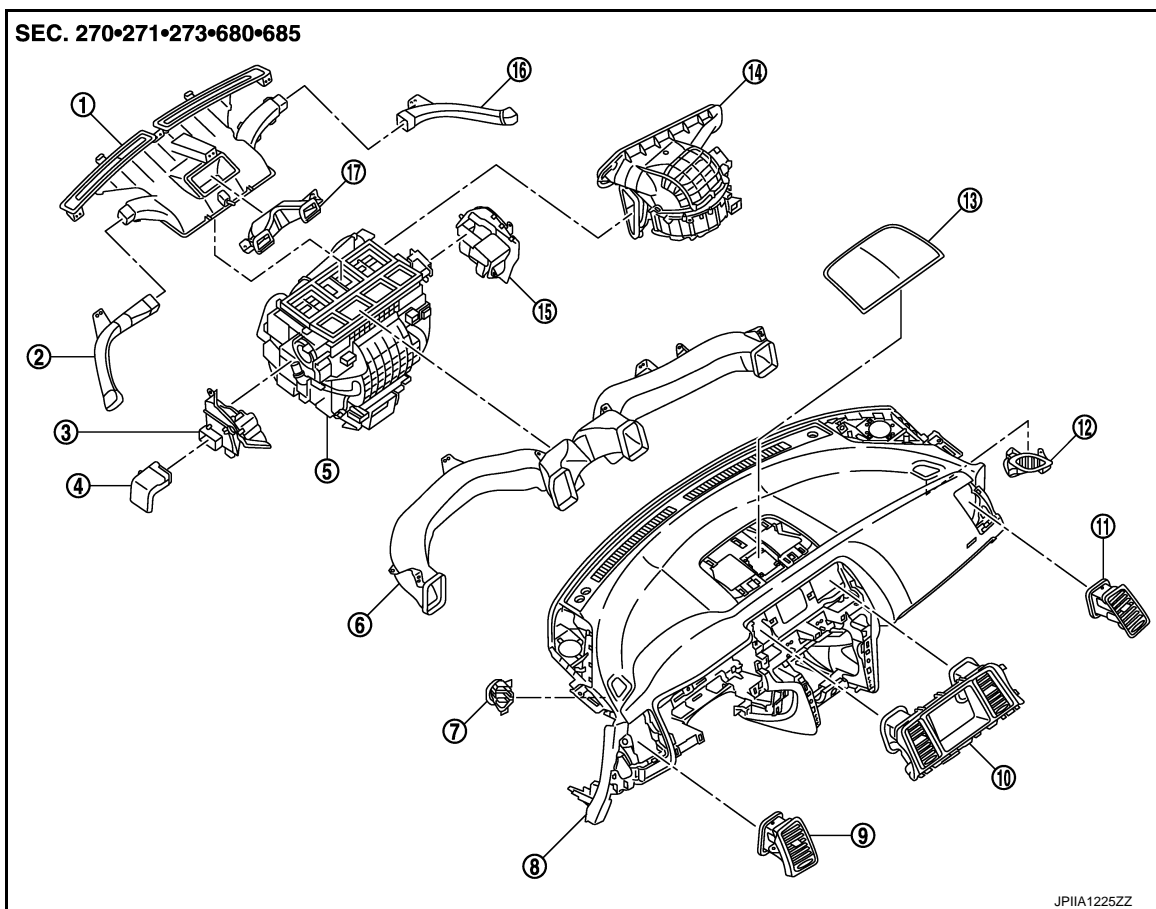

- | | | |
|---------------------------------------|------------------------------------|-----------------------------------|
| 1. Defroster nozzle | 2. Side defroster nozzle (left) | 3. Foot duct (left) |
| 4. Heater duct | 5. Heater & cooling unit assembly | 6. Ventilator duct |
| 7. Side defroster grille (left) | 8. Instrument panel assembly | 9. Side ventilator grille (left) |
| 10. Center ventilator grille assembly | 11. Side ventilator grille (right) | 12. Side defroster grille (right) |
| 13. Center speaker grille | 14. Blower unit assembly | 15. Foot duct (right) |
| 16. Side defroster nozzle (right) | 17. Upper ventilator duct | |

SIDE VENTILATOR GRILLE : Removal and Installation

INFOID:000000006258580

REMOVAL

DUCT AND GRILLE

< REMOVAL AND INSTALLATION >

[WITHOUT 7 INCH DISPLAY]

1. Remove the instrument side finisher (LH/RH). Refer to [JP-12, "Exploded View"](#).
2. Remove the mounting screw (A).
3. Remove side ventilator grille metal clip using remover tool (B), and then remove side ventilator grille (1).

 : Metal clip

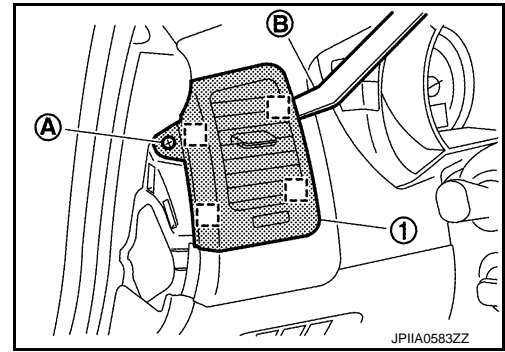

INSTALLATION

Install in the reverse order of removal.

SIDE DEFROSTER GRILLE

SIDE DEFROSTER GRILLE : Exploded View

INFOID:000000006258581

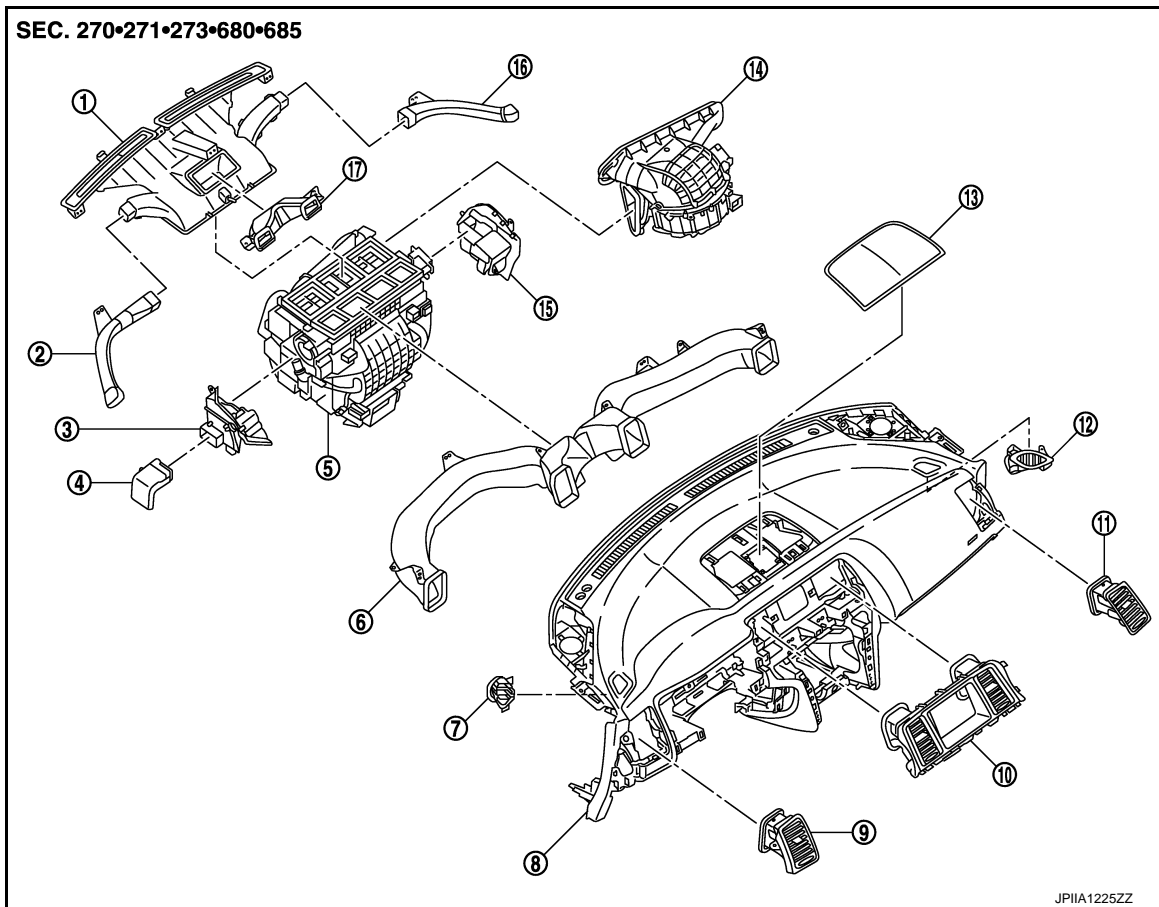

- | | | |
|---------------------------------------|------------------------------------|-----------------------------------|
| 1. Defroster nozzle | 2. Side defroster nozzle (left) | 3. Foot duct (left) |
| 4. Heater duct | 5. Heater & cooling unit assembly | 6. Ventilator duct |
| 7. Side defroster grille (left) | 8. Instrument panel assembly | 9. Side ventilator grille (left) |
| 10. Center ventilator grille assembly | 11. Side ventilator grille (right) | 12. Side defroster grille (right) |
| 13. Center speaker grille | 14. Blower unit assembly | 15. Foot duct (right) |
| 16. Side defroster nozzle (right) | 17. Upper ventilator duct | |

DUCT AND GRILLE

< REMOVAL AND INSTALLATION >

[WITHOUT 7 INCH DISPLAY]

SIDE DEFROSTER GRILLE : Removal and Installation

INFOID:000000006258582

REMOVAL

1. Remove the defroster nozzle and side defroster nozzle. Refer to [VTL-53. "DEFROSTER NOZZLE AND SIDE DEFROSTER NOZZLE : Exploded View"](#).
2. Remove the mounting screws (A), and then remove the side defroster grilles (left/right) (1).

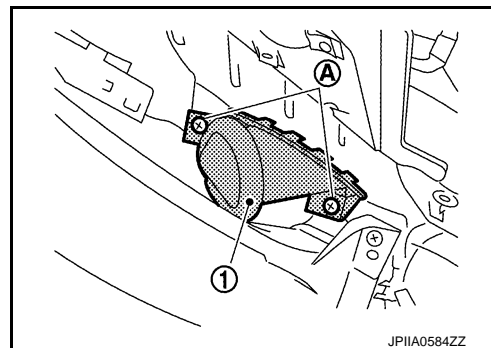

INSTALLATION

Install in the reverse order of removal.

VENTILATOR DUCT

VENTILATOR DUCT : Exploded View

INFOID:000000006258583

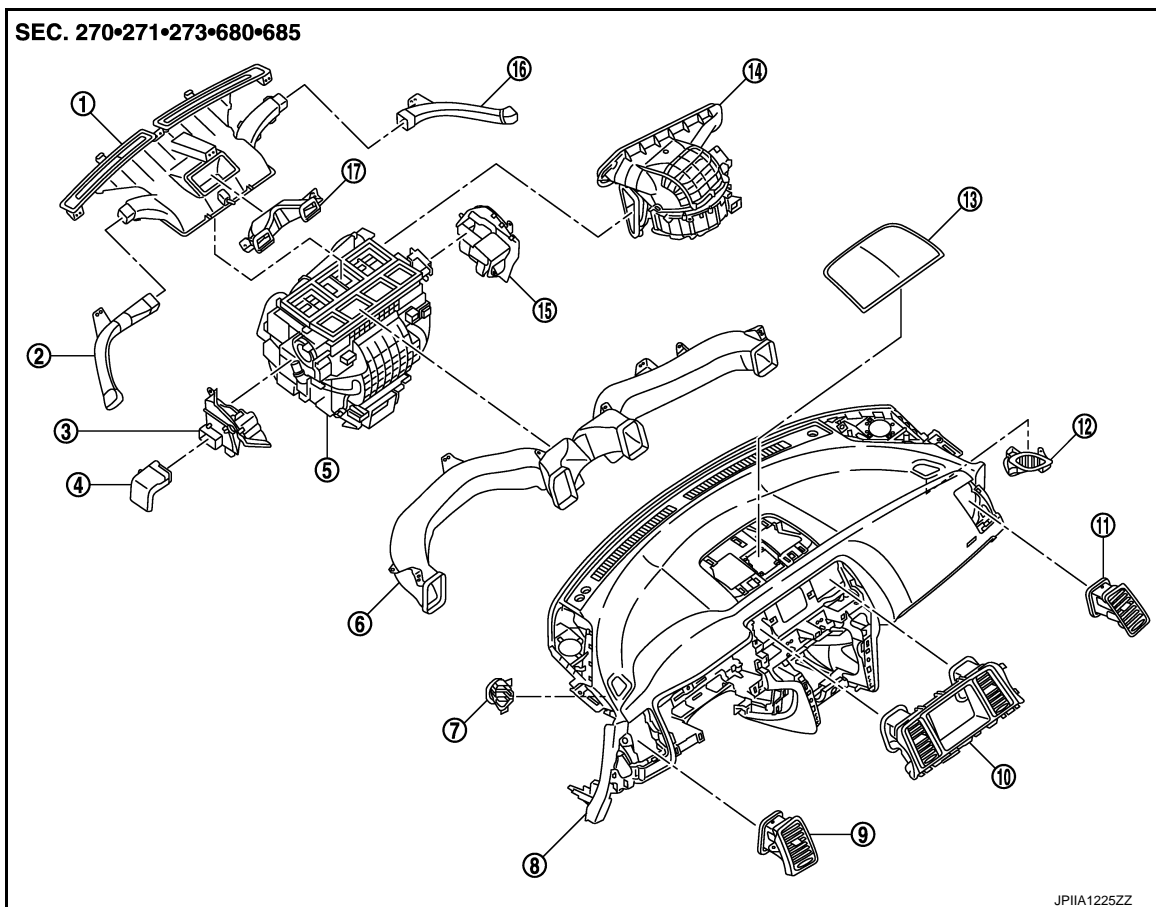

- | | | |
|---------------------------------------|------------------------------------|-----------------------------------|
| 1. Defroster nozzle | 2. Side defroster nozzle (left) | 3. Foot duct (left) |
| 4. Heater duct | 5. Heater & cooling unit assembly | 6. Ventilator duct |
| 7. Side defroster grille (left) | 8. Instrument panel assembly | 9. Side ventilator grille (left) |
| 10. Center ventilator grille assembly | 11. Side ventilator grille (right) | 12. Side defroster grille (right) |

DUCT AND GRILLE

< REMOVAL AND INSTALLATION >

[WITHOUT 7 INCH DISPLAY]

- | | | |
|-----------------------------------|---------------------------|-----------------------|
| 13. Center speaker grille | 14. Blower unit assembly | 15. Foot duct (right) |
| 16. Side defroster nozzle (right) | 17. Upper ventilator duct | |

VENTILATOR DUCT : Removal and Installation

INFOID:000000006258584

REMOVAL

1. Remove the defroster nozzle and side defroster nozzle. Refer to [VTL-53, "DEFROSTER NOZZLE AND SIDE DEFROSTER NOZZLE : Exploded View"](#).
2. Remove the mounting screws (A), and then remove the ventilator duct (1).

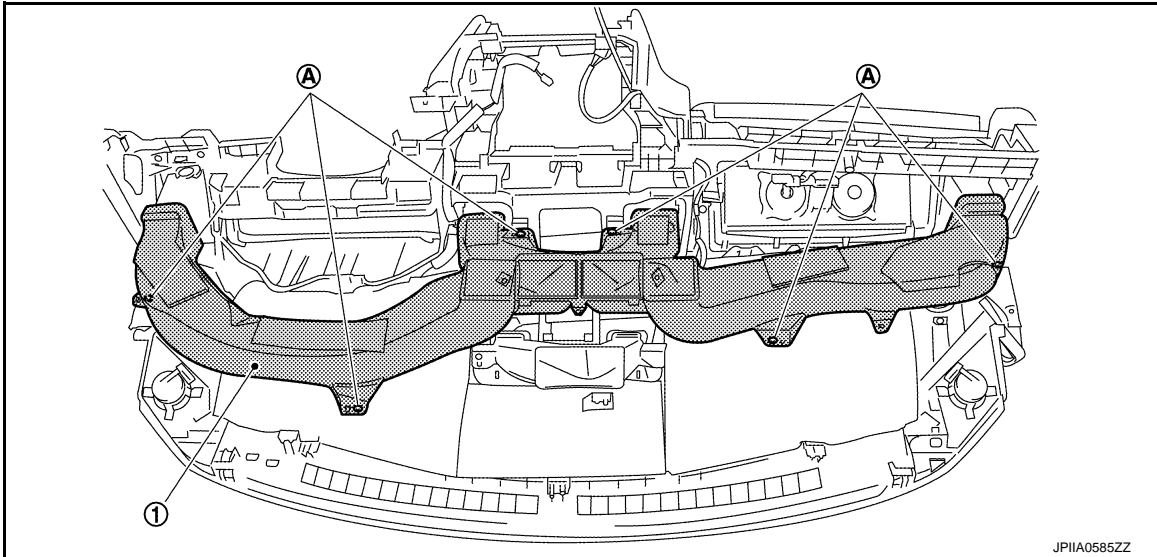

INSTALLATION

Install in the reverse order of removal.

UPPER VENTILATOR DUCT

A
B
C
D
E
F
G
H
J
K
L
M
N
O
P

VTL

DUCT AND GRILLE

< REMOVAL AND INSTALLATION >

[WITHOUT 7 INCH DISPLAY]

UPPER VENTILATOR DUCT : Exploded View

INFOID:000000006258585

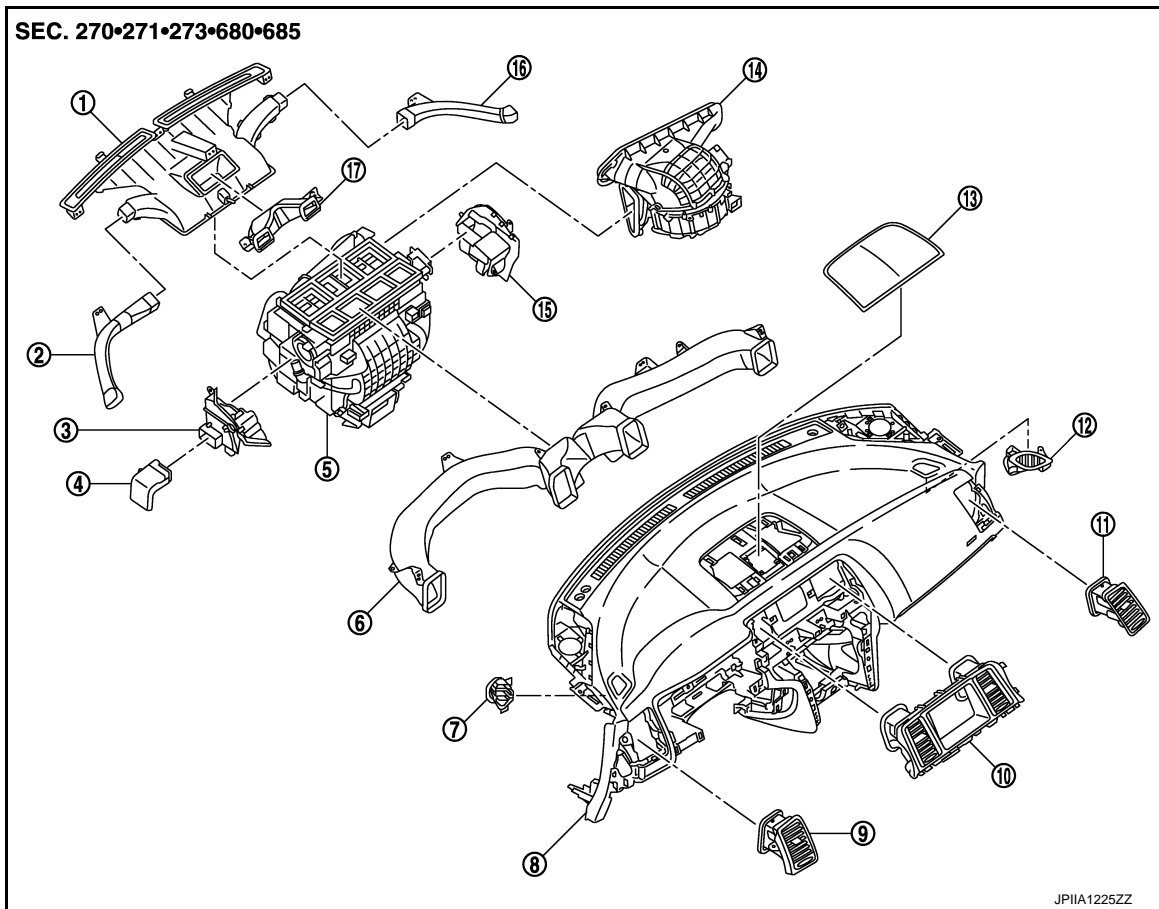

- | | | |
|---------------------------------------|------------------------------------|-----------------------------------|
| 1. Defroster nozzle | 2. Side defroster nozzle (left) | 3. Foot duct (left) |
| 4. Heater duct | 5. Heater & cooling unit assembly | 6. Ventilator duct |
| 7. Side defroster grille (left) | 8. Instrument panel assembly | 9. Side ventilator grille (left) |
| 10. Center ventilator grille assembly | 11. Side ventilator grille (right) | 12. Side defroster grille (right) |
| 13. Center speaker grille | 14. Blower unit assembly | 15. Foot duct (right) |
| 16. Side defroster nozzle (right) | 17. Upper ventilator duct | |

UPPER VENTILATOR DUCT : Removal and Installation

INFOID:000000006258586

REMOVAL

1. Remove the defroster nozzle and side defroster nozzle. Refer to [VTL-53, "DEFROSTER NOZZLE AND SIDE DEFROSTER NOZZLE : Exploded View"](#).
2. Remove the mounting screws (A), and then remove the upper ventilator duct (1).

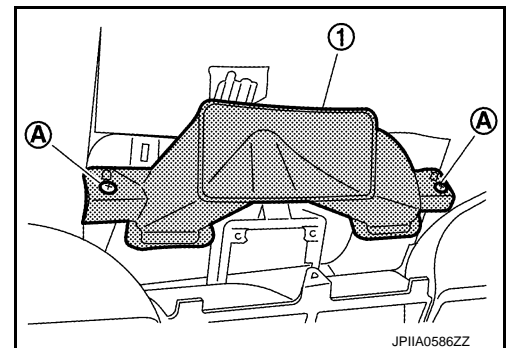

INSTALLATION

Install in the reverse order of removal.

DUCT AND GRILLE

< REMOVAL AND INSTALLATION >

[WITHOUT 7 INCH DISPLAY]

DEFROSTER NOZZLE AND SIDE DEFROSTER NOZZLE

DEFROSTER NOZZLE AND SIDE DEFROSTER NOZZLE : Exploded View

INFOID:000000006258587

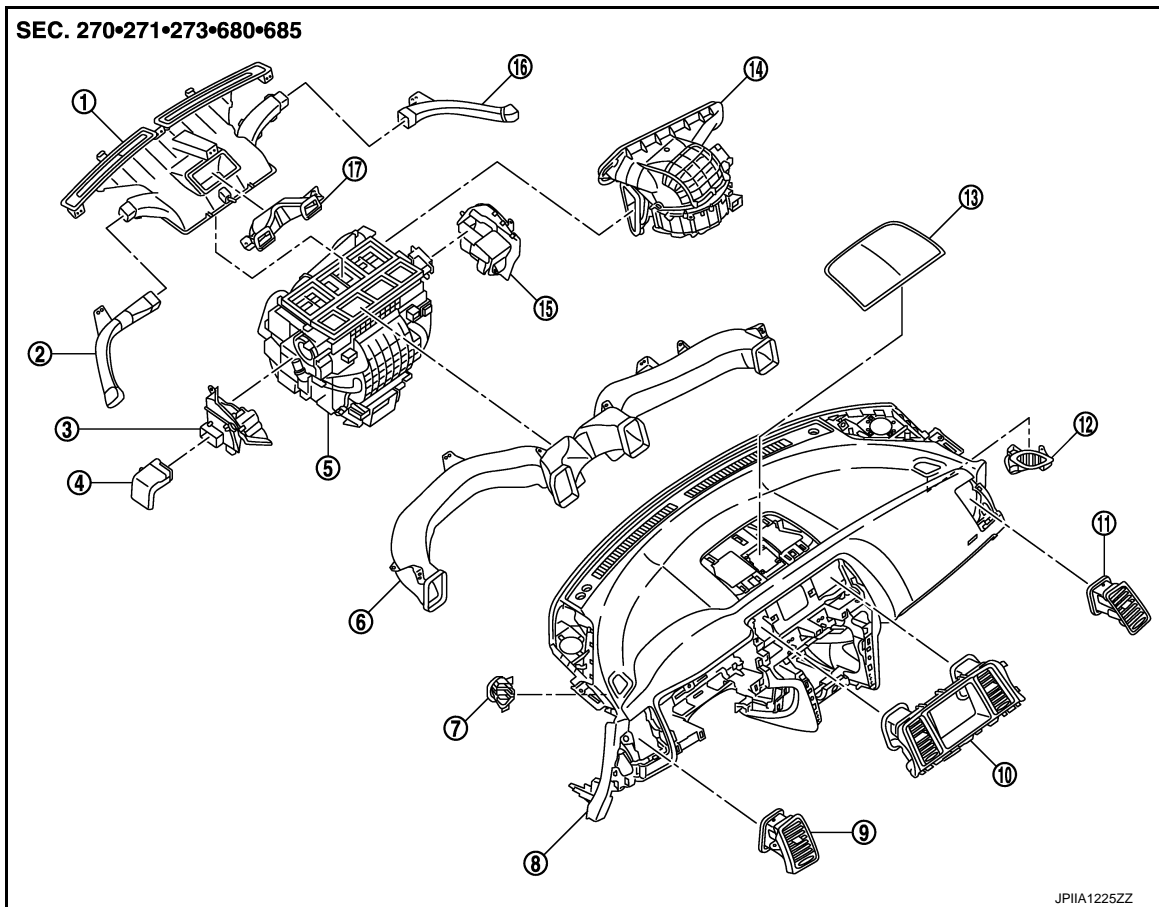

- | | | |
|---------------------------------------|------------------------------------|-----------------------------------|
| 1. Defroster nozzle | 2. Side defroster nozzle (left) | 3. Foot duct (left) |
| 4. Heater duct | 5. Heater & cooling unit assembly | 6. Ventilator duct |
| 7. Side defroster grille (left) | 8. Instrument panel assembly | 9. Side ventilator grille (left) |
| 10. Center ventilator grille assembly | 11. Side ventilator grille (right) | 12. Side defroster grille (right) |
| 13. Center speaker grille | 14. Blower unit assembly | 15. Foot duct (right) |
| 16. Side defroster nozzle (right) | 17. Upper ventilator duct | |

DEFROSTER NOZZLE AND SIDE DEFROSTER NOZZLE : Removal and Installation

INFOID:000000006258588

REMOVAL

1. Remove the instrument panel assembly. Refer to [IP-12, "Exploded View"](#).

DUCT AND GRILLE

< REMOVAL AND INSTALLATION >

[WITHOUT 7 INCH DISPLAY]

2. Remove the mounting screws (A), and then remove the defroster nozzle (1) together with the side defroster nozzle (right) (2) and side defroster nozzle (left) (3).

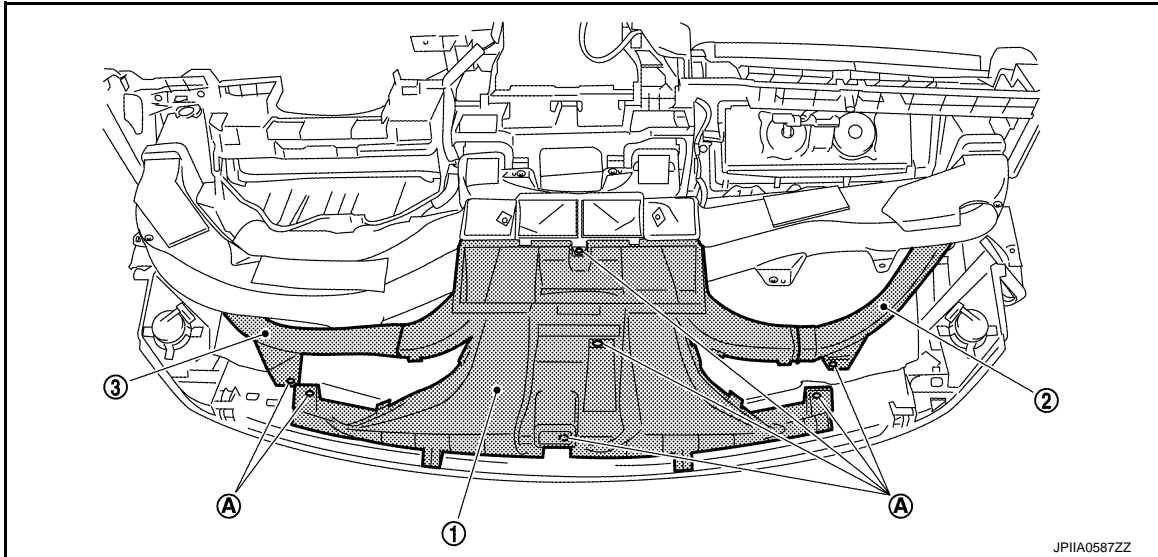

3. Remove the side defroster nozzle (right) and side defroster nozzle (left) from the defroster nozzle.

INSTALLATION

Install in the reverse order of removal.

REAR VENTILATOR GRILLE

REAR VENTILATOR GRILLE : Exploded View

INFOID:000000006258589

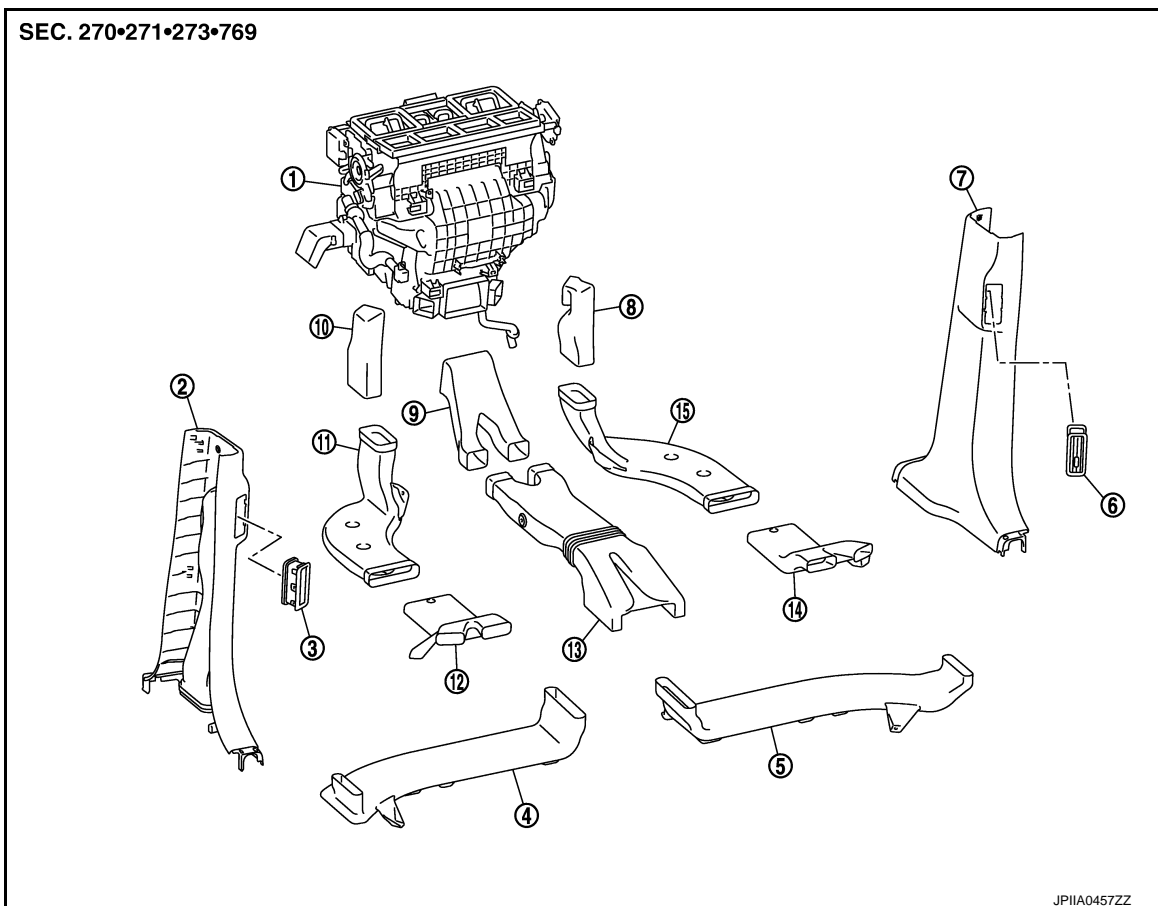

DUCT AND GRILLE

< REMOVAL AND INSTALLATION >

[WITHOUT 7 INCH DISPLAY]

- | | | |
|---|--|-----------------------------------|
| 1. Heater & cooling unit assembly | 2. Rear ventilator duct 4 (center pillar lower garnish left) | 3. Rear ventilator grille (left) |
| 4. Rear ventilator duct 3 (left) | 5. Rear ventilator duct 3 (right) | 6. Rear ventilator grille (right) |
| 7. Rear ventilator duct 4 (center pillar lower garnish right) | 8. Rear foot duct 1 (right) | 9. Rear ventilator duct 1 |
| 10. Rear foot duct 1 (left) | 11. Rear foot duct 2 (left) | 12. Rear foot duct 3 (left) |
| 13. Rear ventilator duct 2 | 14. Rear foot duct 3 (right) | 15. Rear foot duct 2 (right) |

A
B
C

REAR VENTILATOR GRILLE : Removal and Installation

INFOID:000000006258590

REMOVAL

1. Remove the center pillar lower garnish (left/right). Refer to [INT-20, "Exploded View"](#).
2. Disengage the joints of the tabs, and then remove the rear ventilator grilles (left/right) (1).

 :Clip

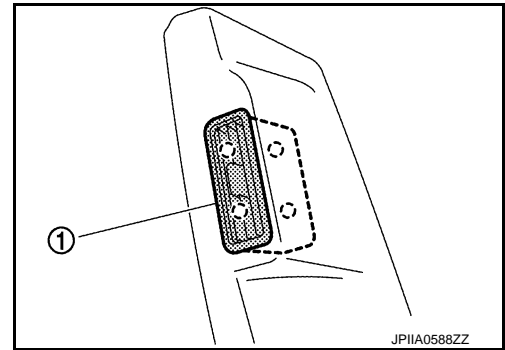

D
E
F
G
H

INSTALLATION

Install in the reverse order of removal.

REAR VENTILATOR DUCT 1

VTL

J
K
L
M
N
O
P

DUCT AND GRILLE

< REMOVAL AND INSTALLATION >

[WITHOUT 7 INCH DISPLAY]

REAR VENTILATOR DUCT 1 : Exploded View

INFOID:000000006258591

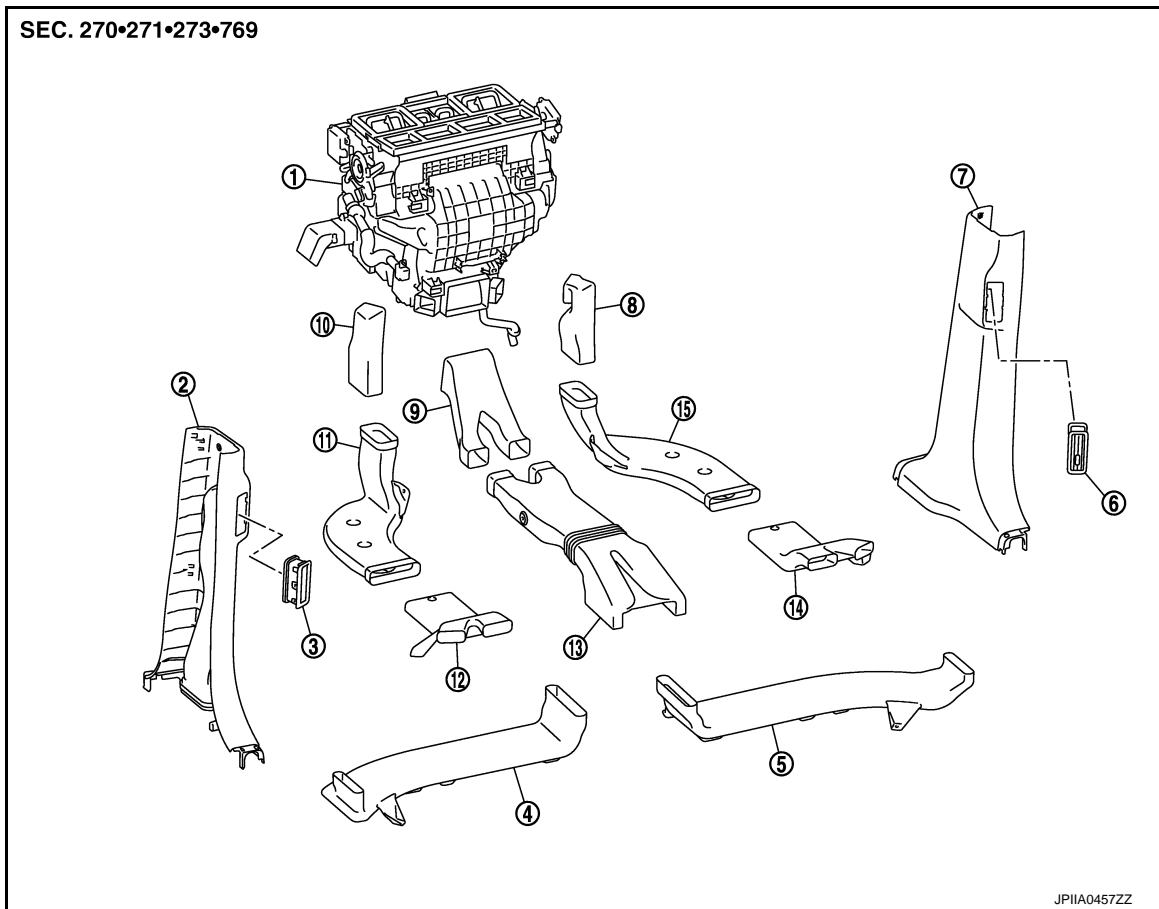

- | | | |
|---|--|-----------------------------------|
| 1. Heater & cooling unit assembly | 2. Rear ventilator duct 4 (center pillar lower garnish left) | 3. Rear ventilator grille (left) |
| 4. Rear ventilator duct 3 (left) | 5. Rear ventilator duct 3 (right) | 6. Rear ventilator grille (right) |
| 7. Rear ventilator duct 4 (center pillar lower garnish right) | 8. Rear foot duct 1 (right) | 9. Rear ventilator duct 1 |
| 10. Rear foot duct 1 (left) | 11. Rear foot duct 2 (left) | 12. Rear foot duct 3 (left) |
| 13. Rear ventilator duct 2 | 14. Rear foot duct 3 (right) | 15. Rear foot duct 2 (right) |

REAR VENTILATOR DUCT 1 : Removal and Installation

INFOID:000000006258592

REMOVAL

1. Remove the rear ventilator duct 2. Refer to [VTL-57, "REAR VENTILATOR DUCT 2 : Exploded View"](#).
2. Remove the rear ventilator duct 1 (1).

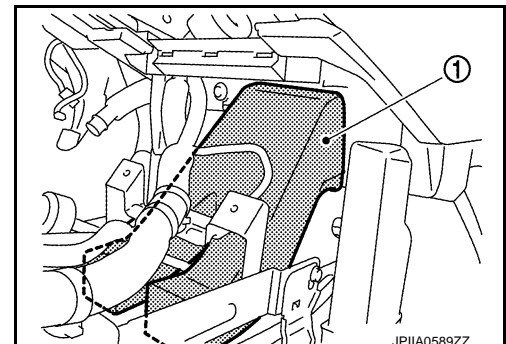

INSTALLATION

Install in the reverse order of removal.

DUCT AND GRILLE

< REMOVAL AND INSTALLATION >

[WITHOUT 7 INCH DISPLAY]

REAR VENTILATOR DUCT 2

REAR VENTILATOR DUCT 2 : Exploded View

INFOID:000000006258593

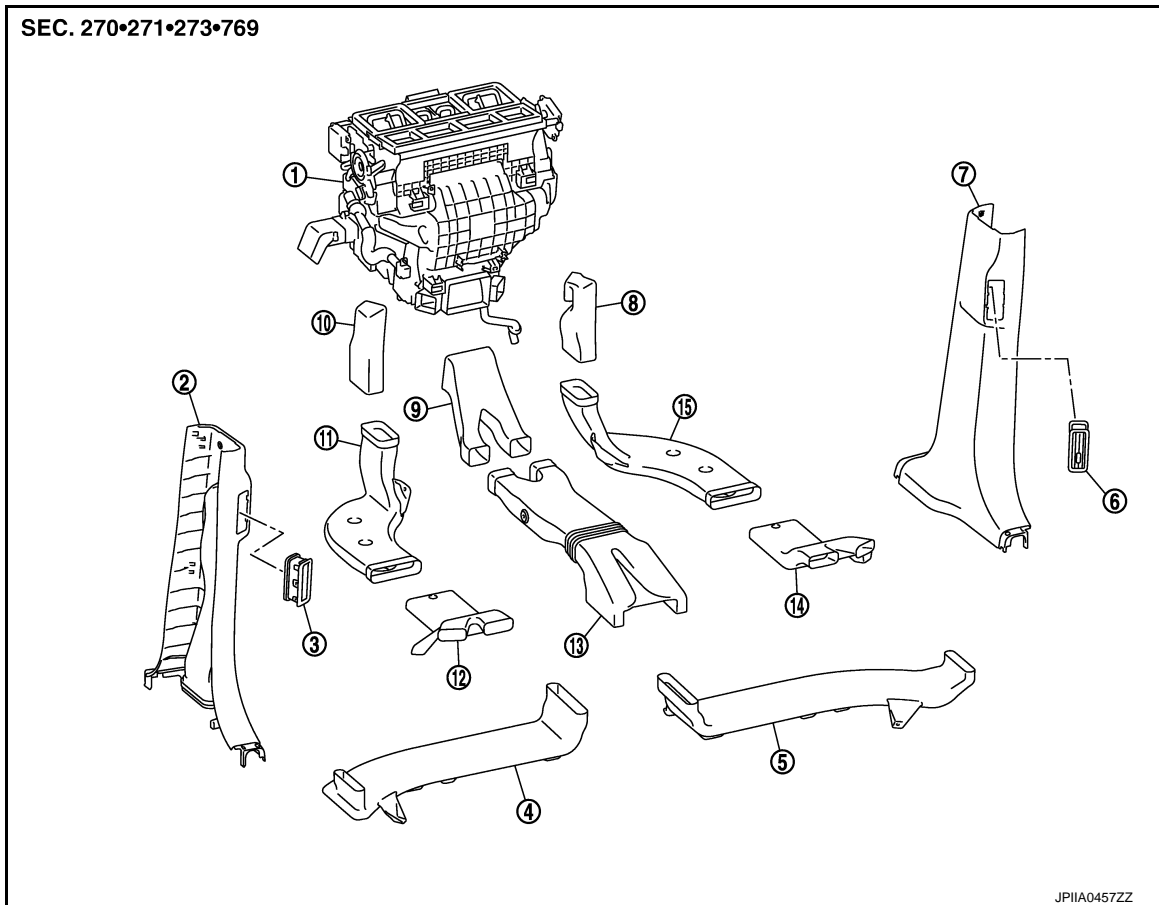

- | | | |
|--|--|-----------------------------------|
| 1. Heater & cooling unit assembly | 2. Rear ventilator duct 4 (center pillar lower | 3. Rear ventilator grille (left |
| | garnish left) | garnish left) |
| 4. Rear ventilator duct 3 (left) | 5. Rear ventilator duct 3 (right) | 6. Rear ventilator grille (right) |
| 7. Rear ventilator duct 4 (center pillar lower | 8. Rear foot duct 1 (right) | 9. Rear ventilator duct 1 |
| garnish right) | | |
| 10. Rear foot duct 1 (left) | 11. Rear foot duct 2 (left) | 12. Rear foot duct 3 (left) |
| 13. Rear ventilator duct 2 | 14. Rear foot duct 3 (right) | 15. Rear foot duct 2 (right) |

REAR VENTILATOR DUCT 2 : Removal and Installation

INFOID:000000006258594

REMOVAL

1. Remove the front seat assembly (left/right). Refer to [SE-90](#), "Exploded View".
2. Remove the lower console finisher (left/right). Refer to [IP-20](#), "Exploded View".
3. Remove the screws (A), nut (B), and clips (C), and then remove rear ventilator duct 2 (1).

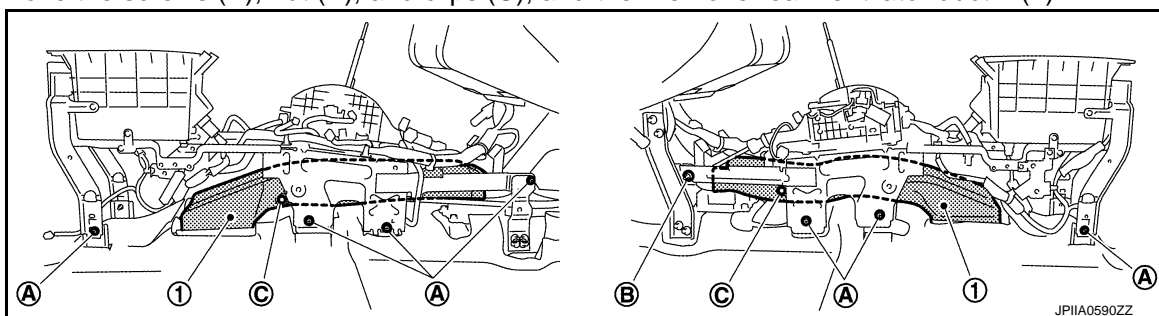

DUCT AND GRILLE

< REMOVAL AND INSTALLATION >

[WITHOUT 7 INCH DISPLAY]

INSTALLATION

Install in the reverse order of removal.

REAR VENTILATOR DUCT 3

REAR VENTILATOR DUCT 3 : Exploded View

INFOID:000000006258595

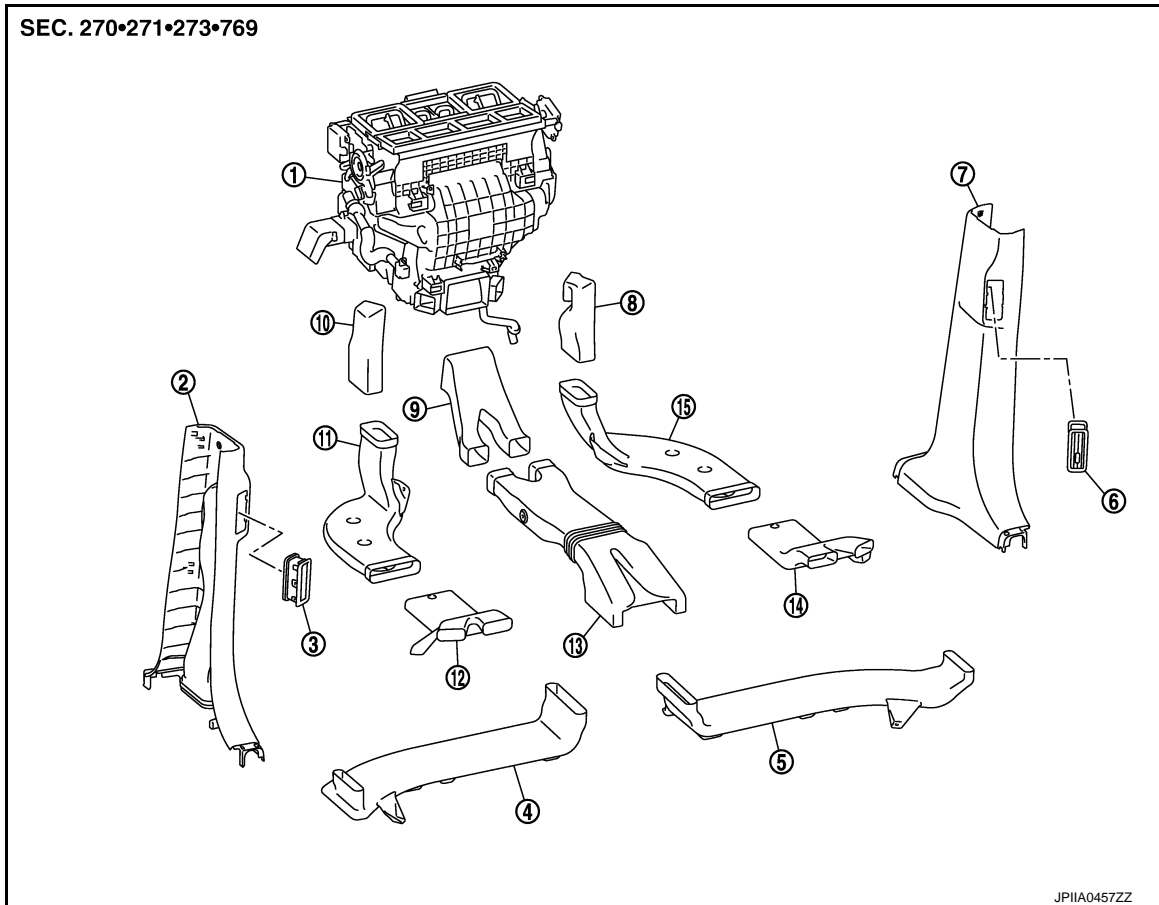

- | | | |
|---|--|-----------------------------------|
| 1. Heater & cooling unit assembly | 2. Rear ventilator duct 4 (center pillar lower garnish left) | 3. Rear ventilator grille (left) |
| 4. Rear ventilator duct 3 (left) | 5. Rear ventilator duct 3 (right) | 6. Rear ventilator grille (right) |
| 7. Rear ventilator duct 4 (center pillar lower garnish right) | 8. Rear foot duct 1 (right) | 9. Rear ventilator duct 1 |
| 10. Rear foot duct 1 (left) | 11. Rear foot duct 2 (left) | 12. Rear foot duct 3 (left) |
| 13. Rear ventilator duct 2 | 14. Rear foot duct 3 (right) | 15. Rear foot duct 2 (right) |

REAR VENTILATOR DUCT 3 : Removal and Installation

INFOID:000000006258596

REMOVAL

Driver side

1. Remove the front seat assembly (left). Refer to [SE-90, "Exploded View"](#).
2. Pull up the driver side floor carpet. Refer to [INT-24, "Exploded View"](#).

DUCT AND GRILLE

< REMOVAL AND INSTALLATION >

[WITHOUT 7 INCH DISPLAY]

3. Remove the mounting screws (A), and then remove rear ventilator duct 3 (left) (1).

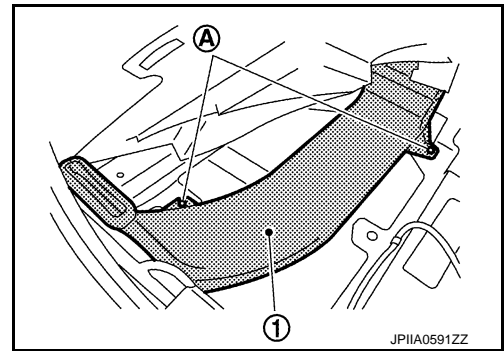

Passenger side

1. Remove the front seat assembly (right). Refer to [SE-90, "Exploded View"](#).
2. Pull up the passenger side floor carpet. Refer to [INT-24, "Exploded View"](#).
3. Remove the mounting screws (A), and then remove rear ventilator duct 3 (right) (1).

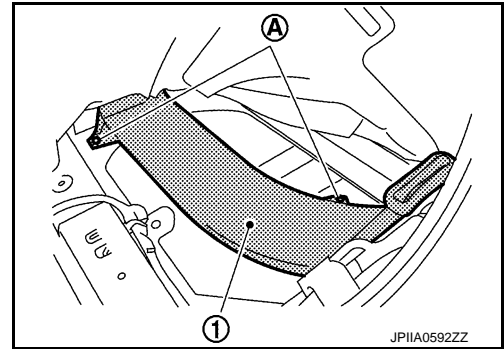

INSTALLATION

Install in the reverse order of removal.

REAR VENTILATOR DUCT 4

A
B
C
D
E
F
G
H
VTL
J
K
L
M
N
O
P

DUCT AND GRILLE

< REMOVAL AND INSTALLATION >

[WITHOUT 7 INCH DISPLAY]

REAR VENTILATOR DUCT 4 : Exploded View

INFOID:000000006258597

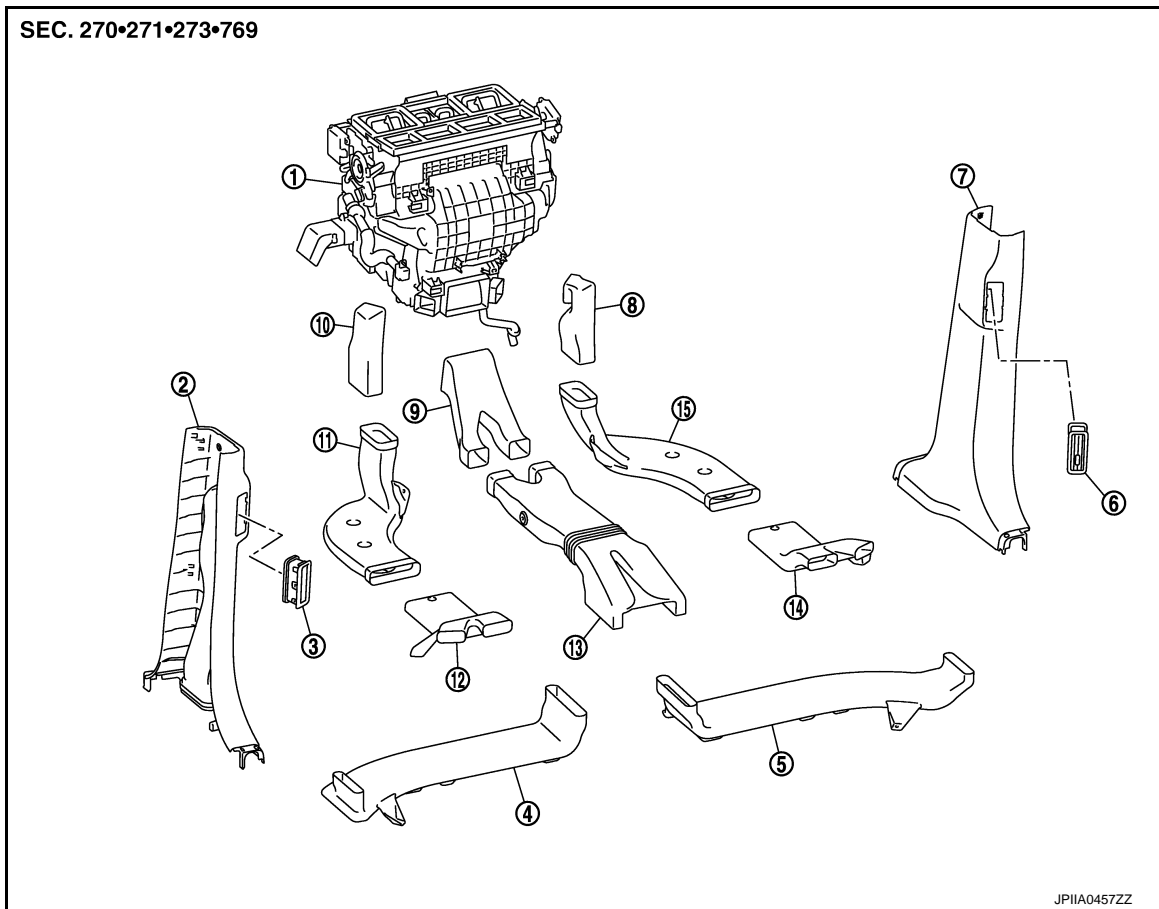

- | | | |
|---|--|-----------------------------------|
| 1. Heater & cooling unit assembly | 2. Rear ventilator duct 4 (center pillar lower garnish left) | 3. Rear ventilator grille (left) |
| 4. Rear ventilator duct 3 (left) | 5. Rear ventilator duct 3 (right) | 6. Rear ventilator grille (right) |
| 7. Rear ventilator duct 4 (center pillar lower garnish right) | 8. Rear foot duct 1 (right) | 9. Rear ventilator duct 1 |
| 10. Rear foot duct 1 (left) | 11. Rear foot duct 2 (left) | 12. Rear foot duct 3 (left) |
| 13. Rear ventilator duct 2 | 14. Rear foot duct 3 (right) | 15. Rear foot duct 2 (right) |

REAR VENTILATOR DUCT 4 : Removal and Installation

INFOID:000000006258598

REMOVAL

1. Remove the center pillar lower garnish (left/right). Refer to [INT-20, "Exploded View"](#).

INSTALLATION

Install in the reverse order of removal.

REAR FOOT DUCT 1

DUCT AND GRILLE

< REMOVAL AND INSTALLATION >

[WITHOUT 7 INCH DISPLAY]

REAR FOOT DUCT 1 : Exploded View

INFOID:000000006258599

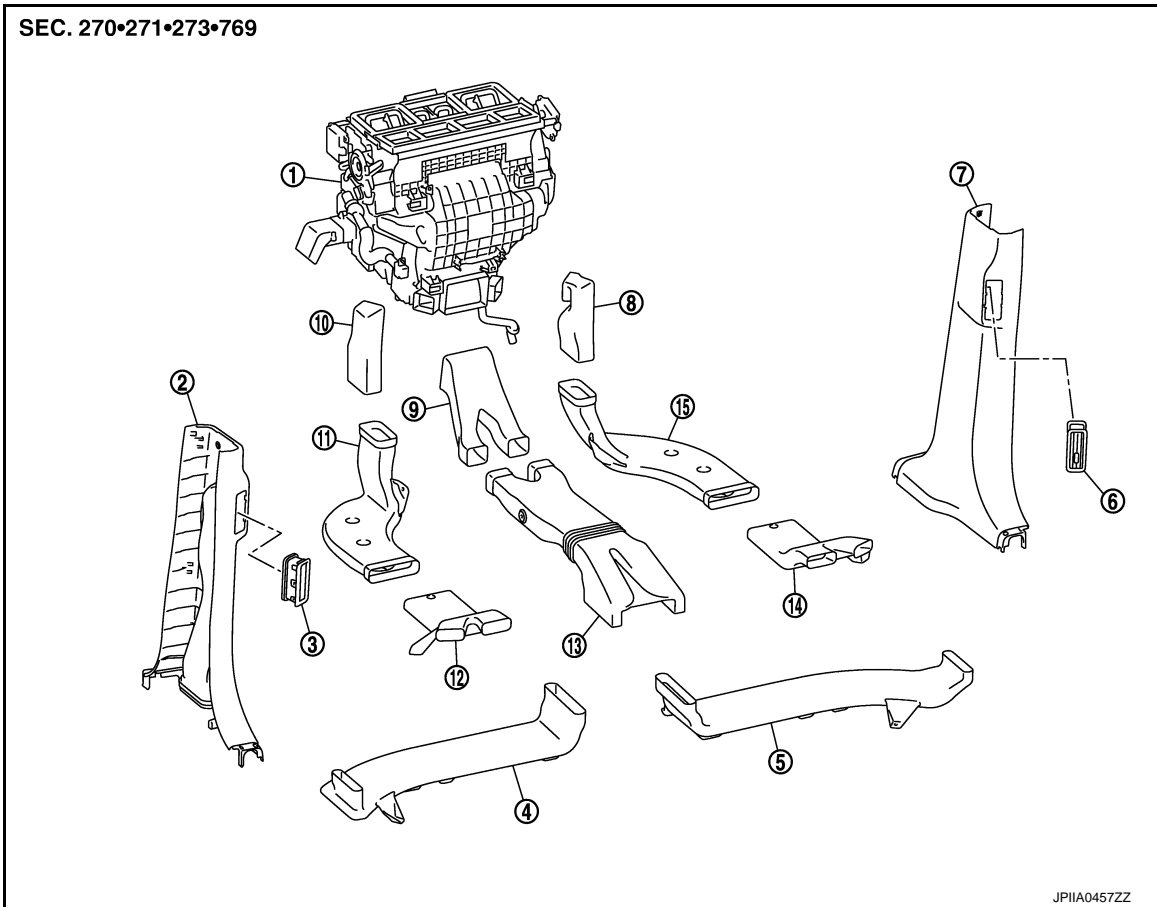

- | | | |
|---|--|-----------------------------------|
| 1. Heater & cooling unit assembly | 2. Rear ventilator duct 4 (center pillar lower garnish left) | 3. Rear ventilator grille (left) |
| 4. Rear ventilator duct 3 (left) | 5. Rear ventilator duct 3 (right) | 6. Rear ventilator grille (right) |
| 7. Rear ventilator duct 4 (center pillar lower garnish right) | 8. Rear foot duct 1 (right) | 9. Rear ventilator duct 1 |
| 10. Rear foot duct 1 (left) | 11. Rear foot duct 2 (left) | 12. Rear foot duct 3 (left) |
| 13. Rear ventilator duct 2 | 14. Rear foot duct 3 (right) | 15. Rear foot duct 2 (right) |

REAR FOOT DUCT 1 : Removal and Installation

INFOID:000000006258600

REMOVAL

Driver side

1. Remove the instrument lower cover LH. Refer to [IP-12, "Exploded View"](#).
2. Remove the rear foot duct 1 (left) (1).

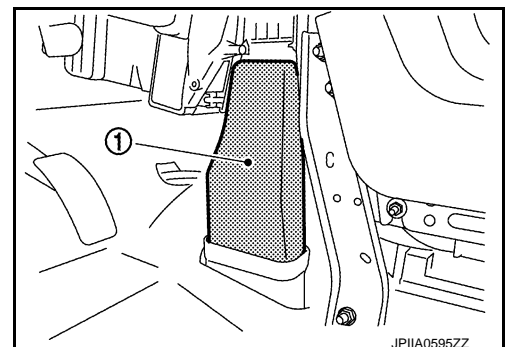

Passenger side

DUCT AND GRILLE

< REMOVAL AND INSTALLATION >

[WITHOUT 7 INCH DISPLAY]

1. Remove the instrument lower cover RH. Refer to [IP-12. "Exploded View"](#).
2. Remove the rear foot duct 1 (right) (1).

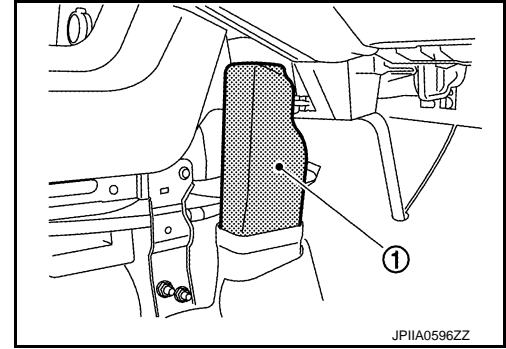

INSTALLATION

Install in the reverse order of removal.

REAR FOOT DUCT 2

REAR FOOT DUCT 2 : Exploded View

INFOID:000000006258601

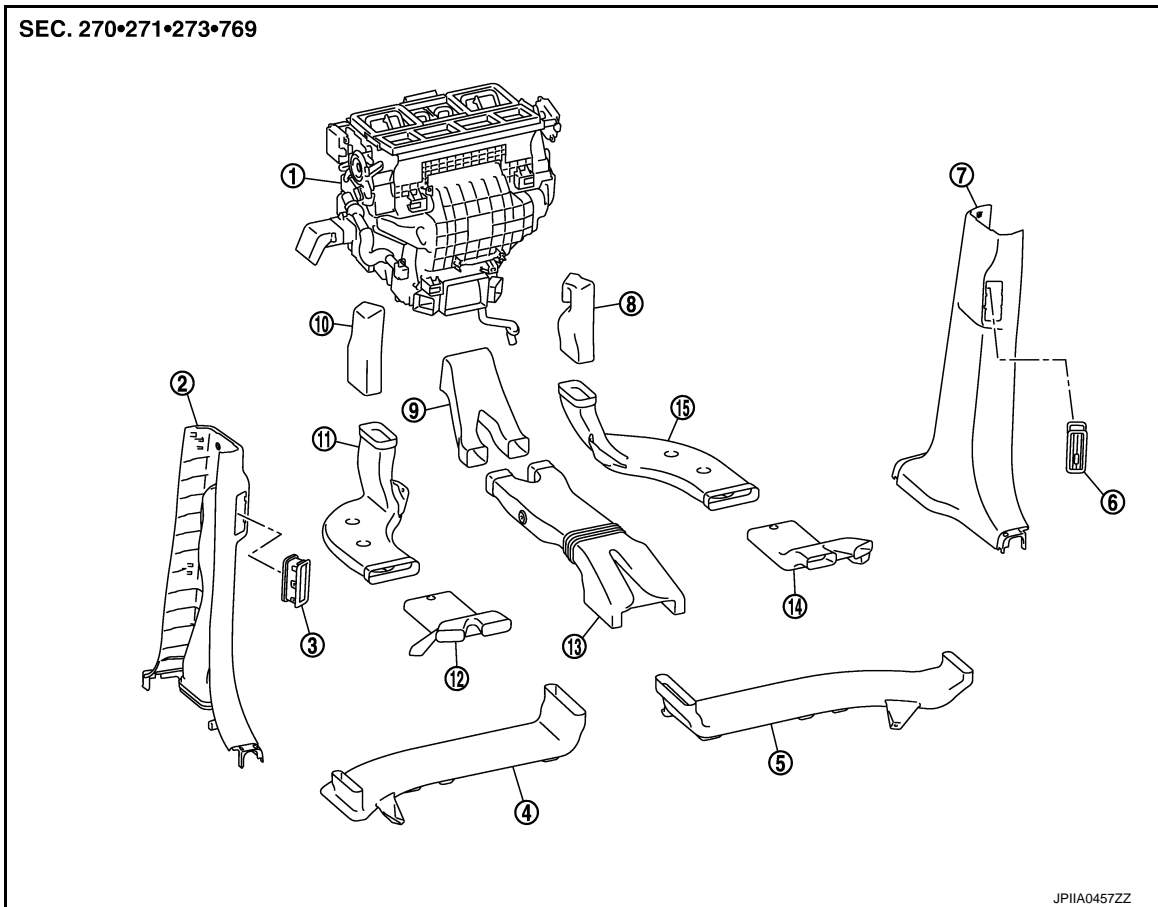

- | | | |
|---|--|-----------------------------------|
| 1. Heater & cooling unit assembly | 2. Rear ventilator duct 4 (center pillar lower garnish left) | 3. Rear ventilator grille (left) |
| 4. Rear ventilator duct 3 (left) | 5. Rear ventilator duct 3 (right) | 6. Rear ventilator grille (right) |
| 7. Rear ventilator duct 4 (center pillar lower garnish right) | 8. Rear foot duct 1 (right) | 9. Rear ventilator duct 1 |
| 10. Rear foot duct 1 (left) | 11. Rear foot duct 2 (left) | 12. Rear foot duct 3 (left) |
| 13. Rear ventilator duct 2 | 14. Rear foot duct 3 (right) | 15. Rear foot duct 2 (right) |

DUCT AND GRILLE

< REMOVAL AND INSTALLATION >

[WITHOUT 7 INCH DISPLAY]

REAR FOOT DUCT 2 : Removal and Installation

INFOID:000000006258602

REMOVAL

Driver side

1. Remove the rear foot duct 1 (left). Refer to [VTL-61, "REAR FOOT DUCT 1 : Exploded View"](#).
2. Pull up the driver side floor carpet. Refer to [INT-24, "Exploded View"](#).
3. Remove the mounting clip (A), and then remove the rear foot duct 2 (left) (1).

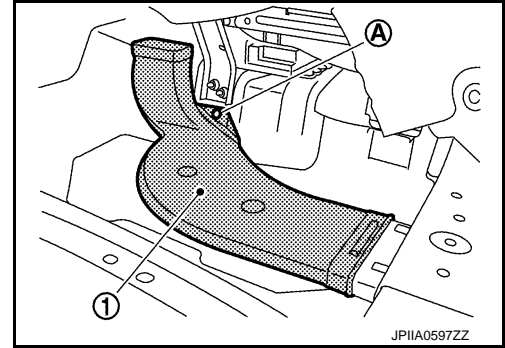

Passenger side

1. Remove the rear foot duct 1 (right). Refer to [VTL-61, "REAR FOOT DUCT 1 : Exploded View"](#).
2. Pull up the passenger side floor carpet. Refer to [INT-24, "Exploded View"](#).
3. Remove the mounting clip (A), and then remove the rear foot duct 2 (right) (1).

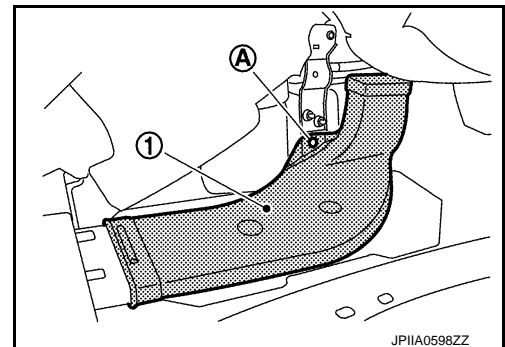

INSTALLATION

Install in the reverse order of removal.

REAR FOOT DUCT 3

A
B
C
D
E
F
G
H
VTL
J
K
L
M
N
O
P

DUCT AND GRILLE

< REMOVAL AND INSTALLATION >

[WITHOUT 7 INCH DISPLAY]

REAR FOOT DUCT 3 : Exploded View

INFOID:000000006258603

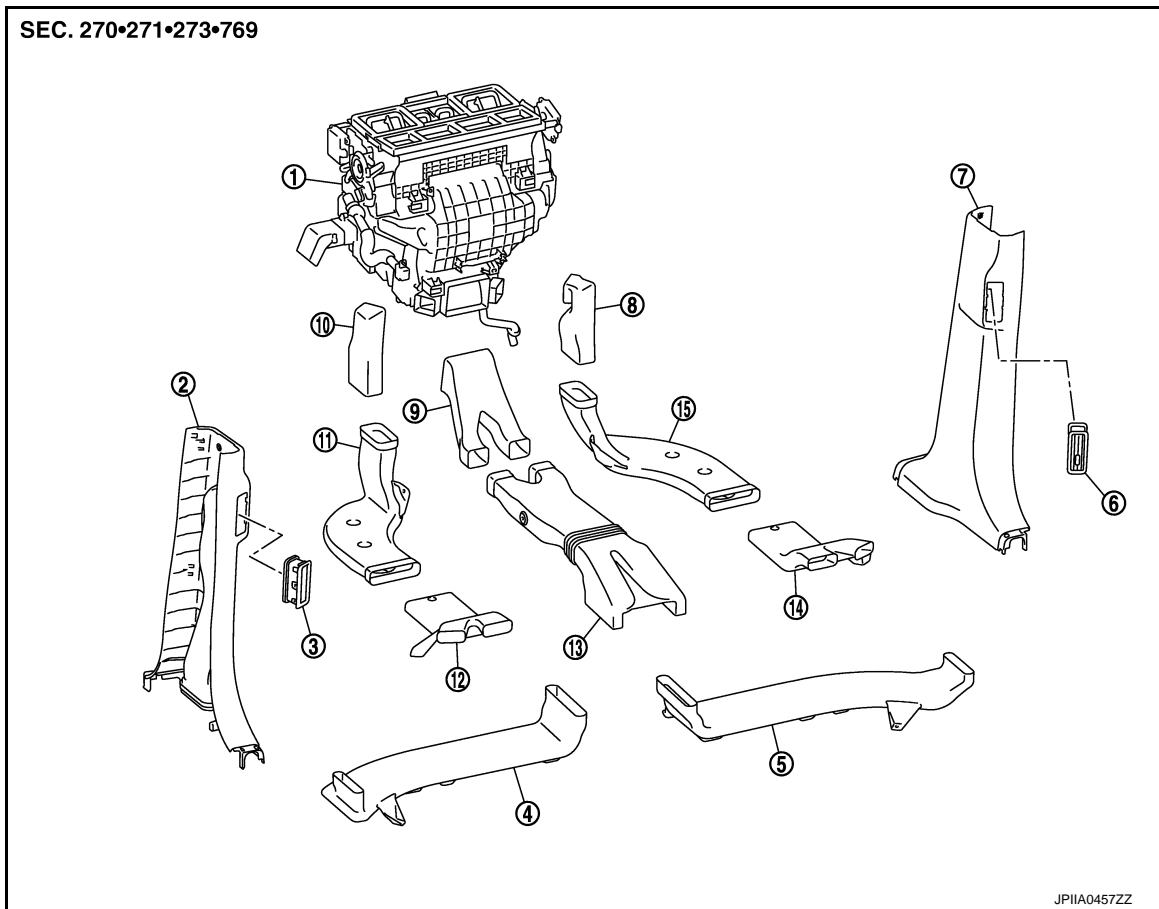

- | | | |
|---|--|-----------------------------------|
| 1. Heater & cooling unit assembly | 2. Rear ventilator duct 4 (center pillar lower garnish left) | 3. Rear ventilator grille (left) |
| 4. Rear ventilator duct 3 (left) | 5. Rear ventilator duct 3 (right) | 6. Rear ventilator grille (right) |
| 7. Rear ventilator duct 4 (center pillar lower garnish right) | 8. Rear foot duct 1 (right) | 9. Rear ventilator duct 1 |
| 10. Rear foot duct 1 (left) | 11. Rear foot duct 2 (left) | 12. Rear foot duct 3 (left) |
| 13. Rear ventilator duct 2 | 14. Rear foot duct 3 (right) | 15. Rear foot duct 2 (right) |

REAR FOOT DUCT 3 : Removal and Installation

INFOID:000000006258604

REMOVAL

Driver side

1. Remove the rear foot duct 2 (left). Refer to [VTL-62, "REAR FOOT DUCT 2 : Exploded View"](#).
2. Remove the mounting screw (A), and then remove the rear foot duct 3 (left) (1).

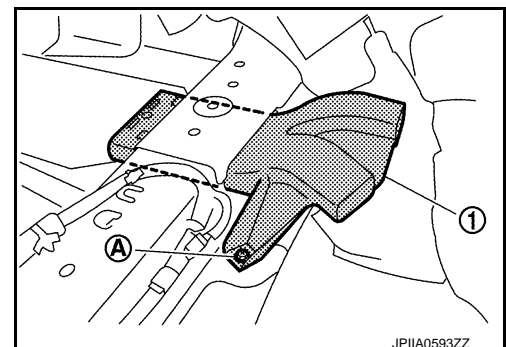

Passenger side

DUCT AND GRILLE

< REMOVAL AND INSTALLATION >

[WITHOUT 7 INCH DISPLAY]

1. Remove the rear foot duct 2 (right). Refer to [VTL-62. "REAR FOOT DUCT 2 : Exploded View"](#).
2. Remove the mounting screw (A), and then remove the rear foot duct 3 (right) (1).

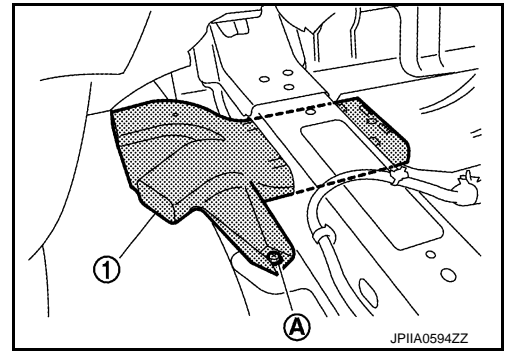

INSTALLATION

Install in the reverse order of removal.

HEATER DUCT

HEATER DUCT : Exploded View

INFOID:000000006258605

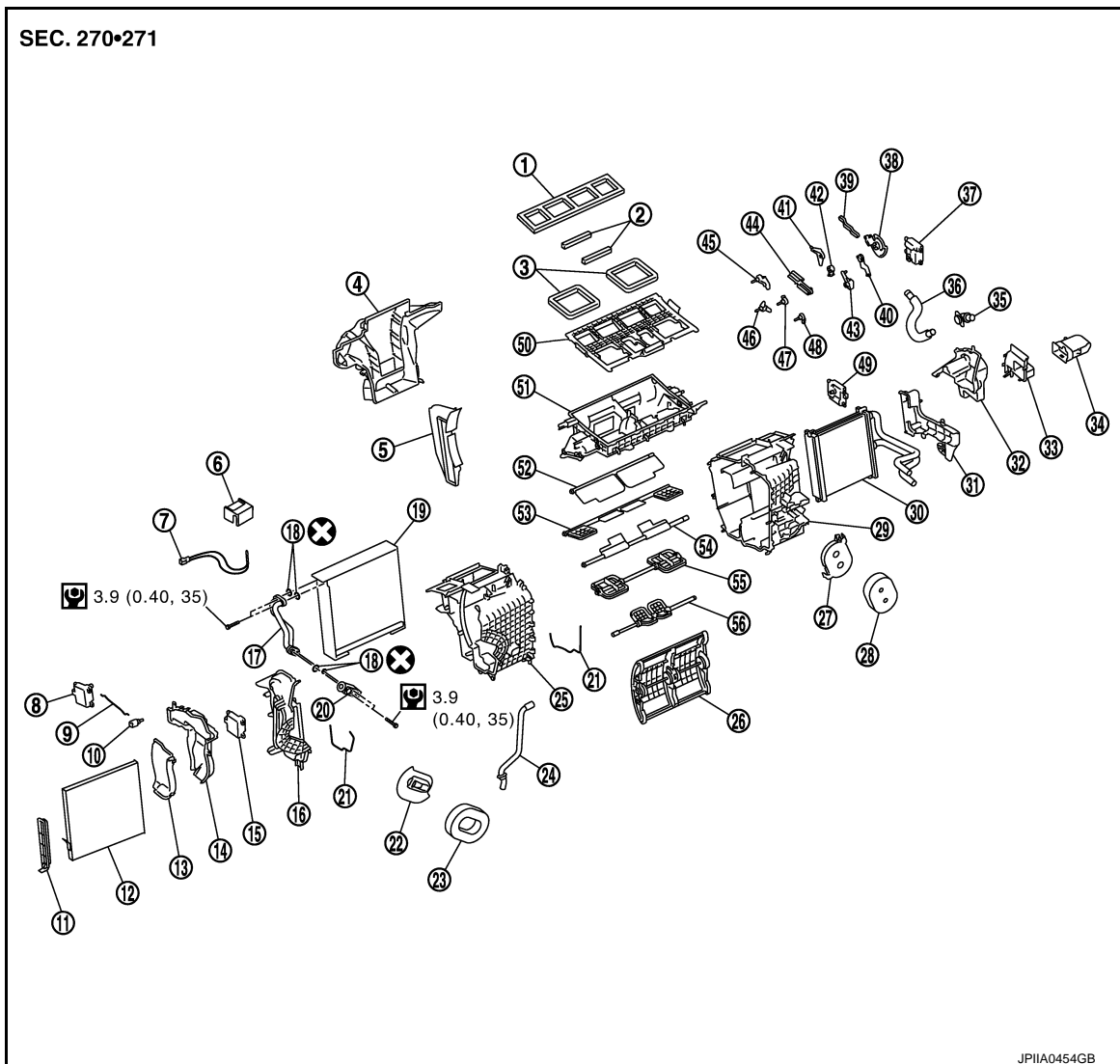

- | | | |
|--------------------|--------------------------------|------------------------------|
| 1. Ventilator seal | 2. Upper ventilator seal | 3. Defroster seal |
| 4. Adapter case | 5. Center case | 6. Intake sensor bracket |
| 7. Intake sensor | 8. Upper ventilator door motor | 9. Upper ventilator door rod |

DUCT AND GRILLE

< REMOVAL AND INSTALLATION >

[WITHOUT 7 INCH DISPLAY]

- | | | |
|--|---------------------------------------|--|
| 10. Upper ventilator door lever | 11. Filter cover | 12. In-cabin microfilter/Air conditioner filter* |
| 13. Foot duct 1 (right) | 14. Foot duct 2 (right) | 15. Air mix door motor (passenger side) |
| 16. Heater & cooling unit case cover | 17. Evaporator pipe assembly | 18. O-ring |
| 19. Evaporator | 20. Expansion valve | 21. Case packing |
| 22. Grommet | 23. Cooler pipe grommet | 24. Drain hose |
| 25. Heater & cooling unit case (right) | 26. Air mix door (Slide door) | 27. Heater pipe support |
| 28. Heater pipe grommet | 29. Heater & cooling unit case (left) | 30. Heater core |
| 31. Heater pipe cover | 32. Foot duct 2 (left) | 33. Foot duct 1 (left) |
| 34. Heater duct | 35. Aspirator | 36. Aspirator hose |
| 37. Mode door motor | 38. Main link | 39. Rod link |
| 40. Max. cool door link | 41. Ventilator door link | 42. Foot door link |
| 43. Mode door lever | 44. Defroster door link | 45. Ventilator door lever |
| 46. Foot door lever | 47. Defroster door lever | 48. Max. cool door lever |
| 49. Air mix door motor (driver side) | 50. Distributor upper case | 51. Distributor lower case |
| 52. Ventilator door | 53. Foot door | 54. Max. cool door |
| 55. Defroster door | 56. Upper ventilator door | |

* : Models for Mexico.

Refer to [GI-4, "Components"](#) for symbols in the figure.

HEATER DUCT : Removal and Installation

INFOID:000000006258606

REMOVAL

1. Remove the instrument lower panel LH. Refer to [IP-12, "Exploded View"](#).
2. Remove the mounting screw (A), and then remove the heater duct (1).

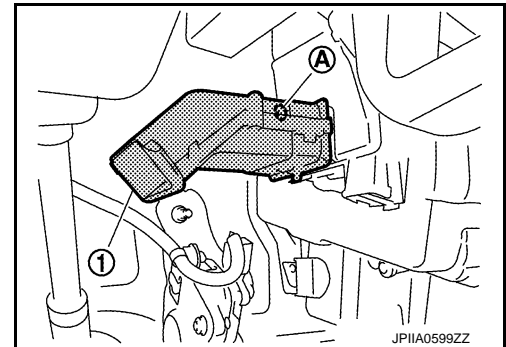

INSTALLATION

Install in the reverse order of removal.

FOOT DUCT

DUCT AND GRILLE

< REMOVAL AND INSTALLATION >

[WITHOUT 7 INCH DISPLAY]

FOOT DUCT : Exploded View

INFOID:000000006258607

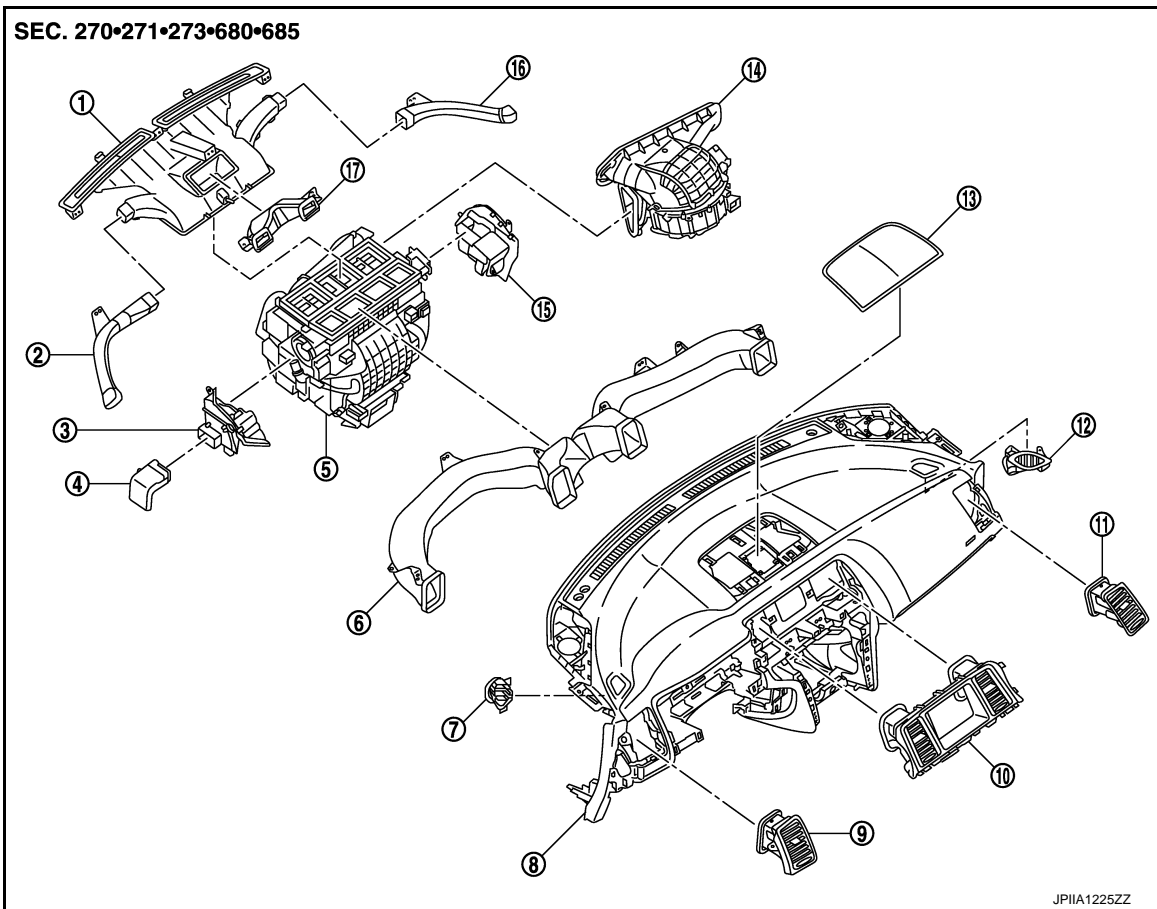

- | | | |
|---------------------------------------|------------------------------------|-----------------------------------|
| 1. Defroster nozzle | 2. Side defroster nozzle (left) | 3. Foot duct (left) |
| 4. Heater duct | 5. Heater & cooling unit assembly | 6. Ventilator duct |
| 7. Side defroster grille (left) | 8. Instrument panel assembly | 9. Side ventilator grille (left) |
| 10. Center ventilator grille assembly | 11. Side ventilator grille (right) | 12. Side defroster grille (right) |
| 13. Center speaker grille | 14. Blower unit assembly | 15. Foot duct (right) |
| 16. Side defroster nozzle (right) | 17. Upper ventilator duct | |

FOOT DUCT : Removal and Installation

INFOID:000000006258608

REMOVAL

Driver side

1. Remove instrument lower panel LH. Refer to [IP-12, "Exploded View"](#).
2. Remove mounting screws (A), and then remove foot duct (left) (1).

← : Vehicle front

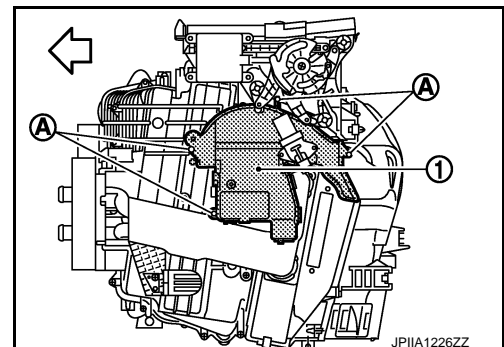

Passenger side

DUCT AND GRILLE

< REMOVAL AND INSTALLATION >

[WITHOUT 7 INCH DISPLAY]

1. Remove blower unit assembly. Refer to [VTL-30. "Exploded View"](#).
2. Remove mounting screws (A) and harness clip, and then remove foot duct (right) (1).

← : Vehicle front

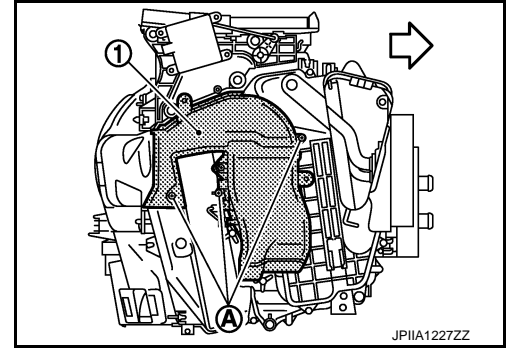

INSTALLATION

Installation is basically the reverse order of removal.

SWITCHES AND THEIR CONTROL FUNCTION

< SYSTEM DESCRIPTION >

[WITH 7 INCH DISPLAY]

SYSTEM DESCRIPTION

SWITCHES AND THEIR CONTROL FUNCTION

System Description

INFOID:000000006258609

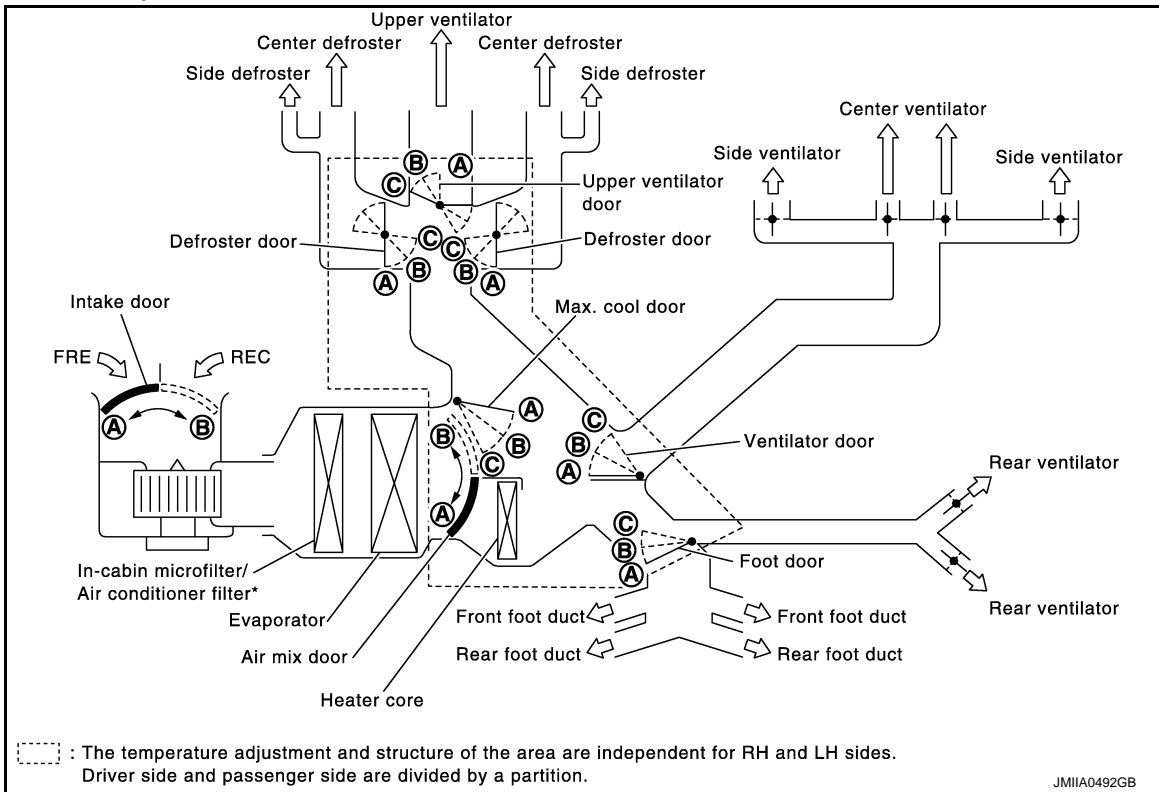

* : Models for Mexico.











A
B
C
D
E
F
G
H
J
K
L
M
N
O
P

VTL

SWITCHES AND THEIR CONTROL FUNCTION

< SYSTEM DESCRIPTION >

[WITH 7 INCH DISPLAY]

Switch position			Door position								
			Ventilator door	Max. cool door	Defroster door	Foot door	Upper ventilator door	Intake door	Air mix door (Driver side)	Air mix door (Passenger side)	
AUTO switch			AUTO						AUTO		
MODE switch	VENT		A	A	A	A	—	—			
	B/L		B	B	A	B					
	FOOT		C	B	B	C					
	D/F		C	B	B	B					
DEF switch			C	C	C	A		B	—	—	
UPPER VENT switch	ON		—				A-B	—			
	OFF						C				
Intake switch	ON							A*			
	OFF							B*			
Temperature control dial (Driver side)	DUAL switch: OFF	18.0°C (60°F)							A		
		18.5°C ⇔ 31.5°C (61°F ⇔ 89°F)							AUTO		
		32.0°C (90°F)							B		
Temperature control dial (Driver side)	DUAL switch: ON	18.0°C (60°F)	—	—	—	—	—	A	—		
		18.5°C ⇔ 31.5°C (61°F ⇔ 89°F)						AUTO			
		32.0°C (90°F)						B			
Temperature control dial (Passenger side)	ON	18.0°C (60°F)							A		
		18.5°C ⇔ 31.5°C (61°F ⇔ 89°F)							—		AUTO
		32.0°C (90°F)							—		B
ON/OFF switch			C	C	B	C	—	B	—	—	

*: Inlet status is displayed by indicator when activating automatic control.

AIR DISTRIBUTION





< SYSTEM DESCRIPTION >

[WITH 7 INCH DISPLAY]





AIR DISTRIBUTION

System Description

INFOID:000000006258610

Discharge air flow							
Mode position indication	Condition	Air outlet/distribution					
		VENT			FOOT		DEF
		Front	Upper	Rear	Front	Rear	
	DUAL switch: OFF UPPER VENT switch : ON	81%	8%	11%	—	—	—
		41%	10%	17%	24%	8%	—
		12%	12%	16%	27%	10%	23%
		11%	11%	14%	25%	10%	29%
		11%	11%	12%	—	—	66%

JPIIA0509GB

Discharge air flow							
Mode position indication	Condition	Air outlet/distribution					
		VENT			FOOT		DEF
		Front	Upper	Rear	Front	Rear	
	DUAL switch: OFF UPPER VENT switch : OFF	88%	—	12%	—	—	—
		47%	—	18%	26%	9%	—
		13%	—	17%	33%	12%	25%
		12%	—	16%	28%	12%	32%
		11%	—	15%	—	—	74%

JPIIA0510GB

A
B
C
D
E
F
G
H
VTL
J
K
L
M
N
O
P

PRECAUTION**PRECAUTIONS****FOR USA AND CANADA****FOR USA AND CANADA : Precaution for Supplemental Restraint System (SRS) "AIR BAG" and "SEAT BELT PRE-TENSIONER"**

INFOID:000000006258611

The Supplemental Restraint System such as "AIR BAG" and "SEAT BELT PRE-TENSIONER", used along with a front seat belt, helps to reduce the risk or severity of injury to the driver and front passenger for certain types of collision. This system includes seat belt switch inputs and dual stage front air bag modules. The SRS system uses the seat belt switches to determine the front air bag deployment, and may only deploy one front air bag, depending on the severity of a collision and whether the front occupants are belted or unbelted.

Information necessary to service the system safely is included in the "SRS AIR BAG" and "SEAT BELT" of this Service Manual.

WARNING:

Always observe the following items for preventing accidental activation.

- **To avoid rendering the SRS inoperative, which could increase the risk of personal injury or death in the event of a collision that would result in air bag inflation, all maintenance must be performed by an authorized NISSAN/INFINITI dealer.**
- **Improper maintenance, including incorrect removal and installation of the SRS, can lead to personal injury caused by unintentional activation of the system. For removal of Spiral Cable and Air Bag Module, see "SRS AIR BAG".**
- **Never use electrical test equipment on any circuit related to the SRS unless instructed to in this Service Manual. SRS wiring harnesses can be identified by yellow and/or orange harnesses or harness connectors.**

PRECAUTIONS WHEN USING POWER TOOLS (AIR OR ELECTRIC) AND HAMMERS**WARNING:**

Always observe the following items for preventing accidental activation.

- **When working near the Air Bag Diagnosis Sensor Unit or other Air Bag System sensors with the ignition ON or engine running, never use air or electric power tools or strike near the sensor(s) with a hammer. Heavy vibration could activate the sensor(s) and deploy the air bag(s), possibly causing serious injury.**
- **When using air or electric power tools or hammers, always switch the ignition OFF, disconnect the battery, and wait at least 3 minutes before performing any service.**

FOR MEXICO**FOR MEXICO : Precaution for Supplemental Restraint System (SRS) "AIR BAG" and "SEAT BELT PRE-TENSIONER"**

INFOID:000000006258612

The Supplemental Restraint System such as "AIR BAG" and "SEAT BELT PRE-TENSIONER", used along with a front seat belt, helps to reduce the risk or severity of injury to the driver and front passenger for certain types of collision. Information necessary to service the system safely is included in the "SRS AIR BAG" and "SEAT BELT" of this Service Manual.

WARNING:

Always observe the following items for preventing accidental activation.

- **To avoid rendering the SRS inoperative, which could increase the risk of personal injury or death in the event of a collision that would result in air bag inflation, all maintenance must be performed by an authorized NISSAN/INFINITI dealer.**
- **Improper maintenance, including incorrect removal and installation of the SRS, can lead to personal injury caused by unintentional activation of the system. For removal of Spiral Cable and Air Bag Module, see "SRS AIR BAG".**
- **Never use electrical test equipment on any circuit related to the SRS unless instructed to in this Service Manual. SRS wiring harnesses can be identified by yellow and/or orange harnesses or harness connectors.**

PRECAUTIONS WHEN USING POWER TOOLS (AIR OR ELECTRIC) AND HAMMERS**WARNING:**

PRECAUTIONS

< PRECAUTION >

[WITH 7 INCH DISPLAY]

Always observe the following items for preventing accidental activation.

- When working near the Air Bag Diagnosis Sensor Unit or other Air Bag System sensors with the ignition ON or engine running, never use air or electric power tools or strike near the sensor(s) with a hammer. Heavy vibration could activate the sensor(s) and deploy the air bag(s), possibly causing serious injury.
- When using air or electric power tools or hammers, always switch the ignition OFF, disconnect the battery, and wait at least 3 minutes before performing any service.

Precaution for Procedure without Cowl Top Cover

INFOID:000000006258614

When performing the procedure after removing cowl top cover, cover the lower end of windshield with urethane, etc to prevent damage to windshield.

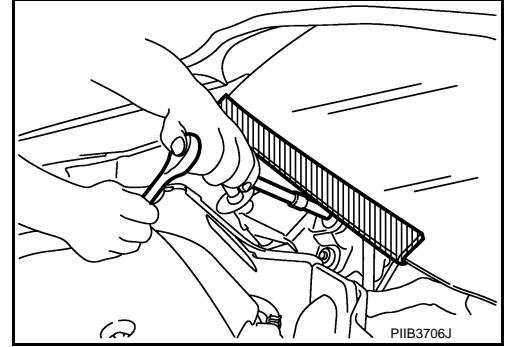

Precautions For Xenon Headlamp Service

INFOID:000000006258615

WARNING:

Comply with the following warnings to prevent any serious accident.

- Disconnect the battery cable (negative terminal) or the power supply fuse before installing, removing, or touching the xenon headlamp (bulb included). The xenon headlamp contains high-voltage generated parts.
- Never work with wet hands.
- Check the xenon headlamp ON-OFF status after assembling it to the vehicle. Never turn the xenon headlamp ON in other conditions. Connect the power supply to the vehicle-side connector. (Turning it ON outside the lamp case may cause fire or visual impairments.)
- Never touch the bulb glass immediately after turning it OFF. It is extremely hot.

CAUTION:

Comply with the following cautions to prevent any error and malfunction.

- Install the xenon bulb securely. (Insufficient bulb socket installation may melt the bulb, the connector, the housing, etc. by high-voltage leakage or corona discharge.)
- Never perform HID circuit inspection with a tester.
- Never touch the xenon bulb glass with hands. Never put oil and grease on it.
- Dispose of the used xenon bulb after packing it in thick vinyl without breaking it.
- Never wipe out dirt and contamination with organic solvent (thinner, gasoline, etc.).

Working with HFC-134a (R-134a)

INFOID:000000006258616

CAUTION:

- CFC-12 (R-12) refrigerant and HFC-134a (R-134a) refrigerant are not compatible. Compressor malfunction is likely to occur if the refrigerants are mixed, refer to "CONTAMINATED REFRIGERANT" below. To determine the purity of HFC-134a (R-134a) in the vehicle and recovery tank, use Refrigerant Recovery/Recycling Recharging equipment and Refrigerant Identifier.
- Use only specified lubricant for the HFC-134a (R-134a) A/C system and HFC-134a (R-134a) components. Compressor malfunction is likely to occur if lubricant other than that specified is used.
- The specified HFC-134a (R-134a) lubricant rapidly absorbs moisture from the atmosphere. The following handling precautions must be observed:
 - Immediately cap (seal) immediately the component to minimize the entry of moisture from the atmosphere when removing refrigerant components from a vehicle.
 - Never remove the caps (unseal) until just before connecting the components when installing refrigerant components to a vehicle. Connect all refrigerant loop components as quickly as possible to minimize the entry of moisture into system.
 - Use only the specified lubricant from a sealed container. Immediately reseal containers of lubricant. Lubricant becomes saturated with moisture and should not be used without proper sealing.

A
B
C
D
E
F
G
H
J
K
L
M
N
O
P

VTL

PRECAUTIONS

< PRECAUTION >

[WITH 7 INCH DISPLAY]

- **Never allow lubricant (NISSAN A/C System Oil Type S) to come in to contact with styrene foam parts. Damage may result.**

CONTAMINATED REFRIGERANT

Take the appropriate steps shown below if a refrigerant other than pure HFC-134a (R-134a) is identified in a vehicle:

- Explain to the customer that environmental regulations prohibit the release of contaminated refrigerant into the atmosphere.
- Explain that recovery of the contaminated refrigerant could damage service equipment and refrigerant supply.
- Suggest the customer return the vehicle to the location of previous service where the contamination may have occurred.
- If repairing, recover the refrigerant using only **dedicated equipment and containers. Never reintroduce contaminated refrigerant into the existing service equipment.** Contact a local refrigerant product retailer for available service if the facility does not have dedicated recovery equipment. This refrigerant must be disposed of in accordance with all federal and local regulations. In addition, replacement of all refrigerant system components on the vehicle is recommended.
- The air conditioner warranty is void if the vehicle is within the warranty period. Please contact Nissan Customer Affairs for further assistance.

General Refrigerant Precaution

INFOID:000000006258617

WARNING:

- **Never breathe A/C refrigerant and lubricant vapor or mist. Exposure may irritate eyes, nose or throat. Remove HFC-134a (R-134a) from the A/C system, using certified service equipment meeting requirements of SAE J-2210 [HFC-134a (R-134a) recycling equipment], or J-2209 [HFC-134a (R-134a) recovery equipment]. Ventilate the work area before resuming service if accidental system discharge occurs. Additional health and safety information may be obtained from refrigerant and lubricant manufacturers.**
- **Never release refrigerant into the air. Use approved recovery/recycling equipment to capture the refrigerant each time an air conditioning system is discharged.**
- **Always wear eye and hand protection (goggles and gloves) when working with any refrigerant or air conditioning system.**
- **Never store or heat refrigerant containers above 52°C (126°F).**
- **Never heat a refrigerant container with an open flame. Place the bottom of the container in a warm pail of water if container warming is required.**
- **Never intentionally drop, puncture, or incinerate refrigerant containers.**
- **Keep refrigerant away from open flames. Poisonous gas is produced if refrigerant burns.**
- **Refrigerant displaces oxygen, therefore be certain to work in well ventilated areas to prevent suffocation.**
- **Never pressure test or leakage test HFC-134a (R-134a) service equipment and/or vehicle air conditioning systems with compressed air during repair. Some mixtures of air and HFC-134a (R-134a) have proven to be combustible at elevated pressures. These mixtures, if ignited, may cause injury or property damage. Additional health and safety information may be obtained from refrigerant manufacturers.**

Refrigerant Connection

INFOID:000000006258618

A new type refrigerant connection has been introduced to all refrigerant lines except the following locations.

- Expansion valve to evaporator
- Refrigerant pressure sensor to liquid tank

O-RING AND REFRIGERANT CONNECTION

PRECAUTIONS

< PRECAUTION >

[WITH 7 INCH DISPLAY]

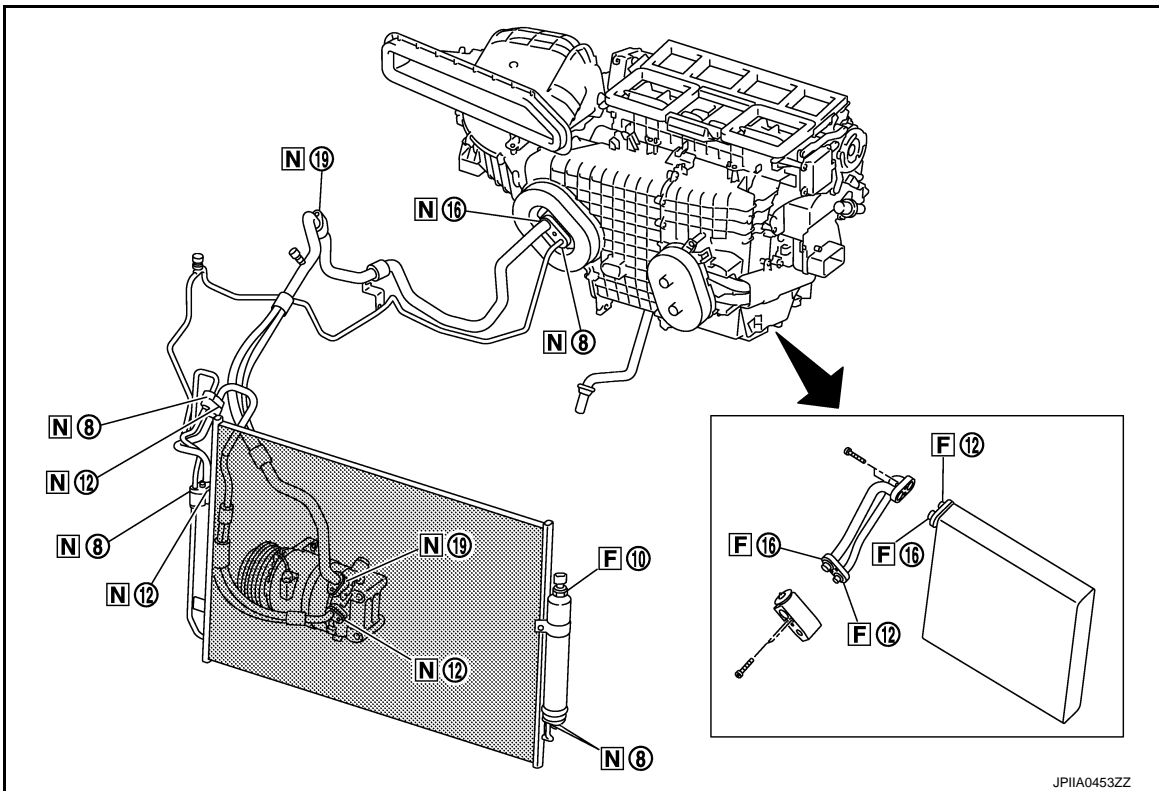

F. Former type refrigerant connection N. New type refrigerant connection
 O: O-ring size

CAUTION:

The new and former refrigerant connections use different O-ring configurations. Never confuse O-rings since they are not interchangeable. Refrigerant may leak at the connection if an incorrect O-ring is installed.

O-Ring Part Numbers and Specifications

Connection type	Piping connection point		Part number	QTY	O-ring size
New	Low-pressure flexible hose to low-pressure pipe		92474 N8210	1	φ19
	High-pressure pipe to condenser pipe assembly (Outlet)		92471 N8210	1	φ8
	Condenser pipe assembly (Inlet) to high-pressure flexible hose (One-touch joint)		92472 N8210	1	φ12
	Condenser assembly to condenser pipe assembly	Inlet	92472 N8210	1	φ12
		Outlet	92471 N8210	1	φ8
	Low-pressure pipe to expansion valve		92473 N8210	1	φ16
	High-pressure pipe to expansion valve		92471 N8210	1	φ8
	Compressor to low-pressure flexible hose		92474 N8210	1	φ19
	Compressor to high-pressure flexible hose		92472 N8210	1	φ12
Liquid tank to condenser assembly	Inlet	92471 N8210	1	φ8	
	Outlet		1		
Former	Refrigerant pressure sensor to liquid tank		J2476 89956	1	φ10
	Expansion valve to evaporator pipe assembly	Inlet	92475 71L00	1	φ12
		Outlet	92475 72L00	1	φ16
	Evaporator to evaporator pipe assembly	Inlet	92475 71L00	1	φ12
Outlet		92475 72L00	1	φ16	

A
B
C
D
E
F
G
H

VTL

J
K
L
M
N
O
P

PRECAUTIONS

< PRECAUTION >

[WITH 7 INCH DISPLAY]

WARNING:

Check that all refrigerant is discharged into the recycling equipment and the pressure in the system is less than the atmospheric pressure. Then gradually loosen the discharge side hose fitting and remove it.

CAUTION:

Observe the following items when replacing or cleaning refrigerant cycle components.

- Store it in the same way as it is when mounted on the car when the compressor is removed. Failure to do so will cause lubricant to enter the low-pressure chamber.
- Always use a torque wrench and a back-up wrench when connecting tubes.
- Immediately plug all openings to prevent entry of dust and moisture after disconnecting tubes.
- Connect the pipes at the final stage of the operation when installing an air conditioner in the vehicle. Never remove the seal caps of pipes and other components until just before they are required for connection.
- Allow components stored in cool areas to warm to working area temperature before removing seal caps. This prevents condensation from forming inside A/C components.
- Thoroughly remove moisture from the refrigeration system before charging the refrigerant.
- Always replace used O-rings.
- Apply lubricant to the circle of the O-rings shown in illustration when a connecting tube. Never apply lubricant to threaded portion.

Name : NISSAN A/C System Oil Type S

- O-ring must be closely attached to the groove portion of tube.
- Never damage O-ring and tube when replacing the O-ring.
- Connect tube until a click can be heard. Then tighten the nut or bolt by hand. Check that the O-ring is installed to the tube correctly.
- Perform leakage test and check that there is no leakage from connections after connecting the line. Disconnect the line and replace the O-ring when the refrigerant leakage point is found. Then tighten the connections of seal seat to the specified torque.

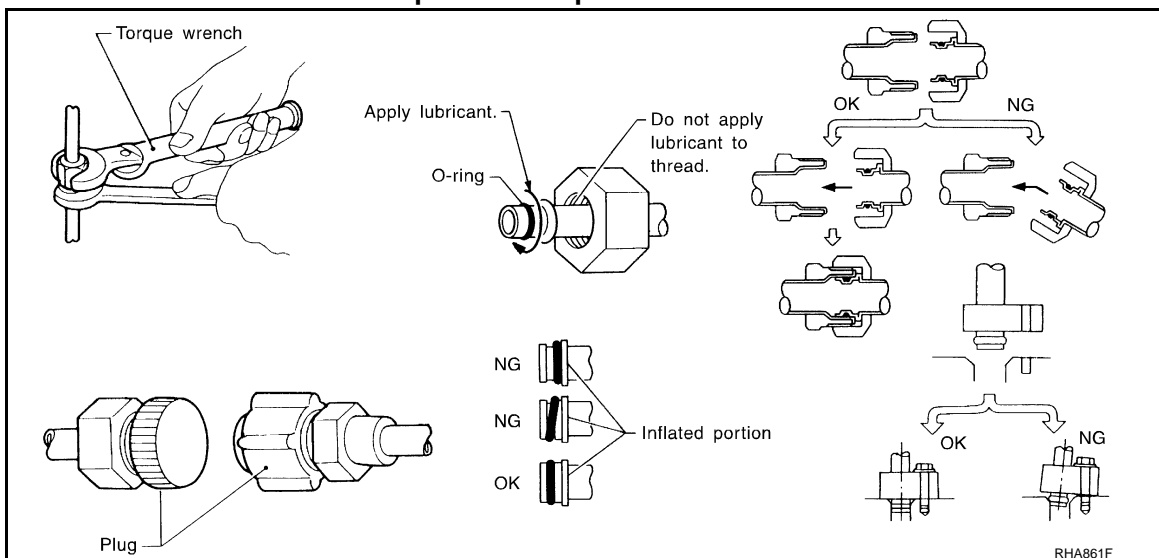

Service Equipment

INFOID:000000006258619

RECOVERY/RECYCLING EQUIPMENT

Be certain to follow the manufacturer instructions for machine operation and machine maintenance. Never introduce any refrigerant other than that specified into the machine.

ELECTRICAL LEAK DETECTOR

Be certain to follow the manufacturer instructions for tester operation and tester maintenance.

VACUUM PUMP

PRECAUTIONS

< PRECAUTION >

The lubricant contained inside the vacuum pump is not compatible with the specified lubricant for HFC-134a (R-134a) A/C systems. The vent side of the vacuum pump is exposed to atmospheric pressure. So the vacuum pump lubricant may migrate out of the pump into the service hose. This is possible when the pump is switched OFF after evacuation (vacuuming) and the hose is connected to it. To prevent this migration, use a manual valve placed near the hose-to-pump connection, as per the following procedure.

- Vacuum pumps usually have a manual isolator valve as part of the pump. Close this valve to isolate the service hose from the pump.
- Use a hose equipped with a manual shut-off valve near the pump end for pumps without an isolator. Close the valve to isolate the hose from the pump.
- Disconnect the hose from the pump if the hose has an automatic shut-off valve. As long as the hose is connected, the valve is open and lubricating oil may migrate.

Some one-way valves open when vacuum is applied and close under the no vacuum condition. Such valves may restrict the ability of the pump to create a deep vacuum and are not recommended.

[WITH 7 INCH DISPLAY]

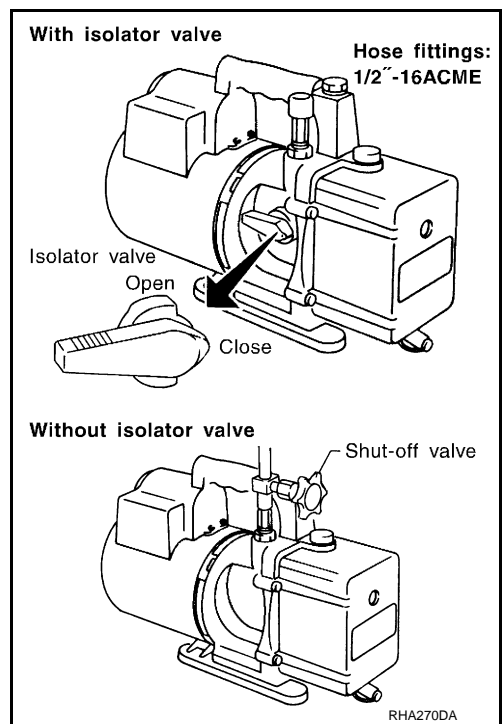

MANIFOLD GAUGE SET

Be certain that the gauge face indicates HFC-134a or R-134a. Be sure the gauge set has 1/2"-16 ACME threaded connections for service hoses. Confirm the set has been used only with refrigerant HFC-134a (R-134a) and specified lubricants.

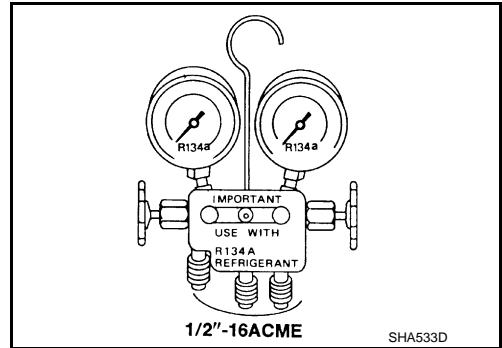

SERVICE HOSES

Be certain that the service hoses display the markings described (colored hose with a black stripe). All hoses must equip positive shut-off devices (either manual or automatic) near the end of the hoses opposite to the manifold gauge.

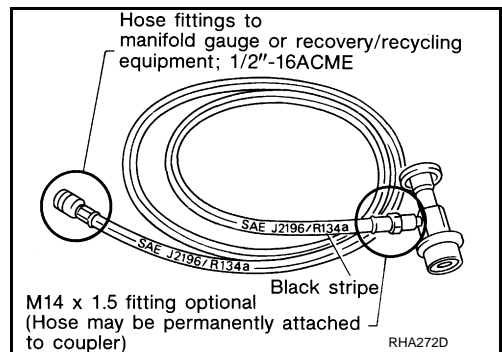

SERVICE COUPLERS

A
B
C
D
E
F
G
H
VTL
J
K
L
M
N
O
P

PRECAUTIONS

< PRECAUTION >

Never attempt to connect HFC-134a (R-134a) service couplers to a CFC-12 (R-12) A/C system. The HFC-134a (R-134a) couplers do not properly connect to the CFC-12 (R-12) system. However, if an improper connection is attempted, discharging and contamination may occur.

Shut-off valve rotation	A/C service valve
Clockwise	Open
Counterclockwise	Close

[WITH 7 INCH DISPLAY]

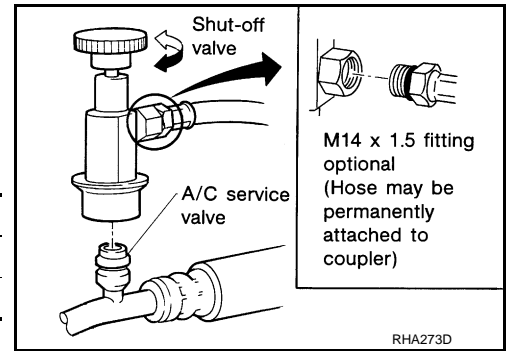

REFRIGERANT WEIGHT SCALE

Verify that no refrigerant other than HFC-134a (R-134a) and specified lubricants have been used with the scale. The hose fitting must be 1/2"-16 ACME if the scale controls refrigerant flow electronically.

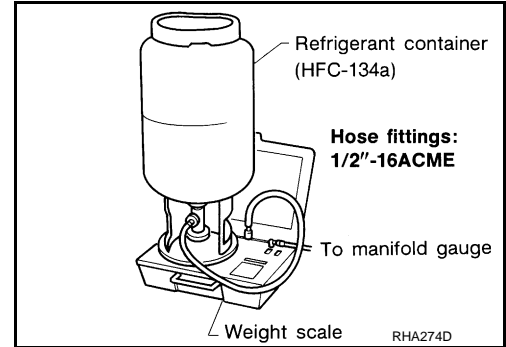

CHARGING CYLINDER

Use of a charging cylinder is not recommended. Refrigerant may be vented into the air from the top valve of the cylinder when filling the cylinder with refrigerant. Also, the accuracy of the cylinder is generally less than that of an electronic scale or of quality recycle/recharge equipment.

COMPRESSOR

General Precautions

INFOID:000000006258620

CAUTION:

- Plug all openings to prevent moisture and foreign material from entering.
- Store it in the same way as it is when mounted on the car when the compressor is removed.
- Follow “Maintenance of Lubricant Quantity in Compressor” exactly when replacing or repairing compressor. Refer to [HA-25, "Maintenance of Lubricant Quantity"](#).
- Keep friction surfaces between clutch and pulley clean. Wipe it off by using a waste moistened with thinner if the surface is contaminated with lubricant.
- Turn the compressor shaft by hand more than five turns in both directions after compressor service operation. This equally distributes lubricant inside the compressor. Let the engine idle and operate the compressor for one hour after the compressor is installed.
- Apply voltage to the new compressor and check for normal operation after replacing the compressor magnet clutch.

A
B
C
D
E
F
G
H
VTL
J
K
L
M
N
O
P

FLUORESCENT LEAK DETECTOR

< PRECAUTION >

[WITH 7 INCH DISPLAY]

FLUORESCENT LEAK DETECTOR

General Precautions

INFOID:000000006258621

CAUTION:

- The A/C system contains a fluorescent leak detection dye used for locating refrigerant leakages. An ultraviolet (UV) lamp is required to illuminate the dye when inspecting for leakages.
- Always wear fluorescence enhancing UV safety goggles to protect eyes and enhance the visibility of the fluorescent dye.
- The fluorescent dye leak detector is not a replacement for an electrical leak detector (SST: J-41995). The fluorescent dye leak detector should be used in conjunction with an electrical leak detector (SST: J-41995) to pin-point refrigerant leakages.
- Read and follow all manufacturer operating instructions and precautions prior to performing work for safety and customer satisfaction.
- A compressor shaft seal should not necessarily be repaired because of dye seepage. The compressor shaft seal should only be repaired after confirming the leakage with an electrical leak detector (SST: J-41995).
- Always remove any remaining dye from the leakage area after repairs are completed to avoid a misdiagnosis during future service.
- Never allow dye to come into contact with painted body panels or interior components. Immediately clean with the approved dye cleaner if dye is spilled. Fluorescent dye left on a surface for an extended period of time cannot be removed.
- Never spray fluorescent dye cleaning agent on hot surfaces (engine exhaust manifold, etc.).
- Never use more than one refrigerant dye bottle [1/4 ounce (7.4 cc)] per A/C system.
- Leak detection dyes for HFC-134a (R-134a) and CFC-12 (R-12) A/C systems are different. Never use HFC-134a (R-134a) leak detection dye in CFC-12 (R-12) A/C system or CFC-12 (R-12) leak detection dye in HFC-134a (R-134a) A/C system, otherwise A/C system damage may result.
- The fluorescent properties of the dye remains for three or more years unless a compressor malfunction occurs.

IDENTIFICATION

NOTE:

Vehicles with factory installed fluorescent dye have a green label.

Vehicles without factory installed fluorescent dye have a blue label.

IDENTIFICATION LABEL FOR VEHICLE

Vehicles with factory installed fluorescent dye have an identification label on the front side of hood.

PREPARATION

PREPARATION

Special Service Tool

INFOID:000000006258622

The actual shapes of Kent-Moore tools may differ from those of special service tools illustrated here.

HFC-134a (R-134a) Service Tool and Equipment



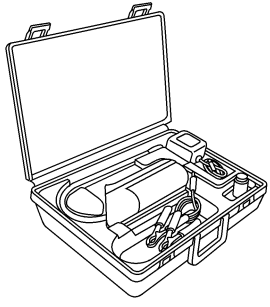
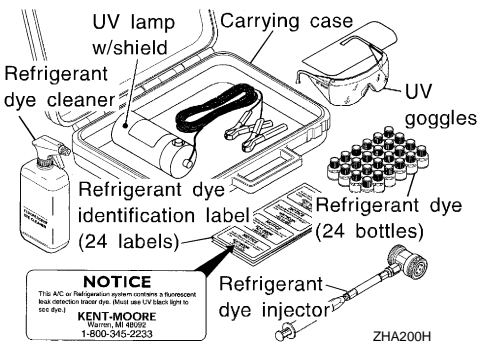

- Never mix HFC-134a (R-134a) refrigerant and/or its specified lubricant with CFC-12 (R-12) refrigerant and/or its lubricant.
- Separate and non-interchangeable service equipment must be used for handling each type of refrigerant/lubricant.
- Refrigerant container fittings, service hose fittings and service equipment fittings (equipment that handles refrigerant and/or lubricant) are different between CFC-12 (R-12) and HFC-134a (R-134a). This is to avoid mixed use of the refrigerants/lubricant.
- Never use adapters that convert one size fitting to another. Refrigerant/lubricant contamination occurs and compressor malfunction may result.

Tool number (Kent-Moore No.) Tool name	Description
<p>(ACR2005-NI) ACR5 A/C Service Center</p>  <p style="text-align: right; font-size: small;">WJIA0293E</p>	<p>Function: Refrigerant recovery, recycling and recharging</p>
<p>(J-41995) Electrical leak detector</p>  <p style="text-align: right; font-size: small;">AHA281A</p>	<p>Power supply: DC 12 V (Battery terminal)</p>
<p>(J-43926) Refrigerant dye leak detection kit Kit includes: (J-42220) UV lamp and UV safety goggles (J-41459) HFC-134a (R-134a) dye injector Use with J-41447, 1/4 ounce bottle (J-41447) HFC-134a (R-134a) fluorescent leak detection dye (Box of 24, 1/4 ounce bottles) (J-43872) Refrigerant dye cleaner</p>  <p style="text-align: right; font-size: small;">ZHA200H</p>	<p>Power supply: DC 12 V (Battery terminal)</p>

PREPARATION

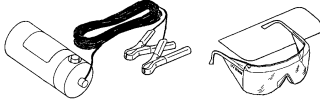
< PREPARATION >

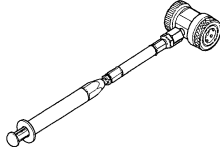
[WITH 7 INCH DISPLAY]

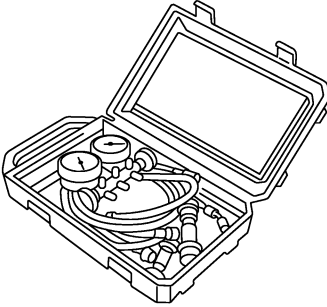
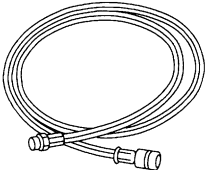
Tool number (Kent-Moore No.) Tool name	Description
<p>(J-42220) UV lamp and UV safety goggles</p>  <p style="text-align: center;">SHA438F</p>	<p>Power supply: DC 12 V (Battery terminal) For checking refrigerant leakage when fluorescent dye is equipped in A/C system Includes: UV lamp and UV safety goggles</p>
<p>(J-41447) HFC-134a (R-134a) fluorescent leak detection dye (Box of 24, 1/4 ounce bottles)</p>  <p style="text-align: center;">Refrigerant dye (24 bottles) SHA439F</p>	<p>Application: For HFC-134a (R-134a) PAG oil Container: 1/4 ounce (7.4 cc) bottle (Includes self-adhesive dye identification labels for affixing to vehicle after charging system with dye.)</p>
<p>(J-41459) HFC-134a (R-134a) dye injector Use with J-41447, 1/4 ounce bottle</p>  <p style="text-align: center;">SHA440F</p>	<p>For injecting 1/4 ounce of fluorescent leak detection dye into A/C system</p>
<p>(J-43872) Refrigerant dye cleaner</p>  <p style="text-align: center;">SHA441F</p>	<p>For cleaning dye spills</p>
<p>(J-39183) Manifold gauge set (with hoses and couplers)</p>  <p style="text-align: center;">RJIA0196E</p>	<p>Identification:</p> <ul style="list-style-type: none"> The gauge face indicates HFC-134a (R-134a). <p>Fitting size: Thread size</p> <ul style="list-style-type: none"> 1/2" -16 ACME
<p>Service hoses</p> <ul style="list-style-type: none"> High-pressure side hose (J-39501-72) Low-pressure side hose (J-39502-72) Utility hose (J-39476-72)  <p style="text-align: center;">S-NT201</p>	<p>Hose color:</p> <ul style="list-style-type: none"> Low-pressure side hose: Blue with black stripe High-pressure side hose: Red with black stripe Utility hose: Yellow with black stripe or green with black stripe <p>Hose fitting to gauge:</p> <ul style="list-style-type: none"> 1/2" -16 ACME

PREPARATION

< PREPARATION >

[WITH 7 INCH DISPLAY]

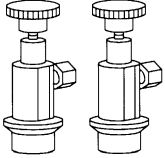
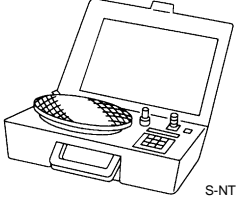
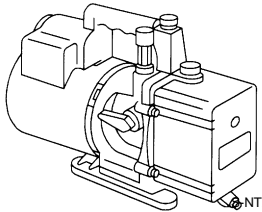
Tool number (Kent-Moore No.) Tool name	Description
<p>Service couplers</p> <ul style="list-style-type: none"> • High-pressure side coupler (J-39500-20) • Low-pressure side coupler (J-39500-24)  <p style="text-align: center;">S-NT202</p>	<p>Hose fitting to service hose: M14 x 1.5 fitting is optional or permanently attached.</p>
<p>(J-39650) Refrigerant weight scale</p>  <p style="text-align: center;">S-NT200</p>	<p>For measuring of refrigerant Fitting size: Thread size 1/2"-16 ACME</p>
<p>(J-39649) Vacuum pump (Including the isolator valve)</p>  <p style="text-align: center;">S-NT203</p>	<p>Capacity:</p> <ul style="list-style-type: none"> • Air displacement: 4 CFM • Micron rating: 20 microns • Oil capacity: 482 g (17 oz.) <p>Fitting size: Thread size</p> <ul style="list-style-type: none"> • 1/2"-16 ACME

Commercial Service Tool

INFOID:000000006258623

VTL

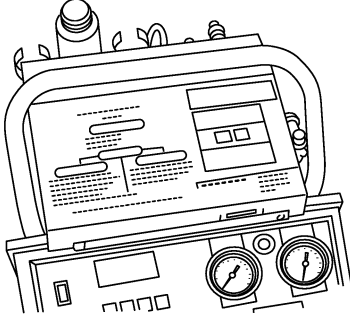
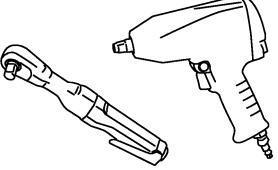
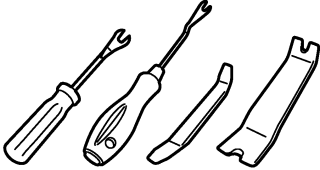
Tool name	Description
<p>Refrigerant identifier equipment</p>  <p style="text-align: center;">RJIA0197E</p>	<p>Checking for refrigerant purity and system contamination</p>
<p>Power tools</p>  <p style="text-align: center;">PBIC0190E</p>	<p>For loosening bolts and nuts</p>
<p>Remover tools</p>  <p style="text-align: center;">JMKIA3050ZZ</p>	<p>Remove clips, pawls, and metal clips</p>

PREPARATION

< PREPARATION >



[WITH 7 INCH DISPLAY]

Sealant or/and Lubricant

INFOID:000000006258624

HFC-134a (R-134a) Service Tool and Equipment

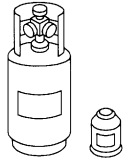
- Never mix HFC-134a (R-134a) refrigerant and/or its specified lubricant with CFC-12 (R-12) refrigerant and/or its lubricant.
- Separate and non-interchangeable service equipment must be used for handling each type of refrigerant/lubricant.
- Refrigerant container fittings, service hose fittings and service equipment fittings (equipment that handles refrigerant and/or lubricant) are different between CFC-12 (R-12) and HFC-134a (R-134a). This is to avoid mixed use of the refrigerants/lubricant.
- Never use adapters that convert one size fitting to another. Refrigerant/lubricant contamination occurs and compressor malfunction may result.

Tool name	Description
<p>HFC-134a (R-134a) refrigerant</p>  <p>S-NT196</p>	<p>Container color: Light blue Container marking: HFC-134a (R-134a) Fitting size: Thread size</p> <ul style="list-style-type: none">• Large container 1/2" -16 ACME
<p>NISSAN A/C System Oil Type S (DH-PS)</p>  <p>S-NT197</p>	<p>Type: Polyalkylene glycol oil (PAG), type S (DH-PS) Application: HFC-134a (R-134a) swash plate compressors (NISSAN only) Capacity: 40 mℓ (1.4 US fl oz., 1.4 Imp fl oz.)</p>

PERIODIC MAINTENANCE

IN-CABIN MICROFILTER

Exploded View

INFOID:000000006258625

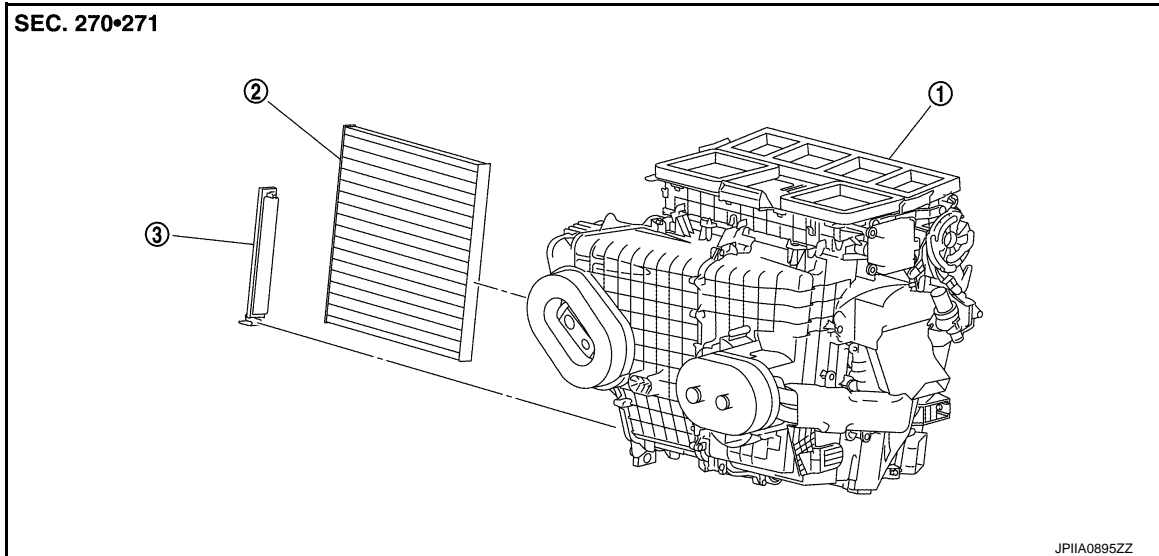

1. Heater & cooling unit assembly 2. In-cabin microfilter/Air conditioner filter* 3. Filter cover

* : Models for Mexico.

A
B
C
D
E
F
G
H

VTL

Removal and Installation

INFOID:000000006258626

REMOVAL

1. Remove the filter cover (1), and then remove the in-cabin microfilter/air conditioner filter (2).

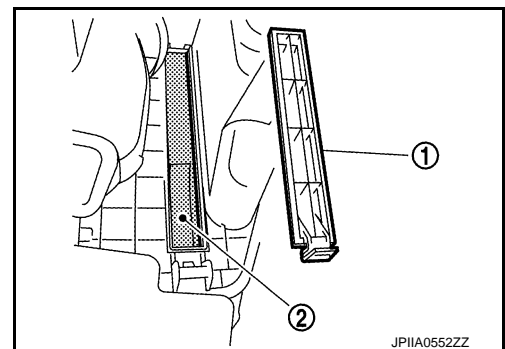

INSTALLATION

Install in the reverse order of removal.

CAUTION:

- If the filter is deformed/damaged when removing, replace it with a new one. Deformed/damaged filter may deteriorate the dust collecting performance.
- When installing, handle the filter with extreme care to avoid deforming/damaging.

Replacement

INFOID:000000006258627

Replace in-cabin microfilter/air conditioner filter.

For NORTH AMERICA : Refer to [MA-8, "FOR NORTH AMERICA : Schedule 1"](#) and [MA-10, "FOR NORTH AMERICA : Schedule 2"](#).

For MEXICO : Refer to [MA-11, "FOR MEXICO : Periodic Maintenance"](#).

Affix a caution label inside the glove box when replacing filter.

J
K
L
M
N
O
P

PRESET SWITCH

< REMOVAL AND INSTALLATION >

[WITH 7 INCH DISPLAY]

REMOVAL AND INSTALLATION

PRESET SWITCH

Exploded View

INFOID:000000006258628

DISASSEMBLY

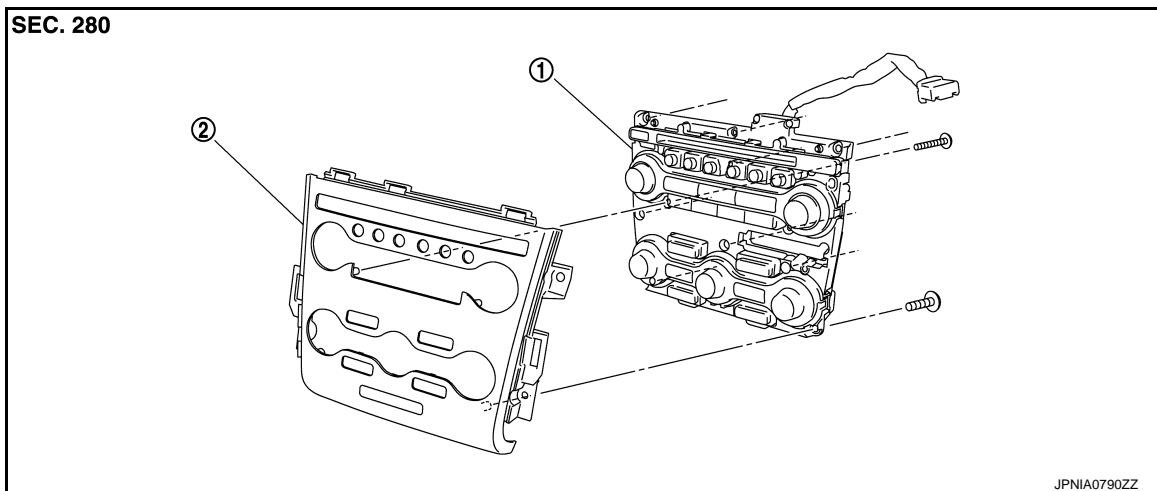

1. Preset switch

2. Cluster lid C

Removal and Installation

INFOID:000000006258629

REMOVAL

Remove the preset switch. Refer to [AV-283, "Exploded View"](#) (Bose audio without navigation) or [AV-428, "Exploded View"](#) (Bose audio with navigation).

INSTALLATION

Install in the reverse order of removal.

A/C AUTO AMP.

< REMOVAL AND INSTALLATION >

[WITH 7 INCH DISPLAY]

A/C AUTO AMP.

Exploded View

INFOID:000000006258630

DISASSEMBLY

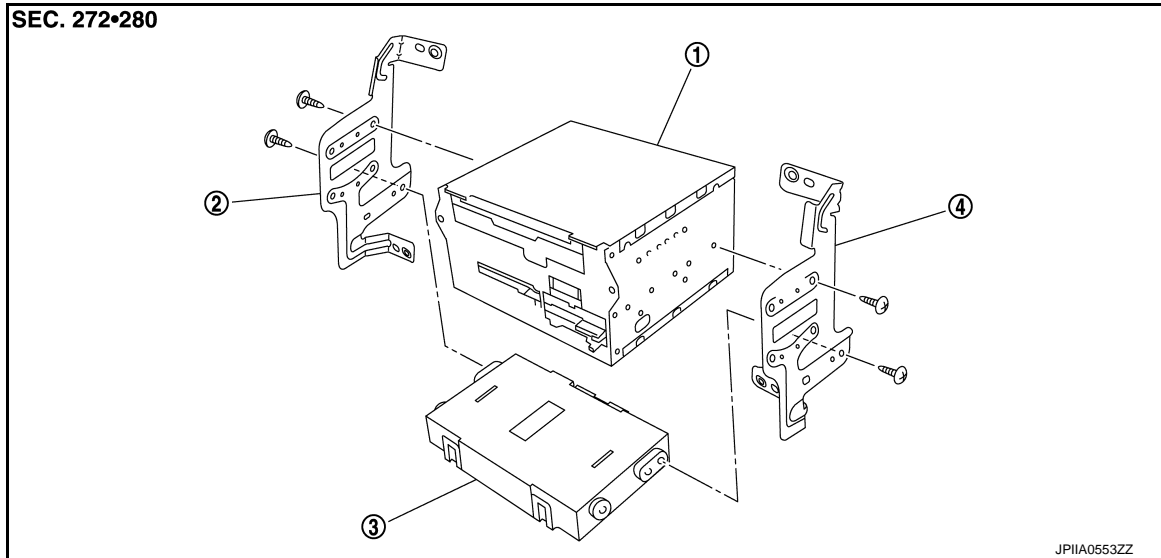

- 1. AV control unit
- 2. Bracket (LH)
- 3. A/C auto amp.
- 4. Bracket (RH)

Removal and Installation

INFOID:000000006258631

REMOVAL

1. Remove the AV control unit. Refer to [AV-145. "Exploded View"](#).
2. Remove the mounting screws (A), and then remove the A/C auto amp. (1).

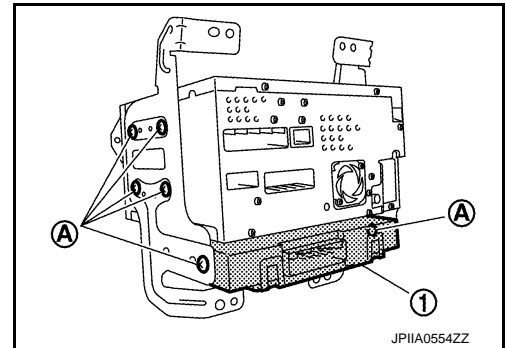

INSTALLATION

Install in the reverse order of removal.

AMBIENT SENSOR

< REMOVAL AND INSTALLATION >

[WITH 7 INCH DISPLAY]

AMBIENT SENSOR

Exploded View

INFOID:000000006258632

1. Ambient sensor

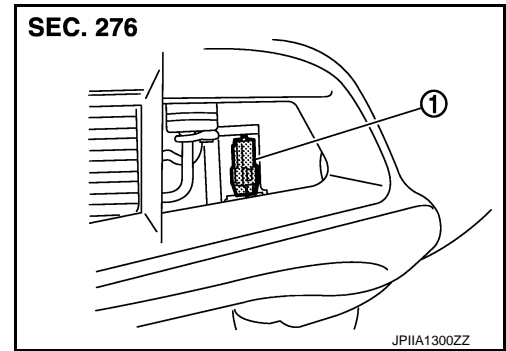

Removal and Installation

INFOID:000000006258633

REMOVAL

1. Disconnect the ambient sensor connector (A), and then remove the ambient sensor (1).

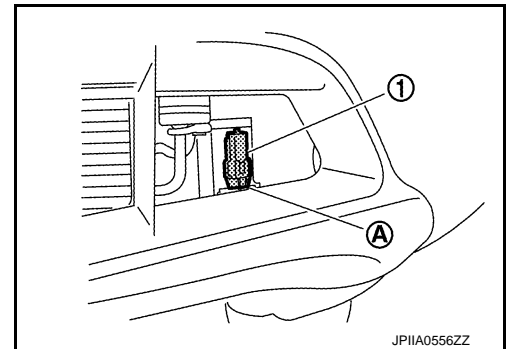

INSTALLATION

Install in the reverse order of removal.

IN-VEHICLE SENSOR

< REMOVAL AND INSTALLATION >

[WITH 7 INCH DISPLAY]

IN-VEHICLE SENSOR

Exploded View

INFOID:000000006258634

1. In-vehicle sensor
2. Instrument lower panel LH

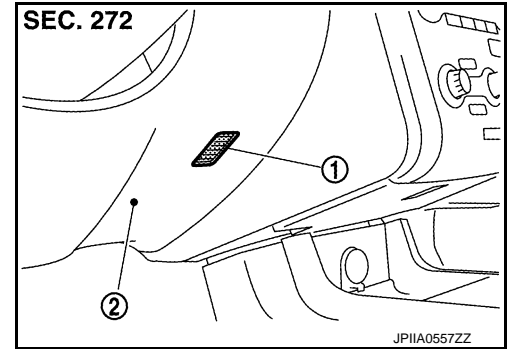

Removal and Installation

INFOID:000000006258635

REMOVAL

1. Remove the instrument lower panel LH. Refer to [IP-12, "Exploded View"](#).
2. Remove the mounting screw (A), and then remove the in-vehicle sensor (1).

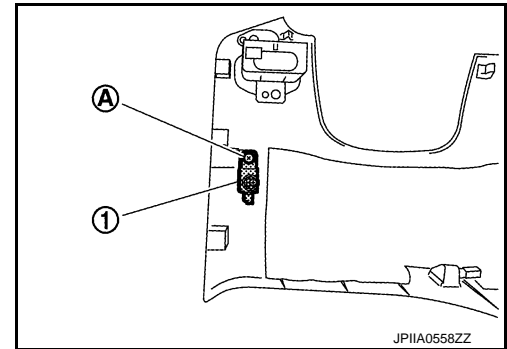

INSTALLATION

Install in the reverse order of removal.

A
B
C
D
E
F
G
H
VTL
J
K
L
M
N
O
P

SUNLOAD SENSOR

< REMOVAL AND INSTALLATION >

[WITH 7 INCH DISPLAY]

SUNLOAD SENSOR

Exploded View

INFOID:000000006258636

1. Sunload sensor

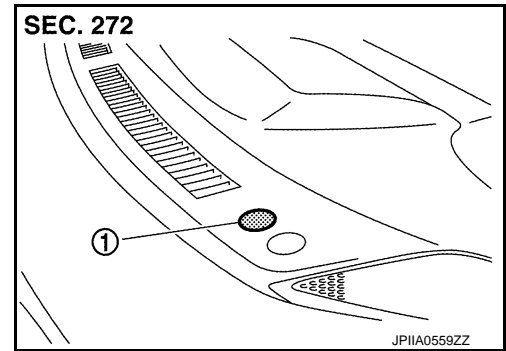

Removal and Installation

INFOID:000000006258637

REMOVAL

1. Disconnect the sunload sensor connector, and then remove the sunload sensor (1).

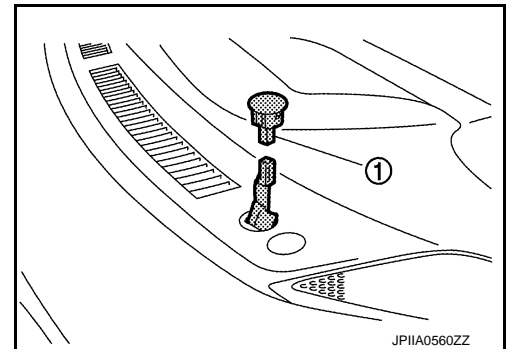

INSTALLATION

Install in the reverse order of removal.

INTAKE SENSOR

< REMOVAL AND INSTALLATION >

[WITH 7 INCH DISPLAY]

INTAKE SENSOR

Exploded View

INFOID:000000006258638

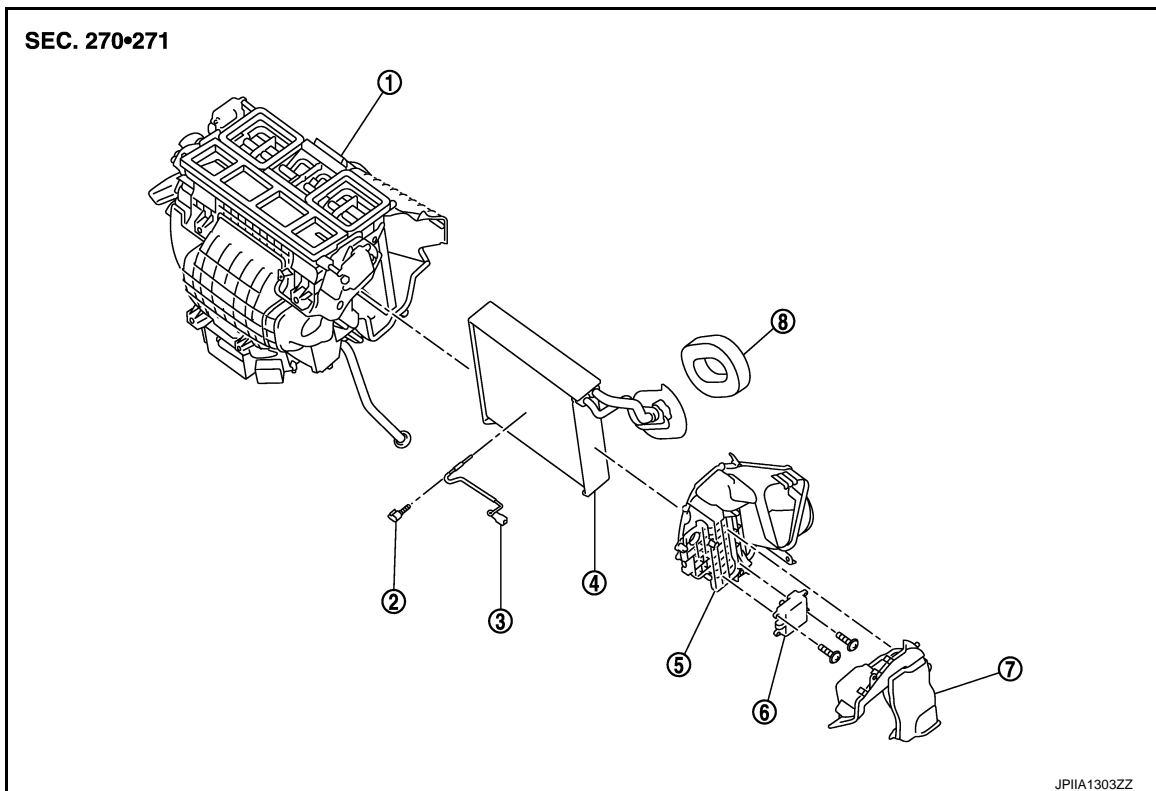

- | | | |
|-----------------------------------|--------------------------|--|
| 1. Heater & cooling unit assembly | 2. Intake sensor bracket | 3. Intake sensor |
| 4. Evaporator assembly | 5. Evaporator cover | 6. Air mix door motor (passenger side) |
| 7. Foot duct (right) | 8. Cooler pipe grummet | |

Removal and Installation

INFOID:000000006258639

REMOVAL

1. Remove the evaporator pipe assembly. Refer to [VTL-98, "Exploded View"](#).
2. Slide the evaporator (1) toward the right side of the vehicle, and then remove the intake sensor (2).

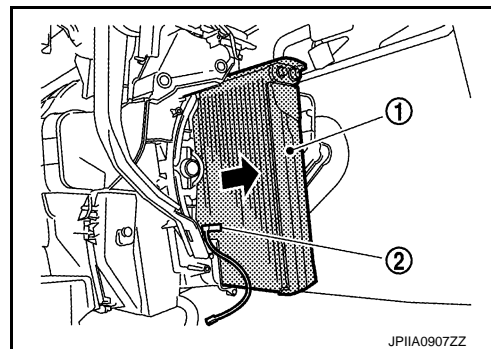

INSTALLATION

Note the following, and install in the reverse order of removal.

CAUTION:

- Replace the O-ring with a new one. Apply a coat of compressor oil to the O-ring prior to installation.
- Install the intake sensor in the same position as the removed intake sensor when replacing the intake sensor.
- Do not rotate the bracket insertion part when removing and installing the intake sensor.
- Check for refrigerant leakage when charging refrigerant.

BLOWER UNIT

< REMOVAL AND INSTALLATION >

[WITH 7 INCH DISPLAY]

BLOWER UNIT

Exploded View

INFOID:000000006258640

REMOVAL

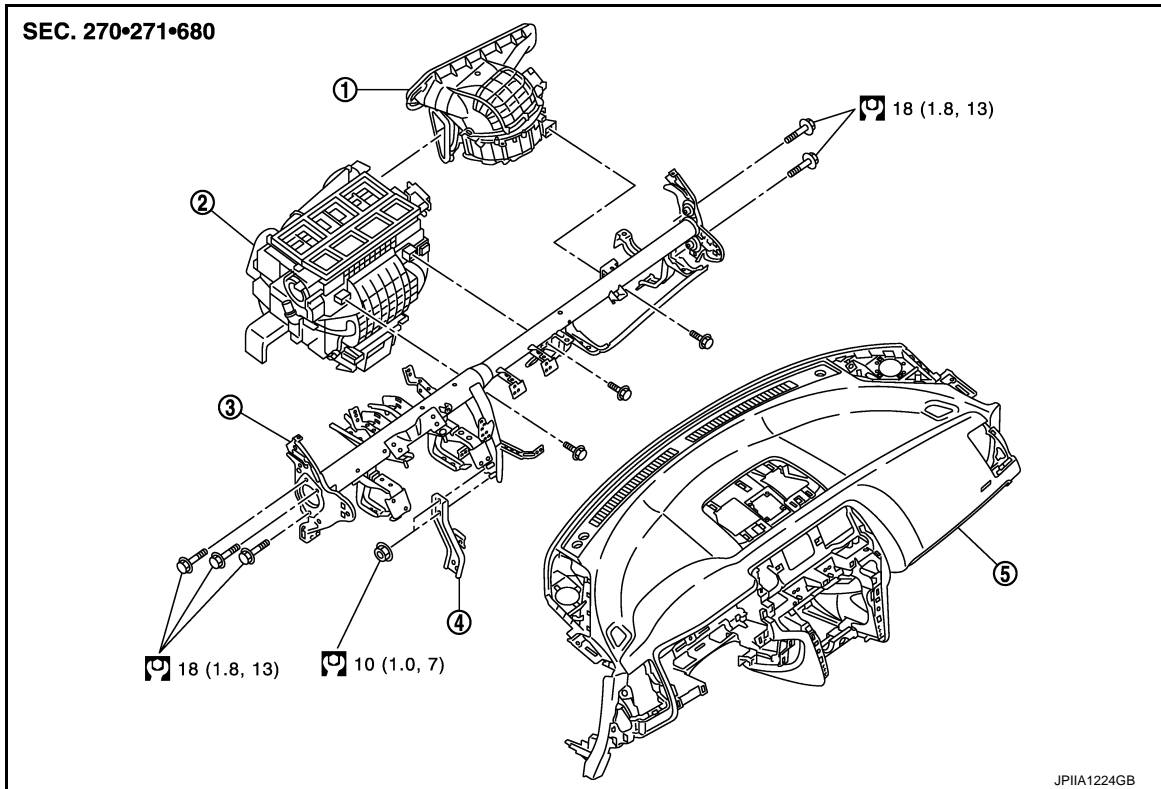

- | | | |
|-------------------------|-----------------------------------|--------------------|
| 1. Blower unit assembly | 2. Heater & cooling unit assembly | 3. Steering member |
| 4. Instrument stay | 5. Instrument panel assembly | |

Refer to [GI-4, "Components"](#) for symbols in the figure.

DISASSEMBLY

BLOWER UNIT

< REMOVAL AND INSTALLATION >

[WITH 7 INCH DISPLAY]

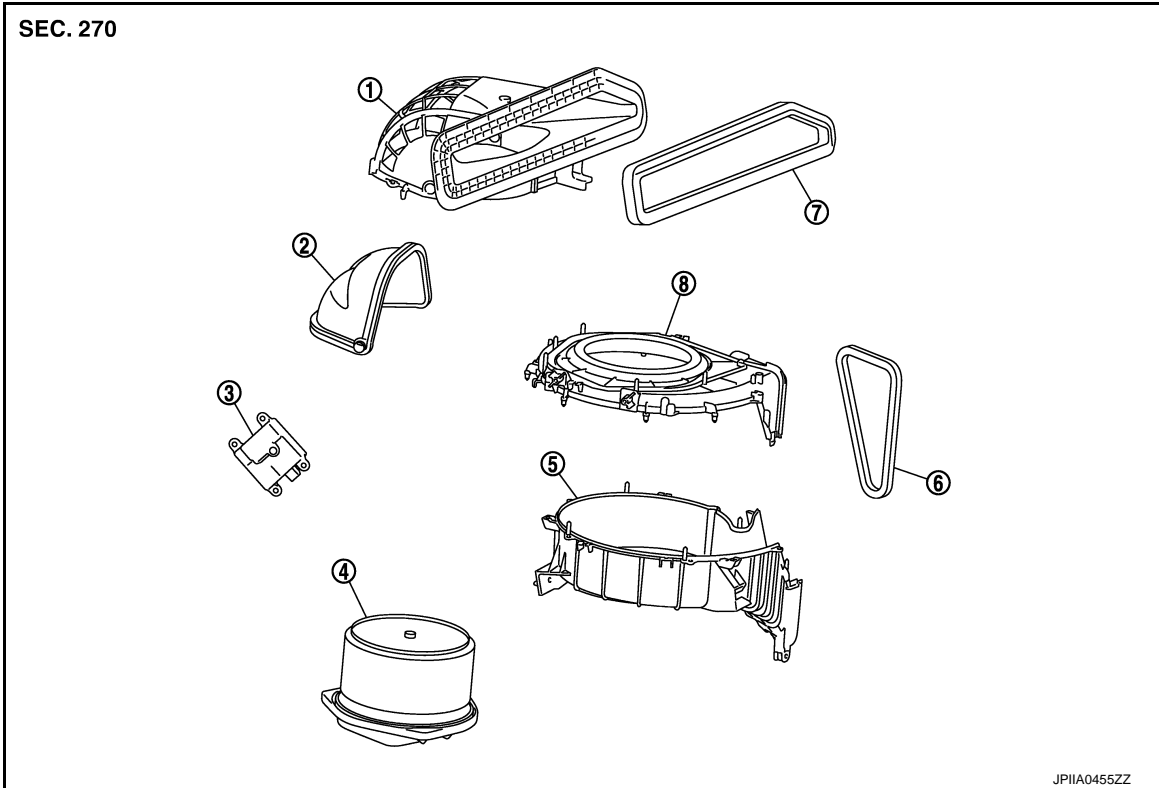

- | | | |
|--------------------------|----------------------|----------------------|
| 1. Shutter box case | 2. Intake door | 3. Intake door motor |
| 4. Blower motor assembly | 5. Intake lower case | 6. Outlet seal |
| 7. Intake seal | 8. Intake upper case | |

Removal and Installation

INFOID:000000006258641

REMOVAL

1. Remove the instrument panel assembly. Refer to [IP-12, "Exploded View"](#).
2. Remove the mounting nuts (A), and then remove the instrument panel stay (1).

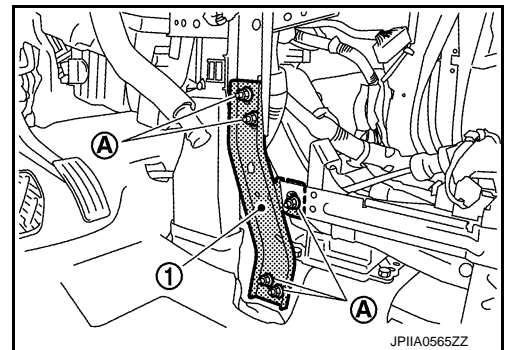

3. Disconnect the intake door motor and blower motor connectors.

BLOWER UNIT

< REMOVAL AND INSTALLATION >

[WITH 7 INCH DISPLAY]

4. Remove the heater & cooling unit assembly and blower unit mounting bolts (A).

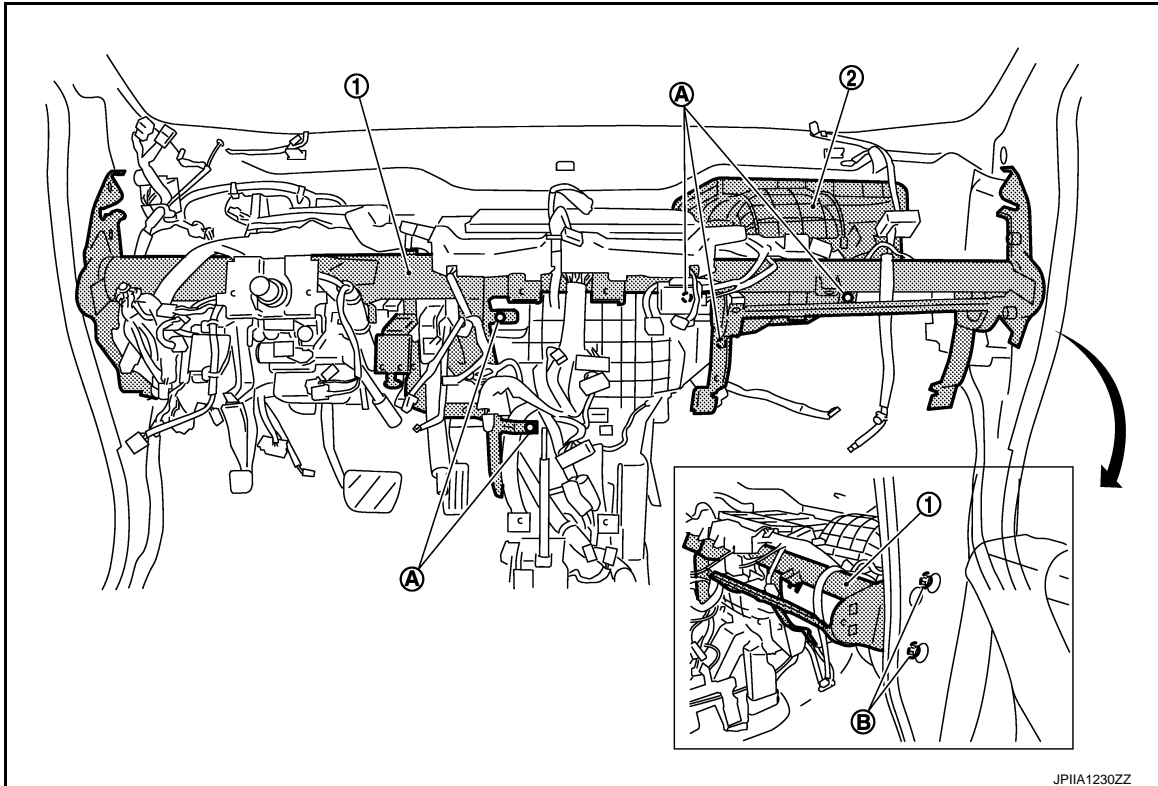

Refer to [GI-4. "Components"](#) for symbols in the figure.

5. Remove the steering member mounting bolts (B) (right).
6. And remove the blower unit (2) while pulling the steering member (1) to the front.

INSTALLATION

Install in the reverse order of removal.

BLOWER MOTOR

< REMOVAL AND INSTALLATION >

[WITH 7 INCH DISPLAY]

BLOWER MOTOR

Exploded View

INFOID:000000006258642

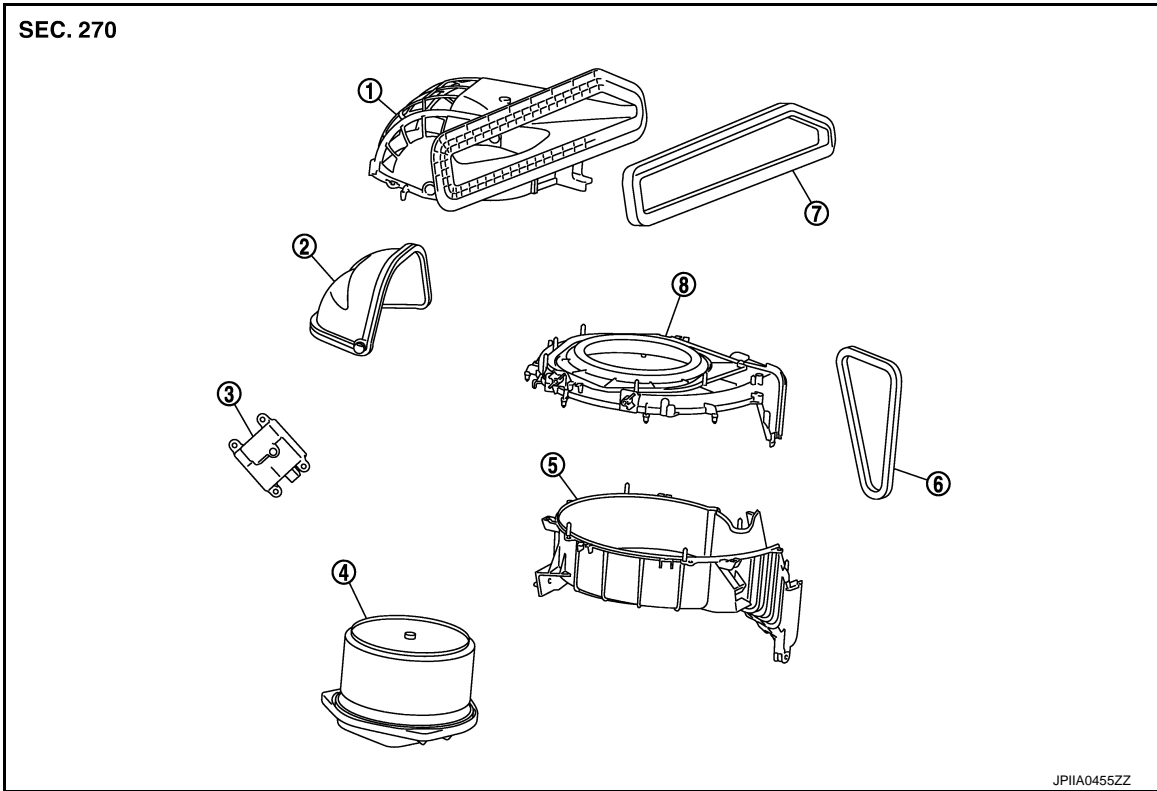

- | | | |
|--------------------------|----------------------|----------------------|
| 1. Shutter box case | 2. Intake door | 3. Intake door motor |
| 4. Blower motor assembly | 5. Intake lower case | 6. Outlet seal |
| 7. Intake seal | 8. Intake upper case | |

Removal and Installation

INFOID:000000006258643

REMOVAL

1. Remove instrument lower panel RH. Refer to [IP-12. "Exploded View"](#).
2. Disconnect the blower motor connector.
3. Remove the mounting screws (A), and then remove the blower motor (1).

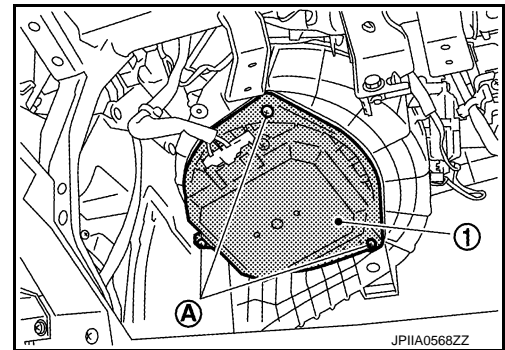

INSTALLATION

Install in the reverse order of removal.

INTAKE DOOR MOTOR

< REMOVAL AND INSTALLATION >

[WITH 7 INCH DISPLAY]

INTAKE DOOR MOTOR

Exploded View

INFOID:000000006258644

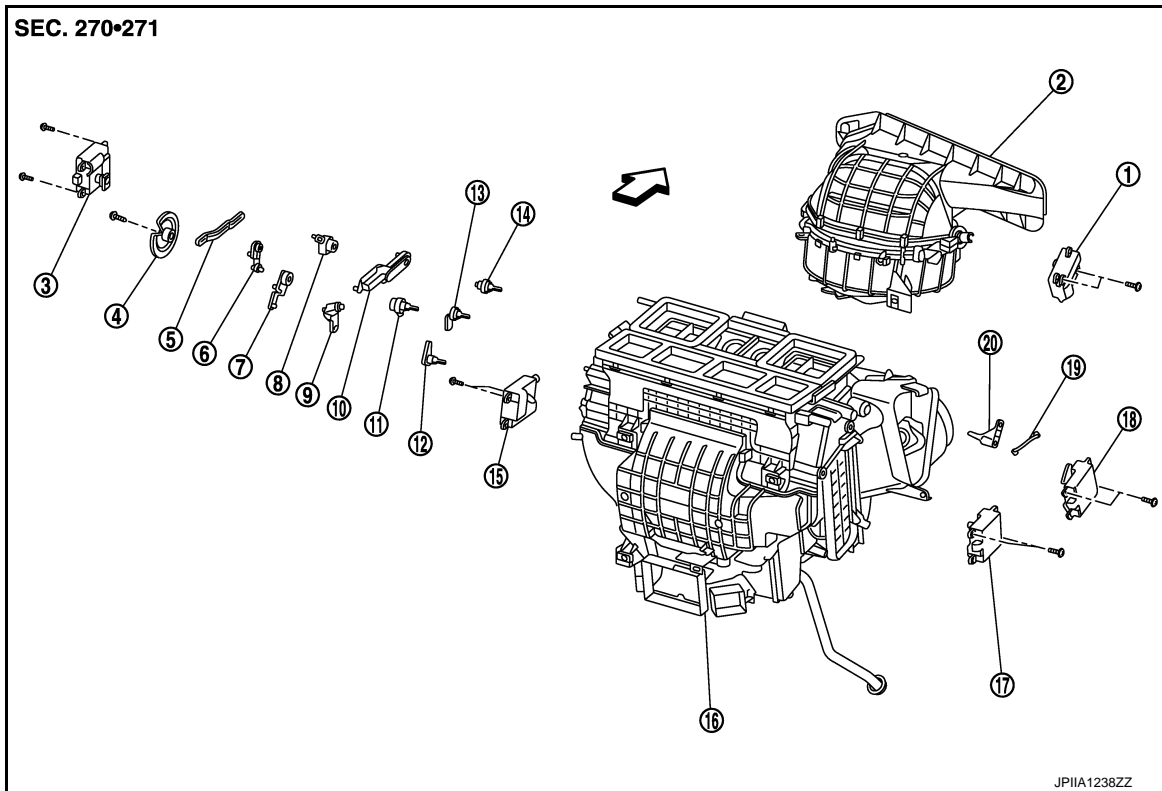

- | | | |
|------------------------------------|---|--------------------------------------|
| 1. Intake door motor | 2. Bower unit assembly | 3. Mode door motor |
| 4. Main link | 5. Rod link | 6. Max. cool door link |
| 7. Max. cool door link | 8. Mode door lever | 9. Ventilator door link |
| 10. Defroster door link | 11. Ventilator door lever | 12. Foot door lever |
| 13. Max. cool door lever | 14. Defroster door lever | 15. Air mix door motor (driver side) |
| 16. Heater & cooling unit assembly | 17. Air mix door motor (passenger side) | 18. Upper ventilator door motor |
| 19. Upper ventilator door rod | 20. Upper ventilator door lever | |

↔ : Vehicle front

Removal and Installation

INFOID:000000006258645

REMOVAL

1. Remove instrument lower panel RH. Refer to [IP-12, "Exploded View"](#).
2. Remove the mounting screw (A), and then move the key less controller assembly bracket (1) to a position where it does not inhibit work.

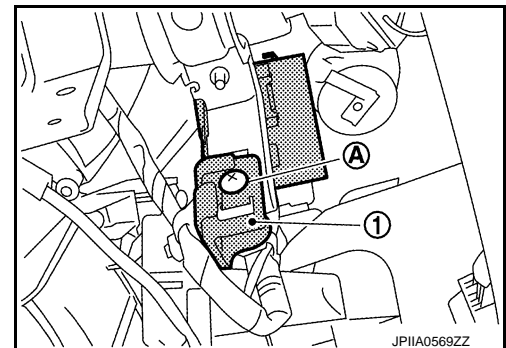

INTAKE DOOR MOTOR

< REMOVAL AND INSTALLATION >

[WITH 7 INCH DISPLAY]

3. Remove the mounting screws (A), and then remove the intake door motor (1).
4. Disconnect the intake door motor connector.

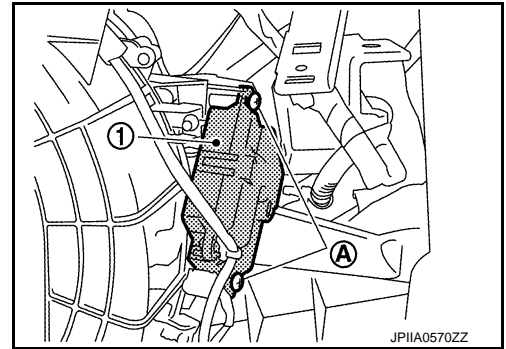

INSTALLATION

Install in the reverse order of removal.

A
B
C
D
E
F
G
H
J
K
L
M
N
O
P

VTL

HEATER & COOLING UNIT ASSEMBLY

< REMOVAL AND INSTALLATION >

[WITH 7 INCH DISPLAY]

HEATER & COOLING UNIT ASSEMBLY

Exploded View

INFOID:000000006258646

REMOVAL

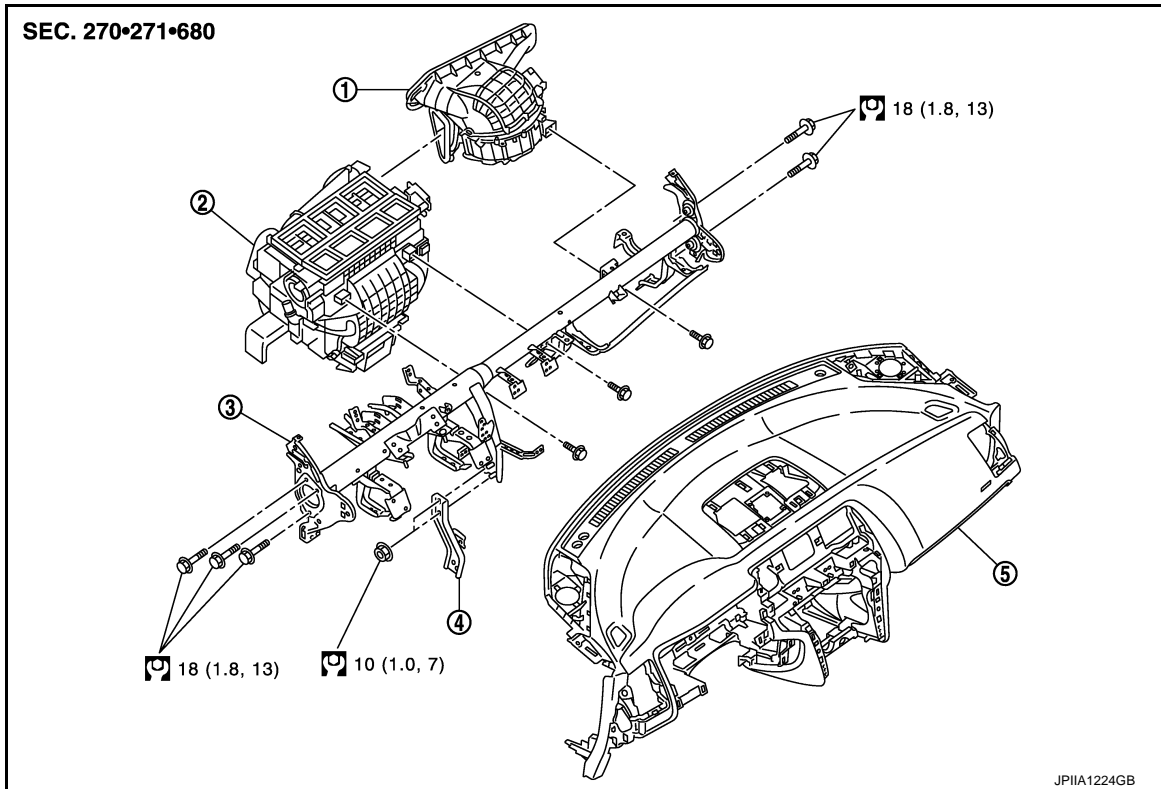

- | | | |
|-------------------------|-----------------------------------|--------------------|
| 1. Blower unit assembly | 2. Heater & cooling unit assembly | 3. Steering member |
| 4. Instrument stay | 5. Instrument panel assembly | |

Refer to [GI-4, "Components"](#) for symbols in the figure.

DISASSEMBLY

HEATER & COOLING UNIT ASSEMBLY

< REMOVAL AND INSTALLATION >

[WITH 7 INCH DISPLAY]

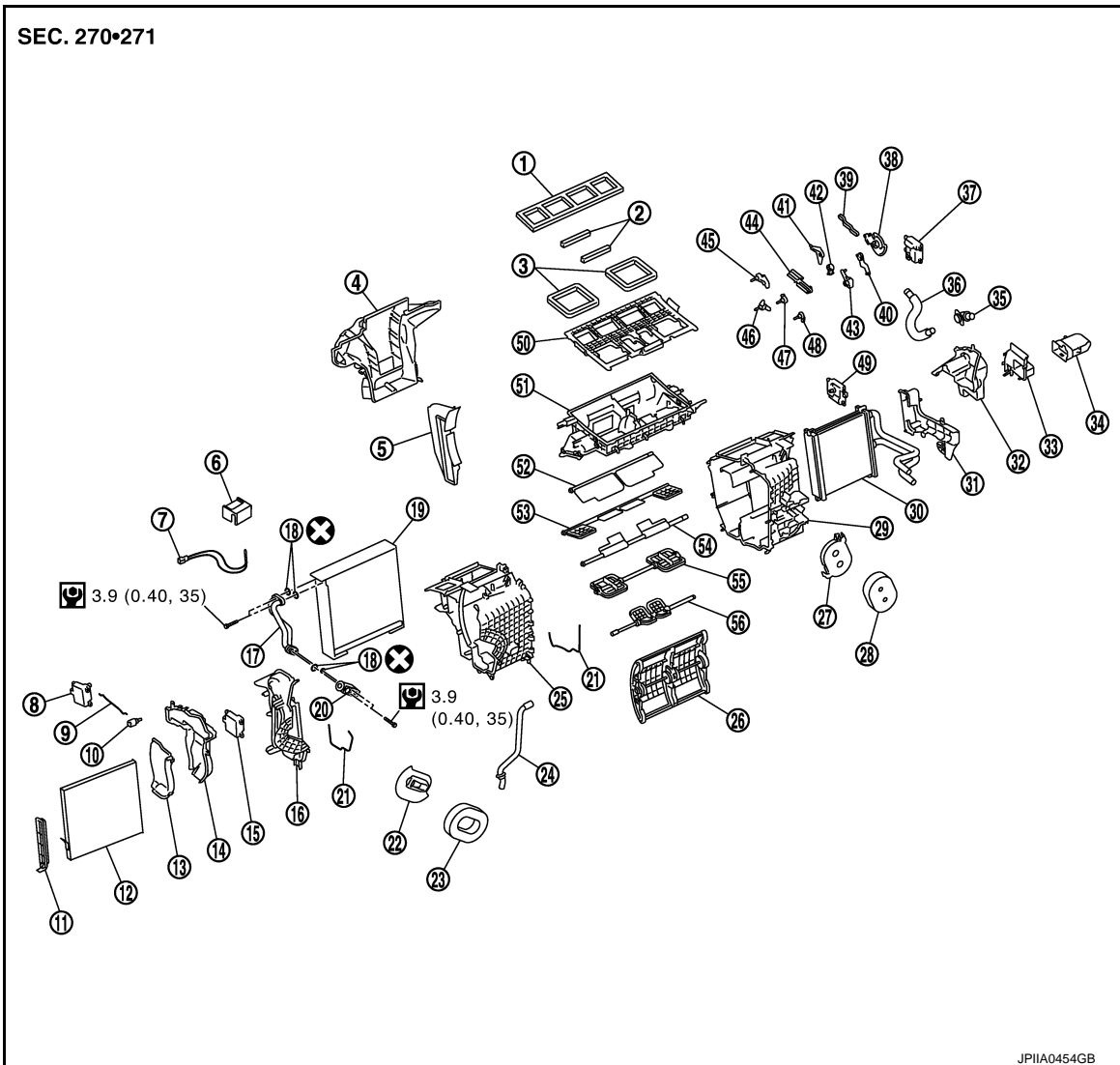

- | | | |
|--|---------------------------------------|--|
| 1. Ventilator seal | 2. Upper ventilator seal | 3. Defroster seal |
| 4. Adapter case | 5. Center case | 6. Intake sensor bracket |
| 7. Intake sensor | 8. Upper ventilator door motor | 9. Upper ventilator door rod |
| 10. Upper ventilator door lever | 11. Filter cover | 12. In-cabin microfilter/Air conditioner filter* |
| 13. Foot duct 1 (right) | 14. Foot duct 2 (right) | 15. Air mix door motor (passenger side) |
| 16. Heater & cooling unit case cover | 17. Evaporator pipe assembly | 18. O-ring |
| 19. Evaporator | 20. Expansion valve | 21. Case packing |
| 22. Grommet | 23. Cooler pipe grommet | 24. Drain hose |
| 25. Heater & cooling unit case (right) | 26. Air mix door (Slide door) | 27. Heater pipe support |
| 28. Heater pipe grommet | 29. Heater & cooling unit case (left) | 30. Heater core |
| 31. Heater pipe cover | 32. Foot duct 2 (left) | 33. Foot duct 1 (left) |
| 34. Heater duct | 35. Aspirator | 36. Aspirator hose |
| 37. Mode door motor | 38. Main link | 39. Rod link |
| 40. Max. cool door link | 41. Ventilator door link | 42. Foot door link |
| 43. Mode door lever | 44. Defroster door link | 45. Ventilator door lever |
| 46. Foot door lever | 47. Defroster door lever | 48. Max. cool door lever |
| 49. Air mix door motor (driver side) | 50. Distributor upper case | 51. Distributor lower case |
| 52. Ventilator door | 53. Foot door | 54. Max. cool door |
| 55. Defroster door | 56. Upper ventilator door | |

HEATER & COOLING UNIT ASSEMBLY

< REMOVAL AND INSTALLATION >

[WITH 7 INCH DISPLAY]

* : Models for Mexico.

Refer to [GI-4, "Components"](#) for symbols in the figure.

Removal and Installation

INFOID:000000006258647

REMOVAL

1. Collect the refrigerant with refrigerant collecting equipment (for HFC134a).
2. Drain engine coolant. Refer to [CO-11, "Draining"](#).
3. Remove the mounting bolt (A), and then disconnect the low-pressure pipe (1) and high-pressure pipe (2) from the expansion valve.

CAUTION:

Cap or wrap the joint of the A/C piping and expansion valve with suitable material such as vinyl tape to avoid the entry of air.

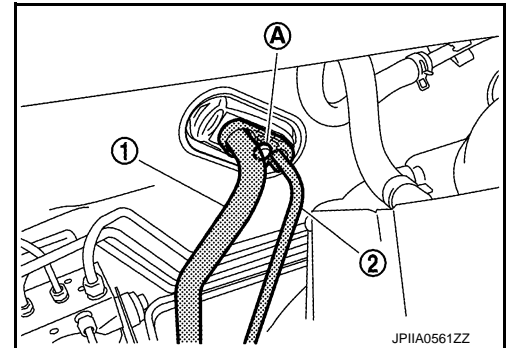

4. Remove the clamps (A), and then disconnect the heater hoses (1).

CAUTION:

- Some coolant may spill when heater hoses are disconnected. Wipe them off with wastes.
- Close the coolant inlet/outlet on the heater core and heater hoses with wastes.

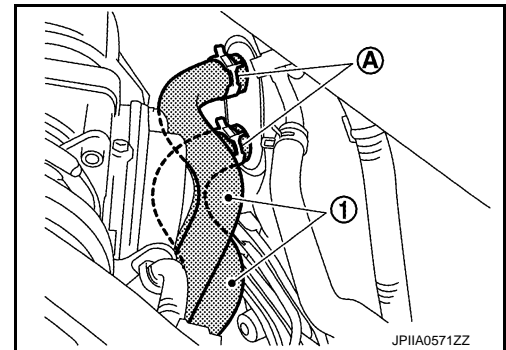

5. Remove the instrument panel assembly. Refer to [IP-12, "Exploded View"](#).
6. Remove the mounting nuts (A), and then remove the instrument stay (1).

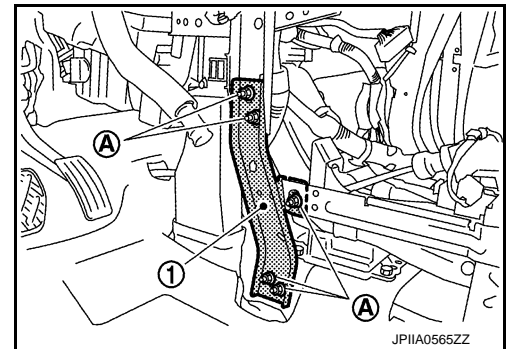

HEATER & COOLING UNIT ASSEMBLY

< REMOVAL AND INSTALLATION >

[WITH 7 INCH DISPLAY]

7. Remove the heater & cooling unit assembly and blower unit mounting bolts (A).

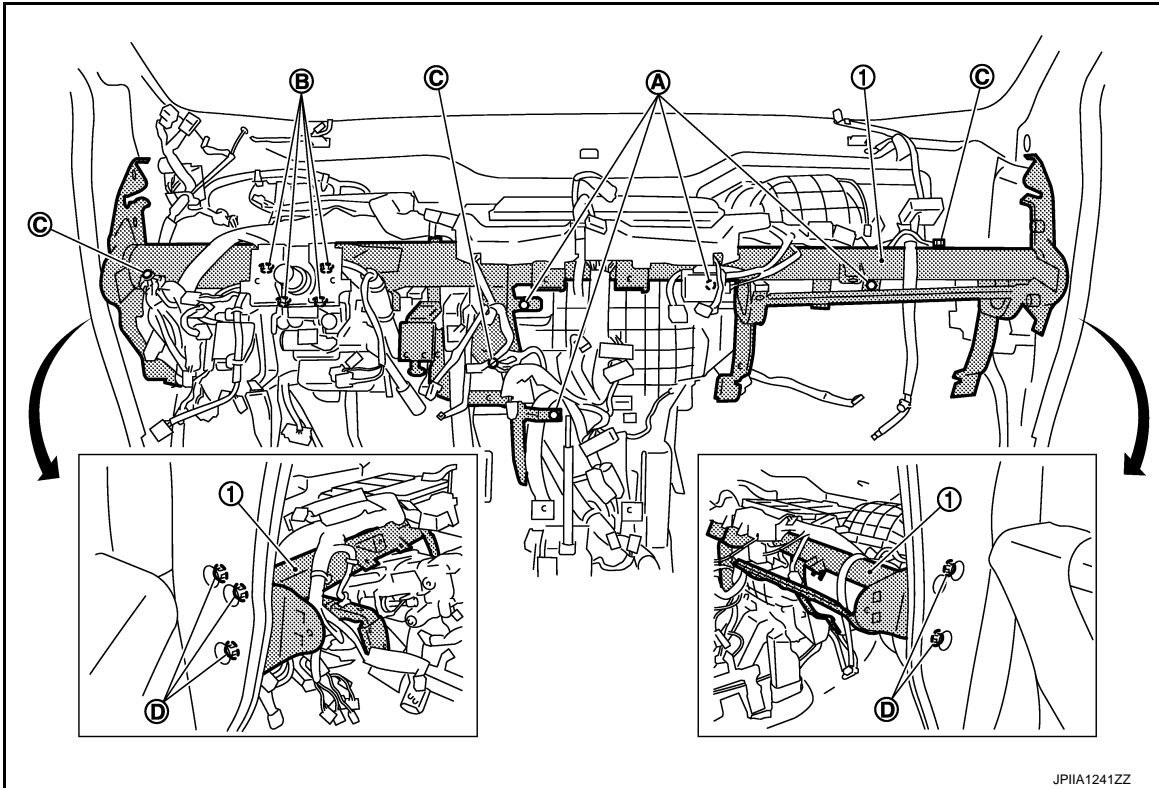

Refer to [GI-4, "Components"](#) for symbols shown in the figure.

8. Remove the steering column mounting nuts (B). Refer to [ST-35, "WITHOUT ELECTRIC MOTOR : Exploded View"](#) (without electric motor) or [ST-38, "WITH ELECTRIC MOTOR : Exploded View"](#) (with electric motor).
9. Remove the ground bolts (C) from the steering member (1).
10. Remove the harness clip from the steering member.
11. Disconnect the intake door motor and blower motor connectors.
12. Remove the steering member mounting bolts (D), and then remove the steering member.
13. Remove the mounting screw (A), and then remove the blower unit (1).

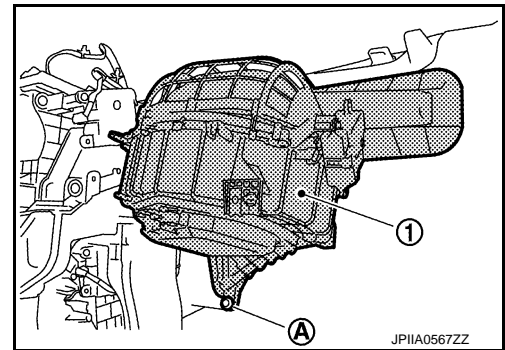

14. Disconnect the drain hose (1) from heater & cooling unit assembly.

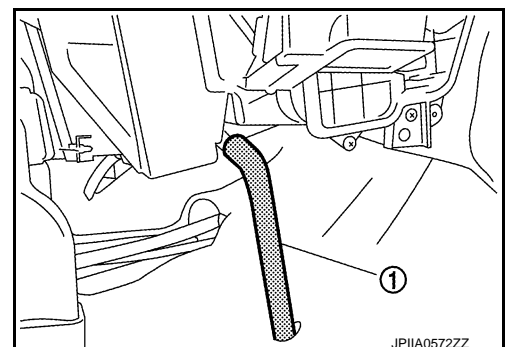

A
B
C
D
E
F
G
H

VTL

J
K
L
M
N
O
P

HEATER & COOLING UNIT ASSEMBLY

< REMOVAL AND INSTALLATION >

[WITH 7 INCH DISPLAY]

15. Remove the rear foot duct 1 (left/right) (A) and rear ventilator duct 1 (B), and then remove the heater & cooling unit assembly (1).

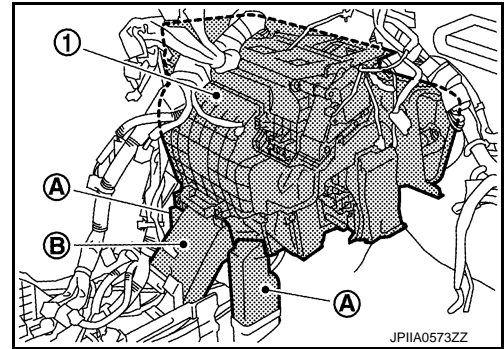

INSTALLATION

Install in the reverse order of removal.

CAUTION:

- Replace the O-ring with a new one. Apply a coat of compressor oil to the O-ring prior to installation.
- Check for refrigerant leakage when charging refrigerant.

NOTE:

- Refer to [CO-12, "Refilling"](#) when filling the radiator with engine coolant.
- Charge the refrigerant again.

UPPER VENTILATOR DOOR MOTOR

< REMOVAL AND INSTALLATION >

[WITH 7 INCH DISPLAY]

UPPER VENTILATOR DOOR MOTOR

Exploded View

INFOID:000000006258648

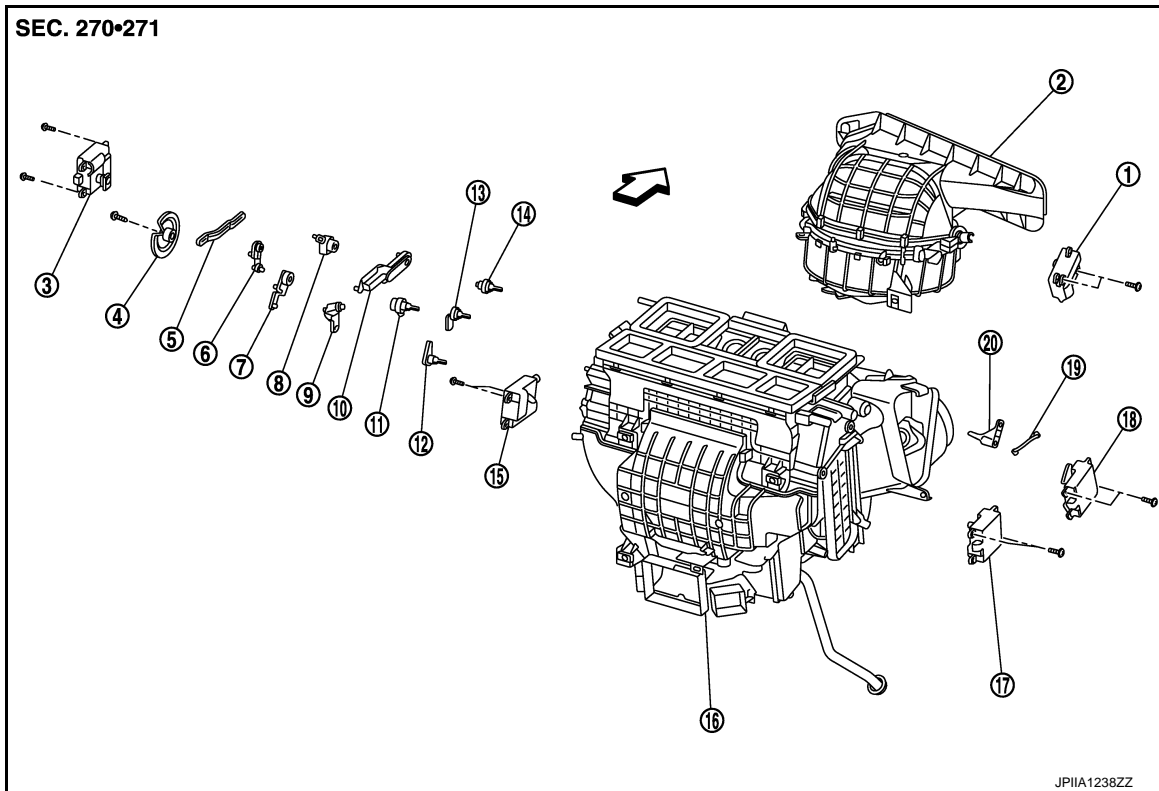

- | | | |
|------------------------------------|---|--------------------------------------|
| 1. Intake door motor | 2. Bower unit assembly | 3. Mode door motor |
| 4. Main link | 5. Rod link | 6. Max. cool door link |
| 7. Max. cool door link | 8. Mode door lever | 9. Ventilator door link |
| 10. Defroster door link | 11. Ventilator door lever | 12. Foot door lever |
| 13. Max. cool door lever | 14. Defroster door lever | 15. Air mix door motor (driver side) |
| 16. Heater & cooling unit assembly | 17. Air mix door motor (passenger side) | 18. Upper ventilator door motor |
| 19. Upper ventilator door rod | 20. Upper ventilator door lever | |

↔ : Vehicle front

Removal and Installation

INFOID:000000006258649

REMOVAL

1. Remove the blower unit. Refer to [VTL-92, "Exploded View"](#).
2. Remove the mounting screws (A), and then remove the upper ventilator door motor (1).
3. Disconnect the upper ventilator door motor connector.

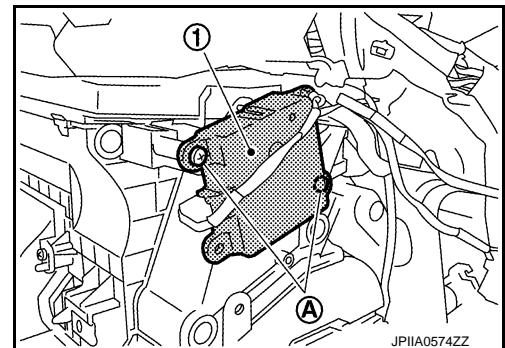

INSTALLATION

Install in the reverse order of removal.

MODE DOOR MOTOR

< REMOVAL AND INSTALLATION >

[WITH 7 INCH DISPLAY]

MODE DOOR MOTOR

Exploded View

INFOID:000000006258650

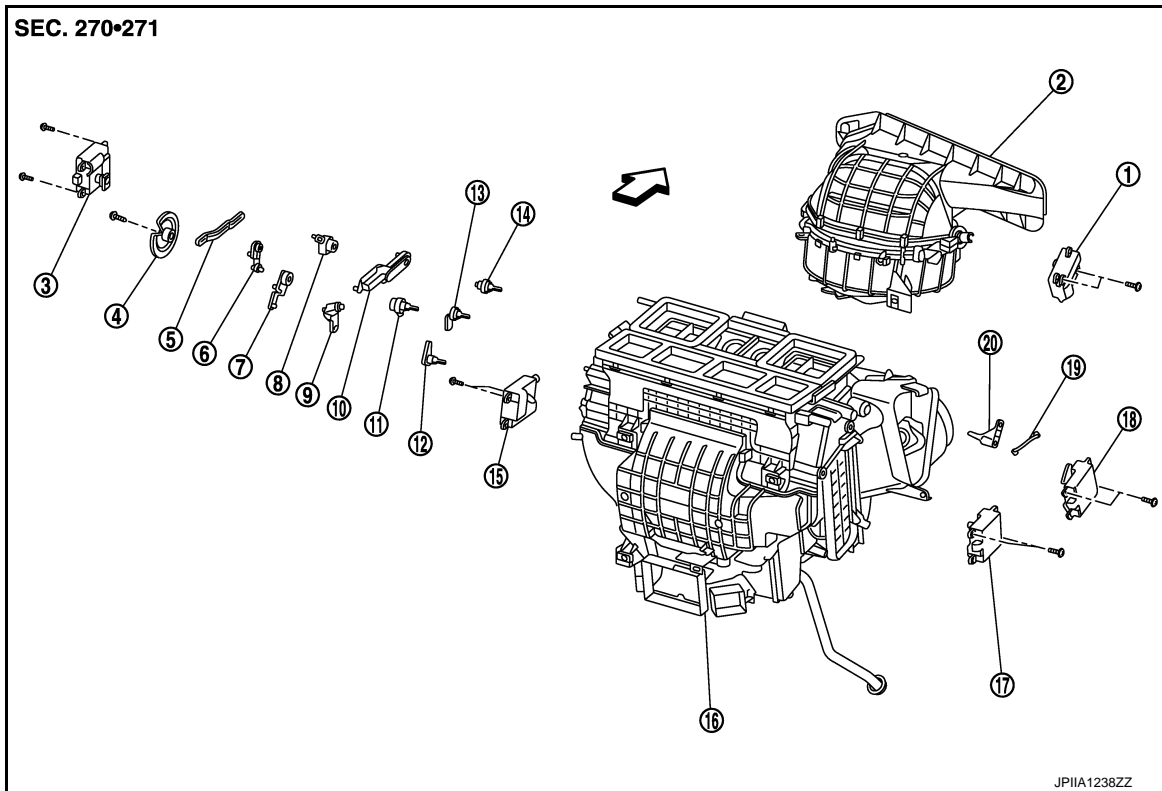

- | | | |
|------------------------------------|---|--------------------------------------|
| 1. Intake door motor | 2. Bower unit assembly | 3. Mode door motor |
| 4. Main link | 5. Rod link | 6. Max. cool door link |
| 7. Max. cool door link | 8. Mode door lever | 9. Ventilator door link |
| 10. Defroster door link | 11. Ventilator door lever | 12. Foot door lever |
| 13. Max. cool door lever | 14. Defroster door lever | 15. Air mix door motor (driver side) |
| 16. Heater & cooling unit assembly | 17. Air mix door motor (passenger side) | 18. Upper ventilator door motor |
| 19. Upper ventilator door rod | 20. Upper ventilator door lever | |

↙ : Vehicle front

Removal and Installation

INFOID:000000006258651

REMOVAL

1. Remove the instrument panel assembly. Refer to [IP-12, "Exploded View"](#).
2. Remove the mounting screws (A), and then remove the mode door motor (1).
3. Disconnect the mode door motor connector.

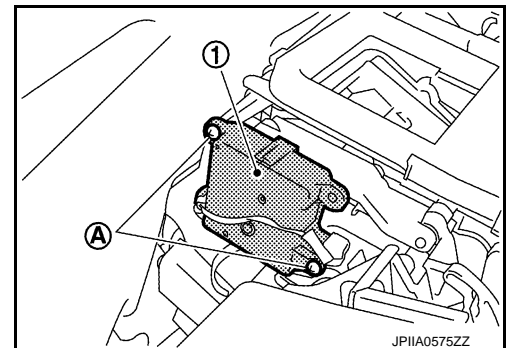

INSTALLATION

Install in the reverse order of removal.

AIR MIX DOOR MOTOR

< REMOVAL AND INSTALLATION >

[WITH 7 INCH DISPLAY]

AIR MIX DOOR MOTOR

Exploded View

INFOID:000000006258652

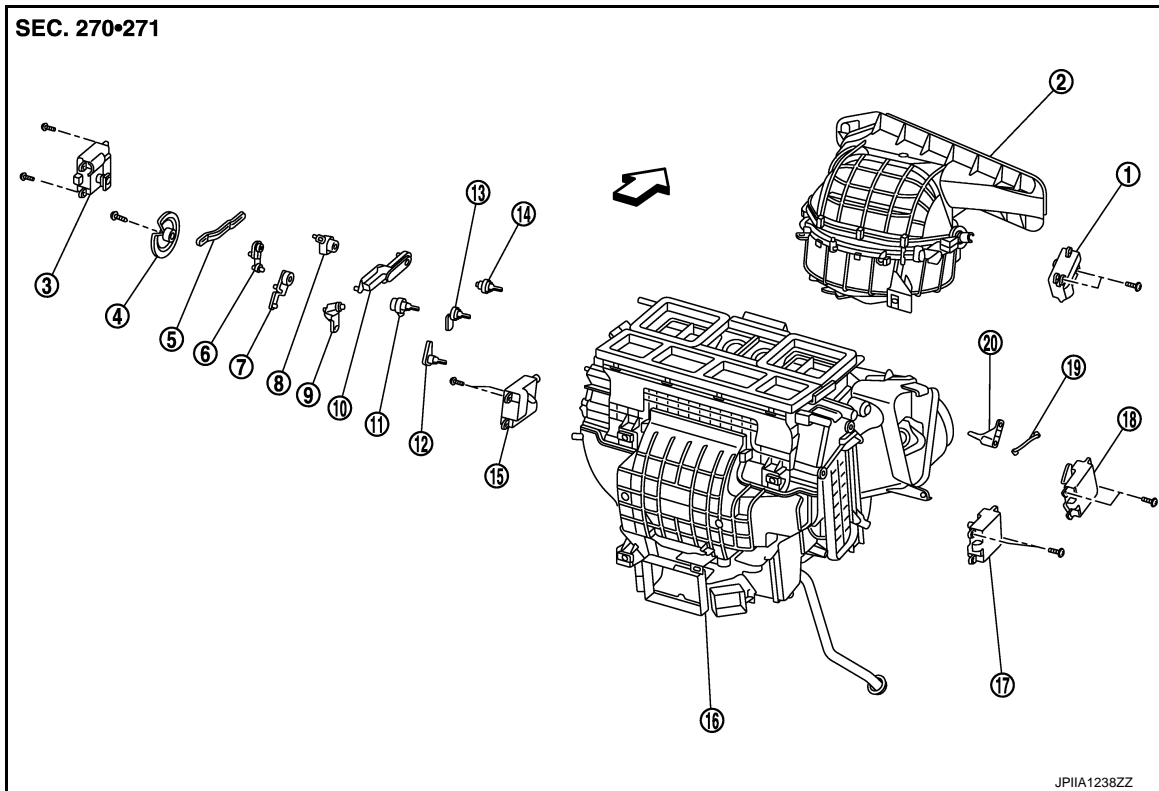

- | | | |
|------------------------------------|---|--------------------------------------|
| 1. Intake door motor | 2. Bower unit assembly | 3. Mode door motor |
| 4. Main link | 5. Rod link | 6. Max. cool door link |
| 7. Max. cool door link | 8. Mode door lever | 9. Ventilator door link |
| 10. Defroster door link | 11. Ventilator door lever | 12. Foot door lever |
| 13. Max. cool door lever | 14. Defroster door lever | 15. Air mix door motor (driver side) |
| 16. Heater & cooling unit assembly | 17. Air mix door motor (passenger side) | 18. Upper ventilator door motor |
| 19. Upper ventilator door rod | 20. Upper ventilator door lever | |

↔ : Vehicle front

Removal and Installation

INFOID:000000006258653

REMOVAL

Driver side

1. Set the temperature (driver side) at 18°C (60°F).

CAUTION:

The angle may be out, when installing the air mix door motor to the air mix door, unless the above procedure is performed.

2. Disconnect the battery cable from the negative terminal.
3. Remove the foot duct (left). Refer to [VTL-129. "FOOT DUCT : Exploded View"](#).

AIR MIX DOOR MOTOR

< REMOVAL AND INSTALLATION >

[WITH 7 INCH DISPLAY]

4. Remove the mounting screws (A), and then remove the air mix door motor (1).
5. Disconnect the air mix door motor connector.

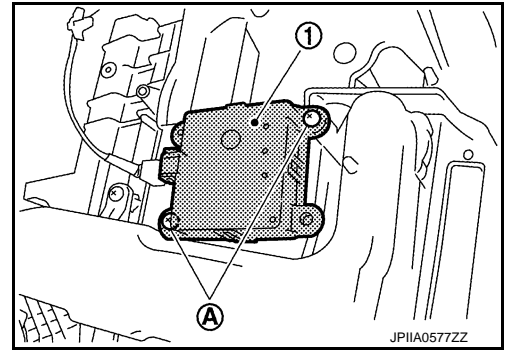

Passenger side

1. Set the temperature (passenger side) at 18°C (60°F).

CAUTION:

The angle may be out, when installing the air mix door motor to the air mix door, unless the above procedure is performed.

2. Disconnect the battery cable from the negative terminal.
3. Remove the foot duct (right). Refer to [VTL-129. "FOOT DUCT : Exploded View"](#).
4. Remove the mounting screws (A), and then remove the air mix door motor (1).
5. Disconnect the air mix door motor connector.

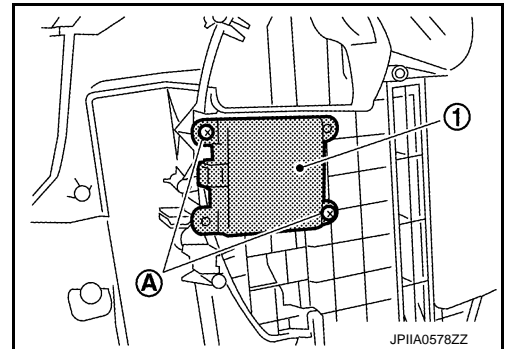

INSTALLATION

Install in the reverse order of removal.

HEATER CORE

< REMOVAL AND INSTALLATION >

[WITH 7 INCH DISPLAY]

HEATER CORE

Exploded View

INFOID:000000006258654

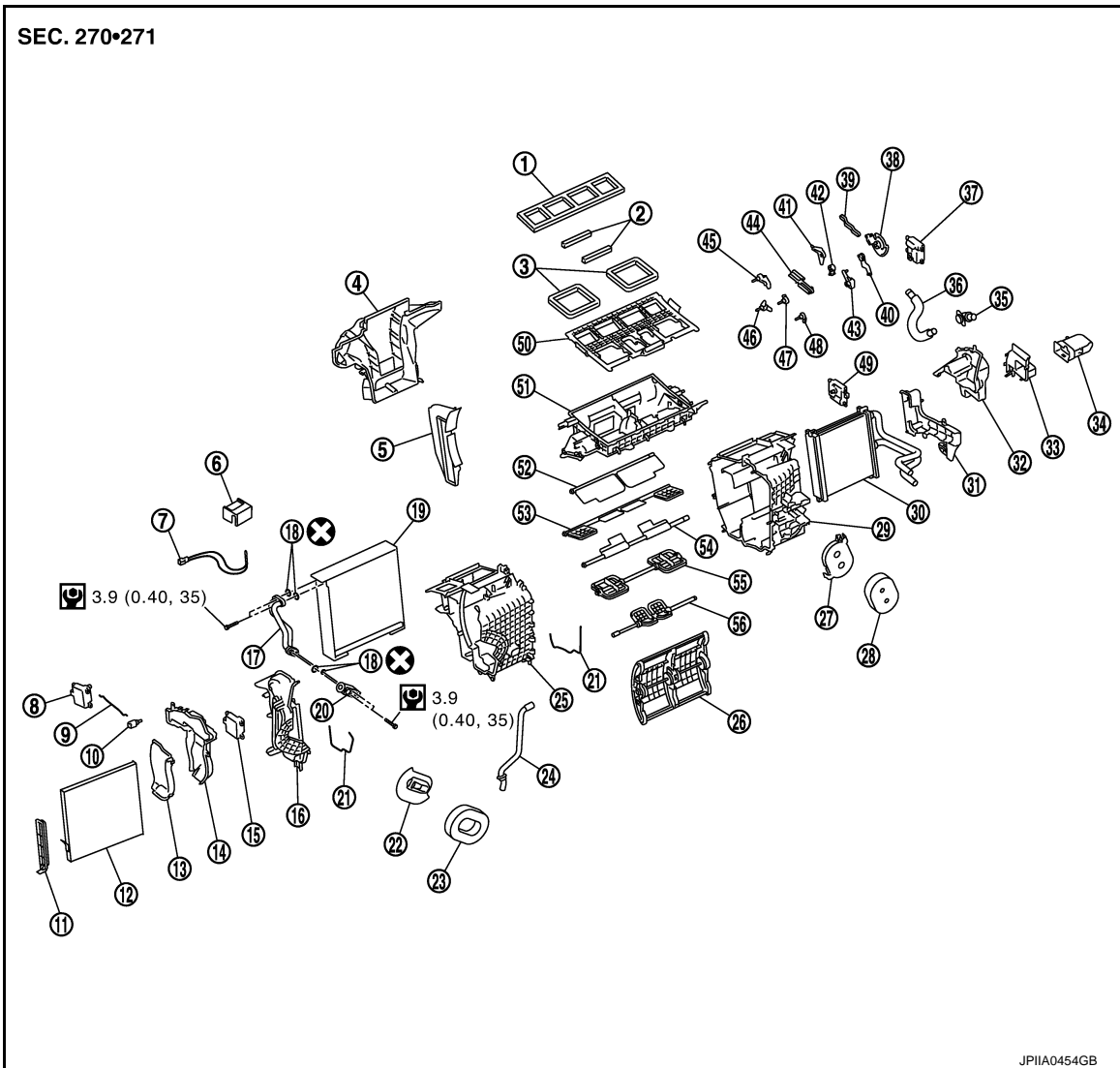

- | | | |
|--|---------------------------------------|--|
| 1. Ventilator seal | 2. Upper ventilator seal | 3. Defroster seal |
| 4. Adapter case | 5. Center case | 6. Intake sensor bracket |
| 7. Intake sensor | 8. Upper ventilator door motor | 9. Upper ventilator door rod |
| 10. Upper ventilator door lever | 11. Filter cover | 12. In-cabin microfilter/Air conditioner filter* |
| 13. Foot duct 1 (right) | 14. Foot duct 2 (right) | 15. Air mix door motor (passenger side) |
| 16. Heater & cooling unit case cover | 17. Evaporator pipe assembly | 18. O-ring |
| 19. Evaporator | 20. Expansion valve | 21. Case packing |
| 22. Grommet | 23. Cooler pipe grommet | 24. Drain hose |
| 25. Heater & cooling unit case (right) | 26. Air mix door (Slide door) | 27. Heater pipe support |
| 28. Heater pipe grommet | 29. Heater & cooling unit case (left) | 30. Heater core |
| 31. Heater pipe cover | 32. Foot duct 2 (left) | 33. Foot duct 1 (left) |
| 34. Heater duct | 35. Aspirator | 36. Aspirator hose |
| 37. Mode door motor | 38. Main link | 39. Rod link |
| 40. Max. cool door link | 41. Ventilator door link | 42. Foot door link |
| 43. Mode door lever | 44. Defroster door link | 45. Ventilator door lever |

HEATER CORE

< REMOVAL AND INSTALLATION >

[WITH 7 INCH DISPLAY]

- | | | |
|--------------------------------------|----------------------------|----------------------------|
| 46. Foot door lever | 47. Defroster door lever | 48. Max. cool door lever |
| 49. Air mix door motor (driver side) | 50. Distributor upper case | 51. Distributor lower case |
| 52. Ventilator door | 53. Foot door | 54. Max. cool door |
| 55. Defroster door | 56. Upper ventilator door | |
- * : Models for Mexico.

Refer to [GI-4. "Components"](#) for symbols in the figure.

Removal and Installation

INFOID:000000006258655

REMOVAL

1. Remove the heater & cooling unit assembly. Refer to [VTL-98. "Exploded View"](#).
2. Remove the mounting screws (A), and then remove the foot duct (left) (1).

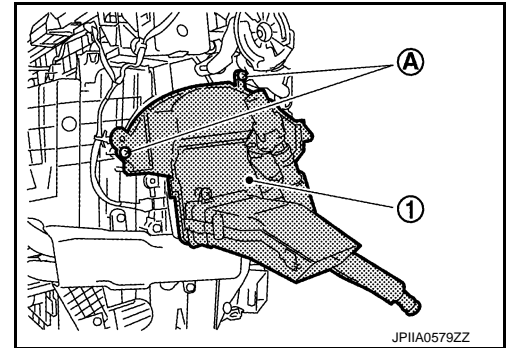

3. Remove the heater pipe grommet (1).
4. Remove the mounting screw (A), and then remove the heater pipe support (2).
5. Remove the mounting screws (B), and then remove the heater pipe cover (3).

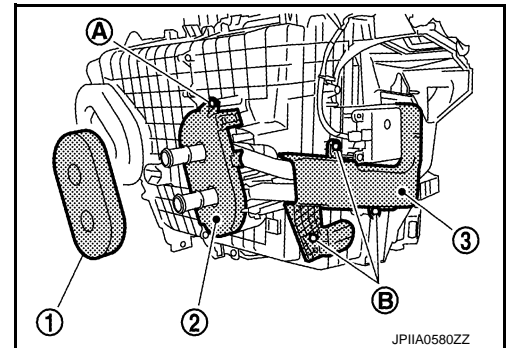

6. Slide the heater core (1) in the direction shown by the arrow, and then remove it.

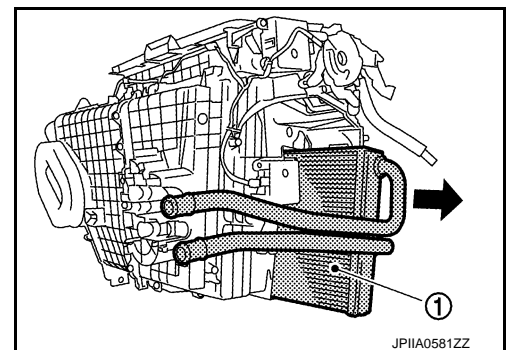

INSTALLATION

Install in the reverse order of removal.

CAUTION:

- Replace the O-ring with a new one. Apply a coat of compressor oil to the O-ring prior to installation.
- Check for refrigerant leakage when charging refrigerant.

NOTE:

- Refer to [CO-12. "Refilling"](#) when filling the radiator with engine coolant.
- Charge the refrigerant again.

DUCT AND GRILLE

< REMOVAL AND INSTALLATION >

[WITH 7 INCH DISPLAY]

DUCT AND GRILLE CENTER VENTILATOR GRILLE

CENTER VENTILATOR GRILLE : Exploded View

INFOID:000000006258656

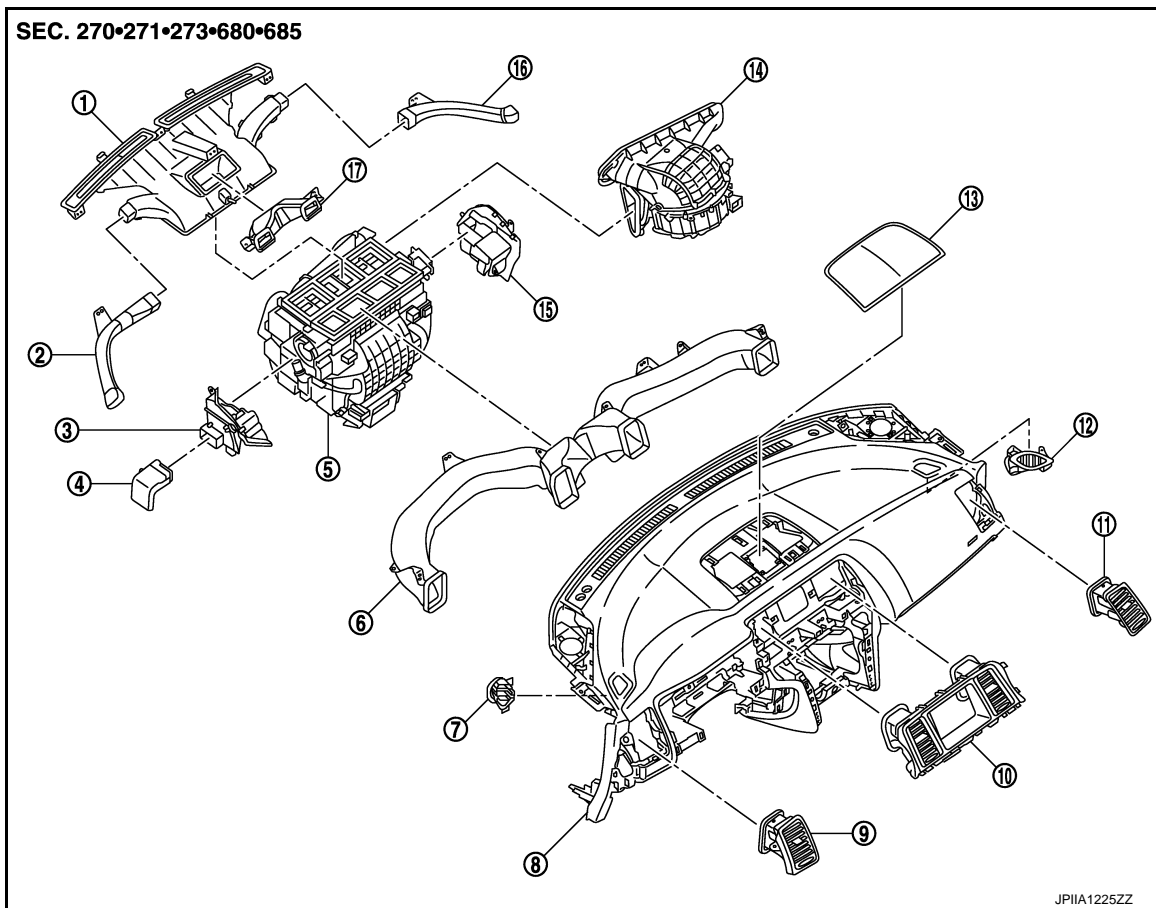

- | | | |
|---------------------------------------|------------------------------------|-----------------------------------|
| 1. Defroster nozzle | 2. Side defroster nozzle (left) | 3. Foot duct (left) |
| 4. Heater duct | 5. Heater & cooling unit assembly | 6. Ventilator duct |
| 7. Side defroster grille (left) | 8. Instrument panel assembly | 9. Side ventilator grille (left) |
| 10. Center ventilator grille assembly | 11. Side ventilator grille (right) | 12. Side defroster grille (right) |
| 13. Center speaker grille | 14. Blower unit assembly | 15. Foot duct (right) |
| 16. Side defroster nozzle (right) | 17. Upper ventilator duct | |

CENTER VENTILATOR GRILLE : Removal and Installation

INFOID:000000006258657

REMOVAL

1. Remove the cluster lid A. Refer to [IP-12, "Exploded View"](#).
2. Remove the cluster lid D. Refer to [IP-12, "Exploded View"](#).

DUCT AND GRILLE

< REMOVAL AND INSTALLATION >

[WITH 7 INCH DISPLAY]

3. Remove the mounting screws (A), and then remove the center ventilator grille assembly (1).

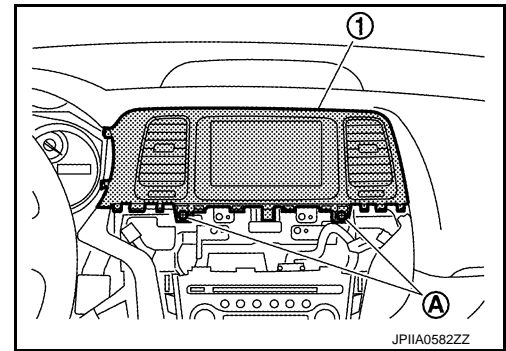

INSTALLATION

Install in the reverse order of removal.

SIDE VENTILATOR GRILLE

SIDE VENTILATOR GRILLE : Exploded View

INFOID:000000006258658

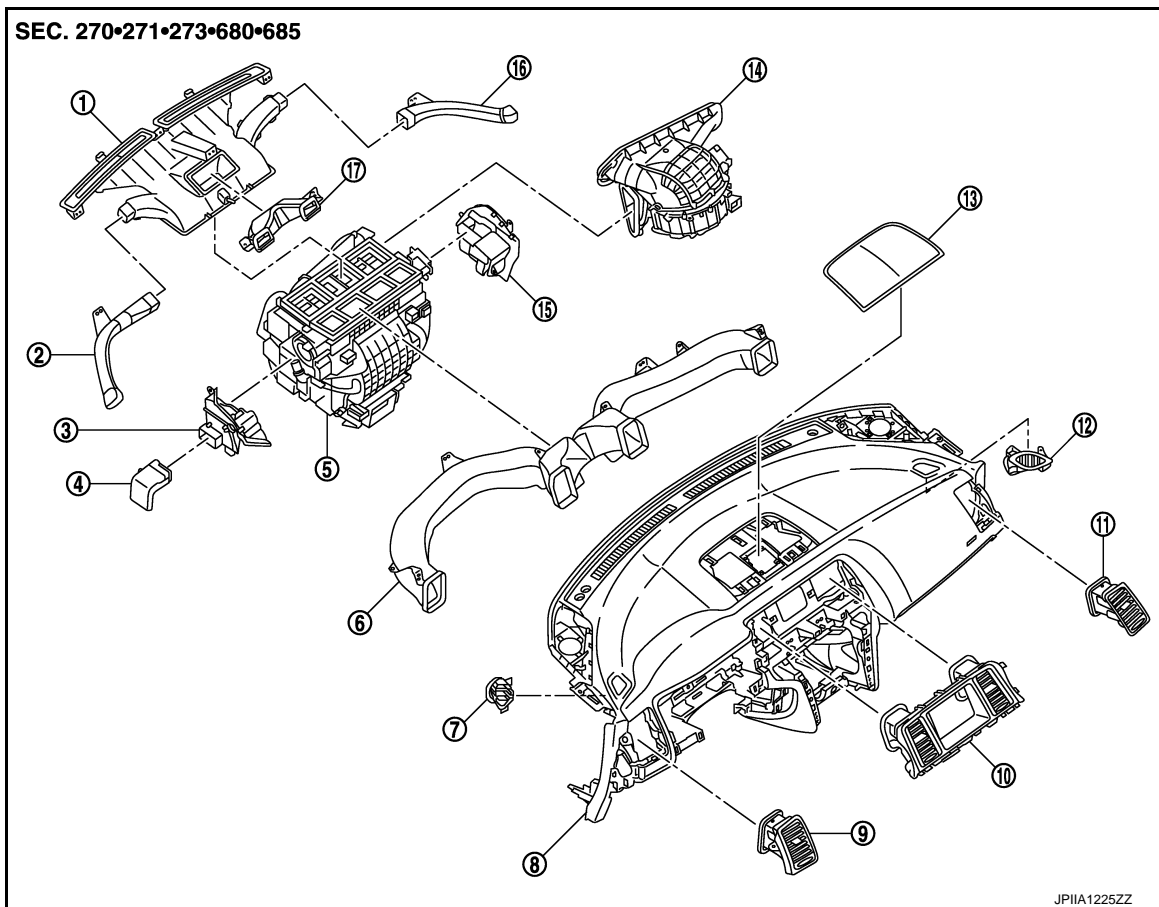

- | | | |
|---------------------------------------|------------------------------------|-----------------------------------|
| 1. Defroster nozzle | 2. Side defroster nozzle (left) | 3. Foot duct (left) |
| 4. Heater duct | 5. Heater & cooling unit assembly | 6. Ventilator duct |
| 7. Side defroster grille (left) | 8. Instrument panel assembly | 9. Side ventilator grille (left) |
| 10. Center ventilator grille assembly | 11. Side ventilator grille (right) | 12. Side defroster grille (right) |
| 13. Center speaker grille | 14. Blower unit assembly | 15. Foot duct (right) |
| 16. Side defroster nozzle (right) | 17. Upper ventilator duct | |

SIDE VENTILATOR GRILLE : Removal and Installation

INFOID:000000006258659

REMOVAL

DUCT AND GRILLE

< REMOVAL AND INSTALLATION >

[WITH 7 INCH DISPLAY]

1. Remove the instrument side finisher (LH/RH). Refer to [JP-12, "Exploded View"](#).
2. Remove the mounting screw (A).
3. Remove side ventilator grille metal clip using remover tool (B), and then remove side ventilator grille (1).

 : Metal clip

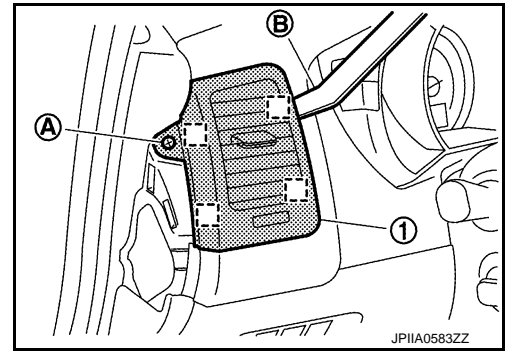

INSTALLATION

Install in the reverse order of removal.

SIDE DEFROSTER GRILLE

SIDE DEFROSTER GRILLE : Exploded View

INFOID:000000006258660

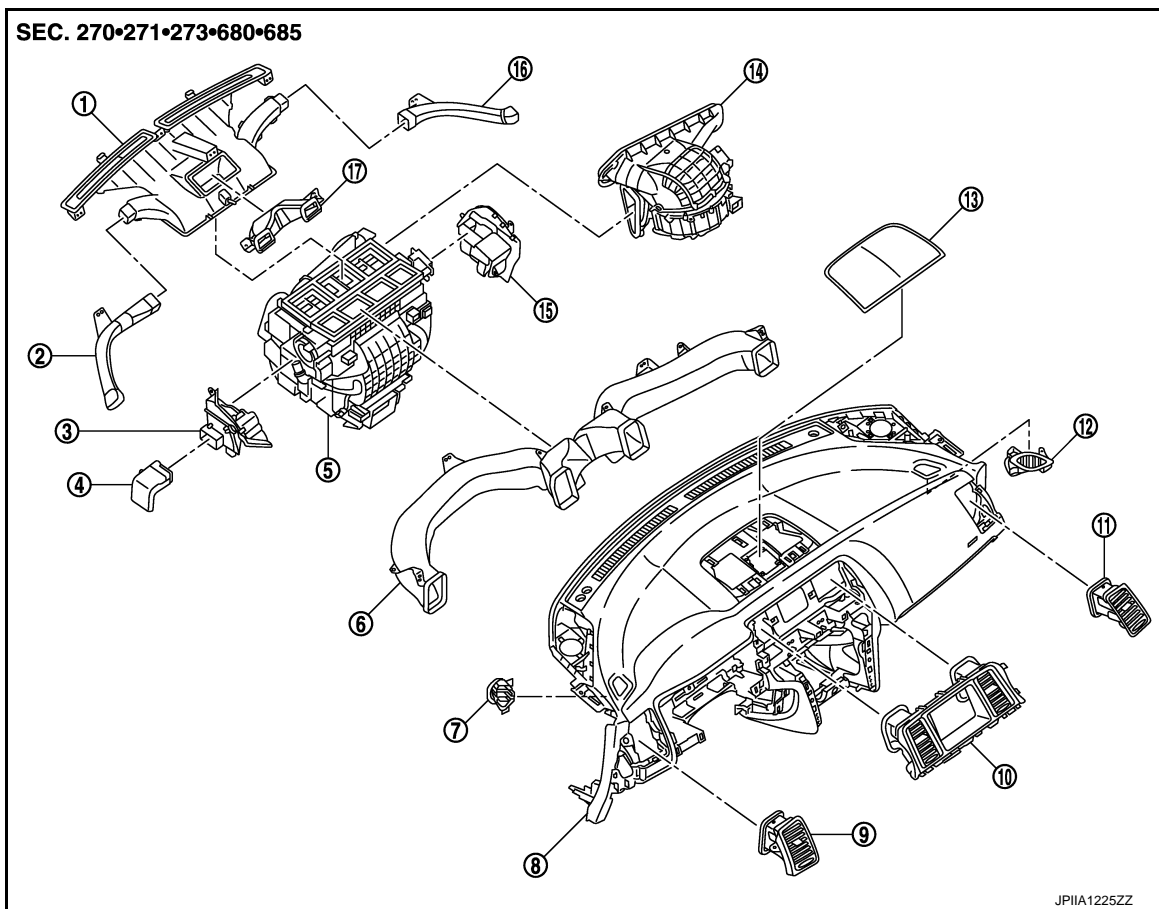

- | | | |
|---------------------------------------|------------------------------------|-----------------------------------|
| 1. Defroster nozzle | 2. Side defroster nozzle (left) | 3. Foot duct (left) |
| 4. Heater duct | 5. Heater & cooling unit assembly | 6. Ventilator duct |
| 7. Side defroster grille (left) | 8. Instrument panel assembly | 9. Side ventilator grille (left) |
| 10. Center ventilator grille assembly | 11. Side ventilator grille (right) | 12. Side defroster grille (right) |
| 13. Center speaker grille | 14. Blower unit assembly | 15. Foot duct (right) |
| 16. Side defroster nozzle (right) | 17. Upper ventilator duct | |

DUCT AND GRILLE

< REMOVAL AND INSTALLATION >

[WITH 7 INCH DISPLAY]

SIDE DEFROSTER GRILLE : Removal and Installation

INFOID:000000006258661

REMOVAL

1. Remove the defroster nozzle and side defroster nozzle. Refer to [VTL-115. "DEFROSTER NOZZLE AND SIDE DEFROSTER NOZZLE : Exploded View"](#).
2. Remove the mounting screws (A), and then remove the side defroster grilles (left/right) (1).

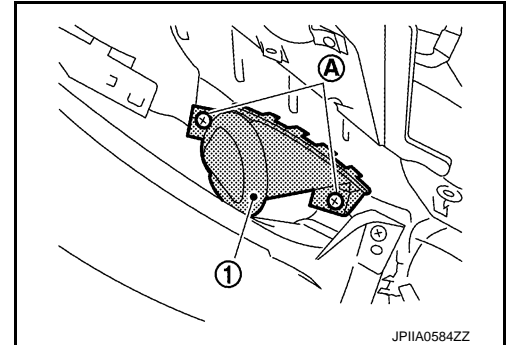

INSTALLATION

Install in the reverse order of removal.

VENTILATOR DUCT

VENTILATOR DUCT : Exploded View

INFOID:000000006258662

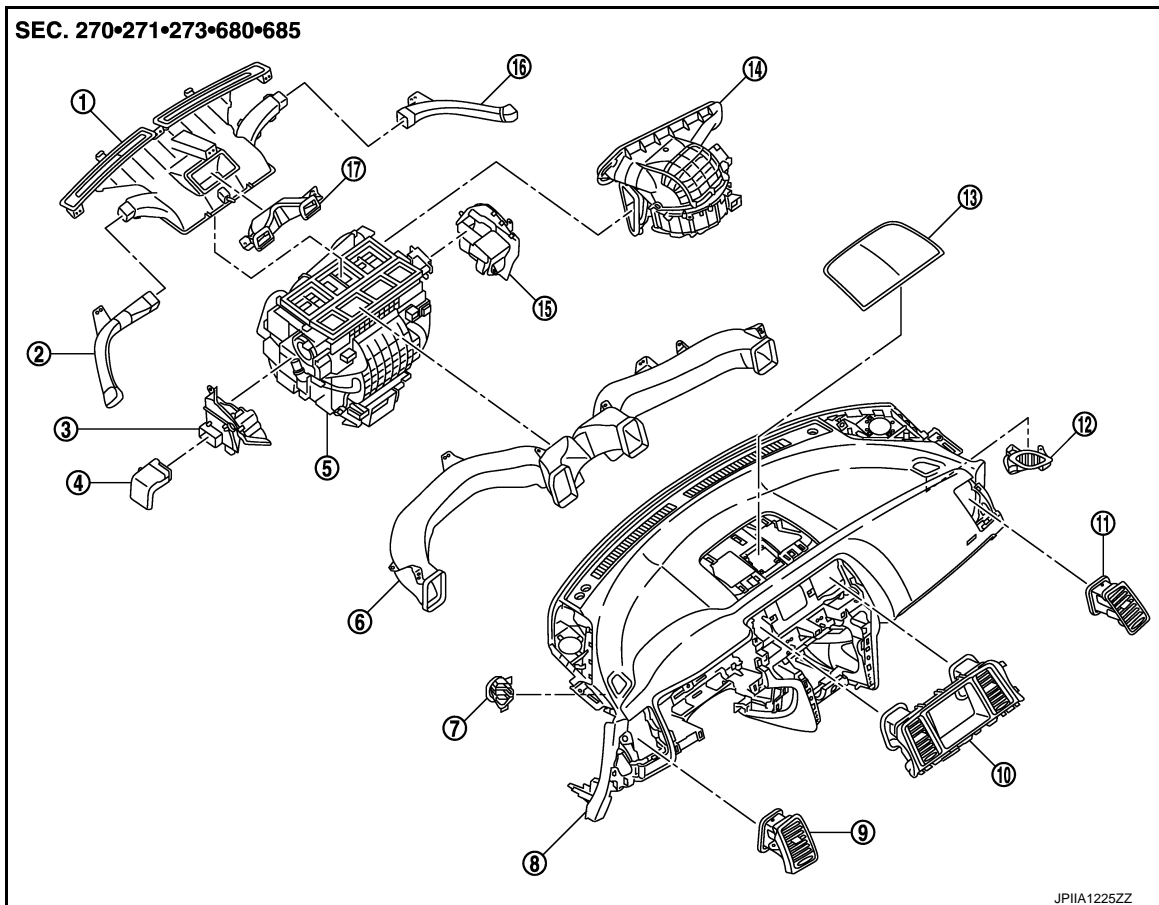

- | | | |
|---------------------------------------|------------------------------------|-----------------------------------|
| 1. Defroster nozzle | 2. Side defroster nozzle (left) | 3. Foot duct (left) |
| 4. Heater duct | 5. Heater & cooling unit assembly | 6. Ventilator duct |
| 7. Side defroster grille (left) | 8. Instrument panel assembly | 9. Side ventilator grille (left) |
| 10. Center ventilator grille assembly | 11. Side ventilator grille (right) | 12. Side defroster grille (right) |

DUCT AND GRILLE

< REMOVAL AND INSTALLATION >

[WITH 7 INCH DISPLAY]

- | | | |
|-----------------------------------|---------------------------|-----------------------|
| 13. Center speaker grille | 14. Blower unit assembly | 15. Foot duct (right) |
| 16. Side defroster nozzle (right) | 17. Upper ventilator duct | |

VENTILATOR DUCT : Removal and Installation

INFOID:000000006258663

REMOVAL

1. Remove the defroster nozzle and side defroster nozzle. Refer to [VTL-115, "DEFROSTER NOZZLE AND SIDE DEFROSTER NOZZLE : Exploded View"](#).
2. Remove the mounting screws (A), and then remove the ventilator duct (1).

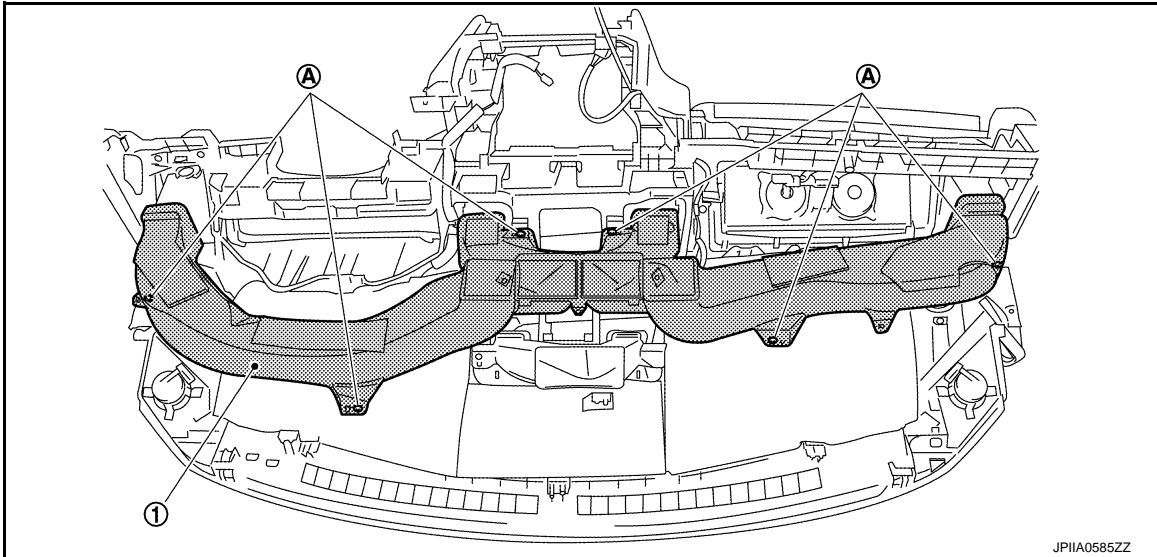

INSTALLATION

Install in the reverse order of removal.

UPPER VENTILATOR DUCT

A
B
C
D
E
F
G
H
VTL
J
K
L
M
N
O
P

DUCT AND GRILLE

< REMOVAL AND INSTALLATION >

[WITH 7 INCH DISPLAY]

UPPER VENTILATOR DUCT : Exploded View

INFOID:000000006258664

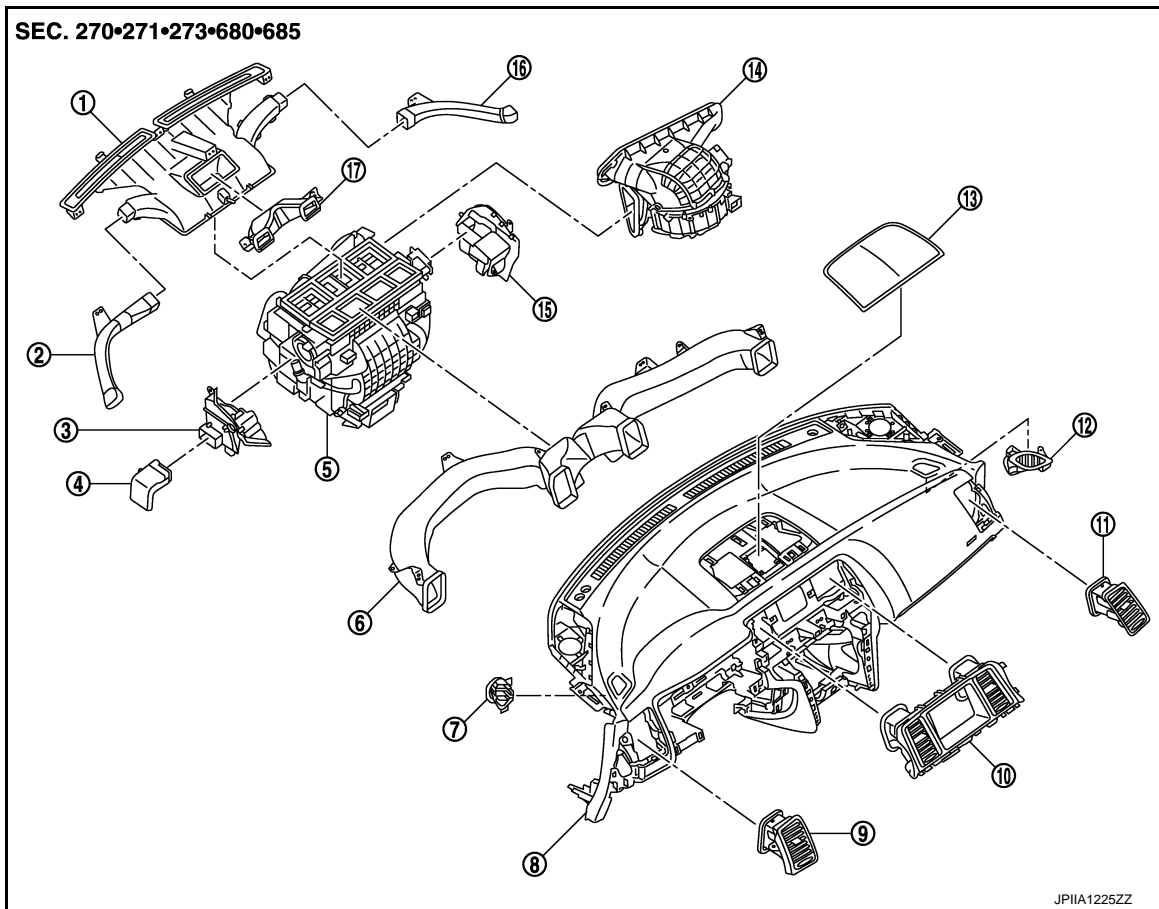

- | | | |
|---------------------------------------|------------------------------------|-----------------------------------|
| 1. Defroster nozzle | 2. Side defroster nozzle (left) | 3. Foot duct (left) |
| 4. Heater duct | 5. Heater & cooling unit assembly | 6. Ventilator duct |
| 7. Side defroster grille (left) | 8. Instrument panel assembly | 9. Side ventilator grille (left) |
| 10. Center ventilator grille assembly | 11. Side ventilator grille (right) | 12. Side defroster grille (right) |
| 13. Center speaker grille | 14. Blower unit assembly | 15. Foot duct (right) |
| 16. Side defroster nozzle (right) | 17. Upper ventilator duct | |

UPPER VENTILATOR DUCT : Removal and Installation

INFOID:000000006258665

REMOVAL

1. Remove the defroster nozzle and side defroster nozzle. Refer to [VTL-115, "DEFROSTER NOZZLE AND SIDE DEFROSTER NOZZLE : Exploded View"](#).
2. Remove the mounting screws (A), and then remove the upper ventilator duct (1).

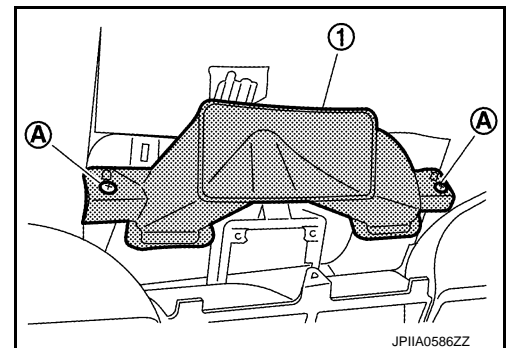

INSTALLATION

Install in the reverse order of removal.

DUCT AND GRILLE

< REMOVAL AND INSTALLATION >

[WITH 7 INCH DISPLAY]

DEFROSTER NOZZLE AND SIDE DEFROSTER NOZZLE

DEFROSTER NOZZLE AND SIDE DEFROSTER NOZZLE : Exploded View

INFOID:000000006258666

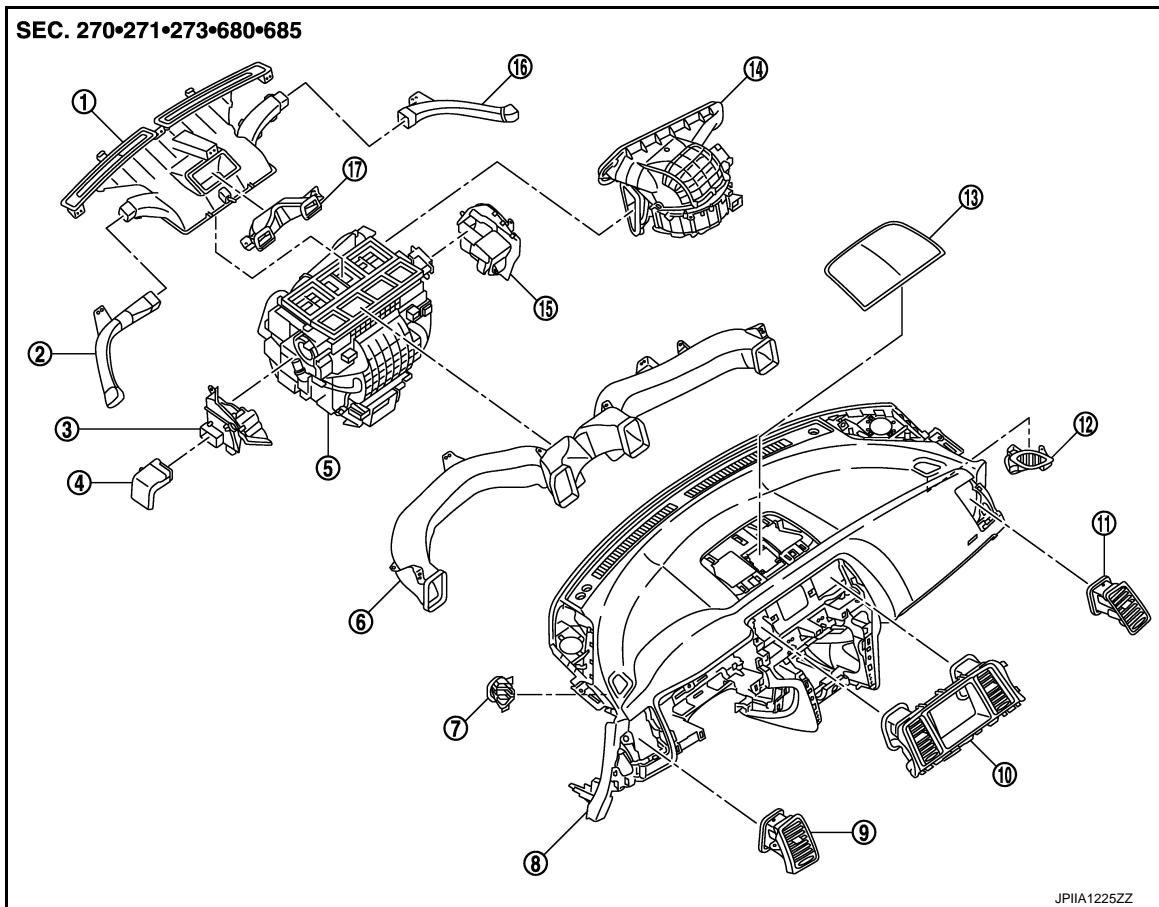

- | | | |
|---------------------------------------|------------------------------------|-----------------------------------|
| 1. Defroster nozzle | 2. Side defroster nozzle (left) | 3. Foot duct (left) |
| 4. Heater duct | 5. Heater & cooling unit assembly | 6. Ventilator duct |
| 7. Side defroster grille (left) | 8. Instrument panel assembly | 9. Side ventilator grille (left) |
| 10. Center ventilator grille assembly | 11. Side ventilator grille (right) | 12. Side defroster grille (right) |
| 13. Center speaker grille | 14. Blower unit assembly | 15. Foot duct (right) |
| 16. Side defroster nozzle (right) | 17. Upper ventilator duct | |

DEFROSTER NOZZLE AND SIDE DEFROSTER NOZZLE : Removal and Installation

INFOID:000000006258667

REMOVAL

1. Remove the instrument panel assembly. Refer to [IP-12, "Exploded View"](#).

DUCT AND GRILLE

< REMOVAL AND INSTALLATION >

[WITH 7 INCH DISPLAY]

2. Remove the mounting screws (A), and then remove the defroster nozzle (1) together with the side defroster nozzle (right) (2) and side defroster nozzle (left) (3).

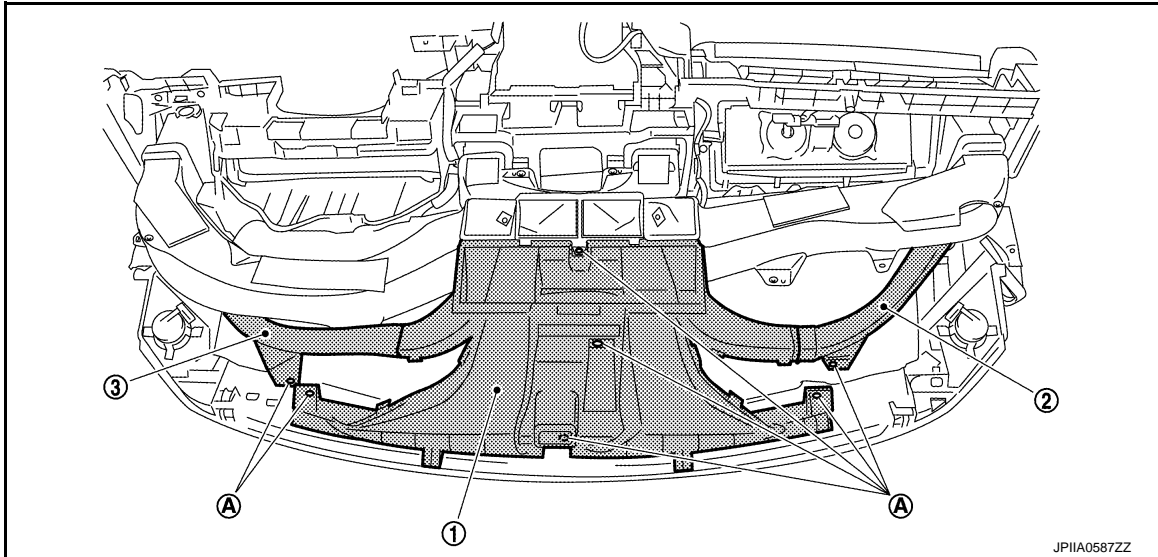

3. Remove the side defroster nozzle (right) and side defroster nozzle (left) from the defroster nozzle.

INSTALLATION

Install in the reverse order of removal.

REAR VENTILATOR GRILLE

REAR VENTILATOR GRILLE : Exploded View

INFOID:000000006258668

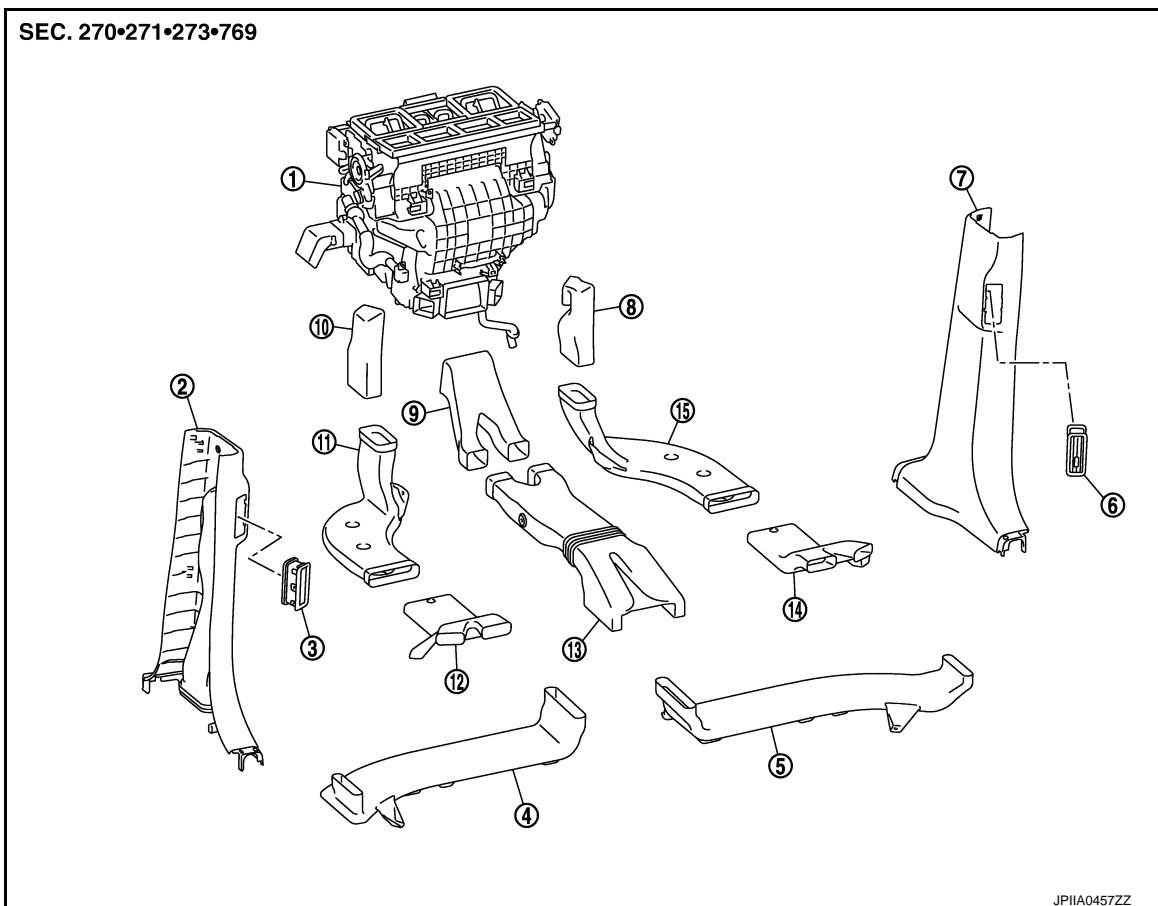

DUCT AND GRILLE

< REMOVAL AND INSTALLATION >

[WITH 7 INCH DISPLAY]

- | | | |
|---|--|-----------------------------------|
| 1. Heater & cooling unit assembly | 2. Rear ventilator duct 4 (center pillar lower garnish left) | 3. Rear ventilator grille (left) |
| 4. Rear ventilator duct 3 (left) | 5. Rear ventilator duct 3 (right) | 6. Rear ventilator grille (right) |
| 7. Rear ventilator duct 4 (center pillar lower garnish right) | 8. Rear foot duct 1 (right) | 9. Rear ventilator duct 1 |
| 10. Rear foot duct 1 (left) | 11. Rear foot duct 2 (left) | 12. Rear foot duct 3 (left) |
| 13. Rear ventilator duct 2 | 14. Rear foot duct 3 (right) | 15. Rear foot duct 2 (right) |

A
B
C

REAR VENTILATOR GRILLE : Removal and Installation

INFOID:000000006258669

REMOVAL

1. Remove the center pillar lower garnish (left/right). Refer to [INT-20, "Exploded View"](#).
2. Disengage the joints of the tabs, and then remove the rear ventilator grilles (left/right) (1).

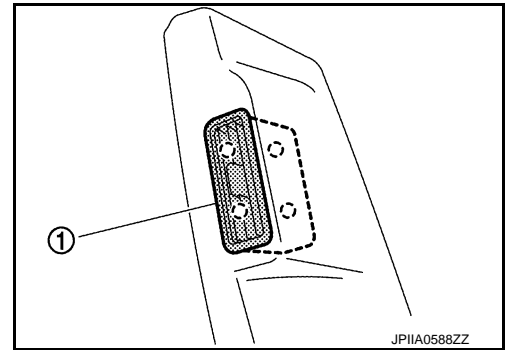

D
E
F
G
H

INSTALLATION

Install in the reverse order of removal.

REAR VENTILATOR DUCT 1

VTL

J
K
L
M
N
O
P

DUCT AND GRILLE

< REMOVAL AND INSTALLATION >

[WITH 7 INCH DISPLAY]

REAR VENTILATOR DUCT 1 : Exploded View

INFOID:000000006258670

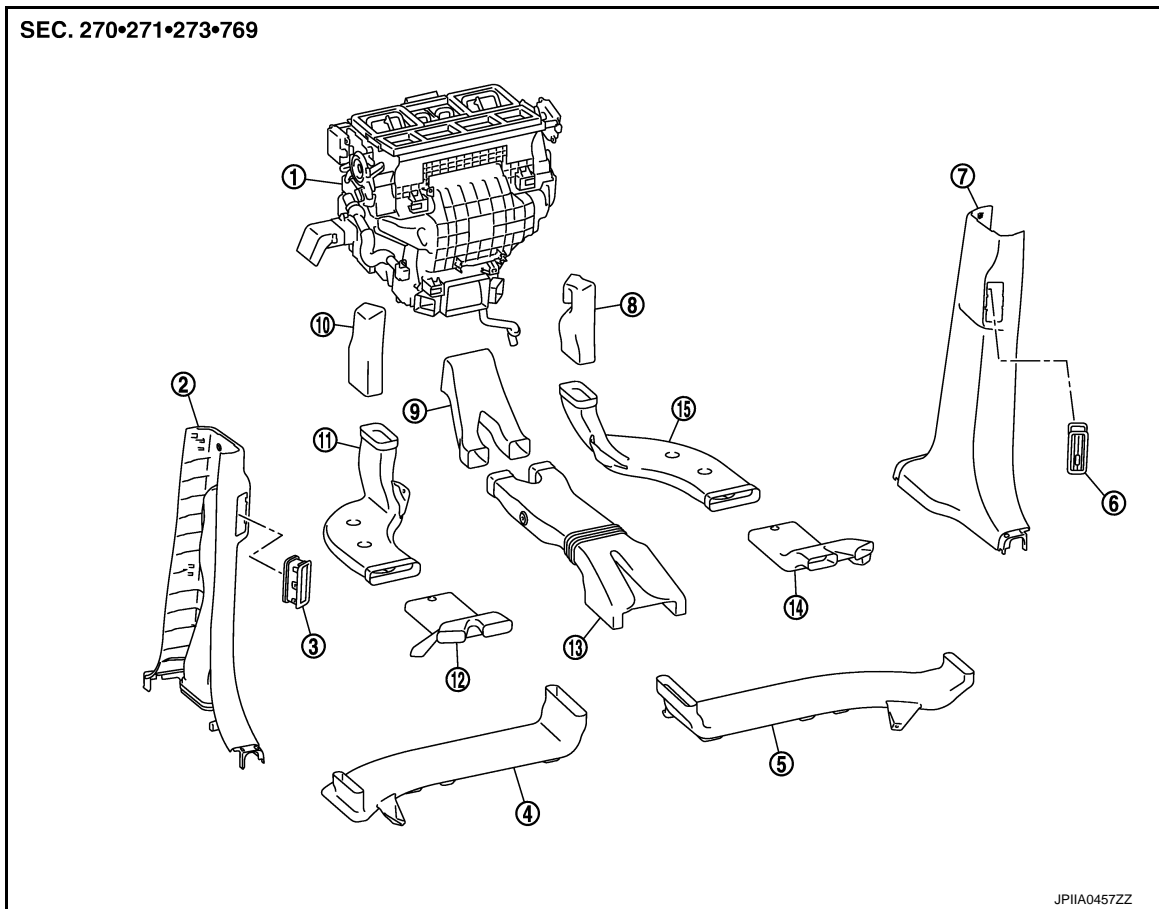

- | | | |
|---|--|-----------------------------------|
| 1. Heater & cooling unit assembly | 2. Rear ventilator duct 4 (center pillar lower garnish left) | 3. Rear ventilator grille (left) |
| 4. Rear ventilator duct 3 (left) | 5. Rear ventilator duct 3 (right) | 6. Rear ventilator grille (right) |
| 7. Rear ventilator duct 4 (center pillar lower garnish right) | 8. Rear foot duct 1 (right) | 9. Rear ventilator duct 1 |
| 10. Rear foot duct 1 (left) | 11. Rear foot duct 2 (left) | 12. Rear foot duct 3 (left) |
| 13. Rear ventilator duct 2 | 14. Rear foot duct 3 (right) | 15. Rear foot duct 2 (right) |

REAR VENTILATOR DUCT 1 : Removal and Installation

INFOID:000000006258671

REMOVAL

1. Remove the rear ventilator duct 2. Refer to [VTL-119, "REAR VENTILATOR DUCT 2 : Exploded View"](#).
2. Remove the rear ventilator duct 1 (1).

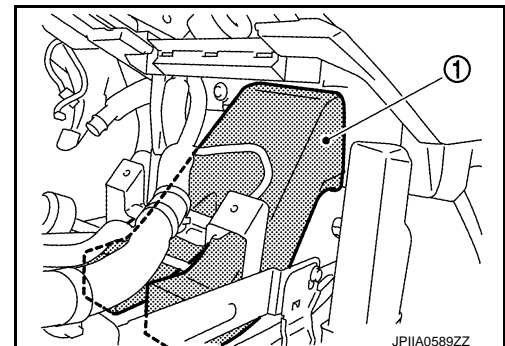

INSTALLATION

Install in the reverse order of removal.

DUCT AND GRILLE

< REMOVAL AND INSTALLATION >

[WITH 7 INCH DISPLAY]

REAR VENTILATOR DUCT 2

REAR VENTILATOR DUCT 2 : Exploded View

INFOID:000000006258672

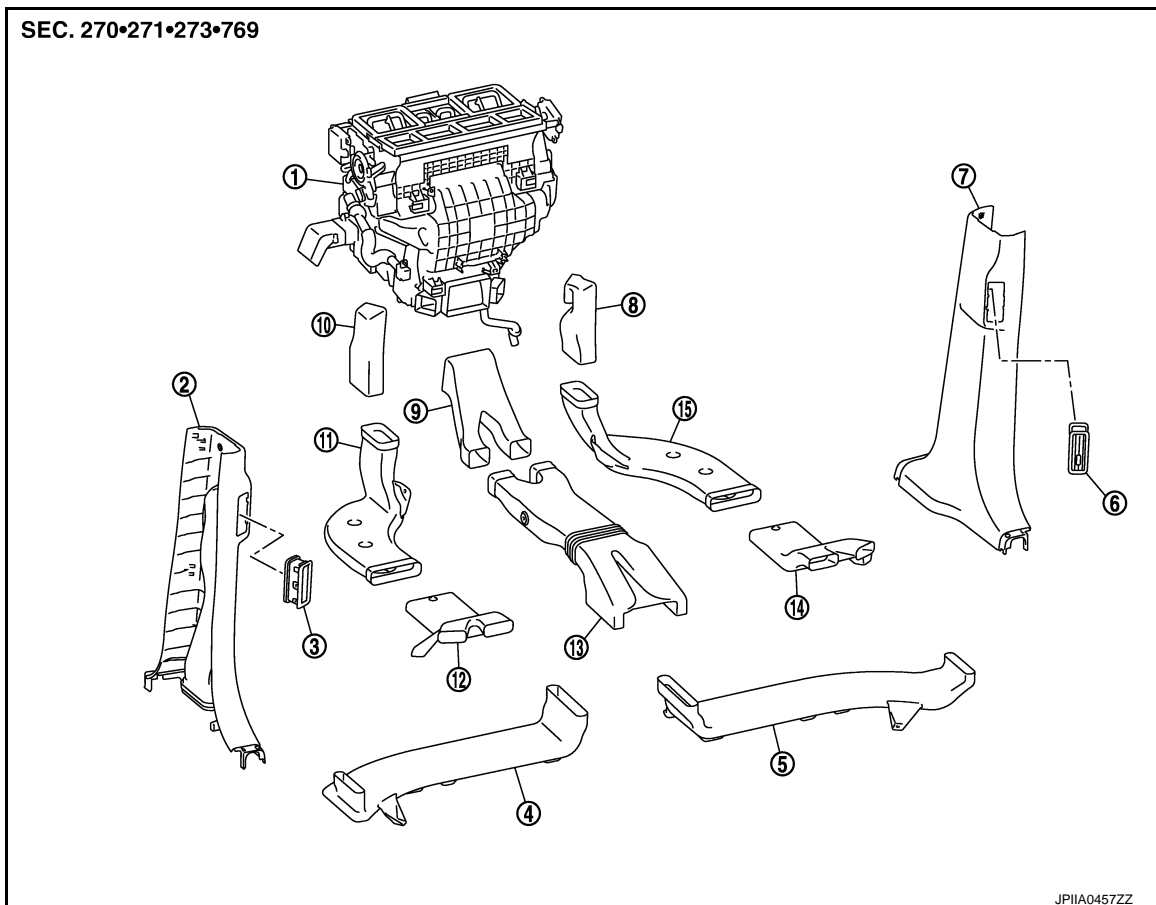

- | | | |
|---|--|-----------------------------------|
| 1. Heater & cooling unit assembly | 2. Rear ventilator duct 4 (center pillar lower garnish left) | 3. Rear ventilator grille (left) |
| 4. Rear ventilator duct 3 (left) | 5. Rear ventilator duct 3 (right) | 6. Rear ventilator grille (right) |
| 7. Rear ventilator duct 4 (center pillar lower garnish right) | 8. Rear foot duct 1 (right) | 9. Rear ventilator duct 1 |
| 10. Rear foot duct 1 (left) | 11. Rear foot duct 2 (left) | 12. Rear foot duct 3 (left) |
| 13. Rear ventilator duct 2 | 14. Rear foot duct 3 (right) | 15. Rear foot duct 2 (right) |

REAR VENTILATOR DUCT 2 : Removal and Installation

INFOID:000000006258673

REMOVAL

1. Remove the front seat assembly (left/right). Refer to [SE-90](#). "Exploded View".
2. Remove the lower console finisher (left/right). Refer to [IP-20](#). "Exploded View".
3. Remove the screws (A), nut (B), and clips (C), and then remove rear ventilator duct 2 (1).

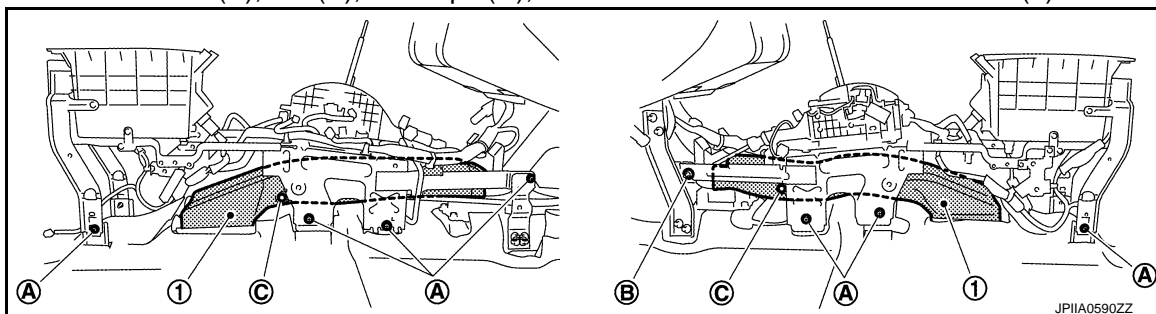

DUCT AND GRILLE

< REMOVAL AND INSTALLATION >

[WITH 7 INCH DISPLAY]

INSTALLATION

Install in the reverse order of removal.

REAR VENTILATOR DUCT 3

REAR VENTILATOR DUCT 3 : Exploded View

INFOID:000000006258674

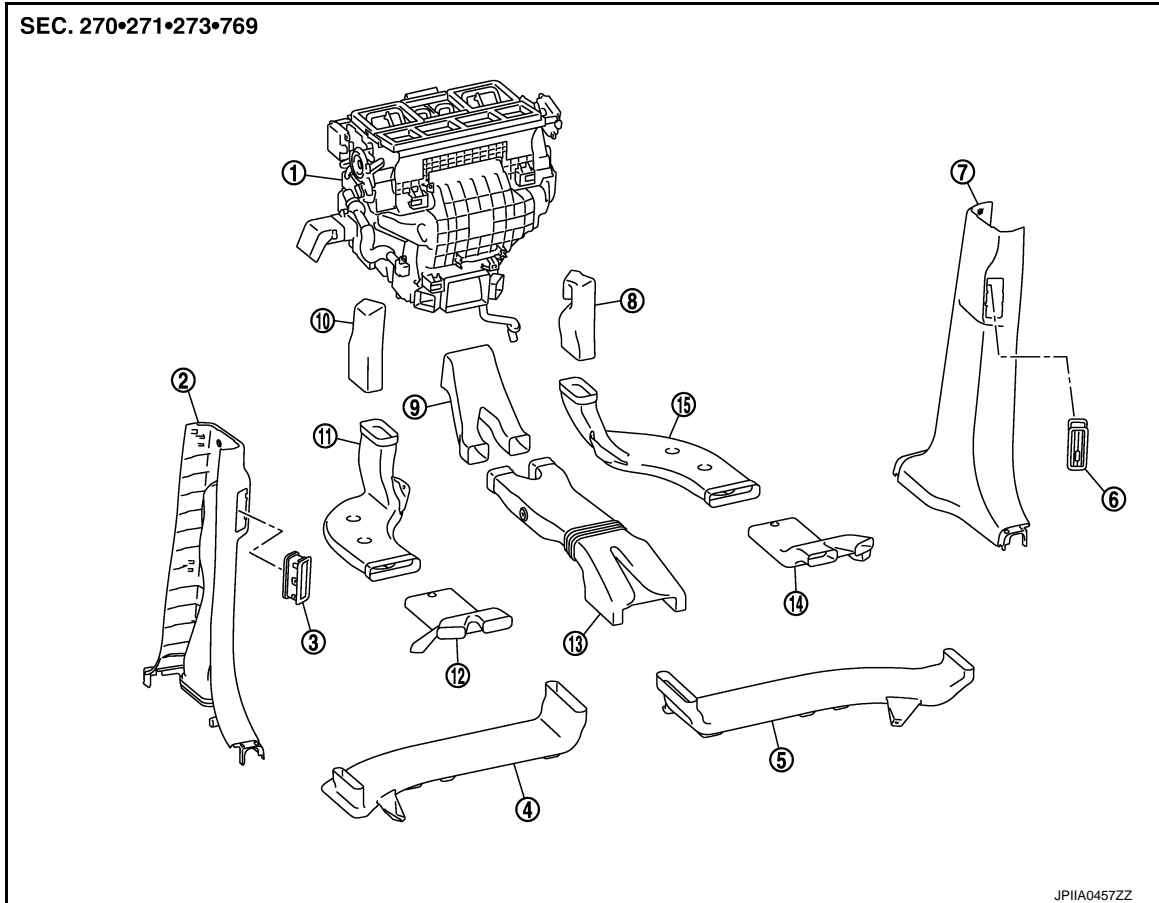

- | | | |
|---|--|-----------------------------------|
| 1. Heater & cooling unit assembly | 2. Rear ventilator duct 4 (center pillar lower garnish left) | 3. Rear ventilator grille (left) |
| 4. Rear ventilator duct 3 (left) | 5. Rear ventilator duct 3 (right) | 6. Rear ventilator grille (right) |
| 7. Rear ventilator duct 4 (center pillar lower garnish right) | 8. Rear foot duct 1 (right) | 9. Rear ventilator duct 1 |
| 10. Rear foot duct 1 (left) | 11. Rear foot duct 2 (left) | 12. Rear foot duct 3 (left) |
| 13. Rear ventilator duct 2 | 14. Rear foot duct 3 (right) | 15. Rear foot duct 2 (right) |

REAR VENTILATOR DUCT 3 : Removal and Installation

INFOID:000000006258675

REMOVAL

Driver side

1. Remove the front seat assembly (left). Refer to [SE-90, "Exploded View"](#).
2. Pull up the driver side floor carpet. Refer to [INT-24, "Exploded View"](#).

DUCT AND GRILLE

< REMOVAL AND INSTALLATION >

[WITH 7 INCH DISPLAY]

3. Remove the mounting screws (A), and then remove rear ventilator duct 3 (left) (1).

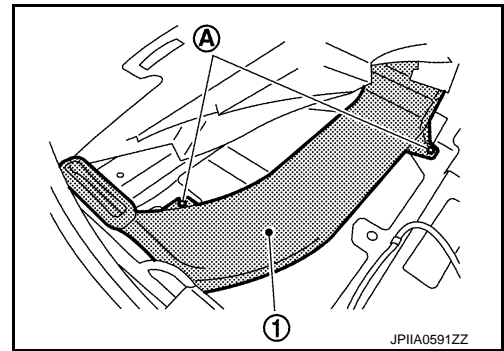

Passenger side

1. Remove the front seat assembly (right). Refer to [SE-90, "Exploded View"](#).
2. Pull up the passenger side floor carpet. Refer to [INT-24, "Exploded View"](#).
3. Remove the mounting screws (A), and then remove rear ventilator duct 3 (right) (1).

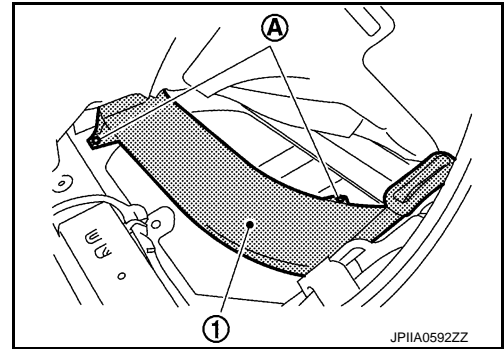

INSTALLATION

Install in the reverse order of removal.

REAR VENTILATOR DUCT 4

A
B
C
D
E
F
G
H
VTL
J
K
L
M
N
O
P

DUCT AND GRILLE

< REMOVAL AND INSTALLATION >

[WITH 7 INCH DISPLAY]

REAR VENTILATOR DUCT 4 : Exploded View

INFOID:000000006258676

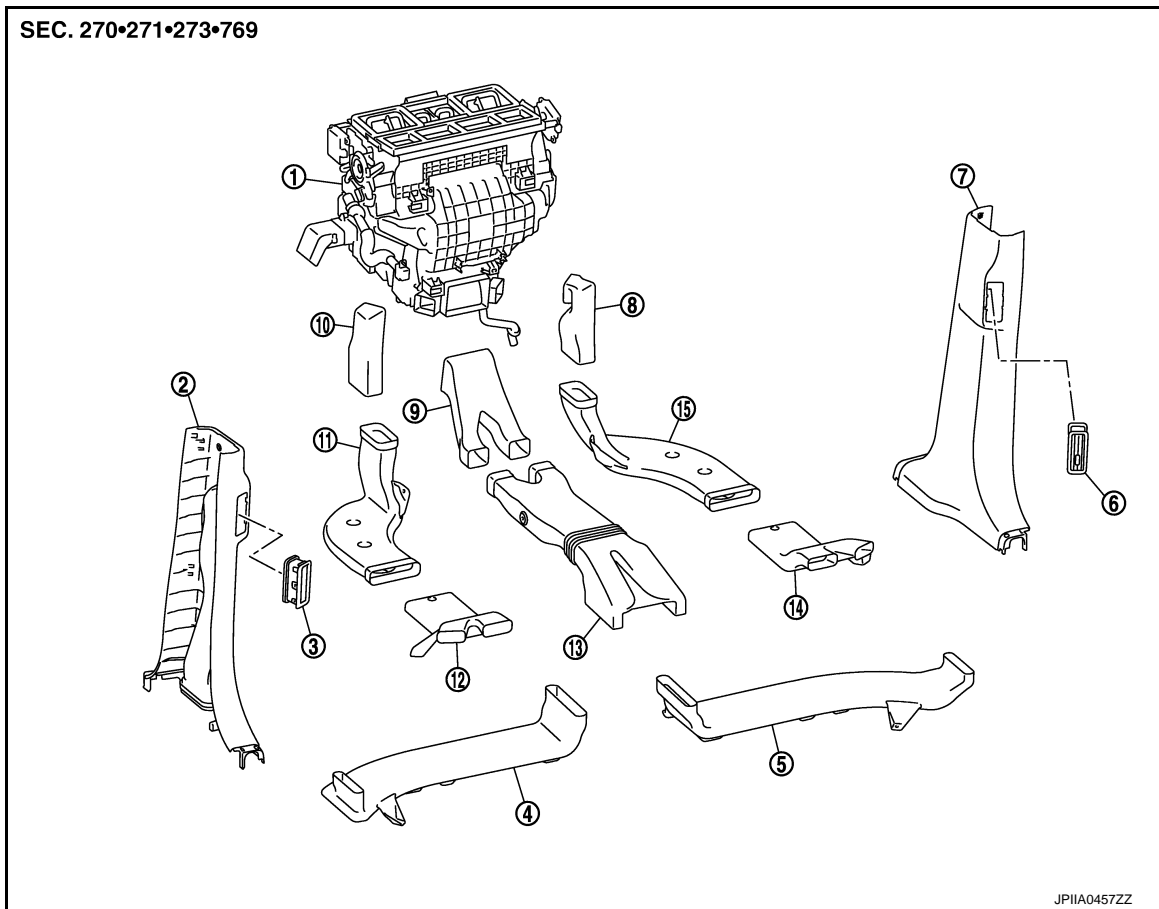

- | | | |
|---|--|-----------------------------------|
| 1. Heater & cooling unit assembly | 2. Rear ventilator duct 4 (center pillar lower garnish left) | 3. Rear ventilator grille (left) |
| 4. Rear ventilator duct 3 (left) | 5. Rear ventilator duct 3 (right) | 6. Rear ventilator grille (right) |
| 7. Rear ventilator duct 4 (center pillar lower garnish right) | 8. Rear foot duct 1 (right) | 9. Rear ventilator duct 1 |
| 10. Rear foot duct 1 (left) | 11. Rear foot duct 2 (left) | 12. Rear foot duct 3 (left) |
| 13. Rear ventilator duct 2 | 14. Rear foot duct 3 (right) | 15. Rear foot duct 2 (right) |

REAR VENTILATOR DUCT 4 : Removal and Installation

INFOID:000000006258677

REMOVAL

1. Remove the center pillar lower garnish (left/right). Refer to [INT-20, "Exploded View"](#).

INSTALLATION

Install in the reverse order of removal.

REAR FOOT DUCT 1

DUCT AND GRILLE

< REMOVAL AND INSTALLATION >

[WITH 7 INCH DISPLAY]

REAR FOOT DUCT 1 : Exploded View

INFOID:000000006258678

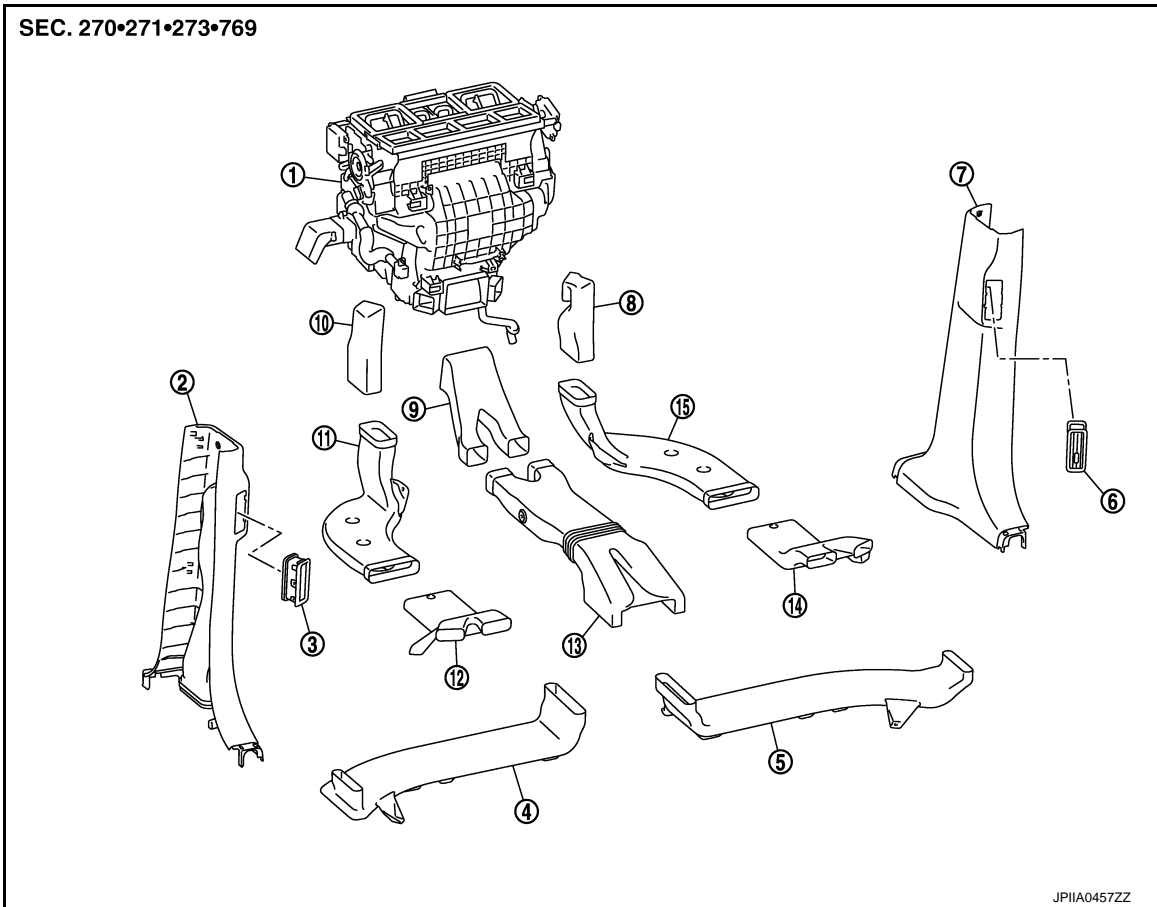

- | | | |
|---|--|-----------------------------------|
| 1. Heater & cooling unit assembly | 2. Rear ventilator duct 4 (center pillar lower garnish left) | 3. Rear ventilator grille (left) |
| 4. Rear ventilator duct 3 (left) | 5. Rear ventilator duct 3 (right) | 6. Rear ventilator grille (right) |
| 7. Rear ventilator duct 4 (center pillar lower garnish right) | 8. Rear foot duct 1 (right) | 9. Rear ventilator duct 1 |
| 10. Rear foot duct 1 (left) | 11. Rear foot duct 2 (left) | 12. Rear foot duct 3 (left) |
| 13. Rear ventilator duct 2 | 14. Rear foot duct 3 (right) | 15. Rear foot duct 2 (right) |

REAR FOOT DUCT 1 : Removal and Installation

INFOID:000000006258679

REMOVAL

Driver side

1. Remove the instrument lower cover LH. Refer to [IP-12, "Exploded View"](#).
2. Remove the rear foot duct 1 (left) (1).

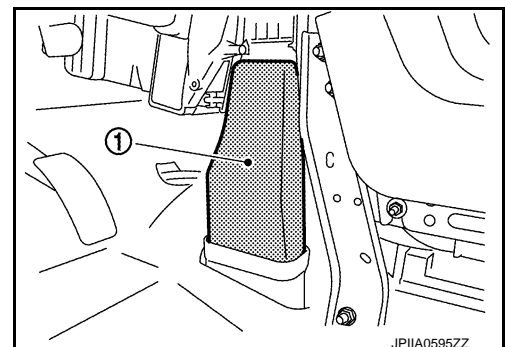

Passenger side

A
B
C
D
E
F
G
H
VTL
J
K
L
M
N
O
P

DUCT AND GRILLE

< REMOVAL AND INSTALLATION >

[WITH 7 INCH DISPLAY]

1. Remove the instrument lower cover RH. Refer to [IP-12. "Exploded View"](#).
2. Remove the rear foot duct 1 (right) (1).

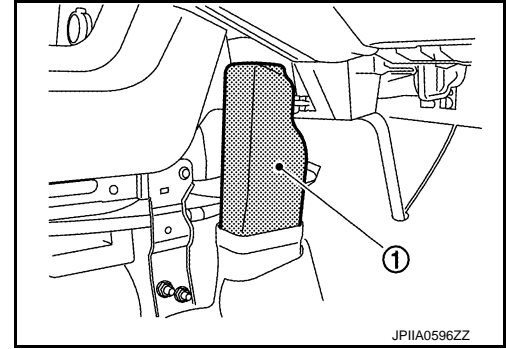

INSTALLATION

Install in the reverse order of removal.

REAR FOOT DUCT 2

REAR FOOT DUCT 2 : Exploded View

INFOID:000000006258680

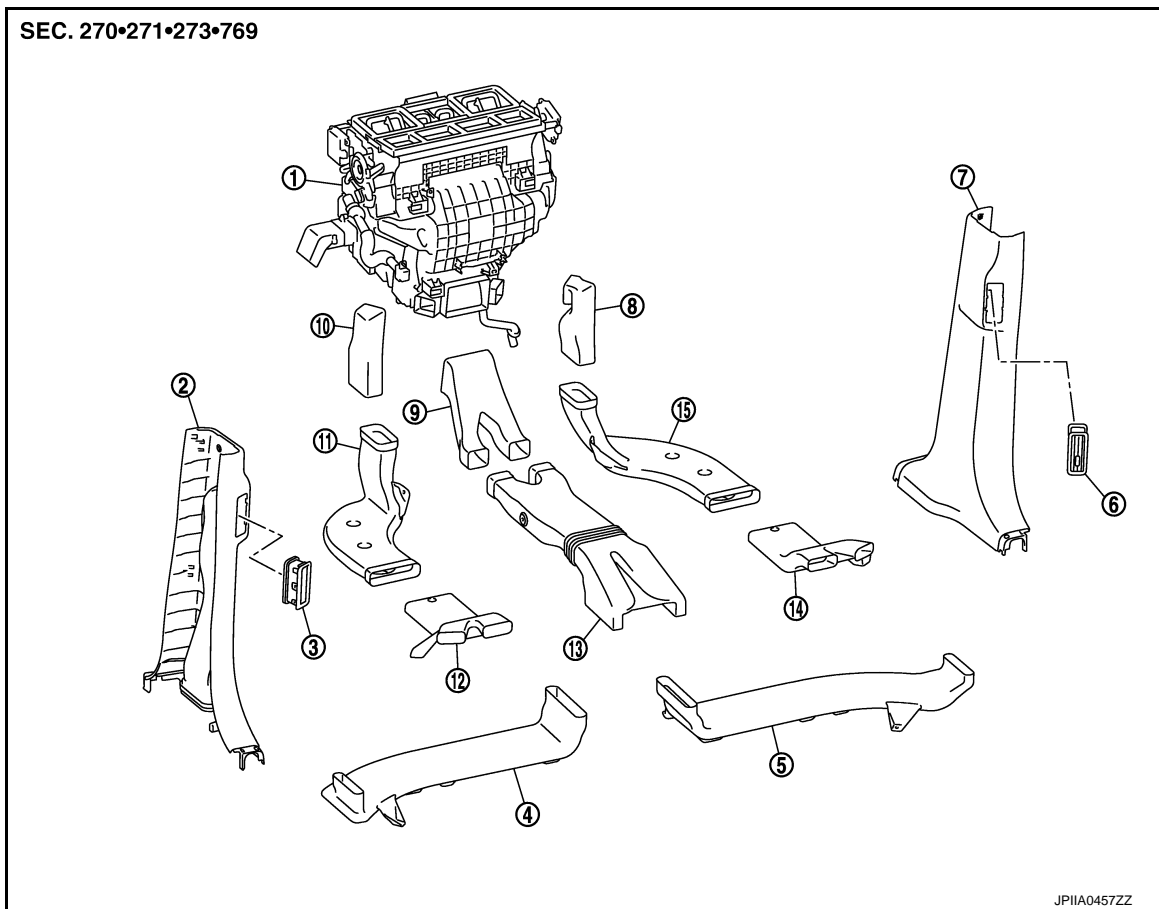

- | | | |
|---|--|-----------------------------------|
| 1. Heater & cooling unit assembly | 2. Rear ventilator duct 4 (center pillar lower garnish left) | 3. Rear ventilator grille (left) |
| 4. Rear ventilator duct 3 (left) | 5. Rear ventilator duct 3 (right) | 6. Rear ventilator grille (right) |
| 7. Rear ventilator duct 4 (center pillar lower garnish right) | 8. Rear foot duct 1 (right) | 9. Rear ventilator duct 1 |
| 10. Rear foot duct 1 (left) | 11. Rear foot duct 2 (left) | 12. Rear foot duct 3 (left) |
| 13. Rear ventilator duct 2 | 14. Rear foot duct 3 (right) | 15. Rear foot duct 2 (right) |

DUCT AND GRILLE

< REMOVAL AND INSTALLATION >

[WITH 7 INCH DISPLAY]

REAR FOOT DUCT 2 : Removal and Installation

INFOID:000000006258681

REMOVAL

Driver side

1. Remove the rear foot duct 1 (left). Refer to [VTL-123, "REAR FOOT DUCT 1 : Exploded View"](#).
2. Pull up the driver side floor carpet. Refer to [INT-24, "Exploded View"](#).
3. Remove the mounting clip (A), and then remove the rear foot duct 2 (left) (1).

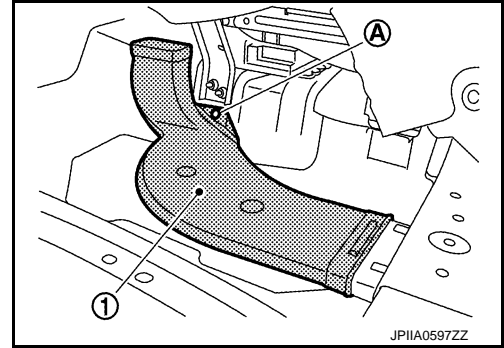

Passenger side

1. Remove the rear foot duct 1 (right). Refer to [VTL-123, "REAR FOOT DUCT 1 : Exploded View"](#).
2. Pull up the passenger side floor carpet. Refer to [INT-24, "Exploded View"](#).
3. Remove the mounting clip (A), and then remove the rear foot duct 2 (right) (1).

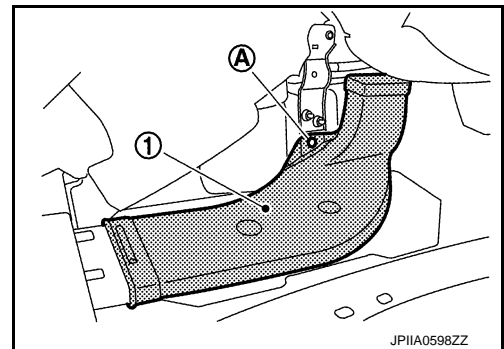

INSTALLATION

Install in the reverse order of removal.

REAR FOOT DUCT 3

A
B
C
D
E
F
G
H
VTL
J
K
L
M
N
O
P

DUCT AND GRILLE

< REMOVAL AND INSTALLATION >

[WITH 7 INCH DISPLAY]

REAR FOOT DUCT 3 : Exploded View

INFOID:000000006258682

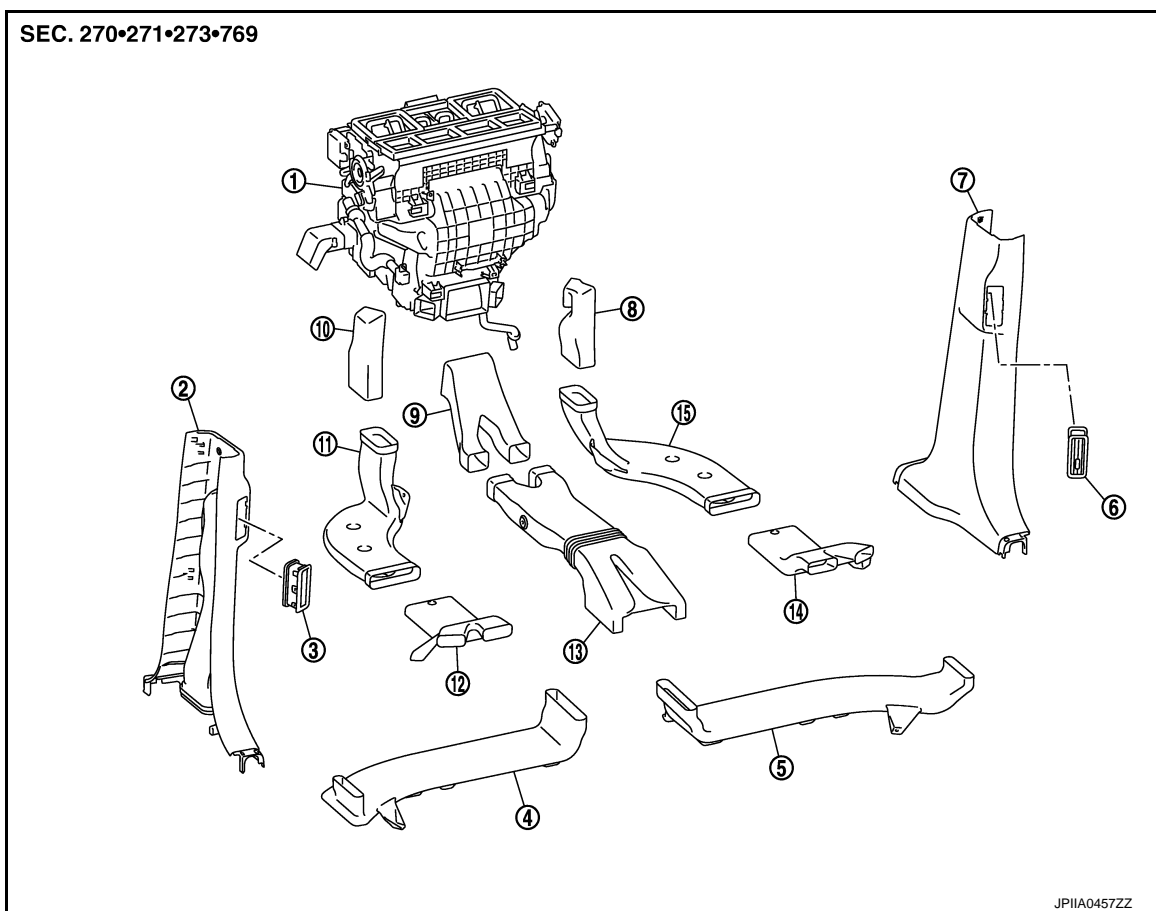

- | | | |
|---|--|-----------------------------------|
| 1. Heater & cooling unit assembly | 2. Rear ventilator duct 4 (center pillar lower garnish left) | 3. Rear ventilator grille (left) |
| 4. Rear ventilator duct 3 (left) | 5. Rear ventilator duct 3 (right) | 6. Rear ventilator grille (right) |
| 7. Rear ventilator duct 4 (center pillar lower garnish right) | 8. Rear foot duct 1 (right) | 9. Rear ventilator duct 1 |
| 10. Rear foot duct 1 (left) | 11. Rear foot duct 2 (left) | 12. Rear foot duct 3 (left) |
| 13. Rear ventilator duct 2 | 14. Rear foot duct 3 (right) | 15. Rear foot duct 2 (right) |

REAR FOOT DUCT 3 : Removal and Installation

INFOID:000000006258683

REMOVAL

Driver side

1. Remove the rear foot duct 2 (left). Refer to [VTL-124, "REAR FOOT DUCT 2 : Exploded View"](#).
2. Remove the mounting screw (A), and then remove the rear foot duct 3 (left) (1).

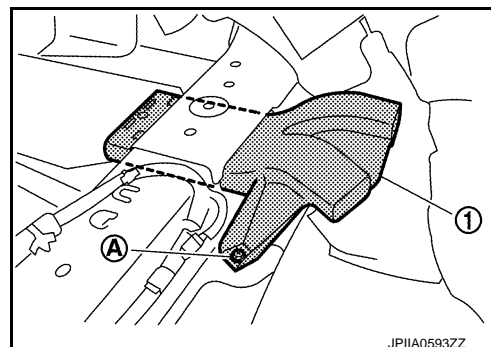

Passenger side

DUCT AND GRILLE

< REMOVAL AND INSTALLATION >

[WITH 7 INCH DISPLAY]

1. Remove the rear foot duct 2 (right). Refer to [VTL-124. "REAR FOOT DUCT 2 : Exploded View"](#).
2. Remove the mounting screw (A), and then remove the rear foot duct 3 (right) (1).

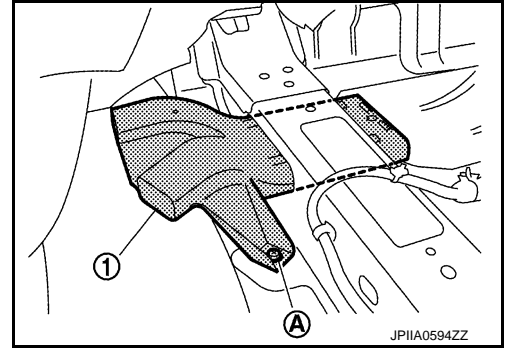

INSTALLATION

Install in the reverse order of removal.

HEATER DUCT

HEATER DUCT : Exploded View

INFOID:000000006258684

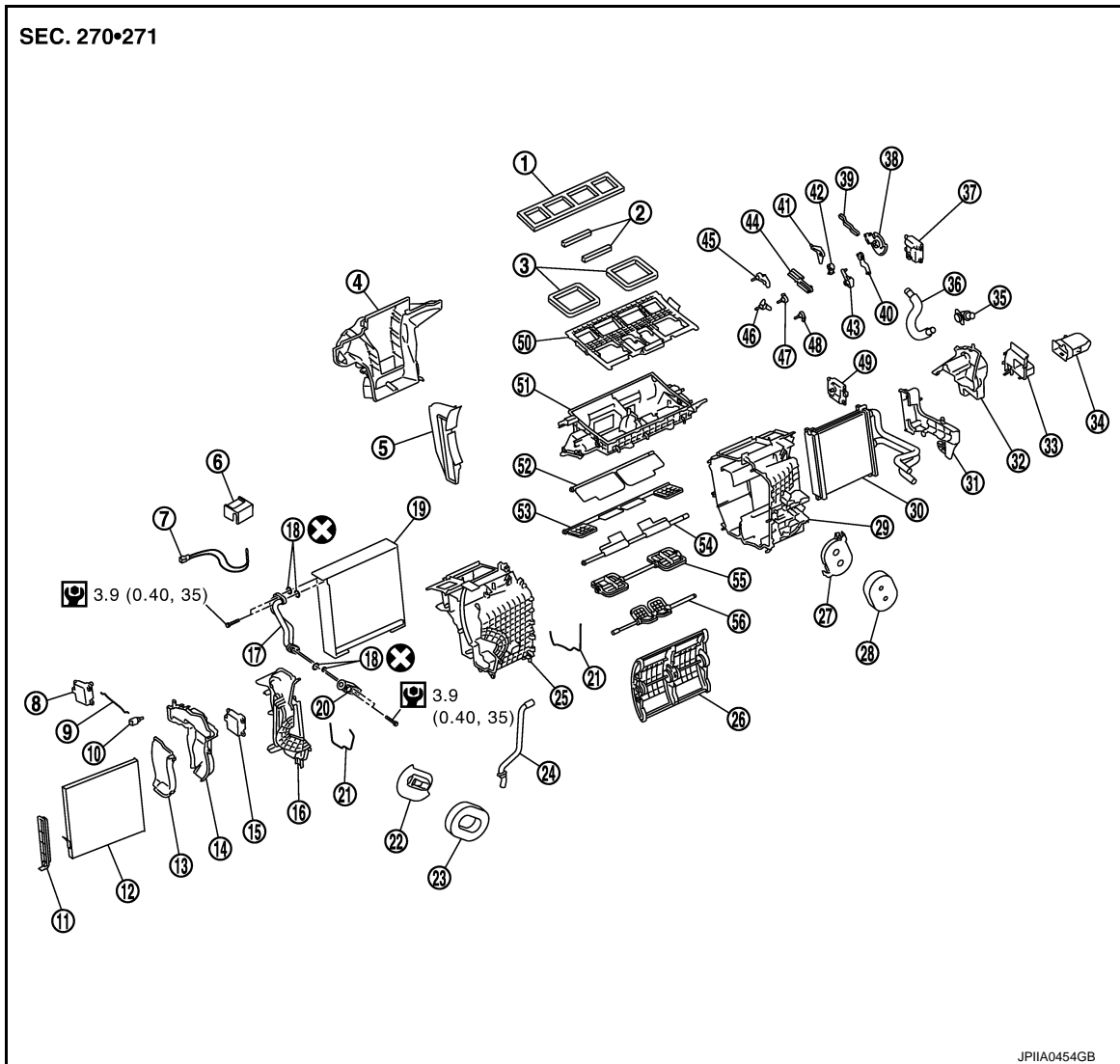

- | | | |
|--------------------|--------------------------------|------------------------------|
| 1. Ventilator seal | 2. Upper ventilator seal | 3. Defroster seal |
| 4. Adapter case | 5. Center case | 6. Intake sensor bracket |
| 7. Intake sensor | 8. Upper ventilator door motor | 9. Upper ventilator door rod |

A
B
C
D
E
F
G
H
VTL
J
K
L
M
N
O
P

DUCT AND GRILLE

< REMOVAL AND INSTALLATION >

[WITH 7 INCH DISPLAY]

- | | | |
|--|---------------------------------------|--|
| 10. Upper ventilator door lever | 11. Filter cover | 12. In-cabin microfilter/Air conditioner filter* |
| 13. Foot duct 1 (right) | 14. Foot duct 2 (right) | 15. Air mix door motor (passenger side) |
| 16. Heater & cooling unit case cover | 17. Evaporator pipe assembly | 18. O-ring |
| 19. Evaporator | 20. Expansion valve | 21. Case packing |
| 22. Grommet | 23. Cooler pipe grommet | 24. Drain hose |
| 25. Heater & cooling unit case (right) | 26. Air mix door (Slide door) | 27. Heater pipe support |
| 28. Heater pipe grommet | 29. Heater & cooling unit case (left) | 30. Heater core |
| 31. Heater pipe cover | 32. Foot duct 2 (left) | 33. Foot duct 1 (left) |
| 34. Heater duct | 35. Aspirator | 36. Aspirator hose |
| 37. Mode door motor | 38. Main link | 39. Rod link |
| 40. Max. cool door link | 41. Ventilator door link | 42. Foot door link |
| 43. Mode door lever | 44. Defroster door link | 45. Ventilator door lever |
| 46. Foot door lever | 47. Defroster door lever | 48. Max. cool door lever |
| 49. Air mix door motor (driver side) | 50. Distributor upper case | 51. Distributor lower case |
| 52. Ventilator door | 53. Foot door | 54. Max. cool door |
| 55. Defroster door | 56. Upper ventilator door | |

* : Models for Mexico.

Refer to [GI-4, "Components"](#) for symbols in the figure.

HEATER DUCT : Removal and Installation

INFOID:000000006258685

REMOVAL

1. Remove the instrument lower panel LH. Refer to [IP-12, "Exploded View"](#).
2. Remove the mounting screw (A), and then remove the heater duct (1).

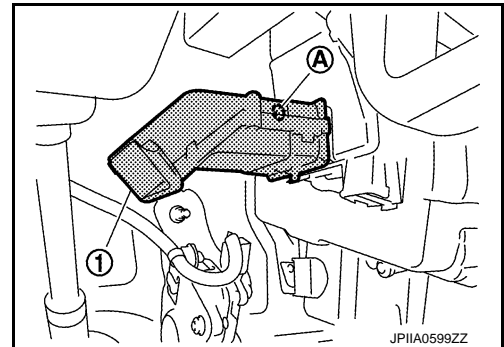

INSTALLATION

Install in the reverse order of removal.

FOOT DUCT

DUCT AND GRILLE

< REMOVAL AND INSTALLATION >

[WITH 7 INCH DISPLAY]

FOOT DUCT : Exploded View

INFOID:000000006258686

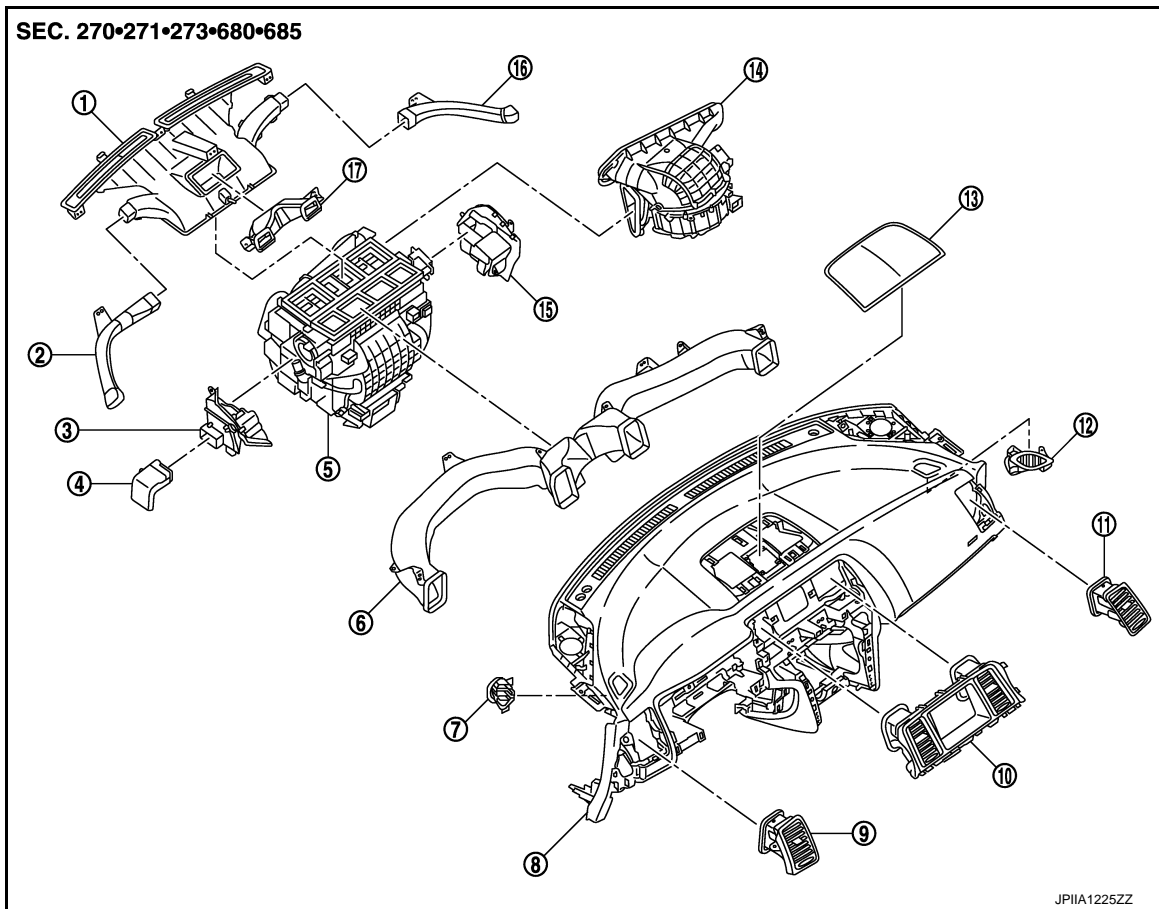

- | | | |
|---------------------------------------|------------------------------------|-----------------------------------|
| 1. Defroster nozzle | 2. Side defroster nozzle (left) | 3. Foot duct (left) |
| 4. Heater duct | 5. Heater & cooling unit assembly | 6. Ventilator duct |
| 7. Side defroster grille (left) | 8. Instrument panel assembly | 9. Side ventilator grille (left) |
| 10. Center ventilator grille assembly | 11. Side ventilator grille (right) | 12. Side defroster grille (right) |
| 13. Center speaker grille | 14. Blower unit assembly | 15. Foot duct (right) |
| 16. Side defroster nozzle (right) | 17. Upper ventilator duct | |

FOOT DUCT : Removal and Installation

INFOID:000000006258687

REMOVAL

Driver side

1. Remove instrument lower panel LH. Refer to [IP-12, "Exploded View"](#).
2. Remove mounting screws (A), and then remove foot duct (left) (1).

← : Vehicle front

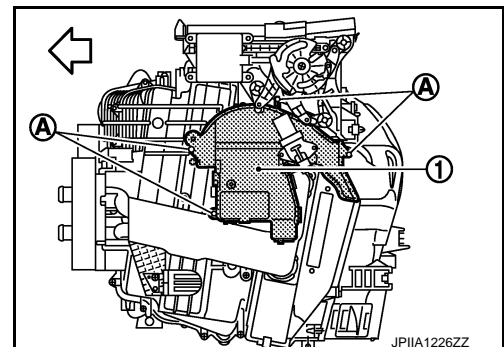

Passenger side

A
B
C
D
E
F
G
H
VTL
J
K
L
M
N
O
P

DUCT AND GRILLE

< REMOVAL AND INSTALLATION >

[WITH 7 INCH DISPLAY]

1. Remove blower unit assembly. Refer to [VTL-92. "Exploded View"](#).
2. Remove mounting screws (A) and harness clip, and then remove foot duct (right) (1).

← : Vehicle front

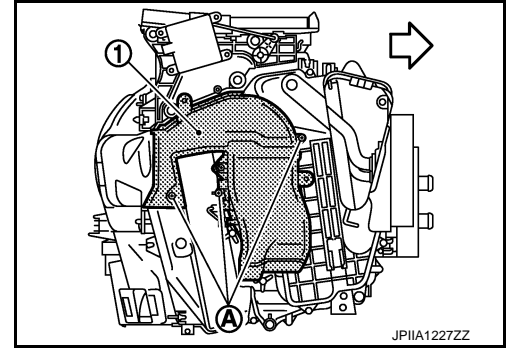

INSTALLATION

Installation is basically the reverse order of removal.