

SECTION **MIR**  
MIRRORS

A  
B  
C  
D  
E  
F  
G  
H  
I  
J  
K  
M  
N  
O  
P

CONTENTS

<b>WITH ADP</b>	
<b>BASIC INSPECTION</b> .....	4
<b>DIAGNOSIS AND REPAIR WORK FLOW</b> .....	4
Work Flow .....	4
<b>SYSTEM DESCRIPTION</b> .....	5
<b>DOOR MIRROR SYSTEM</b> .....	5
System Diagram .....	5
System Description .....	5
Component Parts Location .....	6
Component Description .....	6
<b>INSIDE MIRROR SYSTEM</b> .....	7
System Description .....	7
Component Description .....	7
<b>DIAGNOSIS SYSTEM (DRIVER SEAT CONTROL UNIT)</b> .....	8
Diagnosis Description .....	8
CONSULT Function .....	8
<b>DTC/CIRCUIT DIAGNOSIS</b> .....	11
<b>DOOR MIRROR REMOTE CONTROL SWITCH</b> .....	11
<b>MIRROR SWITCH</b> .....	11
MIRROR SWITCH : Description .....	11
MIRROR SWITCH : Component Function Check... ..	11
MIRROR SWITCH : Diagnosis Procedure .....	11
MIRROR SWITCH : Component Inspection .....	12
<b>CHANGEOVER SWITCH</b> .....	13
CHANGEOVER SWITCH : Description .....	13
CHANGEOVER SWITCH : Component Function Check .....	13
CHANGEOVER SWITCH : Diagnosis Procedure... ..	13
CHANGEOVER SWITCH : Component Inspection .....	14
<b>DOOR MIRROR</b> .....	16
Wiring Diagram - DOOR MIRROR SYSTEM (WITH AUTOMATIC DRIVE POSITIONER) - .....	16
<b>AUTO ANTI-DAZZLING INSIDE MIRROR SYSTEM</b> .....	17
Wiring Diagram - INSIDE MIRROR SYSTEM - .....	17
<b>ECU DIAGNOSIS INFORMATION</b> .....	18
<b>DRIVER SEAT CONTROL UNIT</b> .....	18
Reference Value .....	18
Wiring Diagram - AUTOMATIC DRIVE POSITIONER CONTROL SYSTEM - .....	24
Fail Safe .....	26
DTC Index .....	27
<b>AUTOMATIC DRIVE POSITIONER CONTROL UNIT</b> .....	28
Reference Value .....	28
Wiring Diagram - AUTOMATIC DRIVE POSITIONER CONTROL SYSTEM - .....	31
<b>SYMPTOM DIAGNOSIS</b> .....	34
<b>DOOR MIRROR DOES NOT OPERATE</b> .....	34
Diagnosis Procedure .....	34
<b>SQUEAK AND RATTLE TROUBLE DIAGNOSES</b> .....	35
Work Flow .....	35
Inspection Procedure .....	37
Diagnostic Worksheet .....	39
<b>PRECAUTION</b> .....	41
<b>PRECAUTIONS</b> .....	41
<b>FOR USA AND CANADA</b> .....	41
FOR USA AND CANADA : Precaution for Supplemental Restraint System (SRS) "AIR BAG" and "SEAT BELT PRE-TENSIONER" .....	41

MIR

FOR USA AND CANADA : Precaution for Procedure without Cowl Top Cover .....	41
FOR USA AND CANADA : Precaution for Work ...	41
<b>FOR MEXICO .....</b>	<b>41</b>
FOR MEXICO : Precaution for Supplemental Restraint System (SRS) "AIR BAG" and "SEAT BELT PRE-TENSIONER" .....	41
FOR MEXICO : Precaution for Procedure without Cowl Top Cover .....	42
FOR MEXICO : Precaution for Work .....	42
<b>PREPARATION .....</b>	<b>43</b>
<b>PREPARATION .....</b>	<b>43</b>
Special Service Tools .....	43
Commercial Service Tools .....	43
<b>REMOVAL AND INSTALLATION .....</b>	<b>44</b>
<b>INSIDE MIRROR .....</b>	<b>44</b>
Exploded View .....	44
Removal and Installation .....	44
<b>OUTSIDE MIRROR .....</b>	<b>45</b>
<b>DOOR MIRROR ASSEMBLY .....</b>	<b>45</b>
DOOR MIRROR ASSEMBLY : Exploded View .....	45
DOOR MIRROR ASSEMBLY : Removal and Installation .....	46
<b>GLASS MIRROR .....</b>	<b>46</b>
GLASS MIRROR : Exploded View .....	46
GLASS MIRROR : Disassembly and Assembly .....	46
<b>DOOR MIRROR COVER .....</b>	<b>47</b>
DOOR MIRROR COVER : Exploded View .....	48
DOOR MIRROR COVER : Disassembly and Assembly .....	48
<b>DOOR MIRROR REMOTE CONTROL SWITCH .....</b>	<b>49</b>
Exploded View .....	49
Removal and Installation .....	49
<b>WITHOUT ADP</b>	
<b>SYSTEM DESCRIPTION .....</b>	<b>50</b>
<b>DOOR MIRROR SYSTEM .....</b>	<b>50</b>
Component Description .....	50
<b>INSIDE MIRROR SYSTEM .....</b>	<b>51</b>
System Description .....	51
Component Description .....	51
<b>DTC/CIRCUIT DIAGNOSIS .....</b>	<b>52</b>
<b>DOOR MIRROR .....</b>	<b>52</b>
Wiring Diagram - DOOR MIRROR SYSTEM (WITHOUT AUTOMATIC DRIVE POSITIONER) -..	52

<b>AUTO ANTI-DAZZLING INSIDE MIRROR SYSTEM .....</b>	<b>53</b>
Wiring Diagram - INSIDE MIRROR SYSTEM - .....	53
<b>SYMPTOM DIAGNOSIS .....</b>	<b>54</b>
<b>SQUEAK AND RATTLE TROUBLE DIAGNOSES .....</b>	<b>54</b>
Work Flow .....	54
Inspection Procedure .....	56
Diagnostic Worksheet .....	58
<b>PRECAUTION .....</b>	<b>60</b>
<b>PRECAUTIONS .....</b>	<b>60</b>
<b>FOR USA AND CANADA .....</b>	<b>60</b>
FOR USA AND CANADA : Precaution for Supplemental Restraint System (SRS) "AIR BAG" and "SEAT BELT PRE-TENSIONER" .....	60
FOR USA AND CANADA : Precaution for Procedure without Cowl Top Cover .....	60
FOR USA AND CANADA : Precaution for Work ....	60
<b>FOR MEXICO .....</b>	<b>60</b>
FOR MEXICO : Precaution for Supplemental Restraint System (SRS) "AIR BAG" and "SEAT BELT PRE-TENSIONER" .....	60
FOR MEXICO : Precaution for Procedure without Cowl Top Cover .....	61
FOR MEXICO : Precaution for Work .....	61
<b>PREPARATION .....</b>	<b>62</b>
<b>PREPARATION .....</b>	<b>62</b>
Special Service Tools .....	62
Commercial Service Tools .....	62
<b>REMOVAL AND INSTALLATION .....</b>	<b>63</b>
<b>INSIDE MIRROR .....</b>	<b>63</b>
Exploded View .....	63
Removal and Installation .....	63
<b>OUTSIDE MIRROR .....</b>	<b>64</b>
<b>DOOR MIRROR ASSEMBLY .....</b>	<b>64</b>
DOOR MIRROR ASSEMBLY : Exploded View .....	64
DOOR MIRROR ASSEMBLY : Removal and Installation .....	65
<b>GLASS MIRROR .....</b>	<b>65</b>
GLASS MIRROR : Exploded View .....	65
GLASS MIRROR : Disassembly and Assembly .....	65
<b>DOOR MIRROR COVER .....</b>	<b>66</b>
DOOR MIRROR COVER : Exploded View .....	67
DOOR MIRROR COVER : Disassembly and Assembly .....	67
<b>DOOR MIRROR REMOTE CONTROL SWITCH .....</b>	<b>68</b>

---

Exploded View .....	68	Removal and Installation .....	68
---------------------	----	--------------------------------	----

A

B

C

D

E

F

G

H

I

J

K

**MIR**

M

N

O

P

## BASIC INSPECTION

### DIAGNOSIS AND REPAIR WORK FLOW

#### Work Flow

INFOID:000000007540650

#### DETAILED FLOW

##### 1.OBTAIN INFORMATION ABOUT SYMPTOM

---

Interview the customer to obtain the malfunction information (conditions and environment when the malfunction occurred) as much as possible when the customer brings the vehicle in.

>> GO TO 2.

##### 2.CHECK DTC

---

Perform self-diagnosis for automatic drive positioner (ADP) with CONSULT.

Is any DTC detected?

YES >> Refer to [ADP-127, "DTC Index"](#)

NO >> GO TO 3.

##### 3.REPRODUCE THE MALFUNCTION INFORMATION

---

Check the malfunction on the vehicle that the customer describes.

Inspect the relation of the symptoms and the condition when the symptoms occur.

>> GO TO 4.

##### 4.IDENTIFY THE MALFUNCTIONING SYSTEM WITH "SYMPTOM DIAGNOSIS"

---

Use "Symptom diagnosis" from the symptom inspection result in step 3. Then identify where to start performing the diagnosis based on possible causes and symptoms.

>> GO TO 5.

##### 5.IDENTIFY MALFUNCTIONING PARTS WITH "DTC/CIRCUIT DIAGNOSIS"

---

Perform the diagnosis with "DTC/CIRCUIT DIAGNOSIS" of the applicable system.

>> GO TO 6.

##### 6.REPAIR OR REPLACE THE MALFUNCTIONING PARTS

---

Repair or replace the specified malfunctioning parts.

>> GO TO 7.

##### 7.FINAL CHECK

---

Check that malfunctions are not reproduced when obtaining the malfunction information from the customer, referring to the symptom inspection result in step 3.

Are all malfunctions corrected?

YES >> INSPECTION END

NO >> GO TO 4.

## SYSTEM DESCRIPTION

### DOOR MIRROR SYSTEM

#### System Diagram

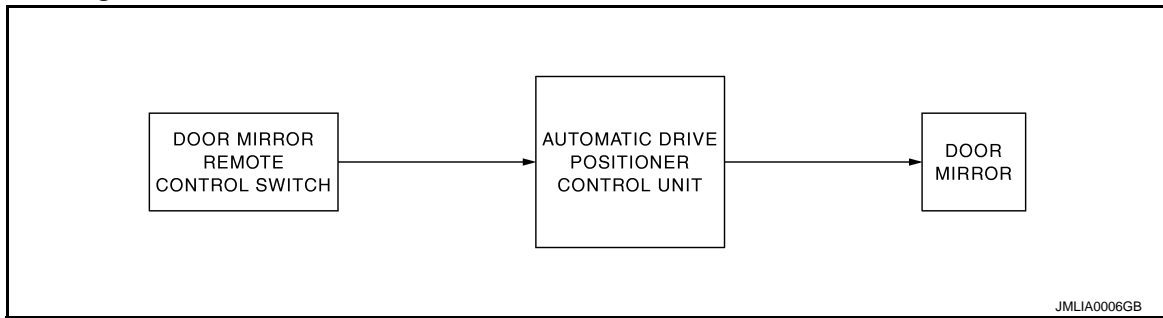

#### System Description

INFOID:000000007540652

##### MANUAL FUNCTION

- Door mirror system is composed of automatic drive positioner, door mirror remote control switch and door mirror.
- Automatic drive positioner control unit controls door mirror.
- Automatic drive positioner control unit receives changeover switch signal and perform the LH/RH control of door mirror motor that supplies electric power when changeover switch is operated.
- Automatic drive positioner control unit receives mirror switch signal and supplies electric power to door mirror motor when mirror switch is operated.
- The door mirrors can be operated manually when ignition switch is in either ACC or ON position. The ignition switch signal (ACC/ON) is transmitted from BCM to the driver seat control unit via CAN communication and from the driver seat control unit to the automatic drive positioner control unit via UART communication.

##### AUTOMATIC DRIVE POSITIONER SYSTEM LINKED OPERATION

Door mirror control is included in automatic drive positioner system. Refer to automatic drive positioner system for more details.

Refer to [ADP-13. "AUTOMATIC DRIVE POSITIONER SYSTEM : System Description"](#).

A  
B  
C  
D  
E  
F  
G  
H  
I  
J  
K

MIR

M  
N  
O  
P

# DOOR MIRROR SYSTEM

< SYSTEM DESCRIPTION >

[WITH ADP]

## Component Parts Location

INFOID:000000007540653

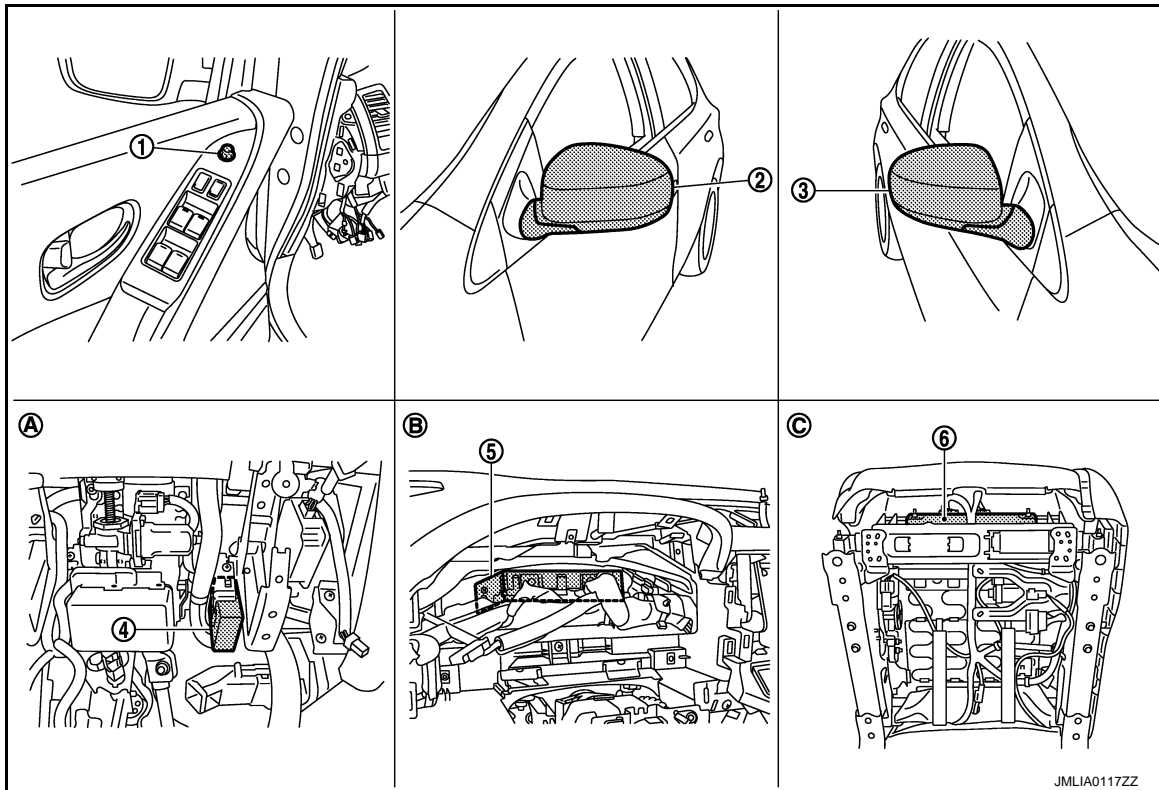

- |  |                                 |                                       |
|--|---------------------------------|---------------------------------------|
| 1. Door mirror remote control switch D14             | 2. Door mirror (driver side) D3 | 3. Door mirror (passenger side) D43   |
| 4. Automatic drive positioner control unit M75, M104 | 5. BCM M118,M119,M122,M123      | 6. Driver seat control unit B451,B452 |
| A. View with instrument driver lower pane removed    | B. Behind the combination meter | C. Backside of the seat cushion       |

## Component Description

INFOID:000000007540654

Component		Function
Automatic drive positioner control unit		Door mirror is supplied with power after receiving the input of the MIRROR SWITCH and CHANGEOVER SWITCH.
Door mirror remote control switch	Mirror switch	It transmits mirror face adjust operation to AUTOMATIC DRIVE POSITIONER CONTROL UNIT.
	Changeover switch	It transmits the LH/RH control of door mirror that supplies power to AUTOMATIC DRIVE POSITIONER CONTROL UNIT.
Door mirror		It makes mirror face operate from side to side and up and down via integrated motor.
BCM		The ignition switch signal (ACC/ON) is transmitted to driver seat control unit via CAN communication.
Driver seat control unit		The ignition switch signal (ACC/ON) is transmitted to automatic drive positioner control unit via UART communication.

# INSIDE MIRROR SYSTEM

[WITH ADP]

< SYSTEM DESCRIPTION >

## INSIDE MIRROR SYSTEM

### System Description

INFOID:000000007540655

The sensor built in inside mirror detects the headlight of the vehicle behind and automatically changes the light transmission to decrease the brightness.

### Component Description

INFOID:000000007540656

Component	Function
Auto anti-dazzling inside mirror	It automatically changes the light transmittance according to the brightness of the light from the headlight of the vehicle behind.

A  
B  
C  
D  
E  
F  
G  
H  
I  
J  
K  
M  
N  
O  
P

MIR

# DIAGNOSIS SYSTEM (DRIVER SEAT CONTROL UNIT)

< SYSTEM DESCRIPTION >

[WITH ADP]

## DIAGNOSIS SYSTEM (DRIVER SEAT CONTROL UNIT)

### Diagnosis Description

INFOID:000000007687745

The auto drive positioner system can be checked and diagnosed for component operation with CONSULT.

### DIAGNOSTIC MODE

Diagnostic mode [AUTO DRIVE POS.]	Description
WORK SUPPORT	Changes the setting of each function.
SELF-DIAG RESULTS	Performs self-diagnosis for the auto drive positioner system and displays the results.
DATA MONITOR	Displays input signals transmitted from various switches and sensors to driver seat control unit in real time.
CAN DIAG SUPPORT MNTR	The result of transmit/receive diagnosis of CAN communication can be read.
ACTIVE TEST	Drive each output device.
ECU IDENTIFICATION	Displays part numbers of driver seat control unit parts.

### CONSULT Function

INFOID:000000007687746

### SELF-DIAGNOSIS RESULTS

Refer to [MIR-27. "DTC Index"](#).

### DATA MONITOR

Monitor Item	Unit	Main Signals	Selection From Menu	Contents
SET SW	"ON/OFF"	×	×	ON/OFF status judged from the setting switch signal.
MEMORY SW 1	"ON/OFF"	×	×	ON/OFF status judged from the seat memory switch 1 signal.
MEMORY SW 2	"ON/OFF"	×	×	ON/OFF status judged from the seat memory switch 2 signal.
SLIDE SW-FR	"ON/OFF"	×	×	ON/OFF status judged from the sliding switch (forward) signal.
SLIDE SW-RR	"ON/OFF"	×	×	ON/OFF status judged from the sliding switch (backward) signal.
RECLN SW-FR	"ON/OFF"	×	×	ON/OFF status judged from the reclining switch (forward) signal.
RECLN SW-RR	"ON/OFF"	×	×	ON/OFF status judged from the reclining switch (backward) signal.
LIFT FR SW-UP	"ON/OFF"	×	×	ON/OFF status judged from the lifting switch front (up) signal.
LIFT FR SW-DN	"ON/OFF"	×	×	ON/OFF status judged from the lifting switch front (down) signal.
LIFT RR SW-UP	"ON/OFF"	×	×	ON/OFF status judged from the lifting switch rear (up) signal.
LIFT RR SW-DN	"ON/OFF"	×	×	ON/OFF status judged from the lifting switch rear (down) signal.
MIR CON SW-UP	"ON/OFF"	×	×	ON/OFF status judged from the mirror switch (up) signal.
MIR CON SW-DN	"ON/OFF"	×	×	ON/OFF status judged from the mirror switch (down) signal.
MIR CON SW-RH	"ON/OFF"	×	×	ON/OFF status judged from the door mirror remote control switch (passenger side) signal.
MIR CON SW-LH	"ON/OFF"	×	×	ON/OFF status judged from the door mirror remote control switch (driver side) signal.



# DIAGNOSIS SYSTEM (DRIVER SEAT CONTROL UNIT)

< SYSTEM DESCRIPTION >

[WITH ADP]

Monitor Item	Unit	Main Signals	Selection From Menu	Contents
MIR CHNG SW-R	"ON/OFF"	×	×	ON/OFF status judged from the door mirror remote control switch (switching to right) signal.
MIR CHNG SW-L	"ON/OFF"	×	×	ON/OFF status judged from the door mirror remote control switch (switching to left) signal.
TILT SW-UP	"ON/OFF"	×	×	ON/OFF status judged from the tilt switch (up) signal.
TILT SW-DOWN	"ON/OFF"	×	×	ON/OFF status judged from the tilt switch (down) signal.
TELESCO SW-FR	"ON/OFF"	×	×	ON/OFF status judged from the telescoping switch (forward) signal.
TELESCO SW-RR	"ON/OFF"	×	×	ON/OFF status judged from the telescoping switch (backward) signal.
DETENT SW	"ON/OFF"	×	×	The selector lever position "OFF (P position) / ON (other than P position)" judged from the detention switch signal.
STARTER SW	"ON/OFF"	×	×	Ignition key switch ON (START, ON) /OFF (ACC, OFF) status judged from the ignition switch signal.
SLIDE PULSE	—	—	×	Value (32768) when battery connections are standard. If it moves backward, the value increases. If it moves forward, the value decreases.
RECLN PULSE	—	—	×	Value (32768) when battery connections are standard. If it moves backward, the value increases. If it moves forward, the value decreases.
LIFT FR PULSE	—	—	×	Value (32768) when battery connections are standard. If it moves DOWN, the value increases. If it moves UP, the value decreases.
LIFT RR PULSE	—	—	×	Value (32768) when battery connections are standard. If it moves DOWN, the value increases. If it moves UP, the value decreases.
MIR/SEN RH U-D	"V"	—	×	Voltage input from door mirror sensor (passenger side) up/down is displayed.
MIR/SEN RH R-L	"V"	—	×	Voltage input from door mirror sensor (passenger side) left/right is displayed.
MIR/SEN LH U-D	"V"	—	×	Voltage input from door mirror sensor (driver side) up/down is displayed.
MIR/SEN LH R-L	"V"	—	×	Voltage input from door mirror sensor (driver side) left/right is displayed.
TILT PULSE	—	—	×	Value (32768) when battery connections are standard. If it moves DOWN, the value increases. If it moves UP, the value decreases.
TELESCO PULSE	—	—	×	Value (32768) when battery connections are standard. If it moves backward, the value increases. If it moves forward, the value decreases.
VEHICLE SPEED	—	×	×	Display the vehicle speed signal received from combination meter by numerical value [km/h].
P RANG SW CAN	"ON/OFF"	×	×	ON/OFF status judged from the P range switch signal.
R RANGE (CAN)	"ON/OFF"	×	×	ON/OFF status judged from the R range switch signal.
DOOR SW-FL	"ON/OFF"	×	×	ON/OFF status judged from the door switch (front driver side) signal.
DOOR SW-FR	"ON/OFF"	×	×	ON/OFF status judged from the door switch (front passenger side) signal.
IGN ON SW	"ON/OFF"	×	×	ON/OFF status judged from the ignition switch signal.
ACC ON SW	"ON/OFF"	×	×	ON/OFF status judged from the ACC switch signal.
KEY ON SW	"ON/OFF"	×	×	ON/OFF status judged from the key on switch signal.

A  
B  
C  
D  
E  
F  
G  
H  
I  
J  
K  
M  
N  
O  
P

MIR

# DIAGNOSIS SYSTEM (DRIVER SEAT CONTROL UNIT)

< SYSTEM DESCRIPTION >

[WITH ADP]

Monitor Item	Unit	Main Signals	Selection From Menu	Contents
KEYLESS ID	—	×	×	Key ID status judged from the key ID signal.
KYLS DR UNLK	“ON/OFF”	×	×	ON/OFF status judged from the driver side door unlock actuator output switch signal.
VHCL SPEED (ABS)	“ON/OFF”	×	×	ON/OFF status judged from vehicle speed signal.
HANDLE	“RHD/LHD”	×	×	RHD/LHD status judged from handle position signal.
TRANSMISSION	“AT or CVT/MT”	×	×	AT or CVT/MT status judged from transmission.
STEERING STATUS	<b>NOTE:</b> This item is displayed, but cannot be monitored			

## ACTIVE TEST

### CAUTION:

**When driving vehicle, do not perform active test.**

Test item	Description
SEAT SLIDE	Activates/deactivates the sliding motor.
SEAT RECLINING	Activates/deactivates the reclining motor.
SEAT LIFTER FR	Activates/deactivates the lifting motor (front).
SEAT LIFTER RR	Activates/deactivates the lifting motor (rear).
TILT MOTOR	Activates/deactivates the tilt motor.
TELESCO MOTOR	Activates/deactivates the telescopic motor.
MIRROR MOTOR RH	Activates/deactivates the mirror motor (passenger side).
MIRROR MOTOR LH	Activates/deactivates the mirror motor (driver side).
MEMORY SW INDCTR	Turns ON/OFF the memory indicator.

## WORK SUPPORT

Work item	Content	Item
SEAT SLIDE VOLUME SET	The amount of seat sliding for entry/exit assist can be selected from 3 items.	40 mm
		80 mm
		150 mm
EXIT TILT SETTING	Entry/exit assist (steering column) can be selected: ON (operated) – OFF (not operated)	ON
		OFF
EXIT SEAT SLIDE SETTING	Entry/exit assist (seat) can be selected: ON (operated) – OFF (not operated)	ON
		OFF

# DOOR MIRROR REMOTE CONTROL SWITCH

< DTC/CIRCUIT DIAGNOSIS >

[WITH ADP]

## DTC/CIRCUIT DIAGNOSIS

### DOOR MIRROR REMOTE CONTROL SWITCH MIRROR SWITCH

#### MIRROR SWITCH : Description

INFOID:000000007540659

It operates angle of the door mirror face.  
It transmits mirror face adjust operation to AUTOMATIC DRIVE POSITIONER CONTROL UNIT.

#### MIRROR SWITCH : Component Function Check

INFOID:000000007540660

#### 1.CHECK MIRROR SWITCH FUNCTION

Check the operation on "MIR CON SW-UP/DN" and "MIR CON SW-RH/LH" in "DATA MONITOR" mode with CONSULT.

Monitor item	Condition	
MIR CON SW-UP/DN	When operating the mirror switch toward the up or down side.	: ON
	Other than above.	: OFF
MIR CON SW-RH/LH	When operating the mirror switch toward the right or left side.	: ON
	Other than above.	: OFF

#### Is the inspection result normal?

- YES >> Mirror switch function is OK.
- NO >> Refer to [MIR-11. "MIRROR SWITCH : Diagnosis Procedure"](#).

#### MIRROR SWITCH : Diagnosis Procedure

INFOID:000000007540661

#### 1.CHECK MIRROR SWITCH INPUT SIGNAL

1. Turn ignition switch OFF.
2. Disconnect door mirror remote control switch connector.
3. Turn ignition switch ON.
4. Check voltage between door mirror remote control switch harness connector and ground.

(+)		(-)	Voltage (V) (Approx.)
Door mirror remote control switch			
Connector	Terminal		
D14	4	Ground	5
	12		
	13		
	15		

#### Is the inspection result normal?

- YES >> GO TO 3.
- NO >> GO TO 2.

#### 2.CHECK MIRROR SWITCH CIRCUIT

1. Turn ignition switch OFF.
2. Disconnect automatic drive positioner control unit connector.
3. Check continuity between automatic drive positioner control unit harness connector and door mirror remote control switch harness connector.

A  
B  
C  
D  
E  
F  
G  
H  
I  
J  
K  
M  
N  
O  
P

MIR

# DOOR MIRROR REMOTE CONTROL SWITCH

< DTC/CIRCUIT DIAGNOSIS >

[WITH ADP]

Automatic drive positioner control unit		Door mirror remote control switch		Continuity
Connector	Terminal	Connector	Terminal	
M75	3	D14	15	Existed
	4		13	
	15		12	
	16		4	

4. Check continuity between automatic drive positioner control unit harness connector and ground.

Automatic drive positioner control unit		Ground	Continuity
Connector	Terminal		
M75	3	Ground	Not existed
	4		
	15		
	16		

Is the inspection result normal?

YES >> Replace automatic drive positioner control unit. Refer to [ADP-182. "Removal and Installation"](#).

NO >> Repair or replace harness.

## 3.CHECK DOOR MIRROR REMOTE CONTROL SWITCH GROUND CIRCUIT

- Turn ignition switch OFF.
- Check continuity between door mirror remote control switch harness connector and ground.

Door mirror remote control switch		Ground	Continuity
Connector	Terminal		
D14	7	Ground	Existed

Is the inspection result normal?

YES >> GO TO 4.

NO >> Repair or replace harness.

## 4.CHECK MIRROR SWITCH

Check door mirror remote control switch (mirror switch).

Refer to [MIR-12. "MIRROR SWITCH : Component Inspection"](#).

Is the inspection result normal?

YES >> GO TO 5.

NO >> Replace door mirror remote control switch (mirror switch). Refer to [MIR-49. "Removal and Installation"](#).

## 5.CHECK INTERMITTENT INCIDENT

Check intermittent incident.

Refer to [GI-44. "Intermittent Incident"](#).

>> INSPECTION END

## MIRROR SWITCH : Component Inspection

INFOID:000000007540662

### 1.CHECK MIRROR SWITCH

- Turn ignition switch OFF.
- Disconnect door mirror remote control switch connector.
- Check continuity between door mirror remote control switch terminals.

# DOOR MIRROR REMOTE CONTROL SWITCH

< DTC/CIRCUIT DIAGNOSIS >

[WITH ADP]

Door mirror remote control switch		Condition	Continuity
Connector	Terminal		
D14	4	RIGHT	Existed
		Other than above	Not existed
	13	LEFT	Existed
		Other than above	Not existed
	15	UP	Existed
		Other than above	Not existed
	12	DOWN	Existed
		Other than above	Not existed

Is the inspection result normal?

YES >> INSPECTION END

NO >> Replace door mirror remote control switch. Refer to [MIR-49. "Removal and Installation"](#).

## CHANGEOVER SWITCH

### CHANGEOVER SWITCH : Description

INFOID:000000007540663

Changeover switch is integrated into door mirror remote control switch.

Changeover switch has three positions (L, N and R).

It changes door mirror motor operation by transmitting control signal to automatic drive positioner control unit.

### CHANGEOVER SWITCH : Component Function Check

INFOID:000000007540664

#### 1. CHECK CHANGEOVER SWITCH FUNCTION

Check the operation on "MIR CHNG SW-R" or "MIR CHNG SW-L" in "DATA MONITOR" mode with CONSULT.

Monitor item	Condition
MIR CHNG SW-R/L	When operating the changeover toward the right or left side. : ON
	Other than above. : OFF

Is the inspection result normal?

YES >> Changeover switch function is OK.

NO >> Refer to [MIR-13. "CHANGEOVER SWITCH : Diagnosis Procedure"](#).

### CHANGEOVER SWITCH : Diagnosis Procedure

INFOID:000000007540665

#### 1. CHECK CHANGEOVER SWITCH INPUT SIGNAL

1. Turn ignition switch OFF.
2. Disconnect door mirror remote control switch connector.
3. Turn ignition switch ON.
4. Check voltage between door mirror remote control switch harness connector and ground.

(+)		(-)	Voltage (V) (Approx.)
Door mirror remote control switch			
Connector	Terminal		
D14	10	Ground	5
	11		

Is the inspection result normal?

YES >> GO TO 3.

NO >> GO TO 2.

#### 2. CHECK CHANGEOVER SWITCH CIRCUIT

# DOOR MIRROR REMOTE CONTROL SWITCH

[WITH ADP]

## < DTC/CIRCUIT DIAGNOSIS >

1. Turn ignition switch OFF.
2. Disconnect automatic drive positioner control unit connector.
3. Check continuity between automatic drive positioner control unit harness connector and door mirror remote control switch harness connector.

Automatic drive positioner control unit		Door mirror remote control switch		Continuity
Connector	Terminal	Connector	Terminal	
M75	2	D14	11	Existed
	14		10	

4. Check continuity between automatic drive positioner control unit harness connector and ground.

Automatic drive positioner control unit		Ground	Continuity
Connector	Terminal		
M75	2		Not existed
	14		

### Is the inspection result normal?

- YES >> Replace automatic drive positioner control unit. Refer to [ADP-182. "Removal and Installation"](#) .  
NO >> Repair or replace harness.

## 3.CHECK DOOR MIRROR REMOTE CONTROL SWITCH GROUND CIRCUIT

1. Turn ignition switch OFF.
2. Check continuity between door mirror remote control switch harness connector and ground.

Door mirror remote control switch		Ground	Continuity
Connector	Terminal		
D14	7		Existed

### Is the inspection result normal?

- YES >> GO TO 4.  
NO >> Repair or replace harness.

## 4.CHECK CHANGEOVER SWITCH

Check door mirror remote control switch (changeover switch).  
Refer to [MIR-14. "CHANGEOVER SWITCH : Component Inspection"](#).

### Is the inspection result normal?

- YES >> GO TO 5.  
NO >> Replace door mirror remote control switch (changeover switch). Refer to [MIR-49. "Removal and Installation"](#).

## 5.CHECK INTERMITTENT INCIDENT

Check intermittent incident.  
Refer to [GI-44. "Intermittent Incident"](#).

>> INSPECTION END

## CHANGEOVER SWITCH : Component Inspection

INFOID:000000007540666

## 1.CHECK CHANGEOVER SWITCH

1. Turn ignition switch OFF.
2. Disconnect door mirror remote control switch connector.
3. Check continuity between door mirror remote control switch terminals.

# DOOR MIRROR REMOTE CONTROL SWITCH

< DTC/CIRCUIT DIAGNOSIS >

[WITH ADP]

Door mirror remote control switch		Condition	Continuity
Connector	Terminal		
D14	10	Changeover switch	LEFT
	11		Other than above
			RIGHT
	7		Other than above

Is the inspection result normal?

YES >> INSPECTION END

NO >> Replace door mirror remote control switch. Refer to [MIR-49. "Removal and Installation"](#).

A  
B  
C  
D  
E  
F  
G  
H  
I  
J  
K  
M  
N  
O  
P

MIR

# DOOR MIRROR

< DTC/CIRCUIT DIAGNOSIS >

[WITH ADP]

## DOOR MIRROR

### Wiring Diagram - DOOR MIRROR SYSTEM (WITH AUTOMATIC DRIVE POSITIONER) -

INFOID:000000007540667

For connector terminal arrangements, harness layouts, and alphabets in a  (option abbreviation; if not described in wiring diagram), refer to [GI-12, "Connector Information"](#).

#### DOOR MIRROR (WITH AUTOMATIC DRIVE POSITIONER)

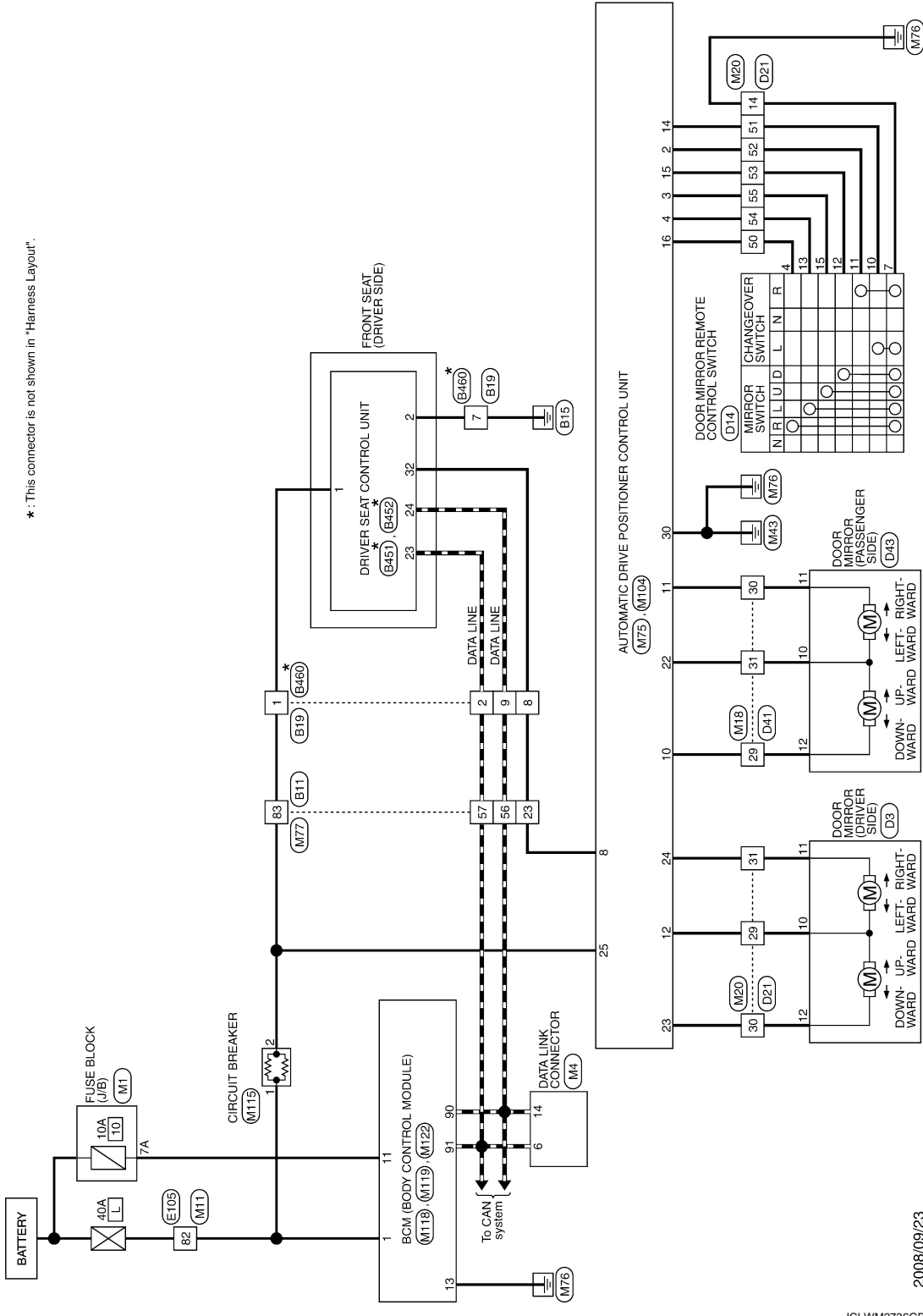



# AUTO ANTI-DAZZLING INSIDE MIRROR SYSTEM

< DTC/CIRCUIT DIAGNOSIS >

[WITH ADP]

## AUTO ANTI-DAZZLING INSIDE MIRROR SYSTEM

### Wiring Diagram - INSIDE MIRROR SYSTEM -

INFOID:000000007540668

For connector terminal arrangements, harness layouts, and alphabets in a  (option abbreviation; if not described in wiring diagram), refer to [GI-12, "Connector Information"](#).

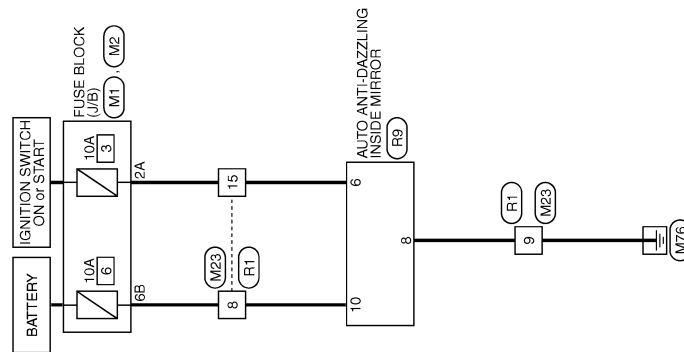

INSIDE MIRROR

2010/09/06

JCLWM6099GB

A  
B  
C  
D  
E  
F  
G  
H  
I  
J  
K  
M  
N  
O  
P

MIR

# DRIVER SEAT CONTROL UNIT

< ECU DIAGNOSIS INFORMATION >

[WITH ADP]

## ECU DIAGNOSIS INFORMATION

### DRIVER SEAT CONTROL UNIT

Reference Value

INFOID:000000007687747

VALUES ON THE DIAGNOSIS TOOL

CONSULT MONITOR ITEM

Monitor Item	Condition	Value/Status	
SET SW	Set switch	Push	ON
		Release	OFF
MEMORY SW1	Memory switch 1	Push	ON
		Release	OFF
MEMORY SW2	Memory switch 2	Push	ON
		Release	OFF
SLIDE SW-FR	Sliding switch (forward)	Operate	ON
		Release	OFF
SLIDE SW-RR	Sliding switch (backward)	Operate	ON
		Release	OFF
RECLN SW-FR	Reclining switch (forward)	Operate	ON
		Release	OFF
RECLN SW-RR	Reclining switch (backward)	Operate	ON
		Release	OFF
LIFT FR SW-UP	Lifting switch front (up)	Operate	ON
		Release	OFF
LIFT FR SW-DN	Lifting switch front (down)	Operate	ON
		Release	OFF
LIFT RR SW-UP	Lifting switch rear (up)	Operate	ON
		Release	OFF
LIFT RR SW-DN	Lifting switch rear (down)	Operate	ON
		Release	OFF
MIR CON SW-UP	Mirror switch	Up	ON
		Other than above	OFF
MIR CON SW-DN	Mirror switch	Down	ON
		Other than above	OFF
MIR CON SW-RH	Mirror switch	Right	ON
		Other than above	OFF
MIR CON SW-LH	Mirror switch	Left	ON
		Other than above	OFF
MIR CHNG SW-R	Changeover switch	Right	ON
		Other than above	OFF
MIR CHNG SW-L	Changeover switch	Left	ON
		Other than above	OFF
TILT SW-UP	Tilt switch	Upward	ON
		Other than above	OFF
TILT SW-DOWN	Tilt switch	Downward	ON
		Other than above	OFF

# DRIVER SEAT CONTROL UNIT

< ECU DIAGNOSIS INFORMATION >

[WITH ADP]

Monitor Item	Condition		Value/Status
TELESCO SW-FR	Telescopic switch	Forward	ON
		Other than above	OFF
TELESCO SW-RR	Telescopic switch	Backward	ON
		Other than above	OFF
DETENT SW	Selector lever	P position	OFF
		Other than above	ON
STARTER SW	Ignition position	Cranking	ON
		Other than above	OFF
SLIDE PULSE	Seat sliding	Forward	The numeral value decreases *
		Backward	The numeral value increases*
		Other than above	No change to numeral value*
RECLN PULSE	Seat reclining	Forward	The numeral value decreases*
		Backward	The numeral value increases *
		Other than above	No change to numeral value *
LIFT FR PULSE	Seat lifter (front)	Up	The numeral value decreases *
		Down	The numeral value increases *
		Other than above	No change to numeral value *
LIFT RR PULSE	Seat lifter (rear)	Up	The numeral value decreases *
		Down	The numeral value increases *
		Other than above	No change to numeral value *
MIR/SEN RH U-D	Door mirror (passenger side)		Change between 3.4 (close to peak) 0.6 (close to valley)
MIR/SEN RH R-L	Door mirror (passenger side)		Change between 3.4 (close to left edge) 0.6 (close to right edge)
MIR/SEN LH U-D	Door mirror (driver side)		Change between 3.4 (close to peak) 0.6 (close to valley)
MIR/SEN LH R-L	Door mirror (driver side)		Change between 0.6 (close to left edge) 3.4 (close to right edge)
TILT PULSE	Tilt position	Upward	The numeral value decreases *
		Downward	The numeral value increases *
		Other than above	No change to numeral value *
TELESCO PULSE	Telescopic position	Forward	The numeral value decreases *
		Backward	The numeral value increases *
		Other than above	No change to numeral value *
STEERING STATUS	<b>NOTE:</b> This item is displayed, but cannot be monitored		
VEHICLE SPEED	The condition of vehicle speed is displayed		km/h
P RANG SW CAN	Selector lever	P position	ON
		Other than above	OFF
R RANGE (CAN)	Selector lever	R position	ON
		Other than above	OFF
DOOR SW-FL	Driver door	Open	ON
		Close	OFF

A  
B  
C  
D  
E  
F  
G  
H  
I  
J  
K  
M  
N  
O  
P

MIR

# DRIVER SEAT CONTROL UNIT

< ECU DIAGNOSIS INFORMATION >

[WITH ADP]

Monitor Item	Condition		Value/Status
DOOR SW-FR	Passenger door	Open	ON
		Close	OFF
IGN ON SW	Ignition switch	ON position	ON
		Other than above	OFF
ACC ON SW	Ignition switch	ACC or ON position	ON
		Other than above	OFF
KEY ON SW	Intelligent Key	Inserted is key slot	ON
		Inserted is not key slot	OFF
KEYLESS ID	UNLOCK button of Intelligent Key is pressed		1,2,3,4or5
KYLS DR UNLK	Intelligent Key or driver side door request switch	ON	ON
		OFF	OFF
VHCL SPEED (ABS)	Can signal from ABS	Received	ON
		Not received	OFF
HANDLE	The BCM for handle position is displayed		LHD
			RHD
TRANSMISSION	Transmission type is displayed		AT or CVT
			MT

\*: The value at the position attained when the battery is connected is regarded as 32768.

## TERMINAL LAYOUT

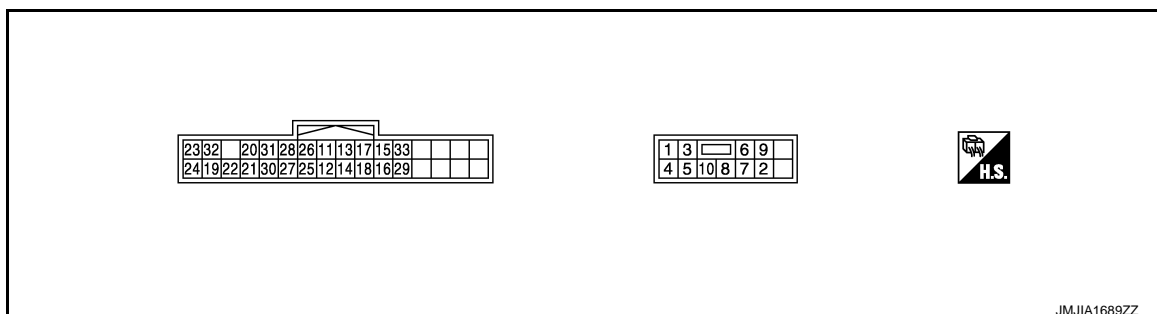

## PHYSICAL VALUES

Terminal No. (wire color)		Description		Condition	Voltage (V) (Approx)	
+	-	Signal name	Input/ Output			
1 (R)	Ground	Power source	Input	—	Battery voltage	
2 (B)	Ground	Ground (power)	—	—	0	
3 (G)	Ground	Sliding motor backward output signal	Output	Seat sliding	Operate (backward)	Battery voltage
					Stop	0
4 (G/R)	Ground	Sliding motor forward output signal	Output	Seat sliding	Operate (forward)	Battery voltage
					Release	0
5 (V)	Ground	Reclining motor backward output signal	Output	Seat reclining	Operate (backward)	Battery voltage
					Stop	0

# DRIVER SEAT CONTROL UNIT

< ECU DIAGNOSIS INFORMATION >

[WITH ADP]

Terminal No. (wire color)		Description		Condition	Voltage (V) (Approx)
+	-	Signal name	Input/ Output		
6 (R/L)	Ground	Reclining motor forward output signal	Output	Seat reclining	Operate (forward) Battery voltage
				Release 0	
7 (L)	Ground	Lifting motor (rear) down output signal	Output	Seat lifting (rear)	Operate (down) Battery voltage
				Stop 0	
8 (L/W)	Ground	Lifting motor (rear) up output signal	Output	Seat lifting (rear)	Operate (up) Battery voltage
				Stop 0	
9 (L/R)	Ground	Lifting motor (front) down output signal	Output	Seat lifting (front)	Operate (down) Battery voltage
				Stop 0	
10 (L/B)	Ground	Lifting motor (front) up output signal	Output	Seat lifting (front)	Operate (up) Battery voltage
				Stop 0	
11 (G/B)	Ground	Sliding switch backward signal	Input	Sliding switch	Operate (backward) 0
				Release Battery voltage	
12 (G/W)	Ground	Sliding switch forward signal	Input	Sliding switch	Operate (forward) 0
				Release Battery voltage	
13 (R/G)	Ground	Reclining switch backward signal	Input	Reclining switch	Operate (backward) 0
				Release Battery voltage	
14 (R/W)	Ground	Reclining switch forward signal	Input	Reclining switch	Operate (forward) 0
				Release Battery voltage	
15 (Y/B)	Ground	Lifting switch (rear) down signal	Input	Lifting switch (rear)	Operate (down) 0
				Release Battery voltage	
16 (Y/R)	Ground	Lifting switch (rear) up signal	Input	Seat lifting switch (rear)	Operate (up) 0
				Release Battery voltage	
17 (LG/B)	Ground	Lifting switch (front) down signal	Input	Lifting switch (front)	Operate (down) 0
				Release Battery voltage	
18 (LG/R)	Ground	Lifting switch (front) up signal	Input	Seat lifting switch (front)	Operate (up) 0
				Release Battery voltage	
19 (G/Y)	Ground	Sliding sensor signal	Input	Seat sliding	Operate 
				Stop 0 or 5	

A  
B  
C  
D  
E  
F  
G  
H  
I  
J  
K  
M  
N  
O  
P

MIR

# DRIVER SEAT CONTROL UNIT

< ECU DIAGNOSIS INFORMATION >

[WITH ADP]

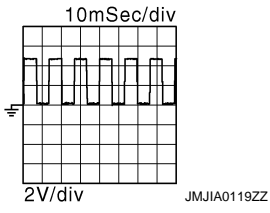
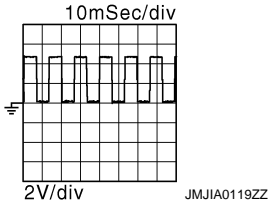
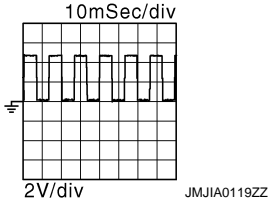
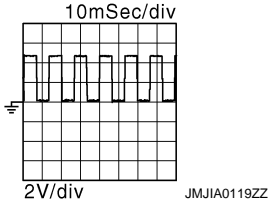
Terminal No. (wire color)		Description		Condition		Voltage (V) (Approx)
+	-	Signal name	Input/ Output			
20 (R/Y)	Ground	Reclining sensor signal	Input	Seat reclining	Operate	
					Stop	0 or 5
21 (L/Y)	Ground	Lifting sensor (rear) signal	Input	Seat lifting (rear)	Operate	
					Stop	0 or 5
22 (BR/Y)	Ground	Lifting sensor (front) signal	Input	Seat lifting (front)	Operate	
					Stop	0 or 5
23 (P)	—	CAN-H	—	—	—	—
24 (P/L)	—	CAN-L	—	—	—	—
25 (G/O)	Ground	Memory indicator 1 signal	Output	Memory indicator 1	Illuminate	1
					Other than above	Battery voltage
26 (L/O)	Ground	Memory indicator 2 signal	Output	Memory indicator 2	Illuminate	1
					Other than above	Battery voltage
27 (V)	Ground	Memory switch 1 signal	Input	Memory switch 1	Press	0
					Other than above	5
28 (V/W)	Ground	Memory switch 2 signal	Input	Memory switch 2	Press	0
					Other than above	5
29 (O/L)	Ground	Set switch signal	Input	Set switch	Press	0
					Other than above	5
30 (BR)	Ground	Tilt sensor signal	Input	Tilt	Operate	
					Other than above	0 or 5

# DRIVER SEAT CONTROL UNIT

< ECU DIAGNOSIS INFORMATION >

[WITH ADP]

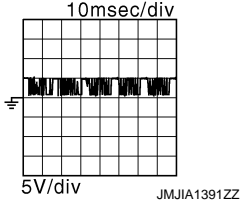
Terminal No. (wire color)		Description		Condition	Voltage (V) (Approx)
+	-	Signal name	Input/ Output		
31 (BR/W)	Ground	Telescopic sensor signal	Input	Telescopic	Operate
					Other than above
32 (W/L)	Ground	UART communication (TX/RX)	Input	Ignition switch ON	
					
33 (W)	Ground	Sensor power supply	Output	—	Battery voltage

A  
B  
C  
D  
E  
F  
G  
H  
I  
J  
K

MIR

M  
N  
O  
P

# DRIVER SEAT CONTROL UNIT

< ECU DIAGNOSIS INFORMATION >

[WITH ADP]

## Wiring Diagram - AUTOMATIC DRIVE POSITIONER CONTROL SYSTEM -

INFOID:000000007687748

For connector terminal arrangements, harness layouts, and alphabets in a  (option abbreviation; if not described in wiring diagram), refer to [GI-12. "Connector Information"](#).

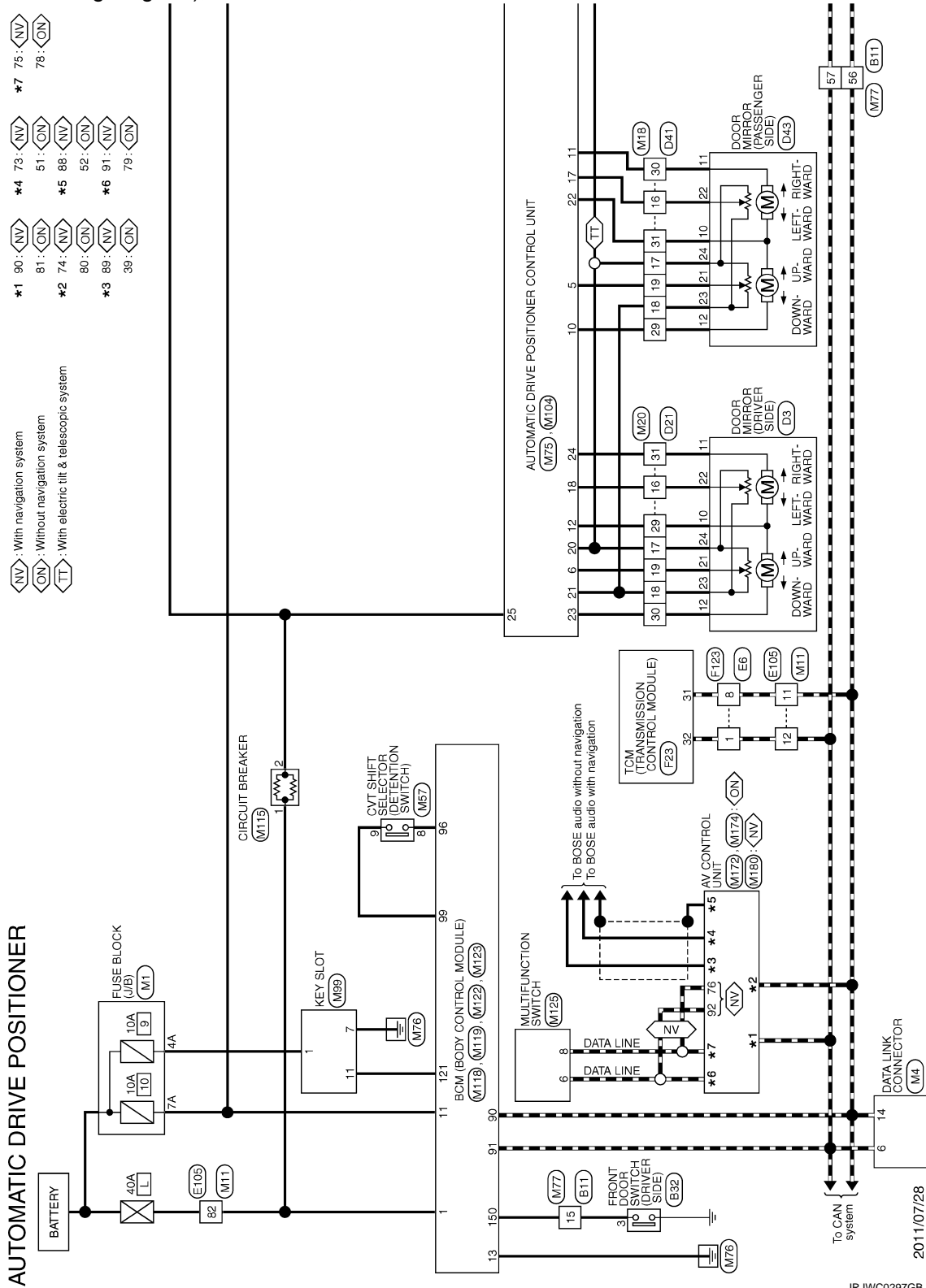

2011/07/28

JR/JWC0297GB



# DRIVER SEAT CONTROL UNIT

< ECU DIAGNOSIS INFORMATION >

[WITH ADP]

Ⓣ : With electric tilt & telescopic system

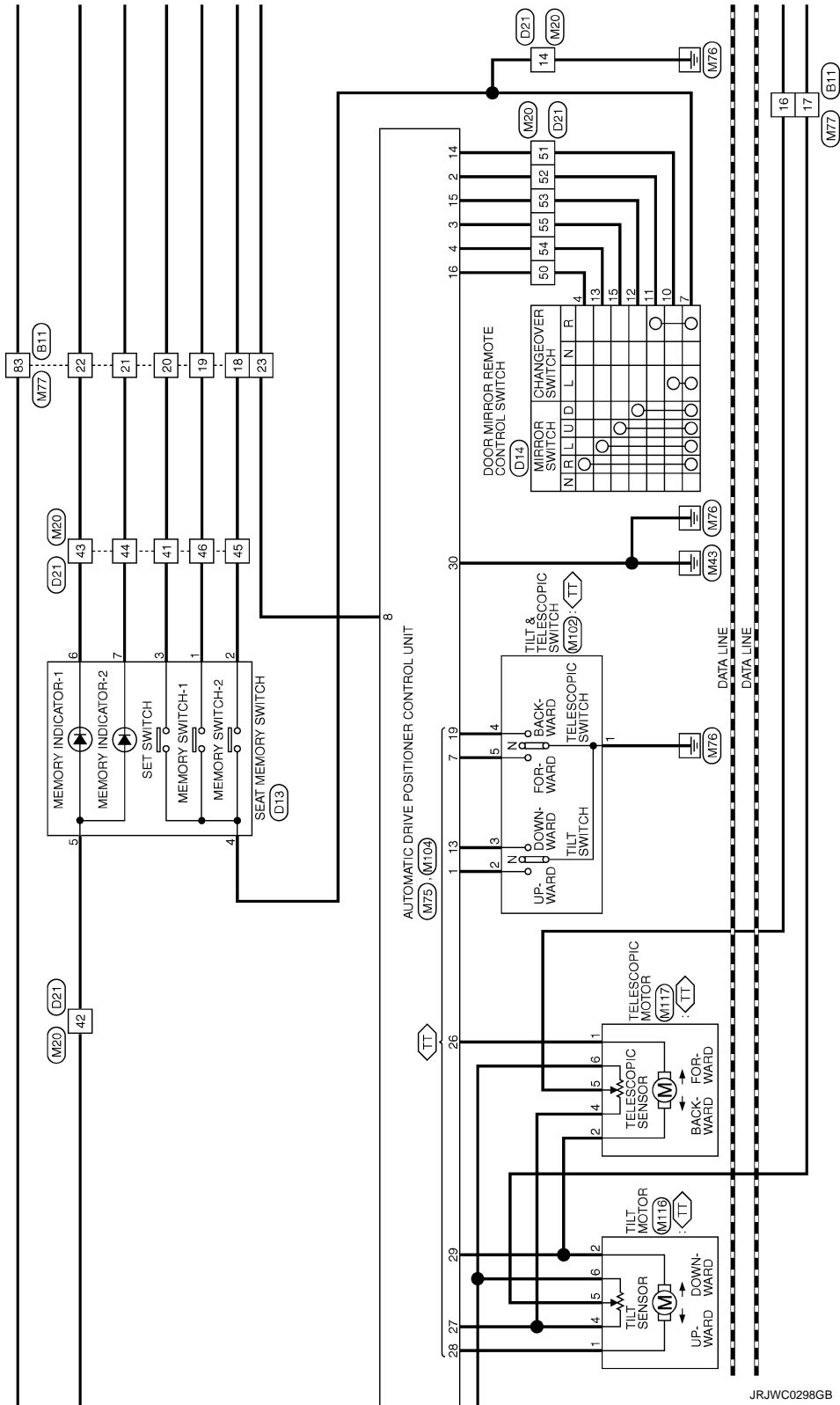

JRJWC0298GB

A  
B  
C  
D  
E  
F  
G  
H  
I  
J  
K  
L  
M  
N  
O  
P

MIR

# DRIVER SEAT CONTROL UNIT

< ECU DIAGNOSIS INFORMATION >

[WITH ADP]

⏏ : With electric tilt & telescopic system  
 \* : This connector is not shown in "Harness Layout".

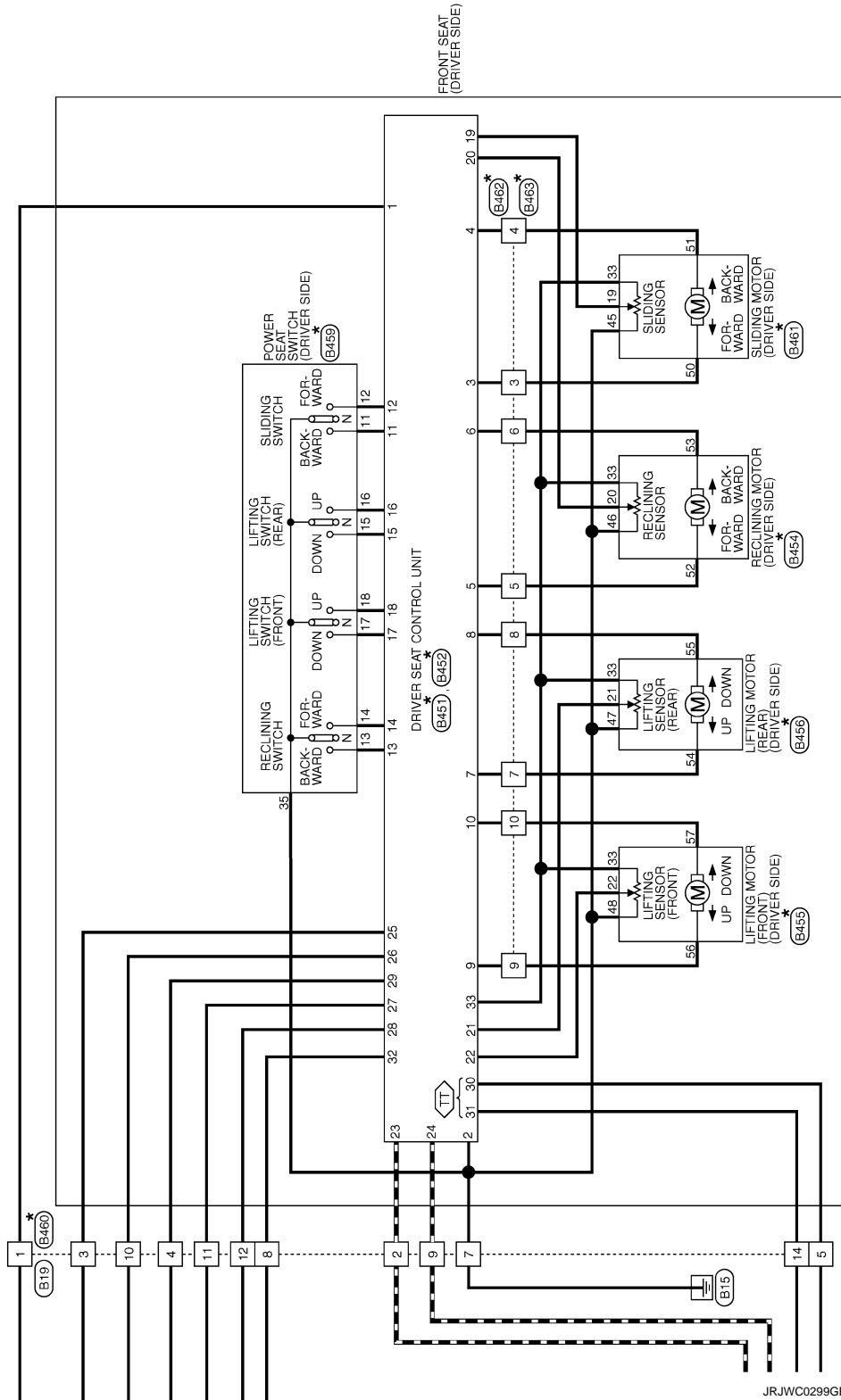

JR.JWC0299GB

## Fail Safe

INFOID:000000007687749

The fail-safe mode may be activated if the following symptoms are observed.

# DRIVER SEAT CONTROL UNIT

< ECU DIAGNOSIS INFORMATION >

[WITH ADP]

Operating in fail-safe mode	Malfunction Item	Related DTC	Diagnosis
Only manual functions operate normally.	CAN communication	U1000	<a href="#">ADP-44</a>
	CONTROL UNIT	U1010	<a href="#">ADP-45</a>
	EEPROM	B2130	<a href="#">ADP-46</a>
Only manual functions, except door mirror, operate normally.	UART communication	B2128	<a href="#">ADP-53</a>
Only manual functions, except seat sliding, operate normally.	Seat sliding output	B2112	<a href="#">ADP-47</a>
Only manual functions, except seat reclining, operate normally.	Seat reclining output	B2113	<a href="#">ADP-49</a>
Only manual functions, except steering tilt, operate normally.	Steering column tilt output	B2116	<a href="#">ADP-51</a>

## DTC Index

INFOID:000000007687750

CONSULT display	Timing*1		Item	Reference page
	Current malfunction	Previous malfunction		
CAN COMM CIRCUIT [U1000]	0	1-39	CAN communication	<a href="#">ADP-44</a>
CONTROL UNIT [U1010]	0	1-39	Control unit	<a href="#">ADP-45</a>
SEAT SLIDE [B2112]	0	1-39	Seat slide motor output	<a href="#">ADP-47</a>
SEAT RECLINING [B2113]	0	1-39	Seat reclining motor output	<a href="#">ADP-49</a>
STEERING TILT [B2116]	0	1-39	Tilt motor output	<a href="#">ADP-51</a>
UART COMM [B2128]	0	1-39	UART communication	<a href="#">ADP-53</a>
EEPROM [B2130]	0	1-39	EEPROM	<a href="#">ADP-46</a>

\*1:

- 0: Current malfunction is present
- 1-39: Displayed if any previous malfunction is present when current condition is normal. The numeral value increases by one at each IGN ON to OFF cycle from 1 to 39. The counter remains at 39 even if the number of cycles exceeds it. However, the counter is reset to 1 if any malfunction is detected again, the normal operation is resumed and the ignition switch is turned from OFF to ON.

# AUTOMATIC DRIVE POSITIONER CONTROL UNIT

< ECU DIAGNOSIS INFORMATION >

[WITH ADP]

## AUTOMATIC DRIVE POSITIONER CONTROL UNIT

Reference Value

INFOID:000000007687751

### TERMINAL LAYOUT

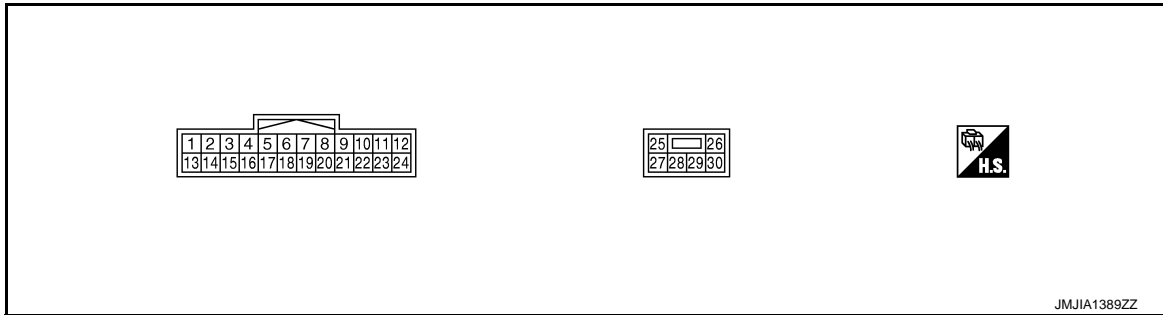

### PHYSICAL VALUES

Terminal No. (wire color)		Description		Condition		Voltage (V) (Approx.)
+	-	Signal name	Input/ Output			
1 (Y)	Ground	Tilt switch up signal	Input	Tilt switch	Operate (up)	0
					Other than above	5
2 (GR)	Ground	Changeover switch RH signal	Input	Changeover switch position	RH	0
					Neutral or LH	5
3 (SB)	Ground	Mirror switch up signal	Input	Mirror switch	Operated (up)	0
					Other than above	5
4 (LG)	Ground	Mirror switch left signal	Input	Mirror switch	Operated (left)	0
					Other than above	5
5 (R)	Ground	Door mirror sensor (passenger side) up/down signal	Input	Door mirror RH position		Change between 3.4 (close to peak) 0.6 (close to valley)
6 (Y)	Ground	Door mirror sensor (driver side) up/down signal	Input	Door mirror LH position		Change between 3.4 (close to peak) 0.6 (close to valley)
7 (P)	Ground	Telescopic switch forward signal	Input	Telescopic switch	Operate (forward)	0
					Other than above	5
8 (LG)	Ground	UART communication (TX/RX)	Output	Ignition switch ON		<p style="text-align: right;">JMJA1391ZZ</p>

# AUTOMATIC DRIVE POSITIONER CONTROL UNIT

< ECU DIAGNOSIS INFORMATION >

[WITH ADP]

Terminal No. (wire color)		Description		Condition		Voltage (V) (Approx.)
+	-	Signal name	Input/ Output			
10 (GR)	Ground	Door mirror motor (pas- senger side) up output signal	Output	Door mirror RH	Operate (up)	Battery voltage
					Other than above	0
11 (G)	Ground	Door mirror motor (pas- senger side) left output signal	Output	Door mirror RH	Operate (left)	Battery voltage
					Other than above	0
12 (R)	Ground	Door mirror motor (driv- er side) down output sig- nal	Output	Door mirror (LH)	Operate (down)	Battery voltage
					Other than above	0
		Door mirror motor (driv- er side) right output sig- nal			Operate (right)	Battery voltage
					Other than above	0
13 (LG)	Ground	Tilt switch down signal	Input	Tilt switch	Operate (down)	0
					Other than above	5
14 (BG)	Ground	Changeover switch LH signal	Input	Changeover switch position	LH	0
					Neutral or RH	5
15 (L)	Ground	Mirror switch down sig- nal	Input	Mirror switch	Operate (down)	0
					Other than above	5
16 (V)	Ground	Mirror switch right signal	Input	Mirror switch	Operate (right)	0
					Other than above	5
17 (W)	Ground	Door mirror sensor (pas- senger side) left/right signal	Input	Door mirror RH position		Change between 3.4 (close to left edge) 0.6 (close to right edge)
18 (L)	Ground	Door mirror sensor (driv- er side) left/right signal	Input	Door mirror LH position		Change between 0.6 (close to left edge) 3.4 (close to right edge)
19 (G)	Ground	Telescopic switch back- ward signal	Input	Telescopic switch	Operate (back- ward)	0
					Other than above	5
20 (Y)	Ground	Ground	—	—		0
21 (W)	Ground	Door mirror motor sen- sor power supply	Input	—		5

A  
B  
C  
D  
E  
F  
G  
H  
I  
J  
K  
M  
N  
O  
P

MIR

# AUTOMATIC DRIVE POSITIONER CONTROL UNIT

< ECU DIAGNOSIS INFORMATION >

[WITH ADP]

Terminal No. (wire color)		Description		Condition	Voltage (V) (Approx.)	
+	-	Signal name	Input/ Output			
22 (V)	Ground	Door mirror motor (passenger side) down output signal	Output	Door mirror (RH)	Operate (down)	Battery voltage
					Other than above	0
		Door mirror motor (passenger side) right output signal			Operate (right)	Battery voltage
					Other than above	0
23 (L)	Ground	Door mirror motor (driver side)up output signal	Output	Door mirror (LH)	Operate (up)	Battery voltage
					Other than above	0
24 (SB)	Ground	Door mirror motor (driver side)left output signal	Output	Door mirror (LH)	Operate (left)	Battery voltage
					Other than above	0
25 (W)	Ground	Power source	Input	—	Battery voltage	
26 (L)	Ground	Telescopic motor backward output signal	Output	Steering telescopic	Operate (backward)	Battery voltage
					Other than above	0
27 (P)	Ground	Tilt&telescopic motor power source		—	Battery voltage	
28 (G)	Ground	Tilt motor down output signal	Output	Steering tilt	Operate (down)	Battery voltage
					Other than above	0
29 (LG)	Ground	Tilt motor up output signal	Output	Steering tilt	Operate (up)	Battery voltage
					Other than above	0
		Telescopic motor forward output signal		Steering telescopic	Operate (forward)	Battery voltage
					Other than above	0
30 (B)	Ground	Ground	—	—	0	

# AUTOMATIC DRIVE POSITIONER CONTROL UNIT

< ECU DIAGNOSIS INFORMATION >

[WITH ADP]

## Wiring Diagram - AUTOMATIC DRIVE POSITIONER CONTROL SYSTEM -

INFOID:000000007688437

For connector terminal arrangements, harness layouts, and alphabets in a ◊ (option abbreviation; if not described in wiring diagram), refer to [GI-12. "Connector Information"](#).

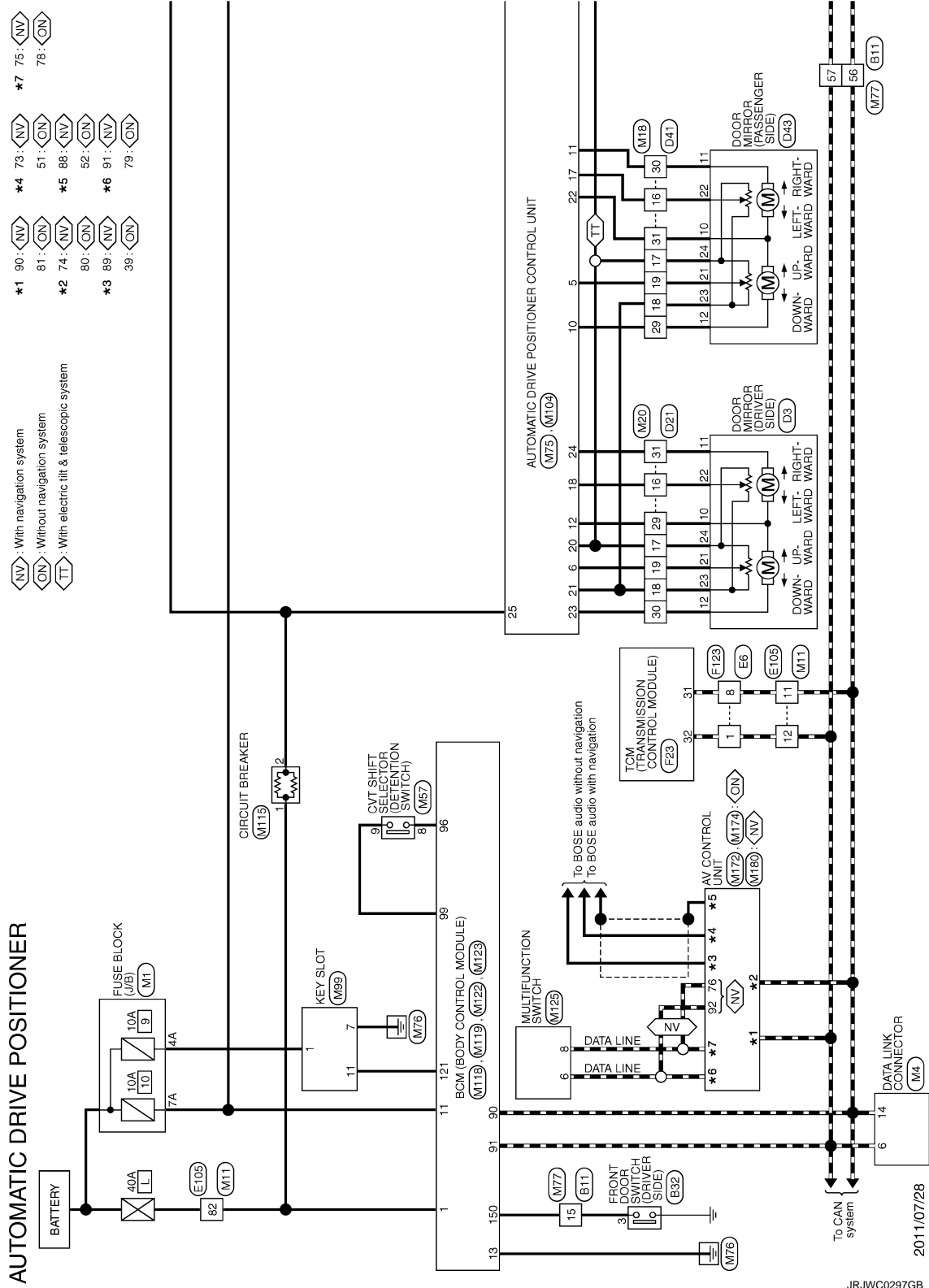

A  
B  
C  
D  
E  
F  
G  
H  
I  
J  
K  
L  
M  
N  
O  
P

MIR

# AUTOMATIC DRIVE POSITIONER CONTROL UNIT

< ECU DIAGNOSIS INFORMATION >

[WITH ADP]

⊡ : With electric tilt & telescopic system

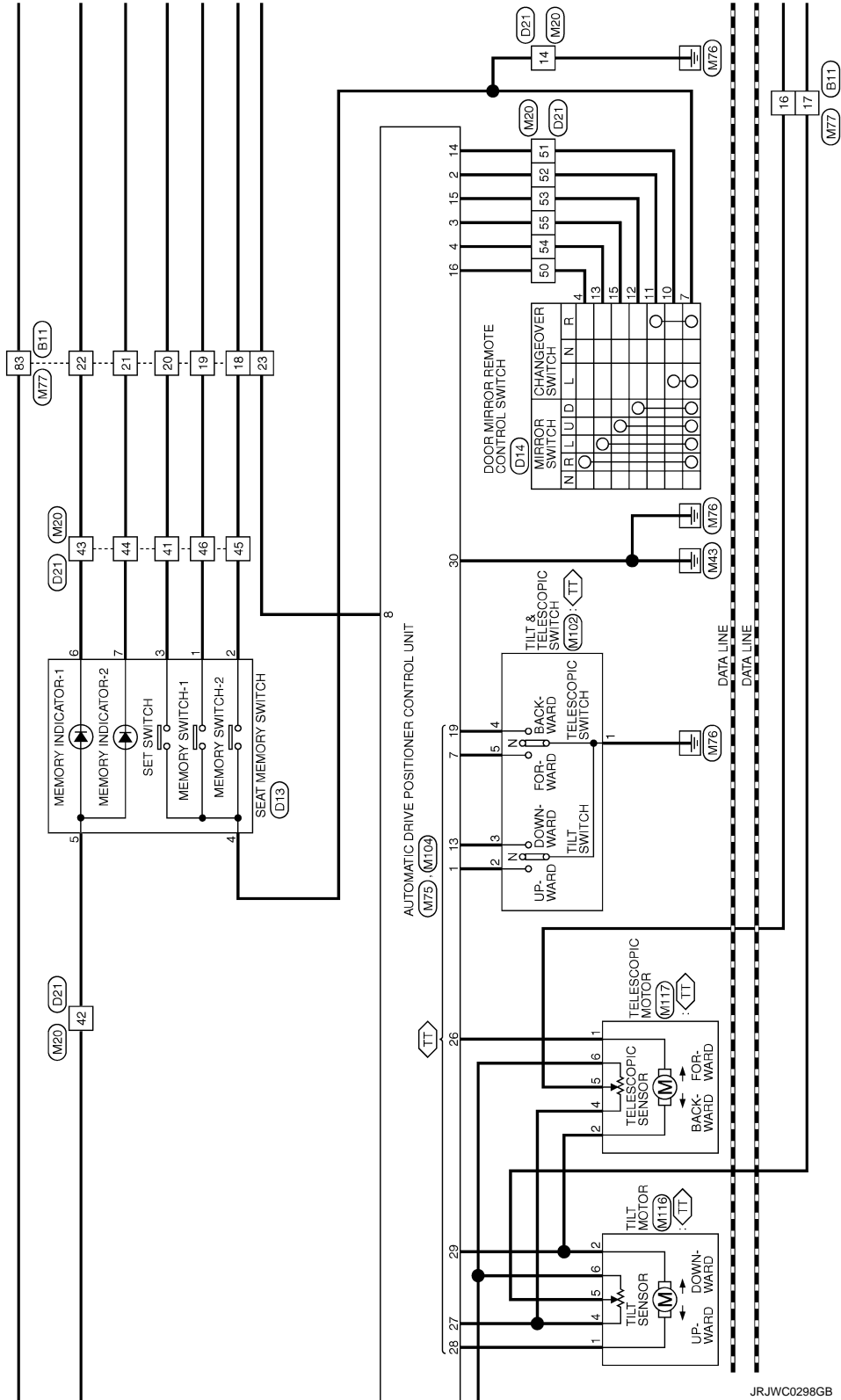

JR.JWC0298GB



# AUTOMATIC DRIVE POSITIONER CONTROL UNIT

< ECU DIAGNOSIS INFORMATION >

[WITH ADP]

⏏ : With electric tilt & telescopic system  
 \* : This connector is not shown in "Harness Layout".

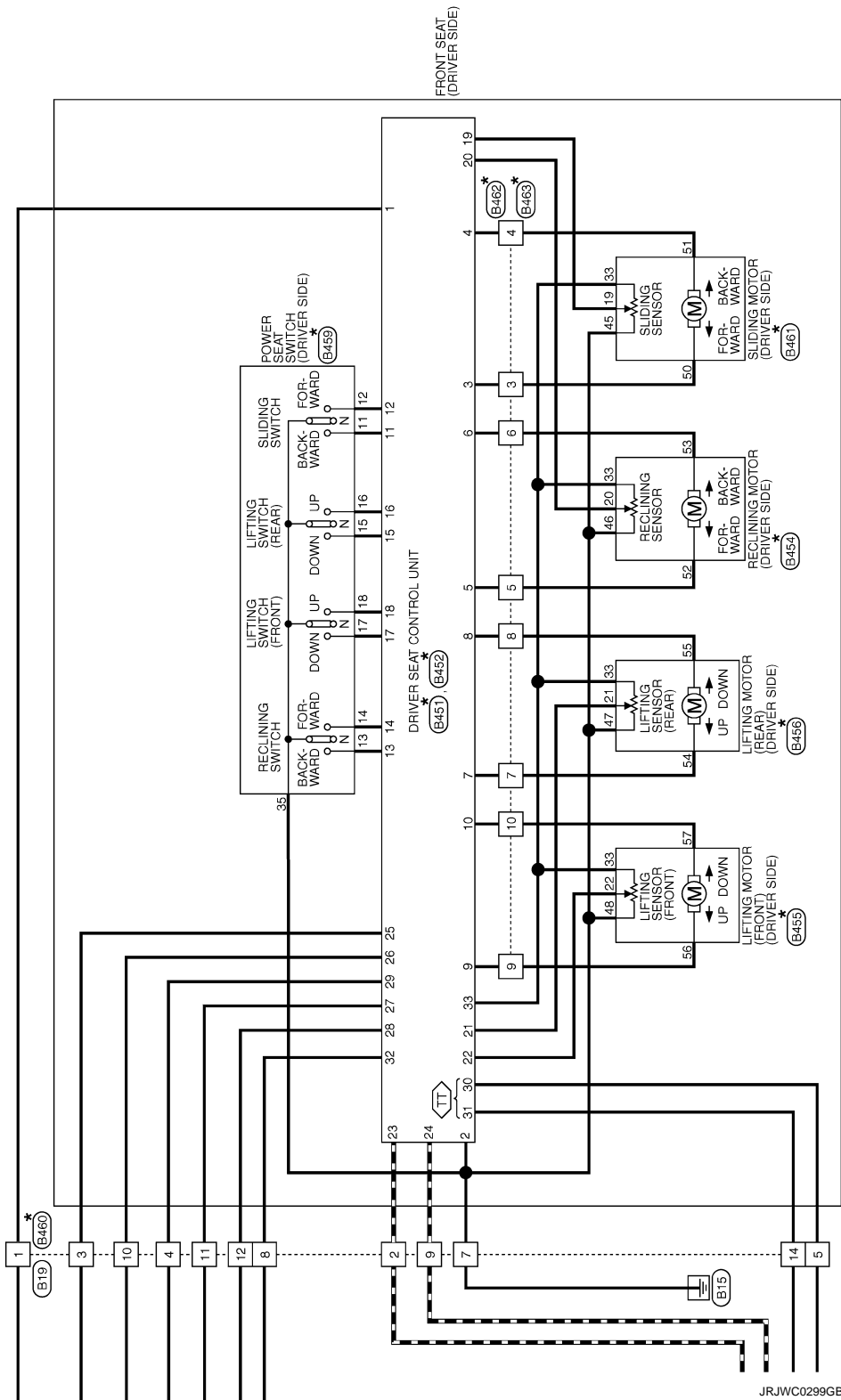

A  
B  
C  
D  
E  
F  
G  
H  
I  
J  
K  
L  
M  
N  
O  
P

MIR

# DOOR MIRROR DOES NOT OPERATE

[WITH ADP]

< SYMPTOM DIAGNOSIS >

## SYMPTOM DIAGNOSIS

### DOOR MIRROR DOES NOT OPERATE

#### Diagnosis Procedure

INFOID:000000007540675

#### 1.CHECK AUTOMATIC DRIVE POSITIONER SYSTEM

---

Check door mirror operate with automatic drive positioner system.

Is the inspection result normal?

YES >> GO TO 2.

NO >> Check automatic drive positioner system operation. Refer to [ADP-13. "AUTOMATIC DRIVE POSITIONER SYSTEM : System Description"](#)

#### 2.CHECK MIRROR SWITCH

---

Check door mirror remote control switch (mirror switch).

Refer to [MIR-11. "MIRROR SWITCH : Component Function Check"](#)

Is the inspection result normal?

YES >> GO TO 3.

NO >> Repair or replace the malfunctioning parts.

#### 3.CHECK CHANGEOVER SWITCH

---

Check door mirror remote control switch (changeover switch).

Refer to [MIR-13. "CHANGEOVER SWITCH : Component Function Check"](#)

Is the inspection result normal?

YES >> GO TO 4.

NO >> Repair or replace the malfunctioning parts.

#### 4.CONFIRM THE OPERATION

---

Confirm the operation again.

Is the result normal?

YES >> Check intermittent incident. Refer to [GI-44. "Intermittent Incident"](#)

NO >> GO TO 1.

# SQUEAK AND RATTLE TROUBLE DIAGNOSES

< SYMPTOM DIAGNOSIS >

[WITH ADP]

## SQUEAK AND RATTLE TROUBLE DIAGNOSES

### Work Flow

INFOID:000000007540676

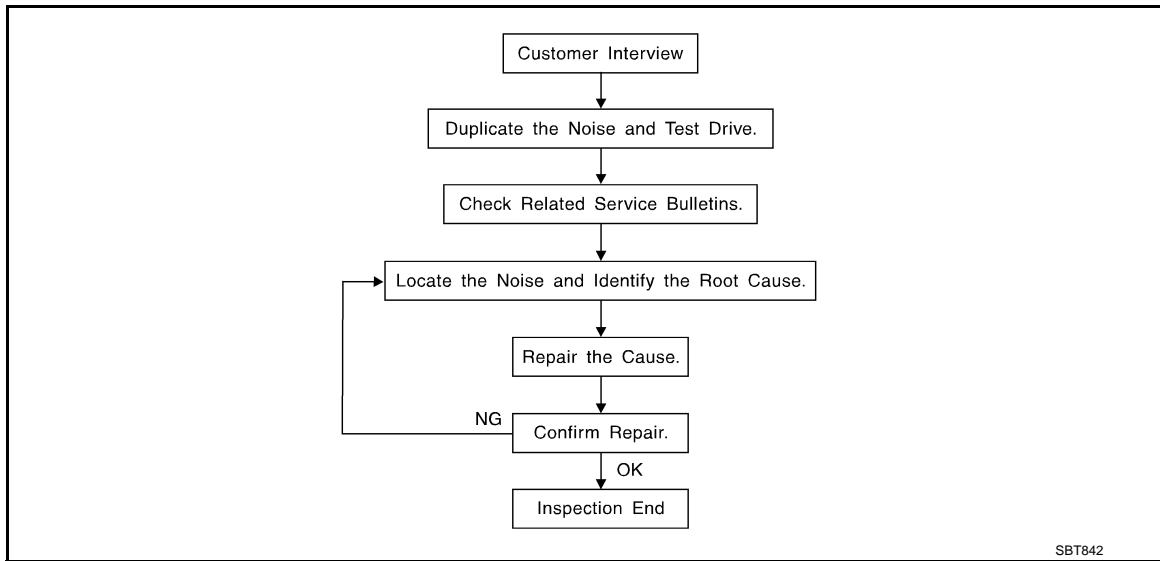

### CUSTOMER INTERVIEW

Interview the customer if possible, to determine the conditions that exist when the noise occurs. Use the Diagnostic Worksheet during the interview to document the facts and conditions when the noise occurs and any of customer's comments; refer to [MIR-39, "Diagnostic Worksheet"](#). This information is necessary to duplicate the conditions that exist when the noise occurs.

- The customer may not be able to provide a detailed description or the location of the noise. Attempt to obtain all the facts and conditions that exist when the noise occurs (or does not occur).
- If there is more than one noise in the vehicle, perform a diagnosis and repair the noise that the customer is concerned about. This can be accomplished by performing a cruise test on the vehicle with the customer.
- After identifying the type of noise, isolate the noise in terms of its characteristics. The noise characteristics are provided so the customer, service adviser and technician are all speaking the same language when defining the noise.
- Squeak – (Like tennis shoes on a clean floor)  
Squeak characteristics include the light contact/fast movement/brought on by road conditions/hard surfaces = higher pitch noise/softer surfaces = lower pitch noises/edge to surface = chirping
- Creak – (Like walking on an old wooden floor)  
Creak characteristics include firm contact/slow movement/twisting with a rotational movement/pitch dependent on materials/often brought on by activity.
- Rattle – (Like shaking a baby rattle)  
Rattle characteristics include the fast repeated contact/vibration or similar movement/loose parts/missing clip or fastener/incorrect clearance.
- Knock – (Like a knock on a door)  
Knock characteristics include hollow sounding/sometimes repeating/often brought on by driver action.
- Tick – (Like a clock second hand)  
Tick characteristics include gentle contacting of light materials/loose components/can be caused by driver action or road conditions.
- Thump – (Heavy, muffled knock noise)  
Thump characteristics include softer knock/dead sound often brought on by activity.
- Buzz – (Like a bumblebee)  
Buzz characteristics include high frequency rattle/firm contact.
- Often the degree of acceptable noise level will vary depending up on the person. A noise that a technician may judge as acceptable may be very irritating to the customer.
- Weather conditions, especially humidity and temperature, may have a great effect on noise level.

### DUPLICATE THE NOISE AND TEST DRIVE

If possible, drive the vehicle with the customer until the noise is duplicated. Note any additional information on the Diagnostic Worksheet regarding the conditions or location of the noise. This information can be used to duplicate the same conditions when the repair is reconfirmed.

# SQUEAK AND RATTLE TROUBLE DIAGNOSES

[WITH ADP]

## < SYMPTOM DIAGNOSIS >

If the noise can be duplicated easily during the test drive, to help identify the source of the noise, try to duplicate the noise with the vehicle stopped by doing one or all of the following:

- 1) Close a door.
  - 2) Tap or push/pull around the area where the noise appears to be coming from.
  - 3) Rev the engine.
  - 4) Use a floor jack to recreate vehicle "twist".
  - 5) At idle, apply engine load (electrical load, half-clutch on M/T models, drive position on A/T models).
  - 6) Raise the vehicle on a hoist and hit a tire with a rubber hammer.
- Drive the vehicle and attempt to duplicate the conditions the customer states exist when the noise occurs.
  - If it is difficult to duplicate the noise, drive the vehicle slowly on an undulating or rough road to stress the vehicle body.

## CHECK RELATED SERVICE BULLETINS

After verifying the customer concern or symptom, check ASIST for Technical Service Bulletins (TSBs) related to that concern or symptom.

If a TSB relates to the symptom, follow the procedure to repair the noise.

## LOCATE THE NOISE AND IDENTIFY THE ROOT CAUSE

1. Narrow down the noise to a general area. To help pinpoint the source of the noise, use a listening tool (Chassis ear: J-39570, Engine ear and mechanics stethoscope).
2. Narrow down the noise to a more specific area and identify the cause of the noise by:
  - Removing the components in the area that is are suspected to be the cause of the noise.  
Do not use too much force when removing clips and fasteners, otherwise clips and fastener can be broken or lost during the repair, resulting in the creation of new noise.
  - Tapping or pushing/pulling the component that is are suspected to be the cause of the noise.  
Do not tap or push/pull the component with excessive force, otherwise the noise will be eliminated only temporarily.
  - Feeling for a vibration by hand by touching the component(s) that is are suspected to be the cause of the noise.
  - Placing a piece of paper between components that are suspected to be the cause of the noise.
  - Looking for loose components and contact marks.  
Refer to [MIR-37. "Inspection Procedure"](#).

## REPAIR THE CAUSE

- If the cause is a loose component, tighten the component securely.
- If the cause is insufficient clearance between components:
  - Separate components by repositioning or loosening and retightening the component, if possible.
  - Insulate components with a suitable insulator such as urethane pads, foam blocks, felt cloth tape or urethane tape. A Nissan Squeak and Rattle Kit (J-43980) is available through the authorized Nissan Parts Department.

### **CAUTION:**

**Never use excessive force as many components are constructed of plastic and may be damaged.**

### **NOTE:**

Always check with the Parts Department for the latest parts information.

The following materials are contained in the Nissan Squeak and Rattle Kit (J-43980). Each item can be ordered separately as needed.

URETHANE PADS [1.5 mm (0.059 in) thick]

Insulates connectors, harness, etc.

76268-9E005: 100 × 135 mm (3.94 × 5.31 in)/76884-71L01: 60 × 85 mm (2.36 × 3.35 in)/76884-71L02: 15 × 25 mm (0.59 × 0.98 in)

INSULATOR (Foam blocks)

Insulates components from contact. Can be used to fill space behind a panel.

73982-9E000: 45 mm (1.77 in) thick, 50 × 50 mm (1.97 × 1.97 in)/73982-

50Y00: 10 mm (0.39 in) thick, 50 × 50 mm (1.97 × 1.97 in)

INSULATOR (Light foam block)

80845-71L00: 30 mm (1.18 in) thick, 30 × 50 mm (1.18 × 1.97in)

FELT CLOTHTAPE

Used to insulate where movement does not occur. Ideal for instrument panel applications.

68370-4B000: 15 × 25 mm (0.59 × 0.98 in) pad/68239-13E00: 5 mm (0.20 in) wide tape roll

The following materials, not found in the kit, can also be used to repair squeaks and rattles.

UHMW (TEFLON) TAPE

# SQUEAK AND RATTLE TROUBLE DIAGNOSES

[WITH ADP]

## < SYMPTOM DIAGNOSIS >

Insulates where slight movement is present. Ideal for instrument panel applications.

### SILICONE GREASE

Used in place of UHMW tape that is be visible or does not fit. Will only last a few months.

### SILICONE SPRAY

Used when grease cannot be applied.

### DUCT TAPE

Used to eliminate movement.

## CONFIRM THE REPAIR

Confirm that the cause of a noise is repaired by test driving the vehicle. Operate the vehicle under the same conditions as when the noise originally occurred. Refer to the notes on the Diagnostic Worksheet.

## Inspection Procedure

INFOID:000000007540677

Refer to Table of Contents for specific component removal and installation information.

## INSTRUMENT PANEL

Most incidents are caused by contact and movement between:

1. The cluster lid A and instrument panel
2. Acrylic lens and combination meter housing
3. Instrument panel to front pillar garnish
4. Instrument panel to windshield
5. Instrument panel mounting pins
6. Wiring harnesses behind the combination meter
7. A/C defroster duct and duct joint

These incidents can usually be located by tapping or moving the components to duplicate the noise or by pressing on the components while driving to stop the noise. Most of these incidents can be repaired by applying felt cloth tape or silicon spray (in hard to reach areas). Urethane pads can be used to insulate wiring harness.

### **CAUTION:**

**Never use silicone spray to isolate a squeak or rattle. If the area is saturated with silicone, the recheck of repair becomes impossible.**

## CENTER CONSOLE

Components to pay attention to include:

1. Shifter assembly cover to finisher
2. A/C control unit and cluster lid C
3. Wiring harnesses behind audio and A/C control unit

The instrument panel repair and isolation procedures also apply to the center console.

## DOORS

Pay attention to the following:

1. Finisher and inner panel making a slapping noise
2. Inside handle escutcheon to door finisher
3. Wiring harnesses tapping
4. Door striker out of alignment causing a popping noise on starts and stops

Tapping or moving the components or pressing on them while driving to duplicate the conditions can isolate many of these incidents. The areas can usually be insulated with felt cloth tape or insulator foam blocks from the Nissan Squeak and Rattle Kit (J-43980) to repair the noise.

## TRUNK

Trunk noises are often caused by a loose jack or loose items put into the trunk by the customer.

In addition look for the following:

1. Trunk lid dumpers out of adjustment
2. Trunk lid striker out of adjustment
3. The trunk lid torsion bars knocking together
4. A loose license plate or bracket

A

B

C

D

E

F

G

H

I

J

K

MIR

M

N

O

P

# SQUEAK AND RATTLE TROUBLE DIAGNOSES

[WITH ADP]

## < SYMPTOM DIAGNOSIS >

Most of these incidents can be repaired by adjusting, securing or insulating the item(s) or component(s) causing the noise.

### SUNROOF/HEADLINING

Noises in the sunroof/headlining area can often be traced to one of the following:

1. Sunroof lid, rail, linkage or seals making a rattle or light knocking noise
2. Sunvisor shaft shaking in the holder
3. Front or rear windshield touching headlining and squeaking

Again, pressing on the components to stop the noise while duplicating the conditions can isolate most of these incidents. Repairs usually consist of insulating with felt cloth tape.

### SEATS

When isolating seat noise it's important to note the position the seats in and the load placed on the seat when the noise occurs. These conditions should be duplicated when verifying and isolating the cause of the noise.

Cause of seat noise include:

1. Headrest rods and holder
2. A squeak between the seat pad cushion and frame
3. The rear seatback lock and bracket

These noises can be isolated by moving or pressing on the suspected components while duplicating the conditions under which the noise occurs. Most of these incidents can be repaired by repositioning the component or applying urethane tape to the contact area.

### UNDERHOOD

Some interior noise may be caused by components under the hood or on the engine wall. The noise is then transmitted into the passenger compartment.

Causes of transmitted underhood noise include:

1. Any component mounted to the engine wall
2. Components that pass through the engine wall
3. Engine wall mounts and connectors
4. Loose radiator mounting pins
5. Hood bumpers out of adjustment
6. Hood striker out of adjustment

These noises can be difficult to isolate since they cannot be reached from the interior of the vehicle. The best method is to secure, move or insulate one component at a time and test drive the vehicle. Also, engine RPM or load can be changed to isolate the noise. Repairs can usually be made by moving, adjusting, securing, or insulating the component causing the noise.

# SQUEAK AND RATTLE TROUBLE DIAGNOSES

< SYMPTOM DIAGNOSIS >

[WITH ADP]

## Diagnostic Worksheet

INFOID:000000007540678



### SQUEAK & RATTLE DIAGNOSTIC WORKSHEET

Dear Nissan Customer:

We are concerned about your satisfaction with your Nissan vehicle. Repairing a squeak or rattle sometimes can be very difficult. To help us fix your Nissan right the first time, please take a moment to note the area of the vehicle where the squeak or rattle occurs and under what conditions. You may be asked to take a test drive with a service advisor or technician to ensure we confirm the noise you are hearing.

#### I. WHERE DOES THE NOISE COME FROM? (circle the area of the vehicle)

The illustrations are for reference only, and may not reflect the actual configuration of your vehicle.

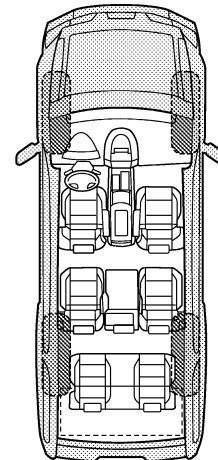
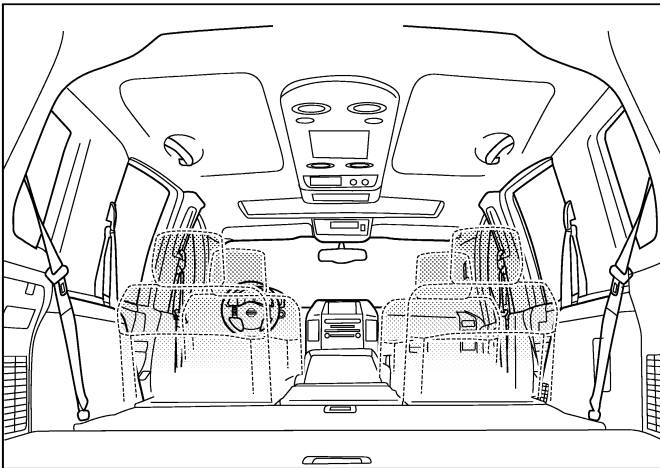
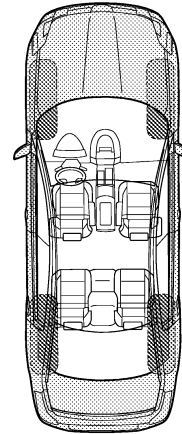
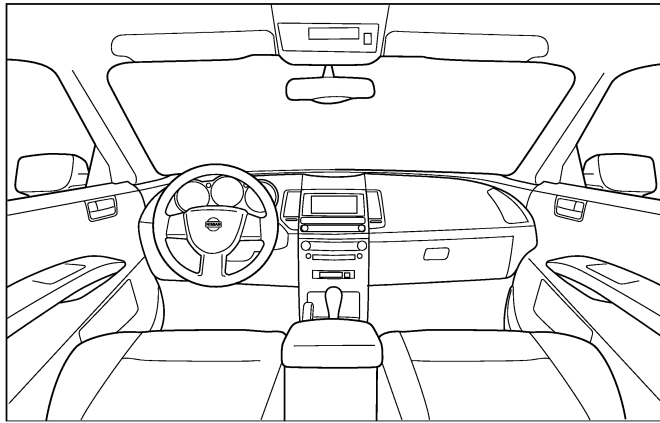

Continue to page 2 of the worksheet and briefly describe the location of the noise or rattle. In addition, please indicate the conditions which are present when the noise occurs.

PIIB8740E

A  
B  
C  
D  
E  
F  
G  
H  
I  
J  
K  
M  
N  
O  
P

MIR

# SQUEAK AND RATTLE TROUBLE DIAGNOSES

< SYMPTOM DIAGNOSIS >

[WITH ADP]

## SQUEAK & RATTLE DIAGNOSTIC WORKSHEET - page 2

Briefly describe the location where the noise occurs:

---

---

### II. WHEN DOES IT OCCUR? (please check the boxes that apply)

- |   |  |
|---|--|
| <input type="checkbox"/> anytime                      | <input type="checkbox"/> after sitting out in the rain |
| <input type="checkbox"/> 1st time in the morning      | <input type="checkbox"/> when it is raining or wet     |
| <input type="checkbox"/> only when it is cold outside | <input type="checkbox"/> dry or dusty conditions       |
| <input type="checkbox"/> only when it is hot outside  | <input type="checkbox"/> other:                        |

### III. WHEN DRIVING:

- through driveways
- over rough roads
- over speed bumps
- only about \_\_\_\_ mph
- on acceleration
- coming to a stop
- on turns: left, right or either (circle)
- with passengers or cargo
- other: \_\_\_\_\_
- after driving \_\_\_\_ miles or \_\_\_\_ minutes

### IV. WHAT TYPE OF NOISE

- squeak (like tennis shoes on a clean floor)
- creak (like walking on an old wooden floor)
- rattle (like shaking a baby rattle)
- knock (like a knock at the door)
- tick (like a clock second hand)
- thump (heavy, muffled knock noise)
- buzz (like a bumble bee)

## TO BE COMPLETED BY DEALERSHIP PERSONNEL

### Test Drive Notes:

---

---

---

	YES	NO	Initials of person performing
Vehicle test driven with customer	<input type="checkbox"/>	<input type="checkbox"/>	_____
- Noise verified on test drive	<input type="checkbox"/>	<input type="checkbox"/>	_____
- Noise source located and repaired	<input type="checkbox"/>	<input type="checkbox"/>	_____
- Follow up test drive performed to confirm repair	<input type="checkbox"/>	<input type="checkbox"/>	_____

VIN: \_\_\_\_\_ Customer Name: \_\_\_\_\_

W.O.# \_\_\_\_\_ Date: \_\_\_\_\_

This form must be attached to Work Order

PIIB8742E



PRECAUTION

PRECAUTIONS  
FOR USA AND CANADA

FOR USA AND CANADA : Precaution for Supplemental Restraint System (SRS) "AIR BAG" and "SEAT BELT PRE-TENSIONER"

INFOID:000000007540679

The Supplemental Restraint System such as "AIR BAG" and "SEAT BELT PRE-TENSIONER", used along with a front seat belt, helps to reduce the risk or severity of injury to the driver and front passenger for certain types of collision. This system includes seat belt switch inputs and dual stage front air bag modules. The SRS system uses the seat belt switches to determine the front air bag deployment, and may only deploy one front air bag, depending on the severity of a collision and whether the front occupants are belted or unbelted. Information necessary to service the system safely is included in the "SRS AIR BAG" and "SEAT BELT" of this Service Manual.

**WARNING:**

Always observe the following items for preventing accidental activation.

- To avoid rendering the SRS inoperative, which could increase the risk of personal injury or death in the event of a collision that would result in air bag inflation, all maintenance must be performed by an authorized NISSAN/INFINITI dealer.
- Improper maintenance, including incorrect removal and installation of the SRS, can lead to personal injury caused by unintentional activation of the system. For removal of Spiral Cable and Air Bag Module, see "SRS AIR BAG".
- Never use electrical test equipment on any circuit related to the SRS unless instructed to in this Service Manual. SRS wiring harnesses can be identified by yellow and/or orange harnesses or harness connectors.

PRECAUTIONS WHEN USING POWER TOOLS (AIR OR ELECTRIC) AND HAMMERS

**WARNING:**

Always observe the following items for preventing accidental activation.

- When working near the Air Bag Diagnosis Sensor Unit or other Air Bag System sensors with the ignition ON or engine running, never use air or electric power tools or strike near the sensor(s) with a hammer. Heavy vibration could activate the sensor(s) and deploy the air bag(s), possibly causing serious injury.
- When using air or electric power tools or hammers, always switch the ignition OFF, disconnect the battery, and wait at least 3 minutes before performing any service.

FOR USA AND CANADA : Precaution for Procedure without Cowl Top Cover

INFOID:000000007540680

When performing the procedure after removing cowl top cover, cover the lower end of windshield with urethane, etc to prevent damage to windshield.

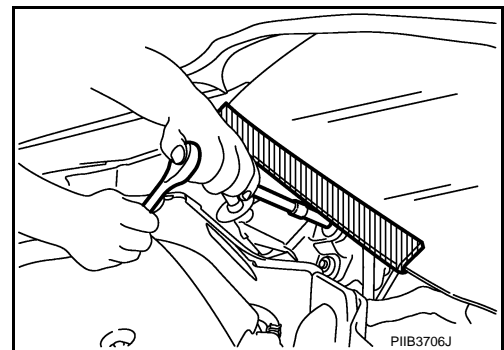

FOR USA AND CANADA : Precaution for Work

INFOID:000000007540681

- After removing and installing the opening/closing parts, be sure to carry out fitting adjustments to check their operation.
- Check the lubrication level, damage, and wear of each part. If necessary, grease or replace it.

FOR MEXICO

FOR MEXICO : Precaution for Supplemental Restraint System (SRS) "AIR BAG" and

A  
B  
C  
D  
E  
F  
G  
H  
I  
J  
K  
M  
N  
O  
P

MIR

# PRECAUTIONS

< PRECAUTION >

[WITH ADP]

## "SEAT BELT PRE-TENSIONER"

INFOID:000000007540682

The Supplemental Restraint System such as "AIR BAG" and "SEAT BELT PRE-TENSIONER", used along with a front seat belt, helps to reduce the risk or severity of injury to the driver and front passenger for certain types of collision. Information necessary to service the system safely is included in the "SRS AIR BAG" and "SEAT BELT" of this Service Manual.

### **WARNING:**

Always observe the following items for preventing accidental activation.

- To avoid rendering the SRS inoperative, which could increase the risk of personal injury or death in the event of a collision that would result in air bag inflation, all maintenance must be performed by an authorized NISSAN/INFINITI dealer.
- Improper maintenance, including incorrect removal and installation of the SRS, can lead to personal injury caused by unintentional activation of the system. For removal of Spiral Cable and Air Bag Module, see "SRS AIR BAG".
- Never use electrical test equipment on any circuit related to the SRS unless instructed to in this Service Manual. SRS wiring harnesses can be identified by yellow and/or orange harnesses or harness connectors.

## PRECAUTIONS WHEN USING POWER TOOLS (AIR OR ELECTRIC) AND HAMMERS

### **WARNING:**

Always observe the following items for preventing accidental activation.

- When working near the Air Bag Diagnosis Sensor Unit or other Air Bag System sensors with the ignition ON or engine running, never use air or electric power tools or strike near the sensor(s) with a hammer. Heavy vibration could activate the sensor(s) and deploy the air bag(s), possibly causing serious injury.
- When using air or electric power tools or hammers, always switch the ignition OFF, disconnect the battery, and wait at least 3 minutes before performing any service.

## FOR MEXICO : Precaution for Procedure without Cowl Top Cover

INFOID:000000007540683

When performing the procedure after removing cowl top cover, cover the lower end of windshield with urethane, etc to prevent damage to windshield.

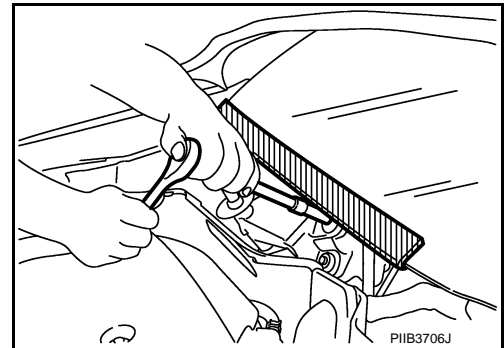

## FOR MEXICO : Precaution for Work

INFOID:000000007540684

- After removing and installing the opening/closing parts, be sure to carry out fitting adjustments to check their operation.
- Check the lubrication level, damage, and wear of each part. If necessary, grease or replace it.

# PREPARATION

< PREPARATION >

[WITH ADP]

## PREPARATION

### PREPARATION

#### Special Service Tools

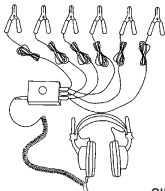
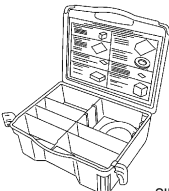

INFOID:000000007540685

The actual shapes of Kent-Moore tools may differ from those of special service tools illustrated here.

Tool number (Kent-Moore No.) Tool name	Description
<p>(J-39570) Chassis ear</p>  <p>SIIA0993E</p>	<p>Locates the noise</p>
<p>(J-43980) NISSAN Squeak and Rattle Kit</p>  <p>SIIA0994E</p>	<p>Repairs the cause of noise</p>

#### Commercial Service Tools

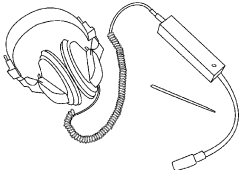
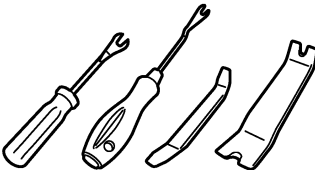
INFOID:000000007540686

Tool name	Description
<p>Engine ear</p>  <p>SIIA0995E</p>	<p>Locates the noise</p>
<p>Remover tool</p>  <p>JMKIA3050ZZ</p>	<p>Removes the clips, pawls, and metal clips</p>
<p>Power tool</p>  <p>PIIB1407E</p>	

# INSIDE MIRROR

< REMOVAL AND INSTALLATION >

[WITH ADP]

## REMOVAL AND INSTALLATION

### INSIDE MIRROR

Exploded View

INFOID:000000007540687

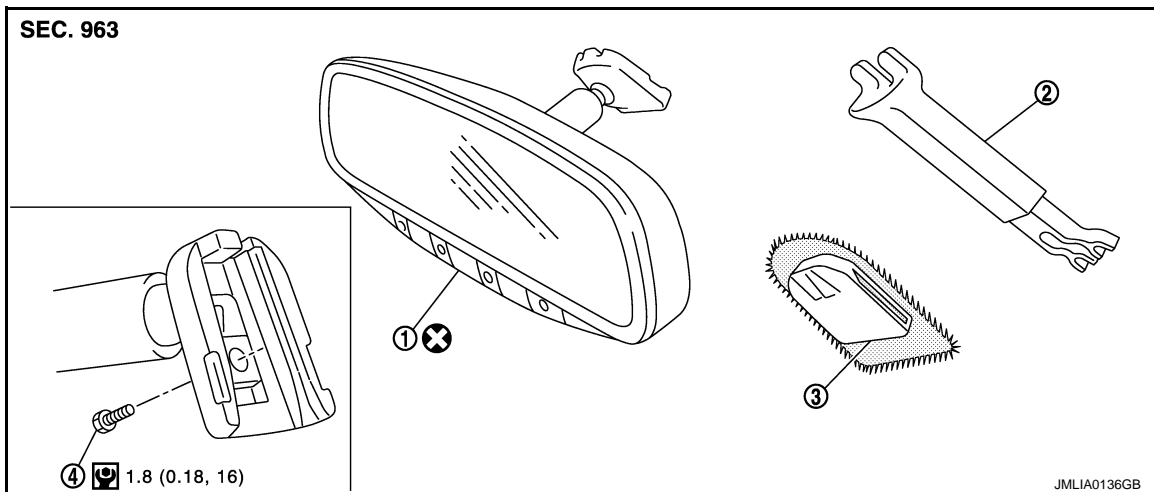

1. Inside mirror

2. Inside mirror cover

3. Mirror base

4. TORX bolt

Refer to [GI-4. "Components"](#) for symbols in the figure.

### Removal and Installation

INFOID:000000007540688

#### **CAUTION:**

**Never reuse the inside mirror disassembled from mirror base.**

#### REMOVAL

1. Remove the inside mirror cover.
2. Remove TORX bolt.
3. Slide the inside mirror upward to remove.

#### INSTALLATION

Install in the reverse order of removal.

#### **CAUTION:**

**When inserting the inside mirror into the mirror base, be sure to push the pawl until it get connected to the mirror base.**

# OUTSIDE MIRROR

< REMOVAL AND INSTALLATION >

[WITH ADP]

## OUTSIDE MIRROR DOOR MIRROR ASSEMBLY

### DOOR MIRROR ASSEMBLY : Exploded View

INFOID:000000007540689

#### REMOVAL

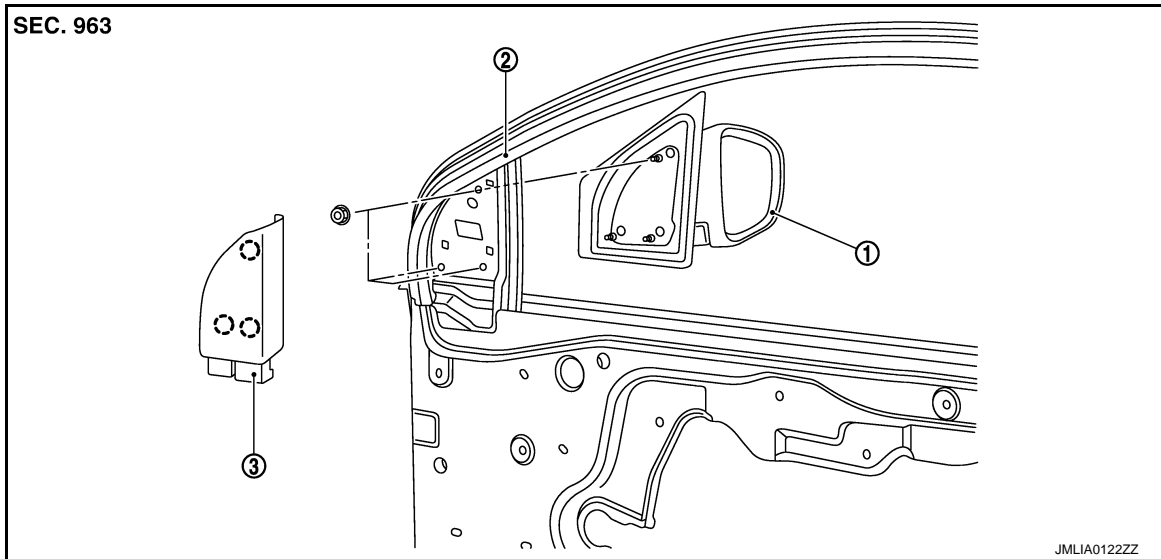

1. Door mirror assembly

2. Front door assembly

3. Door mirror corner cover

○ : Clip

#### DISASSEMBLY

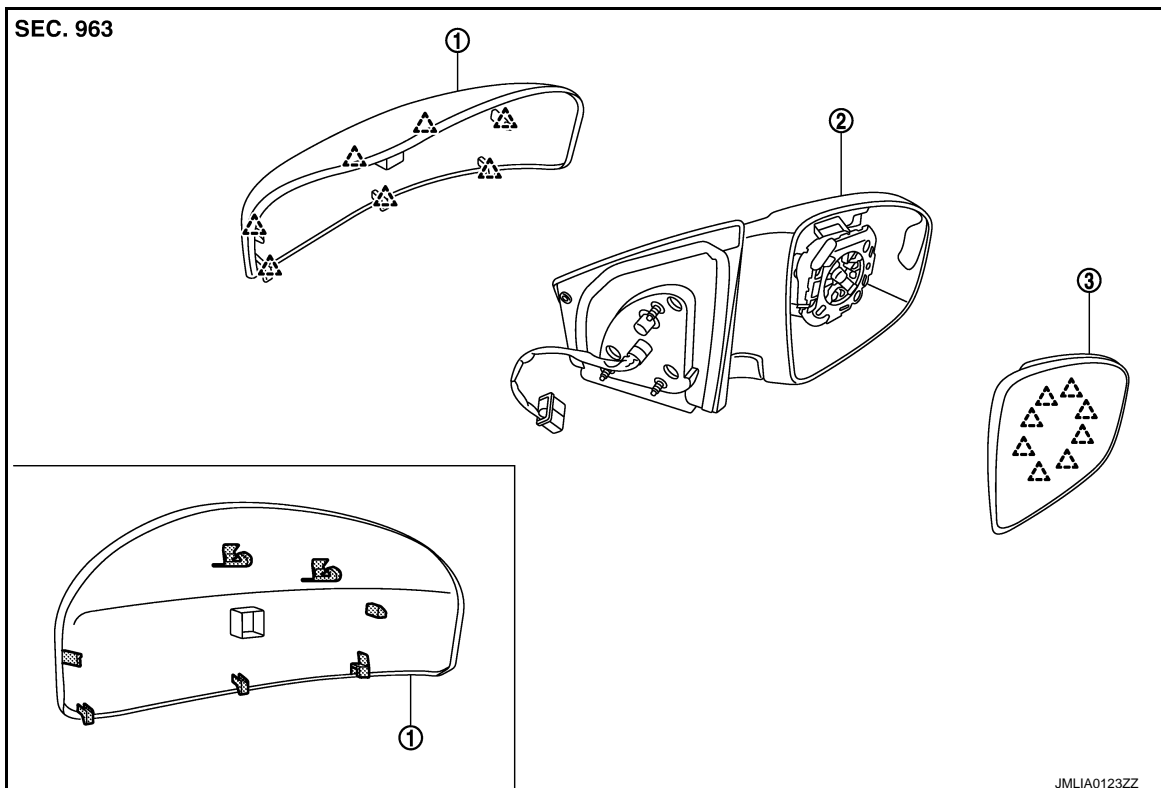

A  
B  
C  
D  
E  
F  
G  
H  
I  
J  
K  
L  
M  
N  
O  
P

MIR

# OUTSIDE MIRROR

< REMOVAL AND INSTALLATION >

[WITH ADP]

1. Door mirror cover
2. Door mirror assembly
3. Glass mirror

 : Pawl

## DOOR MIRROR ASSEMBLY : Removal and Installation

INFOID:000000007540690

### CAUTION:

**Never damage the mirror bodies.**

### REMOVAL

1. Remove the front door finisher. Refer to [INT-12, "FRONT DOOR FINISHER : Removal and Installation"](#).
2. Remove the door mirror corner cover.
3. Disconnect the door mirror harness connector.
4. Remove the door mirror mounting nuts, and remove the door mirror assembly.

### INSTALLATION

Install in the reverse order of removal.

## GLASS MIRROR

### GLASS MIRROR : Exploded View

INFOID:000000007540691

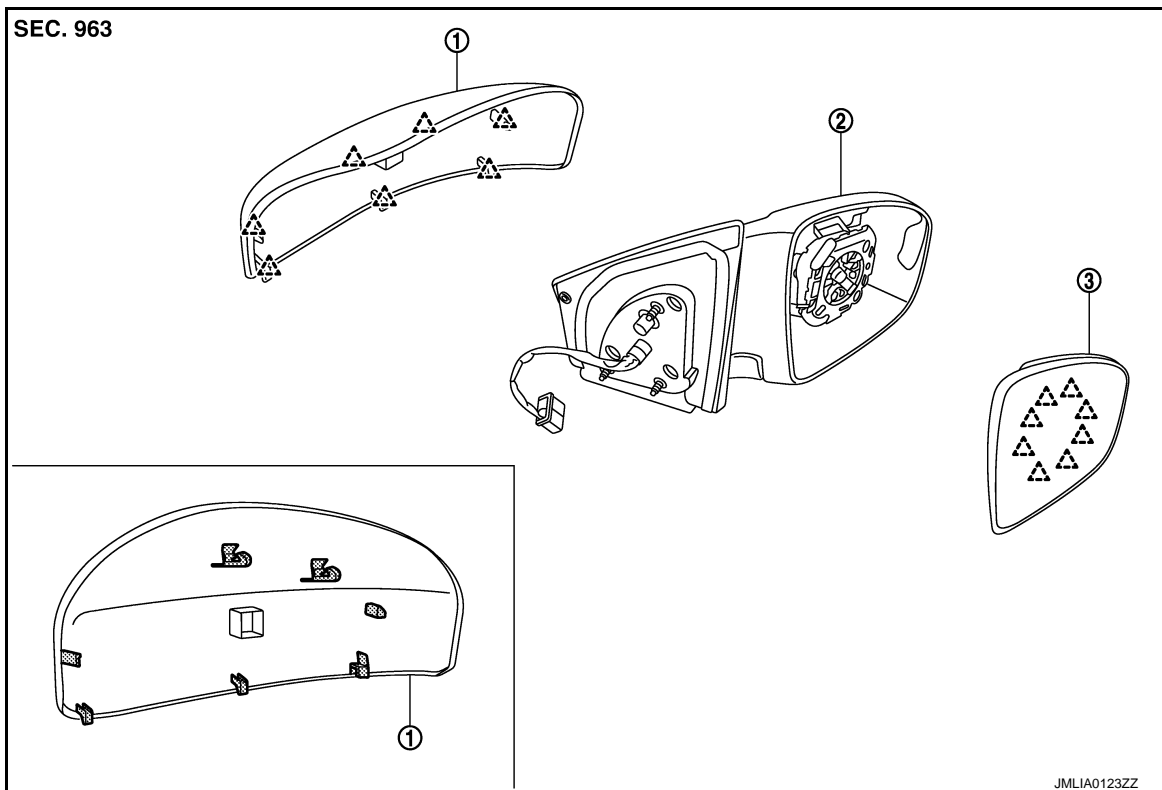

1. Door mirror cover
2. Door mirror assembly
3. Glass mirror

 : Pawl

## GLASS MIRROR : Disassembly and Assembly

INFOID:000000007540692

### CAUTION:

**Never damage the mirror bodies.**

### DISASSEMBLY

# OUTSIDE MIRROR

## < REMOVAL AND INSTALLATION >

[WITH ADP]

1. Place the glass mirror upward.
2. Put a strip of protective tape (A) on the housing.
3. Insert flat-bladed screwdriver (B) into the recess at lower side between glass mirror (1) and actuator (2), and push up pawls to remove glass mirror lower side.

**NOTE:**

Insert a small slotted screwdriver into recess, and push up while rotating (twist) to make work easier.

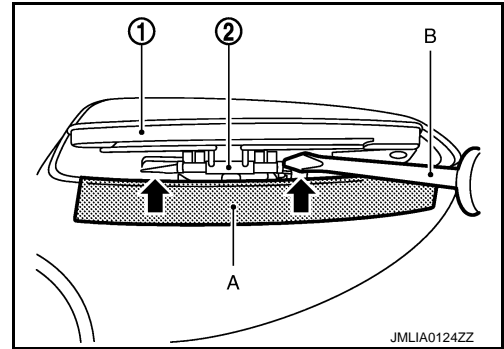

4. Insert flat-bladed screwdriver at RH/LH side between glass mirror and actuator, and push up pawls to remove glass mirror RH/LH side.

**NOTE:**

Insert flat-bladed screwdriver into recesses, and push up while rotating (twist) to make work easier.

5. Remove two terminals of mirror heater attachment. (With heater mirror model)
6. Pull glass mirror as shown in the figure in order to disengage both upper pawls, and then remove glass mirror.

1. Glass mirror
2. Actuator

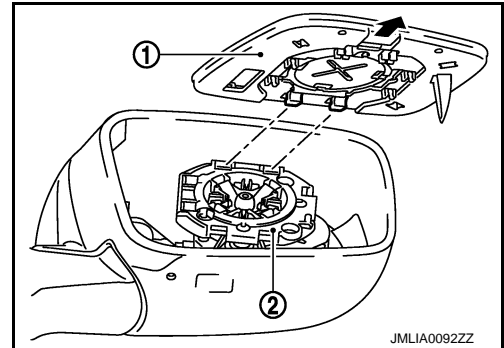

## ASSEMBLY

Install in the reverse order of removal.

**CAUTION:**

After installation, visually check that pawls are securely engaged.

## DOOR MIRROR COVER

A  
B  
C  
D  
E  
F  
G  
H  
I  
J  
K  
M  
N  
O  
P

MIR

# OUTSIDE MIRROR

< REMOVAL AND INSTALLATION >

[WITH ADP]

## DOOR MIRROR COVER : Exploded View

INFOID:000000007540693

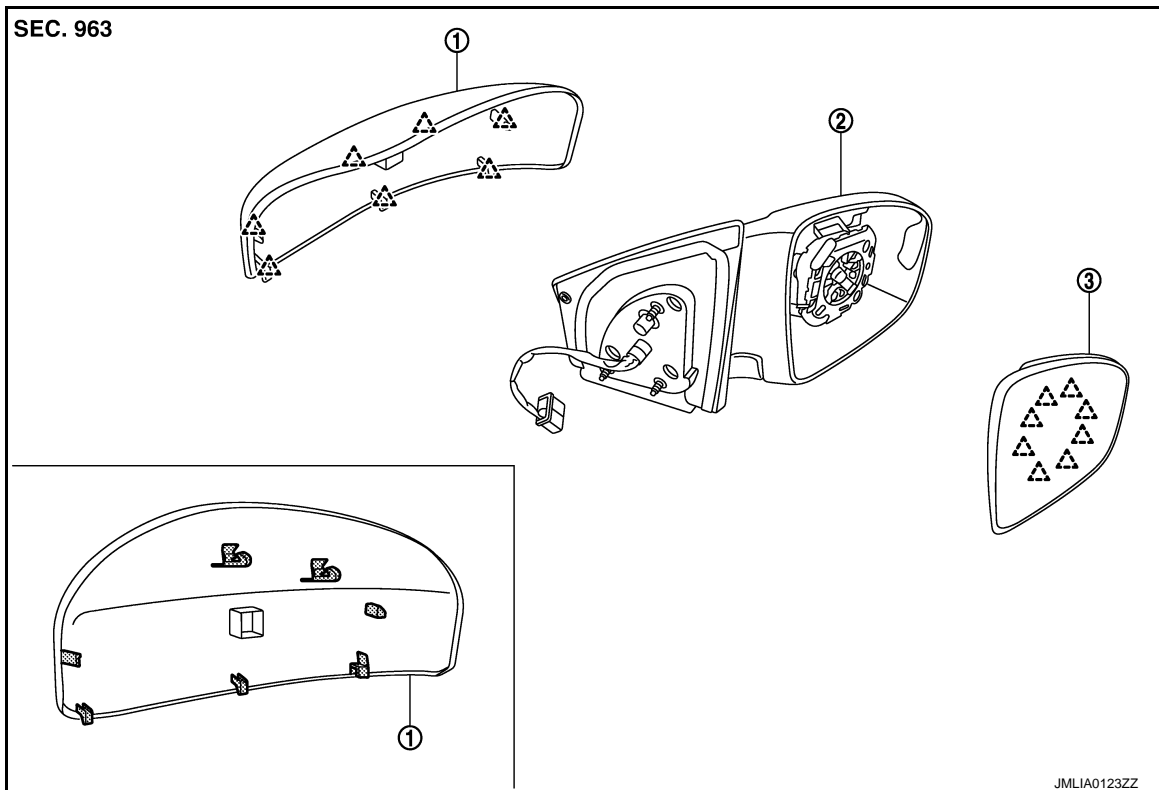

1. Door mirror cover

2. Door mirror assembly

3. Glass mirror

 : Pawl

## DOOR MIRROR COVER : Disassembly and Assembly

INFOID:000000007540694

### CAUTION:

**Never damage the mirror bodies.**

### DISASSEMBLY

1. Remove the glass mirror. Refer to [MIR-46. "GLASS MIRROR : Disassembly and Assembly"](#).
2. Remove the pawls, and disassemble the door mirror cover from the mirror assembly.

### ASSEMBLY

Install in the reverse order of removal.

### NOTE:

After installation, visually check that pawls are securely engaged.



# DOOR MIRROR REMOTE CONTROL SWITCH

< REMOVAL AND INSTALLATION >

[WITH ADP]

## DOOR MIRROR REMOTE CONTROL SWITCH

### Exploded View

INFOID:000000007540695

Refer to [INT-12. "FRONT DOOR FINISHER : Exploded View"](#)

### Removal and Installation

INFOID:000000007540696

#### REMOVAL

1. Remove the power window main switch finisher (2). Refer to [PWC-92. "Removal and Installation"](#)
2. Remove door mirror remote control switch (1) from power window main switch finisher (2) using remover tool (A).

 : Pawl

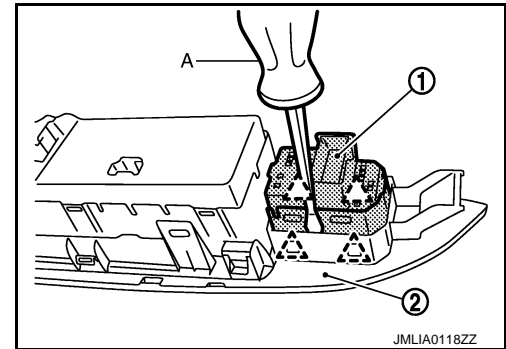

#### INSTALLATION

Install in the reverse order of removal.

A  
B  
C  
D  
E  
F  
G  
H  
I  
J  
K

MIR

M  
N  
O  
P

# DOOR MIRROR SYSTEM

< SYSTEM DESCRIPTION >

[WITHOUT ADP]

## SYSTEM DESCRIPTION

### DOOR MIRROR SYSTEM

#### Component Description

INFOID:000000007540697

Component	Function
Door mirror remote control switch	It supplies power to mirror motor through mirror switch and changeover switch.
Door mirror	It makes mirror face operate from side to side and up and down with the mirror control switch operation.

# INSIDE MIRROR SYSTEM

< SYSTEM DESCRIPTION >

[WITHOUT ADP]

## INSIDE MIRROR SYSTEM

### System Description

INFOID:000000007540698

The sensor built in inside mirror detects the headlight of the vehicle behind and automatically changes the light transmission to decrease the brightness.

### Component Description

INFOID:000000007540699

Component	Function
Auto anti-dazzling inside mirror	It automatically changes the light transmittance according to the brightness of the light from the headlight of the vehicle behind.

A  
B  
C  
D  
E  
F  
G  
H  
I  
J  
K  
M  
N  
O  
P

MIR

# DOOR MIRROR

< DTC/CIRCUIT DIAGNOSIS >

[WITHOUT ADP]

## DTC/CIRCUIT DIAGNOSIS

### DOOR MIRROR

#### Wiring Diagram - DOOR MIRROR SYSTEM (WITHOUT AUTOMATIC DRIVE POSITIONER) -

INFOID:000000007540700

For connector terminal arrangements, harness layouts, and alphabets in a ◊ (option abbreviation; if not described in wiring diagram), refer to [GI-12, "Connector Information"](#).

#### DOOR MIRROR (WITHOUT AUTOMATIC DRIVE POSITIONER)

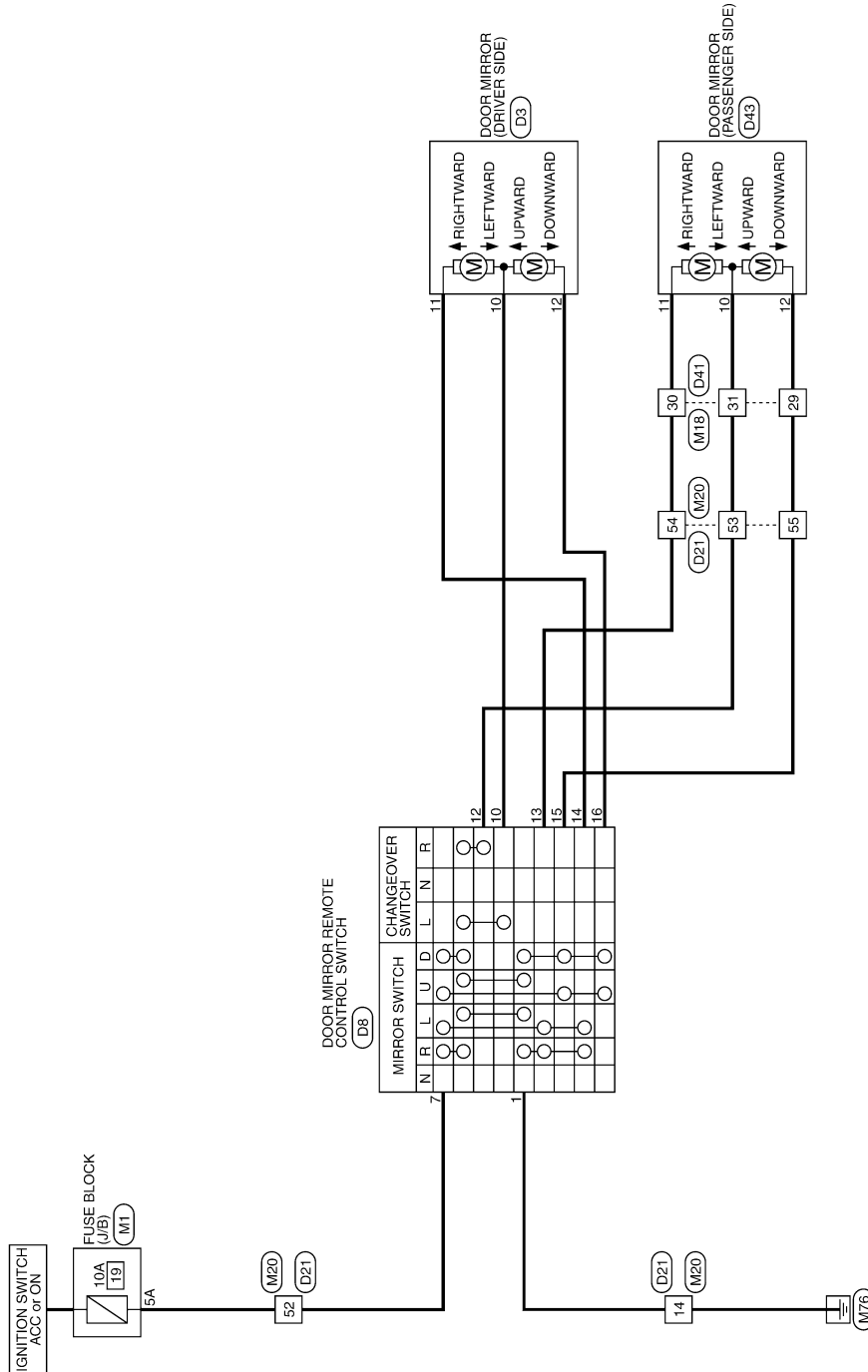

2008/09/23

JCLWM2740GB

# AUTO ANTI-DAZZLING INSIDE MIRROR SYSTEM

< DTC/CIRCUIT DIAGNOSIS >

[WITHOUT ADP]

## AUTO ANTI-DAZZLING INSIDE MIRROR SYSTEM

### Wiring Diagram - INSIDE MIRROR SYSTEM -

INFOID:000000007824628

For connector terminal arrangements, harness layouts, and alphabets in a  (option abbreviation; if not described in wiring diagram), refer to [GI-12, "Connector Information"](#).

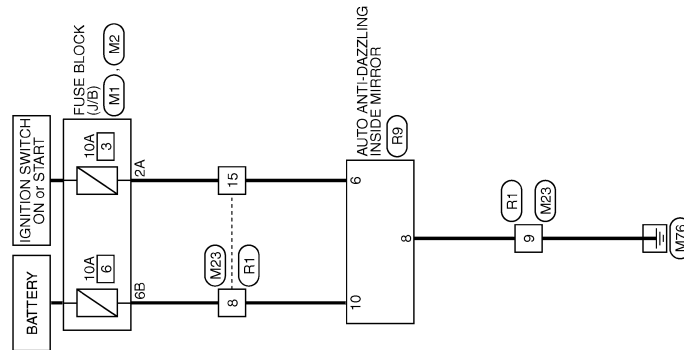

INSIDE MIRROR

2010/09/06

JCLWM6099GB

A  
B  
C  
D  
E  
F  
G  
H  
I  
J  
K  
L  
M  
N  
O  
P

MIR

## SYMPTOM DIAGNOSIS

### SQUEAK AND RATTLE TROUBLE DIAGNOSES

#### Work Flow

INFOID:000000007540702

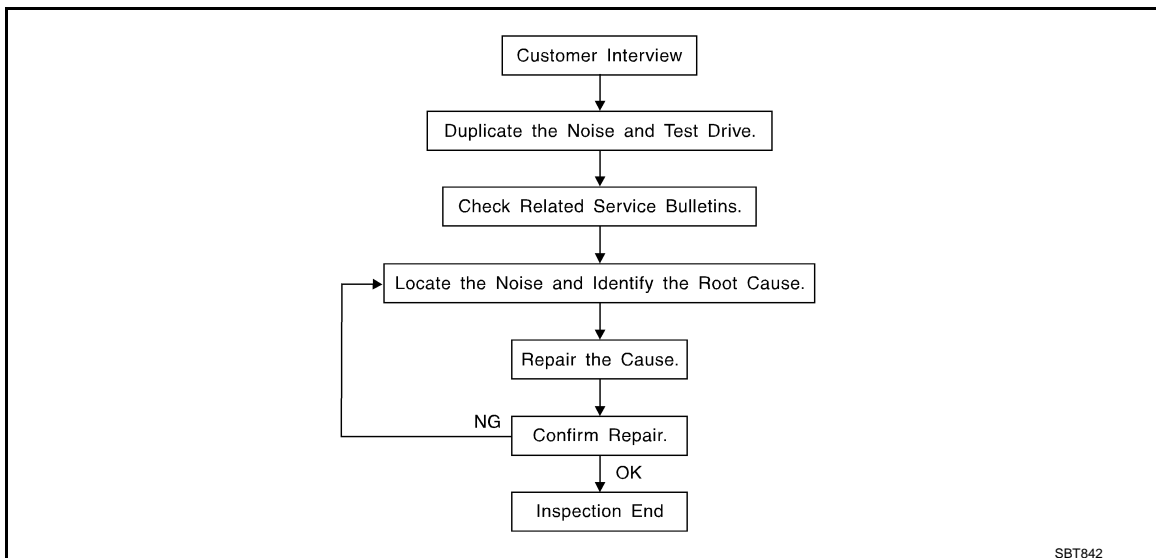

SBT842

#### CUSTOMER INTERVIEW

Interview the customer if possible, to determine the conditions that exist when the noise occurs. Use the Diagnostic Worksheet during the interview to document the facts and conditions when the noise occurs and any of customer's comments; refer to [MIR-58. "Diagnostic Worksheet"](#). This information is necessary to duplicate the conditions that exist when the noise occurs.

- The customer may not be able to provide a detailed description or the location of the noise. Attempt to obtain all the facts and conditions that exist when the noise occurs (or does not occur).
- If there is more than one noise in the vehicle, perform a diagnosis and repair the noise that the customer is concerned about. This can be accomplished by performing a cruise test on the vehicle with the customer.
- After identifying the type of noise, isolate the noise in terms of its characteristics. The noise characteristics are provided so the customer, service adviser and technician are all speaking the same language when defining the noise.
- Squeak – (Like tennis shoes on a clean floor)  
Squeak characteristics include the light contact/fast movement/brought on by road conditions/hard surfaces = higher pitch noise/softer surfaces = lower pitch noises/edge to surface = chirping
- Creak – (Like walking on an old wooden floor)  
Creak characteristics include firm contact/slow movement/twisting with a rotational movement/pitch dependent on materials/often brought on by activity.
- Rattle – (Like shaking a baby rattle)  
Rattle characteristics include the fast repeated contact/vibration or similar movement/loose parts/missing clip or fastener/incorrect clearance.
- Knock – (Like a knock on a door)  
Knock characteristics include hollow sounding/sometimes repeating/often brought on by driver action.
- Tick – (Like a clock second hand)  
Tick characteristics include gentle contacting of light materials/loose components/can be caused by driver action or road conditions.
- Thump – (Heavy, muffled knock noise)  
Thump characteristics include softer knock/dead sound often brought on by activity.
- Buzz – (Like a bumblebee)  
Buzz characteristics include high frequency rattle/firm contact.
- Often the degree of acceptable noise level will vary depending up on the person. A noise that you may judge as acceptable may be very irritating to the customer.
- Weather conditions, especially humidity and temperature, may have a great effect on noise level.

#### DUPLICATE THE NOISE AND TEST DRIVE

# SQUEAK AND RATTLE TROUBLE DIAGNOSES

< SYMPTOM DIAGNOSIS >

[WITHOUT ADP]

If possible, drive the vehicle with the customer until the noise is duplicated. Note any additional information on the Diagnostic Worksheet regarding the conditions or location of the noise. This information can be used to duplicate the same conditions when you confirm the repair.

If the noise can be duplicated easily during the test drive, to help identify the source of the noise, try to duplicate the noise with the vehicle stopped by doing one or all of the following:

- 1) Close a door.
  - 2) Tap or push/pull around the area where the noise appears to be coming from.
  - 3) Rev the engine.
  - 4) Use a floor jack to recreate vehicle "twist".
  - 5) At idle, apply engine load (electrical load, half-clutch on M/T models, drive position on A/T models).
  - 6) Raise the vehicle on a hoist and hit a tire with a rubber hammer.
- Drive the vehicle and attempt to duplicate the conditions the customer states exist when the noise occurs.
  - If it is difficult to duplicate the noise, drive the vehicle slowly on an undulating or rough road to stress the vehicle body.

## CHECK RELATED SERVICE BULLETINS

After verifying the customer concern or symptom, check ASIST for Technical Service Bulletins (TSBs) related to that concern or symptom.

If a TSB relates to the symptom, follow the procedure to repair the noise.

## LOCATE THE NOISE AND IDENTIFY THE ROOT CAUSE

1. Narrow down the noise to a general area. To help pinpoint the source of the noise, use a listening tool (Chassis Ear: J-39570, Engine Ear and mechanics stethoscope).
2. Narrow down the noise to a more specific area and identify the cause of the noise by:
  - Removing the components in the area that you suspect the noise is coming from.  
Do not use too much force when removing clips and fasteners, otherwise clips and fastener can be broken or lost during the repair, resulting in the creation of new noise.
  - Tapping or pushing/pulling the component that you suspect is causing the noise.  
Do not tap or push/pull the component with excessive force, otherwise the noise will be eliminated only temporarily.
  - Feeling for a vibration with your hand by touching the component(s) that you suspect is (are) causing the noise.
  - Placing a piece of paper between components that you suspect are causing the noise.
  - Looking for loose components and contact marks.  
Refer to [MIR-56. "Inspection Procedure"](#).

## REPAIR THE CAUSE

- If the cause is a loose component, tighten the component securely.
- If the cause is insufficient clearance between components:
  - Separate components by repositioning or loosening and retightening the component, if possible.
  - Insulate components with a suitable insulator such as urethane pads, foam blocks, felt cloth tape or urethane tape. A Nissan Squeak and Rattle Kit (J-43980) is available through your authorized Nissan Parts Department.

### CAUTION:

**Do not use excessive force as many components are constructed of plastic and may be damaged.**

### NOTE:

Always check with the Parts Department for the latest parts information.

The following materials are contained in the Nissan Squeak and Rattle Kit (J-43980). Each item can be ordered separately as needed.

URETHANE PADS [1.5 mm (0.059 in) thick]

Insulates connectors, harness, etc.

76268-9E005: 100 × 135 mm (3.94 × 5.31 in)/76884-71L01: 60 × 85 mm (2.36 × 3.35 in)/76884-71L02: 15 × 25 mm (0.59 × 0.98 in)

INSULATOR (Foam blocks)

Insulates components from contact. Can be used to fill space behind a panel.

73982-9E000: 45 mm (1.77 in) thick, 50 × 50 mm (1.97 × 1.97 in)/73982-

50Y00: 10 mm (0.39 in) thick, 50 × 50 mm (1.97 × 1.97 in)

INSULATOR (Light foam block)

80845-71L00: 30 mm (1.18 in) thick, 30 × 50 mm (1.18 × 1.97in)

FELT CLOTHTAPE

Used to insulate where movement does not occur. Ideal for instrument panel applications.

# SQUEAK AND RATTLE TROUBLE DIAGNOSES

< SYMPTOM DIAGNOSIS >

[WITHOUT ADP]

68370-4B000: 15 × 25 mm (0.59 × 0.98 in) pad/68239-13E00: 5 mm (0.20 in) wide tape roll

The following materials, not found in the kit, can also be used to repair squeaks and rattles.

## UHMW (TEFLON) TAPE

Insulates where slight movement is present. Ideal for instrument panel applications.

## SILICONE GREASE

Used in place of UHMW tape that will be visible or not fit. Will only last a few months.

## SILICONE SPRAY

Use when grease cannot be applied.

## DUCT TAPE

Use to eliminate movement.

## CONFIRM THE REPAIR

Confirm that the cause of a noise is repaired by test driving the vehicle. Operate the vehicle under the same conditions as when the noise originally occurred. Refer to the notes on the Diagnostic Worksheet.

## Inspection Procedure

INFOID:000000007540703

Refer to Table of Contents for specific component removal and installation information.

## INSTRUMENT PANEL

Most incidents are caused by contact and movement between:

1. The cluster lid A and instrument panel
2. Acrylic lens and combination meter housing
3. Instrument panel to front pillar garnish
4. Instrument panel to windshield
5. Instrument panel mounting pins
6. Wiring harnesses behind the combination meter
7. A/C defroster duct and duct joint

These incidents can usually be located by tapping or moving the components to duplicate the noise or by pressing on the components while driving to stop the noise. Most of these incidents can be repaired by applying felt cloth tape or silicon spray (in hard to reach areas). Urethane pads can be used to insulate wiring harness.

### CAUTION:

**Do not use silicone spray to isolate a squeak or rattle. If you saturate the area with silicone, you will not be able to recheck the repair.**

## CENTER CONSOLE

Components to pay attention to include:

1. Shifter assembly cover to finisher
2. A/C control unit and cluster lid C
3. Wiring harnesses behind audio and A/C control unit

The instrument panel repair and isolation procedures also apply to the center console.

## DOORS

Pay attention to the:

1. Finisher and inner panel making a slapping noise
2. Inside handle escutcheon to door finisher
3. Wiring harnesses tapping
4. Door striker out of alignment causing a popping noise on starts and stops

Tapping or moving the components or pressing on them while driving to duplicate the conditions can isolate many of these incidents. You can usually insulate the areas with felt cloth tape or insulator foam blocks from the Nissan Squeak and Rattle Kit (J-43980) to repair the noise.

## TRUNK

Trunk noises are often caused by a loose jack or loose items put into the trunk by the owner.

In addition look for:

1. Trunk lid dumpers out of adjustment
2. Trunk lid striker out of adjustment



# SQUEAK AND RATTLE TROUBLE DIAGNOSES

< SYMPTOM DIAGNOSIS >

[WITHOUT ADP]

3. The trunk lid torsion bars knocking together

4. A loose license plate or bracket

Most of these incidents can be repaired by adjusting, securing or insulating the item(s) or component(s) causing the noise.

## SUNROOF/HEADLINING

Noises in the sunroof/headlining area can often be traced to one of the following:

1. Sunroof lid, rail, linkage or seals making a rattle or light knocking noise

2. Sunvisor shaft shaking in the holder

3. Front or rear windshield touching headlining and squeaking

Again, pressing on the components to stop the noise while duplicating the conditions can isolate most of these incidents. Repairs usually consist of insulating with felt cloth tape.

## SEATS

When isolating seat noise it's important to note the position the seat is in and the load placed on the seat when the noise is present. These conditions should be duplicated when verifying and isolating the cause of the noise.

Cause of seat noise include:

1. Headrest rods and holder

2. A squeak between the seat pad cushion and frame

3. The rear seatback lock and bracket

These noises can be isolated by moving or pressing on the suspected components while duplicating the conditions under which the noise occurs. Most of these incidents can be repaired by repositioning the component or applying urethane tape to the contact area.

## UNDERHOOD

Some interior noise may be caused by components under the hood or on the engine wall. The noise is then transmitted into the passenger compartment.

Causes of transmitted underhood noise include:

1. Any component mounted to the engine wall

2. Components that pass through the engine wall

3. Engine wall mounts and connectors

4. Loose radiator mounting pins

5. Hood bumpers out of adjustment

6. Hood striker out of adjustment

These noises can be difficult to isolate since they cannot be reached from the interior of the vehicle. The best method is to secure, move or insulate one component at a time and test drive the vehicle. Also, engine RPM or load can be changed to isolate the noise. Repairs can usually be made by moving, adjusting, securing, or insulating the component causing the noise.

A

B

C

D

E

F

G

H

I

J

K

MIR

M

N

O

P

# SQUEAK AND RATTLE TROUBLE DIAGNOSES

< SYMPTOM DIAGNOSIS >

[WITHOUT ADP]

## Diagnostic Worksheet

INFOID:000000007540704



### SQUEAK & RATTLE DIAGNOSTIC WORKSHEET

Dear Nissan Customer:

We are concerned about your satisfaction with your Nissan vehicle. Repairing a squeak or rattle sometimes can be very difficult. To help us fix your Nissan right the first time, please take a moment to note the area of the vehicle where the squeak or rattle occurs and under what conditions. You may be asked to take a test drive with a service advisor or technician to ensure we confirm the noise you are hearing.

#### I. WHERE DOES THE NOISE COME FROM? (circle the area of the vehicle)

The illustrations are for reference only, and may not reflect the actual configuration of your vehicle.

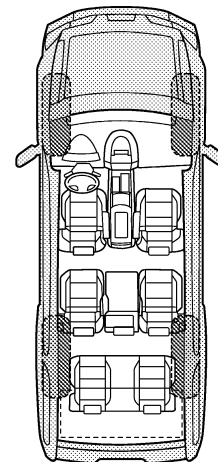
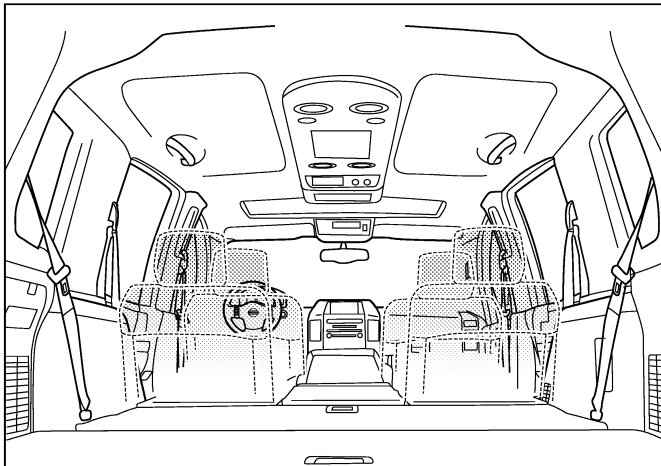
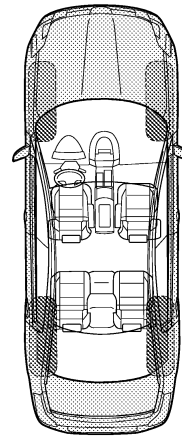
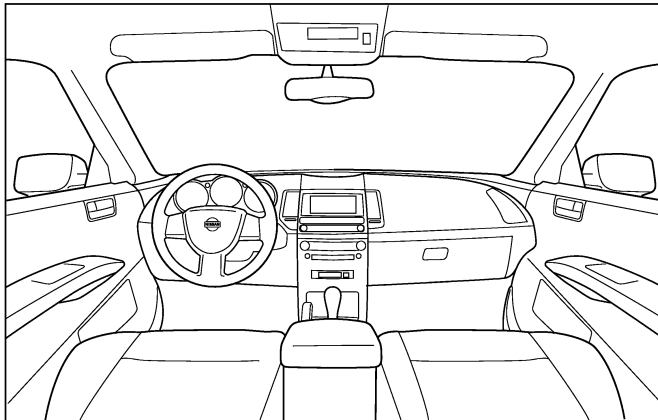

Continue to page 2 of the worksheet and briefly describe the location of the noise or rattle. In addition, please indicate the conditions which are present when the noise occurs.

PIIB8740E

# SQUEAK AND RATTLE TROUBLE DIAGNOSES

< SYMPTOM DIAGNOSIS >

[WITHOUT ADP]

## SQUEAK & RATTLE DIAGNOSTIC WORKSHEET - page 2

Briefly describe the location where the noise occurs:

---

---

### II. WHEN DOES IT OCCUR? (please check the boxes that apply)

- |   |  |
|---|--|
| <input type="checkbox"/> anytime                      | <input type="checkbox"/> after sitting out in the rain |
| <input type="checkbox"/> 1st time in the morning      | <input type="checkbox"/> when it is raining or wet     |
| <input type="checkbox"/> only when it is cold outside | <input type="checkbox"/> dry or dusty conditions       |
| <input type="checkbox"/> only when it is hot outside  | <input type="checkbox"/> other:                        |

### III. WHEN DRIVING:

- through driveways
- over rough roads
- over speed bumps
- only about \_\_\_\_ mph
- on acceleration
- coming to a stop
- on turns: left, right or either (circle)
- with passengers or cargo
- other: \_\_\_\_\_
- after driving \_\_\_\_ miles or \_\_\_\_ minutes

### IV. WHAT TYPE OF NOISE

- squeak (like tennis shoes on a clean floor)
- creak (like walking on an old wooden floor)
- rattle (like shaking a baby rattle)
- knock (like a knock at the door)
- tick (like a clock second hand)
- thump (heavy, muffled knock noise)
- buzz (like a bumble bee)

### TO BE COMPLETED BY DEALERSHIP PERSONNEL

#### Test Drive Notes:

---

---

---

	YES	NO	Initials of person performing
Vehicle test driven with customer	<input type="checkbox"/>	<input type="checkbox"/>	_____
- Noise verified on test drive	<input type="checkbox"/>	<input type="checkbox"/>	_____
- Noise source located and repaired	<input type="checkbox"/>	<input type="checkbox"/>	_____
- Follow up test drive performed to confirm repair	<input type="checkbox"/>	<input type="checkbox"/>	_____

VIN: \_\_\_\_\_ Customer Name: \_\_\_\_\_  
W.O.# \_\_\_\_\_ Date: \_\_\_\_\_

This form must be attached to Work Order

PIIB8742E

A  
B  
C  
D  
E  
F  
G  
H  
I  
J  
K  
M  
N  
O  
P

MIR

# PRECAUTIONS

< PRECAUTION >

[WITHOUT ADP]

## PRECAUTION

### PRECAUTIONS

#### FOR USA AND CANADA

#### FOR USA AND CANADA : Precaution for Supplemental Restraint System (SRS) "AIR BAG" and "SEAT BELT PRE-TENSIONER"

INFOID:000000007540705

The Supplemental Restraint System such as "AIR BAG" and "SEAT BELT PRE-TENSIONER", used along with a front seat belt, helps to reduce the risk or severity of injury to the driver and front passenger for certain types of collision. This system includes seat belt switch inputs and dual stage front air bag modules. The SRS system uses the seat belt switches to determine the front air bag deployment, and may only deploy one front air bag, depending on the severity of a collision and whether the front occupants are belted or unbelted. Information necessary to service the system safely is included in the "SRS AIR BAG" and "SEAT BELT" of this Service Manual.

#### **WARNING:**

Always observe the following items for preventing accidental activation.

- To avoid rendering the SRS inoperative, which could increase the risk of personal injury or death in the event of a collision that would result in air bag inflation, all maintenance must be performed by an authorized NISSAN/INFINITI dealer.
- Improper maintenance, including incorrect removal and installation of the SRS, can lead to personal injury caused by unintentional activation of the system. For removal of Spiral Cable and Air Bag Module, see "SRS AIR BAG".
- Never use electrical test equipment on any circuit related to the SRS unless instructed to in this Service Manual. SRS wiring harnesses can be identified by yellow and/or orange harnesses or harness connectors.

#### PRECAUTIONS WHEN USING POWER TOOLS (AIR OR ELECTRIC) AND HAMMERS

#### **WARNING:**

Always observe the following items for preventing accidental activation.

- When working near the Air Bag Diagnosis Sensor Unit or other Air Bag System sensors with the ignition ON or engine running, never use air or electric power tools or strike near the sensor(s) with a hammer. Heavy vibration could activate the sensor(s) and deploy the air bag(s), possibly causing serious injury.
- When using air or electric power tools or hammers, always switch the ignition OFF, disconnect the battery, and wait at least 3 minutes before performing any service.

#### FOR USA AND CANADA : Precaution for Procedure without Cowl Top Cover

INFOID:000000007540706

When performing the procedure after removing cowl top cover, cover the lower end of windshield with urethane, etc to prevent damage to windshield.

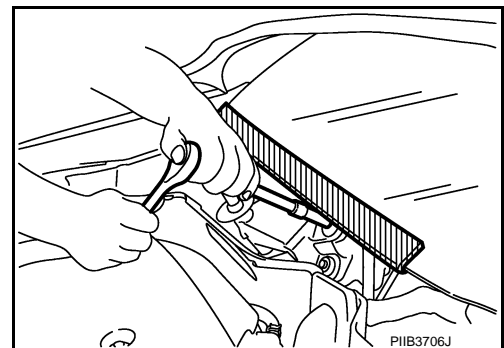

#### FOR USA AND CANADA : Precaution for Work

INFOID:000000007540707

- After removing and installing the opening/closing parts, be sure to carry out fitting adjustments to check their operation.
- Check the lubrication level, damage, and wear of each part. If necessary, grease or replace it.

#### FOR MEXICO

#### FOR MEXICO : Precaution for Supplemental Restraint System (SRS) "AIR BAG" and

# PRECAUTIONS

< PRECAUTION >

[WITHOUT ADP]

## "SEAT BELT PRE-TENSIONER"

INFOID:000000007540708

The Supplemental Restraint System such as "AIR BAG" and "SEAT BELT PRE-TENSIONER", used along with a front seat belt, helps to reduce the risk or severity of injury to the driver and front passenger for certain types of collision. Information necessary to service the system safely is included in the "SRS AIR BAG" and "SEAT BELT" of this Service Manual.

### **WARNING:**

Always observe the following items for preventing accidental activation.

- To avoid rendering the SRS inoperative, which could increase the risk of personal injury or death in the event of a collision that would result in air bag inflation, all maintenance must be performed by an authorized NISSAN/INFINITI dealer.
- Improper maintenance, including incorrect removal and installation of the SRS, can lead to personal injury caused by unintentional activation of the system. For removal of Spiral Cable and Air Bag Module, see "SRS AIR BAG".
- Never use electrical test equipment on any circuit related to the SRS unless instructed to in this Service Manual. SRS wiring harnesses can be identified by yellow and/or orange harnesses or harness connectors.

## PRECAUTIONS WHEN USING POWER TOOLS (AIR OR ELECTRIC) AND HAMMERS

### **WARNING:**

Always observe the following items for preventing accidental activation.

- When working near the Air Bag Diagnosis Sensor Unit or other Air Bag System sensors with the ignition ON or engine running, never use air or electric power tools or strike near the sensor(s) with a hammer. Heavy vibration could activate the sensor(s) and deploy the air bag(s), possibly causing serious injury.
- When using air or electric power tools or hammers, always switch the ignition OFF, disconnect the battery, and wait at least 3 minutes before performing any service.

## FOR MEXICO : Precaution for Procedure without Cowl Top Cover

INFOID:000000007540709

When performing the procedure after removing cowl top cover, cover the lower end of windshield with urethane, etc to prevent damage to windshield.

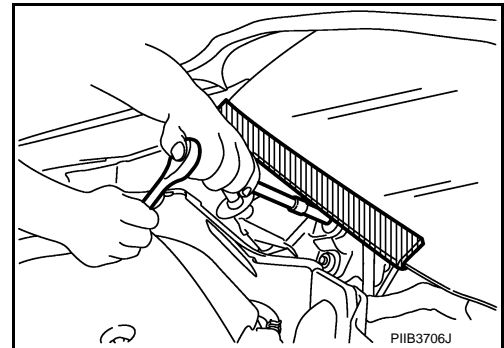

## FOR MEXICO : Precaution for Work

INFOID:000000007540710

- After removing and installing the opening/closing parts, be sure to carry out fitting adjustments to check their operation.
- Check the lubrication level, damage, and wear of each part. If necessary, grease or replace it.

A  
B  
C  
D  
E  
F  
G  
H  
I  
J  
K  
M  
N  
O  
P

MIR

# PREPARATION

< PREPARATION >

[WITHOUT ADP]

## PREPARATION

### PREPARATION

#### Special Service Tools

INFOID:000000007540711

The actual shapes of Kent-Moore tools may differ from those of special service tools illustrated here.

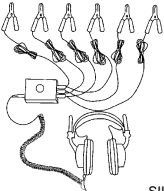
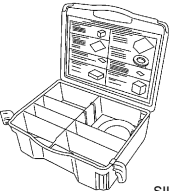
Tool number (Kent-Moore No.) Tool name	Description
(J-39570) Chassis ear   SIIA0993E	Locating the noise
(J-43980) NISSAN Squeak and Rattle Kit   SIIA0994E	Repairing the cause of noise

#### Commercial Service Tools

INFOID:000000007540712

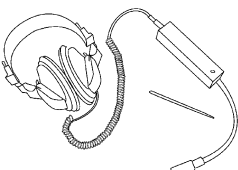
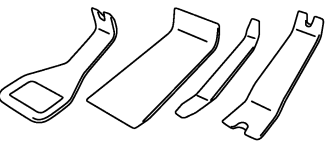
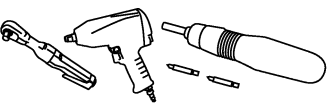
Tool name	Description
Engine ear   SIIA0995E	Locating the noise
Remover tool   PIIB7923J	Remove clips, pawls, metal clips
Power tool   PIIB1407E	

# INSIDE MIRROR

< REMOVAL AND INSTALLATION >

[WITHOUT ADP]

## REMOVAL AND INSTALLATION

### INSIDE MIRROR

Exploded View

INFOID:000000007540713

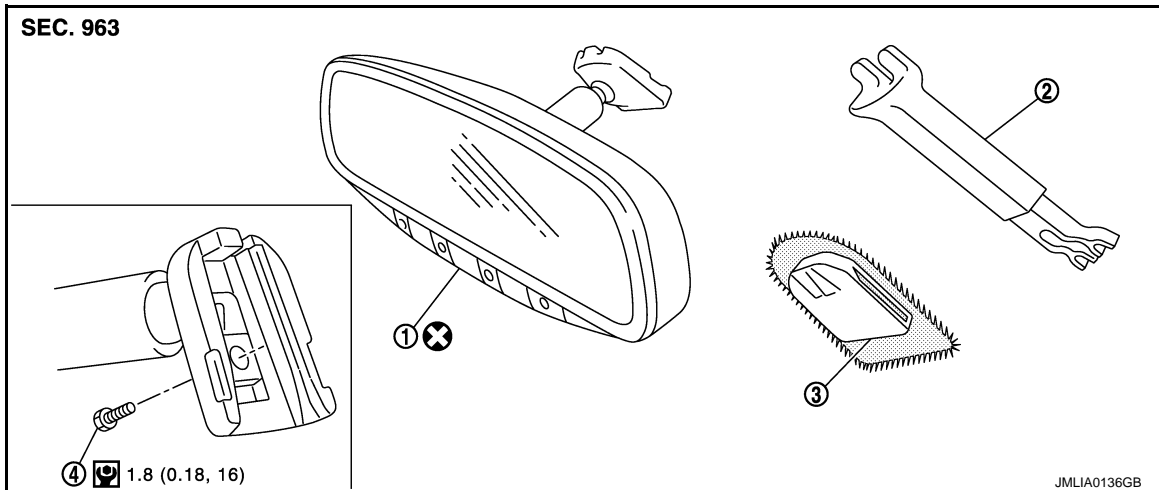

1. Inside mirror

2. Inside mirror cover

3. Mirror base

4. TORX bolt

Refer to [GI-4. "Components"](#) for symbols in the figure.

### Removal and Installation

INFOID:000000007540714

#### **CAUTION:**

**Never reuse the inside mirror disassembled from mirror base.**

#### REMOVAL

1. Remove the inside mirror cover.
2. Remove TORX bolt.
3. Slide the inside mirror upward to remove.

#### INSTALLATION

Install in the reverse order of removal.

#### **CAUTION:**

**When inserting the inside mirror into the mirror base, be sure to push the pawl until it get connected to the mirror base.**

A  
B  
C  
D  
E  
F  
G  
H  
I  
J  
K  
M  
N  
O  
P

MIR

# OUTSIDE MIRROR

< REMOVAL AND INSTALLATION >

[WITHOUT ADP]

## OUTSIDE MIRROR DOOR MIRROR ASSEMBLY

### DOOR MIRROR ASSEMBLY : Exploded View

INFOID:000000007540715

#### REMOVAL

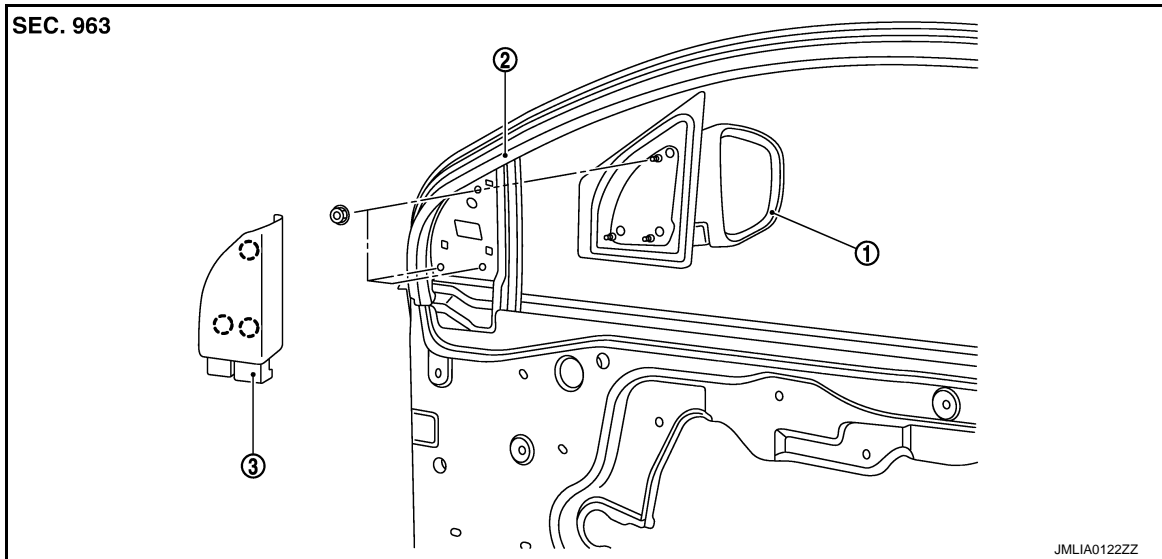

1. Door mirror assembly

2. Front door assembly

3. Door mirror corner cover

○ : Clip

#### DISASSEMBLY

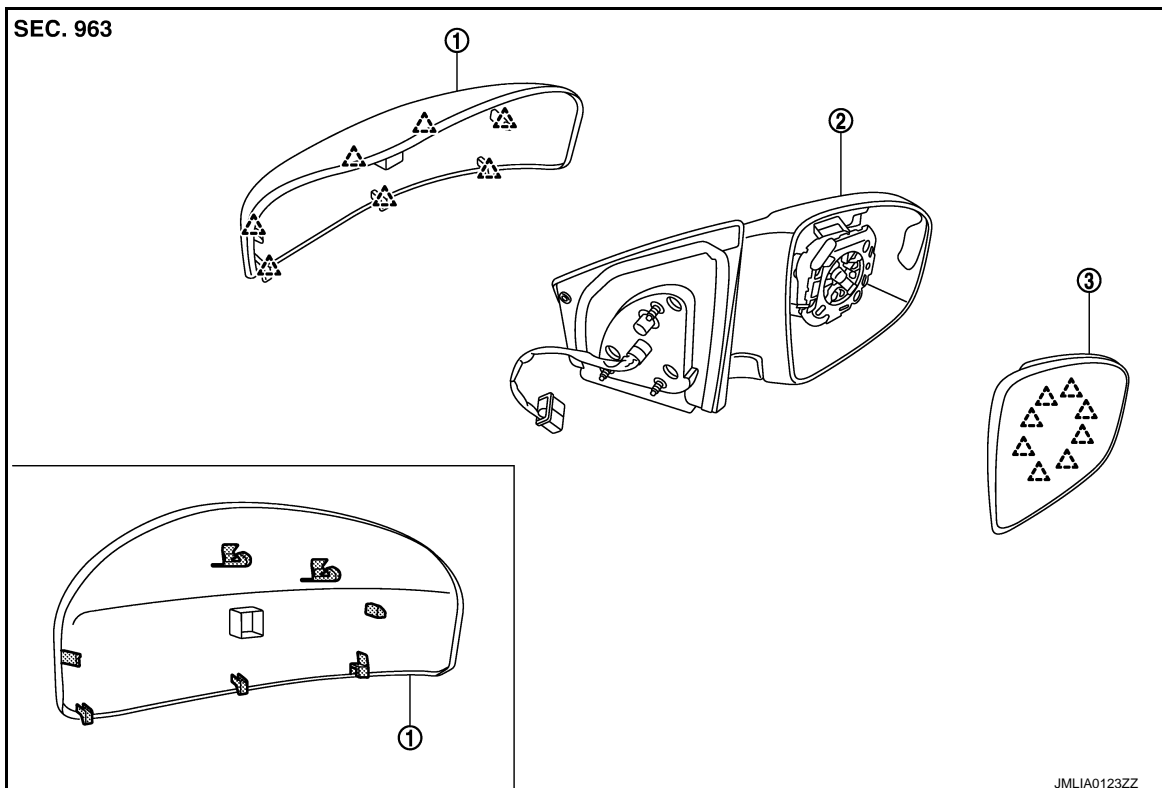



# OUTSIDE MIRROR

< REMOVAL AND INSTALLATION >

[WITHOUT ADP]

1. Door mirror cover
2. Door mirror assembly
3. Glass mirror

 : Pawl

## DOOR MIRROR ASSEMBLY : Removal and Installation

INFOID:000000007540716

### CAUTION:

Never damage the mirror bodies.

### REMOVAL

1. Remove the front door finisher. Refer to [INT-12. "FRONT DOOR FINISHER : Removal and Installation"](#).
2. Remove the door mirror corner cover.
3. Disconnect the door mirror harness connector.
4. Remove the door mirror mounting nuts, and remove the door mirror assembly.

### INSTALLATION

Install in the reverse order of removal.

## GLASS MIRROR

### GLASS MIRROR : Exploded View

INFOID:000000007540717

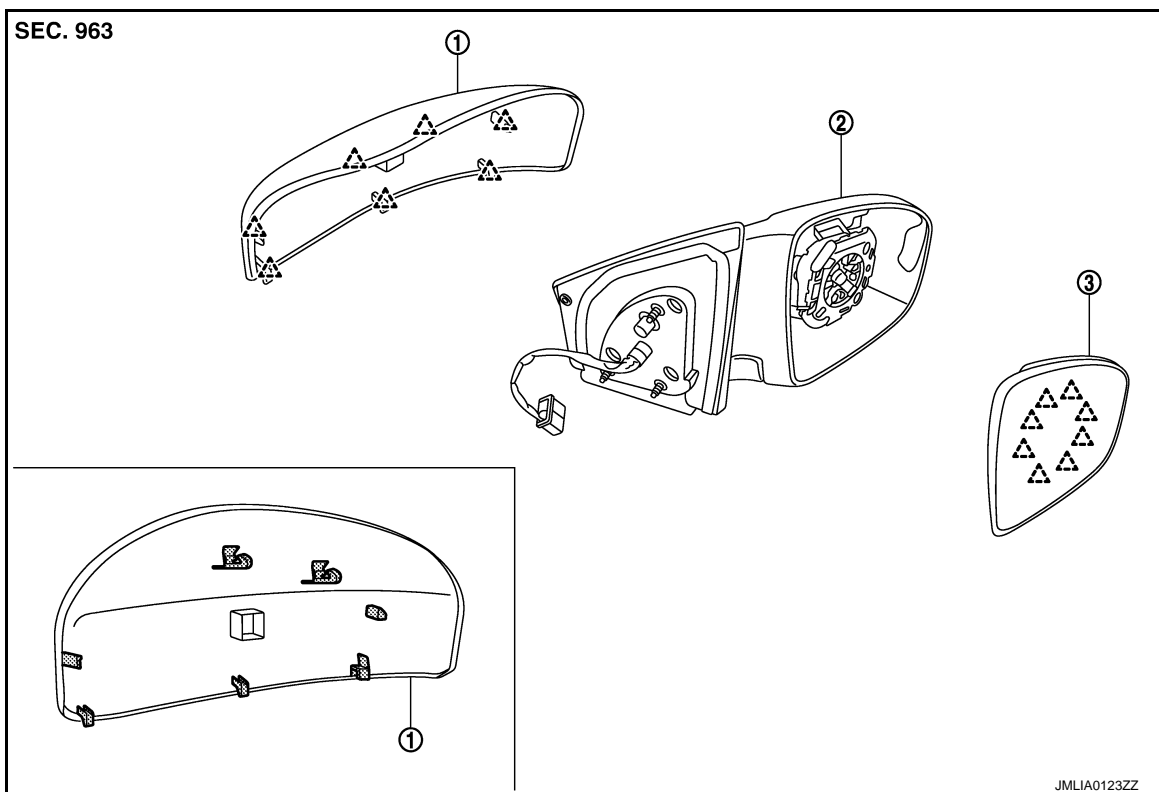

1. Door mirror cover
2. Door mirror assembly
3. Glass mirror

 : Pawl

## GLASS MIRROR : Disassembly and Assembly

INFOID:000000007540718

### CAUTION:

Never damage the mirror bodies.

### DISASSEMBLY

A  
B  
C  
D  
E  
F  
G  
H  
I  
J  
K  
L  
M  
N  
O  
P

MIR

# OUTSIDE MIRROR

## < REMOVAL AND INSTALLATION >

[WITHOUT ADP]

1. Place the glass mirror upward.
2. Put a strip of protective tape (A) on the housing.
3. Insert flat-bladed screwdriver (B) into the recess at lower side between glass mirror (1) and actuator (2), and push up pawls to remove glass mirror lower side.

**NOTE:**

Insert a small slotted screwdriver into recess, and push up while rotating (twist) to make work easier.

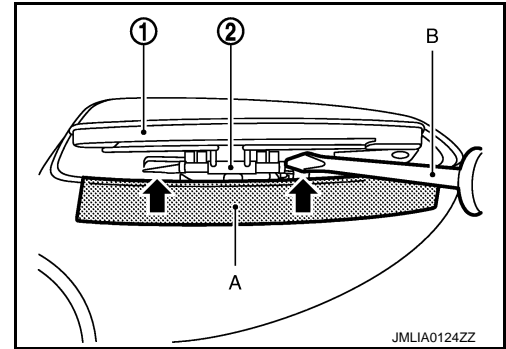

4. Insert flat-bladed screwdriver at RH/LH side between glass mirror and actuator, and push up pawls to remove glass mirror RH/LH side.

**NOTE:**

Insert flat-bladed screwdriver into recesses, and push up while rotating (twist) to make work easier.

5. Remove two terminals of mirror heater attachment. (With heater mirror model)
6. Pull glass mirror as shown in the figure in order to disengage both upper pawls, and then remove glass mirror.

1. Glass mirror
2. Actuator

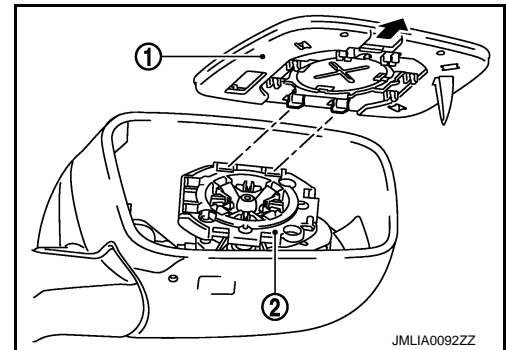

## ASSEMBLY

Install in the reverse order of removal.

**CAUTION:**

After installation, visually check that pawls are securely engaged.

## DOOR MIRROR COVER

# OUTSIDE MIRROR

< REMOVAL AND INSTALLATION >

[WITHOUT ADP]

## DOOR MIRROR COVER : Exploded View

INFOID:000000007540719

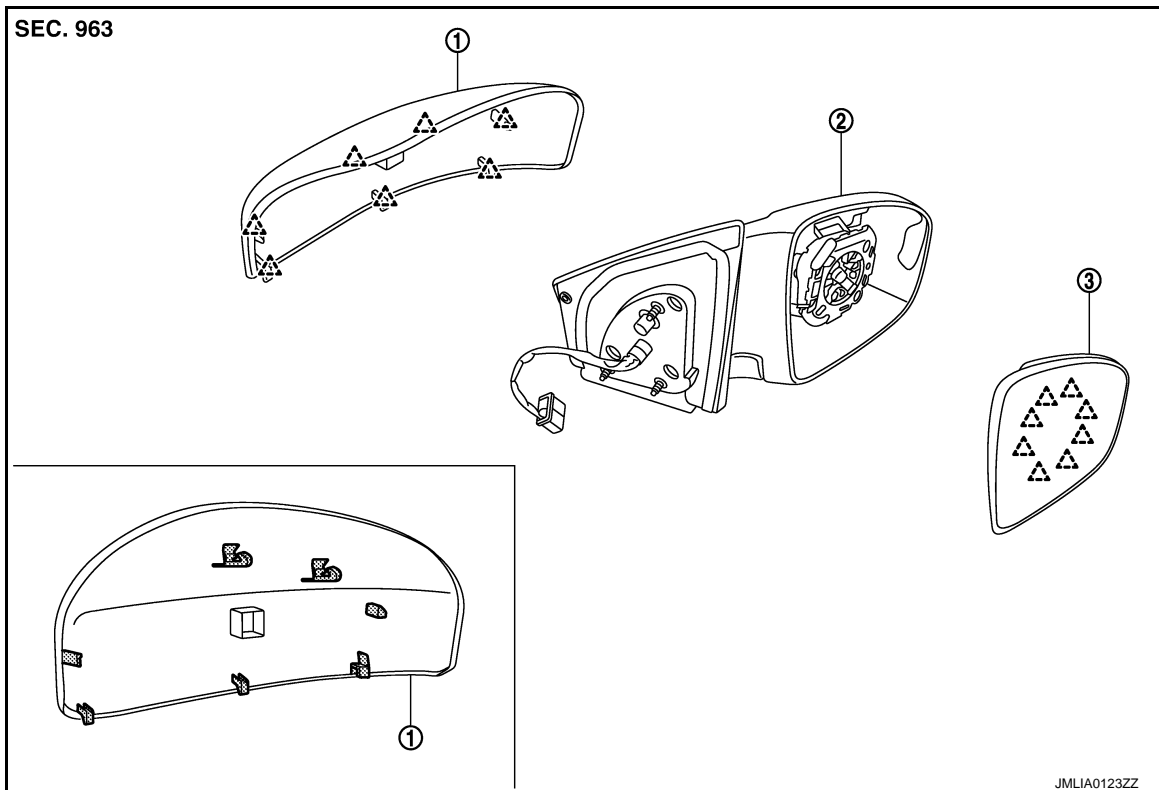

1. Door mirror cover

2. Door mirror assembly

3. Glass mirror

 : Pawl

## DOOR MIRROR COVER : Disassembly and Assembly

INFOID:000000007540720

### CAUTION:

Never damage the mirror bodies.

### DISASSEMBLY

1. Remove the glass mirror. Refer to [MIR-65. "GLASS MIRROR : Disassembly and Assembly"](#).
2. Remove the pawls, and disassemble the door mirror cover from the mirror assembly.

### ASSEMBLY

Install in the reverse order of removal.

### NOTE:

After installation, visually check that pawls are securely engaged.

A  
B  
C  
D  
E  
F  
G  
H  
I  
J  
K  
M  
N  
O  
P

MIR

# DOOR MIRROR REMOTE CONTROL SWITCH

< REMOVAL AND INSTALLATION >

[WITHOUT ADP]

## DOOR MIRROR REMOTE CONTROL SWITCH

### Exploded View

INFOID:000000007540721

Refer to [INT-12. "FRONT DOOR FINISHER : Exploded View"](#)

### Removal and Installation

INFOID:000000007540722

#### REMOVAL

1. Remove the power window main switch finisher (2). Refer to [PWC-92. "Removal and Installation"](#)
2. Remove door mirror remote control switch (1) from power window main switch finisher (2) using remover tool (A).

 : Pawl

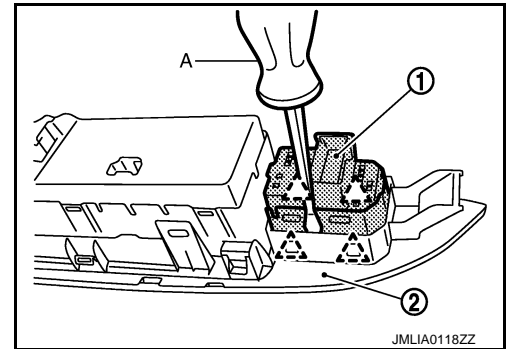

#### INSTALLATION

Install in the reverse order of removal.