

SECTION **BRC**

BRAKE CONTROL SYSTEM

A
B
C
D
E

CONTENTS

VDC/TCS/ABS	Component Description	19
BASIC INSPECTION	ABS	20
DIAGNOSIS AND REPAIR WORK FLOW	System Diagram	20
Work Flow	System Description	20
Diagnostic Work Sheet	Component Parts Location	20
INSPECTION AND ADJUSTMENT	Component Description	23
ADDITIONAL SERVICE WHEN REPLACING CONTROL UNIT	EBD	24
ADDITIONAL SERVICE WHEN REPLACING CONTROL UNIT : Description	System Diagram	24
ADDITIONAL SERVICE WHEN REPLACING CONTROL UNIT : Special Repair Requirement	System Description	24
ADJUSTMENT OF STEERING ANGLE SENSOR NEUTRAL POSITION	Component Parts Location	24
ADJUSTMENT OF STEERING ANGLE SENSOR NEUTRAL POSITION : Description	Component Description	27
ADJUSTMENT OF STEERING ANGLE SENSOR NEUTRAL POSITION : Special Repair Requirement	DIAGNOSIS SYSTEM [ABS ACTUATOR AND ELECTRIC UNIT (CONTROL UNIT)]	28
CALIBRATION OF DECEL G SENSOR	CONSULT Function	28
CALIBRATION OF DECEL G SENSOR : Description	DTC/CIRCUIT DIAGNOSIS	33
CALIBRATION OF DECEL G SENSOR : Special Repair Requirement	C1101, C1102, C1103, C1104 WHEEL SENSOR	33
SYSTEM DESCRIPTION	Description	33
VDC	DTC Logic	33
System Diagram	Diagnosis Procedure	33
System Description	Special Repair Requirement	36
Component Parts Location	C1105, C1106, C1107, C1108 WHEEL SENSOR	37
Component Description	Description	37
TCS	DTC Logic	37
System Diagram	Diagnosis Procedure	37
System Description	Special Repair Requirement	41
Component Parts Location	C1109 POWER AND GROUND SYSTEM	42
	Description	42
	DTC Logic	42
	Diagnosis Procedure	42
	Special Repair Requirement	43
	C1110 ABS ACTUATOR AND ELECTRIC UNIT (CONTROL UNIT)	44

BRC

G
H
I
J
K
L
M
N
O
P

Description	44	C1143 STEERING ANGLE SENSOR	68
DTC Logic	44	Description	68
Diagnosis Procedure	44	DTC Logic	68
Special Repair Requirement	44	Diagnosis Procedure	68
		Special Repair Requirement	70
C1111 ABS MOTOR, MOTOR RELAY SYSTEM	45	C1144 INCOMPLETE STEERING ANGLE SENSOR ADJUSTMENT	71
Description	45	Description	71
DTC Logic	45	DTC Logic	71
Diagnosis Procedure	45	Diagnosis Procedure	71
Special Repair Requirement	46	Special Repair Requirement	71
C1113, C1145, C1146 YAW RATE/SIDE/DECEL G SENSOR	47	C1155 BRAKE FLUID LEVEL SWITCH	73
Description	47	Description	73
DTC Logic	47	DTC Logic	73
Diagnosis Procedure	47	Diagnosis Procedure	73
Special Repair Requirement	48	Component Inspection	75
		Special Repair Requirement	75
C1115 WHEEL SENSOR	50	C1160 INCOMPLETE DECEL G SENSOR CALIBRATION	77
Description	50	Description	77
DTC Logic	50	DTC Logic	77
Diagnosis Procedure	50	Diagnosis Procedure	77
Special Repair Requirement	55	Special Repair Requirement	77
C1116 STOP LAMP SWITCH	56	C1161 INCOMPLETE SIDE G SENSOR CALIBRATION	79
Description	56	Description	79
DTC Logic	56	DTC Logic	79
Diagnosis Procedure	56	Diagnosis Procedure	79
Component Inspection	57	Special Repair Requirement	79
Special Repair Requirement	57		
C1120, C1122, C1124, C1126 IN ABS SOL	58	C1162 INCOMPLETE PRESSURE SENSOR CALIBRATION	80
Description	58	Description	80
DTC Logic	58	DTC Logic	80
Diagnosis Procedure	58	Diagnosis Procedure	80
Special Repair Requirement	59	Special Repair Requirement	80
C1121, C1123, C1125, C1127 OUT ABS SOL..	60	C1164, C1165 CV SYSTEM	81
Description	60	Description	81
DTC Logic	60	DTC Logic	81
Diagnosis Procedure	60	Diagnosis Procedure	81
Special Repair Requirement	61	Special Repair Requirement	82
C1130 ENGINE SIGNAL	62	C1166, C1167 SV SYSTEM	83
Description	62	Description	83
DTC Logic	62	DTC Logic	83
Diagnosis Procedure	62	Diagnosis Procedure	83
Special Repair Requirement	62	Special Repair Requirement	84
C1140 ACTUATOR RELAY SYSTEM	64	U1000 CAN COMM CIRCUIT	85
Description	64	Description	85
DTC Logic	64	DTC Logic	85
Diagnosis Procedure	64	Diagnosis Procedure	85
Special Repair Requirement	65	Special Repair Requirement	85
C1142 PRESS SENSOR	66	U1002 SYSTEM COMM (CAN)	87
Description	66	Description	87
DTC Logic	66		
Diagnosis Procedure	66		
Special Repair Requirement	67		

DTC Logic	87	Diagnosis Procedure	110	
Diagnosis Procedure	87	THE BRAKING DISTANCE IS LONG	111	A
Special Repair Requirement	88	Diagnosis Procedure	111	
POWER SUPPLY AND GROUND CIRCUIT	89	ABS FUNCTION DOES NOT OPERATE	112	B
Description	89	Diagnosis Procedure	112	
Diagnosis Procedure	89	PEDAL VIBRATION OR ABS OPERATION		C
Special Repair Requirement	90	SOUND OCCURS	113	
PARKING BRAKE SWITCH	92	Diagnosis Procedure	113	
Component Function Check	92	VEHICLE JERKS DURING VDC/TCS/ABS		D
Diagnosis Procedure	92	CONTROL	114	
Component Inspection	92	Diagnosis Procedure	114	
VDC OFF SWITCH	94	NORMAL OPERATING CONDITION	115	E
Description	94	Description	115	
Component Function Check	94	PRECAUTION	116	BRC
Diagnosis Procedure	94	PRECAUTIONS	116	
Component Inspection	95	FOR USA AND CANADA	116	G
Special Repair Requirement	95	FOR USA AND CANADA : Precaution for Supplemental Restraint System (SRS) "AIR BAG" and "SEAT BELT PRE-TENSIONER"	116	H
ABS WARNING LAMP	96	FOR USA AND CANADA : Precaution for Procedure without Cowl Top Cover	116	I
Description	96	FOR USA AND CANADA : Precaution for Brake System	116	J
Component Function Check	96	FOR USA AND CANADA : Precaution for Brake Control	117	K
Diagnosis Procedure	96	FOR USA AND CANADA : Precaution for Harness Repair	117	L
Special Repair Requirement	96	FOR MEXICO	118	M
BRAKE WARNING LAMP	97	FOR MEXICO : Precaution for Supplemental Restraint System (SRS) "AIR BAG" and "SEAT BELT PRE-TENSIONER"	118	N
Description	97	FOR MEXICO : Precaution for Procedure without Cowl Top Cover	118	O
Component Function Check	97	FOR MEXICO : Precaution for Brake System	118	P
Diagnosis Procedure	97	FOR MEXICO : Precaution for Brake Control	119	
Special Repair Requirement	97	FOR MEXICO : Precaution for Harness Repair	119	
VDC WARNING LAMP	99	REMOVAL AND INSTALLATION	121	
Description	99	WHEEL SENSOR	121	
Component Function Check	99	FRONT WHEEL SENSOR	121	
Diagnosis Procedure	99	FRONT WHEEL SENSOR : Exploded View	121	
Special Repair Requirement	99	FRONT WHEEL SENSOR : Removal and Installation	121	
VDC OFF INDICATOR LAMP	100	REAR WHEEL SENSOR	122	
Description	100	REAR WHEEL SENSOR : Exploded View	122	
Component Function Check	100	REAR WHEEL SENSOR : Removal and Installation	122	
Diagnosis Procedure	100	SENSOR ROTOR	124	
Special Repair Requirement	101	FRONT SENSOR ROTOR	124	
ECU DIAGNOSIS INFORMATION	102			
ABS ACTUATOR AND ELECTRIC UNIT (CONTROL UNIT)	102			
Reference Value	102			
Wiring Diagram -BRAKE CONTROL SYSTEM- ..	105			
Fail-Safe	106			
DTC No. Index	107			
SYMPTOM DIAGNOSIS	109			
EXCESSIVE ABS FUNCTION OPERATION FREQUENCY	109			
Diagnosis Procedure	109			
UNEXPECTED PEDAL REACTION	110			

FRONT SENSOR ROTOR : Exploded View	124	Removal and Installation	125
FRONT SENSOR ROTOR : Removal and Installation	124	YAW RATE/SIDE/DECEL G SENSOR	127
REAR SENSOR ROTOR	124	Exploded View	127
REAR SENSOR ROTOR : Exploded View	124	Removal and Installation	127
REAR SENSOR ROTOR : Removal and Installation	124	STEERING ANGLE SENSOR	128
ABS ACTUATOR AND ELECTRIC UNIT (CONTROL UNIT)	125	Exploded View	128
Exploded View	125	Removal and Installation	128
		VDC OFF SWITCH	129
		Removal and Installation	129

BASIC INSPECTION

DIAGNOSIS AND REPAIR WORK FLOW

Work Flow

INFOID:000000008457231

PRECAUTIONS FOR DIAGNOSIS

Adjustment of Steering Angle Sensor

If steering angle sensor, steering system parts, suspension system parts, ABS actuator and electric unit (control unit) or tires have been replaced, or if wheel alignment has been adjusted, be sure to adjust neutral position of steering angle sensor before driving. Refer to [BRC-9, "ADJUSTMENT OF STEERING ANGLE SENSOR NEUTRAL POSITION : Description"](#).

Calibration of Decel G Sensor

If yaw rate/side/decel G sensor or ABS actuator and electric unit (control unit) have been replaced, be sure to calibrate decel G sensor before driving. Refer to [BRC-10, "CALIBRATION OF DECEL G SENSOR : Description"](#).

A
B
C
D
E
G
H
I
J
K
L
M
N
O
P

BRC

DIAGNOSIS AND REPAIR WORK FLOW

< BASIC INSPECTION >

[VDC/TCS/ABS]

OVERALL SEQUENCE

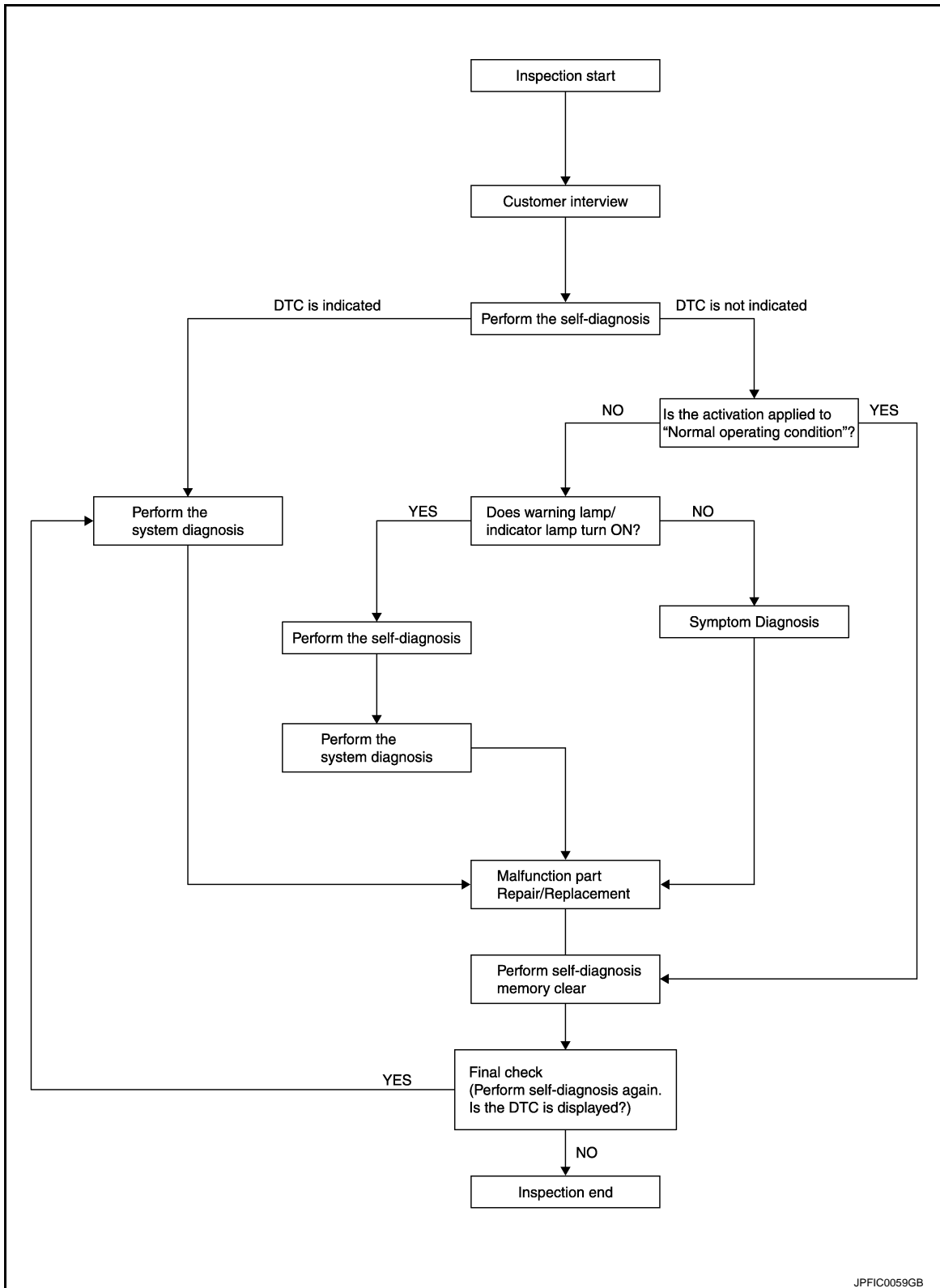

JPFIC0059GB

DETAILED FLOW

1. COLLECT THE INFORMATION FROM THE CUSTOMER

Get the detailed information from the customer about the symptom (the condition and the environment when the incident/malfunction occurred) using the diagnosis worksheet. Refer to [BRC-8, "Diagnostic Work Sheet"](#).

>> GO TO 2.

DIAGNOSIS AND REPAIR WORK FLOW

[VDC/TCS/ABS]

< BASIC INSPECTION >

2. PERFORM SELF-DIAGNOSIS

Perform self-diagnosis with CONSULT.

Is there any DTC displayed?

- YES >> Record or print self-diagnosis results and freeze frame data (FFD). GO TO 3.
NO >> GO TO 4.

3. PERFORM THE SYSTEM DIAGNOSIS

Perform the diagnosis applicable to the displayed DTC of "ABS" with CONSULT. Refer to [BRC-107, "DTC No. Index"](#).

>> GO TO 7.

4. CHECK THE SYMPTOM THAT IS NOT CONSIDERED A SYSTEM MALFUNCTION

Check that the symptom is a normal operation that is not considered a system malfunction. Refer to [BRC-115, "Description"](#).

Is the symptom a normal operation?

- YES >> GO TO 8.
NO >> GO TO 5.

5. CHECK THE WARNING LAMP AND INDICATOR LAMP FOR ILLUMINATION

Check that the warning lamp and indicator lamp illuminate.

- ABS warning lamp: Refer to [BRC-96, "Description"](#).
- Brake warning lamp: Refer to [BRC-97, "Description"](#).
- VDC warning lamp: Refer to [BRC-99, "Description"](#).
- VDC OFF indicator lamp: Refer to [BRC-100, "Description"](#).

Is ON/OFF timing normal?

- YES >> GO TO 6.
NO >> GO TO 2.

6. PERFORM SELF-DIAGNOSIS

Perform self-diagnosis for "ABS" with CONSULT.

>> GO TO 7.

7. REPAIR OR REPLACE THE MALFUNCTIONING PARTS

Repair or replace the specified malfunctioning parts.

>> GO TO 8.

8. MEMORY CLEAR

Perform self-diagnosis memory clear for "ABS" with CONSULT.

>> GO TO 9.

9. FINAL CHECK

Perform the self-diagnosis again, and check that the malfunction is repaired completely.

Is no other DTC present and the repair completed?

- YES >> INSPECTION END
NO >> GO TO 3.

A
B
C
D
E
G
H
I
J
K
L
M
N
O
P

BRC

DIAGNOSIS AND REPAIR WORK FLOW

< BASIC INSPECTION >

[VDC/TCS/ABS]

Diagnostic Work Sheet

INFOID:000000008457232

Customer name MR/MS	Model & Year	VIN	
Engine #	Trans.	Mileage	
Incident Date	Manuf. Date	In Service Date	
Symptoms	<input type="checkbox"/> Noise and vibration (from engine compartment) <input type="checkbox"/> Noise and vibration (from axle)	<input type="checkbox"/> Warning / Indicator activate	<input type="checkbox"/> Firm pedal operation <input type="checkbox"/> Large stroke pedal operation
	<input type="checkbox"/> TCS does not work (Rear wheels slip when accelerating)	<input type="checkbox"/> ABS does not work (Wheels lock when braking)	<input type="checkbox"/> Lack of sense of acceleration
Engine conditions	<input type="checkbox"/> When starting <input type="checkbox"/> After starting		
Road conditions	<input type="checkbox"/> Low friction road (<input type="checkbox"/> Snow <input type="checkbox"/> Gravel <input type="checkbox"/> Other) <input type="checkbox"/> Bumps / potholes		
Driving conditions	<input type="checkbox"/> Full-acceleration <input type="checkbox"/> High speed cornering <input type="checkbox"/> Vehicle speed: Greater than 10 km/h (6 MPH) <input type="checkbox"/> Vehicle speed: 10 km/h (6 MPH) or less <input type="checkbox"/> Vehicle is stopped		
Applying brake conditions	<input type="checkbox"/> Suddenly <input type="checkbox"/> Gradually		
Other conditions	<input type="checkbox"/> Operation of electrical equipment <input type="checkbox"/> Shift change <input type="checkbox"/> Other descriptions		

SFIA3265E

INSPECTION AND ADJUSTMENT

< BASIC INSPECTION >

[VDC/TCS/ABS]

INSPECTION AND ADJUSTMENT

ADDITIONAL SERVICE WHEN REPLACING CONTROL UNIT

ADDITIONAL SERVICE WHEN REPLACING CONTROL UNIT : Description

INFOID:000000008457233

Perform the steering angle sensor adjustment and decel G sensor calibration after replacing the ABS actuator and electric unit (control unit).

ADDITIONAL SERVICE WHEN REPLACING CONTROL UNIT : Special Repair Requirement

INFOID:000000008457234

1. PERFORM ADJUSTMENT OF STEERING ANGLE SENSOR AND CALIBRATION OF DECEL G SENSOR

Perform steering angle sensor adjustment and decel G sensor calibration.

- Adjustment of steering angle sensor: Refer to [BRC-9, "ADJUSTMENT OF STEERING ANGLE SENSOR NEUTRAL POSITION : Description"](#).
- Calibration of decel G sensor: Refer to [BRC-10, "CALIBRATION OF DECEL G SENSOR : Description"](#).

>> INSPECTION END

ADJUSTMENT OF STEERING ANGLE SENSOR NEUTRAL POSITION

ADJUSTMENT OF STEERING ANGLE SENSOR NEUTRAL POSITION : Description

INFOID:000000008457235

When doing work that applies to the list below, make sure to adjust neutral position of steering angle sensor before running vehicle.

x: Required –: Not required

Situation	Adjustment of steering angle sensor neutral position
Removing/Installing ABS actuator and electric unit (control unit)	—
Replacing ABS actuator and electric unit (control unit)	x
Removing/Installing steering angle sensor	x
Replacing steering angle sensor	x
Removing/Installing steering components	x
Replacing steering components	x
Removing/Installing suspension components	x
Replacing suspension components	x
Change tires to new ones	—
Tire rotation	—
Adjusting wheel alignment	x

ADJUSTMENT OF STEERING ANGLE SENSOR NEUTRAL POSITION : Special Repair Requirement

INFOID:000000008457236

ADJUSTMENT OF STEERING ANGLE SENSOR NEUTRAL POSITION

CAUTION:

**To adjust neutral position of steering angle sensor, make sure to use CONSULT.
(Adjustment cannot be done without CONSULT.)**

1. ALIGN THE VEHICLE STATUS

Stop the vehicle with front wheels in straight-ahead position.

>> GO TO 2.

2. PERFORM THE NEUTRAL POSITION ADJUSTMENT FOR THE STEERING ANGLE SENSOR

A
B
C
D
E
BRC

G
H
I
J
K
L
M
N
O
P

INSPECTION AND ADJUSTMENT

[VDC/TCS/ABS]

< BASIC INSPECTION >

1. Select "ABS", "WORK SUPPORT" and "ST ANGLE SENSOR ADJUSTMENT" in order with CONSULT.
2. Select "START".

CAUTION:

Never touch steering wheel while adjusting steering angle sensor.

3. After approximately 10 seconds, select "END".

NOTE:

After approximately 60 seconds, it ends automatically.

4. Turn the ignition switch OFF, then turn it ON again.

CAUTION:

Be sure to perform above operation.

>> GO TO 3.

3. CHECK DATA MONITOR

1. Run the vehicle with front wheels in straight-ahead position, then stop.
2. Select "ABS", "DATA MONITOR" and "STR ANGLE SIG" in order with CONSULT, and check the steering angle sensor signal.

STR ANGLE SIG : $0 \pm 3.5^\circ$

Is the steering angle within the specified range?

YES >> GO TO 4.

NO >> Perform the neutral position adjustment for the steering angle sensor again, GO TO 1.

4. ERASE THE SELF-DIAGNOSIS MEMORY

Erase the self-diagnosis memories for "ABS" with CONSULT. Refer to [BRC-28. "CONSULT Function"](#).

Are the memories erased?

YES >> INSPECTION END

NO >> Check the items indicated by the self-diagnosis.

CALIBRATION OF DECEL G SENSOR

CALIBRATION OF DECEL G SENSOR : Description

INFOID:000000008457237

When doing work that applies to the list below, make sure to calibration of decel G sensor before running vehicle.

×: Required —: Not required

Situation	Calibration of decel G sensor
Removing/Installing ABS actuator and electric unit (control unit)	×
Replacing ABS actuator and electric unit (control unit)	×
Removing/Installing steering components	—
Removing/Installing suspension components	—
Change tires to new ones	—
Tire rotation	—
Adjusting wheel alignment	—
Removing/Installing yaw rate/side/decel G sensor	×
Replacing yaw rate/side/decel G sensor	×

CALIBRATION OF DECEL G SENSOR : Special Repair Requirement

INFOID:000000008457238

CALIBRATION OF DECEL G SENSOR

CAUTION:

- To calibrate decel G sensor, make sure to use CONSULT.
(Calibration cannot be done without CONSULT.)
- Perform the G sensor calibration only with the vehicle parked on level surface.

1. ALIGN THE VEHICLE STATUS

INSPECTION AND ADJUSTMENT

< BASIC INSPECTION >

[VDC/TCS/ABS]

Stop the vehicle with front wheels in straight-ahead position.

CAUTION:

- Keep all tires inflated to correct pressures. Adjust the tire pressure to the specified pressure value.
- Check that there is specified-load in vehicle other than the driver (or equivalent weight placed in driver's position).

>> GO TO 2.

2.PERFORM THE CALIBRATION OF DECEL G SENSOR

1. Select "ABS", "WORK SUPPORT" and "DECEL G SEN CALIBRATION" in order with CONSULT.
2. Select "START".
3. After approximately 10 seconds, select "END".

NOTE:

After approximately 60 seconds, it ends automatically.

4. Turn the ignition switch OFF, then turn it ON again.

CAUTION:

Be sure to perform above operation.

>> GO TO 3.

3.CHECK DATA MONITOR

1. Run the vehicle with front wheels in straight-ahead position, then stop.
2. Select "ABS", "DATA MONITOR" and "DECEL G-SEN" in order with CONSULT, and check the decel G sensor signal.

DECEL G-SEN : ±0.08 G

Is the yaw rate/side/decel G sensor within the specified range?

YES >> GO TO 4.

NO >> Perform the calibration of decel G sensor again, GO TO 1.

4.ERASE THE SELF-DIAGNOSIS MEMORY

Erase the self-diagnosis memories for "ABS" with CONSULT. Refer to [BRC-28. "CONSULT Function"](#).

Are the memories erased?

YES >> INSPECTION END

NO >> Check the items indicated by the self-diagnosis.

A
B
C
D
E
BRC
G
H
I
J
K
L
M
N
O
P

SYSTEM DESCRIPTION

VDC

System Diagram

INFOID:000000008457239

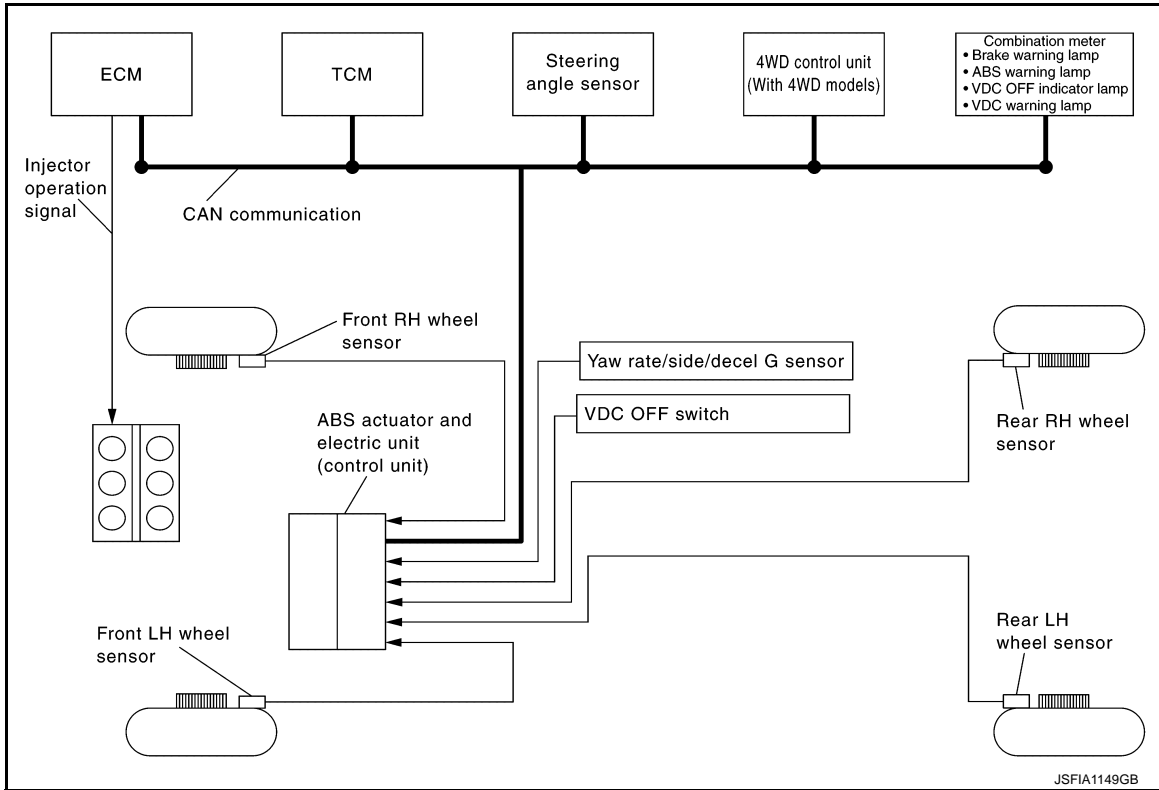

System Description

INFOID:000000008457240

- In addition to the TCS/ABS function, the driver steering amount and brake operation amount are detected by the steering angle sensor and pressure sensor, and the vehicle's driving status (amount of under steering/over steering) is determined by the information from the yaw rate/side/decel G sensor, wheel sensor, etc., and this information is used to improve vehicle stability by controlling the braking and engine power to all four wheels.
- During VDC operation, it informs driver of system operation by blinking the VDC warning lamp.
- Electrical system diagnosis by CONSULT is available.

Component Parts Location

INFOID:000000008457241

FOR USA

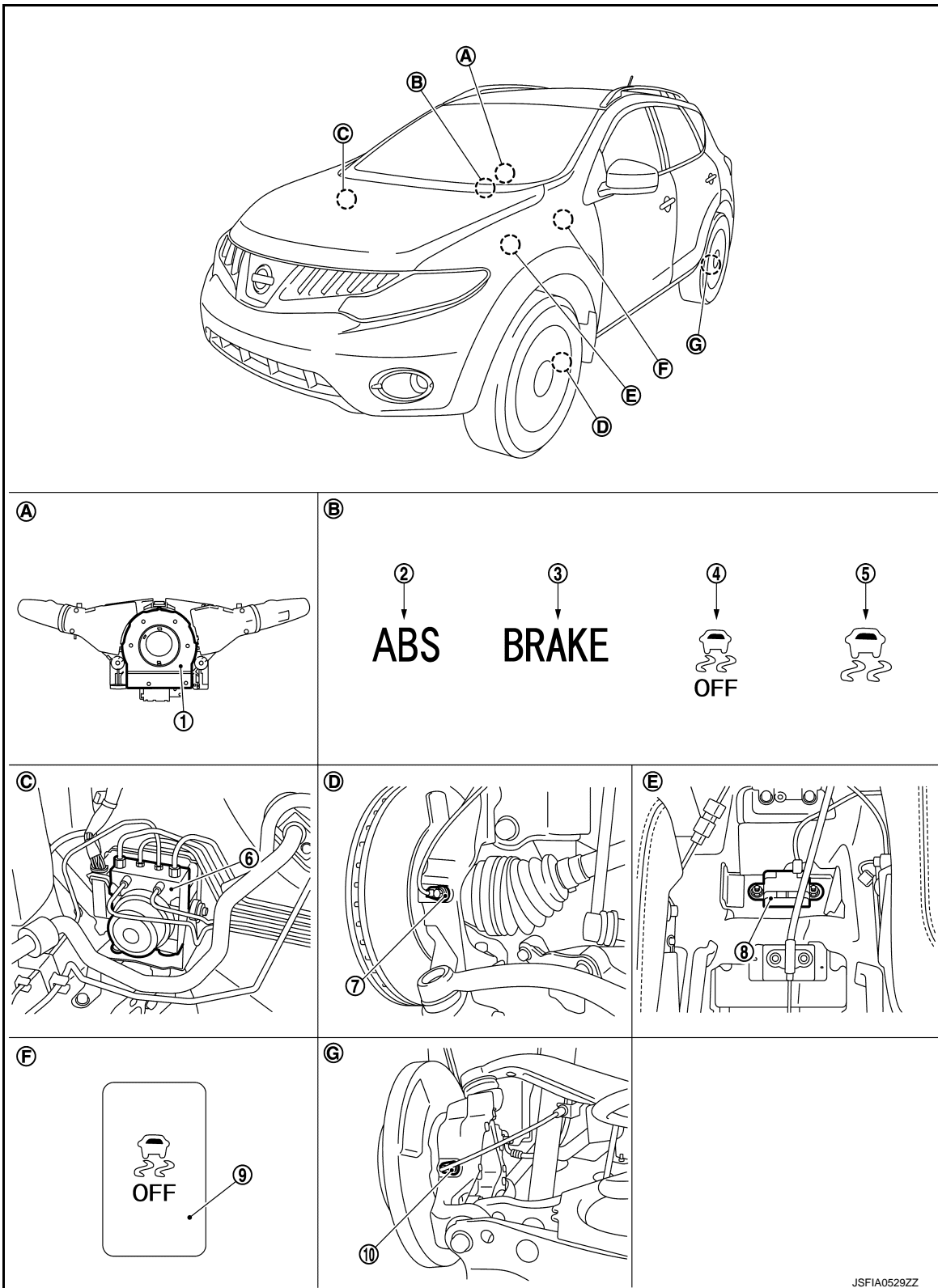

- | | | |
|---------------------------|---------------------------------|--|
| 1. Steering angle sensor | 2. ABS warning lamp | 3. Brake warning lamp |
| 4. VDC OFF indicator lamp | 5. VDC warning lamp | 6. ABS actuator and electric unit (control unit) |
| 7. Front wheel sensor | 8. Yaw rate/side/decel G sensor | 9. VDC OFF switch |
| 10. Rear wheel sensor | | |

JSFIA0529ZZ

A
B
C
D
E
BRC
G
H
I
J
K
L
M
N
O
P

< SYSTEM DESCRIPTION >

- A. Back of spiral cable assembly
- B. Combination meter
- C. Engine room (right side)
- D. Steering knuckle
- E. Under center console
- F. Instrument driver lower panel
- G. Rear axle

EXCEPT FOR USA

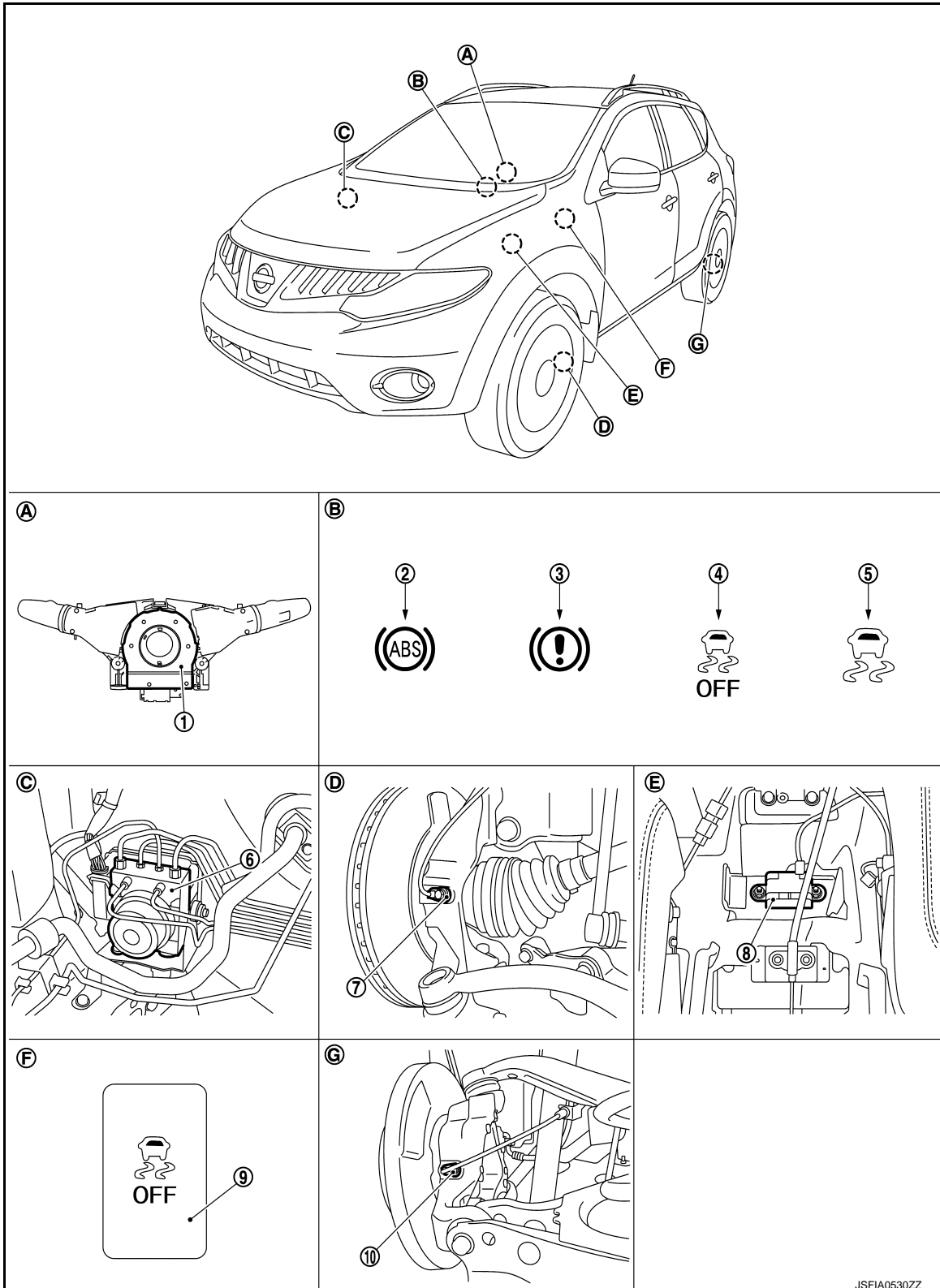

JSFIA0530ZZ

VDC

< SYSTEM DESCRIPTION >

[VDC/TCS/ABS]

- | | | | |
|----------------------------------|---------------------------------|--|---|
| 1. Steering angle sensor | 2. ABS warning lamp | 3. Brake warning lamp | A |
| 4. VDC OFF indicator lamp | 5. VDC warning lamp | 6. ABS actuator and electric unit (control unit) | |
| 7. Front wheel sensor | 8. Yaw rate/side/decel G sensor | 9. VDC OFF switch | B |
| 10. Rear wheel sensor | | | |
| A. Back of spiral cable assembly | B. Combination meter | C. Engine room (right side) | C |
| D. Steering knuckle | E. Under center console | F. Instrument driver lower panel | |
| G. Rear axle | | | |

Component Description

INFOID:000000008457242

Component parts		Reference
ABS actuator and electric unit (control unit)	Pump	BRC-45, "Description"
	Motor	
	Actuator relay (Main relay)	BRC-64, "Description"
	ABS IN valve	BRC-58, "Description"
	ABS OUT valve	BRC-60, "Description"
	Cut valve 1 (CV1), cut valve 2 (CV2)	BRC-81, "Description"
	Suction valve 1 (SV1), suction valve 2 (SV2)	BRC-83, "Description"
Wheel sensor	BRC-33, "Description"	
Yaw rate/side/decel G sensor	BRC-47, "Description"	
Steering angle sensor	BRC-68, "Description"	
VDC OFF switch	BRC-94, "Description"	
ABS warning lamp	BRC-96, "Description"	
Brake warning lamp	BRC-97, "Description"	
VDC warning lamp	BRC-99, "Description"	
VDC OFF indicator lamp	BRC-100, "Description"	

A
B
C
D
E
BRC
G
H
I
J
K
L
M
N
O
P

TCS

System Diagram

INFOID:000000008457243

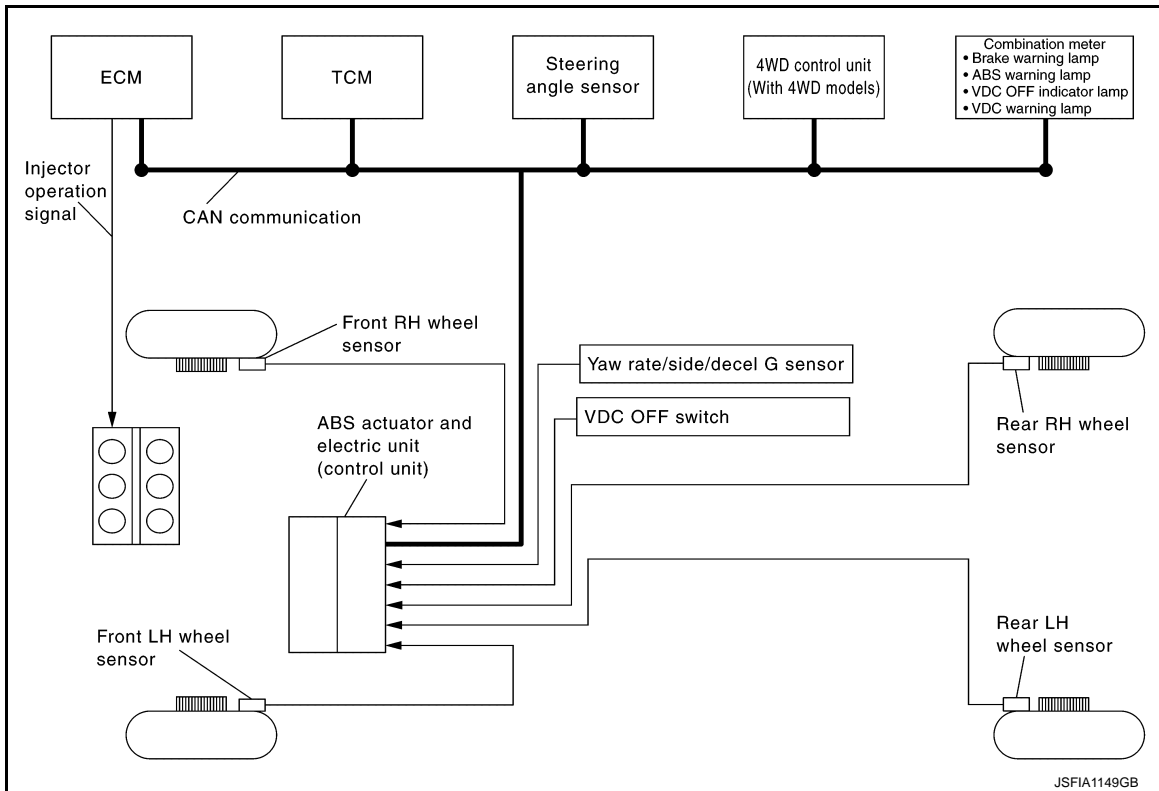

System Description

INFOID:000000008457244

- The wheel spin of the drive wheels is detected by the ABS actuator and electric unit (control unit) using the wheel speed signals from the four wheels, so if wheel spin occurs, the drive wheel right and left brake fluid pressure control and engine fuel cut are conducted while the throttle valve opening is restricted to reduce the engine torque and decrease the amount of wheel spin. In addition, the throttle opening is controlled to achieve the optimum engine torque.
- During TCS operation, TCS informs driver of system operation by blinking the VDC warning lamp.
- Electrical system diagnosis by CONSULT is available.

Component Parts Location

INFOID:000000008457245

FOR USA

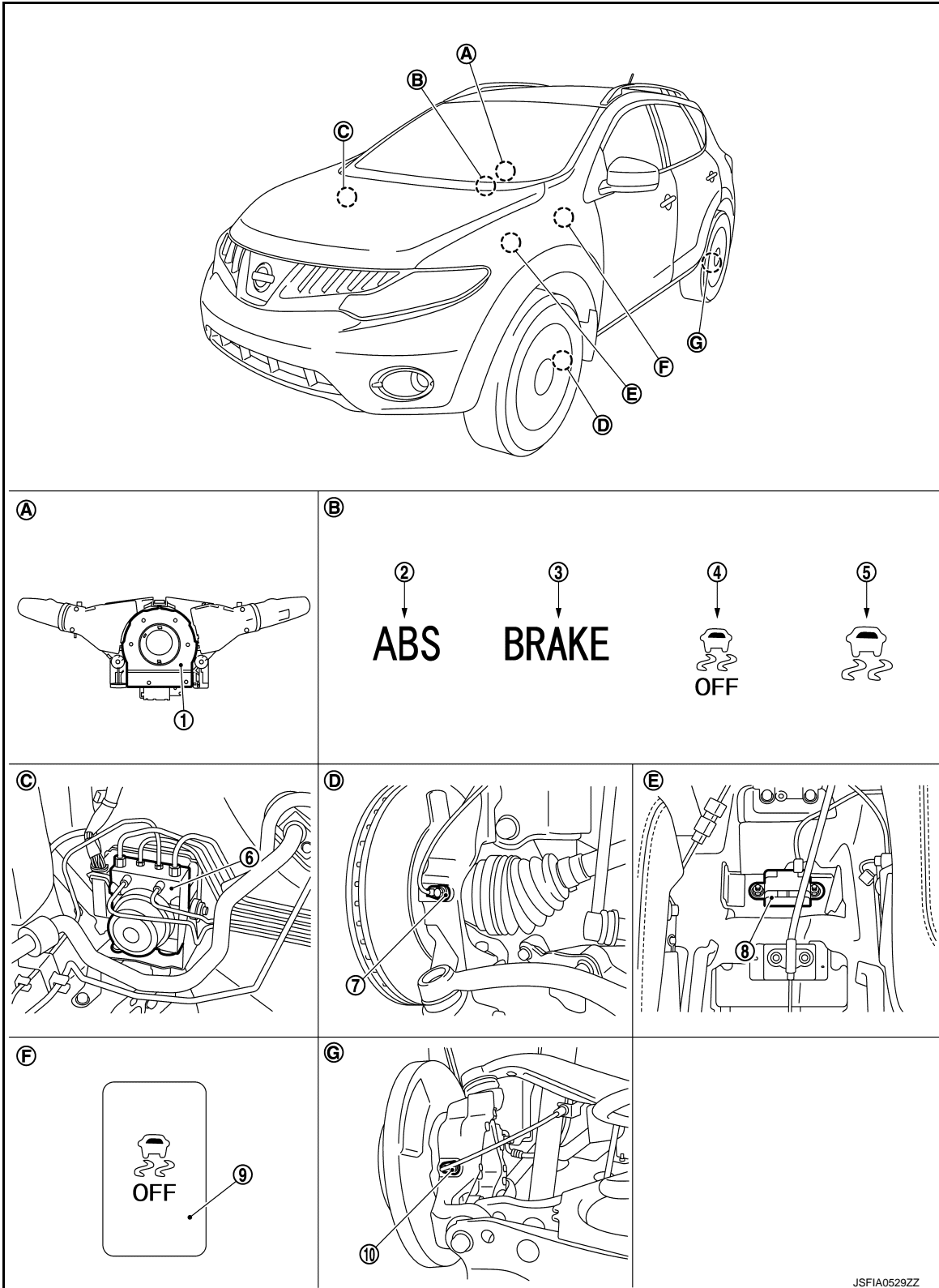

- | | | |
|---------------------------|---------------------------------|--|
| 1. Steering angle sensor | 2. ABS warning lamp | 3. Brake warning lamp |
| 4. VDC OFF indicator lamp | 5. VDC warning lamp | 6. ABS actuator and electric unit (control unit) |
| 7. Front wheel sensor | 8. Yaw rate/side/decel G sensor | 9. VDC OFF switch |
| 10. Rear wheel sensor | | |

A
B
C
D
E
BRC
G
H
I
J
K
L
M
N
O
P

TCS

[VDC/TCS/ABS]

< SYSTEM DESCRIPTION >

- A. Back of spiral cable assembly
- B. Combination meter
- C. Engine room (right side)
- D. Steering knuckle
- E. Under center console
- F. Instrument driver lower panel
- G. Rear axle

EXCEPT FOR USA

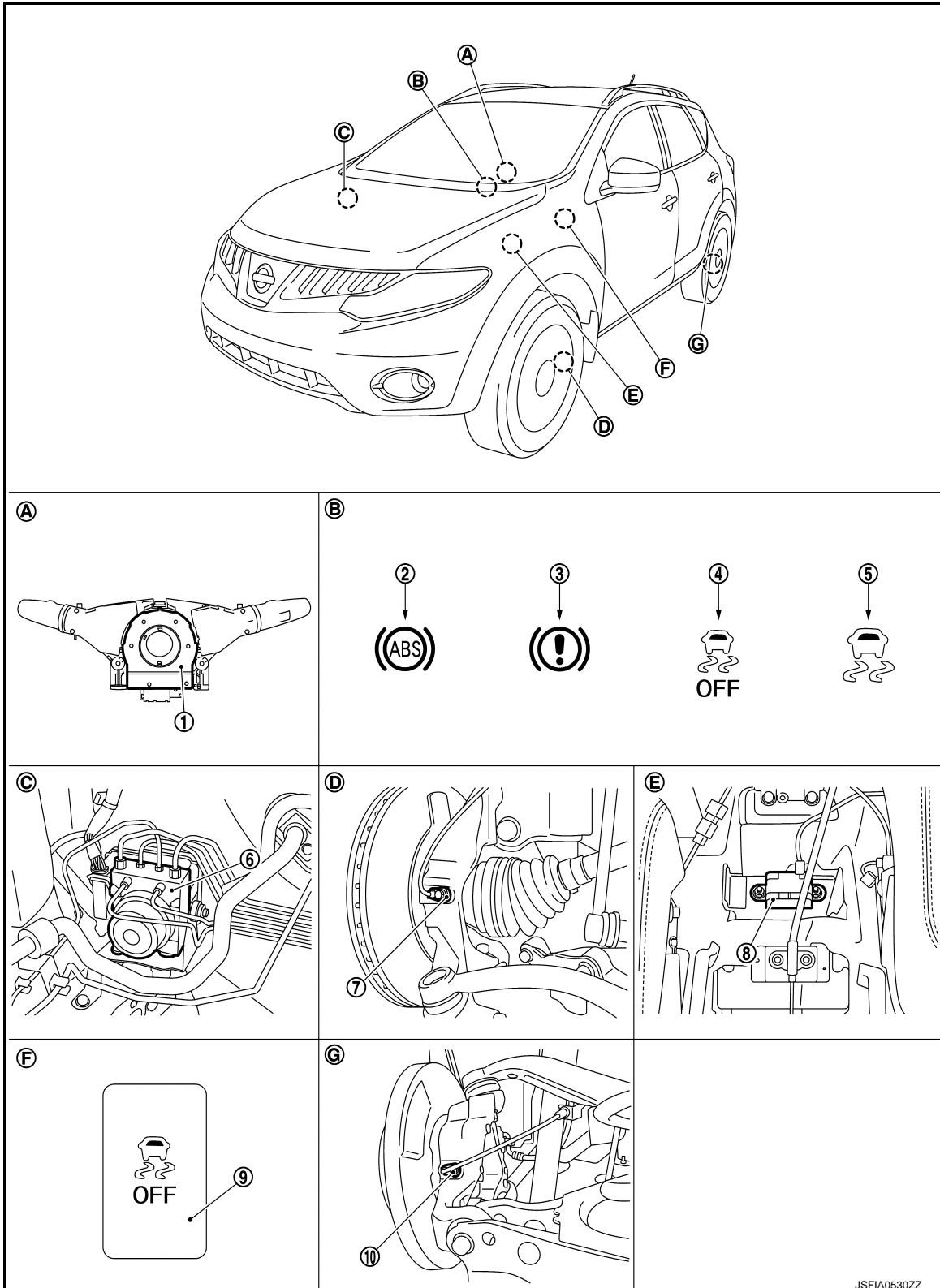

< SYSTEM DESCRIPTION >

- | | | | |
|----------------------------------|---------------------------------|--|---|
| 1. Steering angle sensor | 2. ABS warning lamp | 3. Brake warning lamp | A |
| 4. VDC OFF indicator lamp | 5. VDC warning lamp | 6. ABS actuator and electric unit (control unit) | |
| 7. Front wheel sensor | 8. Yaw rate/side/decel G sensor | 9. VDC OFF switch | B |
| 10. Rear wheel sensor | | | |
| A. Back of spiral cable assembly | B. Combination meter | C. Engine room (right side) | C |
| D. Steering knuckle | E. Under center console | F. Instrument driver lower panel | |
| G. Rear axle | | | |

Component Description

INFOID:000000008457246

Component parts		Reference
ABS actuator and electric unit (control unit)	Pump	BRC-45, "Description"
	Motor	
	Actuator relay (Main relay)	BRC-64, "Description"
	ABS IN valve	BRC-58, "Description"
	ABS OUT valve	BRC-60, "Description"
	Cut valve 1 (CV1), cut valve 2 (CV2)	BRC-81, "Description"
	Suction valve 1 (SV1), suction valve 2 (SV2)	BRC-83, "Description"
Wheel sensor	BRC-33, "Description"	
Yaw rate/side/decel G sensor	BRC-47, "Description"	
Steering angle sensor	BRC-68, "Description"	
VDC OFF switch	BRC-94, "Description"	
ABS warning lamp	BRC-96, "Description"	
Brake warning lamp	BRC-97, "Description"	
VDC warning lamp	BRC-99, "Description"	
VDC OFF indicator lamp	BRC-100, "Description"	

A
B
C
D
E
BRC
G
H
I
J
K
L
M
N
O
P

ABS

System Diagram

INFOID:000000008457247

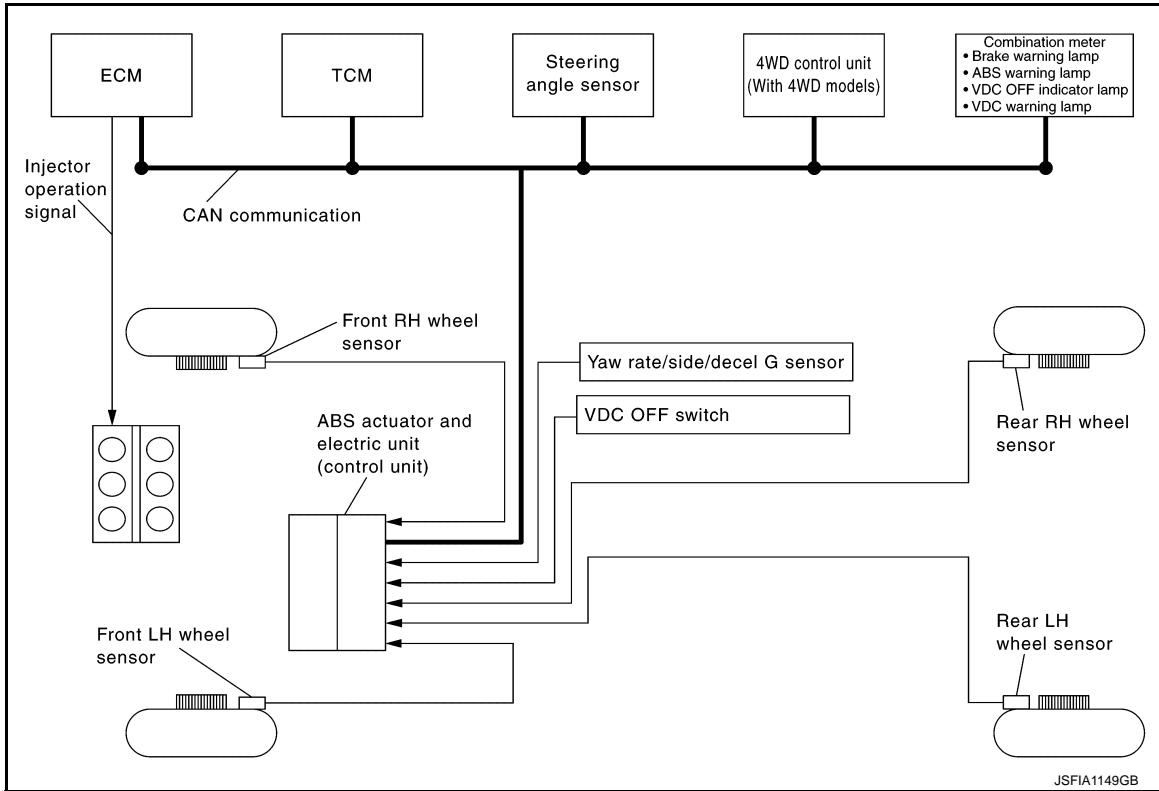

System Description

INFOID:000000008457248

- The Anti-Lock Braking System detects wheel revolution while braking, and it improves handling stability during sudden braking by electrically preventing 4 wheel lock. Maneuverability is also improved for avoiding obstacles.
- Electrical system diagnosis by CONSULT is available.

Component Parts Location

INFOID:000000008457249

FOR USA

ABS

< SYSTEM DESCRIPTION >

[VDC/TCS/ABS]

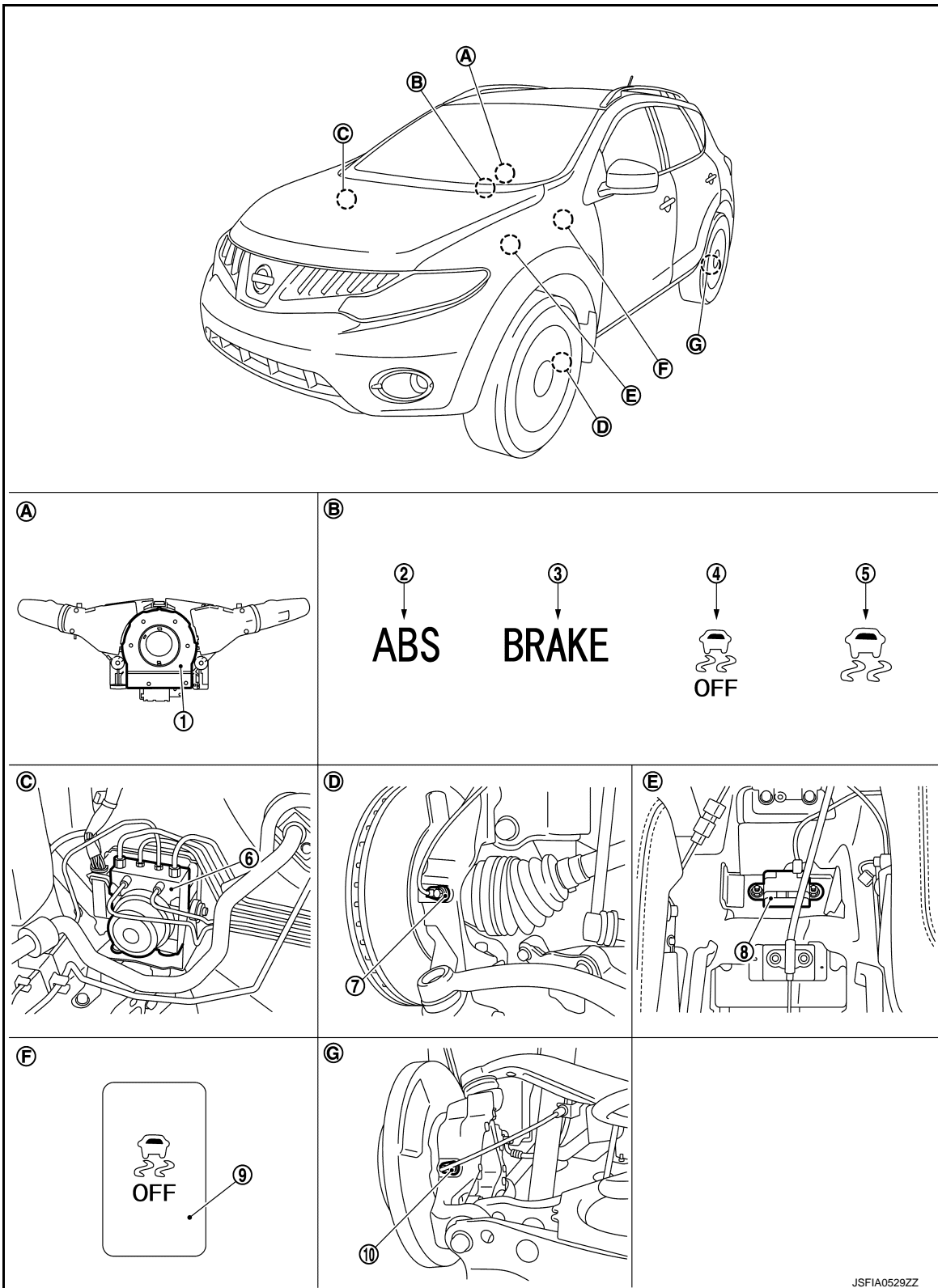

- | | | |
|---------------------------|---------------------------------|--|
| 1. Steering angle sensor | 2. ABS warning lamp | 3. Brake warning lamp |
| 4. VDC OFF indicator lamp | 5. VDC warning lamp | 6. ABS actuator and electric unit (control unit) |
| 7. Front wheel sensor | 8. Yaw rate/side/decel G sensor | 9. VDC OFF switch |
| 10. Rear wheel sensor | | |

JSFIA0529ZZ

A
B
C
D
E
BRC
G
H
I
J
K
L
M
N
O
P

ABS

[VDC/TCS/ABS]

< SYSTEM DESCRIPTION >

- A. Back of spiral cable assembly
- B. Combination meter
- C. Engine room (right side)
- D. Steering knuckle
- E. Under center console
- F. Instrument driver lower panel
- G. Rear axle

EXCEPT FOR USA

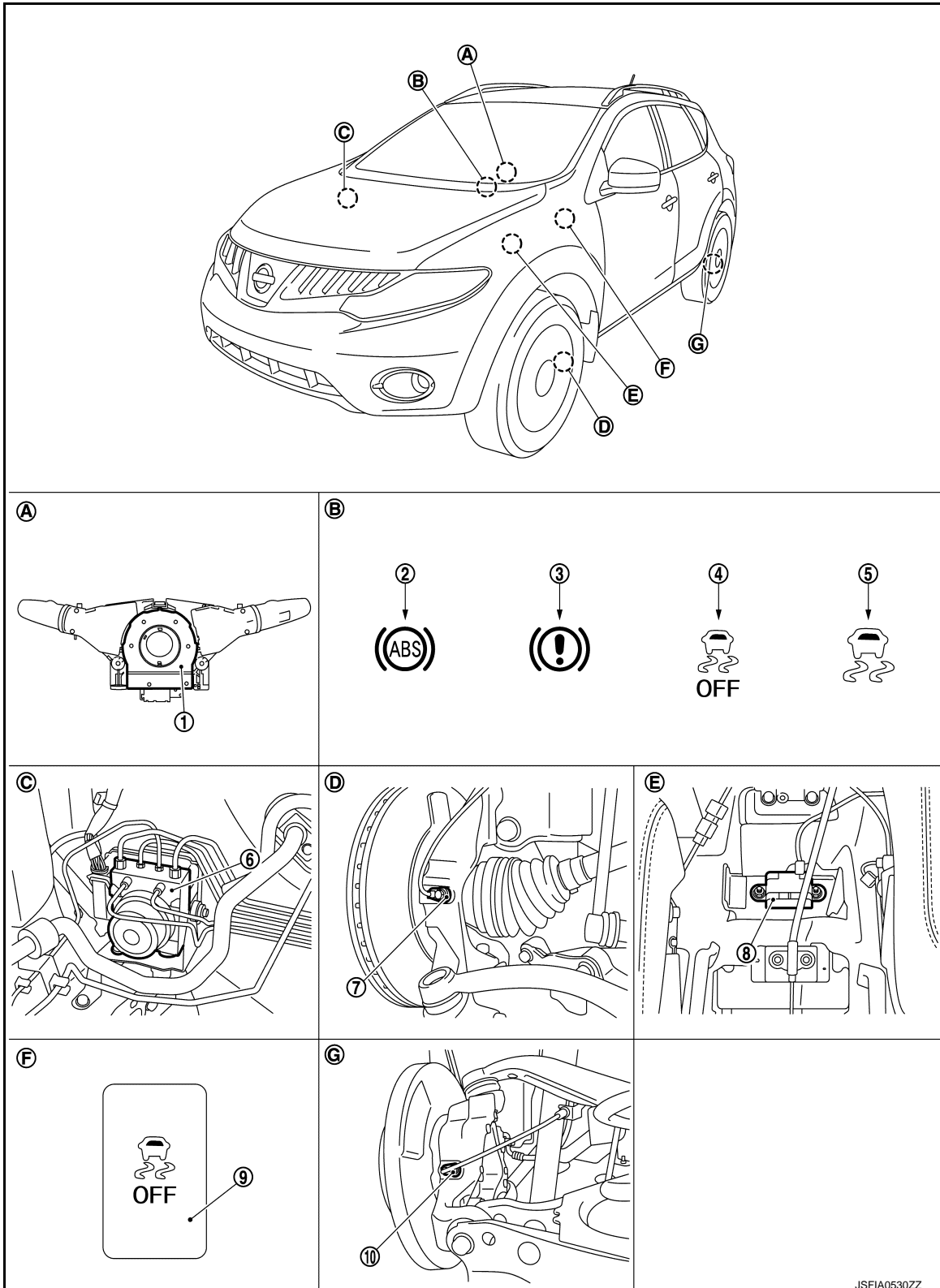

JSFIA0530ZZ

ABS

< SYSTEM DESCRIPTION >

[VDC/TCS/ABS]

- | | | | |
|----------------------------------|---------------------------------|--|---|
| 1. Steering angle sensor | 2. ABS warning lamp | 3. Brake warning lamp | A |
| 4. VDC OFF indicator lamp | 5. VDC warning lamp | 6. ABS actuator and electric unit (control unit) | |
| 7. Front wheel sensor | 8. Yaw rate/side/decel G sensor | 9. VDC OFF switch | B |
| 10. Rear wheel sensor | | | |
| A. Back of spiral cable assembly | B. Combination meter | C. Engine room (right side) | C |
| D. Steering knuckle | E. Under center console | F. Instrument driver lower panel | |
| G. Rear axle | | | |

Component Description

INFOID:000000008457250

Component parts	Reference	
ABS actuator and electric unit (control unit)	Pump	BRC-45, "Description"
	Motor	
	Actuator relay (Main relay)	BRC-64, "Description"
	ABS IN valve	BRC-58, "Description"
	ABS OUT valve	BRC-60, "Description"
	Cut valve 1 (CV1), cut valve 2 (CV2)	BRC-81, "Description"
	Suction valve 1 (SV1), suction valve 2 (SV2)	BRC-83, "Description"
Wheel sensor	BRC-33, "Description"	
Yaw rate/side/decel G sensor	BRC-47, "Description"	
Steering angle sensor	BRC-68, "Description"	
VDC OFF switch	BRC-94, "Description"	
ABS warning lamp	BRC-96, "Description"	
Brake warning lamp	BRC-97, "Description"	
VDC warning lamp	BRC-99, "Description"	
VDC OFF indicator lamp	BRC-100, "Description"	

A
B
C
D
E
BRC
G
H
I
J
K
L
M
N
O
P

EBD

System Diagram

INFOID:000000008457251

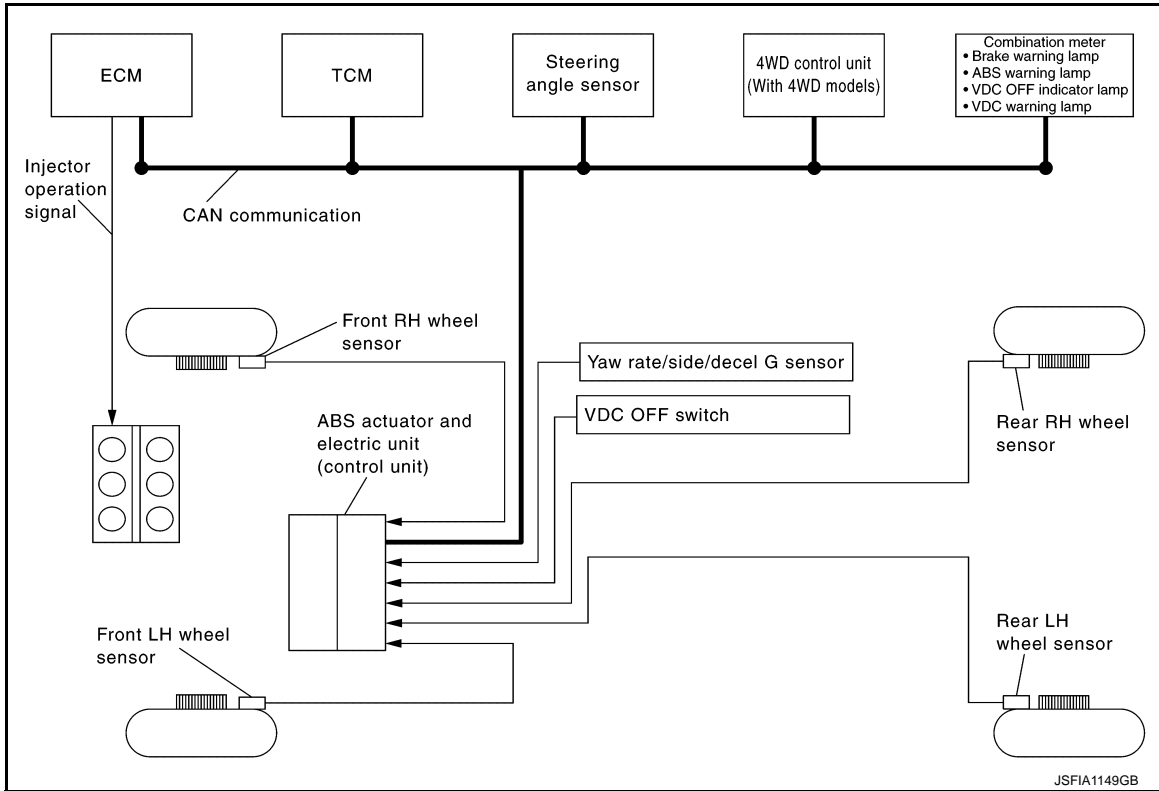

JSFIA1149GB

System Description

INFOID:000000008457252

- Electronic Brake force Distribution detects subtle slippages between front and rear wheels during braking, and it improves handling stability by electronically controlling brake fluid pressure which results in reduced rear wheel slippage.
- Electrical system diagnosis by CONSULT is available.

Component Parts Location

INFOID:000000008457253

FOR USA

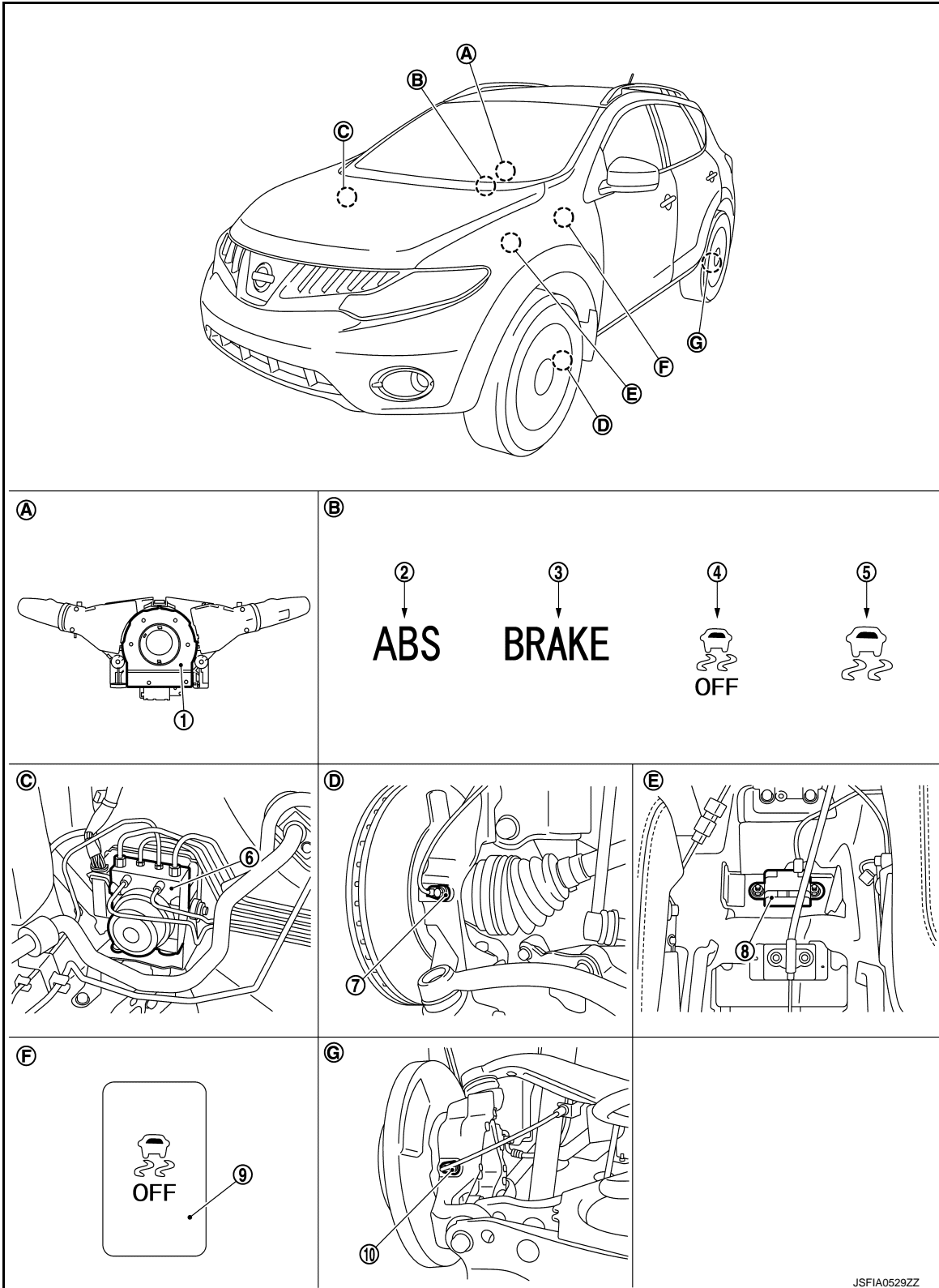

A
B
C
D
E
BRC
G
H
I
J
K
L
M
N
O
P

- | | | |
|---------------------------|---------------------------------|--|
| 1. Steering angle sensor | 2. ABS warning lamp | 3. Brake warning lamp |
| 4. VDC OFF indicator lamp | 5. VDC warning lamp | 6. ABS actuator and electric unit (control unit) |
| 7. Front wheel sensor | 8. Yaw rate/side/decel G sensor | 9. VDC OFF switch |
| 10. Rear wheel sensor | | |

JSFIA0529ZZ

EBD

[VDC/TCS/ABS]

< SYSTEM DESCRIPTION >

- A. Back of spiral cable assembly
- B. Combination meter
- C. Engine room (right side)
- D. Steering knuckle
- E. Under center console
- F. Instrument driver lower panel
- G. Rear axle

EXCEPT FOR USA

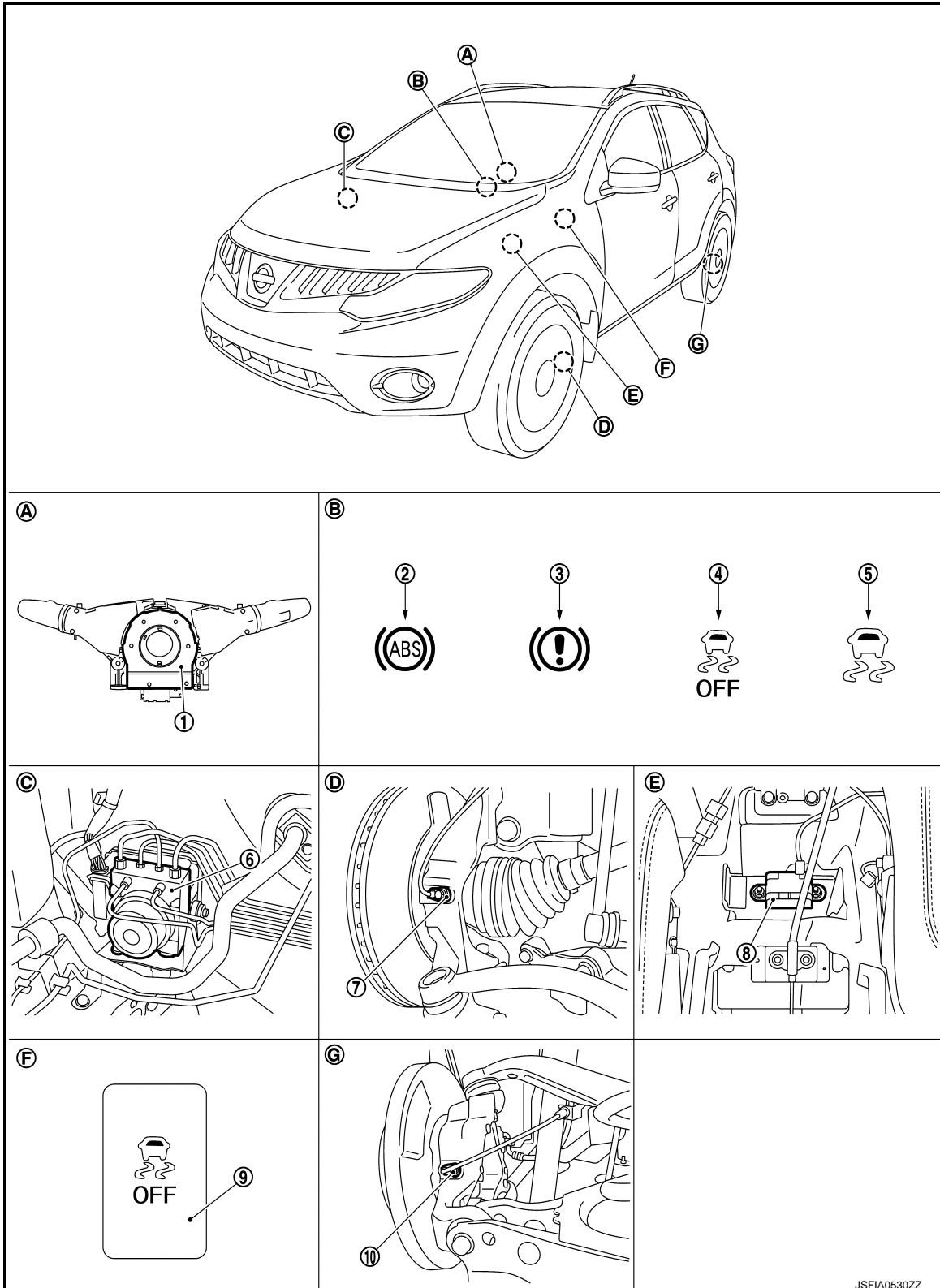

JSFIA0530ZZ

< SYSTEM DESCRIPTION >

- | | | | |
|----------------------------------|---------------------------------|--|---|
| 1. Steering angle sensor | 2. ABS warning lamp | 3. Brake warning lamp | A |
| 4. VDC OFF indicator lamp | 5. VDC warning lamp | 6. ABS actuator and electric unit (control unit) | |
| 7. Front wheel sensor | 8. Yaw rate/side/decel G sensor | 9. VDC OFF switch | B |
| 10. Rear wheel sensor | | | |
| A. Back of spiral cable assembly | B. Combination meter | C. Engine room (right side) | C |
| D. Steering knuckle | E. Under center console | F. Instrument driver lower panel | |
| G. Rear axle | | | |

Component Description

INFOID:000000008457254

Component parts		Reference
ABS actuator and electric unit (control unit)	Pump	BRC-45, "Description"
	Motor	
	Actuator relay (Main relay)	BRC-64, "Description"
	ABS IN valve	BRC-58, "Description"
	ABS OUT valve	BRC-60, "Description"
	Cut valve 1 (CV1), cut valve 2 (CV2)	BRC-81, "Description"
	Suction valve 1 (SV1), suction valve 2 (SV2)	BRC-83, "Description"
Wheel sensor	BRC-33, "Description"	
Yaw rate/side/decel G sensor	BRC-47, "Description"	
Steering angle sensor	BRC-68, "Description"	
VDC OFF switch	BRC-94, "Description"	
ABS warning lamp	BRC-96, "Description"	
Brake warning lamp	BRC-97, "Description"	
VDC warning lamp	BRC-99, "Description"	
VDC OFF indicator lamp	BRC-100, "Description"	

A
B
C
D
E
BRC
G
H
I
J
K
L
M
N
O
P

DIAGNOSIS SYSTEM [ABS ACTUATOR AND ELECTRIC UNIT (CONTROL UNIT)]

< SYSTEM DESCRIPTION >

[VDC/TCS/ABS]

DIAGNOSIS SYSTEM [ABS ACTUATOR AND ELECTRIC UNIT (CONTROL UNIT)]

CONSULT Function

INFOID:000000008457255

FUNCTION

CONSULT can display each diagnostic item using the diagnostic test modes as following.

Diagnostic test mode	Function
Work support	This mode enables a technician to adjust some devices faster and more accurately by following the indications on CONSULT.
Self diagnostic result	Self-diagnostic results can be read and erased quickly.
Data monitor	Input/Output data in the ABS actuator and electric unit (control unit) can be read.
Active test	CONSULT drives some actuators apart from the ABS actuator and electric unit (control unit) and also shifts some parameters in a specified range.
ECU identification	ABS actuator and electric unit (control unit) part number can be read.

WORK SUPPORT

Item	Description
ST ANGLE SENSOR ADJUSTMENT	Adjusts the neutral position of the steering angle sensor.
DECEL G SEN CALIBRATION (only AWD models)	Calibrates decel G sensor.

SELF DIAGNOSTIC RESULT

Operation Procedure

Before performing the self-diagnosis for "ABS" with CONSULT, start the engine and drive the vehicle at 30 km/h (19 MPH) or more for approximately 1 minute.

Display Item List

Refer to [BRC-107, "DTC No. Index"](#).

How to Erase Self-diagnosis Results

After erasing DTC memory for "ABS" with CONSULT, start the engine and drive the vehicle at 30 km/h (19 MPH) or more for approximately 1 minute as the final inspection, and make sure that the ABS warning lamp, VDC warning lamp and brake warning lamp turn OFF.

CAUTION:

If memory cannot be erased, perform applicable diagnosis.

NOTE:

- When the wheel sensor malfunctions, after inspecting the wheel sensor system, the ABS warning lamp, VDC warning lamp and brake warning lamp will not turn OFF even when the system is normal unless the vehicle is driving at approximately 30 km/h (19 MPH) or more for approximately 1 minute.
- Brake warning lamp will turn ON in case of parking brake operation (when switch is ON) or of brake fluid level switch operation (when brake fluid is insufficient).
- VDC OFF switch should not stay "ON" position.

DATA MONITOR

Display Item List

NOTE:

The following table includes information (items) inapplicable to this vehicle. For information (items) applicable to this vehicle, refer to CONSULT display items.

DIAGNOSIS SYSTEM [ABS ACTUATOR AND ELECTRIC UNIT (CONTROL UNIT)]

< SYSTEM DESCRIPTION >

[VDC/TCS/ABS]

×: Applicable ▼: Optional item

Monitor item (Unit)	SELECT MONITOR ITEM		Remarks	
	ECU INPUT SIGNALS	MAIN SIGNALS		
FR LH SENSOR [km/h (MPH)]	×	×	Wheel speed	A
FR RH SENSOR [km/h (MPH)]	×	×		B
RR LH SENSOR [km/h (MPH)]	×	×		C
RR RH SENSOR [km/h (MPH)]	×	×		D
STOP LAMP SW (On/Off)	×	×	Stop lamp switch signal status	E
BATTERY VOLT (V)	×	×	Battery voltage supplied to the ABS actuator and electric unit (control unit)	
GEAR	×	×	Gear position determined by TCM	BRC
R POSI SIG (On/Off)	▼	▼	Shift position judged by shift position (R) signal	
N POSI SIG (On/Off)	▼	▼	Shift position judged by shift position (N) signal	G
P POSI SIG (On/Off)	▼	▼	Shift position judged by shift position (P) signal	H
SLCT LVR POSI	×	×	Shift position judged by shift position signal	
OFF SW (On/Off)	×	×	VDC OFF switch	I
YAW RATE SEN (d/s)	×	×	Yaw rate detected by yaw rate/side/decel G sensor	
DECEL G-SEN (G)	×	×	Decel G detected by yaw rate/side/decel G sensor	J
ACCEL POS SIG (%)	×	▼	Throttle actuator opening/closing is displayed (Linked with accelerator pedal)	K
SIDE G-SENSOR (m/s ²)	×	▼	Transverse G detected by yaw rate/side/decel G sensor	
STR ANGLE SIG (°)	×	▼	Steering angle detected by steering angle sensor	L
ENGINE RPM [tr/min (rpm)]	×	▼	Engine speed	M
FLUID LEV SW (On/Off)	×	▼	Brake fluid level switch	
PRESS SENSOR (bar)	×	▼	Brake fluid pressure detected by pressure sensor	N
FR RH IN SOL (On/Off)	▼	×	Operation status of front RH ABS IN valve	O
FR RH OUT SOL (On/Off)	▼	×	Operation status of front RH ABS OUT valve	
FR LH IN SOL (On/Off)	▼	×	Operation status of front LH ABS IN valve	P
FR LH OUT SOL (On/Off)	▼	×	Operation status of front LH ABS OUT valve	
RR RH IN SOL (On/Off)	▼	×	Operation status of rear RH ABS IN valve	
RR RH OUT SOL (On/Off)	▼	×	Operation status of rear RH ABS OUT valve	

DIAGNOSIS SYSTEM [ABS ACTUATOR AND ELECTRIC UNIT (CONTROL UNIT)]

< SYSTEM DESCRIPTION >

[VDC/TCS/ABS]

Monitor item (Unit)	SELECT MONITOR ITEM		Remarks
	ECU INPUT SIGNALS	MAIN SIGNALS	
RR LH IN SOL (On/Off)	▼	×	Operation status of rear LH ABS IN valve
RR LH OUT SOL (On/Off)	▼	×	Operation status of rear LH ABS OUT valve
MOTOR RELAY (On/Off)	▼	×	Motor and motor relay operation
ACTUATOR RLY (On/Off)	▼	×	Actuator relay operation
ABS WARN LAMP (On/Off)	▼	×	ABS warning lamp
OFF LAMP (On/Off)	▼	×	VDC OFF indicator lamp
SLIP/VDC LAMP (On/Off)	▼	×	VDC warning lamp
CV1 (On/Off)	▼	▼	Cut valve 1 (CV1) monitor
CV2 (On/Off)	▼	▼	Cut valve 2 (CV2) monitor
SV1 (On/Off)	▼	▼	Suction valve 1 (SV1) monitor
SV2 (On/Off)	▼	▼	Suction valve 2 (SV2) monitor
EBD SIGNAL (On/Off)	▼	▼	EBD operation
ABS SIGNAL (On/Off)	▼	▼	ABS operation
TCS SIGNAL (On/Off)	▼	▼	TCS operation
VDC SIGNAL (On/Off)	▼	▼	VDC operation
EBD FAIL SIG (On/Off)	▼	▼	EBD fail-safe status
ABS FAIL SIG (On/Off)	▼	▼	ABS fail-safe status
TCS FAIL SIG (On/Off)	▼	▼	TCS fail-safe status
VDC FAIL SIG (On/Off)	▼	▼	VDC fail-safe status
EBD WARN LAMP (On/Off)	▼	▼	Brake warning lamp
CRANKING SIG (On/Off)	▼	▼	Crank operation
4WD FAIL REQ (On/Off)	▼	▼	AWD fail-safe signal status
2WD/4WD (2WD/4WD)	▼	▼	Distinguish 2WD and AWD

NOTE:

A brief moment of On/Off condition occurs every 20 seconds after ignition switch turned ON. This is not malfunction because it is a operation for checking.

ACTIVE TEST MODE

CAUTION:

DIAGNOSIS SYSTEM [ABS ACTUATOR AND ELECTRIC UNIT (CONTROL UNIT)]

< SYSTEM DESCRIPTION >

[VDC/TCS/ABS]

- **Never perform active test while driving vehicle.**
- **Make sure to completely bleed air from brake system.**
- **The active test cannot be started when ABS warning lamp, VDC warning lamp and brake warning lamp is ON.**
- **ABS warning lamp, VDC warning lamp and brake warning lamp are ON during active test.**

NOTE:

- When active test is performed while depressing the pedal, the pedal depression amount will change. This is normal.
- "TEST IS STOPPED" in "ABS" with CONSULT is displayed 10 seconds after operation start.
- After "TEST IS STOPPED" in "ABS" with CONSULT is displayed, to perform test again.

Test Item

ABS IN Valve and ABS OUT valve

- Select "Up", "Keep" and "Down" of "ACTIVE TEST" in "ABS" with CONSULT. Then use screen monitor to check that each valve operates as shown in the table below.

Test item	Display item	Display		
		Up	Keep	Down
FR RH SOL	FR RH IN SOL	Off	On	On
	FR RH OUT SOL	Off	Off	On*
FR LH SOL	FR LH IN SOL	Off	On	On
	FR LH OUT SOL	Off	Off	On*
RR RH SOL	RR RH IN SOL	Off	On	On
	RR RH OUT SOL	Off	Off	On*
RR LH SOL	RR LH IN SOL	Off	On	On
	RR LH OUT SOL	Off	Off	On*

BRC

G
H
I

J

K

L

M

N

O

P

*: On for 1 to 2 seconds after the select, and then Off.

NOTE:

A brief moment of On/Off condition occurs every 20 seconds after ignition switch turned ON. This is not malfunction because it is a operation for checking.

ABS IN Valve (ACT) and ABS OUT valve (ACT)

- Select "Up", "ACT UP" and "ACT KEEP" of "ACTIVE TEST" in "ABS" with CONSULT. Then use screen monitor to check that each valve operates as shown in the table below.

Test item	Display item	Display		
		Up	ACT UP	ACT KEEP
FR RH ABS SOLENOID (ACT)	FR RH IN SOL	Off	Off	Off
	FR RH OUT SOL	Off	Off	Off
	CV1	Off	On	On
	SV1	Off	On*	Off
FR LH ABS SOLENOID (ACT)	FR LH IN SOL	Off	Off	Off
	FR LH OUT SOL	Off	Off	Off
	CV2	Off	On	On
	SV2	Off	On*	Off
RR RH ABS SOLENOID (ACT)	RR RH IN SOL	Off	Off	Off
	RR RH OUT SOL	Off	Off	Off
	CV2	Off	On	On
	SV2	Off	On*	Off

DIAGNOSIS SYSTEM [ABS ACTUATOR AND ELECTRIC UNIT (CONTROL UNIT)]

< SYSTEM DESCRIPTION >

[VDC/TCS/ABS]

Test item	Display item	Display		
		Up	ACT UP	ACT KEEP
RR LH ABS SOLENOID (ACT)	RR LH IN SOL	Off	Off	Off
	RR LH OUT SOL	Off	Off	Off
	CV1	Off	On	On
	SV1	Off	On*	Off

*: On for 1 to 2 seconds after the select, and then Off.

NOTE:

A brief moment of On/Off condition occurs every 20 seconds after ignition switch turned ON. This is not malfunction because it is a operation for checking.

ABS MOTOR

- Select "On" and "Off" of "ACTIVE TEST" in "ABS" with CONSULT. Make sure motor relay and actuator relay operates as shown in table below.

Test item	Display item	Display	
		On	Off
ABS MOTOR	MOTOR RELAY	On	Off
	ACTUATOR RLY	On	On

NOTE:

A brief moment of On/Off condition occurs every 20 seconds after ignition switch turned ON. This is not malfunction because it is a operation for checking.

ECU IDENTIFICATION

ABS actuator and electric unit (control unit) part number can be read.

C1101, C1102, C1103, C1104 WHEEL SENSOR

< DTC/CIRCUIT DIAGNOSIS >

[VDC/TCS/ABS]

DTC/CIRCUIT DIAGNOSIS

C1101, C1102, C1103, C1104 WHEEL SENSOR

Description

INFOID:000000008457256

When the sensor rotor rotates, the magnetic field changes. It converts the magnetic field changes to current signals (rectangular wave) and transmits them to the ABS actuator and electric unit (control unit).

DTC Logic

INFOID:000000008457257

DTC DETECTION LOGIC

DTC	Display item	Malfunction detected condition	Possible cause
C1101	RR RH SENSOR-1	Circuit of rear RH wheel sensor is open or short circuit. Current signal from sensor is outside limits.	<ul style="list-style-type: none">• Harness or connector• Wheel sensor• ABS actuator and electric unit (control unit)
C1102	RR LH SENSOR-1	Circuit of rear LH wheel sensor is open or short circuit. Current signal from sensor is outside limits.	
C1103	FR RH SENSOR-1	Circuit of front RH wheel sensor is open or short circuit. Current signal from sensor is outside limits.	
C1104	FR LH SENSOR-1	Circuit of front LH wheel sensor is open or short circuit. Current signal from sensor is outside limits.	

DTC CONFIRMATION PROCEDURE

1. PRECONDITIONING

If "DTC CONFIRMATION PROCEDURE" has been previously conducted, always turn the ignition switch OFF and wait at least 10 seconds before conducting the next test.

>> GO TO 2.

2. DTC REPRODUCTION PROCEDURE

1. Start the engine and drive the vehicle at 30 km/h (19 MPH) or more for approximately 1 minute.
2. Perform self-diagnosis for "ABS" with CONSULT.

Is DTC "C1101", "C1102", "C1103" or "C1104" detected?

- YES >> Proceed to diagnosis procedure. Refer to [BRC-33, "Diagnosis Procedure"](#).
NO >> INSPECTION END

Diagnosis Procedure

INFOID:000000008457258

CAUTION:

Never check the between wheel sensor harness connector terminals.

1. CHECK WHEEL SENSOR

1. Turn the ignition switch OFF.
2. Check the wheel sensor for damage.

Is the inspection result normal?

- YES >> GO TO 3.
NO >> GO TO 2.

2. REPLACE WHEEL SENSOR (1)

1. Replace wheel sensor.
 - Front: Refer to [BRC-121, "FRONT WHEEL SENSOR : Exploded View"](#).
 - Rear: Refer to [BRC-122, "REAR WHEEL SENSOR : Exploded View"](#).
2. Erase self-diagnosis result for "ABS".
3. Turn the ignition switch OFF, and wait 10 seconds or more.
4. Start the engine.
5. Drive the vehicle at approx. 30 km/h (19 MPH) or more for approx. 1 minute.
6. Stop the vehicle.

C1101, C1102, C1103, C1104 WHEEL SENSOR

[VDC/TCS/ABS]

< DTC/CIRCUIT DIAGNOSIS >

7. Perform self-diagnosis for "ABS" with CONSULT.

Is DTC "C1101", "C1102", "C1103" or "C1104" detected?

YES >> GO TO 3.

NO >> INSPECTION END

3.CHECK CONNECTOR

1. Turn the ignition switch OFF.

2. Check the ABS actuator and electric unit (control unit) harness connector for disconnection or looseness.

3. Check the wheel sensor harness connector for disconnection or looseness.

Is the inspection result normal?

YES >> GO TO 5.

NO >> Repair or replace error-detected parts, securely lock the harness connector, and GO TO 4.

4.PERFORM SELF-DIAGNOSIS (1)

1. Erase self-diagnosis result for "ABS" with CONSULT.

2. Turn the ignition switch OFF, and wait 10 seconds or more.

3. Start the engine.

4. Drive the vehicle at approx. 30 km/h (19 MPH) or more for approx. 1 minute.

5. Stop the vehicle.

6. Perform self-diagnosis for "ABS" with CONSULT.

Is DTC "C1101", "C1102", "C1103" or "C1104" detected?

YES >> GO TO 5.

NO >> INSPECTION END

5.CHECK TERMINAL

1. Turn the ignition switch OFF.

2. Disconnect ABS actuator and electric unit (control unit) harness connector and then check the ABS actuator and electric unit (control unit) pin terminals for damage or loose connection with harness connector.

3. Disconnect wheel sensor harness connector and check the each wheel sensor pin terminals for damage or loose connection with harness connector.

Is the inspection result normal?

YES >> GO TO 7.

NO >> Repair or replace error-detected parts and GO TO 6.

6.PERFORM SELF-DIAGNOSIS (2)

1. Connect ABS actuator and electric unit (control unit) harness connector.

2. Connect wheel sensor harness connector.

3. Erase self-diagnosis result for "ABS".

4. Turn the ignition switch OFF, and wait 10 seconds or more.

5. Start the engine.

6. Drive the vehicle at approx. 30 km/h (19 MPH) or more for approx. 1 minute.

7. Stop the vehicle.

8. Perform self-diagnosis for "ABS" with CONSULT.

Is DTC "C1101", "C1102", "C1103" or "C1104" detected?

YES >> GO TO 7.

NO >> INSPECTION END

7.CHECK WHEEL SENSOR HARNESS

1. Turn the ignition switch OFF.

2. Disconnect ABS actuator and electric unit (control unit) harness connector.

3. Disconnect wheel sensor harness connector.

4. Check the continuity between ABS actuator and electric unit (control unit) harness connector and wheel sensor harness connector. (Check the continuity when steering wheel is steered to RH and LH, or center harness in wheel housing is moved.)

C1101, C1102, C1103, C1104 WHEEL SENSOR

< DTC/CIRCUIT DIAGNOSIS >

[VDC/TCS/ABS]

Measurement connector and terminal for power supply circuit

ABS actuator and electric unit (control unit)		Wheel sensor		Continuity
Connector	Terminal	Connector	Terminal	
E36	9	E22 (Front LH wheel)	1	Existed
	5	E39 (Front RH wheel)	3	
	3	C3 ^{*1} (Rear LH wheel) C5 ^{*2} (Rear LH wheel)	5	
	11	C4 ^{*1} (Rear RH wheel) C6 ^{*2} (Rear RH wheel)	7	

*1: 2WD

*2: AWD

Measurement connector and terminal for signal circuit

ABS actuator and electric unit (control unit)		Wheel sensor		Continuity
Connector	Terminal	Connector	Terminal	
E36	8	E22 (Front LH wheel)	2	Existed
	6	E39 (Front RH wheel)	4	
	2	C3 ^{*1} (Rear LH wheel) C5 ^{*2} (Rear LH wheel)	6	
	12	C4 ^{*1} (Rear RH wheel) C6 ^{*2} (Rear RH wheel)	8	

*1: 2WD

*2: AWD

Is the inspection result normal?

YES >> GO TO 9.

NO >> Repair or replace error-detected parts and GO TO 8.

8. PERFORM SELF-DIAGNOSIS (3)

1. Connect ABS actuator and electric unit (control unit) harness connector.
2. Connect wheel sensor harness connector.
3. Erase self-diagnosis result for "ABS".
4. Turn the ignition switch OFF, and wait 10 seconds or more.
5. Start the engine.
6. Drive the vehicle at approx. 30 km/h (19 MPH) or more for approx. 1 minute.
7. Stop the vehicle.
8. Perform self-diagnosis for "ABS" with CONSULT.

Is DTC "C1101", "C1102", "C1103" or "C1104" detected?

YES >> GO TO 9.

NO >> INSPECTION END

9. REPLACE WHEEL SENSOR (2)

1. Replace wheel sensor.
 - Front: Refer to [BRC-121, "FRONT WHEEL SENSOR : Exploded View"](#).
 - Rear: Refer to [BRC-122, "REAR WHEEL SENSOR : Exploded View"](#).
2. Erase self-diagnosis result for "ABS" with CONSULT.
3. Turn the ignition switch OFF, and wait 10 seconds or more.
4. Start the engine.
5. Drive the vehicle at approx. 30 km/h (19 MPH) or more for approx. 1 minute.
6. Stop the vehicle.
7. Perform self-diagnosis for "ABS" with CONSULT.

Is DTC "C1101", "C1102", "C1103" or "C1104" detected?

YES >> Replace ABS actuator and electric unit (control unit). Refer to [BRC-125, "Exploded View"](#).

NO >> INSPECTION END

C1101, C1102, C1103, C1104 WHEEL SENSOR

< DTC/CIRCUIT DIAGNOSIS >

[VDC/TCS/ABS]

Special Repair Requirement

INFOID:000000008457259

1. ADJUSTMENT OF STEERING ANGLE SENSOR NEUTRAL POSITION AND CALIBRATION OF DECEL G SENSOR

- After replacing an ABS actuator and electric unit (control unit), be sure to perform the following procedure.
- Adjustment of steering angle sensor neutral position: Refer to [BRC-9, "ADJUSTMENT OF STEERING ANGLE SENSOR NEUTRAL POSITION : Description"](#).
- Calibration of decel G sensor: Refer to [BRC-10, "CALIBRATION OF DECEL G SENSOR : Description"](#).
- After removing an ABS actuator and electric unit (control unit), be sure to perform the following procedure.
- Calibration of decel G sensor: Refer to [BRC-10, "CALIBRATION OF DECEL G SENSOR : Description"](#).
- After removing/replacing a steering angle sensor, be sure to perform the following procedure.
- Adjustment of steering angle sensor neutral position: Refer to [BRC-9, "ADJUSTMENT OF STEERING ANGLE SENSOR NEUTRAL POSITION : Description"](#).
- After removing/replacing a yaw rate/side/decel G sensor, be sure to perform the following procedure.
- Calibration of decel G sensor: Refer to [BRC-10, "CALIBRATION OF DECEL G SENSOR : Description"](#).

>> END

C1105, C1106, C1107, C1108 WHEEL SENSOR

< DTC/CIRCUIT DIAGNOSIS >

[VDC/TCS/ABS]

C1105, C1106, C1107, C1108 WHEEL SENSOR

Description

INFOID:000000008457260

When the sensor rotor rotates, the magnetic field changes. It converts the magnetic field changes to current signals (rectangular wave) and transmits them to the ABS actuator and electric unit (control unit).

DTC Logic

INFOID:000000008457261

DTC DETECTION LOGIC

DTC	Display item	Malfunction detected condition	Possible cause
C1105	RR RH SENSOR-2	Signal from rear RH wheel sensor does not match other 3 wheel speed signal.	<ul style="list-style-type: none">• Harness or connector• Wheel sensor• Sensor rotor• ABS actuator and electric unit (control unit)• Sensor rotor
C1106	RR LH SENSOR-2	Signal from rear LH wheel sensor does not match other 3 wheel speed signal.	
C1107	FR RH SENSOR-2	Signal from front RH wheel sensor does not match other 3 wheel speed signal.	
C1108	FR LH SENSOR-2	Signal from front LH wheel sensor does not match other 3 wheel speed signal.	

DTC CONFIRMATION PROCEDURE

1. PRECONDITIONING

If "DTC CONFIRMATION PROCEDURE" has been previously conducted, always turn the ignition switch OFF and wait at least 10 seconds before conducting the next test.

>> GO TO 2.

2. DTC REPRODUCTION PROCEDURE

1. Start the engine and drive the vehicle at 30 km/h (19 MPH) or more for approximately 1 minute.
2. Perform self-diagnosis for "ABS" with CONSULT.

Is DTC "C1105", "C1106", "C1107" or "C1108" detected?

- YES >> Proceed to diagnosis procedure. Refer to [BRC-37, "Diagnosis Procedure"](#).
NO >> INSPECTION END

Diagnosis Procedure

INFOID:000000008457262

CAUTION:

Never check the between wheel sensor harness connector terminals.

1. CHECK ABS ACTUATOR AND ELECTRIC UNIT (CONTROL UNIT) POWER SUPPLY SYSTEM

Check the ABS actuator and electric unit (control unit) power supply system. Refer to [BRC-89, "Diagnosis Procedure"](#).

Is the inspection result normal?

- YES >> GO TO 2.
NO >> Repair or replace error-detected parts.

2. CHECK TIRE

1. Turn the ignition switch OFF.
2. Check the tire air pressure, wear and size. Refer to [WT-49, "Tire Air Pressure"](#).

Is the inspection result normal?

- YES >> GO TO 5.
NO >> Adjust air pressure or replace tire and GO TO 3.

3. CHECK DATA MONITOR (1)

1. Erase self-diagnosis result for "ABS" with CONSULT.
2. Turn the ignition switch OFF, and wait 10 seconds or more.

C1105, C1106, C1107, C1108 WHEEL SENSOR

[VDC/TCS/ABS]

< DTC/CIRCUIT DIAGNOSIS >

3. Start the engine.
4. Select "ABS" and "DATA MONITOR", check the "FR LH SENSOR", "FR RH SENSOR", "RR LH SENSOR" and "RR RH SENSOR" with CONSULT.

NOTE:

Set the "DATA MONITOR" recording speed to "10 msec".

5. Read a value (wheel speed) of both normal wheel sensors and error-detecting wheel sensor.

Regarding the deference at 30 km/h (19 MPH) between the wheel speed detected by the error detecting wheel sensor and the maximum/minimum wheel speed detected by the normal wheel sensors, is the difference within 5%, respectively?

- YES >> GO TO 4.
NO >> GO TO 5.

4.PERFORM SELF-DIAGNOSIS (1)

1. Drive the vehicle at approx. 30 km/h (19 MPH) or more for approx. 1 minute.
2. Stop the vehicle.
3. Perform self-diagnosis for "ABS" with CONSULT.

Is DTC "C1105", "C1106", "C1107" or "C1108" detected?

- YES >> GO TO 5.
NO >> INSPECTION END

5.CHECK WHEEL SENSOR

1. Turn the ignition switch OFF.
2. Check the wheel sensor for damage.
3. Remove dust and foreign matter adhered to the sensor rotor with a vacuum dust collector through the wheel sensor mounting hole.

CAUTION:

Install wheel sensor with no backlash and float, and tighten the mounting bolt to the specified torque.

- Front: Refer to [BRC-121, "FRONT WHEEL SENSOR : Exploded View"](#).
- Rear: Refer to [BRC-122, "REAR WHEEL SENSOR : Exploded View"](#).

Is the inspection result normal?

- YES >> GO TO 8.
NO >> GO TO 6.

6.REPLACE WHEEL SENSOR (1)

1. Replace wheel sensor.
 - Front: Refer to [BRC-121, "FRONT WHEEL SENSOR : Exploded View"](#).
 - Rear: Refer to [BRC-122, "REAR WHEEL SENSOR : Exploded View"](#).
2. Erase self-diagnosis result for "ABS" with CONSULT.
3. Turn the ignition switch OFF, and wait 10 seconds or more.
4. Start the engine.
5. Select "ABS" and "DATA MONITOR", check the "FR LH SENSOR", "FR RH SENSOR", "RR LH SENSOR" and "RR RH SENSOR" with CONSULT.

NOTE:

Set the "DATA MONITOR" recording speed to "10 msec".

6. Read a value (wheel speed) of both normal wheel sensors and error-detecting wheel sensor.

Regarding the deference at 30 km/h (19 MPH) between the wheel speed detected by the error detecting wheel sensor and the maximum/minimum wheel speed detected by the normal wheel sensors, is the difference within 5%, respectively?

- YES >> GO TO 7.
NO >> GO TO 19.

7.PERFORM SELF-DIAGNOSIS (2)

 With CONSULT.

1. Drive the vehicle at approx. 30 km/h (19 MPH) or more for approx. 1 minute.
2. Stop the vehicle.
3. Perform self-diagnosis for "ABS" with CONSULT.

Is DTC "C1105", "C1106", "C1107" or "C1108" detected?

- YES >> GO TO 19.

C1105, C1106, C1107, C1108 WHEEL SENSOR

[VDC/TCS/ABS]

< DTC/CIRCUIT DIAGNOSIS >

NO >> INSPECTION END

8. CHECK CONNECTOR

1. Turn the ignition switch OFF.
2. Check the ABS actuator and electric unit (control unit) harness connector for disconnection or looseness.
3. Check the wheel sensor harness connector for disconnection or looseness.

Is the inspection result normal?

YES >> GO TO 11.

NO >> Repair or replace error-detected parts, securely lock the harness connector, and GO TO 9.

9. CHECK DATA MONITOR (2)

1. Erase self-diagnosis result for "ABS" with CONSULT.
2. Turn the ignition switch OFF, and wait 10 seconds or more.
3. Start the engine.
4. Select "ABS" and "DATA MONITOR", check the "FR LH SENSOR", "FR RH SENSOR", "RR LH SENSOR" and "RR RH SENSOR" with CONSULT.

NOTE:

Set the "DATA MONITOR" recording speed to "10 msec".

5. Read a value (wheel speed) of both normal wheel sensors and error-detecting wheel sensor.

Regarding the deference at 30 km/h (19 MPH) between the wheel speed detected by the error detecting wheel sensor and the maximum/minimum wheel speed detected by the normal wheel sensors, is the difference within 5%. respectively?

YES >> GO TO 10.

NO >> GO TO 11.

10. PERFORM SELF-DIAGNOSIS (3)

1. Drive the vehicle at approx. 30 km/h (19 MPH) or more for approx. 1 minute.
2. Stop the vehicle.
3. Perform self-diagnosis for "ABS" with CONSULT.

Is DTC "C1105", "C1106", "C1107" or "C1108" detected?

YES >> GO TO 11.

NO >> INSPECTION END

11. CHECK TERMINAL

1. Turn the ignition switch OFF.
2. Disconnect ABS actuator and electric unit (control unit) harness connector and then check the ABS actuator and electric unit (control unit) pin terminals for damage or loose connection with harness connector.
3. Disconnect wheel sensor harness connector and check the each wheel sensor pin terminals for damage or loose connection with harness connector.

Is the inspection result normal?

YES >> GO TO 14.

NO >> Repair or replace error-detected parts and GO TO 12.

12. CHECK DATA MONITOR (3)

1. Connect ABS actuator and electric unit (control unit) harness connector.
2. Connect wheel sensor harness connector.
3. Erase self-diagnosis result for "ABS" with CONSULT.
4. Turn the ignition switch OFF, and wait 10 seconds or more.
5. Start the engine.
6. Select "ABS" and "DATA MONITOR", check the "FR LH SENSOR", "FR RH SENSOR", "RR LH SENSOR" and "RR RH SENSOR" with CONSULT.

NOTE:

Set the "DATA MONITOR" recording speed to "10 msec".

7. Read a value (wheel speed) of both normal wheel sensors and error-detecting wheel sensor.

Regarding the deference at 30 km/h (19 MPH) between the wheel speed detected by the error detecting wheel sensor and the maximum/minimum wheel speed detected by the normal wheel sensors, is the difference within 5%. respectively?

YES >> GO TO 13.

NO >> GO TO 14.

A
B
C
D
E
BRC
G
H
I
J
K
L
M
N
O
P

C1105, C1106, C1107, C1108 WHEEL SENSOR

< DTC/CIRCUIT DIAGNOSIS >

[VDC/TCS/ABS]

13. PERFORM SELF-DIAGNOSIS (4)

1. Drive the vehicle at approx. 30 km/h (19 MPH) or more for approx. 1 minute.
2. Stop the vehicle.
3. Perform self-diagnosis for "ABS" with CONSULT.

Is DTC "C1105", "C1106", "C1107" or "C1108" detected?

YES >> GO TO 14.

NO >> INSPECTION END

14. CHECK WHEEL SENSOR HARNESS

1. Turn the ignition switch OFF.
2. Disconnect ABS actuator and electric unit (control unit) harness connector.
3. Disconnect wheel sensor harness connector.
4. Check the continuity between ABS actuator and electric unit (control unit) harness connector and the ground.

ABS actuator and electric unit (control unit)		—	Continuity
Connector	Terminal		
E36	9, 8	Ground	Not existed
	5, 6		
	3, 2		
	11, 12		

Is the inspection result normal?

YES >> GO TO 15.

NO >> Repair or replace error-detected parts and GO TO 15.

15. CHECK DATA MONITOR (4)

1. Connect ABS actuator and electric unit (control unit) harness connector.
2. Connect wheel sensor harness connector.
3. Erase self-diagnosis result for "ABS" with CONSULT.
4. Turn the ignition switch OFF, and wait 10 seconds or more.
5. Start the engine.
6. Select "ABS" and "DATA MONITOR", check the "FR LH SENSOR", "FR RH SENSOR", "RR LH SENSOR" and "RR RH SENSOR" with CONSULT.

NOTE:

Set the "DATA MONITOR" recording speed to "10 msec".

7. Read a value (wheel speed) of both normal wheel sensors and error-detecting wheel sensor.

Regarding the deference at 30 km/h (19 MPH) between the wheel speed detected by the error detecting wheel sensor and the maximum/minimum wheel speed detected by the normal wheel sensors, is the difference within 5%, respectively?

YES >> GO TO 16.

NO >> GO TO 17.

16. PERFORM SELF-DIAGNOSIS (5)

1. Drive the vehicle at approx. 30 km/h (19 MPH) or more for approx. 1 minute.
2. Stop the vehicle.
3. Perform self-diagnosis for "ABS" with CONSULT.

Is DTC "C1105", "C1106", "C1107" or "C1108" detected?

YES >> GO TO 17.

NO >> INSPECTION END

17. REPLACE WHEEL SENSOR (2)

1. Replace wheel sensor.
 - Front: Refer to [BRC-121, "FRONT WHEEL SENSOR : Exploded View"](#).
 - Rear: Refer to [BRC-122, "REAR WHEEL SENSOR : Exploded View"](#).
2. Erase self-diagnosis result for "ABS" with CONSULT.
3. Turn the ignition switch OFF, and wait 10 seconds or more.

C1105, C1106, C1107, C1108 WHEEL SENSOR

[VDC/TCS/ABS]

< DTC/CIRCUIT DIAGNOSIS >

4. Start the engine.
5. Select "ABS" and "DATA MONITOR", check the "FR LH SENSOR", "FR RH SENSOR", "RR LH SENSOR" and "RR RH SENSOR" with CONSULT.

NOTE:

Set the "DATA MONITOR" recording speed to "10 msec".

6. Read a value (wheel speed) of both normal wheel sensors and error-detecting wheel sensor.

Regarding the deference at 30 km/h (19 MPH) between the wheel speed detected by the error detecting wheel sensor and the maximum/minimum wheel speed detected by the normal wheel sensors, is the difference within 5%, respectively?

YES >> GO TO 18.

NO >> GO TO 19.

18.PERFORM SELF-DIAGNOSIS (6)

1. Drive the vehicle at approx. 30 km/h (19 MPH) or more for approx. 1 minute.
2. Stop the vehicle.
3. Perform self-diagnosis for "ABS" with CONSULT.

Is DTC "C1105", "C1106", "C1107" or "C1108" detected?

YES >> GO TO 19.

NO >> INSPECTION END

19.REPLACE SENSOR ROTOR

1. Replace sensor rotor.
 - Front: Refer to [BRC-124, "FRONT SENSOR ROTOR : Exploded View"](#).
 - Rear: Refer to [BRC-124, "REAR SENSOR ROTOR : Exploded View"](#).
2. Erase self-diagnosis result for "ABS" with CONSULT.
3. Turn the ignition switch OFF, and wait 10 seconds or more.
4. Start the engine.
5. Drive the vehicle at approx. 30 km/h (19 MPH) or more for approx. 1 minute.
6. Stop the vehicle.
7. Perform self-diagnosis for "ABS" with CONSULT.

Is DTC "C1105", "C1106", "C1107" or "C1108" detected?

YES >> Replace ABS actuator and electric unit (control unit). Refer to [BRC-125, "Exploded View"](#).

NO >> INSPECTION END

Special Repair Requirement

INFOID:000000008457263

1.ADJUSTMENT OF STEERING ANGLE SENSOR NEUTRAL POSITION AND CALIBRATION OF DECEL G SENSOR

- After replacing an ABS actuator and electric unit (control unit), be sure to perform the following procedure.
 - Adjustment of steering angle sensor neutral position: Refer to [BRC-9, "ADJUSTMENT OF STEERING ANGLE SENSOR NEUTRAL POSITION : Description"](#).
 - Calibration of decel G sensor: Refer to [BRC-10, "CALIBRATION OF DECEL G SENSOR : Description"](#).
- After removing an ABS actuator and electric unit (control unit), be sure to perform the following procedure.
 - Calibration of decel G sensor: Refer to [BRC-10, "CALIBRATION OF DECEL G SENSOR : Description"](#).
- After removing/replacing a steering angle sensor, be sure to perform the following procedure.
 - Adjustment of steering angle sensor neutral position: Refer to [BRC-9, "ADJUSTMENT OF STEERING ANGLE SENSOR NEUTRAL POSITION : Description"](#).
- After removing/replacing a yaw rate/side/decel G sensor, be sure to perform the following procedure.
 - Calibration of decel G sensor: Refer to [BRC-10, "CALIBRATION OF DECEL G SENSOR : Description"](#).

>> END

C1109 POWER AND GROUND SYSTEM

< DTC/CIRCUIT DIAGNOSIS >

[VDC/TCS/ABS]

C1109 POWER AND GROUND SYSTEM

Description

INFOID:000000008457264

Supplies electric power to the ABS actuator and electric unit (control unit).

DTC Logic

INFOID:000000008457265

DTC DETECTION LOGIC

DTC	Display item	Malfunction detected condition	Possible cause
C1109	BATTERY VOLTAGE [ABNORMAL]	When the ABS actuator and electric unit (control unit) power supply is lower than normal.	<ul style="list-style-type: none"> • Harness or connector • ABS actuator and electric unit (control unit) • Fuse

DTC CONFIRMATION PROCEDURE

1. PRECONDITIONING

If "DTC CONFIRMATION PROCEDURE" has been previously conducted, always turn the ignition switch OFF and wait at least 10 seconds before conducting the next test.

>> GO TO 2.

2. DTC REPRODUCTION PROCEDURE

1. Turn the ignition switch OFF to ON.
2. Perform self-diagnosis for "ABS" with CONSULT.

Is DTC "C1109" detected?

- YES >> Proceed to diagnosis procedure. Refer to [BRC-42, "Diagnosis Procedure"](#).
 NO >> INSPECTION END

Diagnosis Procedure

INFOID:000000008457266

1. CHECK CONNECTOR

1. Turn the ignition switch OFF.
2. Disconnect ABS actuator and electric unit (control unit) harness connector.
3. Check the terminal for deformation, disconnection, looseness, etc.

Is the inspection result normal?

- YES >> GO TO 2.
 NO >> Repair or replace error-detected parts.

2. CHECK ABS ACTUATOR AND ELECTRIC UNIT (CONTROL UNIT) POWER SUPPLY

1. Check the voltage between ABS actuator and electric unit (control unit) harness connector and ground.

ABS actuator and electric unit (control unit)		—	Voltage (Approx.)
Connector	Terminal		
E36	1	Ground	Battery voltage

2. Turn the ignition switch ON.

CAUTION:

Never start the engine.

3. Check the voltage between ABS actuator and electric unit (control unit) harness connector and ground.

ABS actuator and electric unit (control unit)		—	Voltage (Approx.)
Connector	Terminal		
E36	1	Ground	Battery voltage

Is the inspection result normal?

C1109 POWER AND GROUND SYSTEM

[VDC/TCS/ABS]

< DTC/CIRCUIT DIAGNOSIS >

- YES >> GO TO 4.
- NO >> GO TO 3.

3. CHECK ABS ACTUATOR AND ELECTRIC UNIT (CONTROL UNIT) POWER SUPPLY CIRCUIT

1. Turn the ignition switch OFF.
2. Check the 20A fusible link (#G).
3. Check the continuity and short circuit between ABS actuator and electric unit (control unit) harness connector terminal (1) and 20A fusible link (#G).

Is the inspection result normal?

- YES >> Perform trouble diagnosis for battery power supply. Refer to [PG-6, "Wiring Diagram - BATTERY POWER SUPPLY -"](#).
- NO >> Repair or replace error-detected parts.

4. CHECK ABS ACTUATOR AND ELECTRIC UNIT (CONTROL UNIT) GROUND CIRCUIT

1. Turn the ignition switch OFF.
2. Check the continuity between ABS actuator and electric unit (control unit) harness connector and ground.

ABS actuator and electric unit (control unit)		—	Continuity
Connector	Terminal		
E36	13	Ground	Existed
	26		

Is the inspection result normal?

- YES >> Replace ABS actuator and electric unit (control unit). Refer to [BRC-125, "Exploded View"](#).
- NO >> Repair or replace error-detected parts.

Special Repair Requirement

INFOID:000000008457267

1. ADJUSTMENT OF STEERING ANGLE SENSOR NEUTRAL POSITION AND CALIBRATION OF DECEL G SENSOR

- After replacing an ABS actuator and electric unit (control unit), be sure to perform the following procedure.
 - Adjustment of steering angle sensor neutral position: Refer to [BRC-9, "ADJUSTMENT OF STEERING ANGLE SENSOR NEUTRAL POSITION : Description"](#).
 - Calibration of decel G sensor: Refer to [BRC-10, "CALIBRATION OF DECEL G SENSOR : Description"](#).
- After removing an ABS actuator and electric unit (control unit), be sure to perform the following procedure.
 - Calibration of decel G sensor: Refer to [BRC-10, "CALIBRATION OF DECEL G SENSOR : Description"](#).
- After removing/replacing a steering angle sensor, be sure to perform the following procedure.
 - Adjustment of steering angle sensor neutral position: Refer to [BRC-9, "ADJUSTMENT OF STEERING ANGLE SENSOR NEUTRAL POSITION : Description"](#).
- After removing/replacing a yaw rate/side/decel G sensor, be sure to perform the following procedure.
 - Calibration of decel G sensor: Refer to [BRC-10, "CALIBRATION OF DECEL G SENSOR : Description"](#).

>> END

C1110 ABS ACTUATOR AND ELECTRIC UNIT (CONTROL UNIT)

< DTC/CIRCUIT DIAGNOSIS >

[VDC/TCS/ABS]

C1110 ABS ACTUATOR AND ELECTRIC UNIT (CONTROL UNIT)

Description

INFOID:000000008457268

ABS actuator and electric unit (control unit) is continuously monitoring ECU hardware and software for correct operation.

DTC Logic

INFOID:000000008457269

DTC DETECTION LOGIC

DTC	Display item	Malfunction detected condition	Possible cause
C1110	CONTROLLER FAILURE	When there is an internal malfunction in the ABS actuator and electric unit (control unit).	ABS actuator and electric unit (control unit)

DTC CONFIRMATION PROCEDURE

1. PRECONDITIONING

If "DTC CONFIRMATION PROCEDURE" has been previously conducted, always turn the ignition switch OFF and wait at least 10 seconds before conducting the next test.

>> GO TO 2.

2. DTC REPRODUCTION PROCEDURE

1. Turn the ignition switch OFF to ON.
2. Perform self-diagnosis for "ABS" with CONSULT.

Is DTC "C1110" detected?

- YES >> Proceed to diagnosis procedure. Refer to [BRC-44. "Diagnosis Procedure"](#).
NO >> INSPECTION END

Diagnosis Procedure

INFOID:000000008457270

1. REPLACE ABS ACTUATOR AND ELECTRIC UNIT (CONTROL UNIT)

Replace ABS actuator and electric unit (control unit) when self-diagnostic result shows items other than those applicable.

>> Replace ABS actuator and electric unit (control unit). Refer to [BRC-125. "Exploded View"](#).

Special Repair Requirement

INFOID:000000008457271

1. ADJUSTMENT OF STEERING ANGLE SENSOR NEUTRAL POSITION AND CALIBRATION OF DECEL G SENSOR

- After replacing an ABS actuator and electric unit (control unit), be sure to perform the following procedure.
- Adjustment of steering angle sensor neutral position: Refer to [BRC-9. "ADJUSTMENT OF STEERING ANGLE SENSOR NEUTRAL POSITION : Description"](#).
- Calibration of decel G sensor: Refer to [BRC-10. "CALIBRATION OF DECEL G SENSOR : Description"](#).
- After removing an ABS actuator and electric unit (control unit), be sure to perform the following procedure.
- Calibration of decel G sensor: Refer to [BRC-10. "CALIBRATION OF DECEL G SENSOR : Description"](#).
- After removing/replacing a steering angle sensor, be sure to perform the following procedure.
- Adjustment of steering angle sensor neutral position: Refer to [BRC-9. "ADJUSTMENT OF STEERING ANGLE SENSOR NEUTRAL POSITION : Description"](#).
- After removing/replacing a yaw rate/side/decel G sensor, be sure to perform the following procedure.
- Calibration of decel G sensor: Refer to [BRC-10. "CALIBRATION OF DECEL G SENSOR : Description"](#).

>> END

C1111 ABS MOTOR, MOTOR RELAY SYSTEM

< DTC/CIRCUIT DIAGNOSIS >

[VDC/TCS/ABS]

C1111 ABS MOTOR, MOTOR RELAY SYSTEM

Description

INFOID:000000008457272

PUMP

The pump returns the brake fluid stored in the reservoir to the master cylinder by reducing the pressure.

MOTOR

The motor drives the pump according to the signals transmitted by the ABS actuator and electric unit (control unit).

MOTOR RELAY

Activates or deactivates motor according to the signals transmitted by the ABS actuator and electric unit (control unit).

DTC Logic

INFOID:000000008457273

DTC DETECTION LOGIC

DTC	Display item	Malfunction detected condition	Possible cause
C1111	PUMP MOTOR	During the actuator motor operating with ON, when the actuator motor turns OFF, or when the control line for actuator motor relay is open.	<ul style="list-style-type: none"> • Harness or connector • ABS actuator and electric unit (control unit)
		During the actuator motor operating with OFF, when the actuator motor turns ON, or when the control line for relay is shorted to ground.	

DTC CONFIRMATION PROCEDURE

1. PRECONDITIONING

If "DTC CONFIRMATION PROCEDURE" has been previously conducted, always turn the ignition switch OFF and wait at least 10 seconds before conducting the next test.

>> GO TO 2.

2. DTC REPRODUCTION PROCEDURE

1. Turn the ignition switch OFF to ON.
2. Perform self-diagnosis for "ABS" with CONSULT.

Is DTC "C1111" detected?

- YES >> Proceed to diagnosis procedure. Refer to [BRC-45, "Diagnosis Procedure"](#).
- NO >> INSPECTION END

Diagnosis Procedure

INFOID:000000008457274

1. CHECK CONNECTOR

1. Turn the ignition switch OFF.
2. Disconnect ABS actuator and electric unit (control unit) harness connector.
3. Check the terminal for deformation, disconnect, looseness, etc.

Is the inspection result normal?

- YES >> GO TO 2.
- NO >> Repair or replace error-detected parts.

2. CHECK ABS MOTOR AND MOTOR RELAY POWER SUPPLY

1. Check the voltage between ABS actuator and electric unit (control unit) harness connector and ground.

ABS actuator and electric unit (control unit)		—	Voltage (Approx.)
Connector	Terminal		
E36	14	Ground	Battery voltage

C1111 ABS MOTOR, MOTOR RELAY SYSTEM

[VDC/TCS/ABS]

< DTC/CIRCUIT DIAGNOSIS >

2. Turn the ignition switch ON.

CAUTION:

Never start the engine.

3. Check the voltage between ABS actuator and electric unit (control unit) harness connector and ground.

ABS actuator and electric unit (control unit)		—	Voltage (Approx.)
Connector	Terminal		
E36	14	Ground	Battery voltage

Is the inspection result normal?

YES >> GO TO 4.

NO >> GO TO 3.

3. CHECK ABS MOTOR AND MOTOR RELAY POWER SUPPLY CIRCUIT

1. Turn the ignition switch OFF.

2. Check the 30A fusible link (#F).

3. Check the continuity and short circuit between ABS actuator and electric unit (control unit) harness connector terminal (14) and 30A fusible link (#F).

Is the inspection result normal?

YES >> Perform trouble diagnosis for battery power supply. Refer to [PG-6. "Wiring Diagram - BATTERY POWER SUPPLY -"](#).

NO >> Repair or replace error-detected parts.

4. CHECK ABS MOTOR AND MOTOR RELAY GROUND CIRCUIT

Check the continuity between ABS actuator and electric unit (control unit) harness connector and ground.

ABS actuator and electric unit (control unit)		—	Continuity
Connector	Terminal		
E36	13	Ground	Existed
	26		

Is the inspection result normal?

YES >> Replace ABS actuator and electric unit (control unit). Refer to [BRC-125. "Exploded View"](#).

NO >> Repair or replace error-detected parts.

Special Repair Requirement

INFOID:000000008457275

1. ADJUSTMENT OF STEERING ANGLE SENSOR NEUTRAL POSITION AND CALIBRATION OF DECEL G SENSOR

- After replacing an ABS actuator and electric unit (control unit), be sure to perform the following procedure.
 - Adjustment of steering angle sensor neutral position: Refer to [BRC-9. "ADJUSTMENT OF STEERING ANGLE SENSOR NEUTRAL POSITION : Description"](#).
 - Calibration of decel G sensor: Refer to [BRC-10. "CALIBRATION OF DECEL G SENSOR : Description"](#).
- After removing an ABS actuator and electric unit (control unit), be sure to perform the following procedure.
 - Calibration of decel G sensor: Refer to [BRC-10. "CALIBRATION OF DECEL G SENSOR : Description"](#).
- After removing/replacing a steering angle sensor, be sure to perform the following procedure.
 - Adjustment of steering angle sensor neutral position: Refer to [BRC-9. "ADJUSTMENT OF STEERING ANGLE SENSOR NEUTRAL POSITION : Description"](#).
- After removing/replacing a yaw rate/side/decel G sensor, be sure to perform the following procedure.
 - Calibration of decel G sensor: Refer to [BRC-10. "CALIBRATION OF DECEL G SENSOR : Description"](#).

>> END

C1113, C1145, C1146 YAW RATE/SIDE/DECCEL G SENSOR

< DTC/CIRCUIT DIAGNOSIS >

[VDC/TCS/ABS]

C1113, C1145, C1146 YAW RATE/SIDE/DECCEL G SENSOR

Description

INFOID:000000008457276

Yaw rate/side/deccl G sensor detects yaw rate/side/deccl G affecting the vehicle, and transmits the data to the ABS actuator and electric unit (control unit) as an analog voltage signal.

DTC Logic

INFOID:000000008457277

DTC DETECTION LOGIC

DTC	Display item	Malfunction detected condition	Possible cause
C1113	G SENSOR	Decel G sensor is malfunctioning.	• Harness or connector • ABS actuator and electric unit (control unit) • Yaw rate/side/deccl G sensor
C1145	YAW RATE SENSOR	<ul style="list-style-type: none">• Yaw rate sensor is malfunctioning.• Yaw rate/side/deccl G sensor power voltage is outside the standard.• Yaw rate/side/deccl G sensor signal line is open or shorted.	
C1146	SIDE G-SEN CIRCUIT	Side G sensor is malfunctioning.	

DTC CONFIRMATION PROCEDURE

1. PRECONDITIONING

If "DTC CONFIRMATION PROCEDURE" has been previously conducted, always turn the ignition switch OFF and wait at least 10 seconds before conducting the next test.

>> GO TO 2.

2. DTC REPRODUCTION PROCEDURE

1. Turn the ignition switch OFF to ON.
2. Perform self-diagnosis for "ABS" with CONSULT.

Is DTC "C1113", "C1145" or "C1146" detected?

- YES >> Proceed to diagnosis procedure. Refer to [BRC-47, "Diagnosis Procedure"](#).
NO >> INSPECTION END

Diagnosis Procedure

INFOID:000000008457278

CAUTION:

- Sudden turns (such as spin turns, acceleration turns), drifting, etc. may cause yaw rate/side/deccl G sensor circuit indicate a malfunction. However this is not a malfunction if normal operation can be resumed after restarting engine.
- When on a turntable, such as at a parking structure entrance, or when on a moving object with engine running, the VDC warning lamp might turn ON and self-diagnosis using the CONSULT yaw rate sensor system malfunction might be displayed, but in this case there is no malfunction with yaw rate/side/deccl G sensor circuit. As soon as the vehicle leaves the turntable or moving object, restart the engine to return the system to normal.

1. CHECK CONNECTOR

1. Turn the ignition switch OFF.
2. Disconnect ABS actuator and electric unit (control unit) harness connector.
3. Disconnect yaw rate/side/deccl G sensor harness connector.
4. Check the terminal for deformation, disconnection, looseness, etc.

Is the inspection result normal?

- YES >> GO TO 2.
NO >> Repair or replace error-detected parts.

2. CHECK YAW RATE/SIDE/DECCEL G SENSOR POWER SUPPLY CIRCUIT

1. Connect ABS actuator and electric unit (control unit) harness connector.
2. Turn the ignition switch ON.

C1113, C1145, C1146 YAW RATE/SIDE/DECEL G SENSOR

< DTC/CIRCUIT DIAGNOSIS >

[VDC/TCS/ABS]

CAUTION:

Never start the engine.

3. Check the voltage between yaw rate/side/decel G sensor harness connector and ground.

Yaw rate/side/decel G sensor		—	Voltage (Approx.)
Connector	Terminal		
M52	4	Ground	Battery voltage

4. Turn the ignition switch OFF.
5. Check the voltage between yaw rate/side/decel G sensor harness connector and ground.

Yaw rate/side/decel G sensor		—	Voltage (Approx.)
Connector	Terminal		
M52	4	Ground	0 V

Is the inspection result normal?

- YES >> GO TO 3.
NO >> Repair or replace error-detected parts.

3.CHECK YAW RATE/SIDE/DECEL G SENSOR GROUND CIRCUIT

Check the continuity between yaw rate/side/decel G sensor harness connector and ground.

Yaw rate/side/decel G sensor		—	Continuity
Connector	Terminal		
M52	1	Ground	Existed

Is the inspection result normal?

- YES >> GO TO 4.
NO >> Repair or replace error-detected parts.

4.CHECK YAW RATE/SIDE/DECEL G SENSOR HARNESS

1. Disconnect ABS actuator and electric unit (control unit) harness connector.
2. Check the continuity between yaw rate/side/decel G sensor harness connector and ABS actuator and electric unit (control unit) harness connector.

ABS actuator and electric unit (control unit)		Yaw rate/side/decel G sensor		Continuity
Connector	Terminal	Connector	Terminal	
E36	25	M52	2	Existed
	19		3	

Is the inspection result normal?

- YES >> GO TO 5.
NO >> Repair or replace error-detected parts.

5.CHECK DATA MONITOR

1. Connect yaw rate/side/decel G sensor harness connector.
2. Connect ABS actuator and electric unit (control unit) harness connector.
3. Select "ABS" and "DATA MONITOR" in order with CONSULT, select "YAW RATE SEN", "SIDE G-SEN" and "DECEL G-SEN", and check the yaw rate/side/decel G sensor signal.

Is the inspection result normal?

- YES >> Replace ABS actuator and electric unit (control unit). Refer to [BRC-125. "Exploded View"](#).
NO >> Replace yaw rate/side/decel G sensor. Refer to [BRC-127. "Exploded View"](#).

Special Repair Requirement

INFOID:000000008457279

1.AJUSTMENT OF STEERING ANGLE SENSOR NEUTRAL POSITION AND CALIBRATION OF DECEL G SENSOR

C1113, C1145, C1146 YAW RATE/SIDE/DECEL G SENSOR

< DTC/CIRCUIT DIAGNOSIS >

[VDC/TCS/ABS]

- After replacing an ABS actuator and electric unit (control unit), be sure to perform the following procedure.
- Adjustment of steering angle sensor neutral position: Refer to [BRC-9, "ADJUSTMENT OF STEERING ANGLE SENSOR NEUTRAL POSITION : Description"](#).
- Calibration of decel G sensor: Refer to [BRC-10, "CALIBRATION OF DECEL G SENSOR : Description"](#).
- After removing an ABS actuator and electric unit (control unit), be sure to perform the following procedure.
- Calibration of decel G sensor: Refer to [BRC-10, "CALIBRATION OF DECEL G SENSOR : Description"](#).
- After removing/replacing a steering angle sensor, be sure to perform the following procedure.
- Adjustment of steering angle sensor neutral position: Refer to [BRC-9, "ADJUSTMENT OF STEERING ANGLE SENSOR NEUTRAL POSITION : Description"](#).
- After removing/replacing a yaw rate/side/decel G sensor, be sure to perform the following procedure.
- Calibration of decel G sensor: Refer to [BRC-10, "CALIBRATION OF DECEL G SENSOR : Description"](#).

>> END

A
B
C
D
E
G
H
I
J
K
L
M
N
O
P

BRC

C1115 WHEEL SENSOR

Description

INFOID:000000008457280

When the sensor rotor rotates, the magnetic field changes. It converts the magnetic field changes to current signals (rectangular wave) and transmits them to the ABS actuator and electric unit (control unit).

DTC Logic

INFOID:000000008457281

DTC DETECTION LOGIC

DTC	Display item	Malfunction detected condition	Possible cause
C1115	ABS SENSOR [ABNORMAL SIGNAL]	When wheel sensor input signal is malfunctioning.	<ul style="list-style-type: none"> Harness or connector Wheel sensor ABS actuator and electric unit (control unit) Sensor rotor

DTC CONFIRMATION PROCEDURE

1. PRECONDITIONING

If "DTC CONFIRMATION PROCEDURE" has been previously conducted, always turn the ignition switch OFF and wait at least 10 seconds before conducting the next test.

>> GO TO 2.

2. DTC REPRODUCTION PROCEDURE

1. Start the engine and drive the vehicle at 30 km/h (19 MPH) or more for approximately 1 minute.
2. Perform self-diagnosis for "ABS" with CONSULT.

Is DTC "C1115" detected?

- YES >> Proceed to diagnosis procedure. Refer to [BRC-50, "Diagnosis Procedure"](#).
 NO >> INSPECTION END

Diagnosis Procedure

INFOID:000000008457282

CAUTION:

Never check the between wheel sensor harness connector terminals.

1. CHECK ABS ACTUATOR AND ELECTRIC UNIT (CONTROL UNIT) POWER SUPPLY SYSTEM

Check the ABS actuator and electric unit (control unit) power supply system. Refer to [BRC-89, "Diagnosis Procedure"](#).

Is the inspection result normal?

- YES >> GO TO 2.
 NO >> Repair or replace error-detected parts.

2. CHECK TIRE

1. Turn the ignition switch OFF.
2. Check the tire air pressure, wear and size. Refer to [WT-49, "Tire Air Pressure"](#).

Is the inspection result normal?

- YES >> GO TO 5.
 NO >> Adjust air pressure or replace tire and GO TO 3.

3. CHECK DATA MONITOR (1)

1. Erase self-diagnosis result for "ABS" with CONSULT.
2. Turn the ignition switch OFF, and wait 10 seconds or more.
3. Start the engine.
4. Select "ABS" and "DATA MONITOR", check the "FR LH SENSOR", "FR RH SENSOR", "RR LH SENSOR" and "RR RH SENSOR" with CONSULT.

NOTE:

C1115 WHEEL SENSOR

[VDC/TCS/ABS]

< DTC/CIRCUIT DIAGNOSIS >

Set the "DATA MONITOR" recording speed to "10 msec".

5. Read a value (wheel speed) of both normal wheel sensors and error-detecting wheel sensor.

Regarding the deference at 30 km/h (19 MPH) between the wheel speed detected by the error detecting wheel sensor and the maximum/minimum wheel speed detected by the normal wheel sensors, is the difference within 5%, respectively?

YES >> GO TO 4.

NO >> GO TO 5.

4.PERFORM SELF-DIAGNOSIS (1)

1. Drive the vehicle at approx. 30 km/h (19 MPH) or more for approx. 1 minute.
2. Stop the vehicle.
3. Perform self-diagnosis for "ABS" with CONSULT.

Is DTC "C1115" detected?

YES >> GO TO 5.

NO >> INSPECTION END

5.CHECK WHEEL SENSOR

1. Turn the ignition switch OFF.
2. Check the wheel sensor for damage.
3. Remove dust and foreign matter adhered to the sensor rotor with a vacuum dust collector through the wheel sensor mounting hole.

CAUTION:

Install wheel sensor with no backlash and float, and tighten the mounting bolt to the specified torque.

• **Front:** Refer to [BRC-121, "FRONT WHEEL SENSOR : Exploded View"](#).

• **Rear:** Refer to [BRC-122, "REAR WHEEL SENSOR : Exploded View"](#).

Is the inspection result normal?

YES >> GO TO 8.

NO >> GO TO 6.

6.REPLACE WHEEL SENSOR (1)

1. Replace wheel sensor.
 - Front: Refer to [BRC-121, "FRONT WHEEL SENSOR : Exploded View"](#).
 - Rear: Refer to [BRC-122, "REAR WHEEL SENSOR : Exploded View"](#).
2. Erase self-diagnosis result for "ABS" with CONSULT.
3. Turn the ignition switch OFF, and wait 10 seconds or more.
4. Start the engine.
5. Select "ABS" and "DATA MONITOR", check the "FR LH SENSOR", "FR RH SENSOR", "RR LH SENSOR" and "RR RH SENSOR" with CONSULT.

NOTE:

Set the "DATA MONITOR" recording speed to "10 msec".

6. Read a value (wheel speed) of both normal wheel sensors and error-detecting wheel sensor.

Regarding the deference at 30 km/h (19 MPH) between the wheel speed detected by the error detecting wheel sensor and the maximum/minimum wheel speed detected by the normal wheel sensors, is the difference within 5%, respectively?

YES >> GO TO 7.

NO >> GO TO 19.

7.PERFORM SELF-DIAGNOSIS (2)

1. Drive the vehicle at approx. 30 km/h (19 MPH) or more for approx. 1 minute.
2. Stop the vehicle.
3. Perform self-diagnosis for "ABS" with CONSULT.

Is DTC "C1115" detected?

YES >> GO TO 19.

NO >> INSPECTION END

8.CHECK CONNECTOR

1. Turn the ignition switch OFF.
2. Check the ABS actuator and electric unit (control unit) harness connector for disconnection or looseness.

C1115 WHEEL SENSOR

[VDC/TCS/ABS]

< DTC/CIRCUIT DIAGNOSIS >

3. Check the wheel sensor harness connector for disconnection or looseness.

Is the inspection result normal?

YES >> GO TO 11.

NO >> Repair or replace error-detected parts, securely lock the harness connector, and GO TO 9.

9.CHECK DATA MONITOR (2)

1. Erase self-diagnosis result for "ABS" with CONSULT.

2. Turn the ignition switch OFF, and wait 10 seconds or more.

3. Start the engine.

4. Select "ABS" and "DATA MONITOR", check the "FR LH SENSOR", "FR RH SENSOR", "RR LH SENSOR" and "RR RH SENSOR" with CONSULT.

NOTE:

Set the "DATA MONITOR" recording speed to "10 msec".

5. Read a value (wheel speed) of both normal wheel sensors and error-detecting wheel sensor.

Regarding the deference at 30 km/h (19 MPH) between the wheel speed detected by the error detecting wheel sensor and the maximum/minimum wheel speed detected by the normal wheel sensors, is the difference within 5%. respectively?

YES >> GO TO 10.

NO >> GO TO 11.

10.PERFORM SELF-DIAGNOSIS (3)

1. Drive the vehicle at approx. 30 km/h (19 MPH) or more for approx. 1 minute.

2. Stop the vehicle.

3. Perform self-diagnosis for "ABS" with CONSULT.

Is DTC "C1115" detected?

YES >> GO TO 11.

NO >> INSPECTION END

11.CHECK TERMINAL

1. Turn the ignition switch OFF.

2. Disconnect ABS actuator and electric unit (control unit) harness connector and then check the ABS actuator and electric unit (control unit) pin terminals for damage or loose connection with harness connector.

3. Disconnect wheel sensor harness connector and check the each wheel sensor pin terminals for damage or loose connection with harness connector.

Is the inspection result normal?

YES >> GO TO 14.

NO >> Repair or replace error-detected parts and GO TO 12.

12.CHECK DATA MONITOR (3)

1. Connect ABS actuator and electric unit (control unit) harness connector.

2. Connect wheel sensor harness connector.

3. Erase self-diagnosis result for "ABS" with CONSULT.

4. Turn the ignition switch OFF, and wait 10 seconds or more.

5. Start the engine.

6. Select "ABS" and "DATA MONITOR", check the "FR LH SENSOR", "FR RH SENSOR", "RR LH SENSOR" and "RR RH SENSOR" with CONSULT.

NOTE:

Set the "DATA MONITOR" recording speed to "10 msec".

7. Read a value (wheel speed) of both normal wheel sensors and error-detecting wheel sensor.

Regarding the deference at 30 km/h (19 MPH) between the wheel speed detected by the error detecting wheel sensor and the maximum/minimum wheel speed detected by the normal wheel sensors, is the difference within 5%. respectively?

YES >> GO TO 13.

NO >> GO TO 14.

13.PERFORM SELF-DIAGNOSIS (4)

1. Drive the vehicle at approx. 30 km/h (19 MPH) or more for approx. 1 minute.

2. Stop the vehicle.

3. Perform self-diagnosis for "ABS" with CONSULT.

C1115 WHEEL SENSOR

[VDC/TCS/ABS]

< DTC/CIRCUIT DIAGNOSIS >

Is DTC "C1115" detected?

YES >> GO TO 14.

NO >> INSPECTION END

14. CHECK WHEEL SENSOR HARNESS

1. Turn the ignition switch OFF.
2. Disconnect ABS actuator and electric unit (control unit) harness connector.
3. Disconnect wheel sensor harness connector.
4. Check the continuity between ABS actuator and electric unit (control unit) harness connector and wheel sensor harness connector. (Check the continuity when steering wheel is steered to RH and LH, or center harness in wheel housing is moved.)

Measurement connector and terminal for power supply circuit

ABS actuator and electric unit (control unit)		Wheel sensor		Continuity
Connector	Terminal	Connector	Terminal	
E36	9	E22 (Front LH wheel)	1	Existed
	5	E39 (Front RH wheel)	3	
	3	C3* ¹ (Rear LH wheel) C5* ² (Rear LH wheel)	5	
	11	C4* ¹ (Rear RH wheel) C6* ² (Rear RH wheel)	7	

*1: 2WD

*2: AWD

Measurement connector and terminal for signal circuit

ABS actuator and electric unit (control unit)		Wheel sensor		Continuity
Connector	Terminal	Connector	Terminal	
E36	8	E22 (Front LH wheel)	2	Existed
	6	E39 (Front RH wheel)	4	
	2	C3* ¹ (Rear LH wheel) C5* ² (Rear LH wheel)	6	
	12	C4* ¹ (Rear RH wheel) C6* ² (Rear RH wheel)	8	

*1: 2WD

*2: AWD

5. Check the continuity between ABS actuator and electric unit (control unit) harness connector and the ground.

ABS actuator and electric unit (control unit)		—	Continuity
Connector	Terminal		
E36	9, 8	Ground	Not existed
	5, 6		
	3, 2		
	11, 12		

Is the inspection result normal?

YES >> GO TO 15.

NO >> Repair or replace error-detected parts and GO TO 15.

15. CHECK DATA MONITOR (4)

1. Connect ABS actuator and electric unit (control unit) harness connector.
2. Connect wheel sensor harness connector.
3. Erase self-diagnosis result for "ABS" with CONSULT.
4. Turn the ignition switch OFF, and wait 10 seconds or more.

C1115 WHEEL SENSOR

[VDC/TCS/ABS]

< DTC/CIRCUIT DIAGNOSIS >

5. Start the engine.
6. Select "ABS" and "DATA MONITOR", check the "FR LH SENSOR", "FR RH SENSOR", "RR LH SENSOR" and "RR RH SENSOR" with CONSULT.

NOTE:

Set the "DATA MONITOR" recording speed to "10 msec".

7. Read a value (wheel speed) of both normal wheel sensors and error-detecting wheel sensor.

Regarding the deference at 30 km/h (19 MPH) between the wheel speed detected by the error detecting wheel sensor and the maximum/minimum wheel speed detected by the normal wheel sensors, is the difference within 5%, respectively?

YES >> GO TO 16.

NO >> GO TO 17.

16.PERFORM SELF-DIAGNOSIS (5)

1. Drive the vehicle at approx. 30 km/h (19 MPH) or more for approx. 1 minute.
2. Stop the vehicle.
3. Perform self-diagnosis for "ABS" with CONSULT.

Is DTC "C1115" detected?

YES >> GO TO 17.

NO >> INSPECTION END

17.REPLACE WHEEL SENSOR (2)

1. Replace wheel sensor.
 - Front: Refer to [BRC-121, "FRONT WHEEL SENSOR : Exploded View"](#).
 - Rear: Refer to [BRC-122, "REAR WHEEL SENSOR : Exploded View"](#).
2. Erase self-diagnosis result for "ABS" with CONSULT.
3. Turn the ignition switch OFF, and wait 10 seconds or more.
4. Start the engine.
5. Select "ABS" and "DATA MONITOR", check the "FR LH SENSOR", "FR RH SENSOR", "RR LH SENSOR" and "RR RH SENSOR" with CONSULT.

NOTE:

Set the "DATA MONITOR" recording speed to "10 msec".

6. Read a value (wheel speed) of both normal wheel sensors and error-detecting wheel sensor.

Regarding the deference at 30 km/h (19 MPH) between the wheel speed detected by the error detecting wheel sensor and the maximum/minimum wheel speed detected by the normal wheel sensors, is the difference within 5%, respectively?

YES >> GO TO 18.

NO >> GO TO 19.

18.PERFORM SELF-DIAGNOSIS (6)

1. Drive the vehicle at approx. 30 km/h (19 MPH) or more for approx. 1 minute.
2. Stop the vehicle.
3. Perform self-diagnosis for "ABS" with CONSULT.

Is DTC "C1115" detected?

YES >> GO TO 19.

NO >> INSPECTION END

19.REPLACE SENSOR ROTOR

1. Replace sensor rotor.
 - Front: Refer to [BRC-124, "FRONT SENSOR ROTOR : Exploded View"](#).
 - Rear: Refer to [BRC-124, "REAR SENSOR ROTOR : Exploded View"](#).
2. Erase self-diagnosis result for "ABS".
3. Turn the ignition switch OFF, and wait 10 seconds or more.
4. Start the engine.
5. Drive the vehicle at approx. 30 km/h (19 MPH) or more for approx. 1 minute.
6. Stop the vehicle.
7. Perform self-diagnosis for "ABS" with CONSULT.

Is DTC "C1115" detected?

YES >> Replace ABS actuator and electric unit (control unit). Refer to [BRC-125, "Exploded View"](#).

NO >> INSPECTION END

Special Repair Requirement

INFOID:000000008457283

1. ADJUSTMENT OF STEERING ANGLE SENSOR NEUTRAL POSITION AND CALIBRATION OF DECEL G SENSOR

- After replacing an ABS actuator and electric unit (control unit), be sure to perform the following procedure.
- Adjustment of steering angle sensor neutral position: Refer to [BRC-9, "ADJUSTMENT OF STEERING ANGLE SENSOR NEUTRAL POSITION : Description"](#).
- Calibration of decel G sensor: Refer to [BRC-10, "CALIBRATION OF DECEL G SENSOR : Description"](#).
- After removing an ABS actuator and electric unit (control unit), be sure to perform the following procedure.
- Calibration of decel G sensor: Refer to [BRC-10, "CALIBRATION OF DECEL G SENSOR : Description"](#).
- After removing/replacing a steering angle sensor, be sure to perform the following procedure.
- Adjustment of steering angle sensor neutral position: Refer to [BRC-9, "ADJUSTMENT OF STEERING ANGLE SENSOR NEUTRAL POSITION : Description"](#).
- After removing/replacing a yaw rate/side/decel G sensor, be sure to perform the following procedure.
- Calibration of decel G sensor: Refer to [BRC-10, "CALIBRATION OF DECEL G SENSOR : Description"](#).

>> END

A
B
C
D
E
G
H
I
J
K
L
M
N
O
P

BRC

C1116 STOP LAMP SWITCH

< DTC/CIRCUIT DIAGNOSIS >

[VDC/TCS/ABS]

C1116 STOP LAMP SWITCH

Description

INFOID:000000008457284

The stop lamp switch transmits the stop lamp switch signal (ON/OFF) to the ABS actuator and electric unit (control unit).

DTC Logic

INFOID:000000008457285

DTC DETECTION LOGIC

DTC	Display item	Malfunction detected condition	Possible cause
C1116	STOP LAMP SW	When a stop lamp switch signal is not input where the brake pedal is depressed.	<ul style="list-style-type: none">• Harness or connector• Stop lamp switch• ABS actuator and electric unit (control unit)

DTC CONFIRMATION PROCEDURE

1. PRECONDITIONING

If "DTC CONFIRMATION PROCEDURE" has been previously conducted, always turn the ignition switch OFF and wait at least 10 seconds before conducting the next test.

>> GO TO 2.

2. DTC REPRODUCTION PROCEDURE

1. Turn the ignition switch OFF to ON.
2. Perform self-diagnosis for "ABS" with CONSULT.

Is DTC "C1116" detected?

- YES >> Proceed to diagnosis procedure. Refer to [BRC-56, "Diagnosis Procedure"](#).
NO >> INSPECTION END

Diagnosis Procedure

INFOID:000000008457286

1. CHECK CONNECTOR

1. Turn the ignition switch OFF.
2. Disconnect ABS actuator and electric unit (control unit) harness connector.
3. Disconnect stop lamp switch harness connector.
4. Check the terminal for deformation, disconnection, looseness, etc.
5. Reconnect ABS actuator and electric unit (control unit) and stop lamp switch harness connectors securely.
6. Start the engine.
7. Repeat pumping brake pedal carefully several times, and perform self-diagnosis for "ABS" with CONSULT.

Is the inspection result normal?

- YES >> GO TO 2.
NO >> Poor connection of connector terminal. Repair or replace error-detected parts.

2. CHECK STOP LAMP SWITCH CLEARANCE

Check the stop lamp switch clearance. Refer to [BR-8, "Inspection and Adjustment"](#).

Is the inspection result normal?

- YES >> GO TO 3.
NO >> Adjust stop lamp switch clearance. Refer to [BR-8, "Inspection and Adjustment"](#).

3. CHECK STOP LAMP SWITCH

Check the stop lamp switch. Refer to [BRC-57, "Component Inspection"](#).

Is the inspection result normal?

- YES >> GO TO 4.

C1116 STOP LAMP SWITCH

[VDC/TCS/ABS]

< DTC/CIRCUIT DIAGNOSIS >

NO >> Repair or replace stop lamp switch.

4.CHECK STOP LAMP SWITCH CIRCUIT

1. Connect ABS actuator and electric unit (control unit) harness connector.
2. Check the voltage between ABS actuator and electric unit (control unit) harness connector and ground.

ABS actuator and electric unit (control unit)		—	Condition	Voltage (Approx.)
Connector	Terminal			
E36	16	Ground	Brake pedal is depressed	Battery voltage
			Brake pedal is released	0 V

Is the inspection result normal?

YES >> Replace ABS actuator and electric unit (control unit). Refer to [BRC-125, "Exploded View"](#).

NO >> Repair or replace error-detected parts.

Component Inspection

INFOID:000000008457287

1.CHECK STOP LAMP SWITCH

1. Turn the ignition switch OFF.
2. Disconnect stop lamp switch harness connector.
3. Check the continuity between stop lamp switch connector terminals.

Stop lamp switch Terminal	Condition	Continuity
1 – 2	Release stop lamp switch (When brake pedal is depressed.)	Existed
	Push stop lamp switch (When brake pedal is released.)	Not existed

Is the inspection result normal?

YES >> INSPECTION END

NO >> Replace stop lamp switch. Refer to [BR-19, "Exploded View"](#).

Special Repair Requirement

INFOID:000000008457288

1.AJUSTMENT OF STEERING ANGLE SENSOR NEUTRAL POSITION AND CALIBRATION OF DECEL G SENSOR

- After replacing an ABS actuator and electric unit (control unit), be sure to perform the following procedure.
- Adjustment of steering angle sensor neutral position: Refer to [BRC-9, "ADJUSTMENT OF STEERING ANGLE SENSOR NEUTRAL POSITION : Description"](#).
- Calibration of decel G sensor: Refer to [BRC-10, "CALIBRATION OF DECEL G SENSOR : Description"](#).
- After removing an ABS actuator and electric unit (control unit), be sure to perform the following procedure.
- Calibration of decel G sensor: Refer to [BRC-10, "CALIBRATION OF DECEL G SENSOR : Description"](#).
- After removing/replacing a steering angle sensor, be sure to perform the following procedure.
- Adjustment of steering angle sensor neutral position: Refer to [BRC-9, "ADJUSTMENT OF STEERING ANGLE SENSOR NEUTRAL POSITION : Description"](#).
- After removing/replacing a yaw rate/side/decel G sensor, be sure to perform the following procedure.
- Calibration of decel G sensor: Refer to [BRC-10, "CALIBRATION OF DECEL G SENSOR : Description"](#).

>> END

C1120, C1122, C1124, C1126 IN ABS SOL

< DTC/CIRCUIT DIAGNOSIS >

[VDC/TCS/ABS]

C1120, C1122, C1124, C1126 IN ABS SOL

Description

INFOID:000000008457289

The ABS IN valve increases, holds or decreases the fluid pressure of each brake caliper according to the signals transmitted by the ABS actuator and electric unit (control unit).

DTC Logic

INFOID:000000008457290

DTC DETECTION LOGIC

DTC	Display item	Malfunction detected condition	Possible cause
C1120	FR LH IN ABS SOL	When the control unit detects a malfunction in the front LH ABS IN valve circuit.	<ul style="list-style-type: none">• Harness or connector• ABS actuator and electric unit (control unit)
C1122	FR RH IN ABS SOL	When the control unit detects a malfunction in the front RH ABS IN valve circuit.	
C1124	RR LH IN ABS SOL	When the control unit detects a malfunction in the rear LH ABS IN valve circuit.	
C1126	RR RH IN ABS SOL	When the control unit detects a malfunction in the rear RH ABS IN valve circuit.	

DTC CONFIRMATION PROCEDURE

1. PRECONDITIONING

If "DTC CONFIRMATION PROCEDURE" has been previously conducted, always turn the ignition switch OFF and wait at least 10 seconds before conducting the next test.

>> GO TO 2.

2. DTC REPRODUCTION PROCEDURE

1. Turn the ignition switch OFF to ON.
2. Perform self-diagnosis for "ABS" with CONSULT.

Is DTC "C1120", "C1122", "C1124" or "C1126" detected?

YES >> Proceed to diagnosis procedure. Refer to [BRC-58, "Diagnosis Procedure"](#).

NO >> INSPECTION END

Diagnosis Procedure

INFOID:000000008457291

1. CHECK CONNECTOR

1. Turn the ignition switch OFF.
2. Disconnect ABS actuator and electric unit (control unit) harness connector.
3. Check the terminal for deformation, disconnection, looseness, etc.

Is the inspection result normal?

YES >> GO TO 2.

NO >> Repair or replace error-detected parts.

2. CHECK ABS IN VALVE POWER SUPPLY

1. Check the voltage between ABS actuator and electric unit (control unit) harness connector and ground.

ABS actuator and electric unit (control unit)		—	Voltage (Approx.)
Connector	Terminal		
E36	1	Ground	Battery voltage

2. Turn the ignition switch ON.

CAUTION:

Never start the engine.

3. Check the voltage between ABS actuator and electric unit (control unit) harness connector and ground.

ABS actuator and electric unit (control unit)		—	Voltage (Approx.)
Connector	Terminal		
E36	1	Ground	Battery voltage

Is the inspection result normal?

- YES >> GO TO 4.
- NO >> GO TO 3.

3.CHECK ABS IN VALVE POWER SUPPLY CIRCUIT

1. Turn the ignition switch OFF.
2. Check the 20A fusible link (#G).
3. Check the continuity and short circuit between ABS actuator and electric unit (control unit) harness connector terminal (1) and 20A fusible link (#G).

Is the inspection result normal?

- YES >> Perform trouble diagnosis for battery power supply. Refer to [PG-6. "Wiring Diagram - BATTERY POWER SUPPLY -"](#).
- NO >> Repair or replace error-detected parts.

4.CHECK ABS IN VALVE GROUND CIRCUIT

Check the continuity between ABS actuator and electric unit (control unit) harness connector and ground.

ABS actuator and electric unit (control unit)		—	Continuity
Connector	Terminal		
E36	13	Ground	Existed
	26		

Is the inspection result normal?

- YES >> Replace ABS actuator and electric unit (control unit). Refer to [BRC-125. "Exploded View"](#).
- NO >> Repair or replace error-detected parts.

Special Repair Requirement

INFOID:000000008457292

1.ADJUSTMENT OF STEERING ANGLE SENSOR NEUTRAL POSITION AND CALIBRATION OF DECEL G SENSOR

- After replacing an ABS actuator and electric unit (control unit), be sure to perform the following procedure.
 - Adjustment of steering angle sensor neutral position: Refer to [BRC-9. "ADJUSTMENT OF STEERING ANGLE SENSOR NEUTRAL POSITION : Description"](#).
 - Calibration of decel G sensor: Refer to [BRC-10. "CALIBRATION OF DECEL G SENSOR : Description"](#).
- After removing an ABS actuator and electric unit (control unit), be sure to perform the following procedure.
 - Calibration of decel G sensor: Refer to [BRC-10. "CALIBRATION OF DECEL G SENSOR : Description"](#).
- After removing/replacing a steering angle sensor, be sure to perform the following procedure.
 - Adjustment of steering angle sensor neutral position: Refer to [BRC-9. "ADJUSTMENT OF STEERING ANGLE SENSOR NEUTRAL POSITION : Description"](#).
- After removing/replacing a yaw rate/side/decel G sensor, be sure to perform the following procedure.
 - Calibration of decel G sensor: Refer to [BRC-10. "CALIBRATION OF DECEL G SENSOR : Description"](#).

>> END

C1121, C1123, C1125, C1127 OUT ABS SOL

< DTC/CIRCUIT DIAGNOSIS >

[VDC/TCS/ABS]

C1121, C1123, C1125, C1127 OUT ABS SOL

Description

INFOID:000000008457293

The ABS OUT valve increases, holds or decreases the fluid pressure of each brake caliper according to the signals transmitted by the ABS actuator and electric unit (control unit).

DTC Logic

INFOID:000000008457294

DTC DETECTION LOGIC

DTC	Display item	Malfunction detected condition	Possible cause
C1121	FR LH OUT ABS SOL	When the control unit detects a malfunction in the front LH ABS OUT valve circuit.	<ul style="list-style-type: none">• Harness or connector• ABS actuator and electric unit (control unit)
C1123	FR RH OUT ABS SOL	When the control unit detects a malfunction in the front RH ABS OUT valve circuit.	
C1125	RR LH OUT ABS SOL	When the control unit detects a malfunction in the rear LH ABS OUT valve circuit.	
C1127	RR RH OUT ABS SOL	When the control unit detects a malfunction in the rear RH ABS OUT valve circuit.	

DTC CONFIRMATION PROCEDURE

1. PRECONDITIONING

If "DTC CONFIRMATION PROCEDURE" has been previously conducted, always turn the ignition switch OFF and wait at least 10 seconds before conducting the next test.

>> GO TO 2.

2. DTC REPRODUCTION PROCEDURE

1. Turn the ignition switch OFF to ON.
2. Perform self-diagnosis for "ABS" with CONSULT.

Is DTC "C1121", "C1123", "C1125" or "C1127" detected?

- YES >> Proceed to diagnosis procedure. Refer to [BRC-60, "Diagnosis Procedure"](#).
NO >> INSPECTION END

Diagnosis Procedure

INFOID:000000008457295

1. CHECK CONNECTOR

1. Turn the ignition switch OFF.
2. Disconnect ABS actuator and electric unit (control unit) harness connector.
3. Check the terminal for deformation, disconnection, looseness, etc.

Is the inspection result normal?

- YES >> GO TO 2.
NO >> Repair or replace error-detected parts.

2. CHECK ABS OUT VALVE POWER SUPPLY

1. Check the voltage between ABS actuator and electric unit (control unit) harness connector and ground.

ABS actuator and electric unit (control unit)		—	Voltage (Approx.)
Connector	Terminal		
E36	1	Ground	Battery voltage

2. Turn the ignition switch ON.

CAUTION:

Never start the engine.

3. Check the voltage between ABS actuator and electric unit (control unit) harness connector and ground.

ABS actuator and electric unit (control unit)		—	Voltage (Approx.)
Connector	Terminal		
E36	1	Ground	Battery voltage

Is the inspection result normal?

- YES >> GO TO 4.
- NO >> GO TO 3.

3.CHECK ABS OUT VALVE POWER SUPPLY CIRCUIT

1. Turn the ignition switch OFF.
2. Check the 20A fusible link (#G).
3. Check the continuity and short circuit between ABS actuator and electric unit (control unit) harness connector terminal (1) and 20A fusible link (#G).

Is the inspection result normal?

- YES >> Perform trouble diagnosis for battery power supply. Refer to [PG-6. "Wiring Diagram - BATTERY POWER SUPPLY -"](#).
- NO >> Repair or replace error-detected parts.

4.CHECK ABS OUT VALVE GROUND CIRCUIT

Check the continuity between ABS actuator and electric unit (control unit) harness connector and ground.

ABS actuator and electric unit (control unit)		—	Continuity
Connector	Terminal		
E36	13	Ground	Existed
	26		

Is the inspection result normal?

- YES >> Replace ABS actuator and electric unit (control unit). Refer to [BRC-125. "Exploded View"](#).
- NO >> Repair or replace error-detected parts.

Special Repair Requirement

INFOID:000000008457296

1.AJUSTMENT OF STEERING ANGLE SENSOR NEUTRAL POSITION AND CALIBRATION OF DECEL G SENSOR

- After replacing an ABS actuator and electric unit (control unit), be sure to perform the following procedure.
 - Adjustment of steering angle sensor neutral position: Refer to [BRC-9. "ADJUSTMENT OF STEERING ANGLE SENSOR NEUTRAL POSITION : Description"](#).
 - Calibration of decel G sensor: Refer to [BRC-10. "CALIBRATION OF DECEL G SENSOR : Description"](#).
- After removing an ABS actuator and electric unit (control unit), be sure to perform the following procedure.
 - Calibration of decel G sensor: Refer to [BRC-10. "CALIBRATION OF DECEL G SENSOR : Description"](#).
- After removing/replacing a steering angle sensor, be sure to perform the following procedure.
 - Adjustment of steering angle sensor neutral position: Refer to [BRC-9. "ADJUSTMENT OF STEERING ANGLE SENSOR NEUTRAL POSITION : Description"](#).
- After removing/replacing a yaw rate/side/decel G sensor, be sure to perform the following procedure.
 - Calibration of decel G sensor: Refer to [BRC-10. "CALIBRATION OF DECEL G SENSOR : Description"](#).

>> END

C1130 ENGINE SIGNAL

Description

INFOID:000000008457297

ABS actuator and electric unit (control unit) and ECM exchange the engine signal via CAN communication line.

DTC Logic

INFOID:000000008457298

DTC DETECTION LOGIC

DTC	Display item	Malfunction detected condition	Possible cause
C1130	ENGINE SIGNAL 1	Major engine components are malfunctioning.	<ul style="list-style-type: none"> • ECM • ABS actuator and electric unit (control unit) • CAN communication line

DTC CONFIRMATION PROCEDURE

1. PRECONDITIONING

If "DTC CONFIRMATION PROCEDURE" has been previously conducted, always turn the ignition switch OFF and wait at least 10 seconds before conducting the next test.

>> GO TO 2.

2. DTC REPRODUCTION PROCEDURE

1. Turn the ignition switch OFF to ON.
2. Perform self-diagnosis for "ABS" with CONSULT.

Is DTC "C1130" detected?

- YES >> Proceed to diagnosis procedure. Refer to [BRC-62. "Diagnosis Procedure"](#).
 NO >> INSPECTION END

Diagnosis Procedure

INFOID:000000008457299

1. PERFORM SELF-DIAGNOSIS (1)

Perform self-diagnosis for "ENGINE" with CONSULT.

Is any item indicated on the self-diagnosis display?

- YES >> Check the malfunctioning system. Refer to [EC-128. "CONSULT Function"](#).
 NO >> GO TO 2.

2. PERFORM SELF-DIAGNOSIS (2)

1. Erase self-diagnosis results for "ABS" with CONSULT.
2. Turn the ignition switch OFF.
3. Start the engine. Drive the vehicle for a while.
4. Make sure that malfunction indicator lamp (MIL) turns OFF.

Is indicator lamp (MIL) turns OFF?

- YES >> GO TO 3.
 NO >> Refer to [EC-128. "CONSULT Function"](#).

3. PERFORM SELF-DIAGNOSIS (3)

Stop the vehicle. Perform self-diagnosis for "ENGINE" with CONSULT.

Is any item indicated on the self-diagnosis display?

- YES >> Replace ABS actuator and electric unit (control unit). Refer to [BRC-125. "Exploded View"](#).
 NO >> Repair or replace error-detected parts.

Special Repair Requirement

INFOID:000000008457300

1. ADJUSTMENT OF STEERING ANGLE SENSOR NEUTRAL POSITION AND CALIBRATION OF DECEL G

C1130 ENGINE SIGNAL

< DTC/CIRCUIT DIAGNOSIS >

[VDC/TCS/ABS]

SENSOR

- After replacing an ABS actuator and electric unit (control unit), be sure to perform the following procedure.
- Adjustment of steering angle sensor neutral position: Refer to [BRC-9, "ADJUSTMENT OF STEERING ANGLE SENSOR NEUTRAL POSITION : Description"](#).
- Calibration of decel G sensor: Refer to [BRC-10, "CALIBRATION OF DECEL G SENSOR : Description"](#).
- After removing an ABS actuator and electric unit (control unit), be sure to perform the following procedure.
- Calibration of decel G sensor: Refer to [BRC-10, "CALIBRATION OF DECEL G SENSOR : Description"](#).
- After removing/replacing a steering angle sensor, be sure to perform the following procedure.
- Adjustment of steering angle sensor neutral position: Refer to [BRC-9, "ADJUSTMENT OF STEERING ANGLE SENSOR NEUTRAL POSITION : Description"](#).
- After removing/replacing a yaw rate/side/decel G sensor, be sure to perform the following procedure.
- Calibration of decel G sensor: Refer to [BRC-10, "CALIBRATION OF DECEL G SENSOR : Description"](#).

>> END

A
B
C
D
E
G
H
I
J
K
L
M
N
O
P

BRC

C1140 ACTUATOR RELAY SYSTEM

< DTC/CIRCUIT DIAGNOSIS >

[VDC/TCS/ABS]

C1140 ACTUATOR RELAY SYSTEM

Description

INFOID:000000008457301

Activates or deactivates each valve according to the signals transmitted by the ABS actuator and electric unit (control unit).

DTC Logic

INFOID:000000008457302

DTC DETECTION LOGIC

DTC	Display item	Malfunction detected condition	Possible cause
C1140	ACTUATOR RLY	When the control unit detects a malfunction in the actuator relay system.	<ul style="list-style-type: none"> • Harness or connector • ABS actuator and electric unit (control unit)

DTC CONFIRMATION PROCEDURE

1. PRECONDITIONING

If "DTC CONFIRMATION PROCEDURE" has been previously conducted, always turn the ignition switch OFF and wait at least 10 seconds before conducting the next test.

>> GO TO 2.

2. DTC REPRODUCTION PROCEDURE

1. Turn the ignition switch OFF to ON.
2. Perform self-diagnosis for "ABS" with CONSULT.

Is DTC "C1140" detected?

- YES >> Proceed to diagnosis procedure. Refer to [BRC-64, "Diagnosis Procedure"](#).
 NO >> INSPECTION END

Diagnosis Procedure

INFOID:000000008457303

1. CHECK CONNECTOR

1. Turn the ignition switch OFF.
2. Disconnect ABS actuator and electric unit (control unit) harness connector.
3. Check the terminal for deformation, disconnection, looseness, etc.

Is the inspection result normal?

- YES >> GO TO 2.
 NO >> Repair or replace error-detected parts.

2. CHECK ACTUATOR RELAY POWER SUPPLY

1. Check the voltage between ABS actuator and electric unit (control unit) harness connector and ground.

ABS actuator and electric unit (control unit)		—	Voltage (Approx.)
Connector	Terminal		
E36	1	Ground	Battery voltage

2. Turn the ignition switch ON.

CAUTION:

Never start the engine.

3. Check the voltage between ABS actuator and electric unit (control unit) harness connector and ground.

ABS actuator and electric unit (control unit)		—	Voltage (Approx.)
Connector	Terminal		
E36	1	Ground	Battery voltage

Is the inspection result normal?

C1140 ACTUATOR RELAY SYSTEM

[VDC/TCS/ABS]

< DTC/CIRCUIT DIAGNOSIS >

- YES >> GO TO 4.
- NO >> GO TO 3.

3. CHECK ACTUATOR RELAY POWER SUPPLY CIRCUIT

1. Turn the ignition switch OFF.
2. Check the 20A fusible link (#G).
3. Check the continuity and short circuit between ABS actuator and electric unit (control unit) harness connector terminal (1) and 20A fusible link (#G).

Is the inspection result normal?

- YES >> Perform trouble diagnosis for battery power supply. Refer to [PG-6, "Wiring Diagram - BATTERY POWER SUPPLY -"](#).
- NO >> Repair or replace error-detected parts.

4. CHECK ACTUATOR RELAY GROUND CIRCUIT

Check the continuity between ABS actuator and electric unit (control unit) harness connector and ground.

ABS actuator and electric unit (control unit)		—	Continuity
Connector	Terminal		
E36	13	Ground	Existed
	26		

Is the inspection result normal?

- YES >> Replace ABS actuator and electric unit (control unit). Refer to [BRC-125, "Exploded View"](#).
- NO >> Repair or replace error-detected parts.

Special Repair Requirement

INFOID:000000008457304

1. ADJUSTMENT OF STEERING ANGLE SENSOR NEUTRAL POSITION AND CALIBRATION OF DECEL G SENSOR

- After replacing an ABS actuator and electric unit (control unit), be sure to perform the following procedure.
 - Adjustment of steering angle sensor neutral position: Refer to [BRC-9, "ADJUSTMENT OF STEERING ANGLE SENSOR NEUTRAL POSITION : Description"](#).
 - Calibration of decel G sensor: Refer to [BRC-10, "CALIBRATION OF DECEL G SENSOR : Description"](#).
- After removing an ABS actuator and electric unit (control unit), be sure to perform the following procedure.
 - Calibration of decel G sensor: Refer to [BRC-10, "CALIBRATION OF DECEL G SENSOR : Description"](#).
- After removing/replacing a steering angle sensor, be sure to perform the following procedure.
 - Adjustment of steering angle sensor neutral position: Refer to [BRC-9, "ADJUSTMENT OF STEERING ANGLE SENSOR NEUTRAL POSITION : Description"](#).
- After removing/replacing a yaw rate/side/decel G sensor, be sure to perform the following procedure.
 - Calibration of decel G sensor: Refer to [BRC-10, "CALIBRATION OF DECEL G SENSOR : Description"](#).

>> END

< DTC/CIRCUIT DIAGNOSIS >

C1142 PRESS SENSOR**Description**

INFOID:000000008457305

The pressure sensor converts the brake fluid pressure to an electric signal and transmits it to the ABS actuator and electric unit (control unit). [The pressure sensor is integrated in the ABS actuator and electric unit (control unit).]

DTC Logic

INFOID:000000008457306

DTC DETECTION LOGIC

DTC	Display item	Malfunction detected condition	Possible cause
C1142	PRESS SEN CIRCUIT	Pressure sensor signal line is open or shorted, or pressure sensor is malfunctioning.	<ul style="list-style-type: none"> • Harness or connector • Stop lamp switch • ABS actuator and electric unit (control unit)

DTC CONFIRMATION PROCEDURE**1. PRECONDITIONING**

If "DTC CONFIRMATION PROCEDURE" has been previously conducted, always turn the ignition switch OFF and wait at least 10 seconds before conducting the next test.

>> GO TO 2.

2. DTC REPRODUCTION PROCEDURE

1. Turn the ignition switch OFF to ON.
2. Perform self-diagnosis for "ABS" with CONSULT.

Is DTC "C1142" detected?

- YES >> Proceed to diagnosis procedure. Refer to [BRC-66, "Diagnosis Procedure"](#).
 NO >> INSPECTION END

Diagnosis Procedure

INFOID:000000008457307

1. CHECK STOP LAMP SWITCH SYSTEM

Check the stop lamp switch system. Refer to [BRC-56, "Diagnosis Procedure"](#).

Is the inspection result normal?

- YES >> GO TO 2.
 NO >> Repair or replace error-detected parts.

2. CHECK DATA MONITOR

1. Check the brake fluid leakage. Refer to [BR-11, "Inspection"](#).
2. Check the front brake piping. Refer to [BR-23, "FRONT : Inspection"](#).
3. Check the rear brake piping. Refer to [BR-25, "REAR : Inspection"](#).
4. Check the brake pedal. Refer to [BR-20, "Inspection and Adjustment"](#).
5. Check the master cylinder. Refer to [BR-28, "Inspection"](#).
6. Check the brake booster. Refer to [BR-30, "Inspection and Adjustment"](#).
7. Check the front disc brake. Refer to [BR-41, "BRAKE CALIPER ASSEMBLY \(1 PISTON TYPE\) : Inspection"](#) (1 piston type), [BR-45, "BRAKE CALIPER ASSEMBLY \(2 PISTON TYPE\) : Inspection"](#) (2 piston type).
8. Check the rear disc brake. Refer to [BR-51, "BRAKE CALIPER ASSEMBLY : Inspection"](#).

Is the inspection result normal?

- YES >> GO TO 3.
 NO >> Repair or replace error-detected parts.

3. PERFORM SELF-DIAGNOSIS

Perform self-diagnosis for "ABS" with CONSULT.

C1142 PRESS SENSOR

< DTC/CIRCUIT DIAGNOSIS >

[VDC/TCS/ABS]

Is any item indicated on the self-diagnosis display?

- YES >> Replace ABS actuator and electric unit (control unit). Refer to [BRC-125, "Exploded View"](#).
- NO >> Repair or replace error-detected parts.

Special Repair Requirement

INFOID:000000008457308

1. ADJUSTMENT OF STEERING ANGLE SENSOR NEUTRAL POSITION AND CALIBRATION OF DECEL G SENSOR

- After replacing an ABS actuator and electric unit (control unit), be sure to perform the following procedure.
- Adjustment of steering angle sensor neutral position: Refer to [BRC-9, "ADJUSTMENT OF STEERING ANGLE SENSOR NEUTRAL POSITION : Description"](#).
- Calibration of decel G sensor: Refer to [BRC-10, "CALIBRATION OF DECEL G SENSOR : Description"](#).
- After removing an ABS actuator and electric unit (control unit), be sure to perform the following procedure.
- Calibration of decel G sensor: Refer to [BRC-10, "CALIBRATION OF DECEL G SENSOR : Description"](#).
- After removing/replacing a steering angle sensor, be sure to perform the following procedure.
- Adjustment of steering angle sensor neutral position: Refer to [BRC-9, "ADJUSTMENT OF STEERING ANGLE SENSOR NEUTRAL POSITION : Description"](#).
- After removing/replacing a yaw rate/side/decel G sensor, be sure to perform the following procedure.
- Calibration of decel G sensor: Refer to [BRC-10, "CALIBRATION OF DECEL G SENSOR : Description"](#).

>> END

A
B
C
D
E
BRC
G
H
I
J
K
L
M
N
O
P

C1143 STEERING ANGLE SENSOR

< DTC/CIRCUIT DIAGNOSIS >

[VDC/TCS/ABS]

C1143 STEERING ANGLE SENSOR

Description

INFOID:000000008457309

The steering angle sensor detects the rotation amount, angular velocity and direction of the steering wheel, and transmits the data to the ABS actuator and electric unit (control unit) via CAN communication.

DTC Logic

INFOID:000000008457310

DTC DETECTION LOGIC

DTC	Display item	Malfunction detected condition	Possible cause
C1143	ST ANG SEN CIRCUIT	Neutral position of steering angle sensor is dislocated, steering angle sensor is malfunctioning, or wheel alignment is outside specified range.	<ul style="list-style-type: none">• Harness or connector• Steering angle sensor• ABS actuator and electric unit (control unit)• Wheel alignment

DTC CONFIRMATION PROCEDURE

1. PRECONDITIONING

If "DTC CONFIRMATION PROCEDURE" has been previously conducted, always turn the ignition switch OFF and wait at least 10 seconds before conducting the next test.

>> GO TO 2.

2. DTC REPRODUCTION PROCEDURE

1. Turn the ignition switch OFF to ON.
2. Perform self-diagnosis for "ABS" with CONSULT.

Is DTC "C1143" detected?

- YES >> Proceed to diagnosis procedure. Refer to [BRC-68, "Diagnosis Procedure"](#).
NO >> INSPECTION END

Diagnosis Procedure

INFOID:000000008457311

1. CHECK WHEEL ALIGNMENT

Check the wheel alignment. Refer to [FSU-7, "Inspection"](#) (front), [RSU-6, "Inspection"](#) (rear).

Is the inspection result normal?

- YES >> GO TO 2.
NO >> Adjust wheel alignment. Refer to [FSU-7, "Inspection"](#) (front), [RSU-6, "Adjustment"](#) (rear).

2. CHECK CONNECTOR

1. Turn the ignition switch OFF.
2. Disconnect ABS actuator and electric unit (control unit) harness connector.
3. Disconnect steering angle sensor harness connector.
4. Check the terminal for deformation, disconnection, looseness, etc.

Is the inspection result normal?

- YES >> GO TO 3.
NO >> Repair or replace error-detected parts.

3. CHECK STEERING ANGLE SENSOR POWER SUPPLY

1. Check the voltage between steering angle sensor harness connector and ground.

Steering angle sensor		—	Voltage (Approx.)
Connector	Terminal		
M30	4	Ground	0 V

2. Turn the ignition switch ON.

C1143 STEERING ANGLE SENSOR

[VDC/TCS/ABS]

< DTC/CIRCUIT DIAGNOSIS >

CAUTION:

Never start the engine.

3. Check the voltage between steering angle sensor harness connector and ground.

Steering angle sensor		—	Voltage (Approx.)
Connector	Terminal		
M30	4	Ground	Battery voltage

Is the inspection result normal?

YES >> GO TO 5.

NO >> GO TO 4.

4.CHECK STEERING ANGLE SENSOR POWER SUPPLY CIRCUIT

1. Turn the ignition switch OFF.
2. Check the 10A fuse (#3).
3. Disconnect fuse block (J/B) harness connector.
4. Check the continuity between steering angle sensor harness connector and fuse block (J/B) harness connector.

Steering angle sensor		Fuse block (J/B)		Continuity
Connector	Terminal	Connector	Terminal	
M30	4	M1	2A	Existed

Is the inspection result normal?

YES >> Perform trouble diagnosis for ignition power supply. Refer to [PG-21, "Wiring Diagram - IGNITION POWER SUPPLY -"](#).

NO >> Repair or replace error-detected parts.

5.CHECK STEERING ANGLE SENSOR GROUND CIRCUIT

Check the continuity between steering angle sensor harness connector and ground.

Steering angle sensor		—	Continuity
Connector	Terminal		
M30	1	Ground	Existed

Is the inspection result normal?

YES >> GO TO 6.

NO >> Repair or replace error-detected parts.

6.CHECK STEERING WHEEL PLAY

Check the steering wheel play. Refer to [ST-33, "Inspection"](#).

Is the inspection result normal?

YES >> GO TO 7.

NO >> Repair or replace error-detected parts.

7.CHECK CAN COMMUNICATION LINE

Check the "STRG BRANCH LINE CIRCUIT". Refer to [LAN-53, "Diagnosis Procedure"](#).

Is the inspection result normal?

YES >> GO TO 8.

NO >> Repair or replace error-detected parts. Refer to [LAN-24, "FOR USA AND CANADA : Precautions for Harness Repair"](#) (for USA and Canada), [LAN-26, "FOR MEXICO : Precautions for Harness Repair"](#) (for Mexico).

8.CHECK DATA MONITOR

1. Connect the ABS actuator and electric unit (control unit) harness connector.
2. Connect the steering angle sensor harness connector.
3. Check the steering angle sensor signal. Refer to [BRC-102, "Reference Value"](#).

A
B
C
D
E
G
H
I
J
K
L
M
N
O
P

BRC

C1143 STEERING ANGLE SENSOR

[VDC/TCS/ABS]

< DTC/CIRCUIT DIAGNOSIS >

Is the inspection result normal?

YES >> Replace ABS actuator and electric unit (control unit). Refer to [BRC-125, "Exploded View"](#).

NO >> Replace steering angle sensor. Refer to [BRC-128, "Exploded View"](#).

Special Repair Requirement

INFOID:000000008457312

1. ADJUSTMENT OF STEERING ANGLE SENSOR NEUTRAL POSITION AND CALIBRATION OF DECEL G SENSOR

- After replacing an ABS actuator and electric unit (control unit), be sure to perform the following procedure.
- Adjustment of steering angle sensor neutral position: Refer to [BRC-9, "ADJUSTMENT OF STEERING ANGLE SENSOR NEUTRAL POSITION : Description"](#).
- Calibration of decel G sensor: Refer to [BRC-10, "CALIBRATION OF DECEL G SENSOR : Description"](#).
- After removing an ABS actuator and electric unit (control unit), be sure to perform the following procedure.
- Calibration of decel G sensor: Refer to [BRC-10, "CALIBRATION OF DECEL G SENSOR : Description"](#).
- After removing/replacing a steering angle sensor, be sure to perform the following procedure.
- Adjustment of steering angle sensor neutral position: Refer to [BRC-9, "ADJUSTMENT OF STEERING ANGLE SENSOR NEUTRAL POSITION : Description"](#).
- After removing/replacing a yaw rate/side/decel G sensor, be sure to perform the following procedure.
- Calibration of decel G sensor: Refer to [BRC-10, "CALIBRATION OF DECEL G SENSOR : Description"](#).

>> END

C1144 INCOMPLETE STEERING ANGLE SENSOR ADJUSTMENT

< DTC/CIRCUIT DIAGNOSIS >

[VDC/TCS/ABS]

C1144 INCOMPLETE STEERING ANGLE SENSOR ADJUSTMENT

Description

INFOID:000000008457313

The steering angle sensor detects the rotation amount, angular velocity and direction of the steering wheel, and transmits the data to the ABS actuator and electric unit (control unit) via CAN communication.

DTC Logic

INFOID:000000008457314

DTC DETECTION LOGIC

DTC	Display item	Malfunction detected condition	Possible cause
C1144	ST ANG SEN SIGNAL	Adjustment of steering angle sensor neutral position is not finished.	<ul style="list-style-type: none">• Harness or connector• Steering angle sensor• ABS actuator and electric unit (control unit)

DTC CONFIRMATION PROCEDURE

1. PRECONDITIONING

If "DTC CONFIRMATION PROCEDURE" has been previously conducted, always turn the ignition switch OFF and wait at least 10 seconds before conducting the next test.

>> GO TO 2.

2. DTC REPRODUCTION PROCEDURE

1. Turn the ignition switch OFF to ON.
2. Select "ABS", "WORK SUPPORT" and "ST ANGLE SENSOR ADJUSTMENT" in order with CONSULT, and perform adjust the neutral position of steering angle sensor.
3. Perform self-diagnosis for "ABS" with CONSULT.

Is DTC "C1144" detected?

- YES >> Proceed to diagnosis procedure. Refer to [BRC-71, "Diagnosis Procedure"](#).
NO >> INSPECTION END

Diagnosis Procedure

INFOID:000000008457315

1. CHECK STEERING ANGLE SENSOR

Check the steering angle sensor. Refer to [BRC-68, "Diagnosis Procedure"](#).

Is the inspection result normal?

- YES >> Replace ABS actuator and electric unit (control unit). Refer to [BRC-125, "Exploded View"](#).
NO >> Repair or replace error-detected parts.

Special Repair Requirement

INFOID:000000008457316

1. ADJUSTMENT OF STEERING ANGLE SENSOR NEUTRAL POSITION AND CALIBRATION OF DECEL G SENSOR

- After replacing an ABS actuator and electric unit (control unit), be sure to perform the following procedure.
 - Adjustment of steering angle sensor neutral position: Refer to [BRC-9, "ADJUSTMENT OF STEERING ANGLE SENSOR NEUTRAL POSITION : Description"](#).
 - Calibration of decel G sensor: Refer to [BRC-10, "CALIBRATION OF DECEL G SENSOR : Description"](#).
- After removing an ABS actuator and electric unit (control unit), be sure to perform the following procedure.
 - Calibration of decel G sensor: Refer to [BRC-10, "CALIBRATION OF DECEL G SENSOR : Description"](#).
- After removing/replacing a steering angle sensor, be sure to perform the following procedure.
 - Adjustment of steering angle sensor neutral position: Refer to [BRC-9, "ADJUSTMENT OF STEERING ANGLE SENSOR NEUTRAL POSITION : Description"](#).
- After removing/replacing a yaw rate/side/decel G sensor, be sure to perform the following procedure.
 - Calibration of decel G sensor: Refer to [BRC-10, "CALIBRATION OF DECEL G SENSOR : Description"](#).

C1144 INCOMPLETE STEERING ANGLE SENSOR ADJUSTMENT

< DTC/CIRCUIT DIAGNOSIS >

[VDC/TCS/ABS]

>> END

C1155 BRAKE FLUID LEVEL SWITCH

< DTC/CIRCUIT DIAGNOSIS >

[VDC/TCS/ABS]

C1155 BRAKE FLUID LEVEL SWITCH

Description

INFOID:000000008457317

The brake fluid level switch converts the brake fluid level to an electric signal and transmits it to the ABS actuator and electric unit (control unit).

DTC Logic

INFOID:000000008457318

DTC DETECTION LOGIC

DTC	Display item	Malfunction detected condition	Possible cause
C1155	BR FLUID LEVEL LOW	Brake fluid level is low or communication line between the ABS actuator and electric unit (control unit) and brake fluid level switch is open or shorted.	<ul style="list-style-type: none">• Harness or connector• ABS actuator and electric unit (control unit)• Brake fluid level low• Brake fluid level switch• Combination meter

DTC CONFIRMATION PROCEDURE

1. PRECONDITIONING

If "DTC CONFIRMATION PROCEDURE" has been previously conducted, always turn the ignition switch OFF and wait at least 10 seconds before conducting the next test.

>> GO TO 2.

2. DTC REPRODUCTION PROCEDURE

1. Turn the ignition switch OFF to ON.
2. Perform self-diagnosis for "ABS" with CONSULT.

Is DTC "C1155" detected?

- YES >> Proceed to diagnosis procedure. Refer to [BRC-73, "Diagnosis Procedure"](#).
NO >> INSPECTION END

Diagnosis Procedure

INFOID:000000008457319

1. CHECK BRAKE FLUID LEVEL

1. Turn the ignition switch OFF.
2. Check the brake fluid level. Refer to [BR-11, "Inspection"](#).

Is the inspection result normal?

- YES >> GO TO 2.
NO >> Refill brake fluid. Refer to [BR-11, "Refilling"](#).

2. PERFORM SELF-DIAGNOSIS (1)

1. Erase self-diagnosis result for "ABS" with CONSULT.
2. Turn the ignition switch OFF, and wait 10 seconds or more.
3. Turn the ignition switch ON.

CAUTION:

Never start the engine.

4. Perform self-diagnosis for "ABS" with CONSULT.

Is DTC "C1155" detected?

- YES >> INSPECTION END
NO >> GO TO 3.

3. CHECK BRAKE FLUID LEVEL SWITCH

Check the brake fluids level switch. Refer to [BRC-75, "Component Inspection"](#).

Is the inspection result normal?

- YES >> GO TO 5.

C1155 BRAKE FLUID LEVEL SWITCH

[VDC/TCS/ABS]

< DTC/CIRCUIT DIAGNOSIS >

NO >> Replace sub tank. Refer to [BR-26. "Exploded View"](#). GO TO 4.

4.PERFORM SELF-DIAGNOSIS (2)

1. Erase self-diagnosis result for "ABS" with CONSULT.
2. Turn the ignition switch OFF, and wait 10 seconds or more.
3. Turn the ignition switch ON.

CAUTION:

Never start the engine.

4. Perform self-diagnosis for "ABS" with CONSULT.

Is DTC "C1155" detected?

YES >> INSPECTION END

NO >> GO TO 5.

5.CHECK CONNECTOR AND TERMINAL

1. Turn the ignition switch OFF.
2. Disconnect brake fluid level switch harness connector.
3. Check the brake fluid level switch harness connector for disconnection or looseness.
4. Check the brake fluid level switch pin terminals for damage or loose connection with harness connector.
5. Disconnect combination meter harness connector.
6. Check the combination meter harness connector for disconnection or looseness.
7. Check the combination meter pin terminals for damage or loose connection with harness connector.
8. Disconnect ABS actuator and electric unit (control unit) harness connector.
9. Check the ABS actuator and electric unit (control unit) harness connector for disconnection or looseness.
10. Check the ABS actuator and electric unit (control unit) harness connector pin terminals for damage or loose connection with harness connector.

Is the inspection result normal?

YES >> GO TO 7.

NO >> Repair or replace error-detected parts. GO TO 6.

6.PERFORM SELF-DIAGNOSIS (3)

1. Connect brake fluid level switch harness connector.
2. Connect combination meter harness connector.
3. Connect ABS actuator and electric unit (control unit) harness connector.
4. Erase self-diagnosis result for "ABS" with CONSULT.
5. Turn the ignition switch OFF, and wait 10 seconds or more.
6. Turn the ignition switch ON.

CAUTION:

Never start the engine.

7. Perform self-diagnosis for "ABS" with CONSULT.

Is DTC "C1155" detected?

YES >> INSPECTION END

NO >> GO TO 7.

7.CHECK BRAKE FLUID LEVEL SWITCH CIRCUIT

1. Turn the ignition switch OFF.
2. Disconnect brake fluid level switch harness connector.
3. Disconnect ABS actuator and electric unit (control unit) harness connector.
4. Disconnect combination meter harness connector.
5. Check the continuity between brake fluid level switch harness connector and ABS actuator and electric unit (control unit) harness connector.

Brake fluid level switch		ABS actuator and electric unit (control unit)		Continuity
Connector	Terminal	Connector	Terminal	
E37	1	E36	7	Existed

6. Check the continuity between brake fluid level switch harness connector and combination meter harness connector.

C1155 BRAKE FLUID LEVEL SWITCH

< DTC/CIRCUIT DIAGNOSIS >

[VDC/TCS/ABS]

Brake fluid level switch		Combination meter		Continuity
Connector	Terminal	Connector	Terminal	
E37	1	M34	27	Existed

7. Check the continuity between brake fluid level switch harness connector and ground.

Brake fluid level switch		—	Continuity
Connector	Terminal		
E37	1	Ground	Not existed

Is the inspection result normal?

YES >> GO TO 8.

NO >> Repair or replace error-detected parts.

8. CHECK BRAKE FLUID LEVEL SWITCH GROUND

Check the continuity between brake fluid level switch harness connector and ground.

Brake fluid level switch		—	Continuity
Connector	Terminal		
E37	2	Ground	Existed

Is the inspection result normal?

YES >> GO TO 9.

NO >> Repair or replace error-detected parts.

9. CHECK COMBINATION METER

Check the combination meter. Refer to [MWI-35, "CONSULT Function \(METER/M&A\)"](#).

Is the inspection result normal?

YES >> Replace ABS actuator and electric unit (control unit). Refer to [BRC-125, "Exploded View"](#).

NO >> Repair or replace combination meter. Refer to [MWI-94, "Exploded View"](#).

Component Inspection

INFOID:000000008457320

1. CHECK BRAKE FLUID LEVEL SWITCH

1. Turn the ignition switch OFF.
2. Disconnect brake fluid level switch harness connector.
3. Check the continuity between brake fluid level switch connector terminals.

Brake fluid level switch		Condition	Continuity
Terminal			
1 – 2		When brake fluid is full in the sub tank.	Not existed
		When brake fluid is empty in the sub tank.	Existed

Is the inspection result normal?

YES >> INSPECTION END

NO >> Replace sub tank. Refer to [BR-26, "Exploded View"](#).

Special Repair Requirement

INFOID:000000008457321

1. ADJUSTMENT OF STEERING ANGLE SENSOR NEUTRAL POSITION AND CALIBRATION OF DECEL G SENSOR

- After replacing an ABS actuator and electric unit (control unit), be sure to perform the following procedure.
 - Adjustment of steering angle sensor neutral position: Refer to [BRC-9, "ADJUSTMENT OF STEERING ANGLE SENSOR NEUTRAL POSITION : Description"](#).
 - Calibration of decel G sensor: Refer to [BRC-10, "CALIBRATION OF DECEL G SENSOR : Description"](#).

C1155 BRAKE FLUID LEVEL SWITCH

[VDC/TCS/ABS]

< DTC/CIRCUIT DIAGNOSIS >

- After removing an ABS actuator and electric unit (control unit), be sure to perform the following procedure.
- Calibration of decel G sensor: Refer to [BRC-10, "CALIBRATION OF DECEL G SENSOR : Description"](#).
- After removing/replacing a steering angle sensor, be sure to perform the following procedure.
- Adjustment of steering angle sensor neutral position: Refer to [BRC-9, "ADJUSTMENT OF STEERING ANGLE SENSOR NEUTRAL POSITION : Description"](#).
- After removing/replacing a yaw rate/side/decel G sensor, be sure to perform the following procedure.
- Calibration of decel G sensor: Refer to [BRC-10, "CALIBRATION OF DECEL G SENSOR : Description"](#).

>> END

C1160 INCOMPLETE DECEL G SENSOR CALIBRATION

< DTC/CIRCUIT DIAGNOSIS >

[VDC/TCS/ABS]

C1160 INCOMPLETE DECEL G SENSOR CALIBRATION

Description

INFOID:000000008457322

Yaw rate/side/decel G sensor detects decel G affecting the vehicle, and transmits the data to the ABS actuator and electric unit (control unit) as an analog voltage signal.

DTC Logic

INFOID:000000008457323

DTC DETECTION LOGIC

DTC	Display item	Malfunction detected condition	Possible cause
C1160	DECEL G SEN SET	Calibration of decel G sensor is not finished.	<ul style="list-style-type: none">• yaw rate/side/decel G sensor• Harness or connector• ABS actuator and electric unit (control unit)• Incomplete decel G sensor calibration

DTC CONFIRMATION PROCEDURE

1. PRECONDITIONING

If "DTC CONFIRMATION PROCEDURE" has been previously conducted, always turn the ignition switch OFF and wait at least 10 seconds before conducting the next test.

>> GO TO 2.

2. DTC REPRODUCTION PROCEDURE

1. Turn the ignition switch OFF to ON.
2. Select "ABS", "WORK SUPPORT" and "DECEL G SEN CALIBRATION" in order with CONSULT, and perform calibration of decel G sensor. Refer to [BRC-10. "CALIBRATION OF DECEL G SENSOR : Special Repair Requirement"](#).
3. Perform self-diagnosis for "ABS" with CONSULT.

Is DTC "C1160" detected?

- YES >> Proceed to diagnosis procedure. Refer to [BRC-77. "Diagnosis Procedure"](#).
NO >> INSPECTION END

Diagnosis Procedure

INFOID:000000008457324

1. CHECK YAW RATE/SIDE/DECEL G SENSOR

Check the yaw rate/side/decel G sensor. Refer to [BRC-102. "Reference Value"](#).

Is the inspection result normal?

- YES >> Replace ABS actuator and electric unit (control unit). Refer to [BRC-125. "Exploded View"](#).
NO >> Repair or replace error-detected parts.

Special Repair Requirement

INFOID:000000008457325

1. ADJUSTMENT OF STEERING ANGLE SENSOR NEUTRAL POSITION AND CALIBRATION OF DECEL G SENSOR

- After replacing an ABS actuator and electric unit (control unit), be sure to perform the following procedure.
 - Adjustment of steering angle sensor neutral position: Refer to [BRC-9. "ADJUSTMENT OF STEERING ANGLE SENSOR NEUTRAL POSITION : Description"](#).
 - Calibration of decel G sensor: Refer to [BRC-10. "CALIBRATION OF DECEL G SENSOR : Description"](#).
- After removing an ABS actuator and electric unit (control unit), be sure to perform the following procedure.
 - Calibration of decel G sensor: Refer to [BRC-10. "CALIBRATION OF DECEL G SENSOR : Description"](#).
- After removing/replacing a steering angle sensor, be sure to perform the following procedure.
 - Adjustment of steering angle sensor neutral position: Refer to [BRC-9. "ADJUSTMENT OF STEERING ANGLE SENSOR NEUTRAL POSITION : Description"](#).
- After removing/replacing a yaw rate/side/decel G sensor, be sure to perform the following procedure.

C1160 INCOMPLETE DECEL G SENSOR CALIBRATION

< DTC/CIRCUIT DIAGNOSIS >

[VDC/TCS/ABS]

- Calibration of decel G sensor: Refer to [BRC-10, "CALIBRATION OF DECEL G SENSOR : Description"](#).

>> END

C1161 INCOMPLETE SIDE G SENSOR CALIBRATION

< DTC/CIRCUIT DIAGNOSIS >

[VDC/TCS/ABS]

C1161 INCOMPLETE SIDE G SENSOR CALIBRATION

Description

INFOID:000000008457326

Yaw rate/side/decel G sensor detects side G affecting the vehicle, and transmits the data to the ABS actuator and electric unit (control unit) as an analog voltage signal.

DTC Logic

INFOID:000000008457327

DTC DETECTION LOGIC

DTC	Display item	Malfunction detected condition	Possible cause
C1161	SIDE G SEN SET	When there is an internal malfunction in the ABS actuator and electric unit (control unit).	ABS actuator and electric unit (control unit)

DTC CONFIRMATION PROCEDURE

1. PRECONDITIONING

If "DTC CONFIRMATION PROCEDURE" has been previously conducted, always turn the ignition switch OFF and wait at least 10 seconds before conducting the next test.

>> GO TO 2.

2. DTC REPRODUCTION PROCEDURE

1. Turn the ignition switch OFF to ON.
2. Perform self-diagnosis for "ABS" with CONSULT.

Is DTC "C1161" detected?

- YES >> Proceed to diagnosis procedure. Refer to [BRC-79. "Diagnosis Procedure"](#).
NO >> INSPECTION END

Diagnosis Procedure

INFOID:000000008457328

1. REPLACE ABS ACTUATOR AND ELECTRIC UNIT (CONTROL UNIT)

Replace ABS actuator and electric unit (control unit) when self-diagnostic result shows items other than those applicable.

>> Replace ABS actuator and electric unit (control unit). Refer to [BRC-125. "Exploded View"](#).

Special Repair Requirement

INFOID:000000008457329

1. ADJUSTMENT OF STEERING ANGLE SENSOR NEUTRAL POSITION AND CALIBRATION OF DECEL G SENSOR

- After replacing an ABS actuator and electric unit (control unit), be sure to perform the following procedure.
- Adjustment of steering angle sensor neutral position: Refer to [BRC-9. "ADJUSTMENT OF STEERING ANGLE SENSOR NEUTRAL POSITION : Description"](#).
- Calibration of decel G sensor: Refer to [BRC-10. "CALIBRATION OF DECEL G SENSOR : Description"](#).
- After removing an ABS actuator and electric unit (control unit), be sure to perform the following procedure.
- Calibration of decel G sensor: Refer to [BRC-10. "CALIBRATION OF DECEL G SENSOR : Description"](#).
- After removing/replacing a steering angle sensor, be sure to perform the following procedure.
- Adjustment of steering angle sensor neutral position: Refer to [BRC-9. "ADJUSTMENT OF STEERING ANGLE SENSOR NEUTRAL POSITION : Description"](#).
- After removing/replacing a yaw rate/side/decel G sensor, be sure to perform the following procedure.
- Calibration of decel G sensor: Refer to [BRC-10. "CALIBRATION OF DECEL G SENSOR : Description"](#).

>> END

C1162 INCOMPLETE PRESSURE SENSOR CALIBRATION

< DTC/CIRCUIT DIAGNOSIS >

[VDC/TCS/ABS]

C1162 INCOMPLETE PRESSURE SENSOR CALIBRATION

Description

INFOID:000000008457330

The pressure sensor converts the brake fluid pressure to an electric signal and transmits it to the ABS actuator and electric unit (control unit). [The pressure sensor is integrated in the ABS actuator and electric unit (control unit).]

DTC Logic

INFOID:000000008457331

DTC DETECTION LOGIC

DTC	Display item	Malfunction detected condition	Possible cause
C1162	PRESS SEN SET	When there is an internal malfunction in the ABS actuator and electric unit (control unit).	ABS actuator and electric unit (control unit)

DTC CONFIRMATION PROCEDURE

1. PRECONDITIONING

If "DTC CONFIRMATION PROCEDURE" has been previously conducted, always turn the ignition switch OFF and wait at least 10 seconds before conducting the next test.

>> GO TO 2.

2. DTC REPRODUCTION PROCEDURE

1. Turn the ignition switch OFF to ON.
2. Perform self-diagnosis for "ABS" with CONSULT.

Is DTC "C1162" detected?

- YES >> Proceed to diagnosis procedure. Refer to [BRC-80, "Diagnosis Procedure"](#).
NO >> INSPECTION END

Diagnosis Procedure

INFOID:000000008457332

1. REPLACE ABS ACTUATOR AND ELECTRIC UNIT (CONTROL UNIT)

Replace ABS actuator and electric unit (control unit) when self-diagnostic result shows items other than those applicable.

>> Replace ABS actuator and electric unit (control unit). Refer to [BRC-125, "Exploded View"](#).

Special Repair Requirement

INFOID:000000008457333

1. ADJUSTMENT OF STEERING ANGLE SENSOR NEUTRAL POSITION AND CALIBRATION OF DECEL G SENSOR

- After replacing an ABS actuator and electric unit (control unit), be sure to perform the following procedure.
- Adjustment of steering angle sensor neutral position: Refer to [BRC-9, "ADJUSTMENT OF STEERING ANGLE SENSOR NEUTRAL POSITION : Description"](#).
- Calibration of decel G sensor: Refer to [BRC-10, "CALIBRATION OF DECEL G SENSOR : Description"](#).
- After removing an ABS actuator and electric unit (control unit), be sure to perform the following procedure.
- Calibration of decel G sensor: Refer to [BRC-10, "CALIBRATION OF DECEL G SENSOR : Description"](#).
- After removing/replacing a steering angle sensor, be sure to perform the following procedure.
- Adjustment of steering angle sensor neutral position: Refer to [BRC-9, "ADJUSTMENT OF STEERING ANGLE SENSOR NEUTRAL POSITION : Description"](#).
- After removing/replacing a yaw rate/side/decel G sensor, be sure to perform the following procedure.
- Calibration of decel G sensor: Refer to [BRC-10, "CALIBRATION OF DECEL G SENSOR : Description"](#).

>> END

C1164, C1165 CV SYSTEM

Description

INFOID:000000008457334

The cut valve shuts off the normal brake fluid path from the master cylinder, when VDC/TCS is activated.

DTC Logic

INFOID:000000008457335

DTC DETECTION LOGIC

DTC	Display item	Malfunction detected condition	Possible cause
C1164	CV1	Cut valve 1 (CV1) on the primary side is open circuit or shorted, or the control line is open or shorted to the power supply or the ground.	<ul style="list-style-type: none"> • Harness or connector • ABS actuator and electric unit (control unit)
C1165	CV2	Cut valve 2 (CV2) on the secondary side is open circuit or shorted, or the control line is open or shorted to the power supply or the ground.	

DTC CONFIRMATION PROCEDURE

1. PRECONDITIONING

If "DTC CONFIRMATION PROCEDURE" has been previously conducted, always turn the ignition switch OFF and wait at least 10 seconds before conducting the next test.

>> GO TO 2.

2. DTC REPRODUCTION PROCEDURE

1. Turn the ignition switch OFF to ON.
2. Perform self-diagnosis for "ABS" with CONSULT.

Is DTC "C1164" or "C1165" detected?

- YES >> Proceed to diagnosis procedure. Refer to [BRC-81, "Diagnosis Procedure"](#).
 NO >> INSPECTION END

Diagnosis Procedure

INFOID:000000008457336

1. CHECK CONNECTOR

1. Turn the ignition switch OFF.
2. Disconnect ABS actuator and electric unit (control unit) harness connector.
3. Check the terminal for deformation, disconnection, looseness, etc.

Is the inspection result normal?

- YES >> GO TO 2.
 NO >> Repair or replace error-detected parts.

2. CHECK CUT VALVE (CV) POWER SUPPLY

1. Check the voltage between ABS actuator and electric unit (control unit) harness connector and ground.

ABS actuator and electric unit (control unit)		—	Voltage (Approx.)
Connector	Terminal		
E36	1	Ground	Battery voltage

2. Turn the ignition switch ON.
CAUTION:
Never start the engine.
3. Check the voltage between ABS actuator and electric unit (control unit) harness connector and ground.

ABS actuator and electric unit (control unit)		—	Voltage (Approx.)
Connector	Terminal		
E36	1	Ground	Battery voltage

Is the inspection result normal?

- YES >> GO TO 4.
- NO >> GO TO 3.

3. CHECK CUT VALVE (CV) POWER SUPPLY CIRCUIT

1. Turn the ignition switch OFF.
2. Check the 20A fusible link (#G).
3. Check the continuity and short circuit between ABS actuator and electric unit (control unit) harness connector terminal (1) and 20A fusible link (#G).

Is the inspection result normal?

- YES >> Perform trouble diagnosis for battery power supply. Refer to [PG-6. "Wiring Diagram - BATTERY POWER SUPPLY -"](#).
- NO >> Repair or replace error-detected parts.

4. CHECK CUT VALVE (CV) GROUND CIRCUIT

Check the continuity between ABS actuator and electric unit (control unit) harness connector and ground.

ABS actuator and electric unit (control unit)		—	Continuity
Connector	Terminal		
E36	13	Ground	Existed
	26		

Is the inspection result normal?

- YES >> Replace ABS actuator and electric unit (control unit). Refer to [BRC-125. "Exploded View"](#).
- NO >> Repair or replace error-detected parts.

Special Repair Requirement

INFOID:000000008457337

1. ADJUSTMENT OF STEERING ANGLE SENSOR NEUTRAL POSITION AND CALIBRATION OF DECEL G SENSOR

- After replacing an ABS actuator and electric unit (control unit), be sure to perform the following procedure.
 - Adjustment of steering angle sensor neutral position: Refer to [BRC-9. "ADJUSTMENT OF STEERING ANGLE SENSOR NEUTRAL POSITION : Description"](#).
 - Calibration of decel G sensor: Refer to [BRC-10. "CALIBRATION OF DECEL G SENSOR : Description"](#).
- After removing an ABS actuator and electric unit (control unit), be sure to perform the following procedure.
 - Calibration of decel G sensor: Refer to [BRC-10. "CALIBRATION OF DECEL G SENSOR : Description"](#).
- After removing/replacing a steering angle sensor, be sure to perform the following procedure.
 - Adjustment of steering angle sensor neutral position: Refer to [BRC-9. "ADJUSTMENT OF STEERING ANGLE SENSOR NEUTRAL POSITION : Description"](#).
- After removing/replacing a yaw rate/side/decel G sensor, be sure to perform the following procedure.
 - Calibration of decel G sensor: Refer to [BRC-10. "CALIBRATION OF DECEL G SENSOR : Description"](#).

>> END

C1166, C1167 SV SYSTEM

Description

INFOID:000000008457338

The suction valve supplies the brake fluid from the master cylinder to the pump, when VDC/TCS is activated.

DTC Logic

INFOID:000000008457339

DTC DETECTION LOGIC

DTC	Display item	Malfunction detected condition	Possible cause
C1166	SV1	Suction valve 1 (SV1) on the primary side is open circuit or shorted, or the control line is open or shorted to the power supply or the ground.	<ul style="list-style-type: none"> Harness or connector ABS actuator and electric unit (control unit)
C1167	SV2	Suction valve 2 (SV2) on the secondary side is open circuit or shorted, or the control line is open or shorted to the power supply or the ground.	

DTC CONFIRMATION PROCEDURE

1. PRECONDITIONING

If "DTC CONFIRMATION PROCEDURE" has been previously conducted, always turn the ignition switch OFF and wait at least 10 seconds before conducting the next test.

>> GO TO 2.

2. DTC REPRODUCTION PROCEDURE

1. Turn the ignition switch OFF to ON.
2. Perform self-diagnosis for "ABS" with CONSULT.

Is DTC "C1166" or "C1167" detected?

- YES >> Proceed to diagnosis procedure. Refer to [BRC-83, "Diagnosis Procedure"](#).
 NO >> INSPECTION END

Diagnosis Procedure

INFOID:000000008457340

1. CHECK CONNECTOR

1. Turn the ignition switch OFF.
2. Disconnect ABS actuator and electric unit (control unit) harness connector.
3. Check the terminal for deformation, disconnection, looseness, etc.

Is the inspection result normal?

- YES >> GO TO 2.
 NO >> Repair or replace error-detected parts.

2. CHECK SUCTION VALVE (SV) POWER SUPPLY

1. Check the voltage between ABS actuator and electric unit (control unit) harness connector and ground.

ABS actuator and electric unit (control unit)		—	Voltage (Approx.)
Connector	Terminal		
E36	1	Ground	Battery voltage

2. Turn the ignition switch ON.
CAUTION:
Never start the engine.
3. Check the voltage between ABS actuator and electric unit (control unit) harness connector and ground.

ABS actuator and electric unit (control unit)		—	Voltage (Approx.)
Connector	Terminal		
E36	1	Ground	Battery voltage

Is the inspection result normal?

- YES >> GO TO 4.
- NO >> GO TO 3.

3.CHECK SUCTION VALVE (SV) POWER SUPPLY CIRCUIT

1. Turn the ignition switch OFF.
2. Check the 20A fusible link (#G).
3. Check the continuity and short circuit between ABS actuator and electric unit (control unit) harness connector terminal (1) and 20A fusible link (#G).

Is the inspection result normal?

- YES >> Perform trouble diagnosis for battery power supply. Refer to [PG-6. "Wiring Diagram - BATTERY POWER SUPPLY -"](#).
- NO >> Repair or replace error-detected parts.

4.CHECK SUCTION VALVE (SV) GROUND CIRCUIT

Check the continuity between ABS actuator and electric unit (control unit) harness connector and ground.

ABS actuator and electric unit (control unit)		—	Continuity
Connector	Terminal		
E36	13	Ground	Existed
	26		

Is the inspection result normal?

- YES >> Replace ABS actuator and electric unit (control unit). Refer to [BRC-125. "Exploded View"](#).
- NO >> Repair or replace error-detected parts.

Special Repair Requirement

INFOID:000000008457341

1.AJUSTMENT OF STEERING ANGLE SENSOR NEUTRAL POSITION AND CALIBRATION OF DECEL G SENSOR

- After replacing an ABS actuator and electric unit (control unit), be sure to perform the following procedure.
 - Adjustment of steering angle sensor neutral position: Refer to [BRC-9. "ADJUSTMENT OF STEERING ANGLE SENSOR NEUTRAL POSITION : Description"](#).
 - Calibration of decel G sensor: Refer to [BRC-10. "CALIBRATION OF DECEL G SENSOR : Description"](#).
- After removing an ABS actuator and electric unit (control unit), be sure to perform the following procedure.
 - Calibration of decel G sensor: Refer to [BRC-10. "CALIBRATION OF DECEL G SENSOR : Description"](#).
- After removing/replacing a steering angle sensor, be sure to perform the following procedure.
 - Adjustment of steering angle sensor neutral position: Refer to [BRC-9. "ADJUSTMENT OF STEERING ANGLE SENSOR NEUTRAL POSITION : Description"](#).
- After removing/replacing a yaw rate/side/decel G sensor, be sure to perform the following procedure.
 - Calibration of decel G sensor: Refer to [BRC-10. "CALIBRATION OF DECEL G SENSOR : Description"](#).

>> END

U1000 CAN COMM CIRCUIT

Description

INFOID:000000008457342

CAN (Controller Area Network) is a serial communication line for real time application. It is an on-vehicle multiplex communication line with high data communication speed and excellent error detection ability. Many electronic control units are equipped onto a vehicle, and each control unit shares information and links with other control units during operation (not independent). In CAN communication, control units are connected with 2 communication lines (CAN-H line, CAN-L line) allowing a high rate of information transmission with less wiring. Each control unit transmits/receives data but selectively reads required data only.

DTC Logic

INFOID:000000008457343

DTC DETECTION LOGIC

DTC	Display item	Malfunction detected condition	Possible cause
U1000	CAN COMM CIRCUIT	When ABS actuator and electric unit (control unit) is not transmitting or receiving CAN communication signal for 2 seconds or more.	<ul style="list-style-type: none"> • Harness or connector • CAN communication line • ABS actuator and electric unit (control unit)

A
B
C
D
E
BRC

DTC CONFIRMATION PROCEDURE

1. PRECONDITIONING

If "DTC CONFIRMATION PROCEDURE" has been previously conducted, always turn the ignition switch OFF and wait at least 10 seconds before conducting the next test.

>> GO TO 2.

2. DTC REPRODUCTION PROCEDURE

1. Turn the ignition switch OFF to ON.
2. Perform self-diagnosis for "ABS" with CONSULT.

Is DTC "U1000" detected?

- YES >> Proceed to diagnosis procedure. Refer to [BRC-85, "Diagnosis Procedure"](#).
- NO >> INSPECTION END

Diagnosis Procedure

INFOID:000000008457344

1. PERFORM SELF-DIAGNOSIS

Perform self-diagnosis for "ABS" with CONSULT.

Is DTC "U1000" detected?

- YES >> Proceed to [LAN-18, "Trouble Diagnosis Flow Chart"](#).
- NO >> INSPECTION END

Special Repair Requirement

INFOID:000000008457345

1. ADJUSTMENT OF STEERING ANGLE SENSOR NEUTRAL POSITION AND CALIBRATION OF DECEL G SENSOR

- After replacing an ABS actuator and electric unit (control unit), be sure to perform the following procedure.
 - Adjustment of steering angle sensor neutral position: Refer to [BRC-9, "ADJUSTMENT OF STEERING ANGLE SENSOR NEUTRAL POSITION : Description"](#).
 - Calibration of decel G sensor: Refer to [BRC-10, "CALIBRATION OF DECEL G SENSOR : Description"](#).
- After removing an ABS actuator and electric unit (control unit), be sure to perform the following procedure.
 - Calibration of decel G sensor: Refer to [BRC-10, "CALIBRATION OF DECEL G SENSOR : Description"](#).
- After removing/replacing a steering angle sensor, be sure to perform the following procedure.
 - Adjustment of steering angle sensor neutral position: Refer to [BRC-9, "ADJUSTMENT OF STEERING ANGLE SENSOR NEUTRAL POSITION : Description"](#).
- After removing/replacing a yaw rate/side/decel G sensor, be sure to perform the following procedure.
 - Calibration of decel G sensor: Refer to [BRC-10, "CALIBRATION OF DECEL G SENSOR : Description"](#).

G
H
I
J
K
L
M
N
O

U1000 CAN COMM CIRCUIT

< DTC/CIRCUIT DIAGNOSIS >

[VDC/TCS/ABS]

>> END

U1002 SYSTEM COMM (CAN)

Description

INFOID:000000008457346

CAN (Controller Area Network) is a serial communication line for real time application. It is an on-vehicle multiplex communication line with high data communication speed and excellent error detection ability. Many electronic control units are equipped onto a vehicle, and each control unit shares information and links with other control units during operation (not independent). In CAN communication, control units are connected with 2 communication lines (CAN-H line, CAN-L line) allowing a high rate of information transmission with less wiring. Each control unit transmits/receives data but selectively reads required data only.

DTC Logic

INFOID:000000008457347

DTC DETECTION LOGIC

DTC	Display item	Malfunction detected condition	Possible cause
U1002	SYSTEM COMM (CAN)	When ABS actuator and electric unit (control unit) is not transmitting or receiving CAN communication signal of steering angle sensor for 2 seconds or less.	<ul style="list-style-type: none"> • Harness or connector • CAN communication line • ABS actuator and electric unit (control unit)

A
B
C
D
E
BRC

DTC CONFIRMATION PROCEDURE

1. PRECONDITIONING

If "DTC CONFIRMATION PROCEDURE" has been previously conducted, always turn the ignition switch OFF and wait at least 10 seconds before conducting the next test.

>> GO TO 2.

2. DTC REPRODUCTION PROCEDURE

1. Turn the ignition switch OFF to ON.
2. Perform self-diagnosis for "ABS" with CONSULT.

Is DTC "U1002" detected?

- YES >> Proceed to diagnosis procedure. Refer to [BRC-87, "Diagnosis Procedure"](#).
 NO >> INSPECTION END

Diagnosis Procedure

INFOID:000000008457348

CAUTION:

- **Never apply 7.0 V or more to the measurement terminal.**
- **Use a tester with open terminal voltage of 7.0 V or less.**
- **Turn the ignition switch OFF and disconnect the battery cable from the negative terminal when checking the harness.**

1. CHECK CAN DIAGNOSIS SUPPORT MONITOR

1. Select "ABS" and "CAN Diagnosis Support Monitor" in order with CONSULT.
2. Check the malfunction history between each control unit connected to ABS actuator and electric unit (control unit).

Check the result of "PAST"

All items are "OK">>Refer to [GI-45, "Intermittent Incident"](#).
 "TRANSMIT DIAG" is other than "OK">>GO TO 2.

A control unit other than ABS actuator and electric unit (control unit) is anything other than "OK">>GO TO 3.

2. CHECK TRANSMITTING SIDE UNIT

Check the ABS actuator and electric unit (control unit) harness connector terminals No. 21 and 23 for damage or loose connection.

Is the inspection result normal?

- YES >> Erase self-diagnosis results. Then perform self-diagnosis for "ABS" with CONSULT.

G
H
I
J
K
L
M
N
O
P

U1002 SYSTEM COMM (CAN)

[VDC/TCS/ABS]

< DTC/CIRCUIT DIAGNOSIS >

NO >> Recheck the terminals for damage or loose connection. Refer to [LAN-8. "Precautions for Harness Repair"](#).

3.CHECK APPLICABLE CONTROL UNIT

Check the damage or loose connection of each CAN communication line harness connector terminals.

Is the inspection result normal?

YES >> Erase self-diagnosis results. Then perform self-diagnosis for applicable control unit with CONSULT.

NO >> Recheck the terminals for damage or loose connection. Refer to [LAN-8. "Precautions for Harness Repair"](#).

Special Repair Requirement

INFOID:000000008457349

1.AJUSTMENT OF STEERING ANGLE SENSOR NEUTRAL POSITION AND CALIBRATION OF DECEL G SENSOR

- After replacing an ABS actuator and electric unit (control unit), be sure to perform the following procedure.
- Adjustment of steering angle sensor neutral position: Refer to [BRC-9. "ADJUSTMENT OF STEERING ANGLE SENSOR NEUTRAL POSITION : Description"](#).
- Calibration of decel G sensor: Refer to [BRC-10. "CALIBRATION OF DECEL G SENSOR : Description"](#).
- After removing an ABS actuator and electric unit (control unit), be sure to perform the following procedure.
- Calibration of decel G sensor: Refer to [BRC-10. "CALIBRATION OF DECEL G SENSOR : Description"](#).
- After removing/replacing a steering angle sensor, be sure to perform the following procedure.
- Adjustment of steering angle sensor neutral position: Refer to [BRC-9. "ADJUSTMENT OF STEERING ANGLE SENSOR NEUTRAL POSITION : Description"](#).
- After removing/replacing a yaw rate/side/decel G sensor, be sure to perform the following procedure.
- Calibration of decel G sensor: Refer to [BRC-10. "CALIBRATION OF DECEL G SENSOR : Description"](#).

>> END

POWER SUPPLY AND GROUND CIRCUIT

< DTC/CIRCUIT DIAGNOSIS >

[VDC/TCS/ABS]

POWER SUPPLY AND GROUND CIRCUIT

Description

INFOID:000000008457350

Supplies power to ABS actuator and electric unit (control unit).

Diagnosis Procedure

INFOID:000000008457351

1. CHECK ABS ACTUATOR AND ELECTRIC UNIT (CONTROL UNIT) IGNITION POWER SUPPLY

1. Turn the ignition switch OFF.
2. Disconnect ABS actuator and electric unit (control unit) harness connector.
3. Check the voltage between ABS actuator and electric unit (control unit) harness connector and ground.

ABS actuator and electric unit (control unit)		—	Voltage (Approx.)
Connector	Terminal		
E36	20	Ground	0 V

4. Turn the ignition switch ON.
CAUTION:
Never start the engine.
5. Check the voltage between ABS actuator and electric unit (control unit) harness connector and ground.

ABS actuator and electric unit (control unit)		—	Voltage (Approx.)
Connector	Terminal		
E36	20	Ground	Battery voltage

Is the inspection result normal?

- YES >> GO TO 3.
NO >> GO TO 2.

2. CHECK ABS ACTUATOR AND ELECTRIC UNIT (CONTROL UNIT) IGNITION POWER SUPPLY CIRCUIT

1. Turn the ignition switch OFF.
2. Check the 10A fuse (#45).
3. Disconnect IPDM E/R harness connector.
4. Check the continuity between ABS actuator and electric unit (control unit) harness connector and IPDM E/R harness connector.

ABS actuator and electric unit (control unit)		IPDM E/R		Continuity
Connector	Terminal	Connector	Terminal	
E36	20	E10	25	Existed

Is the inspection result normal?

- YES >> Perform trouble diagnosis for ignition power supply. Refer to [PG-21, "Wiring Diagram - IGNITION POWER SUPPLY -"](#).
- NO >> Repair or replace error-detected parts.

3. CHECK ABS ACTUATOR AND ELECTRIC UNIT (CONTROL UNIT) BATTERY POWER SUPPLY

1. Turn the ignition switch OFF.
2. Check the voltage between ABS actuator and electric unit (control unit) harness connector and ground.

A

B

C

D

E

BRC

G

H

I

J

K

L

M

N

O

P

POWER SUPPLY AND GROUND CIRCUIT

< DTC/CIRCUIT DIAGNOSIS >

[VDC/TCS/ABS]

ABS actuator and electric unit (control unit)		—	Voltage (Approx.)
Connector	Terminal		
E36	1	Ground	Battery voltage
	14		

3. Turn the ignition switch ON.

CAUTION:

Never start the engine.

4. Check the voltage between ABS actuator and electric unit (control unit) harness connector and ground.

ABS actuator and electric unit (control unit)		—	Voltage (Approx.)
Connector	Terminal		
E36	1	Ground	Battery voltage
	14		

Is the inspection result normal?

YES >> GO TO 5.

NO >> GO TO 4.

4. CHECK ABS ACTUATOR AND ELECTRIC UNIT (CONTROL UNIT) BATTERY POWER SUPPLY CIRCUIT

1. Turn the ignition switch OFF.
2. Check the 20A fusible link (#G) and 30A fusible link (#F).
3. Check the continuity and short circuit between ABS actuator and electric unit (control unit) harness connector terminal (1) and 20A fusible link (#G).
4. Check the continuity and short circuit between ABS actuator and electric unit (control unit) harness connector terminal (14) and 30A fusible link (#F).

Is the inspection result normal?

YES >> Perform trouble diagnosis for battery power supply. Refer to [PG-6. "Wiring Diagram - BATTERY POWER SUPPLY -"](#).

NO >> Repair or replace error-detected parts.

5. CHECK ABS ACTUATOR AND ELECTRIC UNIT (CONTROL UNIT) GROUND CIRCUIT

1. Turn the ignition switch OFF.
2. Check the continuity between ABS actuator and electric unit (control unit) harness connector and ground.

ABS actuator and electric unit (control unit)		—	Continuity
Connector	Terminal		
E36	13	Ground	Existed
	26		

Is the inspection result normal?

YES >> INSPECTION END

NO >> Repair or replace error-detected parts.

Special Repair Requirement

INFOID:0000000008457352

1. ADJUSTMENT OF STEERING ANGLE SENSOR NEUTRAL POSITION AND CALIBRATION OF DECEL G SENSOR

- After replacing an ABS actuator and electric unit (control unit), be sure to perform the following procedure.
 - Adjustment of steering angle sensor neutral position: Refer to [BRC-9. "ADJUSTMENT OF STEERING ANGLE SENSOR NEUTRAL POSITION : Description"](#).
 - Calibration of decel G sensor: Refer to [BRC-10. "CALIBRATION OF DECEL G SENSOR : Description"](#).
- After removing an ABS actuator and electric unit (control unit), be sure to perform the following procedure.

POWER SUPPLY AND GROUND CIRCUIT

< DTC/CIRCUIT DIAGNOSIS >

[VDC/TCS/ABS]

- Calibration of decel G sensor: Refer to [BRC-10. "CALIBRATION OF DECEL G SENSOR : Description"](#).
- After removing/replacing a steering angle sensor, be sure to perform the following procedure.
- Adjustment of steering angle sensor neutral position: Refer to [BRC-9. "ADJUSTMENT OF STEERING ANGLE SENSOR NEUTRAL POSITION : Description"](#).
- After removing/replacing a yaw rate/side/decel G sensor, be sure to perform the following procedure.
- Calibration of decel G sensor: Refer to [BRC-10. "CALIBRATION OF DECEL G SENSOR : Description"](#).

>> END

A
B
C
D
E
G
H
I
J
K
L
M
N
O
P

BRC

PARKING BRAKE SWITCH

< DTC/CIRCUIT DIAGNOSIS >

[VDC/TCS/ABS]

PARKING BRAKE SWITCH

Component Function Check

INFOID:000000008457353

1. CHECK PARKING BRAKE SWITCH OPERATION

Operate the parking brake pedal. Then check that the brake warning lamp in the combination meter turns ON/OFF correctly.

Condition	Brake warning lamp illumination status
When the parking brake pedal is operation	ON
When the parking brake pedal is not operation.	OFF

Is the inspection result normal?

YES >> INSPECTION END

NO >> Proceed to diagnosis procedure. Refer to [BRC-92, "Diagnosis Procedure"](#).

Diagnosis Procedure

INFOID:000000008457354

1. CHECK PARKING BRAKE SWITCH

Check the parking brake switch. Refer to [BRC-92, "Component Inspection"](#).

Is the inspection result normal?

YES >> GO TO 2.

NO >> Replace parking brake switch. Refer to [PB-6, "Exploded View"](#).

2. CHECK COMBINATION METER

Check the indication and operation of combination meter are normal. Refer to [MWI-34, "Diagnosis Description"](#).

Is the inspection result normal?

YES >> GO TO 3.

NO >> Check the combination meter. Refer to [MWI-35, "CONSULT Function \(METER/M&A\)"](#).

3. CHECK PARKING BRAKE SWITCH CIRCUIT

1. Turn the ignition switch OFF.
2. Disconnect parking brake switch harness connector.
3. Disconnect combination meter harness connector.
4. Check the continuity between parking brake switch harness connector and combination meter harness connector.

Parking brake switch		Combination meter		Continuity
Connector	Terminal	Connector	Terminal	
E27	1	M34	26	Existed

Is the inspection result normal?

YES >> INSPECTION END

NO >> Repair or replace error-detected parts.

Component Inspection

INFOID:000000008457355

1. CHECK PARKING BRAKE SWITCH

1. Turn the ignition switch OFF.
2. Disconnect parking brake switch harness connector.
3. Check the continuity between parking brake switch connector terminal and ground.

PARKING BRAKE SWITCH

< DTC/CIRCUIT DIAGNOSIS >

[VDC/TCS/ABS]

Parking brake switch		—	Condition	Continuity
Connector	Terminal			
E27	1	Ground	When the parking brake switch is operated.	Existed
			When the parking brake switch is not operated.	Not existed

Is the inspection result normal?

YES >> INSPECTION END

NO >> Replace parking brake switch. Refer to [PB-6. "Exploded View"](#).

A
B
C
D
E
G
H
I
J
K
L
M
N
O
P

BRC

VDC OFF SWITCH

< DTC/CIRCUIT DIAGNOSIS >

[VDC/TCS/ABS]

VDC OFF SWITCH

Description

INFOID:000000008457356

VDC OFF switch can deactivate (turn OFF) the VDC/TCS function by pressing the VDC OFF switch.

Component Function Check

INFOID:000000008457357

1.CHECK VDC OFF SWITCH OPERATION

Turn ON/OFF the VDC OFF switch and check that the VDC OFF indicator lamp in the combination meter turns ON/OFF correctly.

Is the inspection result normal?

YES >> INSPECTION END

NO >> Proceed to diagnosis procedure. Refer to [BRC-94, "Diagnosis Procedure"](#).

Diagnosis Procedure

INFOID:000000008457358

1.CHECK VDC OFF SWITCH

Check the VDC OFF switch. Refer to [BRC-95, "Component Inspection"](#).

Is the inspection result normal?

YES >> GO TO 2.

NO >> Replace VDC OFF switch. Refer to [BRC-129, "Removal and Installation"](#).

2.CHECK VDC OFF SWITCH HARNESS

1. Disconnect ABS actuator and electric unit (control unit) harness connector.
2. Disconnect VDC OFF switch harness connector.
3. Check the continuity between VDC OFF switch harness connector and ABS actuator and electric unit (control unit) harness connector.

ABS actuator and electric unit (control unit)		VDC OFF switch		Continuity
Connector	Terminal	Connector	Terminal	
E36	22	M5	1	Existed

4. Check the continuity between ABS actuator and electric unit (control unit) harness connector and ground.

ABS actuator and electric unit (control unit)		—	Continuity
Connector	Terminal		
E36	22	Ground	Not existed

5. Check the continuity between VDC OFF switch harness connector and ground.

VDC OFF switch		—	Continuity
Connector	Terminal		
M5	2	Ground	Existed

Is the inspection result normal?

YES >> GO TO 3.

NO >> Repair or replace error-detected parts.

3.CHECK COMBINATION METER

1. Connect ABS actuator and electric unit (control unit) harness connector.
2. Connect VDC OFF switch harness connector.
3. Check the indication and operation of combination meter are normal. Refer to [MWI-34, "Diagnosis Description"](#).

Is the inspection result normal?

YES >> INSPECTION END

VDC OFF SWITCH

[VDC/TCS/ABS]

< DTC/CIRCUIT DIAGNOSIS >

NO >> Repair or replace combination meter.

Component Inspection

INFOID:000000008457359

1. CHECK VDC OFF SWITCH

1. Turn the ignition switch OFF.
2. Disconnect VDC OFF switch harness connector.
3. Check the continuity between VDC OFF switch connector terminals.

VDC OFF switch	Condition	Condition
Terminal		
1 - 2	When VDC OFF switch is hold pressed.	Existed
	When releasing VDC OFF switch.	Not existed

Is the inspection result normal?

YES >> INSPECTION END

NO >> Replace VDC OFF switch. Refer to [BRC-129. "Removal and Installation"](#).

Special Repair Requirement

INFOID:000000008457360

1. ADJUSTMENT OF STEERING ANGLE SENSOR NEUTRAL POSITION AND CALIBRATION OF DECEL G SENSOR

- After replacing an ABS actuator and electric unit (control unit), be sure to perform the following procedure.
- Adjustment of steering angle sensor neutral position: Refer to [BRC-9. "ADJUSTMENT OF STEERING ANGLE SENSOR NEUTRAL POSITION : Description"](#).
- Calibration of decel G sensor: Refer to [BRC-10. "CALIBRATION OF DECEL G SENSOR : Description"](#).
- After removing an ABS actuator and electric unit (control unit), be sure to perform the following procedure.
- Calibration of decel G sensor: Refer to [BRC-10. "CALIBRATION OF DECEL G SENSOR : Description"](#).
- After removing/replacing a steering angle sensor, be sure to perform the following procedure.
- Adjustment of steering angle sensor neutral position: Refer to [BRC-9. "ADJUSTMENT OF STEERING ANGLE SENSOR NEUTRAL POSITION : Description"](#).
- After removing/replacing a yaw rate/side/decel G sensor, be sure to perform the following procedure.
- Calibration of decel G sensor: Refer to [BRC-10. "CALIBRATION OF DECEL G SENSOR : Description"](#).

>> END

ABS WARNING LAMP

[VDC/TCS/ABS]

< DTC/CIRCUIT DIAGNOSIS >

ABS WARNING LAMP

Description

INFOID:000000008457361

×: ON –: OFF

Condition	ABS warning lamp
Ignition switch OFF	–
For 2 seconds after turning ignition switch ON	×
2 seconds later after turning ignition switch ON (system is normal)	–
ABS function is malfunctioning.	×
EBD function is malfunctioning.	×

Component Function Check

INFOID:000000008457362

1. CHECK ABS WARNING LAMP OPERATION

Check that the lamp illuminates for approximately 2 seconds after the ignition switch is turned ON.

Is the inspection result normal?

YES >> INSPECTION END

NO >> Proceed to diagnosis procedure. Refer to [BRC-96, "Diagnosis Procedure"](#).

Diagnosis Procedure

INFOID:000000008457363

1. PERFORM SELF-DIAGNOSIS

Perform self-diagnosis for "ABS" with CONSULT.

Is the inspection result normal?

YES >> Check the combination meter. Refer to [MWI-35, "CONSULT Function \(METER/M&A\)"](#).

NO >> Check items displayed by self-diagnosis for "ABS" with CONSULT.

Special Repair Requirement

INFOID:000000008457364

1. ADJUSTMENT OF STEERING ANGLE SENSOR NEUTRAL POSITION AND CALIBRATION OF DECEL G SENSOR

- After replacing an ABS actuator and electric unit (control unit), be sure to perform the following procedure.
- Adjustment of steering angle sensor neutral position: Refer to [BRC-9, "ADJUSTMENT OF STEERING ANGLE SENSOR NEUTRAL POSITION : Description"](#).
- Calibration of decel G sensor: Refer to [BRC-10, "CALIBRATION OF DECEL G SENSOR : Description"](#).
- After removing an ABS actuator and electric unit (control unit), be sure to perform the following procedure.
- Calibration of decel G sensor: Refer to [BRC-10, "CALIBRATION OF DECEL G SENSOR : Description"](#).
- After removing/replacing a steering angle sensor, be sure to perform the following procedure.
- Adjustment of steering angle sensor neutral position: Refer to [BRC-9, "ADJUSTMENT OF STEERING ANGLE SENSOR NEUTRAL POSITION : Description"](#).
- After removing/replacing a yaw rate/side/decel G sensor, be sure to perform the following procedure.
- Calibration of decel G sensor: Refer to [BRC-10, "CALIBRATION OF DECEL G SENSOR : Description"](#).

>> END

BRAKE WARNING LAMP

Description

INFOID:000000008457365

×: ON –: OFF

Condition	Brake warning lamp (Note 1)
Ignition switch OFF	–
For 2 seconds after turning ignition switch ON	× (Note 2)
2 seconds later after turning ignition switch ON (system is normal)	× (Note 2)
ABS function is malfunctioning.	–
EBD function is malfunctioning.	×

NOTE:

- 1: Brake warning lamp will turn ON in case of parking brake operation (when switch is ON) or of brake fluid level switch operation (when brake fluid is insufficient).
- 2: After starting the engine, brake warning lamp is turned off.

Component Function Check

INFOID:000000008457366

1. BRAKE WARNING LAMP OPERATION CHECK 1

Check that the lamp illuminates for approximately 2 seconds after the ignition switch is turned ON.

Is the inspection result normal?

YES >> GO TO 2.

NO >> Proceed to diagnosis procedure. Refer to [BRC-97. "Diagnosis Procedure"](#).

2. BRAKE WARNING LAMP OPERATION CHECK 2

Check that the brake warning lamp in the combination meter turns ON/OFF correctly when operating the parking brake pedal.

NOTE:

Brake warning lamp will turn ON in case of parking brake operation (when switch is ON) or of brake fluid level switch operation (when brake fluid is insufficient).

Is the inspection result normal?

YES >> INSPECTION END

NO >> Check the parking brake switch. Refer to [BRC-92. "Diagnosis Procedure"](#).

Diagnosis Procedure

INFOID:000000008457367

1. CHECK PARKING BRAKE SWITCH

Check that the brake warning lamp in the combination meter turns ON/OFF correctly when operating the parking brake pedal.

NOTE:

Brake warning lamp will turn ON in case of parking brake operation (when switch is ON) or of brake fluid level switch operation (when brake fluid is insufficient).

Is the inspection result normal?

YES >> GO TO 2.

NO >> Check the parking brake switch. Refer to [BRC-92. "Diagnosis Procedure"](#).

2. PERFORM SELF-DIAGNOSIS

Perform self-diagnosis for "ABS" with CONSULT.

Is the inspection result normal?

YES >> Check the combination meter. Refer to [MWI-35. "CONSULT Function \(METER/M&A\)"](#).

NO >> Check items displayed by self-diagnosis for "ABS" with CONSULT.

Special Repair Requirement

INFOID:000000008457368

1. ADJUSTMENT OF STEERING ANGLE SENSOR NEUTRAL POSITION AND CALIBRATION OF DECEL G

BRAKE WARNING LAMP

< DTC/CIRCUIT DIAGNOSIS >

[VDC/TCS/ABS]

SENSOR

- After replacing an ABS actuator and electric unit (control unit), be sure to perform the following procedure.
- Adjustment of steering angle sensor neutral position: Refer to [BRC-9, "ADJUSTMENT OF STEERING ANGLE SENSOR NEUTRAL POSITION : Description"](#).
- Calibration of decel G sensor: Refer to [BRC-10, "CALIBRATION OF DECEL G SENSOR : Description"](#).
- After removing an ABS actuator and electric unit (control unit), be sure to perform the following procedure.
- Calibration of decel G sensor: Refer to [BRC-10, "CALIBRATION OF DECEL G SENSOR : Description"](#).
- After removing/replacing a steering angle sensor, be sure to perform the following procedure.
- Adjustment of steering angle sensor neutral position: Refer to [BRC-9, "ADJUSTMENT OF STEERING ANGLE SENSOR NEUTRAL POSITION : Description"](#).
- After removing/replacing a yaw rate/side/decel G sensor, be sure to perform the following procedure.
- Calibration of decel G sensor: Refer to [BRC-10, "CALIBRATION OF DECEL G SENSOR : Description"](#).

>> END

VDC WARNING LAMP

< DTC/CIRCUIT DIAGNOSIS >

[VDC/TCS/ABS]

VDC WARNING LAMP

Description

INFOID:000000008457369

×: ON Δ: Blink -: OFF

Condition	VDC warning lamp
Ignition switch OFF	-
For 2 seconds after turning ignition switch ON	×
2 seconds later after turning ignition switch ON	-
VDC/TCS is activated while driving.	Δ
VDC/TCS function is malfunctioning.	×
ABS function is malfunctioning.	×
EBD function is malfunctioning.	×

Component Function Check

INFOID:000000008457370

1. CHECK VDC WARNING LAMP OPERATION

Check that the lamp illuminates for approximately 2 seconds after the ignition switch is turned ON.

Is the inspection result normal?

YES >> INSPECTION END

NO >> Proceed to diagnosis procedure. Refer to [BRC-99, "Diagnosis Procedure"](#).

Diagnosis Procedure

INFOID:000000008457371

1. PERFORM SELF-DIAGNOSIS

Perform self-diagnosis for "ABS" with CONSULT.

Is the inspection result normal?

YES >> Check the combination meter. Refer to [MWI-35, "CONSULT Function \(METER/M&A\)"](#).

NO >> Check items displayed by self-diagnosis for "ABS" with CONSULT.

Special Repair Requirement

INFOID:000000008457372

1. ADJUSTMENT OF STEERING ANGLE SENSOR NEUTRAL POSITION AND CALIBRATION OF DECEL G SENSOR

- After replacing an ABS actuator and electric unit (control unit), be sure to perform the following procedure.
- Adjustment of steering angle sensor neutral position: Refer to [BRC-9, "ADJUSTMENT OF STEERING ANGLE SENSOR NEUTRAL POSITION : Description"](#).
- Calibration of decel G sensor: Refer to [BRC-10, "CALIBRATION OF DECEL G SENSOR : Description"](#).
- After removing an ABS actuator and electric unit (control unit), be sure to perform the following procedure.
- Calibration of decel G sensor: Refer to [BRC-10, "CALIBRATION OF DECEL G SENSOR : Description"](#).
- After removing/replacing a steering angle sensor, be sure to perform the following procedure.
- Adjustment of steering angle sensor neutral position: Refer to [BRC-9, "ADJUSTMENT OF STEERING ANGLE SENSOR NEUTRAL POSITION : Description"](#).
- After removing/replacing a yaw rate/side/decel G sensor, be sure to perform the following procedure.
- Calibration of decel G sensor: Refer to [BRC-10, "CALIBRATION OF DECEL G SENSOR : Description"](#).

>> END

VDC OFF INDICATOR LAMP

< DTC/CIRCUIT DIAGNOSIS >

[VDC/TCS/ABS]

VDC OFF INDICATOR LAMP

Description

INFOID:000000008457373

×: ON –: OFF

Condition	VDC OFF indicator lamp
Ignition switch OFF	–
For 2 seconds after turning ignition switch ON	×
2 seconds later after turning ignition switch ON	–
VDC OFF switch turned ON. (VDC function is OFF.)	×
VDC/TCS function is malfunctioning.	–
ABS function is malfunctioning.	–
EBD function is malfunctioning.	–

Component Function Check

INFOID:000000008457374

1. VDC OFF INDICATOR LAMP OPERATION CHECK 1

Check that the lamp illuminates for approximately 2 seconds after the ignition switch is turned ON.

Is the inspection result normal?

YES >> GO TO 2.

NO >> Proceed to diagnosis procedure. Refer to [BRC-100, "Diagnosis Procedure"](#).

2. VDC OFF INDICATOR LAMP OPERATION CHECK 2

Check that the VDC OFF indicator lamp in the combination meter turns ON/OFF correctly when operating the VDC OFF switch.

Is the inspection result normal?

YES >> INSPECTION END

NO >> Check the VDC OFF switch. Refer to [BRC-94, "Diagnosis Procedure"](#).

Diagnosis Procedure

INFOID:000000008457375

1. CHECK ABS ACTUATOR AND ELECTRIC UNIT (CONTROL UNIT) POWER SUPPLY AND GROUND CIRCUIT

Perform diagnosis of ABS actuator and electric unit (control unit) power supply and ground circuit. Refer to [BRC-89, "Diagnosis Procedure"](#).

Is the inspection result normal?

YES >> GO TO 2.

NO >> Repair or replace error-detected parts.

2. CHECK VDC OFF INDICATOR LAMP SIGNAL (1)

1. Select "ABS", "DATA MONITOR" and "OFF LAMP" according to this order with CONSULT.
2. Turn the ignition switch OFF.
3. Check that data monitor displays "On" for approx. 1 second after ignition switch is turned ON, and then changes to "Off".

CAUTION:

Never start engine.

Is the inspection result normal?

YES >> GO TO 3.

NO >> Replace ABS actuator and electric unit (control unit). Refer to [BRC-125, "Exploded View"](#).

3. CHECK VDC OFF INDICATOR LAMP SIGNAL (2)

1. Select "ABS", "DATA MONITOR" and "OFF LAMP" according to this order with CONSULT.
2. Check that data monitor displays "On" or "Off" each time when VDC OFF switch is operated.

Is the inspection result normal?

YES >> Check the combination meter. Refer to [MWI-34, "Diagnosis Description"](#).

VDC OFF INDICATOR LAMP

< DTC/CIRCUIT DIAGNOSIS >

[VDC/TCS/ABS]

NO >> Check the VDC OFF switch system. Refer to [BRC-94. "Diagnosis Procedure"](#).

Special Repair Requirement

INFOID:000000008457376

1. ADJUSTMENT OF STEERING ANGLE SENSOR NEUTRAL POSITION AND CALIBRATION OF DECEL G SENSOR

- After replacing an ABS actuator and electric unit (control unit), be sure to perform the following procedure.
- Adjustment of steering angle sensor neutral position: Refer to [BRC-9. "ADJUSTMENT OF STEERING ANGLE SENSOR NEUTRAL POSITION : Description"](#).
- Calibration of decel G sensor: Refer to [BRC-10. "CALIBRATION OF DECEL G SENSOR : Description"](#).
- After removing an ABS actuator and electric unit (control unit), be sure to perform the following procedure.
- Calibration of decel G sensor: Refer to [BRC-10. "CALIBRATION OF DECEL G SENSOR : Description"](#).
- After removing/replacing a steering angle sensor, be sure to perform the following procedure.
- Adjustment of steering angle sensor neutral position: Refer to [BRC-9. "ADJUSTMENT OF STEERING ANGLE SENSOR NEUTRAL POSITION : Description"](#).
- After removing/replacing a yaw rate/side/decel G sensor, be sure to perform the following procedure.
- Calibration of decel G sensor: Refer to [BRC-10. "CALIBRATION OF DECEL G SENSOR : Description"](#).

>> END

A
B
C
D
E
G
H
I
J
K
L
M
N
O
P

BRC

ABS ACTUATOR AND ELECTRIC UNIT (CONTROL UNIT)

< ECU DIAGNOSIS INFORMATION >

[VDC/TCS/ABS]

ECU DIAGNOSIS INFORMATION

ABS ACTUATOR AND ELECTRIC UNIT (CONTROL UNIT)

Reference Value

INFOID:000000008457377

VALUES ON THE DIAGNOSIS TOOL

CAUTION:

The display shows the control unit calculation data, so a normal value might be displayed even in the event the output circuit (harness) is open or short-circuited.

NOTE:

The following table includes information (items) inapplicable to this vehicle. For information (items) applicable to this vehicle, refer to CONSULT display items.

Monitor item	Display content	Data monitor	
		Condition	Reference value in normal operation
FR LH SENSOR	Wheel speed	Vehicle stopped	0 [km/h (MPH)]
		Vehicle running (Note 1)	Nearly matches the speedometer display (\pm 10% or less)
FR RH SENSOR	Wheel speed	Vehicle stopped	0 [km/h (MPH)]
		Vehicle running (Note 1)	Nearly matches the speedometer display (\pm 10% or less)
RR LH SENSOR	Wheel speed	Vehicle stopped	0 [km/h (MPH)]
		Vehicle running (Note 1)	Nearly matches the speedometer display (\pm 10% or less)
RR RH SENSOR	Wheel speed	Vehicle stopped	0 [km/h (MPH)]
		Vehicle running (Note 1)	Nearly matches the speedometer display (\pm 10% or less)
STOP LAMP SW	Brake pedal operation	When brake pedal is depressed	On
		When brake pedal is not depressed	Off
BATTERY VOLT	Battery voltage supplied to the ABS actuator and electric unit (control unit)	Ignition switch ON	10 – 16 V
GEAR	Gear position	Vehicle running	1 – 6
R POSI SIG	Select shift position	CVT shift position (R)	On
		CVT shift position (other R)	Off
N POSI SIG	Select shift position	CVT shift position (N)	On
		CVT shift position (other N)	Off
P POSI SIG	Select shift position	CVT shift position (P)	On
		CVT shift position (other P)	Off
SLCT LVR POSI	Select shift position	CVT shift position (P, R, N, D, L)	P R N D L
		Manual mode	##
OFF SW	VDC OFF switch ON/OFF status	VDC OFF switch ON (When VDC OFF indicator lamp is ON)	On
		VDC OFF switch OFF (When VDC OFF indicator lamp is OFF)	Off

ABS ACTUATOR AND ELECTRIC UNIT (CONTROL UNIT)

< ECU DIAGNOSIS INFORMATION >

[VDC/TCS/ABS]

Monitor item	Display content	Data monitor	
		Condition	Reference value in normal operation
YAW RATE SEN	Yaw rate detected by yaw rate/side/decel sensor	Vehicle stopped	Approx. 0 d/s
		Vehicle running	-100 to 100 d/s
DECEL G-SEN	Decel G detected by yaw rate/side/decel G sensor	Vehicle stopped	Approx. 0 G
		Vehicle running	-1.7 – +1.7 G
ACCEL POS SIG	Open/Close condition of throttle valve (Linked with accelerator pedal)	Accelerator pedal not depressed (Engine stopped)	0 %
		Depress accelerator pedal (Engine stopped)	0 - 100 %
SIDE G-SENSOR	Transverse G detected by yaw rate/side/decel G sensor	Vehicle stopped	Approx. 0 m/s ²
		Vehicle running	- 16.7 – 16.7 m/s ²
STR ANGLE SIG	Steering angle detected by steering angle sensor	Driving straight	-3.5 – +3.5°
		Turn 90 ° to left	Approx. -90 °
		Turn 90 ° to right	Approx. +90 °
ENGINE RPM	With engine running	With engine stopped	0 [tr/min (rpm)]
		Engine running	Almost in accordance with tachometer display
FLUID LEV SW	Brake fluid level switch signal status	When brake fluid level switch ON	On
		When brake fluid level switch OFF	Off
PRESS SENSOR	Brake fluid pressure detected by pressure sensor	With ignition switch ON and brake pedal released	Approx. 0 bar
		With ignition switch ON and brake pedal depressed	0 – 170 bar
FR RH IN SOL (Note 2)	Operation status of front RH ABS IN valve	Actuator (ABS IN valve) is active ("ACTIVE TEST" in "ABS" with CONSULT)	On
		When the actuator (ABS IN valve) is not active and actuator relay is active (ignition switch ON)	Off
FR RH OUT SOL (Note 2)	Operation status of front RH ABS OUT valve	Actuator (ABS OUT valve) is active ("ACTIVE TEST" in "ABS" with CONSULT)	On
		When the actuator (ABS OUT valve) is not active and actuator relay is active (ignition switch ON)	Off
FR LH IN SOL (Note 2)	Operation status of front LH ABS IN valve	Actuator (ABS IN valve) is active ("ACTIVE TEST" in "ABS" with CONSULT)	On
		When the actuator (ABS IN valve) is not active and actuator relay is active (ignition switch ON)	Off
FR LH OUT SOL (Note 2)	Operation status of front LH ABS OUT valve	Actuator (ABS OUT valve) is active ("ACTIVE TEST" in "ABS" with CONSULT)	On
		When the actuator (ABS OUT valve) is not active and actuator relay is active (ignition switch ON)	Off
RR RH IN SOL (Note 2)	Operation status of rear RH ABS IN valve	Actuator (ABS IN valve) is active ("ACTIVE TEST" in "ABS" with CONSULT)	On
		When the actuator (ABS IN valve) is not active and actuator relay is active (ignition switch ON)	Off

A
B
C
D
E
BRC
G
H
I
J
K
L
M
N
O
P

ABS ACTUATOR AND ELECTRIC UNIT (CONTROL UNIT)

< ECU DIAGNOSIS INFORMATION >

[VDC/TCS/ABS]

Monitor item	Display content	Data monitor	
		Condition	Reference value in normal operation
RR RH OUT SOL (Note 2)	Operation status of rear RH ABS OUT valve	Actuator (ABS OUT valve) is active ("ACTIVE TEST" in "ABS" with CONSULT)	On
		When the actuator (ABS OUT valve) is not active and actuator relay is active (ignition switch ON)	Off
RR LH IN SOL (Note 2)	Operation status of rear LH ABS IN valve	Actuator (ABS IN valve) is active ("ACTIVE TEST" in "ABS" with CONSULT)	On
		When the actuator (ABS IN valve) is not active and actuator relay is active (ignition switch ON)	Off
RR LH OUT SOL (Note 2)	Operation status of rear LH ABS OUT valve	Actuator (ABS OUT valve) is active ("ACTIVE TEST" in "ABS" with CONSULT)	On
		When the actuator (ABS OUT valve) is not active and actuator relay is active (ignition switch ON)	Off
MOTOR RELAY	Motor and motor relay operation	Ignition switch ON or engine running (ABS operated)	On
		Ignition switch ON or engine running (ABS not operated)	Off
ACTUATOR RLY (Note 2)	Actuator relay operation	Vehicle stopped (Engine running)	On
		Vehicle stopped (Ignition switch ON)	Off
ABS WARN LAMP	ABS warning lamp (Note 3)	When ABS warning lamp is ON	On
		When ABS warning lamp is OFF	Off
OFF LAMP	VDC OFF indicator lamp (Note 3)	When VDC OFF indicator lamp is ON	On
		When VDC OFF indicator lamp is OFF	Off
SLIP/VDC LAMP	VDC warning lamp (Note 3)	When VDC warning lamp is ON	On
		When VDC warning lamp is blinking	
		When VDC warning lamp is OFF	Off
CV1	Operation status of cut valve 1 (CV1)	Actuator (cut valve 1) is active ("ACTIVE TEST" in "ABS" with CONSULT)	On
		When the actuator (cut valve 1) is not active and actuator relay is active (ignition switch ON)	Off
CV2	Operation status of cut valve 2 (CV2)	Actuator (cut valve 2) is active ("ACTIVE TEST" in "ABS" with CONSULT)	On
		When the actuator (cut valve 2) is not active and actuator relay is active (ignition switch ON)	Off
SV1	Operation status of suction valve 1 (SV1)	Actuator (suction valve 1) is active ("ACTIVE TEST" in "ABS" with CONSULT)	On
		When the actuator (suction valve 1) is not active and actuator relay is active (ignition switch ON)	Off

ABS ACTUATOR AND ELECTRIC UNIT (CONTROL UNIT)

< ECU DIAGNOSIS INFORMATION >

[VDC/TCS/ABS]

Monitor item	Display content	Data monitor	
		Condition	Reference value in normal operation
SV2	Operation status of suction valve 2 (SV2)	Actuator (suction valve 2) is active ("ACTIVE TEST" in "ABS" with CONSULT)	On
		When the actuator (suction valve 2) is not active and actuator relay is active (ignition switch ON)	Off
EBD SIGNAL	EBD operation	EBD is active	On
		EBD is inactive	Off
ABS SIGNAL	ABS operation	ABS is active	On
		ABS is inactive	Off
TCS SIGNAL	TCS operation	TCS is active	On
		TCS is inactive	Off
VDC SIGNAL	VDC operation	VDC is active	On
		VDC is inactive	Off
EBD FAIL SIG	EBD fail-safe signal	In EBD fail-safe	On
		EBD is normal	Off
ABS FAIL SIG	ABS fail-safe signal	In ABS fail-safe	On
		ABS is normal	Off
TCS FAIL SIG	TCS fail-safe signal	In TCS fail-safe	On
		TCS is normal	Off
VDC FAIL SIG	VDC fail-safe signal	In VDC fail-safe	On
		VDC is normal	Off
EBD WARN LAMP	Brake warning lamp (Note 3)	When brake warning lamp is ON	On
		When brake warning lamp is OFF	Off
CRANKING SIG	Crank operation	Crank is active	On
		Crank is inactive	Off
4WD FAIL REQ	ETS fail status	ETS fail	On
		ETS normal	Off
2WD/4WD	Drive axle	2WD model	2WD
		AWD model	4WD

NOTE:

- 1: Confirm tire pressure is normal.
- 2: A brief moment of On/Off condition occurs every 20 seconds after ignition switch turned ON. This is not malfunction because it is a operation for checking.
- 3: On and off timing for warning lamp and indicator lamp.
 - ABS warning lamp: Refer to [BRC-96, "Description"](#).
 - Brake warning lamp: Refer to [BRC-97, "Description"](#).
 - VDC warning lamp: Refer to [BRC-99, "Description"](#).
 - VDC OFF indicator lamp: Refer to [BRC-100, "Description"](#).

Wiring Diagram -BRAKE CONTROL SYSTEM-

INFOID:000000008457378

For connector terminal arrangements, harness layouts, and alphabets in a (option abbreviation; if not described in wiring diagram), refer to [GI-12, "Connector Information"](#).

ABS ACTUATOR AND ELECTRIC UNIT (CONTROL UNIT)

< ECU DIAGNOSIS INFORMATION >

[VDC/TCS/ABS]

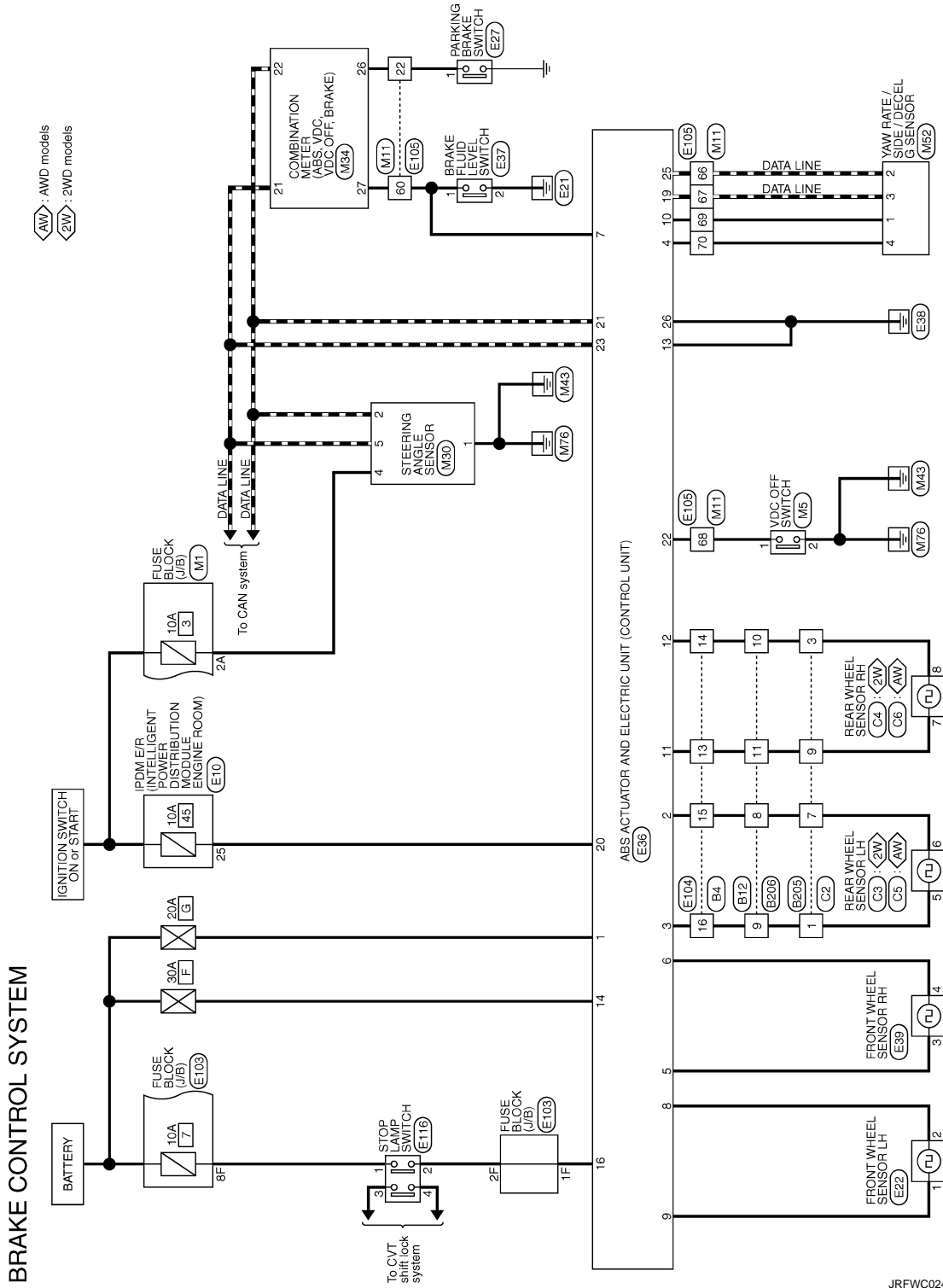

Fail-Safe

INFOID:000000008457379

ABS, EBD SYSTEM

If ABS malfunction electrically, ABS warning lamp and VDC warning lamp will turn ON. If EBD malfunction electrically, brake warning lamp, ABS warning lamp and VDC warning lamp will turn ON. Simultaneously, the VDC/TCS/ABS become one of the following conditions of the fail-safe function.

ABS ACTUATOR AND ELECTRIC UNIT (CONTROL UNIT)

< ECU DIAGNOSIS INFORMATION >

[VDC/TCS/ABS]

- For malfunction of ABS, only the EBD is activated and the condition of vehicle is the same condition of vehicles without TCS/ABS system.

NOTE:

ABS self-diagnosis sound may be heard. That is a normal condition because a self-diagnosis for "Ignition switch ON" and "The first starting" are being performed.

- For malfunction of EBD, EBD and ABS become inoperative, and the condition of vehicle is the same as the condition of vehicles without TCS/ABS, EBD system.

VDC/TCS

If VDC/TCS/ABS system malfunction electrically, VDC warning lamp are turned on, and the condition of vehicle is the same as the condition of vehicles without VDC/TCS control.

CAUTION:

If the Fail-Safe function is activated, then perform self-diagnosis for "ABS" with CONSULT.

DTC No. Index

INFOID:000000008457380

DTC	Items (CONSULT screen terms)	Reference
C1101	RR RH SENSOR-1	BRC-33, "DTC Logic"
C1102	RR LH SENSOR-1	
C1103	FR RH SENSOR-1	
C1104	FR LH SENSOR-1	
C1105	RR RH SENSOR-2	BRC-37, "DTC Logic"
C1106	RR LH SENSOR-2	
C1107	FR RH SENSOR-2	
C1108	FR LH SENSOR-2	BRC-42, "DTC Logic"
C1109	BATTERY VOLTAGE [ABNORMAL]	
C1110	CONTROLLER FAILURE	BRC-44, "DTC Logic"
C1111	PUMP MOTOR	BRC-45, "DTC Logic"
C1113	G SENSOR	BRC-47, "DTC Logic"
C1115	ABS SENSOR [ABNORMAL SIGNAL]	BRC-50, "DTC Logic"
C1116	STOP LAMP SW	BRC-56, "DTC Logic"
C1120	FR LH IN ABS SOL	BRC-58, "DTC Logic"
C1121	FR LH OUT ABS SOL	BRC-60, "DTC Logic"
C1122	FR RH IN ABS SOL	BRC-58, "DTC Logic"
C1123	FR RH OUT ABS SOL	BRC-60, "DTC Logic"
C1124	RR LH IN ABS SOL	BRC-58, "DTC Logic"
C1125	RR LH OUT ABS SOL	BRC-60, "DTC Logic"
C1126	RR RH IN ABS SOL	BRC-58, "DTC Logic"
C1127	RR RH OUT ABS SOL	BRC-60, "DTC Logic"
C1130	ENGINE SIGNAL 1	BRC-62, "DTC Logic"
C1140	ACTUATOR RLY	BRC-64, "DTC Logic"
C1142	PRESS SEN CIRCUIT	BRC-66, "DTC Logic"
C1143	ST ANG SEN CIRCUIT	BRC-68, "DTC Logic"
C1144	ST ANG SEN SIGNAL	BRC-71, "DTC Logic"
C1145	YAW RATE SENSOR	BRC-47, "DTC Logic"
C1146	SIDE G-SEN CIRCUIT	
C1155	BR FLUID LEVEL LOW	BRC-73, "DTC Logic"
C1160	DECEL G SEN SET	BRC-77, "DTC Logic"
C1161	SIDE G SEN SET	BRC-79, "DTC Logic"

A
B
C
D
E
G
H
I
J
K
L
M
N
O
P

BRC

ABS ACTUATOR AND ELECTRIC UNIT (CONTROL UNIT)

< ECU DIAGNOSIS INFORMATION >

[VDC/TCS/ABS]

DTC	Items (CONSULT screen terms)	Reference
C1162	PRESS SEN SET	BRC-80, "DTC Logic"
C1164	CV1	BRC-81, "DTC Logic"
C1165	CV2	
C1166	SV1	BRC-83, "DTC Logic"
C1167	SV2	
U1000	CAN COMM CIRCUIT	BRC-85, "DTC Logic"
U1002	SYSTEM COMM (CAN)	BRC-87, "DTC Logic"

EXCESSIVE ABS FUNCTION OPERATION FREQUENCY

< SYMPTOM DIAGNOSIS >

[VDC/TCS/ABS]

SYMPTOM DIAGNOSIS

EXCESSIVE ABS FUNCTION OPERATION FREQUENCY

Diagnosis Procedure

INFOID:000000008457381

1.CHECK START

Check the front and rear brake force distribution using a brake tester. Refer to [BR-52, "General Specifications"](#).

Is the inspection result normal?

YES >> GO TO 2.

NO >> Check the brake system.

2.CHECK FRONT AND REAR AXLE

Make sure that there is no excessive play in the front and rear axles.

• Front

- 2WD: Refer to [FAX-8, "Inspection"](#).

- AWD: Refer to [FAX-34, "Inspection"](#).

• Rear

- 2WD: Refer to [RAX-4, "Inspection"](#).

- AWD: Refer to [RAX-11, "Inspection"](#).

Is the inspection result normal?

YES >> GO TO 3.

NO >> Repair or replace error-detected parts.

3.CHECK WHEEL SENSOR AND SENSOR ROTOR

Check the following.

• Wheel sensor installation for damage.

- Front wheel sensor: Refer to [BRC-121, "FRONT WHEEL SENSOR : Exploded View"](#).

- Rear wheel sensor: Refer to [BRC-122, "REAR WHEEL SENSOR : Exploded View"](#).

• Wheel sensor connector connection.

• Wheel sensor harness inspection.

• Sensor rotor installation for damage.

- Front sensor rotor: Refer to [BRC-124, "FRONT SENSOR ROTOR : Exploded View"](#).

- Rear sensor rotor: Refer to [BRC-124, "REAR SENSOR ROTOR : Exploded View"](#).

Is the inspection result normal?

YES >> GO TO 4.

NO >> Replace wheel sensor or sensor rotor.

• Front wheel sensor: Refer to [BRC-121, "FRONT WHEEL SENSOR : Exploded View"](#).

• Rear wheel sensor: Refer to [BRC-122, "REAR WHEEL SENSOR : Exploded View"](#).

• Front sensor rotor: Refer to [BRC-124, "FRONT SENSOR ROTOR : Exploded View"](#).

• Rear sensor rotor: Refer to [BRC-124, "REAR SENSOR ROTOR : Exploded View"](#).

4.CHECK ABS WARNING LAMP DISPLAY

Make sure that the ABS warning lamp is turned off after the ignition switch is turned ON or when driving.

Is the inspection result normal?

YES >> Normal

NO >> Perform self-diagnosis for "ABS" with CONSULT.

A
B
C
D
E
BRC
G
H
I
J
K
L
M
N
O
P

UNEXPECTED PEDAL REACTION

< SYMPTOM DIAGNOSIS >

[VDC/TCS/ABS]

UNEXPECTED PEDAL REACTION

Diagnosis Procedure

INFOID:000000008457382

1.CHECK BRAKE PEDAL, BRAKE BOOSTER, BRAKE MASTER CYLINDER

Check the brake pedal, brake booster, brake master cylinder mounting condition.

- Brake pedal: Refer to [BR-19, "Exploded View"](#).
- Brake booster: Refer to [BR-29, "Exploded View"](#).
- Brake master cylinder: Refer to [BR-26, "Exploded View"](#).

Is the inspection result normal?

- YES >> GO TO 2.
- NO >> Repair or replace error-detected parts.

2.CHECK BRAKE PEDAL STROKE

Check the brake pedal stroke. Refer to [BR-8, "Inspection and Adjustment"](#).

Is the stroke too large?

- YES >> Bleed air from brake tube and hose. Refer to [BR-12, "Bleeding Brake System"](#).
- NO >> GO TO 3.

3.CHECK FUNCTION

Disconnect ABS actuator and electric unit (control unit) harness connector to deactivate ABS. Check if braking force is normal in this condition. Connect harness connector after inspection.

Is the inspection result normal?

- YES >> Normal
- NO >> Check brake system.

THE BRAKING DISTANCE IS LONG

< SYMPTOM DIAGNOSIS >

[VDC/TCS/ABS]

THE BRAKING DISTANCE IS LONG

Diagnosis Procedure

INFOID:000000008457383

CAUTION:

The stopping distance on slippery road surfaces might be longer with the ABS operating than when the ABS is not operating.

1.CHECK FUNCTION

Turn the ignition switch OFF and disconnect ABS actuator and electric unit (control unit) harness connector to deactivate ABS. In this condition, check the stopping distance. After inspection, connect connector.

Is the inspection result normal?

YES >> Normal

NO >> Check brake system.

A
B
C
D
E
G
H
I
J
K
L
M
N
O
P

BRC

ABS FUNCTION DOES NOT OPERATE

< SYMPTOM DIAGNOSIS >

[VDC/TCS/ABS]

ABS FUNCTION DOES NOT OPERATE

Diagnosis Procedure

INFOID:000000008457384

CAUTION:

ABS does not operate when speed is 10 km/h (6 MPH) or lower.

1.CHECK ABS WARNING LAMP DISPLAY

Make sure that the ABS warning lamp turns OFF after ignition switch is turned ON or when driving.

Is the inspection result normal?

YES >> Normal

NO >> Perform self-diagnosis for "ABS" with CONSULT.

PEDAL VIBRATION OR ABS OPERATION SOUND OCCURS

< SYMPTOM DIAGNOSIS >

[VDC/TCS/ABS]

PEDAL VIBRATION OR ABS OPERATION SOUND OCCURS

Diagnosis Procedure

INFOID:000000008457385

CAUTION:

Under the following conditions, ABS is activated and vibration is felt when brake pedal is lightly depressed (just place a foot on it). However, this is normal.

- When shifting gears
- When driving on slippery road
- During cornering at high speed
- When passing over bumps or grooves [at approximately 50 mm (1.97 in) or more]
- When pulling away just after starting engine [at approximately 10 km/h (6 MPH) or higher]

1. SYMPTOM CHECK 1

Check that there are pedal vibrations when the engine is started.

Do vibrations occur?

YES >> GO TO 2.

NO >> Inspect the brake pedal. Refer to [BR-20, "Inspection and Adjustment"](#).

2. SYMPTOM CHECK 2

Check that there are ABS operation noises when the engine is started.

Do the operation noises occur?

YES >> GO TO 3.

NO >> Perform self-diagnosis for "ABS" with CONSULT.

3. SYMPTOM CHECK 3

Check symptoms when electrical component (headlamps, etc.) switches are operated.

Do symptoms occur?

YES >> Check if there is a radio, antenna, antenna lead wire, or wiring close to the control unit. If there is, move it farther away.

NO >> Normal

A
B
C
D
E
BRC
G
H
I
J
K
L
M
N
O
P

VEHICLE JERKS DURING VDC/TCS/ABS CONTROL

< SYMPTOM DIAGNOSIS >

[VDC/TCS/ABS]

VEHICLE JERKS DURING VDC/TCS/ABS CONTROL

Diagnosis Procedure

INFOID:000000008457386

1.SYMPTOM CHECK

Check if the vehicle jerks during VDC/TCS/ABS control.

Is the inspection result normal?

- YES >> Normal.
- NO >> GO TO 2.

2.PERFORM SELF-DIAGNOSIS (1)

Perform self-diagnosis for "ABS" with CONSULT.

Are self-diagnosis results indicated?

- YES >> Check the corresponding items, make repairs, and perform self-diagnosis for "ABS" with CONSULT.
- NO >> GO TO 3.

3.CHECK CONNECTOR

1. Turn the ignition switch OFF.
2. Disconnect ABS actuator and electric unit (control unit) harness connector.
3. Check the terminal for deformation, disconnection, looseness, etc.
4. Securely connect harness connectors and perform self-diagnosis for "ABS" with CONSULT.

Are self-diagnosis results indicated?

- YES >> If poor contact, damage, open or short circuit of connector terminal is found, repair or replace.
- NO >> GO TO 4.

4.PERFORM SELF-DIAGNOSIS (2)

Perform self-diagnosis for "ENGINE" and "TRANSMISSION" with CONSULT.

Are self-diagnosis results indicated?

- YES >> Check the corresponding items.
- NO >> Replace ABS actuator and electric unit (control unit). Refer to [BRC-125. "Exploded View"](#).

NORMAL OPERATING CONDITION

< SYMPTOM DIAGNOSIS >

[VDC/TCS/ABS]

NORMAL OPERATING CONDITION

Description

INFOID:000000008457387

Symptom	Result
Slight vibrations are felt on the brake pedal and the operation noises occur, when VDC, TCS or ABS is activated.	This is a normal condition due to the VDC, TCS or ABS activation.
Stopping distance is longer than that of vehicles without ABS when the vehicle drives on rough, gravel, or snow-covered (fresh, deep snow) roads.	
The brake pedal moves and generates noises, when TCS or VDC is activated due to rapid acceleration or sharp turn.	
The brake pedal vibrates and motor operation noises occur from the engine room, after the engine starts and just after the vehicle starts.	This is a normal, and it is caused by the ABS operation check.
Depending on the road conditions, the driver may experience a sluggish feel.	This is normal, because TCS places the highest priority on the optimum traction (stability).
TCS may activate momentarily if wheel speed changes when driving over location where friction coefficient varies, when downshifting, or when fully depressing accelerator pedal.	
The ABS warning lamp and VDC warning lamp may turn ON when the vehicle is subject to strong shaking or large vibration, such as when the vehicle is rotating on a turntable or located on a ship while the engine is running.	In this case, restart the engine on a normal road. If the normal condition is restored, there is no malfunction. At that time, erase the self-diagnosis memory.
VDC may not operate normally or the ABS warning lamp and VDC warning lamp may illuminate, when running on a special road that is extremely slanted (e.g. bank in a circuit course).	
A malfunction may occur in the yaw rate/side G sensor system, when the vehicle turns sharply, such as during a spin turn, axle turn, or drift driving, while the VDC function is off (VDC warning lamp illuminated).	
The vehicle speed will not increase even though the accelerator pedal is depressed, when inspecting the speedometer on a 2-wheel chassis dynamometer.	Normal (Deactivate the VDC/TCS function before performing an inspection on a chassis dynamometer.)

A
B
C
D
E
BRC
G
H
I
J
K
L
M
N
O
P

PRECAUTION

PRECAUTIONS
FOR USA AND CANADA

FOR USA AND CANADA : Precaution for Supplemental Restraint System (SRS) "AIR BAG" and "SEAT BELT PRE-TENSIONER"

INFOID:000000008457388

The Supplemental Restraint System such as "AIR BAG" and "SEAT BELT PRE-TENSIONER", used along with a front seat belt, helps to reduce the risk or severity of injury to the driver and front passenger for certain types of collision. This system includes seat belt switch inputs and dual stage front air bag modules. The SRS system uses the seat belt switches to determine the front air bag deployment, and may only deploy one front air bag, depending on the severity of a collision and whether the front occupants are belted or unbelted. Information necessary to service the system safely is included in the "SRS AIR BAG" and "SEAT BELT" of this Service Manual.

WARNING:

Always observe the following items for preventing accidental activation.

- To avoid rendering the SRS inoperative, which could increase the risk of personal injury or death in the event of a collision that would result in air bag inflation, all maintenance must be performed by an authorized NISSAN/INFINITI dealer.
- Improper maintenance, including incorrect removal and installation of the SRS, can lead to personal injury caused by unintentional activation of the system. For removal of Spiral Cable and Air Bag Module, see "SRS AIR BAG".
- Never use electrical test equipment on any circuit related to the SRS unless instructed to in this Service Manual. SRS wiring harnesses can be identified by yellow and/or orange harnesses or harness connectors.

PRECAUTIONS WHEN USING POWER TOOLS (AIR OR ELECTRIC) AND HAMMERS

WARNING:

Always observe the following items for preventing accidental activation.

- When working near the Air Bag Diagnosis Sensor Unit or other Air Bag System sensors with the ignition ON or engine running, never use air or electric power tools or strike near the sensor(s) with a hammer. Heavy vibration could activate the sensor(s) and deploy the air bag(s), possibly causing serious injury.
- When using air or electric power tools or hammers, always switch the ignition OFF, disconnect the battery, and wait at least 3 minutes before performing any service.

FOR USA AND CANADA : Precaution for Procedure without Cowl Top Cover

INFOID:000000008457389

When performing the procedure after removing cowl top cover, cover the lower end of windshield with urethane, etc to prevent damage to windshield.

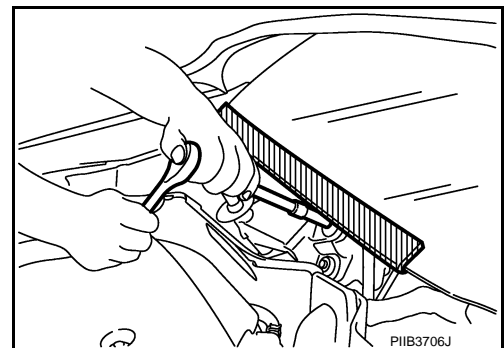

FOR USA AND CANADA : Precaution for Brake System

INFOID:000000008457390

WARNING:

Since dust covering the front and rear brakes has an affect on human body, the dust must be removed with a dust collector. Never splatter the dust with an air blow gun.

CAUTION:

- Brake fluid use refer to [MA-16, "FOR NORTH AMERICA : Fluids and Lubricants"](#).
- Never reuse drained brake fluid.

PRECAUTIONS

< PRECAUTION >

[VDC/TCS/ABS]

- Never spill or splash brake fluid on painted surfaces. Brake fluid may seriously damage paint. Wipe it off immediately and wash with water if it gets on a painted surface.
- Never use mineral oils such as gasoline or light oil to clean. They may damage rubber parts and cause improper operation.
- Always loosen the brake tube flare nut with a flare nut wrench.
- Tighten the brake tube flare nut to the specified torque with crowfoot (A) and torque wrench (B).
- Always confirm the specified tightening torque when installing the brake pipes.
- Turn the ignition switch OFF and disconnect the ABS actuator and electric unit (control unit) harness connector or the battery negative terminal before performing the work.
- Check that no brake fluid leakage is present after replacing the parts.

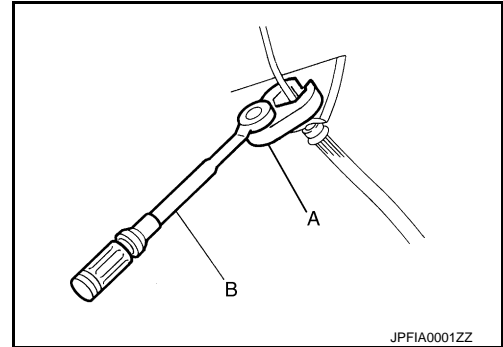

FOR USA AND CANADA : Precaution for Brake Control

INFOID:000000008457391

- Always perform a pre-driving check to drive the vehicle.
- Always check speed and safety while driving the vehicle.
- To operate CONSULT while driving, more than one person is required to be in the vehicle to avoid interference to driving and ensure safety.
- When starting engine or when starting vehicle just after starting engine, brake pedal may vibrate or motor operating noise may be heard from engine compartment. This is normal condition.
- When an error is indicated by ABS or another warning lamp, collect all necessary information from customer (what symptoms are present under what conditions) and check for estimate causes before starting diagnostic servicing. Besides electrical system inspection, check the brake booster operation, brake fluid level, and oil leaks.
- If tire size and type are used in an improper combination, or brake pads are not Genuine NISSAN parts, stopping distance or steering stability may deteriorate.
- ABS might be out of order or malfunctions by putting a radio (wiring inclusive), an antenna and a lead-in wire near the control unit.
- VDC system may not operate normally or a VDC warning lamp may light.
- When replacing the following parts with parts other than genuine parts or making modifications: Suspension-related parts (shock absorber, spring, bushing, etc.), tires, wheels (other than specified sizes), brake-related parts (pad, rotor, caliper, etc.), engine-related parts (muffler, ECM, etc.) and body reinforcement-related parts (roll bar, tower bar, etc.).
- When driving with worn or deteriorated suspension, tires and brake-related parts.

FOR USA AND CANADA : Precaution for Harness Repair

INFOID:000000008457392

- Solder the repair part, and wrap it with tape. [Twisted wire fray must be 110 mm (4.33 in) or less.]

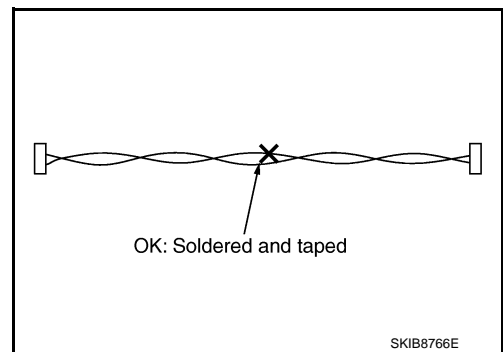

PRECAUTIONS

[VDC/TCS/ABS]

< PRECAUTION >

- Never bypass the repair point with wire. (If it is bypassed, the turn-out point cannot be separated and the twisted wire characteristics are lost.)

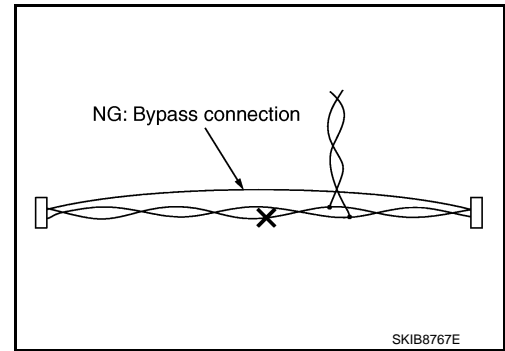

FOR MEXICO

FOR MEXICO : Precaution for Supplemental Restraint System (SRS) "AIR BAG" and "SEAT BELT PRE-TENSIONER"

INFOID:000000008457393

The Supplemental Restraint System such as "AIR BAG" and "SEAT BELT PRE-TENSIONER", used along with a front seat belt, helps to reduce the risk or severity of injury to the driver and front passenger for certain types of collision. Information necessary to service the system safely is included in the "SRS AIR BAG" and "SEAT BELT" of this Service Manual.

WARNING:

Always observe the following items for preventing accidental activation.

- To avoid rendering the SRS inoperative, which could increase the risk of personal injury or death in the event of a collision that would result in air bag inflation, all maintenance must be performed by an authorized NISSAN/INFINITI dealer.
- Improper maintenance, including incorrect removal and installation of the SRS, can lead to personal injury caused by unintentional activation of the system. For removal of Spiral Cable and Air Bag Module, see "SRS AIR BAG".
- Never use electrical test equipment on any circuit related to the SRS unless instructed to in this Service Manual. SRS wiring harnesses can be identified by yellow and/or orange harnesses or harness connectors.

PRECAUTIONS WHEN USING POWER TOOLS (AIR OR ELECTRIC) AND HAMMERS

WARNING:

Always observe the following items for preventing accidental activation.

- When working near the Air Bag Diagnosis Sensor Unit or other Air Bag System sensors with the ignition ON or engine running, never use air or electric power tools or strike near the sensor(s) with a hammer. Heavy vibration could activate the sensor(s) and deploy the air bag(s), possibly causing serious injury.
- When using air or electric power tools or hammers, always switch the ignition OFF, disconnect the battery, and wait at least 3 minutes before performing any service.

FOR MEXICO : Precaution for Procedure without Cowl Top Cover

INFOID:000000008457394

When performing the procedure after removing cowl top cover, cover the lower end of windshield with urethane, etc to prevent damage to windshield.

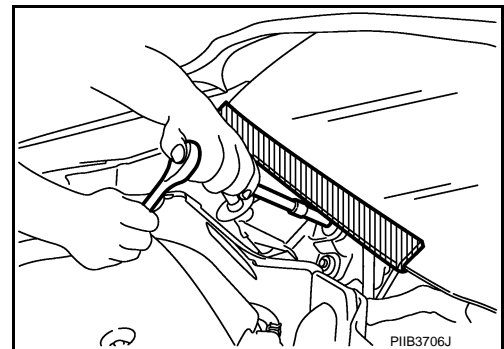

FOR MEXICO : Precaution for Brake System

INFOID:000000008457395

WARNING:

PRECAUTIONS

< PRECAUTION >

[VDC/TCS/ABS]

Since dust covering the front and rear brakes has an affect on human body, the dust must be removed with a dust collector. Never splatter the dust with an air blow gun.

CAUTION:

- Brake fluid use refer to [MA-17, "FOR MEXICO : Fluids and Lubricants"](#).
- Never reuse drained brake fluid.
- Never spill or splash brake fluid on painted surfaces. Brake fluid may seriously damage paint. Wipe it off immediately and wash with water if it gets on a painted surface.
- Never use mineral oils such as gasoline or light oil to clean. They may damage rubber parts and cause improper operation.
- Always loosen the brake tube flare nut with a flare nut wrench.
- Tighten the brake tube flare nut to the specified torque with crowfoot (A) and torque wrench (B).
- Always confirm the specified tightening torque when installing the brake pipes.
- Turn the ignition switch OFF and disconnect the ABS actuator and electric unit (control unit) harness connector or the battery negative terminal before performing the work.
- Check that no brake fluid leakage is present after replacing the parts.

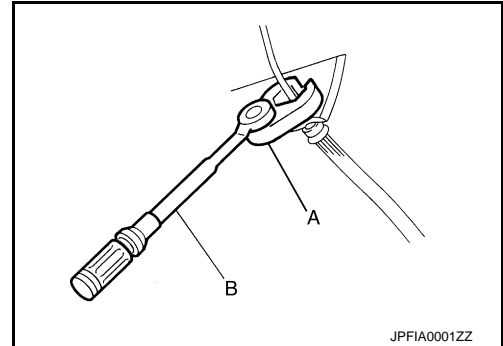

FOR MEXICO : Precaution for Brake Control

INFOID:000000008457396

- Always perform a pre-driving check to drive the vehicle.
- Always check speed and safety while driving the vehicle.
- To operate CONSULT while driving, more than one person is required to be in the vehicle to avoid interference to driving and ensure safety.
- When starting engine or when starting vehicle just after starting engine, brake pedal may vibrate or motor operating noise may be heard from engine compartment. This is normal condition.
- When an error is indicated by ABS or another warning lamp, collect all necessary information from customer (what symptoms are present under what conditions) and check for estimate causes before starting diagnostic servicing. Besides electrical system inspection, Check the brake booster operation, brake fluid level, and oil leaks.
- If tire size and type are used in an improper combination, or brake pads are not Genuine NISSAN parts, stopping distance or steering stability may deteriorate.
- ABS might be out of order or malfunctions by putting a radio (wiring inclusive), an antenna and a lead-in wire near the control unit.
- VDC system may not operate normally or a VDC warning lamp may light.
- When replacing the following parts with parts other than genuine parts or making modifications: Suspension-related parts (shock absorber, spring, bushing, etc.), tires, wheels (other than specified sizes), brake-related parts (pad, rotor, caliper, etc.), engine-related parts (muffler, ECM, etc.) and body reinforcement-related parts (roll bar, tower bar, etc.).
- When driving with worn or deteriorated suspension, tires and brake-related parts.

FOR MEXICO : Precaution for Harness Repair

INFOID:000000008457397

- Solder the repair part, and wrap it with tape. [Twisted wire fray must be 110 mm (4.33 in) or less.]

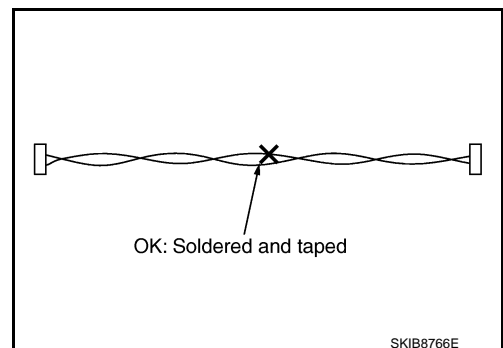

PRECAUTIONS

[VDC/TCS/ABS]

< PRECAUTION >

- Never bypass the repair point with wire. (If it is bypassed, the turn-out point cannot be separated and the twisted wire characteristics are lost.)

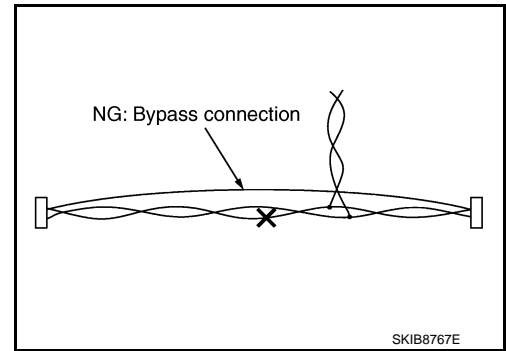

REMOVAL AND INSTALLATION

WHEEL SENSOR

FRONT WHEEL SENSOR

FRONT WHEEL SENSOR : Exploded View

INFOID:000000008457398

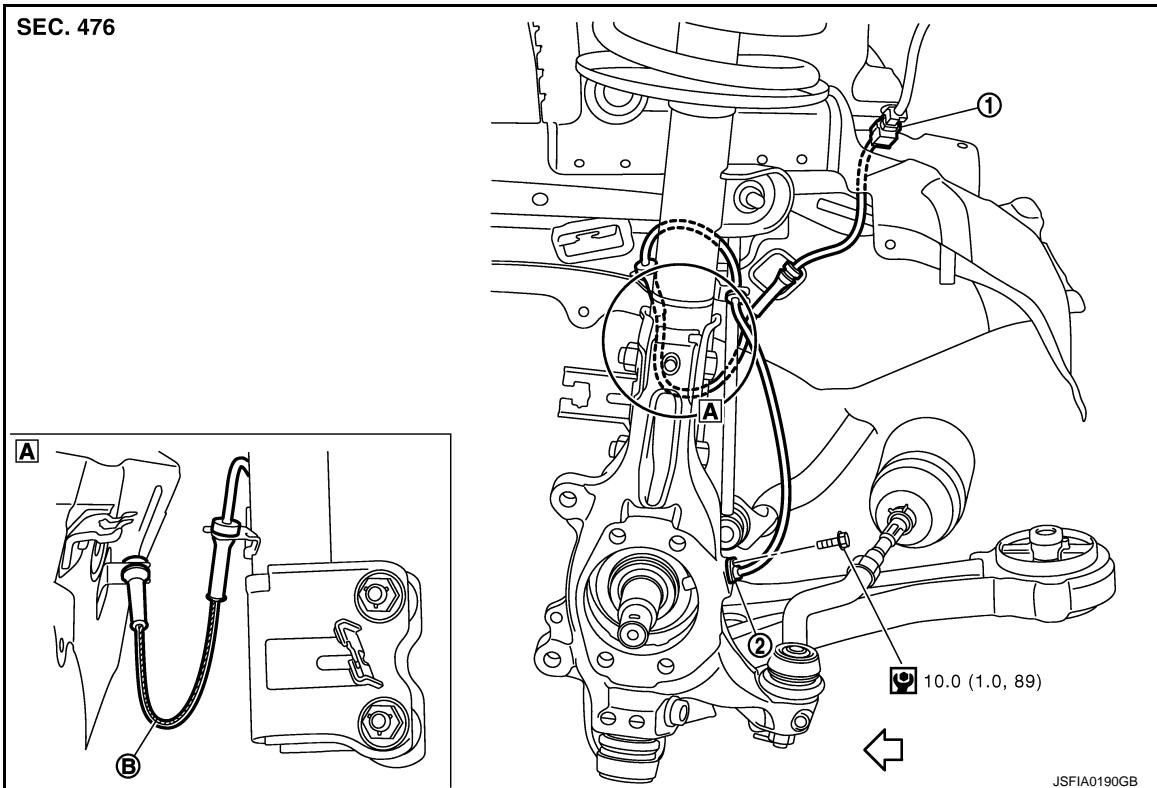

1. Front LH wheel sensor harness connector 2. Front LH wheel sensor

B. Color line (slant line)

← : Vehicle front

Refer to [GI-4, "Components"](#) for symbol in the figure.

NOTE:

The above figure (front side) shows left side. Right side is the mirror image.

FRONT WHEEL SENSOR : Removal and Installation

INFOID:000000008457399

REMOVAL

Be careful with the following when removing sensor.

CAUTION:

- **Never twist sensor harness as much as possible, when removing it. Pull sensors out without pulling sensor harness.**
- **Be careful to avoid damaging sensor edges or rotor teeth. Remove wheel sensor first before removing front or rear wheel hub. This is to avoid damage to sensor wiring and loss of sensor function.**
- **When you see the harness of the wheel sensor from the front side of the vehicle ensure that the color lines (B) are not twisted.**

INSTALLATION

Be careful with the following when installing wheel sensor. Tighten installation bolts to the specified torques.

A

B

C

D

E

BRC

G

H

I

J

K

L

M

N

O

P

WHEEL SENSOR

[VDC/TCS/ABS]

< REMOVAL AND INSTALLATION >

- When installing, make sure there is no foreign material such as iron chips on and in the mounting hole of the wheel sensor. Make sure no foreign material has been caught in the sensor rotor. Remove any foreign material and clean the mount.
- When installing wheel sensor, be sure to press rubber grommets in until they lock at locations shown above in the figure. When installed, harness must not be twisted.

REAR WHEEL SENSOR

REAR WHEEL SENSOR : Exploded View

INFOID:000000008457400

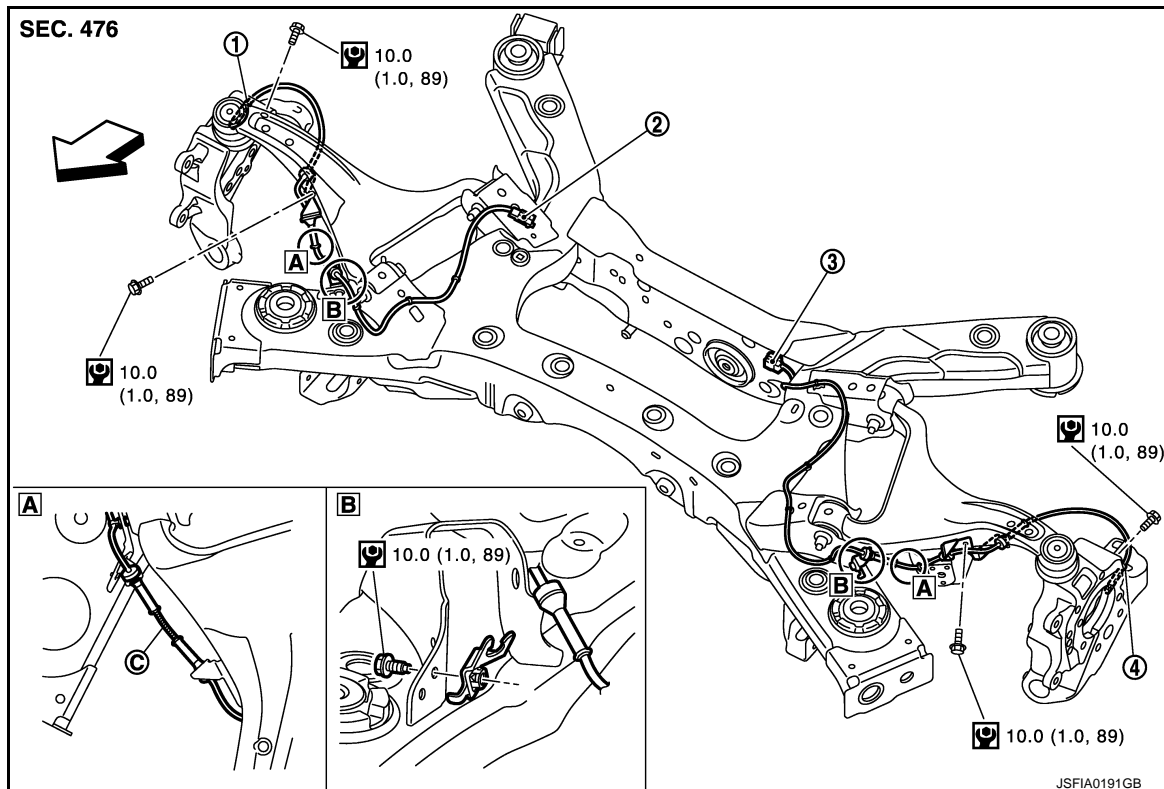

1. Rear RH wheel sensor
2. Rear RH wheel sensor harness connector
3. Rear LH wheel sensor connector
4. Rear LH wheel sensor

B. AWD models only

C. Color line (slant line)

↔ : Vehicle front

Refer to [GI-4, "Components"](#) for symbol in the figure.

REAR WHEEL SENSOR : Removal and Installation

INFOID:000000008457401

REMOVAL

Be careful with the following when removing sensor.

CAUTION:

- **Never twist sensor harness as much as possible, when removing it. Pull sensors out without pulling sensor harness.**
- **Be careful to avoid damaging sensor edges or rotor teeth. Remove wheel sensor first before removing front or rear wheel hub. This is to avoid damage to sensor wiring and loss of sensor function.**

INSTALLATION

Be careful with the following when installing wheel sensor. Tighten installation bolts to the specified torques.

- When installing, make sure there is no foreign material such as iron chips on and in the mounting hole of the wheel sensor. Make sure no foreign material has been caught in the sensor rotor. Remove any foreign material and clean the mount.

WHEEL SENSOR

< REMOVAL AND INSTALLATION >

[VDC/TCS/ABS]

- When installing wheel sensor, be sure to press rubber grommets in until they lock at locations shown above in the figure. When installed, harness must not be twisted.

A

B

C

D

E

BRC

G

H

I

J

K

L

M

N

O

P

SENSOR ROTOR

< REMOVAL AND INSTALLATION >

[VDC/TCS/ABS]

SENSOR ROTOR

FRONT SENSOR ROTOR

FRONT SENSOR ROTOR : Exploded View

INFOID:000000008457402

Refer to [FAX-10, "Exploded View"](#) (2WD), [FAX-36, "Exploded View"](#) (AWD).

FRONT SENSOR ROTOR : Removal and Installation

INFOID:000000008457403

REMOVAL

Sensor rotor cannot be disassembled. Remove the sensor rotor together with hub bearing assembly. Refer to [FAX-10, "Removal and Installation"](#) (2WD), [FAX-36, "Removal and Installation"](#) (AWD).

INSTALLATION

Sensor rotor cannot be disassembled. Install the sensor rotor together with hub bearing assembly. Refer to [FAX-10, "Removal and Installation"](#) (2WD), [FAX-36, "Removal and Installation"](#) (AWD).

REAR SENSOR ROTOR

REAR SENSOR ROTOR : Exploded View

INFOID:000000008457404

Refer to [RAX-5, "Exploded View"](#) (2WD), [RAX-13, "Exploded View"](#) (AWD).

REAR SENSOR ROTOR : Removal and Installation

INFOID:000000008457405

REMOVAL

Sensor rotor cannot be disassembled. Remove the sensor rotor together with hub bearing assembly. Refer to [RAX-5, "Removal and Installation"](#) (2WD), [RAX-13, "Removal and Installation"](#) (AWD).

INSTALLATION

Sensor rotor cannot be disassembled. Install the sensor rotor together with hub bearing assembly. Refer to [RAX-5, "Removal and Installation"](#) (2WD), [RAX-13, "Removal and Installation"](#) (AWD).

ABS ACTUATOR AND ELECTRIC UNIT (CONTROL UNIT)

< REMOVAL AND INSTALLATION >

[VDC/TCS/ABS]

ABS ACTUATOR AND ELECTRIC UNIT (CONTROL UNIT)

Exploded View

INFOID:000000008457406

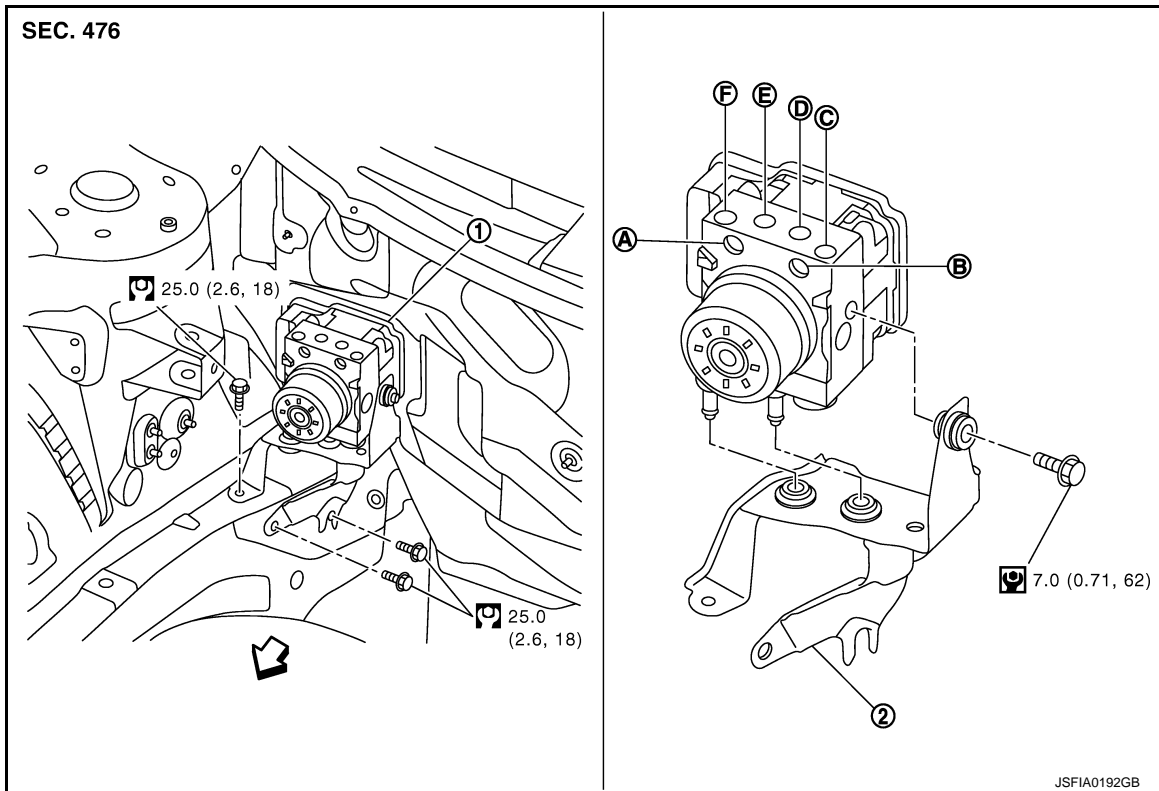

1. ABS actuator and electric unit (control unit) 2. Bracket

- A. To rear RH brake caliper B. To rear LH brake caliper C. From master cylinder primary side
D. To front RH brake caliper E. To front LH brake caliper F. From master cylinder secondary side

⇐ Vehicle front

Refer to [GI-4, "Components"](#) for symbol in the figure.

Removal and Installation

INFOID:000000008457407

REMOVAL

CAUTION:

- Never spill or splash brake fluid on painted surfaces. Brake fluid may seriously damage paint. Wipe it off immediately and wash with water if it gets on a painted surface.
- Before servicing, disconnect the battery cable from negative terminal.
- To remove brake tube, use a flare nut wrench to prevent flare nuts and brake tube from being damaged. To install, use flare nut crowfoot and torque wrench.
- Never apply excessive impact to ABS actuator and electric unit (control unit), such as dropping it.
- Never remove and install actuator by holding harness.

1. Remove cowl top. Refer to [EXT-20, "Exploded View"](#).
2. Disconnect ABS actuator and electric unit (control unit) harness connector.
3. Loosen brake tube flare nuts, then remove brake tubes from ABS actuator and electric unit (control unit).
4. Remove ABS actuator and electric unit (control unit) bracket mounting bolts.
5. Remove ABS actuator and electric unit (control unit) from vehicle.

INSTALLATION

Note the following, and install in the reverse order of removal.

- Before servicing, disconnect the battery cable from negative terminal.

ABS ACTUATOR AND ELECTRIC UNIT (CONTROL UNIT)

[VDC/TCS/ABS]

< REMOVAL AND INSTALLATION >

- To remove brake tube, use a flare nut wrench to prevent flare nuts and brake tube from being damaged. To install, use flare nut crowfoot and torque wrench.
 - Never apply excessive impact to ABS actuator and electric unit (control unit), such as dropping it.
 - Never remove and install actuator by holding harness.
 - After work is completed, bleed air from brake tube. Refer to [BR-12. "Bleeding Brake System"](#).
 - After installing harness connector in the ABS actuator and electric unit (control unit), make sure harness connector is securely locked.
 - After removing an ABS actuator and electric unit (control unit), be sure to perform the following procedure.
 - Calibration of decel G sensor: Refer to [BRC-10. "CALIBRATION OF DECEL G SENSOR : Description"](#).
 - After replacing an ABS actuator and electric unit (control unit), be sure to perform the following procedure.
 - Adjustment of steering angle sensor neutral position: Refer to [BRC-9. "ADJUSTMENT OF STEERING ANGLE SENSOR NEUTRAL POSITION : Description"](#).
 - Calibration of decel G sensor: Refer to [BRC-10. "CALIBRATION OF DECEL G SENSOR : Description"](#).
- Install ABS actuator and electric unit (control unit) as per the following steps.

1. Temporarily tighten mounting bolt (1) because the bracket (2) is temporarily being hold.
2. Tighten mounting bolt (3) while holding the bracket.
3. Tighten mounting bolts to the specified torque in the order of (4), (1).

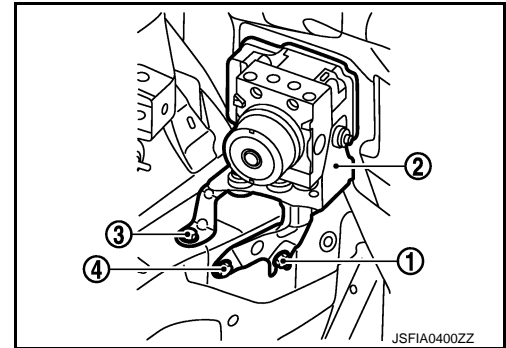

YAW RATE/SIDE/DECEL G SENSOR

< REMOVAL AND INSTALLATION >

[VDC/TCS/ABS]

YAW RATE/SIDE/DECEL G SENSOR

Exploded View

INFOID:000000008457408

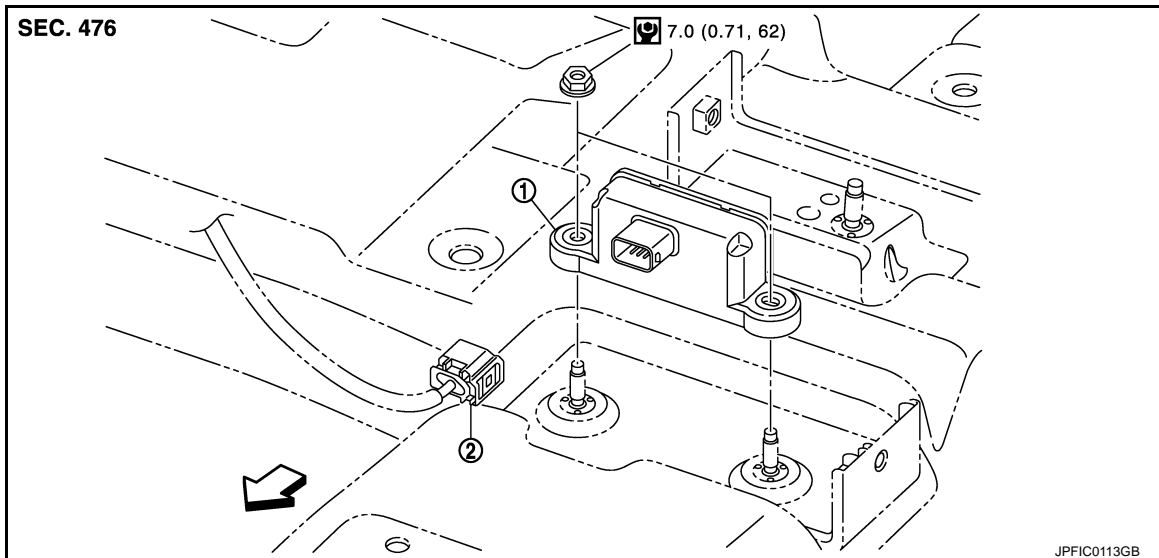

1. Yaw rate/side/decel G sensor
2. Connector

←: Vehicle front

Refer to [GI-4, "Components"](#) for symbol in the figure.

Removal and Installation

INFOID:000000008457409

REMOVAL

CAUTION:

Never drop or strike yaw rate/side/decel G sensor, or never use power tool etc., because yaw rate/side/decel G sensor is sensitive to the impact.

1. Remove center console assembly. Refer to [IP-20, "Exploded View"](#).
2. Remove rear ventilator duct. Refer to [VTL-58, "REAR VENTILATOR DUCT 2 : Exploded View"](#) (without 7 inch display), [VTL-121, "REAR VENTILATOR DUCT 2 : Exploded View"](#) (with 7 inch display).
3. Disconnect yaw rate/side/decel G sensor harness connector.
4. Remove mounting nuts.
5. Remove yaw rate/side/decel G sensor.

INSTALLATION

Note the following, and install in the reverse order of removal.

- Never drop or strike yaw rate/side/decel G sensor, or never use power tool etc., because yaw rate/side/decel G sensor is sensitive to the impact.
- After removing/replacing a yaw rate/side/decel G sensor, be sure to perform the calibration of decel G sensor. Refer to [BRC-10, "CALIBRATION OF DECEL G SENSOR : Description"](#).

STEERING ANGLE SENSOR

< REMOVAL AND INSTALLATION >

[VDC/TCS/ABS]

STEERING ANGLE SENSOR

Exploded View

INFOID:000000008457410

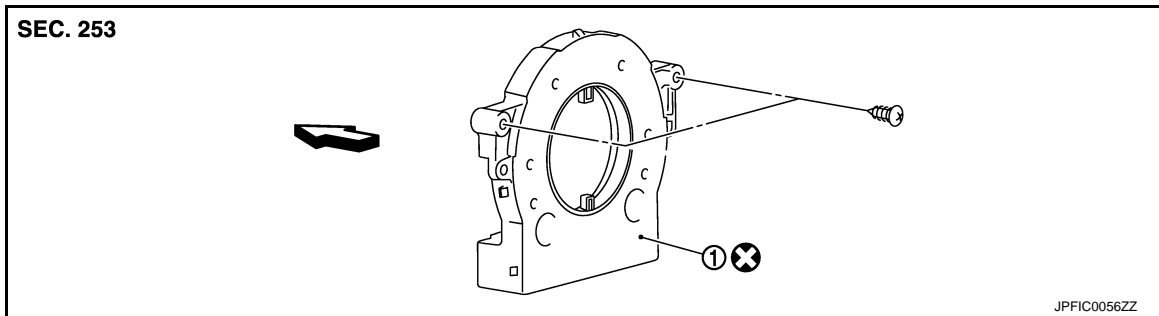

1. Steering angle sensor

↔: Vehicle front

Removal and Installation

INFOID:000000008457411

REMOVAL

1. Remove spiral cable assembly. Refer to [SR-14. "Exploded View"](#).
2. Remove steering angle sensor from spiral cable assembly.

INSTALLATION

Note the following, and install in the reverse order of removal.

- Never reuse steering angle sensor.
- After removing/replacing a steering angle sensor, be sure to perform the adjustment of steering angle sensor neutral position. Refer to [BRC-9. "ADJUSTMENT OF STEERING ANGLE SENSOR NEUTRAL POSITION : Description"](#).

VDC OFF SWITCH

< REMOVAL AND INSTALLATION >

[VDC/TCS/ABS]

VDC OFF SWITCH

Removal and Installation

INFOID:000000008457412

REMOVAL

1. Remove lower instrument panel LH. Refer to [IP-12, "Exploded View"](#).
2. Remove VDC OFF switch.

INSTALLATION

Installation is the reverse order of removal.

A

B

C

D

E

BRC

G

H

I

J

K

L

M

N

O

P