

SECTION **BCS**

BODY CONTROL SYSTEM

A
B
C

CONTENTS

BASIC INSPECTION	COMMON ITEM	F
INSPECTION AND ADJUSTMENT	COMMON ITEM : CONSULT Function (BCM - COMMON ITEM)	
ADDITIONAL SERVICE WHEN REPLACING CONTROL UNIT (BCM)	DOOR LOCK	G
ADDITIONAL SERVICE WHEN REPLACING CONTROL UNIT (BCM) : Description	DOOR LOCK : CONSULT Function (BCM - DOOR LOCK)	
ADDITIONAL SERVICE WHEN REPLACING CONTROL UNIT (BCM) : Work Procedure	REAR WINDOW DEFOGGER	H
CONFIGURATION (BCM)	REAR WINDOW DEFOGGER : CONSULT Function (BCM - REAR DEFOGGER)	
CONFIGURATION (BCM) : Description	BUZZER	I
CONFIGURATION (BCM) : Work Procedure	BUZZER : CONSULT Function (BCM - BUZZER).....	
CONFIGURATION (BCM) : Configuration list	INT LAMP	J
SHIPPING MODE CANCEL OPERATION	INT LAMP : CONSULT Function (BCM - INT LAMP)	
Description	HEADLAMP	K
Work Procedure	HEADLAMP : CONSULT Function (BCM - HEAD LAMP)	
SYSTEM DESCRIPTION	HEADLAMP : CONSULT Function (BCM - HEAD LAMP)	L
BODY CONTROL SYSTEM	WIPER	BCS
System Description	WIPER : CONSULT Function (BCM - WIPER)	
Component Parts Location	FLASHER	N
COMBINATION SWITCH READING SYSTEM	FLASHER : CONSULT Function (BCM - FLASHER)	
System Diagram	FLASHER : CONSULT Function (BCM - FLASHER)	O
System Description	INTELLIGENT KEY	
SIGNAL BUFFER SYSTEM	INTELLIGENT KEY : CONSULT Function (BCM - INTELLIGENT KEY)	P
System Diagram	COMB SW	
System Description	COMB SW : CONSULT Function (BCM - COMB SW)	
Component Parts Location	BCM	
POWER CONSUMPTION CONTROL SYSTEM	BCM : CONSULT Function (BCM - BCM)	
System Diagram		
System Description		
Component Parts Location		
DIAGNOSIS SYSTEM (BCM)		

IMMU	35	COMBINATION SWITCH OUTPUT CIRCUIT ...	49
IMMU : CONSULT Function (BCM - IMMU)	35	Diagnosis Procedure	49
BATTERY SAVER	36	ECU DIAGNOSIS INFORMATION	51
BATTERY SAVER : CONSULT Function (BCM - BATTERY SAVER)	36	BCM (BODY CONTROL MODULE)	51
TRUNK	37	Reference Value	51
TRUNK : CONSULT Function (BCM - TRUNK)	37	Wiring Diagram - BCM -	74
THEFT ALM	38	Fail-safe	89
THEFT ALM : CONSULT Function (BCM - THEFT)	38	DTC Inspection Priority Chart	90
RETAINED PWR	39	DTC Index	91
RETAINED PWR : CONSULT Function (BCM - RETAINED PWR)	39	SYMPTOM DIAGNOSIS	94
SIGNAL BUFFER	39	COMBINATION SWITCH SYSTEM SYMP- TOMS	94
SIGNAL BUFFER : CONSULT Function (BCM - SIGNAL BUFFER)	40	Symptom Table	94
AIR PRESSURE MONITOR	40	NORMAL OPERATING CONDITION	95
AIR PRESSURE MONITOR : CONSULT Function (BCM - AIR PRESSURE MONITOR)	40	Description	95
DTC/CIRCUIT DIAGNOSIS	42	PRECAUTION	96
U1000 CAN COMM	42	PRECAUTIONS	96
Description	42	FOR USA AND CANADA	96
DTC Logic	42	FOR USA AND CANADA : Precautions for Re- moving of Battery Terminal	96
Diagnosis Procedure	42	FOR USA AND CANADA : Precaution for Supple- mental Restraint System (SRS) "AIR BAG" and "SEAT BELT PRE-TENSIONER"	96
U1010 CONTROL UNIT (CAN)	43	FOR MEXICO	96
DTC Logic	43	FOR MEXICO : Precautions for Removing of Bat- tery Terminal	97
Diagnosis Procedure	43	FOR MEXICO : Precaution for Supplemental Re- straint System (SRS) "AIR BAG" and "SEAT BELT PRE-TENSIONER"	97
U0415 VEHICLE SPEED SIG	44	REMOVAL AND INSTALLATION	98
Description	44	BCM (BODY CONTROL MODULE)	98
DTC Logic	44	Exploded View	98
Diagnosis Procedure	44	Removal and Installation	98
B2562 LOW VOLTAGE	45	COMBINATION SWITCH	99
DTC Logic	45	Exploded View	99
Diagnosis Procedure	45	Removal and Installation	99
POWER SUPPLY AND GROUND CIRCUIT	46		
Diagnosis Procedure	46		
COMBINATION SWITCH INPUT CIRCUIT	47		
Diagnosis Procedure	47		

INSPECTION AND ADJUSTMENT

< BASIC INSPECTION >

BASIC INSPECTION

INSPECTION AND ADJUSTMENT

ADDITIONAL SERVICE WHEN REPLACING CONTROL UNIT (BCM)

ADDITIONAL SERVICE WHEN REPLACING CONTROL UNIT (BCM) : Description

INFOID:000000009722425

BEFORE REPLACEMENT

When replacing BCM, save or print current vehicle specification with CONSULT configuration before replacement.

NOTE:

If "READ CONFIGURATION" can not be used, use the "WRITE CONFIGURATION - Manual selection" after replacing BCM.

AFTER REPLACEMENT

CAUTION:

When replacing BCM, always perform "WRITE CONFIGURATION" with CONSULT. Or not doing so, BCM control function does not operate normally.

- Complete the procedure of "WRITE CONFIGURATION" in order.
- Configuration is different for each vehicle model. Confirm configuration of each vehicle model.
- If you set incorrect "WRITE CONFIGURATION", incidents might occur.

NOTE:

When replacing BCM, perform the system initialization (NATS) (if equipped).

ADDITIONAL SERVICE WHEN REPLACING CONTROL UNIT (BCM) : Work Procedure

INFOID:000000009722426

1. SAVING VEHICLE SPECIFICATION

CONSULT Configuration

Perform "READ CONFIGURATION" to save or print current vehicle specification. Refer to [BCS-4, "CONFIGURATION \(BCM\) : Description"](#).

NOTE:

If "READ CONFIGURATION" can not be used, use the "WRITE CONFIGURATION - Manual selection" after replacing BCM.

>> GO TO 2.

2. REPLACE BCM

Replace BCM. Refer to [BCS-98, "Removal and Installation"](#).

>> GO TO 3.

3. WRITING VEHICLE SPECIFICATION

CONSULT Configuration

Perform "WRITE CONFIGURATION - Config file" or "WRITE CONFIGURATION - Manual selection" to write vehicle specification. Refer to [BCS-4, "CONFIGURATION \(BCM\) : Work Procedure"](#).

>> GO TO 4.

4. INITIALIZE BCM (NATS) (IF EQUIPPED)

Perform BCM initialization. (NATS)

>> WORK END

CONFIGURATION (BCM)

A
B
C
D
E
F
G
H
I
J
K
L

BCS

N
O
P

INSPECTION AND ADJUSTMENT

< BASIC INSPECTION >

CONFIGURATION (BCM) : Description

INFOID:000000009722427

Vehicle specification needs to be written with CONSULT because it is not written after replacing BCM. Configuration has three functions as follows.

Function	Description
READ CONFIGURATION	<ul style="list-style-type: none">• Reads the vehicle configuration of current BCM.• Saves the read vehicle configuration.
WRITE CONFIGURATION - Manual selection	Writes the vehicle configuration with manual selection.
WRITE CONFIGURATION - Config file	Writes the vehicle configuration with saved data.

NOTE:

Manual setting item: Items which need selection by vehicle specifications

Automatic setting item: Items which are written in automatically (Setting can not be changed)

For some models and specifications, the automatic setting item may not be displayed.

CAUTION:

When replacing BCM, always perform "WRITE CONFIGURATION" with CONSULT. Or not doing so, BCM control function does not operate normally.

- Complete the procedure of "WRITE CONFIGURATION" in order.
- Configuration is different for each vehicle model. Confirm configuration of each vehicle model.
- Never perform "WRITE CONFIGURATION" except for new BCM.
- If you set incorrect "WRITE CONFIGURATION", incidents might occur.

CONFIGURATION (BCM) : Work Procedure

INFOID:000000009722428

1. WRITING MODE SELECTION

 CONSULT Configuration
Select "CONFIGURATION" of BCM.

When writing saved data >> GO TO 2.

When writing manually >> GO TO 3.

2. PERFORM "WRITE CONFIGURATION - CONFIG FILE"

 CONSULT Configuration
Perform "WRITE CONFIGURATION - Config file".

>> WORK END

3. PERFORM "WRITE CONFIGURATION - MANUAL SELECTION"

-  CONSULT Configuration
1. Select "WRITE CONFIGURATION - Manual selection".
 2. Identify the correct model and configuration list. Refer to [BCS-5, "CONFIGURATION \(BCM\) : Configuration list"](#).
 3. Confirm and/or change setting value for each item.
CAUTION:
Thoroughly read and understand the vehicle specification. ECU control may not operate normally if the setting is not correct.
NOTE:
If items are not displayed, touch "SETTING". Refer to [BCS-5, "CONFIGURATION \(BCM\) : Configuration list"](#) for written items and setting value.
 4. Select "SETTING".
CAUTION:
Make sure to select "SETTING" even if the indicated configuration of brand new BCM is same as the desirable configuration. If not, configuration which is set automatically by selecting vehicle model can not be memorized.
 5. When "COMMAND FINISHED", select "END".

>> GO TO 4.

INSPECTION AND ADJUSTMENT

< BASIC INSPECTION >

4. OPERATION CHECK

Confirm that each function controlled by BCM operates normally.

>> WORK END

CONFIGURATION (BCM) : Configuration list

INFOID:000000009722429

CAUTION:

Thoroughly read and understand the vehicle specification. ECU control may not operate normally if the setting is not correct.

EXCEPT FOR MEXICO

MANUAL SETTING ITEM		NOTE
Items	Setting value	
AV C/U	WITH ⇔ WITHOUT	<ul style="list-style-type: none"> • WITH: With navigation system • WITHOUT: Without navigation system
AUTO BACK DOOR	WITH ⇔ WITHOUT	<ul style="list-style-type: none"> • WITH: With automatic back door system • WITHOUT: Without automatic back door system
AUTO LIGHT	WITH ⇔ WITHOUT	—
DTRL	WITH ⇔ WITHOUT	<ul style="list-style-type: none"> • WITH: With daytime running light system • WITHOUT: Without daytime running light system
RAIN SENSOR	WITH ⇔ WITHOUT	—
THEFT ALM AREA	WITHOUT ⇔ MODE2	<ul style="list-style-type: none"> • WITHOUT: Without vehicle security system • MODE2: With vehicle security system
Key Fob Type	MODE7 ⇔ MODE9	<ul style="list-style-type: none"> • MODE7: With automatic back door system • MODE9: Without automatic back door system

⇔: Items which confirm vehicle specifications

AUTO SETTING ITEM		NOTE
Items	Setting value	
BATTERY SAVER FUNCTION	MODE3	—
Trunk/Glass Hatch select	Glass Hatch	Even on a vehicle without glass hatch. It displays "Glass Hatch".
TRANSIT MODE	WITH	—
ACC BAT SAVE FUNC	MODE2	—
TR OPEN SW (INT)	MODE1	—
H/L BULB	DEFAULT	—
FR FOG LAMP	WITH	—
RR FOG LAMP	WITH	Even on a vehicle without rear fog lamp. It displays "WITH".
DI LMP VARIAT	MODE2	—
LIGHT RECOG	MODE7	—
TRANSMISSION	AT with ABS	—
REAR WIPER	WITH	—
HAZARD SW TYPE	MODE1	—
TR CANCEL SW	WITHOUT	—
BCM AC CONTROL	MODE1	—
TRUNK ACT OUTPUT	MODE2	—
TPMS	WITH	—
TIRE PRESSURE	230kPa	—

INSPECTION AND ADJUSTMENT

< BASIC INSPECTION >

AUTO SETTING ITEM		NOTE
Items	Setting value	
RAIN SEN TYPE	MODE2	—
FOG ON WITH AUTO LIGHT	WITHOUT	—

FOR MEXICO

MANUAL SETTING ITEM		NOTE
Items	Setting value	
AV C/U	WITH	—
AUTO BACK DOOR	WITHOUT	—
AUTO LIGHT	WITH ⇔ WITHOUT	—
DTRL	WITHOUT	—
RAIN SENSOR	WITH ⇔ WITHOUT	—
THEFT ALM AREA	MODE2	—
HAZARD SW TYPE	MODE1	—

⇔: Items which confirm vehicle specifications

AUTO SETTING ITEM		NOTE
Items	Setting value	
BATTERY SAVER FUNCTION	MODE3	—
Trunk/Glass Hatch select	Glass Hatch	Even on a vehicle without glass hatch. It displays "Glass Hatch".
TRANSIT MODE	WITH	—
ACC BAT SAVE FUNC	MODE2	—
TR OPEN SW (INT)	MODE1	—
H/L BULB	DEFAULT	—
FR FOG LAMP	WITH	—
RR FOG LAMP	WITH	Even on a vehicle without rear fog lamp. It displays "WITH".
DI LMP VARIAT	MODE2	—
LIGHT RECOG	MODE7	—
TRANSMISSION	AT with ABS	—
REAR WIPER	WITH	—
TR CANCEL SW	WITHOUT	—
BCM AC CONTROL	MODE1	—
TRUNK ACT OUTPUT	MODE2	—
TPMS	WITHOUT	—
TIRE PRESSURE	240kPa	—
RAIN SEN TYPE	MODE2	—
FOG ON WITH AUTO LIGHT	WITHOUT	—
Key Fob Type	MODE9	—

SHIPPING MODE CANCEL OPERATION

< BASIC INSPECTION >

SHIPPING MODE CANCEL OPERATION

Description

INFOID:000000009722430

SYSTEM DIAGRAM

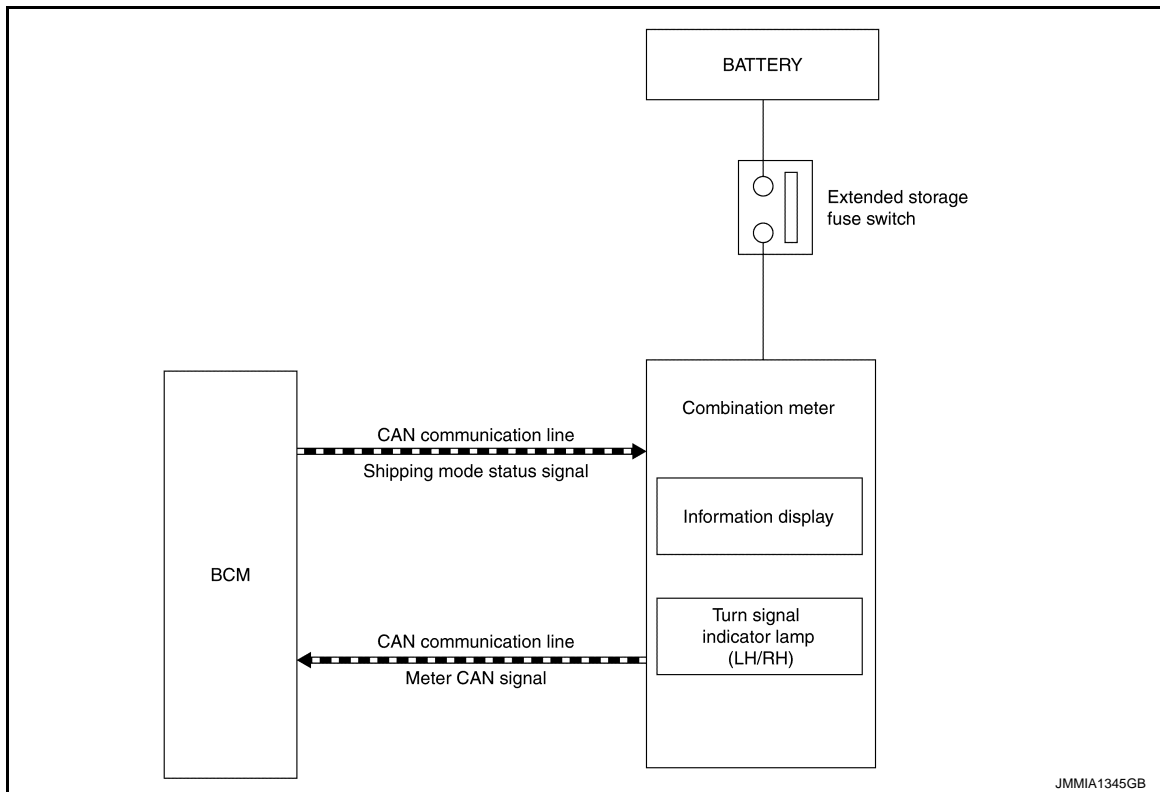

DESCRIPTION

- The combination meter transmits meter CAN signal*¹ to BCM via CAN communication, when the extended storage fuse switch is ON.
- BCM switches the status (shipping mode or normal mode) by itself according to the meter CAN signal*¹ from combination meter, and transmits shipping mode status signal to combination meter via CAN communication.
- The combination meter displays extended storage fuse warning message*² on the information display, and turns the turn signal indicator lamp (LH/RH) ON, when BCM is in shipping mode.
- BCM control functions are limited in shipping mode. Refer to [BCS-95. "Description"](#).

*1: Odometer signal, wake up signal and each signal.

*2: When shipping mode function operates, "SHIPPING MODE ON PUSH STORAGE FUSE" is displayed.

Work Procedure

INFOID:000000009722431

1. SHIPPING MODE CANCEL OPERATION

1. Turn ignition switch OFF.
2. Push in (switch on) the extended storage fuse switch. Refer to [PG-67. "Fuse"](#).
3. Turn ignition switch ON.
4. Turn ignition switch OFF and wait at least 2 seconds.

>> GO TO 2.

2. SHIPPING MODE CANCEL CHECK

1. Turn ignition switch ON.
2. Check that extended storage fuse warning message is not displays on information display.

>> WORK END

A
B
C
D
E
F
G
H
I
J
K
L
N
O
P

BCS

BODY CONTROL SYSTEM

< SYSTEM DESCRIPTION >

SYSTEM DESCRIPTION

BODY CONTROL SYSTEM

System Description

INFOID:000000009722432

OUTLINE

- BCM (Body Control Module) controls the various electrical components. It inputs the information required to the control from CAN communication and the signal received from each switch and sensor.
- BCM has combination switch reading function for reading the operation status of combination switches (light, turn signal, wiper and washer) in addition to a function for controlling the operation of various electrical components. It also has the signal transmission function as the passed point of signal and the power saving control function that reduces the power consumption with the ignition switch OFF.
- BCM is equipped with the diagnosis function that performs the diagnosis with CONSULT and various settings.

BCM CONTROL FUNCTION LIST

System	Reference
Combination switch reading system	BCS-10, "System Diagram"
Signal buffer system	BCS-14, "System Diagram"
Power consumption control system	BCS-15, "System Diagram"
Auto light system	EXL-14, "System Diagram"
Turn signal and hazard warning lamp system	<ul style="list-style-type: none"> • EXL-18, "System Diagram" (Xenon type headlamp) • EXL-205, "System Diagram" (Halogen type headlamp)
Headlamp system	<ul style="list-style-type: none"> • EXL-9, "System Diagram" (Xenon type headlamp) • EXL-197, "System Diagram" (Halogen type headlamp)
Parking, license plate and tail lamps system	<ul style="list-style-type: none"> • EXL-20, "System Diagram" (Xenon type headlamp) • EXL-207, "System Diagram" (Halogen type headlamp)
Front fog lamp system	<ul style="list-style-type: none"> • EXL-16, "System Diagram" (Xenon type headlamp) • EXL-203, "System Diagram" (Halogen type headlamp)
Exterior lamp battery saver system	<ul style="list-style-type: none"> • EXL-22, "System Diagram" (Xenon type headlamp) • EXL-209, "System Diagram" (Halogen type headlamp)
Daytime running light system	<ul style="list-style-type: none"> • EXL-12, "System Diagram" (Xenon type headlamp) • EXL-199, "System Diagram" (Halogen type headlamp)
Interior room lamp control system	INL-6, "System Diagram"
Step lamp system	
Interior room lamp battery saver system	INL-9, "System Diagram"
Front wiper and washer system	<ul style="list-style-type: none"> • WW-7, "WITH RAIN SENSOR : System Diagram" (With rain sensor) • WW-11, "WITHOUT RAIN SENSOR : System Diagram" (Without rain sensor)
Rear wiper and washer system	WW-16, "System Diagram"
Warning chime system	WCS-5, "WARNING CHIME SYSTEM : System Diagram"
Door lock system	DLK-14, "System Diagram"
Automatic back door system	DLK-44, "System Diagram"
Automatic drive positioner system	ADP-12, "AUTOMATIC DRIVE POSITIONER SYSTEM : System Diagram"
Nissan Vehicle Immobilizer System (NVIS) - NATS	SEC-14, "System Diagram"
Vehicle security system	SEC-19, "System Diagram"
Panic alarm	

BODY CONTROL SYSTEM

< SYSTEM DESCRIPTION >

System	Reference
Rear window defogger system	<ul style="list-style-type: none"> • DEF-4, "WITH BOSE SYSTEM : System Diagram" (With BOSE system) • DEF-6, "WITHOUT BOSE SYSTEM : System Diagram" (Without BOSE system)
Intelligent Key system/engine start system	DLK-18, "INTELLIGENT KEY SYSTEM : System Diagram"
Power window system	PWC-7, "System Diagram"
Retained accessory power (RAP) system	PWC-7, "System Description"
Tire pressure monitor system (TPMS) - AIR PRESSURE MONITOR	WT-8, "System Description"

Component Parts Location

INFOID:000000009722433

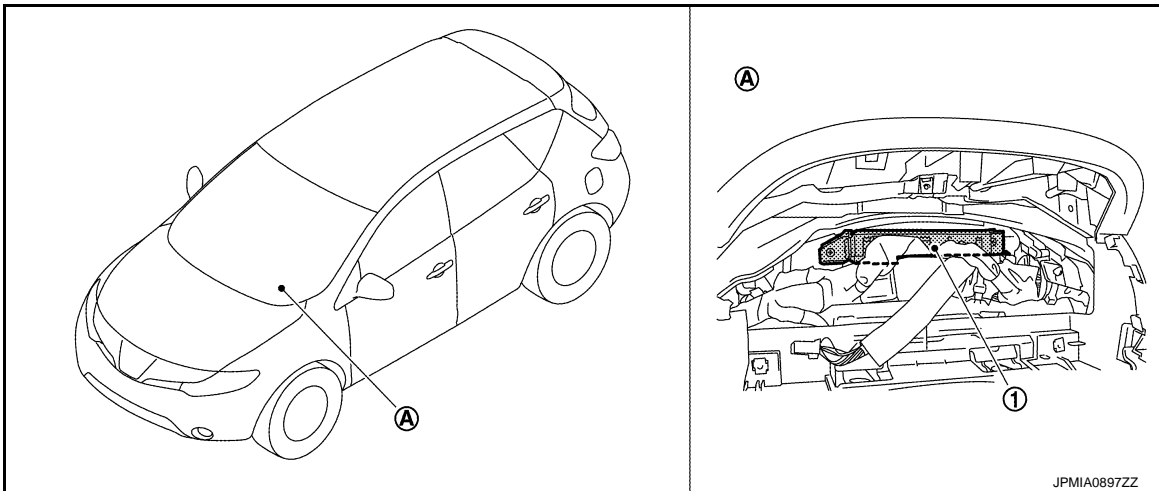

- 1. BCM
- A. Behind of combination meter

BCS

COMBINATION SWITCH READING SYSTEM

< SYSTEM DESCRIPTION >

COMBINATION SWITCH READING SYSTEM

System Diagram

INFOID:000000009722434

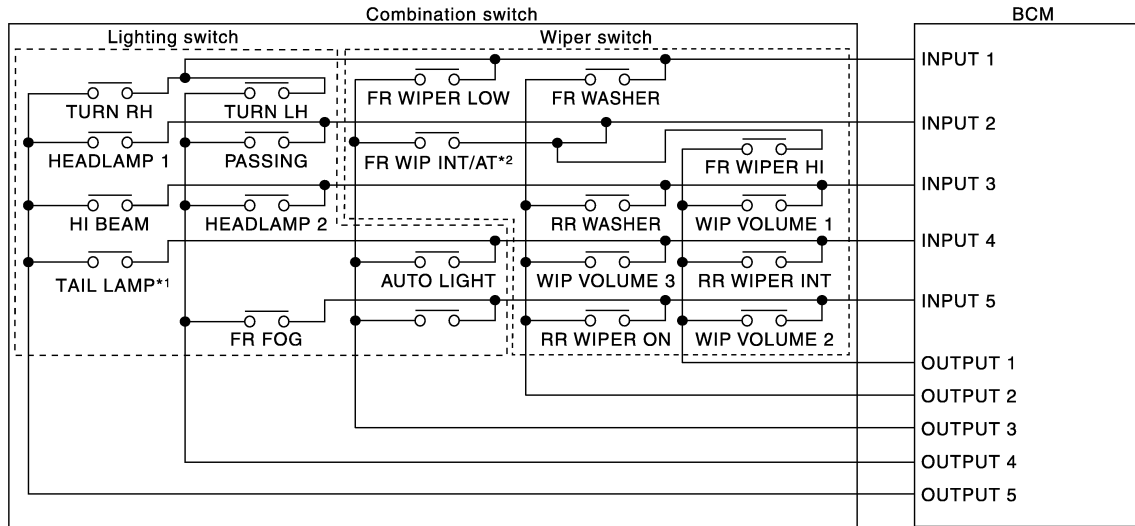

JMMIA0293GB

NOTE:

- *1: TAIL LAMP switch links lighting switch 1ST position.
- *2: "FR WIP INT/AT" is FR WIPER INT/AUTO.

System Description

INFOID:000000009722435

OUTLINE

- BCM reads the status of the combination switch (light, turn signal, wiper and washer) and recognizes the status of each switch.
- BCM is a combination of 5 output terminals (OUTPUT 1 - 5) and 5 input terminals (INPUT 1 - 5). It reads a maximum of 20 switch status.

COMBINATION SWITCH MATRIX

Combination switch circuit

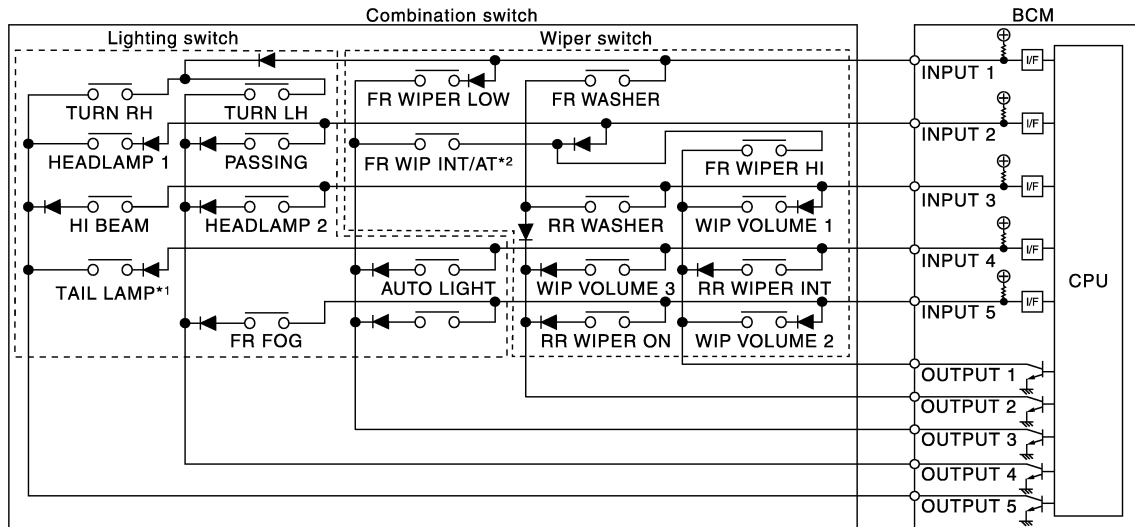

JMMIA0293GB

NOTE:

- *1: TAIL LAMP switch links lighting switch 1ST position.
- *2: "FR WIP INT/AT" is FR WIPER INT/AUTO.

COMBINATION SWITCH READING SYSTEM

< SYSTEM DESCRIPTION >

Combination switch INPUT-OUTPUT system list

System	OUTPUT 1	OUTPUT 2	OUTPUT 3	OUTPUT 4	OUTPUT 5
INPUT 1	—	FR WASHER	FR WIPER LOW	TURN LH	TURN RH
INPUT 2	FR WIPER HI	—	FR WIPER INT/ AUTO	PASSING	HEADLAMP 1
INPUT 3	WIP VOLUME 1	RR WASHER	—	HEADLAMP 2	HI BEAM
INPUT 4	RR WIPER INT	WIP VOLUME 3	AUTO LIGHT	—	TAIL LAMP
INPUT 5	WIP VOLUME 2	RR WIPER ON	—	FR FOG	—

NOTE:

Headlamp has a dual system switch.

COMBINATION SWITCH READING FUNCTION

Description

- BCM reads the status of the combination switch at 10 ms interval normally.

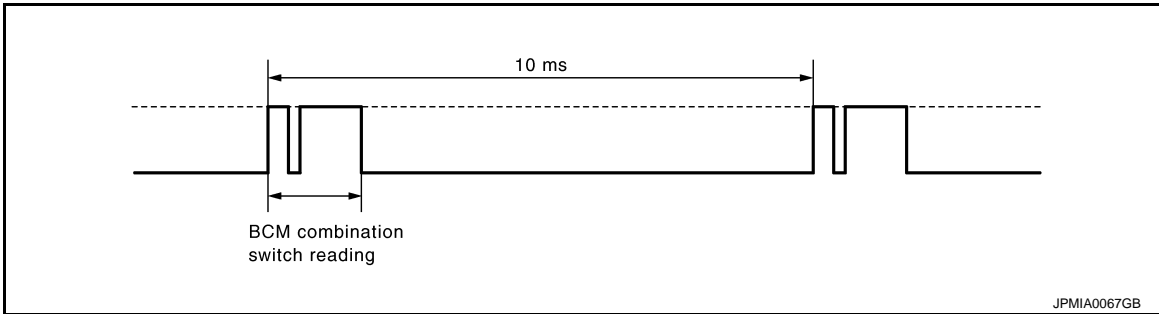

NOTE:

BCM reads the status of the combination switch at 60 ms interval when BCM is controlled at low power consumption mode.

- BCM operates as follows and judges the status of the combination switch.
 - INPUT 1 - 5 outputs the voltage waveforms of 5 systems simultaneously.
 - It operates the transistor on OUTPUT side in the following order: OUTPUT 5 → 4 → 3 → 2 → 1.
 - The voltage waveform of INPUT corresponding to the formed circuit changes according to the operation of the transistor on OUTPUT side if any (1 or more) switches are ON.
 - It reads this change of the voltage as the status signal of the combination switch.

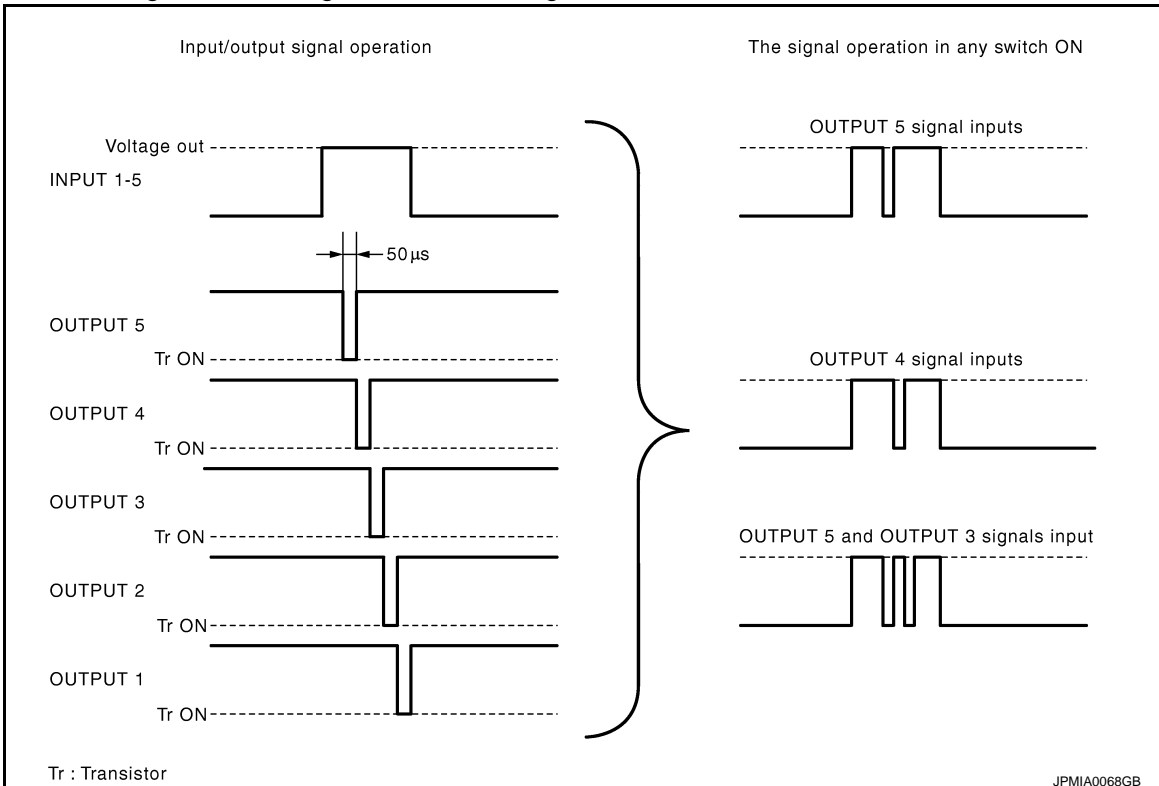

COMBINATION SWITCH READING SYSTEM

< SYSTEM DESCRIPTION >

Operation Example

In the following operation example, the combination of the status signals of the combination switch is replaced as follows: INPUT 1 - 5 to "1 - 5" and OUTPUT 1 - 5 to "A - E".

Example 1: When a switch (TURN RH switch) is turned ON

- The circuit between INPUT 1 and OUTPUT 5 is formed when the TURN RH switch is turned ON.

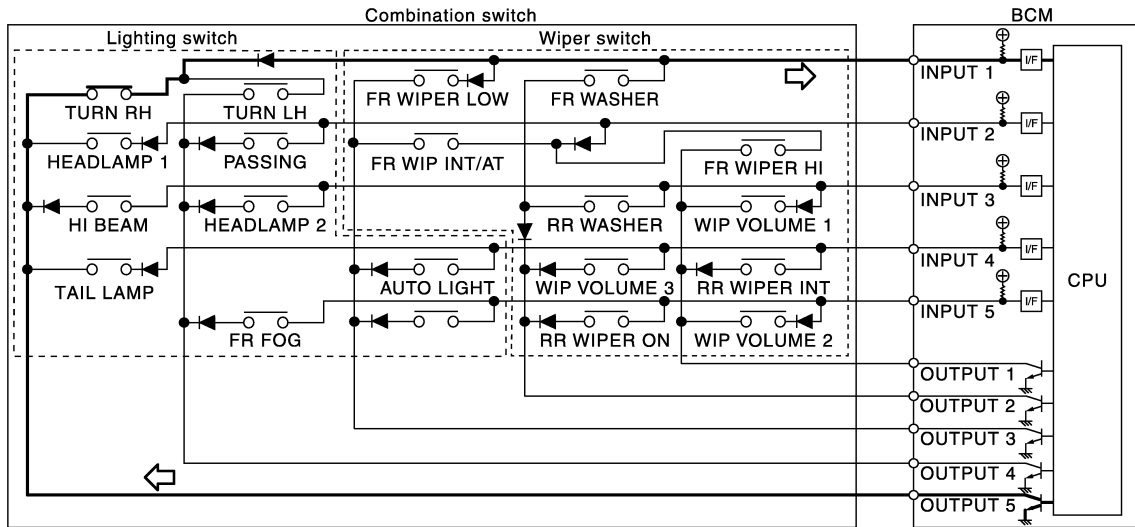

- BCM detects the combination switch status signal "1E" when the signal of OUTPUT 5 is input to INPUT 1.
- BCM judges that the TURN RH switch is ON when the signal "1E" is detected.

Example 2: When some switches (turn RH switch, front wiper LO switch) are turned ON

- The circuits between INPUT 1 and OUTPUT 5 and between INPUT 1 and OUTPUT 3 are formed when the TURN RH switch and FR WIPER LOW switch are turned ON.

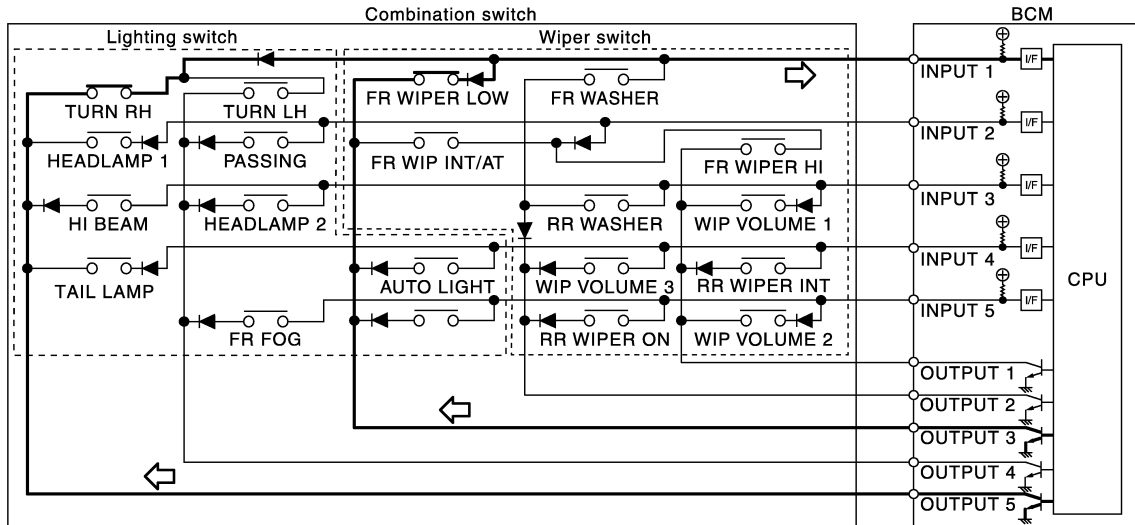

- BCM detects the combination switch status signal "1CE" when the signals of OUTPUT 3 and OUTPUT 5 are input to INPUT 1.
- BCM judges that the TURN RH switch and FR WIPER LOW switch are ON when the signal "1CE" is detected.

WIPER VOLUME DIAL POSITION

BCM judges the wiper volume dial 1 - 7 by the status of WIP VOLUME 1, 2 and 3 switches.

Wiper volume dial position	Switch status		
	WIP VOLUME 1	WIP VOLUME 2	WIP VOLUME 3
1	ON	ON	ON
2	ON	ON	OFF

COMBINATION SWITCH READING SYSTEM

< SYSTEM DESCRIPTION >

Wiper volume dial position	Switch status		
	WIP VOLUME 1	WIP VOLUME 2	WIP VOLUME 3
3	ON	OFF	OFF
4	OFF	OFF	OFF
5	OFF	OFF	ON
6	OFF	ON	ON
7	OFF	ON	OFF

NOTE:

For details of wiper volume dial position, refer to [WW-7. "WITH RAIN SENSOR : System Description"](#) (with rain sensor), [WW-11. "WITHOUT RAIN SENSOR : System Description"](#) (without rain sensor).

A
B
C
D
E
F
G
H
I
J
K
L
N
O
P

BCS

SIGNAL BUFFER SYSTEM

< SYSTEM DESCRIPTION >

SIGNAL BUFFER SYSTEM

System Diagram

INFOID:000000009722436

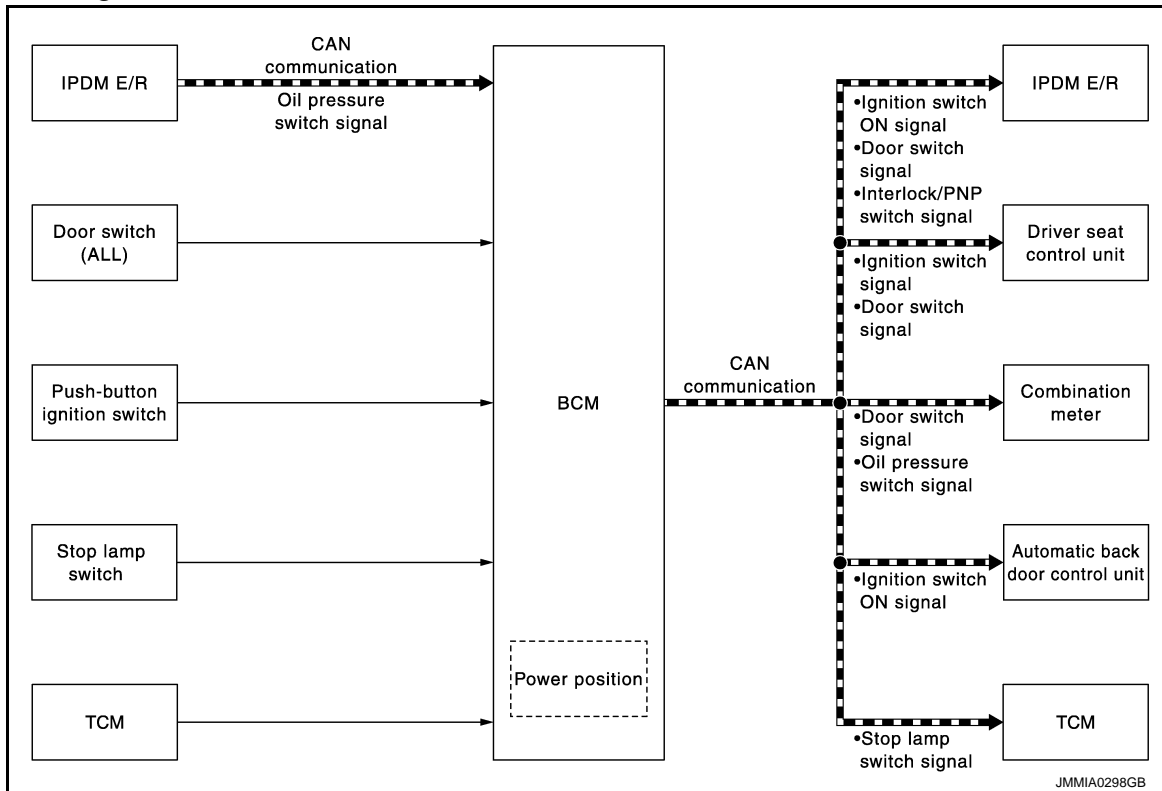

JMMA0298GB

System Description

INFOID:000000009722437

OUTLINE

BCM has the signal transmission function that outputs/transmits each input/received signal to each unit.

Signal transmission function list

Signal name	Input	Output	Description
<ul style="list-style-type: none"> Ignition switch ON signal Ignition switch signal 	Push-button ignition switch (Push switch)	<ul style="list-style-type: none"> IPDM E/R (CAN) Driver seat control unit (CAN) Automatic back door control unit (CAN) 	Inputs the push-button ignition switch (push switch) signal and transmits the ignition switch status judged with BCM via CAN communication.
Door switch signal	Any door switch	<ul style="list-style-type: none"> Combination meter (CAN) IPDM E/R (CAN) Driver seat control unit (CAN) 	Inputs the door switch signal and transmits it via CAN communication.
Oil pressure switch signal	IPDM E/R (CAN)	Combination meter (CAN)	Transmits the received oil pressure switch signal via CAN communication.
Stop lamp switch signal	<ul style="list-style-type: none"> Stop lamp switch ICC brake hold relay (With ICC) 	TCM (CAN)	Inputs the stop lamp switch 1 signal, and stop lamp switch 2 signal or ICC brake hold relay (with ICC) signal, and transmits it via CAN communication.
Interlock/PNP switch signal	TCM	IPDM E/R (CAN)	Inputs the selector lever P/N position signal, and transmits the interlock/PNP switch signal via CAN communication.

POWER CONSUMPTION CONTROL SYSTEM

< SYSTEM DESCRIPTION >

POWER CONSUMPTION CONTROL SYSTEM

System Diagram

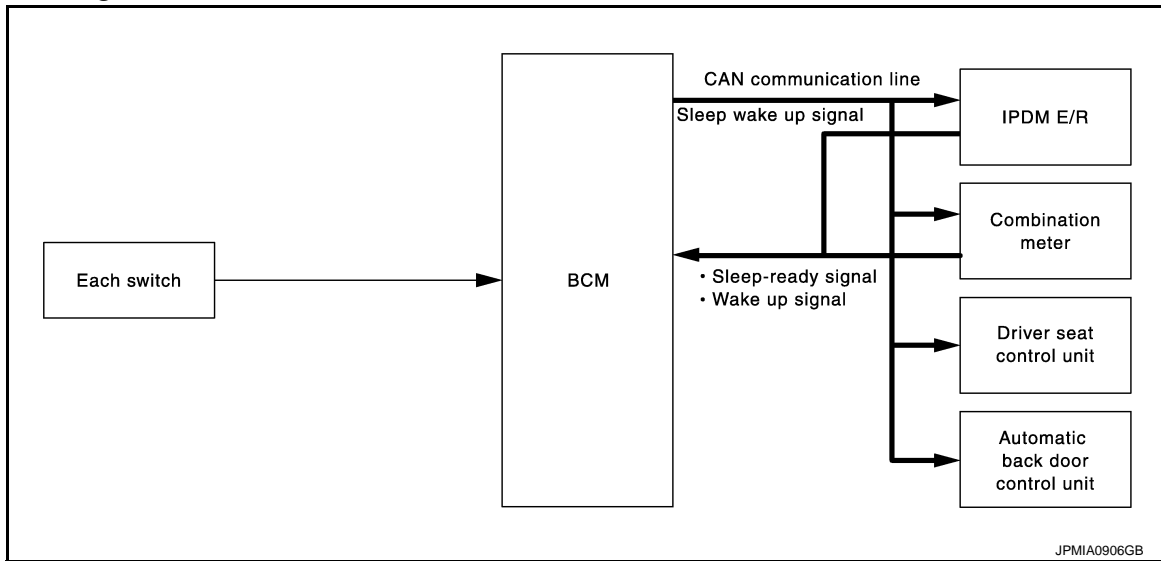

System Description

INFOID:000000009722439

OUTLINE

- BCM incorporates a power saving control function that reduces the power consumption according to the vehicle status.
- BCM switches the status (control mode) by itself with the power saving control function. It performs the sleep request to each unit (IPDM E/R, combination meter, driver seat control unit and automatic back door control unit) that operates with the ignition switch OFF.

Normal mode (wake-up)

- CAN communication is normally performed with other units
- Each control with BCM is operating properly

CAN communication sleep mode (CAN sleep)

- CAN transmission is stopped
- Control with BCM only is operating

Low power consumption mode (BCM sleep)

- Low power consumption control is active
- CAN transmission is stopped

LOW POWER CONSUMPTION CONTROL WITH BCM

BCM reduces the power consumption with the following operation in the low power consumption mode.

- The reading interval of the each switches changes from 10 ms interval to 60 ms interval.

Sleep mode activation

- BCM receives the sleep-ready signal (ready) from IPDM E/R and combination meter via CAN communication.
- BCM transmits the sleep wake up signal (sleep) to each unit when all of the CAN sleep conditions are fulfilled.
- Each unit stops the transmission of CAN communication with the sleep wake up signal. BCM is in CAN communication sleep mode.
- BCM is in the low power consumption mode and perform the low power consumption control when all of the BCM sleep conditions are fulfilled with CAN sleep condition.

A
B
C
D
E
F
G
H
I
J
K
L
N
O
P

BCS

POWER CONSUMPTION CONTROL SYSTEM

< SYSTEM DESCRIPTION >

Sleep condition

CAN sleep condition	BCM sleep condition
<ul style="list-style-type: none"> • Receiving the sleep-ready signal (ready) from all units • Ignition switch: OFF • Vehicle security system and panic alarm: Not operation • Warning chime: Not operation • Intelligent Key system buzzer: Not operation • Stop lamp switch: OFF • Key slot (card switch) status: No change • Turn signal indicator lamp: Not operation • Exterior lamp: OFF • Door lock status: No change • CONSULT communication status: Not communication • Meter display signal: Non-transmission • Door switch status: No change • Rear window defogger: OFF • Auto back door: Not operation 	<ul style="list-style-type: none"> • Interior room lamp battery saver: Time out • RAP system: OFF • Power window switch communication: No transmission • Push-button ignition switch illumination: OFF • Nissan Vehicle Immobilizer System (NVIS) - NATS: Not operation • Remote keyless entry receiver communication status: No communication • Tire pressure monitor system (TPMS) - AIR PRESSURE MONITOR: Stop • LOCK indicator lamp: Not operation • ACC indicator lamp: Not operation • ON indicator lamp: Not operation

Wake-up operation

- BCM changes from the low power consumption mode to the CAN communication sleep mode when the any of the BCM wake-up conditions is fulfilled. Only the control with BCM is activated.
- BCM transmits the sleep wake up signal (wake up) to each unit when any of the CAN wake-up conditions is fulfilled. It changes from the low power consumption mode or the CAN communication sleep mode to the normal mode.
- Each unit starts the transmission of CAN communication with the sleep wake up signal. In addition, the combination meter transmits the wake up signal to BCM via CAN communication to report the CAN communication start.

Wake-up condition

BCM wake-up condition	CAN wake-up condition
<ul style="list-style-type: none"> • Power window switch communication: Receiving • Remote keyless entry receiver communication: Receiving 	<ul style="list-style-type: none"> • Receiving the sleep-ready signal (Not-ready) from any units • Key slot (key switch): OFF → ON, ON → OFF • Push-button ignition switch (push switch): OFF→ ON • Hazard switch: OFF → ON • PASSING switch: OFF → ON, ON → OFF • TAIL LAMP switch: OFF → ON • Driver door switch: OFF → ON, ON → OFF • Passenger door switch: OFF → ON, ON → OFF • Rear RH door switch: OFF → ON, ON → OFF • Rear LH door switch: OFF → ON, ON → OFF • Back door switch: OFF → ON, ON → OFF • Driver door request switch: OFF → ON • Passenger door request switch: OFF → ON • Back door request switch: OFF → ON • Stop lamp switch: ON

POWER CONSUMPTION CONTROL SYSTEM

< SYSTEM DESCRIPTION >

Component Parts Location

INFOID:000000009722440

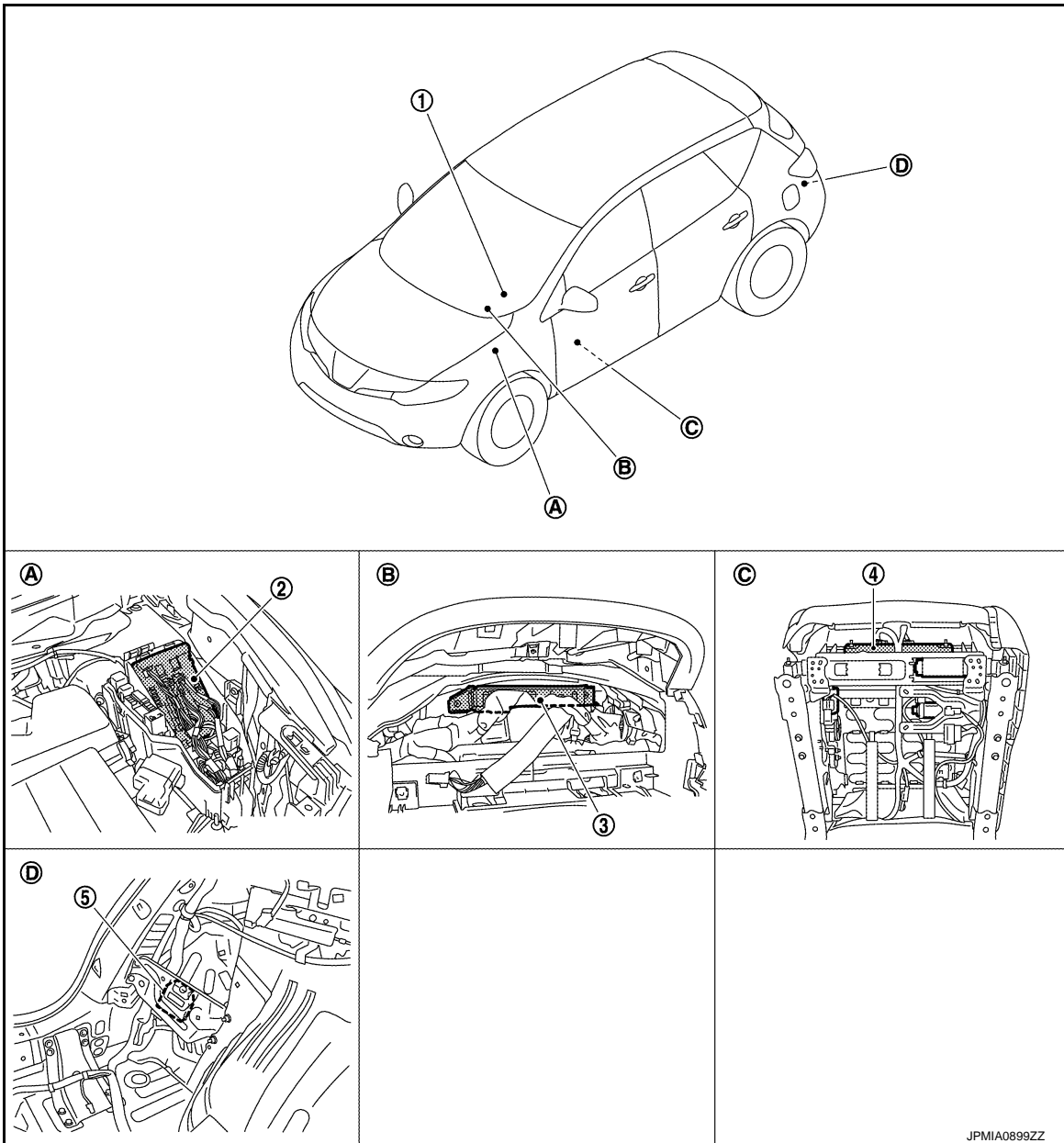

- | | | |
|-------------------------------------|-------------------------------------|-----------------------------------------------|
| 1. Combination meter | 2. IPDM E/R | 3. BCM |
| 4. Driver seat control unit | 5. Automatic back door control unit | |
| A. Engine room (LH) | B. Behind of combination meter | C. Backside of the seat cushion (driver seat) |
| D. Dash side lower (Passenger side) | | |

A
B
C
D
E
F
G
H
I
J
K
L
N
O
P

BCS

DIAGNOSIS SYSTEM (BCM)

< SYSTEM DESCRIPTION >

DIAGNOSIS SYSTEM (BCM)

COMMON ITEM

COMMON ITEM : CONSULT Function (BCM - COMMON ITEM)

INFOID:000000009722441

APPLICATION ITEM

CONSULT performs the following functions via CAN communication with BCM.

Diagnosis mode	Function Description
Work Support	Changes the setting for each system function.
Self Diagnostic Result	Displays the diagnosis results judged by BCM.
CAN Diag Support Monitor	Monitors the reception status of CAN communication viewed from BCM.
Data Monitor	The BCM input/output signals are displayed.
Active Test	The signals used to activate each device are forcibly supplied from BCM.
Ecu Identification	The BCM part number is displayed.
Configuration	<ul style="list-style-type: none"> Read and save the vehicle specification. Write the vehicle specification when replacing BCM.

SYSTEM APPLICATION

BCM can perform the following functions for each system.

NOTE:

It can perform the diagnosis modes except the following for all sub system selection items.

×: Applicable item

System	Sub system selection item	Diagnosis mode		
		Work Support	Data Monitor	Active Test
Door lock	DOOR LOCK	×	×	×
Rear window defogger	REAR DEFOGGER		×	×
Warning chime	BUZZER		×	×
Interior room lamp timer	INT LAMP	×	×	×
Exterior lamp	HEAD LAMP	×	×	×
Wiper and washer	WIPER	×*1	×	×
Turn signal and hazard warning lamps	FLASHER	×	×	×
—	AIR CONDITONER*2			
<ul style="list-style-type: none"> Intelligent Key system Engine start system 	INTELLIGENT KEY	×	×	×
Combination switch	COMB SW		×	
Body control system	BCM	×		
NVIS - NATS	IMMU		×	×
Interior room lamp battery saver	BATTERY SAVER	×	×	×
Back door opener system	TRUNK		×	×
Vehicle security system	THEFT ALM	×	×	×
RAP system	RETAINED PWR		×	
Signal buffer system	SIGNAL BUFFER		×	×
TPMS	TPMS (AIR PRESSURE MONITOR)	×	×	×

NOTE:

- *1: For models with rain sensor this mode is displayed, but is not used.
- *2: This item is displayed, but is not used.

FREEZE FRAME DATA (FFD)

DIAGNOSIS SYSTEM (BCM)

< SYSTEM DESCRIPTION >

The BCM records the following vehicle condition at the time a particular DTC is detected, and displays on CONSULT.

CONSULT screen item	Indication/Unit	Description	
Vehicle Speed	km/h	Vehicle speed of the moment a particular DTC is detected	
Odo/Trip Meter	km	Total mileage (Odometer value) of the moment a particular DTC is detected	
Vehicle Condition	SLEEP>LOCK	Power position status of the moment a particular DTC is detected	While turning BCM status from low power consumption mode to normal mode (Power supply position is "LOCK"*)
	SLEEP>OFF		While turning BCM status from low power consumption mode to normal mode (Power supply position is "OFF".)
	LOCK>ACC		While turning power supply position from "LOCK" to "ACC"
	ACC>ON		While turning power supply position from "ACC" to "IGN"
	RUN>ACC		While turning power supply position from "RUN" to "ACC" (Vehicle is stopping and selector lever is except P position.)
	CRANK>RUN		While turning power supply position from "CRANKING" to "RUN" (From cranking up the engine to run it)
	RUN>URGENT		While turning power supply position from "RUN" to "ACC" (Emergency stop operation)
	ACC>OFF		While turning power supply position from "ACC" to "OFF"
	OFF>LOCK		While turning power supply position from "OFF" to "LOCK"*
	OFF>ACC		While turning power supply position from "OFF" to "ACC"
	ON>CRANK		While turning power supply position from "IGN" to "CRANKING"
	OFF>SLEEP		While turning BCM status from normal mode (Power supply position is "OFF".) to low power consumption mode
	LOCK>SLEEP		While turning BCM status from normal mode (Power supply position is "LOCK"*) to low power consumption mode
	LOCK		Power supply position is "LOCK"*
	OFF		Power supply position is "OFF" (Ignition switch OFF)
	ACC		Power supply position is "ACC" (Ignition switch ACC)
	ON		Power supply position is "IGN" (Ignition switch ON with engine stopped)
ENGINE RUN	Power supply position is "RUN" (Ignition switch ON with engine running)		
CRANKING	Power supply position is "CRANKING" (At engine cranking)		
IGN Counter	0 - 39	The number of times that ignition switch is turned ON after DTC is detected <ul style="list-style-type: none"> • The number is 0 when a malfunction is detected now. • The number increases like 1 → 2 → 3...38 → 39 after returning to the normal condition whenever ignition switch OFF → ON. • The number is fixed to 39 until the self-diagnosis results are erased if it is over 39. 	

NOTE:

*: Power supply position shifts to "LOCK" from "OFF", when ignition switch is in the OFF position, selector lever is in the P position, and any of the following conditions are met.

- Closing door
- Opening door
- Door is locked using door request switch
- Door is locked using Intelligent Key

The power supply position shifts to "ACC" when the push-button ignition switch (push switch) is pushed at "LOCK".

DOOR LOCK

DOOR LOCK : CONSULT Function (BCM - DOOR LOCK)

INFOID:000000010074029

BCM CONSULT FUNCTION

CONSULT performs the following functions via CAN communication with BCM.

DIAGNOSIS SYSTEM (BCM)

< SYSTEM DESCRIPTION >

Diagnosis mode	Function Description
WORK SUPPORT	Changes the setting for each system function.
DATA MONITOR	The BCM input/output signals are displayed.
ACTIVE TEST	The signals used to activate each device are forcibly supplied from BCM.

WORK SUPPORT

Monitor item	Description
DOOR LOCK-UNLOCK SET	Selective unlock function mode can be changed to operate (WITH) or not operate (WITHOUT) with this mode.
AUTOMATIC DOOR LOCK SELECT	Automatic door lock function mode can be selected from the following in this mode. <ul style="list-style-type: none"> VH SPD: All doors are locked when vehicle speed more than 24km/h (15MPH) P RANGE: All doors are locked when shifting the selector lever from P position to other than the P position
AUTOMATIC DOOR UNLOCK SELECT	Automatic door unlock function mode can be selected from the following in the mode. <ul style="list-style-type: none"> MODE 1: All doors are unlocked when the power supply position is changed from ON to OFF MODE 2: All doors are unlocked when shifting the selector lever from any position other than the P to P position MODE 3: Driver side door is unlocked when the power supply position is changed from ON to OFF MODE 4: Driver side door is unlocked when shifting the selector lever from any position other than the P to P position
AUTOMATIC LOCK/UNLOCK SET	Automatic door lock/unlock function mode can be selected from the following in this mode. <ul style="list-style-type: none"> Off: non-operational Unlock Only: door unlock operation only Lock Only: door lock operation only Lock/Unlock: lock/unlock operation

DATA MONITOR

NOTE:

The following table includes information (items) inapplicable to this vehicle. For information (items) applicable to this vehicle, refer to CONSULT display items.

Monitor Item	Contents
REQ SW-DR	Indicated [ON/OFF] condition of door request switch (driver side).
REQ SW-AS	Indicated [ON/OFF] condition of door request switch (passenger side).
REQ SW-BD/TR	Indicated [ON/OFF] condition of back door request switch.
DOOR SW-DR	Indicated [ON/OFF] condition of front door switch (driver side).
DOOR SW-AS	Indicated [ON/OFF] condition of front door switch (passenger side).
DOOR SW-RR	Indicated [ON/OFF] condition of rear door switch RH.
DOOR SW-RL	Indicated [ON/OFF] condition of rear door switch LH.
DOOR SW-BK	Indicated [ON/OFF] condition of back door switch.
CDL LOCK SW	Indicated [ON/OFF] condition of lock signal from door lock unlock switch.
CDL UNLOCK SW	Indicated [ON/OFF] condition of unlock signal from door lock unlock switch.
KEY CYL LK-SW	Indicated [ON/OFF] condition of lock signal from door key cylinder.
KEY CYL UN-SW	Indicated [ON/OFF] condition of unlock signal from door key cylinder.

ACTIVE TEST

DIAGNOSIS SYSTEM (BCM)

< SYSTEM DESCRIPTION >

Test item	Description
DOOR LOCK	This test is able to check door lock/unlock operation. <ul style="list-style-type: none">• The all door lock actuators are locked when "ALL LCK" on CONSULT screen is touched.• The all door lock actuators are unlocked when "ALL UNLK" on CONSULT screen is touched.• The door lock actuator (driver side) is unlocked when "DR UNLK" on CONSULT screen is touched.• The door lock actuator (passenger side) is unlocked when "AS UNLK" on CONSULT screen is touched.• The door lock actuator (rear LH and RH) is unlocked when "OTR ULK" on CONSULT screen is touched.

REAR WINDOW DEFOGGER

REAR WINDOW DEFOGGER : CONSULT Function (BCM - REAR DEFOGGER)

INFOID:000000010074043

DATA MONITOR

NOTE:

The following table includes information (items) inapplicable to this vehicle. For information (items) applicable to this vehicle, refer to CONSULT display items.

Monitor Item	Description
REAR DEF SW	This is displayed even when it is not equipped.
PUSH SW	Indicates [ON/OFF] condition of push switch.

ACTIVE TEST

Test Item	Description
REAR DEFOGGER	Rear window defogger operates when "ON" on CONSULT screen is touched.

BUZZER

BUZZER : CONSULT Function (BCM - BUZZER)

INFOID:000000010074044

CONSULT APPLICATION ITEMS

Test item	Diagnosis mode	Description
BUZZER	Data Monitor	Displays BCM input data in real time.
	Active Test	Operation of electrical loads can be checked by sending driving signal to them.

DATA MONITOR

NOTE:

The following table includes information (items) inapplicable to this vehicle. For information (items) applicable to this vehicle, refer to CONSULT display items.

Display item [Unit]	Description
PUSH SW [On/Off]	Status of push button ignition switch judged by BCM.
UNLK SEN-DR [On/Off]	Status of unlock sensor judged by BCM.
VEH SPEED 1 [Km/h]	Value of vehicle speed signal received from ABS actuator and electric unit (control unit) with CAN communication line.
KEY SW-SLOT [On/Off]	Status of key slot judged by BCM.
TAIL LAMP SW [On/Off]	Status of each switch judged by BCM using the combination switch readout function.

A
B
C
D
E
F
G
H
I
J
K
L
BCS
N
O
P

DIAGNOSIS SYSTEM (BCM)

< SYSTEM DESCRIPTION >

Display item [Unit]	Description
FR FOG SW [On/Off]	Status of front fog lamp switch judged by BCM.
DOOR SW-DR [On/Off]	Status of driver side door switch judged by BCM.

ACTIVE TEST

Display item [Unit]	Description
IGN KEY WARN ALM	The key warning chime operation can be checked by operating the relevant function (On/Off).
SEAT BELT WARN TEST	The seat belt warning chime operation can be checked by operating the relevant function (On/Off).
ID REGIST WARNING	The ID regist warning chime operation can be checked by operating the relevant function (On/Off).
LIGHT WARN ALM	The light warning chime operation can be checked by operating the relevant function (On/Off).

INT LAMP

INT LAMP : CONSULT Function (BCM - INT LAMP)

INFOID:0000000010074039

WORK SUPPORT

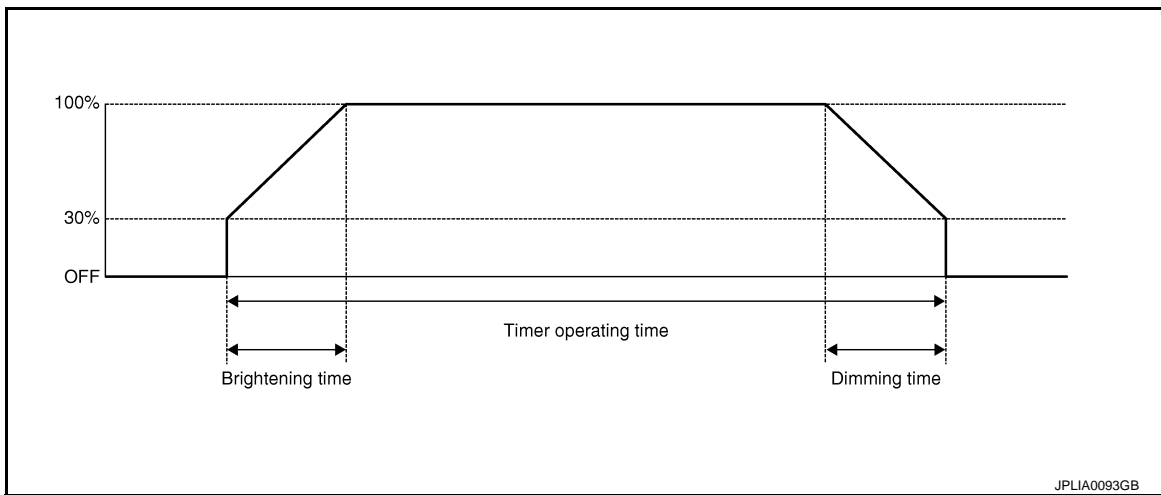

JPLIA0093GB

Service item	Setting item	Setting
SET I/L D-UNLCK INTCON	ON*	With the interior room lamp timer function
	OFF	Without the interior room lamp timer function
ROOM LAMP TIMER SET	MODE 2	7.5 sec.
	MODE 3*	15 sec.
	MODE 4	30 sec.
ROOM LAMP ON TIME SET	MODE 1	0.5 sec.
	MODE 2*	1 sec.
	MODE 3	2 sec.
	MODE 4	3 sec.
	MODE 5	0 sec.
ROOM LAMP OFF TIME SET	MODE 1	0.5 sec.
	MODE 2	1 sec.
	MODE 3	2 sec.
	MODE 4*	3 sec.
	MODE 5	0 sec.

DIAGNOSIS SYSTEM (BCM)

< SYSTEM DESCRIPTION >

Service item	Setting item	Setting
R LAMP TIMER LOGIC SET	MODE 1*	Interior room lamp timer activates with synchronizing all doors.
	MODE 2	Interior room lamp timer activates with synchronizing the driver door only.

*: Factory setting

DATA MONITOR

NOTE:

The following table includes information (items) inapplicable to this vehicle. For information (items) applicable to this vehicle, refer to CONSULT display items.

Monitor item [Unit]	Description
REQ SW-DR [On/Off]	The switch status input from request switch (driver side)
REQ SW-AS [On/Off]	The switch status input from front request switch (passenger side)
PUSH SW [On/Off]	The switch status input from push-button ignition switch
KEY SW-SLOT [On/Off]	Key switch status input from key slot
DOOR SW-DR [On/Off]	The switch status input from front door switch (driver side)
DOOR SW-AS [On/Off]	The switch status input from front door switch (passenger side)
DOOR SW-RR [On/Off]	The switch status input from rear door switch RH
DOOR SW-RL [On/Off]	The switch status input from rear door switch LH
DOOR SW-BK [On/Off]	NOTE: The item is indicated, but not monitored.
CDL LOCK SW [On/Off]	Lock switch status received from door lock/unlock switch by power window switch serial link
CDL UNLOCK SW [On/Off]	Unlock switch status received from door lock/unlock switch by power window switch serial link
KEY CYL LK-SW [On/Off]	Lock switch status received from key cylinder lock/unlock switch by power window switch serial link
KEY CYL UN-SW [On/Off]	Unlock switch status received from key cylinder lock/unlock switch by power window switch serial link
BACK DOOR SW [On/Off]	The switch status input from back door switch
RKE-LOCK [On/Off]	Lock signal status received from remote keyless entry receiver
RKE-UNLOCK [On/Off]	Unlock signal status received from remote keyless entry receiver

ACTIVE TEST

Test item	Operation	Description
INT LAMP	On	Outputs the interior room lamp control signal to turn map lamp and personal lamp ON (Map lamp switch is in DOOR position).
	Off	Stops the interior room lamp control signal to turn map lamp and personal lamp OFF.
STEP LAMP TEST	On	Outputs the step lamp control signal to turn step lamp ON.
	Off	Stops the step lamp control signal to turn step lamp OFF.

DIAGNOSIS SYSTEM (BCM)

< SYSTEM DESCRIPTION >

Test item	Operation	Description
LUGGAGE LAMP TEST	On	NOTE: The item is displayed, but cannot be tested.
	Off	

HEADLAMP

HEADLAMP : CONSULT Function (BCM - HEAD LAMP)

INFOID:000000010074035

WORK SUPPORT

Service item	Setting item	Setting
BATTERY SAVER SET	On*	With the exterior lamp battery saver function
	Off	Without the exterior lamp battery saver function
ILL DELAY SET	MODE 1*	45 sec.
	MODE 2	Without the function
	MODE 3	30 sec.
	MODE 4	60 sec.
	MODE 5	90 sec.
	MODE 6	120 sec.
	MODE 7	150 sec.
	MODE 8	180 sec.
		Sets delay timer function timer operation time. (All doors closed)
CUSTOM A/LIGHT SETTING	MODE 1*	Normal
	MODE 2	More sensitive setting than normal setting (Turns ON earlier than normal operation.)
	MODE 3	More sensitive setting than MODE 2 (Turns ON earlier than MODE 2.)
	MODE 4	Less sensitive setting than normal setting (Turns ON later than normal operation.)

*: Factory setting

DATA MONITOR

NOTE:

The following table includes information (items) inapplicable to this vehicle. For information (items) applicable to this vehicle, refer to CONSULT display items.

Monitor item [Unit]	Description
PUSH SW [On/Off]	The switch status input from push-button ignition switch
ENGINE STATE [Stop/Stall/Crank/Run]	The engine status received from ECM with CAN communication
VEH SPEED 1 [km/h]	The value of the vehicle speed received from combination meter with CAN communication
KEY SW-SLOT [On/Off]	Key switch status input from key slot

DIAGNOSIS SYSTEM (BCM)

< SYSTEM DESCRIPTION >

Monitor item [Unit]	Description	
TURN SIGNAL R [On/Off]	Each switch status that BCM detects from the combination switch reading function	A
TURN SIGNAL L [On/Off]		B
TAIL LAMP SW [On/Off]		C
HI BEAM SW [On/Off]		D
HEAD LAMP SW1 [On/Off]		E
HEAD LAMP SW2 [On/Off]		F
PASSING SW [On/Off]		G
AUTO LIGHT SW [On/Off]		H
FR FOG SW [On/Off]		I
RR FOG SW [On/Off]	NOTE: The item is indicated, but not monitored.	J
DOOR SW-DR [On/Off]	The switch status input from front door switch (driver side)	K
DOOR SW-AS [On/Off]	The switch status input from front door switch (passenger side)	L
DOOR SW-RR [On/Off]	The switch status input from rear door switch RH	
DOOR SW-RL [On/Off]	The switch status input from rear door switch LH	
DOOR SW-BK [On/Off]	NOTE: The item is indicated, but not monitored.	
OPTICAL SENSOR [V]	The value of exterior brightness voltage input from the optical sensor	

ACTIVE TEST

Test item	Operation	Description	
TAIL LAMP	On	Transmits the position light request signal to IPDM E/R with CAN communication to turn the tail lamp ON.	BCS
	Off	Stops the position light request signal transmission.	
HEAD LAMP	Hi	Transmits the high beam request signal with CAN communication to turn the headlamp (HI).	N
	Low	Transmits the low beam request signal with CAN communication to turn the headlamp (LO).	O
	Off	Stops the high & low beam request signal transmission.	
FR FOG LAMP	On	Transmits the front fog light request signal to IPDM E/R with CAN communication to turn the front fog lamp ON.	P
	Off	Stops the front fog light request signal transmission.	
RR FOG LAMP	On	NOTE: The item is indicated, but cannot be tested.	
	Off		
DAYTIME RUNNING LIGHT	On	NOTE: The item is indicated, but cannot be tested.	
	Off		

DIAGNOSIS SYSTEM (BCM)

< SYSTEM DESCRIPTION >

Test item	Operation	Description
CORNERING LAMP	RH	NOTE: The item is indicated, but cannot be tested.
	LH	
	Off	
ILL DIM SIGNAL	On	NOTE: The item is indicated, but cannot be tested.
	Off	

HEADLAMP : CONSULT Function (BCM - HEAD LAMP)

INFOID:000000010074036

WORK SUPPORT

Service item	Setting item	Setting
BATTERY SAVER SET	On*	With the exterior lamp battery saver function
	Off	Without the exterior lamp battery saver function
ILL DELAY SET	MODE 1*	45 sec.
	MODE 2	Without the function
	MODE 3	30 sec.
	MODE 4	60 sec.
	MODE 5	90 sec.
	MODE 6	120 sec.
	MODE 7	150 sec.
	MODE 8	180 sec.
		Sets delay timer function timer operation time. (All doors closed)
CUSTOM A/LIGHT SETTING	MODE 1*	Normal
	MODE 2	More sensitive setting than normal setting (Turns ON earlier than normal operation.)
	MODE 3	More sensitive setting than MODE 2 (Turns ON earlier than MODE 2.)
	MODE 4	Less sensitive setting than normal setting (Turns ON later than normal operation.)

*: Factory setting

DATA MONITOR

NOTE:

The following table includes information (items) inapplicable to this vehicle. For information (items) applicable to this vehicle, refer to CONSULT display items.

Monitor item [Unit]	Description
PUSH SW [On/Off]	The switch status input from push-button ignition switch
ENGINE STATE [Stop/Stall/Crank/Run]	The engine status received from ECM with CAN communication
VEH SPEED 1 [km/h]	The value of the vehicle speed received from combination meter with CAN communication
KEY SW-SLOT [On/Off]	Key switch status input from key slot

DIAGNOSIS SYSTEM (BCM)

< SYSTEM DESCRIPTION >

Monitor item [Unit]	Description	
TURN SIGNAL R [On/Off]	Each switch status that BCM detects from the combination switch reading function	A
TURN SIGNAL L [On/Off]		B
TAIL LAMP SW [On/Off]		C
HI BEAM SW [On/Off]		D
HEAD LAMP SW1 [On/Off]		E
HEAD LAMP SW2 [On/Off]		F
PASSING SW [On/Off]		G
AUTO LIGHT SW [On/Off]		H
FR FOG SW [On/Off]		I
RR FOG SW [On/Off]	NOTE: The item is indicated, but not monitored.	J
DOOR SW-DR [On/Off]	The switch status input from front door switch (driver side)	K
DOOR SW-AS [On/Off]	The switch status input from front door switch (passenger side)	L
DOOR SW-RR [On/Off]	The switch status input from rear door switch RH	
DOOR SW-RL [On/Off]	The switch status input from rear door switch LH	
DOOR SW-BK [On/Off]	NOTE: The item is indicated, but not monitored.	
OPTICAL SENSOR [V]	The value of exterior brightness voltage input from the optical sensor	

ACTIVE TEST

Test item	Operation	Description	
TAIL LAMP	On	Transmits the position light request signal to IPDM E/R with CAN communication to turn the tail lamp ON.	BCS
	Off	Stops the position light request signal transmission.	
HEAD LAMP	Hi	Transmits the high beam request signal with CAN communication to turn the headlamp (HI).	N
	Low	Transmits the low beam request signal with CAN communication to turn the headlamp (LO).	O
	Off	Stops the high & low beam request signal transmission.	
FR FOG LAMP	On	Transmits the front fog light request signal to IPDM E/R with CAN communication to turn the front fog lamp ON.	P
	Off	Stops the front fog light request signal transmission.	
RR FOG LAMP	On	NOTE:	
	Off	The item is indicated, but cannot be tested.	
DAYTIME RUNNING LIGHT	On	NOTE:	
	Off	The item is indicated, but cannot be tested.	

DIAGNOSIS SYSTEM (BCM)

< SYSTEM DESCRIPTION >

Test item	Operation	Description
CORNERING LAMP	RH	NOTE: The item is indicated, but cannot be tested.
	LH	
	Off	
ILL DIM SIGNAL	On	NOTE: The item is indicated, but cannot be tested.
	Off	

WIPER

WIPER : CONSULT Function (BCM - WIPER)

INFOID:000000010074042

WORK SUPPORT

Service item	Setting item	Description
WIPER SPEED SETTING	On	With vehicle speed (Front wiper intermittent time linked with the vehicle speed and wiper intermittent dial position)
	Off*	Without vehicle speed (Front wiper intermittent time linked with the wiper intermittent dial position)

*:Factory setting

NOTE:

Work support item is not indicated when the vehicle with rain sensor.

DATA MONITOR

NOTE:

The following table includes information (items) inapplicable to this vehicle. For information (items) applicable to this vehicle, refer to CONSULT display items.

Monitor Item [Unit]	Description
PUSH SW [Off/On]	The switch status input from push-button ignition switch.
VEHICLE SPEED 1 [km/h]	The value of the vehicle speed signal received from combination meter with CAN communication.
FR WIPER HI [Off/On]	Each switch status that BCM judges from the combination switch reading function.
FR WIPER LOW [Off/On]	
FR WASHER SW [Off/On]	
FR WIPER INT [Off/On]	
FR WIPER STOP [Off/On]	Front wiper motor (stop position) status received from IPDM E/R with CAN communication.
INT VOLUME [1 - 7]	Each switch status that BCM judges from the combination switch reading function.
RR WIPER ON [Off/On]	Each switch status that BCM judges from the combination switch reading function.
RR WIPER INT [Off/On]	
RR WASHER SW [Off/On]	
RR WIPER STOP [Off/On]	

ACTIVE TEST

DIAGNOSIS SYSTEM (BCM)

< SYSTEM DESCRIPTION >

Test item	Operation	Description
FR WIPER	Hi	Transmits the front wiper request signal (HI) to IPDM E/R with CAN communication to operate the front wiper HI operation.
	Lo	Transmits the front wiper request signal (LO) to IPDM E/R with CAN communication to operate the front wiper LO operation.
	INT	Transmits the front wiper request signal (INT) to IPDM E/R with CAN communication to operate the front wiper INT operation.
	Off	Stops transmitting the front wiper request signal to stop the front wiper operation.
RR WIPER	On	Outputs the voltage to operate the rear wiper motor.
	Off	Stops the voltage to stop.

FLASHER

FLASHER : CONSULT Function (BCM - FLASHER)

INFOID:000000010074037

WORK SUPPORT

Service item	Setting item	Setting
HAZARD ANSWER BACK	Lock Only*	With locking only
	Unlk Only	With unlocking only
	Lock/Unlk	With locking/unlocking
	Off	Without the function

Sets the hazard warning lamp answer back function when the door is lock/unlock with the request switch or the key fob.

*: Factory setting

DATA MONITOR

NOTE:

The following table includes information (items) inapplicable to this vehicle. For information (items) applicable to this vehicle, refer to CONSULT display items.

Monitor item [Unit]	Description
REQ SW-DR [On/Off]	The switch status input from the request switch (driver side)
REQ SW-AS [On/Off]	The switch status input from the request switch (passenger side)
PUSH SW [On/Off]	The switch status input from the push-button ignition switch
TURN SIGNAL R [On/Off]	Each switch status that BCM detects from the combination switch reading function
TURN SIGNAL L [On/Off]	
HAZARD SW [On/Off]	The switch status input from the hazard switch
RKE-LOCK [On/Off]	Lock signal status received from the remote keyless entry receiver
RKE-UNLOCK [On/Off]	Unlock signal status received from the remote keyless entry receiver
RKE-PANIC [On/Off]	Panic alarm signal status received from the remote keyless entry receiver

ACTIVE TEST

A
B
C
D
E
F
G
H
I
J
K
L
N
O
P

BCS

DIAGNOSIS SYSTEM (BCM)

< SYSTEM DESCRIPTION >

Test item	Operation	Description
FLASHER	RH	Outputs the voltage to blink the right side turn signal lamps.
	LH	Outputs the voltage to blink the left side turn signal lamps.
	Off	Stops the voltage to turn the turn signal lamps OFF.

FLASHER : CONSULT Function (BCM - FLASHER)

INFOID:000000010074038

WORK SUPPORT

Service item	Setting item	Setting	
HAZARD ANSWER BACK	Lock Only*	With locking only	Sets the hazard warning lamp answer back function when the door is lock/unlock with the request switch or the key fob.
	Unlk Only	With unlocking only	
	Lock/Unlk	With locking/unlocking	
	Off	Without the function	

*: Factory setting

DATA MONITOR

NOTE:

The following table includes information (items) inapplicable to this vehicle. For information (items) applicable to this vehicle, refer to CONSULT display items.

Monitor item [Unit]	Description
REQ SW-DR [On/Off]	The switch status input from the request switch (driver side)
REQ SW-AS [On/Off]	The switch status input from the request switch (passenger side)
PUSH SW [On/Off]	The switch status input from the push-button ignition switch
TURN SIGNAL R [On/Off]	Each switch status that BCM detects from the combination switch reading function
TURN SIGNAL L [On/Off]	
HAZARD SW [On/Off]	The switch status input from the hazard switch
RKE-LOCK [On/Off]	Lock signal status received from the remote keyless entry receiver
RKE-UNLOCK [On/Off]	Unlock signal status received from the remote keyless entry receiver
RKE-PANIC [On/Off]	Panic alarm signal status received from the remote keyless entry receiver

ACTIVE TEST

Test item	Operation	Description
FLASHER	RH	Outputs the voltage to blink the right side turn signal lamps.
	LH	Outputs the voltage to blink the left side turn signal lamps.
	Off	Stops the voltage to turn the turn signal lamps OFF.

INTELLIGENT KEY

INTELLIGENT KEY : CONSULT Function (BCM - INTELLIGENT KEY)

INFOID:000000010074030

BCM CONSULT FUNCTION

DIAGNOSIS SYSTEM (BCM)

< SYSTEM DESCRIPTION >

CONSULT performs the following functions via CAN communication with BCM.

Diagnosis mode	Function Description
WORK SUPPORT	Changes the setting for each system function.
SELF-DIAG RESULTS	Displays the diagnosis results judged by BCM.
DATA MONITOR	The BCM input/output signals are displayed.
ACTIVE TEST	The signals used to activate each device are forcibly supplied from BCM.

WORK SUPPORT

Monitor item	Description
REMO CONT ID CONFIR	It can be checked whether Intelligent Key ID code is registered or not in this mode.
AUTO LOCK SET	Auto door lock time can be changed in this mode. <ul style="list-style-type: none"> • MODE 1: 1 minute • MODE 2: 5 minutes • MODE 3: 30 seconds • MODE 4: 2 minutes
LOCK/UNLOCK BY I-KEY	Door lock/unlock function by door request switch (driver side, passenger side and back door) mode can be changed to operate (ON) or not operate (OFF) in this mode.
ENGINE START BY I-KEY	Engine start function mode can be changed to operate (ON) or not operate (OFF) with this mode.
TRUNK/GLASS HATCH OPEN	Buzzer reminder function mode by back door request switch can be changed to operate (ON) or not operate (OFF) with this mode.
PANIC ALARM SET	Panic alarm button pressing time on Intelligent Key remote control button can be selected from the following with this mode. <ul style="list-style-type: none"> • MODE 1: 0.5 sec. • MODE 2: Non-operation • MODE 3: 1.5 sec.
PW DOWN SET	Unlock button pressing time on Intelligent Key button can be selected from the following with this mode. <ul style="list-style-type: none"> • MODE 1: 3 sec. • MODE 2: Non-operation • MODE 3: 5 sec.
TRUNK OPEN DELAY	NOTE: This item is displayed, but cannot be supported.
LO- BATT OF KEY FOB WARN	Intelligent Key low battery warning mode can be changed to operate (ON) or not operate (OFF) with this mode.
ANTI KEY LOCK IN FUNCTI	Key reminder function mode can be changed to operate (ON) or not operate (OFF) with this mode.
HAZARD ANSWER BACK	Hazard reminder function mode can be selected from the following with this mode. <ul style="list-style-type: none"> • LOCK ONLY: Door lock operation only • UNLOCK ONLY: Door unlock operation only • LOCK/UNLOCK: Lock/unlock operation • OFF: Non-operation
ANS BACK I-KEY LOCK	Buzzer reminder function (lock operation) mode by door request switch (driver side and passenger side) can be selected from the following with this mode. <ul style="list-style-type: none"> • Horn chirp: Sound horn • Buzzer: Sound Intelligent Key warning buzzer • OFF: Non-operation
ANS BACK I-KEY UNLOCK	Buzzer reminder function (unlock operation) mode by door request switch can be changed to operate (ON) or not operate (OFF) with this mode.
SHORT CRANKING OUTPUT	Starter motor can operate during the times below. <ul style="list-style-type: none"> • 70 msec • 100 msec • 200 msec
INSIDE ANT DIAGNOSIS	This function allows inside key antenna self-diagnosis.
HORN WITH KEYLESS LOCK	Horn reminder function mode by Intelligent Key button can be changed to operate (ON) or not operate (OFF) with this mode.

DIAGNOSIS SYSTEM (BCM)

< SYSTEM DESCRIPTION >

SELF-DIAG RESULT

Refer to [BCS-91. "DTC Index"](#).

DATA MONITOR

NOTE:

The following table includes information (items) inapplicable to this vehicle. For information (items) applicable to this vehicle, refer to CONSULT display items.

Monitor Item	Condition
REQ SW -DR	Indicates [ON/OFF] condition of door request switch (driver side).
REQ SW -AS	Indicates [ON/OFF] condition of door request switch (passenger side).
REQ SW -RR	NOTE: This item is displayed, but cannot be monitored.
REQ SW -RL	NOTE: This item is displayed, but cannot be monitored.
REQ SW -BD/TR	Indicates [ON/OFF] condition of back door request switch.
PUSH SW	Indicates [ON/OFF] condition of push-button ignition switch.
IGN RLY2 -F/B	Indicates [ON/OFF] condition of ignition relay 2.
ACC RLY-FB	NOTE: This item is displayed, but cannot be monitored.
CLUCH SW	NOTE: This item is displayed, but cannot be monitored.
BRAKE SW 1	Indicates [ON/OFF]* condition of brake switch power supply.
BRAKE SW 2	Indicates [ON/OFF] condition of brake switch.
DETE/CANCL SW	Indicates [ON/OFF] condition of P position.
SFT PN/N SW	Indicates [ON/OFF] condition of P or N position.
S/L -LOCK	Indicates [ON/OFF] condition of steering lock unit (LOCK). NOTE: For models without steering lock unit this item is not displayed.
S/L -UNLOCK	Indicates [ON/OFF] condition of steering lock unit (UNLOCK). NOTE: For models without steering lock unit this item is not displayed.
S/L RELAY -F/B	Indicates [ON/OFF] condition of ignition switch. NOTE: For models without steering lock unit this item is not displayed.
UNLK SEN -DR	Indicates [ON/OFF] condition of driver door UNLOCK status.
PUSH SW -IPDM	Indicates [ON/OFF] condition of push-button ignition switch.
IGN RLY1 -F/B	Indicates [ON/OFF] condition of ignition relay 1.
DETE SW -IPDM	Indicates [ON/OFF] condition of P position.
SFT PN -IPDM	Indicates [ON/OFF] condition of P or N position.
SFT P -MET	Indicates [ON/OFF] condition of P position.
SFT N -MET	Indicates [ON/OFF] condition of N position.
ENGINE STATE	Indicates [STOP/START/CRANK/RUN] condition of engine states.
S/L LOCK-IPDM	Indicates [ON/OFF] condition of steering lock unit (LOCK). NOTE: For models without steering lock unit this item is not displayed.
S/L UNLK-IPDM	Indicates [ON/OFF] condition of steering lock unit (UNLOCK). NOTE: For models without steering lock unit this item is not displayed.
S/L RELAY-REQ	Indicates [ON/OFF] condition of steering lock relay. NOTE: For models without steering lock unit this item is not displayed.
VEH SPEED 1	Display the vehicle speed signal received from combination meter by numerical value [Km/h].

DIAGNOSIS SYSTEM (BCM)

< SYSTEM DESCRIPTION >

Monitor Item	Condition	
VEH SPEED 2	Display the vehicle speed signal received from ABS or VDC or CVT by numerical value [Km/h].	A
DOOR STAT-DR	Indicates [LOCK/READY/UNLOCK] condition of driver side door status.	
DOOR STAT-AS	Indicates [LOCK/READY/UNLOCK] condition of passenger side door status.	B
ID OK FLAG	Indicates [SET/RESET] condition of key ID.	
PRMT ENG STRT	Indicates [SET/RESET] condition of engine start possibility.	
PRMT RKE STRT	NOTE: This item is displayed, but cannot be monitored.	C
KEY SW -SLOT	Indicates [ON/OFF] condition of key slot.	
TRNK/HAT MNTR	NOTE: This item is displayed, but cannot be monitored.	D
RKE-LOCK	Indicates [ON/OFF] condition of LOCK signal from Intelligent Key.	
RKE-UNLOCK	Indicates [ON/OFF] condition of UNLOCK signal from Intelligent Key.	E
RKE-TR/BD	NOTE: This item is displayed, but cannot be monitored.	
RKE-PANIC	Indicates [ON/OFF] condition of PANIC button of Intelligent Key.	F
RKE-P/W OPEN	Indicates [ON/OFF] condition of P/W DOWN signal from Intelligent Key.	
RKE-MODE CHG	Indicates [ON/OFF] condition of MODE CHANGE signal from Intelligent Key.	G
RKE OPE COUN1	When remote keyless entry receiver receives the signal transmitted while operating on Intelligent Key, the numerical value start changing.	
RKE OPE COUN2	NOTE: This item is displayed, but cannot be monitored.	H

*: OFF is displayed when brake pedal is depressed while brake switch power supply is OFF.

ACTIVE TEST

Test item	Description	
BATTERY SAVER	This test is able to check interior room lamp operation. The interior room lamp will be activated after "ON" on CONSULT screen is touched.	J
PW REMOTO DOWN SET	This test is able to check power window down operation. The power window down will be activated after "ON" on CONSULT screen is touched.	K
INSIDE BUZZER	This test is able to check warning chime in combination meter operation. <ul style="list-style-type: none"> Take away warning chime sounds when "TAKE OUT" on CONSULT screen is touched. Key warning chime sounds when "KEY WARN" on CONSULT screen is touched. P position warning chime sounds when "P RNG WARN" on CONSULT screen is touched. ACC warning chime sounds when "ACC WARN" on CONSULT screen is touched. 	L
OUTSIDE BUZZER	This test is able to check Intelligent Key warning buzzer operation. The Intelligent Key warning buzzer will be activated after "ON" on CONSULT screen is touched.	BCS
INDICATOR	This test is able to check warning lamp operation. <ul style="list-style-type: none"> "KEY" Warning lamp illuminates when "KEY ON" on CONSULT screen is touched. "KEY" Warning lamp flashes when "KEY IND" on CONSULT screen is touched. 	N
INT LAMP	This test is able to check interior room lamp operation. The interior room lamp will be activated after "ON" on CONSULT screen is touched.	O

DIAGNOSIS SYSTEM (BCM)

< SYSTEM DESCRIPTION >

Test item	Description
LCD	<p>This test is able to check meter display information</p> <ul style="list-style-type: none"> • Engine start information displays when “BP N” on CONSULT screen is touched. • Engine start information displays when “BP I” on CONSULT screen is touched. • Key ID warning displays when “ID NG” on CONSULT screen is touched. • Steering lock information displays when “ROTAT” on CONSULT screen is touched. <p>NOTE: For models without steering lock unit, “ROTAT” is displayed, but cannot be tested.</p> <ul style="list-style-type: none"> • P position warning displays when “SFT P” on CONSULT screen is touched. • Intelligent Key insert information displays when “INSRT” on CONSULT screen is touched. • Intelligent Key low battery warning displays when “BATT” on CONSULT screen is touched. • Take away through window warning displays when “NO KY” on CONSULT screen is touched. • Take away warning display when “OUTKEY” on CONSULT screen is touched. • OFF position warning display when “LK WN” on CONSULT screen is touched.
TRUNK/GLASS HATCH	<p>This test is able to check back door opener actuator open operation. This actuator opens when “ON” on CONSULT screen is touched.</p>
FLASHER	<p>This test is able to check hazard warning lamp operation. The hazard warning lamps will be activated after “ON” on CONSULT screen is touched.</p>
HORN	<p>This test is able to check horn operation. The horn will be activated after “ON” on CONSULT screen is touched.</p>
IGN CONT2	<p>This test is able to check ignition relay operation. The ignition relay will be activated after “ON” on CONSULT screen is touched.</p>
P RANGE	<p>This test is able to check CVT shift selector power supply CVT shift selector power is supplied when “ON” on CONSULT screen is touched.</p>
ENGINE SW ILLUMI	<p>This test is able to check push-ignition switch illumination operation. Push-ignition switch illumination illuminates when “ON” on CONSULT screen is touched.</p>
LOCK INDICATOR	<p>NOTE: This item is displayed, but cannot be tested.</p>
ACC INDICATOR	<p>This test is able to check indicator in push-ignition switch operation. Indicator in push-button ignition switch illuminates when “ON” on CONSULT screen is touched.</p>
IGNITION ON IND	<p>This test is able to check indicator in push-ignition switch operation. Indicator in push-button ignition switch illuminates when “ON” on CONSULT screen is touched.</p>
KEY SLOT ILLUMI	<p>This test is able to check key slot illumination operation. Key slot illumination flash when “ON” on CONSULT screen is touched.</p>
AUTOMATIC BACK DOOR	<p>NOTE: This item is displayed, but cannot be tested.</p>
AUTOMATIC SLIDING DOOR	<p>NOTE: This item is displayed, but cannot be tested.</p>

COMB SW

COMB SW : CONSULT Function (BCM - COMB SW)

INFOID:000000009722450

DATA MONITOR

NOTE:

The following table includes information (items) inapplicable to this vehicle. For information (items) applicable to this vehicle, refer to CONSULT display items.

Monitor item [UNIT]	Description
FR WIPER HI [Off/On]	Displays the status of the FR WIPER HI switch in combination switch judged by BCM with the combination switch reading function.
FR WIPER LOW [Off/On]	Displays the status of the FR WIPER LOW switch in combination switch judged by BCM with the combination switch reading function.
FR WASHER SW [Off/On]	Displays the status of the FR WASHER switch in combination switch judged by BCM with the combination switch reading function.
FR WIPER INT [Off/On]	Displays the status of the FR WIPER INT switch in combination switch judged by BCM with the combination switch reading function.

DIAGNOSIS SYSTEM (BCM)

< SYSTEM DESCRIPTION >

Monitor item [UNIT]	Description
FR WIPER STOP [Off/On]	Displays the status of the front wiper stop position signal received from IPDM E/R via CAN communication.
INT VOLUME [1 - 7]	Displays the status of wiper intermittent dial position judged by BCM with the combination switch reading function.
RR WIPER ON [Off/On]	Displays the status of the RR WIPER ON switch in combination switch judged by BCM with the combination switch reading function.
RR WIPER INT [Off/On]	Displays the status of the RR WIPER INT switch in combination switch judged by BCM with the combination switch reading function.
RR WASHER SW [Off/On]	Displays the status of the RR WASHER switch in combination switch judged by BCM with the combination switch reading function.
RR WIPER STOP [Off/On]	Displays the status of the rear wiper stop position signal received from rear wiper motor.
TURN SIGNAL R [Off/On]	Displays the status of the TURN RH switch in combination switch judged by BCM with the combination switch reading function.
TURN SIGNAL L [Off/On]	Displays the status of the TURN LH switch in combination switch judged by BCM with the combination switch reading function.
TAIL LAMP SW [Off/On]	Displays the status of the TAIL LAMP switch in combination switch judged by BCM with the combination switch reading function.
HI BEAM SW [Off/On]	Displays the status of the HI BEAM switch in combination switch judged by BCM with the combination switch reading function.
HEAD LAMP SW 1 [Off/On]	Displays the status of the HEADLAMP 1 switch in combination switch judged by BCM with the combination switch reading function.
HEAD LAMP SW 2 [Off/On]	Displays the status of the HEADLAMP 2 switch in combination switch judged by BCM with the combination switch reading function.
PASSING SW [Off/On]	Displays the status of the PASSING switch in combination switch judged by BCM with the combination switch reading function.
AUTO LIGHT SW [Off/On]	Displays the status of the AUTO LIGHT switch in combination switch judged by BCM with the combination switch reading function.
FR FOG SW [Off/On]	Displays the status of the FR FOG switch in combination switch judged by BCM with the combination switch reading function.
RR FOG SW [Off/On]	NOTE: The item is indicated, but not monitored.

BCM

BCM : CONSULT Function (BCM - BCM)

INFOID:000000009722451

WORK SUPPORT

Item	Description
RESET SETTING VALUE	Return a value set with Work Support of each system to a default value in factory shipment.

IMMU

IMMU : CONSULT Function (BCM - IMMU)

INFOID:0000000010074033

APPLICATION ITEM

CONSULT performs the following functions via CAN communication with BCM.

Diagnosis mode	Function Description
DATA MONITOR	The BCM input/output signals are displayed.
ACTIVE TEST	The signals used to activate each device are forcibly supplied from BCM.

DATA MONITOR

NOTE:

DIAGNOSIS SYSTEM (BCM)

< SYSTEM DESCRIPTION >

The following table includes information (items) inapplicable to this vehicle. For information (items) applicable to this vehicle, refer to CONSULT display items.

Monitor item	Content
CONFIRM ID ALL	Indicates [YET] at all time. Switch to [DONE] when a registered Intelligent Key is inserted into the key slot.
CONFIRM ID4	
CONFIRM ID3	
CONFIRM ID2	
CONFIRM ID1	
TP 4	Indicates the number of ID which has been registered.
TP 3	
TP 2	
TP 1	
PUSH SW	Indicates [ON/OFF] condition of push-button ignition switch.
KEY SW -SLOT	Indicates [ON/OFF] condition of key slot.

ACTIVE TEST

Test item	Description
THEFT IND	This test is able to check security indicator lamp operation. The lamp will be turned on when "ON" on CONSULT screen touched.

BATTERY SAVER

BATTERY SAVER : CONSULT Function (BCM - BATTERY SAVER)

INFOID:000000010074040

WORK SUPPORT

Service item	Setting item	Setting
BATTERY SAVER SET	On*	With the exterior lamp battery saver function
	Off	Without the exterior lamp battery saver function
ROOM LAMP BAT SAV SET	On*	With the interior room lamp battery saver function
	Off	Without the interior room lamp battery saver function
ROOM LAMP TIMER SET	MODE 1	30 min.
	MODE 2	60 min.
	MODE 3*	15 min.
		Sets the interior room lamp battery saver timer operating time.

*: Factory setting

DATA MONITOR

NOTE:

The following table includes information (items) inapplicable to this vehicle. For information (items) applicable to this vehicle, refer to CONSULT display items.

Monitor item [Unit]	Description
REQ SW-DR [On/Off]	The switch status input from request switch (driver side)
REQ SW-AS [On/Off]	The switch status input from front request switch (passenger side)
REQ SW-RR [On/Off]	NOTE: The item is indicated, but not monitored.
REQ SW-RL [On/Off]	

DIAGNOSIS SYSTEM (BCM)

< SYSTEM DESCRIPTION >

Monitor item [Unit]	Description
PUSH SW [On/Off]	The switch status input from push-button ignition switch
KEY SW-SLOT [On/Off]	Key switch status input from key slot
UNLK SEN-DR [On/Off]	Driver door unlock status input from unlock sensor
DOOR SW-DR [On/Off]	The switch status input from front door switch (driver side)
DOOR SW-AS [On/Off]	The switch status input from front door switch (passenger side)
DOOR SW-RR [On/Off]	The switch status input from rear door switch RH
DOOR SW-RL [On/Off]	The switch status input from rear door switch LH
DOOR SW-BK [On/Off]	NOTE: The item is indicated, but not monitored.
CDL LOCK SW [On/Off]	Lock switch status received from door lock/unlock switch by power window switch serial link
CDL UNLOCK SW [On/Off]	Unlock switch status received from door lock/unlock switch by power window switch serial link
KEY CYL LK-SW [On/Off]	Lock switch status received from key cylinder lock/unlock switch by power window switch serial link
KEY CYL UN-SW [On/Off]	Unlock switch status received from key cylinder lock/unlock switch by power window switch serial link
BACK DOOR SW [On/Off]	The switch status input from back door switch
RKE-LOCK [On/Off]	Lock signal status received from remote keyless entry receiver
RKE-UNLOCK [On/Off]	Unlock signal status received from remote keyless entry receiver

ACTIVE TEST

Test item	Operation	Description
BATTERY SAVER	Off	Cuts the interior room lamp power supply to turn interior room lamp OFF.
	On	Outputs the interior room lamp power supply to turn interior room lamp ON.*

*: Each lamp switch is in ON position.

TRUNK

TRUNK : CONSULT Function (BCM - TRUNK)

INFOID:000000010074031

BCM CONSULT FUNCTION

CONSULT performs the following functions via CAN communication with BCM.

Diagnosis mode	Function Description
DATA MONITOR	The BCM input/output signals are displayed.
ACTIVE TEST	The signals used to activate each device are forcibly supplied from BCM.

DATA MONITOR

NOTE:

The following table includes information (items) inapplicable to this vehicle. For information (items) applicable to this vehicle, refer to CONSULT display items.

DIAGNOSIS SYSTEM (BCM)

< SYSTEM DESCRIPTION >

Monitor Item	Contents
PUSH SW	Indicates [ON/OFF] condition of push-button ignition switch.
UNLK SEN -DR	NOTE: This item is displayed, but cannot be monitored.
VEH SPEED 1	Indicates [Km/h] condition of vehicle speed signal from combination meter.
KEY CYL SW-TR	NOTE: This item is displayed, but cannot be monitored.
TR CANCEL SW	NOTE: This item is displayed, but cannot be monitored.
TR/BD OPEN SW	Indicates [ON/OFF] condition of back door opener switch.
TRNK/HAT MNTR	NOTE: This item is displayed, but cannot be monitored.
RKE-TR/BD*	NOTE: This item is displayed, but cannot be monitored.

*: With back door opener system

ACTIVE TEST

Test item	Description
TRUNK/GLASS HATCH	This test is able to check back door opener actuator open operation. This actuator opens when ""

THEFT ALM

THEFT ALM : CONSULT Function (BCM - THEFT)

INFOID:000000010074032

APPLICATION ITEM

CONSULT performs the following functions via CAN communication with BCM.

Diagnosis mode	Function Description
WORK SUPPORT	Changes the setting for each system function.
DATA MONITOR	The BCM input/output signals are displayed.
ACTIVE TEST	The signals used to activate each device are forcibly supplied from BCM.

DATA MONITOR

NOTE:

The following table includes information (items) inapplicable to this vehicle. For information (items) applicable to this vehicle, refer to CONSULT display items.

Monitored Item	Description
REQ SW -DR	Indicates [ON/OFF] condition of door request switch (driver side).
REQ SW -AS	Indicates [ON/OFF] condition of door request switch (passenger side).
REQ SW -RR	NOTE: This is displayed even when it is not equipped.
REQ SW -RL	NOTE: This is displayed even when it is not equipped.
REQ SW -BD/TR	Indicates [ON/OFF] condition of back door request switch.
PUSH SW	Indicates [ON/OFF] condition of push-button ignition switch
UNLK SEN -DR	Indicates [ON/OFF] condition of driver door UNLOCK status.
KEY SW -SLOT	Indicates [ON/OFF] condition of key slot.
DOOR SW-DR	Indicates [ON/OFF] condition of front door switch LH.
DOOR SW-AS	Indicates [ON/OFF] condition of front door switch RH.

DIAGNOSIS SYSTEM (BCM)

< SYSTEM DESCRIPTION >

Monitored Item	Description
DOOR SW-RR	Indicates [ON/OFF] condition of rear door switch RH.
DOOR SW-RL	Indicates [ON/OFF] condition of rear door switch LH.
DOOR SW-BK	Indicates [ON/OFF] condition of back door switch.
CDL LOCK SW	Indicates [ON/OFF] condition of lock signal from door lock/unlock switch LH and RH.
CDL UNLOCK SW	Indicates [ON/OFF] condition of unlock signal from door lock/unlock switch LH and RH.
KEY CYL LK-SW	Indicates [ON/OFF] condition of lock signal from front door key cylinder switch.
KEY CYL UN-SW	Indicates [ON/OFF] condition of unlock signal from front door key cylinder switch.
KEY CYL SW-TR	NOTE: This is displayed even when it is not equipped.
TR/BD OPEN SW	Indicates [ON/OFF] condition of back door opener switch.
TRNK/HAT MNTR	NOTE: This is displayed even when it is not equipped.
RKE-LOCK	Indicates [ON/OFF] condition of LOCK signal from Intelligent Key.
RKE-UNLOCK	Indicates [ON/OFF] condition of UNLOCK signal from Intelligent Key.
RKE-TR/BD	NOTE: This is displayed even when it is not equipped.

WORK SUPPORT

Test Item	Description
SECURITY ALARM SET	This mode is able to confirm and change security alarm ON-OFF setting.
THEFT ALM TRG	The switch which triggered vehicle security alarm is recorded. This mode is able to confirm and erase the record of vehicle security alarm. The trigger data can be erased by touching "CLEAR" on CONSULT screen.

ACTIVE TEST

Test Item	Description
THEFT IND	This test is able to check security indicator lamp operation. The lamp will be turned on when "ON" on CONSULT screen is touched.
VEHICLE SECURITY HORN	This test is able to check vehicle security horn operation. The horns will be activated for 0.5 seconds after "ON" on CONSULT screen is touched.
HEADLAMP(HI)	This test is able to check vehicle security lamp operation. The headlamps will be activated for 0.5 seconds after "ON" on CONSULT screen is touched.
FLASHER	This test is able to check vehicle security hazard lamp operation. The hazard lamps will be activated after "ON" on CONSULT screen is touched.

RETAINED PWR

RETAINED PWR : CONSULT Function (BCM - RETAINED PWR)

INFOID:0000000010074034

Data monitor

NOTE:

The following table includes information (items) inapplicable to this vehicle. For information (items) applicable to this vehicle, refer to CONSULT display items.

Monitor Item	Description
DOOR SW-DR	Indicates [ON/OFF] condition of driver side door switch.
DOOR SW-AS	Indicates [ON/OFF] condition of passenger side door switch.

SIGNAL BUFFER

DIAGNOSIS SYSTEM (BCM)

< SYSTEM DESCRIPTION >

SIGNAL BUFFER : CONSULT Function (BCM - SIGNAL BUFFER)

INFOID:00000000972457

DATA MONITOR

NOTE:

The following table includes information (items) inapplicable to this vehicle. For information (items) applicable to this vehicle, refer to CONSULT display items.

Monitor item [UNIT]	Description
PUSH SW [Off/On]	Displays the status of the push-button ignition switch (push switch) judged by BCM.

ACTIVE TEST

Test item	Operation	Description
OIL PRESSURE SW	Off	OFF
	On	BCM transmits the oil pressure switch signal to the combination meter via CAN communication, which illuminates the oil pressure warning lamp in the combination meter.

AIR PRESSURE MONITOR

AIR PRESSURE MONITOR : CONSULT Function (BCM - AIR PRESSURE MONITOR)

INFOID:0000000010074028

APPLICATION ITEMS

CONSULT performs the following functions via CAN communication with BCM.

Diagnosis mode	Function Description
Self Diagnostic Result	Displays the diagnosis results judged by BCM.
Data Monitor	The BCM input/output signals are displayed.
Active Test	The signals used to activate each device are forcibly supplied from BCM.
Work Support	Components can be quickly and accurately adjusted.

SELF DIAGNOSTIC RESULT

Refer to [BCS-91, "DTC Index"](#).

When "CRNT" is displayed on self-diagnosis result,

- The system is presently malfunctioning.

When "PAST" is displayed on self-diagnosis result,

- System malfunction in the past is detected, but the system is presently normal.

DATA MONITOR MODE

Screen of data monitor mode is displayed.

NOTE:

- When malfunction is detected, CONSULT perform REAL-TIME DIAGNOSIS. Also, any malfunction detected while in this mode will be displayed at real time.
- The following table includes information(items)inapplicable to this vehicle. For information(items)applicable to this vehicle, refer to CONSULT display items.

Monitor item (Unit)	Remark
AIR PRESS FL (kPa/kg/cm ² /Psi)	Tire pressure
AIR PRESS FR (kPa/kg/cm ² /Psi)	
AIR PRESS RR (kPa/kg/cm ² /Psi)	
AIR PRESS RL (kPa/kg/cm ² /Psi)	

DIAGNOSIS SYSTEM (BCM)

< SYSTEM DESCRIPTION >

Monitor item (Unit)	Remark
ID REGST FL1 (Green/Red)	Registration ID
ID REGST FR1 (Green/Red)	
ID REGST RR1 (Green/Red)	
ID REGST RL1 (Green/Red)	
WARNING LAMP (On/Off)	Low tire pressure warning lamp
BUZZER (On/Off)	NOTE: This item is displayed, but cannot be use this item.

NOTE:

Before performing the self-diagnosis, be sure to register the ID, or erase the actual malfunction location may be different from that displayed on CONSULT.

ACTIVE TEST MODE

NOTE:

Before performing the self-diagnosis, be sure to register the ID, or erase the actual malfunction may be different from that displayed on CONSULT.

TEST ITEM LIST

Test item	Content
WARNING LAMP	This test is able to check to check that the low tire pressure warning lamp turns on.
ID REGIST WARNING	This test is able to check to check that the low tire pressure warning lamp turns on.
FLASHER	This test is able to check to check that each turn signal lamp turns on.
HORN	This test is able to check to check that the horn sounds.

WORK SUPPORT MODE

Item	Description
ID READ	Registered tire pressure sensor ID can be displayed.
ID REGIST	Tire pressure sensor ID can be registered.

A
B
C
D
E
F
G
H
I
J
K
L
N
O
P

BCS

U1000 CAN COMM

< DTC/CIRCUIT DIAGNOSIS >

DTC/CIRCUIT DIAGNOSIS

U1000 CAN COMM

Description

INFOID:000000009722459

CAN (Controller Area Network) is a serial communication line for real time applications. It is an on-vehicle multiplex communication line with high data communication speed and excellent error detection ability. Modern vehicle is equipped with many electronic control unit, and each control unit shares information and links with other control units during operation (not independent). In CAN communication, control units are connected with 2 communication lines (CAN H-line, CAN L-line) allowing a high rate of information transmission with less wiring. Each control unit transmits/receives data but selectively reads required data only.
CAN Communication Signal Chart. Refer to [LAN-29, "CAN Communication Signal Chart"](#).

DTC Logic

INFOID:000000009722460

DTC DETECTION LOGIC

DTC	CONSULT display description	DTC Detection Condition	Possible cause
U1000	CAN COMM	When BCM cannot communicate CAN communication signal continuously for 2 seconds or more.	CAN communication system

Diagnosis Procedure

INFOID:000000009722461

1. PERFORM SELF DIAGNOSTIC

1. Turn ignition switch ON and wait for 2 seconds or more.
2. Check "Self Diagnostic Result".

Is DTC "U1000" displayed?

- YES >> Refer to [LAN-18, "Trouble Diagnosis Flow Chart"](#).
NO >> Refer to [GI-44, "Intermittent Incident"](#).

U1010 CONTROL UNIT (CAN)

< DTC/CIRCUIT DIAGNOSIS >

U1010 CONTROL UNIT (CAN)

DTC Logic

INFOID:000000009722462

DTC DETECTION LOGIC

DTC	CONSULT display de- scription	DTC Detection Condition	Possible cause
U1010	CONTROL UNIT(CAN)	BCM detected internal CAN communication circuit malfunction.	BCM

Diagnosis Procedure

INFOID:000000009722463

1.REPLACE BCM

When DTC "U1010" is detected, replace BCM.

>> Replace BCM. Refer to [BCS-98. "Exploded View"](#).

A
B
C
D
E
F
G
H
I
J
K
L

BCS

N
O
P

U0415 VEHICLE SPEED SIG

< DTC/CIRCUIT DIAGNOSIS >

U0415 VEHICLE SPEED SIG

Description

INFOID:000000009722464

U0415 is displayed if any unusual condition is present in the reception status of the vehicle speed signal from the ABS actuator and electric unit (control unit).

DTC Logic

INFOID:000000009722465

DTC DETECTION LOGIC

DTC	CONSULT display description	DTC Detection Condition	Probable cause
U0415	VEHICLE SPEED	When the vehicle speed signal received from the ABS actuator and electric unit (control unit) remains abnormal for 2 seconds or more.	<ul style="list-style-type: none">• ABS actuator and electric unit (control unit)• BCM

DTC CONFIRMATION PROCEDURE

1. DTC CONFIRMATION

1. Erase the DTC.
2. Turn ignition switch OFF.
3. Perform the "Self Diagnostic Result" of CONSULT, when passed 2 seconds or more after the ignition switch is turned ON.

Is any DTC detected?

- YES >> Refer to [BCS-44, "Diagnosis Procedure"](#).
NO >> INSPECTION END

Diagnosis Procedure

INFOID:000000009722466

1. ABS ACTUATOR AND ELECTRIC UNIT (CONTROL UNIT) SELF-DIAG RESULTS

Perform "Self-Diagnostic Result" of ABS actuator and electric unit (control unit) with CONSULT. Refer to [BRC-28, "CONSULT Function"](#).

Is any DTC detected?

- YES >> Repair or replace the malfunctioning part.
NO >> Replace BCM. Refer to [BCS-98, "Exploded View"](#).

B2562 LOW VOLTAGE

< DTC/CIRCUIT DIAGNOSIS >

B2562 LOW VOLTAGE

DTC Logic

INFOID:000000009722467

DTC DETECTION LOGIC

DTC	CONSULT display description	DTC Detection Condition	Possible cause
B2562	LOW VOLTAGE	When the power supply voltage to BCM remains less than 8.8 V for 120 seconds or more	Harness or connector (power supply circuit)

DTC CONFIRMATION PROCEDURE

1. DTC CONFIRMATION

1. Erase DTC.
2. Turn ignition switch OFF.
3. Perform the "Self Diagnostic Result" of CONSULT, when passed 120 seconds or more after the ignition switch is turned ON.

Is any DTC detected?

- YES >> Refer to [BCS-45, "Diagnosis Procedure"](#).
NO >> INSPECTION END

Diagnosis Procedure

INFOID:000000009722468

1. CHECK POWER SUPPLY CIRCUIT

Check BCM power supply circuit. Refer to [BCS-46, "Diagnosis Procedure"](#).

Is the circuit normal?

- YES >> Replace BCM. Refer to [BCS-98, "Exploded View"](#).
NO >> Repair the malfunctioning part.

A
B
C
D
E
F
G
H
I
J
K
L

BCS

N
O
P

POWER SUPPLY AND GROUND CIRCUIT

< DTC/CIRCUIT DIAGNOSIS >

POWER SUPPLY AND GROUND CIRCUIT

Diagnosis Procedure

INFOID:000000009722469

1. CHECK FUSE AND FUSIBLE LINK

Check that the following fuse and fusible link are not blown.

Signal name	Fuse and fusible link No.
Battery power supply	L
	10

Is the fuse fusing?

- YES >> Replace the blown fuse or fusible link after repairing the affected circuit if a fuse or fusible link is blown.
NO >> GO TO 2.

2. CHECK POWER SUPPLY CIRCUIT

1. Turn ignition switch OFF.
2. Disconnect BCM connectors.
3. Check voltage between BCM harness connector and ground.

Terminals		Voltage (Approx.)
(+)	(-)	
BCM		Ground Battery voltage
Connector	Terminal	
M118	1	
M119	11	

Is the measurement value normal?

- YES >> GO TO 3.
NO >> Repair harness or connector.

3. CHECK GROUND CIRCUIT

Check continuity between BCM harness connector and ground.

BCM		Ground	Continuity
Connector	Terminal		
M119	13		Existed

Does continuity exist?

- YES >> INSPECTION END
NO >> Repair harness or connector.

COMBINATION SWITCH INPUT CIRCUIT

< DTC/CIRCUIT DIAGNOSIS >

COMBINATION SWITCH INPUT CIRCUIT

Diagnosis Procedure

INFOID:000000009722470

1. CHECK INPUT 1 - 5 SYSTEM CIRCUIT FOR OPEN

1. Turn the ignition switch OFF.
2. Disconnect the BCM and combination switch connectors.
3. Check continuity between BCM harness connector and combination switch harness connector.

System	BCM		Combination switch		Continuity
	Connector	Terminal	Connector	Terminal	
INPUT 1	M122	107	M103	11	Existed
INPUT 2		109		9	
INPUT 3		88		7	
INPUT 4		108		10	
INPUT 5		87		13	

Does continuity exist?

YES >> GO TO 2.

NO >> Repair the harnesses or connectors.

2. CHECK INPUT 1 - 5 SYSTEM CIRCUIT FOR SHORT

Check for continuity between BCM harness connector and ground.

System	BCM		Ground	Continuity
	Connector	Terminal		
INPUT 1	M122	107	Ground	Not existed
INPUT 2		109		
INPUT 3		88		
INPUT 4		108		
INPUT 5		87		

Does continuity exist?

YES >> Repair the harnesses or connectors.

NO >> GO TO 3.

3. CHECK BCM OUTPUT VOLTAGE

1. Connect the BCM connector.
2. Check voltage between BCM harness connector and ground.

System	Terminals		Voltage (Approx.)
	(+)	(-)	
	BCM		
	Connector	Terminal	
INPUT 1	M122	107	Ground
INPUT 2		109	
INPUT 3		88	
INPUT 4		108	
INPUT 5		87	

Is the measurement value normal?

YES >> GO TO 4.

NO >> Replace BCM. Refer to [BCS-98. "Exploded View"](#).

A

B

C

D

E

F

G

H

I

J

K

L

BCS

N

O

P

COMBINATION SWITCH INPUT CIRCUIT

< DTC/CIRCUIT DIAGNOSIS >

4. CHECK BCM INPUT SIGNAL

1. Connect the combination switch connector.
2. Turn ON any switch in the system that is malfunctioning.
3. Check voltage between BCM harness connector and ground.

System	Terminals		Voltage (Approx.)
	(+)	(-)	
	BCM		
	Connector	Terminal	
INPUT 1	M122	107	Ground
INPUT 2		109	
INPUT 3		88	
INPUT 4		108	
INPUT 5		87	

Refer to [BCS-51](#), "Reference Value".

Is the measurement value normal when any of the switches is turned ON?

- YES >> Replace BCM. Refer to [BCS-98](#), "Exploded View".
NO >> Replace the combination switch.

COMBINATION SWITCH OUTPUT CIRCUIT

< DTC/CIRCUIT DIAGNOSIS >

COMBINATION SWITCH OUTPUT CIRCUIT

Diagnosis Procedure

INFOID:000000009722471

1. CHECK OUTPUT 1 - 5 SYSTEM CIRCUIT FOR OPEN

1. Turn the ignition switch OFF.
2. Disconnect the BCM and combination switch connectors.

NOTE:

BCM connector disconnects M123 only.

3. Check continuity between BCM harness connector and combination switch harness connector.

System	BCM		Combination switch		Continuity
	Connector	Terminal	Connector	Terminal	
OUTPUT 1	M123	143	M103	12	Existed
OUTPUT 2		144		14	
OUTPUT 3		145		5	
OUTPUT 4		146		2	
OUTPUT 5		142		8	

Does continuity exist?

YES >> GO TO 2.

NO >> Repair the harnesses or connectors.

2. CHECK OUTPUT 1 - 5 SYSTEM CIRCUIT FOR SHORT

Check for continuity between BCM harness connector and ground.

System	BCM		Ground	Continuity
	Connector	Terminal		
OUTPUT 1	M123	143	Ground	Not existed
OUTPUT 2		144		
OUTPUT 3		145		
OUTPUT 4		146		
OUTPUT 5		142		

Does continuity exist?

YES >> Repair the harnesses or connectors.

NO >> GO TO 3.

3. CHECK COMBINATION SWITCH INTERNAL CIRCUIT

1. Connect the combination switch connector.
2. Turn ON any switch in the system that is malfunctioning.
3. Check voltage between combination switch harness connector and ground.

NOTE:

Check that the combination switch outputs a signal from combination switch input system.

A
B
C
D
E
F
G
H
I
J
K
L
N
O
P

BCS

COMBINATION SWITCH OUTPUT CIRCUIT

< DTC/CIRCUIT DIAGNOSIS >

System	Terminals		Value (Approx.)
	(+)	(-)	
	Combination switch		
	Connector	Terminal	
OUTPUT 1	M103	12	Ground
OUTPUT 2		14	
OUTPUT 3		5	
OUTPUT 4		2	
OUTPUT 5		8	

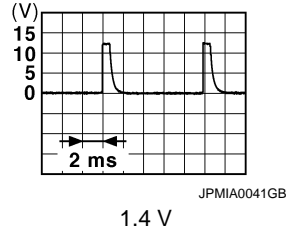

Is the measurement value normal when any of the switches is turned ON?

- YES >> Replace BCM. Refer to [BCS-98, "Exploded View"](#).
- NO >> Replace the combination switch.

BCM (BODY CONTROL MODULE)

< ECU DIAGNOSIS INFORMATION >

ECU DIAGNOSIS INFORMATION

BCM (BODY CONTROL MODULE)

Reference Value

INFOID:000000009722472

VALUES ON THE DIAGNOSIS TOOL

NOTE:

The following table includes information (items) inapplicable to this vehicle. For information (items) applicable to this vehicle, refer to CONSULT display items.

CONSULT MONITOR ITEM

Monitor Item	Condition	Value/Status
FR WIPER HI	Other than front wiper switch HI	Off
	Front wiper switch HI	On
FR WIPER LOW	Other than front wiper switch LO	Off
	Front wiper switch LO	On
FR WASHER SW	Front washer switch OFF	Off
	Front washer switch ON	On
FR WIPER INT	Other than front wiper switch INT/AUTO	Off
	Front wiper switch INT/AUTO	On
FR WIPER STOP	Front wiper is not in STOP position	Off
	Front wiper is in STOP position	On
INT VOLUME	Wiper intermittent dial is in a dial position 1 - 7	Wiper intermittent dial position
RR WIPER ON	Other than rear wiper switch ON	Off
	Rear wiper switch ON	On
RR WIPER INT	Other than rear wiper switch INT	Off
	Rear wiper switch INT	On
RR WASHER SW	Rear washer switch OFF	Off
	Rear washer switch ON	On
RR WIPER STOP	Rear wiper is in STOP position	Off
	Rear wiper is not in STOP position	On
TURN SIGNAL R	Other than turn signal switch RH	Off
	Turn signal switch RH	On
TURN SIGNAL L	Other than turn signal switch LH	Off
	Turn signal switch LH	On
TAIL LAMP SW	Other than lighting switch 1ST and 2ND	Off
	Lighting switch 1ST or 2ND	On
HI BEAM SW	Other than lighting switch HI	Off
	Lighting switch HI	On
HEAD LAMP SW 1	Other than lighting switch 2ND	Off
	Lighting switch 2ND	On
HEAD LAMP SW 2	Other than lighting switch 2ND	Off
	Lighting switch 2ND	On
PASSING SW	Other than lighting switch PASS	Off
	Lighting switch PASS	On
AUTO LIGHT SW	Other than lighting switch AUTO	Off
	Lighting switch AUTO	On

BCM (BODY CONTROL MODULE)

< ECU DIAGNOSIS INFORMATION >

Monitor Item	Condition	Value/Status
FR FOG SW	Front fog lamp switch OFF	Off
	Front fog lamp switch ON	On
RR FOG SW	NOTE: The item is indicated, but not monitored.	Off
DOOR SW-DR	Driver door closed	Off
	Driver door opened	On
DOOR SW-AS	Passenger door closed	Off
	Passenger door opened	On
DOOR SW-RR	Rear RH door closed	Off
	Rear RH door opened	On
DOOR SW-RL	Rear LH door closed	Off
	Rear LH door opened	On
DOOR SW-BK	Back door closed	Off
	Back door opened	On
CDL LOCK SW	Other than power door lock switch LOCK	Off
	Power door lock switch LOCK	On
CDL UNLOCK SW	Other than power door lock switch UNLOCK	Off
	Power door lock switch UNLOCK	On
KEY CYL LK-SW	Other than driver door key cylinder LOCK position	Off
	Driver door key cylinder LOCK position	On
KEY CYL UN-SW	Other than driver door key cylinder UNLOCK position	Off
	Driver door key cylinder UNLOCK position	On
KEY CYL SW-TR	NOTE: The item is indicated, but not monitored.	Off
HAZARD SW	Hazard switch is OFF	Off
	Hazard switch is ON	On
REAR DEF SW NOTE: For models with BOSE audio system this item is not monitored.	Rear window defogger switch OFF	Off
	Rear window defogger switch ON	On
TR CANCEL SW	NOTE: The item is indicated, but not monitored.	Off
TR/BD OPEN SW	Back door opener switch OFF	Off
	While the back door opener switch is turned ON	On
TRNK/HAT MNTR	NOTE: The item is indicated, but not monitored.	Off
RKE-LOCK	LOCK button of Intelligent Key is not pressed	Off
	LOCK button of Intelligent Key is pressed	On
RKE-UNLOCK	UNLOCK button of Intelligent Key is not pressed	Off
	UNLOCK button of Intelligent Key is pressed	On
RKE-TR/BD	BACK DOOR OPEN button of Intelligent Key is not pressed	Off
	BACK DOOR OPEN button of Intelligent Key is pressed	On
RKE-PANIC	PANIC button of Intelligent Key is not pressed	Off
	PANIC button of Intelligent Key is pressed	On
RKE-P/W OPEN	UNLOCK button of Intelligent Key is not pressed	Off
	UNLOCK button of Intelligent Key is pressed and held	On

BCM (BODY CONTROL MODULE)

< ECU DIAGNOSIS INFORMATION >

Monitor Item	Condition	Value/Status	
RKE-MODE CHG	LOCK/UNLOCK button of Intelligent Key is not pressed and held simultaneously	Off	A
	LOCK/UNLOCK button of Intelligent Key is pressed and held simultaneously	On	B
OPTICAL SENSOR	Bright outside of the vehicle	Close to 5 V	C
	Dark outside of the vehicle	Close to 0 V	
REQ SW -DR	Driver door request switch is not pressed	Off	D
	Driver door request switch is pressed	On	
REQ SW -AS	Passenger door request switch is not pressed	Off	E
	Passenger door request switch is pressed	On	
REQ SW -RR	NOTE: The item is indicated, but not monitored.	Off	F
REQ SW -RR	NOTE: The item is indicated, but not monitored.	Off	G
REQ SW -BD/TR	Back door request switch is not pressed	Off	H
	Back door request switch is pressed	On	
PUSH SW	Push-button ignition switch (push switch) is not pressed	Off	I
	Push-button ignition switch (push switch) is pressed	On	
IGN RLY2 -F/B	Ignition switch in OFF or ACC position	Off	J
	Ignition switch in ON position	On	
ACC RLY -F/B	NOTE: The item is indicated, but not monitored.	Off	K
CLUCH SW	NOTE: The item is indicated, but not monitored.	Off	L
BRAKE SW 1	The brake pedal is depressed when No. 7 fuse is blown	Off	BCS
	The brake pedal is not depressed when No. 7 fuse is blown, or No. 7 fuse is normal	On	
BRAKE SW 2	The brake pedal is not depressed	Off	N
	Stop lamp switch 1 signal circuit is normal	On	
DETE/CANCL SW	Selector lever in P position	Off	O
	Selector lever in any position other than P	On	
SFT PN/N SW	Selector lever in any position other than P and N	Off	P
	Selector lever in P or N position	On	
S/L -LOCK	NOTE: The item is indicated, but not monitored.	Off	
S/L -UNLOCK	NOTE: The item is indicated, but not monitored.	Off	
S/L RELAY-F/B	NOTE: The item is indicated, but not monitored.	Off	
UNLK SEN -DR	Driver door is unlocked	Off	
	Driver door is locked	On	
PUSH SW -IPDM	Push-button ignition switch (push-switch) is not pressed	Off	
	Push-button ignition switch (push-switch) is pressed	On	
IGN RLY1 -F/B	Ignition switch in OFF or ACC position	Off	
	Ignition switch in ON position	On	
DETE SW -IPDM	Selector lever in any position other than P	Off	
	Selector lever in P position	On	

BCM (BODY CONTROL MODULE)

< ECU DIAGNOSIS INFORMATION >

Monitor Item	Condition	Value/Status
SFT PN -IPDM	Selector lever in any position other than P and N	Off
	Selector lever in P or N position	On
SFT P -MET	Selector lever in any position other than P	Off
	Selector lever in P position	On
SFT N -MET	Selector lever in any position other than N	Off
	Selector lever in N position	On
ENGINE STATE	Engine stopped	Stop
	While the engine stalls	Stall
	At engine cranking	Crank
	Engine running	Run
S/L LOCK-IPDM	NOTE: The item is indicated, but not monitored.	Off
S/L UNLK-IPDM	NOTE: The item is indicated, but not monitored.	Off
S/L RELAY-REQ	NOTE: The item is indicated, but not monitored.	Off
VEH SPEED 1	While driving	Equivalent to speedometer reading
VEH SPEED 2	While driving	Equivalent to speedometer reading
DOOR STAT-DR	Driver door is locked	LOCK
	Wait with selective UNLOCK operation (5 seconds)	READY
	Driver door is unlocked	UNLOCK
DOOR STAT-AS	Passenger door is locked	LOCK
	Wait with selective UNLOCK operation (5 seconds)	READY
	Passenger door is unlocked	UNLOCK
ID OK FLAG	Power supply position in LOCK position	Reset
	Power supply position in any position other than LOCK	Set
PRMT ENG STRT	The engine start is prohibited	Reset
	The engine start is permitted	Set
PRMT RKE STRT	NOTE: The item is indicated, but not monitored.	Reset
KEY SW -SLOT	Intelligent Key is not inserted into key slot	Off
	Intelligent Key is inserted into key slot	On
RKE OPE COUN1	During the operation of Intelligent Key	Operation frequency of Intelligent Key
RKE OPE COUN2	NOTE: The item is indicated, but not monitored.	—
CONFIRM ID ALL	The Intelligent Key ID that the key slot receives is not recognized by any Intelligent Key ID registered to BCM.	Yet
	The Intelligent Key ID that the key slot receives is recognized by any Intelligent Key ID registered to BCM.	Done
CONFIRM ID4	The Intelligent Key ID that the key slot receives is not recognized by the fourth Intelligent Key ID registered to BCM.	Yet
	The Intelligent Key ID that the key slot receives is recognized by the fourth Intelligent Key ID registered to BCM.	Done

BCM (BODY CONTROL MODULE)

< ECU DIAGNOSIS INFORMATION >

Monitor Item	Condition	Value/Status	
CONFIRM ID3	The Intelligent Key ID that the key slot receives is not recognized by the third Intelligent Key ID registered to BCM.	Yet	A
	The Intelligent Key ID that the key slot receives is recognized by the third Intelligent Key ID registered to BCM.	Done	B
CONFIRM ID2	The Intelligent Key ID that the key slot receives is not recognized by the second Intelligent Key ID registered to BCM.	Yet	C
	The Intelligent Key ID that the key slot receives is recognized by the second Intelligent Key ID registered to BCM.	Done	
CONFIRM ID1	The Intelligent Key ID that the key slot receives is not recognized by the first Intelligent Key ID registered to BCM.	Yet	D
	The Intelligent Key ID that the key slot receives is recognized by the first Intelligent Key ID registered to BCM.	Done	
TP 4	The ID of fourth Intelligent Key is not registered to BCM	Yet	E
	The ID of fourth Intelligent Key is registered to BCM	Done	
TP 3	The ID of third Intelligent Key is not registered to BCM	Yet	F
	The ID of third Intelligent Key is registered to BCM	Done	
TP 2	The ID of second Intelligent Key is not registered to BCM	Yet	G
	The ID of second Intelligent Key is registered to BCM	Done	
TP 1	The ID of first Intelligent Key is not registered to BCM	Yet	H
	The ID of first Intelligent Key is registered to BCM	Done	
AIR PRESS FL	Ignition switch ON (Only when the signal from the transmitter is received)	Air pressure of front LH tire	I
AIR PRESS FR	Ignition switch ON (Only when the signal from the transmitter is received)	Air pressure of front RH tire	J
AIR PRESS RR	Ignition switch ON (Only when the signal from the transmitter is received)	Air pressure of rear RH tire	K
AIR PRESS RL	Ignition switch ON (Only when the signal from the transmitter is received)	Air pressure of rear LH tire	L
ID REGST FL1	ID of front LH tire transmitter is registered	Done	BCS
	ID of front LH tire transmitter is not registered	Yet	
ID REGST FR1	ID of front RH tire transmitter is registered	Done	N
	ID of front RH tire transmitter is not registered	Yet	
ID REGST RR1	ID of rear RH tire transmitter is registered	Done	O
	ID of rear RH tire transmitter is not registered	Yet	
ID REGST RL1	ID of rear LH tire transmitter is registered	Done	P
	ID of rear LH tire transmitter is not registered	Yet	
WARNING LAMP	Tire pressure indicator OFF	Off	
	Tire pressure indicator ON	On	
BUZZER	Tire pressure warning alarm is not sounding	Off	
	Tire pressure warning alarm is sounding	On	

BCM (BODY CONTROL MODULE)

< ECU DIAGNOSIS INFORMATION >

TERMINAL LAYOUT

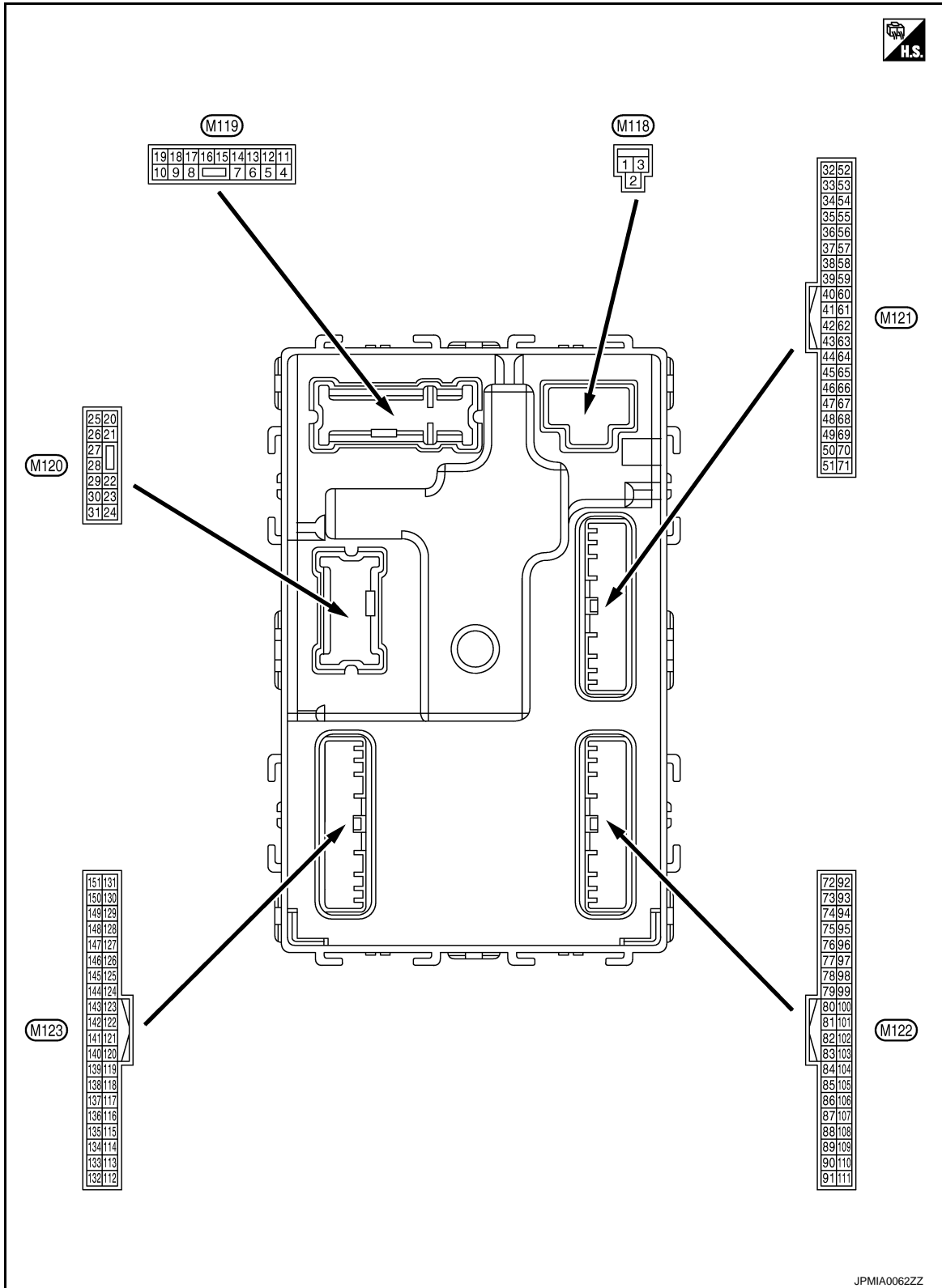

PHYSICAL VALUES

BCM (BODY CONTROL MODULE)

< ECU DIAGNOSIS INFORMATION >

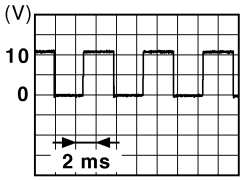
Terminal No. (Wire color)		Description		Condition		Value (Approx.)
		Signal name	Input/ Output			
+	-					
1 (W)	Ground	Battery power supply	Input	Ignition switch OFF		Battery voltage
2 (GR)	Ground	P/W power supply (BAT)	Output	Ignition switch OFF		Battery voltage
3 (L)	Ground	P/W power supply (IGN)	Output	Ignition switch ON		Battery voltage
4 (P/W)	Ground	Interior room lamp power supply	Output	Interior room lamp battery saver is activated. (Cuts the interior room lamp power supply)		0 V
				Interior room lamp battery saver is not activated. (Outputs the interior room lamp power supply)		Battery voltage
5 (G)	Ground	Passenger door UN- LOCK	Output	Passenger door	UNLOCK (Actuator is activated)	Battery voltage
					Other than UNLOCK (Actuator is not activated)	0 V
7 (W)	Ground	Step lamp control	Output	Step lamp	ON	0 V
					OFF	Battery voltage
8 (V)	Ground	All doors LOCK	Output	All doors	LOCK (Actuator is activated)	Battery voltage
					Other than LOCK (Actuator is not activated)	0 V
9 (G)	Ground	Driver door UNLOCK	Output	Driver door	UNLOCK (Actuator is activated)	Battery voltage
					Other than UNLOCK (Actuator is not activated)	0 V
10 (P)	Ground	Rear RH door and rear LH door UN- LOCK	Output	Rear RH door and rear LH door	UNLOCK (Actuator is activated)	Battery voltage
					Other than UNLOCK (Actuator is not activated)	0 V
11 (LG)	Ground	Battery power supply	Input	Ignition switch OFF		Battery voltage
13 (B)	Ground	Ground	—	Ignition switch ON		0 V
14 (O)	Ground	Push-button ignition switch illumination ground	Output	Tail lamp	OFF	0 V
					ON	<p>NOTE: When the illumination brightening/dimming level is in the neutral position</p>  <p style="text-align: right; font-size: small;">JSNIA0010GB</p>
15 (L)	Ground	ACC indicator lamp	Output	Ignition switch	OFF (LOCK and ON indicator lamps are not illuminated.)	Battery voltage
					ACC	0 V

A
B
C
D
E
F
G
H
I
J
K
L
N
O
P

BCS

BCM (BODY CONTROL MODULE)

< ECU DIAGNOSIS INFORMATION >

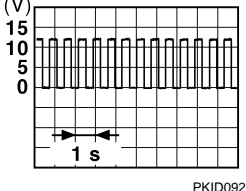
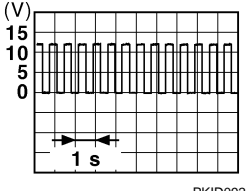
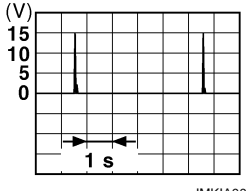
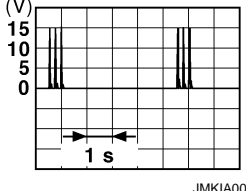
Terminal No. (Wire color)		Description		Condition	Value (Approx.)
+	-	Signal name	Input/ Output		
17 (G)	Ground	Turn signal RH	Output	Ignition switch ON	Turn signal switch OFF Turn signal switch RH
				0 V	 6.5 V
18 (BR)	Ground	Turn signal LH	Output	Ignition switch ON	Turn signal switch OFF Turn signal switch LH
				0 V	 6.5 V
19 (Y)	Ground	Interior room lamp control	Output	Interior room lamp	OFF ON
				Battery voltage 0 V	
23 (BR)	Ground	Back door open	Output	Back door	OPEN (Back door opener actuator is activated) Other than OPEN (Back door opener actuator is not activated)
				Battery voltage 0 V	
26 (G)	Ground	Rear wiper	Output	Rear wiper	OFF (Stopped) ON (Operated)
				0 V Battery voltage	
34 (B)	Ground	Luggage room anten- na (-)	Output	Ignition switch OFF	When Intelligent Key is in the passenger compart- ment
				 JMKIA0062GB	
				When Intelligent Key is not in the passenger compart- ment	 JMKIA0063GB

BCM (BODY CONTROL MODULE)

< ECU DIAGNOSIS INFORMATION >

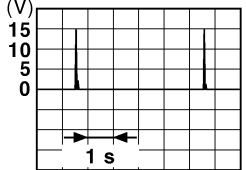
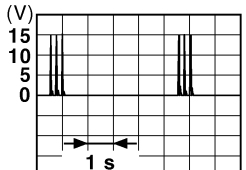
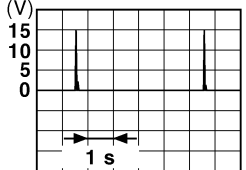
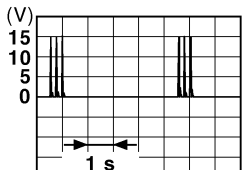
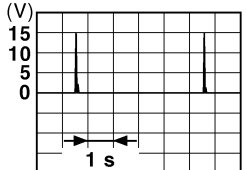
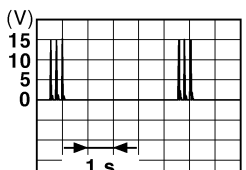
Terminal No. (Wire color)		Description		Condition	Value (Approx.)
		Signal name	Input/ Output		
+	-				
35 (W)	Ground	Luggage room antenna (+)	Output	Ignition switch OFF	When Intelligent Key is in the passenger compartment  JMKIA0062GB
					When Intelligent Key is not in the passenger compartment  JMKIA0063GB
38 (L)	Ground	Rear bumper antenna (-)	Output	When the back door request switch is operated with ignition switch OFF	When Intelligent Key is in the antenna detection area  JMKIA0062GB
					When Intelligent Key is not in the antenna detection area  JMKIA0063GB
39 (BR)	Ground	Rear bumper antenna (+)	Output	When the back door request switch is operated with ignition switch OFF	When Intelligent Key is in the antenna detection area  JMKIA0062GB
					When Intelligent Key is not in the antenna detection area  JMKIA0063GB
47 (L)	Ground	Ignition relay (IPDM E/R) control	Output	Ignition switch	OFF or ACC Battery voltage
					ON 0 V

A
B
C
D
E
F
G
H
I
J
K
L
N
O
P

BCS

BCM (BODY CONTROL MODULE)

< ECU DIAGNOSIS INFORMATION >

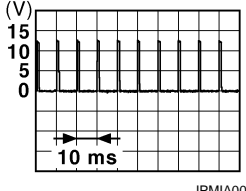
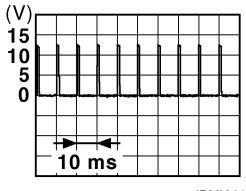
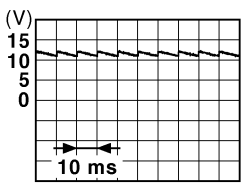
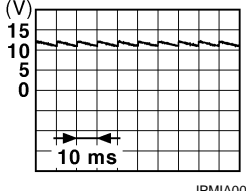
Terminal No. (Wire color)		Description		Condition		Value (Approx.)
+	-	Signal name	Input/ Output			
52 (R)	Ground	Starter relay control	Output	Ignition switch ON	When selector lever is in P or N position	Battery voltage
					When selector lever is not in P or N position	0.3 V
				Ignition switch OFF		0 V
60 (BR)	Ground	Push-button ignition switch (push switch)	Input	Push-button igni- tion switch (push switch)	Pressed	0 V
					Not pressed	Battery voltage
61 (R)	Ground	Back door request switch	Input	Back door re- quest switch	ON (Pressed)	0 V
					OFF (Not pressed)	 1.0 V
64 (GR)	Ground	Intelligent key warn- ing buzzer control	Output	Warning buzzer	Sounding	0 V
					Not sounding	Battery voltage
65 (O)	Ground	Rear wiper stop posi- tion	Input	Rear wiper	In stop position	 1.0 V
					Not in stop position	0 V
66 (Y)	Ground	Back door switch	Input	Back door switch	OFF (When back door closes)	 11.8 V
					ON (When back door opens)	0 V
67 (LG)	Ground	Back door opener switch	Input	Back door opener switch	Pressed	0 V
					Not pressed	 11.8 V

BCM (BODY CONTROL MODULE)

< ECU DIAGNOSIS INFORMATION >

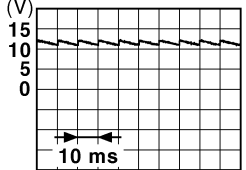
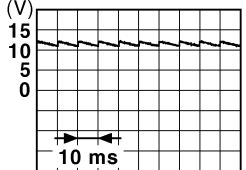
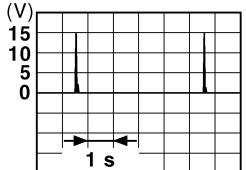
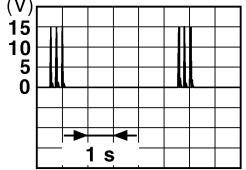
Terminal No. (Wire color)		Description		Condition	Value (Approx.)
+	-	Signal name	Input/ Output		
68 (W)	Ground	Rear RH door switch	Input	Rear RH door switch	 <p style="text-align: center;">11.8 V</p>
				OFF (When rear RH door closes)	0 V
69 (R)	Ground	Rear LH door switch	Input	Rear LH door switch	 <p style="text-align: center;">11.8 V</p>
				OFF (When rear LH door closes)	0 V
72 (B)	Ground	Room antenna (-) (Center console)	Output	Ignition switch OFF	 <p style="text-align: center;">11.8 V</p>
				When Intelligent Key is in the passenger compartment	 <p style="text-align: center;">11.8 V</p>

A
B
C
D
E
F
G
H
I
J
K
L
N
O
P

BCS

BCM (BODY CONTROL MODULE)

< ECU DIAGNOSIS INFORMATION >

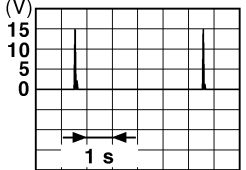
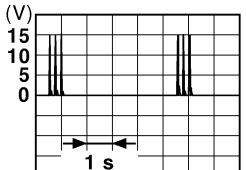
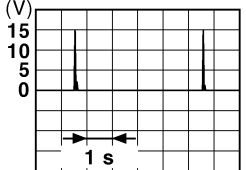
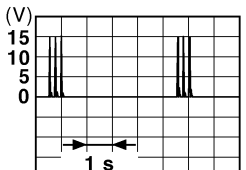
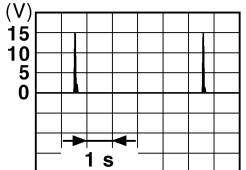
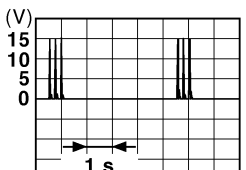
Terminal No. (Wire color)		Description		Condition	Value (Approx.)
+	-	Signal name	Input/ Output		
73 (W)	Ground	Room antenna (+) (Center console)	Output	Ignition switch OFF	<p>When Intelligent Key is in the passenger compartment</p>  <p style="text-align: right; font-size: small;">JMKIA0062GB</p>
				<p>When Intelligent Key is not in the passenger compartment</p>  <p style="text-align: right; font-size: small;">JMKIA0063GB</p>	
74 (Y)	Ground	Passenger door antenna (-)	Output	When the passenger door request switch is operated with ignition switch OFF	<p>When Intelligent Key is in the antenna detection area</p>  <p style="text-align: right; font-size: small;">JMKIA0062GB</p>
				<p>When Intelligent Key is not in the antenna detection area</p>  <p style="text-align: right; font-size: small;">JMKIA0063GB</p>	
75 (LG)	Ground	Passenger door antenna (+)	Output	When the passenger door request switch is operated with ignition switch OFF	<p>When Intelligent Key is in the antenna detection area</p>  <p style="text-align: right; font-size: small;">JMKIA0062GB</p>
				<p>When Intelligent Key is not in the antenna detection area</p>  <p style="text-align: right; font-size: small;">JMKIA0063GB</p>	

BCM (BODY CONTROL MODULE)

< ECU DIAGNOSIS INFORMATION >





Terminal No. (Wire color)		Description		Condition	Value (Approx.)
+	-	Signal name	Input/ Output		
76 (V)	Ground	Driver door antenna (-)	Output	When the driver door request switch is operated with ignition switch OFF	
				When Intelligent Key is in the antenna detection area	
77 (P)	Ground	Driver door antenna (+)	Output	When the driver door request switch is operated with ignition switch OFF	
				When Intelligent Key is not in the antenna detection area	
80 (SB)	Ground	NATS antenna amp.	Input/ Output	During waiting	
				Ignition switch is pressed while inserting Intelligent Key into the key slot.	
81 (O)	Ground	NATS antenna amp.	Input/ Output	During waiting	
82 (BR)	Ground	Ignition relay [fuse block (J/B)] control	Output	Ignition switch	0 V
				OFF or ACC	Battery voltage
					ON

A
B
C
D
E
F
G
H
I
J
K
L
N
O
P

BCS

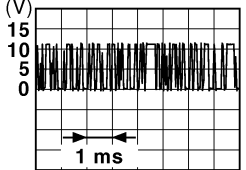
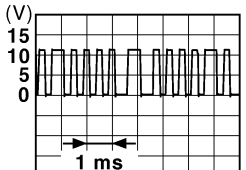

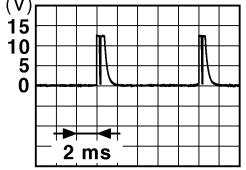
BCM (BODY CONTROL MODULE)

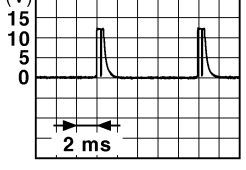
< ECU DIAGNOSIS INFORMATION >

Terminal No. (Wire color)		Description		Condition	Value (Approx.)
+	-	Signal name	Input/ Output		
83 (P)	Ground	Remote keyless entry receiver communication	Input/ Output	During waiting	 <p style="text-align: right; font-size: small;">JMKIA0064GB</p>
				When operating either button on Intelligent Key	 <p style="text-align: right; font-size: small;">JMKIA0065GB</p>
87 (R)	Ground	Combination switch INPUT 5	Input	Combination switch	<p>All switches OFF (Wiper intermittent dial 4)</p>  <p style="text-align: right; font-size: small;">JPMIA0041GB</p> <p style="text-align: center;">1.4 V</p>
				Combination switch	<p>Front fog lamp switch ON (Wiper intermittent dial 4)</p>  <p style="text-align: right; font-size: small;">JPMIA0037GB</p> <p style="text-align: center;">1.3 V</p>
				Combination switch	<p>Rear wiper switch ON (Wiper intermittent dial 4)</p>  <p style="text-align: right; font-size: small;">JPMIA0039GB</p> <p style="text-align: center;">1.3 V</p>
				Combination switch	<p>Any of the conditions below with all switches OFF</p> <ul style="list-style-type: none"> • Wiper intermittent dial 1 • Wiper intermittent dial 2 • Wiper intermittent dial 6 • Wiper intermittent dial 7  <p style="text-align: right; font-size: small;">JPMIA0040GB</p> <p style="text-align: center;">1.3 V</p>

BCM (BODY CONTROL MODULE)

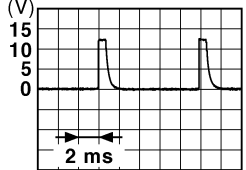
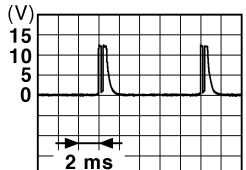
< ECU DIAGNOSIS INFORMATION >

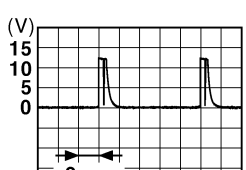
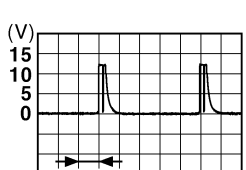
Terminal No. (Wire color)		Description		Condition	Value (Approx.)	
+	-	Signal name	Input/ Output			
88 (GR)	Ground	Combination switch INPUT 3	Input	Combination switch	All switches OFF (Wiper intermittent dial 4)	 <p style="text-align: right;">1.4 V</p>
					Lighting switch HI (Wiper intermittent dial 4)	 <p style="text-align: right;">1.3 V</p>
					Lighting switch 2ND (Wiper intermittent dial 4)	 <p style="text-align: right;">1.3 V</p>
					Rear washer switch ON (Wiper intermittent dial 4)	 <p style="text-align: right;">1.3 V</p>
					Any of the conditions below with all switches OFF	 <p style="text-align: right;">1.3 V</p>
					<ul style="list-style-type: none"> • Wiper intermittent dial 1 • Wiper intermittent dial 2 • Wiper intermittent dial 3 	
90 (P)	Ground	CAN-L	Input/ Output	—	—	
91 (L)	Ground	CAN-H	Input/ Output	—	—	

A
B
C
D
E
F
G
H
I
J
K
L
N
O
P

BCS

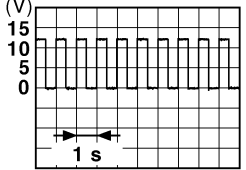
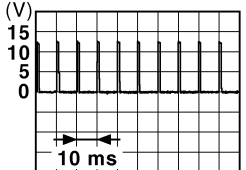
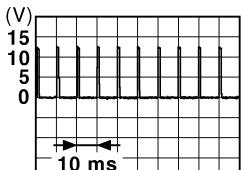

BCM (BODY CONTROL MODULE)

< ECU DIAGNOSIS INFORMATION >

Terminal No. (Wire color)		Description		Condition		Value (Approx.)
+	-	Signal name	Input/ Output			
92 (R)	Ground	Key slot illumination	Output	Key slot illumination	OFF	0 V
					Blinking	 <p style="text-align: right; font-size: small;">JPMA0015GB</p>
					ON	Battery voltage
93 (P)	Ground	ON indicator lamp	Output	Ignition switch	OFF (LOCK and ACC indicator lamps are not illuminated.)	Battery voltage
					ON	0 V
95 (L)	Ground	ACC relay control	Output	Ignition switch	OFF	0 V
					ACC or ON	Battery voltage
96 (Y)	Ground	CVT shift selector (detention switch) power supply	Output	—	—	Battery voltage
99 (V)	Ground	Selector lever P position switch	Input	Selector lever	P position	0 V
					Any position other than P	Battery voltage
100 (P)	Ground	Passenger door request switch	Input	Passenger door request switch	ON (Pressed)	0 V
					OFF (Not pressed)	 <p style="text-align: right; font-size: small;">JPMA0016GB</p>
101 (W)	Ground	Driver door request switch	Input	Driver door request switch	ON (Pressed)	0 V
					OFF (Not pressed)	 <p style="text-align: right; font-size: small;">JPMA0016GB</p>
102 (Y)	Ground	Blower fan motor relay control	Output	Ignition switch	OFF or ACC	0 V
					ON	Battery voltage
103 (L)	Ground	Remote keyless entry receiver power supply	Output	Ignition switch OFF	—	Battery voltage

BCM (BODY CONTROL MODULE)

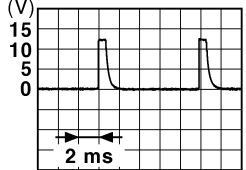
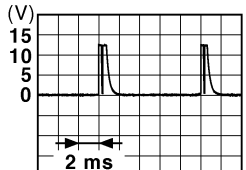
< ECU DIAGNOSIS INFORMATION >

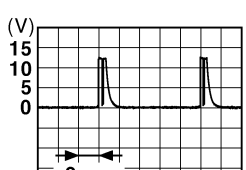
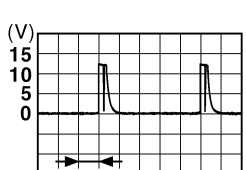
Terminal No. (Wire color)		Description		Condition	Value (Approx.)	
		Signal name	Input/ Output			
+	-					
107 (O)	Ground	Combination switch INPUT 1	Input	Combination switch (Wiper intermittent dial 4)	All switches OFF	 1.4 V
					Turn signal switch LH	 1.3 V
					Turn signal switch RH	 1.3 V
					Front wiper switch LO	 1.3 V
					Front washer switch ON	 1.3 V

A
B
C
D
E
F
G
H
I
J
K
L
N
O
P

BCS

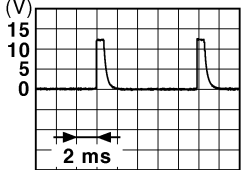
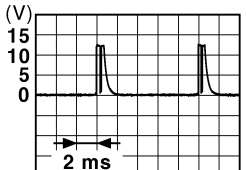
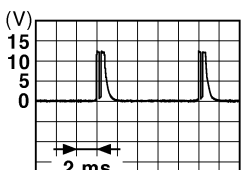
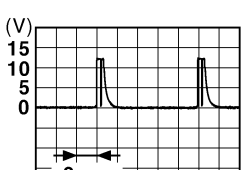
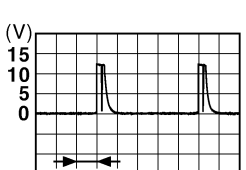

BCM (BODY CONTROL MODULE)

< ECU DIAGNOSIS INFORMATION >

Terminal No. (Wire color)		Description		Condition	Value (Approx.)	
		Signal name	Input/ Output			
+	-					
108 (P)	Ground	Combination switch INPUT 4	Input	Combination switch	All switches OFF (Wiper intermittent dial 4)	 <p style="text-align: right; font-size: small;">JPMIA0041GB</p> <p style="text-align: center;">1.4 V</p>
					Lighting switch AUTO (Wiper intermittent dial 4)	 <p style="text-align: right; font-size: small;">JPMIA0038GB</p> <p style="text-align: center;">1.3 V</p>
					Lighting switch 1ST (Wiper intermittent dial 4)	 <p style="text-align: right; font-size: small;">JPMIA0036GB</p> <p style="text-align: center;">1.3 V</p>
					Rear wiper switch INT (Wiper intermittent dial 4)	 <p style="text-align: right; font-size: small;">JPMIA0040GB</p> <p style="text-align: center;">1.3 V</p>
					Any of the conditions below with all switches OFF	 <p style="text-align: right; font-size: small;">JPMIA0039GB</p> <p style="text-align: center;">1.3 V</p>

BCM (BODY CONTROL MODULE)

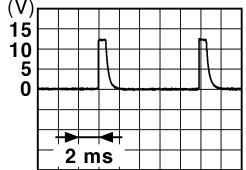
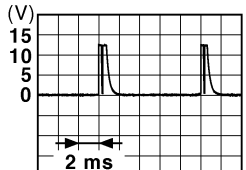
< ECU DIAGNOSIS INFORMATION >

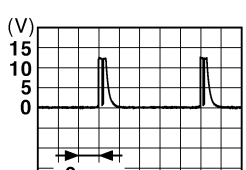
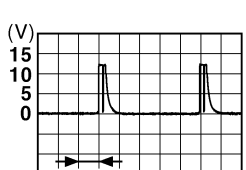
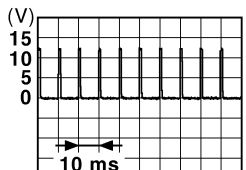
Terminal No. (Wire color)		Description		Condition	Value (Approx.)	
+	-	Signal name	Input/ Output			
109 (SB)	Ground	Combination switch INPUT 2	Input	Combination switch (Wiper intermit- tent dial 4)	All switches OFF	 <p style="text-align: right;">1.4 V</p>
					Lighting switch PASS	 <p style="text-align: right;">1.3 V</p>
					Lighting switch 2ND	 <p style="text-align: right;">1.3 V</p>
					Front wiper switch INT/ AUTO	 <p style="text-align: right;">1.3 V</p>
					Front wiper switch HI	 <p style="text-align: right;">1.3 V</p>
					ON	0 V
110 (G)	Ground	Hazard switch	Input	Hazard switch	 <p style="text-align: right;">1.1 V</p>	
				OFF		

A
B
C
D
E
F
G
H
I
J
K
L
N
O
P

BCS

BCM (BODY CONTROL MODULE)

< ECU DIAGNOSIS INFORMATION >

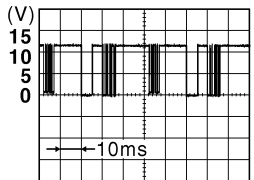
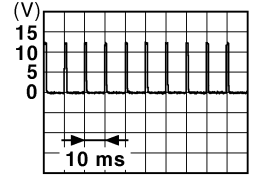
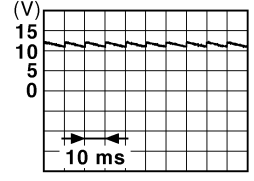
Terminal No. (Wire color)		Description		Condition		Value (Approx.)
+	-	Signal name	Input/ Output			
112 (R)	Ground	Rain sensor serial link	Input/ Output	Ignition switch ON		 8.7 V
113 (P/B)	Ground	Optical sensor	Input	Ignition switch ON	When bright outside of the vehicle	Close to 5 V
					When dark outside of the vehicle	Close to 0 V
116 (GR)	Ground	Stop lamp switch 1	Input	—		Battery voltage
118 (L)	Ground	Stop lamp switch 2	Input	Stop lamp switch	OFF (Brake pedal is not depressed)	0 V
					ON (Brake pedal is depressed)	Battery voltage
119 (W)	Ground	Front door lock assembly driver side (Unlock sensor)	Input	Driver door	LOCK status (unlock sensor switch OFF)	 1.1 V
					UNLOCK status (unlock sensor switch ON)	0 V
121 (Y)	Ground	Key slot switch	Input	When Intelligent Key is inserted into key slot		Battery voltage
				When Intelligent Key is not inserted into key slot		0 V
123 (G)	Ground	IGN feedback	Input	Ignition switch		OFF or ACC
				ON		Battery voltage
124 (R)	Ground	Passenger door switch	Input	Passenger door switch	OFF (When passenger door closes)	 11.8 V
					ON (When passenger door opens)	0 V

BCM (BODY CONTROL MODULE)

< ECU DIAGNOSIS INFORMATION >

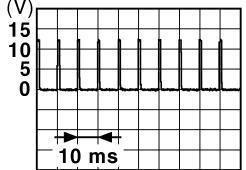
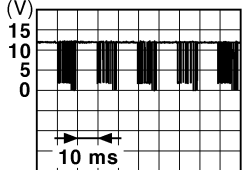
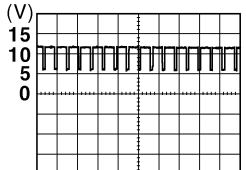

Terminal No. (Wire color)		Description		Condition	Value (Approx.)
		Signal name	Input/ Output		
+	-				
130 (BR)	Ground	Rear window defogger switch	Input	Ignition switch ON	 <p style="text-align: right; font-size: small;">JPMIA0012GB</p>
				Rear window defogger switch ON	0 V
132 (G)	Ground	Power window switch communication	Input/ Output	Ignition switch ON	 <p style="text-align: right; font-size: small;">JPMIA0013GB</p>
				Ignition switch OFF or ACC	Battery voltage
133 (W)	Ground	Push-button ignition switch illumination	Output	ON (When tail lamps OFF)	9.5 V
				ON (When tail lamps ON)	<p>NOTE: The pulse width of this wave is varied by the illumination brightening/dimming level.</p>  <p style="text-align: right; font-size: small;">JPMIA0159GB</p>
134 (R)	Ground	LOCK indicator lamp	Output	LOCK indicator lamp	OFF (ACC and ON indicator lamps are not illuminated.)
				OFF	0 V
137 (P)	Ground	Receiver and sensor ground	Input	Ignition switch ON	0 V
				OFF	0 V
138 (V)	Ground	Receiver and sensor power supply	Output	Ignition switch	OFF
				ACC or ON	5.0 V

A
B
C
D
E
F
G
H
I
J
K
L
N
O
P

BCS

BCM (BODY CONTROL MODULE)

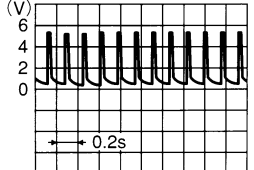
< ECU DIAGNOSIS INFORMATION >

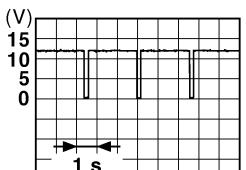
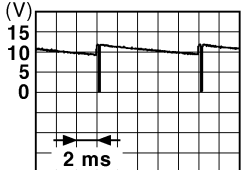
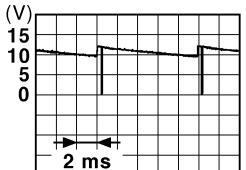
Terminal No. (Wire color)		Description		Condition	Value (Approx.)
+	-	Signal name	Input/ Output		
139 (O)	Ground	Tire pressure receiver communication	Input/ Output	Ignition switch ON	Standby state  OCC3881D
				When receiving the signal from the transmitter  OCC3880D	
140 (GR)	Ground	Selector lever P/N position	Input	Selector lever	P or N position Battery voltage
				Except P and N positions	0 V
141 (O)	Ground	Security indicator	Output	Security indicator	ON 0 V
				Blinking  JPMA0014GB 11.3 V	
				OFF Battery voltage	
142 (L)	Ground	Combination switch OUTPUT 5	Output	Combination switch (Wiper intermittent dial 4)	All switches OFF 0 V
				Lighting switch 1ST	 JPMA0031GB 10.7 V
				Lighting switch HI	
				Lighting switch 2ND	
Turn signal switch RH					
143 (W)	Ground	Combination switch OUTPUT 1	Output	Combination switch	All switches OFF (Wiper intermittent dial 4) 0 V
				Front wiper switch HI (Wiper intermittent dial 4)	 JPMA0032GB 10.7 V
				Rear wiper switch INT (Wiper intermittent dial 4)	
				Any of the conditions below with all switches OFF • Wiper intermittent dial 1 • Wiper intermittent dial 2 • Wiper intermittent dial 3 • Wiper intermittent dial 6 • Wiper intermittent dial 7	

BCM (BODY CONTROL MODULE)

< ECU DIAGNOSIS INFORMATION >

Terminal No. (Wire color)		Description		Condition	Value (Approx.)	
+	-	Signal name	Input/ Output			
144 (P)	Ground	Combination switch OUTPUT 2	Output	Combination switch	All switches OFF (Wiper intermittent dial 4)	0 V
					Front washer switch ON (Wiper intermittent dial 4)	
					Rear wiper switch ON (Wiper intermittent dial 4)	
					Rear washer switch ON (Wiper intermittent dial 4)	
					Any of the conditions below with all switches OFF <ul style="list-style-type: none"> • Wiper intermittent dial 1 • Wiper intermittent dial 5 • Wiper intermittent dial 6 	
145 (V)	Ground	Combination switch OUTPUT 3	Output	Combination switch (Wiper intermit- tent dial 4)	All switches OFF	0 V
					Front wiper switch INT/ AUTO	
					Front wiper switch LO	
					Lighting switch AUTO	
146 (Y)	Ground	Combination switch OUTPUT 4	Output	Combination switch (Wiper intermit- tent dial 4)	All switches OFF	0 V
					Front fog lamp switch ON	
					Lighting switch 2ND	
					Lighting switch PASS	
					Turn signal switch LH	
150 (SB)	Ground	Driver door switch	Input	Driver door switch	OFF (When driver door closes)	 11.8 V
					ON (When driver door opens)	0 V
151 (G)	Ground	Rear window defog- ger relay control	Output	Rear window de- fogger	Active	0 V
					Not activated	Battery voltage

A
B
C
D
E
F
G
H
I
J
K
L
N
O
P

BCS

BCM (BODY CONTROL MODULE)

< ECU DIAGNOSIS INFORMATION >

Wiring Diagram - BCM -

INFOID:00000009722473

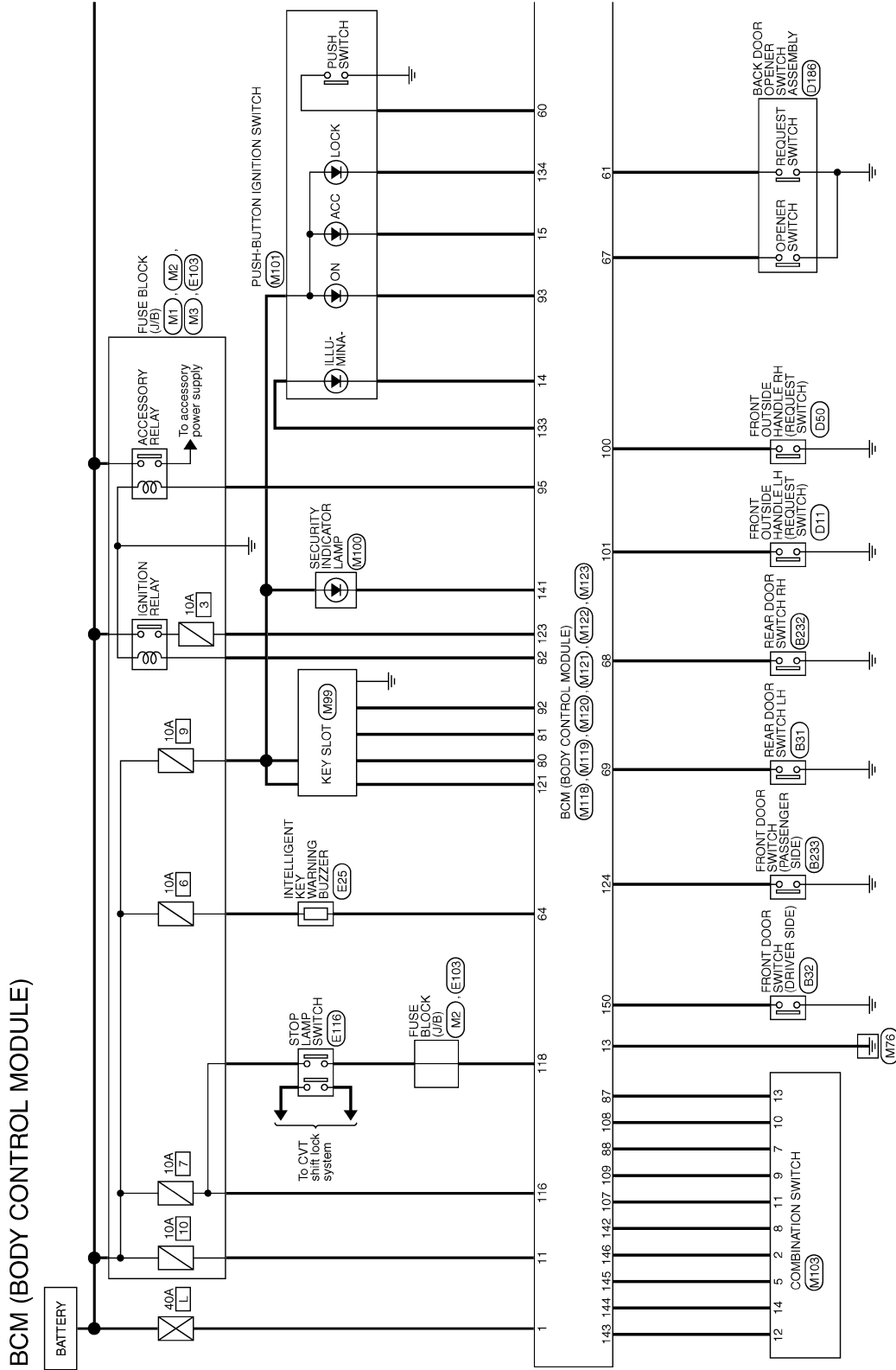

BCM (BODY CONTROL MODULE)

< ECU DIAGNOSIS INFORMATION >

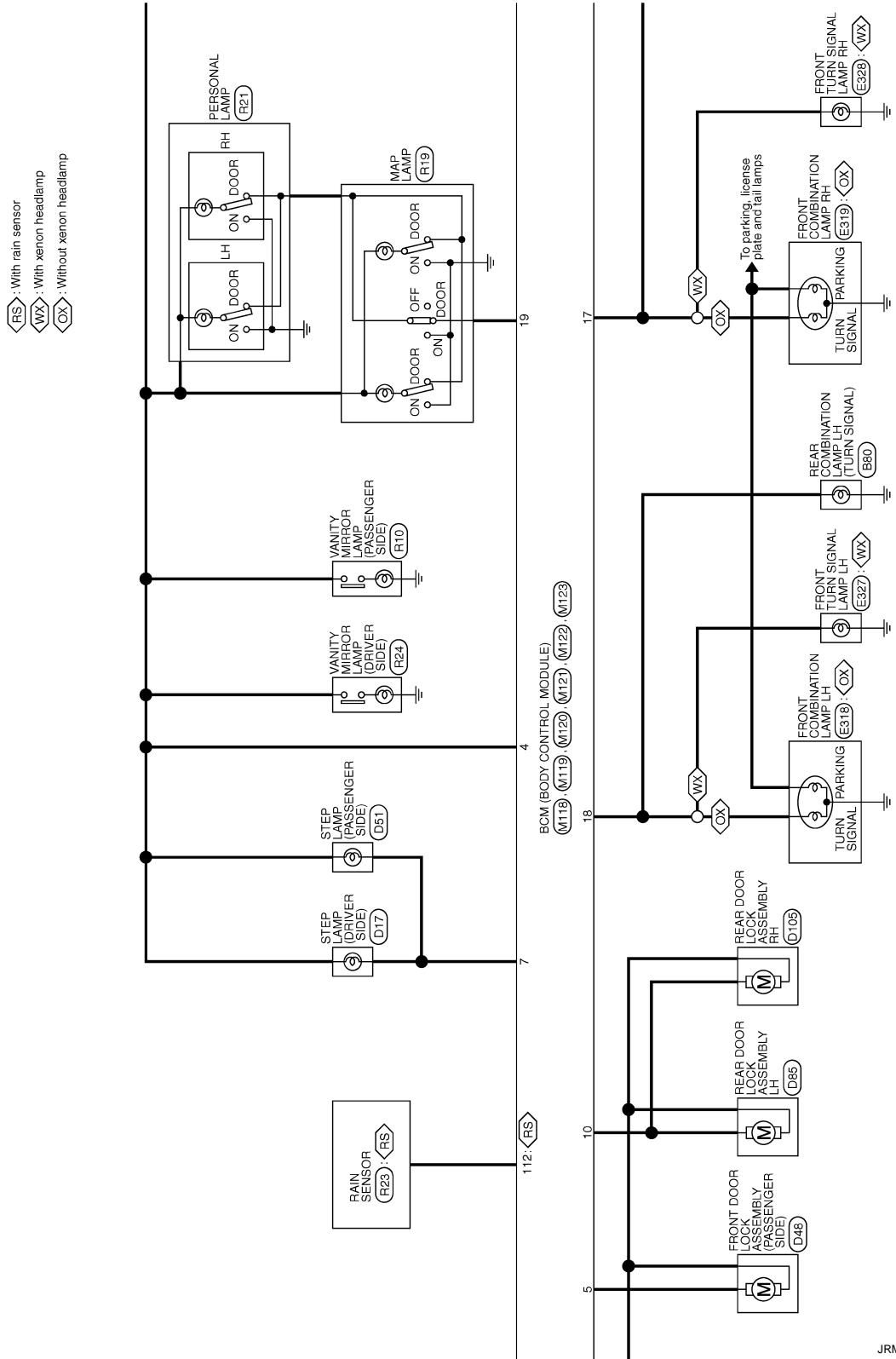

JRMWC5027GB

A
B
C
D
E
F
G
H
I
J
K
L
N
O
P

BCS

BCM (BODY CONTROL MODULE)

< ECU DIAGNOSIS INFORMATION >

AB : With automatic back door
OA : Without automatic back door

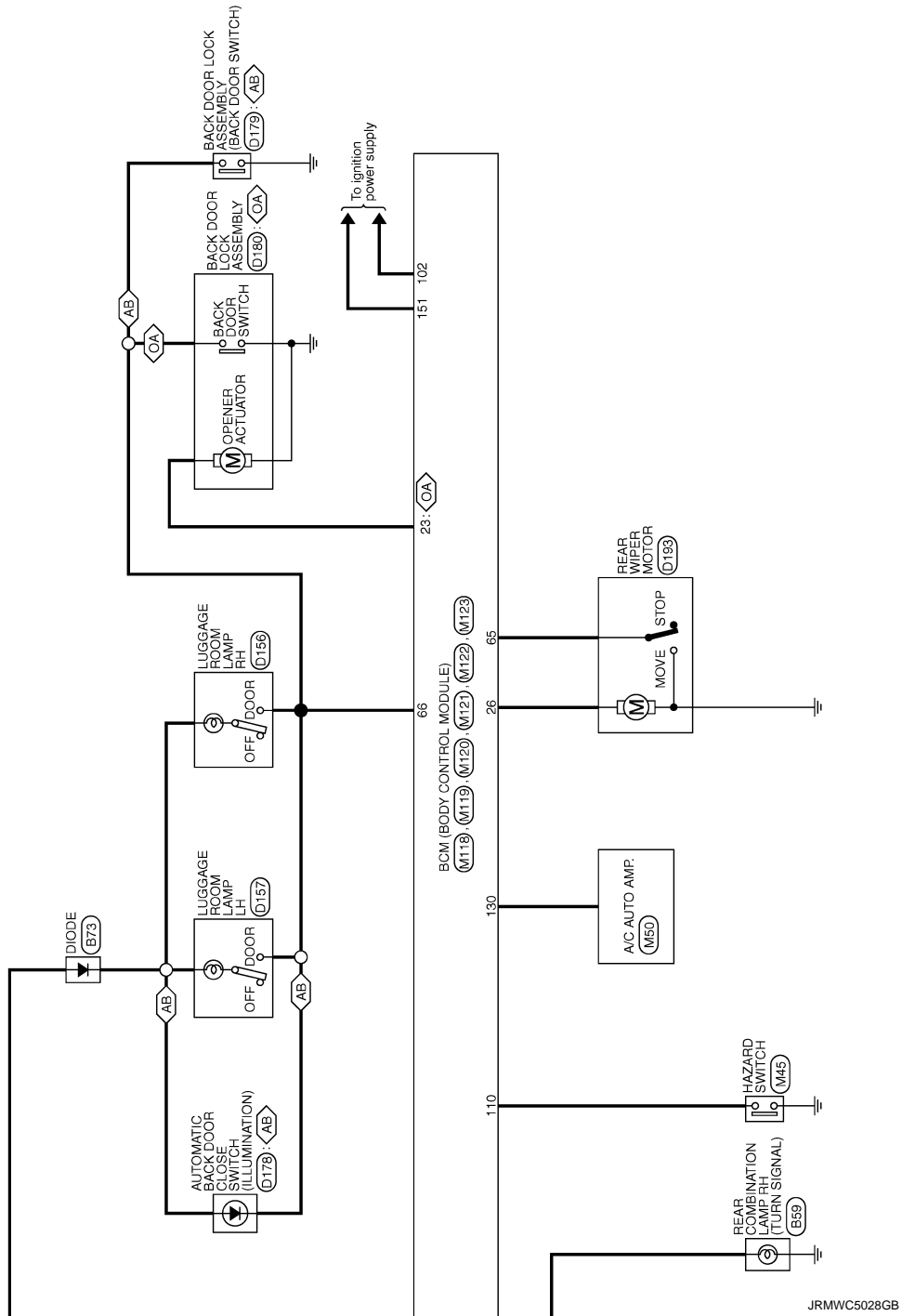

BCM (BODY CONTROL MODULE)

< ECU DIAGNOSIS INFORMATION >

BCM (BODY CONTROL MODULE)

Connector No.	B8
Connector Name	AUTOMATIC BACK DOOR CONTROL UNIT
Connector Type	TH20FW-TB8

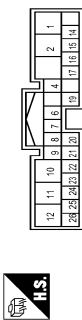

Terminal No.	Color Of Wire	Signal Name [Specification]
1	BR	BUZZER
2	Y	ABS CLOSE SW
3	Y	ABS CLOSE SW
4	L	CAN-H
5	P	CAN-L
6	LG	HALF LATCH SW
7	GR	IGN
8	SB	BAT
9	R	CLOSURE MTR (CLOSE)
10	V	CLOSURE MTR (OPEN)
11	R	TOUCH SENS LH
12	V	TOUCH SENS RH
13	W	TOUCH SENS GND
14	W	TOUCH SENS RH
15	W	TOUCH SENS LH
16	W	TOUCH SENS GND
17	LG	MAIN SW
18	P	CLOSE SW
19	B	GROUND
20	B	GROUND
21	B	GROUND
22	B	GROUND
23	GR	GROUND
24	BR	ENCODER B
25	Y	ENCODER A
26	G	ENCODER PWR



Connector No.	B51
Connector Name	REAR DOOR SWITCH LH
Connector Type	TH64FW-NH



Terminal No.	Color Of Wire	Signal Name [Specification]
3	BR	-

Connector No.	B32
Connector Name	FRONT DOOR SWITCH (DRIVER SIDE)
Connector Type	TH64FW-NH

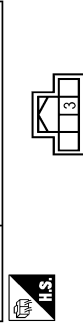

Terminal No.	Color Of Wire	Signal Name [Specification]
3	SB	-

Connector No.	B59
Connector Name	REAR COMBINATION LAMP RH
Connector Type	NS6AMW-CS

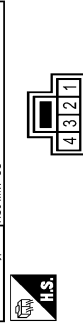

Terminal No.	Color Of Wire	Signal Name [Specification]
1	BL	[Without rear view camera] - [With rear view camera]
2	LG	- [With rear view camera]
3	BR	-
4	P	-
5	L	-

Connector No.	B72
Connector Name	DIODE
Connector Type	24335-C9802

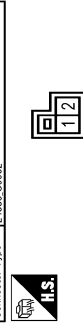

Terminal No.	Color Of Wire	Signal Name [Specification]
1	W	-
2	L	-

Connector No.	B60
Connector Name	REAR COMBINATION LAMP LH
Connector Type	NS6AMW-CS

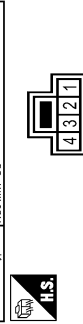

Terminal No.	Color Of Wire	Signal Name [Specification]
1	B	-
2	P	-
3	L	-
4	L	-

Connector No.	B85
Connector Name	OUTSIDE KEY ANTENNA (REAR BUMPER)
Connector Type	RK02FCY

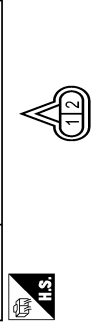

Terminal No.	Color Of Wire	Signal Name [Specification]
1	R	-
2	G	-

Connector No.	B88
Connector Name	INSIDE KEY ANTENNA (LUGGAGE ROOM)
Connector Type	RK02FCY



Terminal No.	Color Of Wire	Signal Name [Specification]
1	W	-
2	B	-

A
B
C
D
E
F
G
H
I
J
K
L
N
O
P

BCS

JRMWE5830GB

BCM (BODY CONTROL MODULE)

< ECU DIAGNOSIS INFORMATION >

BCM (BODY CONTROL MODULE)

Connector No.	B232
Connector Name	REAR DOOR SWITCH RH
Connector Type	THREW-NH



Terminal No.	Color Of Wire	Signal Name [Specification]
3	W	-

Connector No.	B233
Connector Name	FRONT DOOR SWITCH (PASSENGER SIDE)
Connector Type	THREW-NH



Terminal No.	Color Of Wire	Signal Name [Specification]
3	R	-

Connector No.	B407
Connector Name	LUMBAR SUPPORT SWITCH
Connector Type	NSDFBR-CS

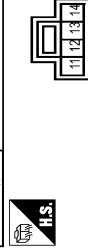

Terminal No.	Color Of Wire	Signal Name [Specification]
11	O	-
12	LG	-
13	Y/W	-
14	Y	-

Connector No.	B414
Connector Name	POWER SEAT SWITCH (DRIVER SIDE)
Connector Type	NSDFW-CS



Terminal No.	Color Of Wire	Signal Name [Specification]
1	R	-
2	B	-
3	G	-
4	G/R	-
5	V	-
6	P/L	-
7	L/W	-
8	L/R	-
10	L/B	-

Connector No.	B434
Connector Name	POWER SEAT SWITCH (PASSENGER SIDE)
Connector Type	NSDFW-CS

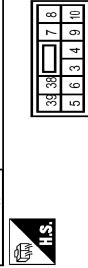

Terminal No.	Color Of Wire	Signal Name [Specification]
1	R	-
2	B	-
3	G	-
4	G/R	-
5	V	-
6	R/L	-

Connector No.	B452
Connector Name	DRIVER SEAT CONTROL UNIT
Connector Type	TH2FPW



Terminal No.	Color Of Wire	Signal Name [Specification]
11	G/B	-
12	G/W	-
13	R/G	-
14	W/B	-
15	V/B	-
17	LG/B	-
18	LG/R	-
19	G/Y	-
20	R/Y	-
21	L/Y	-
22	BR/Y	-
23	P	-
24	P/L	-
25	G/O	-
26	L/O	-
27	V	-
28	W/W	-
29	GR	-
31	BR/W	-
32	W/L	-
33	W	-

Connector No.	D5
Connector Name	POWER WINDOW MAIN SWITCH
Connector Type	NSDFW-CS

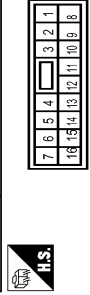

Terminal No.	Color Of Wire	Signal Name [Specification]
2	GR	-
3	W	-
3	BR	-
4	L	-
5	SB	-
6	R	-
7	P	-
8	L	-
9	G	-
10	V	-
11	LG	-
13	Y	-
14	O	-
15	R	-

Connector No.	D6
Connector Name	POWER WINDOW MAIN SWITCH
Connector Type	NSDFW-CS



Terminal No.	Color Of Wire	Signal Name [Specification]
17	B	-
19	LG	-

JRMWE5831GB

BCM (BODY CONTROL MODULE)

< ECU DIAGNOSIS INFORMATION >

BCM (BODY CONTROL MODULE)

Connector No.	D9
Connector Name	FRONT DOOR LOCK ASSEMBLY (DRIVER SIDE)
Connector Type	EBEGY-RS



Terminal No.	Color Of Wire	Signal Name [Specification]
1	V	-
2	G	-
3	B	-
4	B	-
5	R	-
6	L	-

Connector No.	D11
Connector Name	FRONT OUTSIDE HANDLE LH (REQUEST SWITCH)
Connector Type	RH02FB



Terminal No.	Color Of Wire	Signal Name [Specification]
1	W	-
2	B	-

Connector No.	D12
Connector Name	FRONT OUTSIDE HANDLE LH (OUTSIDE KEY ANTENNA)
Connector Type	RH02MGY



Terminal No.	Color Of Wire	Signal Name [Specification]
1	P	-
2	V	-

Connector No.	D17
Connector Name	STEP LAMP (DRIVER SIDE)
Connector Type	CO2FW



Terminal No.	Color Of Wire	Signal Name [Specification]
1	G	-
2	R	-

Connector No.	D45
Connector Name	FRONT POWER WINDOW SWITCH (PASSENGER SIDE)
Connector Type	HS16FN-CS

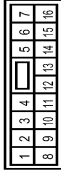

Terminal No.	Color Of Wire	Signal Name [Specification]
3	W	-
4	R	-
8	R	-
9	LS	-
10	P	-
11	B	-
12	Y	-
15	G	-
16	O	-

Connector No.	D48
Connector Name	FRONT DOOR LOCK ASSEMBLY (PASSENGER SIDE)
Connector Type	EBEGY-RS

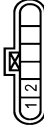

Terminal No.	Color Of Wire	Signal Name [Specification]
5	V	-
6	G	-

Connector No.	D50
Connector Name	FRONT OUTSIDE HANDLE RH (REQUEST SWITCH)
Connector Type	RH02EB



Terminal No.	Color Of Wire	Signal Name [Specification]
1	O	-
2	B	-

Connector No.	D51
Connector Name	STEP LAMP (PASSENGER SIDE)
Connector Type	CO2FW



Terminal No.	Color Of Wire	Signal Name [Specification]
1	G	-
2	R	-

A
B
C
D
E
F
G
H
I
J
K
L
N
O
P

BCS

JRMWE5832GB

BCM (BODY CONTROL MODULE)

< ECU DIAGNOSIS INFORMATION >

BCM (BODY CONTROL MODULE)

Connector No.	D82
Connector Name	FRONT OUTSIDE HANDLE RH (OUTSIDE KEY ANTENNA)
Connector Type	RK02M3Y



Terminal No.	Color Of Wire	Signal Name [Specification]
1	LG	--
2	W	--

Connector No.	D83
Connector Name	REAR POWER WINDOW SWITCH LH
Connector Type	NS08FW-CS



Terminal No.	Color Of Wire	Signal Name [Specification]
1	R	--
2	P	--
3	SB	--
4	LG	--
5	L	--

Connector No.	D85
Connector Name	REAR DOOR LOCK ASSEMBLY LH
Connector Type	EB0EY-RS



Terminal No.	Color Of Wire	Signal Name [Specification]
2	G	--

Connector No.	D103
Connector Name	REAR POWER WINDOW SWITCH RH
Connector Type	NS08FW-CS

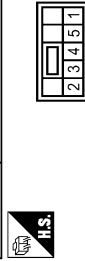

Terminal No.	Color Of Wire	Signal Name [Specification]
1	R	--
2	P	--
3	SB	--
4	LG	--
5	L	--

Connector No.	D105
Connector Name	REAR DOOR LOCK ASSEMBLY RH
Connector Type	EB0EY-RS



Terminal No.	Color Of Wire	Signal Name [Specification]
3	G	--

Connector No.	D155
Connector Name	LUGGAGE ROOM LAMP RH
Connector Type	CJ0FW



Terminal No.	Color Of Wire	Signal Name [Specification]
2	W	--
4	LG	--

Connector No.	D157
Connector Name	LUGGAGE ROOM LAMP LH
Connector Type	CJ0HEW



Terminal No.	Color Of Wire	Signal Name [Specification]
2	W	--
4	LG	--

Connector No.	D178
Connector Name	AUTOMATIC BACK DOOR CLOSE SWITCH
Connector Type	TK0BEFY



Terminal No.	Color Of Wire	Signal Name [Specification]
1	O	--
2	B	--
3	W	--
4	LG	--

JRMWE5833GB

BCM (BODY CONTROL MODULE)

< ECU DIAGNOSIS INFORMATION >

BCM (BODY CONTROL MODULE)

Connector No.	D179
Connector Name	BACK DOOR LOCK ASSEMBLY
Connector Type	NSDFW-CS



Terminal No.	Color Of Wire	Signal Name [Specification]
1	R	-
2	V	-
3	G	-
4	L	-
5	L	-
6	W	-
7	LG	-
8	B	-

Connector No.	D180
Connector Name	BACK DOOR LOCK ASSEMBLY
Connector Type	NSDFW-CS



Terminal No.	Color Of Wire	Signal Name [Specification]
1	BR	-
2	B	-
3	LG	-
4	B	-

Connector No.	D188
Connector Name	BACK DOOR OPENER SWITCH ASSEMBLY
Connector Type	TUG4MW-NH



Terminal No.	Color Of Wire	Signal Name [Specification]
1	W	-
2	B	-
3	B	-
4	V	-

Connector No.	D183
Connector Name	REAR WIPER MOTOR
Connector Type	CJ04H-W-1V



Terminal No.	Color Of Wire	Signal Name [Specification]
1	G	-
3	GR	-
4	O	-

Connector No.	E10
Connector Name	INTELLIGENT POWER DISTRIBUTION MODULE ENGINE ROOM
Connector Type	TH20FW-CS12-M4-1V



Terminal No.	Color Of Wire	Signal Name [Specification]
4	LG	-
7	GR	-
10	GR	-
12	B	-
13	SB	-
15	W	-
16	R	-
19	Y	-
20	L	-
21	O	-
22	SB	-
23	GR	-
24	G	-
25	GR	-
27	W	-
28	SB	-
30	BR	-
34	O	-
35	P	-
36	G	-
38	GR	-

Connector No.	E11
Connector Name	INTELLIGENT POWER DISTRIBUTION MODULE ENGINE ROOM
Connector Type	TUG5FW-NH



Terminal No.	Color Of Wire	Signal Name [Specification]
39	P	-
40	B	-
41	B	-
42	SB	-
43	Y	-
44	W	-
45	O	-
46	BR	-

Connector No.	E16
Connector Name	ECM
Connector Type	IRH20FE-R28-L-LH



Terminal No.	Color Of Wire	Signal Name [Specification]
81	W	ACCELERATOR PEDAL POSITION SENSOR 1
82	O	ACCELERATOR PEDAL POSITION SENSOR 2
83	BR	SENSOR POWER SUPPLY
84	B	SENSOR GROUND
85	B	ASCO STEERING SWITCH
87	SB	EVAP CANISTER PURGE SENSOR
88	GR	SENSOR POWER SUPPLY
88	O	DATA LINK CONNECTOR
81	L	SENSOR POWER SUPPLY
92	BR	SENSOR GROUND
93	BR	IGNITION SWITCH
94	GR	ENGINE SPEED OUTPUT SIGNAL

A
B
C
D
E
F
G
H
I
J
K
L
N
O
P

BCS

BCM (BODY CONTROL MODULE)

< ECU DIAGNOSIS INFORMATION >

BCM (BODY CONTROL MODULE)

86	Y	FUEL TANK VAPOR LEAK SENSOR
87	GR	SENSOR GROUND
87	P	CAN COMMUNICATION LINE (CAN-L)
88	L	CAN COMMUNICATION LINE (CAN-H)
100	G	SENSOR GROUND
102	R	PNP SIGNAL
104	SB	SENSOR GROUND
105	V	POWER SUPPLY FOR ECM
106	SB	STOP LAMP SWITCH
107	B	ECM GROUND
108	B	ECM GROUND
109	W	EVAP CANISTER VENT CONTROL VALVE
110	G	ASSED BRAKE SWITCH
111	B	ECM GROUND
112	B	ECM GROUND

Connector No.	E25
Connector Name	INTELLIGENT KEY WARNING BUZZER
Connector Type	RK03FBR



Terminal No.	1	3	GR
Color Of Wire	G	GR	
Signal Name [Specification]			

Connector No.	E36
Connector Name	ABS ACTUATOR AND ELECTRIC UNIT (CONTROL UNIT)
Connector Type	AE22FB-AJ24-LH

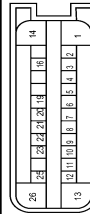

Terminal No.	1	R	VALVE / ECU SUPPLY
Color Of Wire	R		
Signal Name [Specification]			
2	Y	WSS RL PWR (+)	
3	L	WSS RL SIG (-)	
4	GR	CLUSTER SUPPLY	
5	B	WSS FR PWR (+)	
6	W	WSS FR SIG (-)	
7	LG	LIS	
8	V	WSS FL SIG (-)	
9	W	WSS FL PWR (+)	
10	SB	CLUSTER GND	
11	P	WSS RR PWR (+)	
12	P	WSS RR SIG (-)	
13	GR	ECU GROUND	
14	GW	MOTORS SUPPLY	
15	SB	ELIS	
16	BR	CAN 2 H	
18	BR	IGN	
20	GR	CAN 1 L	
21	P	CAN 1 L	
22	Y	VDC OFF SW	
23	L	CAN 1 H	
25	W	CAN 2 L	
26	B/W	VALVE / ECU GND	

Connector No.	E103
Connector Name	FUSE BLOCK (J/B)
Connector Type	NS16FW-CS

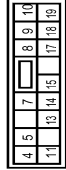

Terminal No.	11F	G	
Color Of Wire	G		
Signal Name [Specification]			
12F	V		
2F	LG		
4F	BR		
8F	Y		
9F	R		
9F	GR		

Connector No.	E116
Connector Name	STOP LAMP SWITCH
Connector Type	MR0EW-LC



Terminal No.	1	Y	
Color Of Wire	Y		
Signal Name [Specification]			
2	LG		
3	G		
4	Y		

Connector No.	E318
Connector Name	FRONT COMBINATION LAMP LH
Connector Type	Z05FBR



Terminal No.	1	LG	
Color Of Wire	LG		
Signal Name [Specification]			
2	B		
3	Y		

Connector No.	E319
Connector Name	FRONT COMBINATION LAMP RH
Connector Type	Z03FBR



Terminal No.	1	Y	
Color Of Wire	Y		
Signal Name [Specification]			
2	R		
3	B		
3	G		

Connector No.	E327
Connector Name	FRONT TURN SIGNAL LAMP LH
Connector Type	RS02FCY



Terminal No.	1	Y	
Color Of Wire	Y		
Signal Name [Specification]			
2	B		

BCM (BODY CONTROL MODULE)

< ECU DIAGNOSIS INFORMATION >

BCM (BODY CONTROL MODULE)

Connector No.	E228
Connector Name	FRONT TURN SIGNAL LAMP RH
Connector Type	HSREQCY



Terminal No.	Color Of Wire	Signal Name [Specification]
1	G	-
2	B	-

Connector No.	F12
Connector Name	FRAME R INTELLIGENT POWER DISTRIBUTION MODULE ENGINE ROOM
Connector Type	THZBFW-CS1Z-M4



Terminal No.	Color Of Wire	Signal Name [Specification]
48	W	-
49	R/B	-
51	LG	-
52	Y/G	-
53	R/W	-
54	G/W	-
55	W/L	-
56	R/Y	-
57	O	-
58	Y	-
59	W/B	-
62	R/B	-
75	LG	-
76	SB	-
77	GR	-
80	B	-

Connector No.	F23
Connector Name	TOM (TRANSMISSION CONTROL MODULE)
Connector Type	RH40FB-E23-L-RH



Terminal No.	Color Of Wire	Signal Name [Specification]
1	P/B	TRANSMISSION RANGE SWITCH 2
2	P/B	TRANSMISSION RANGE SWITCH 2
3	G/D	TRANSMISSION RANGE SWITCH 3
4	GR	TRANSMISSION RANGE SWITCH 3 (MONITOR)
5	B	GROUND
7	W	SENSOR GROUND
8	G/W	CLOCK (SEL 2)
9	L/R	CHP SELECT (SEL 1)
10	BR/R	DATA I/O (SEL 3)
11	BR/W	TRANSMISSION RANGE SWITCH 1
13	V	O/V FLUID TEMPERATURE SENSOR
14	R/W	PRIMARY PRESSURE SENSOR
15	V/W	SECONDARY PRESSURE SENSOR
19	G/B	REVERSE LAMP-RELAY
20	R/B	STARTER RELAY
21	Y/B	SENSOR POWER
26	Y/A	SENSOR POWER
27	R/G	STEP MOTOR D
28	R	STEP MOTOR C
29	O/B	STEP MOTOR B
30	G/R	STEP MOTOR A
31	P	CAN-H
32	L	CAN-L
33	LG	PRIMARY SPEED SENSOR
34	LG/R	SECONDARY SPEED SENSOR
37	V/R	LOCK-UP SELECT SOLENOID VALVE
38	L/W	TORQUE CONVERTER CLUTCH SOLENOID VALVE
39	W/B	SECONDARY PRESSURE SOLENOID VALVE
40	R/Y	LINE PRESSURE SOLENOID VALVE
42	Y	POWER SUPPLY
47	L/R	POWER SUPPLY (MEMORY BACK-UP)
48	Y	POWER SUPPLY

Connector No.	M1
Connector Name	FUSE BLOCK (J/B)
Connector Type	NSBFW-M2



Terminal No.	Color Of Wire	Signal Name [Specification]
1A	Y	-
2A	Y	-
3A	Y	-
4A	GR	-
7A	LG	-
8A	Y	-

Connector No.	M2
Connector Name	FUSE BLOCK (J/B)
Connector Type	NS10FW-CS

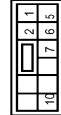

Terminal No.	Color Of Wire	Signal Name [Specification]
1B	W	-
3B	L	-
4B	G	-
5B	L	-
6B	Y	-
7B	R	-
8B	R	-
9B	GR	-

Connector No.	M3
Connector Name	FUSE BLOCK (J/B)
Connector Type	NS12FW-CS

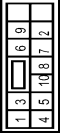

Terminal No.	Color Of Wire	Signal Name [Specification]
10C	SB	-
11C	R	-
12C	G	-
6C	BR	-
7C	B	-
8C	G	-
9C	GR	-

Connector No.	M4
Connector Name	DATA LINK CONNECTOR
Connector Type	BD1BFW



Terminal No.	Color Of Wire	Signal Name [Specification]
3	LG	-
4	B	-
5	B	-
6	L	-
7	BR	-
8	G	-
11	L	-
14	SB	-
16	Y	-

A
B
C
D
E
F
G
H
I
J
K
L
N
O
P



BCM (BODY CONTROL MODULE)

< ECU DIAGNOSIS INFORMATION >

BCM (BODY CONTROL MODULE)

Connector No.	M17
Connector Name	OPTICAL SENSOR
Connector Type	TK09W



Terminal No.	Color	Wire	Signal Name [Specification]
1	Y	Y	-
2	Y	Y	-
3	P	P	-

Connector No.	M21
Connector Name	TIRE PRESSURE RECEIVER
Connector Type	TK09W

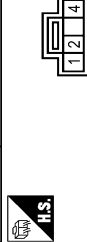

Terminal No.	Color	Wire	Signal Name [Specification]
1	P	P	GROUND
2	O	O	SIGNAL
4	V	V	POWER

Connector No.	M34
Connector Name	COMBINATION METER
Connector Type	TH40FW-NH

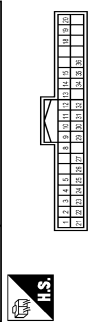

Terminal No.	Color	Wire	Signal Name [Specification]
1	G	G	BATTERY POWER SUPPLY
2	LG	LG	IGN SIGNAL
3	B	B	GROUND
4	B	B	GROUND
5	SB	SB	ILLUMINATION CONTROL SIGNAL
8	SB	SB	TRIP RESET SIGNAL
9	W	W	SW ILL POWER
10	LG	LG	METER CONTROL SWITCH GROUND
11	L	L	ENTER SWITCH SIGNAL
12	R	R	SELECT SWITCH SIGNAL
13	V	V	ILLUMINATION CONTROL SWITCH SIGNAL (2-PULSE)
14	GR	GR	ILLUMINATION CONTROL SWITCH SIGNAL (3)
15	BR	BR	AIR BAG SIGNAL
16	G	G	AMBIENT SENSOR SIGNAL
17	Y	Y	AMBIENT SENSOR SIGNAL
20	Y	Y	AMBIENT SENSOR GROUND
21	L	L	CAN-H
22	P	P	CAN-L
23	B	B	GROUND
24	W	W	FUEL LEVEL SENSOR GROUND
25	BR	BR	ALTERNATOR SIGNAL
26	G	G	PARKING BRAKE SWITCH SIGNAL
27	V	V	WASHER FLUID LEVEL SWITCH SIGNAL
28	R	R	WASHER LEVEL SWITCH SIGNAL
30	P	P	VEHICLE SPEED SIGNAL (2-PULSE)
31	V	V	VEHICLE SPEED SIGNAL (3-PULSE)
32	LG	LG	OVERDRIVE CONTROL SWITCH SIGNAL
34	G	G	FUEL LEVEL SENSOR SIGNAL
35	B	B	SEAT BELT BUZZER CONTROL SWITCH SIGNAL
36	R	R	SEAT BELT BUZZER CONTROL SWITCH SIGNAL (PASSER'S SEAT)

Connector No.	M35
Connector Name	HAZARD SWITCH
Connector Type	TK09W

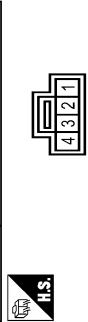

Terminal No.	Color	Wire	Signal Name [Specification]
1	G	G	-
2	G	G	-
3	B	B	-
4	B/Y	B/Y	-

Connector No.	M50
Connector Name	A/C AUTO AMP
Connector Type	SA840FW



Terminal No.	Color	Wire	Signal Name [Specification]
1	L	L	CAN-H
2	P	P	CAN-L
6	L	L	TX AMP SW & DISP
7	P	P	RX (SW AMP)
10	G	G	LAMP SIG (Without colour display)
10	L	L	LAMP SIG (With colour display)
11	R	R	WACTR
15	BR	BR	SUN SENS
16	GR	GR	INTAKE SENS (Without colour display)
18	GR	GR	INTAKE SENS (With colour display)
19	B	B	IGN
20	G	G	GROUND
26	GR	GR	RR DEF F/B
27	BR	BR	RR DEF ON
32	L	L	FAN PWM
34	P	P	AMB POWER (With colour display)

34	Y	Y	AMB POWER (Without colour display)
35	G	G	AMB SENS (Without colour display)
35	L	L	AMB SENS (With colour display)
36	LG	LG	INCAR SENS
37	SB	SB	SENS GND (Without colour display)
37	Y	Y	SENS GND (With colour display)
39	B	B	GND (POWER)
40	Y	Y	BAT

Connector No.	M57
Connector Name	CVT SHIFT SELECTOR
Connector Type	TK10PW

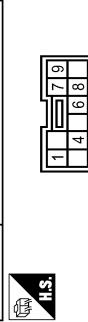

Terminal No.	Color	Wire	Signal Name [Specification]
1	LG	LG	-
4	B	B	-
6	P	P	-
7	B	B	-
8	Y	Y	-

Connector No.	M78
Connector Name	REMOTE KEYLESS ENTRY RECEIVER
Connector Type	JAB04FB

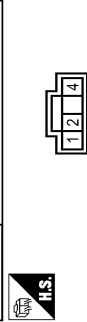

Terminal No.	Color	Wire	Signal Name [Specification]
1	P	P	GROUND
2	P	P	SIGNAL
4	L	L	+12V

BCM (BODY CONTROL MODULE)

< ECU DIAGNOSIS INFORMATION >

BCM (BODY CONTROL MODULE)

Connector No.	M189
Connector Name	KEY SLOT
Connector Type	TH18FW-NH

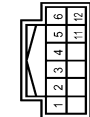

Terminal No.	Color Of Wire	Signal Name [Specification]
1	GR	BAT
2	GB	CLCK
3	GR	CLAT
4	GR	ILLBAT
5	R	ILL
6	R	GROUND
7	B	KEY SWITCH SIGNAL
11	Y	

Connector No.	M100
Connector Name	SECURITY INDICATOR LAMP
Connector Type	TR02FBR



Terminal No.	Color Of Wire	Signal Name [Specification]
1	GR	
2	O	

Connector No.	M101
Connector Name	PUSH-BUTTON IGNITION SWITCH
Connector Type	TK08FBR

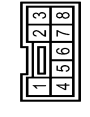

Terminal No.	Color Of Wire	Signal Name [Specification]
1	B	
2	W	
3	W	
4	BR	
5	R	
6	L	
7	P	
8	GR	

Connector No.	M103
Connector Name	COMBINATION SWITCH
Connector Type	TH18FW-NH

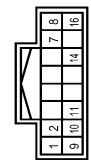

Terminal No.	Color Of Wire	Signal Name [Specification]
1	G	
2	Y	OUTPUT 4
3	BG	FR
4	W	IGN
5	W	OUTPUT 3
6	GR	GROUND
7	GR	OUTPUT 3
8	L	OUTPUT 5
9	SB	INPUT 2
10	P	INPUT 4
11	O	INPUT 1
12	W	OUTPUT 1

13	R	INPUT 5
14	P	OUTPUT 2



Terminal No.	Color Of Wire	Signal Name [Specification]
1	W	BAT (E/L)
2	GR	POWER WINDOW POWER SUPPLY (BAT)
3	L	POWER WINDOW POWER SUPPLY (IGN)

Connector No.	M119
Connector Name	BCM (BODY CONTROL MODULE)
Connector Type	INS16FW-CS

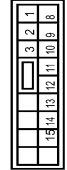

Terminal No.	Color Of Wire	Signal Name [Specification]
4	P/W	INTERIOR ROOM LAMP POWER SUPPLY
5	G	PASSENGER DOOR UNLOCK OUTPUT
7	W	STEP LAMP CONT
8	V	ALL DOOR FUEL LID LOCK OUTPUT
9	G	DRIVER DOOR FUEL LID UNLOCK OUTPUT
10	L	REAR DOOR UNLOCK OUTPUT
11	CS	GROUND
13	B	GROUND
14	O	PUSH-BUTTON IGNITION SW ILL GND
15	L	ACC IND
17	G	TURN SIGNAL RH
18	BR	TURN SIGNAL LH
19	Y	INT ROOM LAMP CONT

Connector No.	M120
Connector Name	BCM (BODY CONTROL MODULE)
Connector Type	INS16FW-CS

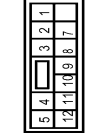

Terminal No.	Color Of Wire	Signal Name [Specification]
23	BR	BACK DOOR OPEN OUTPUT
29	G	REAR WIPER OUTPUT

Connector No.	M121
Connector Name	BCM (BODY CONTROL MODULE)
Connector Type	TH48FCY-NH

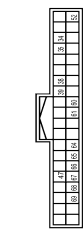

Terminal No.	Color Of Wire	Signal Name [Specification]
34	B	LUGGAGE ROOM ANT-
35	W	LUGGAGE ROOM ANT+
38	L	REAR BUMPER ANT-
39	BR	REAR BUMPER ANT+
47	L	IGN RELAY (PDM E/R) CONT
52	R	STARTER RELAY CONT
60	BR	PUSH SW
61	R	BACK DOOR OPENER REQUEST SW
65	O	REAR WIPER STOP POSITION
66	Y	BACK DOOR SW
67	L	BACK DOOR SW
68	W	REAR LH DOOR SW
69	R	REAR RH DOOR SW

JRMWE5838GB

A
B
C
D
E
F
G
H
I
J
K
L
BCS
N
O
P

BCM (BODY CONTROL MODULE)

< ECU DIAGNOSIS INFORMATION >

BCM (BODY CONTROL MODULE)

Connector No.	M122
Connector Name	BCM (BODY CONTROL MODULE)
Connector Type	TH48PB-NH



Terminal No.	Wire	Color	Signal Name [Specification]
72	B		ECOM ANT-
73	W		ECOM ANT+
74	Y		PASSENGER DOOR ANT-
75	LG		PASSENGER DOOR ANT+
76	V		DRIVER DOOR ANT-
77	P		DRIVER DOOR ANT+
80	SB		NATS ANT AMP
81	O		NATS ANT AMP
82	BR		IGN RELAY (F/B) CONT
83	P		KEYLESS ENTRY RECEIVER COMM
87	R		COMBI SW INPUT 5
88	GR		COMBI SW INPUT 3
90	P		CAN-L
91	L		CAN-H
92	B		IGN IND
93	P		ACC-RELAY CONT
95	L		CVT SHIFT SELECTOR POWER SUPPLY
99	V		SHIFT P
100	P		PASSENGER DOOR REQUEST SW
101	W		DRIVER DOOR REQUEST SW
102	Y		BLOWER RELAY CONT
103	L		KEYLESS ENTRY RECEIVER POWER SUPPLY
107	O		COMBI SW INPUT 1
108	P		COMBI SW INPUT 4
109	SB		COMBI SW INPUT 2
110	G		HAZARD SW

Connector No.	M123
Connector Name	BCM (BODY CONTROL MODULE)
Connector Type	TH48FG-NH

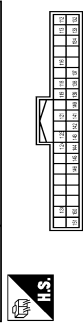

Terminal No.	Wire	Color	Signal Name [Specification]
112	P/B		RAIN SENSOR SERIAL LINK
113	GR		OFF-GAS SENSOR
116	GR		STOP LAMP SW 1
118	L		STOP LAMP SW 2
119	W		DR DOOR UNLOCK SENSOR
121	Y		KEY SLOT SW
123	G		IGN F/B
124	R		PASSENGER DOOR SW
130	BR		REAR DEFOGGER SW
132	G		POWER WINDOW SW COMM
133	W		PUSH-BUTTON IGNITION SW ILL POWER
134	R		LOCK IND
137	P		RECEIVER SENSOR GND
138	O		RECEIVER SENSOR POWER SUPPLY
140	GR		TIRE PRESSURE SENSOR COMM
142	O		SECURITY IND LAMP CONT
143	W		COMBI SW OUTPUT 1
144	P		COMBI SW OUTPUT 2
145	V		COMBI SW OUTPUT 3
146	Y		COMBI SW OUTPUT 4
150	SB		DRIVER DOOR SW
151	G		REAR WINDOW DEFOGGER RELAY CONT

Connector No.	M174
Connector Name	AV CONTROL UNIT
Connector Type	TH32FW-NH

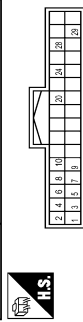

Terminal No.	Wire	Color	Signal Name [Specification]
75	LG		AV COMM (L)
77	SB		AV COMM (H)
78	LG		AV COMM (L)
79	SB		AV COMM (H)
80	P		CAN-L
81	L		CAN-H
82	V		SW GND
85	L		SHIELD
87	R		TEL VOICE SIGNAL (-)
88	L		TEL VOICE SIGNAL (+)
92	V		VEHICLE SPEED SIGNAL (8-PULSE)
93	G		PARKING BRAKE (Without EDS system)
94	SB		REVERSE
95	G		IGNITION
102	W		REVERSE
103	B		AVX SOUND SIGNAL LH (+)
104	R		AVX SOUND SIGNAL RH (-)



Connector No.	M262
Connector Name	INSIDE KEY ANTENNA (CONSOLE)
Connector Type	IR02PGY

Terminal No.	Wire	Color	Signal Name [Specification]
65	LG		PARKING BRAKE
67	LG		-
68	LG		-
71	SHIELD		SHIELD
72	B		MICROPHONE VCC
73	R		COMM (CONT- DISP)
74	P		CAN-L
75	LG		AV COMM (L)
76	LG		AV COMM (L)
79	R		ILLUMINATION SIGNAL
80	G		IGNITION
81	SB		REVERSE
82	V		VEHICLE SPEED SIGNAL (8-PULSE)
87	W		MICROPHONE SIGNAL
88	B		-
89	W		-
90	L		CAN-H
91	SB		AV COMM (H)
92	SB		AV COMM (H)

Connector No.	M180
Connector Name	AV CONTROL UNIT
Connector Type	TH32FW-NH

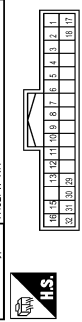

Terminal No.	Wire	Color	Signal Name [Specification]
1	W		-
2	B		-

JRMWE5839GB

BCM (BODY CONTROL MODULE)

< ECU DIAGNOSIS INFORMATION >

BCM (BODY CONTROL MODULE)

Connector No.	R18
Connector Name	VANITY MIRROR LAMP (PASSENGER SIDE)
Connector Type	MCA02FW



Terminal No.	Color Of Wire	Signal Name [Specification]
1	B	-
2	P/W	-

Connector No.	R19
Connector Name	MAP LAMP
Connector Type	TK0BEGY



Terminal No.	Color Of Wire	Signal Name [Specification]
1	P/W	-
2	Y	-
3	B	-
4	SB	-
5	R/Y	-
6	R/L	-

Connector No.	R21
Connector Name	PERSONAL LAMP
Connector Type	TH04FW-NH



Terminal No.	Color Of Wire	Signal Name [Specification]
1	P/W	-
2	SB	-
3	SB	-

Connector No.	R23
Connector Name	RAIN SENSOR
Connector Type	JA0303E



Terminal No.	Color Of Wire	Signal Name [Specification]
1	Y/R	-
2	R	-
3	B	-

Connector No.	R24
Connector Name	VANITY MIRROR LAMP (DRIVER SIDE)
Connector Type	MCA02FW



Terminal No.	Color Of Wire	Signal Name [Specification]
1	B	-
2	P/W	-

Connector No.	R101
Connector Name	SUNROOF MOTOR ASSEMBLY
Connector Type	YEARDFGY

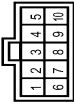

Terminal No.	Color Of Wire	Signal Name [Specification]
1	B	GROUND
2	O	GROUND
3	L	IGN
4	Y	PUSH SW
5	LG	OPEN SW
6	R	BAT
7	P	COMM
8	BR	VEHICLE SPEED (2-PULSE)
9	W	2ND SW
10	V	CLOSE SW

Connector No.	R102
Connector Name	SUNSHADE MOTOR ASSEMBLY
Connector Type	YEARDFGY

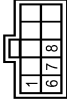

Terminal No.	Color Of Wire	Signal Name [Specification]
1	B	GROUND
6	D	COMM
7	D	VEHICLE SPEED (2-PULSE)
8	BR	VEHICLE SPEED (2-PULSE)

Fail-safe

FAIL-SAFE CONTROL BY DTC

BCM performs fail-safe control when any DTC are detected.

JRMWE5840GB

INFOID:000000009722474

A
B
C
D
E
F
G
H
I
J
K
L
N
O
P

BCS

BCM (BODY CONTROL MODULE)

< ECU DIAGNOSIS INFORMATION >

Display contents of CONSULT	Fail-safe	Cancellation
B2190: NATS ANTENNA AMP	Inhibit engine cranking	Erase DTC
B2191: DIFFERENCE OF KEY	Inhibit engine cranking	Erase DTC
B2192: ID DISCORD BCM-ECM	Inhibit engine cranking	Erase DTC
B2193: CHAIN OF BCM-ECM	Inhibit engine cranking	Erase DTC
B2195: ANTI SCANNING	Inhibit engine cranking	Ignition switch ON → OFF
B2560: STARTER CONT RELAY	Inhibit engine cranking	500 ms after the following CAN signal communication status becomes consistent <ul style="list-style-type: none"> • Starter control relay signal • Starter relay status signal
B2608: STARTER RELAY	Inhibit engine cranking	500 ms after the following signal communication status becomes consistent <ul style="list-style-type: none"> • Starter motor relay control signal • Starter relay status signal (CAN)
B260A: IGNITION RELAY	Inhibit engine cranking	500 ms after the following conditions are fulfilled <ul style="list-style-type: none"> • IGN relay (IPDM E/R) control signal: OFF (Battery voltage) • Ignition ON signal (CAN to IPDM E/R): OFF (Request signal) • Ignition ON signal (CAN from IPDM E/R): OFF (Condition signal)
B260F: ENG STATE SIG LOST	Maintains the power supply position attained at the time of DTC detection	When any of the following conditions are fulfilled <ul style="list-style-type: none"> • Power position changes to ACC • Receives engine status signal (CAN)
B2617: STARTER RELAY CIRC	Inhibit engine cranking	1 second after the starter motor relay control inside BCM becomes normal
B2618: BCM	Inhibit engine cranking	1 second after the ignition relay (IPDM E/R) control inside BCM becomes normal
B261E: VEHICLE TYPE	Inhibit engine cranking	BCM initialization

HIGH FLASHER OPERATION

BCM detects the turn signal lamp circuit status by the current value.

BCM increases the turn signal lamp blinking speed if the bulb or harness open is detected with the turn signal lamp operating.

NOTE:

The blinking speed is normal while activating the hazard warning lamp.

FAIL-SAFE CONTROL BY RAIN SENSOR MALFUNCTION

- BCM judges the rain sensor serial link error by the rain sensor serial link condition and detects the rain sensor malfunction by rain sensor malfunction signal.
- When BCM detects the rain sensor serial link error or the rain sensor malfunction while front wiper AUTO operation, BCM operates a fail-safe control.

NOTE:

If rain sensor malfunction is detected when ignition switch is turned OFF ⇒ ON and front wiper switch is INT/AUTO position, BCM operates a fail-safe control.

REAR WIPER MOTOR PROTECTION

BCM detects the rear wiper stopping position according to the rear wiper stop position signal.

When the rear wiper stop position signal does not change for more than 5 seconds while driving the rear wiper, BCM stops power supply to protect the rear wiper motor.

Condition of cancellation

1. More than 1 minute is passed after the rear wiper stop.
2. Turn rear wiper switch OFF.
3. Operate the rear wiper switch or rear washer switch.

DTC Inspection Priority Chart

INFOID:000000009722475

If some DTCs are displayed at the same time, perform inspections one by one based on the following priority chart.

BCM (BODY CONTROL MODULE)

< ECU DIAGNOSIS INFORMATION >

Priority	DTC	
1	B2562: LOW VOLTAGE	A
2	<ul style="list-style-type: none"> • U1000: CAN COMM • U1010: CONTROL UNIT(CAN) 	B
3	<ul style="list-style-type: none"> • B2190: NATS ANTENNA AMP • B2191: DIFFERENCE OF KEY • B2192: ID DISCORD BCM-ECM • B2193: CHAIN OF BCM-ECM • B2195: ANTI SCANNING 	C
4	<ul style="list-style-type: none"> • B2553: IGNITION RELAY • B2555: STOP LAMP • B2556: PUSH-BTN IGN SW • B2557: VEHICLE SPEED • B2560: STARTER CONT RELAY • B2601: SHIFT POSITION • B2602: SHIFT POSITION • B2603: SHIFT POSI STATUS • B2604: PNP SW • B2605: PNP SW • B2608: STARTER RELAY • B260A: IGNITION RELAY • B260F: ENG STATE SIG LOST • B2614: ACC RELAY CIRC • B2615: BLOWER RELAY CIRC • B2616: IGN RELAY CIRC • B2617: STARTER RELAY CIRC • B2618: BCM • B261A: PUSH-BTN IGN SW • B261E: VEHICLE TYPE • B26EA: KEY REGISTRATION • C1729: VHCL SPEED SIG ERR • U0415: VEHICLE SPEED SIG 	D E F G H I
	<ul style="list-style-type: none"> • C1704: LOW PRESSURE FL • C1705: LOW PRESSURE FR • C1706: LOW PRESSURE RR • C1707: LOW PRESSURE RL • C1708: [NO DATA] FL • C1709: [NO DATA] FR • C1710: [NO DATA] RR • C1711: [NO DATA] RL • C1716: [PRESSDATA ERR] FL • C1717: [PRESSDATA ERR] FR • C1718: [PRESSDATA ERR] RR • C1719: [PRESSDATA ERR] RL • C1734: CONTROL UNIT 	J K L
6	<ul style="list-style-type: none"> • B2622: INSIDE ANTENNA • B2623: INSIDE ANTENNA 	N

BCS

DTC Index

INFOID:000000009722476

NOTE:

The details of time display are as follows.

- CRNT: A malfunction is detected now.
- PAST: A malfunction was detected in the past.

IGN counter is displayed on Freeze Frame Data. For details of Freeze Frame Data, refer to [BCS-18. "COMMON ITEM : CONSULT Function \(BCM - COMMON ITEM\)"](#).

BCM (BODY CONTROL MODULE)

< ECU DIAGNOSIS INFORMATION >

CONSULT display	Fail-safe	Freeze Frame Data •Vehicle Speed •Odo/Trip Meter •Vehicle Condition	Intelligent Key warning lamp ON	Tire pressure monitor warning lamp ON	Reference
No DTC is detected. further testing may be required.	—	—	—	—	—
U1000: CAN COMM	—	—	—	—	BCS-42
U1010: CONTROL UNIT(CAN)	—	—	—	—	BCS-43
U0415: VEHICLE SPEED SIG	—	—	—	—	BCS-44
B2190: NATS ANTENNA AMP	×	—	—	—	SEC-42
B2191: DIFFERENCE OF KEY	×	—	—	—	SEC-45
B2192: ID DISCORD BCM-ECM	×	—	—	—	SEC-46
B2193: CHAIN OF BCM-ECM	×	—	—	—	SEC-48
B2195: ANTI SCANNING	×	—	—	—	SEC-49
B2553: IGNITION RELAY	—	×	—	—	PCS-50
B2555: STOP LAMP	—	×	—	—	SEC-50
B2556: PUSH-BTN IGN SW	—	×	×	—	SEC-52
B2557: VEHICLE SPEED	×	×	×	—	SEC-54
B2560: STARTER CONT RELAY	×	×	×	—	SEC-55
B2562: LOW VOLTAGE	—	×	—	—	BCS-45
B2601: SHIFT POSITION	×	×	×	—	SEC-56
B2602: SHIFT POSITION	×	×	×	—	SEC-59
B2603: SHIFT POSI STATUS	×	×	×	—	SEC-61
B2604: PNP SW	×	×	×	—	SEC-64
B2605: PNP SW	×	×	×	—	SEC-66
B2608: STARTER RELAY	×	×	×	—	SEC-68
B260A: IGNITION RELAY	×	×	×	—	PCS-52
B260F: ENG STATE SIG LOST	×	×	×	—	SEC-70
B2614: ACC RELAY CIRC	—	×	×	—	PCS-54
B2615: BLOWER RELAY CIRC	—	×	×	—	PCS-57
B2616: IGN RELAY CIRC	—	×	×	—	PCS-60
B2617: STARTER RELAY CIRC	×	×	×	—	SEC-72
B2618: BCM	×	×	×	—	PCS-63
B261A: PUSH-BTN IGN SW	—	×	×	—	SEC-75
B261E: VEHICLE TYPE	×	×	× (Turn ON for 15 seconds)	—	SEC-78
B2622: INSIDE ANTENNA	—	×	—	—	DLK-91
B2623: INSIDE ANTENNA	—	×	—	—	DLK-93
B26EA: KEY REGISTRATION	—	×	× (Turn ON for 15 seconds)	—	SEC-71
C1704: LOW PRESSURE FL	—	—	—	×	WT-23
C1705: LOW PRESSURE FR	—	—	—	×	
C1706: LOW PRESSURE RR	—	—	—	×	
C1707: LOW PRESSURE RL	—	—	—	×	

BCM (BODY CONTROL MODULE)

< ECU DIAGNOSIS INFORMATION >

CONSULT display	Fail-safe	Freeze Frame Data •Vehicle Speed •Odo/Trip Meter •Vehicle Condition	Intelligent Key warning lamp ON	Tire pressure monitor warning lamp ON	Reference
C1708: [NO DATA] FL	—	—	—	×	WT-25
C1709: [NO DATA] FR	—	—	—	×	
C1710: [NO DATA] RR	—	—	—	×	
C1711: [NO DATA] RL	—	—	—	×	
C1716: [PRESSDATA ERR] FL	—	—	—	×	WT-28
C1717: [PRESSDATA ERR] FR	—	—	—	×	
C1718: [PRESSDATA ERR] RR	—	—	—	×	
C1719: [PRESSDATA ERR] RL	—	—	—	×	
C1729: VHCL SPEED SIG ERR	—	—	—	×	WT-29
C1734: CONTROL UNIT	—	—	—	×	WT-30

A
B
C
D
E
F
G
H
I
J
K
L
N
O
P

BCS

COMBINATION SWITCH SYSTEM SYMPTOMS

< SYMPTOM DIAGNOSIS >

SYMPTOM DIAGNOSIS

COMBINATION SWITCH SYSTEM SYMPTOMS

Symptom Table

INFOID:000000009722477

1. Perform "Data Monitor" of CONSULT to check for any malfunctioning item.
2. Check the malfunction combinations.

Malfunction item: x

Malfunction combination	Data monitor item																
	FR WIPER HI	FR WIPER LOW	FR WASHER SW	FR WIPER INT	RR WIPER ON	RR WIPER INT	RR WASHER SW	INT VOLUME	TURN SIGNAL R	TURN SIGNAL L	TAIL LAMP SW	HI BEAM SW	HEAD LAMP SW 1	HEAD LAMP SW 2	PASSING SW	AUTO LIGHT SW	FR FOG SW
A		x	x						x	x							
B	x			x									x		x		
C							x	x				x		x			
D						x		x			x					x	
E					x			x									x
F	x					x		x									
G			x		x		x	x									
H		x		x												x	
I										x				x	x		x
J									x		x	x	x				
K	All Items																
L	If only one item is detected or the item is not applicable to the combinations A to K																

3. Identify the malfunctioning part from the agreed combination and repair or replace the part.

Malfunction combination	Malfunctioning part	Repair or replace
A	Combination switch INPUT 1 circuit	Inspect the combination switch input circuit applicable to the malfunctioning part. Refer to BCS-47, "Diagnosis Procedure" .
B	Combination switch INPUT 2 circuit	
C	Combination switch INPUT 3 circuit	
D	Combination switch INPUT 4 circuit	
E	Combination switch INPUT 5 circuit	
F	Combination switch OUTPUT 1 circuit	Inspect the combination switch output circuit applicable to the malfunctioning part. Refer to BCS-49, "Diagnosis Procedure" .
G	Combination switch OUTPUT 2 circuit	
H	Combination switch OUTPUT 3 circuit	
I	Combination switch OUTPUT 4 circuit	
J	Combination switch OUTPUT 5 circuit	
K	BCM	Replace BCM. Refer to BCS-98, "Exploded View" .
L	Combination switch	Replace the combination switch.

NORMAL OPERATING CONDITION

< SYMPTOM DIAGNOSIS >

NORMAL OPERATING CONDITION

Description

INFOID:000000009722478

SHIPPING MODE

- Shipping mode inhibits battery power consumption during transportation or storage of the vehicle. Vehicle is set to shipping mode before being shipped from the factory.
- When ignition switch is OFF, BCM operates shipping mode.
- BCM control functions are limited in shipping mode. The limited items that are not operated during the shipping mode are as follows.
 - Door lock and unlock switch function
 - Remote keyless entry function
 - Theft warning alarm function
 - Lighting & turn signal switch function
 - Interior room lamp timer control function
- For shipping mode cancel operation, refer to [BCS-7, "Description"](#).

NOTE:

Do not cancel shipping mode during storage of the vehicle. Always cancel shipping mode before delivery of the vehicle to customer.

A
B
C
D
E
F
G
H
I
J
K
L

BCS

N
O
P

PRECAUTIONS

< PRECAUTION >

PRECAUTION

PRECAUTIONS

FOR USA AND CANADA

FOR USA AND CANADA : Precautions for Removing of Battery Terminal

INFOID:000000010032047

- When removing the 12V battery terminal, turn OFF the ignition switch and wait at least 30 seconds.

NOTE:

ECU may be active for several tens of seconds after the ignition switch is turned OFF. If the battery terminal is removed before ECU stops, then a DTC detection error or ECU data corruption may occur.

- For vehicles with the 2-batteries, be sure to connect the main battery and the sub battery before turning ON the ignition switch.

NOTE:

If the ignition switch is turned ON with any one of the terminals of main battery and sub battery disconnected, then DTC may be detected.

- After installing the 12V battery, always check "Self Diagnosis Result" of all ECUs and erase DTC.

NOTE:

The removal of 12V battery may cause a DTC detection error.

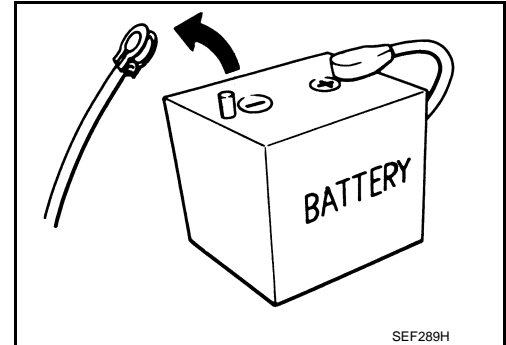

FOR USA AND CANADA : Precaution for Supplemental Restraint System (SRS) "AIR BAG" and "SEAT BELT PRE-TENSIONER"

INFOID:000000009722479

The Supplemental Restraint System such as "AIR BAG" and "SEAT BELT PRE-TENSIONER", used along with a front seat belt, helps to reduce the risk or severity of injury to the driver and front passenger for certain types of collision. This system includes seat belt switch inputs and dual stage front air bag modules. The SRS system uses the seat belt switches to determine the front air bag deployment, and may only deploy one front air bag, depending on the severity of a collision and whether the front occupants are belted or unbelted. Information necessary to service the system safely is included in the "SRS AIR BAG" and "SEAT BELT" of this Service Manual.

WARNING:

Always observe the following items for preventing accidental activation.

- To avoid rendering the SRS inoperative, which could increase the risk of personal injury or death in the event of a collision that would result in air bag inflation, all maintenance must be performed by an authorized NISSAN/INFINITI dealer.
- Improper maintenance, including incorrect removal and installation of the SRS, can lead to personal injury caused by unintentional activation of the system. For removal of Spiral Cable and Air Bag Module, see "SRS AIR BAG".
- Never use electrical test equipment on any circuit related to the SRS unless instructed to in this Service Manual. SRS wiring harnesses can be identified by yellow and/or orange harnesses or harness connectors.

PRECAUTIONS WHEN USING POWER TOOLS (AIR OR ELECTRIC) AND HAMMERS

WARNING:

Always observe the following items for preventing accidental activation.

- When working near the Air Bag Diagnosis Sensor Unit or other Air Bag System sensors with the ignition ON or engine running, never use air or electric power tools or strike near the sensor(s) with a hammer. Heavy vibration could activate the sensor(s) and deploy the air bag(s), possibly causing serious injury.
- When using air or electric power tools or hammers, always switch the ignition OFF, disconnect the battery, and wait at least 3 minutes before performing any service.

FOR MEXICO

PRECAUTIONS

< PRECAUTION >

FOR MEXICO : Precautions for Removing of Battery Terminal

INFOID:0000000110032048

- When removing the 12V battery terminal, turn OFF the ignition switch and wait at least 30 seconds.

NOTE:

ECU may be active for several tens of seconds after the ignition switch is turned OFF. If the battery terminal is removed before ECU stops, then a DTC detection error or ECU data corruption may occur.

- For vehicles with the 2-batteries, be sure to connect the main battery and the sub battery before turning ON the ignition switch.

NOTE:

If the ignition switch is turned ON with any one of the terminals of main battery and sub battery disconnected, then DTC may be detected.

- After installing the 12V battery, always check "Self Diagnosis Result" of all ECUs and erase DTC.

NOTE:

The removal of 12V battery may cause a DTC detection error.

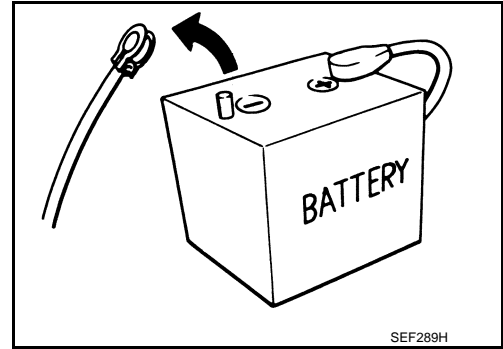

FOR MEXICO : Precaution for Supplemental Restraint System (SRS) "AIR BAG" and "SEAT BELT PRE-TENSIONER"

INFOID:000000009722480

The Supplemental Restraint System such as "AIR BAG" and "SEAT BELT PRE-TENSIONER", used along with a front seat belt, helps to reduce the risk or severity of injury to the driver and front passenger for certain types of collision. Information necessary to service the system safely is included in the "SRS AIR BAG" and "SEAT BELT" of this Service Manual.

WARNING:

Always observe the following items for preventing accidental activation.

- To avoid rendering the SRS inoperative, which could increase the risk of personal injury or death in the event of a collision that would result in air bag inflation, all maintenance must be performed by an authorized NISSAN/INFINITI dealer.
- Improper maintenance, including incorrect removal and installation of the SRS, can lead to personal injury caused by unintentional activation of the system. For removal of Spiral Cable and Air Bag Module, see "SRS AIR BAG".
- Never use electrical test equipment on any circuit related to the SRS unless instructed to in this Service Manual. SRS wiring harnesses can be identified by yellow and/or orange harnesses or harness connectors.

PRECAUTIONS WHEN USING POWER TOOLS (AIR OR ELECTRIC) AND HAMMERS

WARNING:

Always observe the following items for preventing accidental activation.

- When working near the Air Bag Diagnosis Sensor Unit or other Air Bag System sensors with the ignition ON or engine running, never use air or electric power tools or strike near the sensor(s) with a hammer. Heavy vibration could activate the sensor(s) and deploy the air bag(s), possibly causing serious injury.
- When using air or electric power tools or hammers, always switch the ignition OFF, disconnect the battery, and wait at least 3 minutes before performing any service.

BCM (BODY CONTROL MODULE)

< REMOVAL AND INSTALLATION >

REMOVAL AND INSTALLATION

BCM (BODY CONTROL MODULE)

Exploded View

INFOID:000000009722481

NOTE:

Before replacing BCM, perform "READ CONFIGURATION" to save or print current vehicle specification. Refer to [BCS-3. "ADDITIONAL SERVICE WHEN REPLACING CONTROL UNIT \(BCM\) : Description"](#).

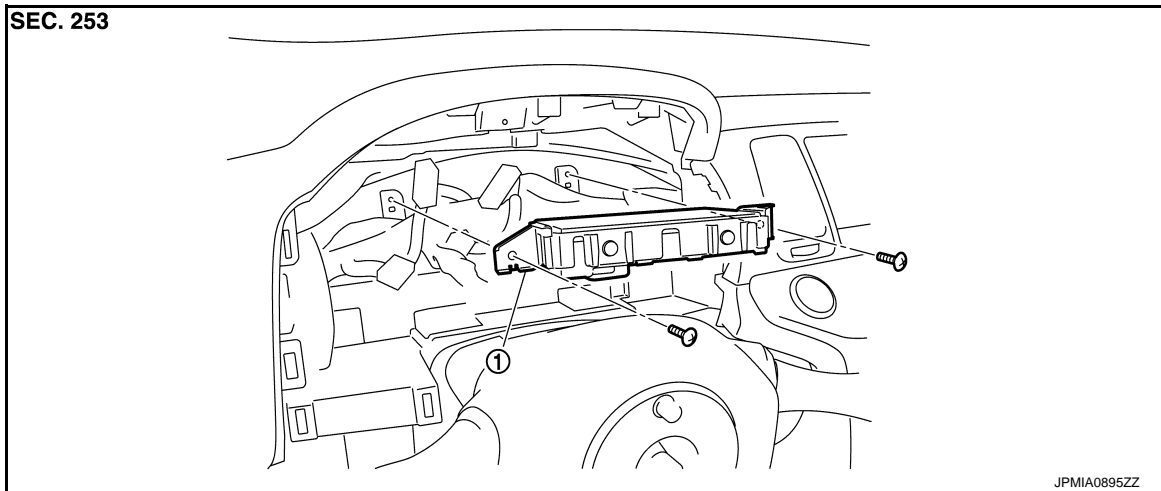

1. BCM

Removal and Installation

INFOID:000000009722482

NOTE:

Before replacing BCM, perform "READ CONFIGURATION" to save or print current vehicle specification. Refer to [BCS-3. "ADDITIONAL SERVICE WHEN REPLACING CONTROL UNIT \(BCM\) : Description"](#).

REMOVAL

1. Remove combination meter. Refer to [MWI-105. "Exploded View"](#).
2. Remove screws.
3. Remove BCM and disconnect the connector.

INSTALLATION

Install in the reverse order of removal.

CAUTION:

Be sure to perform "WRITE CONFIGURATION" when replacing BCM. Or not doing so, BCM control function does not operate normally.

NOTE:

Be sure to perform the system initialization (NATS) when replacing BCM. Refer to [BCS-3. "ADDITIONAL SERVICE WHEN REPLACING CONTROL UNIT \(BCM\) : Work Procedure"](#).

COMBINATION SWITCH

< REMOVAL AND INSTALLATION >

COMBINATION SWITCH

Exploded View

INFOID:000000009722483

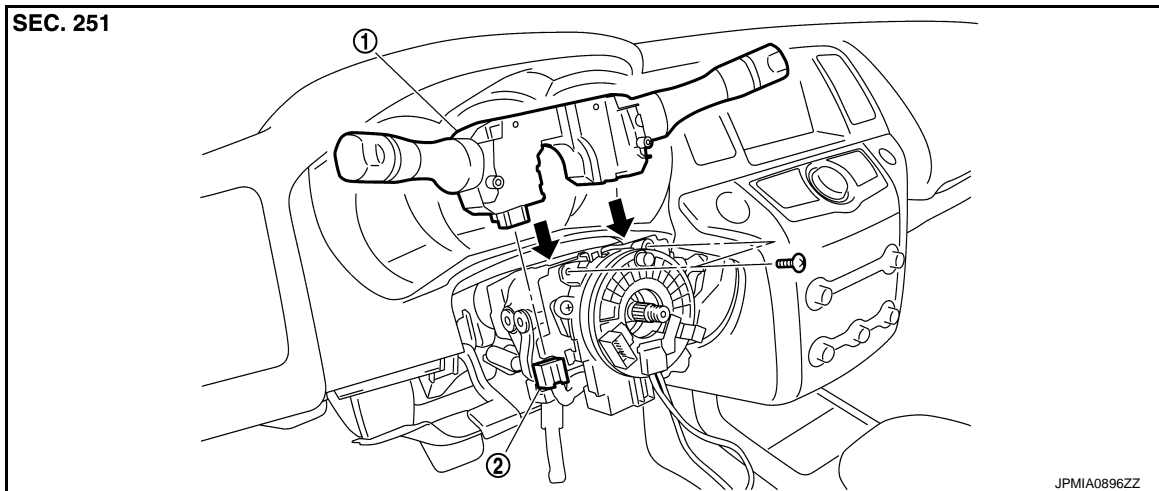

1. Combination switch

2. Combination switch connector

Removal and Installation

INFOID:000000009722484

REMOVAL

1. Remove steering column cover. Refer to [IP-14. "Exploded View"](#).
2. Remove screws.
3. Disconnect the connector.
4. Pull up the combination switch to remove it.

INSTALLATION

Install in the reverse order of removal.

A
B
C
D
E
F
G
H
I
J
K
L

BCS

N
O
P