

SECTION **RSU**  
 REAR SUSPENSION

A  
B  
C  
D

RSU

CONTENTS

<b>SYMPTOM DIAGNOSIS</b> .....	2	Disposal .....	11	F
<b>NOISE, VIBRATION AND HARSHNESS (NVH) TROUBLESHOOTING</b> .....	2	<b>RADIUS ROD</b> .....	12	G
NVH Troubleshooting Chart .....	2	Exploded View .....	12	
<b>PRECAUTION</b> .....	3	Removal and Installation .....	12	
<b>PRECAUTIONS</b> .....	3	Inspection .....	12	
Precautions for Suspension .....	3	<b>FRONT LOWER LINK</b> .....	14	H
Precautions for Removing of Battery Terminal .....	3	Exploded View .....	14	
<b>PREPARATION</b> .....	4	Removal and Installation .....	14	
<b>PREPARATION</b> .....	4	Inspection .....	14	I
Commercial Service Tool .....	4	<b>REAR STABILIZER</b> .....	15	J
<b>PERIODIC MAINTENANCE</b> .....	5	Exploded View .....	15	
<b>REAR SUSPENSION ASSEMBLY</b> .....	5	Removal and Installation .....	15	
Inspection .....	5	Inspection .....	15	
<b>WHEEL ALIGNMENT</b> .....	6	<b>REAR SUSPENSION ARM</b> .....	16	K
Inspection .....	6	Exploded View .....	16	
Adjustment .....	6	Removal and Installation .....	16	
<b>REMOVAL AND INSTALLATION</b> .....	8	Inspection .....	16	L
<b>REAR LOWER LINK &amp; COIL SPRING</b> .....	8	<b>UNIT REMOVAL AND INSTALLATION</b> .....	18	
Exploded View .....	8	<b>REAR SUSPENSION MEMBER</b> .....	18	M
Removal and Installation .....	8	Exploded View .....	18	
Inspection .....	9	Removal and Installation .....	18	
<b>REAR SHOCK ABSORBER</b> .....	10	Inspection .....	19	N
Exploded View .....	10	<b>SERVICE DATA AND SPECIFICATIONS (SDS)</b> .....	20	O
Removal and Installation .....	10	<b>SERVICE DATA AND SPECIFICATIONS (SDS)</b> .....	20	P
Disassembly and Assembly .....	10	Wheel Alignment .....	20	
Inspection .....	11	Ball Joint .....	20	
		Wheelarch Height .....	20	

# NOISE, VIBRATION AND HARSHNESS (NVH) TROUBLESHOOTING

< SYMPTOM DIAGNOSIS >

## SYMPTOM DIAGNOSIS

### NOISE, VIBRATION AND HARSHNESS (NVH) TROUBLESHOOTING

#### NVH Troubleshooting Chart

INFOID:000000009721420

Use chart below to find the cause of the symptom. If necessary, repair or replace these parts.

Symptom		Possible cause and SUSPECTED PARTS													Reference		
		Improper installation, looseness	Shock absorber deformation, damage or deflection	Bushing or mounting deterioration	Parts interference	Spring fatigue	Suspension looseness	Incorrect wheel alignment	Stabilizer bar fatigue	PROPELLER SHAFT (AWD)	DIFFERENTIAL (AWD)	REAR AXLE AND REAR SUSPENSION	TIRE	ROAD WHEEL		DRIVE SHAFT (AWD)	BRAKE
REAR SUSPENSION	Noise	x	x	x	x	x	x			x	x	x	x	x	x	x	RSU-8, RSU-10, RSU-12, RSU-14, RSU-15, RSU-16, RSU-18
	Shake	x	x	x	x		x			x		x	x	x	x		RSU-10
	Vibration	x	x	x	x	x				x		x	x		x		—
	Shimmy	x	x	x	x			x				x	x	x			RSU-9
	Judder	x	x	x								x	x	x			RSU-8, RSU-10, RSU-12, RSU-14, RSU-15, RSU-16, RSU-18
	Poor quality ride or handling	x	x	x	x	x		x	x			x	x	x			RSU-6
																	RSU-15
																	NVH in DLN section
																	NVH in DLN section
																	NVH in RAX and RSU sections
																	NVH in WT section
																	NVH in WT section
																	NVH in RAX section
																	NVH in BR section

x: Applicable

# PRECAUTIONS

< PRECAUTION >

## PRECAUTION

### PRECAUTIONS

#### Precautions for Suspension

INFOID:000000009721421

- When installing rubber bushings, the final tightening must be carried out under unladen conditions with tires on ground. Spilled oil might shorten the life of rubber bushings. Be sure to wipe off any spilled oil.
- Unladen conditions mean that fuel, engine coolant and lubricant are full. Spare tire, jack, hand tools and mats are in designated positions.
- After servicing suspension parts, be sure to check wheel alignment.
- Self-lock nuts are not reusable. Always use new ones when installing. Since new self-lock nuts are pre-oiled, tighten as they are.

#### Precautions for Removing of Battery Terminal

INFOID:00000000973194

- When removing the 12V battery terminal, turn OFF the ignition switch and wait at least 30 seconds.

**NOTE:**

ECU may be active for several tens of seconds after the ignition switch is turned OFF. If the battery terminal is removed before ECU stops, then a DTC detection error or ECU data corruption may occur.

- For vehicles with the 2-batteries, be sure to connect the main battery and the sub battery before turning ON the ignition switch.

**NOTE:**

If the ignition switch is turned ON with any one of the terminals of main battery and sub battery disconnected, then DTC may be detected.

- After installing the 12V battery, always check "Self Diagnosis Result" of all ECUs and erase DTC.

**NOTE:**

The removal of 12V battery may cause a DTC detection error.

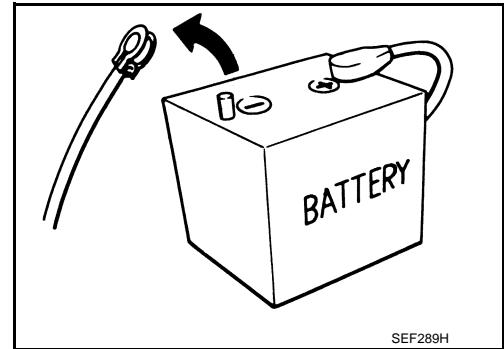

A

B

C

D

RSU

F

G

H

I

J

K

L

M

N

O

P

# PREPARATION

< PREPARATION >

## PREPARATION

### PREPARATION

Commercial Service Tool

INFOID:000000009721422

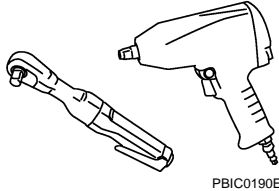
Tool name	Description
Power tool  <p>PBIC0190E</p>	Loosening bolts and nuts

# REAR SUSPENSION ASSEMBLY

< PERIODIC MAINTENANCE >

## PERIODIC MAINTENANCE

### REAR SUSPENSION ASSEMBLY

#### Inspection

INFOID:000000009721423

#### COMPONENT PART

Check the mounting conditions (looseness, backlash) of each component and component conditions (wear, damage) are normal.

#### Ball Joint Axial End Play

Move axle side of suspension arm in the axial direction by hand.  
Check there is no end play.

**Axial end play** : Refer to [RSU-20, "Ball Joint"](#).

#### CAUTION:

- Never depress brake pedal when measuring.
- Never perform with tires on level ground.
- Be careful not to damage ball joint boot. Never damage the installation position by applying excessive force.

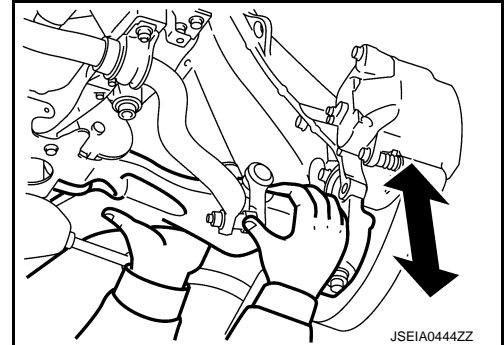

#### SHOCK ABSORBER ASSEMBLY

Check for oil leakage, damage, and replace if necessary.

A  
B  
C  
D  
RSU  
F  
G  
H  
I  
J  
K  
L  
M  
N  
O  
P

# WHEEL ALIGNMENT

< PERIODIC MAINTENANCE >

## WHEEL ALIGNMENT

### Inspection

INFOID:000000009721424

#### DESCRIPTION

Measure wheel alignment under unladen conditions.

#### NOTE:

"Unladen conditions" means that fuel, engine coolant, and lubricant are full. Spare tire, jack, hand tools and mats are in designated positions.

#### PRELIMINARY CHECK

Check the following:

- Tires for improper air pressure and wear. Refer to [WT-52, "Tire Air Pressure"](#).
- Road wheels for runout.
- Wheel bearing axial end play. Refer to [RAX-6, "Inspection"](#) (2WD), [RAX-13, "Inspection"](#) (AWD).
- Shock absorber operation.
- Each mounting point of axle and suspension for looseness and deformation.
- Each of front lower link, rear lower link, radius rod, rear suspension member, suspension arm and shock absorber for cracks, deformation, and other damage.
- Vehicle height (posture).

#### GENERAL INFORMATION AND RECOMMENDATIONS

- A four-wheel thrust alignment should be performed.
- This type of alignment is recommended for any NISSAN/INFINITI vehicle.
- The four-wheel "thrust" process helps ensure that the vehicle is properly aligned and the steering wheel is centered.
- The alignment rack itself should be capable of accepting any NISSAN/INFINITI vehicle.
- The rack should be checked to ensure that it is level.
- Make sure the machine is properly calibrated.
- Your alignment equipment should be regularly calibrated in order to give correct information.
- Check with the manufacturer of your specific equipment for their recommended Service/Calibration Schedule.

#### ALIGNMENT PROCESS

#### IMPORTANT:

Use only the alignment specifications listed in this Service Manual.

- When displaying the alignment settings, many alignment machines use "indicators": (Green/red, plus or minus, Go/No Go). **Never use these indicators.**
- The alignment specifications programmed into your machine that operate these indicators may not be correct.
- This may result in an ERROR.
- Most camera-type alignment machines are equipped with both "Rolling Compensation" method and optional "Jacking Compensation" method to "compensate" the alignment targets or head units. "Rolling Compensation" is the preferred method.
- If using the "Rolling Compensation" method, after installing the alignment targets or head units, push or pull on the rear wheel to move the vehicle. **Do not push or pull on the vehicle body.**
- If using the "Jacking Compensation" method, after installing the alignment targets or head units, raise the vehicle and rotate the wheels 1/2 turn both ways.

#### NOTE:

- Do not use the "Rolling Compensation" method if you are using sensor-type alignment equipment.
- Follow all instructions for the alignment machine you're using for more information.

### Adjustment

INFOID:000000009721425

#### CAMBER

# WHEEL ALIGNMENT

## < PERIODIC MAINTENANCE >

- If camber is exceeds the standard value, adjust with adjusting bolt (1) in front lower link (2).

**Camber:** Refer to [RSU-20, "Wheel Alignment"](#).

### CAUTION:

**After adjusting camber, be sure to check toe-in.**

- If camber is not still within the specification, inspect and replace any damaged or worn suspension parts.

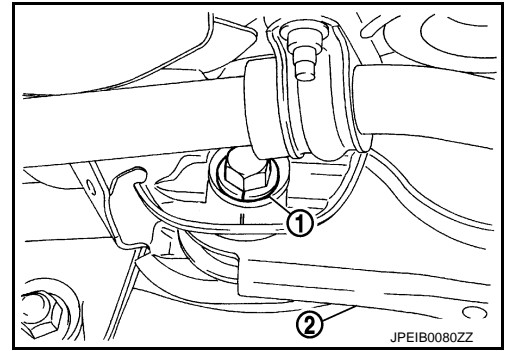

## TOE-IN

- If toe-in is exceeds the standard value, adjust with adjusting bolt (1) in rear lower link (2).

**Toe-In:** Refer to [RSU-20, "Wheel Alignment"](#).

### CAUTION:

- **Be sure to adjust equally on right and left side with adjusting bolt.**
- **When tightening the nut firmly and checking the torque, use a wrench to prevent the turning of the bolt.**
- If toe-in is not still within the specification, inspect and replace any damaged or worn suspension parts.
- After toe-in adjustment, adjust neutral position of steering angle sensor. Refer to [BRC-9, "ADJUSTMENT OF STEERING ANGLE SENSOR NEUTRAL POSITION : Special Repair Requirement"](#).

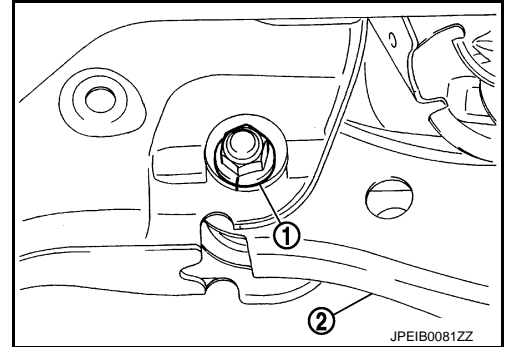

A  
B  
C  
D  
E  
F  
G  
H  
I  
J  
K  
L  
M  
N  
O  
P

RSU

# REAR LOWER LINK & COIL SPRING

< REMOVAL AND INSTALLATION >

## REMOVAL AND INSTALLATION

### REAR LOWER LINK & COIL SPRING

Exploded View

INFOID:000000009721426

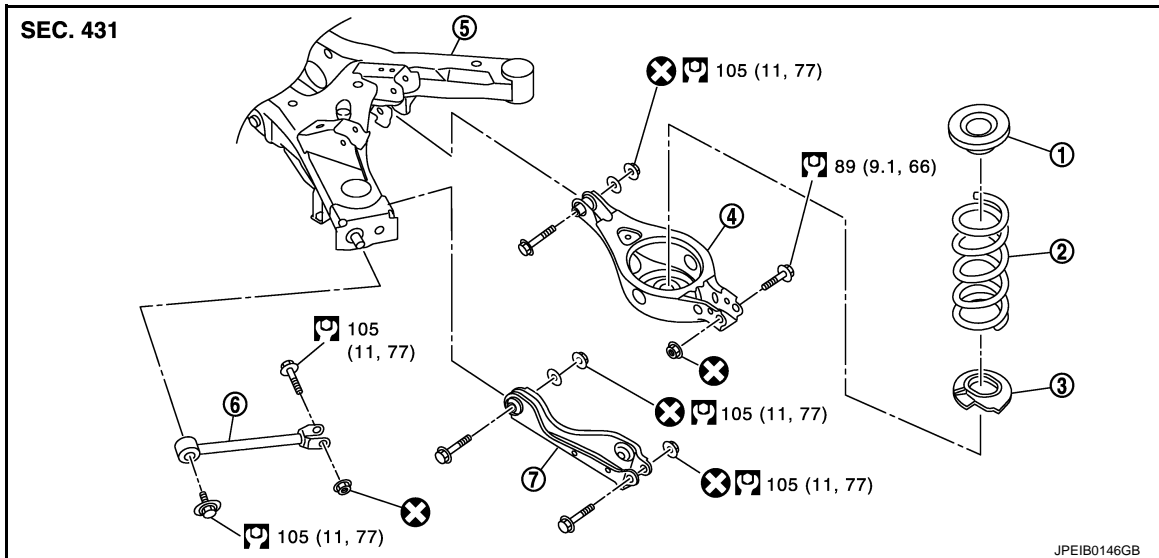

- |                     |                           |                |
|---------------------|---------------------------|----------------|
| 1. Upper seat       | 2. Coil spring            | 3. Rubber seat |
| 4. Rear lower link  | 5. Rear suspension member | 6. Radius rod  |
| 7. Front lower link |                           |                |

Refer to [GI-4, "Components"](#) for symbols in the figure.

## Removal and Installation

INFOID:000000009721427

### REMOVAL

1. Remove tires with power tool.
2. Remove stabilizer connecting rod (lower side). Refer to [RSU-15, "Exploded View"](#).
3. Set jack under rear lower link.
4. Loosen rear lower link mounting bolt and nut (rear suspension member side), and then remove rear lower link mounting bolt and nut (axle housing side) with power tool.
5. Slowly lower jack, then remove upper seat, coil spring and rubber seat from rear lower link.
6. Remove rear lower link mounting bolt and nut (rear suspension member side), and remove rear lower link.

### INSTALLATION

Note the following, and install in the reverse order of removal.

- Make sure that upper seat is attached as shown in the figure.

#### CAUTION:

- **Make sure keep the upper seat (1) to place protrusion for projection (A) on outside of vehicle (lateral direction of vehicle).**
- **Make sure that the projection (C) on upper seat inside is securely fitted on the bracket (2) tabs (B).**

⇐ : Body

- Match up rubber seat indentions and rear lower link grooves and attach.

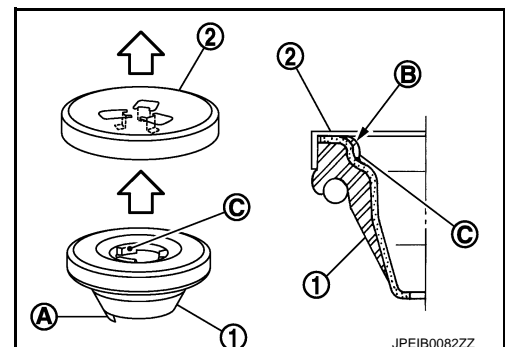



## REAR LOWER LINK & COIL SPRING

### < REMOVAL AND INSTALLATION >

- Install coil spring by aligning lower end of the coil spring to step (A) between rubber seat (1) and rear lower link (2).

**CAUTION:**

**Set coil spring so that its paint marks are aligned with the positions of 3.5 turns (2 places) and 4.5 turns (1 place) from the bottom end of the coil spring.**

- Perform the final tightening of rear suspension member and axle installation position (rubber bushing) under unladen condition with tires on level ground.

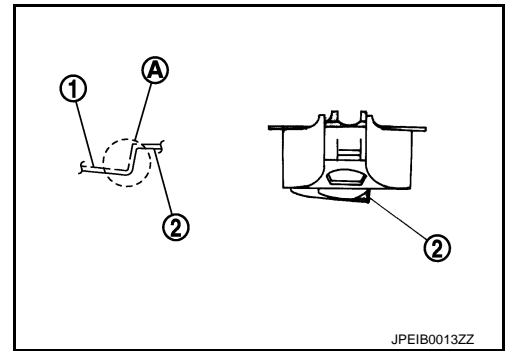

### Inspection

#### INSPECTION AFTER REMOVAL

Check rear lower link, bushing and coil spring for deformation, crack, and damage. Replace it if necessary.

#### INSPECTION AFTER INSTALLATION

1. Check wheel alignment. Refer to [RSU-6, "Inspection"](#).
2. Adjust neutral position of steering angle sensor. Refer to [BRC-9, "ADJUSTMENT OF STEERING ANGLE SENSOR NEUTRAL POSITION : Special Repair Requirement"](#).

A  
B  
C  
D

INFOID:000000009721428

RSU

F  
G  
H  
I  
J  
K  
L  
M  
N  
O  
P

# REAR SHOCK ABSORBER

< REMOVAL AND INSTALLATION >

## REAR SHOCK ABSORBER

Exploded View

INFOID:000000009721429

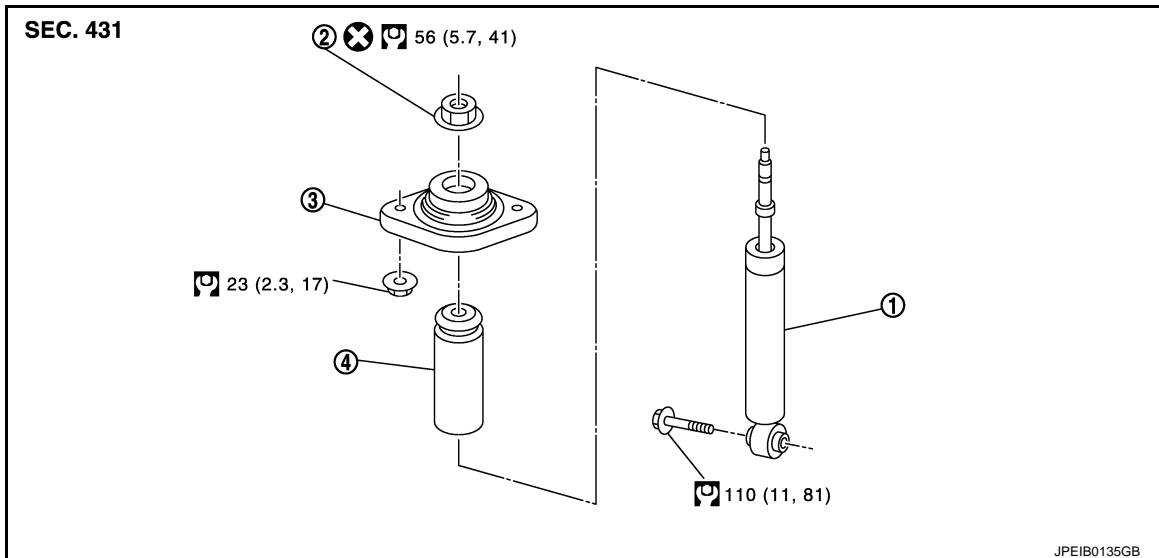

1. Shock absorber
2. Piston rod lock nut
3. Shock absorber mounting bracket
4. Bound bumper

Refer to [GI-4, "Components"](#) for symbols in the figure.

## Removal and Installation

INFOID:000000009721430

### REMOVAL

1. Remove tires with power tool.
2. Separate stabilizer connecting rod (lower side). Refer to [RSU-15, "Exploded View"](#).
3. Set suitable jack under axle housing to relieve the coil spring tension.
4. Remove shock absorber mounting bolt (lower side) with power tool.
5. Gradually lower the jack to remove it from front lower link.
6. Remove shock absorber assembly mounting nuts (upper side) () , and remove shock absorber assembly.

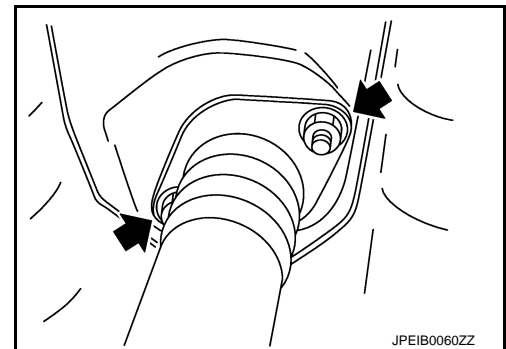

### INSTALLATION

Note the following, and install in the reverse order of removal.

- Perform final tightening of bolts and nuts at the shock absorber lower side (rubber bushing), under unladen conditions with tires on level ground.

## Disassembly and Assembly

INFOID:000000009721431

### DISASSEMBLY

#### **CAUTION:**

**Never damage shock absorber piston rod when removing components from shock absorber.**

# REAR SHOCK ABSORBER

## < REMOVAL AND INSTALLATION >

1. Wrap a shop cloth around lower side of shock absorber and fix it with a vise.  
**CAUTION:**  
**Never set the cylindrical part of shock absorber with a vise.**
2. Secure the piston rod tip so that piston rod does not turn, and remove piston rod lock nut.
3. Remove mounting bracket and bound bumper from shock absorber.

## ASSEMBLY

Install in the reverse order of disassembly.

## Inspection

INFOID:000000009721432

## INSPECTION AFTER REMOVAL

Check the following items, and replace the parts if necessary.

- Shock absorber assembly for deformation, cracks, damage.
- Welded and sealed areas for oil leakage.
- Piston rod for damage, uneven wear or distortion.
- Seal of shock absorber mounting bracket for cracks, damage and come off.

## INSPECTION AFTER DISASSEMBLY

### Bound Bumper

Check bound bumper for cracks and damage. Replace it if necessary.

### Shock Absorber

Check the following items, and replace the part if necessary.

- Shock absorber for deformation, cracks, and other damage.
- Piston rod for damage, uneven wear, and distortion.

## INSPECTION AFTER ASSEMBLY

Make sure piston rod on shock absorber is not damaged when attaching components to shock absorber.

## INSPECTION AFTER INSTALLATION

1. Check wheel alignment. Refer to [RSU-6, "Inspection"](#).
2. Adjust neutral position of steering angle sensor. Refer to [BRC-9, "ADJUSTMENT OF STEERING ANGLE SENSOR NEUTRAL POSITION : Special Repair Requirement"](#).

## Disposal

INFOID:000000009721433

1. Set shock absorber horizontally with the piston rod fully extended.
2. Drill 2 – 3 mm (0.08 – 0.12 in) hole at the position (●) from top as shown in the figure to release gas gradually.

### **CAUTION:**

- **Wear eye protection (safety glasses).**
- **Wear gloves.**
- **Be careful with metal chips or oil blown out by the compressed gas.**

### **NOTE:**

- Drill vertically in this direction (←).
- Directly to the outer tube avoiding brackets.
- The gas is clear, colorless, odorless, and harmless.

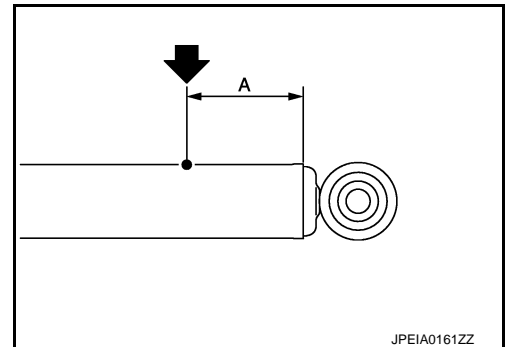

**A : 20 – 30 mm (0.79 – 1.18 in)**

3. Position the drilled hole downward and drain oil by moving the piston rod several times.

### **CAUTION:**

**Dispose of drained oil according to the law and local regulations.**

# RADIUS ROD

< REMOVAL AND INSTALLATION >

## RADIUS ROD

### Exploded View

INFOID:000000009721434

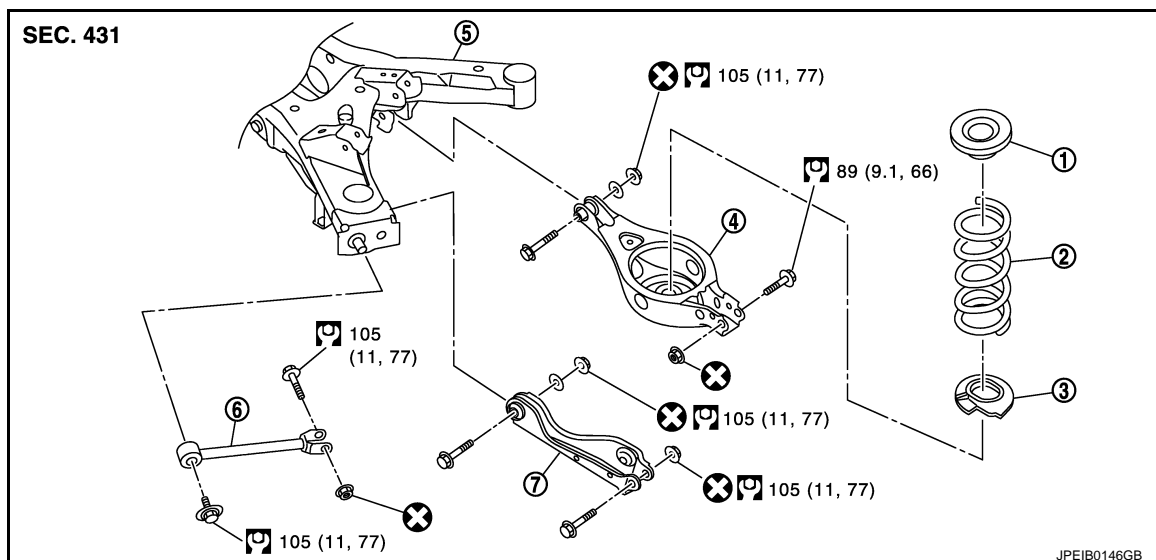

- |                     |                           |                |
|---------------------|---------------------------|----------------|
| 1. Upper seat       | 2. Coil spring            | 3. Rubber seat |
| 4. Rear lower link  | 5. Rear suspension member | 6. Radius rod  |
| 7. Front lower link |                           |                |

Refer to [GI-4, "Components"](#) for symbols in the figure.

## Removal and Installation

INFOID:000000009721435

### REMOVAL

1. Remove tire with power tool.
2. Remove wheel sensor and sensor harness. Refer to [BRC-124, "REAR WHEEL SENSOR : Exploded View"](#).
3. Remove rear lower link and coil spring. Refer to [RSU-8, "Exploded View"](#).
4. Remove shock absorber mounting bolt (lower side) with power tool. Refer to [RSU-10, "Exploded View"](#).
5. Remove front lower link mounting bolt and nut (axle housing side) with power tool. Refer to [RSU-14, "Exploded View"](#).
6. Loosen front lower link mounting bolt and nut (suspension member side). Refer to [RSU-14, "Exploded View"](#).
7. Remove radius rod mounting bolts and nuts (axle housing side) with power tool.
8. Remove radius rod mounting bolt (rear suspension member side) with power tool, then remove radius rod.

### INSTALLATION

Note the following, and install in the reverse order of removal.

- Perform final tightening of rear suspension member and axle installation position (rubber bushing), under unladen conditions with tires on level ground.

### Inspection

INFOID:000000009721436

#### INSPECTION AFTER REMOVAL

Check radius rod and bushing for any deformation, cracks, or damage. Replace if necessary.

#### INSPECTION AFTER INSTALLATION

1. Check wheel sensor harness for proper connection. Refer to [BRC-124, "REAR WHEEL SENSOR : Exploded View"](#).

## RADIUS ROD

### < REMOVAL AND INSTALLATION >

---

2. Check wheel alignment. Refer to [RSU-6, "Inspection"](#).
3. Adjust neutral position of steering angle sensor. Refer to [BRC-9, "ADJUSTMENT OF STEERING ANGLE SENSOR NEUTRAL POSITION : Special Repair Requirement"](#).

A

B

C

D

RSU

F

G

H

I

J

K

L

M

N

O

P

# FRONT LOWER LINK

< REMOVAL AND INSTALLATION >

## FRONT LOWER LINK

### Exploded View

INFOID:000000009721437

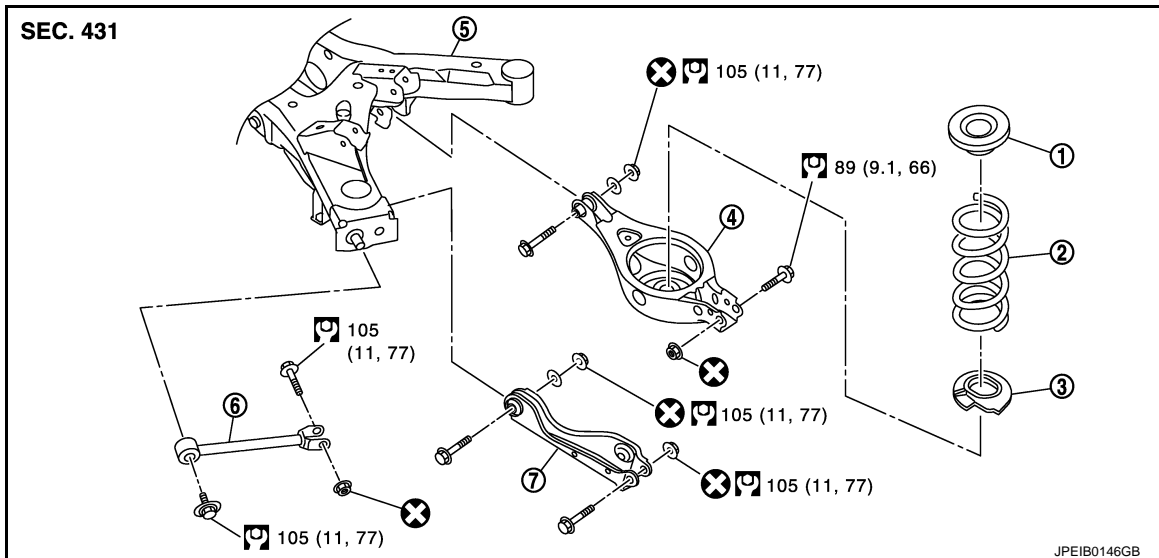

- |                     |                           |                |
|---------------------|---------------------------|----------------|
| 1. Upper seat       | 2. Coil spring            | 3. Rubber seat |
| 4. Rear lower link  | 5. Rear suspension member | 6. Radius rod  |
| 7. Front lower link |                           |                |

Refer to [GI-4, "Components"](#) for symbols in the figure.

## Removal and Installation

INFOID:000000009721438

### REMOVAL

1. Remove tire with power tool.
2. Remove wheel sensor and sensor harness. Refer to [BRC-124, "REAR WHEEL SENSOR : Exploded View"](#).
3. Remove rear lower link and coil spring. Refer to [RSU-8, "Exploded View"](#).
4. Remove shock absorber mounting bolt (lower side) with power tool. Refer to [RSU-10, "Exploded View"](#).
5. Remove stabilizer bushing and stabilizer clamp. Refer to [RSU-15, "Exploded View"](#).
6. Remove front lower link mounting bolts and nuts (rear suspension member side) with power tool.
7. Remove front lower link mounting bolts and nuts (axle housing side) with power tool.
8. Remove front lower link.

### INSTALLATION

Note the following, and install in the reverse order of removal.

- Perform final tightening of rear suspension member and axle installation position (rubber bushing), under unladen conditions with tires on level ground.

### Inspection

INFOID:000000009721439

#### INSPECTION AFTER REMOVAL

Check front lower link and bushing for any deformation, cracks, or damage. Replace if necessary.

#### INSPECTION AFTER INSTALLATION

1. Check wheel sensor harness for proper connection. Refer to [BRC-124, "REAR WHEEL SENSOR : Exploded View"](#).
2. Check wheel alignment. Refer to [RSU-6, "Inspection"](#).
3. Adjust neutral position of steering angle sensor. Refer to [BRC-9, "ADJUSTMENT OF STEERING ANGLE SENSOR NEUTRAL POSITION : Special Repair Requirement"](#).

# REAR STABILIZER

< REMOVAL AND INSTALLATION >

## REAR STABILIZER

### Exploded View

INFOID:000000009721440

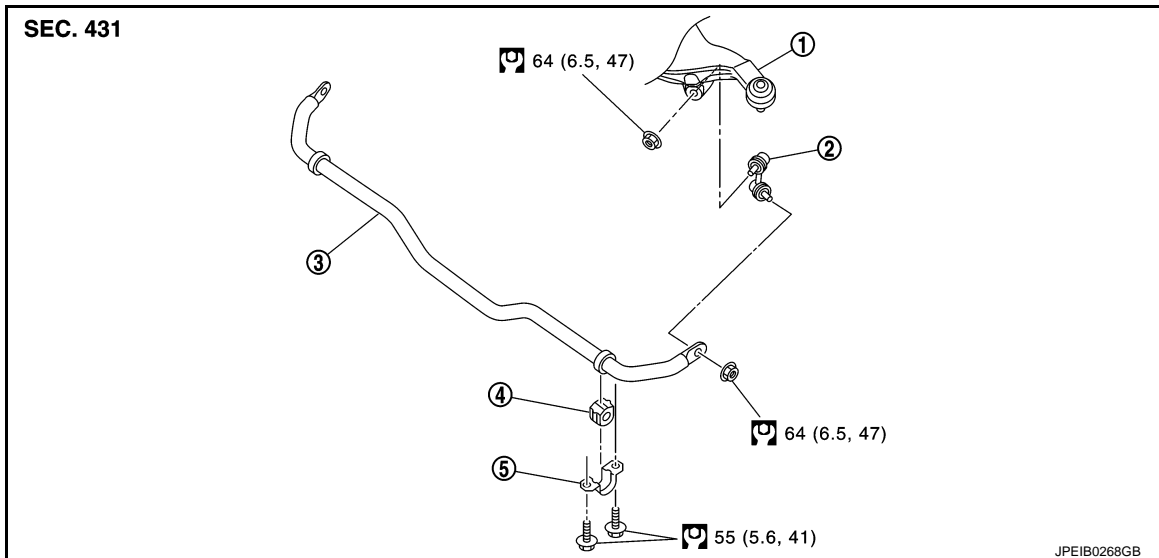

1. Suspension arm
2. Stabilizer connecting rod
3. Stabilizer bar
4. Stabilizer bushing
5. Stabilizer clamp

Refer to [GI-4, "Components"](#) for symbols in the figure.

### Removal and Installation

INFOID:000000009721441

#### REMOVAL

1. Remove tires with power tool.
2. Remove stabilizer connecting rod.  
**CAUTION:**  
**Apply a matching mark to identify the installation position.**
3. Remove mounting bolts on stabilizer clamp and remove stabilizer bar with power tool.

#### INSTALLATION

Note the following, and install in the reverse order of removal.

- Check the matching mark when installing.
- Tighten the mounting nut to the specified torque while holding a hexagonal part of stabilizer connecting rod side.

### Inspection

INFOID:000000009721442

#### INSPECTION AFTER REMOVAL

Check stabilizer bar, stabilizer bushing, stabilizer clamp, stabilizer connecting rod, for any deformation, crack or damage. Replace if necessary.

A  
B  
C  
D  
RSU  
F  
G  
H  
I  
J  
K  
L  
M  
N  
O  
P

# REAR SUSPENSION ARM

< REMOVAL AND INSTALLATION >

## REAR SUSPENSION ARM

### Exploded View

INFOID:000000009721443

#### NOTE:

Remove suspension arm with rear suspension member for AWD models. Refer to [RSU-18, "Exploded View"](#).

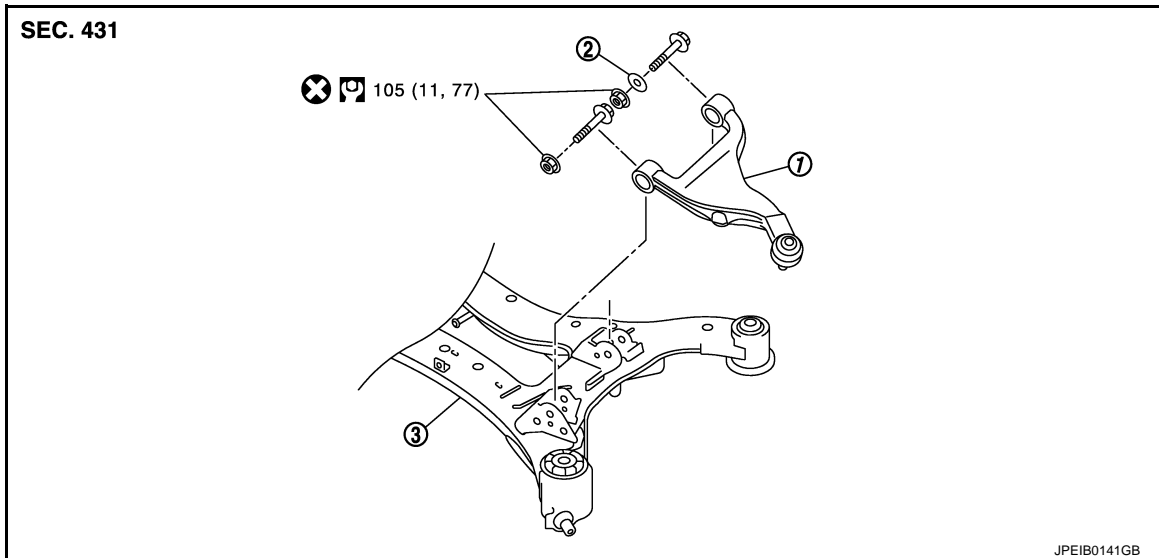

1. Suspension arm

2. Stopper rubber

3. Rear suspension member

Refer to [GI-4, "Components"](#) for symbols in the figure.

### Removal and Installation

INFOID:000000009721444

#### NOTE:

Remove suspension arm with rear suspension member for AWD models. Refer to [RSU-18, "Exploded View"](#).

#### REMOVAL

1. Remove tire with power tool.
2. Remove wheel sensor and sensor harness. Refer to [BRC-124, "REAR WHEEL SENSOR : Exploded View"](#).
3. Remove stabilizer connecting rod. Refer to [RSU-15, "Exploded View"](#).
4. Remove cotter pin of suspension arm ball joint, and loosen nut.
5. Use the ball joint remover to remove suspension arm from axle housing. Be careful not to damage ball joint boot.

#### CAUTION:

**Tighten temporarily mounting nut to prevent damage to threads and to prevent ball joint remover from coming off.**

6. Remove suspension arm.

#### INSTALLATION

Note the following, and install in the reverse order of removal.

- Perform final tightening of rear suspension member installation position (rubber bushing), under unladen conditions with tires on level ground.

### Inspection

INFOID:000000009721445

#### INSPECTION AFTER REMOVAL

##### Appearance

Check the following items, and replace the part if necessary.

- Suspension arm and bushing for deformation, cracks or damage.
- Boot of ball joint for cracks or damage, and also for grease leakage.



# REAR SUSPENSION ARM

## < REMOVAL AND INSTALLATION >

### Ball Joint Inspection

Manually move ball stud at least ten times by hand to check for smooth movement.

### Swing Torque Inspection

1. Before measurement, move ball stud at least ten times by hand to check for smooth movement.
2. Hook spring balance (A) at cotter pin mounting hole. Confirm spring balance measurement value is within specifications when ball stud begins moving.

**Swing torque** : Refer to [RSU-20. "Ball Joint"](#).

- If swing torque exceeds the standard range, replace suspension arm assembly.

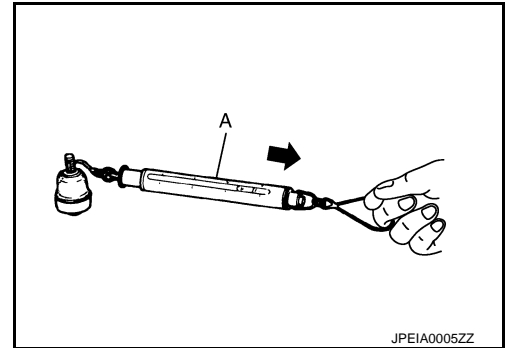

### Axial End Play Inspection

1. Before measurement, move ball stud at least ten times by hand to check for smooth movement.
2. Move tip of ball stud in axial direction to check for looseness.

**Axial end play** : Refer to [RSU-20. "Ball Joint"](#).

- If axial end play exceeds the standard range, replace suspension arm assembly.

## INSPECTION AFTER INSTALLATION

1. Check wheel sensor harness for proper connection. Refer to [BRC-124. "REAR WHEEL SENSOR : Exploded View"](#).
2. Check wheel alignment. Refer to [RSU-6. "Inspection"](#).
3. Adjust neutral position of steering angle sensor. Refer to [BRC-9. "ADJUSTMENT OF STEERING ANGLE SENSOR NEUTRAL POSITION : Special Repair Requirement"](#).

# REAR SUSPENSION MEMBER

< UNIT REMOVAL AND INSTALLATION >

## UNIT REMOVAL AND INSTALLATION

### REAR SUSPENSION MEMBER

Exploded View

INFOID:000000009721446

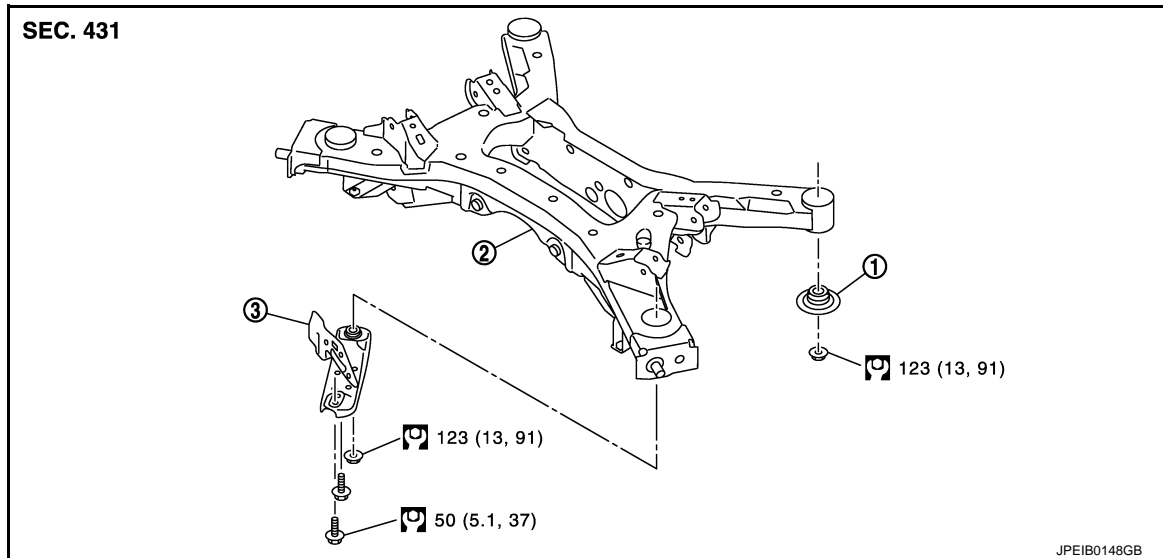

1. Rebound stopper                      2. Rear suspension member                      3. Member stay

Refer to [GI-4. "Components"](#) for symbols in the figure.

## Removal and Installation

INFOID:000000009721447

### REMOVAL

1. Remove tires with power tool.
  2. Remove caliper assembly. Hang caliper assembly in a place where it will not interfere with work. Refer to [BR-48. "BRAKE CALIPER ASSEMBLY : Exploded View"](#).
- CAUTION:**  
**Avoid depressing brake pedal while caliper assembly is removed.**
3. Remove wheel sensor and sensor harness. Refer to [BRC-124. "REAR WHEEL SENSOR : Exploded View"](#).
  4. Remove center muffler. Refer to [EX-5. "Exploded View"](#).
  5. Remove stabilizer bar. Refer to [RSU-15. "Exploded View"](#).
  6. Remove drive shaft (AWD models). Refer to [RAX-17. "Exploded View"](#).
  7. Remove propeller shaft (AWD models). Refer to [DLN-85. "Exploded View"](#).
  8. Remove harness from rear final drive and rear suspension member (AWD models).
  9. Remove rear final drive (AWD models). Refer to [DLN-104. "Exploded View"](#).
  10. Separate the attachment between parking brake cable and vehicle and rear suspension member. Refer to [PB-6. "Exploded View"](#).
  11. Remove rear lower link and coil spring. Refer to [RSU-8. "Exploded View"](#).
  12. Remove shock absorber (lower side). Refer to [RSU-10. "Exploded View"](#).
  13. Set suitable jack under rear suspension member.
  14. Remove member stay.
  15. Remove rear suspension member and rebound stopper.
  16. Slowly lower jack, then remove rear suspension member, suspension arm, radius rod, front lower link and axle from vehicle as a unit.
  17. Remove suspension arm. Refer to [RSU-16. "Exploded View"](#).
  18. Remove radius rod. Refer to [RSU-12. "Exploded View"](#).

# REAR SUSPENSION MEMBER

## < UNIT REMOVAL AND INSTALLATION >

19. Remove front lower link. Refer to [RSU-14. "Exploded View"](#).

### INSTALLATION

Note the following, and install in the reverse order of the removal.

- Perform the final tightening of each of parts under unladen conditions, which were removed when removing rear suspension assembly.
- Check wheel sensor harness for proper connection. Refer to [BRC-124. "REAR WHEEL SENSOR : Exploded View"](#).
- Never reuse cotter pin.

### Inspection

INFOID:000000009721448

### INSPECTION AFTER REMOVAL

Check rear suspension member for deformation, cracks, or any other damage. Replace if necessary.

### INSPECTION AFTER INSTALLATION

1. Check wheel sensor harness for proper connection. Refer to [BRC-124. "REAR WHEEL SENSOR : Exploded View"](#).
2. Adjust parking brake operation (stroke). Refer to [PB-3. "Inspection and Adjustment"](#).
3. Check wheel alignment. Refer to [RSU-6. "Inspection"](#).
4. Adjust neutral position of steering angle sensor. Refer to [BRC-9. "ADJUSTMENT OF STEERING ANGLE SENSOR NEUTRAL POSITION : Special Repair Requirement"](#).

A

B

C

D

RSU

F

G

H

I

J

K

L

M

N

O

P

## SERVICE DATA AND SPECIFICATIONS (SDS)

< SERVICE DATA AND SPECIFICATIONS (SDS)

# SERVICE DATA AND SPECIFICATIONS (SDS)

## SERVICE DATA AND SPECIFICATIONS (SDS)

### Wheel Alignment

INFOID:000000009721449

#### FOR USA AND MEXICO MODELS

Item		Standard	
Camber Degree minute (Decimal degree)	Minimum	-1° 13' (-1.21°)	
	Nominal	-0° 43' (-0.72°)	
	Maximum	-0° 13' (-0.21°)	
Toe-in	Total toe-in Distance	Minimum	In 0.9 mm (0.035 in)
		Nominal	In 2.7 mm (0.106 in)
		Maximum	In 4.5 mm (0.177 in)
	Total toe-angle Degree minute (Decimal degree)	Minimum	In 0° 04' (In 0.07°)
		Nominal	In 0° 12' (In 0.20°)
		Maximum	In 0° 20' (In 0.33°)

Measure value under unladen\* conditions.

\*: Fuel, engine coolant and lubricant are full. Spare tire, jack, hand tools and mats are in designated positions.

#### FOR CANADA MODELS

Item		Standard	
Camber Degree minute (Decimal degree)	Minimum	-1° 11' (-1.18°)	
	Nominal	-0° 41' (-0.68°)	
	Maximum	-0° 11' (-0.18°)	
Toe-in	Total toe-in Distance	Minimum	In 0.9 mm (0.035 in)
		Nominal	In 2.7 mm (0.106 in)
		Maximum	In 4.5 mm (0.177 in)
	Total toe-angle Degree minute (Decimal degree)	Minimum	In 0° 04' (In 0.07°)
		Nominal	In 0° 12' (In 0.20°)
		Maximum	In 0° 20' (In 0.33°)

Measure value under unladen\* conditions.

\*: Fuel, engine coolant and lubricant are full. Spare tire, jack, hand tools and mats are in designated positions.

### Ball Joint

INFOID:000000009721450

Item	Standard
Swing torque	0.5 – 3.4 N·m (0.06 – 0.34 kg-m, 5 – 30 in-lb)
Measurement on spring balance (cotter pinhole position)	8.1 – 54.8 N (0.83 – 5.6 kg, 1.82 – 12.32 lb)
Axial end play	0 mm (0 in)

### Wheelarch Height

INFOID:000000009721451

#### FOR USA MODELS

# SERVICE DATA AND SPECIFICATIONS (SDS)

## < SERVICE DATA AND SPECIFICATIONS (SDS)

Item	Standard					
	2WD			AWD		
Axle type						
Wheel size	18 inch		20 inch	18 inch		20 inch
Grade	S	SL	LE	S	SL	LE
Front (Hr)	846 mm (33.31 in)		845 mm (33.27 in)	846 mm (33.31 in)		845 mm (33.27 in)
Rear (Hr)	859 mm (33.82 in)	858 mm (33.78 in)		858 mm (33.78 in)		857 mm (33.74 in)

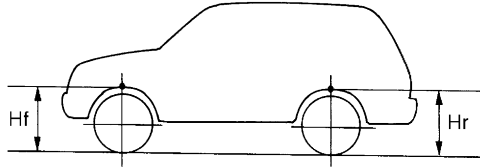

SFA746B

Measure value under unladen\* conditions.

\*: Fuel, engine coolant and lubricant are full. Spare tire, jack, hand tools and mats are in designated positions.

### FOR CANADA MODELS

Item	Standard		
	Wheel size	18 inch	
Grade	S	SL	LE
Front (Hr)	845 mm (33.27 in)		846 mm (33.31 in)
Rear (Hr)	858 mm (33.78 in)	857 mm (33.74 in)	

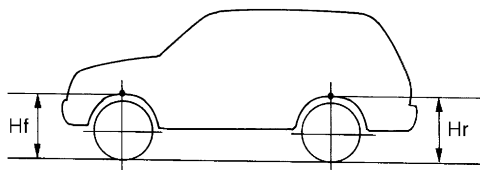

SFA746B

Measure value under unladen\* conditions.

\*: Fuel, engine coolant and lubricant are full. Spare tire, jack, hand tools and mats are in designated positions.

### FOR MEXICO MODELS

Item	Standard		
	Axle type	2WD	
Grade	S	SL	LE
Front (Hr)	846 mm (33.31 in)		845 mm (33.27 in)

# SERVICE DATA AND SPECIFICATIONS (SDS)

## < SERVICE DATA AND SPECIFICATIONS (SDS)

Item	Standard		
Axle type	2WD		AWD
Grade	S	SL	LE
Rear (Hr)	859 mm (33.82 in)	858 mm (33.78 in)	857 mm (33.74 in)

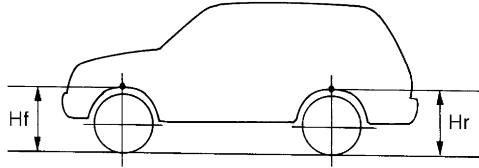

SFA746B

Measure value under unladen\* conditions.

\*: Fuel, engine coolant and lubricant are full. Spare tire, jack, hand tools and mats are in designated positions.