

SECTION **EM**

ENGINE MECHANICAL

CONTENTS

PRECAUTION	3	AIR CLEANER FILTER	17	A
PRECAUTIONS	3	Exploded View	17	
Precaution for Supplemental Restraint System (SRS) "AIR BAG" and "SEAT BELT PRE-TENSIONER"	3	Removal and Installation	17	EM
Precaution for Drain Coolant and Engine Oil	3	SPARK PLUG	18	
Precaution for Procedure without Cowl Top Cover.....	3	Exploded View	18	
Parts Requiring Angular Tightening	3	Removal and Installation	18	G
Precaution for Disconnecting Fuel Piping	4	CAMSHAFT VALVE CLEARANCE	20	
Precaution for Inspection, Repair and Replacement	4	Valve Clearance	20	H
Precaution for Removal and Disassembly	4	COMPRESSION PRESSURE	24	
Precaution for Assembly and Installation	4	On-Vehicle Service	24	I
Special Cautions to Ensure the Safe Disposal of Sodium-filled Exhaust Valves	4	REMOVAL AND INSTALLATION	25	J
Precaution for Liquid Gasket	5	ENGINE ROOM COVER	25	
PREPARATION	7	Exploded View	25	K
PREPARATION	7	Removal and Installation	25	
Special Service Tools	7	AIR CLEANER AND AIR DUCT	26	L
Commercial Service Tool	8	Exploded View	26	
SYSTEM DESCRIPTION	12	Removal and Installation	26	
NOISE, VIBRATION, AND HARSHNESS (NVH) TROUBLESHOOTING	12	INTAKE MANIFOLD COLLECTOR	28	M
NVH Troubleshooting - Engine Noise	12	Exploded View	28	
Use the Chart Below to Help You Find the Cause of the Symptom	13	Removal and Installation	28	
PERIODIC MAINTENANCE	14	INTAKE MANIFOLD	31	N
DRIVE BELT	14	Exploded View	31	
Exploded View	14	Removal and Installation	31	
Checking Drive Belt	14	EXHAUST MANIFOLD AND THREE WAY CATALYST	33	O
Tension Adjustment	14	Exploded View	33	
Removal and Installation	14	Removal and Installation (bank 2)	33	
Removal and Installation of Drive Belt Auto-tensioner	16	Removal and Installation (bank 1)	35	P
		OIL PAN AND OIL STRAINER	38	
		Exploded View	38	
		Removal and Installation (Lower Oil Pan)	38	
		Removal and Installation (Upper Oil Pan)	39	

IGNITION COIL	44	Disassembly and Assembly	94
Exploded View	44	Inspection After Disassembly	96
Removal and Installation (bank 2)	44		
Removal and Installation (bank 1)	44		
ROCKER COVER	45	ENGINE MOUNT	101
Exploded View	45	ENGINE MOUNT (FRONT)	101
Removal and Installation (bank 2)	45	ENGINE MOUNT (FRONT) : Removal and Instal-	
Removal and Installation (bank 1)	47	lation	101
FUEL INJECTOR AND FUEL TUBE	49	UNIT REMOVAL AND INSTALLATION ...	104
Exploded View	49	ENGINE ASSEMBLY	104
Removal and Installation	49	FWD	104
Inspection	53	FWD : Exploded View	104
VALVE TIMING CONTROL	54	FWD : Removal and Installation	104
Exploded View	54	AWD	108
Valve Timing Control Cover (bank 1)	54	AWD : Exploded View	108
Valve Timing Control Cover (bank 2)	55	AWD : Removal and Installation	109
FRONT TIMING CHAIN CASE	57	UNIT DISASSEMBLY AND ASSEMBLY ..	113
Exploded View	57	CYLINDER BLOCK	113
Removal and Installation	57	Exploded View	113
TIMING CHAIN	65	Disassembly and Assembly	114
Exploded View	65	Inspection	124
Removal and Installation	65	Dowel Pin Alignment	134
REAR TIMING CHAIN CASE	73	SERVICE DATA AND SPECIFICATIONS	
Exploded View	73	(SDS)	136
Removal and Installation	73	SERVICE DATA AND SPECIFICATIONS	
CAMSHAFT	78	(SDS)	136
Exploded View	78	General Specification	136
Removal and Installation	78	Drive Belt	136
Inspection after Installation	86	Spark Plug	137
OIL SEAL	87	Intake Manifold	137
Removal and Installation of Valve Oil Seal	87	Exhaust Manifold	137
Removal and Installation of Front Oil Seal	87	Camshaft	137
Removal and Installation of Rear Oil Seal	89	Cylinder Head	139
CYLINDER HEAD	91	Cylinder Block	142
Exploded View	91	Main Bearing	145
Removal and Installation	91	Connecting Rod Bearing	146
		Drive Plate	147

PRECAUTIONS

< PRECAUTION >

PRECAUTION

PRECAUTIONS

Precaution for Supplemental Restraint System (SRS) "AIR BAG" and "SEAT BELT PRE-TENSIONER"

INFOID:000000011536741

The Supplemental Restraint System such as "AIR BAG" and "SEAT BELT PRE-TENSIONER", used along with a front seat belt, helps to reduce the risk or severity of injury to the driver and front passenger for certain types of collision. Information necessary to service the system safely is included in the SR and SB section of this Service Manual.

WARNING:

- To avoid rendering the SRS inoperative, which could increase the risk of personal injury or death in the event of a collision which would result in air bag inflation, all maintenance must be performed by an authorized NISSAN/INFINITI dealer.
- Improper maintenance, including incorrect removal and installation of the SRS, can lead to personal injury caused by unintentional activation of the system. For removal of Spiral Cable and Air Bag Module, see the SR section.
- Do not use electrical test equipment on any circuit related to the SRS unless instructed to in this Service Manual. SRS wiring harnesses can be identified by yellow and/or orange harnesses or harness connectors.

PRECAUTIONS WHEN USING POWER TOOLS (AIR OR ELECTRIC) AND HAMMERS

WARNING:

- When working near the Airbag Diagnosis Sensor Unit or other Airbag System sensors with the Ignition ON or engine running, DO NOT use air or electric power tools or strike near the sensor(s) with a hammer. Heavy vibration could activate the sensor(s) and deploy the air bag(s), possibly causing serious injury.
- When using air or electric power tools or hammers, always switch the Ignition OFF, disconnect the battery and wait at least three minutes before performing any service.

Precaution for Drain Coolant and Engine Oil

INFOID:000000011220614

- Drain engine coolant and engine oil after the engine has cooled completely.

Precaution for Procedure without Cowl Top Cover

INFOID:000000011220613

When performing the procedure after removing cowl top cover, cover the lower end of windshield with urethane, etc to prevent damage to windshield.

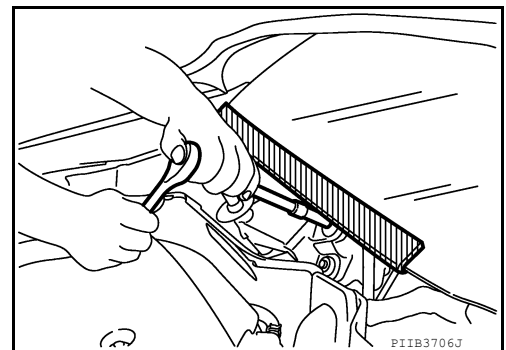

Parts Requiring Angular Tightening

INFOID:000000011220619

- Use an angle wrench for the final tightening of the following engine parts:
 - Cylinder head bolts
 - Main bearing cap bolts
 - Connecting rod cap nuts
 - Crankshaft pulley bolt (No angle wrench is required as the bolt flange is provided with notches for angular tightening)
- Do not use a torque value for final tightening.
- The torque value for these parts are for a preliminary step.
- Ensure thread and seat surfaces are clean and coated with engine oil.

PRECAUTIONS

< PRECAUTION >

Precaution for Disconnecting Fuel Piping

INFOID:0000000011220615

- Before starting work, make sure no fire or spark producing items are in the work area.
- Release fuel pressure before disassembly.
- After disconnecting pipes, plug openings to stop fuel leaks.

Precaution for Inspection, Repair and Replacement

INFOID:0000000011220617

- Thoroughly inspect parts before repairing or replacing them, even if they are new. Replace as necessary.

Precaution for Removal and Disassembly

INFOID:0000000011220616

- When instructed to use special service tools, use the specified tools. Always be careful to work safely, avoid forceful or uninstructed operations.
- Exercise maximum care to avoid damage to mating or sliding surfaces.
- Cover openings of engine system with tape or the equivalent, if necessary, to seal out foreign materials.
- Mark and arrange disassembly parts in an organized way for easy troubleshooting and assembly.
- When loosening nuts and bolts, as a basic rule, start with the one furthest outside, then the one diagonally opposite, and so on. If the order of loosening is specified, do exactly as specified. Power tools may be used where noted in the step.

Precaution for Assembly and Installation

INFOID:0000000011220618

- Use torque wrench to tighten bolts or nuts to specification.
- When tightening nuts and bolts, as a basic rule, equally tighten in several different steps starting with the ones in center, then ones on inside and outside diagonally in this order. If the order of tightening is specified, do exactly as specified.
- Replace with new gasket, packing, oil seal or O-ring.
- Dowel pins are used in several critical parts for correct alignment. When replacing and reassembling parts with dowel pins, check that dowel pins are installed in their original positions.
- Thoroughly wash, clean, and air-blow each part. Carefully check oil or coolant passages for any restriction and blockage.
- Avoid damaging sliding or mating surfaces. Completely remove foreign materials such as cloth lint or dust. Before assembly, oil sliding surfaces well.
- Release air within route when refilling after draining coolant.
- Before starting engine, apply fuel pressure to fuel lines with turning ignition switch ON (with engine stopped). Then make sure that there are no leaks at fuel line connections.
- After repairing, start engine and increase engine speed to check coolant, fuel, oil, and exhaust systems for leaks.

Special Cautions to Ensure the Safe Disposal of Sodium-filled Exhaust Valves

INFOID:0000000011536743

Handling and disposal of sodium-filled exhaust valves requires special care and consideration. Under conditions such as breakage with subsequent contact with water, metal sodium which lines the inner portion of exhaust valve will react violently, forming sodium hydroxide and hydrogen which may result in an explosion. Sodium-filled exhaust valve is identified on the top of its stem as shown in illustration.

(A) : Identification mark of sodium-filled exhaust valve

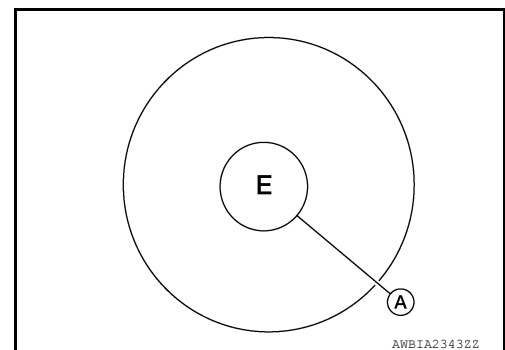

DEALER DISPOSAL INSTRUCTIONS

CAUTION:

- Use approved shatter-resistant eye protection when performing this procedure.
- Perform this and all subsequent disposal work procedures in an open room, away from flammable liquids. Keep a fire extinguisher, rated at least 10 ABC, in close proximity to the work area.
- Be sure to wear rubber gloves when performing the following operations.
- Make sure the resultant (high alkalinity) waste water does not contact your skin. If the waste water does contact you, wash the contacted area immediately with large quantities of water.

PRECAUTIONS

< PRECAUTION >

- Dealers should check their respective state and local regulations concerning any chemical treatment or waste water discharge permits which may be required to dispose of the resultant (high alkalinity) waste water.

1. Clamp valve stem in a vice.
2. The valve has a specially-hardened surface. To cut through it, first remove a half-round section, approximately 30 mm (1.18 in) long using air-powered grinder until black color is removed and silver color appears.

- (A) : Black color
- (B) : Silver color
- (c) : 47 mm (1.85 in)
- (d) : 17 mm (0.67 in)

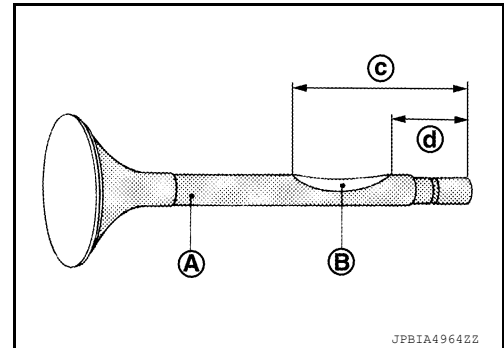

3. Use hacksaw to cut through approximately half the diameter of valve stem. Make the serration at a point 40 mm (1.57 in) from the end of valve stem.

- (a) : 40 mm (1.57 in)

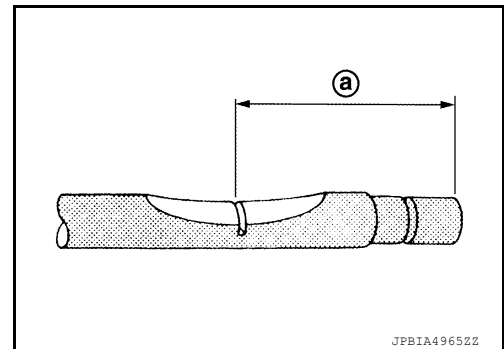

4. Cover the serrated end of the valve with a large shop towel (A). Strike the valve face end with a hammer, separating it into two pieces.
5. Fill a bucket, such as a 20 ℓ (5-1/4 US gal, 4-3/8 Imp gal) oil can, with at least 10 ℓ (2-5/8 US gal, 2-1/4 Imp gal) of water. Carefully place the already cut (serrated) valves into the water one-at-a-time using a set of large tweezers and quickly move away at least 2.7 m (9 ft).

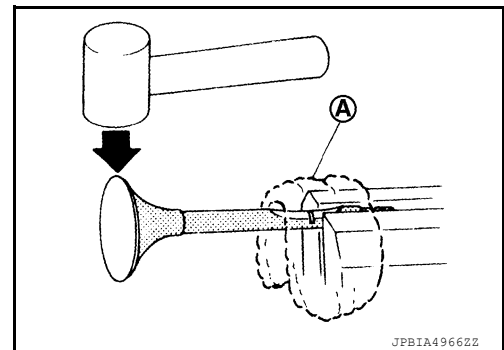

6. The valves should be placed in a standing position as shown in the illustration to allow complete reaction. After the bubbling action has subsided, additional valves can be placed into the bucket allowing each subsequent chemical reaction to subside. However, no more than eight valves should be placed in the same 10 ℓ (2-5/8 US gal, 2-1/4 Imp gal) amount of water. The complete chemical reaction may take as long as four to five hours. Remove the valves using a set of large tweezers after the chemical reaction has stopped. Afterwards, valves can be disposed as ordinary scrap.

- (A) : Bucket [Such as 20 ℓ (5-1/4 US gal, 4-3/8 Imp gal) oil can]

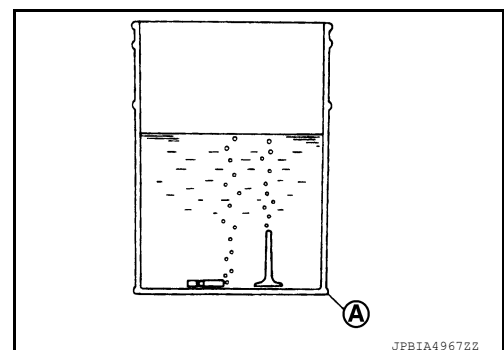

Precaution for Liquid Gasket

INFOID:000000011607899

REMOVAL OF LIQUID GASKET SEALING

PRECAUTIONS

< PRECAUTION >

- After removing the bolts and nuts, separate the mating surface and remove the liquid gasket using Tool (A).

Tool Number : KV10111100 (J-37228)

CAUTION:

Be careful not to damage the mating surfaces.

- In areas where the cutter is difficult to use, use a plastic hammer to lightly tap (1) the cutter where the liquid gasket is applied. Use a plastic hammer to slide (2) the cutter by tapping on the side.

CAUTION:

Do not damage the mating surfaces.

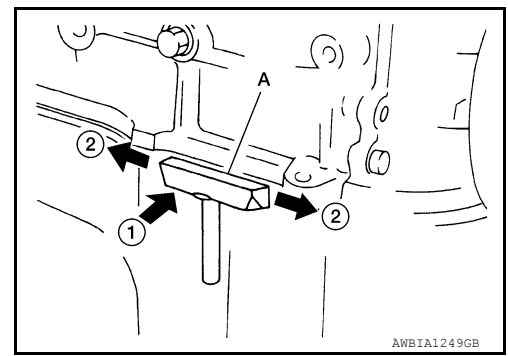

LIQUID GASKET APPLICATION PROCEDURE

1. Using suitable tool (A), remove old liquid gasket adhering to the liquid gasket application surface and the mating surface.
 - Remove liquid gasket completely from the groove of the liquid gasket application surface, mounting bolts, and bolt holes.
2. Thoroughly clean the mating surfaces and remove adhering moisture, grease and foreign materials.

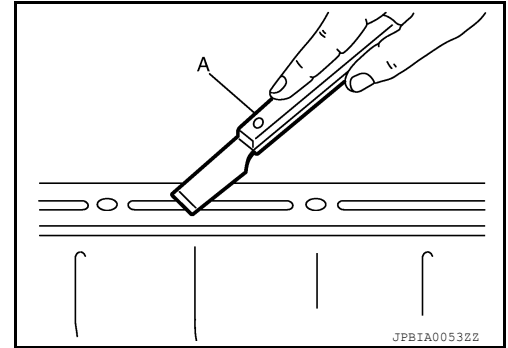

3. Attach liquid gasket tube to the suitable tool.
Use Genuine Silicone RTV Sealant, or equivalent. Refer to [GI-22, "Recommended Chemical Products and Sealants"](#).
4. Apply liquid gasket without gaps to the specified location according to the specified dimensions.
 - If there is a groove for liquid gasket application, apply liquid gasket to the groove.

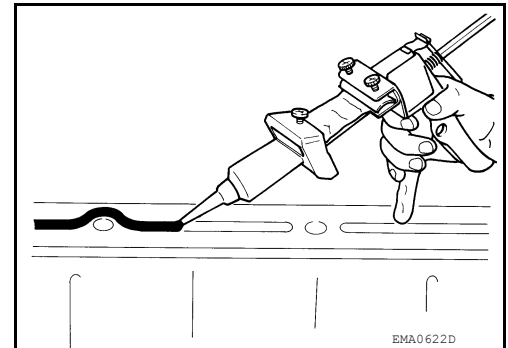

- As for bolt holes (B), normally apply liquid gasket inside the holes. Occasionally, it should be applied outside the holes. Check to read the text of this manual.

(A) : Groove

↔ : Inside

- Within five minutes of liquid gasket application, install the mating component.
- If liquid gasket protrudes, wipe it off immediately.
- Do not retighten mounting bolts or nuts after the installation.
- After 30 minutes or more have passed from the installation, fill engine oil and engine coolant. Refer to [LU-9, "Changing Engine Oil"](#) and [CO-9, "Changing Engine Coolant"](#).

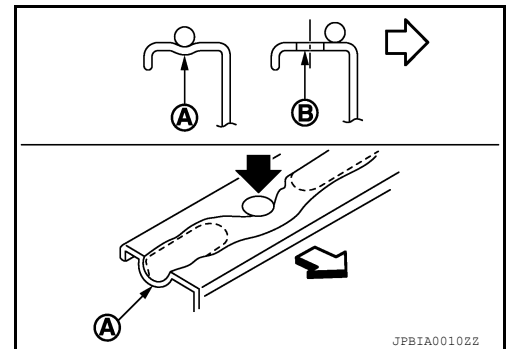

CAUTION:

If there are more specific instructions in the procedures contained in this manual concerning liquid gasket application, observe them.

PREPARATION

< PREPARATION >

PREPARATION

PREPARATION



Special Service Tools

INFOID:000000011538118

A

EM

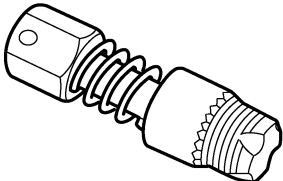
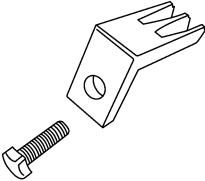
The actual shape of the tools may differ from those illustrated here.

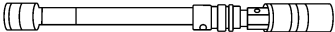
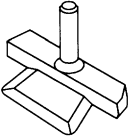
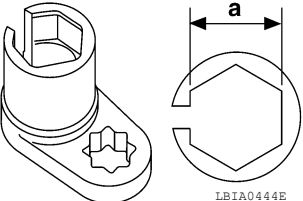
Tool number (TechMate No.) Tool name	Description
(J-43897-18) Oxygen sensor thread cleaner  AWBIA2076ZZ	Reconditioning the exhaust system threads before installing a new oxygen sensor (Use with anti-seize lubricant shown below.) J-43897-18 (18 mm dia.) for zirconia oxygen sensor
— (J-50288) Ring gear stopper  ALBIA0675ZZ	Removing and installing crankshaft pulley
16441 6N210 (J-45488) Quick connector release  PBIC0198E	Removing fuel tube quick connectors in engine room (Available in SEC. 164 of PARTS CATALOG: Part No. 16441 6N210)
— (J-48891) Spark plug socket  AWBIA1785ZZ	Removing and installing spark plug
KV10111100 (J-37228) Seal cutter  S-NT046	Removing oil pan and timing chain case
KV991J0050 (J-44626) Air fuel sensor Socket  LBIA0444E	Loosening or tightening air fuel ratio A/F sensor a: 22 mm (0.87 in)

C

D

E

F

G

H

I

J

K

L

M

N

O

P

PREPARATION

< PREPARATION >

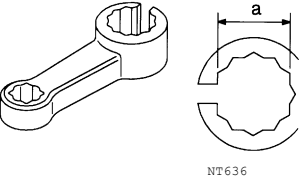
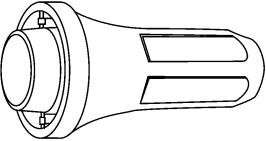
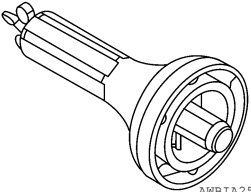
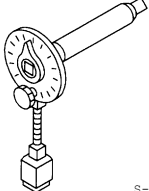
Tool number (TechMate No.) Tool name	Description
KV10114400 (J-38365) Heated oxygen sensor wrench 	Loosening or tightening rear heated oxygen sensor a: 22 mm (0.87 in)
— (J-37066) Seal installer 	Installing front main seal
— (J-47128) Seal installer 	Installing rear main seal
KV10112100 (BT-8653-A) Torque angle meter 	Tightening bolts for bearing cap, cylinder head, etc.

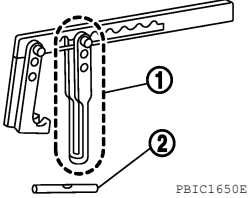
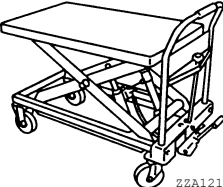

Commercial Service Tool

INFOID:0000000011538119

Tool number (TechMate No.) Tool name	Description
KV10116200 (J-26336-A) Valve spring compressor 1. KV10115900 (J-26336-20) Attachment 2. KV10109220 (—) Adapter 	Disassembling valve mechanism Part (1) is a component of KV10116200 (J-26336-A), but part (2) is not.
Manual lift table caddy 	Removing and installing engine

PREPARATION

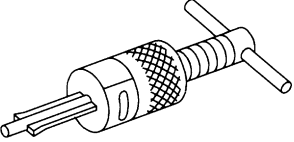
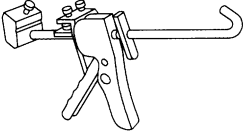
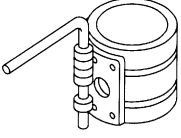
< PREPARATION >

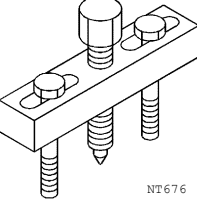
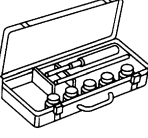
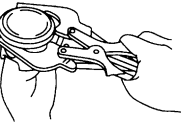
Tool number (TechMate No.) Tool name	Description	A
ST16610001 (J-23907) Pilot converter puller  S-NT045	Removing crankshaft pilot converter	EM
Tube presser  S-NT052	Pressing the tube of liquid gasket	C D
Piston ring compressor  S-NT044	Installing piston assembly into cylinder bore	E F G
Pulley holder  ZZA1010D	Crankshaft pulley removing and installing	H I J
Pulley puller  NT676	Removing crankshaft pulley	K L M
Valve seat cutter set  S-NT048	Finishing valve seat dimensions	N O
Piston ring expander  S-NT030	Removing and installing piston ring	P

PREPARATION

< PREPARATION >

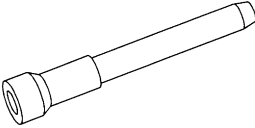
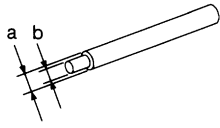
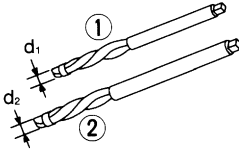
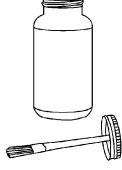
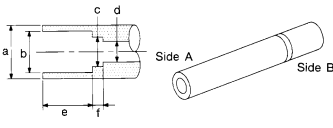
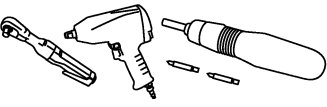
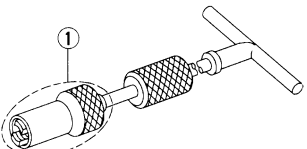
Tool number (TechMate No.) Tool name	Description
<p>— (J-39386) Valve oil seal drift</p>  <p style="text-align: center;">NT024</p>	<p>Installing valve oil seal</p>
<p>Valve guide drift</p>  <p style="text-align: center;">S-NT015</p>	<p>Removing and installing valve guide Intake & Exhaust: a: 9.5 mm (0.374 in) dia. b: 5.5 mm (0.217 in) dia.</p>
<p>Valve guide reamer</p>  <p style="text-align: center;">S-NT016</p>	<p>1: Reaming valve guide inner hole 2: Reaming hole for oversize valve guide Intake & Exhaust: d1: 6.0 mm (0.236 in) dia. d2: 10.2 mm (0.402 in) dia.</p>
<p>Anti-seize lubricant (Permatex 133AR or equivalent meeting MIL specification MIL-A-907)</p>  <p style="text-align: center;">AEM489</p>	<p>Lubricating oxygen sensor thread cleaning tool when reconditioning exhaust system threads</p>
<p>KV10115600 (J-38958) Valve oil seal drift</p>  <p style="text-align: center;">S-NT603</p>	<p>Installing valve oil seal Use side A. a: 20 (0.79) dia. d: 8 (0.31) dia. b: 13 (0.51) dia. e: 10.7 (0.421) dia. c: 10.3 (0.406) dia. f: 5 (0.20) dia. Unit: mm (in)</p>
<p>Power tool</p>  <p style="text-align: center;">PIIB1407E</p>	<p>Loosening nuts, screws, and bolts</p>
<p>KV10107902 (J-38959) Valve oil seal puller with adapter (1)</p>  <p style="text-align: center;">S-NT605</p>	<p>Removing valve oil seal</p>

PREPARATION

< PREPARATION >

Tool number (TechMate No.) Tool name	Description	A
ST0501S000 Engine stand assembly (—) 1. ST05011000 (—) Engine stand 2. ST05012000 (—) Base	Disassembling and assembling	EM C
KV10106500 (—) Engine stand shaft	Engine supporting	D E F
KV10115300 (—) Engine sub-attachment	Disassembling and assembling	G H
(J-45816) E20 ®Socket	Removing and installing CVT drive plate bolts	I J K

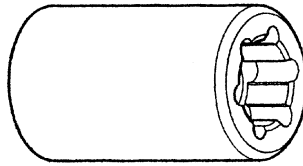
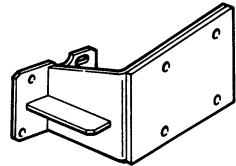
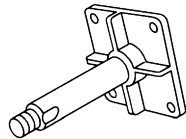
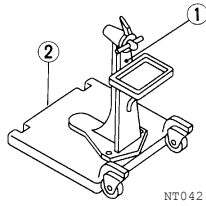

NOISE, VIBRATION, AND HARSHNESS (NVH) TROUBLESHOOTING

< SYSTEM DESCRIPTION >

SYSTEM DESCRIPTION

NOISE, VIBRATION, AND HARSHNESS (NVH) TROUBLESHOOTING

NVH Troubleshooting - Engine Noise

INFOID:000000011220623

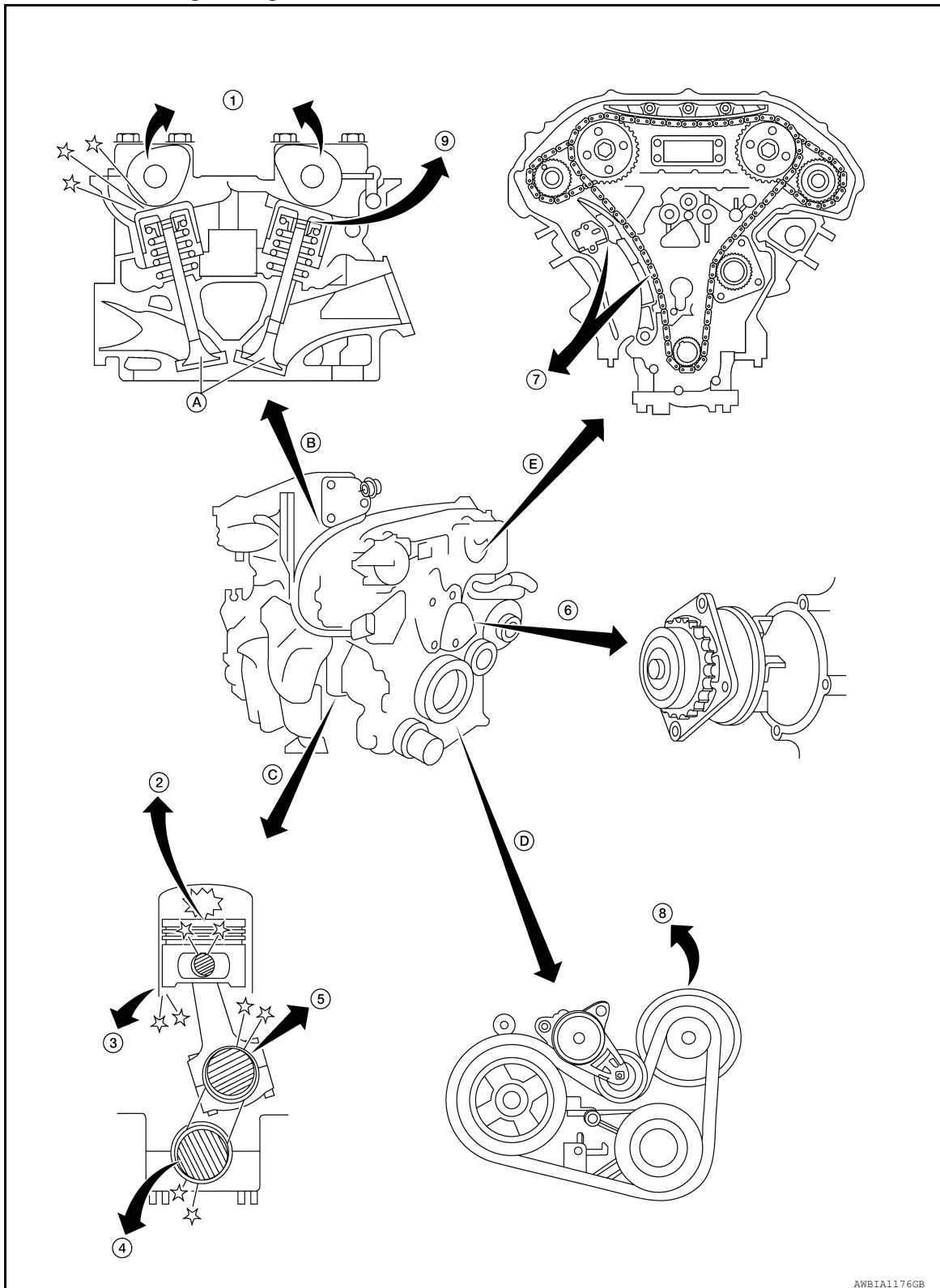

AWBIA1176GB

- | | | |
|---------------------------|---------------------------------|----------------------|
| 1. Camshaft bearing noise | 2. Piston pin noise | 3. Piston slap noise |
| 4. Main bearing noise | 5. Connecting rod bearing noise | 6. Water pump noise |

NOISE, VIBRATION, AND HARSHNESS (NVH) TROUBLESHOOTING

< SYSTEM DESCRIPTION >

- | | | |
|---|---|-----------------------|
| 7. Timing chain and chain tensioner noise | 8. Drive belt noise (Sticking/Slipping) | 9. Tappet noise |
| A. Valve | B. Valve mechanism | C. Rotation mechanism |
| D. Drive belt | E. Timing chain | |

A

EM

Use the Chart Below to Help You Find the Cause of the Symptom

INFOID:000000011220624

1. Locate the area where noise occurs.
2. Confirm the type of noise.
3. Specify the operating condition of engine.
4. Check specified noise source. Repair or replace the identified part as necessary.

C

D

Location of noise	Type of noise	Operating condition of engine						Source of noise	Check item	Reference page
		Before warm-up	After warm-up	When starting	When idling	When racing	While driving			
Top of engine Rocker cover Cylinder head	Ticking or clicking	C	A	—	A	B	—	Tappet noise	Valve clearance	EM-20
	Rattle	C	A	—	A	B	C	Camshaft bearing noise	Camshaft journal clearance Camshaft runout	EM-137
Crankshaft pulley Cylinder block (Side of engine) Oil pan	Slap or knock	—	A	—	B	B	—	Piston pin noise	Piston and piston pin clearance Connecting rod bushing clearance	EM-24
	Slap or rap	A	—	—	B	B	A	Piston slap noise	Piston-to-bore clearance Piston ring side clearance Piston ring end gap Connecting rod bend and torsion	EM-142
	Knock	A	B	C	B	B	B	Connecting rod bearing noise	Connecting rod bushing clearance (Small end) Connecting rod bearing clearance (Big end)	EM-146
	Knock	A	B	—	A	B	C	Main bearing noise	Main bearing oil clearance Crankshaft runout	EM-145
Front of engine Timing chain cover	Tapping or ticking	A	A	—	B	B	B	Timing chain and chain tensioner noise	Timing chain cracks and wear Timing chain tensioner operation	EM-65
Front of engine	Squeaking or fizzing	A	B	—	B	—	C	Drive belts (Sticking or slipping)	Drive belts deflection	EM-14
	Creaking	A	B	A	B	A	B	Drive belts (Slipping)	Idler pulley bearing operation	
	Squall Creak	A	B	—	B	A	B	Water pump noise	Water pump operation	CO-17

E

F

G

H

I

J

K

L

M

N

O

P

A: Closely related B: Related C: Sometimes related —: Not related

DRIVE BELT

< PERIODIC MAINTENANCE >

PERIODIC MAINTENANCE

DRIVE BELT

Exploded View

INFOID:0000000011220625

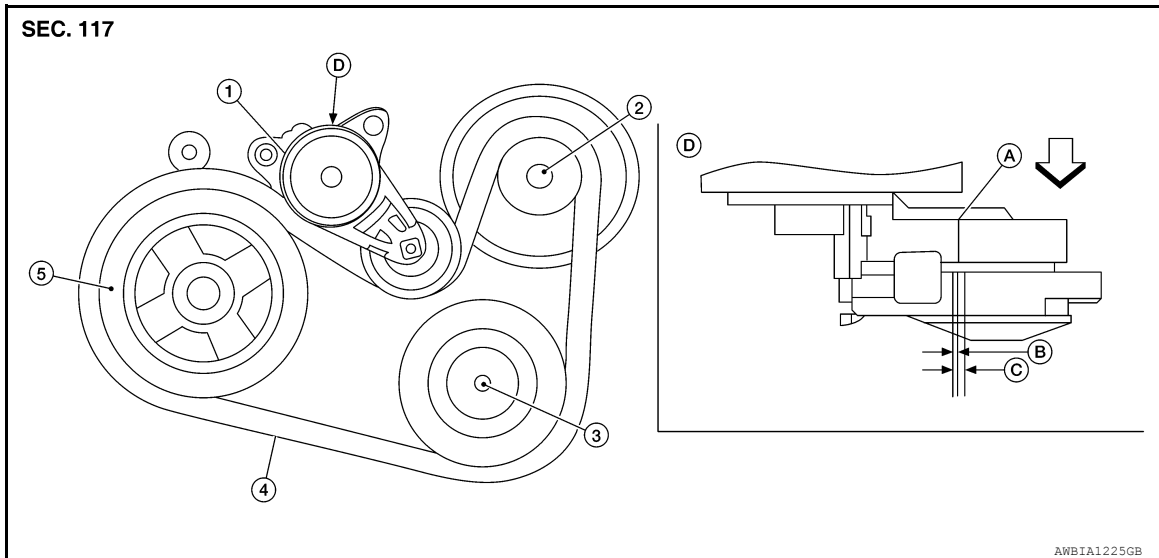

- | | | |
|---|-----------------------|-------------------|
| 1. Drive belt auto-tensioner | 2. Generator | 3. A/C compressor |
| 4. Drive belt | 5. Crankshaft pulley | A. Indicator |
| B. Range when new drive belt is installed | C. Possible use range | D. View D |
- ↶ Engine front

Checking Drive Belt

INFOID:0000000011220626

WARNING:

Inspect and check the drive belt with the engine off.

1. Inspect drive belt for cracks, wear, fraying, or oil adhesion. If necessary, replace with a new one.
2. Rotate the crankshaft pulley two times, then ensure the drive belt auto-tensioner is within the possible use range.
3. Visually check entire drive belt for wear, damage or cracks.
4. Check that the drive belt auto-tensioner indicator is within the possible use range.

NOTE:

- When new drive belt is installed, the drive belt auto-tensioner indicator should be within the new drive belt range.
 - Check the drive belt auto-tensioner indicator when the engine is cold.
5. If the drive belt auto-tensioner indicator is out of the possible use range or belt is damaged, replace drive belt.

Tension Adjustment

INFOID:0000000011220627

- Drive belt tension is automatically adjusted by the drive belt auto-tensioner.
- Drive belt tension is not manually adjustable.

Removal and Installation

INFOID:0000000011220628

REMOVAL

1. Remove the front wheel and tire (RH) using a power tool. Refer to [WT-68, "Removal and Installation"](#).
2. Remove the fender protector side cover (RH). Refer to [EXT-36, "FENDER PROTECTOR : Exploded View"](#).

DRIVE BELT

< PERIODIC MAINTENANCE >

3. While securely holding the hexagonal part in pulley center of drive belt auto-tensioner, move in the direction of arrow (loosening direction of drive belt auto-tensioner) using suitable tool.

WARNING:

Avoid placing hand in a location where pinching may occur if the holding tool accidentally comes off.

CAUTION:

Do not loosen the drive belt auto-tensioner pulley bolt. (Do not turn it counterclockwise. If turned counterclockwise, the complete drive belt auto-tensioner must be replaced as a unit, including pulley.)

4. Insert a rod approximately 6 mm (0.24 in) in diameter through the rear of drive belt auto-tensioner into retaining boss to lock drive belt auto-tensioner pulley.

NOTE:

Leave drive belt auto-tensioner pulley arm locked until belt is installed.

5. Remove drive belt from crankshaft pulley and then remove it from the other pulleys.

INSTALLATION

1. Install the drive belt onto all of the pulleys.

CAUTION:

Confirm belt is completely set on the pulleys.

2. Release drive belt auto-tensioner, and apply tension to drive belt.

WARNING:

Avoid placing hand in a location where pinching may occur if the holding tool accidentally comes off.

CAUTION:

Do not loosen the drive belt auto-tensioner pulley bolt. (Don't turn it counterclockwise. If turned counterclockwise, the complete drive belt auto-tensioner must be replaced as a unit, including pulley.)

3. Turn crankshaft pulley clockwise several times to equalize tension between each pulley.
4. Confirm drive belt auto-tensioner indicator is within the possible use range. Refer to [EM-14, "Checking Drive Belt"](#).
5. Install the fender protector side cover (RH). Refer to [EXT-36, "FENDER PROTECTOR : Exploded View"](#).
6. Install the front wheel and tire (RH). Refer to [WT-68, "Removal and Installation"](#).

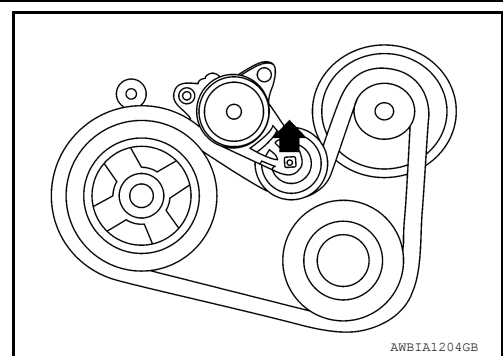

A

EM

C

D

E

F

G

H

I

J

K

L

M

N

O

P

DRIVE BELT

< PERIODIC MAINTENANCE >

Removal and Installation of Drive Belt Auto-tensioner

INFOID:000000011220629

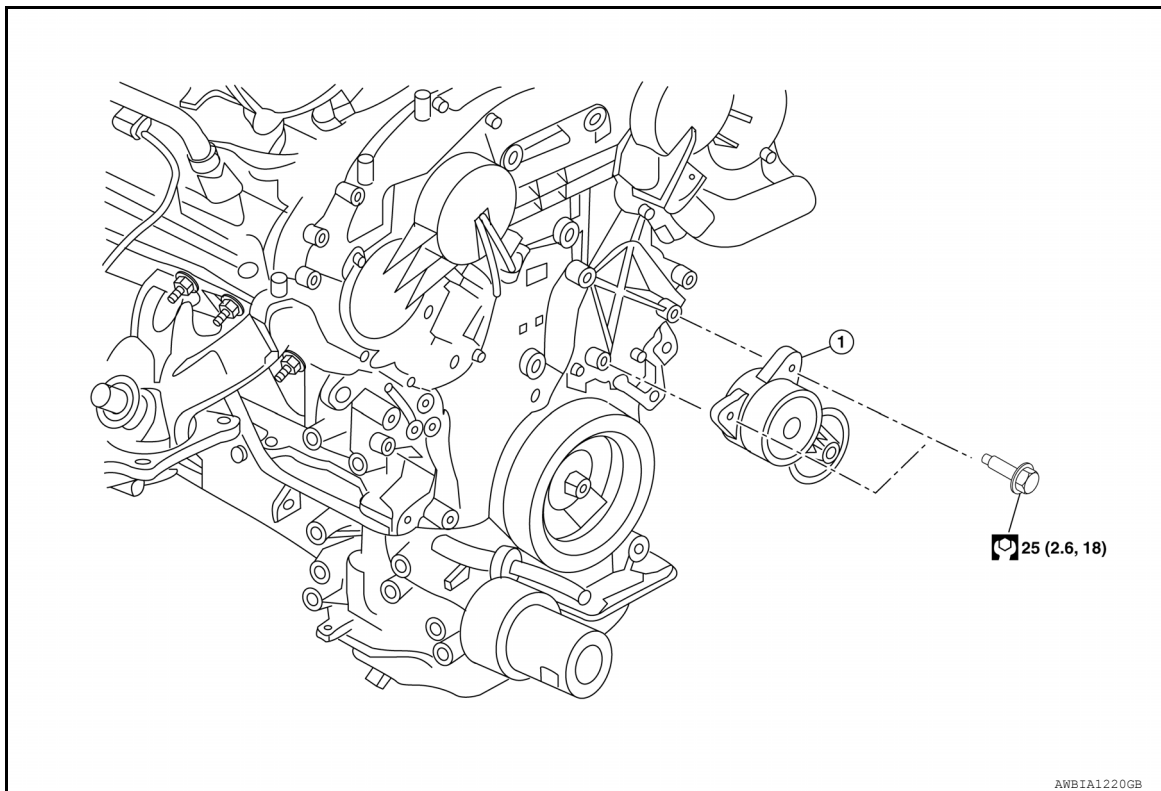

1. Drive belt auto-tensioner

REMOVAL

CAUTION:

The complete drive belt auto-tensioner must be replaced as a unit, including the pulley.

1. Remove the drive belt. Refer to [EM-14, "Removal and Installation"](#).
2. Remove the drive belt auto-tensioner.

CAUTION:

Do not loosen the drive belt auto-tensioner pulley bolt. (Don't turn it counterclockwise. If turned counterclockwise, the complete drive belt auto-tensioner must be replaced as a unit, including pulley).

INSTALLATION

Installation is in the reverse order of removal.

CAUTION:

- If there is damage greater than peeled paint, replace drive belt auto-tensioner.
- Do not swap the pulley between the new and old drive belt auto-tensioner.
- The complete drive belt auto-tensioner must be replaced as a unit, including the pulley.

AIR CLEANER FILTER

< PERIODIC MAINTENANCE >

AIR CLEANER FILTER

Exploded View

INFOID:000000011220630

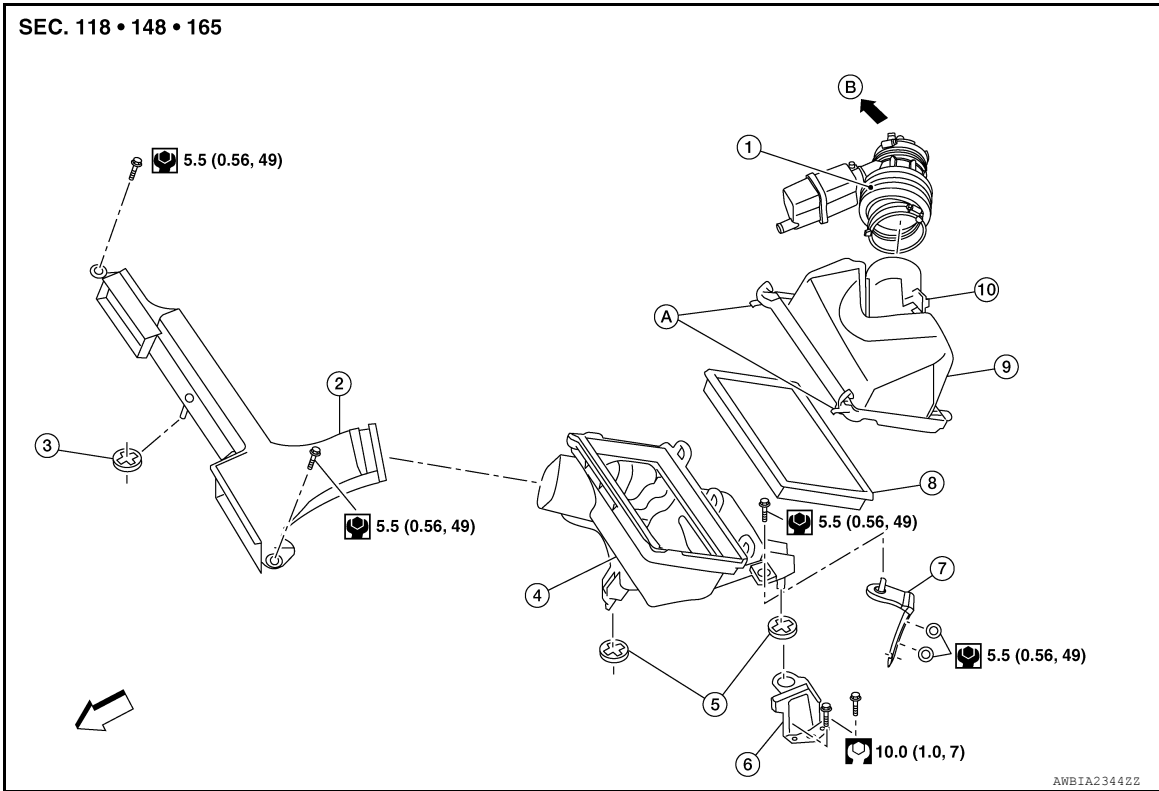

- | | | |
|---|--------------------------------|--|
| 1. Air duct hose and resonator assembly | 2. Front air duct | 3. Grommet |
| 4. Air cleaner case (lower) | 5. Grommets | 6. Air cleaner case mounting bracket |
| 7. Bracket | 8. Air cleaner filter | 9. Air cleaner case (upper) |
| 10. Mass air flow sensor | A. Air cleaner case side clips | B. To electric throttle control actuator clips |

↶ Front

Removal and Installation

INFOID:000000011220631

REMOVAL

CAUTION:

It is not necessary to remove the front air duct to replace the air cleaner filter.

NOTE:

Replace the air cleaner filter per the periodic maintenance schedule or as necessary. Refer to [MA-7. "Introduction of Periodic Maintenance"](#).

1. Unhook air cleaner case side clips and lift air cleaner case (upper).
2. Remove the air cleaner filter.

INSTALLATION

Installation is in the reverse order of removal.

SPARK PLUG

< PERIODIC MAINTENANCE >

SPARK PLUG

Exploded View

INFOID:000000011220632

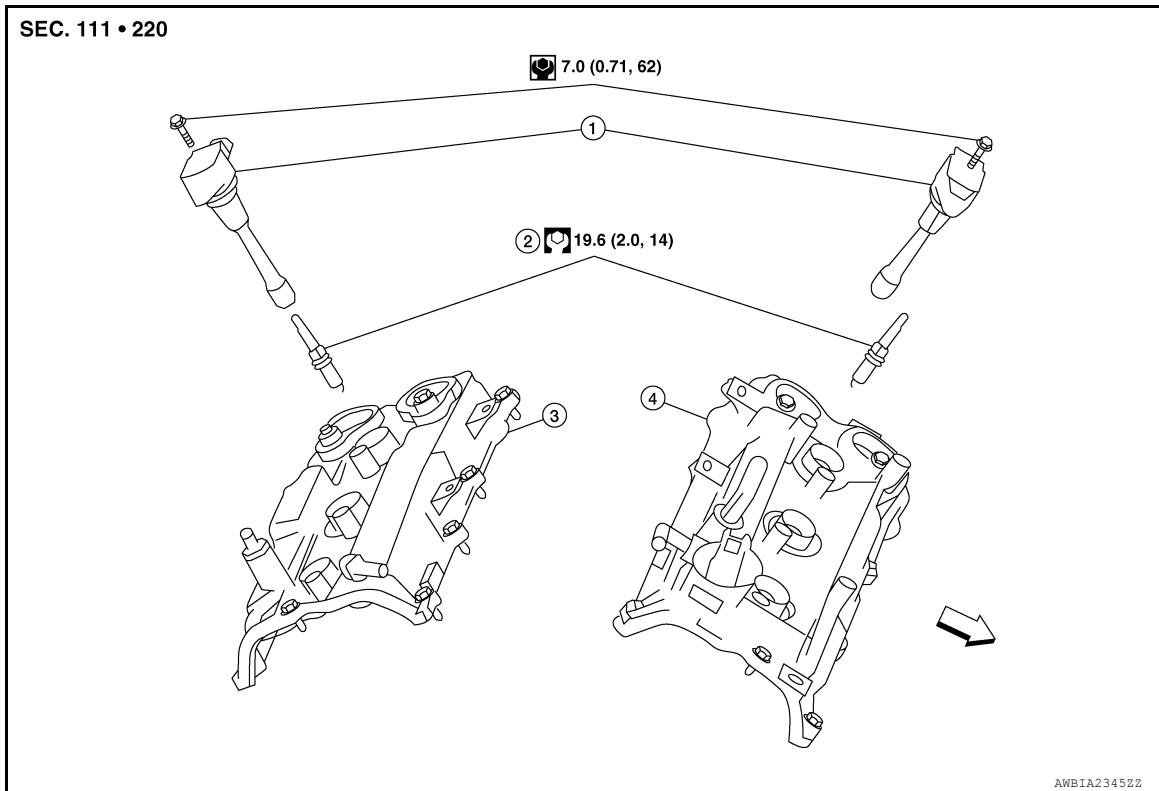

- 1. Ignition coil
 - 2. Spark plug
 - 3. Rocker cover (RH)
 - 4. Rocker cover (LH)
- ← Front

Removal and Installation

INFOID:000000011220633

REMOVAL

1. Remove the ignition coil. Refer to [EM-44. "Removal and Installation \(bank 2\)"](#) and [EM-44. "Removal and Installation \(bank 1\)"](#).
2. Remove the spark plug with a suitable spark plug wrench.

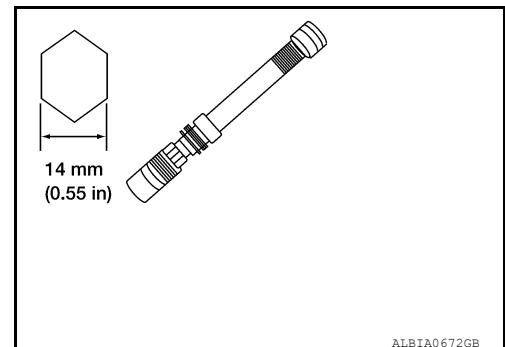

INSPECTION AFTER REMOVAL

SPARK PLUG

< PERIODIC MAINTENANCE >

Use the standard type spark plug for normal condition.

Spark plug : Refer to [EM-137, "Spark Plug"](#).

CAUTION:

- Do not drop or shock spark plug. Discard spark plug if dropped.
- Do not use a wire brush for cleaning.
- If plug is covered with carbon, a spark plug cleaner may be used.

Cleaner air pressure : less than 588 kPa (6 kg/cm², 85 psi)

Cleaning time : less than 20 seconds

- Spark plug gap adjustment is not required between replacement intervals.
- Measure spark plug gap. When it exceeds the limit, replace spark plug even if it is within the specified replacement mileage. Refer to [EM-137, "Spark Plug"](#).

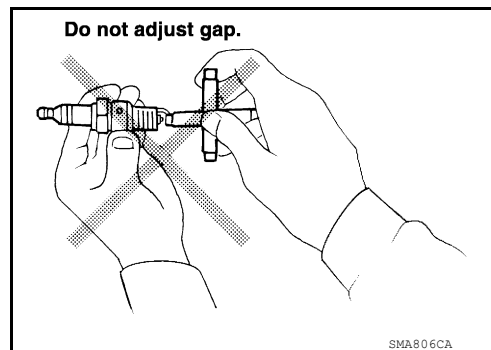
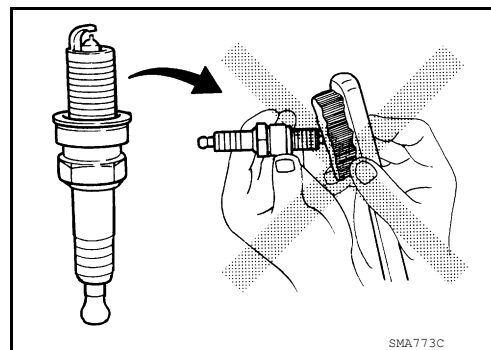

INSTALLATION

Installation is in the reverse order of removal.

Make	DENSO
Standard type*	FXE22HR11
Gap (nominal)	1.1 mm (0.043 in)

*: Always check with the Parts Department for the latest parts information.

A
EM
C
D
E
F
G
H
I
J
K
L
M
N
O
P

CAMSHAFT VALVE CLEARANCE

< PERIODIC MAINTENANCE >

CAMSHAFT VALVE CLEARANCE

Valve Clearance

INFOID:000000011220634

CHECKING

CAUTION:

Check valve clearance while engine is cold and not running.

NOTE:

Perform valve clearance inspection after removal, installation or replacement of camshaft or valve parts, or as necessary.

1. Remove the air duct with air cleaner case, collectors, hoses, wires, harnesses, and connectors. Refer to [EM-26. "Removal and Installation"](#).
2. Remove the intake manifold collector. Refer to [EM-28. "Removal and Installation"](#).
3. Remove the ignition coils and spark plugs. Refer to [EM-44. "Exploded View"](#).
4. Remove the rocker covers. Refer to [EM-45. "Exploded View"](#).
5. Set No.1 cylinder at TDC on its compression stroke.

⇐ : Engine front

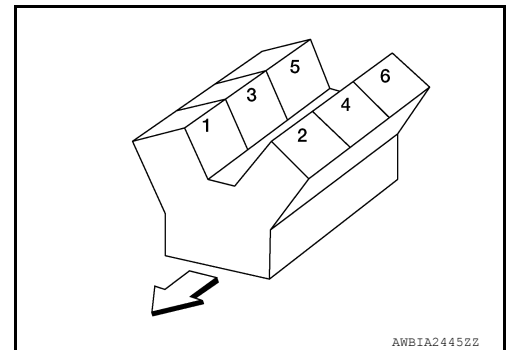

- a. Align pointer with TDC mark (A) on crankshaft pulley.

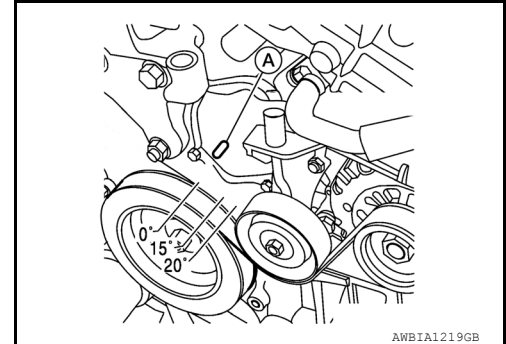

- b. Check that the valve lifters on No.1 cylinder, bank 1 (A) are loose and valve lifters on No.4 are tight. If not, turn the crankshaft one full revolution (360°) and align as shown.

⇐ : Engine front

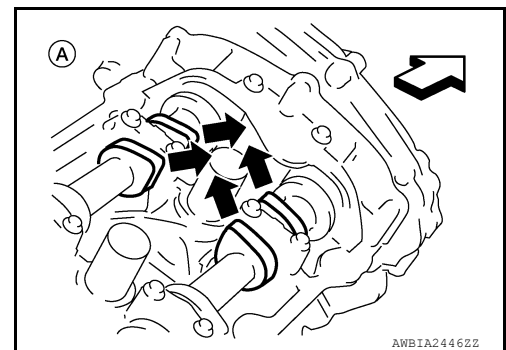

CAMSHAFT VALVE CLEARANCE

< PERIODIC MAINTENANCE >

6. Check only the valves as shown.

Crank Position	Valve No. 1	Valve No. 2	Valve No. 3	Valve No. 6
No. 1 TDC	Intake	Exhaust	Exhaust	Intake

- (A). : Bank 1 cylinder head
- (B). : Bank 2 cylinder head
- (C). : Bank 2 exhaust camshaft
- (D). : Bank 2 intake camshaft
- (E). : Bank 1 intake camshaft
- (F). : Bank 1 exhaust camshaft
- ← : Engine front

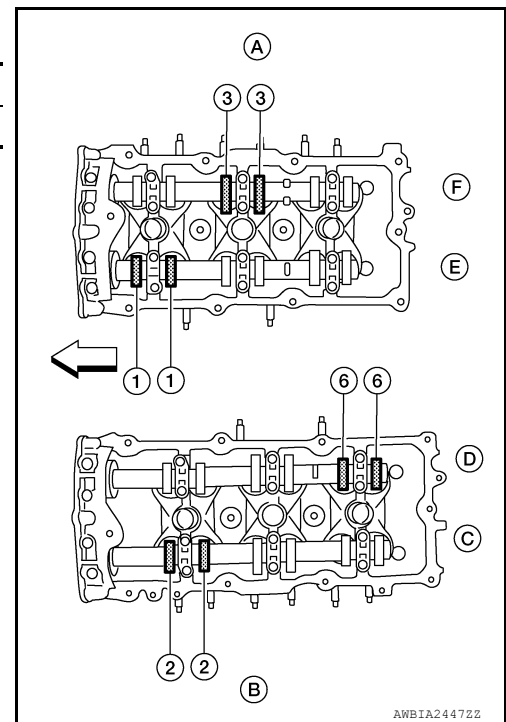

a. Using a feeler gauge, measure the clearance between the valve lifter and camshaft.

Valve clearance : Refer to [EM-136](#),
"General Specification".

b. Record any valve clearance measurements which are out of specification. They will be used later to determine the required replacement lifter size.

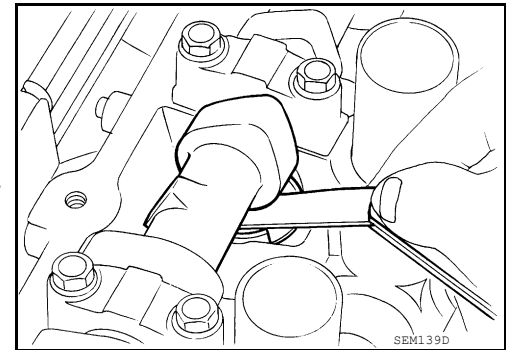

- (A). : Camshaft
- (B). : Valve lifter
- (C). : Suitable tool

7. Turn crankshaft 240°.

8. Set No.3 cylinder at TDC on its compression stroke.

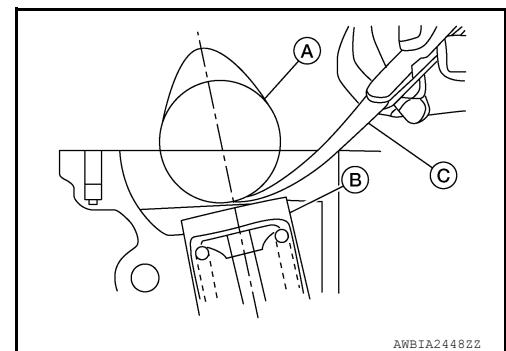

CAMSHAFT VALVE CLEARANCE

< PERIODIC MAINTENANCE >

9. Check only those valves as shown.

Crank Position	Valve No. 2	Valve No. 3	Valve No. 4	Valve No. 5
No. 3 TDC	Intake	Intake	Exhaust	Exhaust

- (A). : Bank 1 cylinder head
- (B). : Bank 2 cylinder head
- (C). : Bank 2 exhaust camshaft
- (D). : Bank 2 intake camshaft
- (E). : Bank 1 intake camshaft
- (F). : Bank 1 exhaust camshaft
- ⇐ : Engine front

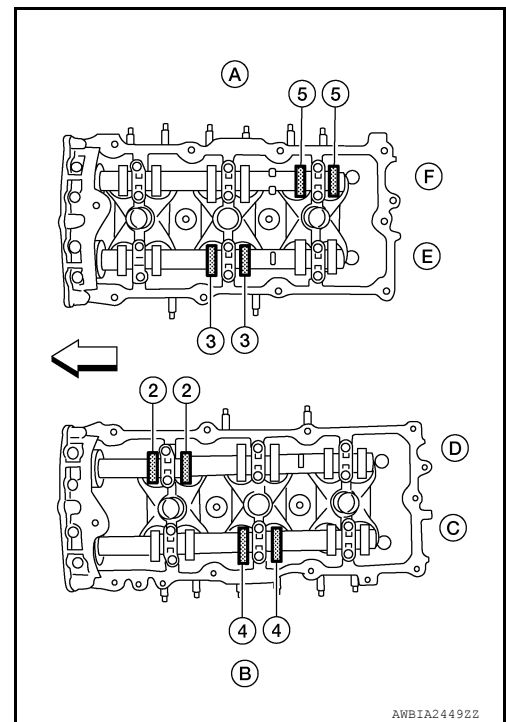

10. Turn the crankshaft 240° and align as above.

11. Set No.5 cylinder at TDC on its compression stroke.

12. Check only those valves as shown.

Crank Position	Valve No. 1	Valve No. 4	Valve No. 5	Valve No. 6
No. 5 TDC	Exhaust	Intake	Intake	Exhaust

- (A). : Bank 1 cylinder head
- (B). : Bank 2 cylinder head
- (C). : Bank 2 exhaust camshaft
- (D). : Bank 2 intake camshaft
- (E). : Bank 1 intake camshaft
- (F). : Bank 1 exhaust camshaft
- ⇐ : Engine front

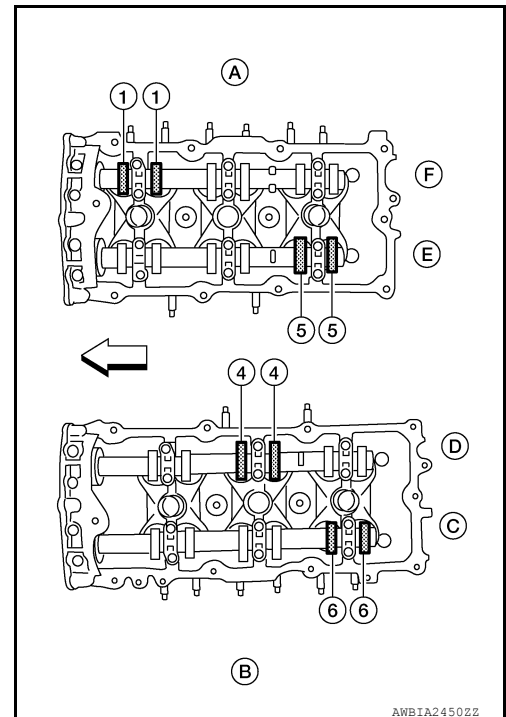

13. Perform adjustment if the measured values are out of the specification range.

14. Installation of components is in the reverse order of removal.

VALVE ADJUSTING

CAUTION:

Adjust valve clearance while engine is cold.

NOTE:

- Perform adjustment by selecting the correct head thickness of the valve lifter (adjusting shims are not used).

CAMSHAFT VALVE CLEARANCE

< PERIODIC MAINTENANCE >

- The specified valve lifter thickness dimension is measured at room temperature.
- Use specifications for hot engine for hot engine condition to confirm valve clearances.

1. Remove the camshaft.
2. Remove the valve lifter that was measured as being outside the standard specifications.
3. Measure the center thickness of the removed lifter with suitable tool (A) as shown.

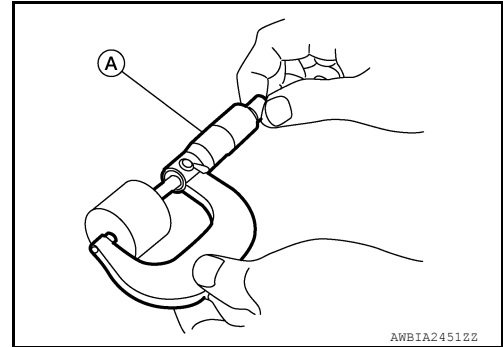

4. Use the equation below to calculate the replacement valve lifter thickness.

Valve lifter thickness calculation: $(C_1 - C_2) + t_1 = t$

C_1 = measured valve clearance

C_2 = standard valve clearance

t_1 = thickness of the removed lifter

t = thickness of the replacement lifter

- a. The thickness of the new valve lifter can be identified by the stamp mark (A) on the reverse side (inside the lifter).

NOTE:

Available thicknesses of the valve lifters (B) are: 3.00 - 3.50 mm (0.1181 - 0.1378 in), in 0.02 mm (0.0008 in) increments. Refer to [EM-137. "Camshaft"](#)

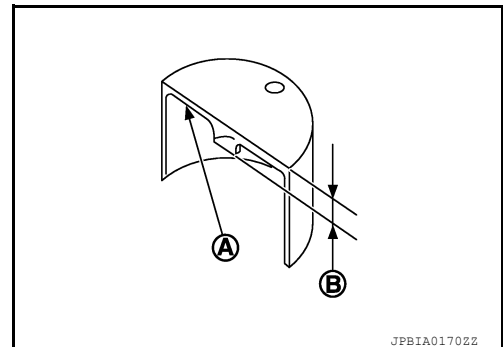

5. Install the selected replacement valve lifter.
6. Install the camshaft.
7. Rotate the crankshaft a few turns by hand.
8. Confirm that the valve clearances are within specification.
9. After the engine has been run to full operating temperature, confirm that the valve clearances are within specification.

Standard Valve Clearance	Cold ¹ (reference data)	Hot ² (reference data)
Intake	0.26 - 0.34 mm (0.010 - 0.013 in)	0.304 - 0.416 mm (0.012 - 0.016 in)
Exhaust	0.29 - 0.37 mm (0.011 - 0.015 in)	0.308 - 0.432 mm (0.012 - 0.017 in)

¹ : Approximately 20°C (68°F)

² : Approximately 80°C (176°F)

COMPRESSION PRESSURE

< PERIODIC MAINTENANCE >

COMPRESSION PRESSURE

On-Vehicle Service

INFOID:000000011220635

CHECKING COMPRESSION PRESSURE

1. Run the engine until it reaches normal operating temperature.
2. Turn the ignition switch to OFF.
3. Release fuel pressure and leave the fuel pump electrically disconnected.
Refer to [EC-166. "Work Procedure"](#).
4. Remove all six spark plugs.
Refer to [EM-18. "Removal and Installation"](#).
5. Attach a compression tester to No. 1 cylinder.

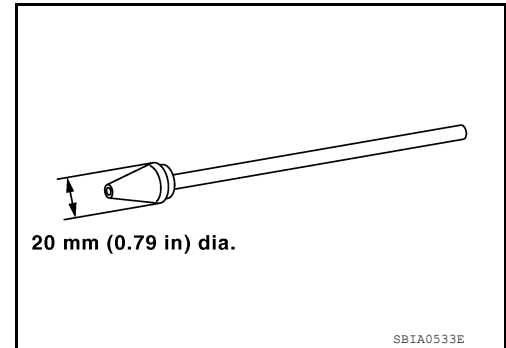

6. Depress accelerator pedal fully to keep the electric throttle control actuator butterfly-valve wide open to maximize air intake flow.
7. Crank the engine and record the highest gauge indication.
CAUTION:
Always use a fully charged battery to obtain specified engine speed.
8. Repeat the test for each cylinder (steps 5 - 7).

Unit: kPa (kg/cm², psi) /rpm

Standard	Minimum	Differential limit between cylinders
1,275 (13.0, 185) / 300	981 (10.0, 142) / 300	98 (1.0, 14) / 300

- If the engine speed is out of the specified range, check the battery and recharge as necessary. Check the engine speed again with the battery properly charged.
 - If some cylinders have low compression pressure, pour a small amount of engine oil into the spark plug hole of the cylinder to recheck it for compression.
 - If the added engine oil improves the compression, piston rings may be worn out or damaged. Check the piston rings and replace if necessary.
 - If the compression pressure remains at low level despite the addition of engine oil, the valves may be malfunctioning. Check the valves for damage. Replace the valve or valve seat accordingly.
 - If two adjacent cylinders have respectively low compression pressure and their compression remains low, even after the addition of engine oil, cylinder head gaskets may be leaking, or a valve in adjacent cylinders may be damaged. Inspect and repair as required.
 - If the compression pressure is below the minimum value, check the valve clearances and parts associated with the combustion chamber (valve, valve seat, piston, piston ring, cylinder bore, cylinder head, cylinder head gasket). After the checking, measure the compression pressure again.
9. Installation of the remaining components is in the reverse order of removal.

ENGINE ROOM COVER

< REMOVAL AND INSTALLATION >

REMOVAL AND INSTALLATION

ENGINE ROOM COVER

Exploded View

INFOID:000000011220636

A

EM

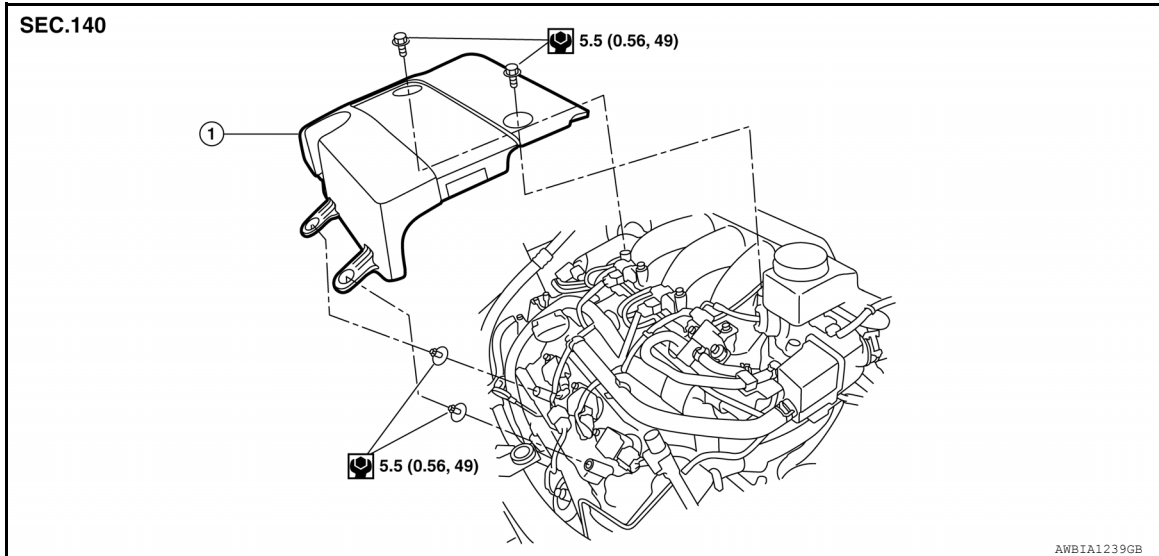

C

D

E

F

G

H

1. Engine cover

Removal and Installation

INFOID:000000011220637

CAUTION:

Do not damage or scratch engine room cover when installing or removing.

REMOVAL

1. Remove front air duct. Refer to [EM-26, "Removal and Installation"](#).
2. Remove engine cover bolts.
3. Remove engine cover.

INSTALLATION

Installation is in the reverse order of removal.

J

K

L

M

N

O

P

AIR CLEANER AND AIR DUCT

< REMOVAL AND INSTALLATION >

AIR CLEANER AND AIR DUCT

Exploded View

INFOID:000000011220638

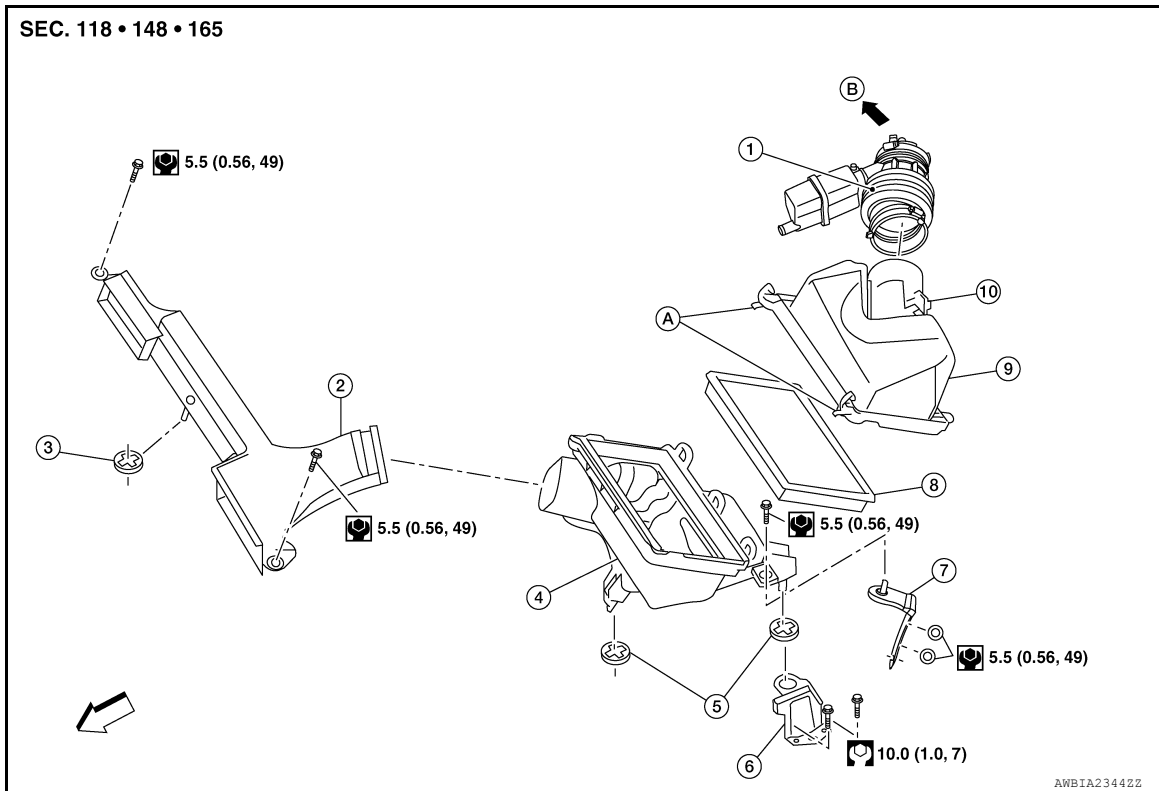

- | | | |
|---|--|--|
| 1. Air duct hose and resonator assembly | 2. Front air duct | 3. Grommet |
| 4. Air cleaner case (lower) | 5. Grommets | 6. Air cleaner case mounting bracket |
| 7. Bracket | 8. Air cleaner filter | 9. Air cleaner case (upper) |
| 10. Mass air flow sensor | A. To electric throttle control actuator | B. To electric throttle control actuator |

⇐ Front

Removal and Installation

INFOID:000000011220639

REMOVAL

1. Remove front air duct.
2. Remove brake fluid level sensor harness connector from brake fluid level sensor.
3. Remove sub tank bracket from cowl top extension.
4. Disconnect the tube clamp at the electric throttle control actuator and at the air duct hose and resonator assembly.
5. Disconnect the blow-by hose. Refer to [EM-45. "Exploded View"](#)
6. Remove air duct hose and resonator assembly.
7. Disconnect mass air flow sensor.
8. Remove mass air flow sensor from air cleaner case (upper), (if necessary).
CAUTION:
Handle mass air flow sensor with care.
 - Do not shock it.
 - Do not disassemble it.
 - Do not touch its sensor.
9. Disconnect the transaxle air breather hose. Refer to [TM-200. "Removal and Installation"](#)

AIR CLEANER AND AIR DUCT

< REMOVAL AND INSTALLATION >

10. Remove bolts and pull air cleaner case (lower) upward to remove from the grommets.

11. Remove air cleaner assembly.

A

INSPECTION AFTER REMOVAL

Inspect air cleaner case (upper), air cleaner case (lower), front air duct, air duct and resonator assembly for cracks or tears. Replace as necessary.

EM

INSTALLATION

Installation is in the reverse order of removal.

C

D

E

F

G

H

I

J

K

L

M

N

O

P

INTAKE MANIFOLD COLLECTOR

< REMOVAL AND INSTALLATION >

INTAKE MANIFOLD COLLECTOR

Exploded View

INFOID:000000011220640

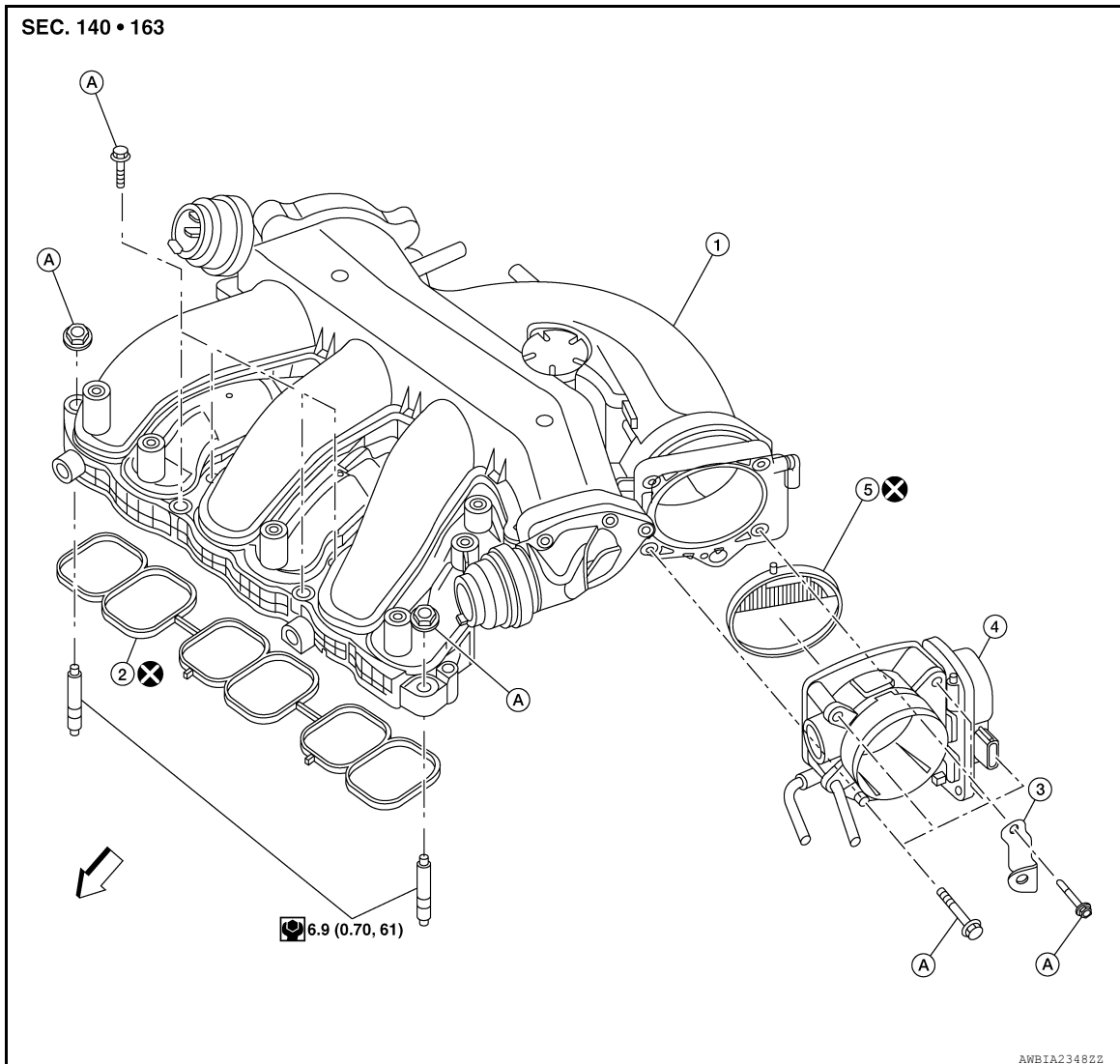

- | | | |
|---------------------------------------|--|--------------------------|
| 1. Intake manifold collector | 2. Intake manifold collector gasket | 3. Bracket clip |
| 4. Electric throttle control actuator | 5. Electric throttle control actuator gasket | A. Refer to INSTALLATION |

↶ Front

Removal and Installation

INFOID:000000011220641

WARNING:

Do not drain the engine coolant when the engine is hot to avoid the danger of being scalded.

CAUTION:

Do not remove the power valves.

NOTE:

When removing components such as hoses, tubes/lines, etc., cap or plug openings to prevent fluid from spilling.

REMOVAL

CAUTION:

Cover engine openings to avoid the entry of any foreign material.

INTAKE MANIFOLD COLLECTOR

< REMOVAL AND INSTALLATION >

1. Remove the cowl top cover and the cowl top extension. Refer to [EXT-34, "Exploded View"](#).
2. Remove the engine room cover. Refer to [EM-25, "Removal and Installation"](#).
3. Remove the air cleaner case (upper), air cleaner case (lower), and air duct and resonator assembly. Refer to [EM-26, "Removal and Installation"](#).
4. Disconnect the power brake booster vacuum hose.
5. Disconnect the engine mount control valve solenoid harness connector.
6. Disconnect VIAS control solenoid valve harness connector.
7. Disconnect the PCV hose.
8. Disconnect the electric throttle control actuator electrical harness connector.
9. Disconnect the EVAP canister purge volume control solenoid valve hose.
10. Remove the electric throttle control actuator bolts and remove the electric throttle control actuator and position aside. Loosening is done in reverse order of torquing.

CAUTION:

- Handle carefully to avoid any shock to the electric throttle control actuator.
- Do not disassemble.

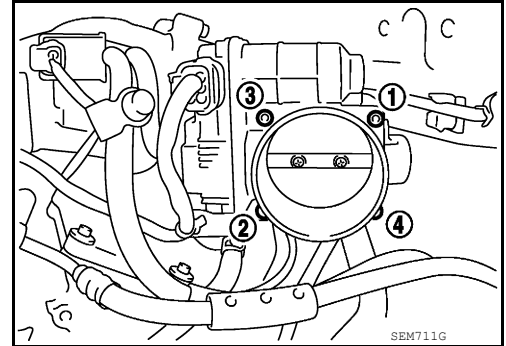

11. Remove the VIAS control solenoid valve as necessary.
12. Remove the EVAP canister purge volume control solenoid valve.
13. Loosen the intake manifold collector bolts and remove the intake manifold collector and gasket. Loosening is done in reverse order of torquing.

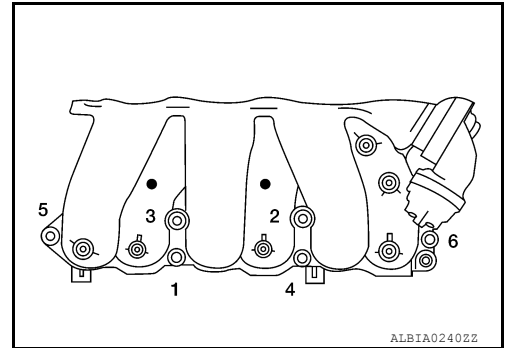

INSTALLATION

Installation is in the reverse order of removal.

- Tighten intake manifold collector bolts in the order as shown.

Intake manifold collector bolts : 11.0 N·m (1.1 kg-m, 8 ft-lb)

CAUTION:

Do not reuse intake manifold collector gasket.

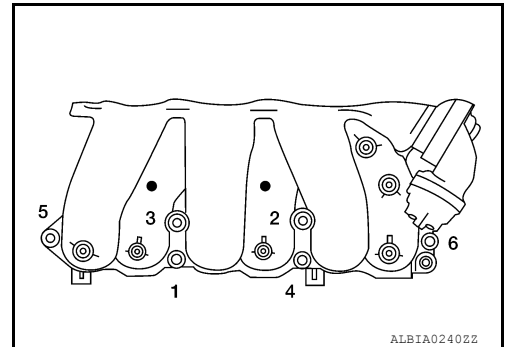

- Tighten electric throttle control actuator bolts in the order shown.

Electric throttle control actuator bolts : 8.4 N·m (0.86 kg-m, 74 in-lb)

CAUTION:

A
EM
C
D
E
F
G
H
I
J
K
L
M
N
O
P

INTAKE MANIFOLD COLLECTOR

< REMOVAL AND INSTALLATION >

Do not reuse electric throttle control actuator gasket.

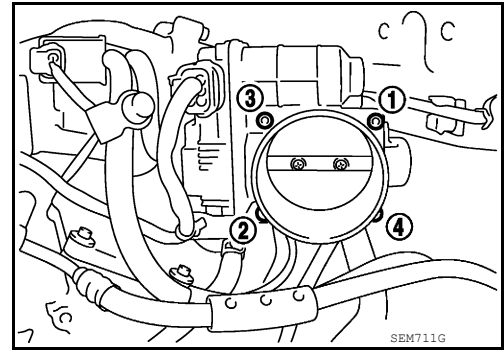

NOTE:

After installation, recalibrate the electric throttle control actuator as follows:

1. Perform the "Throttle Valve Closed Position Learning" when harness connector of the electric throttle control actuator is disconnected. Refer to [EC-157, "Work Procedure"](#).
2. Perform the "Idle Air Volume Learning" when the electric throttle control actuator is replaced. Refer to [EC-158, "Work Procedure"](#).
3. Perform the "Accelerator Pedal Released Position Learning" when the electric throttle control actuator is replaced. Refer to [EC-156, "Work Procedure"](#).

INTAKE MANIFOLD

< REMOVAL AND INSTALLATION >

INTAKE MANIFOLD

Exploded View

INFOID:000000011220642

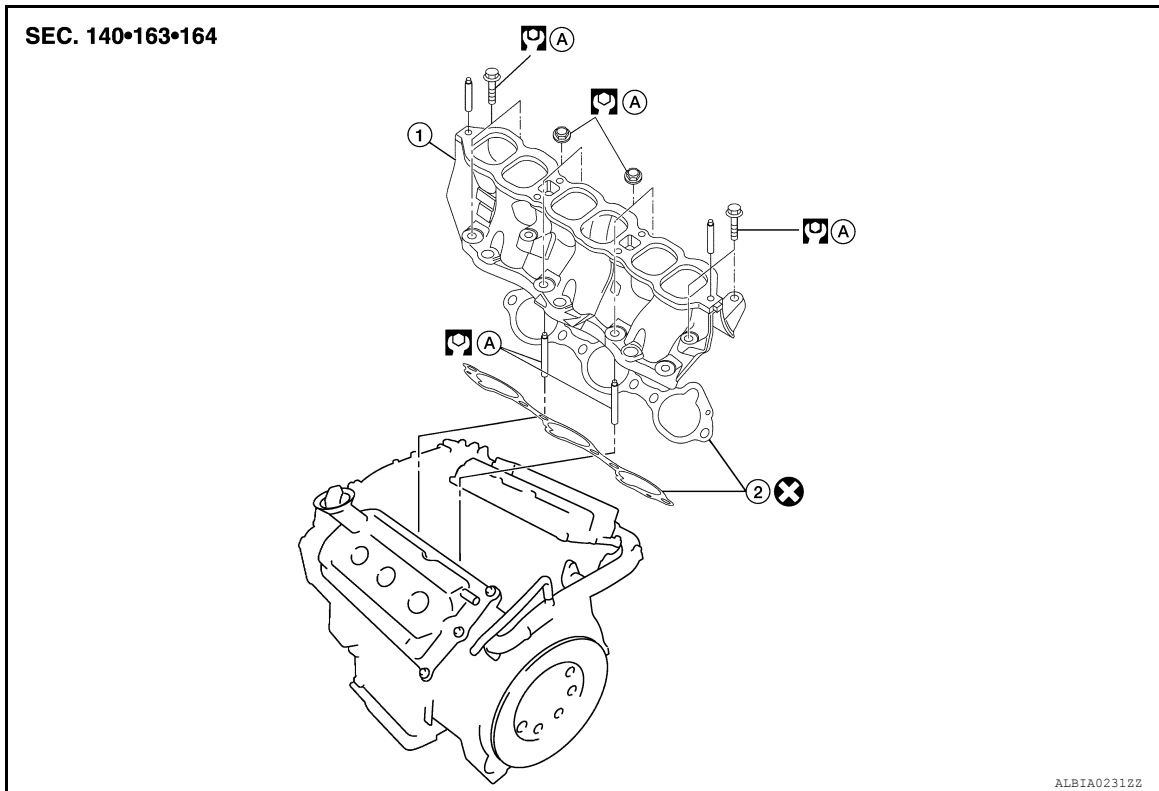

1. Intake manifold 2. Intake manifold gasket A. Refer to INSTALLATION

Removal and Installation

INFOID:000000011722662

REMOVAL

WARNING:

To avoid the danger of being scalded, do not drain the coolant when the engine is hot.

NOTE:

When removing components such as hoses, tubes/lines, etc., cap or plug openings to prevent fluid from spilling.

1. Remove fuel injectors and fuel tube. Refer to [EM-49, "Removal and Installation"](#).
2. Remove the intake manifold and the intake manifold gaskets. Loosen nuts and bolts in reverse order as shown.

CAUTION:

Cover the engine openings to avoid the entry of foreign materials.

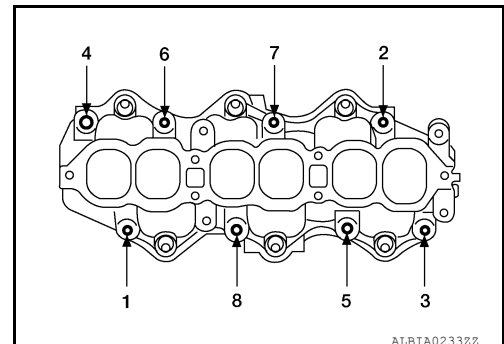

INSPECTION AFTER REMOVAL
Surface Distortion

INTAKE MANIFOLD

< REMOVAL AND INSTALLATION >

- Using straightedge and feeler gauge, inspect the surface distortion of the intake manifold.

Standard : 0.1 mm (0.004 in)

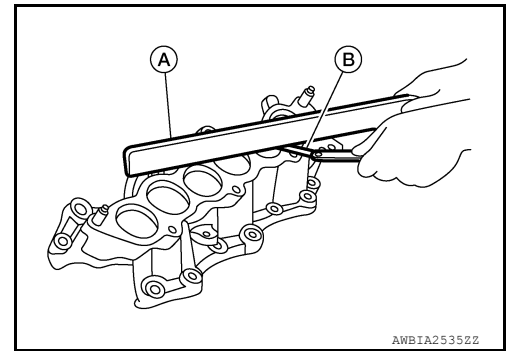

INSTALLATION

Installation is in the reverse order of removal. Follow the procedure below for specific tightening sequences and procedures.

CAUTION:

Do not reuse intake manifold gaskets.

- Install intake manifold nuts and bolts in two steps in the numerical order as shown.

Step 1 : 7.4 N·m (0.75 kg-m, 65 in-lb)

Step 2 : 25.5 N·m (2.6 kg-m, 19 ft-lb)

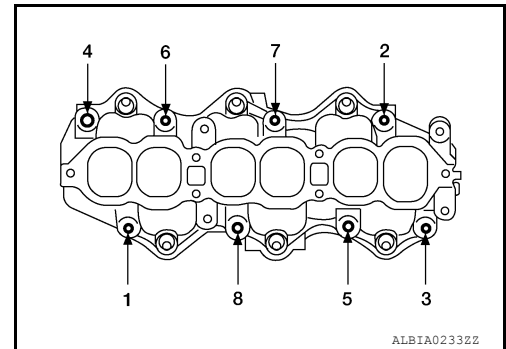

INSPECTION AFTER INSTALLATION

Make sure there are no fuel leaks at the connections as follows:

1. Apply fuel pressure to fuel lines by turning ignition switch ON (with engine stopped). Then check for fuel leaks at connections.
2. Start the engine and rev it up and check for fuel leaks at connections.

WARNING:

Do not touch engine immediately after stopping as engine is extremely hot.

NOTE:

Use mirrors for checking on connections out of the direct line of sight.

EXHAUST MANIFOLD AND THREE WAY CATALYST

< REMOVAL AND INSTALLATION >

EXHAUST MANIFOLD AND THREE WAY CATALYST

Exploded View

INFOID:000000011220644

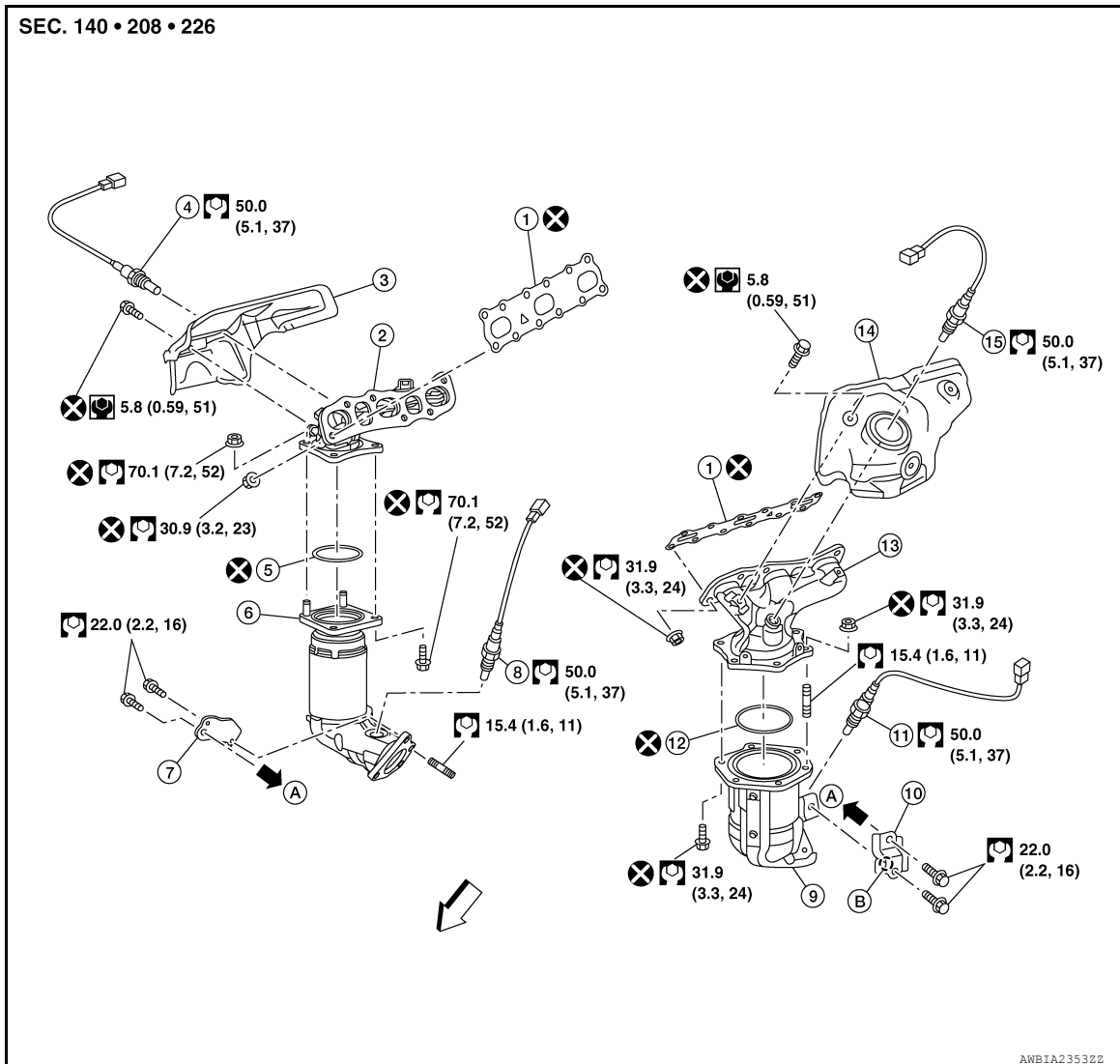

- | | | |
|---|-------------------------------------|--------------------------------------|
| 1. Gasket | 2. Exhaust manifold (bank 1) | 3. Exhaust manifold cover (bank 1) |
| 4. Air fuel ratio sensor 1 (bank 1) | 5. Ring gasket | 6. Three way catalyst (bank 1) |
| 7. Three way catalyst support (bank 1) | 8. Heated oxygen sensor 2 (bank 1) | 9. Three way catalyst (bank 2) |
| 10. Three way catalyst support (bank 2) | 11. Heated oxygen sensor 2 (bank 2) | 12. Ring gasket |
| 13. Exhaust manifold (bank 2) | 14. Exhaust manifold cover (bank 2) | 15. Air fuel ratio sensor 1 (bank 2) |
| A. To oil pan (upper) | B. Upper mark | ⇐ Engine front |

Removal and Installation (bank 2)

INFOID:000000011220645

REMOVAL

WARNING:

- Perform the work when the exhaust system has completely cooled down.
- When removing the front and rear engine mounting through bolts and nuts, lift the engine up slightly for safety.

NOTE:

When removing components such as hoses, tubes/lines, etc., cap or plug openings to prevent fluid from spilling.

EXHAUST MANIFOLD AND THREE WAY CATALYST

< REMOVAL AND INSTALLATION >

1. Remove the air cleaner case (upper), air cleaner case (lower), and air duct hose and resonator assembly. Refer to [EM-26, "Removal and Installation"](#).
2. Remove the battery and battery tray assembly. Refer to [PG-88, "Removal and Installation"](#).
3. Remove the front wheels and tires using power tool. Refer to [WT-68, "Removal and Installation"](#).
4. Remove the engine under cover. Refer to [EXT-40, "FRONT UNDER COVER : Removal and Installation"](#).
5. Remove the fender protector side covers (LH and RH). Refer to [EXT-36, "FENDER PROTECTOR : Exploded View"](#).
6. Remove the radiator assembly. Refer to [CO-13, "Removal and Installation"](#).
7. Remove the engine cooling fan shroud and motor assembly. Refer to [CO-15, "Removal and Installation"](#).
8. Remove the front exhaust tube. Refer to [EX-5, "Exploded View"](#).
9. Support the engine with a suitable tool.
10. Remove the engine mount bracket (front). Refer to [EM-104, "FWD : Exploded View"](#) (FWD) or [EM-108, "AWD : Exploded View"](#) (AWD).
11. Remove the three way catalyst support (bank 2).
12. Remove heated oxygen sensor 2 (bank 2), air fuel ratio (A/F) sensor 1 (bank 2).
 - a. Remove harness connector of each sensor, and disconnect the harness from the bracket and middle clamp.
 - b. Remove both heated oxygen sensor and air fuel ratio (A/F) sensor using Tool.

Tool numbers : KV10114400 (J-38365)
: KV991J0050 (J-44626)

CAUTION:

- Be careful not to damage heated oxygen sensors or air fuel ratio (A/F) sensors.
- Discard any heated oxygen sensor which has been dropped from a height of more than 0.5 m (19.7 in) onto a hard surface such as a concrete floor; replace with a new sensor.

13. Remove exhaust manifold and three way catalyst heat shields with power tool.
14. Remove the three way catalyst (bank 2) by loosening the bolts first and then removing the nuts and through bolts.
15. Loosen and remove the exhaust manifold nuts in the reverse order as shown.

⇐ : Engine front

NOTE:

Number 7 and 8 are not applicable to removal.

16. Remove the exhaust manifold (LH) and gasket.

⇐ : Engine front

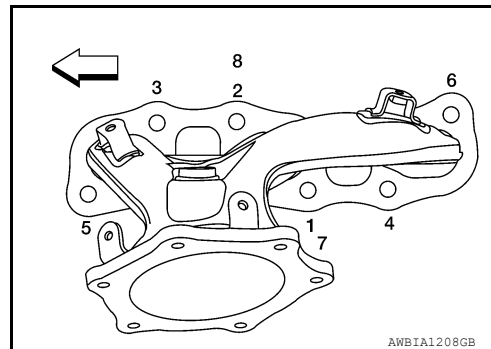

INSPECTION AFTER REMOVAL

Surface Distortion

- Use suitable tools (A/B) to check the flatness of the exhaust manifold mating surfaces.

Limit : 0.3 mm (0.012 in)

- Replace the exhaust manifold if the measurement exceeds specifications.

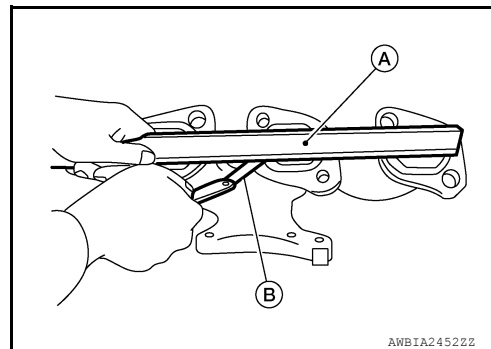

INSTALLATION

EXHAUST MANIFOLD AND THREE WAY CATALYST

< REMOVAL AND INSTALLATION >

Installation is in the reverse order of removal.

1. Install the studs in the exhaust manifold (if removed), and tighten to specification.

Exhaust manifold studs : 15.4 N·m (1.6 kg-m, 11 ft-lb)

2. Install the exhaust manifold gasket in the direction shown.

CAUTION:

Do not reuse exhaust manifold gasket.

- (A) : Bank 1
- (B) : Triangle press
- (C) : Bank 2
- ⇐ : Engine front

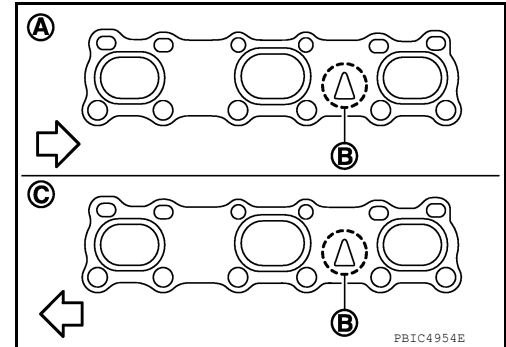

3. Install the exhaust manifold (bank 2) nuts and tighten to specification in the order shown.

- ⇐ : Engine front

NOTE:

Number 7 and 8 are tightened a second time.

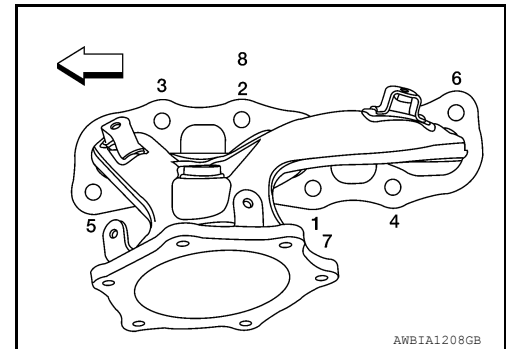

CAUTION:

- Before installing a heated oxygen sensor or air fuel ratio (A/F) sensor, clean the exhaust manifold threads using the oxygen sensor thread cleaner tool and apply anti-seize lubricant.

Oxygen sensor thread cleaner : (J-43897-18)

- Do not over-tighten the air fuel ratio (A/F) sensor or heated oxygen sensors. Doing so may cause damage.

Tool numbers : KV10114400 (J-38365)

: KV991J0050 (J-44626)

NOTE:

After installation, it is necessary to re-calibrate the electric throttle control actuator as follows:

- Perform the "Throttle Valve Closed Position Learning" when harness connector of the ECM is disconnected. Refer to [EC-157, "Work Procedure"](#).
- Perform the "Accelerator Pedal Released Position Learning" when harness connector of the ECM is disconnected. Refer to [EC-156, "Work Procedure"](#).

Removal and Installation (bank 1)

INFOID:000000011220646

REMOVAL

WARNING:

- Perform the work when the exhaust system has completely cooled down.
- When removing the front and rear engine mounting through bolts and nuts, lift the engine up slightly for safety.

NOTE:

When removing components such as hoses, tubes/lines, etc., cap or plug openings to prevent fluid from spilling.

EXHAUST MANIFOLD AND THREE WAY CATALYST

< REMOVAL AND INSTALLATION >

1. Remove the cowl top and the lower cowl top extension. Refer to [EXT-34, "Exploded View"](#).
2. Remove the front wheel and tire (RH) (AWD models only) using a power tool. Refer to [WT-68, "Removal and Installation"](#).
3. Remove the engine under cover. Refer to [EXT-40, "FRONT UNDER COVER : Removal and Installation"](#).
4. Remove the fender protector side cover (RH) (AWD models only). Refer to [EXT-36, "FENDER PROTECTOR : Exploded View"](#).
5. Remove transmission air breather hose. Refer to [TM-200, "Exploded View"](#).
6. Remove the front exhaust tube, hanger and heat insulator. Refer to [EX-5, "Exploded View"](#).
7. Remove the propeller shaft and propeller shaft center bearing (AWD models only). Refer to [RAX-11, "Removal and Installation"](#).
8. Remove the RH front axle shaft (AWD models only). Refer to [FAX-21, "Removal and Installation \(RH\)"](#).
9. Remove the three way catalyst support (bank 1).
10. Remove heated oxygen sensor 2 (bank 1), air fuel ratio (A/F) sensor 1 (bank 1).
 - a. Remove harness connector of each sensor, and disconnect the harness from the bracket and middle clamp.
 - b. Remove both heated oxygen sensors and air fuel ratio (A/F) sensors using Tool.

Tool numbers : KV10114400 (J-38365)
: KV991J0050 (J-44626)

CAUTION:

- Be careful not to damage heated oxygen sensors or air fuel ratio (A/F) sensors.
- Discard any heated oxygen sensor which has been dropped from a height of more than 0.5 m (19.7 in) onto a hard surface such as a concrete floor; replace with a new sensor.

11. Remove exhaust manifold and three way catalyst heat shields with power tool.
12. Remove the three way catalyst (bank 1) by loosening the bolts first and then removing the nuts and through bolts.
13. Loosen the exhaust manifold nuts in the reverse order as shown.

← : Engine front

NOTE:

Number 7 and 8 are not applicable to removal.

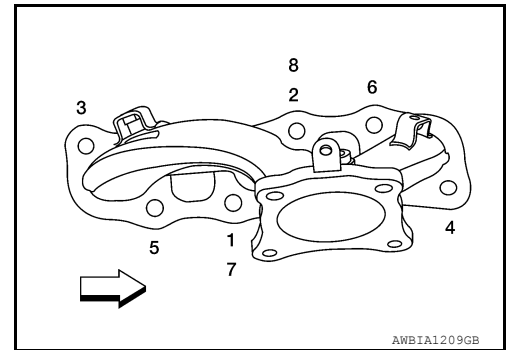

14. Remove the exhaust manifold (bank 1).

INSPECTION AFTER REMOVAL

Surface Distortion

- Use suitable tools (A/B) to check the flatness of the exhaust manifold mating surfaces.

Limit : 0.3 mm (0.012 in)

- Replace the exhaust manifold if the measurement exceeds specifications.

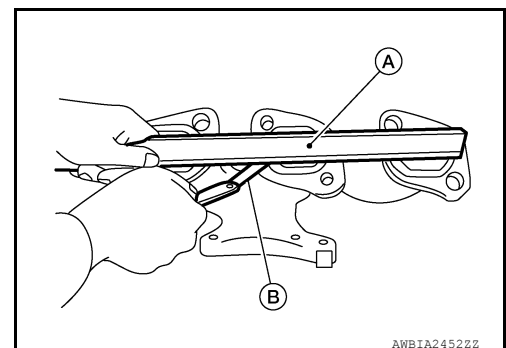

INSTALLATION

Installation is in the reverse order of removal.

EXHAUST MANIFOLD AND THREE WAY CATALYST

< REMOVAL AND INSTALLATION >

1. Install the studs in the exhaust manifold (if removed), and tighten to specification.

Exhaust manifold studs : 15.4 N·m (1.6 kg-m, 11 ft-lb)

2. Install the exhaust manifold gasket in the direction shown.

CAUTION:

Do not reuse exhaust manifold gasket.

- (A) : Bank 1
- (B) : Triangle press
- (C) : Bank 2
- ⇐ : Engine front

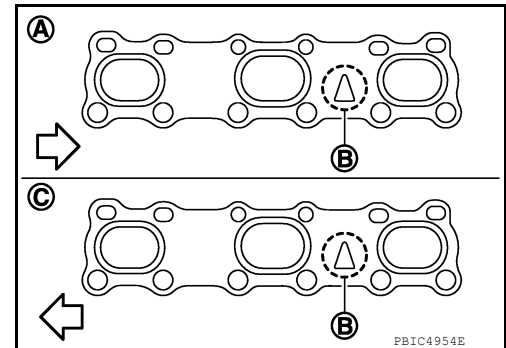

3. Install the exhaust manifold (bank 1) nuts and tighten to specification in the order shown.

- ⇐ : Engine front

NOTE:

Number 7 and 8 are tightened a second time.

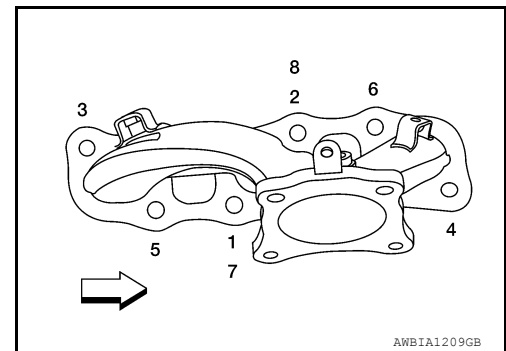

CAUTION:

- Before installing a heated oxygen sensor or air fuel ratio (A/F) sensor, clean the exhaust manifold threads using the oxygen sensor thread cleaner tool and apply anti-seize lubricant.

Oxygen sensor thread cleaner : (J-43897-18)

- Do not over-tighten the air fuel ratio (A/F) sensor or heated oxygen sensors. Doing so may cause damage.

Tool numbers : KV10114400 (J-38365)

: KV991J0050 (J-44626)

OIL PAN AND OIL STRAINER

< REMOVAL AND INSTALLATION >

OIL PAN AND OIL STRAINER

Exploded View

INFOID:000000011220647

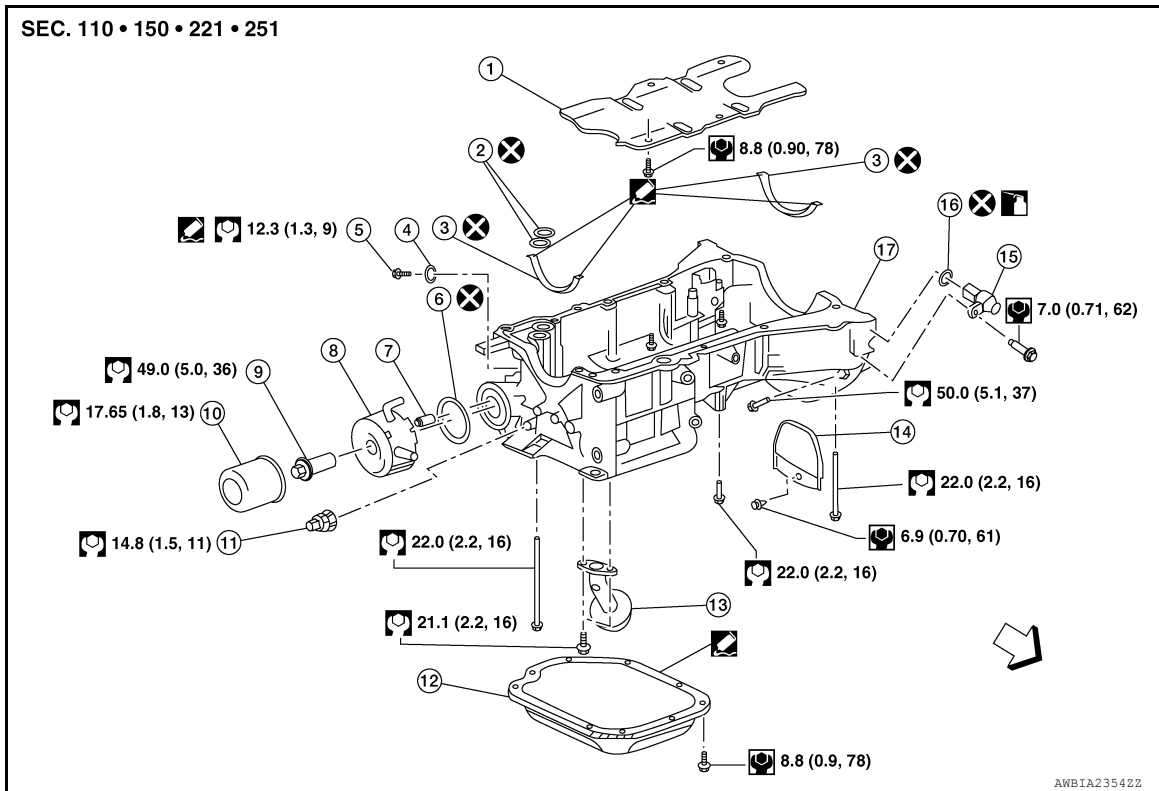

- | | | |
|----------------------|-------------------------|--------------------------------------|
| 1. Oil pan baffle | 2. O-ring | 3. Upper oil pan gasket |
| 4. Blind plug O-ring | 5. Blind plug | 6. Oil cooler O-ring |
| 7. Relief valve | 8. Oil cooler | 9. Oil cooler connector |
| 10. Oil filter | 11. Oil pressure sensor | 12. Lower oil pan |
| 13. Oil strainer | 14. Rear cover plate | 15. Crankshaft position sensor (POS) |
| 16. O-ring | 17. Upper oil pan | ← Front |

Removal and Installation (Lower Oil Pan)

INFOID:000000011545081

REMOVAL

WARNING:

• You should not remove the oil pan until the exhaust system and cooling system have completely cooled off.

1. Drain the engine oil. Refer to [LU-9, "Changing Engine Oil"](#).
2. Loosen the lower oil pan bolts in reverse order as shown.

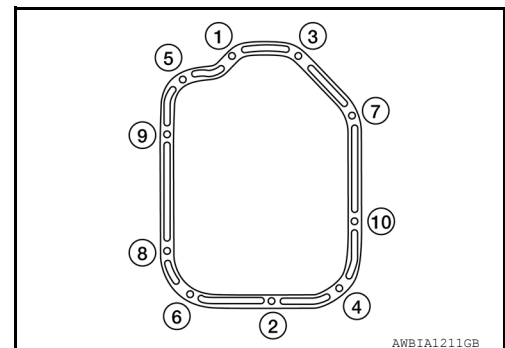

3. Remove the lower oil pan.

OIL PAN AND OIL STRAINER

< REMOVAL AND INSTALLATION >

- After removing the bolts, separate the mating surface and remove the old liquid gasket using Tool.

Tool number : KV10111100 (J-37228)

CAUTION:

Do not damage the mating surfaces.

- In areas where the Tool is difficult to use, use a plastic hammer to lightly tap (1) the Tool where the liquid gasket is applied. Use a plastic hammer to slide (2) the Tool by tapping on the side.

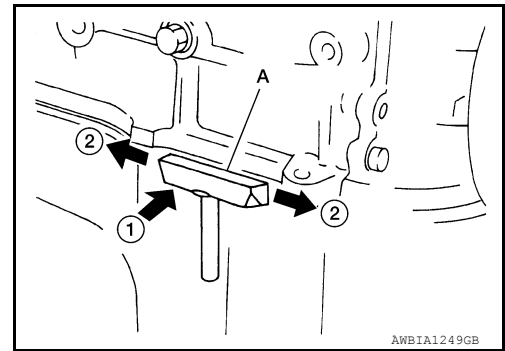

4. Remove the old sealant from the bolt holes and threads.

INSPECTION AFTER REMOVAL

Clean debris from the oil strainer.

INSTALLATION

1. Apply a continuous bead of sealant to the lower oil pan.
 - Use Genuine Silicone RTV Sealant, or equivalent. Refer to [GL-22, "Recommended Chemical Products and Sealants"](#).
 - Be sure the sealant is 4.5 - 5.5 mm (0.177 - 0.217 in) wide.

CAUTION:

- Installation should be done within 5 minutes after applying liquid gasket.
- Do not fill the engine with engine oil for at least 30 minutes after the components are installed to allow the sealant to cure.

← Front

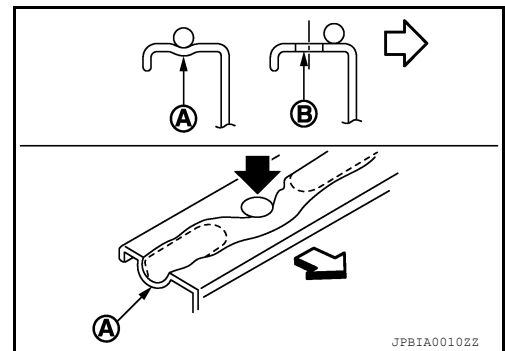

2. Install the lower oil pan. Tighten the lower oil pan bolts in order as shown.

CAUTION:

- Installation should be done within 5 minutes after applying liquid gasket.
- Do not fill the engine with engine oil for at least 30 minutes after the components are installed to allow the sealant to cure.

3. Refill the engine with oil. Refer to [LU-9, "Changing Engine Oil"](#).

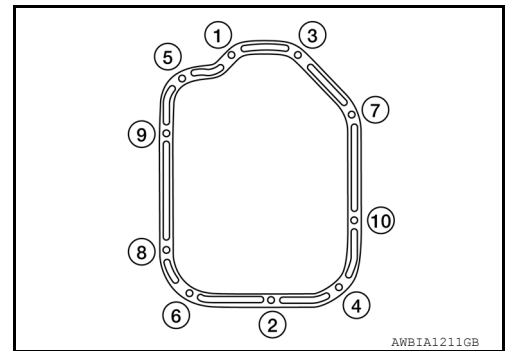

INSPECTION AFTER INSTALLATION

1. Inspect the engine oil level. Refer to [LU-8, "Inspection"](#).
2. Start the engine and check for leaks. Refer to [LU-8, "Inspection"](#). Repair as necessary.

Removal and Installation (Upper Oil Pan)

INFOID:000000011545082

REMOVAL

WARNING:

- Do not remove the oil pan until the exhaust system and cooling system have completely cooled off.
- When removing the front and rear engine through bolts and nuts, lift the engine up slightly for safety.

CAUTION:

When removing the upper oil pan from the engine, first remove the crankshaft position sensor (POS). Be careful not to damage sensor edges or signal plate teeth.

NOTE:

When removing components such as hoses, tubes/lines, etc., cap or plug openings to prevent fluid from spilling.

OIL PAN AND OIL STRAINER

< REMOVAL AND INSTALLATION >

1. Remove the engine from the vehicle. Refer to [EM-104. "FWD : Removal and Installation"](#) (FWD) or [EM-109. "AWD : Removal and Installation"](#) (AWD).
2. Install the engine on engine stand (A). Any commercially available engine stand (A) can be used.

CAUTION:

- Use an engine stand (A) that has a load capacity [approximately 240kg (529 lb) or more] large enough for supporting the engine weight.
- Before removing the hanging chains, make sure the engine stand (A) is stable and there is no risk of overturning.

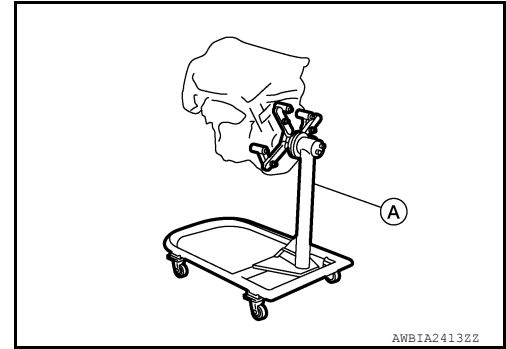

3. Remove the oil dipstick.
4. Remove the drive belt. Refer to [EM-14. "Removal and Installation"](#).
5. Disconnect the A/C compressor harness connector.
6. Remove the A/C compressor bolts and remove the A/C compressor. Refer to [HA-29. "COMPRESSOR : Removal and Installation"](#).
7. Remove water pipe bolts.
8. Disconnect the water hoses from the engine oil cooler.
9. Remove the oil filter and engine oil cooler from the upper oil pan. Refer to [EM-39. "Removal and Installation \(Upper Oil Pan\)"](#).
10. Remove the oil pressure switch, and the crankshaft position sensor (POS) from the upper oil pan.
11. Remove the lower oil pan. Refer to [EM-38. "Removal and Installation \(Lower Oil Pan\)"](#).
12. Remove the oil strainer.
13. Remove the upper oil pan.
 - a. Loosen the bolts in the reverse order shown.

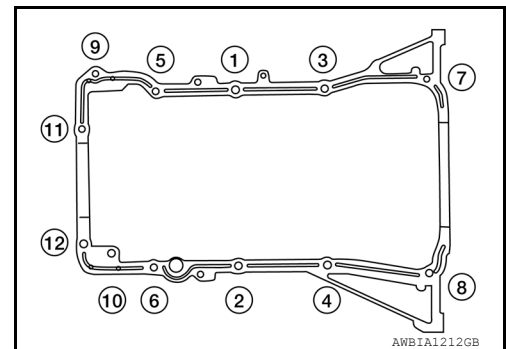

- b. Insert a suitable tool (A) into the notch (B) of the upper oil pan (1) as shown.
- c. Pry off the upper oil pan (1) by moving the suitable tool up and down (2) as shown.

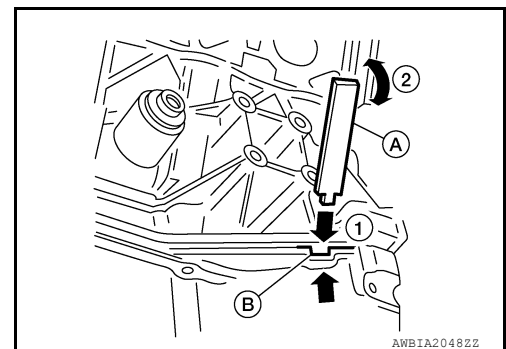

14. Remove rear engine mount buffer bracket.

OIL PAN AND OIL STRAINER

< REMOVAL AND INSTALLATION >

15. Remove the O-rings (2) from the bottom of the cylinder block (1) and oil pump housing. Use new O-rings for installation.

↶ : Engine front

CAUTION:
Do not reuse O-rings.

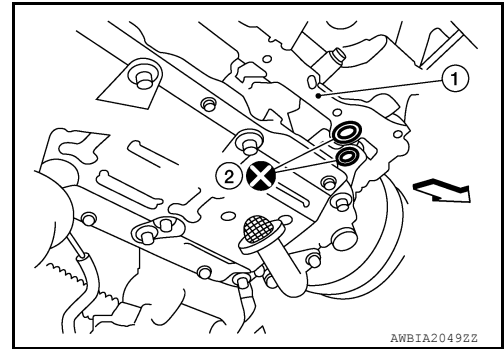

16. Remove front cover gasket (A) and rear oil seal retainer gasket (B).

↶ : Engine front

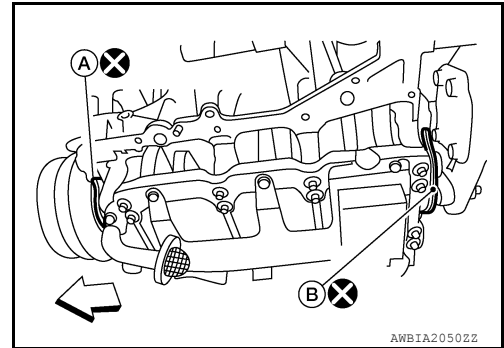

17. If reinstalling the original oil pan, remove the old sealant from the mating surfaces using a suitable tool (A).
- Also remove the old sealant from mating surface of the cylinder block.
 - Remove the old sealant from the bolt holes and threads.
- CAUTION:**
Do not scratch or damage the mating surfaces when cleaning off the old sealant.

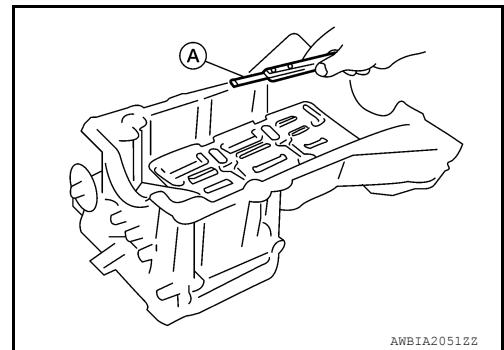

INSPECTION AFTER REMOVAL

Clean debris from oil strainer.

INSTALLATION

1. Install oil strainer and tighten bolt to specified torque.

Oil strainer bolts : 21.1 N·m (2.2 kg-m, 16 ft-lb)

2. Apply Genuine Silicone RTV Sealant or equivalent (A) to the front cover gasket and the rear oil seal retainer gasket as shown. Refer to [GI-22, "Recommended Chemical Products and Sealants"](#).

CAUTION:

- Installation should be done within 5 minutes after applying liquid gasket.
- Do not fill the engine with oil for at least 30 minutes after the components are installed to allow the sealant to cure.

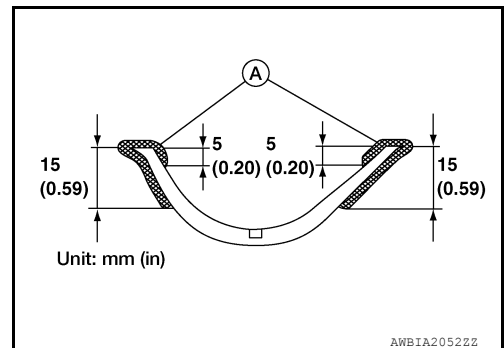

OIL PAN AND OIL STRAINER

< REMOVAL AND INSTALLATION >

3. Install the front cover gasket (A) and rear oil seal retainer gasket (B) as shown.

CAUTION:

Do not reuse front cover gasket or rear oil seal retainer gasket.

← : Engine front

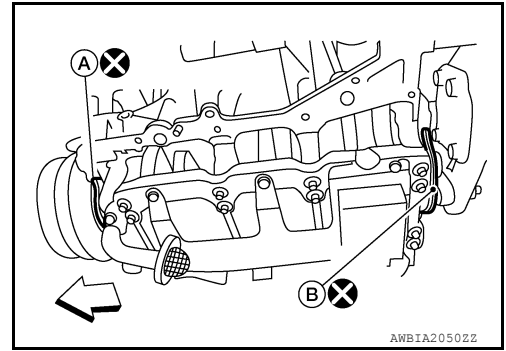

4. Apply a bead of sealant to the cylinder block mating surface of the upper oil pan as shown.

CAUTION:

- Installation should be done within 5 minutes after applying liquid gasket.
- Do not fill the engine with oil for at least 30 minutes after the components are installed to allow the sealant to cure.

NOTE:

- Apply liquid gasket to the outside of bolt holes 5, 6, 10, 11 and 12.
- Apply liquid gasket to the inside of the other bolt holes.

- a. Be sure the sealant is applied 5.0 mm (0.197 in) as shown (A). Increase the bead to 4.5 - 5.5 mm (0.177 - 0.217 in) at the four places indicated (B).
- b. Use Genuine Silicone RTV Sealant, or equivalent. Refer to [GL-22. "Recommended Chemical Products and Sealants"](#).

← : Engine front

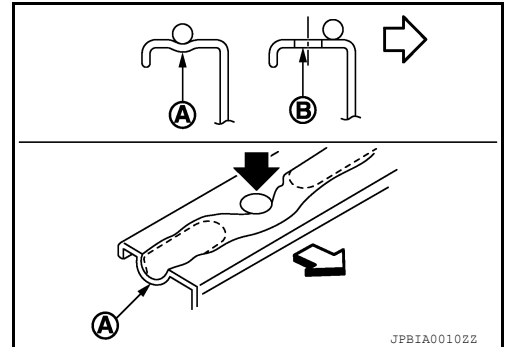
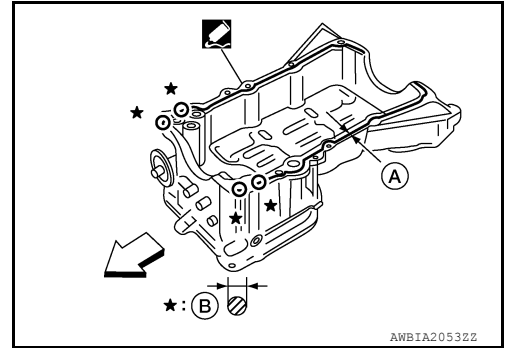

5. Install new O-rings (2) on the cylinder block (1) and oil pump body.

CAUTION:

Do not reuse O-rings.

← : Engine front

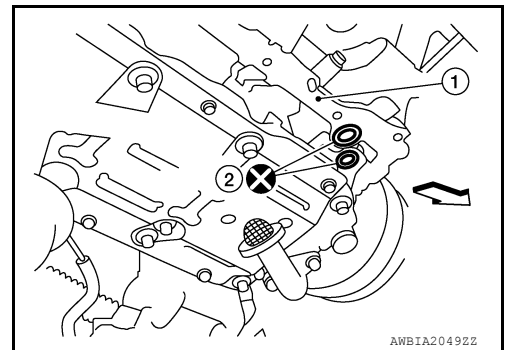

6. Install the upper oil pan.
- Tighten bolts (1) and (2) to specification within 5 minutes of applying the liquid gasket.
 - Tighten the remaining upper oil pan bolts to specification in the order shown.

CAUTION:

- Installation should be done within 5 minutes after applying liquid gasket.
- Do not fill the engine with oil for at least 30 minutes after the components are installed to allow the sealant to cure.

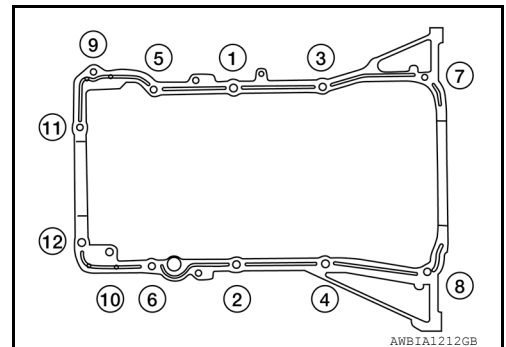

OIL PAN AND OIL STRAINER

< REMOVAL AND INSTALLATION >

7. Install the lower oil pan. Refer to [EM-38, "Removal and Installation \(Lower Oil Pan\)"](#).
8. Installation of the remaining components is in the reverse order of removal.

CAUTION:

- Do not allow crankshaft position sensor (POS) to contact magnet.
- Do not allow foreign material to contact tip of crankshaft position sensor (POS).
- Do not allow foreign material to contact crankshaft position sensor (POS) O-ring.
- Do not use a crankshaft position sensor (POS) that has been dropped.
- Do not use an oil pressure sensor that has been dropped.

INSPECTION AFTER INSTALLATION

- Before starting engine, check oil/fluid levels including engine coolant and engine oil. If there is less than required quantity, fill to the specified level. Refer to [MA-11, "Fluids and Lubricants"](#).
- Use procedure below to check for fuel leakage.
- Turn ignition switch ON (with engine stopped). With fuel pressure applied to fuel piping, check for fuel leakage at connection points.
- Start engine. With engine speed increased, check again for fuel leakage at connection points.
- Run engine to check for unusual noise and vibration.

NOTE:

If hydraulic pressure inside timing chain tensioner drops after removal and installation, slack in the guide may generate a pounding noise during and just after engine start. However, this is normal. Noise will stop after hydraulic pressure rises.

- Warm up engine thoroughly to make sure there is no leakage of fuel, exhaust gas, or any oils/fluids including engine oil and engine coolant.
- Bleed air from passages in lines and hoses, such as in cooling system.
- After cooling down engine, again check oil/fluid levels including engine oil and engine coolant. Refill to specified level, if necessary.
- Summary of the inspection items:

Item		Before starting engine	Engine running	After engine stopped
Engine coolant		Level	Leakage	Level
Engine oil		Level	Leakage	Level
Transmission/ transaxle fluid	A/T and CVT Models	Leakage	Level/Leakage	Leakage
	M/T Models	Level/Leakage	Leakage	Level/Leakage
Other oils and fluids*		Level	Leakage	Level
Fuel		Leakage	Leakage	Leakage
Exhaust gas		—	Leakage	—

*Power steering fluid, brake fluid, etc.

IGNITION COIL

< REMOVAL AND INSTALLATION >

IGNITION COIL

Exploded View

INFOID:000000011220650

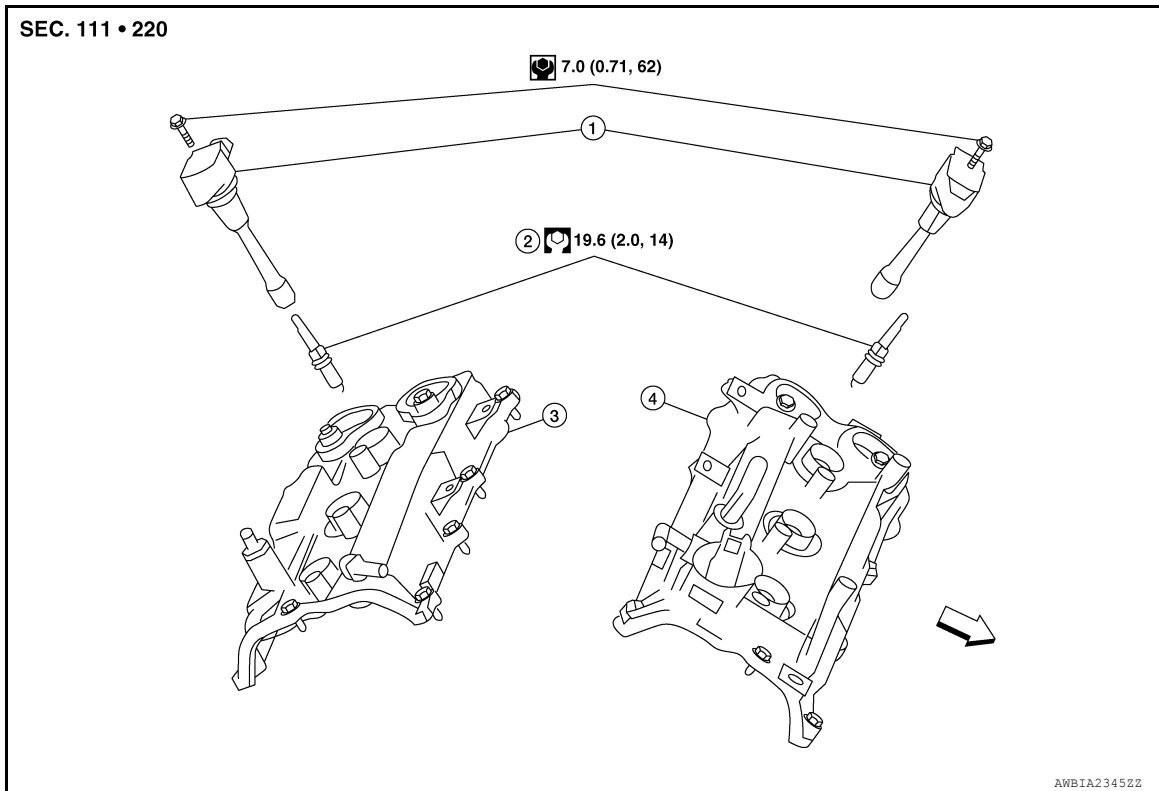

- | | | |
|--------------------------|---------------|--------------------------|
| 1. Ignition coil | 2. Spark plug | 3. Rocker cover (Bank 1) |
| 4. Rocker cover (Bank 2) | ← Front | |

Removal and Installation (bank 2)

INFOID:000000011220651

REMOVAL

1. Remove engine room cover. Refer to [EM-25, "Removal and Installation"](#).
2. Disconnect ignition coil harness connector.
3. Remove the ignition coil.

CAUTION:
Do not shock ignition coil.

INSTALLATION

Installation is in the reverse order of removal.

Removal and Installation (bank 1)

INFOID:000000011220652

REMOVAL

1. Remove the intake manifold collector. Refer to [EM-28, "Removal and Installation"](#).
2. Disconnect ignition coil harness connector.
3. Remove the ignition coil.

CAUTION:
Do not shock ignition coil.

INSTALLATION

Installation is in the reverse order of removal.

ROCKER COVER

< REMOVAL AND INSTALLATION >

ROCKER COVER

Exploded View

INFOID:0000000011220653

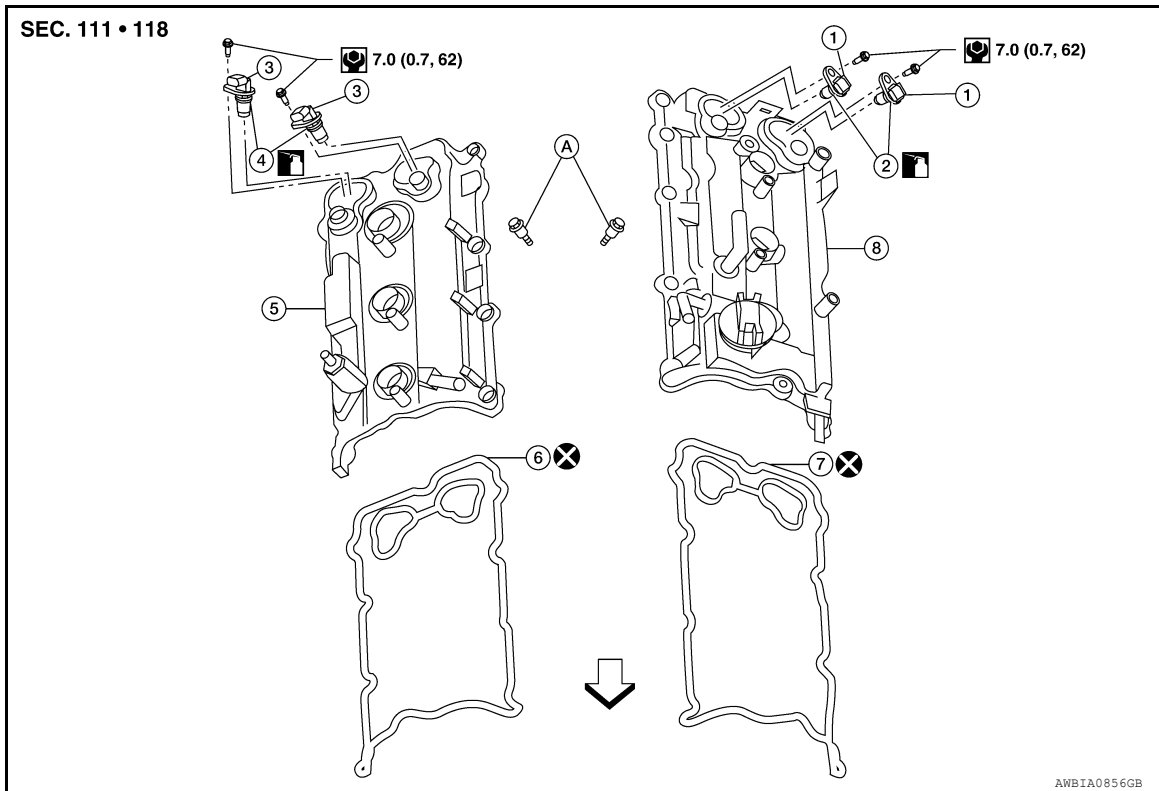

- | | | |
|--------------------------------------|--------------------------|--------------------------------------|
| 1. Camshaft position sensor (Bank 2) | 2. O-rings | 3. Camshaft position sensor (Bank 1) |
| 4. O-rings | 5. Rocker cover (Bank 1) | 6. Rocker cover gasket (Bank 1) |
| 7. Rocker cover gasket (Bank 2) | 8. Rocker cover (Bank 2) | A. Refer to INSTALLATION |
- ⇐ Engine front

Removal and Installation (bank 2)

INFOID:0000000011220654

REMOVAL

1. Remove the engine room cover. Refer to [EM-25. "Removal and Installation"](#).
2. Disconnect air fuel ratio sensor 1 (bank 2) harness connector from air fuel ratio sensor 1 (bank 2).
3. Remove blow by hose from rocker cover.
4. Remove camshaft position sensors.

CAUTION:

- Handle carefully to avoid dropping and shocks.
- Do not disassemble.
- Do not allow metal powder to adhere to magnetic part at sensor tip (A).
- Do not place sensors in a location where they are exposed to magnetism.

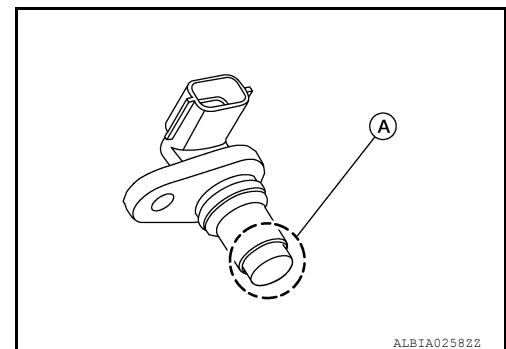

5. Unclip the camshaft position sensor harness retainers.
6. Remove the ignition coils. Refer to [EM-44. "Removal and Installation \(bank 2\)"](#).

CAUTION:

ROCKER COVER

< REMOVAL AND INSTALLATION >

Do not shock ignition coils.

- Remove rocker cover bolts from cylinder head in the reverse order shown.

↔ : Engine front

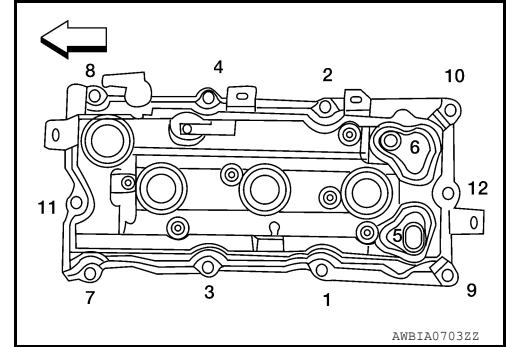

- Remove the rocker cover and gasket.
- Remove the oil filler cap from the rocker cover, (if necessary).

INSTALLATION

Installation is in the reverse order of removal.

CAUTION:

- Do not reuse rocker cover gasket.
- Blow by hose clamps should be installed facing upwards.
- Install press fit hoses so that the white mark faces the rib of the connector.
- Apply sealant to the areas on the front corners using Tool.
- Use Genuine Silicone RTV Sealant or equivalent. Refer to [GI-22, "Recommended Chemical Products and Sealants"](#).

Tool number : WS39930000 (—)

CAUTION:

- Installation should be done within 5 minutes after applying liquid gasket.
- Do not fill the engine with engine oil for at least 30 minutes after the components are installed to allow the sealant to cure.

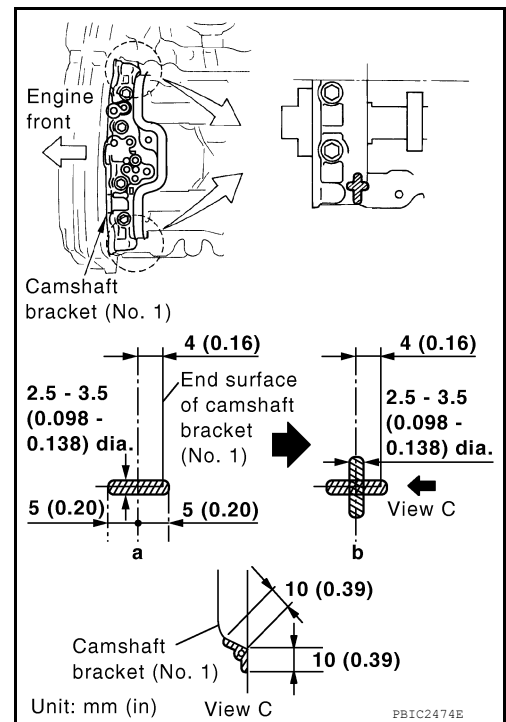

- Tighten the rocker cover bolts to specification in two steps in order shown.

↔ : Engine front

Rocker cover bolts

Step 1 : 1.96 N·m (0.20 kg-m, 17 in-lb)

Step 2 : 8.33 N·m (0.85 kg-m, 74 in-lb)

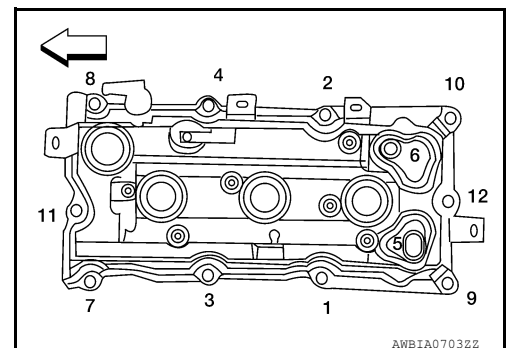

ROCKER COVER

< REMOVAL AND INSTALLATION >

Removal and Installation (bank 1)

INFOID:000000011220655

REMOVAL

1. Remove the engine room cover. Refer to [EM-25, "Removal and Installation"](#).
2. Disconnect air fuel ratio sensor 1 (bank 1) harness connector from air fuel ratio sensor 1 (bank 1).
3. Remove the front air duct and air duct hose and resonator assembly. Refer to [EM-26, "Removal and Installation"](#).
4. Remove the intake manifold collector. Refer to [EM-28, "Removal and Installation"](#).
5. Remove camshaft position sensors.

CAUTION:

- Handle carefully to avoid dropping and shocks.
- Do not disassemble.
- Do not allow metal powder to adhere to magnetic part at sensor tip (A).
- Do not place sensors in a location where they are exposed to magnetism.

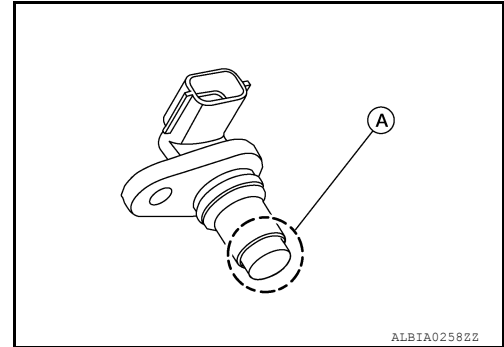

6. Disconnect the PCV hose from the rocker cover.
7. Disconnect the ignition coil harness connectors.
8. Remove ignition coils. Refer to [EM-44, "Removal and Installation \(bank 2\)"](#) and [EM-44, "Removal and Installation \(bank 1\)"](#).

CAUTION:

Do not shock ignition coils.

9. Remove rocker cover bolts from cylinder head in the reverse order shown.

← : Engine front

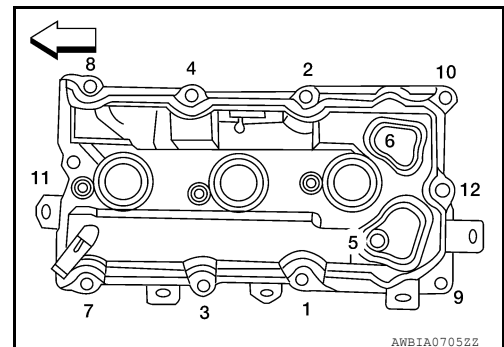

10. Remove the rocker cover and gasket.

INSTALLATION

Installation is in the reverse order of removal.

CAUTION:

- Do not reuse rocker cover gasket.
- Blow by hose clamps should be installed facing upwards.
- Install press fit hoses so that the white mark faces the rib of the connector.

ROCKER COVER

< REMOVAL AND INSTALLATION >

- Apply sealant to the areas on the front corners using Tool.
- Use Genuine Silicone RTV Sealant or equivalent. Refer to [GI-22](#), "[Recommended Chemical Products and Sealants](#)".

Tool number : WS39930000 (—)

CAUTION:

- Installation should be done within 5 minutes after applying liquid gasket.
- Do not fill the engine with engine oil for at least 30 minutes after the components are installed to allow the sealant to cure.

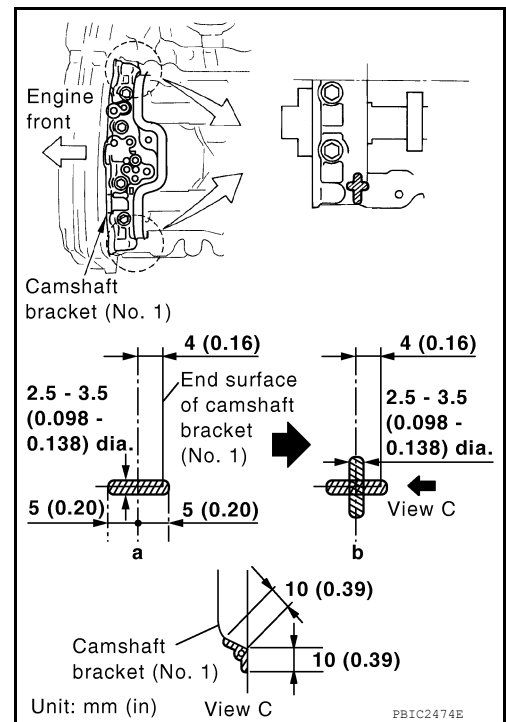

- Tighten the rocker cover bolts in two steps in order as shown.

← : Engine front

Rocker cover bolts

Step 1 : 1.96 N·m (0.20 kg-m, 17 in-lb)

Step 2 : 8.33 N·m (0.85 kg-m, 74 in-lb)

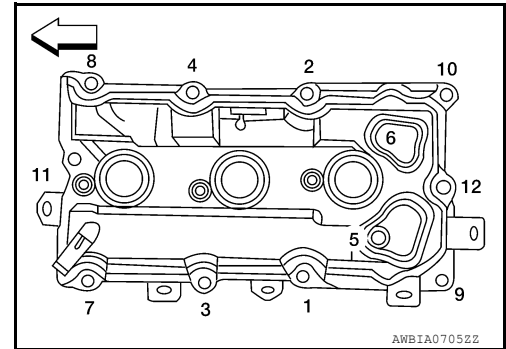

FUEL INJECTOR AND FUEL TUBE

< REMOVAL AND INSTALLATION >

FUEL INJECTOR AND FUEL TUBE

Exploded View

INFOID:000000011220656

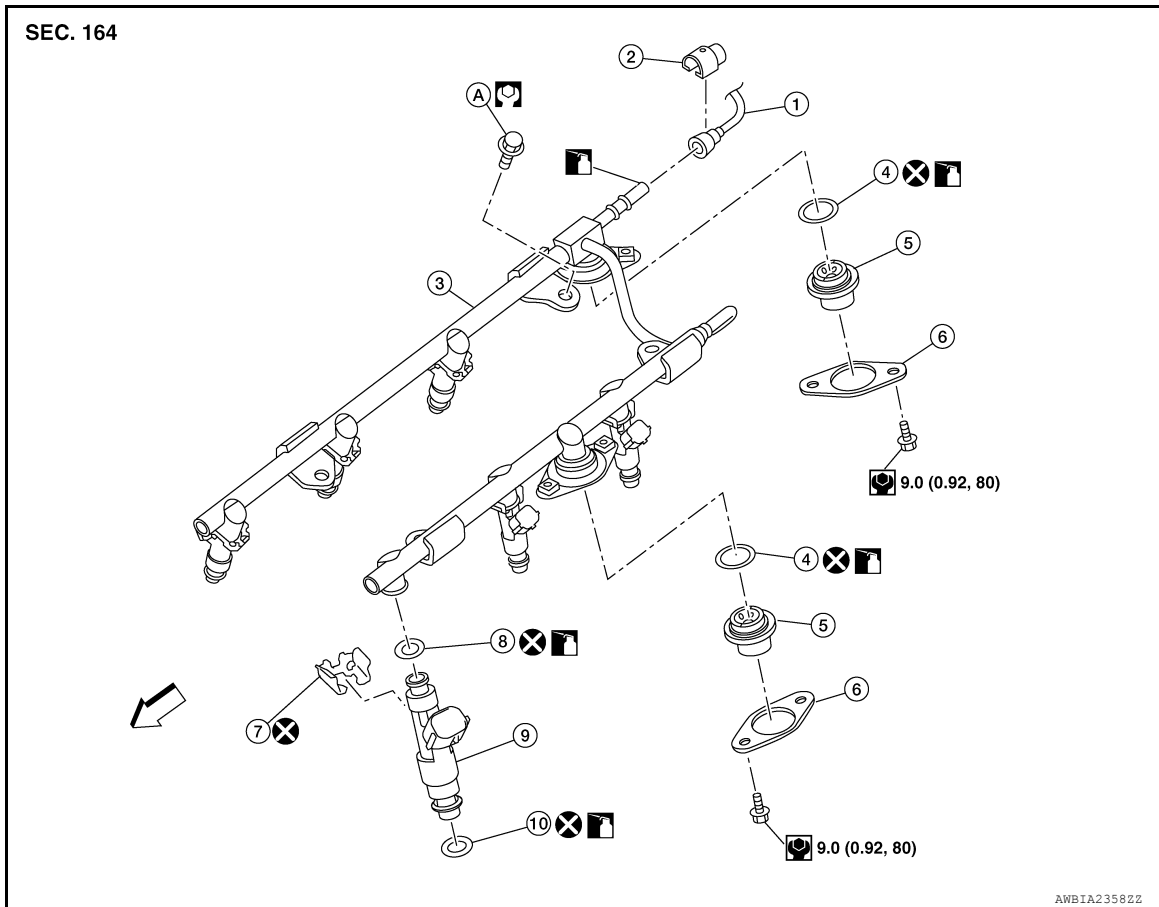

- | | | |
|--------------------|--------------------------|--------------------|
| 1. Fuel feed hose | 2. Quick connector cap | 3. Fuel tube |
| 4. O-ring | 5. Fuel damper | 6. Fuel damper cap |
| 7. Clip | 8. O-ring (black) | 9. Fuel injector |
| 10. O-ring (green) | A. Refer to INSTALLATION | ⇐ Engine front |

Removal and Installation

INFOID:000000011220657

REMOVAL

WARNING:

- Put a "CAUTION: FLAMMABLE" sign in the workshop.
- Be sure to work in a well ventilated area and furnish workshop with a CO₂ fire extinguisher.
- Do not smoke while servicing fuel system. Keep open flames and sparks away from the work area.
- Do not drain engine coolant when engine is hot to avoid the danger of being scalded.

CAUTION:

- Apply new engine oil when installing the parts as specified to do so.
- Do not remove or disassemble parts unless instructed.

NOTE:

When removing components such as hoses, tubes/lines, etc., cap or plug openings to prevent fluid from spilling.

1. Remove engine room cover. Refer to [EM-25. "Removal and Installation"](#).
2. Release the fuel pressure. Refer to [EC-166. "Work Procedure"](#).
3. Disconnect the battery negative terminal. Refer to [PG-86. "Exploded View"](#).
4. Remove intake manifold collector. Refer to [EM-28. "Removal and Installation"](#).

FUEL INJECTOR AND FUEL TUBE

< REMOVAL AND INSTALLATION >

5. When separating fuel feed hose and fuel tube connection, disconnect quick connector using tool as follows:

Tool number : 16441 6N210 (J-45488)

- a. Remove quick connector cap from quick connector.
- b. Disconnect quick connector from fuel tube as follows:

CAUTION:

Disconnect quick connector by using the special service tool, not by prying out retainer tabs.

- i. With the sleeve side of tool facing toward the quick connector, install the tool onto fuel tube.
- ii. Insert the tool (A) into quick connector (2) until sleeve (B) contacts and goes no further. Hold tool in that position.

(C) : Insert and retain

CAUTION:

Inserting tool with excess force will not disconnect quick connector. Hold quick connector release where it contacts and goes no further.

- iii. Draw and pull out quick connector straight from fuel tube (1).

CAUTION:

- Pull quick connector (E) holding position (D) as shown.
- Do not pull with lateral force applied. O-ring inside quick connector may be damaged.
- Prepare container and cloth beforehand as fuel will leak out.
- Avoid fire and sparks.
- Keep parts away from heat source. Be especially careful when welding is performed around them.
- Do not expose parts to battery electrolyte or other acids.
- Do not bend or twist connection between quick connector and fuel feed hose (with damper) during installation/removal.
- To keep the connecting portion clean and to avoid damage and foreign materials, cover them completely with plastic bags (A) or something similar.

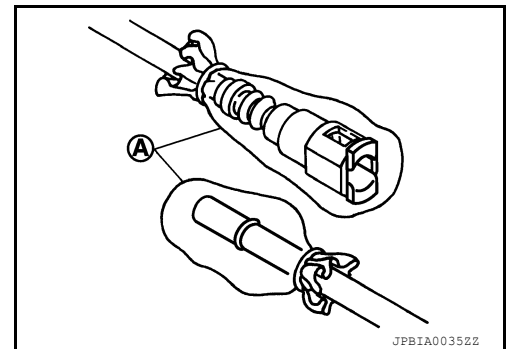
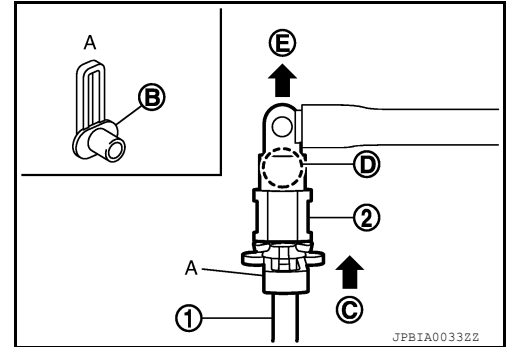

6. Disconnect harness connector from fuel injector.
7. Loosen bolts in reverse order as shown, and remove fuel tube and fuel injector assembly.

← : Engine front

CAUTION:

Do not tilt fuel tube or remaining fuel in pipes may flow out from pipes.

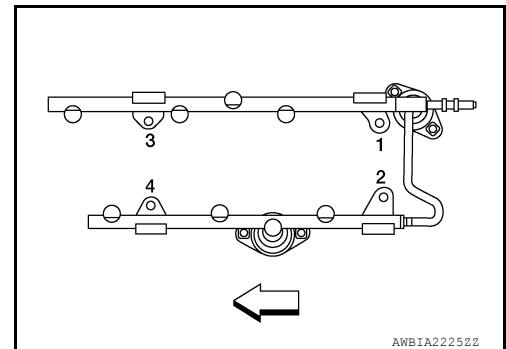

8. Remove fuel injector from fuel tube as follows:

FUEL INJECTOR AND FUEL TUBE

< REMOVAL AND INSTALLATION >

- a. Open and remove clip (1).

- (3) : O-ring (green)
(4) : O-ring (black)
(A) : Installed condition
(B) : Clip mounting groove

- b. Remove fuel injector (2) from fuel tube (5) by pulling straight.

CAUTION:

- Be careful or the remaining fuel in the fuel tube may spill.
- Be careful not to damage injector nozzle during removal.
- Do not bump or drop fuel injector.
- Do not disassemble fuel injector.
- Do not reuse O-rings.

9. Remove fuel damper from fuel tube.

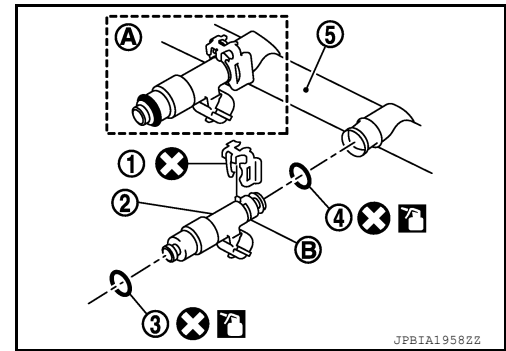

INSTALLATION

1. Install fuel damper as follows:

- a. Install new O-ring (2) to fuel tube (1) as shown. When handling new O-ring, be careful of the following caution:

CAUTION:

- Do not reuse O-rings.
- Handle O-ring with bare hands. Do not wear gloves.
- Lubricate O-ring with new engine oil.
- Do not clean O-ring with solvent.
- Check that O-ring and its mating part are free of foreign material.
- When installing O-ring, be careful not to scratch, nick or damage it. Also be careful not to twist or stretch O-ring.
- Insert new O-ring straight into fuel tube. Be sure O-ring is centered and not twisted.

- b. Install spacer (3) to fuel damper (4).

- c. Insert fuel damper straight into fuel tube.

CAUTION:

- Insert fuel damper until (B) is touching (A) of fuel tube.
- Insert straight, checking that the axis is lined up.
- Do not pressure-fit with excessive force.

Reference value : 130 N (13.3 kg, 29.2 lb)

- d. Tighten bolts evenly in turn.

- After tightening bolts, check that there is no gap between fuel damper cap (5) and fuel tube.

2. Install new O-rings to fuel injector paying attention to the following.

CAUTION:

- Do not reuse O-rings.
- Upper and lower O-ring are different. Be careful to install them in the correct location.
- Handle O-ring with bare hands. Do not wear gloves.
- Lubricate O-ring with new engine oil.
- Do not clean O-ring with solvent.
- Check that O-ring and its mating part are free of foreign material.
- When installing O-ring, be careful not to scratch or nick it. Also be careful not to twist or stretch O-ring.
- Insert O-ring straight into fuel injector. Be sure that the O-ring is centered and not twisted.

3. Install fuel injector to fuel tube as follows:

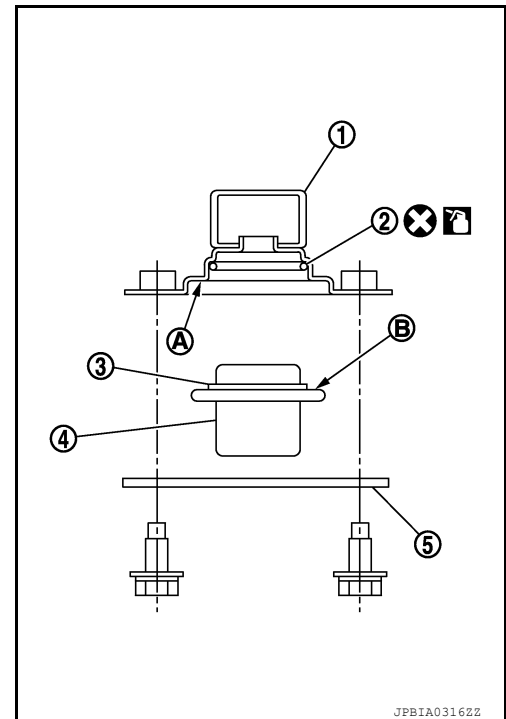

FUEL INJECTOR AND FUEL TUBE

< REMOVAL AND INSTALLATION >

a. Insert clip (3) into clip groove (F) on fuel injector (5).

(2) : O-ring (black)

(4) : O-ring (green)

- Insert clip so that protrusion (E) of fuel injector matches cutout (C) of clip.

CAUTION:

- Do not reuse clip. Replace it with new one.
- Be careful to keep clip from interfering with O-ring. If interference occurs, replace O-ring.
- Do not reuse O-rings.

b. Insert fuel injector into fuel tube (1) with clip attached.

- Insert it while matching it to the axial center.
- Insert fuel injector so that protrusion (A) of fuel tube matches cutout (B) of clip.
- Check that fuel tube flange (G) is securely fixed in flange groove (D) on clip.

CAUTION:

Do not pressure-fit with excessive force.

Reference value : 147 N (15.0 kg, 33.0 lb)

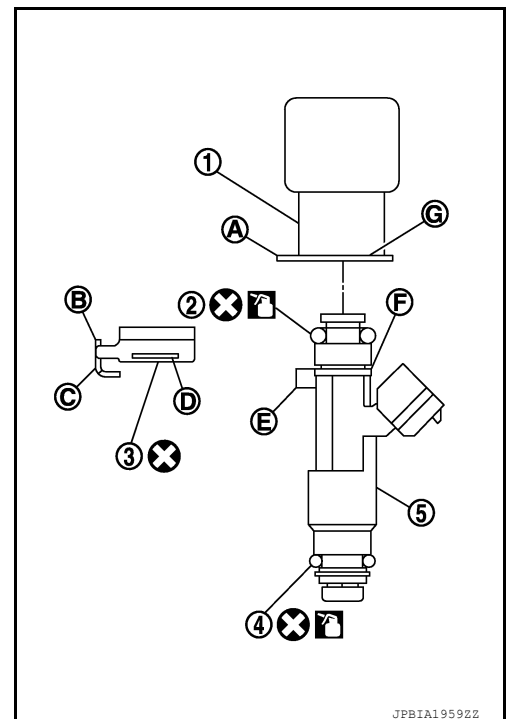

c. Check that installation is complete by checking that fuel injector does not rotate or come off.

- Check that protrusions of fuel injectors and fuel tubes are aligned with cutouts of clips after installation.

4. Install fuel tube and fuel injector assembly to intake manifold.

CAUTION:

Be careful not to let tip of injector nozzle come in contact with other parts.

- Tighten bolts in two steps in numerical order as shown.

⇐ : Engine front

1st step : 10.1 N·m (1.0 kg-m, 7 ft-lb)

2nd step : 22.0 N·m (2.2 kg-m, 16 ft-lb)

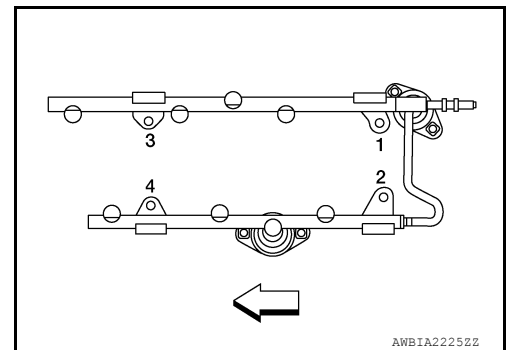

5. Connect fuel injector harness.

6. Install intake manifold collector. Refer to [EM-28, "Removal and Installation"](#).

7. Connect quick connector between fuel feed hose and fuel tube connection with the following procedure:

a. Check no foreign substances are on the fuel tube or quick connector and that they are not damaged.

b. Apply a light coating of new engine oil around fuel tube from tip end to spool end.

c. Align center to insert quick connector straightly into fuel tube.

- Insert quick connector (1) to fuel tube until top spool (2) is completely inside quick connector, and 2nd level spool (3) exposes right below quick connector.

(B) : Installed condition

⇐ : Upright insertion

CAUTION:

- Hold (A) position as shown when inserting fuel tube into quick connector.
- Carefully align center to avoid inclined insertion to prevent damage to O-ring inside quick connector.

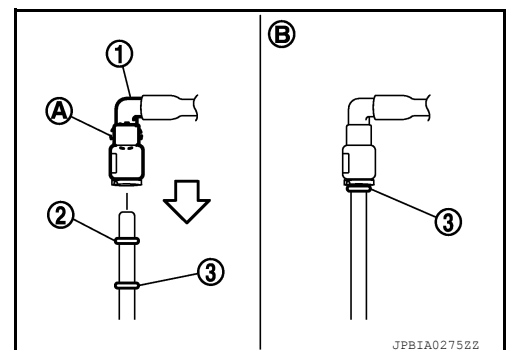

FUEL INJECTOR AND FUEL TUBE

< REMOVAL AND INSTALLATION >

- **Insert until you hear a “click” sound and actually feel the engagement.**
 - **To avoid misidentification of engagement with a similar sound, be sure to perform the next step.**
- d. Pull quick connector by hand holding position. Check it is completely engaged (connected) so that it does not come out from fuel tube.
 - e. Install quick connector cap (3) to quick connector.

- (1) : Fuel feed hose
(2) : Fuel tube
(B) : Upper view

- Install quick connector cap with arrow (A) on surface facing in direction of quick connector (fuel feed hose side).

CAUTION:

If quick connector cap cannot be installed smoothly, quick connector may have not been installed correctly. Check connection again.

- f. Secure fuel feed hose to clamp of quick connector cap.
- g. Installation of the remaining components is in the reverse order of removal.

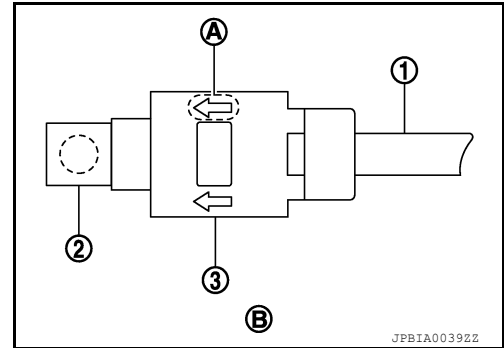

Inspection

INFOID:000000011220658

INSPECTION AFTER INSTALLATION

Check For Fuel Leaks

1. Turn ignition switch ON with the engine stopped. With fuel pressure applied to fuel piping, check for fuel leaks at connection points. Repair as necessary.

NOTE:

Use mirrors for checking at points out of clear sight.

2. Start the engine. With engine speed increased, check again for fuel leaks at connection points. Repair as necessary.

WARNING:

Do not touch the engine immediately after stopped, as the engine becomes extremely hot.

NOTE:

Use mirrors for checking on connections out of the direct line of sight.

- Perform procedures for “Throttle Valve Closed Position Learning” after finishing repairs. Refer to [EC-157, "Work Procedure"](#).
- If electric throttle control actuator is replaced, perform procedures for “Idle Air Volume Learning” after finishing repairs. Refer to [EC-158, "Work Procedure"](#).

VALVE TIMING CONTROL

< REMOVAL AND INSTALLATION >

VALVE TIMING CONTROL

Exploded View

INFOID:000000011545380

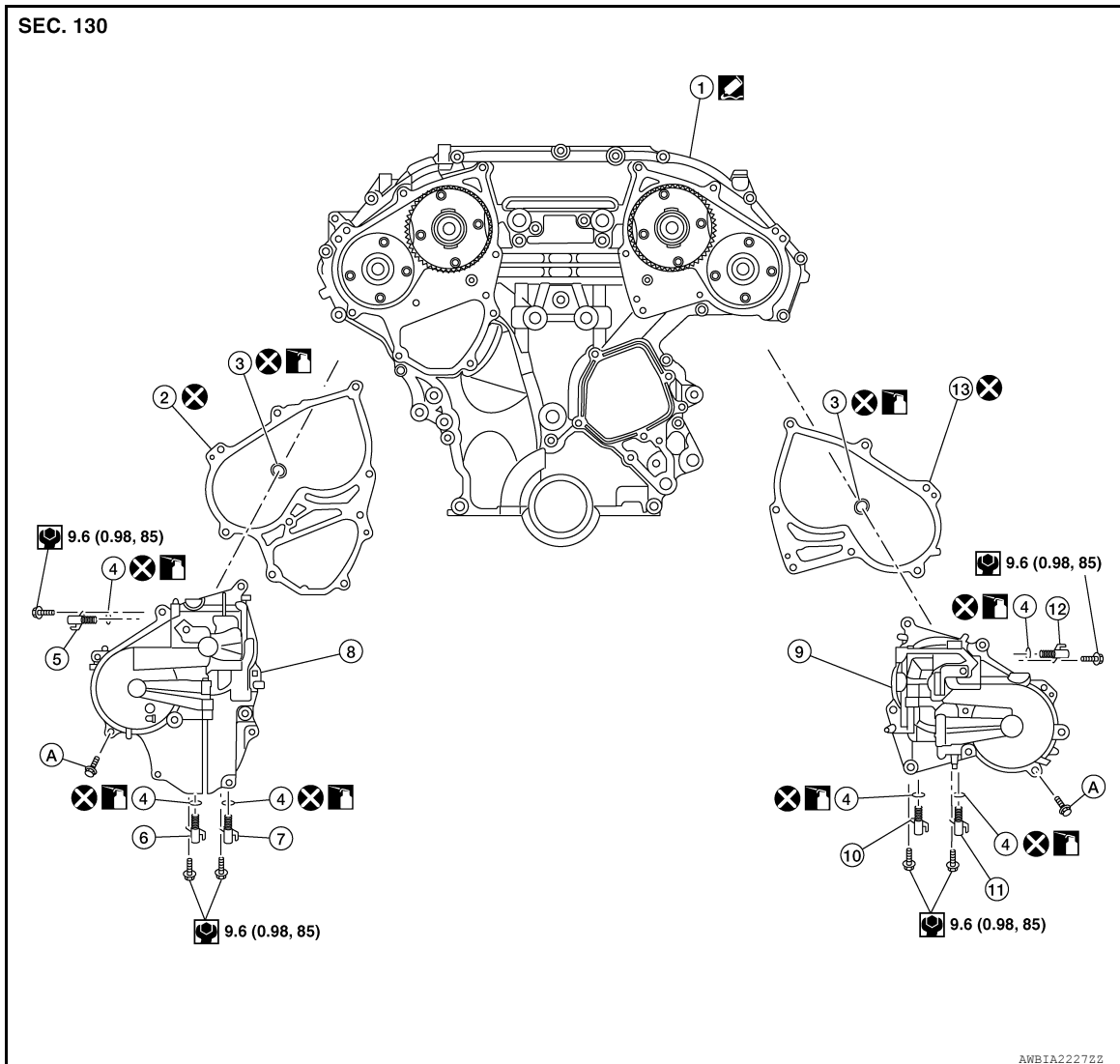

- | | | |
|--|--|---|
| 1. Front timing chain case | 2. Valve timing control cover gasket (bank 1) | 3. O-ring |
| 4. O-ring | 5. Intake valve timing intermediate lock control solenoid valve (bank 1) | 6. Exhaust valve timing control solenoid valve (bank 1) |
| 7. Intake valve timing control solenoid valve (bank 1) | 8. Valve timing control cover (bank 1) | 9. Valve timing control cover (bank 2) |
| 10. Intake valve timing control solenoid (bank 2) | 11. Exhaust valve timing control solenoid (bank 2) | 12. Intake valve timing intermediate lock control solenoid valve (bank 2) |
| 13. Valve timing control cover gasket (bank 2) | A. Refer to INSTALLATION | |

Valve Timing Control Cover (bank 1)

INFOID:000000011545381

REMOVAL

1. Disconnect battery negative terminal. Refer to [PG-90, "Exploded View"](#).
2. Remove core support cover. Refer to [EXT-30, "Exploded View"](#).

VALVE TIMING CONTROL

< REMOVAL AND INSTALLATION >

3. Remove front air duct. Refer to [EM-26, "Exploded View"](#).
4. Remove cowl top and cowl top extension. Refer to [EXT-34, "Exploded View"](#).
5. Remove reservoir tank. Refer to [CO-13, "Exploded View"](#).
6. Remove power steering oil pump. Refer to [ST-38, "Removal and Installation"](#).
7. Support engine (1) and transaxle (2) using suitable jack (A).

CAUTION:

- Position a suitable jack under the engine and transaxle assembly as shown.
- Do not damage the front exhaust tube or transaxle oil pan with the jack.

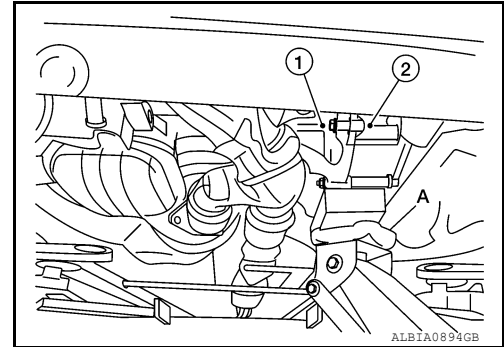

8. Remove upper torque rod, engine mounting insulator (RH), and engine mounting bracket (RH). Refer to [EM-104, "FWD : Exploded View"](#) (FWD) or [EM-108, "AWD : Exploded View"](#) (AWD).
9. Disconnect intake valve timing intermediate lock control solenoid valve (bank 1) harness connector.
10. Disconnect exhaust valve timing control solenoid valve (bank 1) harness connector.
11. Disconnect intake valve timing control solenoid valve (bank 1) harness connector.
12. Remove intake valve timing intermediate lock control solenoid valve (bank 1), exhaust valve timing control solenoid valve (bank 1), and intake valve timing control solenoid valve (bank 1) from valve timing control cover (bank 1).

CAUTION:

Do not reuse O-rings.

INSTALLATION

- Install valve timing control cover (bank 1). Refer to [EM-54, "Exploded View"](#).
- Installation of remaining components is in the reverse order of removal.

CAUTION:

- Do not reuse valve timing control cover gasket.
- Do not reuse O-rings.
- Lubricate O-rings with clean engine oil prior to installation.

Valve Timing Control Cover (bank 2)

INFOID:0000000011545382

REMOVAL

1. Remove core support cover. Refer to [EXT-30, "Exploded View"](#).
2. Remove front air duct. Refer to [EM-26, "Removal and Installation"](#).
3. Remove reservoir tank. Refer to [CO-13, "Exploded View"](#).
4. Remove power steering oil pump. Refer to [ST-38, "Removal and Installation"](#).
5. Disconnect intake valve timing intermediate lock control solenoid valve (bank 2) harness connector.
6. Disconnect exhaust valve timing control solenoid valve (bank 2) harness connector.
7. Disconnect intake valve timing control solenoid valve (bank 2) harness connector.
8. Remove intake valve timing intermediate lock control solenoid valve (bank 2), exhaust valve timing control solenoid valve (bank 2), and intake valve timing control solenoid valve (bank 2) from valve timing control cover (bank 2).

CAUTION:

Do not reuse O-rings.

9. Remove valve timing control cover and valve timing control cover gasket.

INSTALLATION

- Install valve timing control cover (bank 2). Refer to [EM-54, "Exploded View"](#).
- Installation of remaining components is in the reverse order of removal.

CAUTION:

- Do not reuse valve timing control cover gasket.

VALVE TIMING CONTROL

< REMOVAL AND INSTALLATION >

- **Do not reuse O-rings.**
- **Lubricate O-rings with clean engine oil prior to installation.**

FRONT TIMING CHAIN CASE

< REMOVAL AND INSTALLATION >

FRONT TIMING CHAIN CASE

Exploded View

INFOID:000000011545423

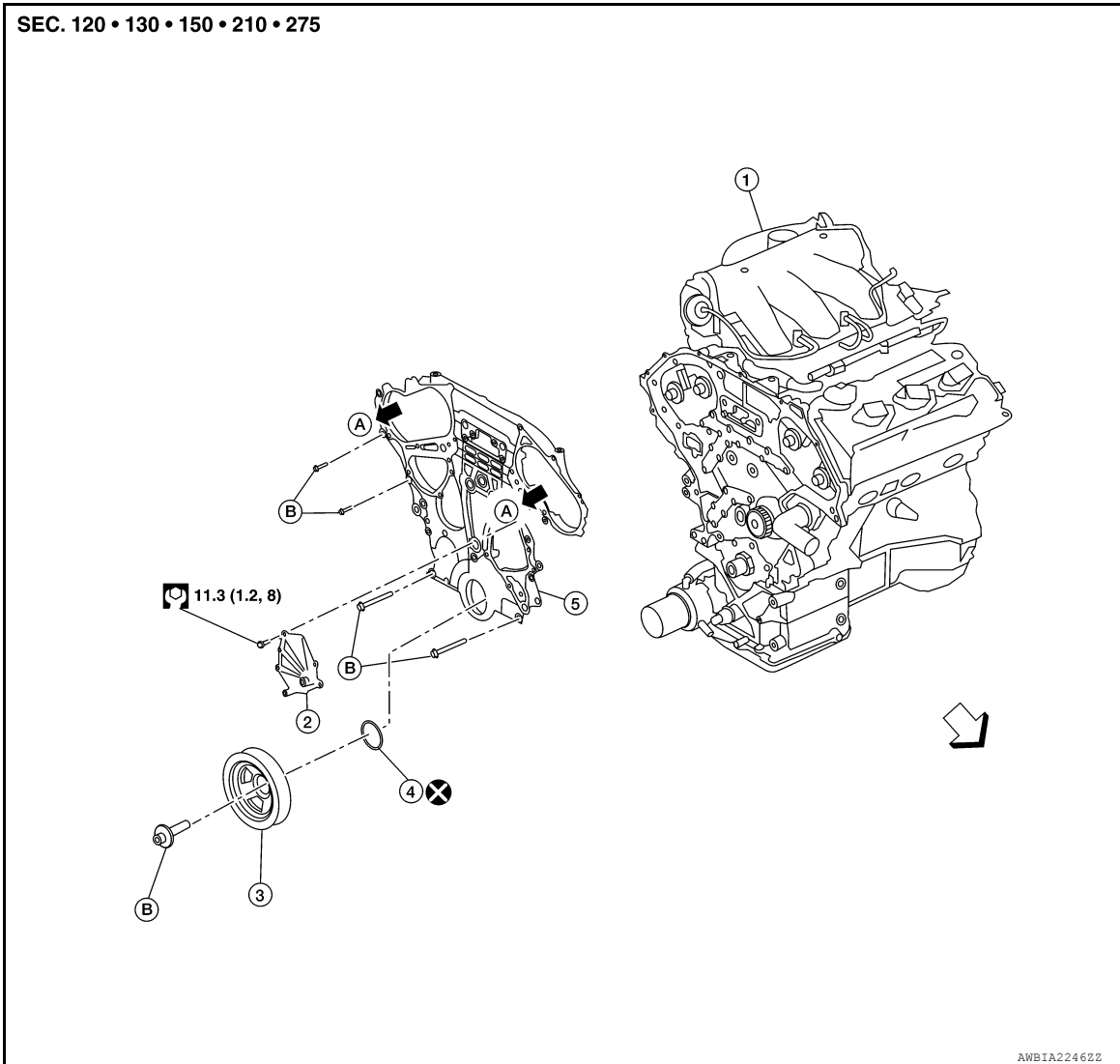

- | | | |
|--------------------------|----------------------------|--|
| 1. Engine assembly | 2. Water pump cover | 3. Crankshaft pulley |
| 4. Front oil seal | 5. Front timing chain case | A. To Valve timing control cover (bank 1/ bank 2). Refer to EM-54. "Exploded View" |
| B. Refer to INSTALLATION | ⇐ Front | |

Removal and Installation

INFOID:000000011545424

NOTE:

- This section describes the procedure for removal/installation of the front timing chain case without removing the engine from the vehicle.
- When rear timing chain case must be removed, remove the engine from the vehicle. Refer to [EM-104. "FWD : Removal and Installation"](#) (FWD) or [EM-109. "AWD : Removal and Installation"](#) (AWD). Then remove front timing chain case, timing chain related parts, and rear timing chain case in this order, and install in reverse order of removal.
- When removing components such as hoses, tubes/lines, etc., cap or plug openings to prevent fluid from spilling.

REMOVAL

FRONT TIMING CHAIN CASE

< REMOVAL AND INSTALLATION >

1. Remove engine under cover. Refer to [EM-25, "Removal and Installation"](#).
2. Drain the engine coolant from the radiator. Refer to [CO-9, "Changing Engine Coolant"](#).
3. Drain the engine oil. Refer to [LU-9, "Changing Engine Oil"](#).
4. Drain the power steering fluid. Refer to [ST-30, "Draining and Refilling"](#).
5. Remove engine room cover. Refer to [EM-25, "Removal and Installation"](#).
6. Remove front air duct. Refer to [EM-26, "Exploded View"](#).
7. Remove battery tray. Refer to [PG-88, "Removal and Installation"](#).
8. Remove cowl top. Refer to [EXT-34, "Exploded View"](#).
9. Remove upper radiator hose.
10. Disconnect engine coolant reservoir hose from the radiator and remove engine coolant reservoir.
11. Remove cooling fan assembly. Refer to [CO-15, "Removal and Installation"](#).
12. Disconnect lower radiator hose from engine.
13. Remove the radiator. Refer to [CO-13, "Removal and Installation"](#).
14. Disconnect the power steering fluid reservoir tank hose from the power steering pump and fluid cooler and remove the power steering fluid reservoir tank.
15. Remove the front wheel and tire (RH) using a power tool. Refer to [WT-68, "Removal and Installation"](#).
16. Remove the fender protector side cover (RH). Refer to [EXT-36, "FENDER PROTECTOR : Exploded View"](#).
17. Remove the drive belt. Refer to [EM-14, "Removal and Installation"](#).
18. Remove the rocker covers, if necessary. Refer to [EM-45, "Removal and Installation \(bank 2\)"](#) (bank 2) and [EM-47, "Removal and Installation \(bank 1\)"](#) (bank 1).

NOTE:

Necessary only when removing timing chains.

19. If removing the timing chains, obtain compression TDC of No. 1 cylinder as follows:
 - a. Rotate crankshaft pulley clockwise to align timing mark (grooved line without color) with timing indicator (A).

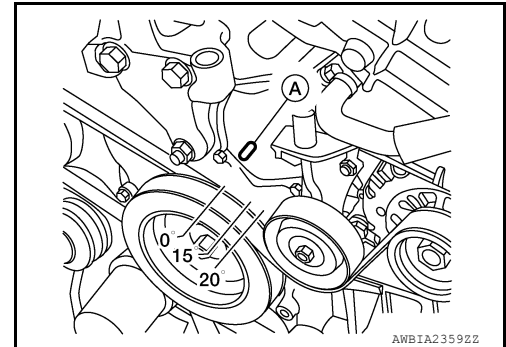

- b. Check that intake and exhaust camshaft lobes on No. 1 cylinder (bank 1) (A) are located as shown.
 - If not, turn the crankshaft one revolution (360°) and align as shown.

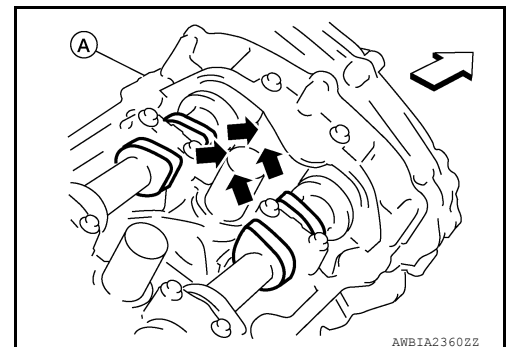

← Engine front

20. Remove the access plate and lock the ring gear using Tool.

Tool number : — (J-50288)

CAUTION:

Do not damage the ring gear teeth, or the signal plate teeth behind the ring gear, when installing Tool.

21. Remove the crankshaft pulley as follows:
 - a. Loosen crankshaft pulley and locate bolt seating surface at 10 mm (0.39 in) from its original position.

FRONT TIMING CHAIN CASE

< REMOVAL AND INSTALLATION >

- b. Position a pulley puller at recess hole of crankshaft pulley to remove crankshaft pulley.

CAUTION:

Do not use a puller claw on crankshaft pulley periphery.

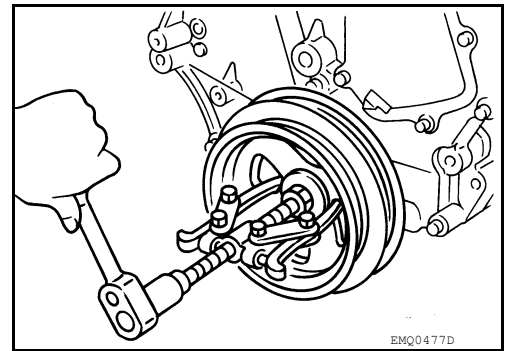

22. Remove the power steering pump. Refer to [ST-38, "Removal and Installation"](#).
 23. Remove the lower oil pan. Refer to [EM-38, "Removal and Installation \(Lower Oil Pan\)"](#).
 24. Remove upper oil pan bolts (1) and (2) as shown. Refer to [EM-39, "Removal and Installation \(Upper Oil Pan\)"](#).

← Engine front

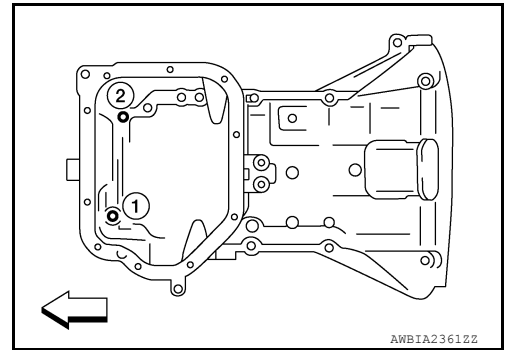

25. Remove the generator. Refer to [CHG-29, "Removal and Installation"](#).
 26. Disconnect the A/C tubes from the A/C compressor and position aside. Refer to [HA-22, "Recycle Refrigerant"](#).
 27. Remove the A/C compressor bolts and the A/C compressor. Refer to [HA-29, "COMPRESSOR : Removal and Installation"](#).
 28. Remove the generator bracket. Refer to [CHG-29, "Exploded View"](#).
 29. Support the engine with suitable jack and remove the RH engine insulator, mount and torque rod. Refer to [EM-104, "FWD : Removal and Installation"](#) (FWD) and [EM-109, "AWD : Removal and Installation"](#) (AWD).
 30. Disconnect the oil pressure switch harness connector.
 31. Disconnect the intake valve timing control solenoid valve harness connector.
 32. Remove the valve timing control cover (bank 1) (A) and valve timing control cover (bank 2) (B).

(C) : Dowel pin hole

- Loosen the intake valve timing control solenoid valve cover bolts in the reverse order as shown.

CAUTION:

The shaft in the intake valve timing control solenoid valve cover is inserted into the center hole of the intake camshaft sprocket. Remove the intake valve timing control solenoid valve cover by pulling straight out until the intake valve timing control solenoid valve cover disengages from the camshaft sprocket.

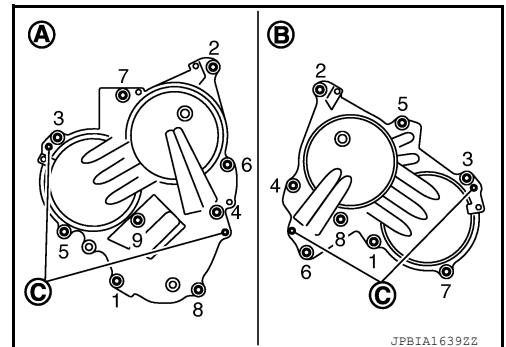

33. Remove the drive belt auto-tensioner. Refer to [EM-16, "Removal and Installation of Drive Belt Auto-tensioner"](#).
 34. If necessary, remove the water pump cover.

FRONT TIMING CHAIN CASE

< REMOVAL AND INSTALLATION >

35. Remove the front timing chain case.

- a. Loosen the front timing chain case bolts in reverse order as shown.

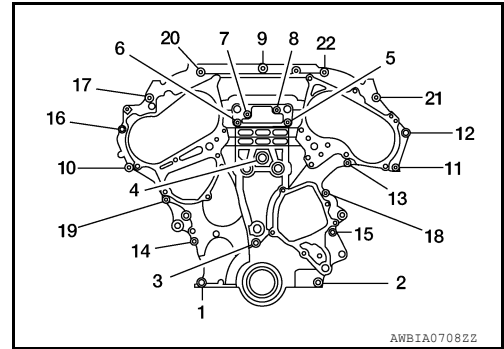

- b. Insert the appropriate size suitable tool into the notch (A) at the top of the front timing chain case as shown.
 c. Pry off the case by moving the suitable tool (B) as shown.
 • Cut liquid gasket for removal using Tool.

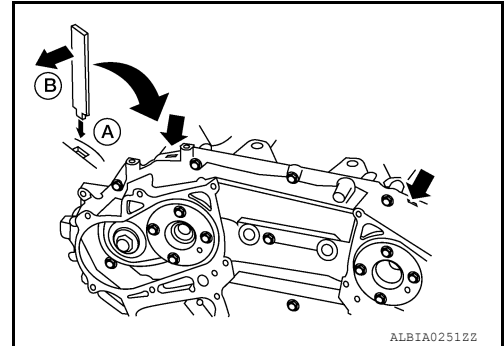

Tool number: KV10111100 (J-37228)

CAUTION:

- Do not use a screwdriver or similar tool.
- After removal, handle carefully so it does not bend, or warp under a load.

36. Remove O-rings (1) from rear timing chain case.

(A) : Bank 1 (RH)

(B) : Bank 2 (LH)

CAUTION:

Do not reuse O-rings.

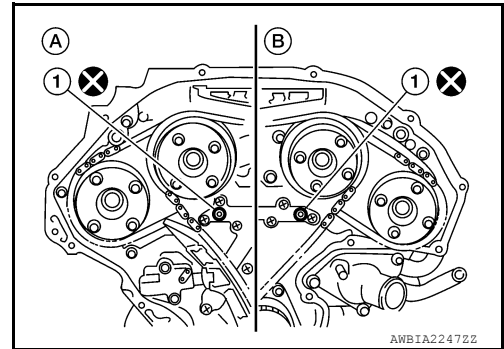

37. Remove the front oil seal from the front timing chain case using suitable tool.

CAUTION:

Do not damage the front cover.

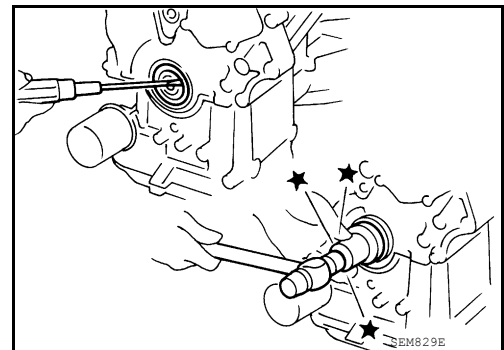

38. Remove all old Silicone RTV Sealant (A) from all the bolt holes (B) and bolts.

CAUTION:

Do not damage the threads or mating surfaces.

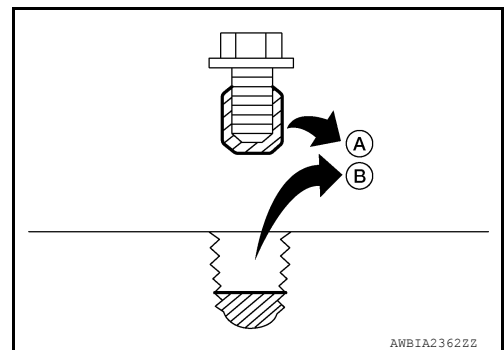

FRONT TIMING CHAIN CASE

< REMOVAL AND INSTALLATION >

39. Use a suitable tool (A) to remove all of the old Silicone RTV Sealant from the front timing chain case (B) and opposite mating surfaces.

CAUTION:

Do not damage the mating surfaces.

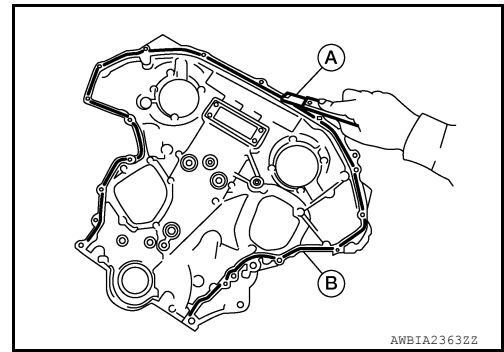

INSTALLATION

1. Install dowel pins (right and left) (A) into front timing chain case up to a point close to taper in order to shorten protrusion length.

NOTE:

Be sure to place the dowel pins in original hole locations in the front timing chain case (B).

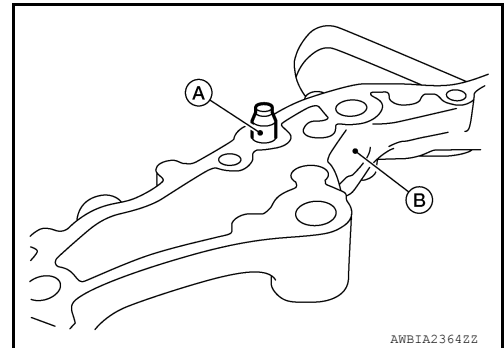

2. Install the new front oil seal on the front timing chain case. Apply new engine oil to the oil seal edges.

NOTE:

Install it so that each seal lip is oriented as shown.

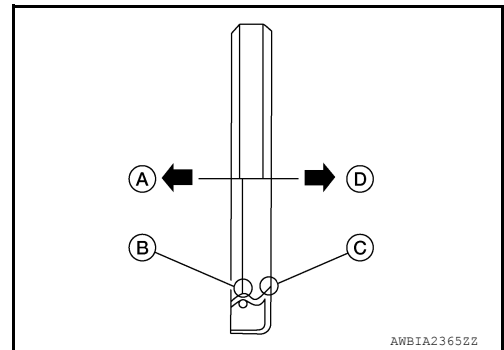

- a. Install the new front oil seal so that it becomes flush with the face with front timing chain case using Tool (A). Refer to [EM-87, "Removal and Installation of Front Oil Seal"](#).

CAUTION:

Press fit straight and avoid causing burrs or tilting the oil seal.

NOTE:

Make sure the garter spring is in position and seal lip is not inverted.

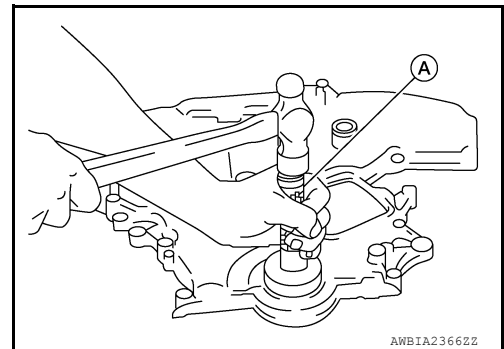

A
EM
C
D
E
F
G
H
I
J
K
L
M
N
O
P

FRONT TIMING CHAIN CASE

< REMOVAL AND INSTALLATION >

3. Install new O-rings (1) on rear timing chain case.

- (A) : Bank 1 (RH)
- (B) : Bank 2 (LH)

CAUTION:
Do not reuse O-rings.

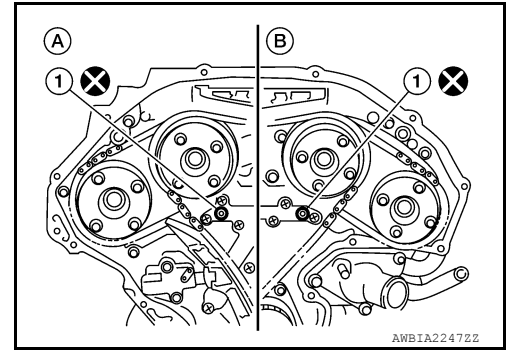

4. Apply Silicone RTV Sealant to front timing chain case as shown.

- Use Genuine Silicone RTV Sealant, or equivalent. Refer to [GI-22. "Recommended Chemical Products and Sealants"](#).
- Before installation, wipe off the protruding sealant.
- (C): 2.6 - 3.6 mm (0.102 - 0.142 in) dia.

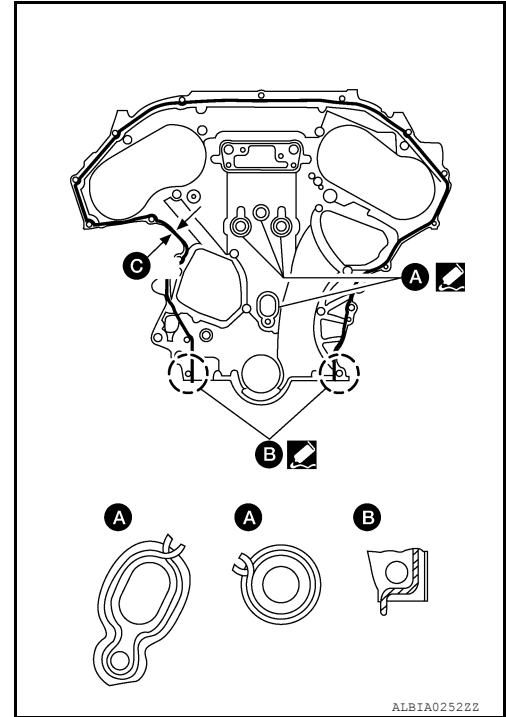

5. Install dowel pin on the front timing chain case into dowel pin hole in the rear timing chain case.

6. Loosely install the front timing chain case bolts.

Bolt position	Bolt diameter
1, 2	: 8 mm (0.31 in)
3 – 22	: 6 mm (0.24 in)

7. Tighten the front timing chain case bolts in the order as shown.
• Retighten the front timing chain case bolts in the order as shown.

Bolt position	Tightening specification
1, 2	: 28.4 N·m (2.9 kg-m, 21 ft-lb)
3 – 22	: 12.7 N·m (1.3 kg-m, 9 ft-lb)

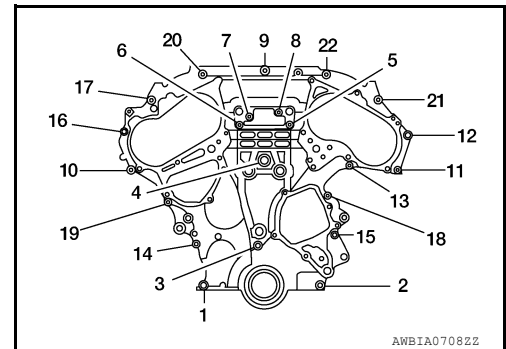

FRONT TIMING CHAIN CASE

< REMOVAL AND INSTALLATION >

8. Install upper oil pan bolts (1) and (2) as shown. Refer to [EM-39. "Removal and Installation \(Upper Oil Pan\)"](#).

⇐ Engine front

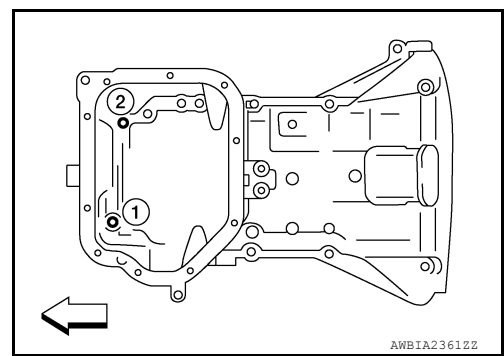

9. Install lower oil pan. Refer to [EM-38. "Removal and Installation \(Lower Oil Pan\)"](#).

10. Install intake valve timing control solenoid valve covers as follows:

- a. Install new O-rings in shaft grooves.

CAUTION:

Do not reuse O-rings.

- b. Being careful not to move O-rings from the installation grooves, align dowel pins on front timing chain case with the holes to install valve timing control covers.

- c. Tighten intake valve timing control solenoid valve cover bolts in numerical order as shown.

- (A) : Bank 1 (RH)
 (B) : Bank 2 (LH)
 (C) : Dowel pin hole

Intake valve timing control solenoid valve cover bolts : 11.3 N·m (1.2 kg-m, 8 ft-lb)

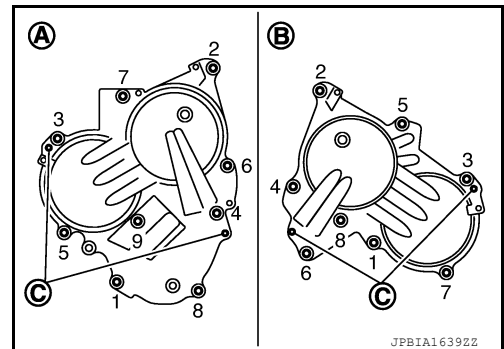

11. Apply liquid gasket and install the water pump cover, if removed.

- Use Genuine Silicone RTV Sealant or equivalent. Refer to [GI-22. "Recommended Chemical Products and Sealants"](#).

12. Install crankshaft pulley and tighten the bolt in two steps.

- Lubricate thread and seat surface of the bolt with new engine oil.
- Apply a paint mark for the second step of angle tightening.

Step 1 : 44 N·m (4.5 kg-m, 32 ft-lb)

Step 2 : 84° - 90° degrees clockwise

Tool Number : KV10112100 (BT-8653-A)

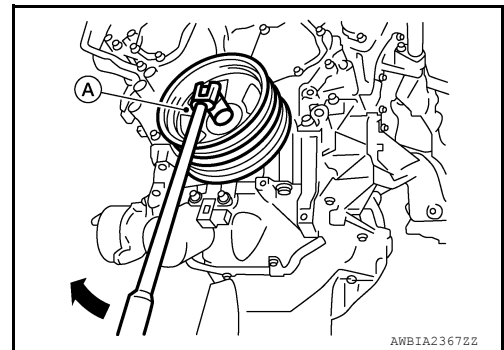

13. Remove Tool and install the access plate.

Tool number : — (J-50288)

CAUTION:

Do not damage the ring gear teeth, or the signal plate teeth behind the ring gear, when removing the Tool.

14. Rotate crankshaft pulley in normal direction (clockwise when viewed from front) to confirm it turns smoothly.

15. Installation of the remaining components is in the reverse order of removal.

INSPECTION AFTER INSTALLATION

FRONT TIMING CHAIN CASE

< REMOVAL AND INSTALLATION >

- Before starting engine, check oil/fluid levels including engine coolant and engine oil. If less than required quantity, fill to the specified level. Refer to [MA-11, "Fluids and Lubricants"](#).
- Use procedure below to check for fuel leakage.
- Turn ignition switch ON (with engine stopped). With fuel pressure applied to fuel piping, check for fuel leakage at connection points.
- Start engine. With engine speed increased, check again for fuel leakage at connection points.
- Run engine to check for unusual noise and vibration.

NOTE:

If hydraulic pressure inside timing chain tensioner drops after removal and installation, slack in the guide may generate a pounding noise during and just after engine start. However, this is normal. Noise will stop after hydraulic pressure rises.

- Warm up engine thoroughly to make sure there is no leakage of fuel, exhaust gas, or any oils/fluids including engine oil and engine coolant.
- Bleed air from passages in lines and hoses, such as in cooling system.
- After cooling down engine, again check oil/fluid levels including engine oil and engine coolant. Refill to specified level, if necessary.
- Summary of the inspection items:

Item		Before starting engine	Engine running	After engine stopped
Engine coolant		Level	Leakage	Level
Engine oil		Level	Leakage	Level
Transmission/ transaxle fluid	A/T and CVT Models	Leakage	Level/Leakage	Leakage
	M/T Models	Level/Leakage	Leakage	Level/Leakage
Other oils and fluids*		Level	Leakage	Level
Fuel		Leakage	Leakage	Leakage
Exhaust gas		—	Leakage	—

*Power steering fluid, brake fluid, etc.

TIMING CHAIN

< REMOVAL AND INSTALLATION >

TIMING CHAIN

Exploded View

INFOID:000000011548507

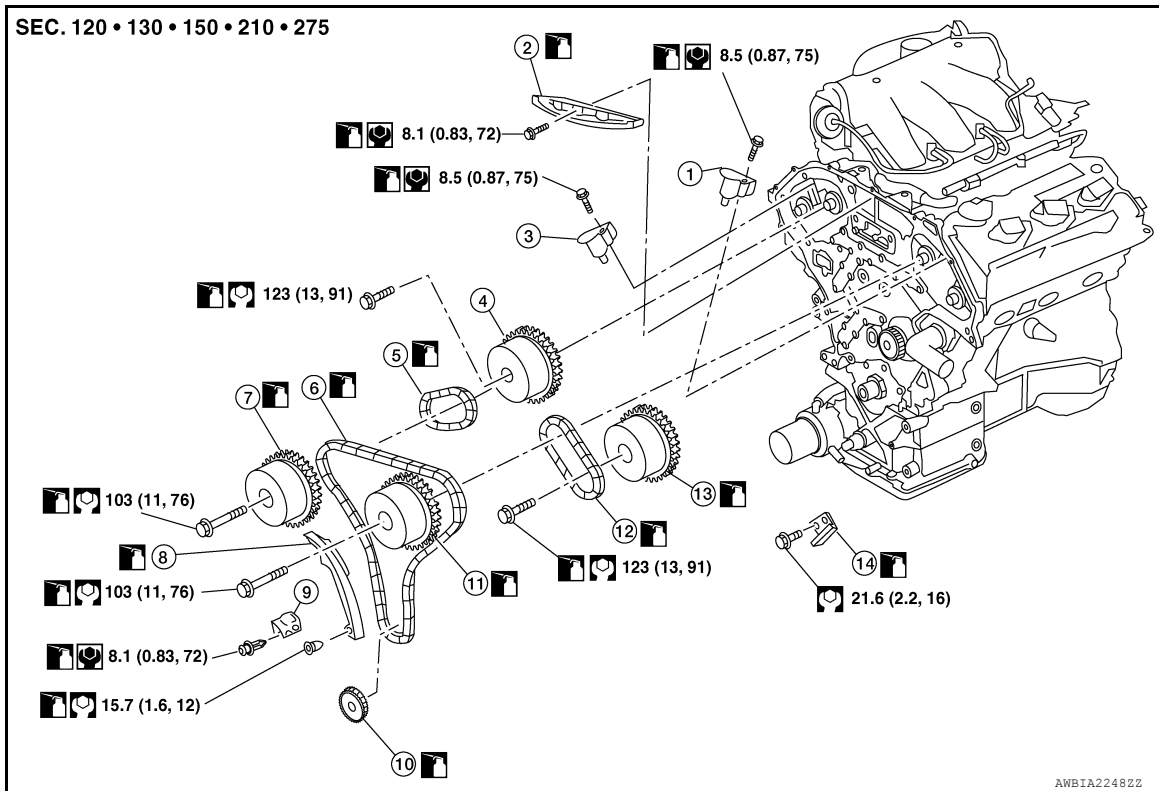

- | | | |
|--|--------------------------------|--|
| 1. Timing chain tensioner (secondary) (bank 2) | 2. Internal chain guide | 3. Timing chain tensioner (secondary) (bank 1) |
| 4. Camshaft sprocket (bank 1) (EXH) | 5. Timing chain (secondary) | 6. Timing chain (primary) |
| 7. Camshaft sprocket (bank 1) (INT) | 8. Slack guide | 9. Timing chain tensioner (primary) |
| 10. Crankshaft sprocket | 11. Camshaft sprocket (bank 2) | 12. Timing chain (secondary) (INT) |
| 13. Camshaft sprocket (bank 2) (EXH) | 14. Tension guide | |

Removal and Installation

INFOID:000000011548508

CAUTION:

- After removing timing chains, do not turn the crankshaft and camshaft separately or the valves will strike the pistons.
- When installing camshafts, chain tensioners, oil seals, or other sliding parts, lubricate contacting surfaces with new engine oil.
- Apply new engine oil to bolt threads and seat surfaces when installing camshaft sprockets, camshaft brackets, and crankshaft pulley.

REMOVAL

1. Remove front timing chain case. Refer to [EM-57, "Removal and Installation"](#).
2. Remove the intake manifold collector. Refer to [EM-28, "Removal and Installation"](#).
3. Remove the spark plugs. Refer to [EM-18, "Removal and Installation"](#).
4. Place paint marks on the timing chain and sprockets to indicate the correct position of the components for installation.
5. Disconnect the camshaft position sensor harness connectors.
6. Remove the timing chain tensioner (primary).

TIMING CHAIN

< REMOVAL AND INSTALLATION >

- a. Pull lever down and release plunger stopper tab. Plunger stopper tab can be pushed up to release (coaxial structure with lever).

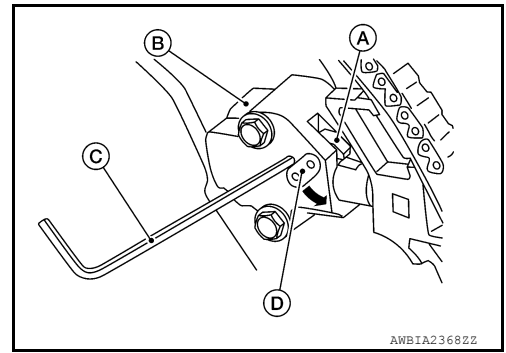

- b. Insert stopper pin (D) into timing chain tensioner (primary) body hole to hold lever, and keep the tab released. An allen wrench [1.2 mm (0.047 in)] is used for a stopper pin (D) as an example.
- c. Insert plunger (A) into tensioner body by pressing the slack guide (B).
- d. Keep the slack guide (B) pressed and hold it by pushing the stopper pin (D) through the lever hole and body hole.
- e. Remove the bolts and remove the timing chain tensioner (primary).

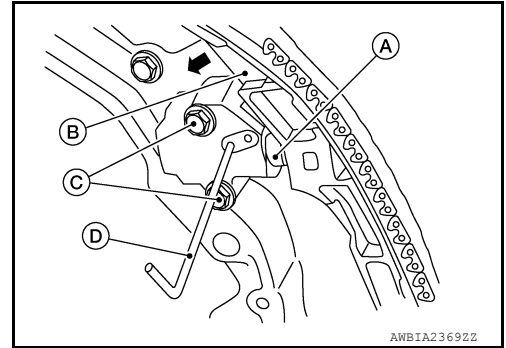

7. Remove internal chain guide (A), tension guide (C) and slack guide (B).

NOTE:

Tension guide (C) can be removed after removing timing chain (primary).

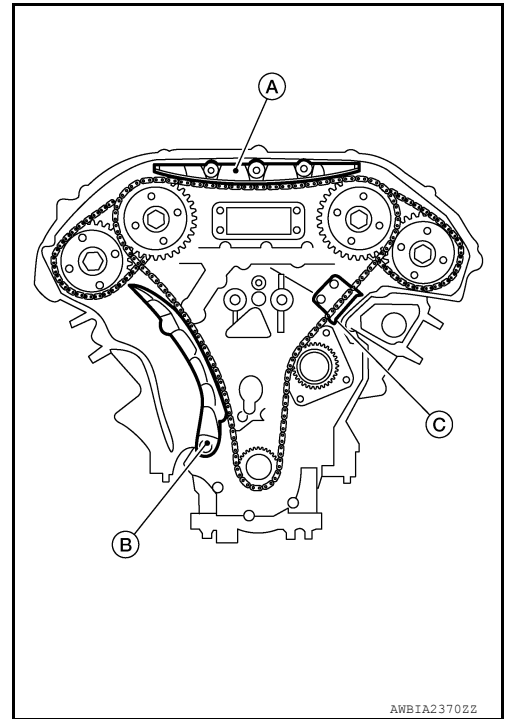

8. Remove timing chain (primary) and crankshaft sprocket.

CAUTION:

After removing timing chains, do not turn the crankshaft and camshaft separately or the valves will strike the pistons.

9. Remove timing chain (secondary) and camshaft sprockets as follows:

TIMING CHAIN

< REMOVAL AND INSTALLATION >

- a. Attach a suitable stopper pin (B) to the bank 1 [RH (A)] and bank 2 [LH (C)] timing chain tensioners (secondary) (1).

NOTE:

- Use approximately 0.5 mm (0.02 in) diameter hard metal pin as a stopper pin.
- Removal of camshaft bracket (No. 1) is required prior to removing the timing chain tensioner (secondary).

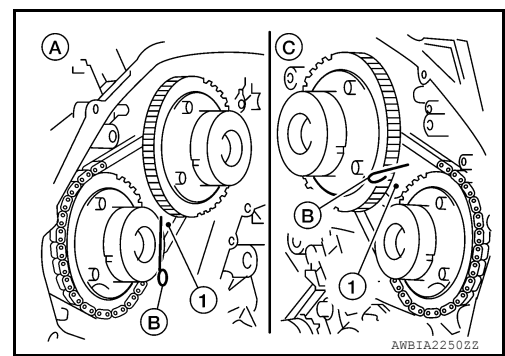

- b. Remove camshaft sprockets (INT/EXH) bolts.
- Secure the hexagonal portion of camshaft using a suitable tool to loosen bolts.

CAUTION:

Do not loosen bolts using anything other than the camshaft hexagonal portion. Do not apply tension to the timing chain.

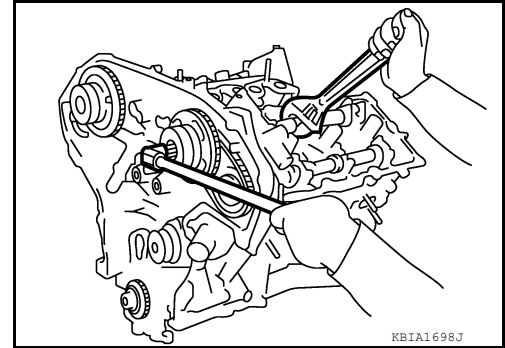

- c. Remove timing chain (secondary) together with camshaft sprockets.
- Turn camshaft slightly to keep the chain tight when removing the timing chain (secondary).
 - Insert 0.5 mm (0.020 in) thick metal or resin plate between timing chain and timing chain tensioner plunger (guide) (E). Remove timing chain (secondary) (2) together with camshaft sprockets with timing chain loose from guide groove.

- (1) : Timing chain tensioner (secondary)
- (A) : Bank 1 (RH)
- (B) : View B
- (C) : Stopper pin
- (D) : Plate
- (F) : Timing chain tensioner (body)

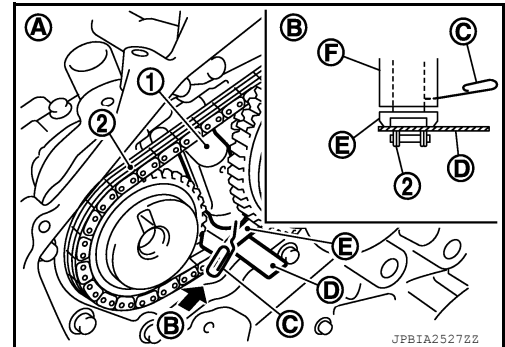

CAUTION:

Be careful of plunger coming off when removing timing chain (secondary). The plunger of timing chain tensioner (secondary) moves during operation, which could cause the stopper pin to fall out.

- Bank 1 shown.

- d. Camshaft sprocket (INT) is two-for-one structure of sprockets for timing chain (primary) and for timing chain (secondary).

CAUTION:

- Handle camshaft sprocket (INT) carefully to avoid any shock to camshaft sprocket.
- Do not disassemble. [Do not loosen bolts (A) as shown].

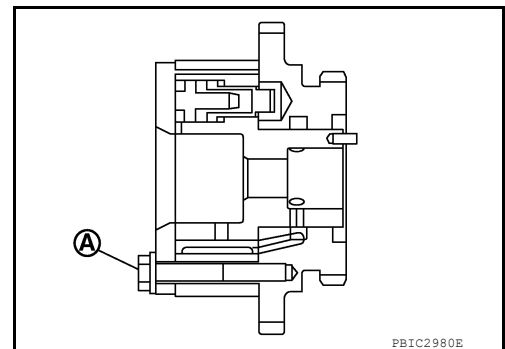

INSPECTION

TIMING CHAIN

< REMOVAL AND INSTALLATION >

Check for cracks and any excessive wear of the timing chain. Replace the timing chain as necessary.

INSTALLATION

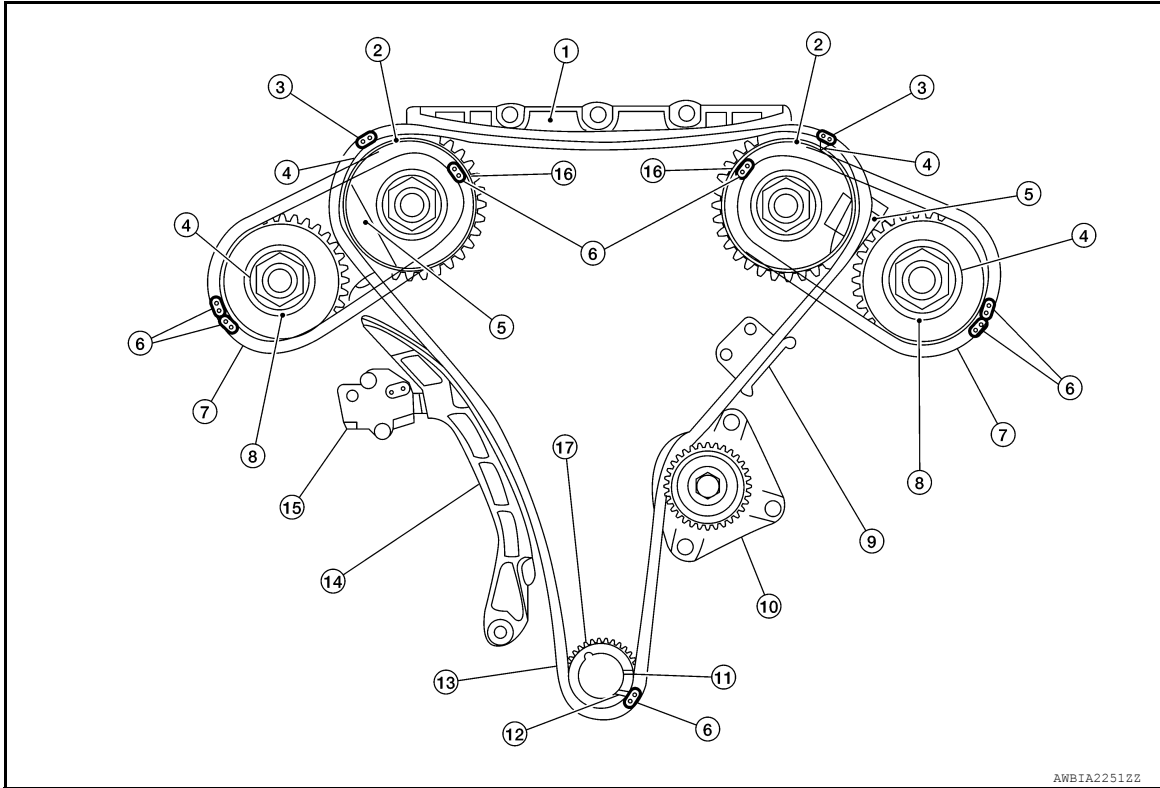

- | | | |
|-----------------------------|---------------------------------------|--------------------------------------|
| 1. Internal chain guide | 2. Camshaft sprocket (INT) | 3. Mating mark (pink link) |
| 4. Mating mark (punched) | 5. Timing chain tensioner (secondary) | 6. Mating mark (orange link) |
| 7. Timing chain (secondary) | 8. Camshaft sprocket (EXH) | 9. Tension guide |
| 10. Water pump | 11. Crankshaft sprocket | 12. Mating mark (notched) |
| 13. Timing chain (primary) | 14. Slack guide | 15. Timing chain tensioner (primary) |
| 16. Mating mark (back side) | 17. Crankshaft key | |

NOTE:

This illustration shows the relationship between the mating mark on each timing chain and on the corresponding sprocket with the components installed.

1. Install timing chain tensioners (secondary) with a new O-ring and the stopper pin attached.

CAUTION:

Do not reuse O-ring.

2. Check that dowel pin (A) and crankshaft key (1) are located as shown. (No. 1 cylinder at compression TDC)

NOTE:

Though camshaft does not stop at the position as shown, for the placement of cam nose, it is generally accepted camshaft is placed in the same direction.

Camshaft dowel pin

: At cylinder head upper face side in each bank

Crankshaft key

: At cylinder head side of bank 1

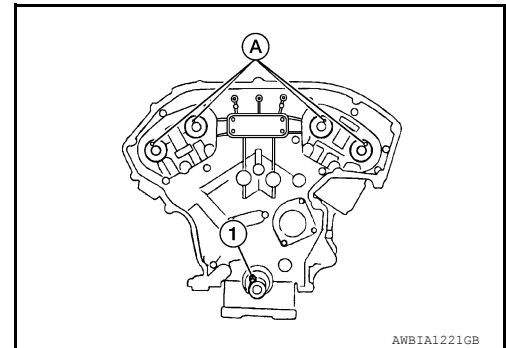

3. Install timing chain (secondary) and camshaft sprockets (INT and EXH) as follows:

CAUTION:

Mating marks between timing chain and sprockets slip easily. Confirm all mating mark positions repeatedly during the installation process.

TIMING CHAIN

< REMOVAL AND INSTALLATION >

- a. Push plunger of timing chain tensioner (secondary) and keep it pressed in with stopper pin (A).

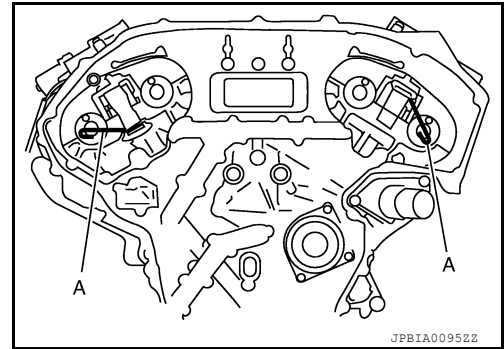

- b. Install timing chain (secondary) (2) and camshaft sprockets [INT (1) and EXH (3)].

- (A) : Dowel pin groove
- (B) : Mating mark (2 oblong on rear face)
- (C) : Orange link
- (D) : Mating mark (2 circles on rear face)
- (E) : Mating mark (Oblong on rear face)
- (F) : Dowel pin groove
- (G) : Mating mark (Circle on rear face)
- (H) : Orange link

NOTE:

Bank 1 shown (rear view).

- Align the mating marks on timing chain (secondary) (orange link) with the mating marks on camshaft sprockets (INT and EXH), and install them.
- Align dowel pin on camshafts with the groove on sprockets, and install them.
- Tighten the bolts for the camshaft sprockets by hand, enough to prevent the dowel pins from falling out of the grooves.

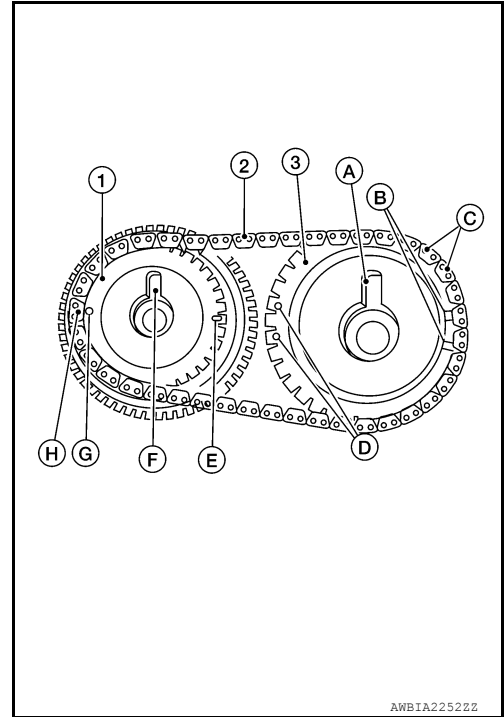

- It may be difficult to visually check the dislocation of mating marks during and after installation. To make the matching easier, make a mating mark (A) on the top of sprocket teeth and its extended line with paint.

- (B) : Mating mark (orange link)

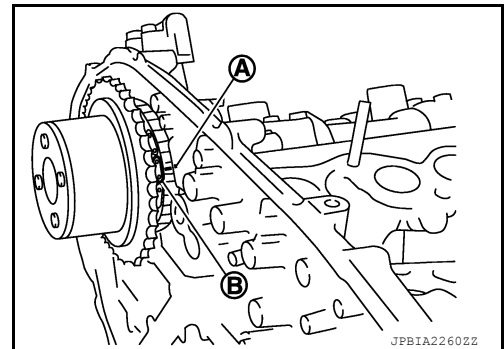

4. After confirming the mating marks are aligned, tighten the camshaft sprocket bolts.
- Secure the camshaft using a wrench at the hexagonal portion to tighten the bolts.

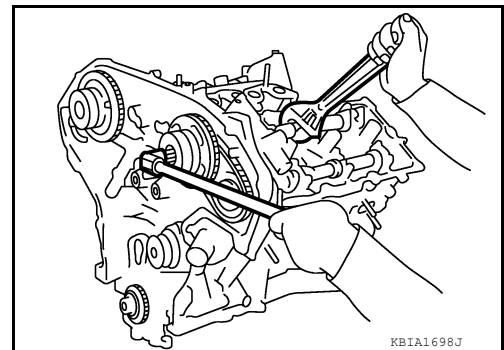

A
EM
C
D
E
F
G
H
I
J
K
L
M
N
O
P

TIMING CHAIN

< REMOVAL AND INSTALLATION >

5. Pull stopper pins (B) out from timing chain tensioners (secondary) (1).

- (A) : Bank 1 (RH)
(C) : Bank 2 (LH)

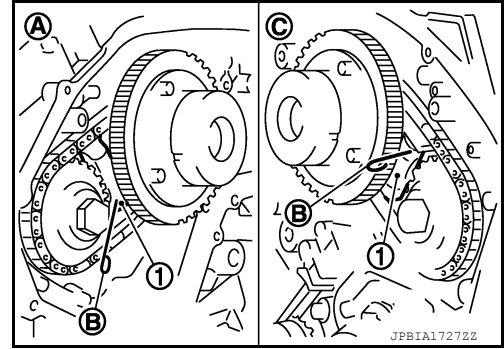

6. Install the crankshaft sprocket (C) on the crankshaft.
- Make sure the mating marks (D) on the crankshaft sprocket (C) face the front of the engine.
 - The flat side of the crankshaft sprocket (C) is on the crankshaft side (A)

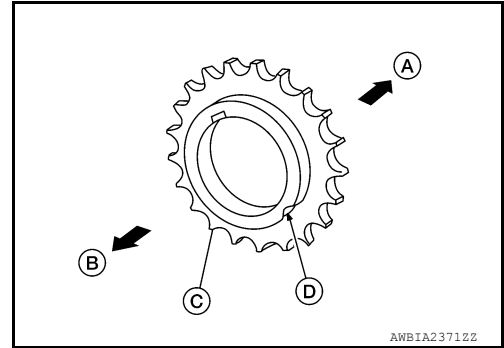

7. Install the timing chain (primary).
- Install timing chain (primary) so the mating mark (punched) (B) on camshaft sprocket (C) is aligned with the pink link (A) on the timing chain, while the mating mark (notched) (E) on the crankshaft sprocket (D) is aligned with the orange one (F) on the timing chain, as shown.
 - When it is difficult to align mating marks of the timing chain (primary) with each sprocket, gradually turn the camshaft using a wrench on the hexagonal portion to align it with the mating marks.
 - During alignment, be careful to prevent dislocation of mating mark alignments of the secondary timing chains.

- (G) : Water pump

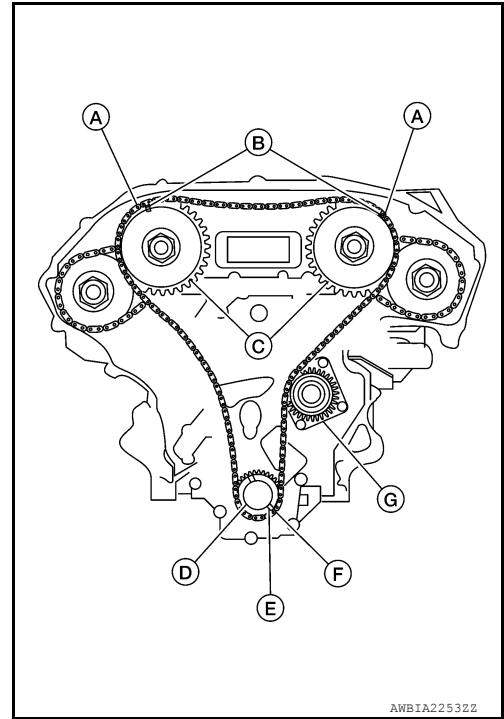

TIMING CHAIN

< REMOVAL AND INSTALLATION >

8. Install the internal chain guide (1) and slack guide (2).

(3) : Tension guide

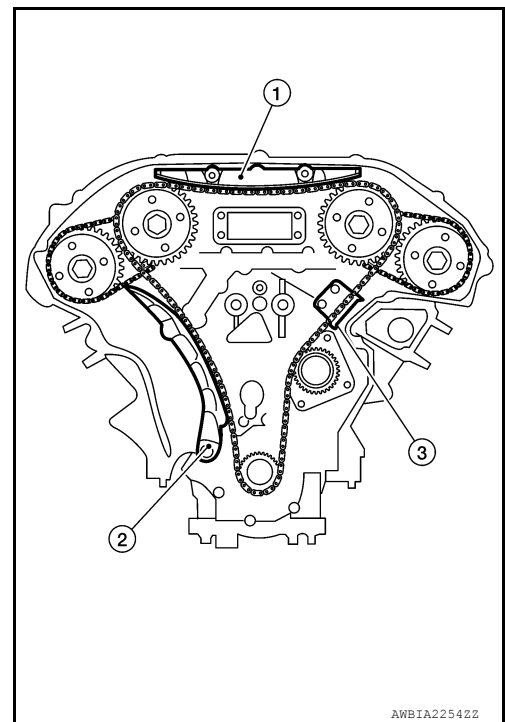

CAUTION:

Do not over tighten slack guide mounting bolt (2). It is normal for a gap (A) to exist under the bolt seat when bolt is tightened to specification.

(1) : Slack guide

(3) : Cylinder block

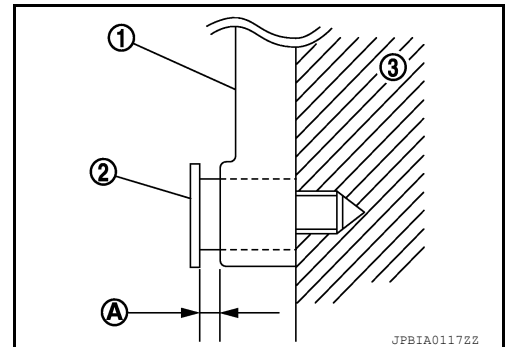

9. Install the timing chain tensioner (primary) with the following procedure:

a. Pull plunger stopper tab (A) up (or turn lever downward) so as to remove plunger stopper tab from the ratchet of plunger (D).

NOTE:

Plunger stopper tab and lever (C) are synchronized.

b. Push plunger into the inside of tensioner body.

c. Hold plunger in the fully compressed position by engaging plunger stopper tab with the tip of ratchet.

d. To secure lever, insert stopper pin (E) through hole of lever into tensioner body hole (B).

• The lever parts and the tab are synchronized. Therefore, the plunger will be secured under this condition.

NOTE:

Illustration shows the example of 1.2 mm (0.047 in) diameter thin screwdriver being used as the stopper pin.

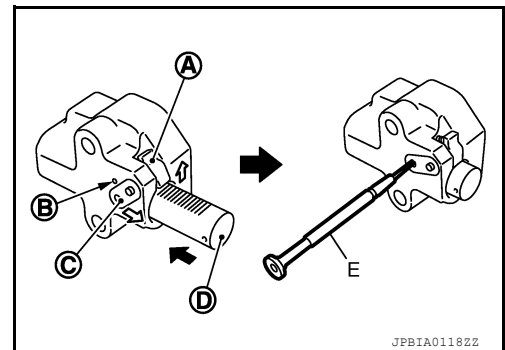

TIMING CHAIN

< REMOVAL AND INSTALLATION >

- e. Install timing chain tensioner (primary) (1).
 - Remove any dirt and foreign materials completely from the back and the mounting surfaces of timing chain tensioner (primary).
- f. Pull out stopper pin (A) after installing, and then release plunger.

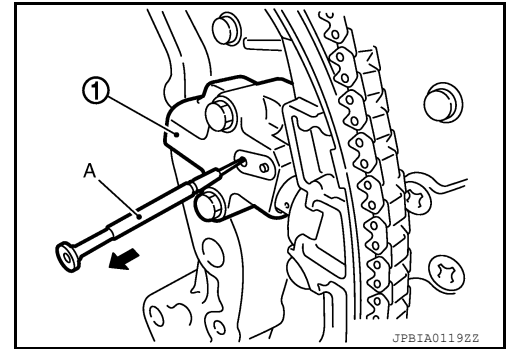

10. Reconfirm that the matching marks on the sprockets and the timing chain have not slipped out of alignment.
11. Install the spark plugs. Refer to [EM-18, "Removal and Installation"](#).
12. Install the intake manifold collector. Refer to [EM-28, "Removal and Installation"](#).
13. Install the front timing chain case. Refer to [EM-57, "Removal and Installation"](#).

REAR TIMING CHAIN CASE

< REMOVAL AND INSTALLATION >

REAR TIMING CHAIN CASE

Exploded View

INFOID:000000011220666

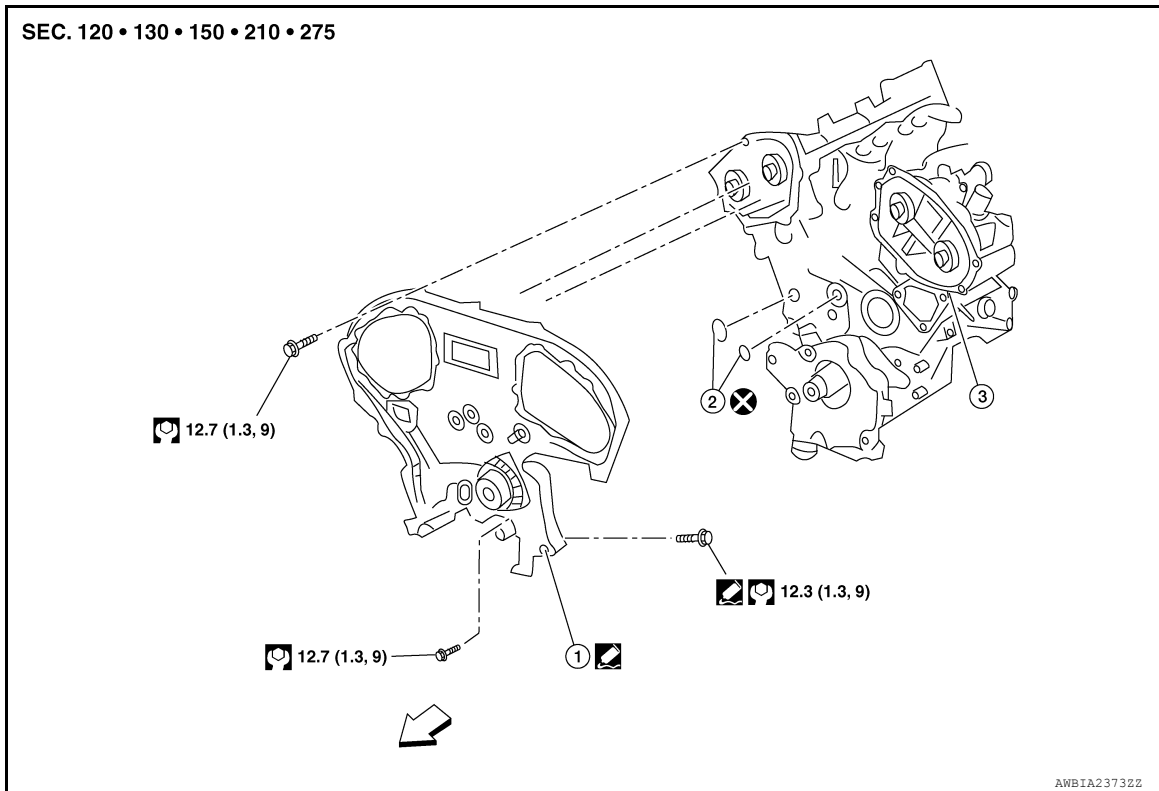

1. Rear timing chain case

2. O-ring

3. Cylinder block

Removal and Installation

INFOID:000000011220667

CAUTION:

- After removing timing chain, do not turn the crankshaft and camshaft separately, or the valves will strike the pistons.
- Before removing the upper oil pan, remove the crankshaft position sensor (POS).
- Be careful not to damage sensor edges.

REMOVAL

1. Remove the engine assembly. Refer to [EM-104, "FWD : Removal and Installation"](#) (FWD) or [EM-109, "AWD : Removal and Installation"](#) (AWD).
2. Remove upper oil pan. Refer to [EM-39, "Removal and Installation \(Upper Oil Pan\)"](#).
3. Remove the front timing chain case. Refer to [EM-57, "Removal and Installation"](#).
4. Remove the timing chains (primary) and (secondary). Refer to [EM-65, "Removal and Installation"](#).
5. Remove the rear timing chain case.

CAUTION:

- Do not remove the plate metal cover for the oil passage.
- After removing the chain case, do not apply any load to the case that might bend it.

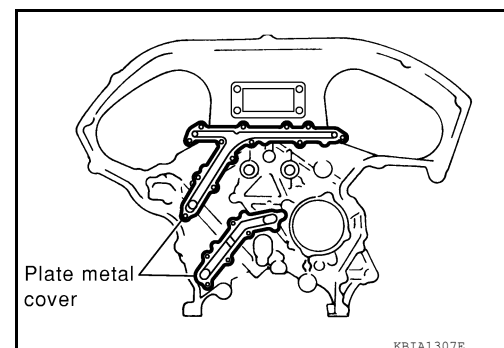

REAR TIMING CHAIN CASE

< REMOVAL AND INSTALLATION >

- a. Loosen and remove the rear timing chain case bolts in the reverse order shown.

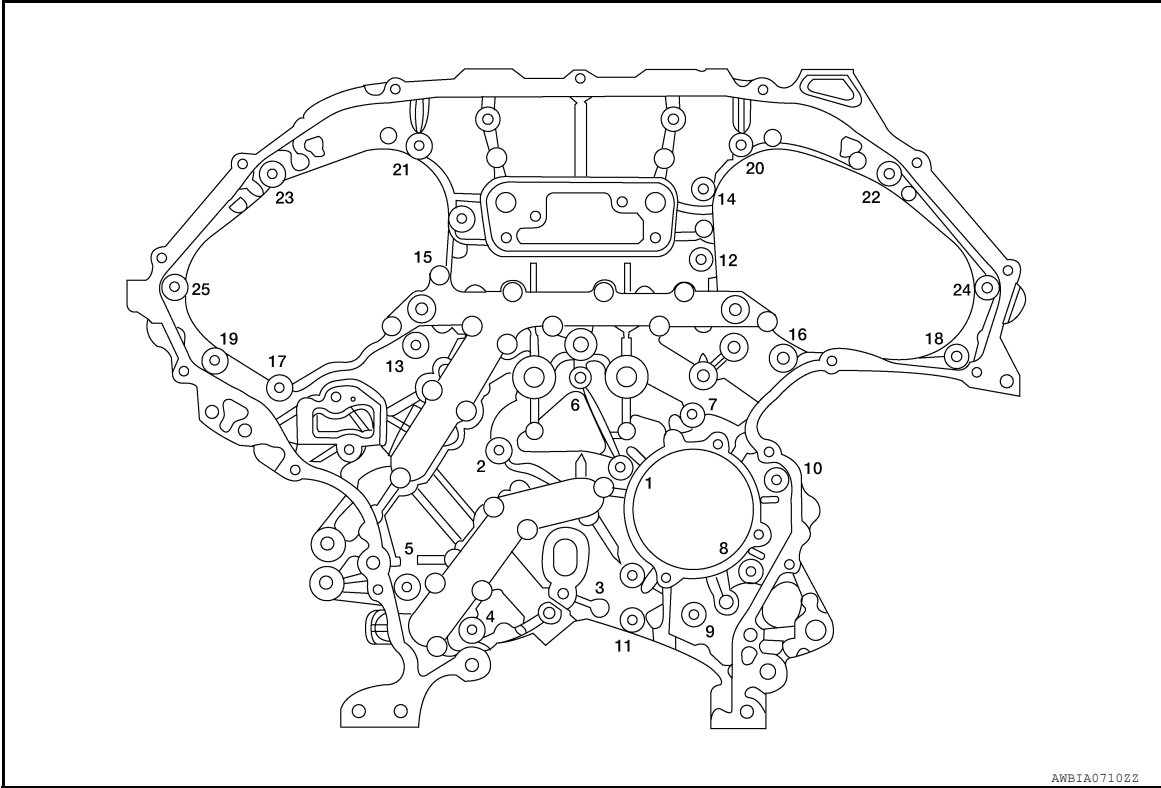

- b. Cut the sealant using Tool and remove the rear timing chain case.
• After removing the bolts, separate the mating surface and remove the old liquid gasket using Tool.

Tool number : KV10111100 (J-37228)

CAUTION:

Do not damage the mating surfaces.

- Tap the seal cutter to insert it (1).
- In areas where the Tool is difficult to use, lightly tap to slide it (2).

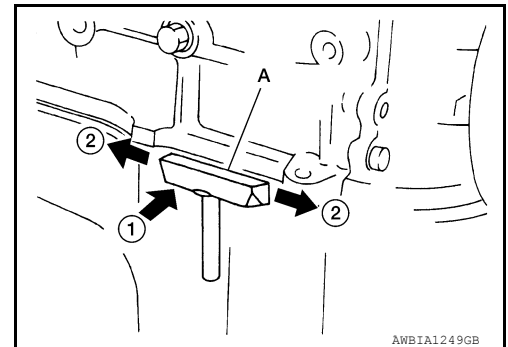

6. Remove O-rings (1) from cylinder block.

⇐ : Engine front

CAUTION:

Do not reuse O-rings.

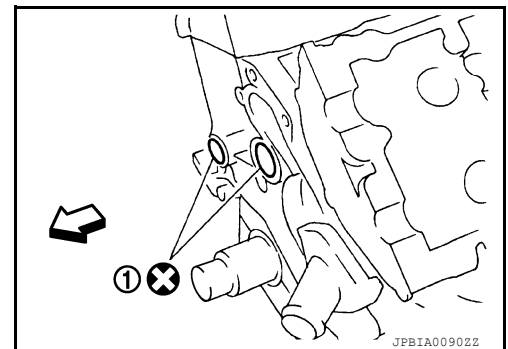

REAR TIMING CHAIN CASE

< REMOVAL AND INSTALLATION >

7. Use a scraper to remove all of the old Silicone RTV Sealant from the front and rear timing chain case and opposite mating surfaces.

CAUTION:

Do not damage the mating surfaces.

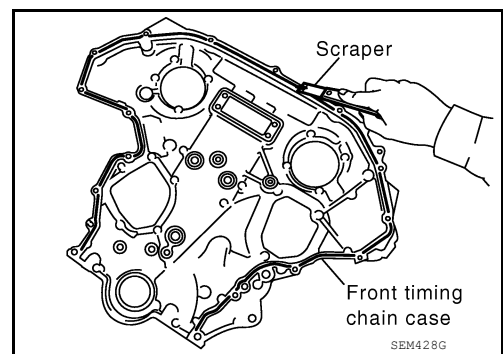

8. Remove all old Silicone RTV Sealant from all the bolt holes and bolts.

CAUTION:

Do not damage the threads or mating surfaces.

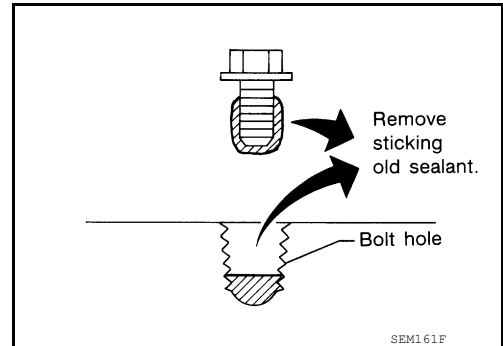

INSTALLATION

1. Install O-rings (1) on cylinder block.

⇐ : Engine front

CAUTION:

Do not reuse O-rings.

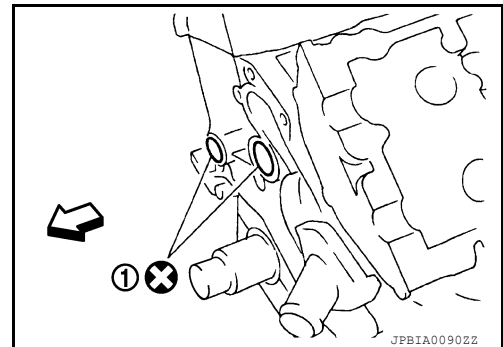

2. Apply Genuine Silicone RTV Sealant or equivalent, to the rear timing chain case using suitable tool as shown. Refer to [GI-22. "Recommended Chemical Products and Sealants"](#).

CAUTION:

- Installation should be done within 5 minutes after applying liquid gasket.
- Do not fill the engine with engine oil for at least 30 minutes after the components are installed to allow the sealant to cure.
- Wipe off liquid gasket where it touches the engine coolant passage at point (A).
- Follow the installation instructions for applying the liquid gasket. Pay particular attention to the water pump and cylinder area.

REAR TIMING CHAIN CASE

< REMOVAL AND INSTALLATION >

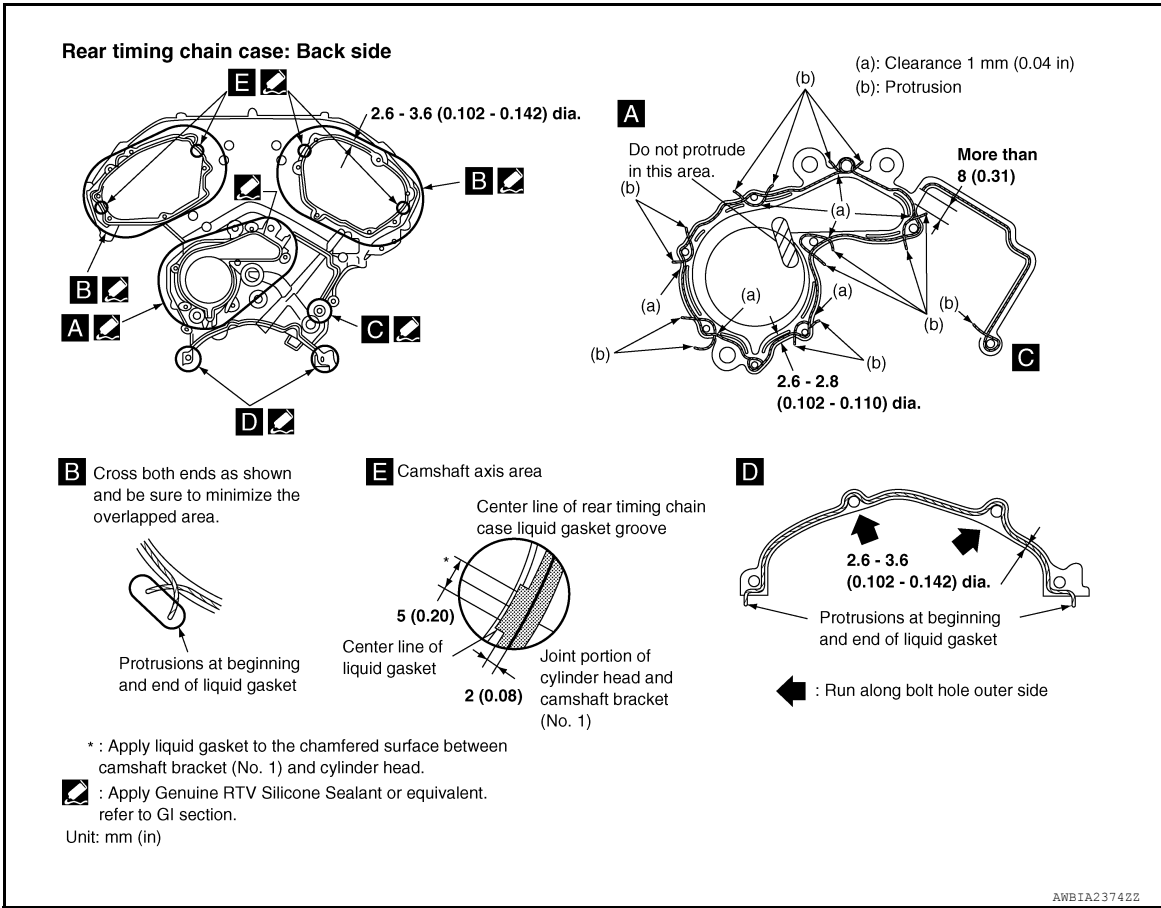

3. Align the rear timing chain case and water pump assembly with the dowel pins (RH and LH) on the cylinder block and install the case. Make sure the O-rings stay in place during installation.
 - a. Tighten the bolts in the numerical order as shown. There are two bolt lengths used. Follow the chart below for proper bolt length specifications.

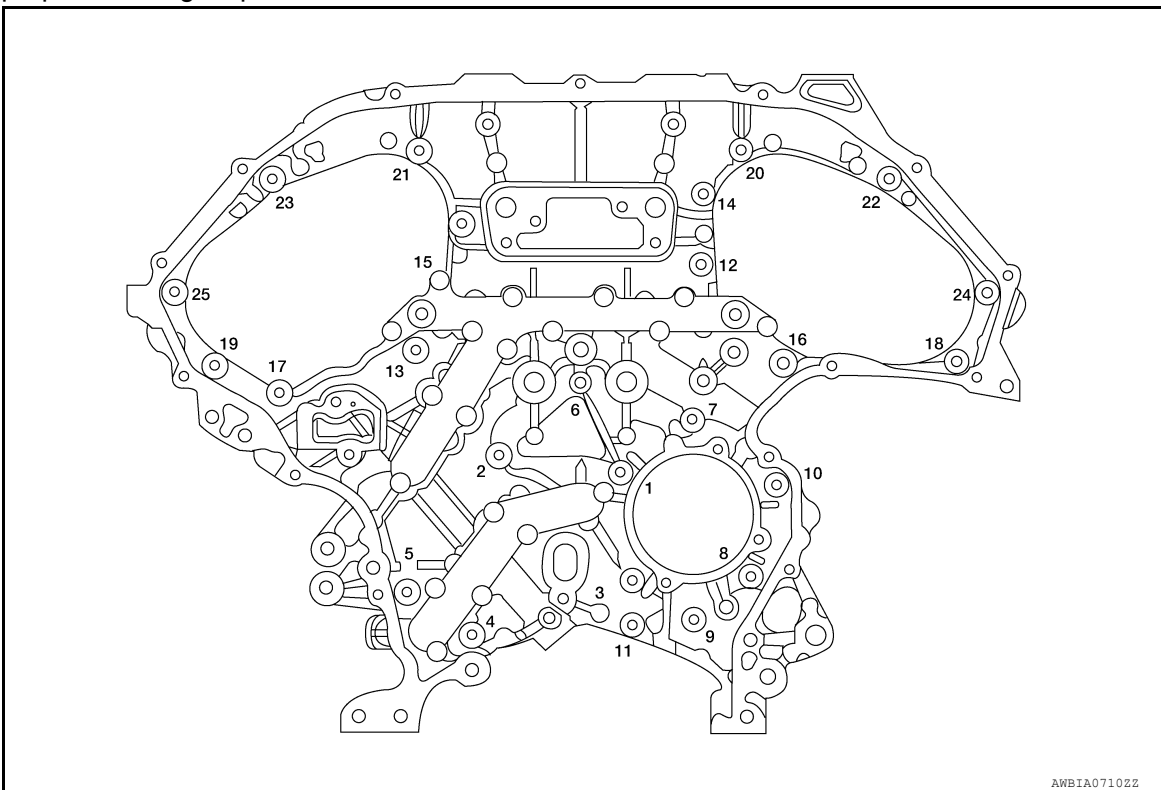

REAR TIMING CHAIN CASE

< REMOVAL AND INSTALLATION >

Bolt length	Bolt position	Torque specification
20 mm (0.79 in)	1, 2, 3, 6, 7, 8, 9, 10	12.7 N·m (1.3 kg-m, 9 ft-lb)
16 mm (0.63 in)	All except the above	12.7 N·m (1.3 kg-m, 9 ft-lb)

- b. After all bolts are initially tightened, retighten them to the specification in the numerical order as shown.

NOTE:

If liquid gasket protrudes, wipe it off immediately.

4. Install the timing chains (primary and secondary). Refer to [EM-65, "Removal and Installation"](#).
5. Install the front timing chain case. Refer to [EM-57, "Removal and Installation"](#).
6. Install the upper oil pan. Refer to [EM-39, "Removal and Installation \(Upper Oil Pan\)"](#).
7. Install the engine assembly. Refer to [EM-104, "FWD : Removal and Installation"](#) (FWD) or [EM-109, "AWD : Removal and Installation"](#) (AWD).

A

EM

C

D

E

F

G

H

I

J

K

L

M

N

O

P

CAMSHAFT

< REMOVAL AND INSTALLATION >

CAMSHAFT

Exploded View

INFOID:000000011552718

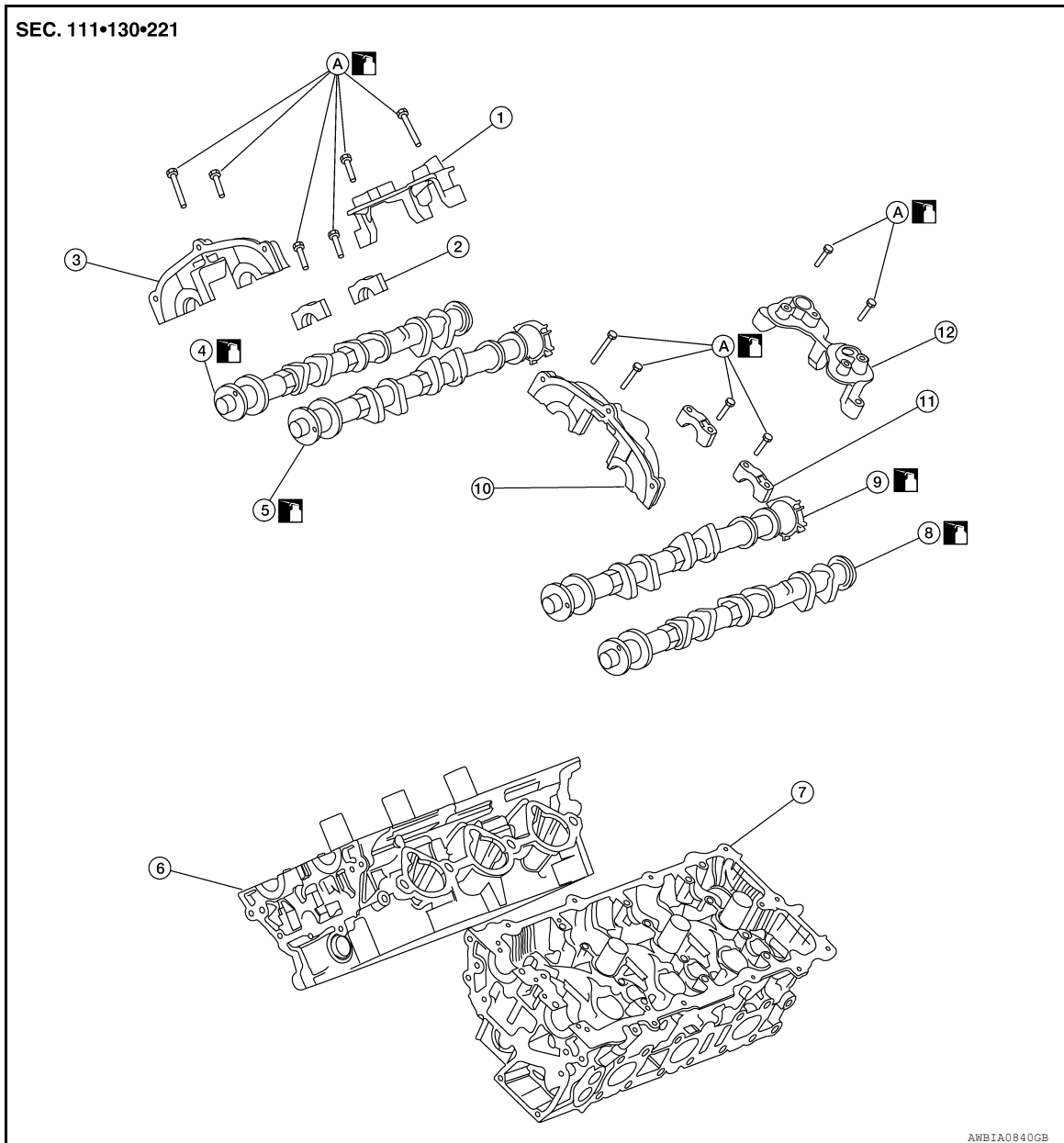

- | | | |
|--|----------------------------|---|
| 1. Camshaft position sensor bracket (bank 1) | 2. Camshaft brackets | 3. No. 1 camshaft bracket (bank 1) |
| 4. Camshaft (EXH) (bank 1) | 5. Camshaft (INT) (bank 1) | 6. Cylinder head (bank 1) |
| 7. Cylinder head (bank 2) | 8. Camshaft (EXH) (bank 2) | 9. Camshaft (INT) (bank 2) |
| 10. No. 1 camshaft bracket (bank 2) | 11. Camshaft brackets | 12. Camshaft position sensor bracket (bank 2) |

A. Refer to INSTALLATION

Removal and Installation

INFOID:000000011552719

CAUTION:

Apply new engine oil to parts marked in illustration before installation.

CAMSHAFT

< REMOVAL AND INSTALLATION >

REMOVAL

1. Remove the timing chains. Refer to [EM-65. "Removal and Installation"](#).
2. Remove camshaft position sensor brackets (RH shown LH similar).

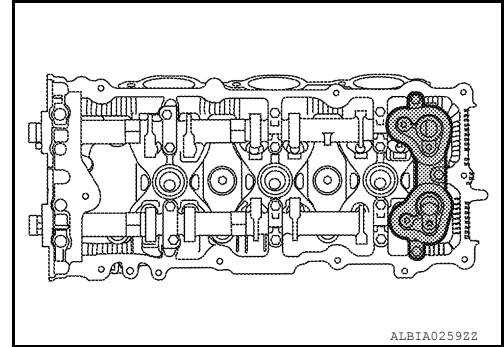

3. Remove the intake and exhaust camshaft brackets (bank 1) (C) and the camshafts (bank 1) (A/B).
 - Mark the camshafts (bank 1) (A/B), camshaft brackets (bank 1) (C), and bolts so they are placed in the same position and direction for installation.
 - Equally loosen the camshaft bracket bolts in several steps in the numerical order as shown.

← :Engine front

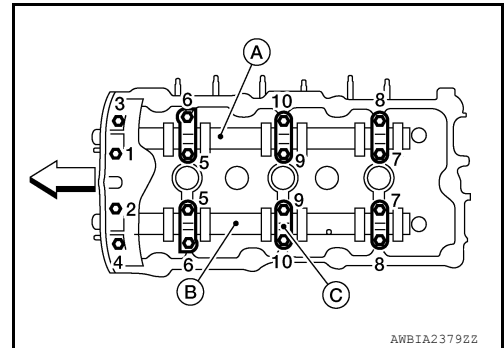

4. Remove the intake and exhaust camshaft brackets (bank 2) (B) and the camshafts (bank 2) (A/C).
 - Mark the camshafts (bank 2) (A/C), camshaft brackets (bank 2) (B), and bolts so they are placed in the same position and direction for installation.
 - Equally loosen the camshaft bracket bolts in several steps in the numerical order as shown.

← :Engine front

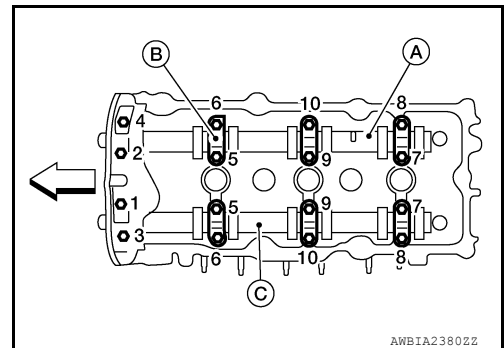

5. Remove valve lifters, if necessary.

NOTE:

Identify installation positions to ensure proper installation.

6. Remove secondary timing chain tensioner (2/5) from bank 1/ bank 2 (A/B)

- Remove secondary tensioner (2/5) with its stopper pin (4) attached.

NOTE:

- Stopper pin (4) was attached when secondary timing chain (2/5) was removed.
- Do not reuse O-rings (1/3).

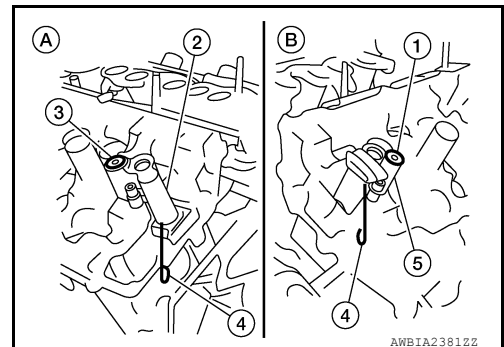

INSTALLATION

CAMSHAFT

< REMOVAL AND INSTALLATION >

1. Before installation, remove any old Silicone RTV Sealant (A) from component mating surfaces using a suitable tool.
 - Remove the old Silicone RTV Sealant (A) from the bolt holes (B) and threads.
 - Do not scratch or damage the mating surfaces.

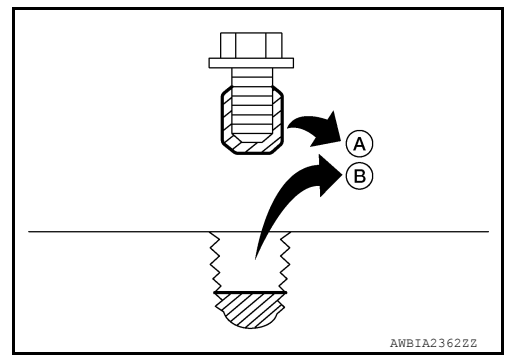

2. Before installing the front cam bracket, remove the old Silicone RTV Sealant (B) from the mating surface using a suitable tool (A).
 - Do not scratch or damage the mating surface.

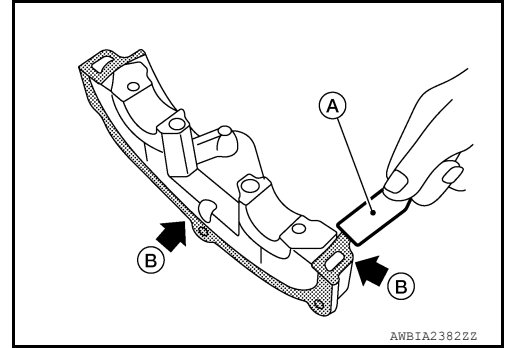

3. Turn the crankshaft until No. 1 piston is set at TDC on the compression stroke.
 - The crankshaft key (A) should line up with the right bank cylinder center line (B) as shown.

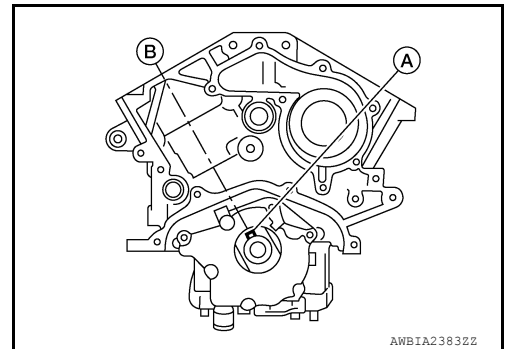

4. Install camshaft chain tensioners (1/2) at bank 1 (A) and bank 2 (B). Refer to [EM-65. "Exploded View"](#).

CAUTION:

Do not reuse O-rings.

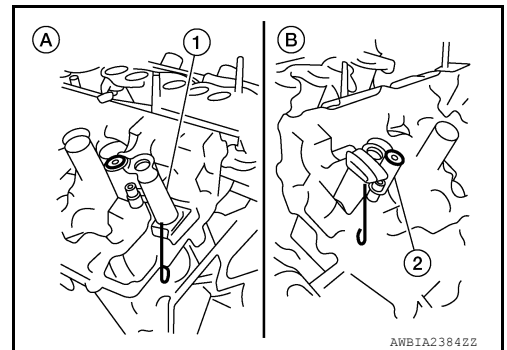

5. Install valve lifters, if removed.
NOTE:
Install them in original positions.

CAMSHAFT

< REMOVAL AND INSTALLATION >

6. Install exhaust camshaft (A) and intake camshaft (B) and camshaft brackets.
 - Intake camshaft has a drill mark (C) on camshaft sprocket mounting flange.

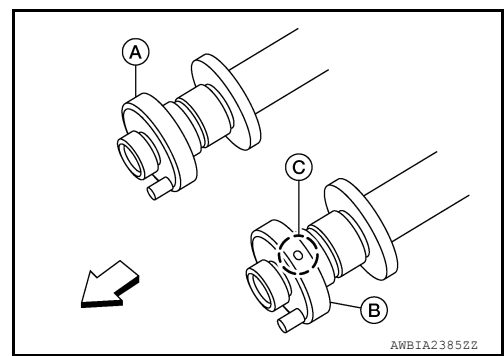

A

EM

C

D

- Follow your identification marks made during removal, or follow the identification marks that are present on the new camshafts components for proper placement and direction of the components.

← : Engine front

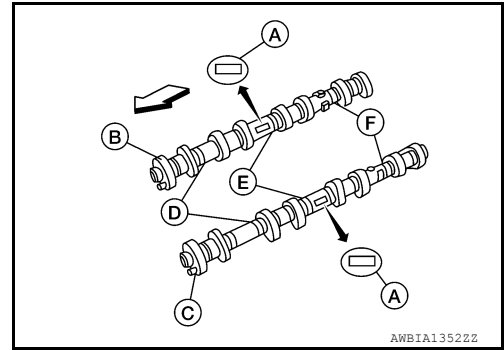

E

F

G

H

Bank	INT/EXH	ID mark (A)	Drill mark	Paint marks		
				M1 (E)	M2 (F)	M3 (D)
1 (B)	INT	1A	Yes	Purple	No	Light blue
	EXH	1C	No	No	Brown	Light blue
2 (C)	INT	1B	Yes	Purple	No	Light blue
	EXH	1D	No	No	Brown	Light blue

- Position the camshaft dowel pins (A) as shown.

(1) : Crankshaft key

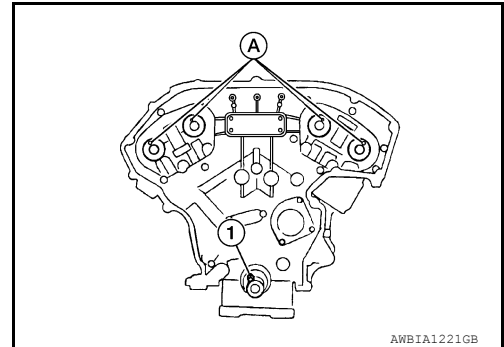

I

J

K

L

M

N

O

P

CAMSHAFT

< REMOVAL AND INSTALLATION >

7. Apply sealant to mating surface of camshaft brackets (1) of bank 1 (A) and bank 2 (B) cylinder heads.
 - Use **Genuine Silicone RTV Sealant, or equivalent. Refer to [GI-22, "Recommended Chemical Products and Sealants"](#).**
 - Before installation, wipe off any protruding sealant from front face of camshaft bracket.
 - Refer to [EM-5, "Precaution for Liquid Gasket"](#).

← :Engine front

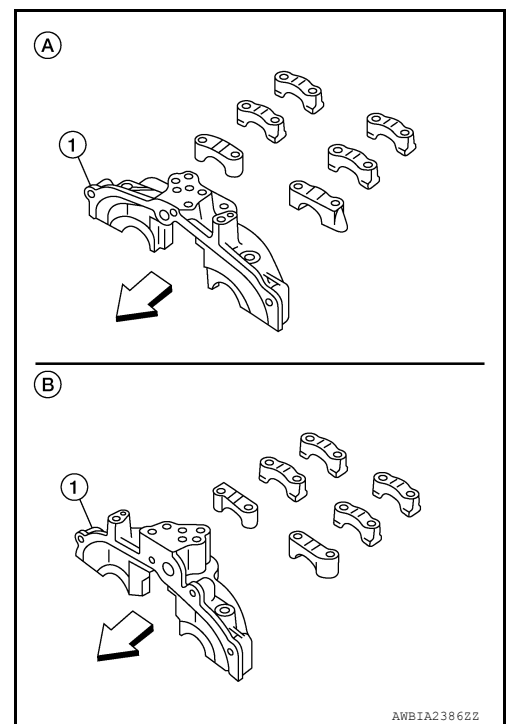

- Install bank 1 (B) and bank 2 (C) camshaft brackets in their original positions and direction. Align the stamp marks (A) as shown.
- If checking and adjusting any part of valve assembly or camshaft, check valve clearance according to the reference data. Refer to [EM-20, "Valve Clearance"](#).

← :Engine front

Valve clearance (cold) Intake : 0.26 - 0.34 mm (0.010 - 0.013 in)

Valve clearance (cold) Exhaust : 0.29 - 0.37 mm (0.011 - 0.015 in)

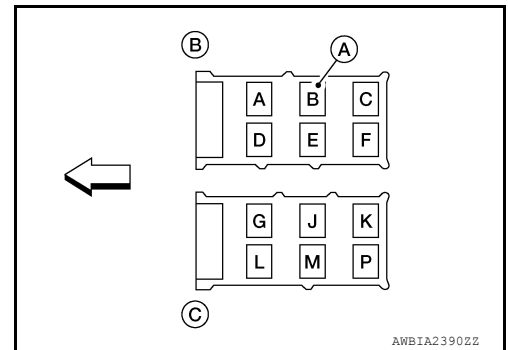

- Locate the camshaft (EXH) (bank 1) (A) and camshaft (INT) (bank 1) (B). Tighten the camshaft brackets (C) in the three steps, in numerical order as shown.

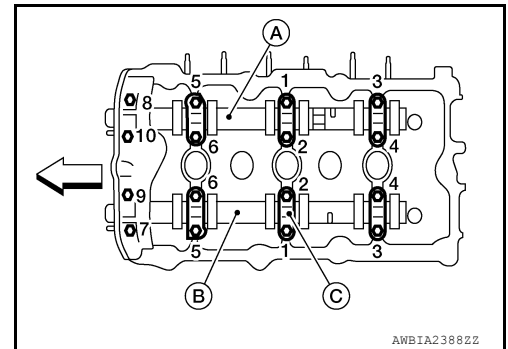

CAMSHAFT

< REMOVAL AND INSTALLATION >

- Locate the camshaft (EXH) (bank 2) (B) and camshaft (INT) (bank 2) (A). Tighten the camshaft brackets (C) in the three steps, in numerical order as shown.

1	1.96 N·m (0.20 kg·m, 17 in·lb)	Tighten No. 7 - 10, then tighten 1 - 6 in numerical order as shown.
2	5.88 N·m (0.60 kg·m, 52 in·lb)	Tighten all in numerical order as shown.
3	10.41 N·m (1.1 kg·m, 8 ft·lb)	Tighten No. 1 - 10 in numerical order as shown.

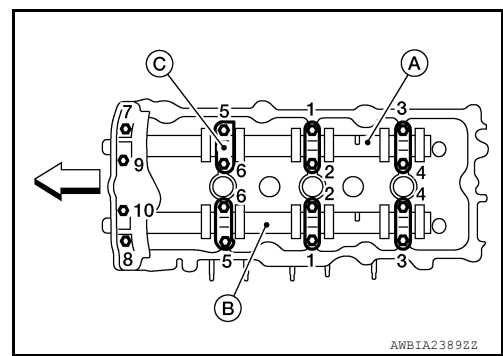

8. Measure difference in levels between front end faces of No. 1 camshaft bracket and cylinder head.

Standard : - 0.14 (- 0.0055 in)

- If measurement is outside the specified range, reinstall camshaft and camshaft bracket.

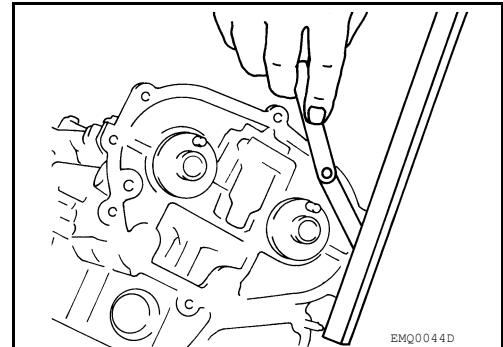

9. Install camshaft position sensor bracket (PHASE) (RH and LH bank.)
10. Install the timing chains. Refer to [EM-65. "Exploded View"](#).

INSPECTION AFTER REMOVAL

Camshaft Visual Check

Check camshaft for scratches, seizure and wear. Replace if necessary.

Camshaft Runout

1. Put V-block on precise flat bed and support No. 2 and No. 4 journal of camshaft as shown.
2. Set dial gauges vertically to No. 3 journal as shown.
3. Turn camshaft in one direction slowly by hand, measure the camshaft runout on the dial gauges.
 - Runout is the largest indicator reading after one full revolution. Refer to [EM-137. "Camshaft"](#).
4. If actual runout exceeds the limit, replace the camshaft.

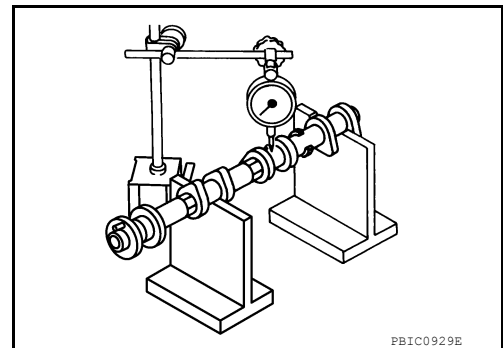

Camshaft Cam Lobe Height

1. Measure camshaft cam lobe height as shown. Refer to [EM-137. "Camshaft"](#).
2. If wear has reduced the lobe height below specifications, replace the camshaft.

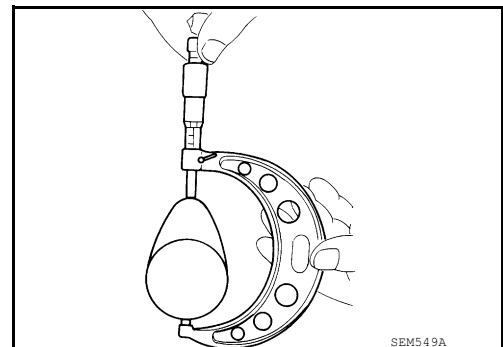

CAMSHAFT

< REMOVAL AND INSTALLATION >

Camshaft Journal Clearance

Outer Diameter of Camshaft Journal

- Measure outer diameter of camshaft journal as shown. Refer to [EM-137. "Camshaft"](#).

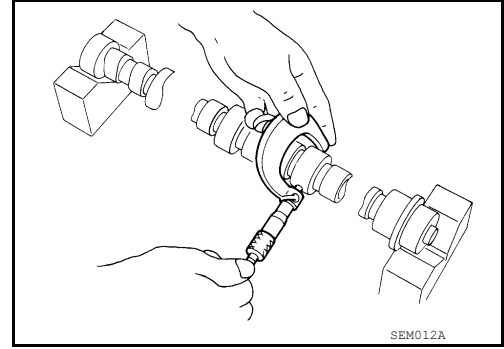

Inner Diameter of Camshaft Bracket

1. Tighten camshaft bracket bolt with specified torque.
2. Using inside micrometer, measure inner diameter (A) of camshaft bearing. Refer to [EM-137. "Camshaft"](#).

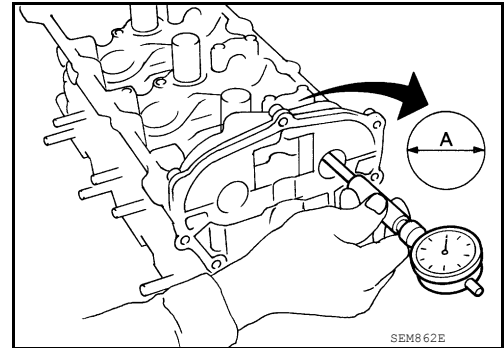

Calculation of Camshaft Journal Clearance

(Journal clearance) = (inner diameter of camshaft bracket) – (outer diameter of camshaft journal). Refer to [EM-137. "Camshaft"](#).

- When out of the specified range, replace either or both camshaft and cylinder head.

NOTICE:

Inner diameter of camshaft bracket is manufactured together with cylinder head. Replace the whole cylinder head assembly.

Camshaft End Play

1. Install the camshaft in the cylinder head.
 2. Install dial gauge in thrust direction on front end of camshaft. Measure end play when camshaft is moved forward/backward (in direction to axis) as shown. Refer to [EM-137. "Camshaft"](#).
- If out of the specified range, replace with new camshaft and measure again.
 - If out of the specified range again, replace with new cylinder head.

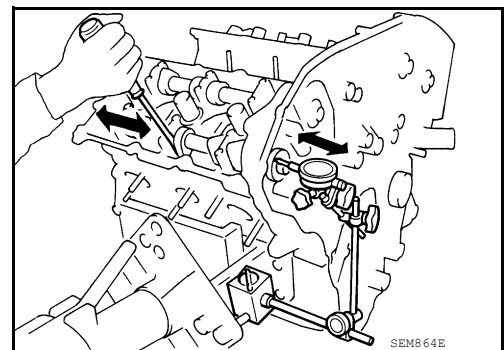

Camshaft Sprocket Runout

CAMSHAFT

< REMOVAL AND INSTALLATION >

1. Put V-block on precise flat bed and support No. 2 and No. 4 journal of camshaft as shown.
2. Install camshaft sprocket on camshaft.
3. Measure camshaft sprocket runout. Refer to [EM-137. "Camshaft"](#).
4. If sprocket runout exceeds the limit, replace camshaft sprocket.

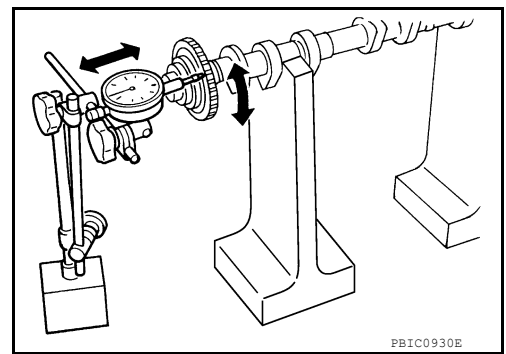

Valve Lifter

- Check if the surface of the valve lifter has any excessive wear or cracks, replace as necessary.

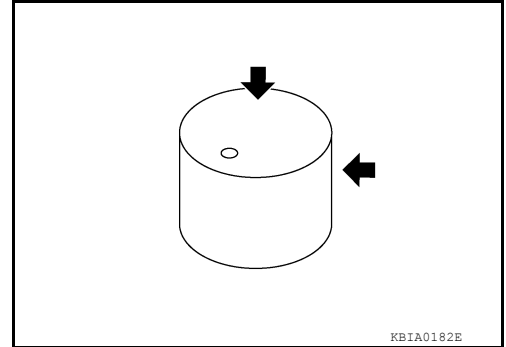

Valve Lifter Clearance

Outer Diameter of Valve Lifter

- Measure the outer diameter of the valve lifter with a suitable tool (A). Refer to [EM-137. "Camshaft"](#).
- If out of the specified range, replace the valve lifter.

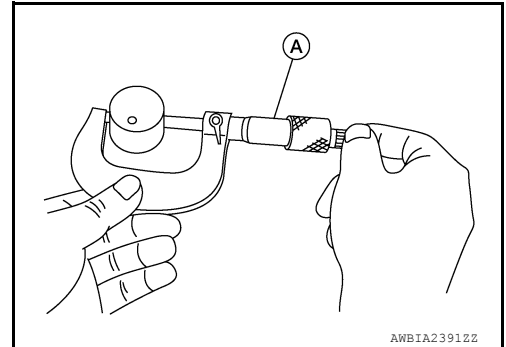

Valve Lifter Bore Diameter

- Using inside micrometer, measure diameter of valve lifter bore of cylinder head. Refer to [EM-137. "Camshaft"](#).
- If out of the specified range, replace the cylinder head assembly.

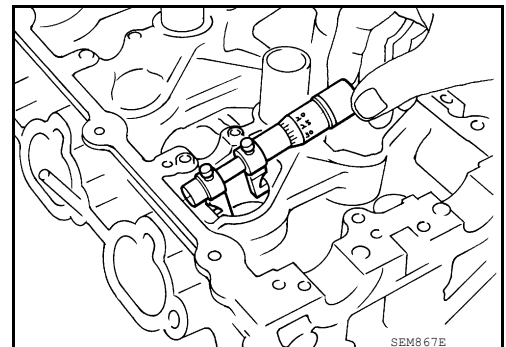

Calculation of Valve Lifter Clearance

- (Valve lifter clearance) = (hole diameter for valve lifter) – (outer diameter of valve lifter) Refer to [EM-137. "Camshaft"](#).
- If out of specified range, replace either or both valve lifter and cylinder head assembly.

CAMSHAFT

< REMOVAL AND INSTALLATION >

Inspection after Installation

INFOID:000000011552721

INSPECTION OF CAMSHAFT SPROCKET (INT) OIL GROOVE

WARNING:

- Check when engine is cold so as to prevent burns from any splashing engine oil.

CAUTION:

- Perform this inspection only when DTC P0011 is detected in self-diagnostic results of CONSULT and it is directed according to inspection procedure of EC section. Refer to [EC-202, "Diagnosis Procedure"](#).

1. Check engine oil level. Refer to [LU-8, "Inspection"](#).
2. Perform the following procedure so as to prevent the engine from being unintentionally started while checking.
 - a. Release fuel pressure. Refer to [EC-166, "Work Procedure"](#).
 - b. Disconnect ignition coil and injector harness connectors, if practical.
3. Remove intake valve timing control solenoid valve.
4. Crank engine, and then make sure that engine oil comes out from intake valve timing control solenoid valve cover oil hole. End cranking after checking.

WARNING:

Be careful not to touch rotating parts (drive belts, idler pulley, and crankshaft pulley, etc.).

CAUTION:

- Engine oil may squirt from intake valve timing control solenoid valve installation hole during cranking. Use a shop cloth to prevent engine oil from splashing on worker, engine components and vehicle.
 - Do not allow engine oil to get on rubber components such as drive belts or engine mount insulators. Immediately wipe off any splashed engine oil.
5. Clean oil groove between oil strainer and intake valve timing control solenoid valve if engine oil does not come out from intake valve timing control solenoid valve cover oil hole.
 6. Remove components between intake valve timing control solenoid valve and camshaft sprocket (INT), and then check each oil groove for clogging.
 - Clean oil groove if necessary.
 7. After inspection, installation of the remaining components is in the reverse order of removal.

OIL SEAL

< REMOVAL AND INSTALLATION >

OIL SEAL

Removal and Installation of Valve Oil Seal

INFOID:000000011557860

REMOVAL

1. Turn crankshaft until the cylinder requiring new oil seals is at TDC. This will prevent valve from dropping into cylinder.

CAUTION:

When rotating crankshaft, be careful to avoid scarring the front cover with the timing chain.

2. Remove camshaft relating to valve oil seal to be removed. Refer to [EM-78, "Removal and Installation"](#).
3. Remove valve lifters.
4. Remove valve collet, valve spring retainer and valve spring using suitable tool (A).

CAUTION:

When working, take care not to damage valve lifter bore.

- Compress valve spring using Tool, attachment and adapter.
Remove valve collet with magnet hand.

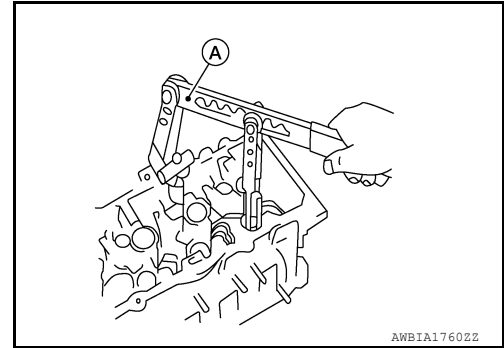

5. Remove valve oil seal using suitable tool (A).

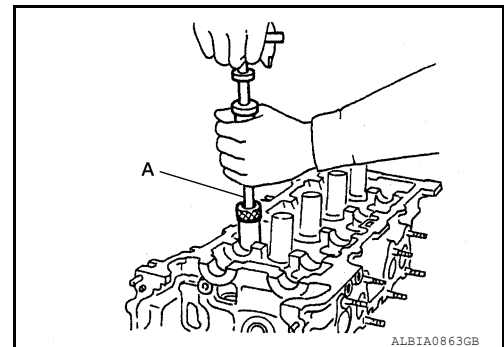

INSTALLATION

1. Apply new engine oil to new valve oil seal joint surface and seal lip.
2. Press in valve oil seal to height (H) using suitable tool (A).

NOTE:

Dimension (H): height measured before valve spring seat installation.

Intake and exhaust (H) : 14.3 - 14.9 mm (0.563 - 0.587 in)

3. Installation of the remaining components is in the reverse order of removal.

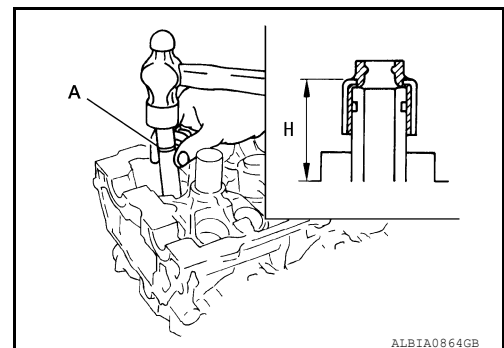

Removal and Installation of Front Oil Seal

INFOID:000000011557861

REMOVAL

1. Remove drive belt. Refer to [EM-14, "Removal and Installation"](#).
2. Lock the drive plate using Tool.

Tool number : — (J-50288)

A
EM
C
D
E
F
G
H
I
J
K
L
M
N
O
P

OIL SEAL

< REMOVAL AND INSTALLATION >

CAUTION:

Do not damage the ring gear teeth or the signal plate teeth behind the ring gear when setting the Tool.

3. Remove the crankshaft pulley as follows:

- Loosen crankshaft pulley and locate bolt seating surface at 10 mm (0.39 in) from its original position.
- Position a pulley puller at recess hole of crankshaft pulley to remove crankshaft pulley.

CAUTION:

Do not use a puller claw on the outer diameter of the crankshaft pulley.

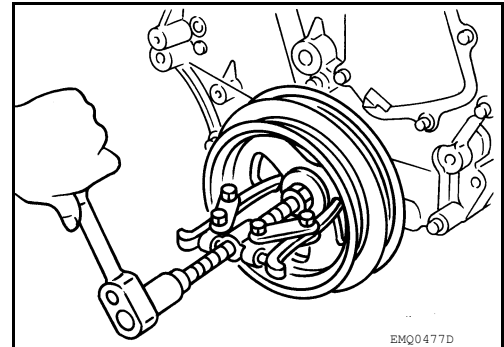

4. Remove front oil seal from front cover using a suitable tool.

CAUTION:

Be careful not to damage front cover or crankshaft.

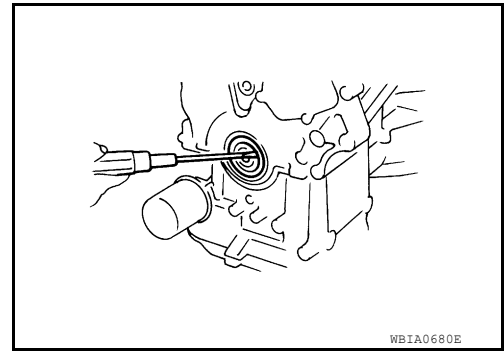

INSTALLATION

1. Apply new engine oil to oil seal lip (C) and dust seal (D) and install.

- Install new oil seal towards the engine inside (B) as shown.

CAUTION:

Press fit straight and avoid causing burrs to engine inside (C) or engine outside (A) or tilting the oil seal.

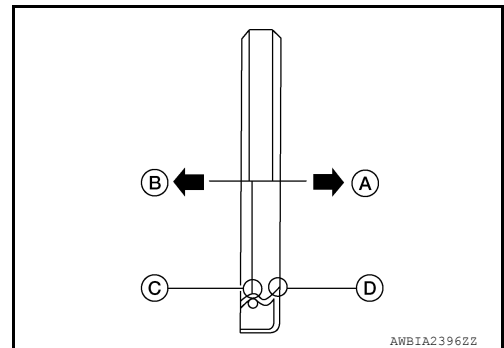

- Press-fit oil seal until it becomes flush with the timing chain case end face, using Tool (A).

Tool number : — (J-37066)

- Make sure the garter spring in the oil seal is in position and seal lip is not inverted.

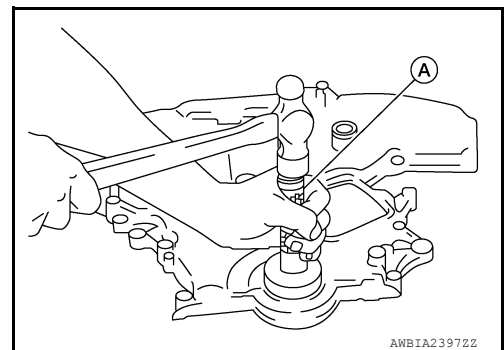

2. Install crankshaft pulley and tighten the bolt in two steps.

- Lubricate thread and seat surface of the bolt with new engine oil.
- For the second step angle tighten using Tool.

CAUTION:

OIL SEAL

< REMOVAL AND INSTALLATION >

- Do not damage the front oil seal when inserting crankshaft pulley.
- Use only brass or plastic hammer if tapping on the crankshaft pulley.
- Do not hammer on pulley grooves.

Step 1 : 44.1 N·m (4.5 kg-m, 33 ft-lb)
Step 2 : 90°(+0°/-6°) degrees clockwise

Tool number : KV10112100 (BT-8653-A)

3. Remove the Tool to unlock the drive plate.

Tool number : — (J-50288)

CAUTION:

Do not damage the ring gear teeth, or the signal plate teeth behind the ring gear, when removing the Tool.

4. Installation of the remaining components is in the reverse order of removal.

Removal and Installation of Rear Oil Seal

INFOID:000000011557862

REMOVAL

1. Remove the upper oil pan. Refer to [EM-39. "Removal and Installation \(Upper Oil Pan\)"](#).
2. Remove drive plate. Refer to [EM-113. "Exploded View"](#).
3. Remove rear oil seal retainer using Tool (A).

Tool Number : KV10111100 (J-37228)

CAUTION:

- Be careful not to damage mating surface.
- If rear oil retainer is removed, replace it with a new one

NOTE:

Rear oil seal and retainer form a single part and are replaced as an assembly.

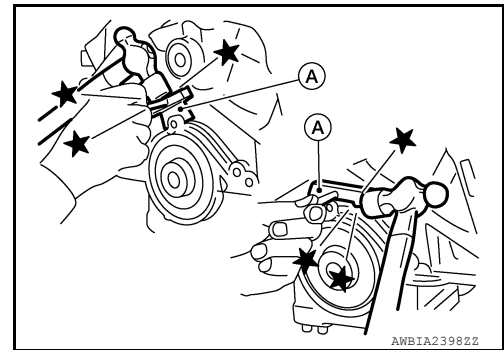

INSTALLATION

1. Remove old liquid gasket material from mating surface of cylinder block and oil pan using a suitable scraper.
2. Install the rear oil seal using Tool (A).

Tool number : — (J-47128)

- a. Loosen the wing nut (B) on the end of the Tool (A).
- b. Insert the arbor (D) into the crankshaft pilot hole until the outer lip (C) of the Tool (A) covers the edge of the crankshaft sealing surface.
- c. Tighten the wing nut (B) to secure the Tool (A) to the crankshaft.

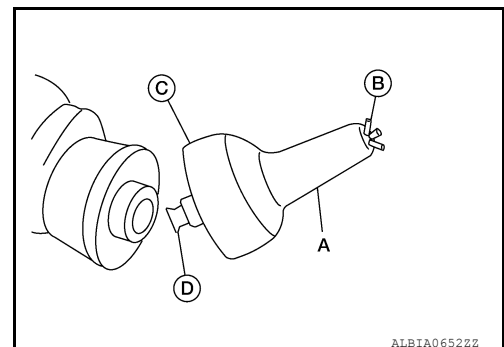

OIL SEAL

< REMOVAL AND INSTALLATION >

- d. Apply sealant to rear oil seal retainer as shown.
Use **Genuine Silicone RTV Sealant** or equivalent. Refer to [GI-22, "Recommended Chemical Products and Sealants"](#).

CAUTION:

- Installation should be done within 5 minutes after applying liquid gasket.
- Do not fill the engine with oil for at least 30 minutes after the components are installed to allow the liquid gasket to cure.

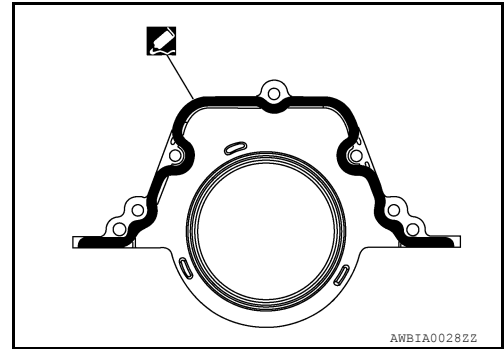

- e. Lubricate the sealing surface of the new rear main seal with new engine oil.
f. Slide the new rear main seal (1) over the Tool (A) and onto the crankshaft.
g. Loosen the wing nut and push the threaded rod into the handle to remove the Tool (A).
h. Tighten the rear oil seal retainer bolts to specification.

Rear oil seal retainer bolts : 8.8 N·m (0.9 kg·m, 78 in-lb)

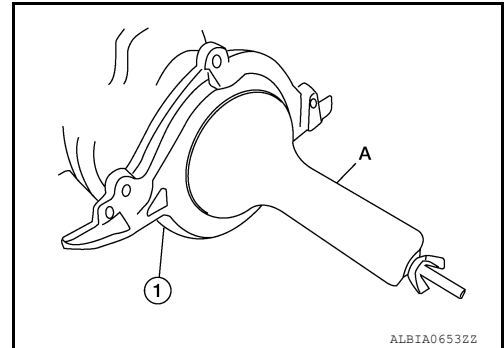

3. Installation of the remaining components is in the reverse order of removal.

CAUTION:

- When replacing an engine or transmission you must make sure the dowels are installed correctly during reassembly.
- Improper alignment caused by missing dowels may cause vibration, oil leaks or breakage of drivetrain components.

CYLINDER HEAD

< REMOVAL AND INSTALLATION >

CYLINDER HEAD

Exploded View

INFOID:000000011557863

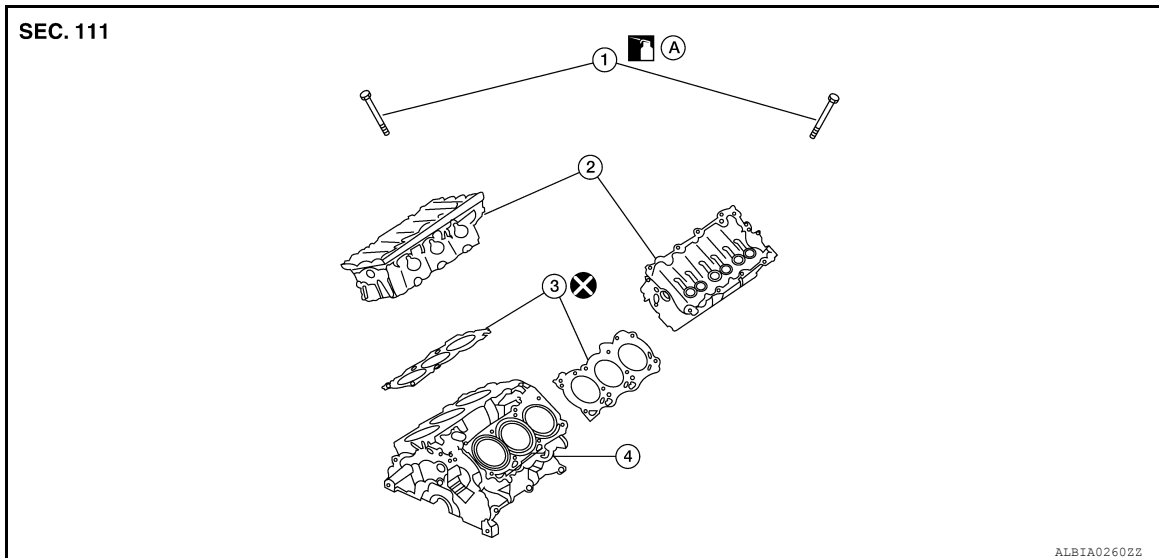

- | | | |
|-----------------------|--------------------------|-------------------------|
| 1. Cylinder head bolt | 2. Cylinder head | 3. Cylinder head gasket |
| 4. Engine block | A. Refer to INSTALLATION | |

Removal and Installation

INFOID:000000011557864

REMOVAL

1. Remove the engine from the vehicle. Refer to [EM-104, "FWD : Removal and Installation"](#) (FWD) or [EM-109, "AWD : Removal and Installation"](#) (AWD).
2. Remove the rear timing chain case. Refer to [EM-73, "Removal and Installation"](#).
3. Remove the intake manifold. Refer to [EM-31, "Removal and Installation"](#).
4. Remove the exhaust manifold and three way catalyst (bank 1/bank 2). Refer to [EM-33, "Exploded View"](#).
5. Remove the intake and exhaust camshafts. Refer to [EM-78, "Removal and Installation"](#).
6. Remove the water outlet housing. Refer to [CO-24, "Exploded View"](#).
7. Remove the bolts from bank 1 cylinder head (A) and bank 2 cylinder head (B).
 - The bolts should be loosened gradually in three stages.
 - Loosen the bolts in the reverse tightening sequence as shown.

← :Engine front

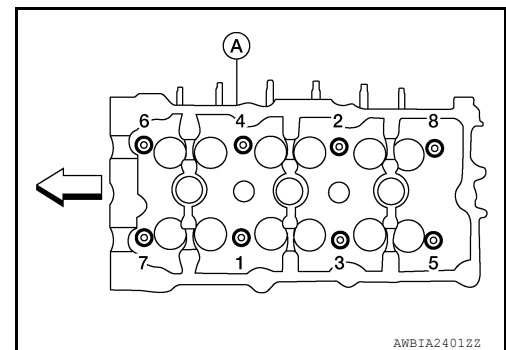

CYLINDER HEAD

< REMOVAL AND INSTALLATION >

8. Remove cylinder head (A) and cylinder head gasket.

CAUTION:

Do not reuse cylinder head gaskets.

← :Engine front

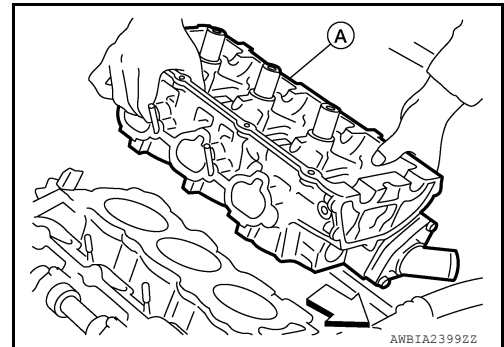
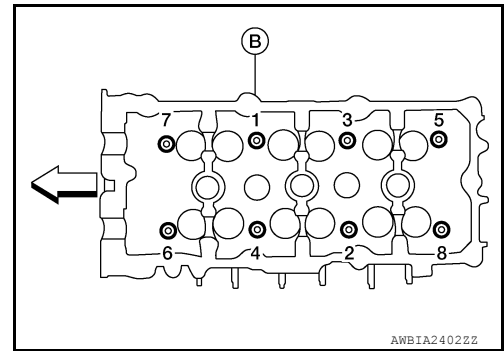

INSTALLATION

1. Turn the crankshaft until No. 1 piston is set at TDC on the compression stroke.
- The crankshaft key (A) should line up with the bank 1 cylinder head center line (B) as shown.

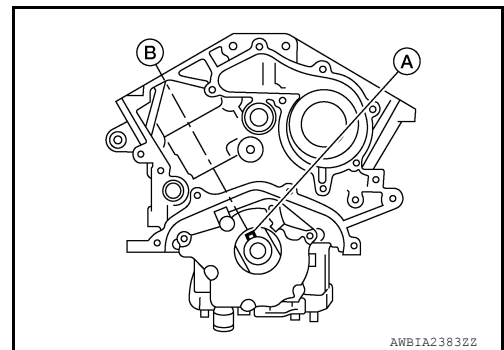

2. Install new cylinder head gaskets.

CAUTION:

Do not reuse cylinder head gaskets.

3. Inspect the cylinder head bolts (B) before installing the cylinder heads.

CAUTION:

Cylinder head bolts (B) are tightened by degree rotation tightening method. Observing measuring points (A), whenever the size difference between d1 and d2 exceeds the limit, replace the bolts with new ones.

Limit (d1 - d2) : 0.11 mm (0.0043 in)

- Lubricate threads and seat surfaces of the bolts with new engine oil.

← :Engine front

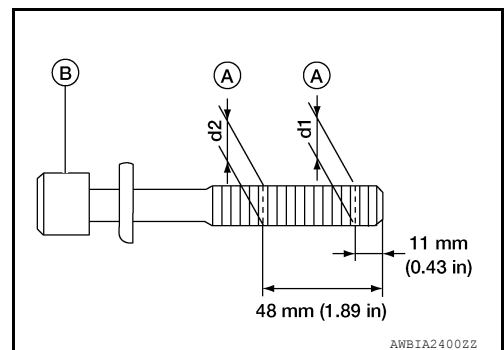

4. Install the bank 1 cylinder head (A) and bank 2 cylinder head (B) on the cylinder block. Tighten the cylinder head bolts in the five steps in the numerical order as shown using Tool.

CAUTION:

Do not rotate crankshaft and camshaft separately or valves will strike piston heads.

CYLINDER HEAD

< REMOVAL AND INSTALLATION >

Tool Number : KV10112100 (BT-8653-A)

• **Tightening procedure:**

Cylinder head bolts

Step 1 : 98.1 N·m (10 kg-m, 72 ft-lb) in order

Step 2 : Loosen bolts in the reverse order of tightening.

Step 3 : 39.2 N·m (4.0 kg-m, 29 ft-lb) in order

Step 4 : 103° degrees rotation in order

Step 5 : 103° degrees rotation in order

← : Engine front

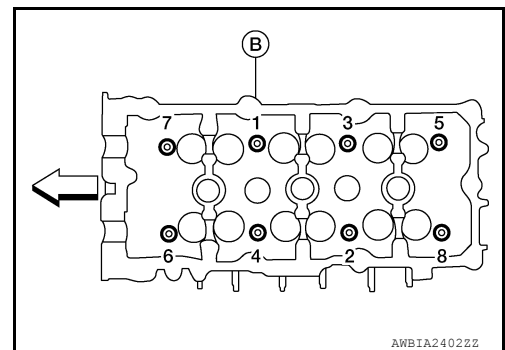
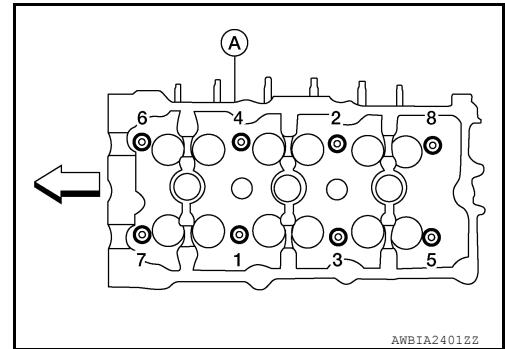

5. Installation of the remaining components is in the reverse order of removal.

A
EM
C
D
E
F
G
H
I
J
K
L
M
N
O
P

CYLINDER HEAD

< REMOVAL AND INSTALLATION >

Disassembly and Assembly

INFOID:000000011557865

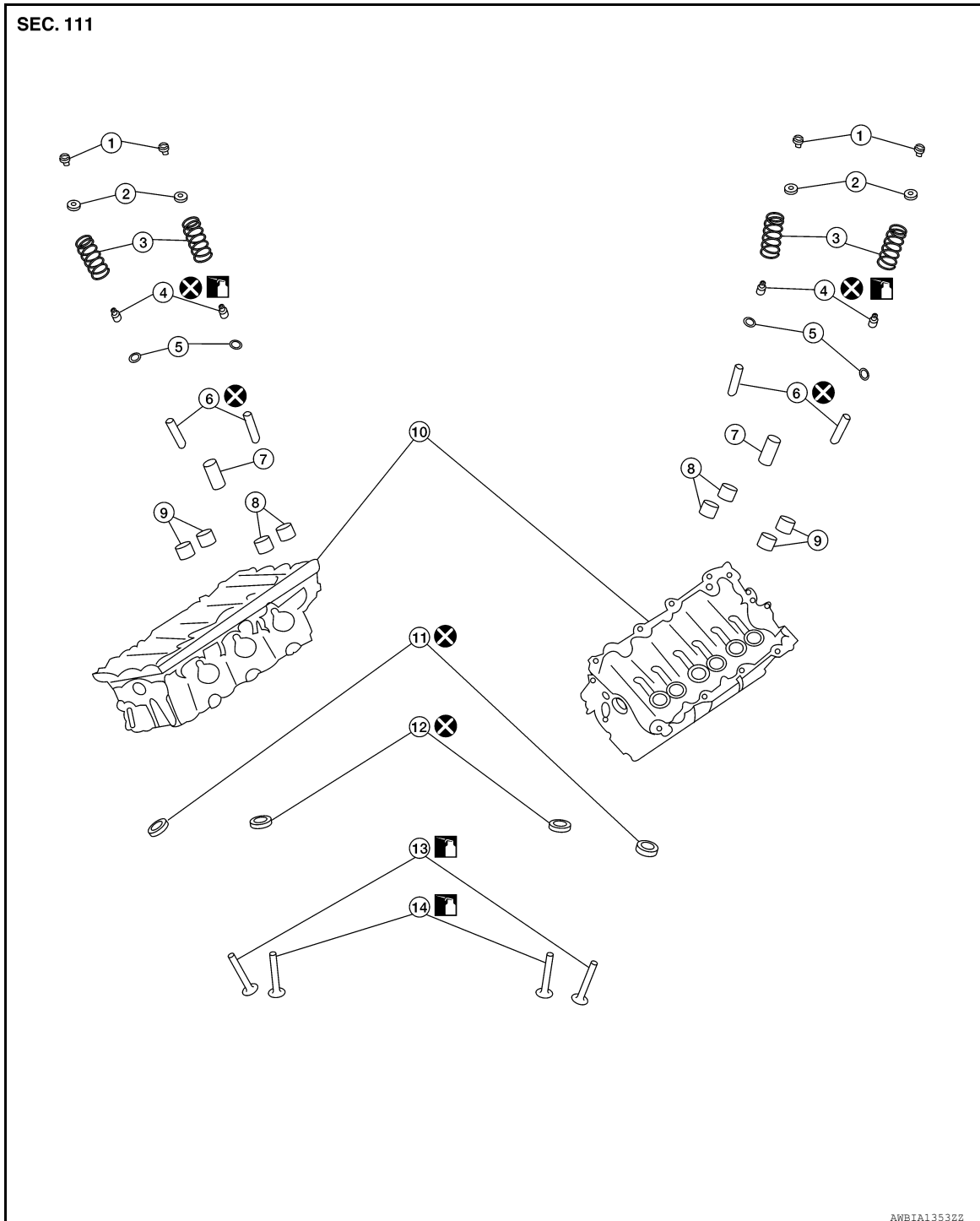

- | | | |
|--------------------|--------------------------|----------------------|
| 1. Valve collet | 2. Valve spring retainer | 3. Valve spring |
| 4. Valve oil seal | 5. Valve spring seat | 6. Valve guide |
| 7. Spark plug tube | 8. Lifter (INT) | 9. Lifter (EXH) |
| 10. Cylinder head | 11. Valve seat (EXH) | 12. Valve seat (INT) |
| 13. Valve (EXH) | 14. Valve (INT) | |

CAUTION:

- When installing camshafts, chain tensioners, oil seals, or other sliding parts, lubricate contacting surfaces with new engine oil.
- Apply new engine oil to threads and seat surface when installing cylinder head, camshaft sprocket, crankshaft pulley, and camshaft bracket.

CYLINDER HEAD

< REMOVAL AND INSTALLATION >

- **Attach tags to valve lifters so as not to mix them up.**

DISASSEMBLY

1. Remove spark plug.
2. Remove valve lifter.
 - Identify installation positions and store them without mixing them up.
3. Remove valve collet.
 - Compress valve spring and remove valve collet with magnet hand using suitable tool (A)

CAUTION:

When working, take care not to damage valve lifter bore.

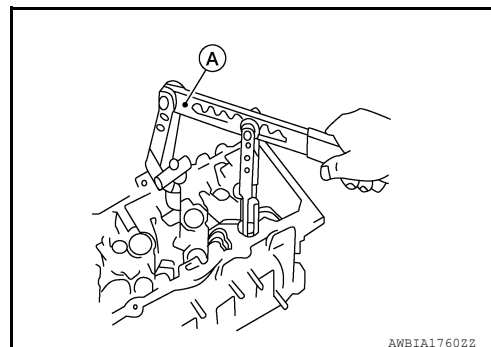

4. Remove valve spring retainer, valve spring and valve spring seat.
5. Push valve stem to combustion chamber side and remove valve.
 - Identify installation positions, and store them without mixing them up.
6. Remove valve oil seals using suitable tool (A).

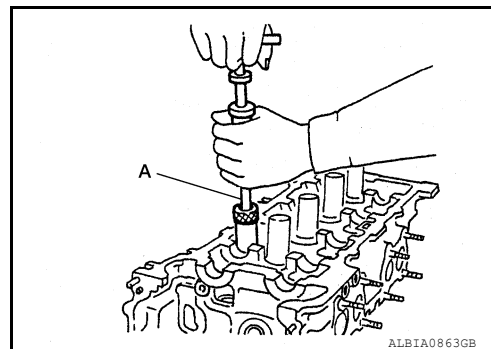

7. If valve seat must be replaced, refer to [EM-96. "Inspection After Disassembly"](#).
 8. If valve guide must be replaced, refer to [EM-96. "Inspection After Disassembly"](#).
 9. Remove spark plug tube, as necessary.
 - Using pair of pliers, pull spark plug tube out of cylinder head.
- CAUTION:**
- **Take care not to damage cylinder head.**
 - **Once removed, spark plug tube will be deformed and cannot be reused. Do not remove it unless absolutely necessary.**

ASSEMBLY

1. When valve guide is removed, install it. Refer to [EM-96. "Inspection After Disassembly"](#).
2. When valve seat is removed, install it. Refer to [EM-96. "Inspection After Disassembly"](#).
3. Install valve oil seals using suitable tool (A).

Height (H) (Without valve spring seat installed)

Intake and exhaust : 14.3 - 14.9 mm (0.563 - 0.587 in)

4. Install valve spring seat.
 5. Install valves.
 - Install it in the original position.
- NOTE:**
Larger diameter valves are for intake side.

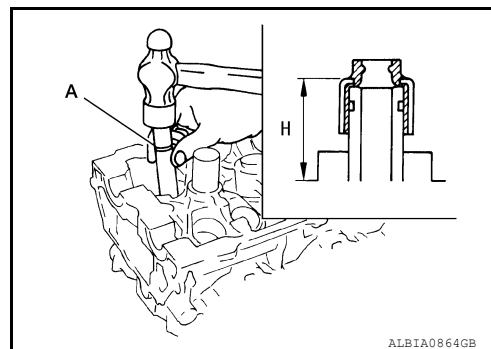

CYLINDER HEAD

< REMOVAL AND INSTALLATION >

6. Install valve spring (uneven pitch type) with narrow pitch (C) end (paint mark) (B) facing cylinder head side (A). Wide pitch (D) end should face away from cylinder head.

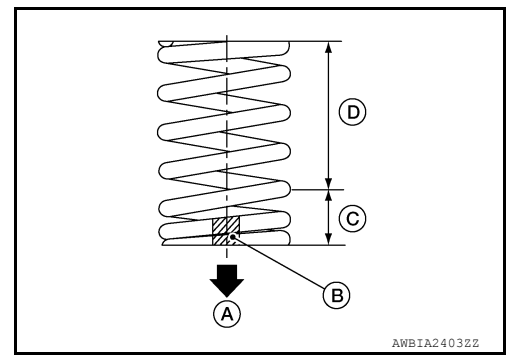

7. Install valve spring retainer.
8. Install valve collet.
- Compress valve spring using suitable tool (A), attachment and adapter. Install valve collet with magnet hand.
- CAUTION:**
- When working, take care not to damage valve lifter bore.**
- Tap valve stem edge lightly with plastic hammer after installation to check its installed condition.

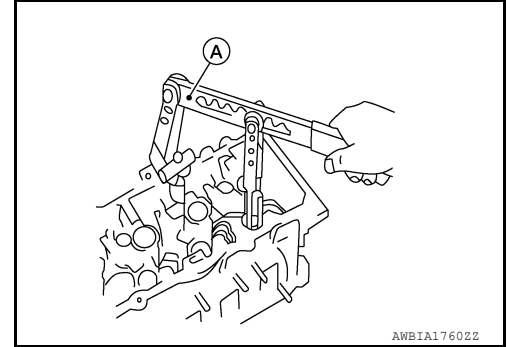

9. Install valve lifter.
- Install it in the original position.
10. Install spark plug tube.
- Press-fit spark plug tube as follows:
- a. Remove old liquid gasket adhering to cylinder head mounting hole.
- b. Apply sealant to area (A) within approximately 12 mm (0.47 in) from edge of spark plug tube press-fit side.
- Use Genuine High Strength Locking Sealant or equivalent. Refer to [GI-22, "Recommended Chemical Products and Sealants"](#).**
- c. Press-fit spark plug tube so that its height (H) is as specified in using suitable tool. Refer to [EM-139, "Cylinder Head"](#).
- CAUTION:**
- **When press-fitting, take care not to deform spark plug tube.**
 - **After press-fitting, wipe off liquid gasket protruding onto cylinder-head upper face.**
11. Install spark plug. Refer to [EM-18, "Removal and Installation"](#).

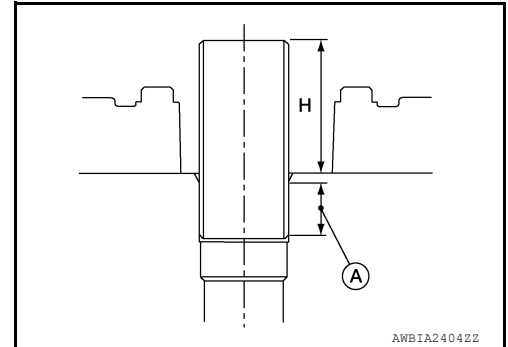

Inspection After Disassembly

INFOID:000000011557866

CYLINDER HEAD DISTORTION

Clean the surface of the cylinder head. Use a reliable straightedge and feeler gauge to check the flatness of cylinder head surface.

CYLINDER HEAD

< REMOVAL AND INSTALLATION >

Check along six positions as shown. Refer to [EM-94. "Disassembly and Assembly"](#)

If it exceeds the limit, replace the cylinder head.

The limit for cylinder head resurfacing is determined by the cylinder block resurfacing. Refer to [EM-139. "Cylinder Head"](#)

After resurfacing cylinder head, check that camshaft rotates freely by hand. If resistance is felt, cylinder head must be replaced.

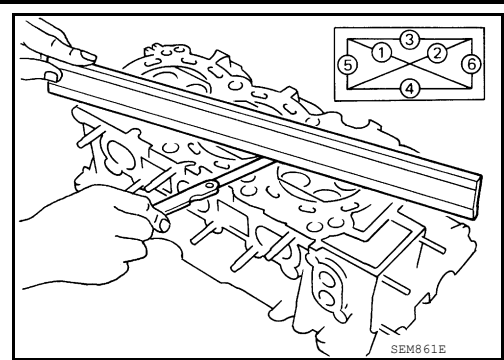

VALVE GUIDE CLEARANCE

1. Measure valve deflection (D) using a suitable tool (C) as shown (Valve and valve guide mostly wear in this direction). Measuring direction (E) should be 90° (B) of camshaft direction (A). Refer to [EM-139. "Cylinder Head"](#).

Maximum deflection : 0.25 mm (0.010 in)

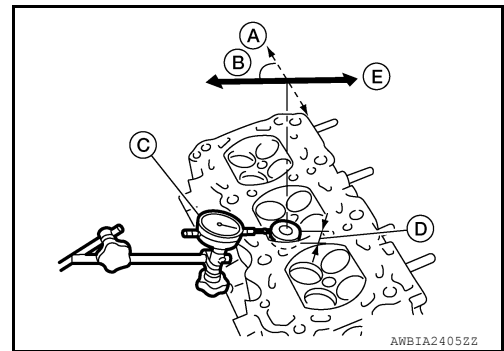

2. If it exceeds the limit, check valve to valve guide clearance with a suitable tool (A).
 - a. Measure valve stem diameter and valve guide inner diameter. Refer to [EM-139. "Cylinder Head"](#).
 - b. Check that clearance is within specification.
(Valve guide clearance) = (Valve guide inner diameter) - (Valve stem diameter). Refer to [EM-139. "Cylinder Head"](#).
 - c. If it exceeds the limit, replace valve or valve guide.

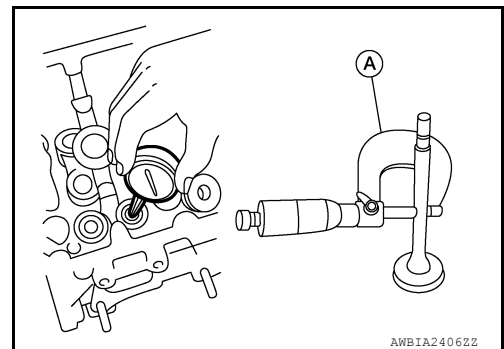

VALVE GUIDE REPLACEMENT

When valve guide is removed, replace with oversized [0.2 mm (0.008 in)] valve guide.

1. To remove valve guide, heat cylinder head to 110 - 130°C (230 - 266°F) by soaking in heated oil (A).

WARNING:

Cylinder head contains heat. When working, wear protective equipment to avoid getting burned.

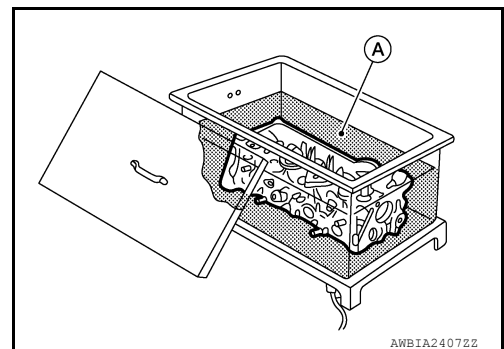

CYLINDER HEAD

< REMOVAL AND INSTALLATION >

2. Drive out the valve guide with a press [under a 20 kN (2.2 US ton) pressure] or hammer and suitable tool.

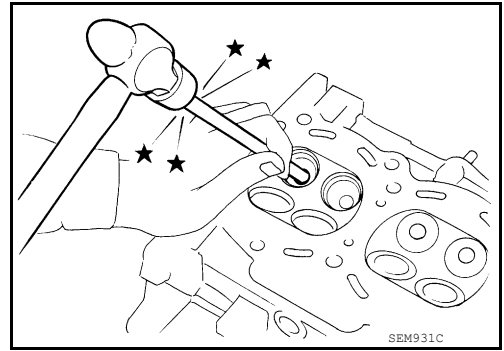

3. Ream cylinder head valve guide hole using suitable tool (A). Refer to [EM-139. "Cylinder Head"](#).

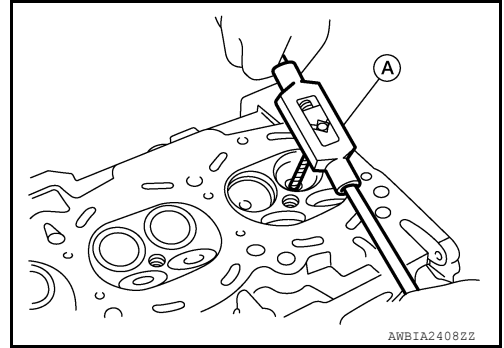

4. Heat cylinder head to 110 - 130°C (230 - 266°F) by soaking in heated oil and press new valve guide from camshaft side into the cylinder head to the dimensions as shown. Refer to [EM-139. "Cylinder Head"](#).

WARNING:

Cylinder head contains heat. When working, wear protective equipment to avoid getting burned.

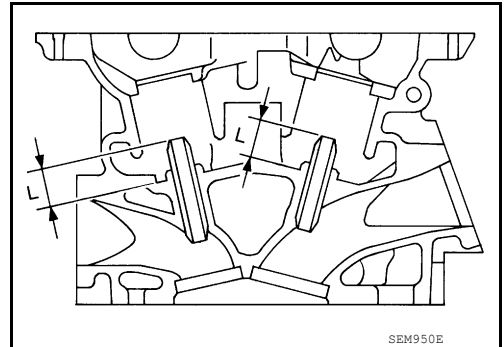

5. Using a suitable tool (A), apply a reamer finish to the valve guide.

**Intake and exhaust : 6.000 - 6.018 mm
finished size (0.2362 - 0.2369 in)**

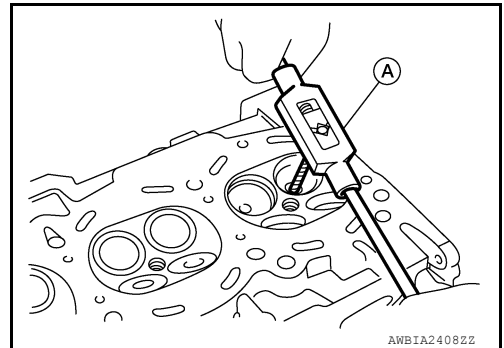

VALVE SEAT CONTACT

CYLINDER HEAD

< REMOVAL AND INSTALLATION >

- After confirming that the dimensions of valve guides and valves are within specifications, perform this procedure.
- Apply Prussian blue onto contacting surface of valve seat to check the condition of the valve contact on the surface.
- Check if the contact area band is continuous all around the circumference.
- If not, grind to adjust valve fitting and check again. If the contacting surface still has NG conditions even after the recheck, replace valve seat.

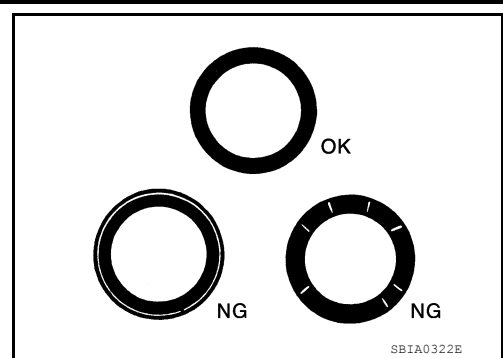

VALVE SEAT REPLACEMENT

1. Bore out old seat (A) until it collapses. Boring should not continue beyond the bottom face of the seat recess in cylinder head. Set the machine depth stop to ensure this.
2. Ream cylinder head recess for service valve seat. Refer to [EM-139. "Cylinder Head"](#)

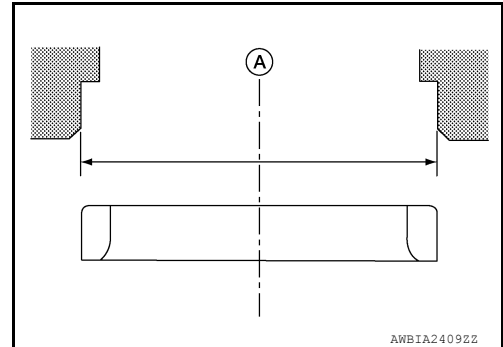

Be sure to ream in circles concentric to the valve guide center. This will enable valve seat to fit correctly.

3. Heat cylinder head to 110 - 130°C (230 - 266°F) by soaking in heated oil.

WARNING:

Cylinder head contains heat. when working, wear protective equipment to avoid getting burned.

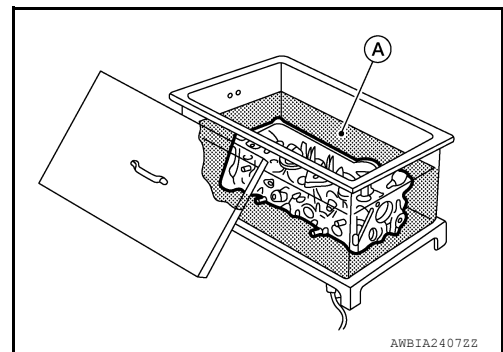

4. Press fit valve seat until it seats on the bottom.
5. Cut or grind valve seat using suitable tool to the specified dimensions. Refer to [EM-139. "Cylinder Head"](#).
6. After cutting, lap valve seat with abrasive compound.
7. Check valve seating condition. Refer to [EM-139. "Cylinder Head"](#).

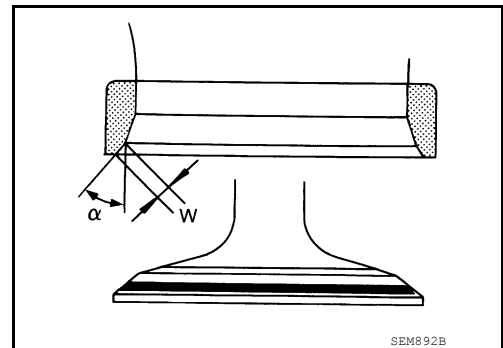

CYLINDER HEAD

< REMOVAL AND INSTALLATION >

- Use a depth gauge to measure the distance between the mounting surface of the cylinder head spring seat and the valve stem end on the exhaust (A) and intake (B) sides. If the distance is shorter than specified, repeat step 5 to adjust it. If it is longer, replace the valve seat with a new one. Refer to [EM-139, "Cylinder Head"](#).

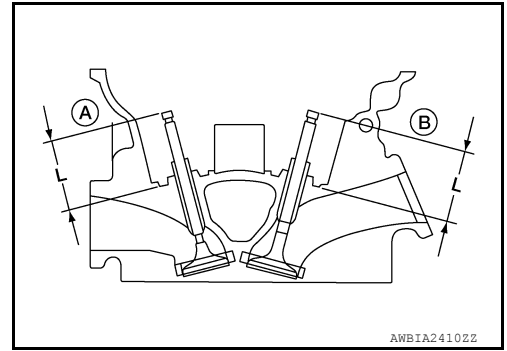

VALVE SPRING SQUARENESS

Set try square (A) along the side of valve spring and rotate the spring. Valve spring should contact (B) the try square (A) (Measure the maximum clearance between the top face of spring and try square. Refer to [EM-139, "Cylinder Head"](#).

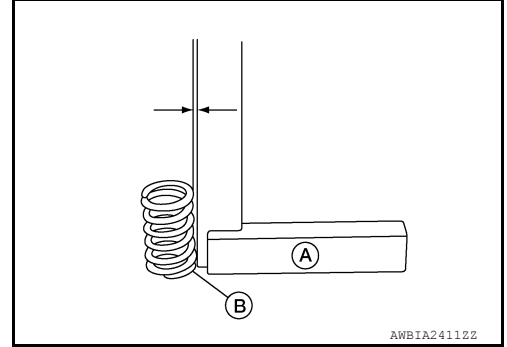

VALVE SPRING DIMENSIONS AND VALVE SPRING PRESSURE LOAD

Check valve spring pressure at specified spring height. If it is not within specifications, replace the spring. Refer to [EM-139, "Cylinder Head"](#).

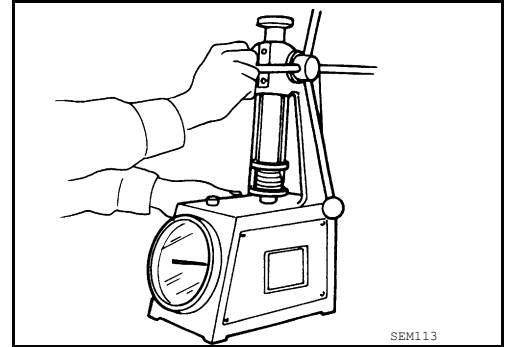

ENGINE MOUNT

< REMOVAL AND INSTALLATION >

ENGINE MOUNT

ENGINE MOUNT (FRONT)

ENGINE MOUNT (FRONT) : Removal and Installation

INFOID:000000011220679

A

EM

WARNING:

- Situate the vehicle on a flat and solid surface.
- Place chocks at front and back of rear wheels.

CAUTION:

- Always work safely.
- Do not start work until the engine and exhaust system are cooled completely.
- Refer to the applicable sections for warnings, cautions, notes, and instructions if necessary procedures are not included in this section.

NOTE:

When removing components such as hoses, tubes/lines, etc., cap or plug openings to prevent fluid from spilling.

REMOVAL

1. Remove the air cleaner case (upper), air cleaner case (lower), front air duct, and air duct hose and resonator assembly. Refer to [EM-26, "Removal and Installation"](#).
2. Remove the battery and battery tray assembly. Refer to [PG-88, "Removal and Installation"](#).
3. Remove the engine under cover. Refer to [EXT-40, "FRONT UNDER COVER : Removal and Installation"](#).
4. Remove the fender protector side covers (RH/LH). Refer to [EXT-36, "FENDER PROTECTOR : Exploded View"](#).
5. Partially remove the fender protectors (RH/LH). Refer to [EXT-36, "FENDER PROTECTOR : Exploded View"](#).
6. Remove the radiator assembly. Refer to [CO-13, "Removal and Installation"](#).
7. Remove the engine cooling fan shroud and motor assembly. Refer to [CO-15, "Removal and Installation"](#).
8. Remove the exhaust manifold heat shield (LH). Refer to [EM-33, "Exploded View"](#).
9. Support the engine with a suitable tool.
10. Disconnect the engine mount insulator (front) vacuum hose.
11. Remove the engine mount insulator (front) nut (A).

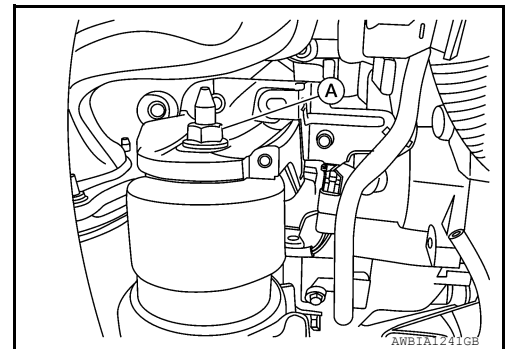

12. Loosen the engine mount bracket (front) bolts in the reverse order shown.

← : Engine front

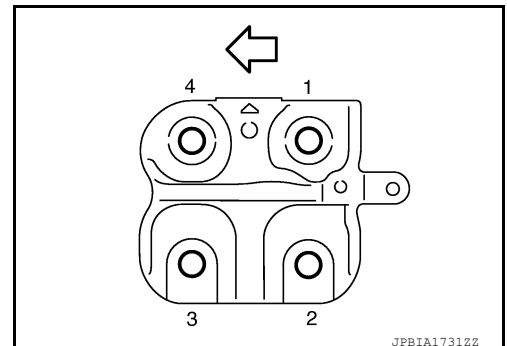

13. Remove the engine mount bracket (front).

ENGINE MOUNT

< REMOVAL AND INSTALLATION >

14. Remove the engine mount insulator (front) bolts in the reverse order as shown.

⇐ : Front

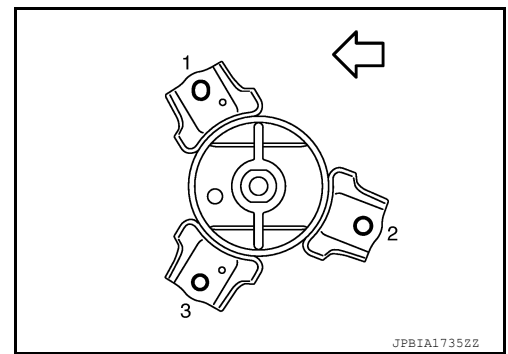

15. Remove the engine mount insulator (front).

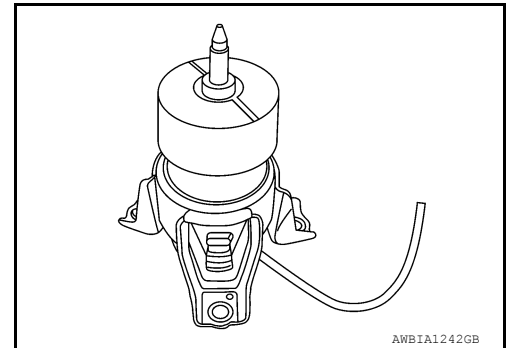

INSTALLATION

CAUTION:

- Do not damage or spill engine oil on the engine mount insulator (front).
- Check engine mount insulator (front) is seated properly before tightening.

1. Install the engine mount insulator (front).

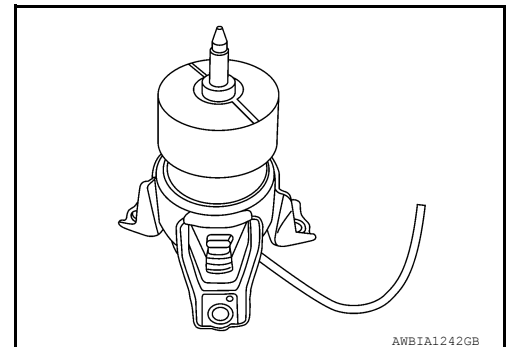

2. Install the engine mount insulator (front) bolts and tighten to specification in the order shown.

⇐ : Front

Engine mount insulator (front) bolts : 55 N·m (5.6 kg-m, 41 ft-lb)

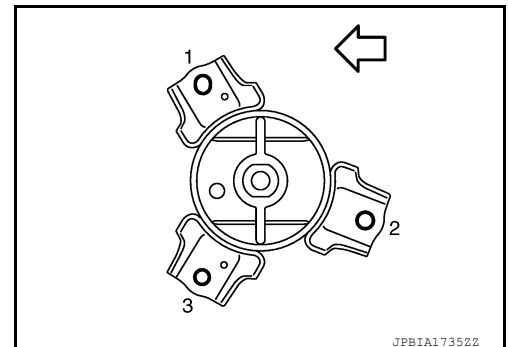

3. Install the engine mount bracket (front) to the engine block.

ENGINE MOUNT

< REMOVAL AND INSTALLATION >

4. Tighten the engine mount bracket (front) bolts to specification in the order shown.

↶ : Engine front

Engine mount bracket (front) bolts : 40 N·m (4.1 kg-m, 30 ft-lb)

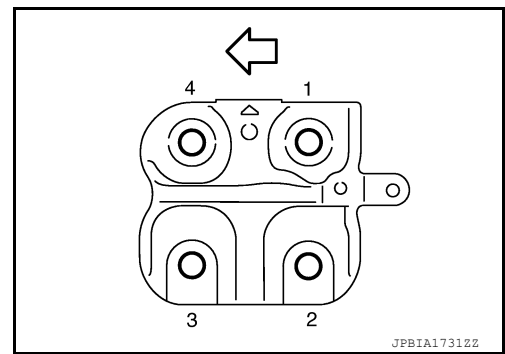

5. Install the engine mount insulator (front) nut (A) and tighten to specification.

Engine mount insulator (front) nut : 103 N·m (11 kg-m, 76 ft-lb)

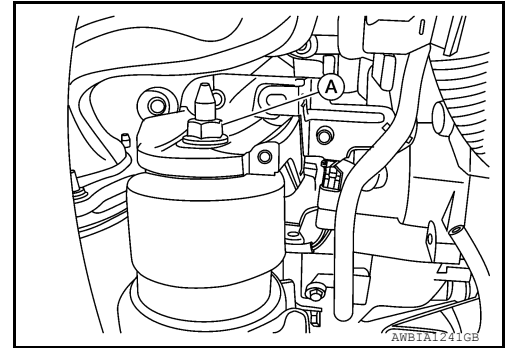

6. Installation of the remaining components is in the reverse order of removal.

A
EM
C
D
E
F
G
H
I
J
K
L
M
N
O
P

ENGINE ASSEMBLY

< UNIT REMOVAL AND INSTALLATION >

UNIT REMOVAL AND INSTALLATION

ENGINE ASSEMBLY

FWD

FWD : Exploded View

INFOID:000000011220680

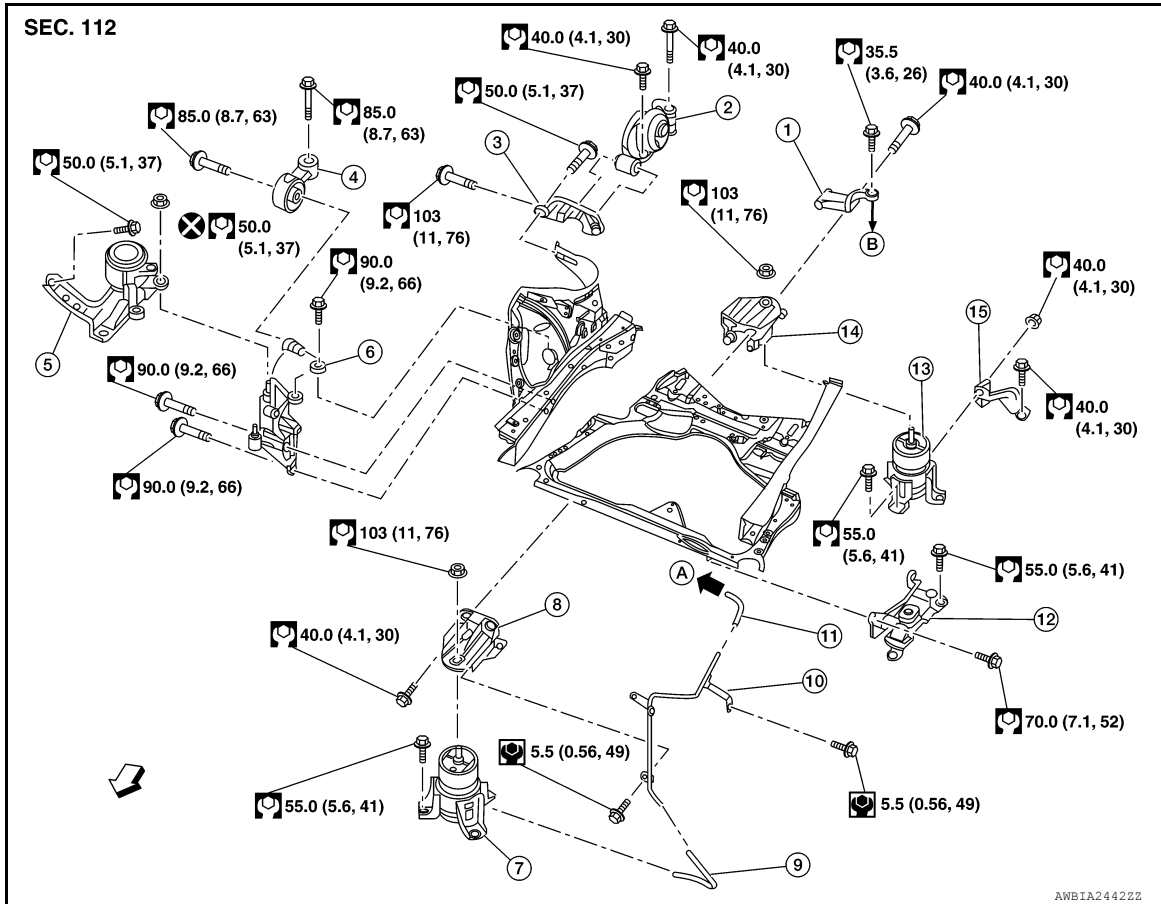

- | | | |
|---|------------------------------------|------------------------------------|
| 1. Gusset | 2. Rear torque rod | 3. Rear torque rod bracket |
| 4. Upper torque rod | 5. Engine mounting insulator (RH) | 6. Engine mounting bracket (RH) |
| 7. Engine mounting insulator (front) | 8. Engine mounting bracket (front) | 9. Vacuum hose |
| 10. Vacuum tube (front) | 11. Vacuum hose | 12. Engine mounting insulator (LH) |
| 13. Engine mounting insulator (rear) | 14. Engine mounting bracket (rear) | 15. Engine mounting stay (rear) |
| A. To electronic controlled engine mount control solenoid valve | B. To transmission | ⇐ Front |

FWD : Removal and Installation

INFOID:000000011220681

WARNING:

- Situate the vehicle on a flat and solid surface.
- Place chocks at front and back of rear wheels.
- For engines not equipped with engine slingers, attach proper slingers and bolts described in PARTS CATALOG.

CAUTION:

- Always work safely.
- Do not start work until the engine and exhaust system are cooled completely.
- Refer to the applicable sections for warnings, cautions, notes, and instructions if necessary procedures are not included in the engine section.

ENGINE ASSEMBLY

< UNIT REMOVAL AND INSTALLATION >

- For supporting, lifting and jacking points, refer to [GI-29, "Garage Jack and Safety Stand and 2-Pole Lift"](#).
- Always use the support point specified for lifting.
- Support the vehicle at the rear axle jacking point with transmission jack or similar tool before removing the engine in preparation for the backward shift of the center of gravity.

NOTE:

When removing components such as hoses, tubes/lines, etc., cap or plug openings to prevent fluid from spilling.

REMOVAL

Outline

Remove the engine and transmission with the front suspension member as a unit. Separate the engine from the transmission and remove from the front suspension member.

Preparation

1. Release fuel pressure. Refer to [EC-166, "Work Procedure"](#).
2. Drain engine coolant. Refer to [CO-9, "Changing Engine Coolant"](#).
CAUTION:
 - Perform this step when the engine is cold.
 - Do not allow the engine coolant to contact the drive belts.
3. Remove the front under cover. Refer to [EXT-40, "FRONT UNDER COVER : Removal and Installation"](#).
4. Remove the front road wheels and tires. Refer to [WT-68, "Removal and Installation"](#).
5. Remove the fender protector (LH/RH): Refer to [EXT-36, "FENDER PROTECTOR : Removal and Installation"](#).

Engine Room

1. Remove cowl top and cowl top extension. Refer to [EXT-34, "Exploded View"](#).
2. Remove the air duct (inlet), air cleaner cases (upper and lower) with mass air flow sensor and air duct assembly. Refer to [EM-26, "Exploded View"](#).
3. Remove the engine room cover. Refer to [EM-25, "Removal and Installation"](#).
4. Drain the power steering fluid. Refer to [ST-30, "Draining and Refilling"](#).
5. Disconnect engine room harness at the CVT and ECM connectors.
CAUTION:
Protect the harness connector with plastic bags or suitable covering to help prevent damage and intrusion of foreign materials into the connectors.
6. Remove the battery tray. Refer to [PG-86, "Removal and Installation"](#).
7. Disconnect heater hoses (engine side). Refer to [HA-43, "Removal and Installation"](#).
8. Remove upper and lower radiator hoses. Refer to [CO-13, "Exploded View"](#).
9. Remove high pressure pipe, low pressure pipe, high pressure flexible hose, and low pressure flexible hose. Refer to [HA-33, "Exploded View"](#).
10. Remove EVAP hose.
11. Disconnect fuel feed hose quick connector at fuel tube side. Refer to [EM-49, "Exploded View"](#).
12. Disconnect CVT control cable. Refer to [TM-196, "Exploded View"](#).
13. Disconnect brake booster vacuum hose at brake booster. Refer to [BR-32, "Exploded View"](#).
14. Remove harness ground cable.
15. Disconnect low pressure hose from steering pump. Refer to [ST-40, "Removal and Installation"](#).
16. Disconnect high pressure piping from steering pump. Refer to [ST-40, "Removal and Installation"](#).
17. Disconnect the wiring harness from the distribution/fuse block.
18. Disconnect the CVT fluid cooler hoses from the CVT.
19. Remove the upper RH upper torque rod.
20. Remove engine mounting insulator (RH) three upper nuts.

Vehicle Underbody

1. Remove exhaust front tube. Refer to [EX-5, "Exploded View"](#).

ENGINE ASSEMBLY

< UNIT REMOVAL AND INSTALLATION >

2. Disconnect steering lower joint at power steering gear assembly and release steering lower shaft. Refer to [ST-42, "Exploded View"](#).
3. Disconnect front stabilizer connecting rod. Refer to [FSU-15, "Exploded View"](#).
4. Remove front brake caliper assemblies with piping connected and position them aside. Refer to [BR-38, "BRAKE CALIPER ASSEMBLY : Removal and Installation"](#).
5. Remove rear plate cover from oil pan (upper). Then remove nuts attaching the drive plate to the torque converter. Refer to [EM-134, "Dowel Pin Alignment"](#).
6. Remove crankshaft position sensor (POS). Refer to [EM-38, "Exploded View"](#).
CAUTION:
 - Handle carefully to avoid dropping and shocks.
 - Do not disassemble.
 - Do not allow metal powder to adhere to magnetic part at sensor tip.
 - Do not place sensors in a location where they are exposed to magnetism.

Removal

1. Use suitable tool to securely support bottom of front suspension member.
CAUTION:
Put a piece of wood or something similar as the supporting surface to secure a completely stable condition.

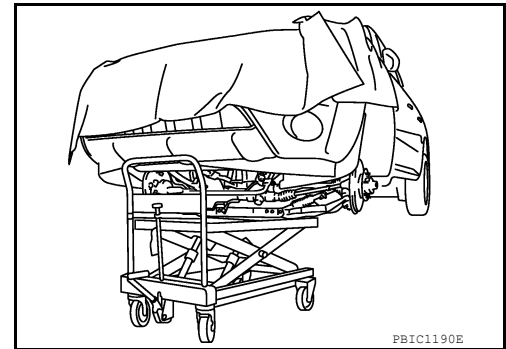

2. Remove front suspension member mounting nuts and bolts. Refer to [FSU-20, "Exploded View"](#).
3. Carefully lower table to remove the engine, the transmission and the front suspension member. When performing work, observe the following caution:
CAUTION:
 - Confirm there is no interference with the vehicle.
 - Repeatedly check to ensure all harnesses are disconnected before and during engine removal.
 - Check all connection points have been disconnected.
 - Keep in mind the center of vehicle gravity changes. If necessary, use jack(s) to support the vehicle at rear jacking point(s) to prevent it from falling off the lift.

Separation

ENGINE ASSEMBLY

< UNIT REMOVAL AND INSTALLATION >

1. Install engine slingers into front of cylinder head (bank 1) (3) and rear of cylinder head (bank 2) (2).

- (1). : Engine rear slinger
- (2). : Engine front slinger (upper)
- (3). : Engine front slinger (lower)
- ⇐ : Engine front

A. : 28.0 N·m (2.9 kg-m, 21 ft-lb)

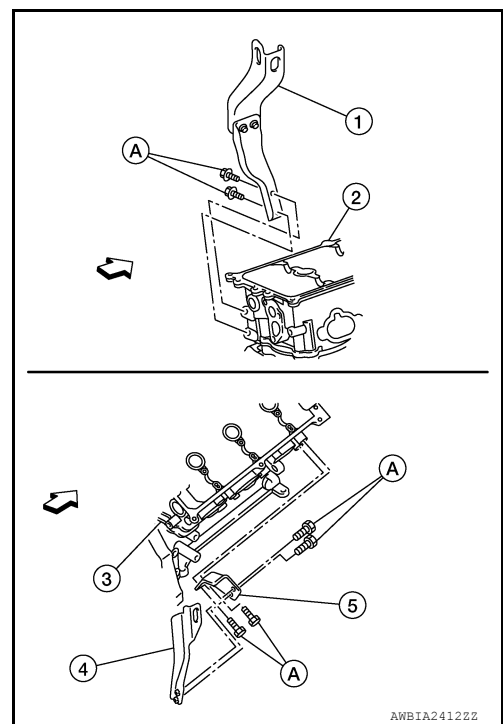

2. Disconnect vacuum hose from front engine mounting insulator.
3. Remove CVT fluid level indicator and CVT charging pipe. Refer to [TM-219, "Exploded View"](#).
4. Remove starter. Refer to [STR-20, "Removal and Installation"](#).
5. Remove front drive shaft (LH/RH). Refer to [FAX-19, "Removal and Installation \(LH\)"](#) and [FAX-21, "Removal and Installation \(RH\)"](#).
6. Remove coolant reservoir.
7. Remove engine mounting insulator (rear).
8. Disconnect CVT unit harness connector from CVT.
9. Remove transmission to engine bolts. Refer to [TM-219, "Exploded View"](#).
10. Separate engine and transmission assembly. Refer to [TM-220, "Removal and Installation"](#).
11. Lift the engine from the front suspension member.
CAUTION:
 - Repeatedly check to ensure all harnesses are disconnected before and during engine lifting.
 - Avoid spilling engine oil or grease onto the engine mounting insulators to prevent damage to engine mounting insulators.

INSTALLATION

Installation is in the reverse order of removal.

CAUTION:

- Do not damage the engine mounting insulator. Do not spill engine oil on the engine mounting insulator.
- Check all mounting insulators are seated properly, then tighten nuts and bolts.

INSPECTION AFTER INSTALLATION

- Before starting engine, check oil/fluid levels including engine coolant and engine oil. If there is less than required quantity, fill to the specified level. Refer to [MA-11, "Fluids and Lubricants"](#).
- Use procedure below to check for fuel leakage.
- Turn ignition switch ON (with engine stopped). With fuel pressure applied to fuel piping, check for fuel leakage at connection points.
- Start engine. With engine speed increased, check again for fuel leakage at connection points.
- Run engine to check for unusual noise and vibration.

NOTE:

If hydraulic pressure inside timing chain tensioner drops after removal and installation, slack in the guide may generate a pounding noise during and just after engine start. However, this is normal. Noise will stop after hydraulic pressure rises.

ENGINE ASSEMBLY

< UNIT REMOVAL AND INSTALLATION >

- Warm up engine thoroughly to make sure there is no leakage of fuel, exhaust gas, or any oils/fluids including engine oil and engine coolant.
- Bleed air from passages in lines and hoses, such as in cooling system.
- After cooling down engine, again check oil/fluid levels including engine oil and engine coolant. Refill to specified level, if necessary.
- Summary of the inspection items:

Item		Before starting engine	Engine running	After engine stopped
Engine coolant		Level	Leakage	Level
Engine oil		Level	Leakage	Level
Transmission/ transaxle fluid	A/T and CVT Models	Leakage	Level/Leakage	Leakage
	M/T Models	Level/Leakage	Leakage	Level/Leakage
Other oils and fluids*		Level	Leakage	Level
Fuel		Leakage	Leakage	Leakage
Exhaust gas		—	Leakage	—

*Power steering fluid, brake fluid, etc.

AWD

AWD : Exploded View

INFOID:000000011220682

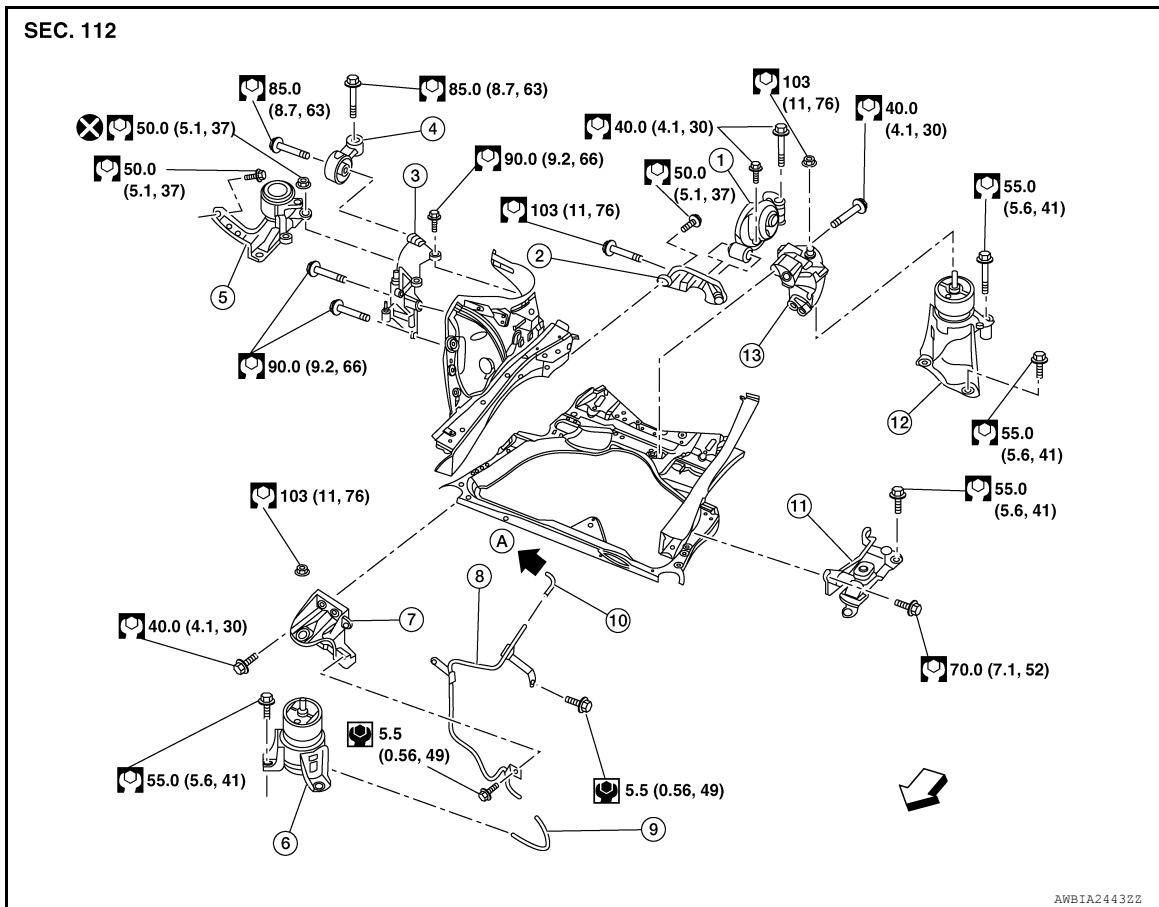

- | | | |
|------------------------------------|---|--------------------------------------|
| 1. Rear torque rod | 2. Rear torque rod bracket | 3. Engine mounting bracket (RH) |
| 4. Upper torque rod | 5. Engine mounting insulator (RH) | 6. Engine mounting insulator (front) |
| 7. Engine mounting bracket (front) | 8. Vacuum tube (front) | 9. Vacuum hose |
| 10. Vacuum hose | 11. Engine mounting insulator (LH) | 12. Engine mounting insulator (rear) |
| 13. Rear engine mount bracket (LH) | A. To electronic controlled engine mount control solenoid valve | ⇐ Front |

ENGINE ASSEMBLY

< UNIT REMOVAL AND INSTALLATION >

AWD : Removal and Installation

INFOID:000000011220683

WARNING:

- Situate the vehicle on a flat and solid surface.
- Place chocks at front and back of rear wheels.
- For engines not equipped with engine slingers, attach proper slingers and bolts described in PARTS CATALOG.

CAUTION:

- Always work safely.
- Do not start work until the engine and exhaust system are cooled completely.
- Refer to the applicable sections for warnings, cautions, notes, and instructions if necessary procedures are not included in the engine section.
- For supporting, lifting and jacking points, refer to [GI-29, "Garage Jack and Safety Stand and 2-Pole Lift"](#).
- Always use the support point specified for lifting.
- Support the vehicle at the rear axle jacking point with transmission jack or similar tool before removing the engine in preparation for the backward shift of the center of gravity.

NOTE:

When removing components such as hoses, tubes/lines, etc., cap or plug openings to prevent fluid from spilling.

REMOVAL

Outline

Remove the engine and transmission with the front suspension member as a unit. Separate the engine from the transmission and remove from the front suspension member.

Preparation

1. Release fuel pressure. Refer to [EC-166, "Work Procedure"](#).
2. Drain engine coolant. Refer to [CO-9, "Changing Engine Coolant"](#).
CAUTION:
 - Perform this step when the engine is cold.
 - Do not allow the engine coolant to contact the drive belts.
3. Remove the front under cover. Refer to [EXT-40, "FRONT UNDER COVER : Removal and Installation"](#).
4. Remove the front road wheels and tires. Refer to [WT-68, "Removal and Installation"](#).
5. Remove the fender protector (LH/RH): Refer to [EXT-36, "FENDER PROTECTOR : Removal and Installation"](#).

Engine Room

1. Remove cowl top and cowl top extension. Refer to [EXT-34, "Exploded View"](#).
2. Remove the air duct (inlet), air cleaner cases (upper and lower) with mass air flow sensor and air duct assembly. Refer to [EM-26, "Exploded View"](#).
3. Remove the engine room cover. Refer to [EM-25, "Removal and Installation"](#).
4. Remove coolant reservoir.
5. Drain the power steering fluid. Refer to [ST-30, "Draining and Refilling"](#).
6. Disconnect engine room harness at the CVT and ECM connectors.
CAUTION:
Protect the harness connector with plastic bags or suitable covering to help prevent damage and intrusion of foreign materials into the connectors.
7. Remove the battery tray. Refer to [PG-86, "Removal and Installation"](#).
8. Disconnect heater hoses (engine side). Refer to [HA-43, "Removal and Installation"](#).
9. Remove upper and lower radiator hoses. Refer to [CO-13, "Exploded View"](#).
10. Remove high pressure pipe, low pressure pipe, high pressure flexible hose, and low pressure flexible hose. Refer to [HA-33, "Exploded View"](#).
11. Remove EVAP hose.
12. Disconnect fuel feed hose quick connector at fuel tube side. Refer to [EM-49, "Exploded View"](#).
13. Disconnect CVT control cable. Refer to [TM-196, "Exploded View"](#).

ENGINE ASSEMBLY

< UNIT REMOVAL AND INSTALLATION >

14. Disconnect brake booster vacuum hose at brake booster. Refer to [BR-32, "Exploded View"](#).
15. Remove harness ground cable.
16. Disconnect low pressure hose from steering pump. Refer to [ST-40, "Removal and Installation"](#).
17. Disconnect high pressure piping from steering pump. Refer to [ST-40, "Removal and Installation"](#).
18. Disconnect the wiring harness from the distribution/fuse block.
19. Disconnect the CVT fluid cooler hoses from the CVT.
20. Remove the upper RH upper torque rod.
21. Remove engine mounting insulator (RH) three upper nuts.

Vehicle Underbody

1. Remove exhaust front tube. Refer to [EX-5, "Exploded View"](#).
2. Remove rear propeller shaft. Refer to [DLN-89, "Removal and Installation"](#).
3. Disconnect steering lower joint at power steering gear assembly and release steering lower shaft. Refer to [ST-42, "Exploded View"](#).
4. Disconnect front stabilizer connecting rod. Refer to [FSU-15, "Exploded View"](#).
5. Remove front brake caliper assemblies with piping connected and position them aside. Refer to [BR-38, "BRAKE CALIPER ASSEMBLY : Removal and Installation"](#).
6. Remove rear plate cover from oil pan (upper). Then remove nuts attaching the drive plate to the torque converter. Refer to [EM-134, "Dowel Pin Alignment"](#).
7. Remove crankshaft position sensor (POS). Refer to [EM-38, "Exploded View"](#).

CAUTION:

- Handle carefully to avoid dropping and shocks.
- Do not disassemble.
- Do not allow metal powder to adhere to magnetic part at sensor tip.
- Do not place sensors in a location where they are exposed to magnetism.

Removal

1. Use suitable tool to securely support bottom of front suspension member.

CAUTION:

Put a piece of wood or something similar as the supporting surface to secure a completely stable condition.

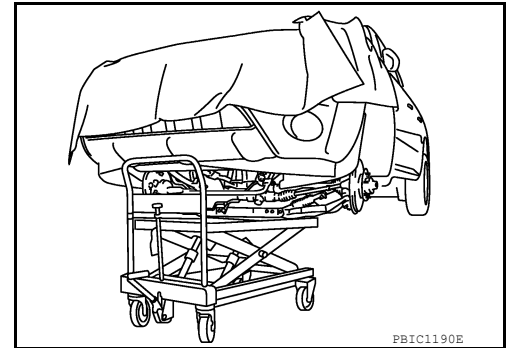

PBIC1190E

2. Remove front suspension member mounting nuts and bolts. Refer to [FSU-20, "Exploded View"](#).
3. Carefully lower table to remove the engine, the transmission and the front suspension member. When performing work, observe the following caution:

CAUTION:

- Confirm there is no interference with the vehicle.
- Repeatedly check to ensure all harnesses are disconnected before and during engine removal.
- Check all connection points have been disconnected.
- Keep in mind the center of vehicle gravity changes. If necessary, use jack(s) to support the vehicle at rear jacking point(s) to prevent it from falling off the lift.

Separation

ENGINE ASSEMBLY

< UNIT REMOVAL AND INSTALLATION >

1. Install engine slingers into front of cylinder head (bank 1) (3) and rear of cylinder head (bank 2) (2).

- (1). : Engine rear slinger
- (2). : Engine front slinger (upper)
- (3). : Engine front slinger (lower)
- ⇐ : Engine front

A. : 28.0 N·m (2.9 kg·m, 21 ft·lb)

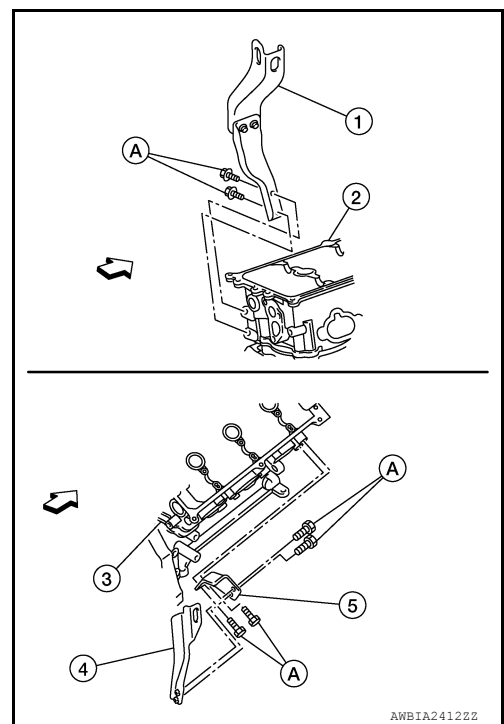

2. Disconnect vacuum hose from front engine mounting insulator.
3. Remove CVT fluid level indicator and CVT charging pipe. Refer to [TM-219, "Exploded View"](#).
4. Remove starter. Refer to [STR-20, "Removal and Installation"](#).
5. Remove exhaust manifold and three way catalyst. Refer to [EM-33, "Exploded View"](#).
6. Remove front drive shaft (LH/RH). Refer to [FAX-19, "Removal and Installation \(LH\)"](#) and [FAX-21, "Removal and Installation \(RH\)"](#).
7. Remove nut from engine mounting insulator (rear). Refer to [EM-108, "AWD : Exploded View"](#).
8. Remove nut from engine mounting insulator (front). Refer to [EM-108, "AWD : Exploded View"](#).
9. Disconnect CVT unit harness connector from CVT.
10. Remove transfer assembly. Refer to [DLN-60, "Removal and Installation"](#).
11. Remove transmission to engine bolts. Refer to [TM-219, "Exploded View"](#).
12. Separate engine and transmission assembly. Refer to [TM-220, "Removal and Installation"](#).
13. Lift the engine from the front suspension member.

CAUTION:

- Repeatedly check to ensure all harnesses are disconnected before and during engine lifting.
- Avoid spilling engine oil or grease onto the engine mounting insulators to prevent damage to engine mounting insulators.

INSTALLATION

Installation is in the reverse order of removal.

CAUTION:

- Do not damage the engine mounting insulator. Do not spill engine oil on the engine mounting insulator.
- Check all mounting insulators are seated properly, then tighten nuts and bolts.

INSPECTION AFTER INSTALLATION

- Before starting engine, check oil/fluid levels including engine coolant and engine oil. If there is less than required quantity, fill to the specified level. Refer to [MA-11, "Fluids and Lubricants"](#).
- Use procedure below to check for fuel leakage.
- Turn ignition switch ON (with engine stopped). With fuel pressure applied to fuel piping, check for fuel leakage at connection points.
- Start engine. With engine speed increased, check again for fuel leakage at connection points.
- Run engine to check for unusual noise and vibration.

NOTE:

ENGINE ASSEMBLY

< UNIT REMOVAL AND INSTALLATION >

If hydraulic pressure inside timing chain tensioner drops after removal and installation, slack in the guide may generate a pounding noise during and just after engine start. However, this is normal. Noise will stop after hydraulic pressure rises.

- Warm up engine thoroughly to make sure there is no leakage of fuel, exhaust gas, or any oils/fluids including engine oil and engine coolant.
- Bleed air from passages in lines and hoses, such as in cooling system.
- After cooling down engine, again check oil/fluid levels including engine oil and engine coolant. Refill to specified level, if necessary.
- Summary of the inspection items:

Item		Before starting engine	Engine running	After engine stopped
Engine coolant		Level	Leakage	Level
Engine oil		Level	Leakage	Level
Transmission/ transaxle fluid	A/T and CVT Models	Leakage	Level/Leakage	Leakage
	M/T Models	Level/Leakage	Leakage	Level/Leakage
Other oils and fluids*		Level	Leakage	Level
Fuel		Leakage	Leakage	Leakage
Exhaust gas		—	Leakage	—

*Power steering fluid, brake fluid, etc.

CYLINDER BLOCK

< UNIT DISASSEMBLY AND ASSEMBLY >

UNIT DISASSEMBLY AND ASSEMBLY

CYLINDER BLOCK

Exploded View

INFOID:000000011557867

A

EM

C

D

E

F

G

H

I

J

K

L

M

N

O

P

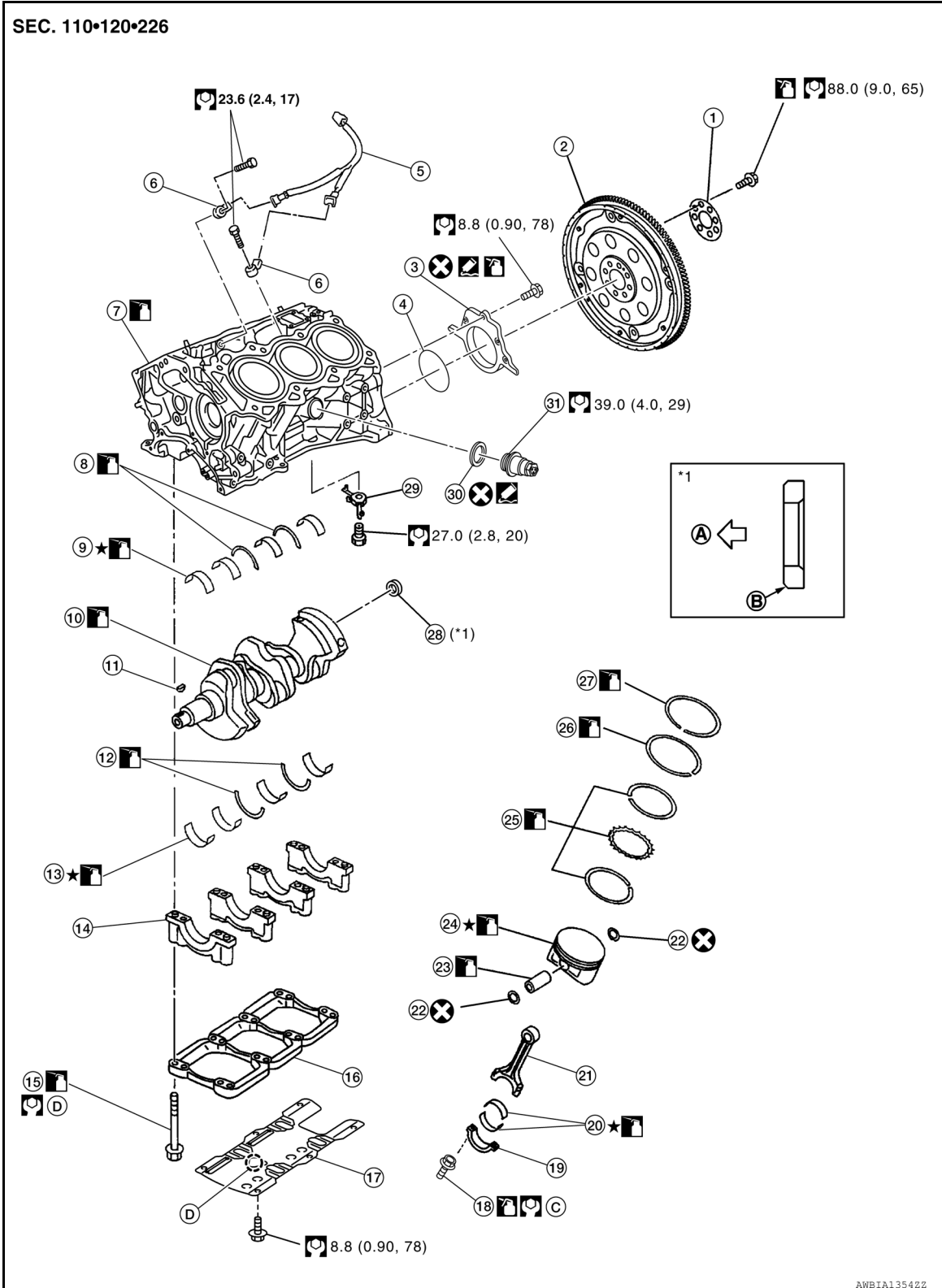

AWBIA13542Z

CYLINDER BLOCK

< UNIT DISASSEMBLY AND ASSEMBLY >

- | | | |
|--|----------------------------|----------------------------|
| 1. Reinforcement plate | 2. Drive plate | 3. Rear oil seal retainer |
| 4. Rear oil seal | 5. Sub harness | 6. Knock sensor |
| 7. Cylinder block | 8. Thrust bearing (upper) | 9. Main bearing (upper) |
| 10. Crankshaft | 11. Crankshaft key | 12. Thrust bearing (lower) |
| 13. Main bearing (lower) | 14. Main bearing cap | 15. Main bearing cap bolt |
| 16. Main bearing beam | 17. Baffle plate | 18. Connecting rod bolt |
| 19. Connecting rod bearing cap | 20. Connecting rod bearing | 21. Connecting rod |
| 22. Snap ring | 23. Piston pin | 24. Piston |
| 25. Oil ring | 26. Second ring | 27. Top ring |
| 28. Pilot converter | 29. Oil jet | 30. Gasket (for Canada) |
| 31. Cylinder block heater (for Canada) | A. Crankshaft side | B. Chamfered |
| C. Refer to INSTALLATION | D. Front mark | |

Disassembly and Assembly

INFOID:000000011557868

CAUTION:

- Apply new engine oil to parts as marked in illustrations before installation.
- Place removed parts such as bearings and bearing caps in their proper order and direction.
- When installing the connecting rod nuts and main bearing cap bolts, apply new engine oil to the threads and mating surfaces
- Do not allow any magnetic materials to contact the signal plate teeth on the drive plate.

DISASSEMBLY

1. Remove the engine assembly. Refer to [EM-104, "FWD : Removal and Installation"](#) (FWD) or [EM-109, "AWD : Removal and Installation"](#) (AWD).
2. Remove the drive plate. Refer to [EM-113, "Exploded View"](#).
3. Remove pilot converter using suitable tool (A).

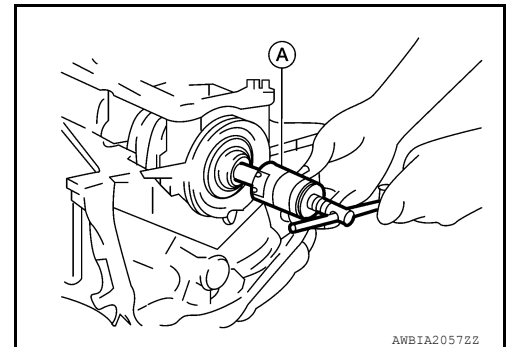

4. Cut away liquid gasket and remove rear oil seal retainer using suitable tool (A). Refer to [EM-5, "Precaution for Liquid Gasket"](#).

Tool number : KV10111100 (J-37228)

CAUTION:

- Be careful not to damage mounting surface.
- If rear oil seal retainer is removed, replace it with a new one.

NOTE:

Rear oil seal and retainer form a single part and are replaced as an assembly.

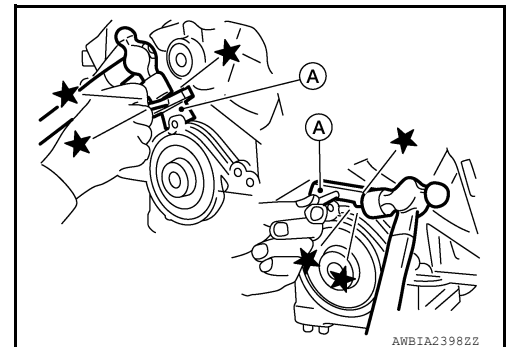

CYLINDER BLOCK

< UNIT DISASSEMBLY AND ASSEMBLY >

5. Install the engine on engine stand (A). Any commercially available engine stand (A) can be used.

CAUTION:

- Use an engine stand (A) that has a load capacity [approximately 240kg (529 lb) or more] large enough for supporting the engine weight.
- Before removing the hanging chains, make sure the engine stand (A) is stable and there is no risk of overturning.

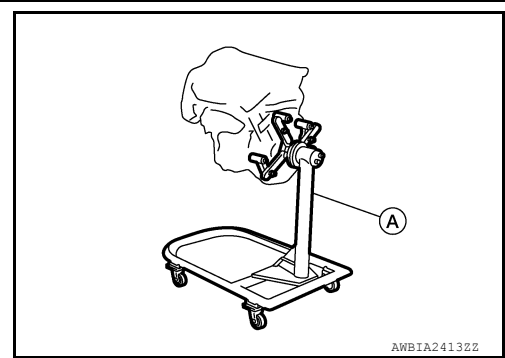

6. Remove the knock sensor.

CAUTION:

Carefully handle sensor to avoid shocking it.

7. Drain engine coolant. Refer to [CO-9. "Changing Engine Coolant"](#).
8. Drain engine oil. Refer to [LU-9. "Changing Engine Oil"](#).
9. Remove the upper oil pan. Refer to [EM-39. "Removal and Installation \(Upper Oil Pan\)"](#).
10. Remove the crankshaft pulley.
 - Use a suitable tool to prevent the crankshaft from turning.
11. Remove the timing chain. Refer to [EM-65. "Removal and Installation"](#).
12. Remove the cylinder head. Refer to [EM-91. "Removal and Installation"](#).

13. Remove the piston and connecting rod assemblies.

- a. Position the crankshaft pin corresponding to the connecting rod to be removed onto the bottom dead center.
- b. Remove the connecting rod cap.
- c. Using a suitable tool (A), push the piston and connecting rod assembly out to the cylinder head side.
 - Before removing the piston and connecting rod assembly, check the connecting rod side clearance. Refer to [EM-146. "Connecting Rod Bearing"](#).

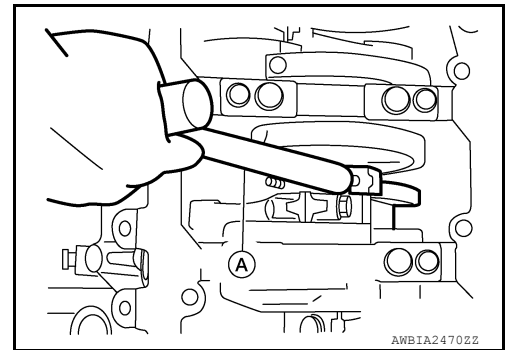

14. Remove the connecting rod bearings.

CAUTION:

- When removing the connecting rod side bearings, note the installation position. Keep them in the correct order.

15. Remove the piston rings from the piston.

- Use a piston ring expander (A).

CAUTION:

- When removing the piston rings, be careful not to damage the piston. Do not expand the rings excessively.
 - Be careful to mark the rings if they are to be reused so they are installed in their original position.
- Before removing the piston rings, check the piston ring side clearance. Refer to [EM-124. "Inspection"](#).

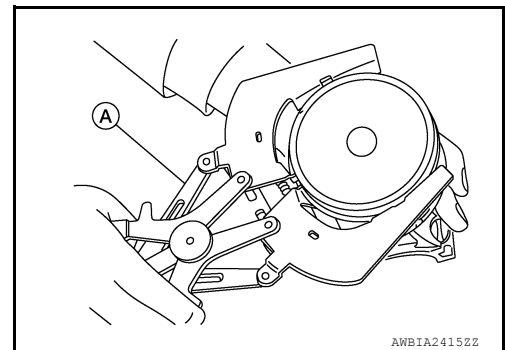

CYLINDER BLOCK

< UNIT DISASSEMBLY AND ASSEMBLY >

16. Remove the piston from the connecting rod as follows.

- a. Using a suitable tool (A), remove the snap ring.

CAUTION:

Do not reuse snap rings, always replace with new ones.

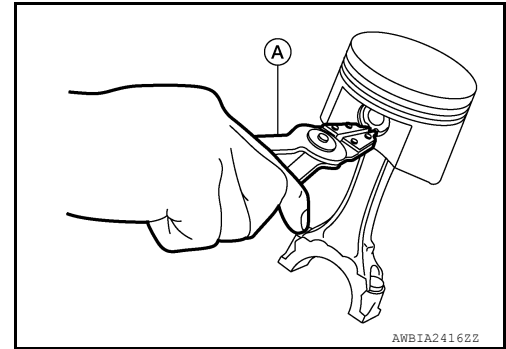

- b. Heat the pistons to 60° - 70°C (140° - 158°F) utilizing suitable tool (A).

WARNING:

Pistons contain heat. When working, wear protective equipment to avoid getting burned.

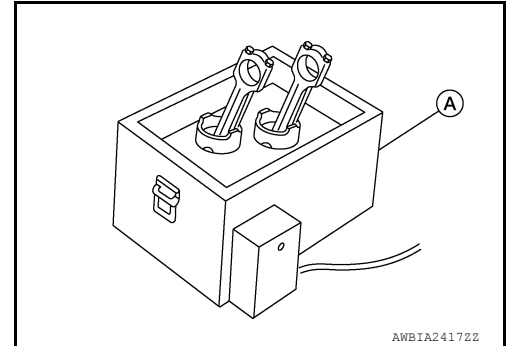

- c. Push out the piston pin with a suitable tool with an outer diameter of approximately 20 mm (0.8 in).

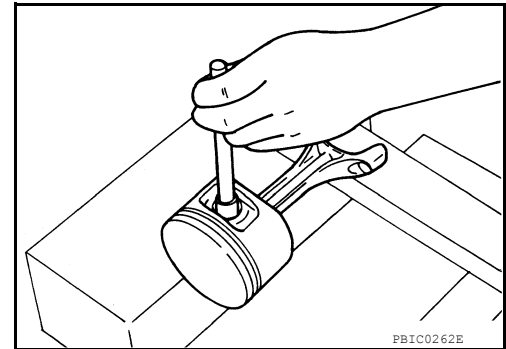

17. Remove the baffle plate from the main bearing beam.

18. Loosen the bolts in the reverse order shown and remove the main bearing beam, bearing caps and crankshaft.

- Before loosening the main bearing cap bolts, measure the crankshaft side clearance.

Refer to [EM-124. "Inspection"](#).

← : Engine front

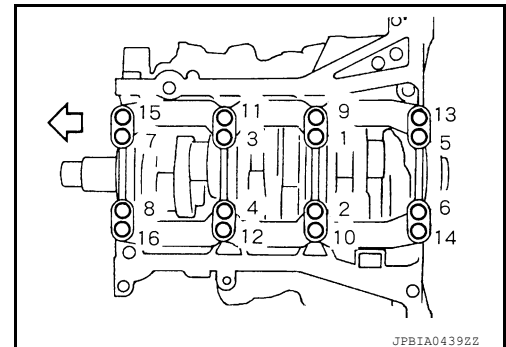

CYLINDER BLOCK

< UNIT DISASSEMBLY AND ASSEMBLY >

19. Remove the oil jets (A) and dowel pins.

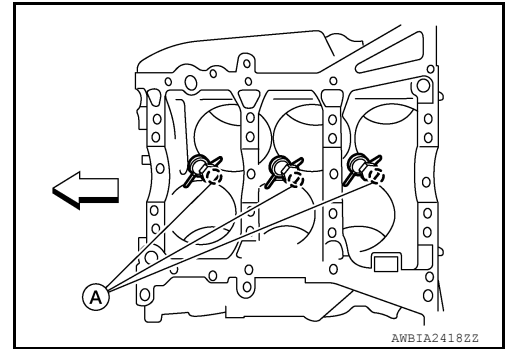

20. Remove the main bearings and thrust bearings from the cylinder block and main bearing caps.

- When removing them, note the direction and position. Keep them in the correct order for installation.

21. Remove the water drain plug (A), connector bolt (D), water drain plug (C) and water drain plug O-ring (B) on the cylinder block.

CAUTION:

Do not reuse water drain plug O-ring (B)

NOTE:

For Canada, connector bolt (D) is a block heater, not a water drain plug.

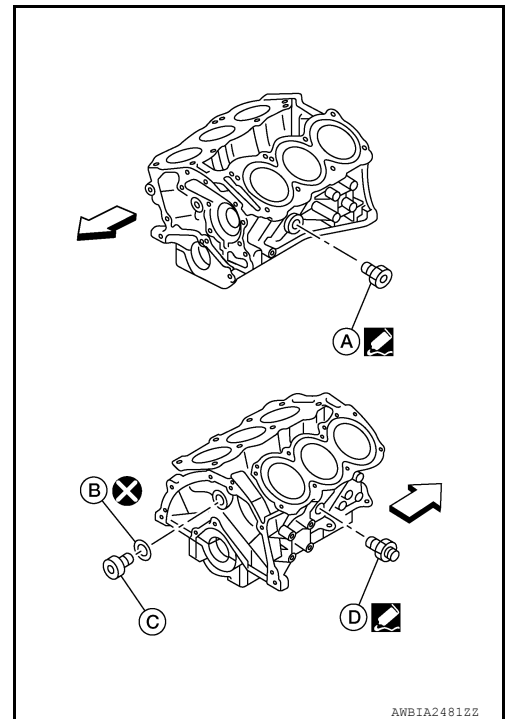

ASSEMBLY

1. Blow out the coolant and oil passages and cylinder bore to remove any foreign materials.

CAUTION:

Use goggles to protect your eyes.

CYLINDER BLOCK

< UNIT DISASSEMBLY AND ASSEMBLY >

2. Install the cylinder block drain plugs.
 - Apply sealant to the threads of the water drain plug (A), and connector bolt (D), (if removed).

CAUTION:

Do not reuse water drain plug O-ring (B).

⇐ : Engine front

NOTE:

- For Canada, connector bolt (D) is a block heater, not a water drain plug.
- Use Genuine High Performance Thread Sealant or equivalent. Refer to [GI-22. "Recommended Chemical Products and Sealants"](#).
- Tighten each plug and connector bolt to specifications.

Water drain plug (B) (except Canada) : 62.0 N·m (6.3 kg-m, 46 ft-lb)

Block heater (B) (Canada) : 39.0 N·m (4.0 kg-m, 29 ft-lb)

Connector Bolt (C) : 27.0 N·m (2.8 kg-m, 20 ft-lb)

Water drain plug (D) : 78.0 N·m (8.0 kg-m, 58 ft-lb)

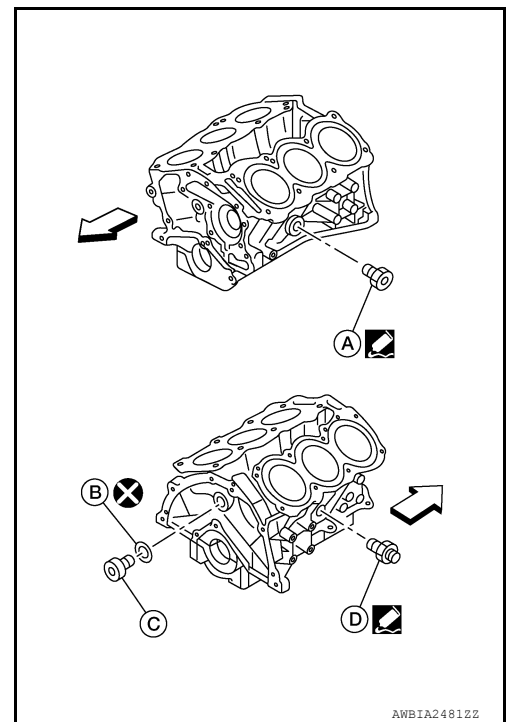

3. Install the oil jets (A).
 - Insert the oil jet dowel pin into the cylinder block dowel pin hole, and tighten the bolts.

⇐ : Engine front

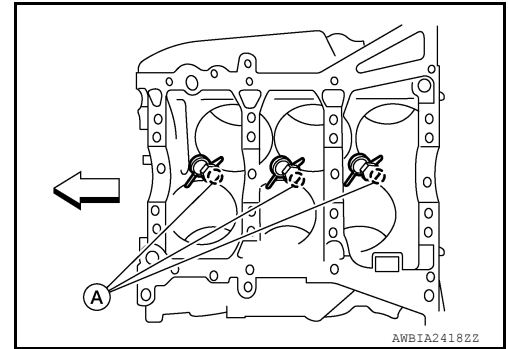

4. Install the main bearings and the thrust bearings (C).
 - a. Remove dust, dirt, and oil on the bearing mating surfaces of the cylinder block and the main bearing cap.
 - b. Install the thrust bearings (C) to both sides (D) of the No. 3 journal housing on the cylinder block (A) and the main bearing cap.
 - Install the thrust bearings (C) with the oil groove (B) facing the crankshaft arm (outside).
 - Install bearing with a projection on one end on cylinder block and bearing with a projection at center on cap. Align each projection with mating notch.

⇐ : Engine front

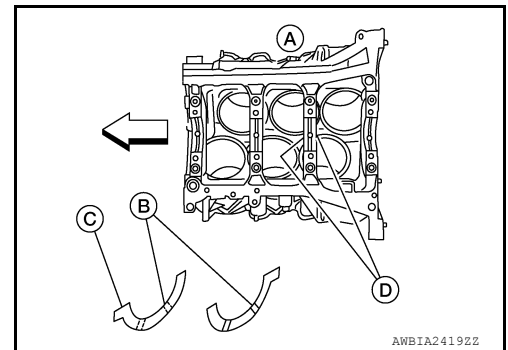

CYLINDER BLOCK

< UNIT DISASSEMBLY AND ASSEMBLY >

5. Set the upper main bearings (A) and the lower main bearings (B) in their proper positions on the cylinder block.
 - Confirm the correct main bearings are used. Refer to [EM-124, "Inspection"](#).

NOTE:

The upper main bearings (A) have an oil groove. The lower main bearings do not have an oil groove.

← : Engine front

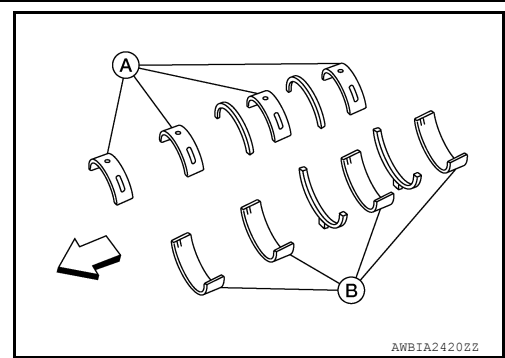

AWBIA2420ZZ

6. Instructions for the reuse of the main bearing cap bolts.
 - A plastic zone tightening method is used for tightening the main bearing cap bolts. Measure (d1) and (d2) as shown.
 - For (d2), select the minimum diameter in the measuring area.
 - If the difference between (d1) and (d2) exceeds the limit, replace the bolts for assembly.

Limit (d1 - d2) : 0.11 mm (0.0043 in)

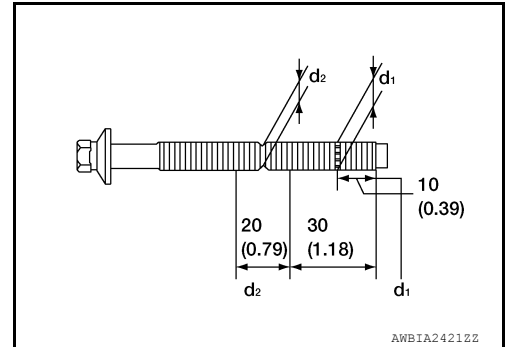

AWBIA2421ZZ

7. After installing the crankshaft, lower main bearings, main bearing caps, main bearing beam, and bearing cap bolts. Tighten the bearing cap bolts in the numerical order as shown.

CAUTION:

Position main bearing caps in accordance with the numerical stamp (A).

← : Engine front

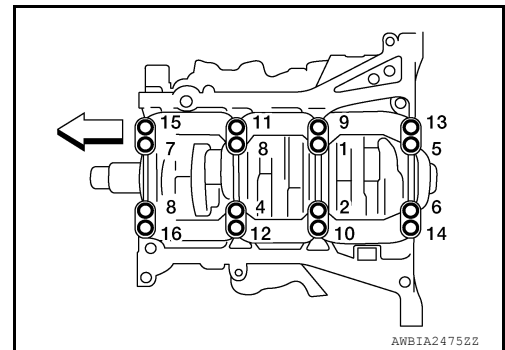

AWBIA2475ZZ

- a. Make sure that the front marks (B) on the main bearing beam faces the front of the engine.
- b. Prior to tightening all the bearing cap bolts, place the bearing beam in its proper position by shifting the crankshaft in the axial position.
- c. After tightening the bearing cap bolts, make sure the crankshaft turns smoothly.
- d. Lubricate the threads and seat surfaces of the bolts with new engine oil.
- e. Tighten the bolts in two stages:

CAUTION:

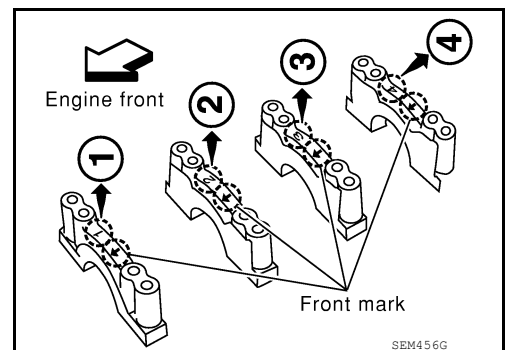

SEM456G

CYLINDER BLOCK

< UNIT DISASSEMBLY AND ASSEMBLY >

Measure the tightening angle in two stages using Tool (A). Do not measure with eyes only, be sure to use Tool (A).

Stage 1 : 32.3 - 38.3 N·m (3.3 - 3.9 kg·m, 24 - 28 ft·lb)

Stage 2 : 90° - 95° degrees clockwise

Tool number : KV10112100 (BT-8653-A)

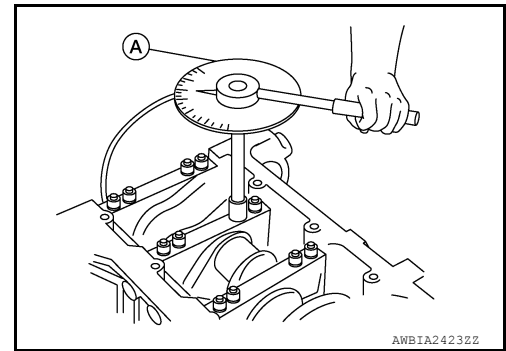

8. Measure crankshaft end play.
- If beyond the limit, replace the thrust bearing with a new one. Refer to [EM-142, "Cylinder Block"](#).

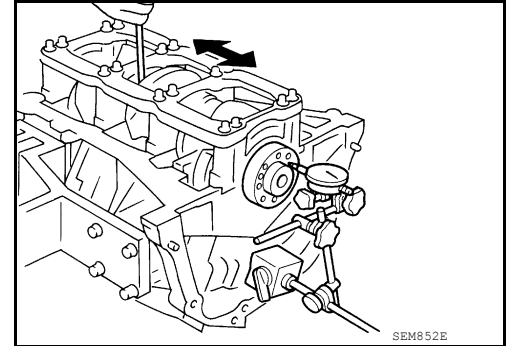

9. Install the piston to the connecting rod.
- a. Using suitable snap ring pliers, install the snap ring fully into the pin-groove of the piston rear side.

CAUTION:

Do not reuse snap rings.

- (A) : Piston front mark
(B) : Oil hole
(C) : Connecting rod front mark
(D) : Cylinder No.

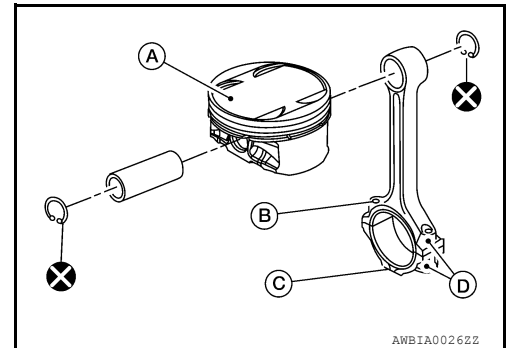

- b. Install the piston to the connecting rod.
- Heat the piston using suitable tool (A) until the piston pin can be pushed in by hand without excess force [approximately 60 - 70°C (140 - 158°F)]. From the front to the rear, insert the piston pin into the piston and through the connecting rod.

WARNING:

Pistons contain heat. When working, wear protective equipment to avoid getting burned.

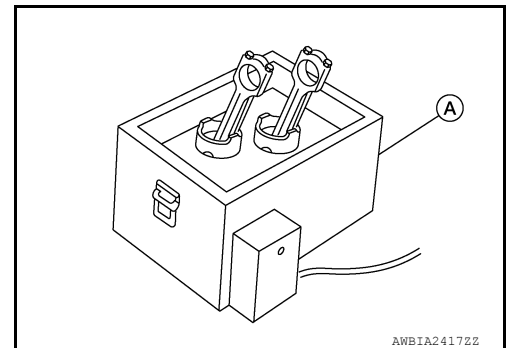

CYLINDER BLOCK

< UNIT DISASSEMBLY AND ASSEMBLY >

- Assemble so that the piston front mark (B) on the crown and the oil hole (C), connecting rod front mark (D) and Cylinder No. (E) on the connecting rod are positioned as shown.

← : Engine front

(A) : Piston grade number

(F) : Pin grade number

(G) : Crown I.D. code

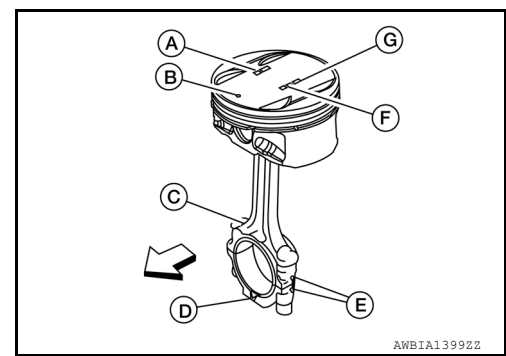

- c. Install the snap ring (A) into the front of the piston pin-groove.
- After installing, check that the connecting rod pivots smoothly on the pin.

CAUTION:

Do not reuse snap rings, always replace with new ones.

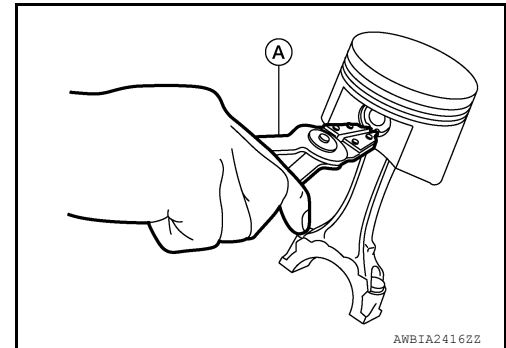

10. Using a piston ring expander, install the piston rings.

(A) : Top ring

(B) : Second ring

CAUTION:

- Be careful not to damage the piston.
- When the piston rings are not replaced, remount the rings in their original positions.
- When replacing the piston rings, those without stamped surface (A) can be mounted either side up.
- Install the second ring with the stamped surface (B) facing upward. If the ring is not stamped it can face in either direction.

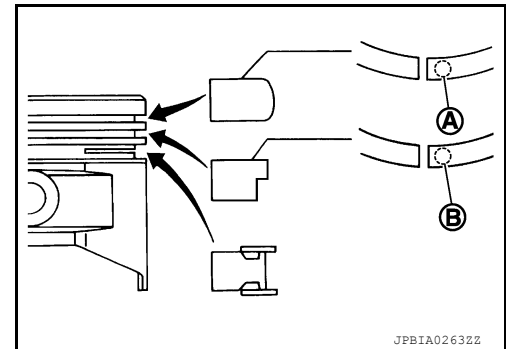

- Position each ring with the gap as shown, referring to the piston front mark.

A. : Top ring gap

B. : Front mark

C. : Oil ring upper or lower rail gap

D. : Second ring and oil ring spacer gap

E. : Oil ring upper or lower rail gap

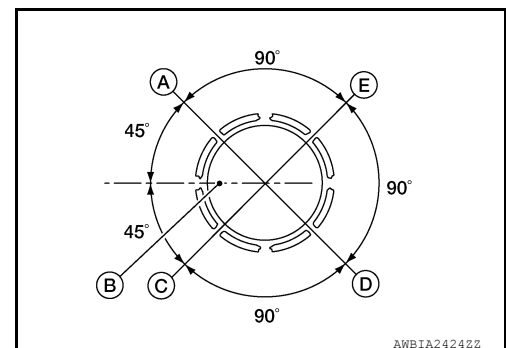

A
EM
C
D
E
F
G
H
I
J
K
L
M
N
O
P

CYLINDER BLOCK

< UNIT DISASSEMBLY AND ASSEMBLY >

11. Install the connecting rod bearings (A) to the connecting rod and the connecting rod cap (B).
- When installing the connecting rod bearings (A), apply engine oil to the bearing surface (crankshaft side). Do not apply oil to the back surface (connecting rod and cap side), but thoroughly clean it.
 - When installing, align the connecting rod bearing (A) protrusion with the notch of the connecting rod to install.
 - Check that the oil holes on the connecting rod (B) and on the corresponding bearing (A) are aligned.

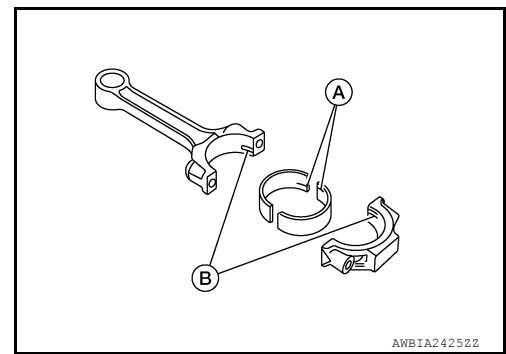

12. Install the piston and connecting rod assembly into the corresponding cylinder.
- Position the crankshaft pin corresponding to the connecting rod to be installed onto the bottom dead center.
 - Apply engine oil sufficiently to the cylinder bore, piston, and crankshaft pin.
 - Match the cylinder position with the cylinder No. (B) on the connecting rod to install.
 - Install the piston with the piston front mark (A) on the crown facing the front of the engine (↔) using a suitable tool.

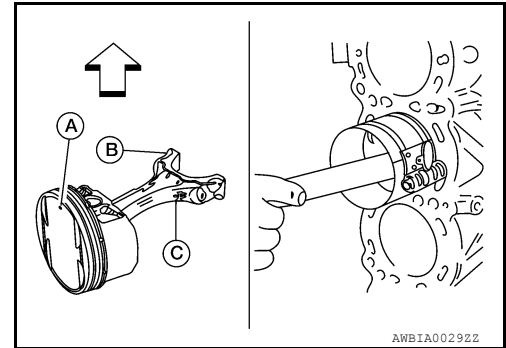

(C) : Oil hole

CAUTION:

Be careful not to damage the crankshaft pin and cylinder wall, resulting from interference of the connecting rod big end.

13. Install the connecting rod cap.
- Observing the sample codes (A), match the stamped cylinder number marks (F) on the connecting rod with those on the cylinder cap for installation.
 - Install the piston connecting rod assembly and cap so that the front mark on the cap and piston are facing the front of the engine.
 - **Lubricate the threads and seat surfaces with new engine oil.**

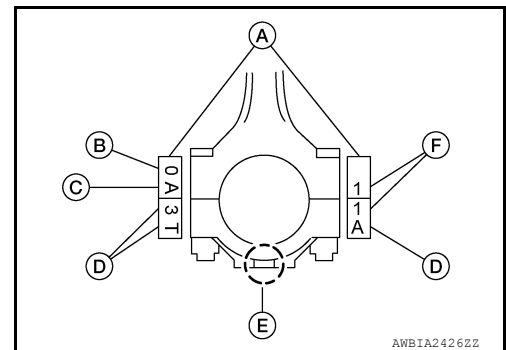

(B). : Small end diameter grade

(C). : Weight grade

(D). : Management code

(E). : Front mark

14. Check the connecting rod cap bolts before reusing, then install in their original position in the connecting rod. The bolts should screw in smoothly by hand.
- Measure the outer diameter of the connecting rod cap bolt as shown.

Outer diameter (d) of the connecting rod bolt

Standard : 7.90 - 8.00 mm (0.3110 - 0.3150 in)

Limit : 7.75 mm (0.3051 in)

A. : 19 mm (0.75 in)

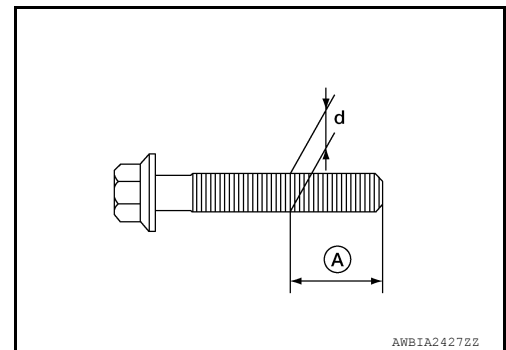

15. Tighten the connecting rod nuts in two stages using Tool:

CYLINDER BLOCK

< UNIT DISASSEMBLY AND ASSEMBLY >

Stage 1 : 19 - 21 N·m (1.9 - 2.1 kg-m, 14 - 15 ft-lb)

Stage 2 : 90° - 95° degrees clockwise

CAUTION:

Always use either an angle wrench or protractor. Avoid tightening based on visual check alone.

Tool number : KV10112100 (BT-8653-A)

- Apply engine oil to the threads and seats of the connecting rod bolts and nuts.
- After tightening the nuts, make sure that the crankshaft rotates smoothly.
- Check the connecting rod side clearance. If beyond the limit, replace the connecting rod and/or crankshaft. Refer to [EM-142. "Cylinder Block"](#).

16. Install the baffle plate to the main bearing beam.

17. Install the knock sensor (A).

- Make sure that there is no foreign material on the cylinder block mating surface and the back surface of the knock sensor (A).
- Install the knock sensor (A) with the connector facing the rear of the engine.
- Do not tighten the bolts while holding the connector.
- Make sure that the knock sensor (A) does not interfere with other parts.

⇐ : Engine front

CAUTION:

If any impact by dropping occurs to the knock sensor (A), replace it with new one.

18. Install the cylinder head. Refer to [EM-91. "Removal and Installation"](#).

19. Install the timing chain. Refer to [EM-65. "Removal and Installation"](#).

20. Install the oil pan. Refer to [EM-38. "Removal and Installation \(Lower Oil Pan\)"](#) and [EM-39. "Removal and Installation \(Upper Oil Pan\)"](#).

21. Remove the engine from the stand.

22. Install the pilot converter with its chamfer facing crankshaft as shown.

⇐ : Crankshaft side

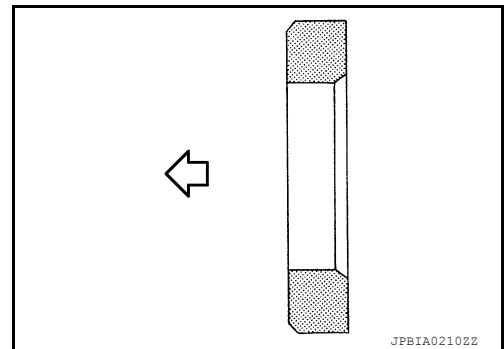
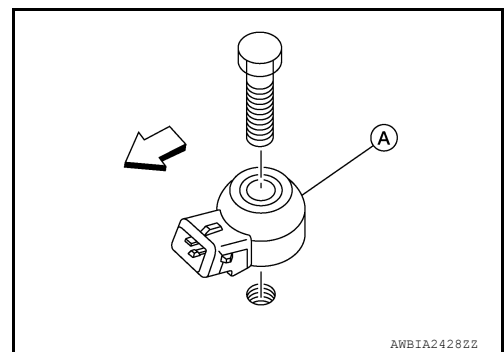
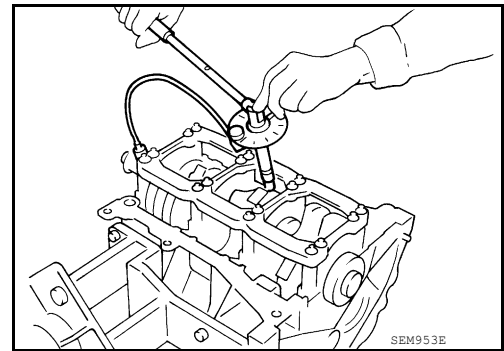

A
EM
C
D
E
F
G
H
I
J
K
L
M
N
O
P

CYLINDER BLOCK

< UNIT DISASSEMBLY AND ASSEMBLY >

23. Install the rear oil seal using Tool (A).

Tool number : — (J-47128)

- Loosen the wing nut (B) on the end of the Tool (A).
- Insert the arbor (D) into the crankshaft pilot hole until the outer lip (C) of the Tool (A) covers the edge of the crankshaft sealing surface.
- Tighten the wing nut (B) to secure the Tool (A) to the crankshaft.

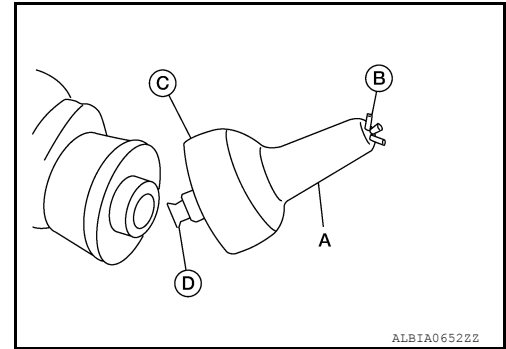

- Apply sealant to rear oil seal retainer as shown. Use **Genuine Silicone RTV Sealant, or equivalent**. Refer to [GI-22, "Recommended Chemical Products and Sealants"](#).

CAUTION:

- Installation should be done within 5 minutes after applying liquid gasket.
- Do not fill the engine with oil for at least 30 minutes after the components are installed to allow the sealant to cure.

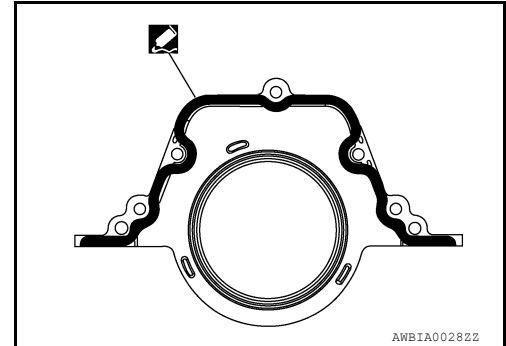

- Lubricate the sealing surface of the new rear main seal with new engine oil.
- Slide the new rear main seal (1) over the Tool (A) and onto the crankshaft.
- Loosen the wing nut and push the threaded rod into the handle to remove the Tool (A).
- Tighten the rear oil seal retainer bolts to specification. Refer to [EM-89, "Removal and Installation of Rear Oil Seal"](#).

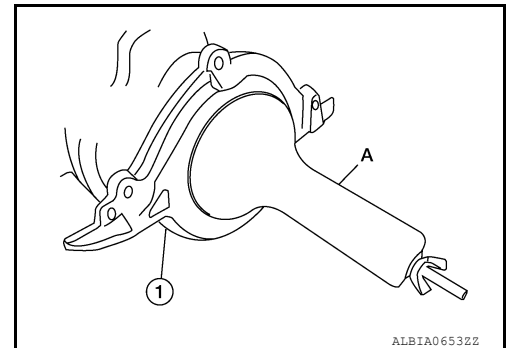

24. Install the drive plate. Refer to [EM-113, "Exploded View"](#).

25. Install the engine assembly into the vehicle. Refer to [EM-104, "FWD : Removal and Installation"](#) (FWD) or [EM-109, "AWD : Removal and Installation"](#) (AWD).

Inspection

INFOID:000000011557869

PISTON AND PISTON PIN CLEARANCE

Inner Diameter of Piston Pin Hole

- Measure the inner diameter of piston pin hole (dp). Refer to [EM-142, "Cylinder Block"](#).

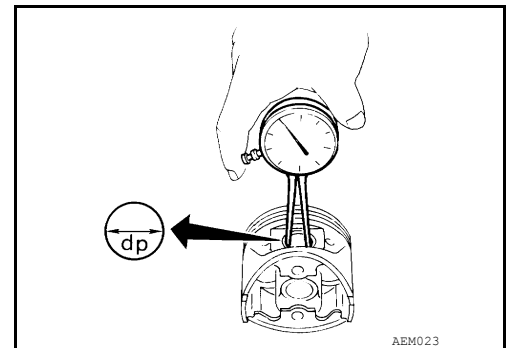

Outer Diameter of Piston Pin

CYLINDER BLOCK

< UNIT DISASSEMBLY AND ASSEMBLY >

- Measure outer diameter of piston pin (Dp) using suitable tool (A). Refer to [EM-124, "Inspection"](#).

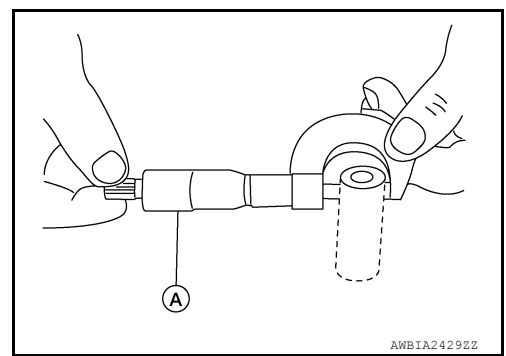

A

EM

C

D

- ⇐ : Engine front
- (A) : Piston Grade No.
- (B) : Piston front mark
- (C) : Oil hole
- (D) : Connecting rod front mark
- (E) : Cylinder No.
- (F) : Pin Grade No.

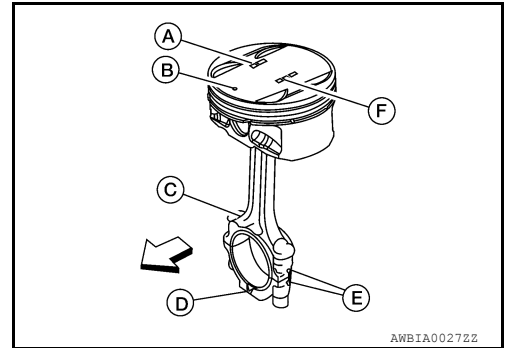

E

F

G

H

Piston and Piston Pin Interference Fit
Standard Interference Fit = (Dp) – (dp)

Standard : 0.002 – 0.010 mm (0.0001 – 0.0004 in)

- If clearance exceeds specification, replace either or both of piston/piston pin assembly and connecting rod assembly with reference to specification of each part.

PISTON RING SIDE CLEARANCE

- Measure side clearance of piston ring and piston ring groove with suitable tool (B).
- If out of specification, replace piston ring assembly (D). If clearance exceeds maximum limit with new rings, replace piston. Refer to [EM-142, "Cylinder Block"](#).

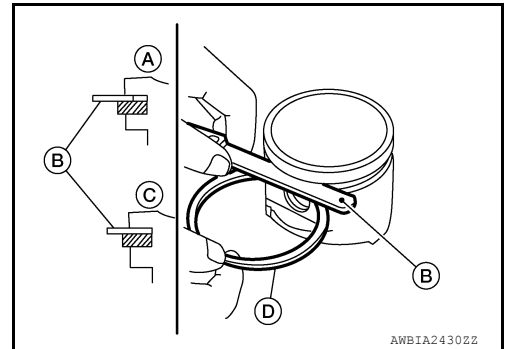

I

J

K

L

M

- A. : NG
- C. : OK

PISTON RING END GAP

- Insert piston ring (C) until it is in the middle of the cylinder bore and measure the end gap using suitable tool (A).
- If out of specification, replace piston ring (C). Refer to [EM-142, "Cylinder Block"](#).

- B. : Piston Press Fit

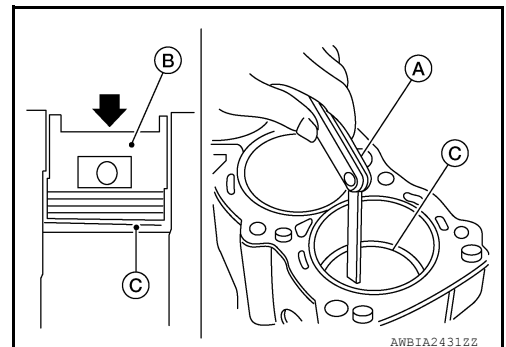

N

O

P

CONNECTING ROD BEND AND TORSION

CYLINDER BLOCK

< UNIT DISASSEMBLY AND ASSEMBLY >

- Use suitable tool (A) to measure bend (B) and torsion (B).
- If bend (B) or torsion (B) exceeds the limit, replace connecting rod assembly. Refer to [EM-146. "Connecting Rod Bearing"](#).

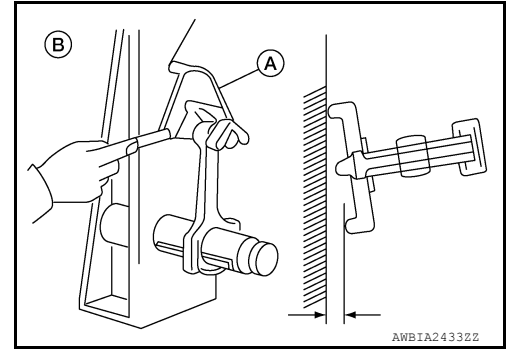

CONNECTING ROD BEARING HOUSING DIAMETER (BIG END)

- Install the connecting rod cap without the connecting rod bearing installed. After tightening the connecting rod nut to the specified torque, measure the connecting rod bearing housing big end inner diameter using a suitable tool (A). Refer to [EM-146. "Connecting Rod Bearing"](#).

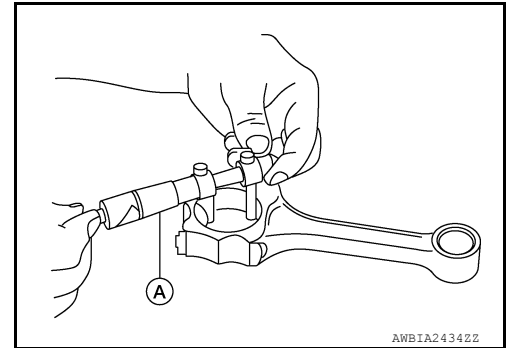

CONNECTING ROD BUSHING OIL CLEARANCE (SMALL END)

Inner Diameter of Connecting Rod (Small End)

- Measure inner diameter of piston pin bushing using a suitable tool (A). Refer to [EM-146. "Connecting Rod Bearing"](#).

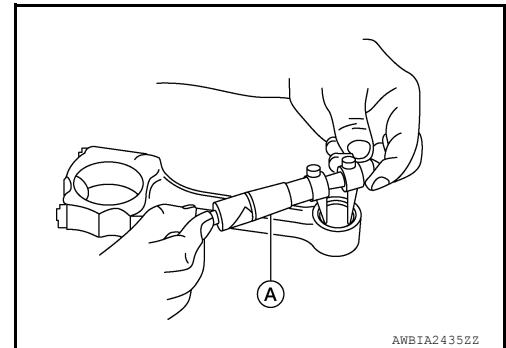

Outer Diameter of Piston Pin

- Measure outer diameter of piston pin using suitable tool (A). Refer to [EM-142. "Cylinder Block"](#).

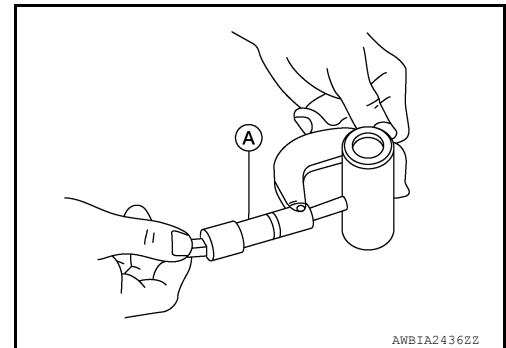

Connecting Rod Bushing Oil Clearance (Small End)

CYLINDER BLOCK

< UNIT DISASSEMBLY AND ASSEMBLY >

(Connecting rod small end oil clearance) = (Inner diameter of connecting rod small end) – (Outer diameter of piston pin). Refer to [EM-142, "Cylinder Block"](#).

- If the measured value exceeds the standard, replace the connecting rod assembly and/or piston and piston pin assembly.
- If replacing the piston and piston pin assembly, use the Table for Selective Fitting for Piston to select the piston corresponding to the applicable bore grade of the cylinder block to be used. Follow the "PISTON-TO-CYLINDER BORE CLEARANCE" procedure.

- A. : Sample codes
- B. : Small end diameter grade
- C. : Weight grade
- D. : Management code
- E. : Front mark
- F. : Cylinder number

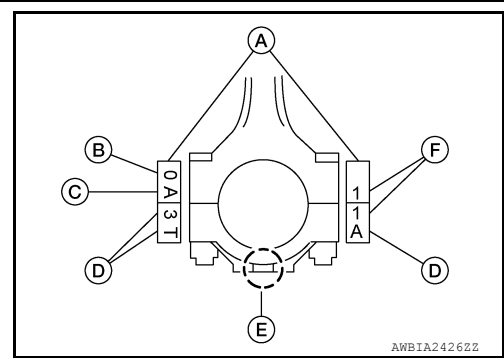

Factory installed parts grading:

- ↔: : Engine front
- (A) : Piston Grade No.
- (B) : Piston front mark
- (C) : Oil hole
- (D) : Connecting rod front mark
- (E) : Cylinder No.
- (F) : Pin Grade No.
- (G) : Crown I.D. code

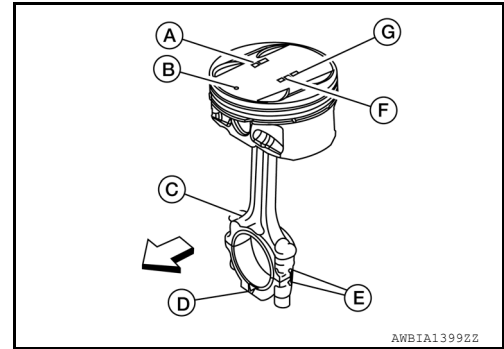

Service parts apply only to grade 0.

Unit: mm (in)

Grade	0	1
Connecting rod small end inner diameter	22.000 - 22.006 (0.8661 - 0.8664)	22.006 - 22.012 (0.8664 - 0.8666)
Piston pin outer diameter	21.989 - 21.995 (0.8657 - 0.8659)	21.995 - 22.001 (0.8659 - 0.8662)
Piston pin hole diameter	21.993 - 21.999 (0.8659 - 0.8661)	21.999 - 22.005 (0.8661 - 0.8663)

CYLINDER BLOCK DISTORTION

- Using a scraper, remove any old gasket material on the cylinder block surface and remove any oil, scale, carbon, or other contamination.

CAUTION:

Be careful not to allow gasket flakes to enter the oil or coolant passages.

- Using suitable tools (A/B), measure the distortion on the block upper face at different points in six directions. Refer to [EM-142, "Cylinder Block"](#).
- If out of specification, resurface the cylinder block. The allowable amount of resurfacing is dependent on the amount of any cylinder head resurfacing. The resurfacing limit is [amount of cylinder head resurfacing] + [amount of cylinder head resurfacing] = 0.2 mm (0.008 in).

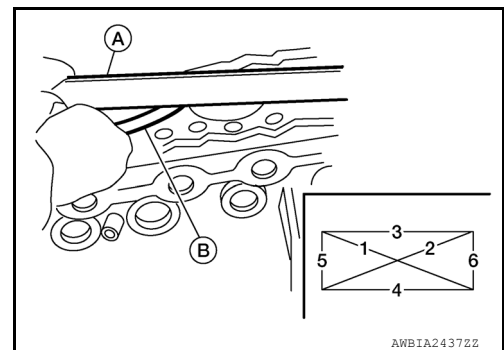

**Cylinder block height : 214.95 - 215.05 mm
(8.4626 - 8.4665 in)**

CYLINDER BLOCK

< UNIT DISASSEMBLY AND ASSEMBLY >

INNER DIAMETER OF MAIN BEARING HOUSING

- Install the main bearing caps with the main bearings removed, and tighten the bolts to the specified torque.
- Using a bore gauge, measure the inner diameter of the main bearing housing (A). Refer to [EM-142, "Cylinder Block"](#).
- If out of the standard, replace the cylinder block and main bearing caps as an assembly.

NOTE:

These components cannot be replaced as a single unit, because they were processed together.

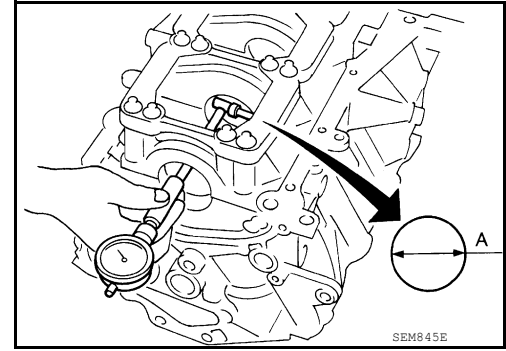

PISTON-TO-CYLINDER BORE CLEARANCE

1. Using a bore gauge, measure cylinder bore for wear, out-of-round and taper at (A), (B) and (C). The X axis is in the longitudinal direction of the engine.

Cylinder bore inner diameter

Grade No.	Standard inner diameter	Wear limit
No. 1	95.500 - 95.510 mm (3.7598 - 3.7602 in)	0.20 mm (0.0079 in)
No. 2	95.510 - 95.520 mm (3.7602 - 3.7606 in)	
No. 3	95.520 - 95.530 mm (3.7606 - 3.7610 in)	

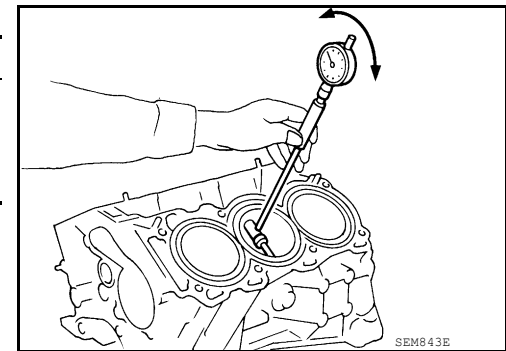

If it exceeds the limit, rebore all cylinders. Replace cylinder block if necessary. Refer to [EM-142, "Cylinder Block"](#).

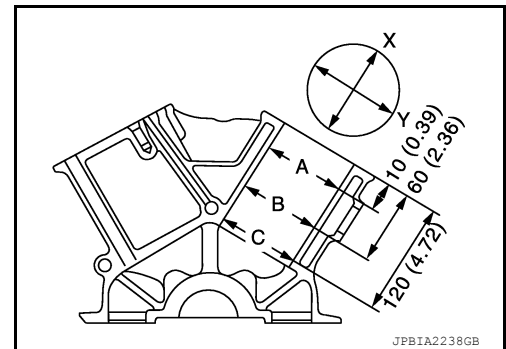

2. Check for scratches and seizure. If seizure is found, hone it.
 - If both cylinder block and piston are replaced with new ones, select piston of the same grade number punched on cylinder block rear position. These numbers are punched in either Arabic or Roman numerals.

- A. : Cylinder bore grade
- B. : Small end diameter grade
- C. : Management code
- ⇐ : Engine front

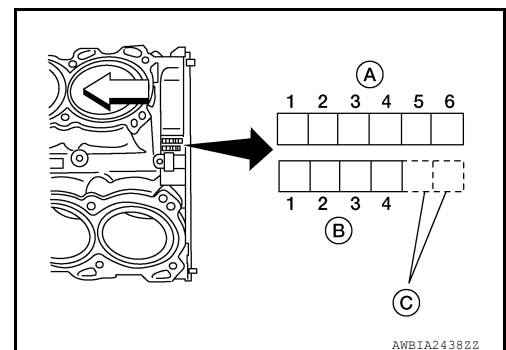

CYLINDER BLOCK

< UNIT DISASSEMBLY AND ASSEMBLY >

3. Measure piston skirt diameter. Refer to [EM-142, "Cylinder Block"](#).

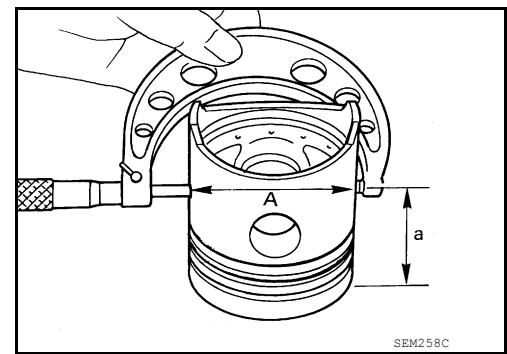

4. Check that piston-to-bore clearance is within specification. Refer to [EM-142, "Cylinder Block"](#).
- The piston-to-bore clearance is measured at the (B) level in the cylinder as shown.

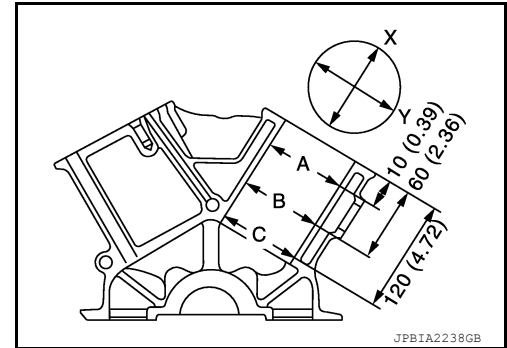

5. Cylinder bore size is determined by adding piston-to-bore clearance to piston diameter (A).

Rebored size calculation : $D = A + B - C$

where,

- (D) : Bored diameter**
- (A) : Piston diameter as measured**
- (B) : Piston-to-bore clearance**
- (C) : Honing allowance 0.02 mm (0.0008 in)**

6. Install main bearing caps, and tighten to the specified torque. Otherwise, cylinder bores may be distorted after boring.
7. Cut cylinder bores.
- When any cylinder needs boring, all other cylinders must also be bored.**
 - Do not cut too much out of cylinder bore at a time. Cut only 0.05 mm (0.0020 in) or so in diameter at a time.**
8. Hone cylinders to obtain specified piston-to-bore clearance.
9. Measure finished cylinder bore for out-of-round and taper.
- Measurement should be done after cylinder bore cools down.**

CRANKSHAFT

1. Check the crankshaft main and pin journals for scoring, wear, or cracks.
2. Measure the journals for taper and out-of-round. Refer to [EM-142, "Cylinder Block"](#).

- Taper : A - B
- Out-of-round : X - Y

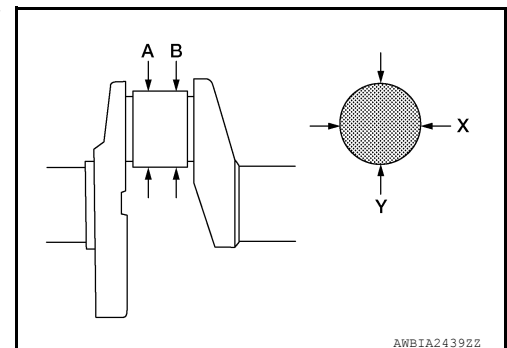

CYLINDER BLOCK

< UNIT DISASSEMBLY AND ASSEMBLY >

3. Measure crankshaft runout.
 - a. Place a V-block on a precise flat table to support the journals on the both ends of the crankshaft.
 - b. Place a dial gauge straight up on the No. 3 journal.
 - c. While rotating the crankshaft, read the movement of the pointer on the dial gauge. Refer to [EM-142, "Cylinder Block"](#).

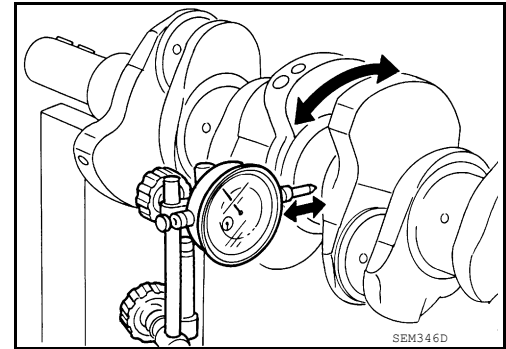

BEARING CLEARANCE

- Use either of the following two methods, however method (A) gives more reliable results and so is the preferred method.

Method A (Using Bore Gauge and Micrometer)

Main Bearing

1. Set the upper main bearings (A) and the lower main bearings (B) in their proper positions on the cylinder block.
 - Confirm the correct main bearings are used. Refer to [EM-124, "Inspection"](#).

NOTE:

The upper main bearings (A) have an oil groove. The lower main bearings do not have an oil groove.

⇐ : Engine front

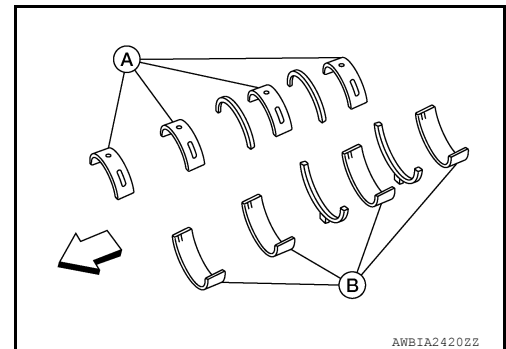

2. Install the main bearing caps and bearing beam to the cylinder block. Tighten all bolts in the numerical order as specified. Refer to [EM-114, "Disassembly and Assembly"](#).
3. Measure the inner diameters (A) of each main bearing as shown.

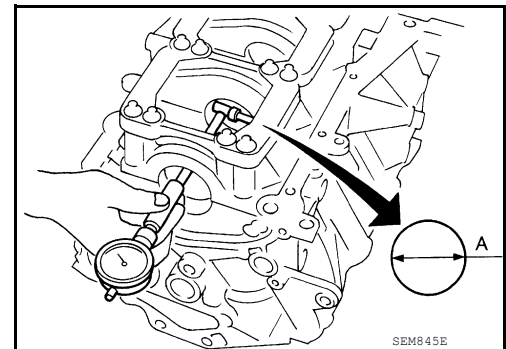

4. Measure the outer diameters (Dm) of each crankshaft main journal as shown.
5. Calculate the main bearing clearance. Refer to [EM-145, "Main Bearing"](#).
 - If it exceeds the limit, replace the bearing.
 - If clearance cannot be adjusted using any standard bearing grade, grind crankshaft journal and use an undersized bearing.

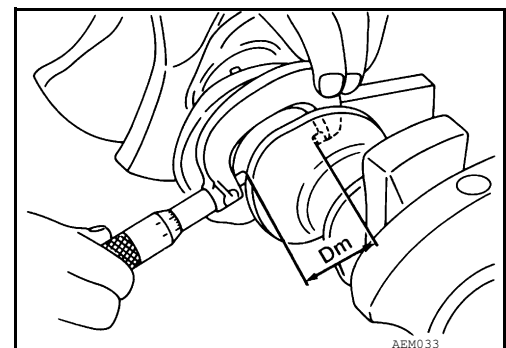

CYLINDER BLOCK

< UNIT DISASSEMBLY AND ASSEMBLY >

- When grinding the crankshaft journal, confirm that the (L) dimension in the fillet role is more than the specified limit. Refer to [EM-142. "Cylinder Block"](#).

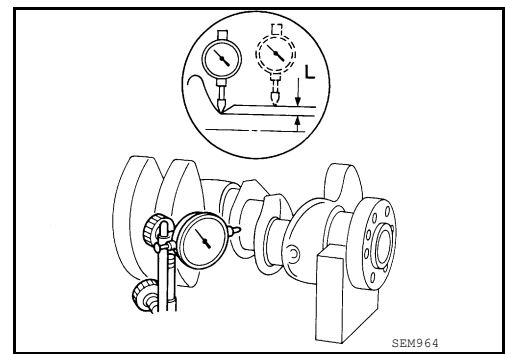

6. If the crankshaft or the cylinder block is replaced with a new one, select thickness of the main bearings as follows:

- a. The grade number of each cylinder block main journal is punched on the respective cylinder block. These numbers are punched in either Arabic or Roman numerals. If measured diameter is out of the grade punched, decide suitable grade from available main bearings.

- A. : Cylinder bore grade
- B. : Small end diameter grade
- C. : Management code
- ⇐ : Engine front

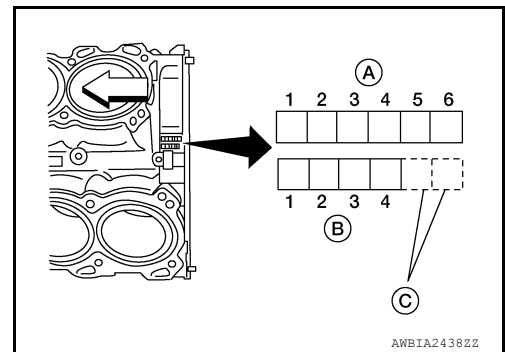

- b. The grade number of each crankshaft main journal is punched on the crankshaft end. These numbers are punched in either Arabic or Roman numerals. If measured diameter is out of grade punched, decide the suitable grade from available main bearings.

- A. : Journal diameter grade
- B. : Identification code
- C. : Pin diameter grade

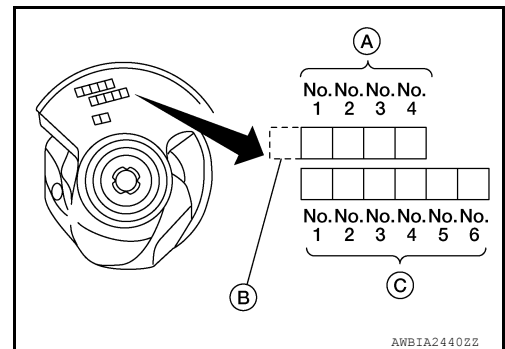

A
EM
C
D
E
F
G
H
I
J
K
L
M
N
O
P

CYLINDER BLOCK

< UNIT DISASSEMBLY AND ASSEMBLY >

c. Select the main bearing suitable thickness according to the following table:

Cylinder block bearing housing inner diameter Unit: mm (in)		Crankshaft main journal diameter Unit: mm (in)		Hole diameter																																			
				Mark																																			
Mark	Axle diameter	A	B	C	D	E	F	G	H	J	K	L	M	N	P	R	S	T	U	V	W	X	Y	4	7														
A	59.975 - 59.974 (2.3612 - 2.3612)	0	0	0	0	1	1	1	1	1	1	1	2	2	2	2	2	2	2	3	3	3	3	3	3	3	3	3	3	3	3	3	3	3	3	3	3		
B	59.974 - 59.973 (2.3612 - 2.3611)	0	0	0	1	1	1	1	1	1	1	2	2	2	2	2	2	2	2	3	3	3	3	3	3	3	3	3	3	3	3	3	3	3	3	3	3	3	
C	59.973 - 59.972 (2.3611 - 2.3611)	0	0	1	1	1	1	1	1	1	2	2	2	2	2	2	2	2	2	3	3	3	3	3	3	3	3	3	3	3	3	3	3	3	3	3	3	3	
D	59.972 - 59.971 (2.3611 - 2.3611)	0	1	1	1	1	1	1	1	2	2	2	2	2	2	2	2	2	2	3	3	3	3	3	3	3	3	3	3	3	3	3	3	3	3	3	3	3	
E	59.971 - 59.970 (2.3611 - 2.3610)	0	1	1	1	1	1	1	2	2	2	2	2	2	2	2	2	2	2	3	3	3	3	3	3	3	3	3	3	3	3	3	3	3	3	3	3	3	3
F	59.970 - 59.969 (2.3610 - 2.3610)	0	1	1	1	1	1	2	2	2	2	2	2	2	2	2	2	2	2	3	3	3	3	3	3	3	3	3	3	3	3	3	3	3	3	3	3	3	3
G	59.969 - 59.968 (2.3610 - 2.3609)	1	1	1	1	2	2	2	2	2	2	2	2	2	2	2	2	2	2	3	3	3	3	3	3	3	3	3	3	3	3	3	3	3	3	3	3	3	3
H	59.968 - 59.967 (2.3609 - 2.3609)	1	1	2	2	2	2	2	2	2	2	2	2	2	2	2	2	2	2	3	3	3	3	3	3	3	3	3	3	3	3	3	3	3	3	3	3	3	3
J	59.967 - 59.966 (2.3609 - 2.3609)	1	2	2	2	2	2	2	2	2	2	2	2	2	2	2	2	2	2	3	3	3	3	3	3	3	3	3	3	3	3	3	3	3	3	3	3	3	3
K	59.966 - 59.965 (2.3909 - 2.3608)	1	2	2	2	2	2	2	2	2	2	2	2	2	2	2	2	2	2	3	3	3	3	3	3	3	3	3	3	3	3	3	3	3	3	3	3	3	3
L	59.965 - 59.964 (2.3608 - 2.3608)	1	2	2	2	2	2	2	2	2	2	2	2	2	2	2	2	2	2	3	3	3	3	3	3	3	3	3	3	3	3	3	3	3	3	3	3	3	3
M	59.964 - 59.963 (2.3608 - 2.3607)	1	2	2	2	2	2	2	2	2	2	2	2	2	2	2	2	2	2	3	3	3	3	3	3	3	3	3	3	3	3	3	3	3	3	3	3	3	3
N	59.963 - 59.962 (2.3607 - 2.3607)	2	2	2	2	2	2	2	2	2	2	2	2	2	2	2	2	2	2	3	3	3	3	3	3	3	3	3	3	3	3	3	3	3	3	3	3	3	3
P	59.962 - 59.961 (2.3607 - 2.3607)	2	2	2	2	2	2	2	2	2	2	2	2	2	2	2	2	2	2	3	3	3	3	3	3	3	3	3	3	3	3	3	3	3	3	3	3	3	3
R	59.961 - 59.960 (2.3607 - 2.3606)	2	2	2	2	2	2	2	2	2	2	2	2	2	2	2	2	2	2	3	3	3	3	3	3	3	3	3	3	3	3	3	3	3	3	3	3	3	3
S	59.960 - 59.959 (2.3606 - 2.3606)	2	2	2	2	2	2	2	2	2	2	2	2	2	2	2	2	2	2	3	3	3	3	3	3	3	3	3	3	3	3	3	3	3	3	3	3	3	3
T	59.959 - 59.958 (2.3606 - 2.3605)	2	2	2	2	2	2	2	2	2	2	2	2	2	2	2	2	2	2	3	3	3	3	3	3	3	3	3	3	3	3	3	3	3	3	3	3	3	3
U	59.958 - 59.957 (2.3605 - 2.3605)	2	2	2	2	2	2	2	2	2	2	2	2	2	2	2	2	2	2	3	3	3	3	3	3	3	3	3	3	3	3	3	3	3	3	3	3	3	3
V	59.957 - 59.956 (2.3605 - 2.3605)	3	3	3	3	3	3	3	3	3	3	3	3	3	3	3	3	3	3	3	3	3	3	3	3	3	3	3	3	3	3	3	3	3	3	3	3	3	3
W	59.956 - 59.955 (2.3605 - 2.3604)	3	3	3	3	3	3	3	3	3	3	3	3	3	3	3	3	3	3	3	3	3	3	3	3	3	3	3	3	3	3	3	3	3	3	3	3	3	3
X	59.955 - 59.954 (2.3604 - 2.3604)	3	3	3	3	3	3	3	3	3	3	3	3	3	3	3	3	3	3	3	3	3	3	3	3	3	3	3	3	3	3	3	3	3	3	3	3	3	3
Y	59.954 - 59.953 (2.3604 - 2.3603)	3	3	3	3	3	3	3	3	3	3	3	3	3	3	3	3	3	3	3	3	3	3	3	3	3	3	3	3	3	3	3	3	3	3	3	3	3	3
4	59.953 - 59.952 (2.3603 - 2.3603)	3	3	3	3	3	3	3	3	3	3	3	3	3	3	3	3	3	3	3	3	3	3	3	3	3	3	3	3	3	3	3	3	3	3	3	3	3	3
7	59.952 - 59.951 (2.3603 - 2.3603)	3	3	3	3	3	3	3	3	3	3	3	3	3	3	3	3	3	3	3	3	3	3	3	3	3	3	3	3	3	3	3	3	3	3	3	3	3	3

PBIC0814E

Connecting Rod Bearing (Big End)

1. Install the connecting rod bearing to the connecting rod and cap.
2. Install the connecting rod cap to the connecting rod. Tighten to specification. Refer to [EM-114, "Disassembly and Assembly"](#).
3. Measure the inner diameter (C) of each connecting rod (big end) using suitable tool (A) as shown.

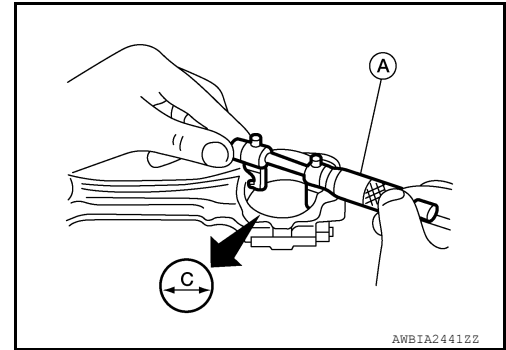

AWBIA2441Z2

CYLINDER BLOCK

< UNIT DISASSEMBLY AND ASSEMBLY >

4. Measure the outer diameter (Dp) of each crankshaft pin journal.
5. Calculate the connecting rod bearing clearance. Refer to [EM-146. "Connecting Rod Bearing"](#).
Connecting rod bearing clearance = (C) - (Dp)
6. If the calculated clearance exceeds the specified limit, replace the bearings.
7. If the clearance cannot be adjusted within the standard of any bearing, grind the crankshaft journal and use undersized bearings.

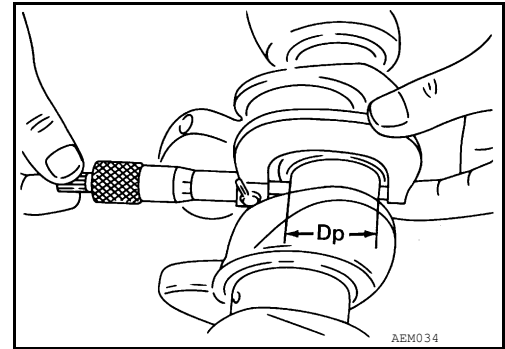

8. If the crankshaft is replaced with a new one, select the connecting rod bearings according to the following table:
Connecting Rod Bearing Grade Number (Identification Color)

Crankshaft pin journal grade number	Connecting rod bearing grade number
0	0 (black)
1	1 (brown)
2	2 (green)

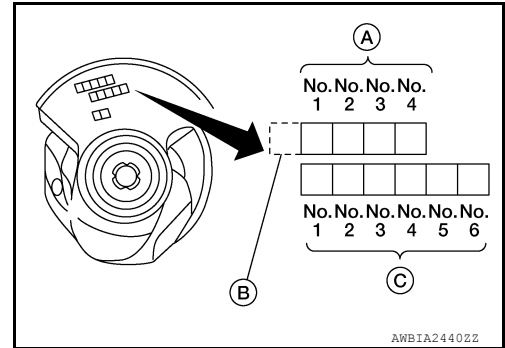

These numbers are punched in either Arabic or Roman numerals.

- A. : Journal diameter grade
- B. : Identification code
- C. : Pin diameter grade

Method B (Using Plastigage)

- Remove oil and dust on the crankshaft pin and the surfaces of each bearing completely.
- Cut a Plastigage slightly shorter than the bearing width, and place it in crankshaft axial direction, avoiding oil holes.
- Install the connecting rod bearings to the connecting rod cap, and tighten the connecting rod nuts to the specified torque.

CAUTION:

Do not rotate the crankshaft.

- Remove the connecting rod cap and bearings, and using the scale on the Plastigage bag, measure the Plastigage width.

NOTE:

The procedure when the measured value exceeds the repair limit is same as that described in "Method A (Using Bore Gauge and Micrometer)".

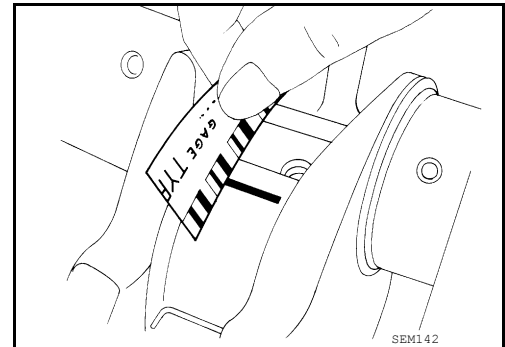

DRIVE PLATE RUNOUT

Use dial gauge to measure the runout (Total Indicator Reading) as shown. Refer to [EM-147. "Drive Plate"](#).

CAUTION:

- The signal plate is built into the drive assembly. Be careful not to damage the signal plate, particularly the teeth.

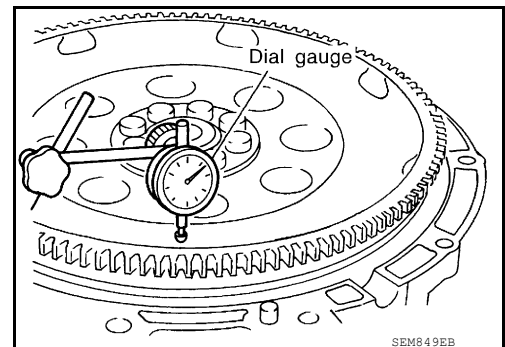

- Check the drive plate and signal plate for deformation or cracks.

CYLINDER BLOCK

< UNIT DISASSEMBLY AND ASSEMBLY >

- **Keep all magnetized objects away from the signal plate, particularly the teeth.**

OIL JET

- Check nozzle for deformation and damage.
- Blow compressed air from nozzle, and check for clogs.
- If it is not operating properly, replace oil jet.

OIL JET RELIEF VALVE

- Using a clean plastic stick, press check valve in oil jet relief valve. Make sure that valve moves smoothly with proper reaction force.
- If it is not operating properly, replace oil jet relief valve.

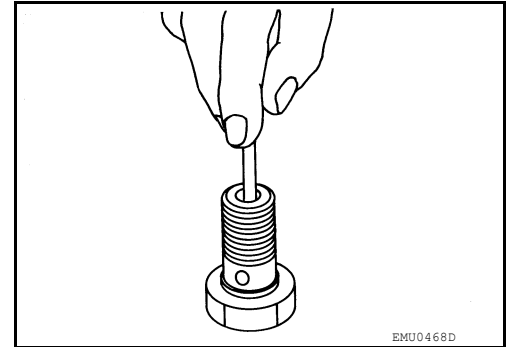

INFOID:000000011557870

Dowel Pin Alignment

REMOVAL

1. Use suitable tool to lock the drive plate and match mark (A) the drive plate before removing the bolts.

CAUTION:

Do not damage the ring gear teeth or the signal plate teeth behind the ring gear.

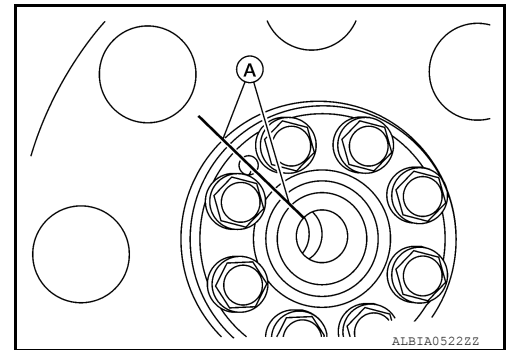

2. Remove drive plate.

- Loosen the drive plate in a diagonal order.

CAUTION:

- **Do not place drive plate with signal plate facing down.**
- **When handling the signal plate, take care not to damage or scratch it.**
- **Handle the signal plate in a manner that prevents it from becoming magnetized.**

INSTALLATION

Installation is in the reverse order of removal.

- When installing the drive plate to the crankshaft, use the match mark (A) as shown to correctly align the crankshaft side dowel pin to the drive plate side dowel pin hole.

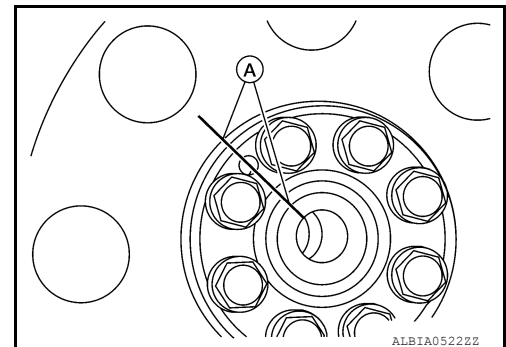

CYLINDER BLOCK

< UNIT DISASSEMBLY AND ASSEMBLY >

- Install the drive plate and the reinforcement plate in the direction as shown.

- A. : Signal plate
- B. : Crankshaft
- C. : Pilot converter
- D. : Reinforcement plate
- E. : Rounded
- F. : Ring gear
- ⇐ Engine front

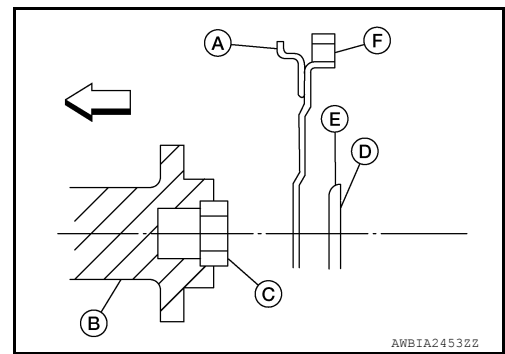

- Tighten the drive plate bolts to specification in a diagonal pattern. Refer to [EM-113, "Exploded View"](#).
- Use a suitable tool to lock the drive plate.

A

EM

C

D

E

F

G

H

I

J

K

L

M

N

O

P

SERVICE DATA AND SPECIFICATIONS (SDS)

< SERVICE DATA AND SPECIFICATIONS (SDS)

SERVICE DATA AND SPECIFICATIONS (SDS)

SERVICE DATA AND SPECIFICATIONS (SDS)

General Specification

INFOID:0000000011568115

GENERAL SPECIFICATIONS

Cylinder arrangement		V-6
Displacement cm ³ (cu in)		3,498 (213.45)
Bore and stroke mm (in)		95.5 x 81.4 (3.760 x 3.205)
Valve arrangement		DOHC
Firing order		1-2-3-4-5-6
Number of piston rings	Compression	2
	Oil	1
Number of main bearings		4
Compression ratio		10.3:1
Compression pressure kPa (kg/cm ² , psi)/300 rpm	Standard	1,275 (12.75, 13.0, 185)
	Minimum	981 (9.81, 10.0, 142)
	Differential limit between cylinders	98 (0.98, 1.0, 14)

Cylinder number

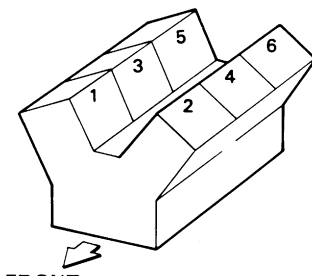

SEM713A

Valve timing
(Valve timing control - "OFF")

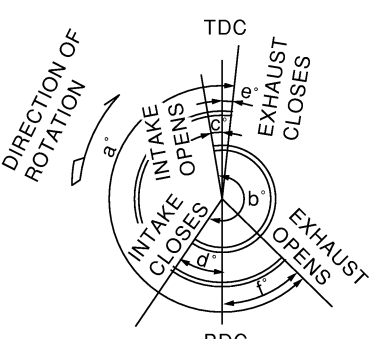

PBIC0187E

Unit: degree

a	b	c	d	e	f
240	240	-10	70	10	50

Drive Belt

INFOID:0000000011568116

DRIVE BELT

Tension of drive belt	Belt tension is not necessary, as it is automatically adjusted by drive belt auto-tensioner.
-----------------------	--

SERVICE DATA AND SPECIFICATIONS (SDS)

< SERVICE DATA AND SPECIFICATIONS (SDS)

Spark Plug

INFOID:0000000011568117

SPARK PLUG

Unit: mm (in)

Make	DENSO	
Standard type*	FXE22HR11	
Gap	Standard	1.1 (0.043)

*: Always check with the Parts Department for the latest parts information.

Intake Manifold

INFOID:0000000011568118

INTAKE MANIFOLD

Unit: mm (in)

Items		Limit
Surface distortion	Intake manifold	0.1 (0.004)

Exhaust Manifold

INFOID:0000000011568119

EXHAUST MANIFOLD

Unit: mm (in)

Items		Limit
Surface distortion	Exhaust manifold	0.3 (0.012)

Camshaft

INFOID:0000000011568120

CAMSHAFT

Unit: mm (in)

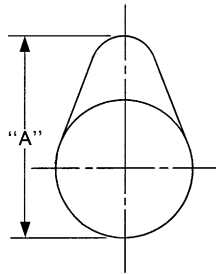

SEM671

Items		Standard	Limit
Camshaft journal oil clearance	No. 1	0.045 - 0.086 (0.0018 - 0.0034)	0.15 (0.0059)
	No. 2, 3, 4	0.035 - 0.076 (0.0014 - 0.0030)	
Camshaft bracket inner diameter	No. 1	26.000 - 26.021 (1.0236 - 1.0244)	—
	No. 2, 3, 4	23.500 - 23.521 (0.9252 - 0.9260)	—
Camshaft journal diameter	No. 1	25.935 - 25.955 (1.0211 - 1.0218)	—
	No. 2, 3, 4	23.445 - 23.465 (0.9230 - 0.9238)	—
Camshaft end play		0.115 - 0.188 (0.0045 - 0.0074)	0.24 (0.0094)
Camshaft lobe height "A"	Intake	45.475 - 45.665 (1.7904 - 1.7978)	0.2 (0.008)* ¹
	Exhaust	45.485 - 45.675 (1.7907 - 1.7982)	0.2 (0.008)* ¹
Camshaft runout [TIR* ²]		Less than 0.02 (0.0008)	0.05 (0.0020)
Camshaft sprocket runout [TIR* ²]		Less than 0.15 (0.0059)	—

SERVICE DATA AND SPECIFICATIONS (SDS)

< SERVICE DATA AND SPECIFICATIONS (SDS)

*1: Cam wear limit

*2: Total indicator reading

VALVE LIFTER

Unit: mm (in)

Items	Standard
Valve lifter outer diameter	33.977 - 33.987 (1.3377 - 1.3381)
Valve lifter bore diameter	34.000 - 34.016 (1.3386 - 1.3392)
Valve lifter clearance	0.023 - 0.029 (0.0009 - 0.0011)

VALVE CLEARANCE

Unit: mm (in)

Items	Cold	Hot* (reference data)
Intake	0.26 - 0.34 (0.010 - 0.013)	0.304 - 0.416 (0.012 - 0.016)
Exhaust	0.29 - 0.37 (0.011 - 0.015)	0.308 - 0.432 (0.012 - 0.017)

*: Approximately 80°C (176°F)

AVAILABLE VALVE LIFTER

Unit: mm (in)

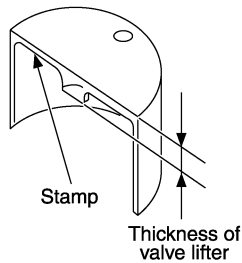

KBIA0119E

Thickness
3.00 (0.1181)
3.02 (0.1189)
3.04 (0.1197)
3.06 (0.1205)
3.08 (0.1213)
3.10 (0.1220)
3.12 (0.1228)
3.14 (0.1236)
3.16 (0.1244)
3.18 (0.1252)
3.20 (0.1260)
3.22 (0.1268)
3.24 (0.1276)
3.26 (0.1283)
3.28 (0.1291)
3.30 (0.1299)
3.32 (0.1307)
3.34 (0.1315)
3.36 (0.1323)

SERVICE DATA AND SPECIFICATIONS (SDS)

< SERVICE DATA AND SPECIFICATIONS (SDS)

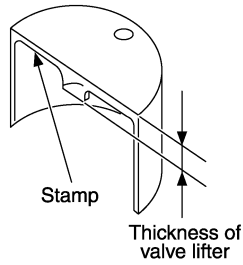

KBIA0119E

Thickness
3.38 (0.1331)
3.40 (0.1339)
3.42 (0.1346)
3.44 (0.1354)
3.46 (0.1362)
3.48 (0.1370)
3.50 (0.1378)

*: Always check with the Parts Department for the latest parts information.

Cylinder Head

INFOID:0000000011568121

CYLINDER HEAD

Unit: mm (in)

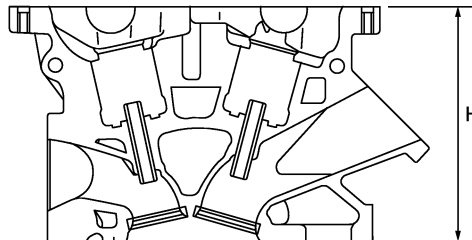

PBIC0924E

Items	Standard	Limit
Head surface distortion	Less than 0.03 (0.0012)	0.1 (0.004)
Normal cylinder head height (H)	126.4 (4.98)	—
Spark plug tube installation height	38.2 +0.5/- 0.5 (1.5 +0.020 / -0.020)	—

VALVE DIMENSIONS

SERVICE DATA AND SPECIFICATIONS (SDS)

< SERVICE DATA AND SPECIFICATIONS (SDS)

Unit: mm (in)

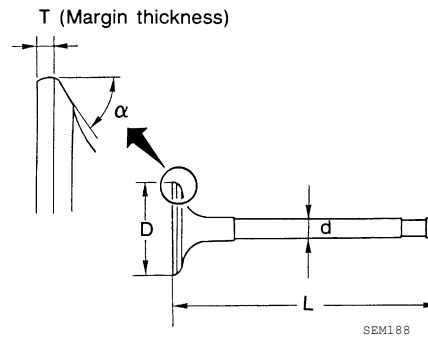

Valve head diameter (D)	Intake	36.6 - 36.9 (1.441 - 1.453)
	Exhaust	30.2 - 30.5 (1.189 - 1.201)
Valve length (L)	Intake	102.02 (4.0165)
	Exhaust	99.56 (3.9197)
Valve stem diameter (d)	Intake	5.965 - 5.980 (0.2348 - 0.2354)
	Exhaust	5.955 - 5.970 (0.2344 - 0.2350)
Valve seat angle α	Intake	45°15' - 45°45'
	Exhaust	
Valve margin (T)	Intake	1.15 - 1.45 (0.0453 - 0.0571)
	Exhaust	1.45 - 1.75 (0.0571 - 0.0689)
Valve margin (T) limit		More than 0.5 (0.020)
Valve stem end surface grinding limit		Less than 0.2 (0.008)

VALVE OIL SEAL

Unit: mm (in)

Description	Standard
Valve oil seal installation height	14.3 - 14.9 (0.563 - 0.587)

VALVE GUIDE

Unit: mm (in)

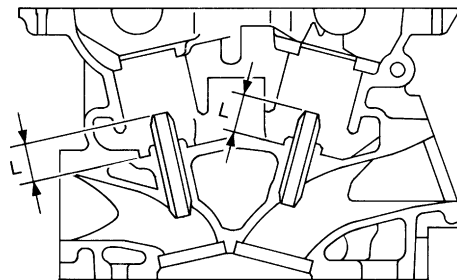

Items		Standard	Oversize (Service) [0.2 (0.008)]
Valve guide	Outer diameter	10.023 - 10.034 (0.3946 - 0.3950)	10.223 - 10.234 (0.4025 - 0.4029)
	Inner diameter (Finished size)	5.3 - 5.5 (0.2087 - 0.2165)	
Cylinder head valve guide hole diameter		9.975 - 9.996 (0.3927 - 0.3935)	10.175 - 10.196 (0.4006 - 0.4014)
Interference fit of valve guide		0.027 - 0.059 (0.0011 - 0.0023)	
Items		Standard	Limit

SERVICE DATA AND SPECIFICATIONS (SDS)

< SERVICE DATA AND SPECIFICATIONS (SDS)

Valve guide clearance	Intake	0.020 - 0.053 (0.0008 - 0.0021)	0.08 (0.0031)
	Exhaust	0.040 - 0.073 (0.0016 - 0.0029)	0.01 (0.004)
Valve deflection	Intake	—	0.24 (0.0094)
	Exhaust	—	0.28 (0.0110)
Projection length (L)		12.6 - 12.8 (0.496 - 0.504)	

VALVE SEAT

Unit: mm (in)

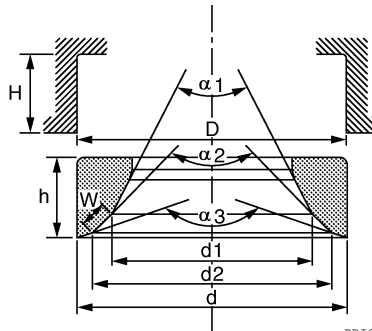

Items		Standard	Oversize (Service) [0.5 (0.02)]
Cylinder head seat recess diameter "D"	Intake	38.000 - 38.016 (1.4961 - 1.4967)	38.500 - 38.516 (1.5157 - 1.5164)
	Exhaust	31.600 - 31.616 (1.2441 - 1.2447)	32.100 - 32.116 (1.2638 - 1.2644)
Valve seat outer diameter "d"	Intake	38.097 - 38.113 (1.4999 - 1.5005)	38.597 - 38.613 (1.5196 - 1.5202)
	Exhaust	31.680 - 31.696 (1.2472 - 1.2479)	32.180 - 32.196 (1.2669 - 1.2676)
Valve seat interference fit	Intake	0.081 - 0.113 (0.0032 - 0.0044)	
	Exhaust	0.064 - 0.096 (0.0025 - 0.0038)	
Diameter "d1"*1	Intake	34.6 (1.362)	
	Exhaust	27.7 (1.091)	
Diameter "d2"*2	Intake	35.9 - 36.4 (1.413 - 1.433)	
	Exhaust	31.680 - 31.696 (1.2472 - 1.2479)	
Angle "α1"	Intake	30°	
	Exhaust	30°	
Angle "α2"	Intake	45°	
	Exhaust	45°	
Angle "α3"	Intake	60°	
	Exhaust	60°	
Contacting width "W"*3	Intake	1.18 - 1.22 (0.0465 - 0.0480)	
	Exhaust	1.38 - 1.42 (0.0543 - 0.0559)	
Height "h"	Intake	5.9 - 6.0 (0.232 - 0.236)	5.0 - 5.1 (0.197 - 0.201)
	Exhaust	5.9 - 6.0 (0.232 - 0.236)	4.9 - 5.0 (0.193 - 0.197)
Depth "H"	Intake	41.16 - 41.76 (1.6205 - 1.6441)	
	Exhaust	41.09 - 41.69 (1.6177 - 1.6413)	

*1: Diameter made by intersection point of conic angles "α1" and "α2"

*2: Diameter made by intersection point of conic angles "α2" and "α3"

*3: Machining data

VALVE SPRING

SERVICE DATA AND SPECIFICATIONS (SDS)

< SERVICE DATA AND SPECIFICATIONS (SDS)

Items	Standard
Free height	48.51 mm (1.9098 in)
Installation height	38.66 mm (1.5220 in)
Installation load	166 - 188 N (16.9 - 19.2 kg, 37.3 - 42.3 lb)
Height during valve open	28.66 mm (1.1283 in)
Load with valve open	384 - 432 N (39.2 - 44.1 kg, 86.3 - 97.1 lb)

Unit: mm (in)

Items	Limit
Squareness	2.0 (0.079)

Cylinder Block

INFOID:000000011568122

CYLINDER BLOCK

Unit: mm (in)

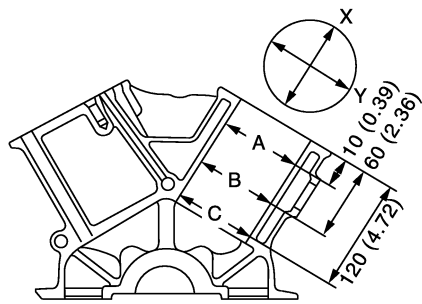

JPBIA2238GB

Surface distortion		Standard		Less than 0.03 (0.0012)
		Limit		0.10 (0.0039)
Cylinder bore	Main bearing housing inner diameter	Standard	Grade No. 1	95.500 - 95.510 (3.7598 - 3.7602)
			Grade No. 2	95.510 - 95.520 (3.7602 - 3.7606)
			Grade No. 3	95.520 - 95.530 (3.7606 - 3.7610)
		Wear limit	0.20 (0.0079)	
Out-of-round		Limit	0.015 (0.0006)	
Taper (Difference between A and C)			0.015 (0.0006)	

SERVICE DATA AND SPECIFICATIONS (SDS)

< SERVICE DATA AND SPECIFICATIONS (SDS)

Main bearing housing inner diameter grade (Without bearing)	Grade No. A	63.993 - 63.994 (2.5194 - 2.5194)
	Grade No. B	63.994 - 63.995 (2.5194 - 2.5195)
	Grade No. C	63.995 - 63.996 (2.5195 - 2.5195)
	Grade No. D	63.996 - 63.997 (2.5195 - 2.5196)
	Grade No. E	63.997 - 63.998 (2.5196 - 2.5196)
	Grade No. F	63.998 - 63.999 (2.5196 - 2.5196)
	Grade No. G	63.999 - 64.000 (2.5196 - 2.5197)
	Grade No. H	64.000 - 64.001 (2.5197 - 2.5197)
	Grade No. J	64.001 - 64.002 (2.5197 - 2.5198)
	Grade No. K	64.002 - 64.003 (2.5198 - 2.5198)
	Grade No. L	64.003 - 64.004 (2.5198 - 2.5198)
	Grade No. M	64.004 - 64.005 (2.5198 - 2.5199)
	Grade No. N	64.005 - 64.006 (2.5199 - 2.5199)
	Grade No. P	64.006 - 64.007 (2.5199 - 2.5200)
	Grade No. R	64.007 - 64.008 (2.5200 - 2.5200)
	Grade No. S	64.008 - 64.009 (2.5200 - 2.5200)
	Grade No. T	64.009 - 64.010 (2.5200 - 2.5201)
	Grade No. U	64.010 - 64.011 (2.5201 - 2.5201)
	Grade No. V	64.011 - 64.012 (2.5201 - 2.5202)
Grade No. W	64.012 - 64.013 (2.5202 - 2.5202)	
Grade No. X	64.013 - 64.014 (2.5202 - 2.5202)	
Grade No. Y	64.014 - 64.015 (2.5202 - 2.5203)	
Grade No. 4	64.015 - 64.016 (2.5203 - 2.5203)	
Grade No. 7	64.016 - 64.017 (2.5203 - 2.5203)	
Difference in inner diameter between cylinders	Standard	Less than 0.03 (0.0012)

AVAILABLE PISTON

Unit: mm (in)

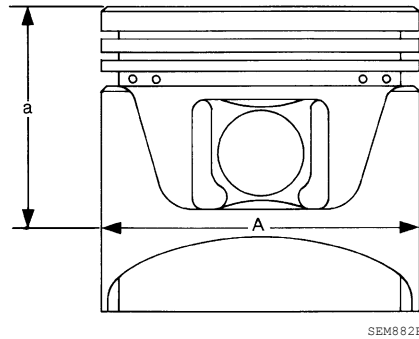

Items	Grade*	Standard
Piston skirt diameter (A)	Grade No. 1	95.480 - 95.490 (3.7590 - 3.7594)
	Grade No. 2	95.490 - 95.500 (3.7594 - 3.7598)
	Grade No. 3	95.500 - 95.510 (3.7598 - 3.7602)
(a) dimension		38.0 (1.496)
Piston pin hole diameter	Grade No. 0	21.993 - 21.999 (0.8659 - 0.8661)
	Grade No. 1	21.999 - 22.005 (0.8661 - 0.8663)
Piston to cylinder bore clearance		0.010 - 0.030 (0.0004 - 0.0012)

*: Always check with the Parts Department for the latest parts information.

PISTON RING

Unit: mm (in)

Items	Standard	Limit
Side clearance	Top	0.045 - 0.080 (0.0018 - 0.0031)
	2nd	0.030 - 0.070 (0.0012 - 0.0028)
	Oil ring	0.045 - 0.125 (0.0018 - 0.0049)

SERVICE DATA AND SPECIFICATIONS (SDS)

< SERVICE DATA AND SPECIFICATIONS (SDS)

End gap	Top	0.23 - 0.28 (0.0091 - 0.0110)	0.50 (0.0197)
	2nd	0.33 - 0.43 (0.0130 - 0.0169)	0.62 (0.0244)
	Oil (rail ring)	0.20 - 0.45 (0.0079 - 0.0177)	0.80 (0.0315)

PISTON PIN

Unit: mm (in)

Items	Grade*	Standard	Limit
Piston pin outer diameter	Grade No. 0	21.989 - 21.995 (0.8657 - 0.8659)	—
	Grade No. 1	21.995 - 22.001 (0.8659 - 0.8662)	—
Piston to piston pin oil clearance		0.002 - 0.006 (0.0001 - 0.0002)	—
Connecting rod bushing oil clearance		0.005 - 0.017 (0.0002 - 0.0007)	0.030 (0.0012)

*: Always check with the Parts Department for the latest parts information.

CONNECTING ROD

Unit: mm (in)

Center distance		144.15 - 144.25 (5.68 - 5.68)
Bend [per 100 (3.94)]	Limit	0.15 (0.0059)
Torsion [per 100 (3.94)]	Limit	0.30 (0.0118)
Connecting rod small end inner diameter		23.980 - 24.000 (0.9441 - (0.9449)
Connecting rod bushing inner diameter ²	Grade No. 0	22.000 - 22.006 (0.8661 - 0.8664)
	Grade No. 1	22.006 - 22.012 (0.8664 - 0.8666)
Connecting rod big end diameter (Without bearing)		55.000 - 55.013 (2.1654 - 2.1659)
Side clearance	Standard	0.20 - 0.35 (0.0079 - 0.0138)
	Limit	0.40 (0.0157)

¹: Always check with the Parts Department for the latest parts information.

²: After installing in connecting rod.

CRANKSHAFT

Unit: mm (in)

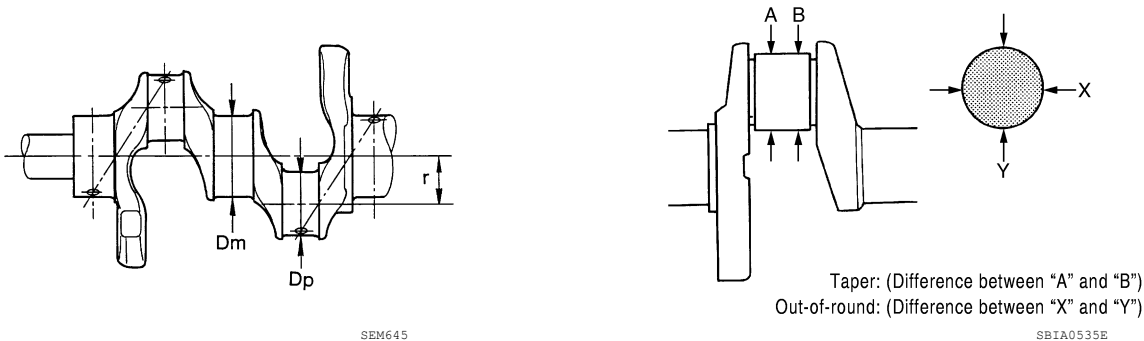

SERVICE DATA AND SPECIFICATIONS (SDS)

< SERVICE DATA AND SPECIFICATIONS (SDS)

		Grade ¹	Dimension
		Main journal diameter.(Dm) grade	Standard
Grade No. B	59.974 - 59.973 (2.3612 - 2.3611)		
Grade No. C	59.973 - 59.972 (2.3611 - 2.3611)		
Grade No. D	59.972 - 59.971 (2.3611 - 2.3611)		
Grade No. E	59.971 - 59.970 (2.3611 - 2.3610)		
Grade No. F	59.970 - 59.969 (2.3610 - 2.3610)		
Grade No. G	59.969 - 59.968 (2.3610 - 2.3609)		
Grade No. H	59.968 - 59.967 (2.3609 - 2.3609)		
Grade No. J	59.967 - 59.966 (2.3609 - 2.3609)		
Grade No. K	59.966 - 59.965 (2.3609 - 2.3608)		
Grade No. L	59.965 - 59.964 (2.3608 - 2.3608)		
Grade No. M	59.964 - 59.963 (2.3608 - 2.3607)		
Grade No. N	59.963 - 59.962 (2.3607 - 2.3607)		
Grade No. P	59.962 - 59.961 (2.3607 - 2.3607)		
Grade No. R	59.961 - 59.960 (2.3607 - 2.3606)		
Grade No. S	59.960 - 59.959 (2.3606 - 2.3606)		
Grade No. T	59.959 - 59.958 (2.3606 - 2.3605)		
Grade No. U	59.958 - 59.957 (2.3605 - 2.3605)		
Grade No. V	59.957 - 59.956 (2.3605 - 2.3605)		
Grade No. W	59.956 - 59.955 (2.3605 - 2.3604)		
Grade No. X	59.955 - 59.954 (2.3604 - 2.3604)		
Grade No. Y	59.954 - 59.953 (2.3604 - 2.3603)		
Grade No. 4	59.953 - 59.952 (2.3603 - 2.3603)		
Grade No. 7	59.952 - 59.951 (2.3603 - 2.3603)		
Pin journal diameter. (Dp) grade	Standard	Grade No. 0	51.968 - 51.974 (2.0460 - 2.0462)
		Grade No. 1	51.962 - 51.968 (2.0457 - 2.0460)
		Grade No. 2	51.956 - 51.962 (2.0445 - 2.0457)
Center distance (r)			40.66 - 40.74 (1.6008 - 1.6039)
Taper [Difference between (A) and (B)]	Limit		Less than 0.002 (0.0001)
Out-of-round [Difference between (X) and (Y)]			Less than 0.002 (0.0001)
Crankshaft runout [TIR*]	Standard		Less than 0.05 (0.0020)
	Limit		0.10 (0.0039)
Crankshaft end play	Standard		0.10 - 0.25 (0.0039 - 0.0098)
	Limit		0.30 (0.0118)
Fillet role of crankshaft journal	Standard		More than 0.10 (0.0039)

*: Total indicator reading

Main Bearing

INFOID:000000011568123

MAIN BEARING

Unit: mm (in)

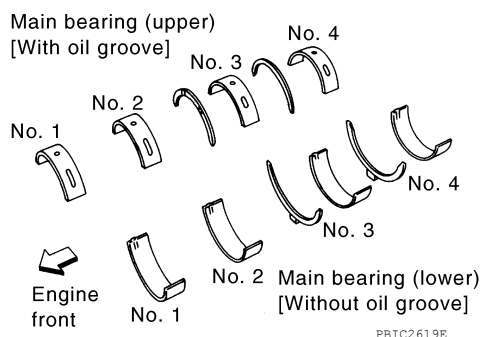

Grade number*	Thickness	Identification color	Remarks
---------------	-----------	----------------------	---------

SERVICE DATA AND SPECIFICATIONS (SDS)

< SERVICE DATA AND SPECIFICATIONS (SDS)

0		2.000 - 2.003 (0.0787 - 0.0789)	Black	Grade is the same for upper and lower bearings.
1		2.003 - 2.006 (0.0789 - 0.0790)	Brown	
2		2.006 - 2.009 (0.0790 - 0.0791)	Green	
3		2.009 - 2.012 (0.0791 - 0.0792)	Yellow	
4		2.012 - 2.015 (0.0792 - 0.0793)	Blue	
5		2.015 - 2.018 (0.0793 - 0.0794)	Pink	
6		2.018 - 2.021 (0.0794 - 0.0796)	Purple	
7		2.021 - 2.024 (0.0796 - 0.0797)	White	
01	UPR	2.003 - 2.006 (0.0789 - 0.0790)	Brown	Grade and color are different for upper and lower bearings.
	LWR	2.000 - 2.003 (0.0787 - 0.0789)	Black	
12	UPR	2.006 - 2.009 (0.0790 - 0.0791)	Green	
	LWR	2.003 - 2.006 (0.0789 - 0.0790)	Brown	
23	UPR	2.009 - 2.012 (0.0791 - 0.0792)	Yellow	
	LWR	2.006 - 2.009 (0.0790 - 0.0791)	Green	
34	UPR	2.012 - 2.015 (0.0792 - 0.0793)	Blue	
	LWR	2.009 - 2.012 (0.0791 - 0.0792)	Yellow	
45	UPR	2.015 - 2.018 (0.0793 - 0.0794)	Pink	
	LWR	2.012 - 2.015 (0.0792 - 0.0793)	Blue	
56	UPR	2.018 - 2.021 (0.0794 - 0.0796)	Purple	
	LWR	2.015 - 2.018 (0.0793 - 0.0794)	Pink	
67	UPR	2.021 - 2.024 (0.0796 - 0.0797)	White	
	LWR	2.018 - 2.021 (0.0794 - 0.0796)	Purple	

*: Always check with the Parts Department for the latest parts information.

UNDERSIZE

Unit: mm (in)

Items	Thickness	Main journal diameter
0.25 (0.0098)	2.132 - 2.140 (0.0839 - 0.0843)	Grind so that bearing clearance is the specified value.

MAIN BEARING OIL CLEARANCE

Unit: mm (in)

Items	Standard	Limit
Main bearing oil clearance	0.012 - 0.022 (0.0005 - 0.0009)*	0.065 (0.0026)

*: Actual clearance

Connecting Rod Bearing

INFOID:000000011568124

CONNECTING ROD BEARING

Unit: mm (in)

Grade number*	Thickness	Identification color (mark)
0	1.500 - 1.503 (0.0591 - 0.0592)	Black
1	1.503 - 1.506 (0.0592 - 0.0593)	Brown
2	1.506 - 1.509 (0.0593 - 0.0594)	Green

*: Always check with the Parts Department for the latest parts information.

UNDERSIZE

Unit: mm (in)

Items	Thickness	Crank pin journal diameter (Dp)
0.25 (0.0098)	1.626 - 1.634 (0.0640 - 0.0643)	Grind so that bearing clearance is the specified value.

SERVICE DATA AND SPECIFICATIONS (SDS)

< SERVICE DATA AND SPECIFICATIONS (SDS)

CONNECTING ROD BEARING OIL CLEARANCE

Unit: mm (in)

Items	Standard	Limit
Connecting rod bearing oil clearance	0.020 - 0.045 (0.0008 - 0.0018)*	0.070 (0.0028)

*: Actual clearance

Drive Plate

INFOID:000000011568125

Unit: mm (in)

Drive plate runout [TIR]* - on torque converter mount surface	Less than 0.35 (0.0138)
Drive plate runout [TIR]* - on ring gear	0.5 (0.0197)

*: Total indicator reading

A
EM
C
D
E
F
G
H
I
J
K
L
M
N
O
P