

SECTION **EXT**
EXTERIOR

A
B
C

CONTENTS

| | | | | |
|--|----|--|----|-----|
| PRECAUTION | 3 | SQUEAK AND RATTLE TROUBLE DIAG- NOSES | 18 | F |
| PRECAUTIONS | 3 | Work Flow | 18 | G |
| Precaution for Supplemental Restraint System (SRS) "AIR BAG" and "SEAT BELT PRE-TEN- SIONER" | 3 | Generic Squeak and Rattle Troubleshooting | 19 | |
| Procedure without Cowl Top Cover | 3 | Diagnostic Worksheet | 22 | |
| Precaution for Work | 3 | REMOVAL AND INSTALLATION | 24 | H |
| PREPARATION | 5 | FRONT BUMPER | 24 | I |
| PREPARATION | 5 | Exploded View | 24 | |
| Special Service Tools | 5 | Removal and Installation | 25 | |
| Commercial Service Tools | 5 | REAR BUMPER | 27 | J |
| CLIP LIST | 6 | Exploded View | 27 | |
| Descriptions for Clips | 6 | Removal and Installation | 27 | |
| SYSTEM DESCRIPTION | 10 | FRONT GRILLE | 30 | EXT |
| COMPONENT PARTS | 10 | Exploded View | 30 | |
| ACTIVE GRILLE SHUTTER SYSTEM | 10 | Removal and Installation | 30 | |
| ACTIVE GRILLE SHUTTER SYSTEM : | | ACTIVE GRILLE SHUTTER | 32 | L |
| Component Parts Location | 10 | Exploded View | 32 | |
| ACTIVE GRILLE SHUTTER SYSTEM : Active grille shutter | 11 | Removal and Installation | 32 | |
| SYSTEM | 12 | FRONT SPOILER | 33 | M |
| ACTIVE GRILLE SHUTTER SYSTEM | 12 | Exploded View | 33 | |
| ACTIVE GRILLE SHUTTER SYSTEM : System Diagram | 12 | Removal and Installation | 33 | |
| ACTIVE GRILLE SHUTTER SYSTEM : System Description | 12 | COWL TOP | 34 | N |
| WIRING DIAGRAM | 14 | Exploded View | 34 | |
| ACTIVE GRILLE SHUTTER | 14 | Removal and Installation - Cowl Top Cover | 34 | |
| Wiring Diagram | 14 | Removal and Installation - Cowl Top Extension | 35 | O |
| SYMPTOM DIAGNOSIS | 18 | FENDER PROTECTOR | 36 | |
| | | FENDER PROTECTOR | 36 | P |
| | | FENDER PROTECTOR : Exploded View | 36 | |
| | | FENDER PROTECTOR : Removal and Installa- tion | 36 | |
| | | REAR WHEEL HOUSE PROTECTOR | 36 | |
| | | REAR WHEEL HOUSE PROTECTOR : Exploded View | 37 | |

| | | | |
|---|-----------|---|-----------|
| REAR WHEEL HOUSE PROTECTOR : Removal and Installation | 37 | ROOF RACK | 43 |
| OVER FENDER | 38 | Exploded View | 43 |
| FRONT OVER FENDER | 38 | Removal and Installation | 43 |
| FRONT OVER FENDER : Exploded View | 38 | DOOR SASH MOLDING | 44 |
| FRONT OVER FENDER : Removal and Installation | 38 | Exploded View | 44 |
| REAR OVER FENDER | 38 | Removal and Installation | 44 |
| REAR OVER FENDER : Exploded View | 39 | DOOR OUTSIDE MOLDING | 46 |
| REAR OVER FENDER : Removal and Installation.. | 39 | Exploded View | 46 |
| UNDER COVER | 40 | Removal and Installation | 46 |
| Exploded View | 40 | DOOR OUTSIDE LOWER MOLDING | 48 |
| FRONT UNDER COVER | 40 | Exploded View | 48 |
| FRONT UNDER COVER : Removal and Installation | 40 | Removal and Installation | 48 |
| FLOOR UNDER COVER | 40 | QUARTER GLASS MOLDING | 50 |
| FLOOR UNDER COVER : Removal and Installation | 40 | Exploded View | 50 |
| REAR UNDER COVER | 40 | Removal and Installation | 50 |
| REAR UNDER COVER : Removal and Installation | 40 | REAR SPOILER | 51 |
| ... | 40 | Exploded View | 51 |
| ROOF SIDE MOLDING | 42 | Removal and Installation | 51 |
| Exploded View | 42 | SIDE AIR SPOILER | 52 |
| Removal and Installation | 42 | Exploded View | 52 |
| | | Removal and Installation | 52 |
| | | BACK DOOR OUTER FINISHER | 53 |
| | | Exploded View | 53 |
| | | Removal and Installation | 53 |

PRECAUTIONS

< PRECAUTION >

PRECAUTION

PRECAUTIONS

Precaution for Supplemental Restraint System (SRS) "AIR BAG" and "SEAT BELT PRE-TENSIONER"

INFOID:000000011794418

The Supplemental Restraint System such as "AIR BAG" and "SEAT BELT PRE-TENSIONER", used along with a front seat belt, helps to reduce the risk or severity of injury to the driver and front passenger for certain types of collision. Information necessary to service the system safely is included in the SR and SB section of this Service Manual.

WARNING:

- To avoid rendering the SRS inoperative, which could increase the risk of personal injury or death in the event of a collision which would result in air bag inflation, all maintenance must be performed by an authorized NISSAN/INFINITI dealer.
- Improper maintenance, including incorrect removal and installation of the SRS, can lead to personal injury caused by unintentional activation of the system. For removal of Spiral Cable and Air Bag Module, see the SR section.
- Do not use electrical test equipment on any circuit related to the SRS unless instructed to in this Service Manual. SRS wiring harnesses can be identified by yellow and/or orange harnesses or harness connectors.

PRECAUTIONS WHEN USING POWER TOOLS (AIR OR ELECTRIC) AND HAMMERS

WARNING:

- When working near the Airbag Diagnosis Sensor Unit or other Airbag System sensors with the Ignition ON or engine running, DO NOT use air or electric power tools or strike near the sensor(s) with a hammer. Heavy vibration could activate the sensor(s) and deploy the air bag(s), possibly causing serious injury.
- When using air or electric power tools or hammers, always switch the Ignition OFF, disconnect the battery and wait at least three minutes before performing any service.

Procedure without Cowl Top Cover

INFOID:000000011241608

When performing the procedure after removing cowl top cover, cover the lower end of windshield with urethane, etc. to prevent damage to the windshield.

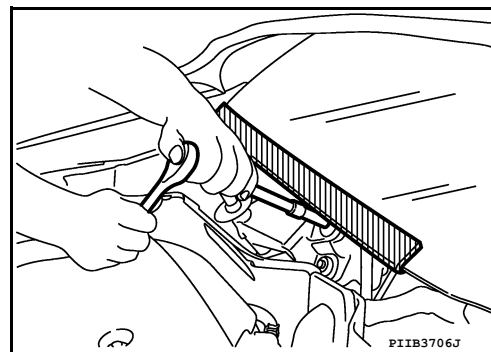

Precaution for Work

INFOID:000000011241609

- When removing or disassembling each component, be careful not to damage or deform it. If a component may be subject to interference, be sure to protect it with a shop cloth.
- When removing (disengaging) components with a screwdriver or similar tool, be sure to wrap the component with a shop cloth or vinyl tape to protect it.
- Protect the removed parts with a shop cloth and prevent them from being dropped.
- Replace a deformed or damaged clip.
- If a part is specified as a non-reusable part, always replace it with a new one.
- Be sure to tighten bolts and nuts securely to the specified torque.
- After installation is complete, be sure to check that each part works properly.
- Follow the steps below to clean components:
 - Water soluble dirt:
 - Dip a soft cloth into lukewarm water, wring the water out of the cloth and wipe the dirty area.
 - Then rub with a soft, dry cloth.
 - Oily dirt:

A

B

C

D

E

F

G

H

I

J

EXT

L

M

N

O

P

PRECAUTIONS

< PRECAUTION >

- Dip a soft cloth into lukewarm water with mild detergent (concentration: within 2 to 3%) and wipe the dirty area.
- Then dip a cloth into fresh water, wring the water out of the cloth and wipe the detergent off.
- Then rub with a soft, dry cloth.
- Do not use organic solvent such as thinner, benzene, alcohol or gasoline.
- For genuine leather seats, use a genuine leather seat cleaner.

PREPARATION

< PREPARATION >

PREPARATION

PREPARATION

Special Service Tools

INFOID:000000011241610

The actual shape of the tools may differ from those illustrated here.

| Tool number (TechMate No.) Tool name | Description |
|---|------------------------------|
| — (J-39570) Chassis Ear | Locating the noise |
| — (J-50397) NISSAN Squeak and Rattle Kit | Repairing the cause of noise |
| — (J-46534) Trim Tool Set | Removing trim components |

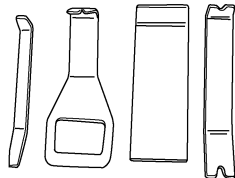
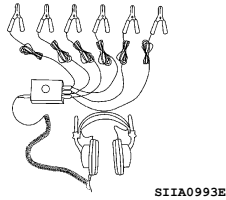

Commercial Service Tools

INFOID:000000011241611

EXT

| (TechMate No.) Tool name | Description |
|-----------------------------|----------------------------------|
| (J-39565) Engine Ear | Locating the noise |
| (—) Power tool | Loosening nuts, screws and bolts |

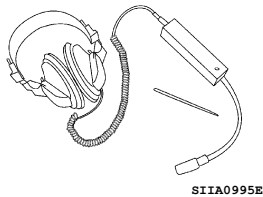

CLIP LIST







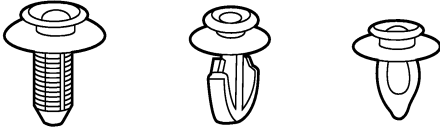

< PREPARATION >

CLIP LIST

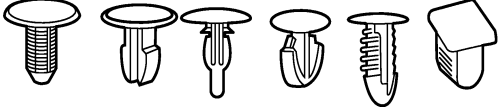
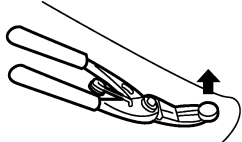
Descriptions for Clips

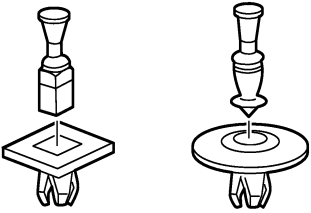
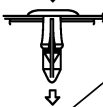
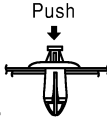
INFOID:000000011241612

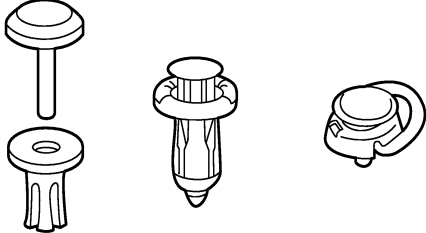
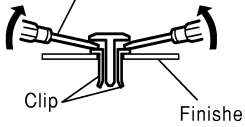

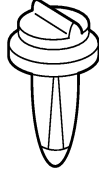
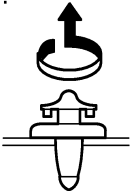





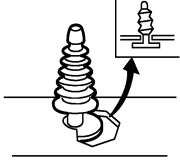
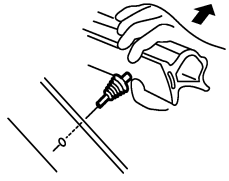

Replace any clips which are damaged during removal or installation.

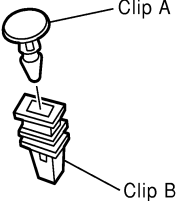
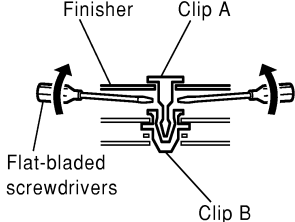
| Symbol No. | Shapes | Removal & Installation |
|---|---|--|
| <p>C101</p>  |  | <p>Removal: Remove by bending up with flat-bladed screwdrivers or clip remover.</p>  |
| <p>C103</p>  |  |  <p>Removal: Remove with a clip remover.</p> |
| <p>C203</p>  |  | <p>Removal: Push center pin to catching position. (Do not remove center pin by hitting it.)</p> <p>Push</p>  <p>Installation:</p>  |
| <p>C205</p>  |  | <p>Removal:</p>  <p>Flat-bladed screwdriver</p> <p>Clip</p> <p>Finisher</p> |
| <p>C206</p>  |  | <p>Removal:</p>  |

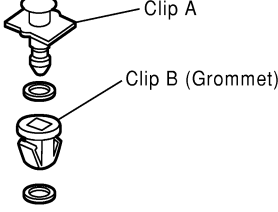
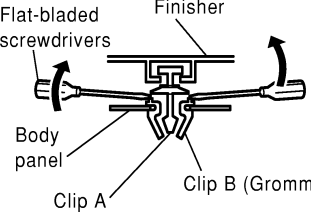
S11A0315E

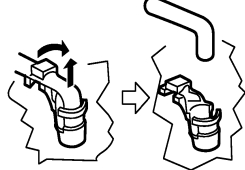
CLIP LIST

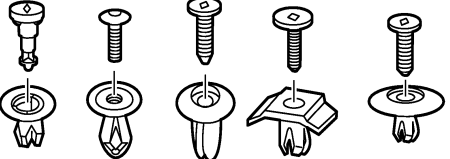
< PREPARATION >









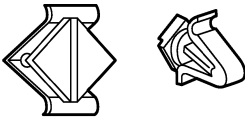

| Symbol No. | Shapes | Removal & Installation |
|--|---|--|
| <p>CE103</p>  |  | <p>Removal:</p>  |
| <p>CF110</p>  |  | <p>Removal:</p>  |
| <p>CF118</p>  |  | <p>Removal:</p>  |
| <p>CR103</p>  |  | <p>Removal: Holder portion of clip must be spread out to remove rod.</p>  |
| <p>CS101</p>  |  | <p>Removal:</p> <ol style="list-style-type: none"> 1. Screw out with a Phillips screwdriver. 2. Remove female portion with flat-bladed screwdriver.  |

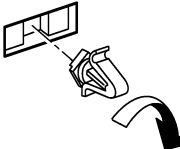
SIIA0316E

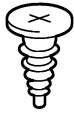
A
B
C
D
E
F
G
H
I
J
EXT
L
M
N
O
P

CLIP LIST

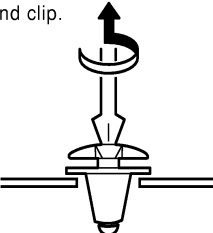

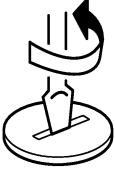
< PREPARATION >

| Symbol No. | Shapes | Removal & Installation | |
|--|---|---|---|
| CG101  |  | Removal:  Rotate 45° to remove | Installation:  |
| CS102  |  |  | |
| CS113  |  | Removal: Disconnect upper connection of clip with a flat-bladed screwdriver, then remove clip while inserting a flat-bladed screwdriver between body panel and clip.  | |
| C111  |  |  | |

SIIA0317E

CLIP LIST

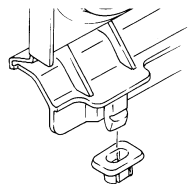
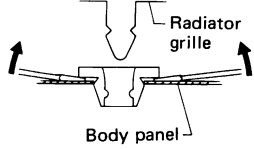
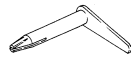
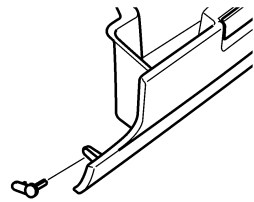
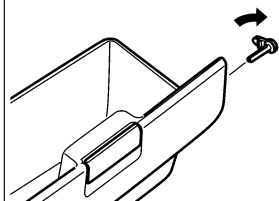
< PREPARATION >

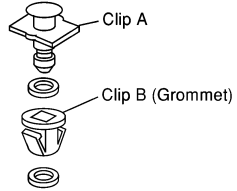
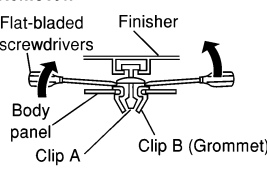
| Symbol No. | Shapes | Removal & Installation |
|--|---|--|
| <p>CG104</p>  |  | <p>Removal: Remove by bending up with flat-bladed screwdrivers.</p>  |
| <p>CE114</p>  |  |  |
| <p>CF118</p>  |  | <p>Removal: Flat-bladed screwdrivers Finisher</p>  |

ALJIA0564GB

A
B
C
D
E
F
G
H
I
J
L
M
N
O
P

EXT

COMPONENT PARTS

< SYSTEM DESCRIPTION >

SYSTEM DESCRIPTION

COMPONENT PARTS

ACTIVE GRILLE SHUTTER SYSTEM

ACTIVE GRILLE SHUTTER SYSTEM : Component Parts Location

INFOID:000000011241613

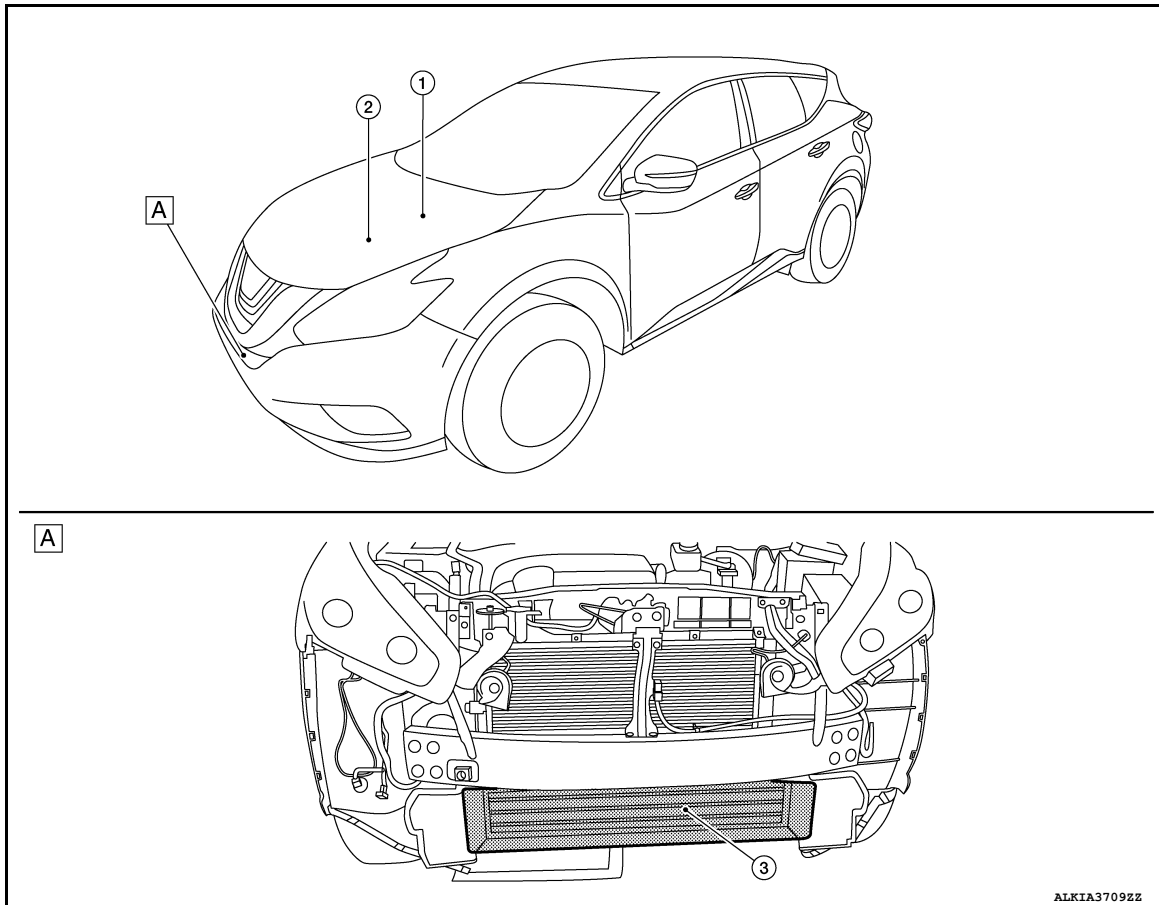

A. Behind front bumper fascia

| No. | Component | Reference |
|-----|-----------------------|---|
| 1. | IPDM E/R | Refer to PCS-5, "Component Parts Location" . |
| 2. | ECM | Refer to EC-21, "ECM" . |
| 3. | Active grille shutter | Refer to EXT-11, "ACTIVE GRILLE SHUTTER SYSTEM : Active grille shutter" . |

For the engine related component parts, refer to [EC-15, "ENGINE CONTROL SYSTEM : Component Parts Location"](#).

COMPONENT PARTS

< SYSTEM DESCRIPTION >

ACTIVE GRILLE SHUTTER SYSTEM : Active grille shutter

INFOID:000000011241614

Active grille shutter is located at front bumper lower opening, and according to the signal from ECM it operates actuator ① to perform open/close movement of flap ② to control the amount of air flow taken into engine compartment.

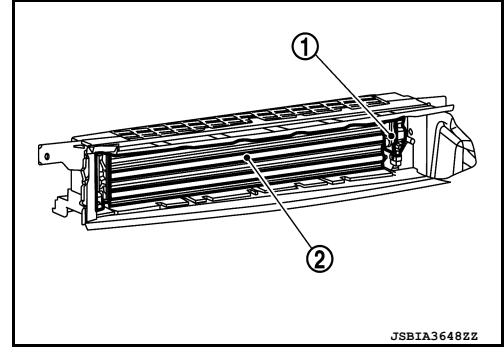

A
B
C
D
E
F
G
H
I
J
EXT
L
M
N
O
P

SYSTEM

< SYSTEM DESCRIPTION >

SYSTEM

ACTIVE GRILLE SHUTTER SYSTEM

ACTIVE GRILLE SHUTTER SYSTEM : System Diagram

INFOID:000000011241615

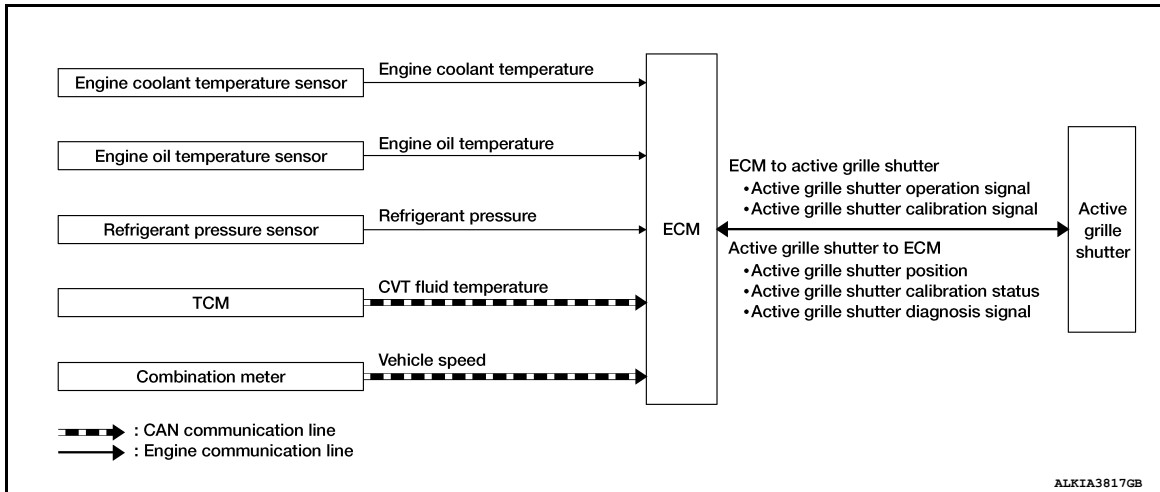

ACTIVE GRILLE SHUTTER SYSTEM : System Description

INFOID:000000011241616

While driving, the active grille shutter system closes shutter to reduce air flow to engine compartment for the purpose of reducing aerodynamic drag, and as a result, improves the vehicle's fuel efficiency.

ECM controls active grille shutter system by detecting vehicle status through respective modules and sensors. Active grille shutter actuator is equipped with self-diagnosis function. When a malfunction is detected, a signal is transmitted to the ECM and the ECM records the active grille shutter malfunction.

BASIC MOVEMENTS

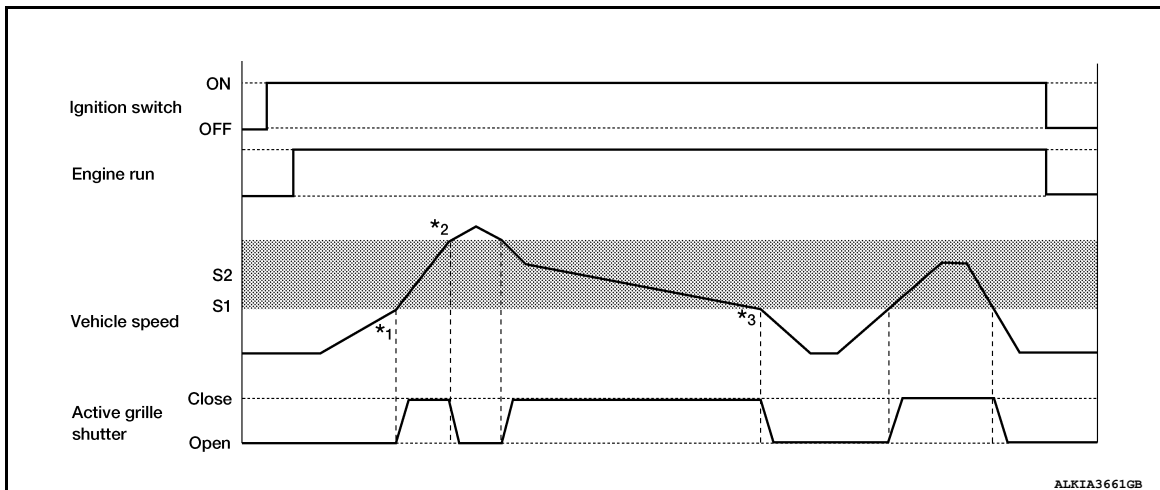

- S1: 30 km/h (19 MPH)
- S2: Approx. 30 - 140 km/h (19 - 88 MPH)
- *1: Shutter initial position learning
- *2: Judgment of high vehicle speed
- *3: Judgment of low vehicle speed

DESCRIPTION OF MOVEMENTS

Active grille shutter is fully open when the vehicle stops or the ignition switch is turned OFF.

ECM operates the shutter to close position in order to perform shutter's initial position learning whenever the ignition switch is turned OFF → ON and the engine is started. At the end of initial position learning ECM operates shutter to open position.

While driving, after the initial position learning ends, ECM operates the active grille shutter to close position when the operational conditions of active grille shutter are met.

While driving at high speed, ECM operates the shutter to open position when the vehicle reaches the specified speed in order to prevent the shutter from shutting up due to wind resistance.

SYSTEM

< SYSTEM DESCRIPTION >

When the vehicle speed is reduced below the specified speed ECM operates active grille shutter to open position.

NOTE:

- When any one of the conditions for opening the active grille shutter is satisfied, ECM performs active grille shutter initial position learning even when the vehicle speed is less than 30 km/h.
- ECM may perform active grille shutter initial position learning according to other diagnosis conditions.

ACTIVE GRILLE SHUTTER OPERATIONAL CONDITIONS

ECM operates active grille shutter to close position when all of the following conditions are met.

| Item | Status |
|---|--|
| Active grille shutter initial position learning | Complete |
| Vehicle speed | Approx. 30 - 140 km/h (19 - 88 MPH) |
| Engine coolant temperature | Approx. less than 95°C (203°F) |
| Engine oil temperature | Approx. less than 140°C (284°F) |
| CVT fluid temperature | Approx. less than 135°C (275°F) |
| Cooling fan | OFF |
| Refrigerant pressure | 0.78 MPa (7.95 kg/cm ² , 113.1 psi) or less |
| Malfunction of engine coolant temperature sensor system | Not detected |
| Malfunction of engine oil temperature sensor system | Not detected |
| Malfunction of vehicle speed sensor system | Not detected |
| Malfunction of CAN communication system | Not detected |

ECM operates active grille shutter to open position when one of the following conditions is met.

| Item | Status |
|---|---|
| Vehicle speed | <ul style="list-style-type: none"> • 22 km/h (14 MPH) or less • 140 km/h (88 MPH) or more |
| Engine coolant temperature | Approx. 95°C (203°F) or more |
| Engine oil temperature | Approx. 140°C (284°F) or more |
| CVT fluid temperature | Approx. 135°C (275°F) or more |
| Cooling fan | ON |
| Refrigerant pressure | 1.18 MPa (12.04 kg/cm ² , 171.1 psi) or more |
| Malfunction of engine coolant temperature sensor system | Detected |
| Malfunction of engine oil temperature sensor system | Detected |
| Malfunction of vehicle speed sensor system | Detected |
| Malfunction of CAN communication system | Detected |

ACTIVE GRILLE SHUTTER

< WIRING DIAGRAM >

WIRING DIAGRAM

ACTIVE GRILLE SHUTTER

Wiring Diagram

INFOID:000000011241617

ACTIVE GRILLE SHUTTER SYSTEM

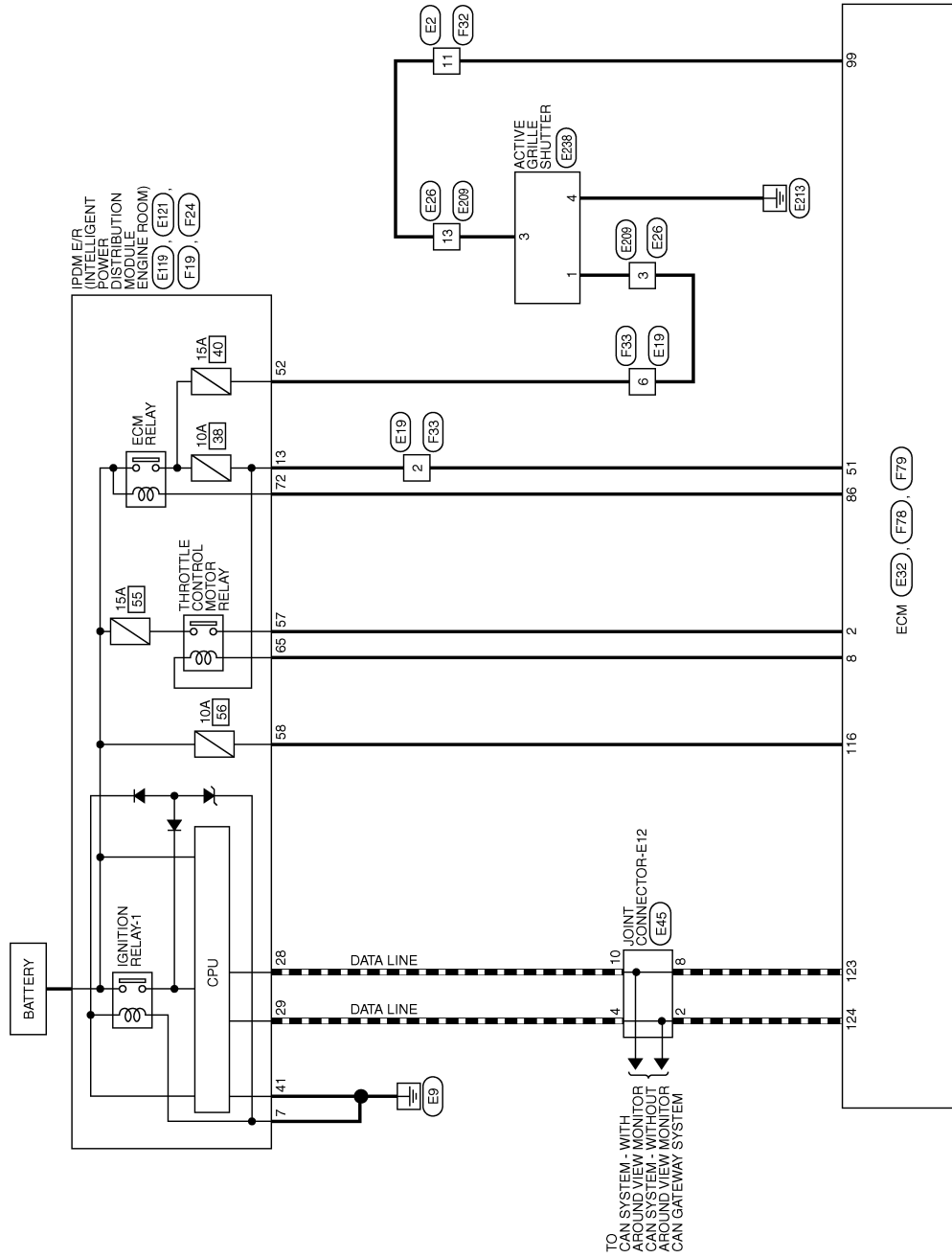

AAKWA1033GB

ACTIVE GRILLE SHUTTER

< WIRING DIAGRAM >

ACTIVE GRILLE SHUTTER SYSTEM CONNECTORS

| | |
|-----------------|--------------|
| Connector No. | E2 |
| Connector Name | WIRE TO WIRE |
| Connector Color | WHITE |

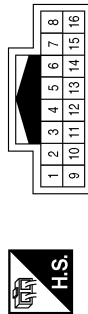

| Terminal No. | Color of Wire | Signal Name |
|--------------|---------------|-------------|
| 11 | B | - |

| | |
|-----------------|--------------|
| Connector No. | E19 |
| Connector Name | WIRE TO WIRE |
| Connector Color | BROWN |



| Terminal No. | Color of Wire | Signal Name |
|--------------|---------------|-------------|
| 2 | L | - |
| 6 | R | - |

| | |
|-----------------|--------------|
| Connector No. | E26 |
| Connector Name | WIRE TO WIRE |
| Connector Color | WHITE |

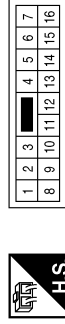

| Terminal No. | Color of Wire | Signal Name |
|--------------|---------------|-------------|
| 3 | R | - |
| 13 | B | - |

| | |
|-----------------|-------|
| Connector No. | E32 |
| Connector Name | ECM |
| Connector Color | BLACK |

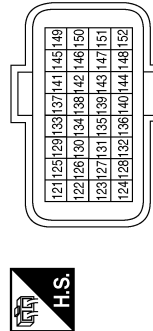

| Terminal No. | Color of Wire | Signal Name |
|--------------|---------------|-------------|
| 123 | P | CAN-L |
| 124 | L | CAN-H |

| | |
|-----------------|---------------------|
| Connector No. | E45 |
| Connector Name | JOINT CONNECTOR-E12 |
| Connector Color | BLUE |



| Terminal No. | Color of Wire | Signal Name |
|--------------|---------------|-------------|
| 2 | L | - |
| 4 | L | - |
| 8 | P | - |
| 10 | P | - |

| | |
|-----------------|--|
| Connector No. | E119 |
| Connector Name | IPDM E/R (INTELLIGENT POWER DISTRIBUTION MODULE ENGINE ROOM) |
| Connector Color | WHITE |

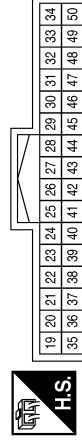

| Terminal No. | Color of Wire | Signal Name |
|--------------|---------------|-------------|
| 28 | P | CAN-L |
| 29 | L | CAN-H |
| 41 | B | S-GND |

AAKIA2481GB

A B C D E F G H I J L M N O P EXT

ACTIVE GRILLE SHUTTER

< WIRING DIAGRAM >

| | |
|-----------------|-----------------------|
| Connector No. | E238 |
| Connector Name | ACTIVE GRILLE SHUTTER |
| Connector Color | BLACK |

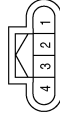

| Terminal No. | Color of Wire | Signal Name |
|--------------|---------------|-------------|
| 1 | BR | - |
| 3 | BR/V | - |
| 4 | B | - |

| | |
|-----------------|--------------|
| Connector No. | E209 |
| Connector Name | WIRE TO WIRE |
| Connector Color | WHITE |

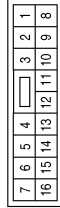

| Terminal No. | Color of Wire | Signal Name |
|--------------|---------------|-------------|
| 3 | BR | - |
| 13 | BR/V | - |

| | |
|-----------------|--|
| Connector No. | E121 |
| Connector Name | IPDM E/R (INTELLIGENT POWER DISTRIBUTION MODULE ENGINE ROOM) |
| Connector Color | WHITE |

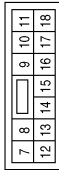

| Terminal No. | Color of Wire | Signal Name |
|--------------|---------------|-------------|
| 7 | B | P-GND |
| 13 | L | ECM VB |

| | |
|-----------------|--------------|
| Connector No. | F32 |
| Connector Name | WIRE TO WIRE |
| Connector Color | WHITE |

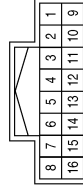

| Terminal No. | Color of Wire | Signal Name |
|--------------|---------------|-------------|
| 11 | L | - |

| | |
|-----------------|--|
| Connector No. | F24 |
| Connector Name | IPDM E/R (INTELLIGENT POWER DISTRIBUTION MODULE ENGINE ROOM) |
| Connector Color | WHITE |



| Terminal No. | Color of Wire | Signal Name |
|--------------|---------------|--------------|
| 65 | G | ETC RLY CONT |
| 72 | V | SSOFF |

| | |
|-----------------|--|
| Connector No. | F19 |
| Connector Name | IPDM E/R (INTELLIGENT POWER DISTRIBUTION MODULE ENGINE ROOM) |
| Connector Color | WHITE |

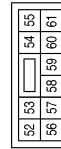

| Terminal No. | Color of Wire | Signal Name |
|--------------|---------------|-------------|
| 52 | W | O2SENS #2 |
| 57 | R | ETC |
| 58 | GR | ECM BAT |

AAKIA2482GB

ACTIVE GRILLE SHUTTER

< WIRING DIAGRAM >

| | |
|-----------------|-------|
| Connector No. | F79 |
| Connector Name | ECM |
| Connector Color | BLACK |

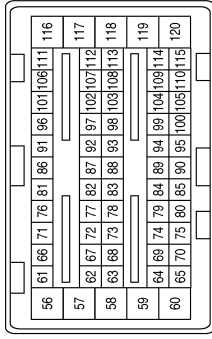

| Terminal No. | Color of Wire | Signal Name |
|--------------|---------------|-------------|
| 86 | V | SSOFF |
| 99 | L | LIN |
| 116 | GR | BATT |

| | |
|-----------------|-------|
| Connector No. | F78 |
| Connector Name | ECM |
| Connector Color | BLACK |

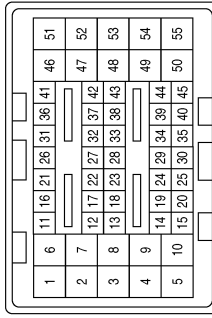

| Terminal No. | Color of Wire | Signal Name |
|--------------|---------------|-------------|
| 2 | R | VMOT |
| 8 | G | MOTRLY |
| 51 | L | VTCV |

| | |
|-----------------|--------------|
| Connector No. | F33 |
| Connector Name | WIRE TO WIRE |
| Connector Color | BROWN |

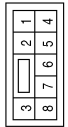

| Terminal No. | Color of Wire | Signal Name |
|--------------|---------------|-------------|
| 2 | L | - |
| 6 | W | - |

A
B
C
D
E
F
G
H
I
J
EXT
L
M
N
O
P

SQUEAK AND RATTLE TROUBLE DIAGNOSES

< SYMPTOM DIAGNOSIS >

SYMPTOM DIAGNOSIS

SQUEAK AND RATTLE TROUBLE DIAGNOSES

Work Flow

INFOID:000000011241618

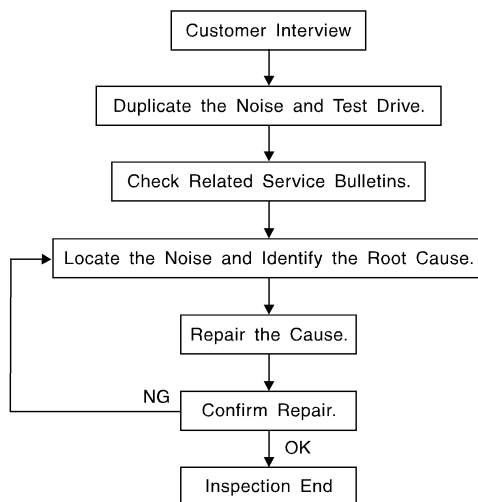

SBT842

CUSTOMER INTERVIEW

Interview the customer if possible, to determine the conditions that exist when the noise occurs. Use the Diagnostic Worksheet during the interview to document the facts and conditions when the noise occurs and any customer's comments; refer to [EXT-22. "Diagnostic Worksheet"](#). This information is necessary to duplicate the conditions that exist when the noise occurs.

- The customer may not be able to provide a detailed description or the location of the noise. Attempt to obtain all the facts and conditions that exist when the noise occurs (or does not occur).
- If there is more than one noise in the vehicle, be sure to diagnose and repair the noise that the customer is concerned about. This can be accomplished by test driving the vehicle with the customer.
- After identifying the type of noise, isolate the noise in terms of its characteristics. The noise characteristics are provided so the customer, service adviser and technician are all speaking the same language when defining the noise.
- Squeak —(Like tennis shoes on a clean floor)
Squeak characteristics include the light contact/fast movement/brought on by road conditions/hard surfaces = higher pitch noise/softer surfaces = lower pitch noises/edge to surface = chirping.
- Creak—(Like walking on an old wooden floor)
Creak characteristics include firm contact/slow movement/twisting with a rotational movement/pitch dependent on materials/often brought on by activity.
- Rattle—(Like shaking a baby rattle)
Rattle characteristics include the fast repeated contact/vibration or similar movement/loose parts/missing clip or fastener/incorrect clearance.
- Knock —(Like a knock on a door)
Knock characteristics include hollow sounding/sometimes repeating/often brought on by driver action.
- Tick—(Like a clock second hand)
Tick characteristics include gentle contacting of light materials/loose components/can be caused by driver action or road conditions.
- Thump—(Heavy, muffled knock noise)
Thump characteristics include softer knock/dead sound often brought on by activity.
- Buzz—(Like a bumble bee)
Buzz characteristics include high frequency rattle/firm contact.
- Often the degree of acceptable noise level will vary depending upon the person. A noise that you may judge as acceptable may be very irritating to the customer.
- Weather conditions, especially humidity and temperature, may have a great effect on noise level.

DUPLICATE THE NOISE AND TEST DRIVE

SQUEAK AND RATTLE TROUBLE DIAGNOSES

< SYMPTOM DIAGNOSIS >

If possible, drive the vehicle with the customer until the noise is duplicated. Note any additional information on the Diagnostic Worksheet regarding the conditions or location of the noise. This information can be used to duplicate the same conditions when you confirm the repair.

If the noise can be duplicated easily during the test drive, to help identify the source of the noise, try to duplicate the noise with the vehicle stopped by doing one or all of the following:

- 1) Close a door.
 - 2) Tap or push/pull around the area where the noise appears to be coming from.
 - 3) Rev the engine.
 - 4) Use a floor jack to recreate vehicle "twist".
 - 5) At idle, apply engine load (electrical load, half-clutch on M/T model, drive position on CVT and A/T models).
 - 6) Raise the vehicle on a hoist and hit a tire with a rubber hammer.
- Drive the vehicle and attempt to duplicate the conditions the customer states exist when the noise occurs.
 - If it is difficult to duplicate the noise, drive the vehicle slowly on an undulating or rough road to stress the vehicle body.

CHECK RELATED SERVICE BULLETINS

After verifying the customer concern or symptom, check ASIST for Technical Service Bulletins (TSBs) related to that concern or symptom.

If a TSB relates to the symptom, follow the procedure to repair the noise.

LOCATE THE NOISE AND IDENTIFY THE ROOT CAUSE

1. Narrow down the noise to a general area. To help pinpoint the source of the noise, use a listening tool (Chassis Ear: J-39570, Engine Ear: J-39565 and mechanic's stethoscope).
2. Narrow down the noise to a more specific area and identify the cause of the noise by:
 - removing the components in the area that you suspect the noise is coming from.
Do not use too much force when removing clips and fasteners, otherwise clips and fasteners can be broken or lost during the repair, resulting in the creation of new noise.
 - tapping or pushing/pulling the component that you suspect is causing the noise.
Do not tap or push/pull the component with excessive force, otherwise the noise will be eliminated only temporarily.
 - feeling for a vibration with your hand by touching the component(s) that you suspect is (are) causing the noise.
 - placing a piece of paper between components that you suspect are causing the noise.
 - looking for loose components and contact marks.Refer to [EXT-19, "Generic Squeak and Rattle Troubleshooting"](#).

REPAIR THE CAUSE

- If the cause is a loose component, tighten the component securely.
- If the cause is insufficient clearance between components:
 - separate components by repositioning or loosening and retightening the component, if possible.
 - insulate components with a suitable insulator such as urethane pads, foam blocks, felt cloth tape or urethane tape. A NISSAN Squeak and Rattle Kit (J-50397) is available through your authorized NISSAN Parts Department.

CAUTION:

Do not use excessive force as many components are constructed of plastic and may be damaged.

NOTE:

- Always check with the Parts Department for the latest parts information.
- The materials contained in the NISSAN Squeak and Rattle Kit (J-50397) are listed on the inside cover of the kit; and can each be ordered separately as needed.
- The following materials not found in the kit can also be used to repair squeaks and rattles.
 - SILICONE GREASE: Use instead of UHMW tape that will be visible or does not fit. The silicone grease will only last a few months.
 - SILICONE SPRAY: Use when grease cannot be applied.
 - DUCT TAPE: Use to eliminate movement.

CONFIRM THE REPAIR

Confirm that the cause of a noise is repaired by test driving the vehicle. Operate the vehicle under the same conditions as when the noise originally occurred. Refer to the notes on the Diagnostic Worksheet.

Generic Squeak and Rattle Troubleshooting

INFOID:000000011241619

Refer to Table of Contents for specific component removal and installation information.

SQUEAK AND RATTLE TROUBLE DIAGNOSES

< SYMPTOM DIAGNOSIS >

INSTRUMENT PANEL

Most incidents are caused by contact and movement between:

1. Cluster lid A and the instrument panel
2. Acrylic lens and combination meter housing
3. Instrument panel to front pillar finisher
4. Instrument panel to windshield
5. Instrument panel pins
6. Wiring harnesses behind the combination meter
7. A/C defroster duct and duct joint

These incidents can usually be located by tapping or moving the components to duplicate the noise or by pressing on the components while driving to stop the noise. Most of these incidents can be repaired by applying felt cloth tape or silicone spray (in hard to reach areas). Urethane pads can be used to insulate wiring harness.

CAUTION:

Do not use silicone spray to isolate a squeak or rattle. If you saturate the area with silicone, you will not be able to recheck the repair.

CENTER CONSOLE

Components to pay attention to include:

1. Shift selector assembly cover to finisher
2. A/C control unit and cluster lid C
3. Wiring harnesses behind audio and A/C control unit

The instrument panel repair and isolation procedures also apply to the center console.

DOORS

Pay attention to the:

1. Finisher and inner panel making a slapping noise
2. Inside handle escutcheon to door finisher
3. Wiring harnesses tapping
4. Door striker out of alignment causing a popping noise on starts and stops

Tapping or moving the components or pressing on them while driving to duplicate the conditions can isolate many of these incidents. You can usually insulate the areas with felt cloth tape or insulator foam blocks from the NISSAN Squeak and Rattle Kit (J-50397) to repair the noise.

TRUNK

Trunk noises are often caused by a loose jack or loose items put into the trunk by the owner.

In addition look for:

1. Trunk lid bumpers out of adjustment
2. Trunk lid striker out of adjustment
3. The trunk lid torsion bars knocking together
4. A loose license plate or bracket

Most of these incidents can be repaired by adjusting, securing or insulating the item(s) or component(s) causing the noise.

SUNROOF/HEADLINING

Noises in the sunroof/headlining area can often be traced to one of the following:

1. Sunroof lid, rail, linkage or seals making a rattle or light knocking noise
2. Sun visor shaft shaking in the holder
3. Front or rear windshield touching headlining and squeaking

Again, pressing on the components to stop the noise while duplicating the conditions can isolate most of these incidents. Repairs usually consist of insulating with felt cloth tape.

OVERHEAD CONSOLE (FRONT AND REAR)

Overhead console noises are often caused by the console panel clips not being engaged correctly. Most of these incidents are repaired by pushing up on the console at the clip locations until the clips engage.

In addition look for:

SQUEAK AND RATTLE TROUBLE DIAGNOSES

< SYMPTOM DIAGNOSIS >

1. Loose harness or harness connectors.
2. Front console map/reading lamp lens loose.
3. Loose screws at console attachment points.

A

SEATS

When isolating seat noise it's important to note the position the seat is in and the load placed on the seat when the noise is present. These conditions should be duplicated when verifying and isolating the cause of the noise.

B

Cause of seat noise include:

C

1. Headrest rods and holder
2. A squeak between the seat pad cushion and frame
3. The rear seatback lock and bracket

D

These noises can be isolated by moving or pressing on the suspected components while duplicating the conditions under which the noise occurs. Most of these incidents can be repaired by repositioning the component or applying urethane tape to the contact area.

E

UNDERHOOD

Some interior noise may be caused by components under the hood or on the engine wall. The noise is then transmitted into the passenger compartment.

F

Causes of transmitted underhood noise include:

1. Any component installed to the engine wall
2. Components that pass through the engine wall
3. Engine wall mounts and connectors
4. Loose radiator installation pins
5. Hood bumpers out of adjustment
6. Hood striker out of adjustment

G

H

These noises can be difficult to isolate since they cannot be reached from the interior of the vehicle. The best method is to secure, move or insulate one component at a time and test drive the vehicle. Also, engine rpm or load can be changed to isolate the noise. Repairs can usually be made by moving, adjusting, securing, or insulating the component causing the noise.

I

J

EXT

L

M

N

O

P

SQUEAK AND RATTLE TROUBLE DIAGNOSES

< SYMPTOM DIAGNOSIS >

Diagnostic Worksheet

INFOID:000000011241620

Dear Customer:

We are concerned about your satisfaction with your vehicle. Repairing a squeak or rattle sometimes can be very difficult. To help us fix your vehicle right the first time, please take a moment to note the area of the vehicle where the squeak or rattle occurs and under what conditions. You may be asked to take a test drive with a service advisor or technician to ensure we confirm the noise you are hearing.

SQUEAK & RATTLE DIAGNOSTIC WORKSHEET

I. WHERE DOES THE NOISE COME FROM? (circle the area of the vehicle)

The illustrations are for reference only, and may not reflect the actual configuration of your vehicle.

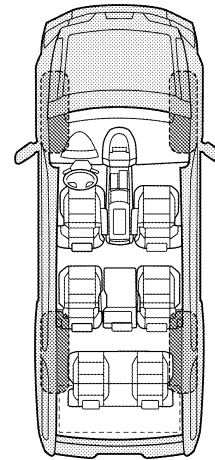
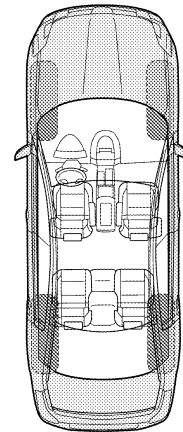

Continue to page 2 of the worksheet and briefly describe the location of the noise or rattle. In addition, please indicate the conditions which are present when the noise occurs.

SQUEAK AND RATTLE TROUBLE DIAGNOSES

< SYMPTOM DIAGNOSIS >

SQUEAK & RATTLE DIAGNOSTIC WORKSHEET - page 2

Briefly describe the location where the noise occurs:

II. WHEN DOES IT OCCUR? (please check the boxes that apply)

- | | |
|---|--|
| <input type="checkbox"/> Anytime | <input type="checkbox"/> After sitting out in the rain |
| <input type="checkbox"/> 1st time in the morning | <input type="checkbox"/> When it is raining or wet |
| <input type="checkbox"/> Only when it is cold outside | <input type="checkbox"/> Dry or dusty conditions |
| <input type="checkbox"/> Only when it is hot outside | <input type="checkbox"/> Other: |

III. WHEN DRIVING:

- Through driveways
- Over rough roads
- Over speed bumps
- Only about ____ mph
- On acceleration
- Coming to a stop
- On turns: left, right or either (circle)
- With passengers or cargo
- Other: _____
- After driving ____ miles or ____ minutes

IV. WHAT TYPE OF NOISE

- Squeak (like tennis shoes on a clean floor)
- Creak (like walking on an old wooden floor)
- Rattle (like shaking a baby rattle)
- Knock (like a knock at the door)
- Tick (like a clock second hand)
- Thump (heavy muffled knock noise)
- Buzz (like a bumble bee)

TO BE COMPLETED BY DEALERSHIP PERSONNEL

Test Drive Notes:

| | YES | NO | Initials of person performing |
|--|--------------------------|--------------------------|-------------------------------|
| Vehicle test driven with customer | <input type="checkbox"/> | <input type="checkbox"/> | _____ |
| - Noise verified on test drive | <input type="checkbox"/> | <input type="checkbox"/> | _____ |
| - Noise source located and repaired | <input type="checkbox"/> | <input type="checkbox"/> | _____ |
| - Follow up test drive performed to confirm repair | <input type="checkbox"/> | <input type="checkbox"/> | _____ |

VIN: _____ Customer Name _____

W.O.# _____ Date: _____

This form must be attached to Work Order

LATA0071E

EXT

A
B
C
D
E
F
G
H
I
J
L
M
N
O
P

FRONT BUMPER

< REMOVAL AND INSTALLATION >

REMOVAL AND INSTALLATION

FRONT BUMPER

Exploded View

INFOID:000000011241621

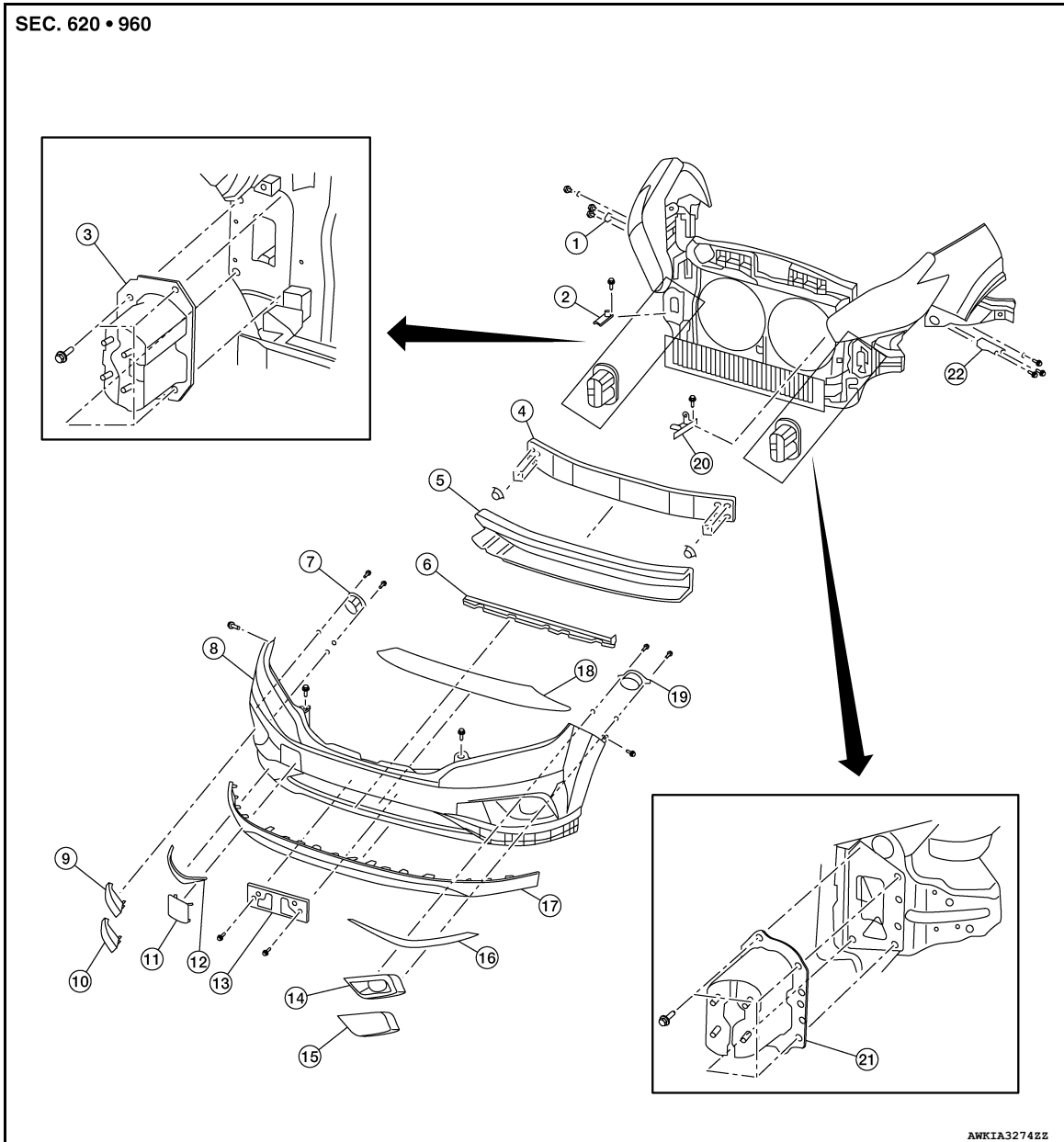

- | | | |
|--|--|--|
| 1. Front bumper fascia side bracket (RH) | 2. Front bumper side retainer (RH) | 3. Front bumper reinforcement bracket (RH) |
| 4. Front bumper reinforcement | 5. Front energy absorber | 6. Front bumper air guide |
| 7. Front fog lamp (RH) (if equipped) | 8. Front bumper fascia | 9. Front fog lamp finisher (RH) (if equipped) |
| 10. Front bumper fascia finisher (RH) (without fog lamp) | 11. Tow cover | 12. Front bumper fascia molding (RH) |
| 13. Front license plate bracket | 14. Front fog lamp finisher (LH) (if equipped) | 15. Front bumper fascia finisher (LH) (without fog lamp) |
| 16. Front bumper fascia molding (LH) | 17. Front spoiler | 18. Front bumper lower grille |

FRONT BUMPER

< REMOVAL AND INSTALLATION >

- | | | |
|---|-------------------------------------|---|
| 19. Front fog lamp (LH) (if equipped) | 20. Front bumper side retainer (LH) | 21. Front bumper reinforcement bracket (LH) |
| 22. Front bumper fascia side bracket (LH) | | |

Removal and Installation

INFOID:000000011241622

CAUTION:

Bumper fascia is made of resin. Use care when handling to prevent damage. Avoid contact with oily substances.

REMOVAL

1. Remove the front grille. Refer to [EXT-30. "Removal and Installation"](#).
2. Remove the front bumper fascia clips (A).

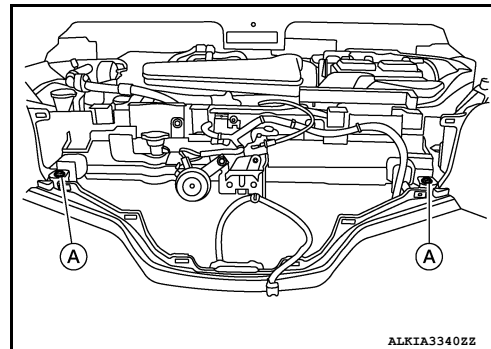

3. Partially remove front over fender (LH/RH). Refer to [EXT-38. "FRONT OVER FENDER : Exploded View"](#).
4. Partially remove front fender protector (LH/RH). Refer to [EXT-36. "FENDER PROTECTOR : Exploded View"](#).
5. Remove the front bumper fascia screws (A) (LH/RH).
(1): Front bumper fascia
(2): Front over fender

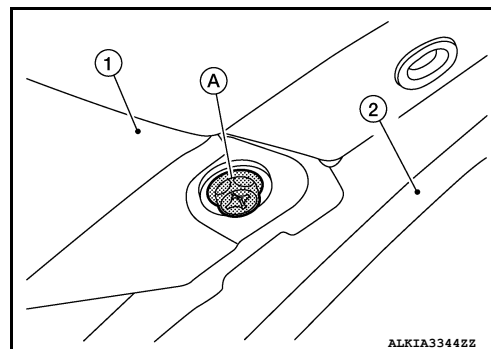

6. Disconnect fog lamp harness connector (LH/RH) (if equipped).
7. Release front bumper fascia pawls from front bumper fascia side bracket (LH/RH) and remove.
CAUTION:
When removing front bumper fascia, two people are required to avoid damaging.
8. Remove front bumper side bracket bolts and the front bumper side bracket (LH/RH) (if necessary).
9. Remove the front energy absorber (if necessary).
10. Remove front bumper reinforcement nuts and front bumper reinforcement (if necessary).
11. Remove front bumper reinforcement support bolts and front bumper reinforcement support (LH/RH) (if necessary).

INSTALLATION

Installation is in the reverse order of removal.

NOTE:

- The following table shows the specified values for checking normal installation specifications.
- Fitting adjustment cannot be performed.

FRONT BUMPER

< REMOVAL AND INSTALLATION >

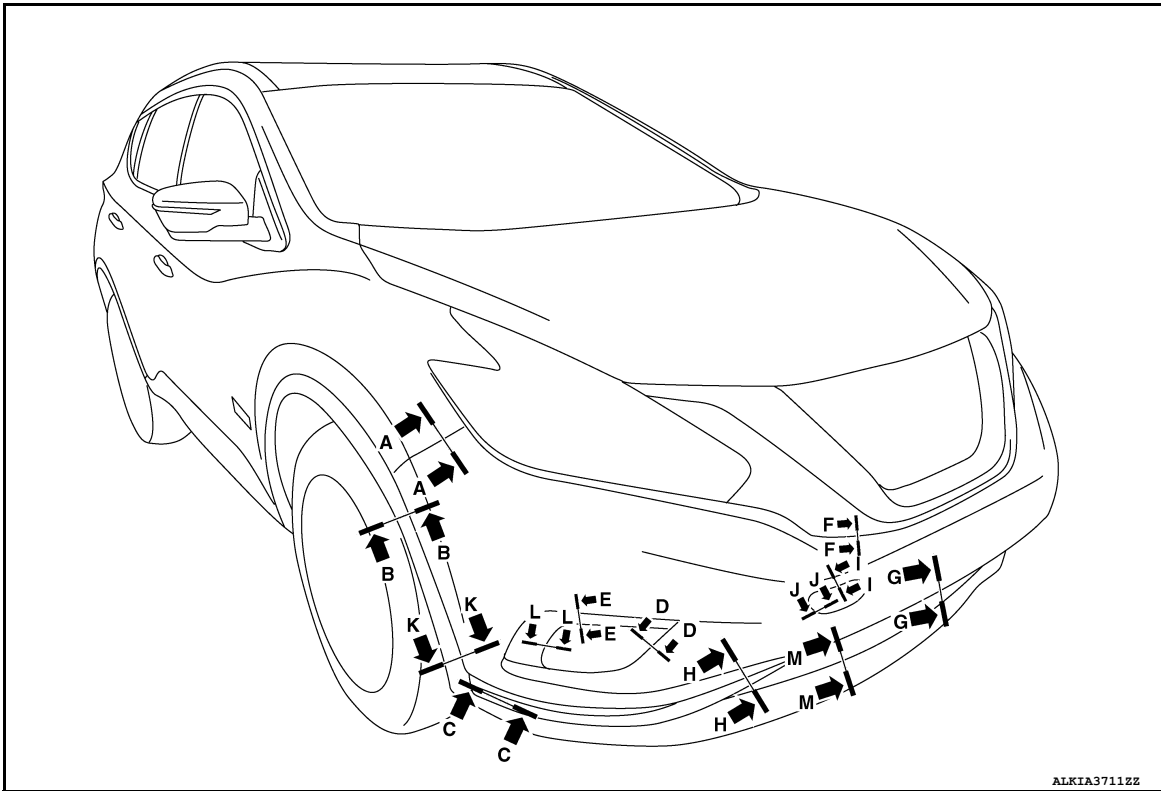

ALKIA3711ZZ

| Section | Measurement | Minimum | Target Value | Maximum |
|---------|----------------|--------------|--------------|------------|
| A-A | Clearance | 0.0 (0.00) | 0.3 (0.01) | 1.0 (0.04) |
| | Surface height | -0.1 (0.00) | 0.7 (0.03) | 1.5 (0.06) |
| B-B | Clearance | 0.0 (0.00) | 0.5 (0.02) | 1.4 (0.06) |
| C-C | Clearance | 0.7 (0.03) | 2.0 (0.08) | 3.3 (0.13) |
| D-D | Clearance | 0.1 (0.00) | 1.0 (0.04) | 1.9 (0.07) |
| E-E | Clearance | 0.1 (0.00) | 1.0 (0.04) | 1.9 (0.07) |
| F-F | Clearance | 0.5 (0.02) | 1.5 (0.06) | 2.5 (0.10) |
| G-G | Clearance | 0.0 (0.00) | 1.0 (0.04) | 2.0 (0.08) |
| H-H | Clearance | 0.5 (0.02) | 1.5 (0.06) | 2.5 (0.10) |
| I-I | Clearance | 0.0 (0.00) | 0.5 (0.02) | 1.0 (0.04) |
| | Surface height | -0.2 (-0.01) | 0.3 (0.01) | 0.8 (0.03) |
| J-J | Clearance | 0.0 (0.00) | 0.5 (0.02) | 1.0 (0.04) |
| | Surface height | -0.2 (-0.01) | 0.3 (0.01) | 0.8 (0.03) |
| K-K | Clearance | 0.0 (0.00) | 0.5 (0.02) | 1.5 (0.06) |
| | Surface height | -1.0 (-0.04) | 0.0 (0.00) | 1.0 (0.04) |
| L-L | Clearance | 0.2 (0.01) | 2.0 (0.08) | 3.8 (0.15) |
| M-M | Clearance | 0.0 (0.00) | 0.3 (0.01) | 1.3 (0.05) |

REAR BUMPER

< REMOVAL AND INSTALLATION >

REAR BUMPER

Exploded View

INFOID:000000011241623

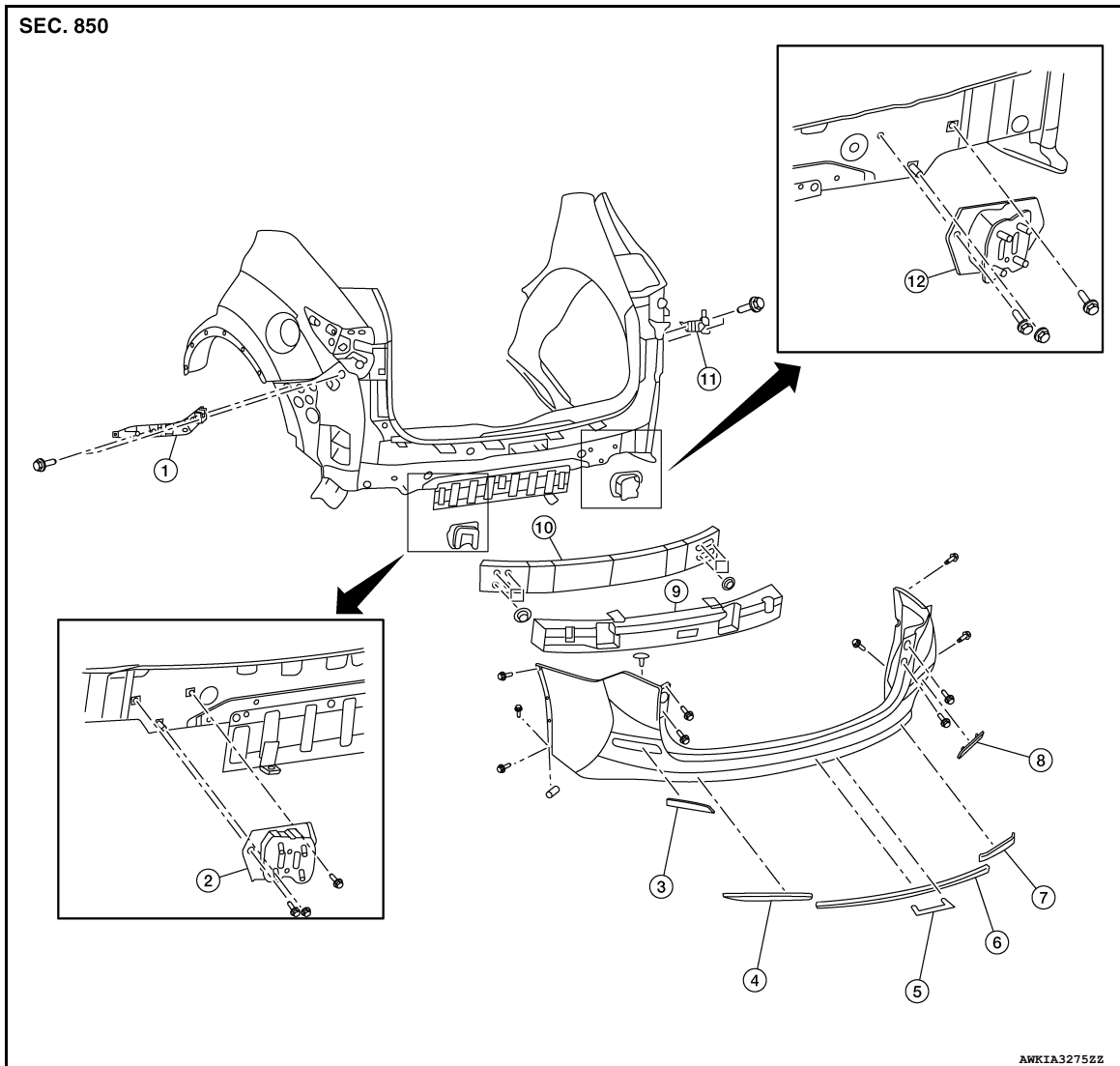

- | | | |
|---|--|--|
| 1. Rear bumper fascia side bracket (LH) | 2. Rear bumper reinforcement support (LH) | 3. Rear bumper fascia reflector (LH) |
| 4. Rear bumper fascia molding (LH) | 5. Rear bumper fascia finisher | 6. Rear bumper fascia molding center |
| 7. Rear bumper fascia molding (RH) | 8. Rear bumper fascia reflector (RH) | 9. Rear energy absorber |
| 10. Rear bumper reinforcement | 11. Rear bumper reinforcement support (RH) | 12. Rear bumper fascia side bracket (RH) |

Removal and Installation

INFOID:000000011241624

CAUTION:

Bumper fascia is made of resin. Use care when handling to prevent damage. Avoid contact with oily substances.

REMOVAL

1. Remove rear combination lamps (LH/RH). Refer to [EXL-136, "Removal and Installation"](#) (LED HEAD-LAMP) or [EXL-269, "Removal and Installation"](#) (HALOGEN TYPE).
2. Partially remove rear over fender (LH/RH). Refer to [EXT-39, "REAR OVER FENDER : Exploded View"](#).

A
B
C
D
E
F
G
H
I
J
K
L
M
N
O
P

EXT

REAR BUMPER

< REMOVAL AND INSTALLATION >

3. Partially remove rear wheel house protector (LH/RH). Refer to [EXT-37, "REAR WHEEL HOUSE PROTECTOR : Exploded View"](#).
4. Remove rear bumper fascia upper screws.
5. Remove rear bumper fascia screw (A) (LH/RH).

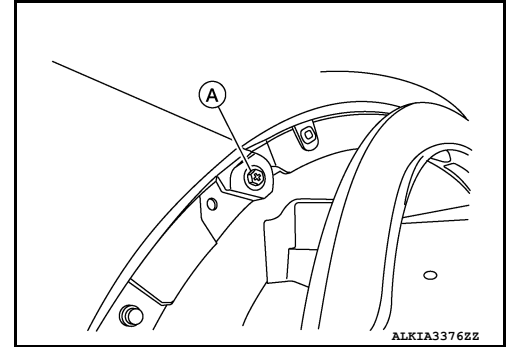

6. Release rear bumper pawls from the rear bumper fascia side bracket (LH/RH) and remove.
CAUTION:
When removing rear bumper fascia, two people are required to avoid damaging.
7. Remove rear energy absorber (if necessary).
8. Remove rear bumper reinforcement nuts (LH/RH) then remove rear bumper reinforcement (if necessary).
9. Remove rear bumper reinforcement support bolts (LH/RH) then remove rear bumper reinforcement support (LH/RH) (if necessary).

INSTALLATION

Installation is in the reverse order of removal.

NOTE:

- The following table shows the specified values for checking normal installation specifications.
- Fitting adjustment cannot be performed.

REAR BUMPER

< REMOVAL AND INSTALLATION >

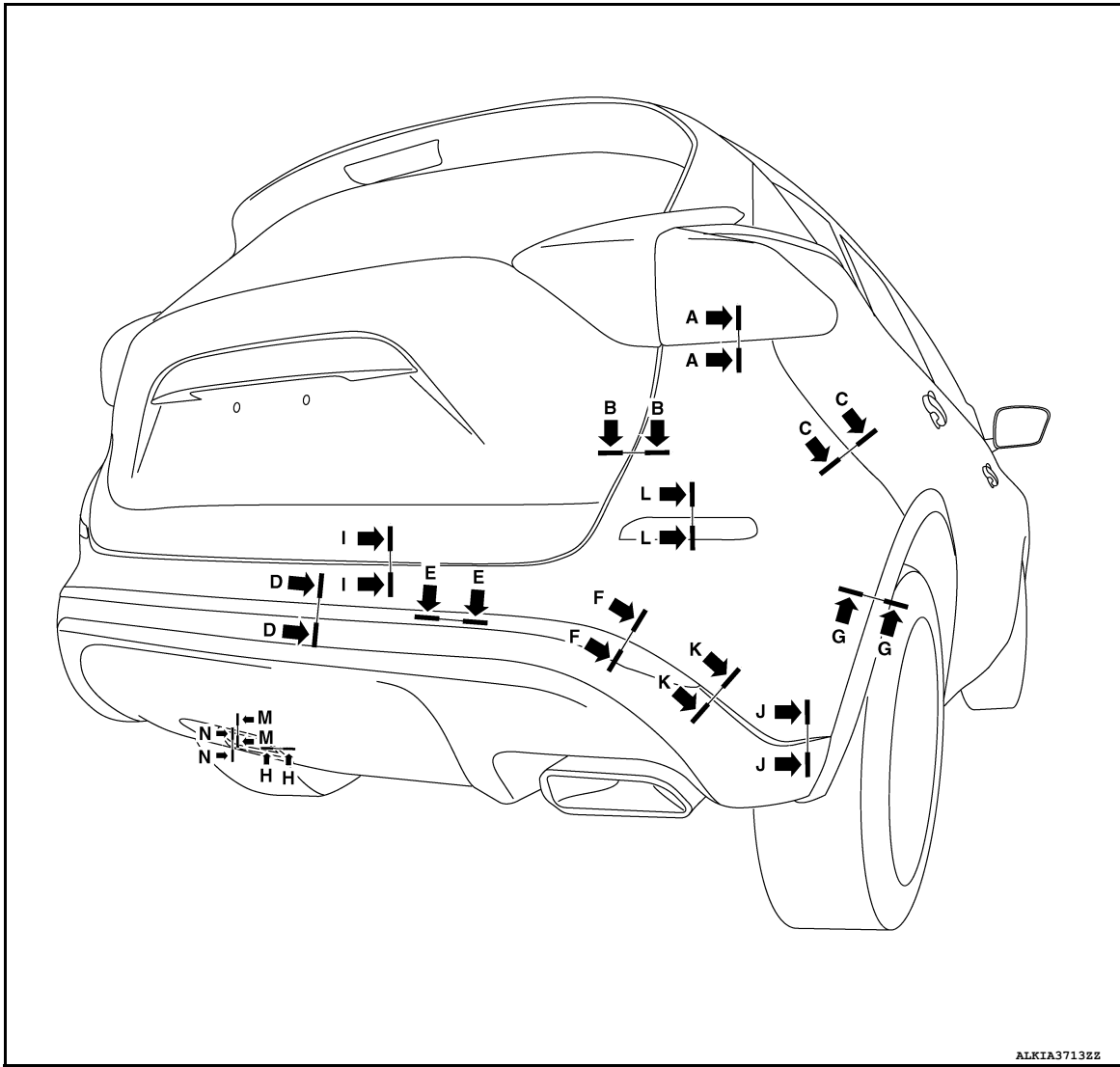

ALKIA3713ZZ

| Section | Measurement | Minimum | Target Value | Maximum |
|---------|----------------|---------------|--------------|------------|
| A-A | Clearance | 0.1 (0.004) | 1.5 (0.06) | 2.9 (0.11) |
| B-B | Clearance | 4.1 (0.16) | 6.0 (0.24) | 7.9 (0.31) |
| | Surface height | -1.4 (-0.06) | 0.5 (0.02) | 2.4 (0.09) |
| C-C | Clearance | 0.0 (0.00) | 0.3 (0.01) | 1.0 (0.04) |
| | Surface height | -0.1 (-0.004) | 0.7 (0.03) | 1.5 (0.06) |
| D-D | Clearance | 0.0 (0.00) | 1.0 (0.04) | 2.0 (0.08) |
| E-E | Clearance | 0.1 (0.004) | 1.2 (0.05) | 3.3 (0.13) |
| | Surface height | -1.0 (-0.04) | 0.0 (0.00) | 1.0 (0.04) |
| F-F | Clearance | 0.0 (0.00) | 1.0 (0.04) | 2.0 (0.08) |
| G-G | Clearance | 0.0 (0.00) | 0.5 (0.02) | 1.5 (0.06) |
| H-H | Clearance | 0.0 (0.00) | 1.0 (0.04) | 2.0 (0.08) |
| I-I | Clearance | 6.1 (0.24) | 8.0 (0.31) | 9.9 (0.39) |
| J-J | Clearance | 0.0 (0.00) | 0.0 (0.00) | 0.7 (0.03) |
| K-K | Clearance | 0.3 (0.01) | 1.0 (0.04) | 1.7 (0.07) |
| L-L | Clearance | 0.5 (0.02) | 1.5 (0.06) | 2.5 (0.10) |
| M-M | Clearance | 0.0 (0.00) | 1.0 (0.04) | 2.5 (0.10) |
| N-N | Clearance | 0.0 (0.00) | 1.0 (0.04) | 2.0 (0.08) |

A
B
C
D
E
F
G
H
I
J

EXT

L
M
N
O
P

FRONT GRILLE

< REMOVAL AND INSTALLATION >

FRONT GRILLE

Exploded View

INFOID:000000011241625

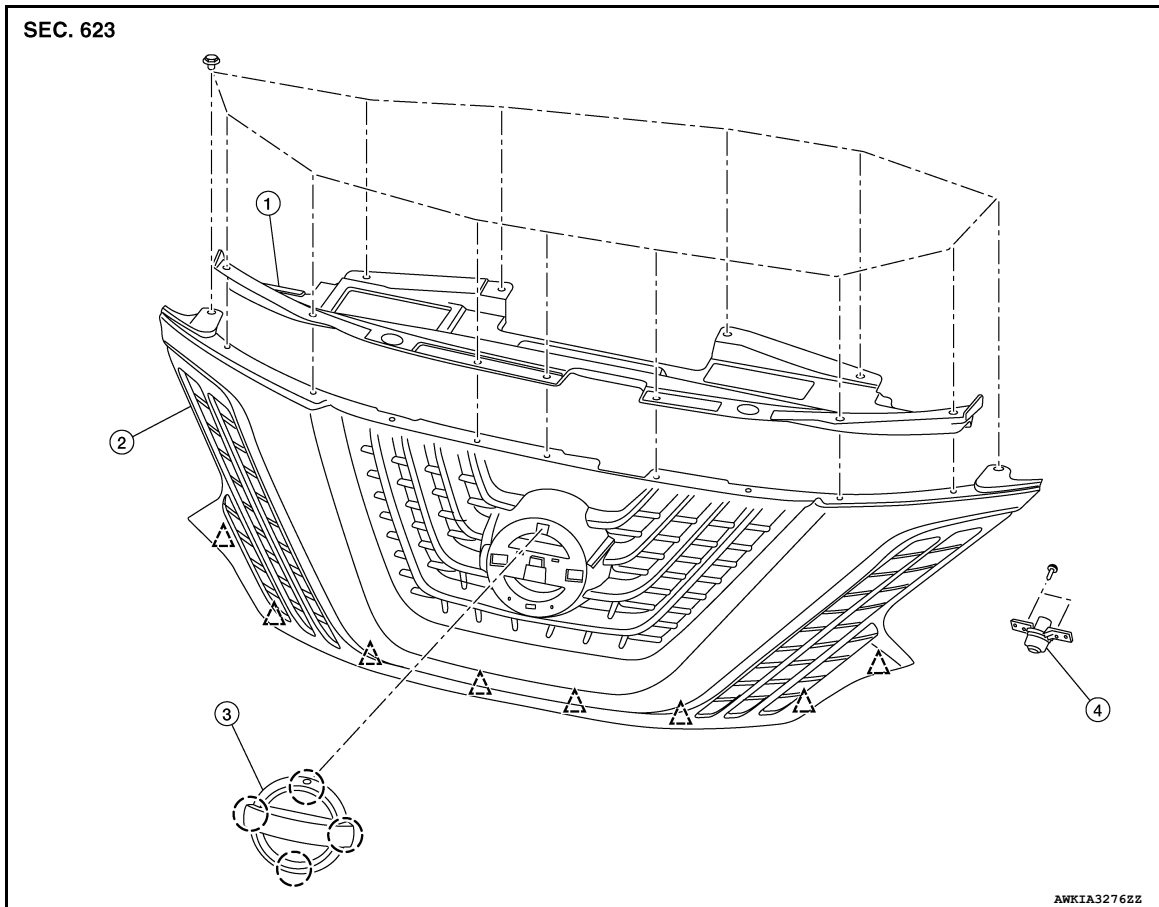

- | | | |
|-------------------------------|-----------------|-----------------|
| 1. Core support cover | 2. Front grille | 3. Front emblem |
| 4. Front camera (if equipped) | △ Clip | ○ Pawl |

Removal and Installation

INFOID:000000011241626

REMOVAL

1. Remove the core support cover.
2. Release hood switch harness clip from upper radiator air guide and disconnect harness connector from hood switch.
3. Disconnect overflow hose and remove upper radiator air guide.
4. Release clips then remove front grille.
5. Disconnect the harness connector (A) from the front camera (if equipped).

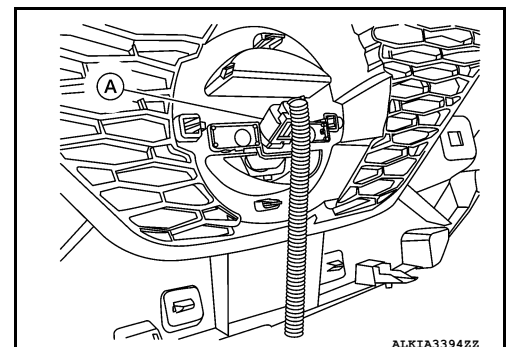

FRONT GRILLE

< REMOVAL AND INSTALLATION >

INSTALLATION

Installation is in the reverse order of removal.

A

B

C

D

E

F

G

H

I

J

EXT

L

M

N

O

P

ACTIVE GRILLE SHUTTER

< REMOVAL AND INSTALLATION >

ACTIVE GRILLE SHUTTER

Exploded View

INFOID:000000011241627

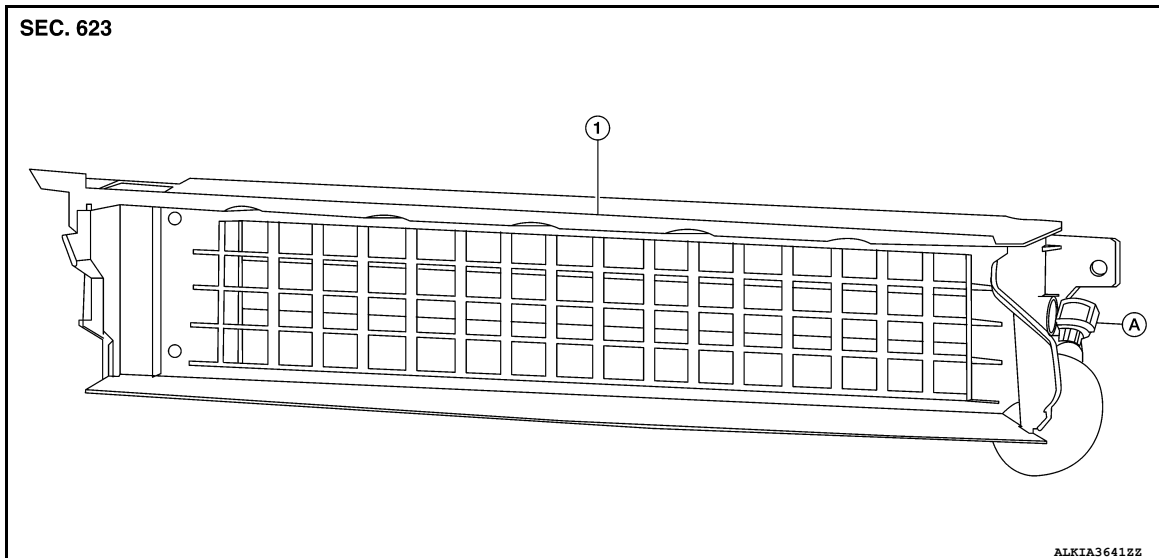

1. Active grille shutter

A. Active grille shutter harness connector

Removal and Installation

INFOID:000000011241628

REMOVAL

1. Remove the front bumper fascia. Refer to [EXT-25, "Removal and Installation"](#).
2. Remove the active grille shutter bolts (B).
3. Release active grille shutter harness clips using a suitable tool.
4. Disconnect the harness connector (A) from the active grille shutter (1).

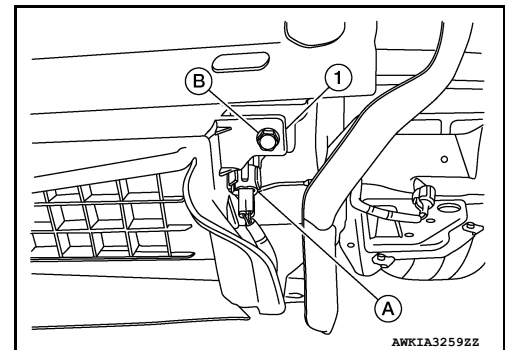

INSTALLATION

Installation is in the reverse order of removal.

FRONT SPOILER

< REMOVAL AND INSTALLATION >

FRONT SPOILER

Exploded View

INFOID:000000011241629

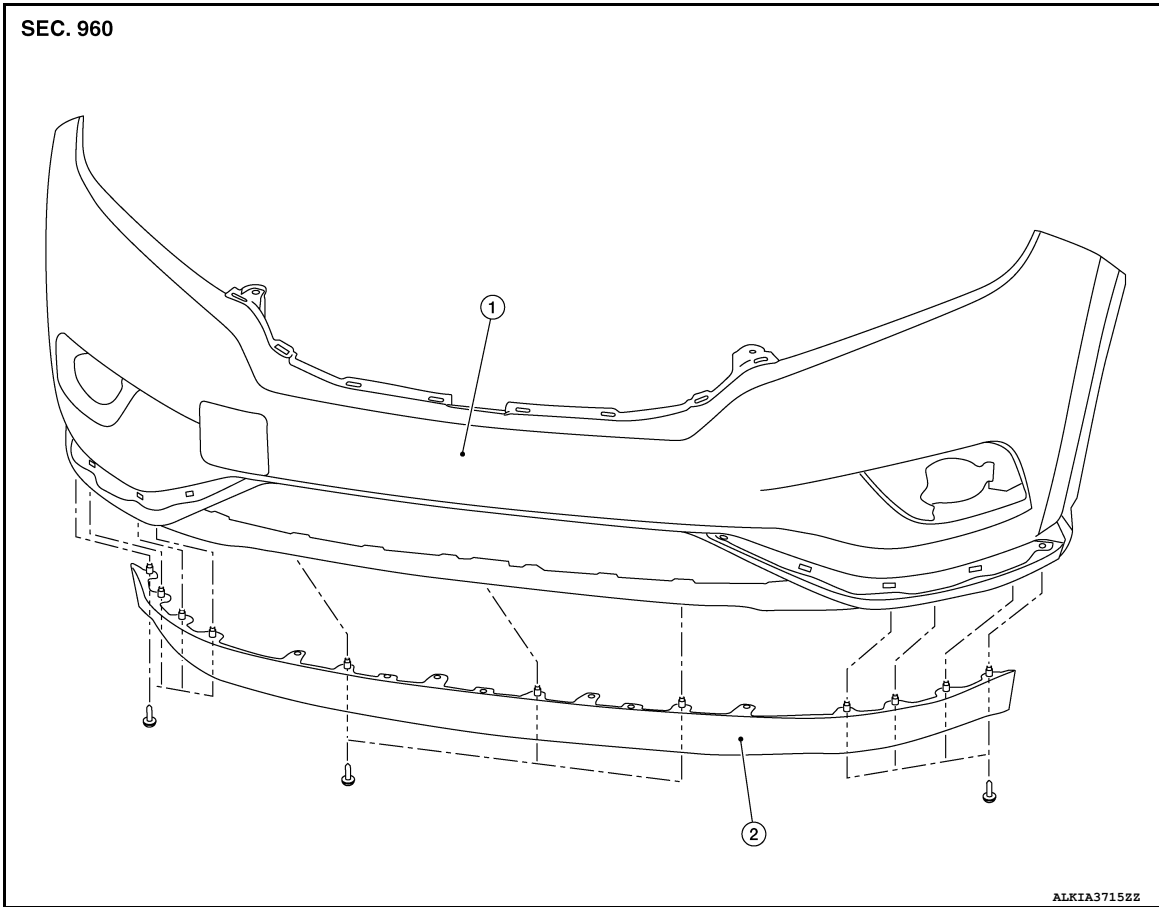

1. Front bumper fascia

2. Front air spoiler

Removal and Installation

INFOID:000000011241630

REMOVAL

Remove front spoiler clips and remove.

INSTALLATION

Installation is in the reverse order of removal.

A
B
C
D
E
F
G
H
I
J

EXT

L
M
N
O
P

COWL TOP

< REMOVAL AND INSTALLATION >

COWL TOP

Exploded View

INFOID:000000011241631

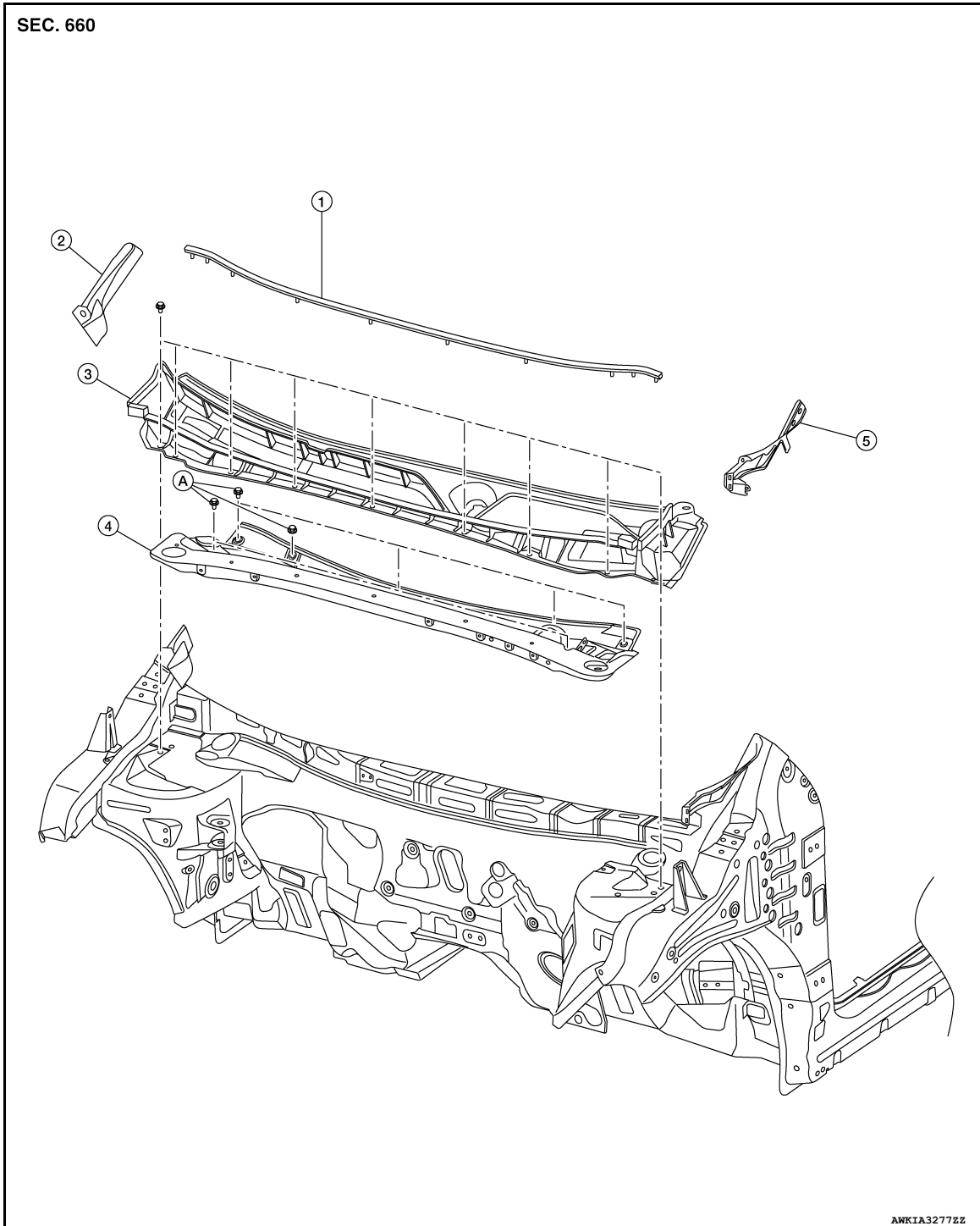

- | | | |
|------------------------|----------------------------------|--------------------------|
| 1. Cowl top cover seal | 2. Cowl top side trim cover (RH) | 3. Cowl top cover |
| 4. Cowl top extension | 5. Cowl top side trim cover (LH) | A. Refer to INSTALLATION |

Removal and Installation - Cowl Top Cover

INFOID:000000011241632

REMOVAL

1. Remove front wiper arms (LH/RH). Refer to [WW-62. "Removal and Installation"](#).

COWL TOP

< REMOVAL AND INSTALLATION >

2. Remove cowl top side trim covers (LH/RH).
3. Remove cowl top cover clips.
4. Remove the cowl top cover (1) as shown.

CAUTION:

When performing the procedure after removing cowl top cover, cover the lower end of windshield with urethane, etc, to prevent damage to the windshield.

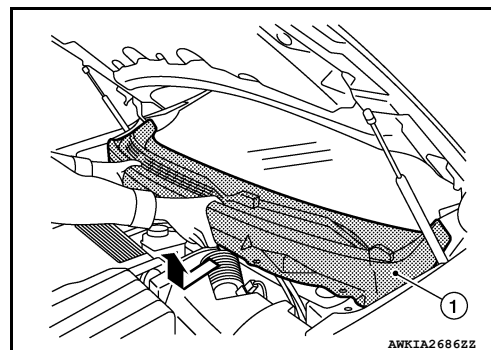

INSTALLATION

Installation is in the reverse order of removal.

Removal and Installation - Cowl Top Extension

INFOID:000000011560452

REMOVAL

1. Remove front wiper drive assembly. Refer to [WW-68, "Removal and Installation"](#).
2. Disconnect brake fluid level sensor harness connector from brake fluid level sensor.
3. Remove sub tank and sub tank bracket from cowl top extension and set aside. Refer to [BR-32, "Exploded View"](#)
4. Remove cowl top extension bolts and remove.

INSTALLATION

Installation is in the reverse order of removal.

NOTE:

When installing the cowl top extension, tighten the bolts to specification in the order shown.

Cowl top extension bolts : 32 N·m (3.3 kg-m, 24 ft-lb)

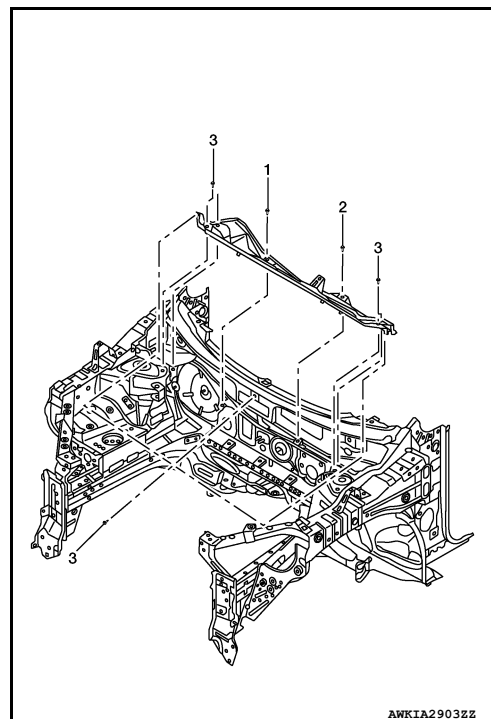

A
B
C
D
E
F
G
H
I
J
EXT
L
M
N
O
P

FENDER PROTECTOR

< REMOVAL AND INSTALLATION >

FENDER PROTECTOR

FENDER PROTECTOR

FENDER PROTECTOR : Exploded View

INFOID:000000011241633

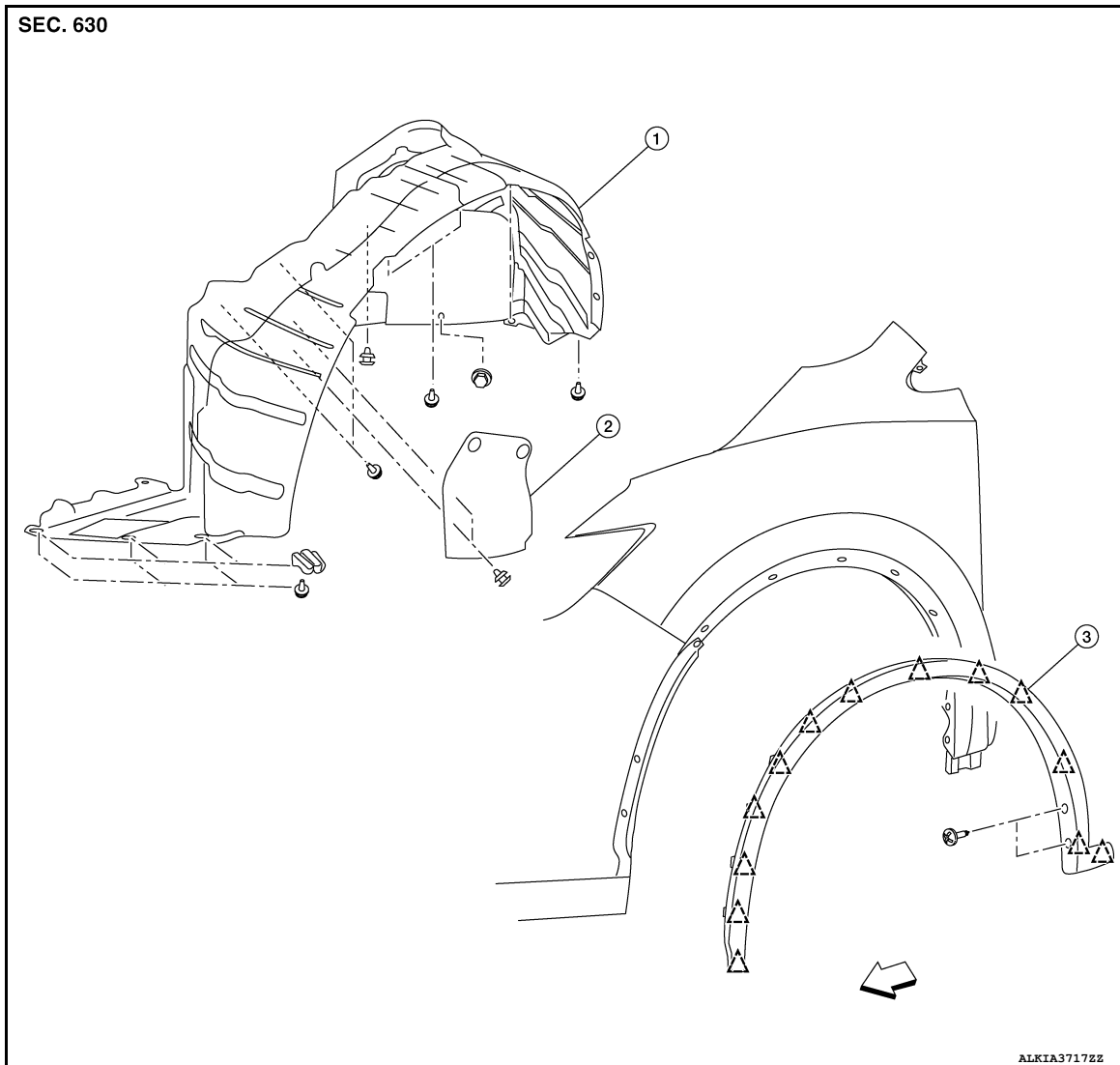

1. Front fender protector

2. Engine side cover

3. Front over fender

△ : Clip

⇨ : Front

FENDER PROTECTOR : Removal and Installation

INFOID:000000011560050

REMOVAL

1. Position the front wheels as necessary to remove screws and clips.
2. Remove front over fender. Refer to [EXT-38, "FRONT OVER FENDER : Removal and Installation"](#).
3. Remove engine side cover.
4. Release front fender protector clips and remove front fender protector.

INSTALLATION

Installation is in the reverse order of removal.

REAR WHEEL HOUSE PROTECTOR

FENDER PROTECTOR

< REMOVAL AND INSTALLATION >

REAR WHEEL HOUSE PROTECTOR : Exploded View

INFOID:000000011560051

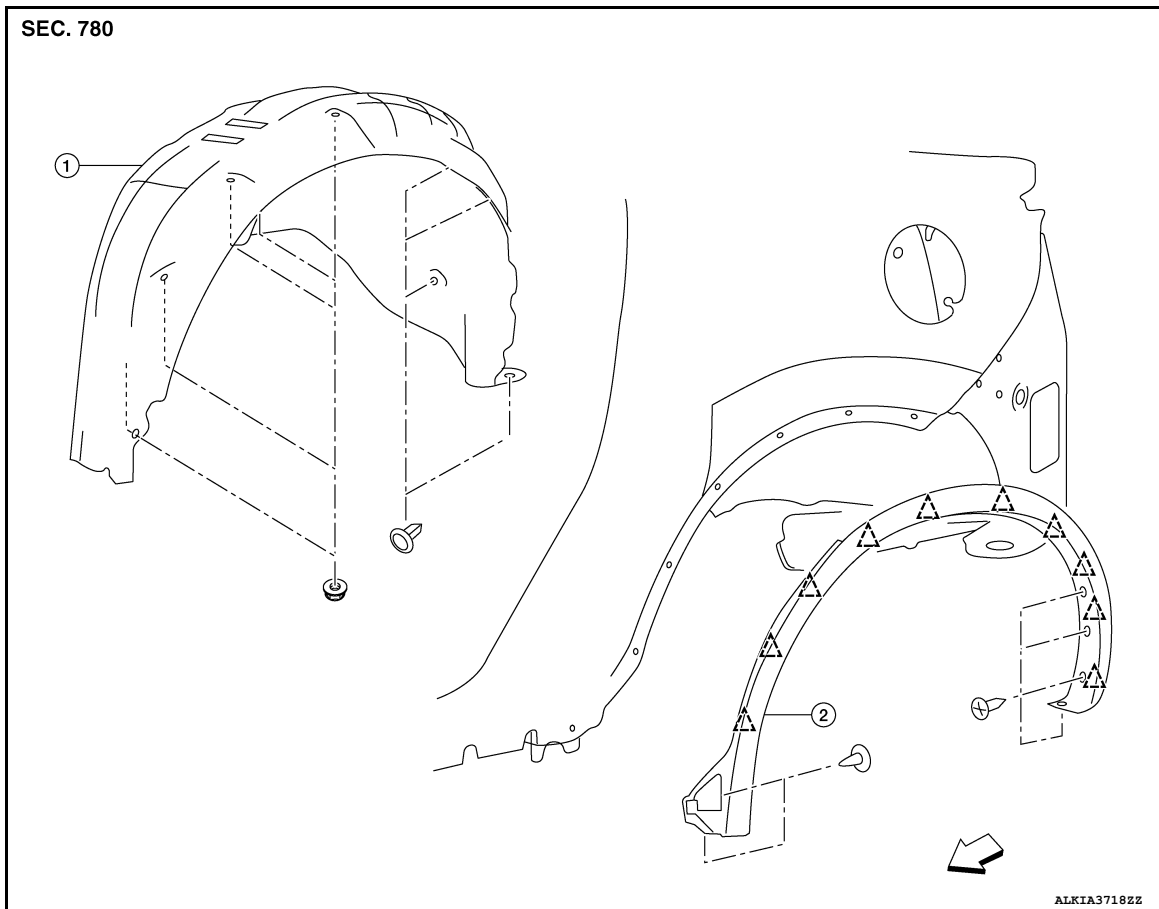

1. Rear wheel house protector

2. Rear over fender

△ : Clip

⇐ : Front

A
B
C
D
E
F
G
H
I
J

EXT

REAR WHEEL HOUSE PROTECTOR : Removal and Installation

INFOID:000000011560052

REMOVAL

1. Remove rear over fender. Refer to [EXT-39. "REAR OVER FENDER : Removal and Installation"](#).
2. Remove rear wheel house protector clips.
3. Remove rear wheel house protector nuts and rear wheel house protector.

INSTALLATION

Installation is in the reverse order of removal.

L
M
N
O
P

OVER FENDER

< REMOVAL AND INSTALLATION >

OVER FENDER

FRONT OVER FENDER

FRONT OVER FENDER : Exploded View

INFOID:000000011560053

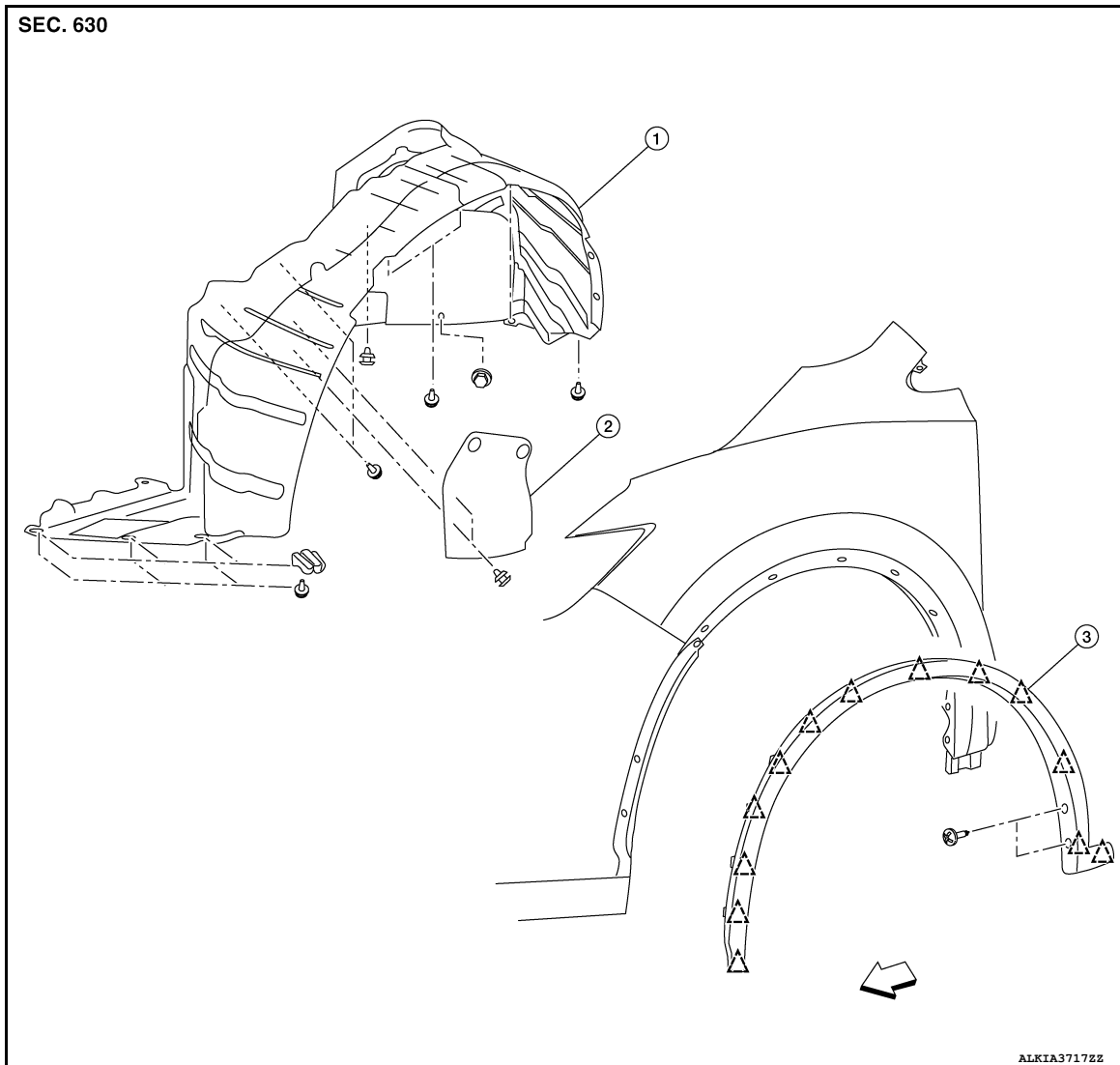

1. Front fender protector

2. Engine side cover

3. Front over fender

△ : Clip

⇐ : Front

FRONT OVER FENDER : Removal and Installation

INFOID:000000011560054

REMOVAL

1. Remove front and rear screws.
2. Release clips using suitable tool and remove.

INSTALLATION

Installation is in the reverse order of removal.

CAUTION:

- Visually check the clips for deformation and damage during installation. Replace with new ones if necessary.
- When installing front over fender, check that clips are securely placed in body panel holes.

REAR OVER FENDER

OVER FENDER

< REMOVAL AND INSTALLATION >

REAR OVER FENDER : Exploded View

INFOID:000000011560055

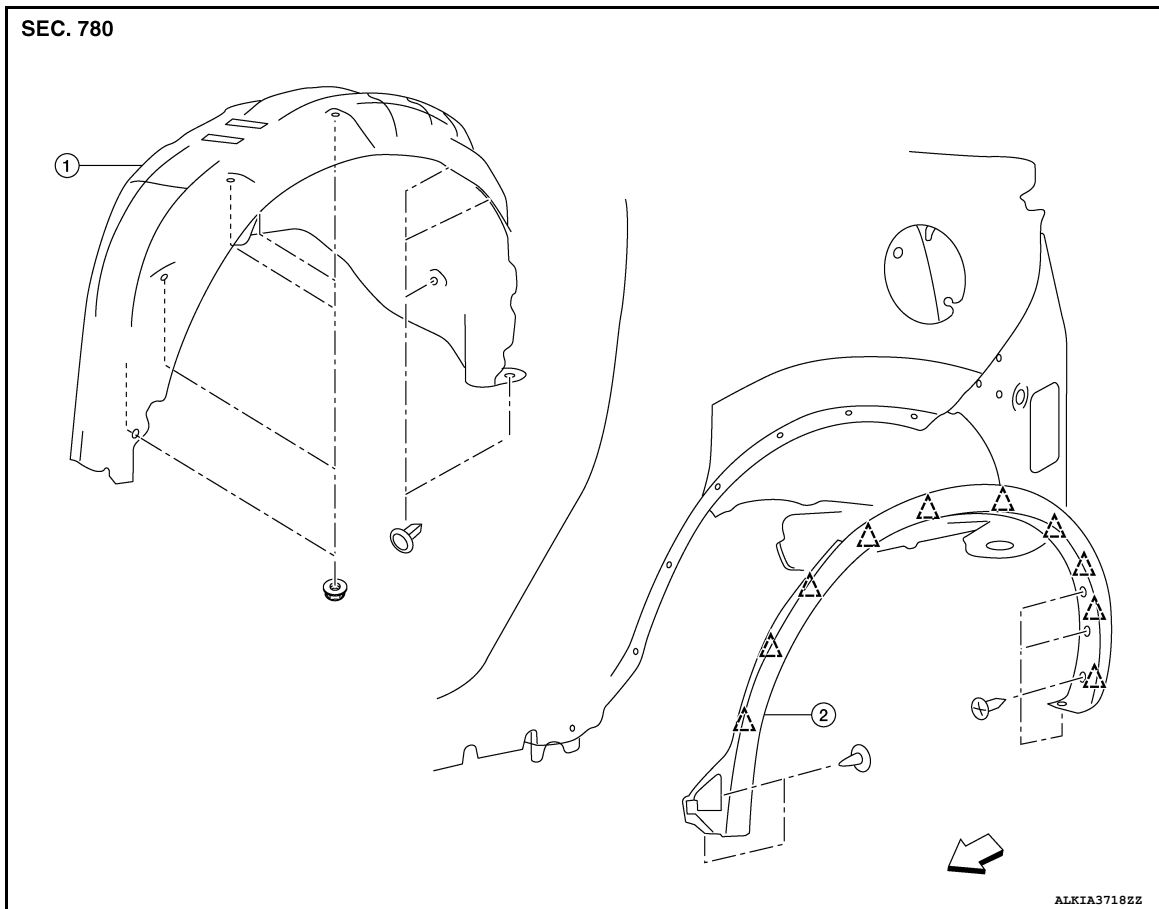

1. Rear wheel house protector

2. Rear over fender

△ : Clip

← : Front

A
B
C
D
E
F
G
H
I
J

EXT

REAR OVER FENDER : Removal and Installation

INFOID:000000011560056

REMOVAL

1. Remove rear over fender screws.
2. Release clips using suitable tool and remove.

INSTALLATION

Installation is in the reverse order of removal.

CAUTION:

- Visually check the clips for deformation and damage during installation. Replace with new ones if necessary.
- When installing over fender, check that clips are securely placed in body panel holes.

L
M
N
O
P

UNDER COVER

< REMOVAL AND INSTALLATION >

UNDER COVER

Exploded View

INFOID:000000011241637

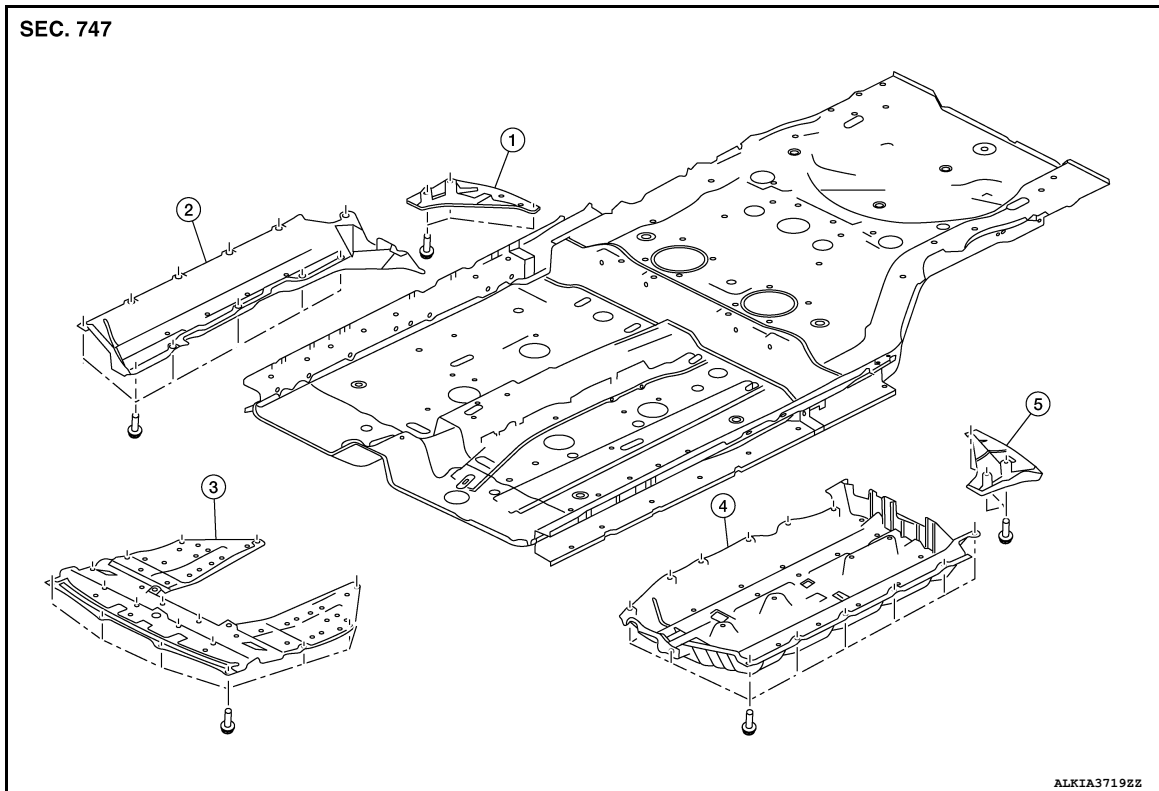

1. Rear under cover (RH)
2. Floor under cover (RH)
3. Front under cover
4. Floor under cover (LH)
5. Rear under cover (LH)

FRONT UNDER COVER

FRONT UNDER COVER : Removal and Installation

INFOID:000000011241636

REMOVAL

Remove the front under cover clips and remove.

INSTALLATION

Installation is in the reverse order of removal.

FLOOR UNDER COVER

FLOOR UNDER COVER : Removal and Installation

INFOID:000000011241638

REMOVAL

Remove the floor under cover bolts and remove.

INSTALLATION

Installation is in the reverse order of removal.

REAR UNDER COVER

REAR UNDER COVER : Removal and Installation

INFOID:000000011241639

REMOVAL

Remove the rear under cover screws and remove.

INSTALLATION

UNDER COVER

< REMOVAL AND INSTALLATION >

Installation is in the reverse order of removal.

A

B

C

D

E

F

G

H

I

J

EXT

L

M

N

O

P

ROOF SIDE MOLDING

< REMOVAL AND INSTALLATION >

ROOF SIDE MOLDING

Exploded View

INFOID:000000011241640

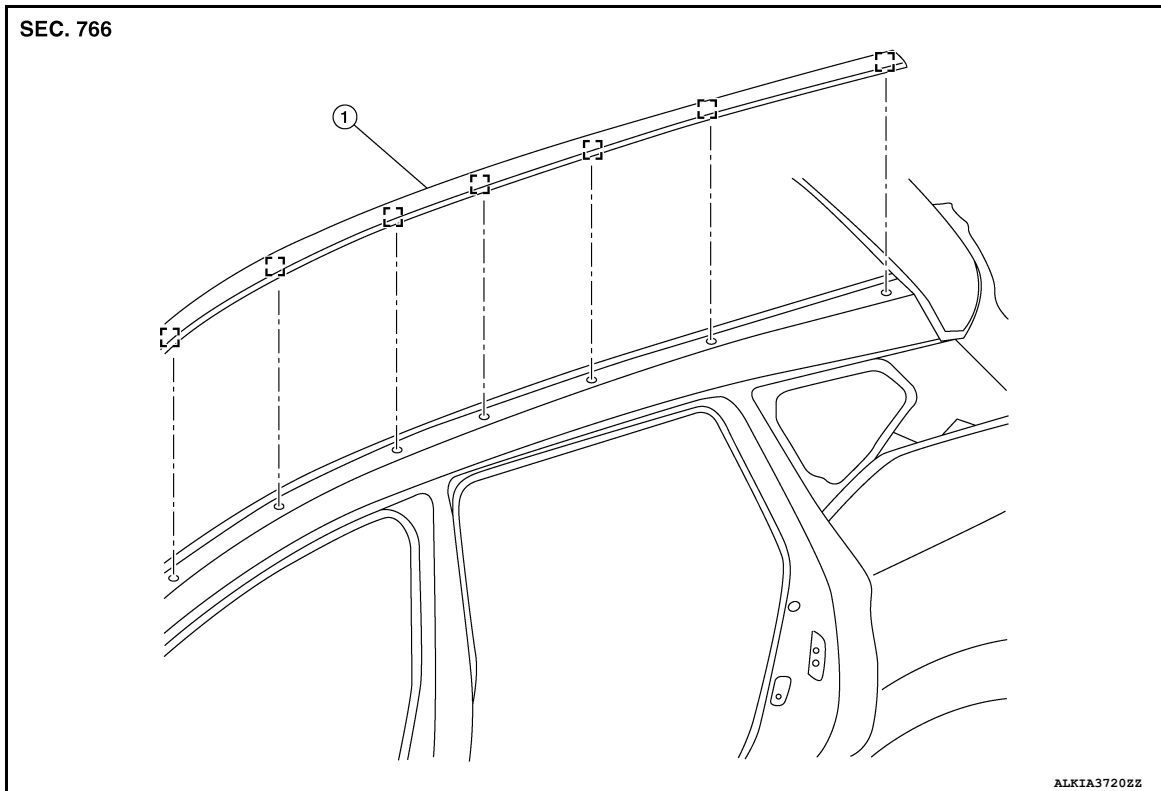

1. Roof side molding

[] : Metal clips

Removal and Installation

INFOID:000000011241641

REMOVAL

Beginning at the front of the vehicle, release roof side molding (1) metal clips using a suitable tool (A) then remove.

[]: Metal clip

CAUTION:

Apply protective tape (B) around the roof side molding.

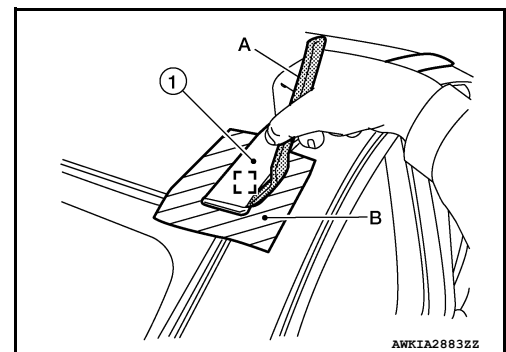

INSTALLATION

Installation is in the reverse order of removal.

ROOF RACK

< REMOVAL AND INSTALLATION >

ROOF RACK

Exploded View

INFOID:000000011560057

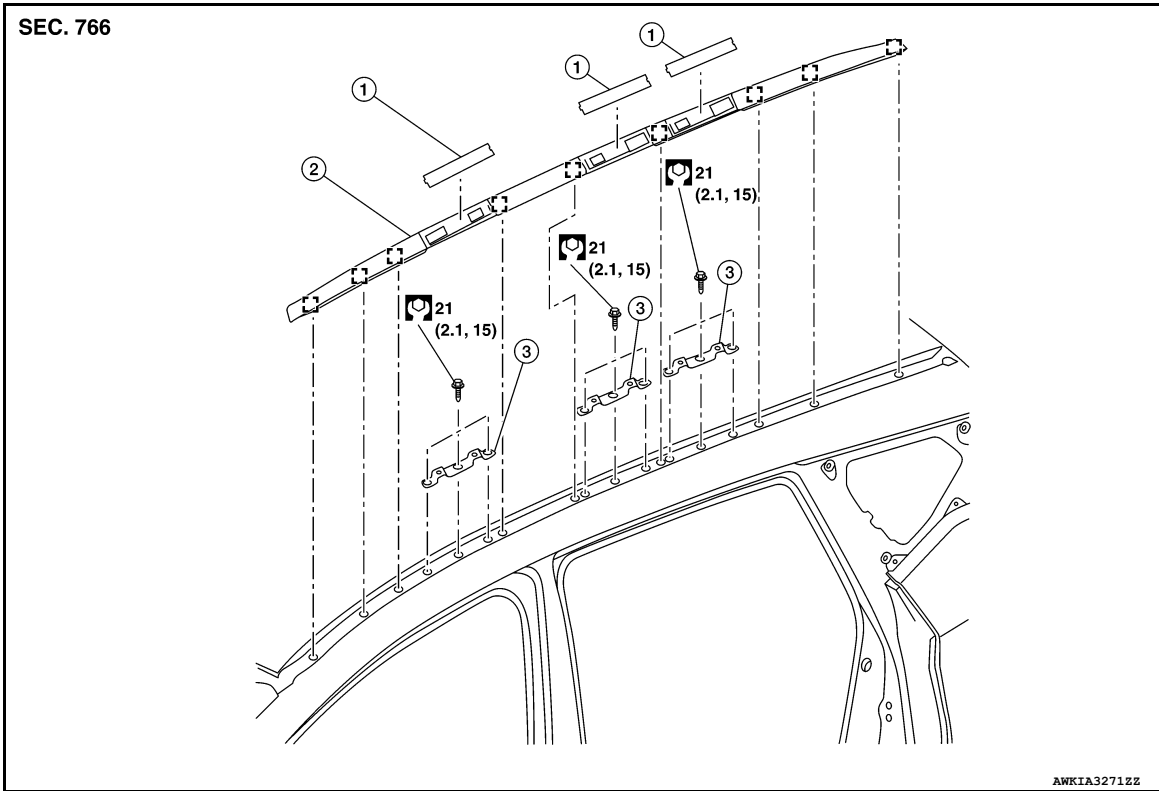

1. Roof rack bolt cover

2. Roof rack

3. Roof rack bracket

 : Metal clip

Removal and Installation

INFOID:000000011560058

REMOVAL

Beginning at the front of the vehicle, release roof rack (1) metal clips using a suitable tool (A) then remove.

 : Metal clip

CAUTION:

Apply protective tape (B) around the roof rack.

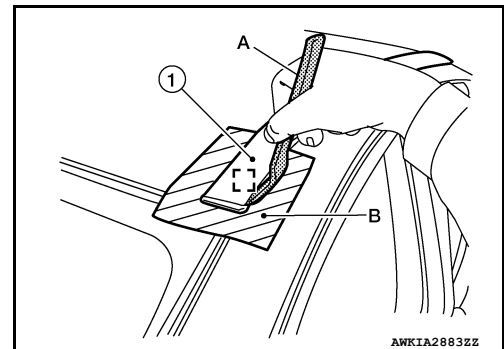

INSTALLATION

Installation is in the reverse order of removal.

A
B
C
D
E
F
G
H
I
J
L
M
N
O
P

EXT

DOOR SASH MOLDING

< REMOVAL AND INSTALLATION >

DOOR SASH MOLDING

Exploded View

INFOID:000000011560059

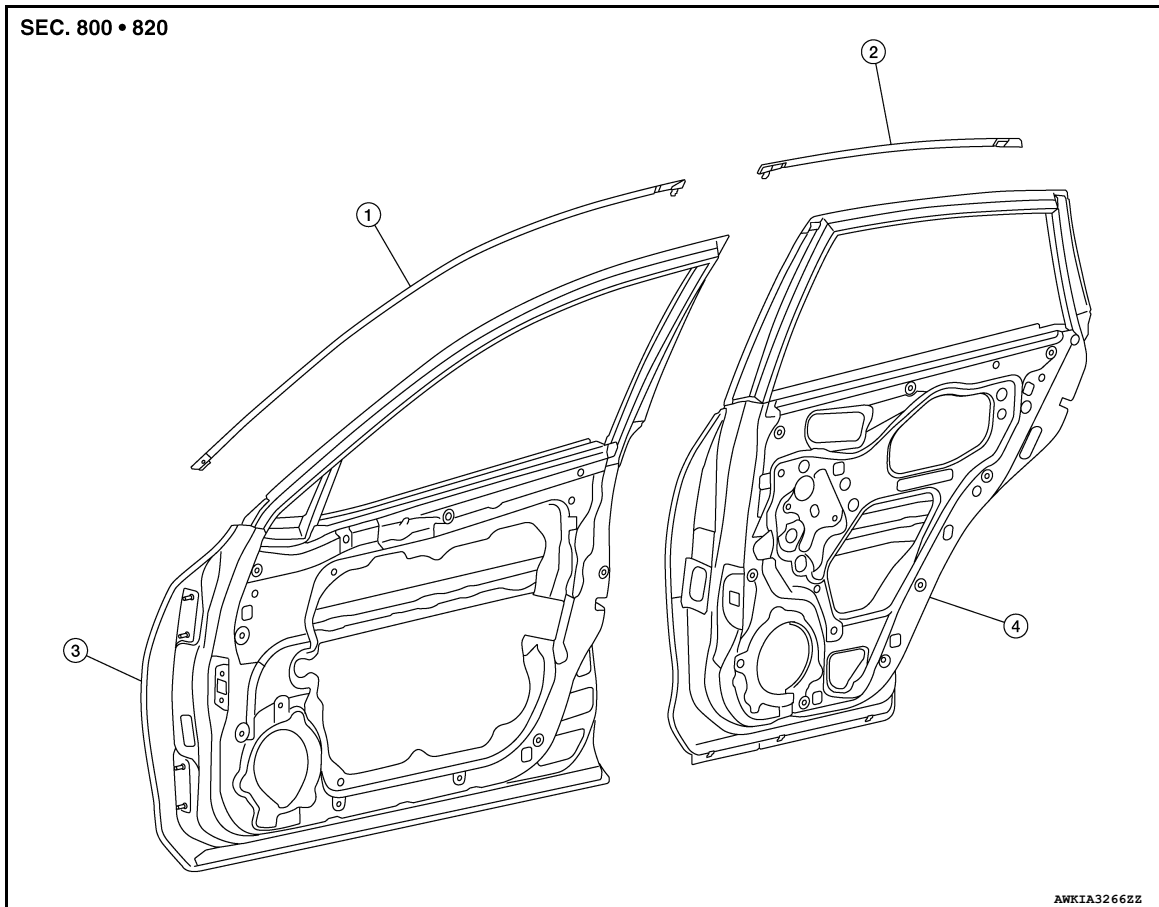

- 1. Front door sash molding
- 2. Rear door rear sash molding
- 3. Front door panel
- 4. Rear door panel

Removal and Installation

INFOID:000000011560060

FRONT DOOR

Removal

1. Remove door mirror. Refer to [MIR-21. "Removal and Installation"](#).
2. Remove front door sash molding clip (A) using a suitable tool (B).

CAUTION:

Do not reuse the clip (A).

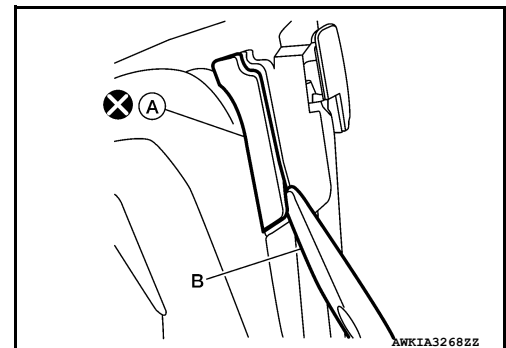

DOOR SASH MOLDING

< REMOVAL AND INSTALLATION >

- Using a suitable tool (A), release front door sash molding (1) as shown and remove.

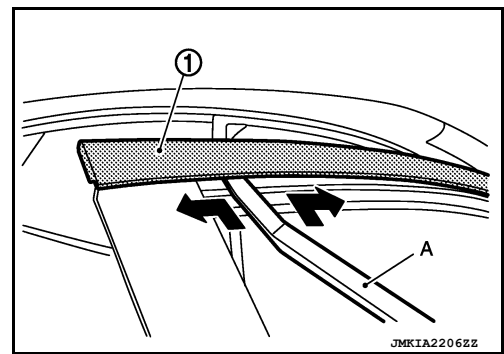

Installation

Installation is in the reverse order of removal.

REAR DOOR

Removal

- Remove rear door front sash molding clip (A) using a suitable tool (B).

CAUTION:

Do not reuse the clip (A).

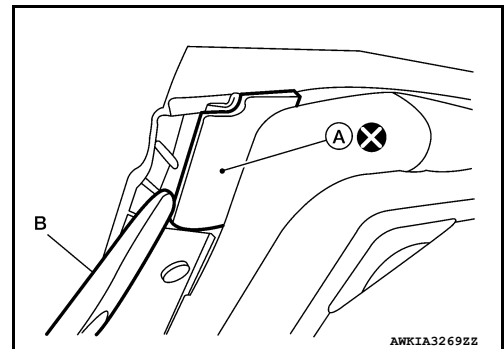

- Remove rear door rear sash molding clip (A) using a suitable tool (B).

CAUTION:

Do not reuse the clip (A).

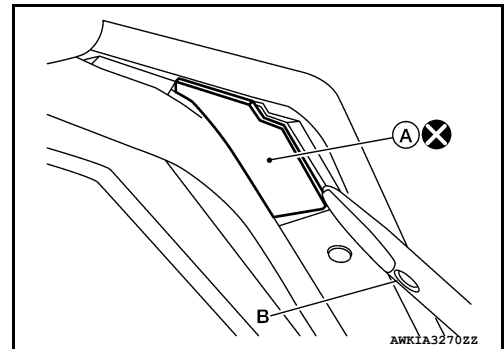

- Using a suitable tool (A), release rear door sash molding (1) as shown and remove.

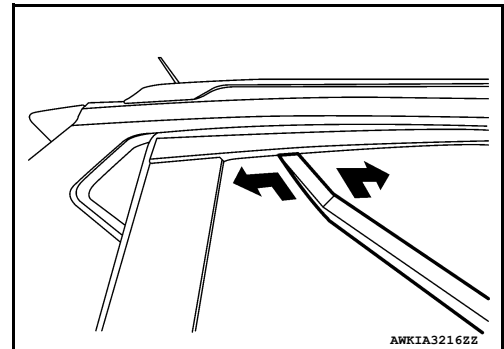

Installation

Installation is in the reverse order of removal.

A
B
C
D
E
F
G
H
I
J
L
M
N
O
P

EXT

DOOR OUTSIDE MOLDING

< REMOVAL AND INSTALLATION >

DOOR OUTSIDE MOLDING

Exploded View

INFOID:000000011560061

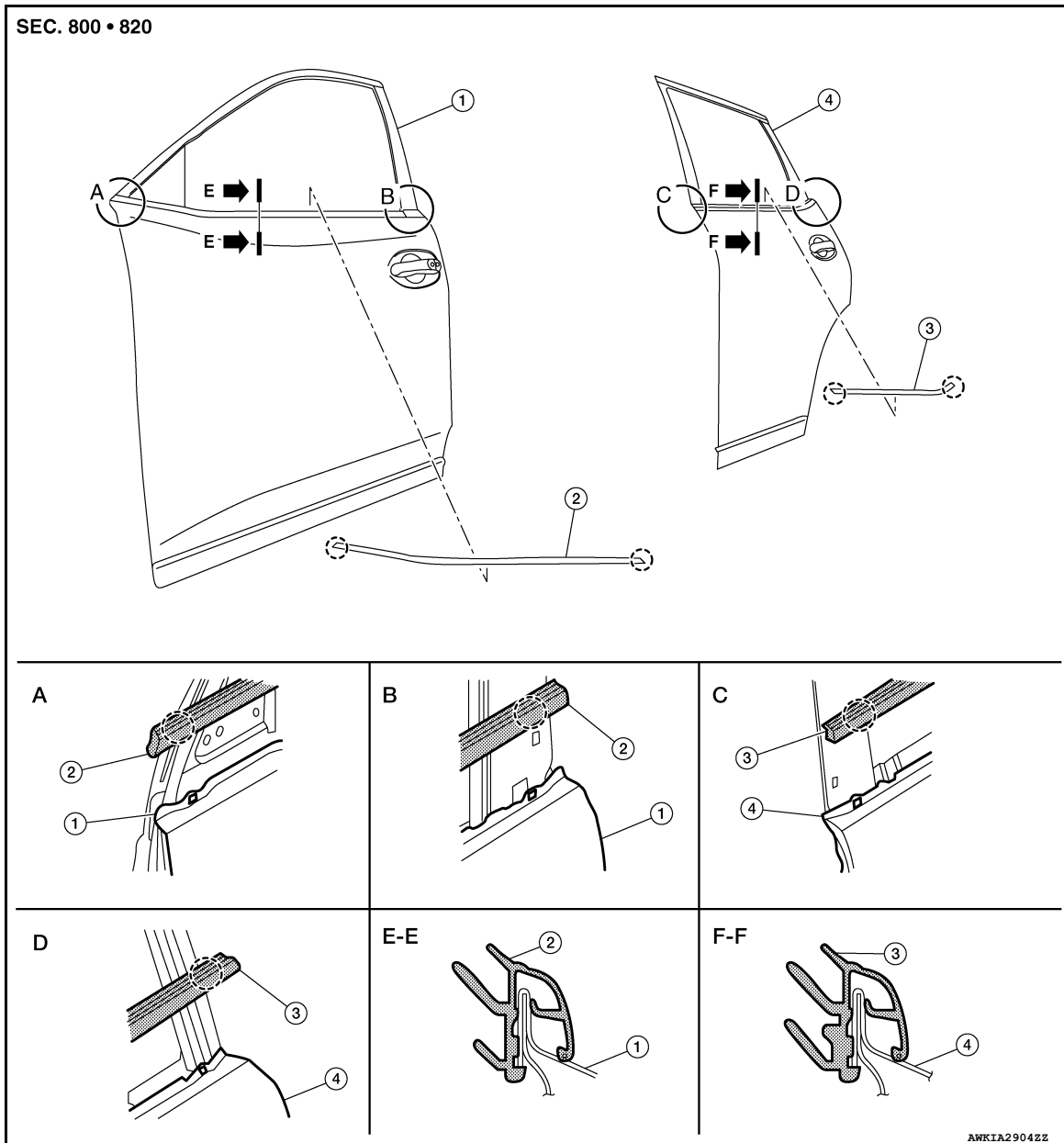

1. Front door panel

2. Front door outside molding

3. Rear door panel

4. Rear door outside molding

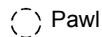

Removal and Installation

INFOID:000000011560062

FRONT DOOR OUTSIDE MOLDING

Removal

1. Lower front door glass.
2. Remove door mirror. Refer to [MIR-21, "Removal and Installation"](#).

DOOR OUTSIDE MOLDING

< REMOVAL AND INSTALLATION >

3. Release front pawl then rear pawl using a suitable tool (A) and remove front door outside molding (1).

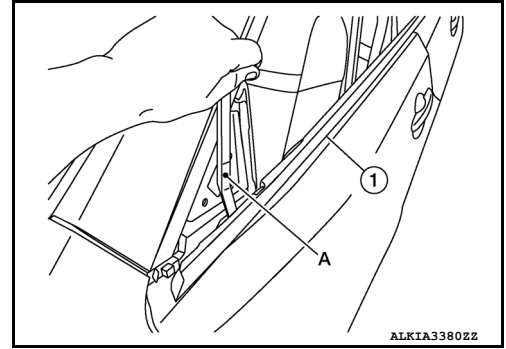

Installation

Installation is in the reverse order of removal.

REAR DOOR OUTSIDE MOLDING

Removal

1. Lower rear door glass.
2. Release front pawl then rear pawl using a suitable tool (A) and remove rear door outside molding (1).

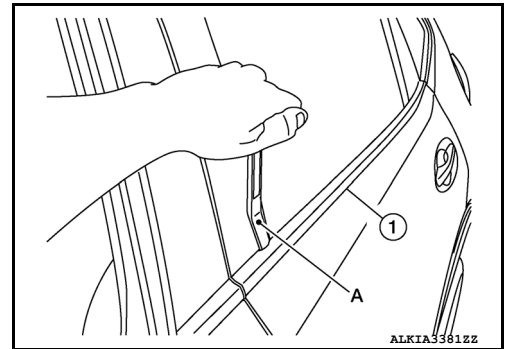

Installation

Installation is in the reverse order of removal.

A
B
C
D
E
F
G
H
I
J

EXT

L
M
N
O
P

DOOR OUTSIDE LOWER MOLDING

< REMOVAL AND INSTALLATION >

DOOR OUTSIDE LOWER MOLDING

Exploded View

INFOID:000000011560445

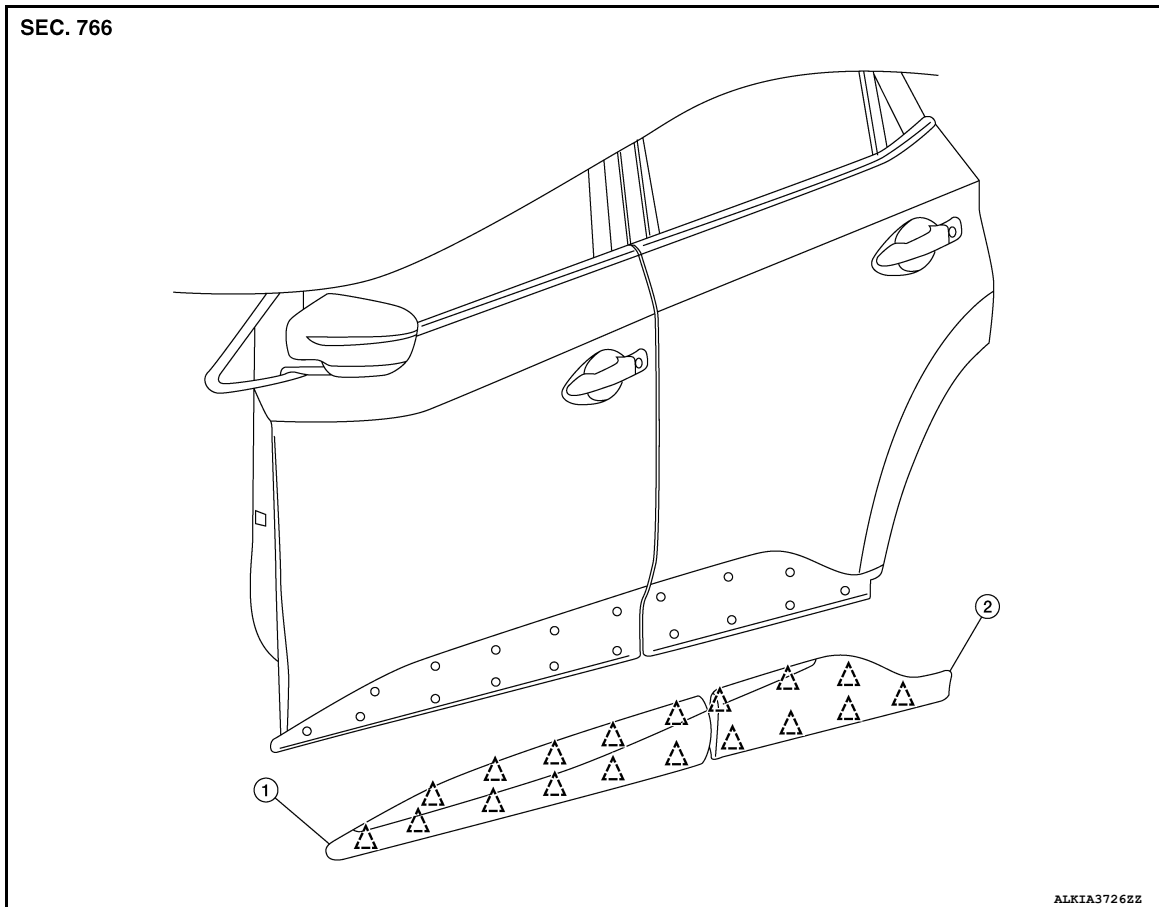

1. Front door outside lower molding 2. Rear door outside lower molding  Clip

Removal and Installation

INFOID:000000011560446

FRONT DOOR OUTSIDE LOWER MOLDING

Removal

1. Using a suitable tool (A), release clips from front door outside lower molding (1) starting at the rear and working forward.

CAUTION:

- Release the clips slowly and carefully.
- Do not pull the front door outside lower molding.

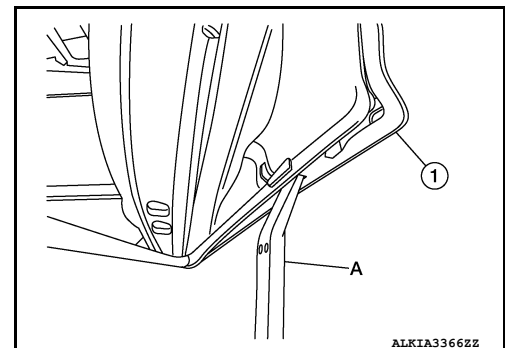

2. Remove the front door outside lower molding.

Installation

Installation is in the reverse order of removal.

CAUTION:

- Do not reuse double-sided tape; always replace with new tape.

DOOR OUTSIDE LOWER MOLDING

< REMOVAL AND INSTALLATION >

- When installing, visually check the front door outside lower molding and clips; replace with new clips if they have been damaged.
- When installing front door outside lower molding, make sure clips are attached to the molding. Make sure all old clips have been removed from door.

REAR DOOR OUTSIDE LOWER MOLDING

Removal

1. Using a suitable tool (A), release clips from rear door outside lower molding (1) starting at the rear and working forward.

CAUTION:

- Release the clips slowly and carefully.
- Do not pull the front door outside lower molding.

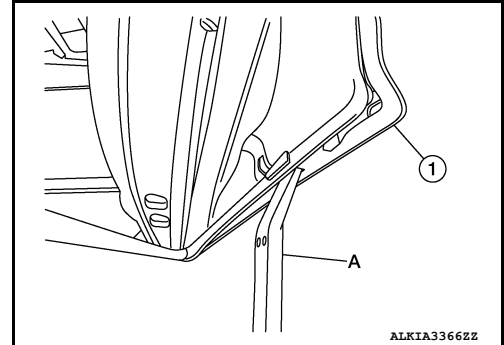

2. Remove the rear door outside lower molding.

Installation

Installation is in the reverse order of removal.

CAUTION:

- Do not reuse double-sided tape; always replace with new tape.
- When installing, visually check the rear door outside lower molding and clips; replace with new clips if they have been damaged.
- When installing rear door outside lower molding, make sure clips are attached to the molding. Make sure all old clips have been removed from door.

A
B
C
D
E
F
G
H
I
J
L
M
N
O
P

EXT

QUARTER GLASS MOLDING

< REMOVAL AND INSTALLATION >

QUARTER GLASS MOLDING

Exploded View

INFOID:000000011560455

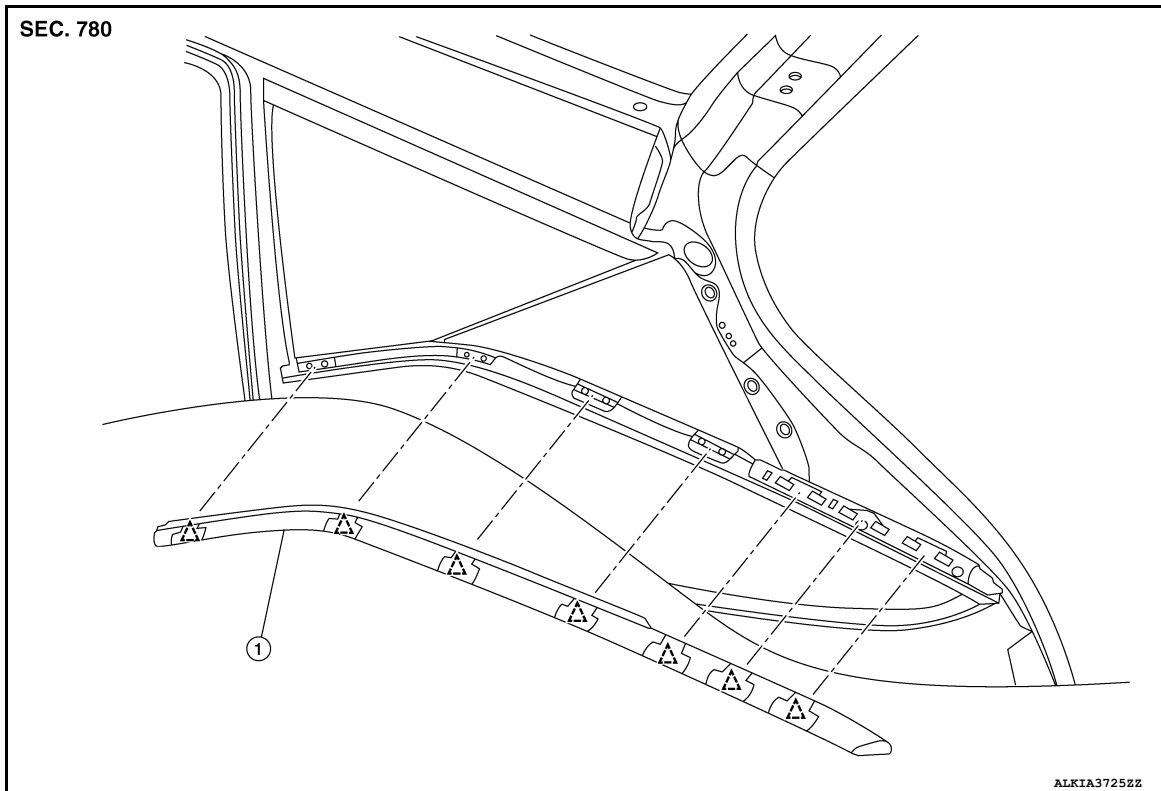

1. Quarter glass molding

 : Clip

Removal and Installation

INFOID:000000011560456

REMOVAL

Release quarter glass molding clips with a suitable tool then remove.

CAUTION:

Disengage the clips slowly and carefully.

INSTALLATION

Installation is in the reverse order of removal.

CAUTION:

- When installing, visually check the quarter glass molding and the clips and replace them with new parts if they have been damaged.
- When installing the quarter glass molding, check that clips are securely fitted in panel holes on body, and then press them in.

REAR SPOILER

< REMOVAL AND INSTALLATION >

REAR SPOILER

Exploded View

INFOID:000000011560453

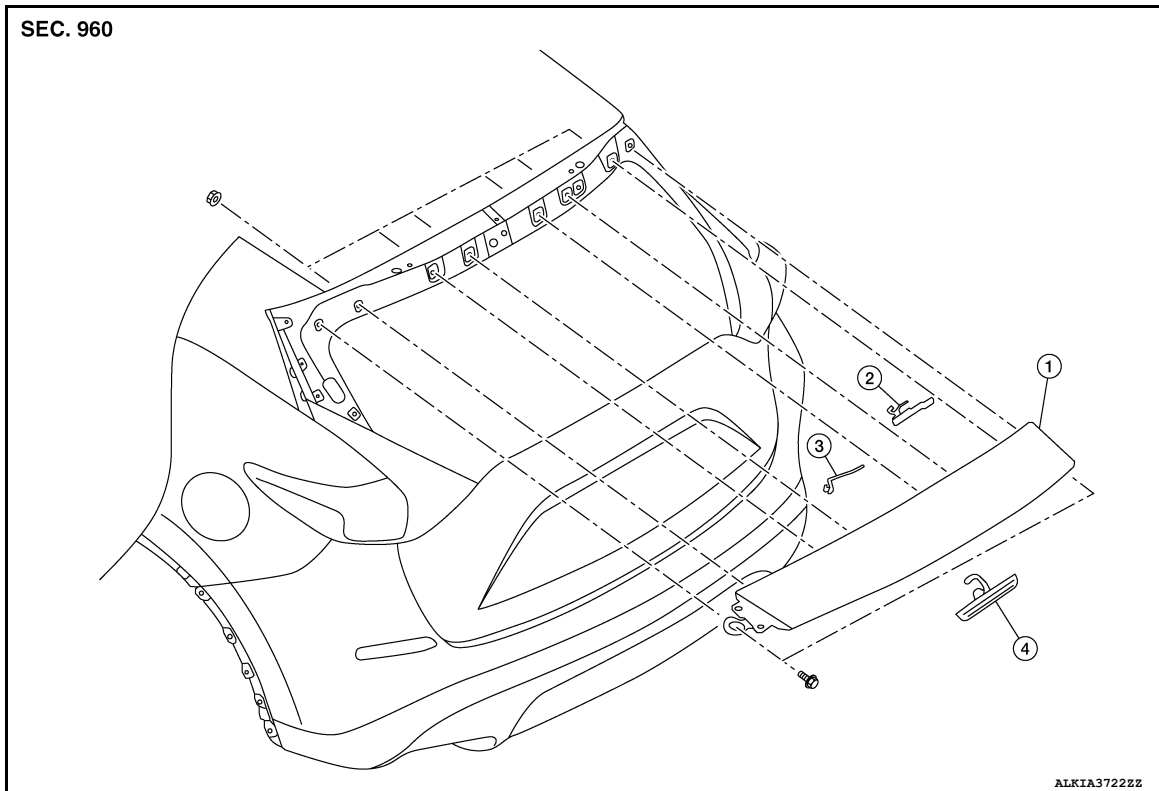

- 1. Rear spoiler
- 2. Antenna amplifier
- 3. Rear washer nozzle
- 4. High-mounted stop lamp

Removal and Installation

INFOID:000000011560447

EXT

REMOVAL

1. Remove side air spoiler. Refer to [EXT-52, "Removal and Installation"](#).
2. Remove back door upper finisher. Refer to [INT-33, "BACK DOOR UPPER FINISHER : Removal and Installation"](#).
3. Remove rear spoiler nuts and bolts and remove.

INSTALLATION

Installation is in the reverse order of removal.

A
B
C
D
E
F
G
H
I
J
L
M
N
O
P

SIDE AIR SPOILER

< REMOVAL AND INSTALLATION >

SIDE AIR SPOILER

Exploded View

INFOID:000000011560448

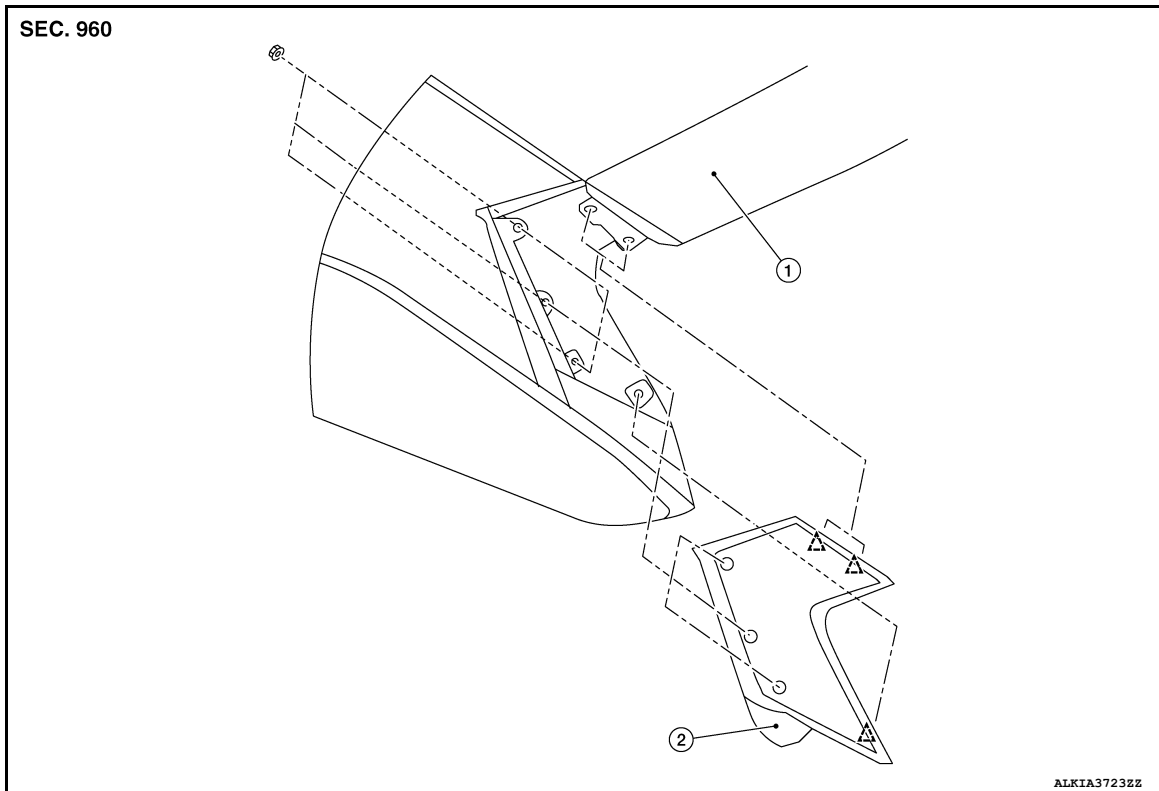

1. Rear air spoiler

2. Side air spoiler

△ : Clip

Removal and Installation

INFOID:000000011560449

REMOVAL

1. Remove luggage side upper finisher. Refer to [INT-31, "LUGGAGE SIDE UPPER FINISHER : Removal and Installation"](#).
2. Remove rear combination lamp. Refer to [EXL-136, "Removal and Installation"](#) (LED HEADLAMP) or [EXL-269, "Removal and Installation"](#) (HALOGEN TYPE).
3. Remove side air spoiler bolts.
4. Release clips using a suitable tool and remove.

INSTALLATION

Installation is in the reverse order of removal.

CAUTION:

- When installing, visually check the side air spoiler and clips and replace them with new parts if they have been damaged.
- When installing side air spoiler, check that clips and bolts are securely placed in body panel holes.

BACK DOOR OUTER FINISHER

< REMOVAL AND INSTALLATION >

BACK DOOR OUTER FINISHER

Exploded View

INFOID:000000011241646

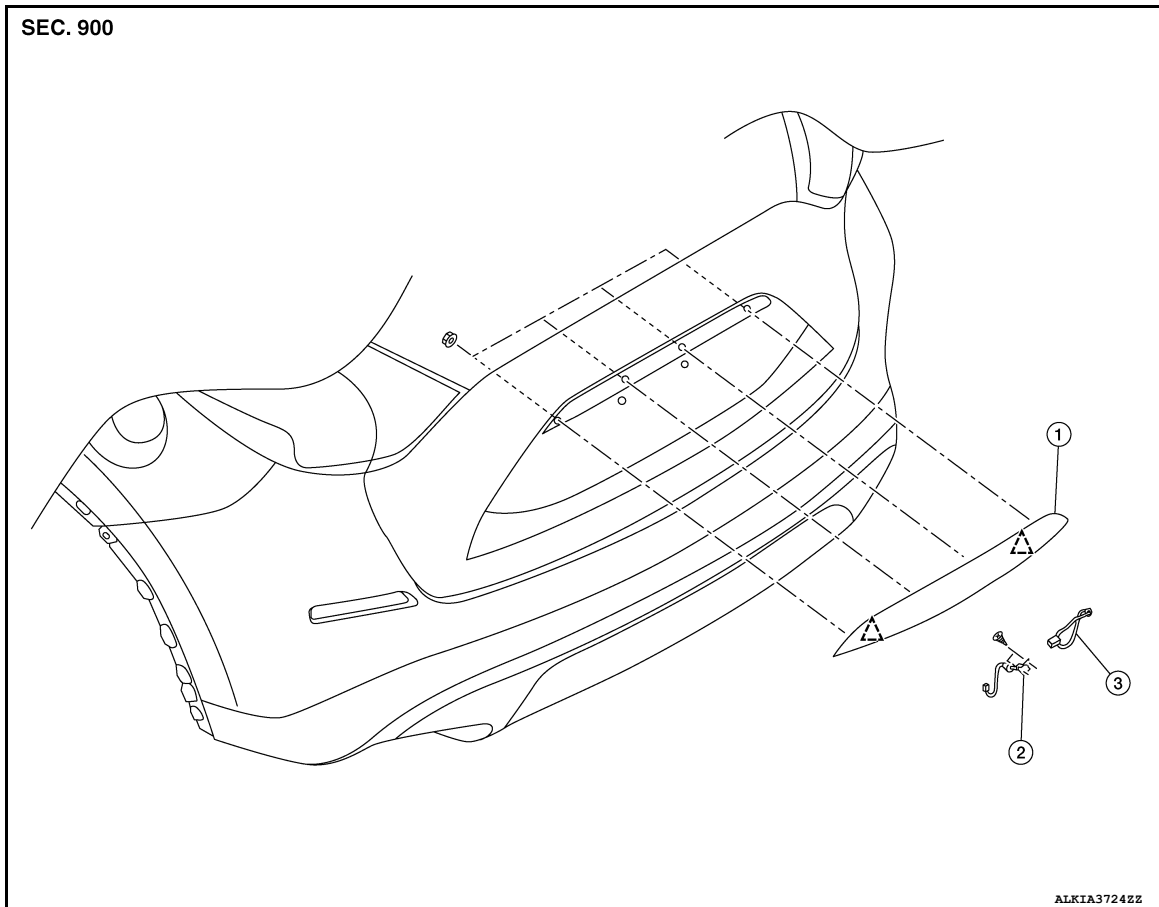

1. Back door outer finisher

2. Rear view camera

3. Back door request switch

 : Clip

EXT

Removal and Installation

INFOID:000000011241647

REMOVAL

1. Remove back door lower finisher. Refer to [INT-34, "BACK DOOR LOWER FINISHER : Removal and Installation"](#).
2. Disconnect the harness connectors from back door request switch and rear view camera.
3. Remove back door outer finisher nuts.
4. Release clips and remove the back door outer finisher.

INSTALLATION

Installation is in the reverse order of removal.

CAUTION:

When installing back door finisher, check that clips are securely placed into body panel holes.