

SECTION **RAX**
REAR AXLE

A
B
C

RAX

CONTENTS

E

PRECAUTION 2

PRECAUTIONS 2

 Precaution for Supplemental Restraint System (SRS) "AIR BAG" and "SEAT BELT PRE-TENSIONER"2

 Precautions for Drive Shaft2

PREPARATION 3

PREPARATION 3

 Special Service Tool3

 Commercial Service Tool3

SYMPTOM DIAGNOSIS 5

NOISE, VIBRATION AND HARSHNESS (NVH) TROUBLESHOOTING 5

 NVH Troubleshooting Chart5

PERIODIC MAINTENANCE 6

WHEEL HUB 6

 On-vehicle Service6

 Inspection6

REAR DRIVE SHAFT 7

 Inspection 7

REMOVAL AND INSTALLATION 8

REAR WHEEL HUB 8

 Exploded View 8

 Removal and Installation 8

REAR DRIVE SHAFT11

 Exploded View11

 Removal and Installation11

UNIT DISASSEMBLY AND ASSEMBLY ...13

REAR DRIVE SHAFT13

 Exploded View13

 Disassembly and Assembly13

SERVICE DATA AND SPECIFICATIONS (SDS)19

SERVICE DATA AND SPECIFICATIONS (SDS)19

 Wheel Bearing19

 Drive Shaft19

F
G
H
I
J
K
L
M
N
O
P

PRECAUTIONS

< PRECAUTION >

PRECAUTION

PRECAUTIONS

Precaution for Supplemental Restraint System (SRS) "AIR BAG" and "SEAT BELT PRE-TENSIONER"

INFOID:000000011220597

The Supplemental Restraint System such as "AIR BAG" and "SEAT BELT PRE-TENSIONER", used along with a front seat belt, helps to reduce the risk or severity of injury to the driver and front passenger for certain types of collision. Information necessary to service the system safely is included in the SR and SB section of this Service Manual.

WARNING:

- To avoid rendering the SRS inoperative, which could increase the risk of personal injury or death in the event of a collision which would result in air bag inflation, all maintenance must be performed by an authorized NISSAN/INFINITI dealer.
- Improper maintenance, including incorrect removal and installation of the SRS, can lead to personal injury caused by unintentional activation of the system. For removal of Spiral Cable and Air Bag Module, see the SR section.
- Do not use electrical test equipment on any circuit related to the SRS unless instructed to in this Service Manual. SRS wiring harnesses can be identified by yellow and/or orange harnesses or harness connectors.

PRECAUTIONS WHEN USING POWER TOOLS (AIR OR ELECTRIC) AND HAMMERS

WARNING:

- When working near the Airbag Diagnosis Sensor Unit or other Airbag System sensors with the Ignition ON or engine running, DO NOT use air or electric power tools or strike near the sensor(s) with a hammer. Heavy vibration could activate the sensor(s) and deploy the air bag(s), possibly causing serious injury.
- When using air or electric power tools or hammers, always switch the Ignition OFF, disconnect the battery and wait at least three minutes before performing any service.

Precautions for Drive Shaft

INFOID:000000011220598

Observe the following precautions when disassembling and assembling drive shaft:

- Joint sub-assembly does not disassemble because it is non-overhaul parts.
- Perform work in a location which is as dust-free as possible.
- Before disassembling and assembling, clean the outside of parts.
- Prevention of the entry of foreign objects must be taken into account during disassembly of the service location.
- Disassembled parts must be carefully reassembled in the correct order. If work is interrupted, a clean cover must be placed over parts.
- Paper shop cloths must be used. Fabric shop cloths must not be used because of the danger of lint adhering to parts.
- Disassembled parts (except for rubber parts) should be cleaned with kerosene which shall be removed by blowing with air or wiping with paper shop cloths.

PREPARATION

< PREPARATION >

PREPARATION

PREPARATION

Special Service Tool

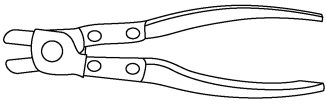
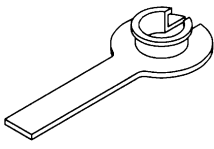

INFOID:000000011220599

The actual shape of the tools may differ from those illustrated here.

| Tool number (TechMate No.) Tool name | Description |
|--|------------------------|
| KV40107300 (J-51751) Boot band crimping tool  <small>ALDIA05862Z</small> | Installing boot band |
| KV38107900 (—) Differential side oil seal protector  <small>NT147</small> | Installing drive shaft |

Commercial Service Tool

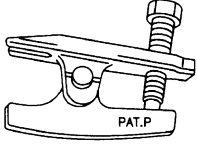
INFOID:000000011220600

| Tool name | Description |
|---|----------------------------------|
| Ball joint remover  <small>PAT.P</small> <small>NT146</small> | Removing wheel stud |
| Power tool  <small>PIIB1407E</small> | Loosening nuts, screws and bolts |

PREPARATION

< PREPARATION >

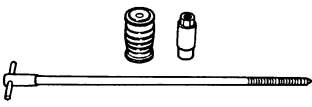
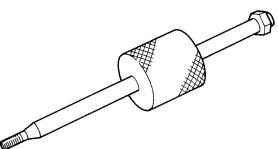
| | |
|--|--|
| <p>Drive shaft puller</p>  <p>JPDIG0152ZZ</p> | <p>Removing drive shaft joint sub-assembly</p> |
| <p>Sliding hammer</p>  <p>ZZA0023D</p> | <p>Removing drive shaft</p> |

NOISE, VIBRATION AND HARSHNESS (NVH) TROUBLESHOOTING

< SYMPTOM DIAGNOSIS >

SYMPTOM DIAGNOSIS

NOISE, VIBRATION AND HARSHNESS (NVH) TROUBLESHOOTING

NVH Troubleshooting Chart

INFOID:0000000011220601

Use chart below to find the cause of the symptom. If necessary, repair or replace these parts.

| Reference | | — | RAX-13 | — | RAX-8 | — | DLN-87 | DLN-102 | RSU-4 | RAX-6 | WT-63 | WT-63 | RAX-7 | BR-6 | |
|------------------------------------|-------------|-------------------------------|--------------------------|-----------|----------------------------------|--------------------|------------------------|-------------------------|-----------------------|-----------------------|-----------------------|-----------------------|-----------------------|----------------------|---|
| Possible cause and SUSPECTED PARTS | | Excessive joint angle | Joint sliding resistance | Imbalance | Improper installation, looseness | Parts interference | PROPELLER SHAFT (AWD) | DIFFERENTIAL (AWD) | REAR SUSPENSION | REAR AXLE | TIRE | WHEEL | DRIVE SHAFT (AWD) | BRAKE | |
| Symptom | DRIVE SHAFT | Noise | x | x | | | x | x | x | x | x | x | | x | |
| | | Shake | x | | x | | | x | | x | x | x | | x | |
| | REAR AXLE | Noise | | | | x | x | x | x | | x | x | x | x | x |
| | | Shake | | | | x | x | x | | x | | x | x | x | x |
| | | Vibration | | | | x | x | x | | x | | x | | x | |
| | | Shimmy | | | | x | x | | | x | | x | x | | x |
| | | Shudder | | | | x | | | | x | | x | x | | x |
| | | Poor quality ride or handling | | | | x | x | | | x | | x | x | | |

x: Applicable

A
B
C
RAX
E
F
G
H
I
J
K
L
M
N
O
P

WHEEL HUB

< PERIODIC MAINTENANCE >

PERIODIC MAINTENANCE

WHEEL HUB

On-vehicle Service

INFOID:0000000011220602

Check axle and suspension parts for excessive play, wear or damage.

- Move the wheel as shown to check for excessive play.

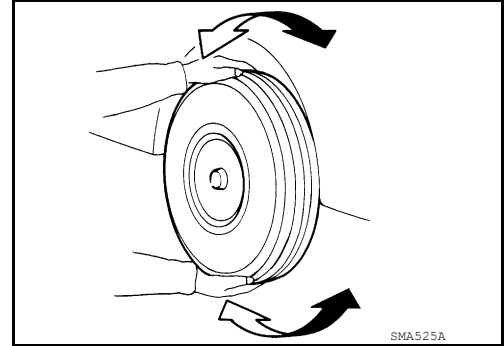

Inspection

INFOID:0000000011220603

Rear Wheel Bearing

- Check wheel hub bearing axial end play.

Axial end play : Refer to [RAX-19, "Wheel Bearing"](#).

- Check that wheel hub bearings operate smoothly. Rotate the wheel hub and check for irregular conditions or unusual noise.
- Replace wheel hub if there is excessive axial end play or if wheel bearing does not turn smoothly. Refer to [RAX-8, "Removal and Installation"](#).

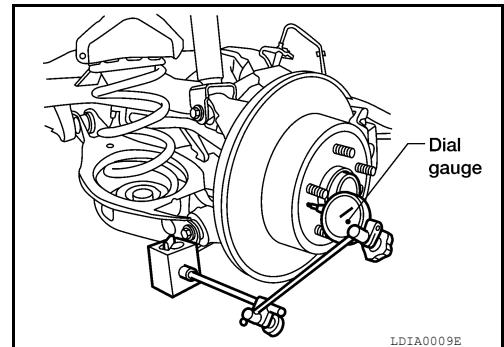

REAR DRIVE SHAFT

< PERIODIC MAINTENANCE >

REAR DRIVE SHAFT

Inspection

INFOID:000000011220604

Check the following items, and replace the parts as necessary.

- Check drive shaft mounting points and drive shaft joint for looseness and other damage.

CAUTION:

Replace entire drive shaft when noise or vibration occurs from drive shaft.

- Check boot for cracks and other damage.

A

B

C

RAX

E

F

G

H

I

J

K

L

M

N

O

P

REAR WHEEL HUB

< REMOVAL AND INSTALLATION >

REMOVAL AND INSTALLATION

REAR WHEEL HUB

Exploded View

INFOID:000000011220605

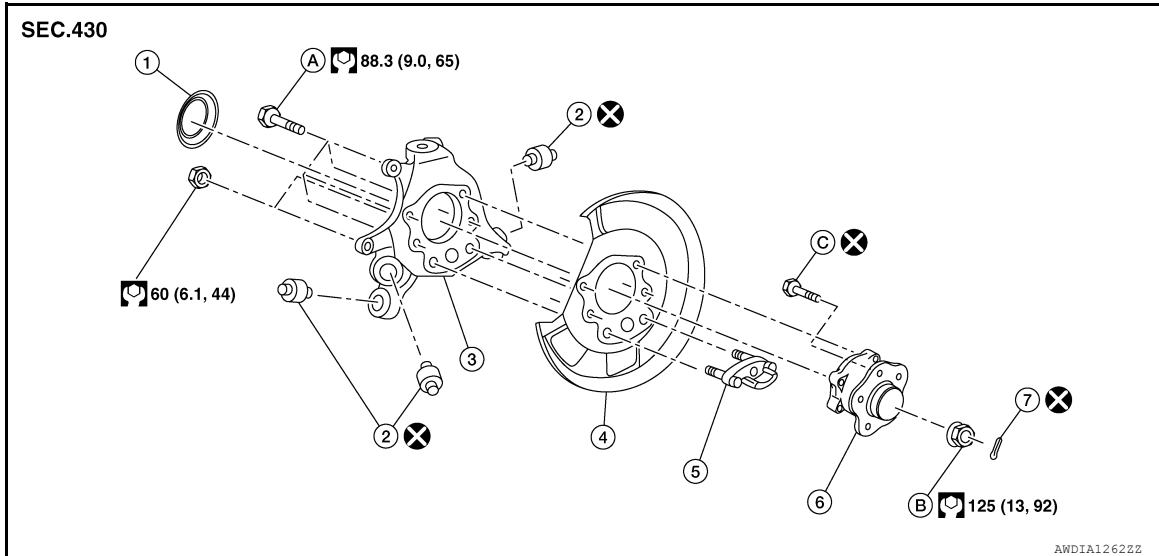

- | | | |
|---------------------|------------------------------------|-----------------------------|
| 1. Hub cap | 2. Bushings | 3. Rear knuckle |
| 4. Back plate | 5. Anchor block | 6. Wheel hub and bearing |
| 7. Cotter pin (AWD) | A. Rear wheel hub and bearing bolt | B. Wheel hub lock nut (AWD) |
| C. Wheel stud | | |

Removal and Installation

INFOID:000000011220606

REMOVAL

1. Remove disc brake rotor. Refer to [BR-45, "DISC BRAKE ROTOR : Removal and Installation"](#).
2. Remove bolt (1) and separate rear wheel sensor from knuckle. Refer to [BRC-139, "REAR WHEEL SENSOR : Removal and Installation"](#).

CAUTION:

- Pull out rear wheel sensor being careful to turn it as little as possible. Do not pull on wheel sensor harness.
- Failure to remove rear wheel sensor from rear knuckle may result in damage to rear wheel sensor.

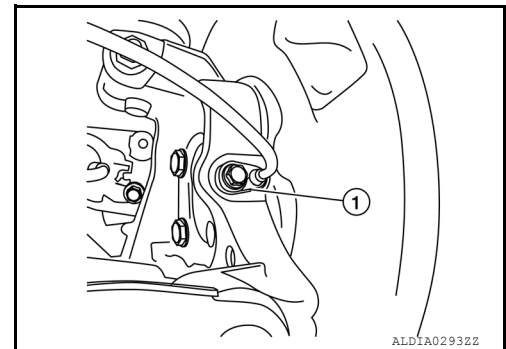

3. For AWD vehicles, remove cotter pin.
4. For AWD vehicles, loosen, but do not remove, the wheel hub lock nut from drive shaft using power tool.

REAR WHEEL HUB

< REMOVAL AND INSTALLATION >

5. For AWD vehicles, using a piece of wood and a suitable tool, tap on wheel hub lock nut to disengage drive shaft from wheel hub and bearing.

CAUTION:

- Do not place drive shaft joint at an extreme angle. Be careful not to over-extend slide joint.
- Do not allow drive shaft to hang without support.

NOTE:

Use a suitable puller if the drive shaft cannot be separated from wheel hub and bearing.

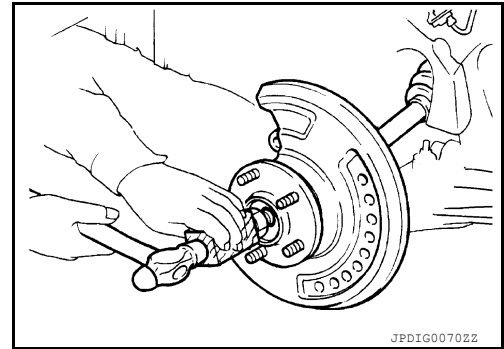

6. For AWD vehicles, remove wheel hub lock nut.
7. Remove wheel hub and bearing bolts (A).

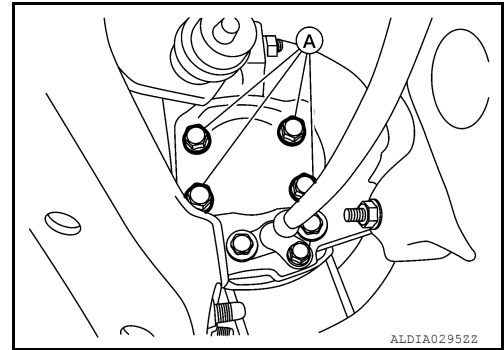

8. Remove wheel hub and bearing.
9. Remove hub cap.
10. If necessary, remove wheel studs (1) from wheel hub and bearing using a suitable tool (A).

CAUTION:

- Remove wheel studs only when necessary.
- Do not hammer wheel studs or damage to wheel hub and bearing may occur.
- Pull out wheel studs in a direction perpendicular to wheel hub and bearing.

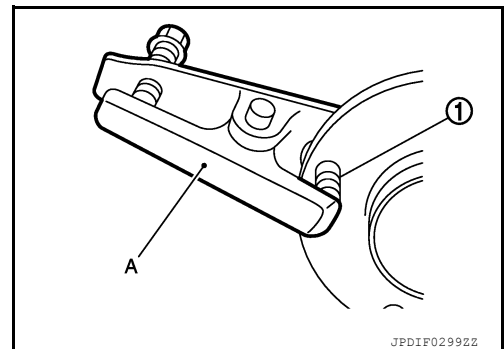

INSPECTION AFTER REMOVAL

Wheel Hub and Bearing

Check wheel hub and bearing for wear, cracks, and damage. Replace wheel hub and bearing if necessary.

Rear Knuckle

Check rear knuckle for wear, cracks, and damage. Replace rear knuckle if necessary.

INSTALLATION

Installation is in reverse order of removal.

CAUTION:

Do not use a power tool to tighten wheel hub lock nut.

A
B
C
RAX
E
F
G
H
I
J
K
L
M
N
O
P

REAR WHEEL HUB

< REMOVAL AND INSTALLATION >

- Place a washer (A) as shown to install wheel studs (1) by using tightening force of nut (B).

CAUTION:

- Check that there is no clearance between wheel stud and wheel hub and bearing.
- Do not reuse wheel stud.

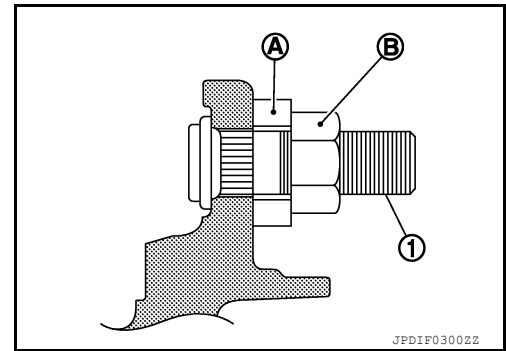

- Clean mating surface of wheel hub lock nut and wheel hub and bearing.
- Clean mating surface of drive shaft and wheel hub and bearing.
- Make sure wheel hub and bearing operate smoothly.
- Install rear wheel sensor to rear knuckle. Refer to [BRC-138. "REAR WHEEL SENSOR : Exploded View"](#).

CAUTION:

- Before installing, make sure there is no foreign material, such as iron fragments, adhered to pick-up part of rear wheel sensor.
- When installing, make sure there is no foreign material, such as iron fragments, on and in the hole in rear knuckle for rear wheel sensor. Make sure no foreign material has been caught in sensor rotor. Remove any foreign material and clean mount.
- When installing cotter pin, securely bend cotter pin to prevent rattles.

CAUTION:

Do not reuse cotter pin.

REAR DRIVE SHAFT

< REMOVAL AND INSTALLATION >

REAR DRIVE SHAFT

Exploded View

INFOID:0000000011220607

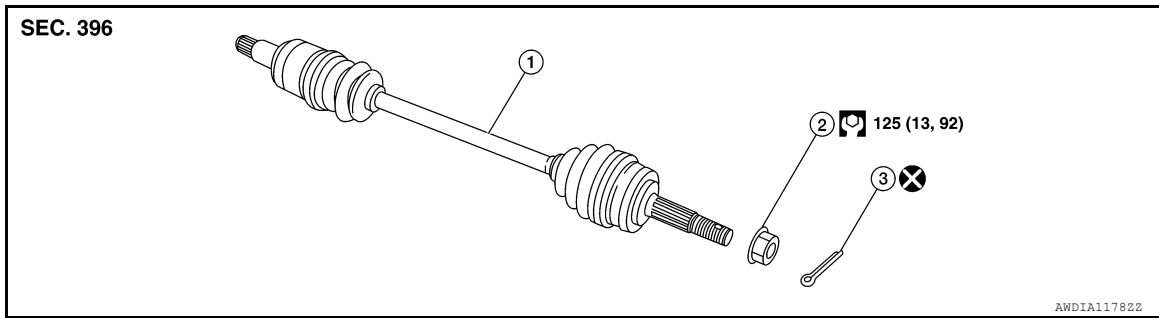

1. Drive shaft

2. Wheel hub lock nut

3. Cotter pin

Removal and Installation

INFOID:0000000011220608

REMOVAL

1. Remove rear wheel hub. Refer to [RAX-8, "Removal and Installation"](#).
2. Remove rear drive shaft from final drive.
3. Remove side oil seal. Refer to [TM-209, "Removal and Installation"](#).

INSPECTION AFTER REMOVAL

- Move joint up/down, left/right and in axial direction. Check for any rough movement or significant looseness.
- Check boots for cracks, grease leakage or other damage.
- If damaged, disassemble drive shaft to verify damage and repair or replace as necessary.

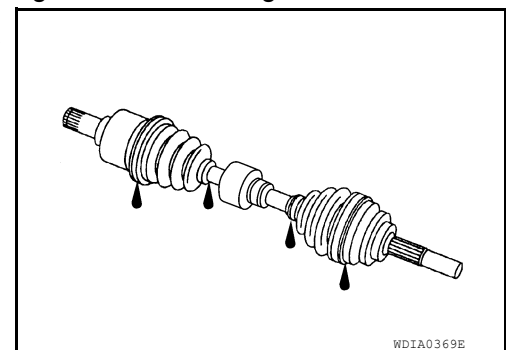

INSTALLATION

Installation is in reverse order of removal.

CAUTION:

- **Do not reuse side oil seal.**
- **Do not use a power tool to tighten wheel hub lock nut.**
- Install side oil seal. Refer to [TM-209, "Removal and Installation"](#).
- In order to prevent damage to side oil seal, place Tool (A) onto oil seal as shown before inserting drive shaft.

Tool number : KV38107900 (—)

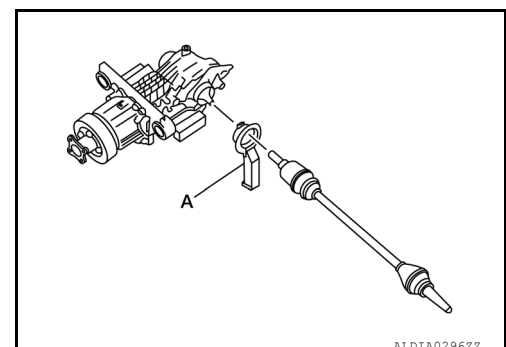

- Clean mating surface of wheel hub lock nut and wheel hub and bearing.
- Clean mating surface of drive shaft and wheel hub and bearing.

REAR DRIVE SHAFT

< REMOVAL AND INSTALLATION >

- Make sure wheel hub and bearing operate smoothly.
- Install rear wheel sensor to rear knuckle. Refer to [BRC-138, "REAR WHEEL SENSOR : Exploded View"](#).
CAUTION:
 - Before installing, make sure there is no foreign material, such as iron fragments, adhered to pick-up part of rear wheel sensor.
 - When installing, make sure there is no foreign material, such as iron fragments, on and in the hole in rear knuckle for rear wheel sensor. Make sure no foreign material has been caught in sensor rotor. Remove any foreign material and clean mount.
- When installing cotter pin, securely bend cotter pin to prevent rattles.
CAUTION:
 - Do not reuse cotter pin.
- Check the rear differential gear oil level. Refer to [DLN-103, "Inspection"](#).

REAR DRIVE SHAFT

< UNIT DISASSEMBLY AND ASSEMBLY >

UNIT DISASSEMBLY AND ASSEMBLY

REAR DRIVE SHAFT

Exploded View

INFOID:000000011541458

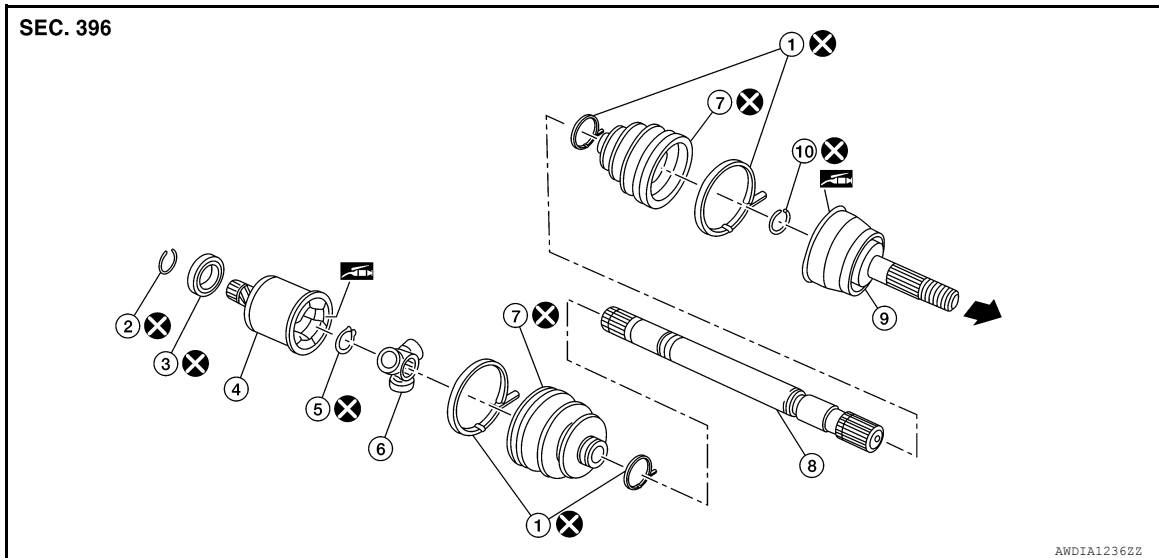

- | | | |
|-------------------|------------------|-----------------------|
| 1. Boot band | 2. Circular clip | 3. Dust shield |
| 4. Housing | 5. Snap ring | 6. Spider assembly |
| 7. Boot | 8. Shaft | 9. Joint sub-assembly |
| 10. Circular clip | ← Wheel side | |

Disassembly and Assembly

INFOID:000000011220609

DISASSEMBLY

Wheel Side

- Secure drive shaft in a vise.
CAUTION:
When securing drive shaft in a vise, always use aluminum or copper plates between vise and drive shaft.

- Remove and discard boot bands and slide boot back.
- Install suitable tool (A) 30 mm (1.18 in) or more into the threaded part of joint sub-assembly, and pull joint sub-assembly from shaft with suitable tool (B).

CAUTION:

- Align suitable tool and drive shaft then remove joint sub-assembly by pulling directly.
- If joint sub-assembly cannot be removed after five or more unsuccessful attempts, replace entire drive shaft.

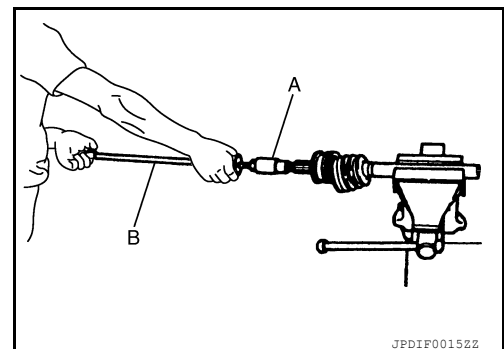

- Remove and discard circular clip from shaft.
- Remove boot from shaft.
- While rotating ball cage, clean old grease off joint sub-assembly.

Final Drive Side

- Secure drive shaft in a vise.

A
B
C
RAX
E
F
G
H
I
J
K
L
M
N
O
P

REAR DRIVE SHAFT

< UNIT DISASSEMBLY AND ASSEMBLY >

CAUTION:

When securing drive shaft in a vise, always use copper or aluminum plates between vise and shaft.

2. Remove and discard boot bands and slide boot back.
3. Put matching marks on housing and shaft before separating housing from shaft.

CAUTION:

Use paint or an equivalent for matching marks. Do not scratch surface.

4. Put matching marks (A) on spider assembly and shaft.

CAUTION:

Use paint or an equivalent for matching marks. Do not scratch surface.

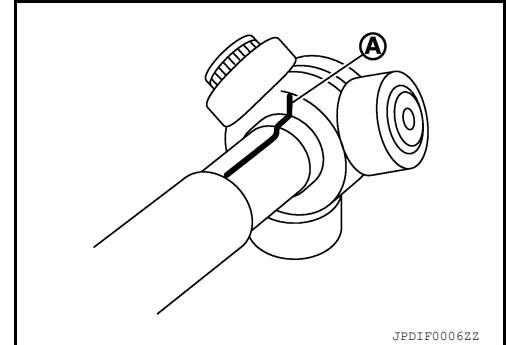

5. Remove and discard snap ring (1) using a suitable tool.
6. Remove spider assembly from shaft.
7. Remove boot from shaft.
8. Remove circular clip from housing.
9. Remove dust shield from housing.
10. Clean old grease off housing and shaft.

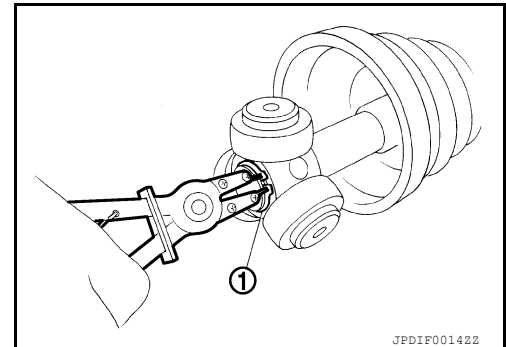

INSPECTION AFTER DISASSEMBLY

Shaft

- Replace entire drive shaft if there is any bending, cracking, or other damage.

Joint Sub-assembly

- Make sure there is no rough rotation or unusual axial looseness.
- Make sure there is no foreign material inside joint sub-assembly.
- Check joint sub-assembly for compression scars, cracks or fractures.
- If there are any irregular conditions of joint sub-assembly components, replace entire drive shaft.

Housing and Spider Assembly

- If roller surface of spider assembly has scratches or wear, replace entire drive shaft.

ASSEMBLY

Wheel Side

1. Insert Genuine NISSAN Grease into joint sub-assembly (1) until grease begins to ooze from ball groove and serration hole.

CAUTION:

After inserting grease, use a paper shop cloth to wipe off old grease that has oozed out.

NOTE:

Always check with the Parts Department for the latest parts information.

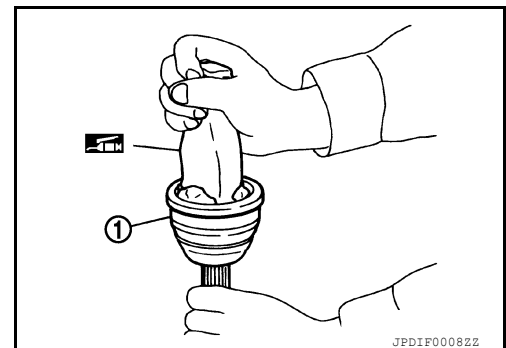

REAR DRIVE SHAFT

< UNIT DISASSEMBLY AND ASSEMBLY >

2. Install new boot and new small boot band to shaft.

CAUTION:

- Cover drive shaft serration with protective tape (A) to prevent damage to boot during installation.
- Do not reuse boot or boot bands.

3. Remove protective tape wrapped around the serrated part on shaft.

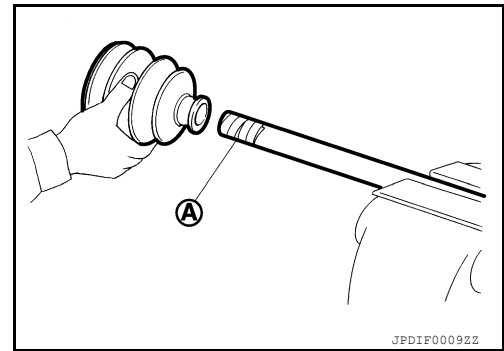

4. Attach new circular clip to shaft. Circular clip must fit securely into shaft groove. Attach nut to joint sub-assembly. Use a suitable tool to press-fit.

CAUTION:

Do not reuse circular clip.

5. Install joint sub-assembly to shaft using suitable tool.

CAUTION:

Confirm that joint sub-assembly is correctly engaged while rotating drive shaft.

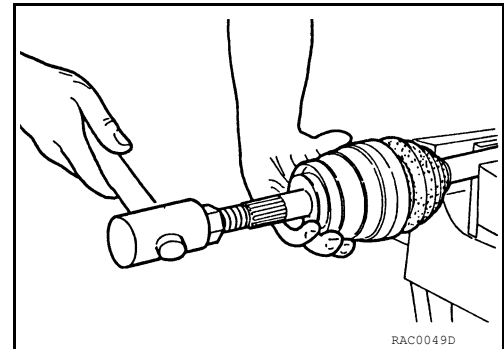

6. Insert remaining balance of the specified amount of Genuine NISSAN Grease listed below into housing from large diameter side of boot.

Grease quantity : Refer to [RAX-19, "Drive Shaft"](#).

NOTE:

Always check with the Parts Department for the latest parts information.

7. Install boot securely into grooves (indicated by "*" marks) as shown.

CAUTION:

If there is grease on the boot mounting surfaces (indicated by "*" marks) on shaft or joint sub-assembly, boot may come off. Remove all grease from boot mounting surfaces.

- To prevent deformation of boot, adjust boot installation length (L) to specified value indicated below. Insert a suitable tool into large end of boot. Bleed air from boot to prevent boot deformation.

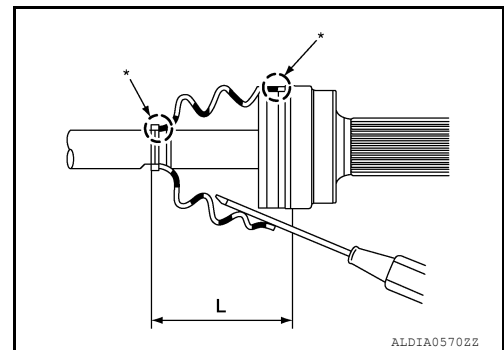

Boot installation length (L) : Refer to [RAX-19, "Drive Shaft"](#).

CAUTION:

- Boot may be damaged if installation length exceeds or is less than standard value.
- Be careful that suitable tool does not contact inside surface of boot.

8. Install new boot bands securely.

CAUTION:

Do not reuse boot band.

REAR DRIVE SHAFT

< UNIT DISASSEMBLY AND ASSEMBLY >

- a. Put boot band in groove on drive shaft boot. Then fit pawls (←) into holes for temporary installation.

NOTE:

For large diameter side, fit projection (A) and guide slit (B) at first.

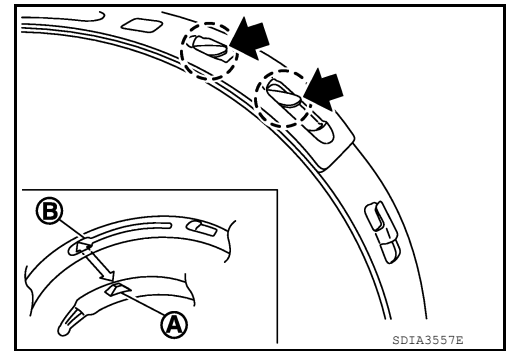

- b. Pinch projection on band with suitable pliers to tighten band.
c. Insert tip of band below end of pawl.

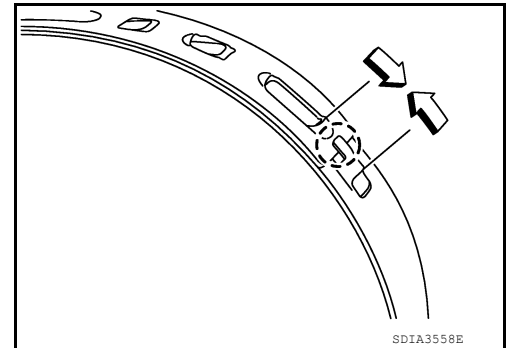

9. After installing joint sub-assembly and shaft, make sure that they are in the correct position when rotating boot. If boot position is not correct, remove old boot bands then reposition boot and secure with new boot bands.

CAUTION:

Do not reuse boot bands.

Final Drive Side

1. Install new boot and new small boot band to shaft.
CAUTION:
- Cover drive shaft serration with protective tape (A) to prevent damage to boot during installation.
 - Do not reuse boot or boot bands.
2. Remove protective tape wrapped around serrated part of shaft.

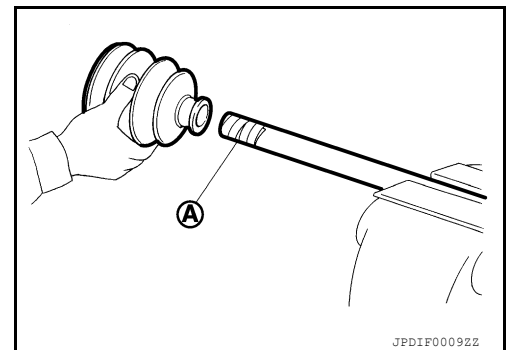

3. Align matching marks (A) on spider assembly (1) with matching mark on shaft (2). Install spider assembly to shaft with chamfer (B) facing shaft.

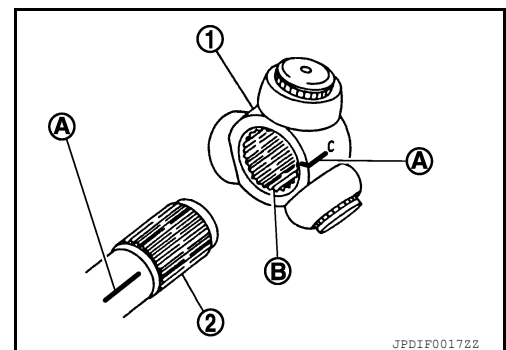

REAR DRIVE SHAFT

< UNIT DISASSEMBLY AND ASSEMBLY >

4. Install new snap ring (1) onto shaft using suitable tool.

CAUTION:

Do not reuse snap ring.

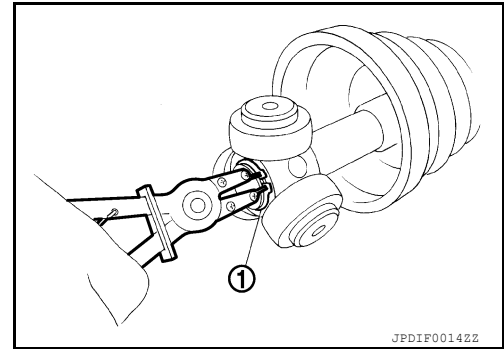

5. Pack housing with the specified amount of new Genuine NISSAN Grease.

Grease amount : Refer to [RAX-19, "Drive Shaft"](#).

NOTE:

Always check with the Parts Department for the latest parts information.

6. Align matching marks made during disassembly and install housing onto spider assembly.
7. After installation, pull shaft to check engagement between slide joint assembly and circular clip.
8. Install boot securely into grooves (indicated by "*" marks) as shown.

CAUTION:

If there is grease on boot mounting surfaces (indicated by "*" marks) on shaft or housing, boot may come off. Clean all grease from the boot mounting surfaces.

9. Make sure boot installation length (L) is length specified below. Insert a suitable tool into large end of boot. Bleed air from boot to prevent boot deformation.

Boot installation length (L) : Refer to [RAX-19, "Drive Shaft"](#).

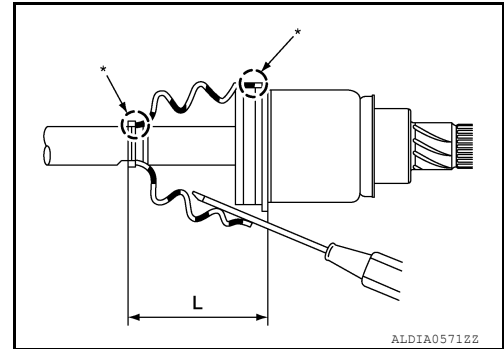

CAUTION:

- Boot may break if boot installation length exceeds or is less than standard value.
- Be careful that suitable tool does not contact inside surface of the boot.

10. Install new boot bands securely.

CAUTION:

Do not reuse boot band.

- a. Put boot band in groove on drive shaft boot. Then fit pawls (←) into holes for temporary installation.

NOTE:

For the large diameter side, fit projection (A) and guide slit (B) at first.

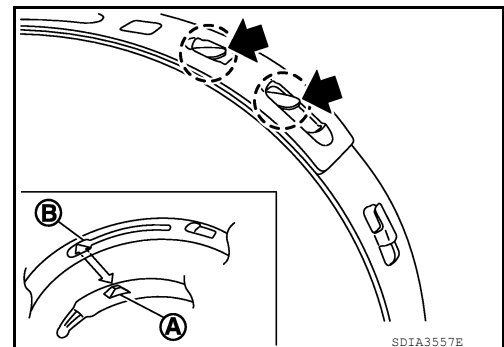

REAR DRIVE SHAFT

< UNIT DISASSEMBLY AND ASSEMBLY >

- b. Pinch projection on band with suitable pliers to tighten band.
- c. Insert tip of band below end of pawl.

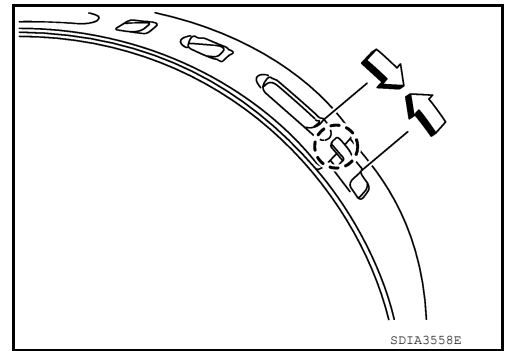

11. After installing housing and shaft, rotate boot to validate position is correct. If boot position is incorrect, remove boot bands and reposition boot then secure with new boot bands.

CAUTION:

Do not reuse boot band.

12. Install a new dust shield.

CAUTION:

Do not reuse dust shield.

13. Install a new circular clip.

CAUTION:

Do not reuse circular clip.

SERVICE DATA AND SPECIFICATIONS (SDS)

< SERVICE DATA AND SPECIFICATIONS (SDS)

SERVICE DATA AND SPECIFICATIONS (SDS)

SERVICE DATA AND SPECIFICATIONS (SDS)

Wheel Bearing

INFOID:0000000011220610

| Item | Standard |
|----------------|----------------------------|
| Axial end play | 0.05 mm (0.002 in) or less |

Drive Shaft

INFOID:0000000011220611

RAX

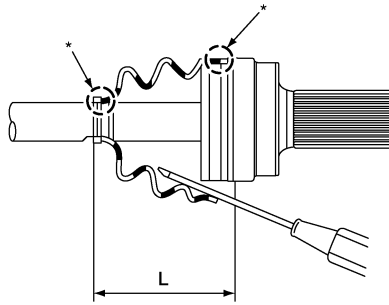

ALDIA0570ZZ

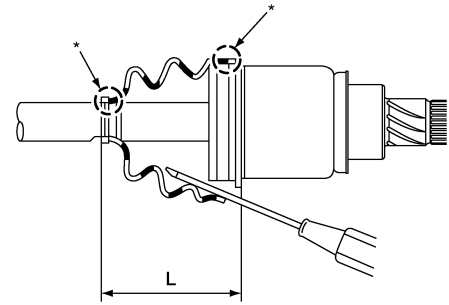

ALDIA0571ZZ

| Application | Standard | |
|-----------------------|----------------------------|----------------------------|
| Joint type | Wheel side | Final drive side |
| Grease quantity | 30 - 50 g (1.06 - 1.76 oz) | 45 - 50 g (1.59 - 1.76 oz) |
| Boot installed length | 67.7 mm (2.67 in) | 79.6 mm (3.13 in) |

* : Boot installation grooves