

A  
B  
C  
D  
E  
F  
G  
H  
I  
J  
K  
WW  
M  
N  
O  
P

# SECTION **WW**

## WIPER & WASHER

### CONTENTS

<p><b>PRECAUTION</b> ..... 3</p> <p><b>PRECAUTIONS</b> ..... 3</p> <p style="padding-left: 20px;">Precaution for Supplemental Restraint System (SRS) "AIR BAG" and "SEAT BELT PRE-TENSIONER" .....3</p> <p style="padding-left: 20px;">Precaution for Procedure without Cowl Top Cover.....3</p> <p style="padding-left: 20px;">Precaution for Work .....3</p> <p><b>PREPARATION</b> ..... 5</p> <p><b>PREPARATION</b> ..... 5</p> <p style="padding-left: 20px;">Special Service Tools .....5</p> <p><b>SYSTEM DESCRIPTION</b> ..... 6</p> <p><b>COMPONENT PARTS</b> ..... 6</p> <p style="padding-left: 20px;">Component Parts Location .....6</p> <p style="padding-left: 20px;">Front Wiper Motor .....7</p> <p style="padding-left: 20px;">Front and Rear Washer Motor .....7</p> <p style="padding-left: 20px;">Washer Fluid Level Switch .....8</p> <p style="padding-left: 20px;">Rear Wiper Motor .....8</p> <p><b>SYSTEM</b> ..... 9</p> <p><b>FRONT WIPER AND WASHER SYSTEM</b> .....9</p> <p style="padding-left: 20px;">FRONT WIPER AND WASHER SYSTEM : System Description .....9</p> <p style="padding-left: 20px;">FRONT WIPER AND WASHER SYSTEM : Fail-Safe ..... 11</p> <p><b>REAR WIPER AND WASHER SYSTEM</b> .....11</p> <p style="padding-left: 20px;">REAR WIPER AND WASHER SYSTEM : System Description ..... 12</p> <p style="padding-left: 20px;">REAR WIPER AND WASHER SYSTEM : Fail-Safe ..... 13</p> <p><b>DIAGNOSIS SYSTEM (BCM)</b> .....14</p> <p><b>COMMON ITEM</b> ..... 14</p> <p style="padding-left: 20px;">COMMON ITEM : CONSULT Function (BCM - COMMON ITEM) ..... 14</p>	<p><b>WIPER</b> .....15</p> <p style="padding-left: 20px;">WIPER : CONSULT Function (BCM - WIPER) .....15</p> <p><b>DIAGNOSIS SYSTEM (IPDM E/R)</b> .....17</p> <p style="padding-left: 20px;">Diagnosis Description .....17</p> <p style="padding-left: 20px;">CONSULT Function (IPDM E/R) .....18</p> <p><b>ECU DIAGNOSIS INFORMATION</b> .....21</p> <p><b>BCM, IPDM E/R</b> .....21</p> <p style="padding-left: 20px;">List of ECU Reference .....21</p> <p><b>WIRING DIAGRAM</b> .....22</p> <p><b>FRONT WIPER AND WASHER SYSTEM</b> .....22</p> <p style="padding-left: 20px;">Wiring Diagram .....22</p> <p><b>REAR WIPER AND WASHER SYSTEM</b> .....28</p> <p style="padding-left: 20px;">Wiring Diagram .....28</p> <p><b>BASIC INSPECTION</b> .....34</p> <p><b>DIAGNOSIS AND REPAIR WORKFLOW</b> .....34</p> <p style="padding-left: 20px;">Work Flow .....34</p> <p><b>DTC/CIRCUIT DIAGNOSIS</b> .....36</p> <p><b>WIPER AND WASHER FUSE</b> .....36</p> <p style="padding-left: 20px;">Diagnosis Procedure .....36</p> <p><b>FRONT WIPER MOTOR LO CIRCUIT</b> .....37</p> <p style="padding-left: 20px;">Component Function Check .....37</p> <p style="padding-left: 20px;">Diagnosis Procedure .....37</p> <p><b>FRONT WIPER MOTOR HI CIRCUIT</b> .....39</p> <p style="padding-left: 20px;">Component Function Check .....39</p> <p style="padding-left: 20px;">Diagnosis Procedure .....39</p> <p><b>FRONT WIPER STOP POSITION SIGNAL CIRCUIT</b> .....41</p> <p style="padding-left: 20px;">Component Function Check .....41</p> <p style="padding-left: 20px;">Diagnosis Procedure .....41</p>
---	---

<b>FRONT WIPER MOTOR GROUND CIRCUIT ...</b>	<b>42</b>	<b>FRONT WIPER ARM .....</b>	<b>62</b>
Diagnosis Procedure .....	42	Exploded View .....	62
<b>WASHER MOTOR CIRCUIT .....</b>	<b>43</b>	Removal and Installation .....	62
Diagnosis Procedure .....	43	Adjustment .....	62
<b>WASHER SWITCH .....</b>	<b>44</b>	<b>FRONT WIPER BLADE .....</b>	<b>64</b>
Description .....	44	Exploded View .....	64
Component Inspection .....	44	<b>FRONT WIPER BLADE .....</b>	<b>64</b>
<b>REAR WIPER MOTOR CIRCUIT .....</b>	<b>46</b>	FRONT WIPER BLADE : Removal and Installation .....	64
Component Function Check .....	46	<b>FRONT WIPER BLADE REFILL .....</b>	<b>64</b>
Diagnosis Procedure .....	46	FRONT WIPER BLADE REFILL : Removal and Installation .....	64
<b>REAR WIPER STOP POSITION SIGNAL CIRCUIT .....</b>	<b>48</b>	<b>FRONT WIPER DRIVE ASSEMBLY .....</b>	<b>68</b>
Component Function Check .....	48	Exploded View .....	68
Diagnosis Procedure .....	48	Removal and Installation .....	68
<b>SYMPTOM DIAGNOSIS .....</b>	<b>49</b>	<b>FRONT WIPER MOTOR .....</b>	<b>69</b>
<b>WIPER AND WASHER SYSTEM SYMPTOMS ...</b>	<b>49</b>	Exploded View .....	69
Symptom Table .....	49	Removal and Installation .....	69
<b>NORMAL OPERATING CONDITION .....</b>	<b>52</b>	<b>WIPER AND WASHER SWITCH .....</b>	<b>70</b>
Description .....	52	Removal and Installation .....	70
<b>FRONT WIPER DOES NOT OPERATE .....</b>	<b>53</b>	<b>REAR WIPER ARM .....</b>	<b>71</b>
Description .....	53	Exploded View .....	71
Diagnosis Procedure .....	53	Removal and Installation .....	71
<b>REMOVAL AND INSTALLATION .....</b>	<b>55</b>	Inspection .....	72
<b>WASHER TANK .....</b>	<b>55</b>	<b>REAR WIPER MOTOR .....</b>	<b>73</b>
Exploded View .....	55	Exploded View .....	73
Removal and Installation .....	55	Removal and Installation .....	73
<b>FRONT AND REAR WASHER MOTOR .....</b>	<b>57</b>	<b>REAR WASHER NOZZLE AND TUBE .....</b>	<b>74</b>
Exploded View .....	57	Washer Tube Layout .....	74
Removal and Installation .....	57	<b>REAR WASHER TUBE .....</b>	<b>74</b>
<b>WASHER FLUID LEVEL SWITCH .....</b>	<b>58</b>	REAR WASHER TUBE : Removal and Installation ...	74
Exploded View .....	58	REAR WASHER TUBE : Inspection .....	75
Removal and Installation .....	58	<b>REAR WASHER NOZZLE .....</b>	<b>75</b>
<b>FRONT WASHER NOZZLE AND TUBE .....</b>	<b>59</b>	REAR WASHER NOZZLE : Removal and Installation .....	75
Exploded View .....	59	<b>SERVICE DATA AND SPECIFICATIONS (SDS) .....</b>	<b>77</b>
<b>FRONT WASHER NOZZLE .....</b>	<b>59</b>	<b>SERVICE DATA AND SPECIFICATIONS (SDS) .....</b>	<b>77</b>
FRONT WASHER NOZZLE : Removal and Installation .....	59	Specifications .....	77
FRONT WASHER NOZZLE : Adjustment .....	60		
<b>FRONT WASHER TUBE .....</b>	<b>60</b>		
FRONT WASHER TUBE : Removal and Installation .....	61		

# PRECAUTIONS

< PRECAUTION >

## PRECAUTION

### PRECAUTIONS

#### Precaution for Supplemental Restraint System (SRS) "AIR BAG" and "SEAT BELT PRE-TENSIONER"

INFOID:000000011551993

The Supplemental Restraint System such as "AIR BAG" and "SEAT BELT PRE-TENSIONER", used along with a front seat belt, helps to reduce the risk or severity of injury to the driver and front passenger for certain types of collision. Information necessary to service the system safely is included in the SR and SB section of this Service Manual.

#### **WARNING:**

- To avoid rendering the SRS inoperative, which could increase the risk of personal injury or death in the event of a collision which would result in air bag inflation, all maintenance must be performed by an authorized NISSAN/INFINITI dealer.
- Improper maintenance, including incorrect removal and installation of the SRS, can lead to personal injury caused by unintentional activation of the system. For removal of Spiral Cable and Air Bag Module, see the SR section.
- Do not use electrical test equipment on any circuit related to the SRS unless instructed to in this Service Manual. SRS wiring harnesses can be identified by yellow and/or orange harnesses or harness connectors.

#### PRECAUTIONS WHEN USING POWER TOOLS (AIR OR ELECTRIC) AND HAMMERS

#### **WARNING:**

- When working near the Airbag Diagnosis Sensor Unit or other Airbag System sensors with the Ignition ON or engine running, DO NOT use air or electric power tools or strike near the sensor(s) with a hammer. Heavy vibration could activate the sensor(s) and deploy the air bag(s), possibly causing serious injury.
- When using air or electric power tools or hammers, always switch the Ignition OFF, disconnect the battery and wait at least three minutes before performing any service.

#### Precaution for Procedure without Cowl Top Cover

INFOID:000000011218037

When performing the procedure after removing cowl top cover, cover the lower end of windshield with urethane, etc to prevent damage to windshield.

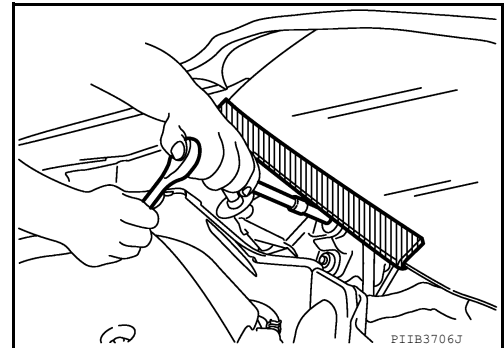

#### Precaution for Work

INFOID:000000011218038

- When removing or disassembling each component, be careful not to damage or deform it. If a component may be subject to interference, be sure to protect it with a shop cloth.
- When removing (disengaging) components with a screwdriver or similar tool, be sure to wrap the component with a shop cloth or vinyl tape to protect it.
- Protect the removed parts with a shop cloth and prevent them from being dropped.
- Replace a deformed or damaged clip.
- If a part is specified as a non-reusable part, always replace it with a new one.
- Be sure to tighten bolts and nuts securely to the specified torque.
- After installation is complete, be sure to check that each part works properly.
- Follow the steps below to clean components.
  - Water soluble dirt:
    - Dip a soft cloth into lukewarm water, wring the water out of the cloth and wipe the dirty area.
    - Then rub with a soft, dry cloth.
  - Oily dirt:

A

B

C

D

E

F

G

H

I

J

K

WW

M

N

O

P

## PRECAUTIONS

### < PRECAUTION >

---

- Dip a soft cloth into lukewarm water with mild detergent (concentration: within 2 to 3%) and wipe the dirty area.
- Then dip a cloth into fresh water, wring the water out of the cloth and wipe the detergent off.
- Then rub with a soft, dry cloth.
- Do not use organic solvent such as thinner, benzene, alcohol or gasoline.
- For genuine leather seats, use a genuine leather seat cleaner.

# PREPARATION

< PREPARATION >

## PREPARATION

### PREPARATION

#### Special Service Tools

INFOID:0000000011218039

The actual shape of the tools may differ from those illustrated here.

Tool number (TechMate No.) Tool name	Description
— (J-46534) Trim Tool Set	Removing trim components

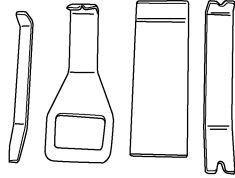

AWJIA0463ZZ

A  
B  
C  
D  
E  
F  
G  
H  
I  
J  
K  
M  
N  
O  
P

WW

# COMPONENT PARTS

< SYSTEM DESCRIPTION >

## SYSTEM DESCRIPTION

### COMPONENT PARTS

#### Component Parts Location

INFOID:000000011497422

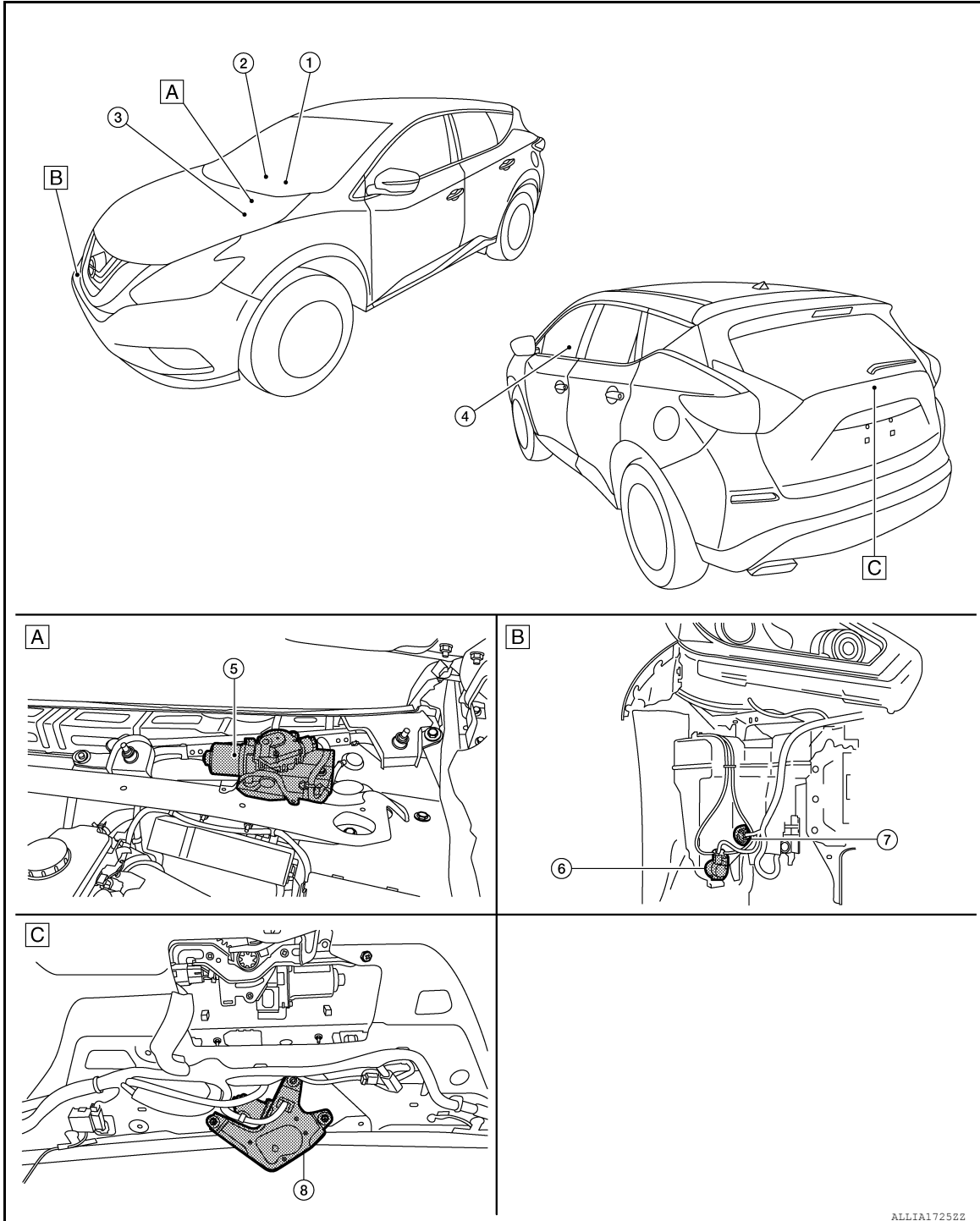

A. Cowl top (LH side)

B. Behind front bumper fascia (RH)

C. Back door lower finisher inside

# COMPONENT PARTS

## < SYSTEM DESCRIPTION >

No.	Part	Function
1.	Combination meter	Transmits the vehicle speed signal to BCM via CAN communication.
2.	Combination switch (wiper & washer switch)	Refer to <a href="#">BCS-8. "COMBINATION SWITCH READING SYSTEM : System Description"</a> for detailed installation location.
3.	IPDM E/R	<ul style="list-style-type: none"> <li>Controls the integrated relay according to the request (via CAN communication) from BCM.</li> <li>Performs the auto stop control of the front wiper.</li> <li>Refer to <a href="#">PCS-5. "Component Parts Location"</a> for detailed installation location.</li> </ul>
4.	BCM	<ul style="list-style-type: none"> <li>Judges the each switch status by the combination switch reading function.</li> <li>Requests (via CAN communication) the front wiper relay and the front wiper high relay ON to IPDM E/R.</li> <li>Supplies power to the rear wiper motor.</li> <li>Performs the auto stop control of the rear wiper.</li> <li>Refer to <a href="#">BCS-4. "BODY CONTROL SYSTEM : Component Parts Location"</a> for detailed installation location.</li> </ul>
5.	Front wiper motor	Refer to component below.
6.	Front and rear washer motor	Refer to component below.
7.	Washer fluid level switch	Refer to component below.
8.	Rear wiper motor	Refer to component below.

### Front Wiper Motor

INFOID:000000011504349

- Controls front wiper operation with IPDM E/R control.
- Transmits front wiper stop position signal to IPDM E/R.

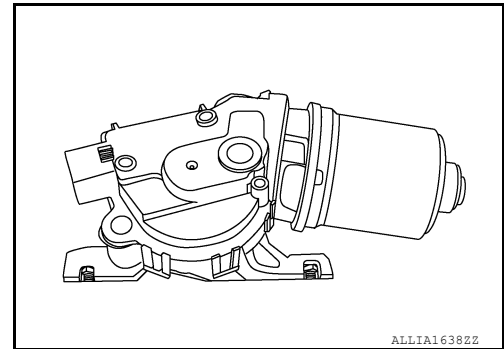

### Front and Rear Washer Motor

INFOID:000000011504350

- Washer fluid is sprayed according to washer switch status.
- Switching between front washer and rear washer is performed according to the voltage polarity change to washer pump.

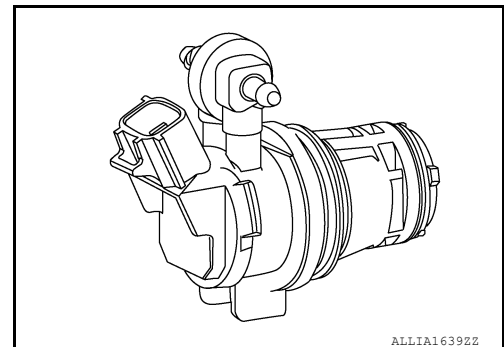

A  
B  
C  
D  
E  
F  
G  
H  
I  
J  
K  
WW  
M  
N  
O  
P

## COMPONENT PARTS

### < SYSTEM DESCRIPTION >

#### Washer Fluid Level Switch

INFOID:000000011504351

Detects that washer fluid level is low and transmits washer fluid level switch signal to combination meter.

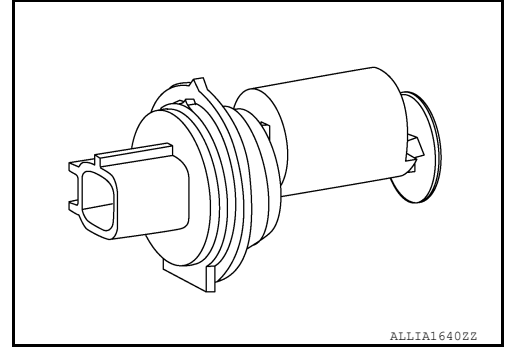

#### Rear Wiper Motor

INFOID:000000011504352

- Controls rear wiper operation with BCM control.
- Transmits rear wiper stop position signal to BCM.

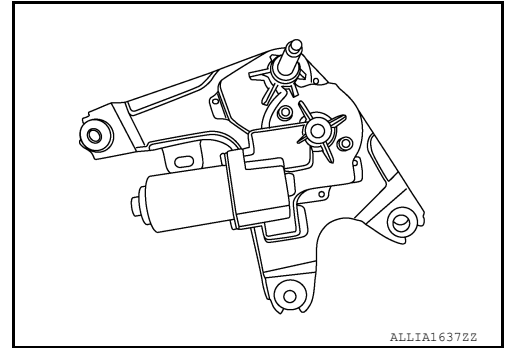



# SYSTEM

< SYSTEM DESCRIPTION >

## SYSTEM

### FRONT WIPER AND WASHER SYSTEM

#### FRONT WIPER AND WASHER SYSTEM : System Description

INFOID:000000011218047

#### SYSTEM DIAGRAM

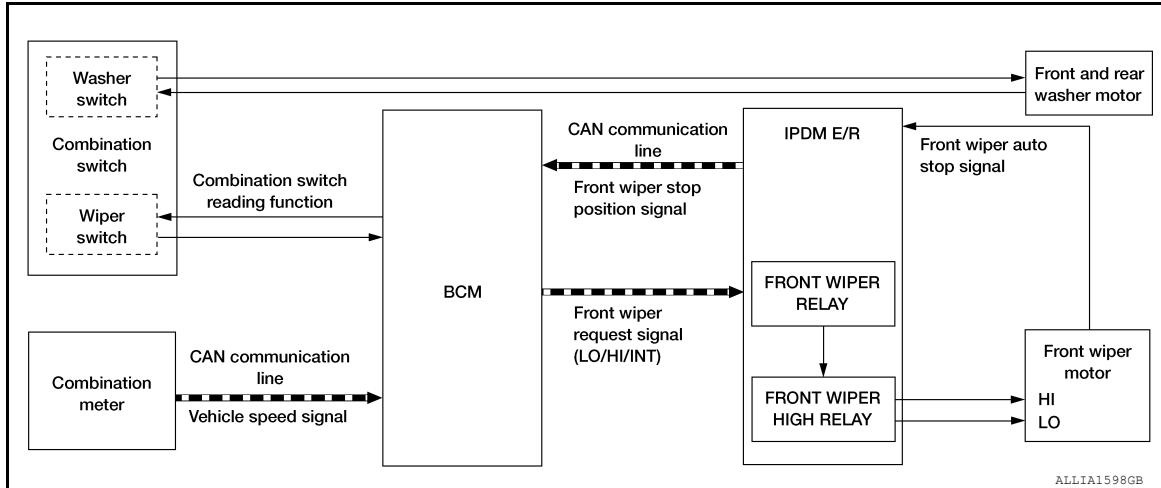

#### OUTLINE

The front wiper is controlled by each function of BCM and IPDM E/R.

Control by BCM:

- Combination switch reading function
- Front wiper control function

Control by IPDM E/R:

- Front wiper control function
- Relay control function

Combination meter indicates low washer fluid warning judged with the signal from the washer level switch. For details of low washer fluid warning, refer to [MWI-15. "INFORMATION DISPLAY : System Description"](#).

#### FRONT WIPER BASIC OPERATION

- BCM detects the combination switch condition by the combination switch reading function.
- BCM transmits the front wiper request signal to IPDM E/R with CAN communication depending on each operating condition of the front wiper.
- IPDM E/R turns ON/OFF the integrated front wiper relay and the front wiper high relay according to the front wiper request signal. IPDM E/R provides the power supply to operate the front wiper HI/LO operation.

#### FRONT WIPER LO OPERATION

- BCM transmits the front wiper request signal (LO) to IPDM E/R with CAN communication according to the front wiper LO operating condition.

Front wiper LO operating condition:

- Ignition switch ON
- Front wiper switch LO or front wiper switch MIST (while pressing)
- IPDM E/R turns ON the integrated front wiper relay according to the front wiper request signal (LO).

#### FRONT WIPER HI OPERATION

- BCM transmits the front wiper request signal (HI) to IPDM E/R with CAN communication according to the front wiper HI operating condition.

Front wiper HI operating condition:

- Ignition switch ON
- Front wiper switch HI
- IPDM E/R turns ON the integrated front wiper relay and the front wiper high relay according to the front wiper request signal (HI).

#### FRONT WIPER INT OPERATION

A  
B  
C  
D  
E  
F  
G  
H  
I  
J  
K  
M  
N  
O  
P

WW

# SYSTEM

## < SYSTEM DESCRIPTION >

- BCM transmits the front wiper request signal (INT) to IPDM E/R with CAN communication depending on the front wiper INT operating condition and intermittent operation delay interval according to the wiper intermittent dial position.

Front wiper INT operating condition:

- Ignition switch ON
- Front wiper switch INT
- IPDM E/R turns ON the integrated front wiper relay so that the front wiper is operated only once according to the front wiper request signal (INT).
- BCM detects stop position/except stop position of the front wiper motor according to the front wiper stop position signal received from IPDM E/R with CAN communication.
- BCM transmits the front wiper request signal (INT) again after the intermittent operation delay interval.

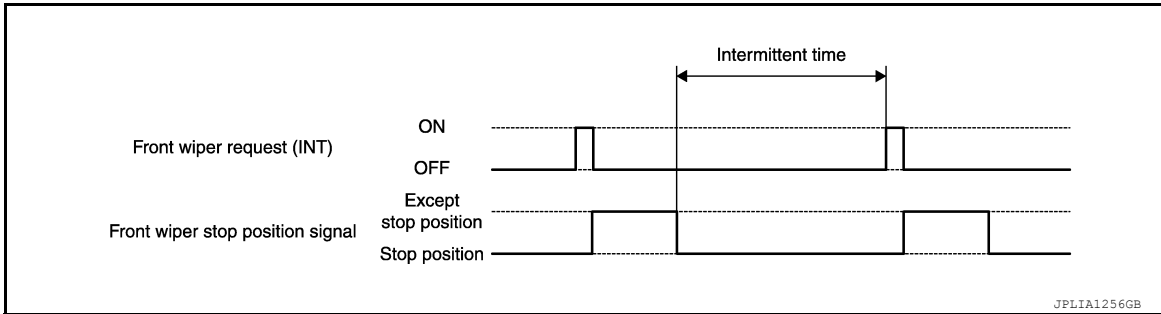

### NOTE:

Factory setting of the front wiper intermittent operation is without speed dependant function. Front wiper speed dependant function can be set in the vehicle settings of the Vehicle Information Display.

Front wiper intermittent operation with vehicle speed

- BCM calculates the intermittent operation delay interval from the following:
  - Vehicle speed signal (received from the combination meter with CAN communication)
  - Wiper intermittent dial position

Wiper intermittent dial position	Intermittent operation interval	Intermittent operation delay Interval (s)			
		Vehicle speed			
		0 – 5 km/h (0 – 3.1 MPH)	5 – 35 km/h (3.1 – 21.7 MPH)	35 – 65 km/h* (21.7 – 40 MPH)	65 km/h (40.4 MPH) or more
1	Short ↑	0.8	0.6	0.4	0.24
2		4	3	2	1.2
3		10	7.5	5	3
4		16	12	8	4.8
5		24	18	12	7.2
6	↓ Long	32	24	16	9.6
7		42	31.5	21	12.6

\*: When without vehicle speed setting

### FRONT WIPER AUTO STOP OPERATION

- BCM stops transmitting the front wiper request signal when the front wiper switch is turned OFF.
- IPDM E/R detects the front wiper stop position signal from the front wiper motor and detects the front wiper motor position (stop position/except stop position).

# SYSTEM

## < SYSTEM DESCRIPTION >

- When the front wiper request signal is stopped, IPDM E/R turns ON the front wiper relay until the front wiper motor returns to the stop position.

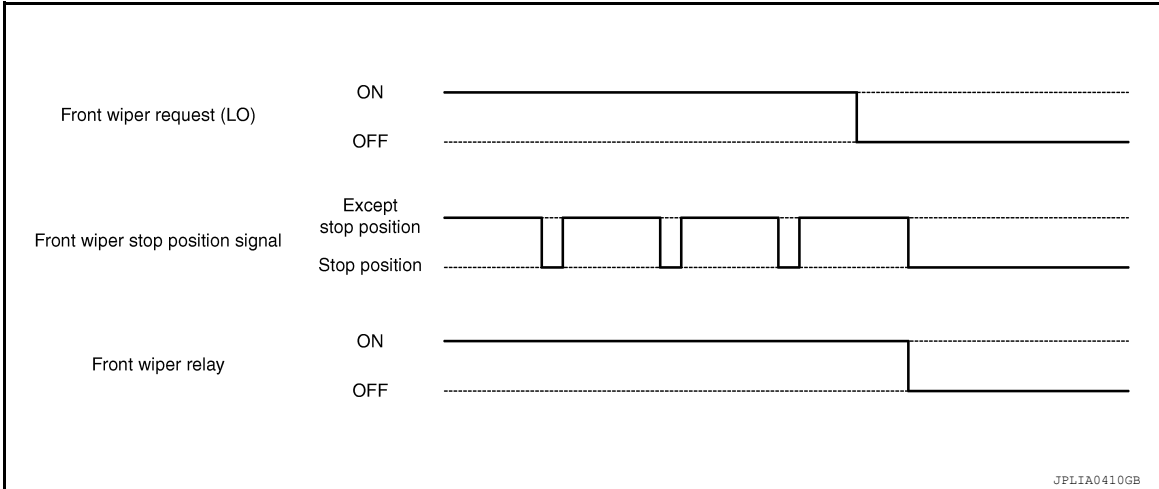

### NOTE:

- BCM stops the transmitting of the front wiper request signal when the ignition switch is OFF.
- IPDM E/R turns the front wiper relay OFF when the ignition switch is OFF.

### FRONT WIPER OPERATION LINKED WITH WASHER

- BCM transmits the front wiper request signal (LO) to IPDM E/R with CAN communication according to the washer linked operating condition of the front wiper.
- BCM transmits the front wiper request signal (LO) so that the front wiper operates approximately two times when the front washer switch OFF is detected.

Washer linked operating condition of front wiper:

- Ignition switch ON
- Front washer switch ON (0.4 seconds or more)
- IPDM E/R turns ON the integrated front wiper relay according to the front wiper request signal (LO).
- The washer pump is grounded through the combination switch with the front washer switch ON.

### FRONT WIPER FAIL-SAFE OPERATION

IPDM E/R performs the fail-safe function when the front wiper stop position circuit is malfunctioning.

### FRONT WIPER AND WASHER SYSTEM : Fail-Safe

INFOID:000000011218048

### FAIL-SAFE OPERATION

IPDM E/R performs the fail-safe function when the front wiper auto stop circuit is malfunctioning. Refer to [PCS-20. "Fail Safe"](#).

### REAR WIPER AND WASHER SYSTEM

A  
B  
C  
D  
E  
F  
G  
H  
I  
J  
K  
WW  
M  
N  
O  
P

# SYSTEM

< SYSTEM DESCRIPTION >

## REAR WIPER AND WASHER SYSTEM : System Description

INFOID:000000011218053

### SYSTEM DIAGRAM

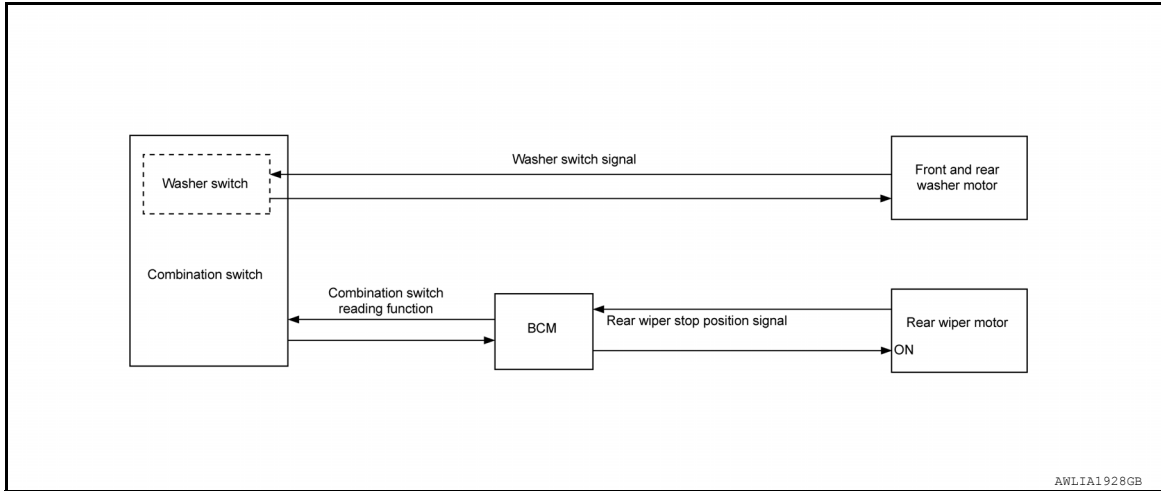

### OUTLINE

The rear wiper is controlled by each function of BCM.

Control by BCM:

- Combination switch reading function
- Rear wiper control function

### REAR WIPER BASIC OPERATION

- BCM detects the combination switch condition by the combination switch reading function.
- BCM controls the rear wiper to start or stop.

### REAR WIPER ON OPERATION

- BCM supplies power to the rear wiper motor according to the rear wiper ON operating condition.

Rear wiper ON operating condition:

- Ignition switch ON
- Rear wiper switch ON

### REAR WIPER INT OPERATION

- BCM supplies power to the rear wiper motor according to the INT operating condition.

Rear wiper INT operating condition:

- Ignition switch ON
- Rear wiper switch INT
- BCM controls the rear wiper to operate once.
- BCM detects the rear wiper motor stop position.
- BCM supplies power to the rear wiper motor after an intermittent from the stop of the rear wiper motor.

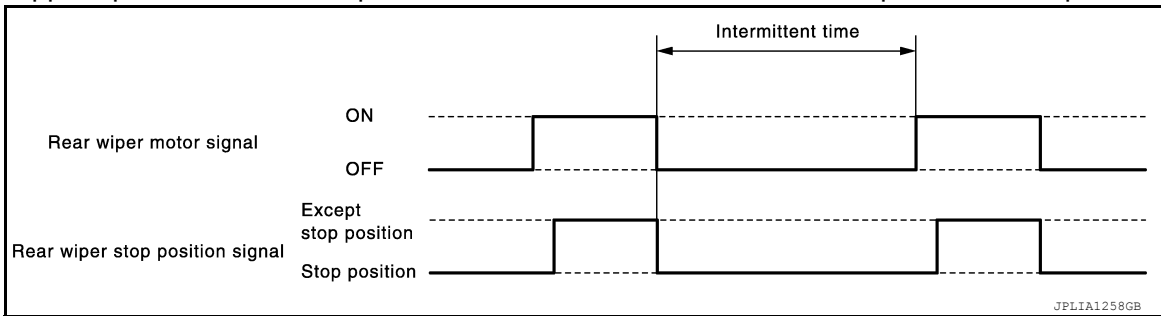

### REAR WIPER AUTO STOP OPERATION

- BCM stops supplying power to the rear wiper motor when the rear wiper switch is turned OFF.
- BCM reads a rear wiper stop position signal from the rear wiper motor to detect a rear wiper motor position.

# SYSTEM

## < SYSTEM DESCRIPTION >

- When the rear wiper motor is at other than the stop position, BCM continues to supply power to the rear wiper motor until it returns to the stop position.

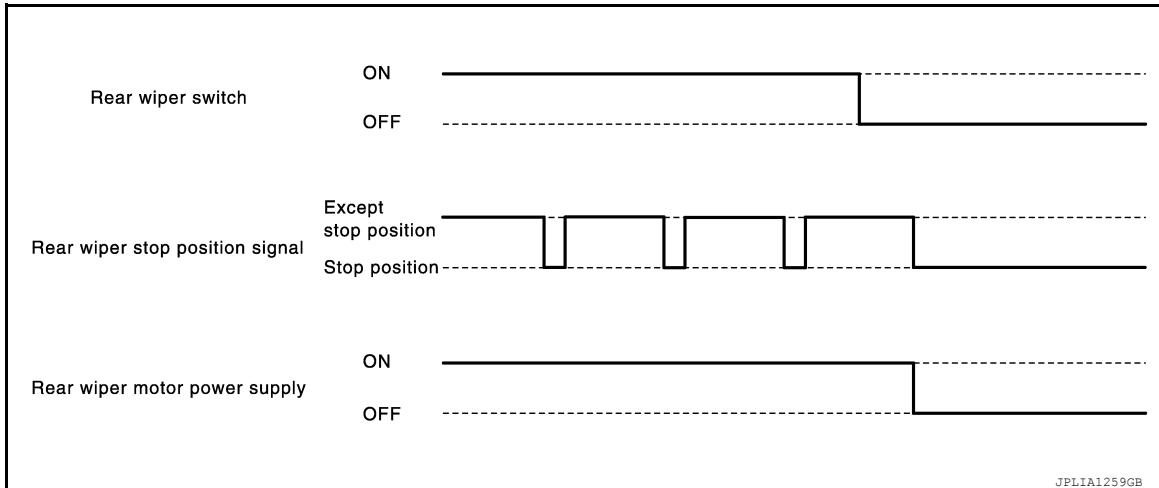

### NOTE:

BCM stops supplying power to the rear wiper motor when the ignition switch is turned OFF.

### REAR WIPER OPERATION LINKED WITH WASHER

- BCM supplies power to the rear wiper motor according to the washer linked operating condition of the rear wiper. When the rear washer switch is turned OFF, BCM controls the rear wiper to operate approximately three times.

Washer linked operating condition of the rear wiper:

- Ignition switch ON
- Rear washer switch ON (0.4 seconds or more)
- The washer pump is grounded through the combination switch with the rear washer switch ON.

### REAR WIPER DROP WIPE OPERATION

- BCM controls the rear wiper to operate once according to the rear wiper drop wipe operating condition.

Rear wiper drop wipe operating condition:

- Ignition switch ON
- Rear wiper switch OFF
- Rear washer switch OFF
- BCM controls the rear wiper so that it operates once approximately three seconds later after the washer interlocking operation of the rear wiper.

### NOTE:

Factory setting of the rear wiper drop wipe operation is OFF. Rear wiper drop wipe operation can be set to ON or OFF using CONSULT. Refer to [BCS-20, "WIPER : CONSULT Function \(BCM - WIPER\)"](#).

### REAR WIPER AND WASHER SYSTEM : Fail-Safe

INFOID:0000000011218054

### FAIL-SAFE OPERATION

IPDM E/R performs the fail-safe function when the front wiper auto stop circuit is malfunctioning. Refer to [PCS-20, "Fail Safe"](#).

A  
B  
C  
D  
E  
F  
G  
H  
I  
J  
K  
M  
N  
O  
P

WW

## DIAGNOSIS SYSTEM (BCM)

< SYSTEM DESCRIPTION >

### DIAGNOSIS SYSTEM (BCM)

#### COMMON ITEM

COMMON ITEM : CONSULT Function (BCM - COMMON ITEM)

INFOID:000000011497473

#### APPLICATION ITEM

CONSULT performs the following functions via CAN communication with BCM.

Direct Diagnostic Mode	Description
ECU Identification	The BCM part number is displayed.
Self Diagnostic Result	The BCM self diagnostic results are displayed.
Data Monitor	The BCM input/output data is displayed in real time.
Active Test	The BCM activates outputs to test components.
Work support	The settings for BCM functions can be changed.
Configuration	<ul style="list-style-type: none"> <li>• The vehicle specification can be read and saved.</li> <li>• The vehicle specification can be written when replacing BCM.</li> </ul>
CAN Diag Support Mntr	The result of transmit/receive diagnosis of CAN communication is displayed.

#### SYSTEM APPLICATION

BCM can perform the following functions:

System	Sub System	Direct Diagnostic Mode						
		ECU Identification	Self Diagnostic Result	Data Monitor	Active Test	Work support	Configuration	CAN Diag Support Mntr
Door lock	DOOR LOCK		×	×	×	×		
Rear window defogger	REAR DEFOGGER			×	×	×		
Warning chime	BUZZER			×	×			
Interior room lamp timer	INT LAMP			×	×	×		
Exterior lamp	HEADLAMP			×	×	×		
Wiper and washer	WIPER			×	×	×		
Turn signal and hazard warning lamps	FLASHER			×	×	×		
Air conditioner	AIR CONDITIONER			×				
Intelligent Key system	INTELLIGENT KEY		×	×	×	×		
Combination switch	COMB SW			×				
BCM	BCM	×	×			×	×	×
Immobilizer	IMMU		×	×	×			
Interior room lamp battery saver	BATTERY SAVER			×	×			
Back door open	TRUNK			×				
Vehicle security system	THEFT ALM			×	×	×		
RAP system	RETAINED PWR			×				
Signal buffer system	SIGNAL BUFFER			×	×			
TPMS	AIR PRESSURE MONITOR		×	×	×			

#### FREEZE FRAME DATA (FFD)

# DIAGNOSIS SYSTEM (BCM)

## < SYSTEM DESCRIPTION >

The BCM records the following vehicle condition at the time a particular DTC is detected, and displays it on CONSULT.

CONSULT screen item	Indication/Unit	Description
Vehicle Speed	km/h	Vehicle speed at the moment a particular DTC is detected
Odo/Trip Meter	km	Total mileage (Odometer value) at the moment a particular DTC is detected
Vehicle Condition	SLEEP>LOCK	While turning BCM status from low power consumption mode to normal mode (Power supply position is "LOCK"*).
	SLEEP>OFF	While turning BCM status from low power consumption mode to normal mode (Power supply position is "OFF".)
	LOCK>ACC	While turning power supply position from "LOCK"*to "ACC"
	ACC>ON	While turning power supply position from "ACC" to "IGN"
	RUN>ACC	While turning power supply position from "RUN" to "ACC" (Vehicle is stopped and selector lever is in P position.)
	CRANK>RUN	While turning power supply position from "CRANKING" to "RUN" (From cranking up the engine to run it)
	RUN>URGENT	While turning power supply position from "RUN" to "ACC" (Emergency stop operation)
	ACC>OFF	While turning power supply position from "ACC" to "OFF"
	OFF>LOCK	While turning power supply position from "OFF" to "LOCK"*
	OFF>ACC	While turning power supply position from "OFF" to "ACC"
	ON>CRANK	While turning power supply position from "IGN" to "CRANKING"
	OFF>SLEEP	While turning BCM status from normal mode (Power supply position is "OFF".) to low power consumption mode
	LOCK>SLEEP	While turning BCM status from normal mode (Power supply position is "LOCK"*. ) to low power consumption mode
	LOCK	Power supply position is "LOCK" (Ignition switch OFF)*
	OFF	Power supply position is "OFF" (Ignition switch OFF)
	ACC	Power supply position is "ACC" (Ignition switch ACC)
	ON	Power supply position is "IGN" (Ignition switch ON with engine stopped)
ENGINE RUN	Power supply position is "RUN" (Ignition switch ON with engine running)	
CRANKING	Power supply position is "CRANKING" (At engine cranking)	
IGN Counter	0 - 39	<p>The number of times that ignition switch is turned ON after DTC is detected</p> <ul style="list-style-type: none"> <li>• The number is 0 when a malfunction is detected now.</li> <li>• The number increases like 1 → 2 → 3...38 → 39 after returning to the normal condition whenever ignition is switched OFF → ON.</li> <li>• The number is fixed to 39 until the self-diagnosis results are erased if it is over 39.</li> </ul>

### NOTE:

\*: Power supply position shifts to "LOCK" from "OFF", when ignition switch is in the OFF position, selector lever is in the P position, and any of the following conditions are met:

- Closing door
- Opening door
- Door is locked using door request switch
- Door is locked using Intelligent Key

The power supply position shifts to "ACC" when the push-button ignition switch (push switch) is pushed at "LOCK".

## WIPER

### WIPER : CONSULT Function (BCM - WIPER)

INFOID:0000000011497474

### DATA MONITOR

## DIAGNOSIS SYSTEM (BCM)

### < SYSTEM DESCRIPTION >

Monitor Item [Unit]	Description
PUSH SW [On/Off]	Indicates condition of push-button ignition switch.
VEH SPEED 1 [km/h]	Indicates vehicle speed signal received from ABS on CAN communication line.
FR WIPER HI [On/Off]	Indicates condition of wiper operation of combination switch.
FR WIPER LOW [On/Off]	
FR WASHER SW [On/Off]	
FR WIPER INT [On/Off]	
FR WIPER STOP [On/Off]	
FR WIPER STOP [On/Off]	Indicates front wiper auto stop signal received from IPDM E/R on CAN communication line.
INT VOLUME [1 - 7]	Indicates condition of intermittent wiper operation of combination switch.
RR WIPER ON [On/Off]	Indicates condition of rear wiper operation of combination switch.
RR WIPER INT [On/Off]	
RR WASHER SW [On/Off]	
RR WIPER STOP [On/Off]	
RR WIPER STOP [On/Off]	Indicates rear wiper motor auto stop input from rear wiper motor.

### ACTIVE TEST

Test Item	Description
FR WIPER	This test is able to check front wiper operation [Hi/Lo/INT/Off].
RR WIPER	This test is able to check rear wiper operation [On/Off].

### WORK SUPPORT

Support Item	Setting	Description
WIPER SPEED SETTING	On	Front wiper intermittent time linked with vehicle speed and wiper dial position.
	Off*	Front wiper intermittent time linked with wiper dial position.

\* : Initial setting



# DIAGNOSIS SYSTEM (IPDM E/R)

< SYSTEM DESCRIPTION >

## DIAGNOSIS SYSTEM (IPDM E/R)

### Diagnosis Description

INFOID:000000011497475

### AUTO ACTIVE TEST

#### Description

In auto active test mode, the IPDM E/R sends a drive signal to the following systems to check their operation:

- Front wiper (LO, HI)
- Front fog lamps
- Parking lamps
- Side marker lamps
- Tail lamps
- License plate lamps
- Daytime running lamps
- Headlamps (LO, HI)
- A/C compressor
- Cooling fans (LO, HI)

#### Operation Procedure

#### **CAUTION:**

**Do not start the engine.**

#### **NOTE:**

When auto active test is performed with hood opened, sprinkle water on windshield before hand.

#### **NOTE:**

- If auto active test mode cannot be actuated, check door switch system. Refer to [DLK-179, "Component Function Check"](#).
  - When auto active test mode has to be cancelled halfway through test, turn ignition switch OFF.
1. Close the hood and lift the wiper arms from the windshield. (Prevent windshield damage due to wiper operation)
  2. Turn ignition switch OFF.
  3. Turn the ignition switch ON, and within 20 seconds, press the front door switch LH 10 times. Then turn the ignition switch OFF.
  4. Turn the ignition switch ON within 10 seconds. After that the horn sounds once, and the auto active test starts.
  5. After a series of the following operations is repeated 3 times, auto active test is completed.

#### Inspection in Auto Active Test Mode

When auto active test mode is actuated, the following operation sequence is repeated 3 times.

Operation sequence	Inspection Location	Operation
1	Front wiper	LO for 3 seconds → HI for 3 seconds
2	<ul style="list-style-type: none"><li>• Front fog lamps</li><li>• Parking lamps</li><li>• Side marker lamps</li><li>• Tail lamps</li><li>• License plate lamps</li></ul>	10 seconds
3	Daytime running lamps	10 seconds
4	Headlamps	LO ⇔ HI 5 times
5	A/C compressor	ON ⇔ OFF 5 times
6*	Cooling fans	LO for 5 seconds → HI for 5 seconds

\*: Outputs duty ratio of 50% for 5 seconds → duty ratio of 100% for 5 seconds on the cooling fan control module.

# DIAGNOSIS SYSTEM (IPDM E/R)

## < SYSTEM DESCRIPTION >

### Concept of auto active test

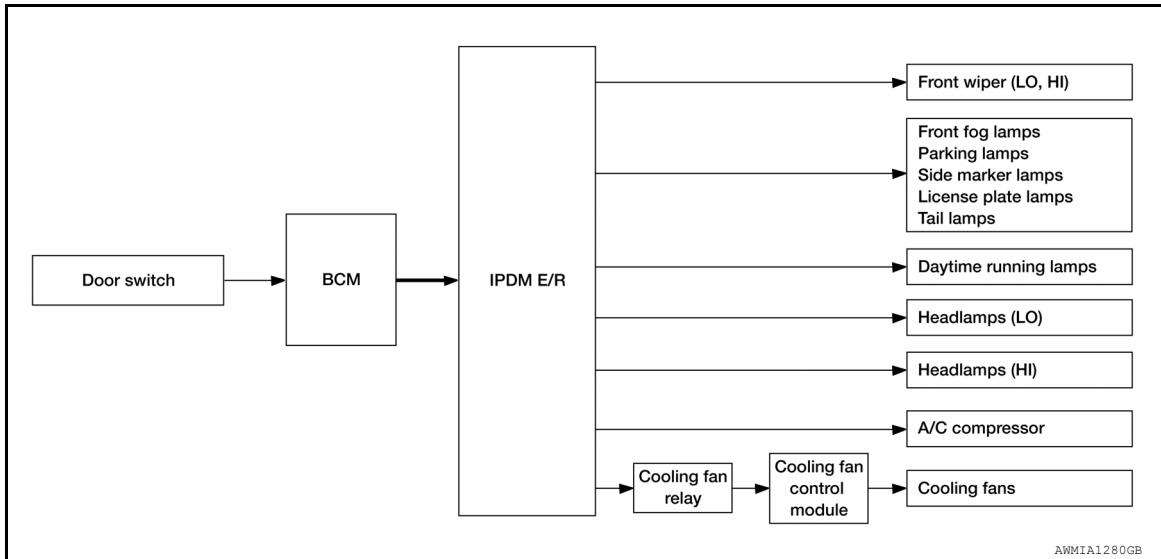

- IPDM E/R starts the auto active test with the door switch signals transmitted by BCM via CAN communication. Therefore, the CAN communication line between IPDM E/R and BCM is considered normal if the auto active test starts successfully.
- The auto active test facilitates troubleshooting if any systems controlled by IPDM E/R cannot be operated.

### Diagnosis chart in auto active test mode

Symptom	Inspection contents	Possible cause
Any of the following components do not operate • Front fog lamps • Parking lamps • Side marker lamps • License plate lamps • Tail lamps • Daytime running lamps • Headlamp (HI, LO) • Front wiper	Perform auto active test. Does the applicable system operate?	YES BCM signal input circuit
		NO • Lamp or motor • Lamp or motor ground circuit • Harness or connector between IPDM E/R and applicable system • IPDM E/R
Cooling fans do not operate	Perform auto active test. Do the cooling fans operate?	YES • ECM signal input circuit • CAN communication signal between ECM and IPDM E/R
		NO • Cooling fans • Harness or connectors between cooling fans and cooling fan control module • Cooling fan control module • Harness or connectors between cooling fan relay and cooling fan control module • Cooling fan relay • Harness or connectors between IPDM E/R and cooling fan relay • IPDM E/R

## CONSULT Function (IPDM E/R)

INFOID:000000011497476

### CAUTION:

After disconnecting the CONSULT vehicle interface (VI) from the data link connector, the ignition must be cycled OFF → ON (for at least 5 seconds) → OFF. If this step is not performed, the BCM may not go to "sleep mode", potentially causing a discharged battery and a no-start condition.

# DIAGNOSIS SYSTEM (IPDM E/R)

## < SYSTEM DESCRIPTION >

### APPLICATION ITEM

CONSULT performs the following functions via CAN communication with IPDM E/R.

Direct Diagnostic Mode	Description
ECU Identification	The IPDM E/R part number is displayed.
Self Diagnostic Result	The IPDM E/R self diagnostic results are displayed.
Data Monitor	The IPDM E/R input/output data is displayed in real time.
Active Test	The IPDM E/R activates outputs to test components.

### ECU IDENTIFICATION

The IPDM E/R part number is displayed.

### SELF DIAGNOSTIC RESULT

Refer to [PCS-21, "DTC Index"](#).

### DATA MONITOR

Monitor Item [Unit]	Main Signals	Description
MOTOR FAN REQ [%]	×	Indicates cooling fan speed signal received from ECM on CAN communication line.
AC COMP REQ [On/Off]	×	Indicates A/C compressor request signal received from ECM on CAN communication line.
TAIL&CLR REQ [On/Off]	×	Indicates position light request signal received from BCM on CAN communication line.
HL LO REQ [On/Off]	×	Indicates low beam request signal received from BCM on CAN communication line.
HL HI REQ [On/Off]	×	Indicates high beam request signal received from BCM on CAN communication line.
FR FOG REQ [On/Off]	×	Indicates front fog light request signal received from BCM on CAN communication line.
FR WIP REQ [Stop/1LOW/Low/Hi]	×	Indicates front wiper request signal received from BCM on CAN communication line.
WIP AUTO STOP [STOP P/ACT P]	×	Indicates condition of front wiper auto stop signal.
WIP PROT [Off/BLOCK]	×	Indicates condition of front wiper fail-safe operation.
IGN RLY1 -REQ [On/Off]		Indicates ignition switch ON signal received from BCM on CAN communication line.
IGN RLY [On/Off]	×	Indicates condition of ignition relay.
PUSH SW [On/Off]		Indicates condition of push-button ignition switch.
INTER/NP SW [On/Off]		Indicates condition of CVT shift position.
ST RLY CONT [On/Off]		Indicates starter relay status signal received from BCM on CAN communication line.
IHBT RLY -REQ [On/Off]		Indicates starter control relay signal received from BCM on CAN communication line.
ST/INH RLY [Off/ ST /INH]		Indicates condition of starter relay and starter control relay.
DETENT SW [On/Off]		Indicates condition of CVT shift selector (park position switch).
DTRL REQ [Off]		Indicates daytime light request signal received from BCM on CAN communication line.
HOOD SW [On/Off]		Indicates condition of hood switch.
THFT HRN REQ [On/Off]		Indicates theft warning horn request signal received from BCM on CAN communication line.
HORN CHIRP [On/Off]		Indicates horn reminder signal received from BCM on CAN communication line.
HOOD SW 2 [On/Off]		Indicates condition of hood switch 2.

## DIAGNOSIS SYSTEM (IPDM E/R)

< SYSTEM DESCRIPTION >

### ACTIVE TEST

Test item	Description
HORN	This test is able to check horn operation [On].
FRONT WIPER	This test is able to check wiper motor operation [Hi/Lo/Off].
MOTOR FAN	This test is able to check cooling fan operation [4/3/2/1].
EXTERNAL LAMPS	This test is able to check external lamp operation [Fog/Hi/Lo/Tail/Off].

# BCM, IPDM E/R

< ECU DIAGNOSIS INFORMATION >

## ECU DIAGNOSIS INFORMATION

BCM, IPDM E/R

List of ECU Reference

INFOID:0000000011218059

ECU	Reference
BCM	<a href="#">BCS-30. "Reference Value"</a>
	<a href="#">BCS-50. "Fail Safe"</a>
	<a href="#">BCS-51. "DTC Inspection Priority Chart"</a>
	<a href="#">BCS-52. "DTC Index"</a>
IPDM E/R	<a href="#">PCS-13. "Reference Value"</a>
	<a href="#">PCS-20. "Fail Safe"</a>
	<a href="#">PCS-21. "DTC Index"</a>

A  
B  
C  
D  
E  
F  
G  
H  
I  
J  
K  
M  
N  
O  
P

WW

# FRONT WIPER AND WASHER SYSTEM

< WIRING DIAGRAM >

## WIRING DIAGRAM

### FRONT WIPER AND WASHER SYSTEM

Wiring Diagram

INFOID:000000011218060

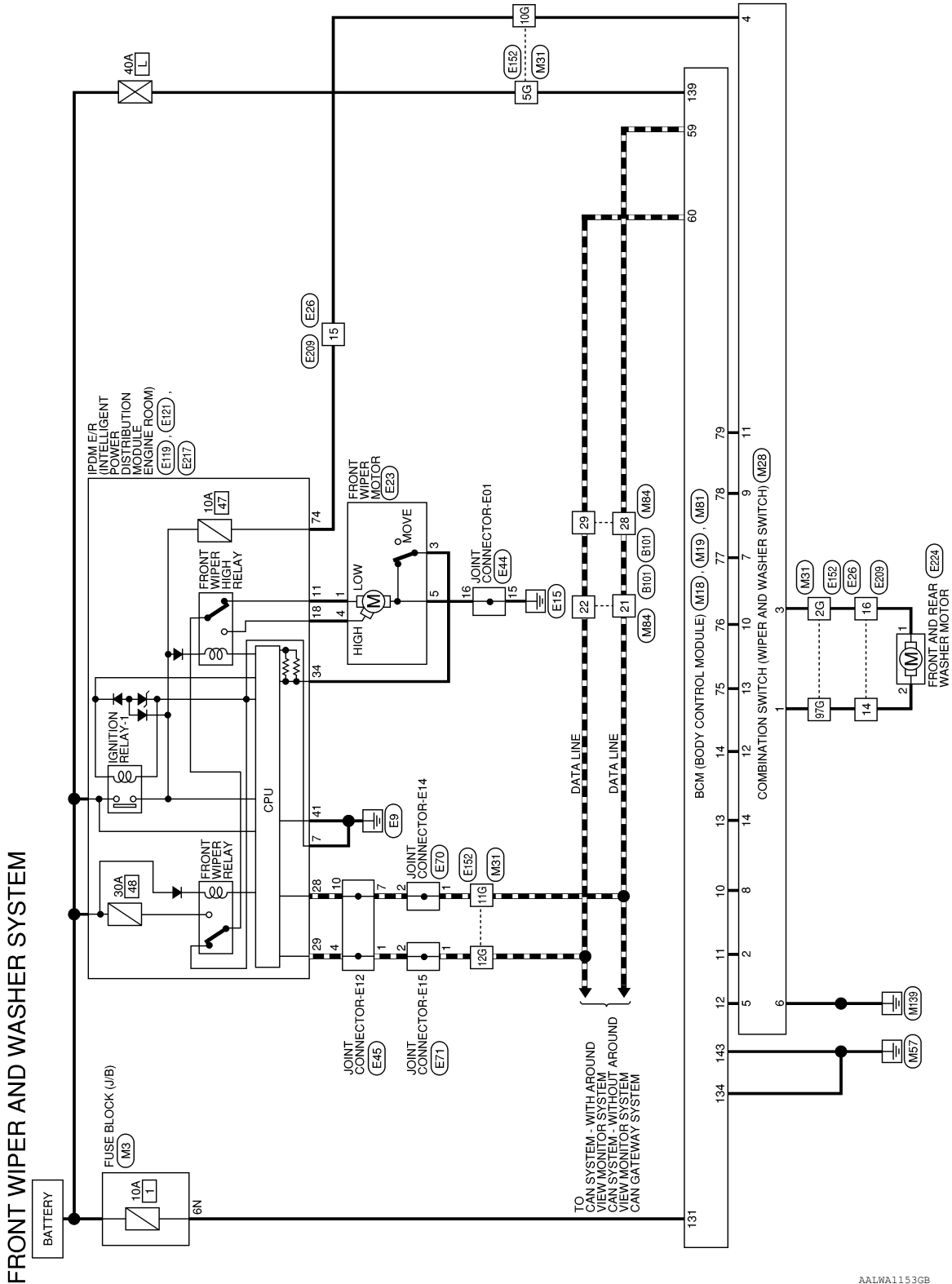

AALWA1153GB

# FRONT WIPER AND WASHER SYSTEM

< WIRING DIAGRAM >

## FRONT WIPER AND WASHER SYSTEM CONNECTORS

Connector No.	M3
Connector Name	FUSE BLOCK (J/B)
Connector Color	WHITE

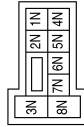

Terminal No.	Color of Wire	Signal Name
6N	W	-

Connector No.	M18
Connector Name	BCM (BODY CONTROL MODULE)
Connector Color	GREEN

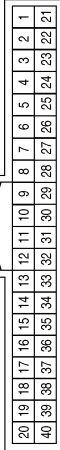

Terminal No.	Color of Wire	Signal Name
10	W	COMBI SW OUT 5
11	BG	COMBI SW OUT 4
12	R	COMBI SW OUT 3
13	G	COMBI SW OUT 2
14	P	COMBI SW OUT 1

Connector No.	M19
Connector Name	BCM (BODY CONTROL MODULE)
Connector Color	BLACK

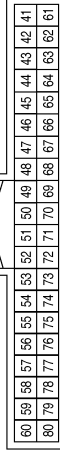

Terminal No.	Color of Wire	Signal Name
59	P	CAN-L
60	L	CAN-H
75	BG	COMBI SW IN 5
76	P	COMBI SW IN 4
77	R	COMBI SW IN 3
78	G	COMBI SW IN 2
79	W	COMBI SW IN 1

Connector No.	M28
Connector Name	COMBINATION SWITCH (WIPER AND WASHER SWITCH)
Connector Color	WHITE

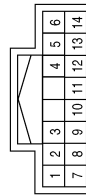

Terminal No.	Color of Wire	Signal Name
1	LG	-
2	BG	-
3	Y	-
4	Y	-
5	R	-

Terminal No.	Color of Wire	Signal Name
6	GR	-
7	R	-
8	W	-
9	G	-
10	P	-
11	W	-
12	P	-
13	BG	-
14	G	-

AALIA3018GB

A  
B  
C  
D  
E  
F  
G  
H  
I  
J  
K  
L  
M  
N  
O  
P

WW

# FRONT WIPER AND WASHER SYSTEM

< WIRING DIAGRAM >

Connector No.	M84
Connector Name	WIRE TO WIRE
Connector Color	WHITE

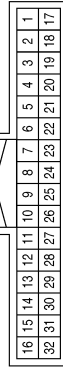

Terminal No.	Color of Wire	Signal Name
21	P	-
22	L	-
28	P	-
29	L	-

Connector No.	M81
Connector Name	BCM (BODY CONTROL MODULE)
Connector Color	WHITE

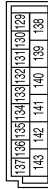

Terminal No.	Color of Wire	Signal Name
131	W	BAT BCM FUSE
134	GR	GND 2
139	L	BAT POWER F/L
143	GR	GND 1

Connector No.	M31
Connector Name	WIRE TO WIRE
Connector Color	WHITE

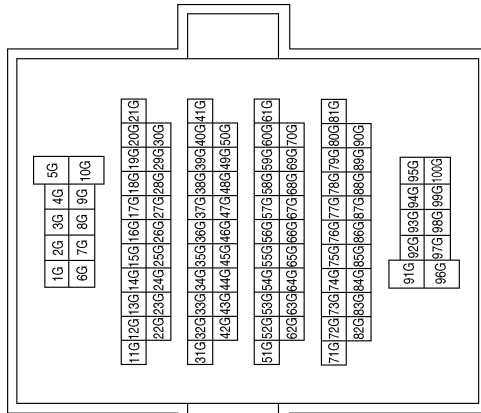

Terminal No.	Color of Wire	Signal Name
2G	Y	-
5G	L	-
10G	Y	-
11G	P	-
12G	L	-
97G	LG	-

AALIA3019GB



# FRONT WIPER AND WASHER SYSTEM

< WIRING DIAGRAM >

Connector No.	E44
Connector Name	JOINT CONNECTOR-E01
Connector Color	WHITE

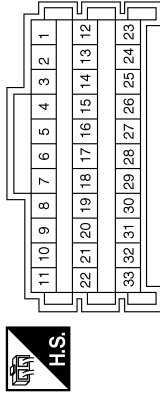

Terminal No.	Color of Wire	Signal Name
15	GR	-
16	GR	-

Connector No.	E26
Connector Name	WIRE TO WIRE
Connector Color	WHITE



Terminal No.	Color of Wire	Signal Name
14	BR	-
15	SB	-
16	V	-

Connector No.	E23
Connector Name	FRONT WIPER MOTOR
Connector Color	GRAY



Terminal No.	Color of Wire	Signal Name
1	Y	-
2	-	-
3	BR	-
4	L	-
5	GR	-

Connector No.	E71
Connector Name	JOINT CONNECTOR-E15
Connector Color	BLACK



Terminal No.	Color of Wire	Signal Name
1	L	-
2	L	-

Connector No.	E70
Connector Name	JOINT CONNECTOR-E14
Connector Color	BLACK



Terminal No.	Color of Wire	Signal Name
1	P	-
2	P	-

Connector No.	E45
Connector Name	JOINT CONNECTOR-E12
Connector Color	BLUE



Terminal No.	Color of Wire	Signal Name
1	L	-
4	L	-
7	P	-
10	P	-

AALIA3020GB

A  
B  
C  
D  
E  
F  
G  
H  
I  
J  
K  
L  
M  
N  
O  
P

WW

# FRONT WIPER AND WASHER SYSTEM

< WIRING DIAGRAM >

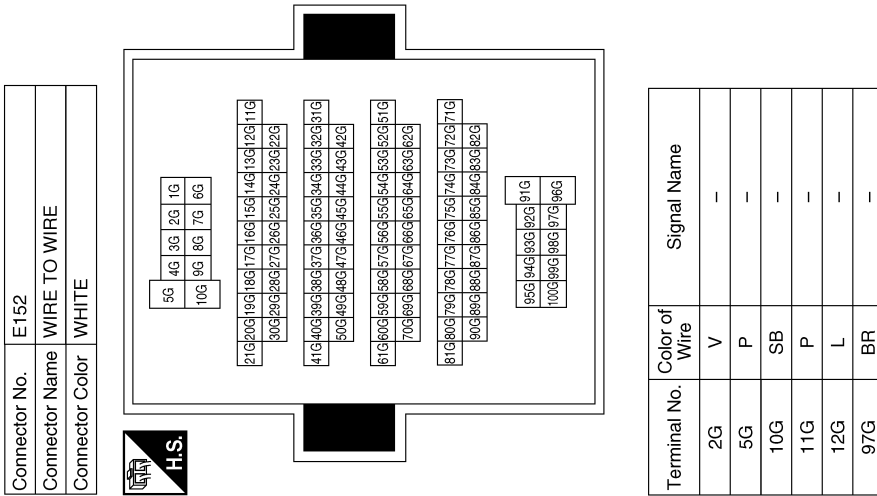

Connector No.	E121
Connector Name	IPDM E/R (INTELLIGENT POWER DISTRIBUTION MODULE ENGINE ROOM)
Connector Color	WHITE

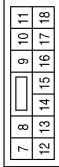

Terminal No.	Color of Wire	Signal Name
7	B	P-GND
11	Y	FR WIPER LO
18	L	FR WIPER HI

Connector No.	E119
Connector Name	IPDM E/R (INTELLIGENT POWER DISTRIBUTION MODULE ENGINE ROOM)
Connector Color	WHITE

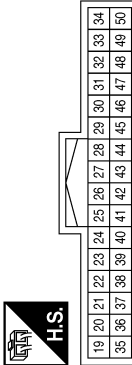

Terminal No.	Color of Wire	Signal Name
28	P	CAN-L
29	L	CAN-H
34	BR	WIPER AUTOSTOP
41	B	S-GND

AALIA3021GB

# FRONT WIPER AND WASHER SYSTEM

< WIRING DIAGRAM >

Connector No.	E224
Connector Name	FRONT AND REAR WASHER MOTOR
Connector Color	GRAY



Terminal No.	Color of Wire	Signal Name
1	B	-
2	L	-

Connector No.	E217
Connector Name	IPDM E/R (INTELLIGENT POWER DISTRIBUTION MODULE ENGINE ROOM)
Connector Color	WHITE

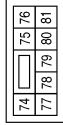

Terminal No.	Color of Wire	Signal Name
74	W	WASH MTR

Connector No.	E209
Connector Name	WIRE TO WIRE
Connector Color	WHITE

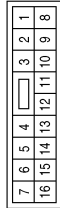

Terminal No.	Color of Wire	Signal Name
14	L	-
15	W	-
16	B	-

Connector No.	B101
Connector Name	WIRE TO WIRE
Connector Color	WHITE

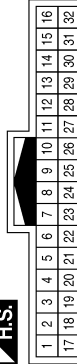

Terminal No.	Color of Wire	Signal Name
21	P	-
22	L	-
28	P	-
29	L	-

AALIA3022GB

A  
B  
C  
D  
E  
F  
G  
H  
I  
J  
K  
L  
M  
N  
O  
P

WW

# REAR WIPER AND WASHER SYSTEM

< WIRING DIAGRAM >

## REAR WIPER AND WASHER SYSTEM

Wiring Diagram

INFOID:000000011218061

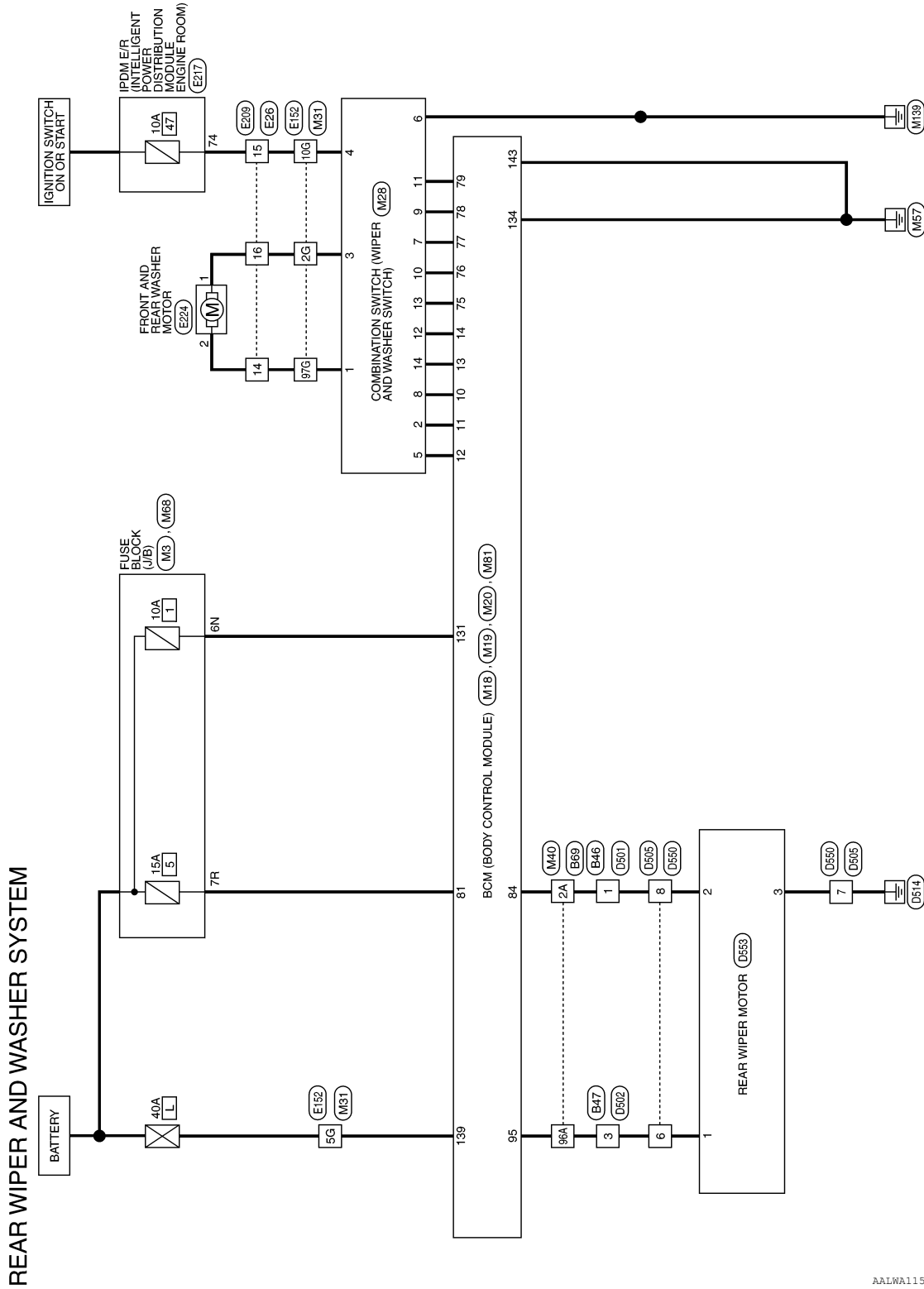

AALWA1155GB

# REAR WIPER AND WASHER SYSTEM

< WIRING DIAGRAM >

## REAR WIPER AND WASHER SYSTEM CONNECTORS

Connector No.	M3
Connector Name	FUSE BLOCK (J/B)
Connector Color	WHITE

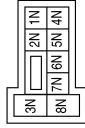

Terminal No.	Color of Wire	Signal Name
6N	W	-

Connector No.	M18
Connector Name	BCM (BODY CONTROL MODULE)
Connector Color	GREEN

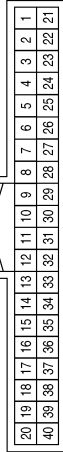

Terminal No.	Color of Wire	Signal Name
10	W	COMBI SW OUT 5
11	BG	COMBI SW OUT 4
12	R	COMBI SW OUT 3
13	G	COMBI SW OUT 2
14	P	COMBI SW OUT 1

Connector No.	M19
Connector Name	BCM (BODY CONTROL MODULE)
Connector Color	BLACK

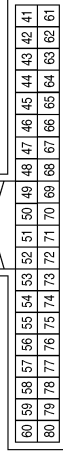

Terminal No.	Color of Wire	Signal Name
75	BG	COMBI SW IN 5
76	P	COMBI SW IN 4
77	R	COMBI SW IN 3
78	G	COMBI SW IN 2
79	W	COMBI SW IN 1

Connector No.	M20
Connector Name	BCM (BODY CONTROL MODULE)
Connector Color	GRAY

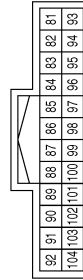

Terminal No.	Color of Wire	Signal Name
81	L	BAT REAR WIPER FUSE
84	BR	R WIPER AUTOSTOP SW
95	V	REAR WIPER OUT

Connector No.	M28
Connector Name	COMBINATION SWITCH (WIPER AND WASHER SWITCH)
Connector Color	WHITE

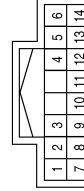

Terminal No.	Color of Wire	Signal Name
1	LG	-
2	BG	-
3	Y	-
4	Y	-

Terminal No.	Color of Wire	Signal Name
5	R	-
6	GR	-
7	R	-
8	W	-
9	G	-
10	P	-
11	W	-
12	P	-
13	BG	-
14	G	-

A B C D E F G H I J K M N O P

WW

# REAR WIPER AND WASHER SYSTEM

< WIRING DIAGRAM >

Connector No.	M68
Connector Name	FUSE BLOCK (J/B)
Connector Color	BROWN



Terminal No.	Color of Wire	Signal Name
7R	L	-

Connector No.	M40
Connector Name	WIRE TO WIRE
Connector Color	GRAY

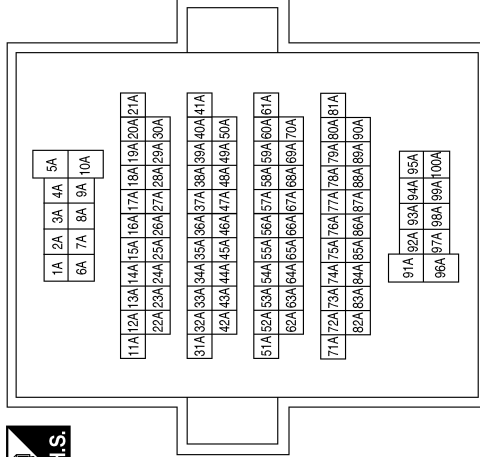

Terminal No.	Color of Wire	Signal Name
2A	BR	-
96A	V	-

Connector No.	M31
Connector Name	WIRE TO WIRE
Connector Color	WHITE

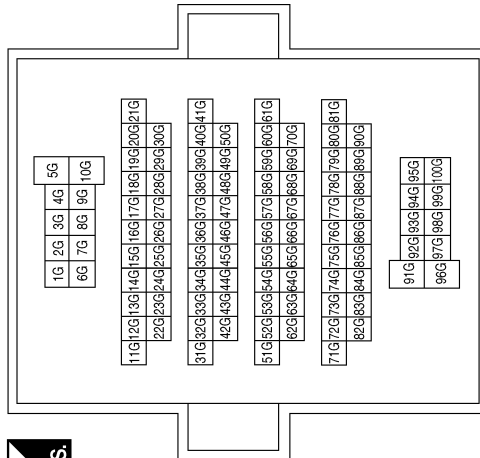

Terminal No.	Color of Wire	Signal Name
2G	Y	-
5G	L	-
10G	Y	-
97G	LG	-

AALIA2997GB

# REAR WIPER AND WASHER SYSTEM

< WIRING DIAGRAM >

Connector No.	M81
Connector Name	BCM (BODY CONTROL MODULE)
Connector Color	WHITE

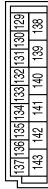

Terminal No.	Color of Wire	Signal Name
131	W	BAT BCM FUSE
134	GR	GND 2
139	L	BAT POWER F/L
143	GR	GND 1

Connector No.	E26
Connector Name	WIRE TO WIRE
Connector Color	WHITE

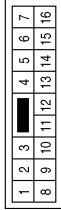

Terminal No.	Color of Wire	Signal Name
14	BR	-
15	SB	-
16	V	-

Connector No.	E152
Connector Name	WIRE TO WIRE
Connector Color	WHITE

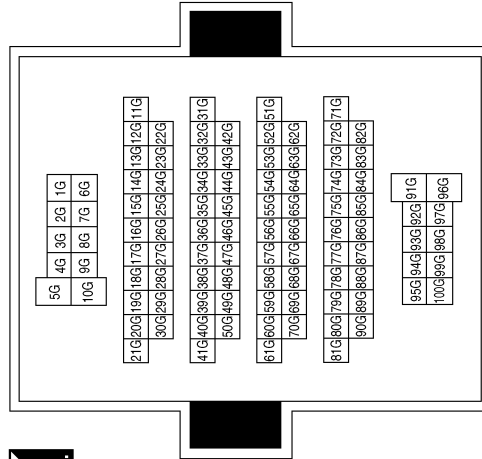

Terminal No.	Color of Wire	Signal Name
2G	V	-
5G	P	-
10G	SB	-
97G	BR	-

Connector No.	E209
Connector Name	WIRE TO WIRE
Connector Color	WHITE



Terminal No.	Color of Wire	Signal Name
14	L	-
15	W	-
16	B	-

AALIA2998GB

A  
B  
C  
D  
E  
F  
G  
H  
I  
J  
K  
L  
M  
N  
O  
P

WW

# REAR WIPER AND WASHER SYSTEM

< WIRING DIAGRAM >

Connector No.	E217
Connector Name	IPDM E/R (INTELLIGENT POWER DISTRIBUTION MODULE ENGINE ROOM)
Connector Color	WHITE

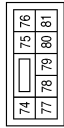

Terminal No.	Color of Wire	Signal Name
74	W	WASH MTR

Connector No.	E224
Connector Name	FRONT AND REAR WASHER MOTOR
Connector Color	GRAY



Terminal No.	Color of Wire	Signal Name
1	B	-
2	L	-

Connector No.	B46
Connector Name	WIRE TO WIRE
Connector Color	WHITE

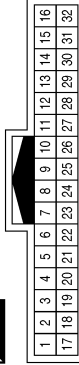

Terminal No.	Color of Wire	Signal Name
1	O	-

Connector No.	B47
Connector Name	WIRE TO WIRE
Connector Color	GRAY



Terminal No.	Color of Wire	Signal Name
3	V/O	-

Connector No.	B69
Connector Name	WIRE TO WIRE
Connector Color	GRAY

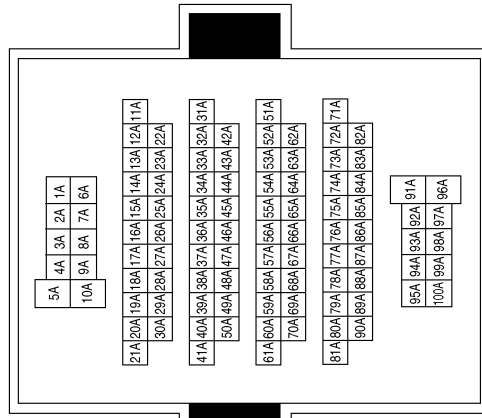

Terminal No.	Color of Wire	Signal Name
2A	O	-
96A	V/O	-



# REAR WIPER AND WASHER SYSTEM

< WIRING DIAGRAM >

Connector No.	D501
Connector Name	WIRE TO WIRE
Connector Color	WHITE

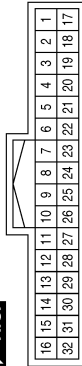

Terminal No.	Color of Wire	Signal Name
1	W/O	-

Connector No.	D502
Connector Name	WIRE TO WIRE
Connector Color	GRAY

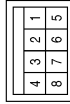

Terminal No.	Color of Wire	Signal Name
3	W	-

Connector No.	D505
Connector Name	WIRE TO WIRE
Connector Color	GRAY

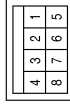

Terminal No.	Color of Wire	Signal Name
6	W	-
7	B	-
8	W/O	-

Connector No.	D550
Connector Name	WIRE TO WIRE
Connector Color	GRAY

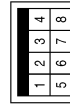

Terminal No.	Color of Wire	Signal Name
6	W	-
7	B	-
8	W/O	-

Connector No.	D553
Connector Name	REAR WIPER MOTOR
Connector Color	WHITE



Terminal No.	Color of Wire	Signal Name
1	W	-
2	W/O	-
3	B	-

AALIA3000GB

A B C D E F G H I J K L M N O P

WW

# DIAGNOSIS AND REPAIR WORKFLOW

< BASIC INSPECTION >

## BASIC INSPECTION

### DIAGNOSIS AND REPAIR WORKFLOW

Work Flow

INFOID:000000011492092

#### OVERALL SEQUENCE

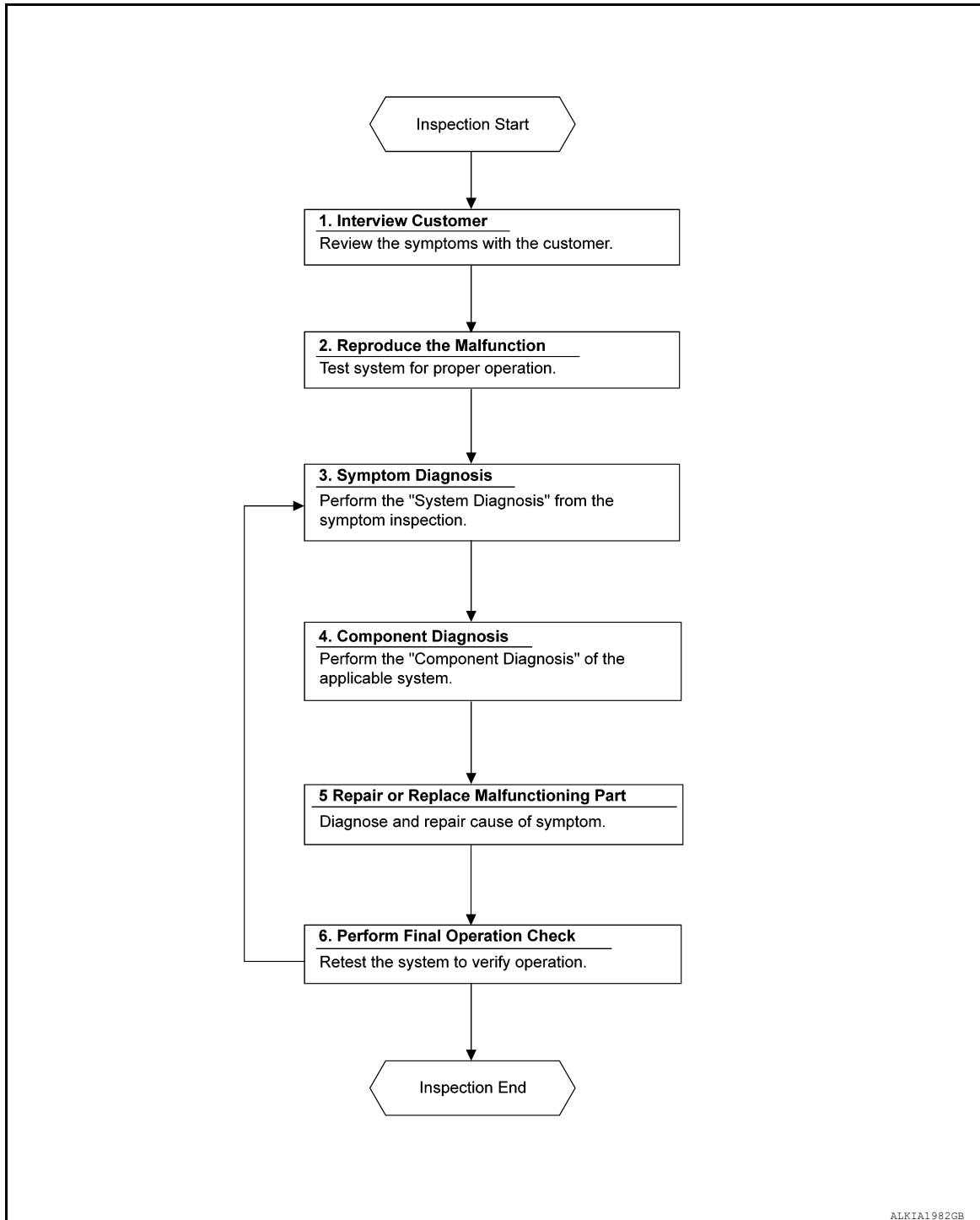

#### DETAILED FLOW

##### 1. INTERVIEW CUSTOMER

Interview the customer to obtain as much information as possible about the conditions and environment under which the malfunction occurred.

# DIAGNOSIS AND REPAIR WORKFLOW

< BASIC INSPECTION >

---

>> GO TO 2.

## 2. REPRODUCE THE MALFUNCTION

---

Reproduce the malfunction on the vehicle that the customer describes.  
Inspect the relation of the symptoms and the condition when the symptoms occur.

>> GO TO 3.

## 3. SYMPTOM DIAGNOSIS

---

Use Symptom diagnosis from the symptom inspection result in step 2 and then identify where to start performing the diagnosis based on possible causes and symptoms.

>> GO TO 4.

## 4. COMPONENT DIAGNOSIS

---

Perform the diagnosis with Component diagnosis of the applicable system.

>> GO TO 5.

## 5. REPAIR OR REPLACE THE MALFUNCTIONING PART

---

Repair or replace the specified malfunctioning parts.

>> GO TO 6.

## 6. PERFORM FINAL OPERATIONAL CHECK

---

Check that malfunctions are not reproduced when obtaining the malfunction information from the customer, referring to the symptom inspection result in step 2.

Are the malfunctions corrected?

YES >> Inspection End.

NO >> GO TO 3.

A  
B  
C  
D  
E  
F  
G  
H  
I  
J  
K  
M  
N  
O  
P

WW

## WIPER AND WASHER FUSE

< DTC/CIRCUIT DIAGNOSIS >

### DTC/CIRCUIT DIAGNOSIS

#### WIPER AND WASHER FUSE

##### Diagnosis Procedure

INFOID:0000000011218064

#### 1. CHECK FUSES

Check that the following fuses are not blown:

Component	Capacity	Fuse No.	Location
Front wiper motor	30A	48	IPDM E/R
Front and rear washer motor	10A	47	IPDM E/R

##### Is the fuse blown?

- YES >> Replace the blown fuse after repairing the affected circuit.  
NO >> Inspection End.

# FRONT WIPER MOTOR LO CIRCUIT

< DTC/CIRCUIT DIAGNOSIS >

## FRONT WIPER MOTOR LO CIRCUIT

### Component Function Check

INFOID:0000000011218065

#### 1. CHECK FRONT WIPER LO OPERATION

##### CONSULT

1. Select "FRONT WIPER" in "Active Test" mode of "IPDM E/R".
2. While operating the test item, check front wiper operation.

**Lo** : Front wiper (LO) operation

**Off** : Stop the front wiper.

Is front wiper (LO) operation normal?

- YES >> Front wiper motor LO circuit is normal.  
NO >> Refer to [WW-37, "Diagnosis Procedure"](#).

### Diagnosis Procedure

INFOID:0000000011218066

Regarding Wiring Diagram information, refer to [WW-22, "Wiring Diagram"](#).

#### 1. CHECK FRONT WIPER MOTOR (LO) OUTPUT VOLTAGE

##### CONSULT

1. Turn ignition switch OFF.
2. Disconnect front wiper motor connector.
3. Turn ignition switch ON.
4. Select "FRONT WIPER" in "Active Test" mode of "IPDM E/R".
5. While operating the test item, check voltage between front wiper motor harness connector and ground.

(+)		(-)	Condition		Voltage (Approx.)
Front wiper motor					
Connector	Terminal				
E23	1	Ground	FRONT WIPER	Lo	Battery voltage
				Off	0 V

Is the inspection result normal?

- YES >> Replace front wiper motor. Refer to [WW-68, "Removal and Installation"](#).  
NO >> GO TO 2.

#### 2. CHECK FRONT WIPER MOTOR (LO) CIRCUIT

1. Turn ignition switch OFF.
2. Disconnect IPDM E/R connector.
3. Check continuity between IPDM E/R harness connector and front wiper motor harness connector.

IPDM E/R		Front wiper motor		Continuity
Connector	Terminal	Connector	Terminal	
E121	11	E23	1	Yes

4. Check continuity between IPDM E/R harness connector and ground.

IPDM E/R		Ground	Continuity
Connector	Terminal		
E121	11		No

Is the inspection result normal?

- YES >> Replace IPDM E/R. Refer to [PCS-37, "Removal and Installation"](#).

A  
B  
C  
D  
E  
F  
G  
H  
I  
J  
K  
M  
N  
O  
P

WW

## FRONT WIPER MOTOR LO CIRCUIT

< DTC/CIRCUIT DIAGNOSIS >

---

NO >> Repair or replace harness.

# FRONT WIPER MOTOR HI CIRCUIT

< DTC/CIRCUIT DIAGNOSIS >

## FRONT WIPER MOTOR HI CIRCUIT

### Component Function Check

INFOID:000000011218067

#### 1. CHECK FRONT WIPER HI OPERATION

##### CONSULT

1. Select "FRONT WIPER" in "Active Test" mode of "IPDM E/R".
2. While operating the test item, check the front wiper operation.

**Hi** : Front wiper (HI) operation

**Off** : Stop the front wiper.

Is the inspection result normal?

- YES >> Front wiper motor HI circuit is normal.  
NO >> Refer to [WW-39, "Diagnosis Procedure"](#).

### Diagnosis Procedure

INFOID:000000011218068

Regarding Wiring Diagram information, refer to [WW-22, "Wiring Diagram"](#).

#### 1. CHECK FRONT WIPER MOTOR (HI) OUTPUT VOLTAGE

##### CONSULT

1. Turn ignition switch OFF.
2. Disconnect front wiper motor connector.
3. Turn ignition switch ON.
4. Select "FRONT WIPER" in "Active Test" mode of "IPDM E/R".
5. While operating the test item, check voltage between front wiper motor harness connector and ground.

(+)		(-)	Condition		Voltage (Approx.)
Front wiper motor					
Connector	Terminal				
E23	4	Ground	FRONT WIPER	Hi	Battery voltage
				Off	0 V

Is the inspection result normal?

- YES >> Replace front wiper motor. Refer to [WW-68, "Removal and Installation"](#).  
NO >> GO TO 2.

#### 2. CHECK FRONT WIPER MOTOR (HI) CIRCUIT

1. Turn ignition switch OFF.
2. Disconnect IPDM E/R connector.
3. Check continuity between IPDM E/R harness connector and front wiper motor harness connector.

IPDM E/R		Front wiper motor		Continuity
Connector	Terminal	Connector	Terminal	
E121	18	E23	4	Yes

4. Check continuity between IPDM E/R harness connector and ground.

IPDM E/R		Ground	Continuity
Connector	Terminal		
E121	18		No

Is the inspection result normal?

- YES >> Replace IPDM E/R. Refer [PCS-37, "Removal and Installation"](#).

A  
B  
C  
D  
E  
F  
G  
H  
I  
J  
K  
M  
N  
O  
P

WW

## FRONT WIPER MOTOR HI CIRCUIT

< DTC/CIRCUIT DIAGNOSIS >

---

NO >> Repair or replace harness.



# FRONT WIPER STOP POSITION SIGNAL CIRCUIT

< DTC/CIRCUIT DIAGNOSIS >

## FRONT WIPER STOP POSITION SIGNAL CIRCUIT

### Component Function Check

INFOID:0000000011218069

#### 1. CHECK FRONT WIPER STOP POSITION SIGNAL

##### CONSULT

1. Select "WIP AUTO STOP" in "Data Monitor" mode of "IPDM E/R".
2. Operate the front wiper.
3. Check that the function operates normally according to the following conditions:

Monitor item	Condition		Monitor status
WIP AUTO STOP	Front wiper motor	Stop position	STOP P
		Except stop position	ACT P

Is the inspection result normal?

- YES >> Front wiper stop position signal circuit is normal.  
NO >> Refer to [WW-41, "Diagnosis Procedure"](#).

### Diagnosis Procedure

INFOID:0000000011218070

Regarding Wiring Diagram information, refer to [WW-22, "Wiring Diagram"](#).

#### 1. CHECK IPDM E/R OUTPUT VOLTAGE

1. Turn ignition switch OFF.
2. Disconnect front wiper motor connector.
3. Turn ignition switch ON.
4. Check voltage between front wiper motor harness connector and ground.

(+)		(-)	Voltage (Approx.)
Front wiper motor			
Connector	Terminal	Ground	Battery voltage
E23	3		

Is the inspection result normal?

- YES >> Replace front wiper motor. Refer to [WW-68, "Removal and Installation"](#).  
NO >> GO TO 2.

#### 2. CHECK FRONT WIPER STOP POSITION SIGNAL CIRCUIT

1. Turn ignition switch OFF.
2. Disconnect IPDM E/R connector.
3. Check continuity between IPDM E/R harness connector and front wiper motor harness connector.

IPDM E/R		Front wiper motor		Continuity
Connector	Terminal	Connector	Terminal	
E119	34	E23	3	Yes

4. Check continuity between IPDM E/R harness connector and ground.

IPDM E/R		Ground	Continuity
Connector	Terminal		
E119	34		No

Is the inspection result normal?

- YES >> Replace IPDM E/R. Refer to [PCS-37, "Removal and Installation"](#).  
NO >> Repair or replace harness.

A  
B  
C  
D  
E  
F  
G  
H  
I  
J  
K  
M  
N  
O  
P

WW

# FRONT WIPER MOTOR GROUND CIRCUIT

< DTC/CIRCUIT DIAGNOSIS >

## FRONT WIPER MOTOR GROUND CIRCUIT

### Diagnosis Procedure

INFOID:000000011218071

Regarding Wiring Diagram information, refer to [WW-22. "Wiring Diagram"](#).

### 1. CHECK FRONT WIPER MOTOR GROUND CIRCUIT

1. Turn ignition switch OFF.
2. Disconnect front wiper motor connector.
3. Check continuity between front wiper motor harness connector and ground.

Front wiper motor		Ground	Continuity
Connector	Terminal		Yes
E23	3		Yes

Is the inspection result normal?

- YES >> Inspection End.  
NO >> Repair or replace harness.

# WASHER MOTOR CIRCUIT

< DTC/CIRCUIT DIAGNOSIS >

## WASHER MOTOR CIRCUIT

### Diagnosis Procedure

INFOID:000000011218072

Regarding Wiring Diagram information, refer to [WW-22. "Wiring Diagram"](#).

### 1. CHECK FRONT AND REAR WASHER MOTOR FUSE

1. Turn ignition switch OFF.
2. Check that the following fuse is not blown:

Component	Capacity	Fuse No.	Location
Front and rear washer motor	10A	47	IPDM E/R

Is the fuse blown?

- YES >> Replace the blown fuse after repairing the affected circuit.  
NO >> GO TO 2.

### 2. CHECK FRONT AND REAR WASHER MOTOR POWER SUPPLY

1. Disconnect the front and rear washer motor.
2. Turn ignition switch ON.
3. Check voltage between front and rear washer motor harness connector and ground.

Terminals		Washer switch	Voltage (Approx.)
(+)	(-)		
Front and rear washer motor		ON	Battery voltage
Connector	Terminal		
E224	1		
		OFF	0 V

Front washer operation

Terminals		Washer switch	Voltage (Approx.)
(+)	(-)		
Front and rear washer motor		ON	Battery voltage
Connector	Terminal		
E224	2		
		OFF	0 V

Rear washer operation

Is the inspection result normal?

- YES >> Inspection End.  
NO >> GO TO 3.

### 3. CHECK WASHER SWITCH

Check washer switch. Refer to [WW-44. "Component Inspection"](#).

Is the inspection result normal?

- YES >> Repair harness between fuse and the front and rear washer motor.  
NO >> Replace washer switch. Refer to [WW-70. "Removal and Installation"](#).

# WASHER SWITCH

< DTC/CIRCUIT DIAGNOSIS >

## WASHER SWITCH

### Description

INFOID:000000011218075

- Washer switch is integrated with the combination switch.
- Combination switch (wiper and washer switch) switches polarity between front and rear washer operation to supply power and ground to the front and rear washer motor.

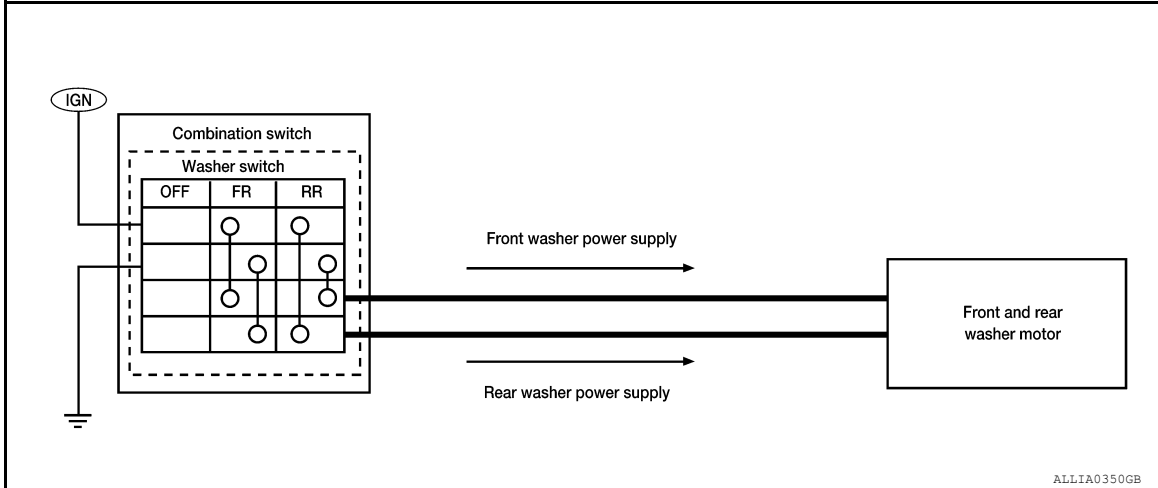

### Component Inspection

INFOID:000000011218076

#### 1. CHECK FRONT WASHER SWITCH

1. Turn ignition switch OFF.
2. Disconnect combination switch (wiper and washer switch).
3. Check continuity between the combination switch (wiper and washer switch) terminals.

A: Terminal 4

B: Terminal 6

C: Terminal 3

D: Terminal 1

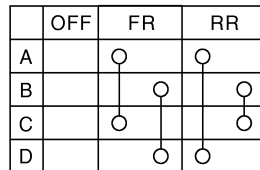

JPLIA0164GB

Combination switch (wiper and washer switch)		Condition	Continuity
Terminal			
1	6	Front washer switch ON	Yes
3	4		

Is the inspection result normal?

YES >> GO TO 2.

NO >> Replace combination switch (wiper and washer switch). Refer to [WW-70, "Removal and Installation"](#).

#### 2. CHECK REAR WASHER SWITCH

1. Check continuity between the combination switch (wiper and washer switch) terminals.

# WASHER SWITCH

## < DTC/CIRCUIT DIAGNOSIS >

- A: Terminal 4
- B: Terminal 6
- C: Terminal 3
- D: Terminal 1

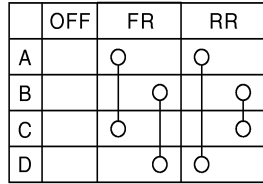

JPLIA0164GB

Combination switch (wiper and washer switch)		Condition	Continuity
Terminal			
1	4	Rear washer switch ON	Yes
6	3		

### Is the inspection result normal?

- YES >> Wiper and washer switch is normal.
- NO >> Replace combination switch (wiper and washer switch). Refer to [WW-70, "Removal and Installation"](#).

A  
B  
C  
D  
E  
F  
G  
H  
I  
J  
K  
M  
N  
O  
P

WW

# REAR WIPER MOTOR CIRCUIT

< DTC/CIRCUIT DIAGNOSIS >

## REAR WIPER MOTOR CIRCUIT

### Component Function Check

INFOID:000000011218077

#### 1. CHECK REAR WIPER ON OPERATION

##### CONSULT

1. Select "RR WIPER" in "Active Test" mode of "BCM".
2. While operating the test item, check rear wiper operation.

**On** : Rear wiper ON operation

**Off** : Stop the rear wiper.

Is the inspection result normal?

- YES >> Rear wiper motor circuit is normal.  
NO >> Refer to [WW-46, "Diagnosis Procedure"](#).

#### Diagnosis Procedure

INFOID:000000011218078

Regarding Wiring Diagram information, refer to [WW-28, "Wiring Diagram"](#).

#### 1. CHECK REAR WIPER MOTOR OUTPUT VOLTAGE

##### CONSULT

1. Turn ignition switch OFF.
2. Disconnect rear wiper motor connector.
3. Turn ignition switch ON.
4. Select "RR WIPER" in "Active Test" mode of "BCM".
5. While operating the test item, check voltage between rear wiper motor harness connector and ground.

(+)		(-)	Condition		Voltage (Approx.)
Rear wiper motor					
Connector	Terminal				
D553	1	Ground	REAR WIPER	On	Battery voltage
				Off	0 V

Is the inspection result normal?

- YES >> GO TO 3.  
NO >> GO TO 2.

#### 2. CHECK REAR WIPER MOTOR CIRCUIT

1. Turn ignition switch OFF.
2. Disconnect BCM connector.
3. Check continuity between BCM harness connector and rear wiper motor harness connector.

BCM		Rear wiper motor		Continuity
Connector	Terminal	Connector	Terminal	
M20	95	D553	1	Yes

4. Check continuity between BCM harness connector and ground.

BCM		Ground	Continuity
Connector	Terminal		
M20	95		No

Is the inspection result normal?

- YES >> Replace BCM. Refer to [BCS-82, "Removal and Installation"](#).

# REAR WIPER MOTOR CIRCUIT

## < DTC/CIRCUIT DIAGNOSIS >

NO >> Repair or replace harness.

### 3. CHECK REAR WIPER MOTOR GROUND OPEN CIRCUIT

1. Turn ignition switch OFF.
2. Check continuity between rear wiper motor harness connector and ground.

Rear wiper motor		Ground	Continuity
Connector	Terminal		Yes
D553	3		

#### Is the inspection result normal?

- YES >> Replace rear wiper motor. Refer to [WW-73. "Removal and Installation"](#).  
NO >> Repair or replace harness.

A  
B  
C  
D  
E  
F  
G  
H  
I  
J  
K  
M  
N  
O  
P

WW

# REAR WIPER STOP POSITION SIGNAL CIRCUIT

< DTC/CIRCUIT DIAGNOSIS >

## REAR WIPER STOP POSITION SIGNAL CIRCUIT

### Component Function Check

INFOID:000000011218079

#### 1. CHECK REAR WIPER STOP POSITION SIGNAL

##### CONSULT

1. Select "RR WIPER STOP" in "Data Monitor" mode of "BCM".
2. Operate the rear wiper.
3. Check that the function operates normally according to the following conditions:

Monitor item	Condition		Monitor status
RR WIPER STOP	Rear wiper motor	Stop position	On
		Except stop position	Off

Is the inspection result normal?

- YES >> Rear wiper stop position signal circuit is normal.  
NO >> Refer to [WW-48, "Diagnosis Procedure"](#).

### Diagnosis Procedure

INFOID:000000011218080

Regarding Wiring Diagram information, refer to [WW-28, "Wiring Diagram"](#).

#### 1. CHECK BCM OUTPUT VOLTAGE

1. Turn ignition switch OFF.
2. Disconnect rear wiper motor connector.
3. Turn ignition switch ON.
4. Check voltage between rear wiper motor harness connector and ground.

(+)		(-)	Voltage (Approx.)
Rear wiper motor			
Connector	Terminal	Ground	Battery voltage
D553	2		

Is the inspection result normal?

- YES >> Replace rear wiper motor.  
NO >> GO TO 2.

#### 2. CHECK REAR WIPER STOP POSITION SIGNAL CIRCUIT

1. Turn ignition switch OFF.
2. Disconnect BCM connector.
3. Check continuity between BCM harness connector and rear wiper motor harness connector.

BCM		Rear wiper motor		Continuity
Connector	Terminal	Connector	Terminal	
M20	84	D553	2	Yes

4. Check continuity between BCM harness connector and ground.

BCM		Ground	Continuity
Connector	Terminal		
M20	84		No

Is the inspection result normal?

- YES >> Replace BCM. Refer to [BCS-82, "Removal and Installation"](#).  
NO >> Repair or replace harness.



# WIPER AND WASHER SYSTEM SYMPTOMS

< SYMPTOM DIAGNOSIS >

## SYMPTOM DIAGNOSIS

### WIPER AND WASHER SYSTEM SYMPTOMS

#### Symptom Table

INFOID:000000011218081

**CAUTION:**

Perform the “Self Diagnostic Result” with Consult before performing the diagnosis by symptom. Perform the diagnosis by DTC if DTC is detected.

Symptom		Probable malfunction location	Inspection item
Front wiper does not operate in . . .	HI only	<ul style="list-style-type: none"> <li>• Combination switch (wiper and washer switch)</li> <li>• Harness between combination switch and BCM</li> <li>• BCM</li> </ul>	Combination switch (wiper and washer switch) Refer to <a href="#">BCS-80, "Symptom Table"</a>
		<ul style="list-style-type: none"> <li>• IPDM E/R</li> <li>• Harness between IPDM E/R and front wiper motor</li> <li>• Front wiper motor</li> </ul>	Front wiper motor (HI) circuit Refer to <a href="#">WW-39, "Component Function Check"</a>
		Front wiper request signal <ul style="list-style-type: none"> <li>• BCM</li> <li>• IPDM E/R</li> </ul>	BCM "Data Monitor" "FR WIPER HI" Refer to <a href="#">BCS-20, "WIPER : CONSULT Function (BCM - WIPER)"</a> .
	LO only	<ul style="list-style-type: none"> <li>• Combination switch</li> <li>• Harness between combination switch and BCM</li> <li>• BCM</li> </ul>	Combination switch (wiper and washer switch) Refer to <a href="#">BCS-80, "Symptom Table"</a>
		<ul style="list-style-type: none"> <li>• IPDM E/R</li> <li>• Harness between IPDM E/R and front wiper motor</li> <li>• Front wiper motor</li> </ul>	Front wiper motor (LO) circuit Refer to <a href="#">WW-37, "Component Function Check"</a>
		Front wiper request signal <ul style="list-style-type: none"> <li>• BCM</li> <li>• IPDM E/R</li> </ul>	BCM "Data Monitor" "FR WIPER LOW" Refer to <a href="#">BCS-20, "WIPER : CONSULT Function (BCM - WIPER)"</a> .
	AUTO only	<ul style="list-style-type: none"> <li>• Combination switch</li> <li>• Harness between combination switch and BCM</li> <li>• BCM</li> </ul>	Combination switch (wiper and washer switch) Refer to <a href="#">BCS-80, "Symptom Table"</a>
	HI, LO and AUTO	SYMPTOM DIAGNOSIS "FRONT WIPER DOES NOT OPERATE" Refer to <a href="#">WW-53, "Diagnosis Procedure"</a>	

A  
B  
C  
D  
E  
F  
G  
H  
I  
J  
K  
M  
N  
O  
P

WW

# WIPER AND WASHER SYSTEM SYMPTOMS

## < SYMPTOM DIAGNOSIS >

Symptom	Probable malfunction location	Inspection item		
Front wiper does not stop in . . .	HI only	<ul style="list-style-type: none"> <li>• Combination switch</li> <li>• BCM</li> </ul>	Combination switch (wiper and washer switch) Refer to <a href="#">BCS-80, "Symptom Table"</a>	
		Front wiper request signal <ul style="list-style-type: none"> <li>• BCM</li> <li>• IPDM E/R</li> </ul>	BCM "Data Monitor" "FR WIPER HI" Refer to <a href="#">BCS-20, "WIPER : CONSULT Function (BCM - WIPER)"</a> .	
		IPDM E/R	—	
	LO only	<ul style="list-style-type: none"> <li>• Combination switch</li> <li>• BCM</li> </ul>	Combination switch (wiper and washer switch) Refer to <a href="#">BCS-80, "Symptom Table"</a>	
		Front wiper request signal <ul style="list-style-type: none"> <li>• BCM</li> <li>• IPDM E/R</li> </ul>	BCM "Data Monitor" "FR WIPER LOW" Refer to <a href="#">BCS-20, "WIPER : CONSULT Function (BCM - WIPER)"</a> .	
		IPDM E/R	—	
	AUTO only	<ul style="list-style-type: none"> <li>• Combination switch</li> <li>• BCM</li> </ul>	Combination switch (wiper and washer switch) Refer to <a href="#">BCS-80, "Symptom Table"</a>	
	Front wiper does not operate normally in . . .	Sensitivity adjustment cannot be performed.	<ul style="list-style-type: none"> <li>• Combination switch</li> <li>• Harness between combination switch and BCM</li> <li>• BCM</li> </ul>	Combination switch (wiper and washer switch) Refer to <a href="#">BCS-80, "Symptom Table"</a>
			BCM	—
Auto wiping operation does not operate		Check that the wiper setting is auto wiping operation Refer to <a href="#">BCS-20, "WIPER : CONSULT Function (BCM - WIPER)"</a>		
Wiper is not linked to the washer operation.		<ul style="list-style-type: none"> <li>• Combination switch</li> <li>• Harness between combination switch and BCM</li> <li>• BCM</li> </ul>	Combination switch (wiper and washer switch) Refer to <a href="#">BCS-80, "Symptom Table"</a>	
		BCM	—	
Does not return to stop position. [Repeatedly operates for 10 seconds and then stops for 20 seconds. (Fail-safe)]	<ul style="list-style-type: none"> <li>• IPDM E/R</li> <li>• Harness between IPDM E/R and front wiper motor</li> <li>• Front wiper motor</li> </ul>	Front wiper stop position signal circuit Refer to <a href="#">WW-41, "Component Function Check"</a>		
Rear wiper does not operate in . . .	ON only	<ul style="list-style-type: none"> <li>• Combination switch</li> <li>• Harness between combination switch and BCM</li> <li>• BCM</li> </ul>	Combination switch (wiper and washer switch) Refer to <a href="#">BCS-80, "Symptom Table"</a>	
	INT only	<ul style="list-style-type: none"> <li>• Combination switch</li> <li>• Harness between combination switch and BCM</li> <li>• BCM</li> </ul>	Combination switch (wiper and washer switch) Refer to <a href="#">BCS-80, "Symptom Table"</a>	
	ON and INT	<ul style="list-style-type: none"> <li>• Combination switch</li> <li>• Harness between combination switch and BCM</li> <li>• BCM</li> </ul>	Combination switch (wiper and washer switch) Refer to <a href="#">BCS-80, "Symptom Table"</a>	
		<ul style="list-style-type: none"> <li>• BCM</li> <li>• Harness between rear wiper motor and BCM</li> <li>• Harness between rear wiper motor and ground</li> <li>• Rear wiper motor</li> </ul>	Rear wiper motor circuit Refer to <a href="#">WW-46, "Component Function Check"</a>	

## WIPER AND WASHER SYSTEM SYMPTOMS

### < SYMPTOM DIAGNOSIS >

Symptom		Probable malfunction location	Inspection item
Rear wiper does not stop in. . .	ON only	<ul style="list-style-type: none"> <li>• Combination switch</li> <li>• BCM</li> </ul>	Combination switch (wiper and washer switch) Refer to <a href="#">BCS-80, "Symptom Table"</a>
	INT only	<ul style="list-style-type: none"> <li>• Combination switch</li> <li>• BCM</li> </ul>	Combination switch (wiper and washer switch) Refer to <a href="#">BCS-80, "Symptom Table"</a>
Rear wiper does not operate normally in. . .	Wiper is not linked to the washer operation.	<ul style="list-style-type: none"> <li>• Combination switch</li> <li>• Harness between rear wiper motor and BCM</li> <li>• BCM</li> </ul>	Combination switch (wiper and washer switch) Refer to <a href="#">BCS-80, "Symptom Table"</a>
		BCM	—
	Rear wiper does not return to the stop position. [Stops after a five-second operation. (Fail-safe)]	<ul style="list-style-type: none"> <li>• BCM</li> <li>• Harness between rear wiper motor and BCM</li> <li>• Rear wiper motor</li> </ul>	Rear wiper stop position signal circuit Refer to <a href="#">WW-48, "Component Function Check"</a>
Washer motor does not operate.	Washer motor does not operate when washing the windshield.	<ul style="list-style-type: none"> <li>• Combination switch (wiper and washer switch)</li> <li>• Harness between combination switch (wiper and washer switch) and BCM</li> <li>• BCM</li> </ul>	Combination switch (wiper and washer switch) Refer to <a href="#">BCS-80, "Symptom Table"</a>
		<ul style="list-style-type: none"> <li>• Harness between combination switch (wiper and washer switch) and washer motor</li> <li>• Washer motor</li> </ul>	Washer motor circuit Refer to <a href="#">WW-43, "Diagnosis Procedure"</a>

A  
B  
C  
D  
E  
F  
G  
H  
I  
J  
K

WW

M  
N  
O  
P

## NORMAL OPERATING CONDITION

< SYMPTOM DIAGNOSIS >

---

### NORMAL OPERATING CONDITION

#### Description

INFOID:000000011218082

#### FRONT WIPER MOTOR PROTECTION FUNCTION

- IPDM E/R may stop the front wiper to protect the front wiper motor if any obstruction (operation resistance) such as a large amount of snow is detected during the front wiper operation.
- At that time turn the front wiper OFF and remove the foreign object. Then wait for approximately 20 seconds or more and reactivate the front wiper. The wiper will operate normally.

#### REAR WIPER MOTOR PROTECTION FUNCTION

- BCM may stop the rear wiper to protect the rear wiper motor when the rear wiper is stopped for 5 seconds or more due to a snowfall.
- The rear wiper operates normally one minute after the obstacles are removed with the rear wiper OFF.

# FRONT WIPER DOES NOT OPERATE

< SYMPTOM DIAGNOSIS >

## FRONT WIPER DOES NOT OPERATE

### Description

INFOID:0000000011218083

The front wiper does not operate under any operation conditions.

### Diagnosis Procedure

INFOID:0000000011218084

#### 1. CHECK WIPER RELAY OPERATION

##### CONSULT

1. Select "FRONT WIPER" in "Active Test" mode of "IPDM E/R".
2. When operating the test item, check front wiper operation.

**Lo** : Front wiper LO operation

**Hi** : Front wiper HI operation

**Off** : Stop the front wiper.

Is front wiper operating normally?

YES >> GO TO 5.

NO >> GO TO 2.

#### 2. CHECK FRONT WIPER MOTOR FUSE

1. Turn ignition switch OFF.
2. Check that the following fuse is not blown:

Unit	Location	Fuse No.	Capacity
Front wiper motor	IPDM E/R	48	30A

Is the inspection result normal?

YES >> GO TO 3.

NO >> Replace the blown fuse after repairing the affected circuit.

#### 3. CHECK FRONT WIPER MOTOR GROUND CIRCUIT

Check front wiper motor ground circuit. Refer to [WW-42, "Diagnosis Procedure"](#).

Is the inspection result normal?

YES >> GO TO 4.

NO >> Repair or replace harness.

#### 4. CHECK FRONT WIPER MOTOR INPUT VOLTAGE

##### CONSULT

1. Turn ignition switch OFF.
2. Disconnect front wiper motor connector.
3. Turn ignition switch ON.
4. Select "FRONT WIPER" in "Active Test" mode of "IPDM E/R".
5. While operating the test item, check voltage between front wiper motor harness connector and ground.

(+)		(-)	Condition	Voltage (Approx.)
Connector	Terminal			
E23	1	Ground	Lo	Battery voltage
			Off	0 V
	4		Hi	Battery voltage
			Off	0 V

Is the inspection result normal?

YES >> Replace front wiper motor.

NO >> Replace IPDM E/R. Refer to [PCS-37, "Removal and Installation"](#).

# FRONT WIPER DOES NOT OPERATE

< SYMPTOM DIAGNOSIS >

## 5. CHECK FRONT WIPER REQUEST SIGNAL INPUT

### CONSULT

1. Select "FR WIP REQ" in "Data Monitor" mode of "IPDM E/R".
2. Switch the front wiper switch to HI and LO.
3. While operating the front wiper switch, check the status of "FR WIP REQ".

Monitor item	Condition		Monitor status
FR WIP REQ	Front wiper switch HI	On	Hi
		Off	Stop
	Front wiper switch LO	On	Low
		Off	Stop

Is the inspection result normal?

YES >> Replace IPDM E/R. Refer to [PCS-37. "Removal and Installation"](#)

NO >> GO TO 6.

## 6. CHECK COMBINATION SWITCH

Perform the inspection of the combination switch. Refer to [BCS-80. "Symptom Table"](#).

Is combination switch normal?

YES >> Replace BCM. Refer to [BCS-82. "Removal and Installation"](#).

NO >> Repair or replace the applicable parts.

# WASHER TANK

< REMOVAL AND INSTALLATION >

## REMOVAL AND INSTALLATION

### WASHER TANK

Exploded View

INFOID:0000000011218085

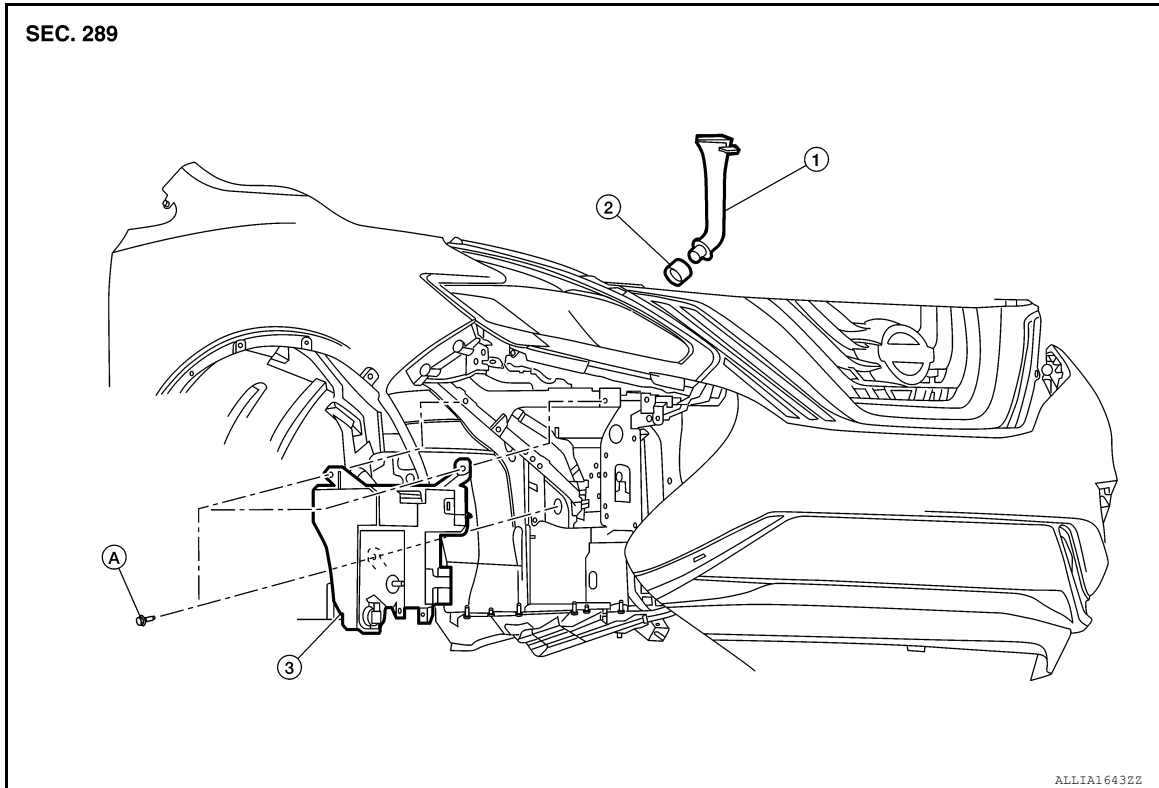

1. Washer tank inlet

2. Seal

3. Washer tank

A. Refer to INSTALLATION

### Removal and Installation

INFOID:0000000011218086

#### REMOVAL

1. Using a suitable tool, remove clip (A) from the radiator core support and remove the washer tank inlet (1) from the washer tank.

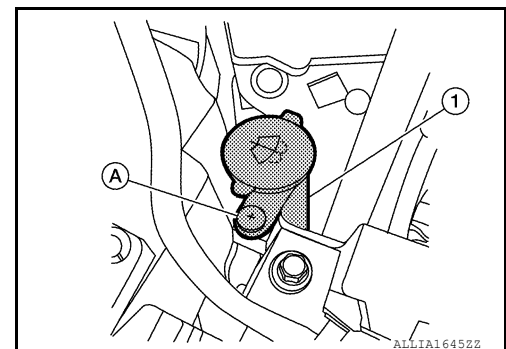

2. Remove the front fender protector (RH). Refer to [DLK-272, "Exploded View"](#).
3. Disconnect harness connector from the front and rear washer motor .
4. Disconnect harness connector from the washer fluid level switch.
5. Release the harness from the washer tank.
6. Disconnect the front and rear washer tubes from the front and rear washer motor.
7. Remove the washer tank bolts and washer tank.

A  
B  
C  
D  
E  
F  
G  
H  
I  
J  
K  
M  
N  
O  
P

WW

# WASHER TANK

## < REMOVAL AND INSTALLATION >

### INSTALLATION

Installation is in the reverse order of removal.

#### CAUTION:

- Add water up to the top of washer tank inlet after installing. Check that no leaks exist.
- Fill washer tank with specified amount of fluid. Refer to [WW-77. "Specifications"](#).
- Tighten the washer tank bolts to specification in the sequence shown.

⇐: Front

Washer tank bolts : 4.5 N·m (0.46 kg-m, 40 in-lb)

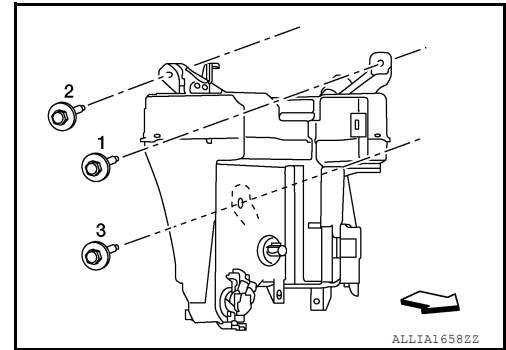



# FRONT AND REAR WASHER MOTOR

< REMOVAL AND INSTALLATION >

## FRONT AND REAR WASHER MOTOR

Exploded View

INFOID:000000011781767

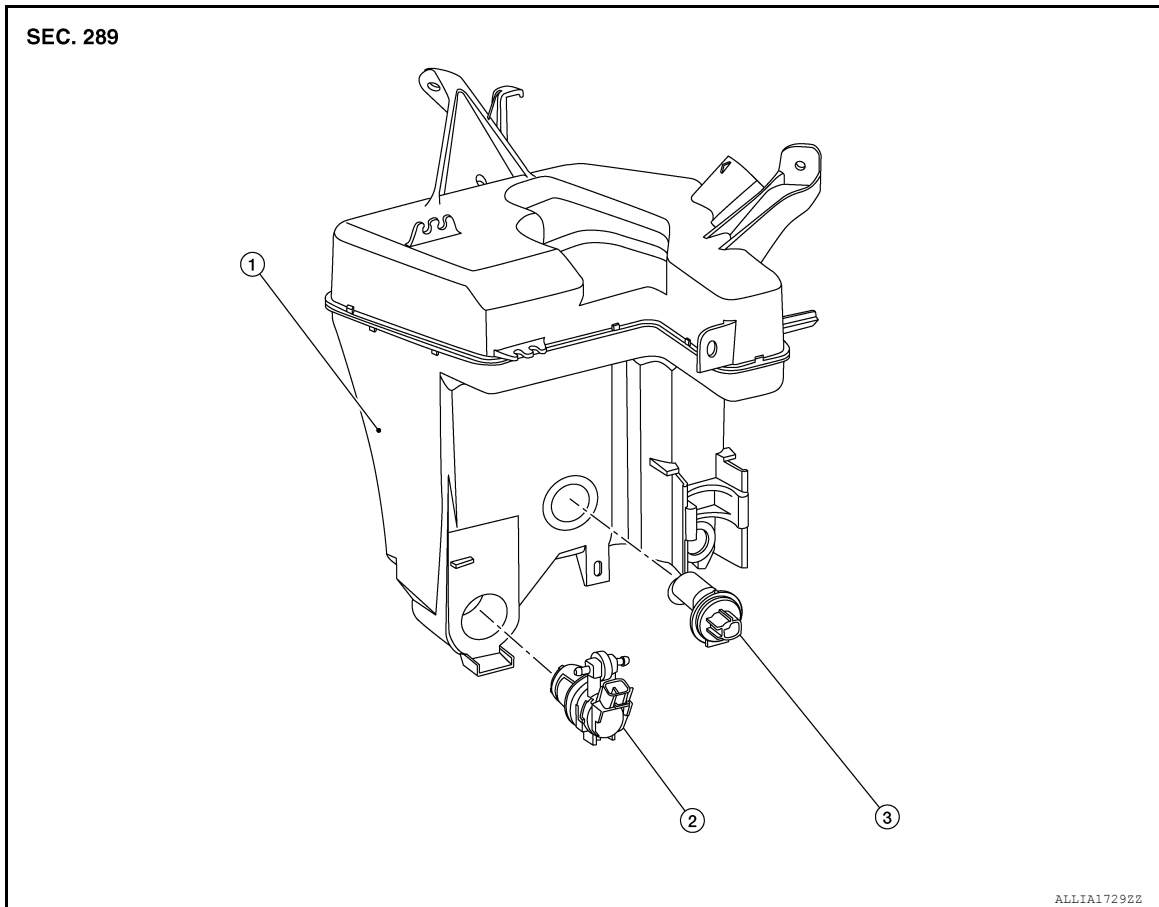

1. Washer tank    2. Front and rear washer motor    3. Washer fluid level switch

## Removal and Installation

INFOID:000000011781768

WW

### REMOVAL

1. Remove the front fender protector (RH). Refer to [EXT-36, "FENDER PROTECTOR : Removal and Installation"](#).
2. Disconnect harness connector from the front and rear washer motor.
3. Disconnect the front and rear washer outlet tubes.
4. Remove the front and rear washer motor from washer tank.

### INSTALLATION

Installation is in the reverse order of removal.

#### CAUTION:

- Add water up to the top of washer tank inlet after installing. Check that no leaks exist.
- Fill washer tank with specified amount of fluid. Refer to [WW-77, "Specifications"](#).

# WASHER FLUID LEVEL SWITCH

< REMOVAL AND INSTALLATION >

## WASHER FLUID LEVEL SWITCH

Exploded View

INFOID:000000011786525

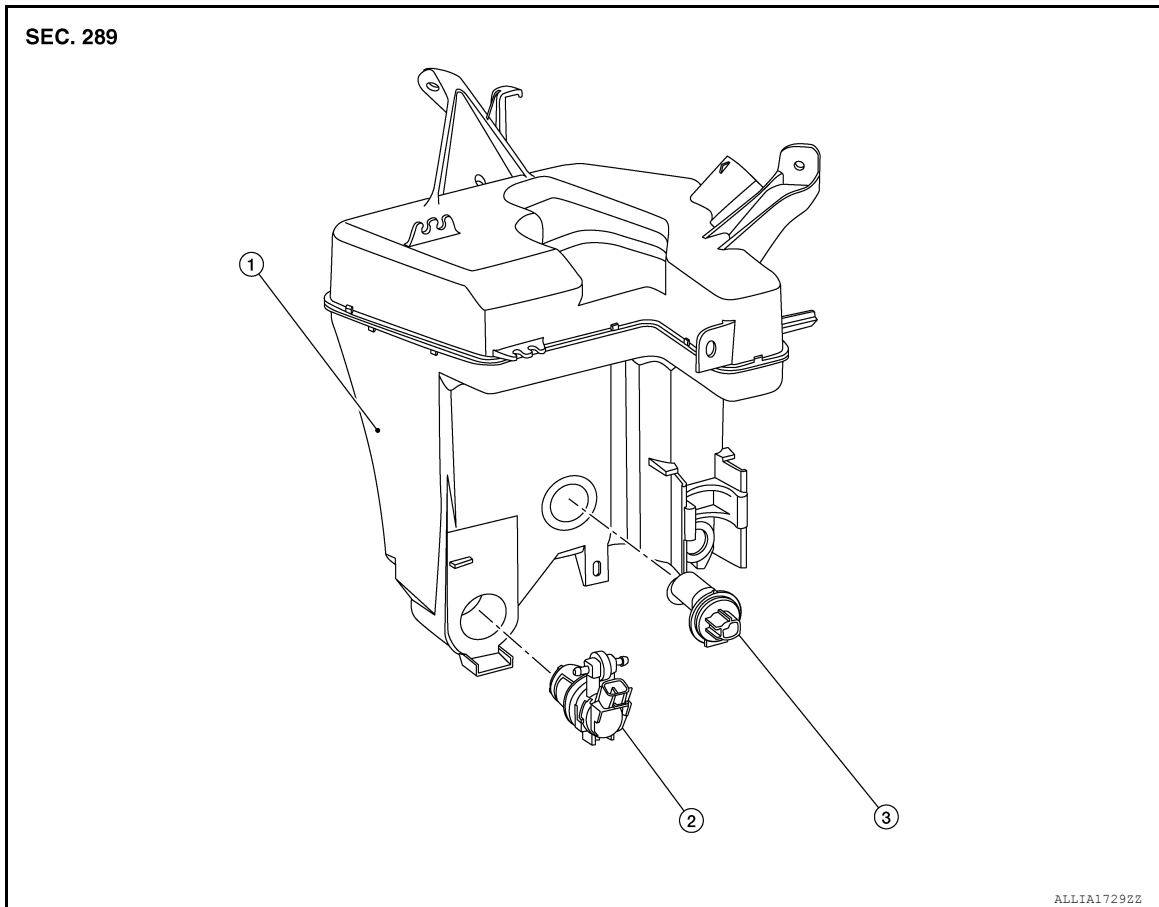

1. Washer tank    2. Front and rear washer motor    3. Washer fluid level switch

## Removal and Installation

INFOID:000000011218088

### REMOVAL

1. Remove the front fender protector (RH). Refer to [EXT-36, "FENDER PROTECTOR : Removal and Installation"](#).
2. Disconnect harness connector from the washer fluid level switch.
3. Remove the washer fluid level switch from washer tank.

### INSTALLATION

Installation is in the reverse order of removal.

#### **CAUTION:**

- Add water up to the top of washer tank inlet after installing. Check that no leaks exist.
- Fill washer tank with specified amount of fluid. Refer to [WW-77, "Specifications"](#).

# FRONT WASHER NOZZLE AND TUBE

< REMOVAL AND INSTALLATION >

## FRONT WASHER NOZZLE AND TUBE

Exploded View

INFOID:000000011218089

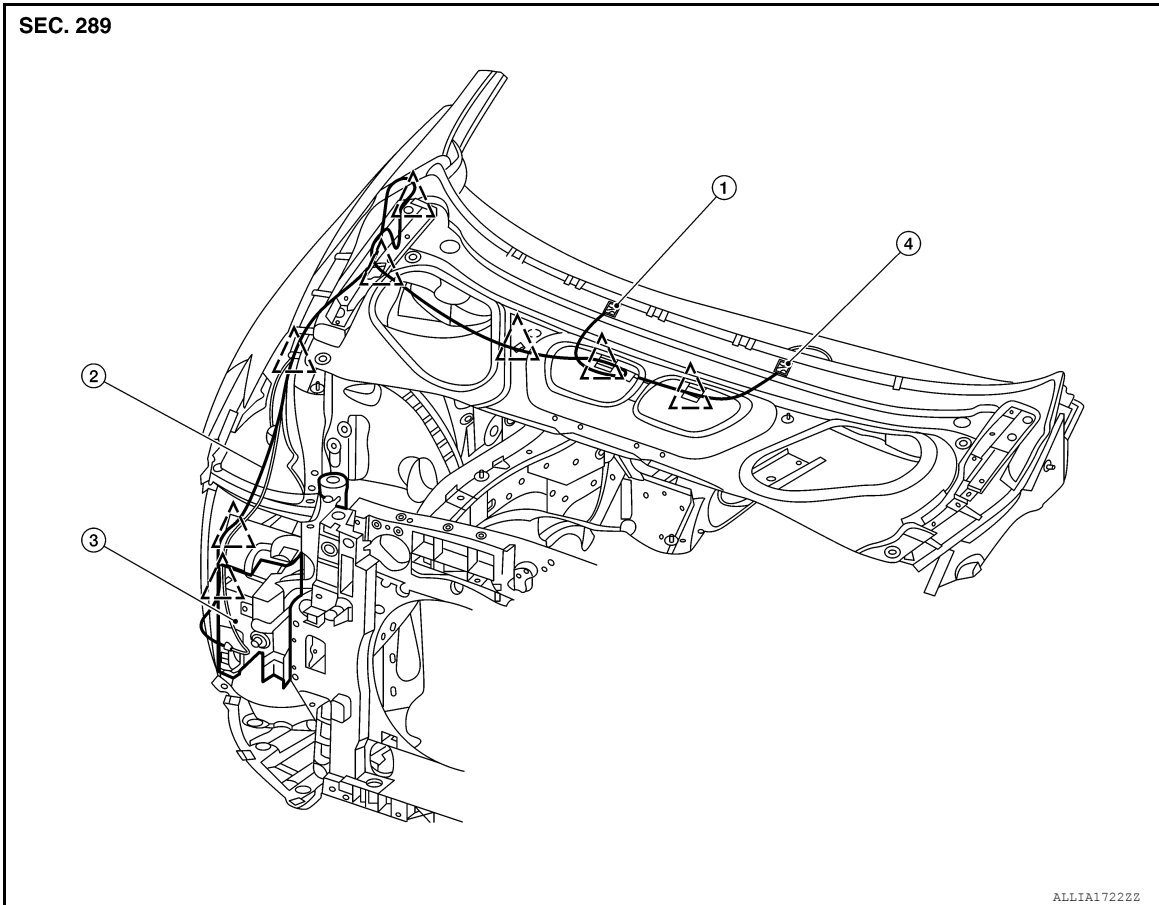

- 1. Front washer nozzle (RH)
- 2. Front washer tube
- 3. Washer tank
- 4. Front washer nozzle (LH)
-  Clip

## FRONT WASHER NOZZLE

### FRONT WASHER NOZZLE : Removal and Installation

INFOID:000000011218090

#### REMOVAL

1. Release the pawl and remove the front washer nozzle from the hood.

: Pawl

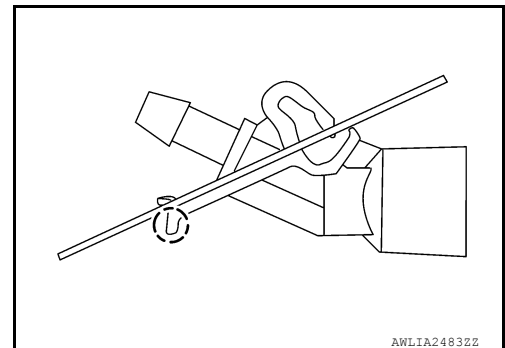

2. Disconnect the front washer tube from the front washer nozzle.

#### INSTALLATION

Installation is in the reverse order of removal.

A  
B  
C  
D  
E  
F  
G  
H  
I  
J  
K  
M  
N  
O  
P

WW

# FRONT WASHER NOZZLE AND TUBE

< REMOVAL AND INSTALLATION >

**CAUTION:**

Adjust the front nozzles to their proper position. Refer to [WW-60, "FRONT WASHER NOZZLE : Adjustment"](#).

## FRONT WASHER NOZZLE : Adjustment

INFOID:000000011551891

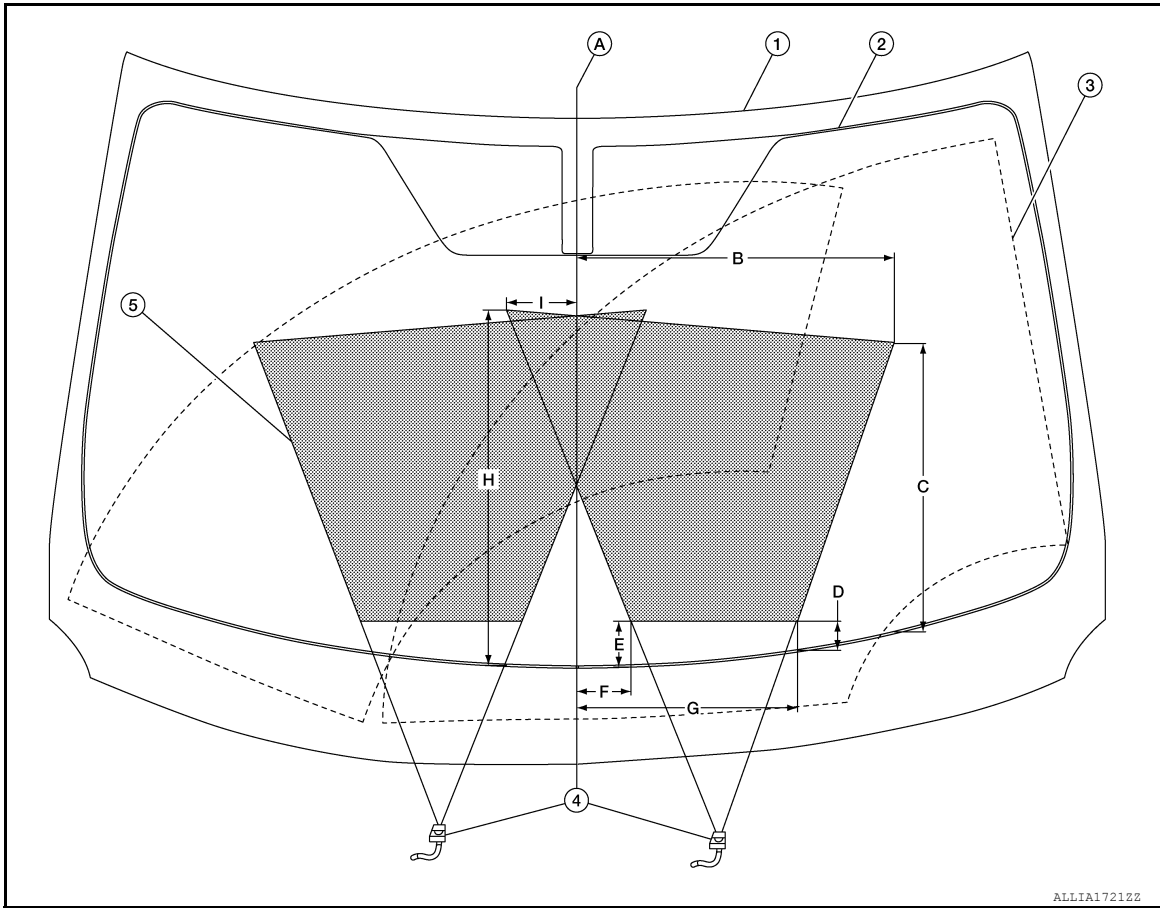

- |                                |                               |                        |
|--------------------------------|-------------------------------|------------------------|
| 1. Windshield glass            | 2. Black printed area line    | 3. Wiping area         |
| 4. Front washer nozzle (RH/LH) | 5. Washer fluid spray pattern | A. Center line         |
| B. 449.1 mm (17.68 in)         | C. 456.7 mm (17.98 in)        | D. 53.6 mm (2.11 in)   |
| E. 74.4 mm (2.93 in)           | F. 77.1 mm (3.04 in)          | G. 303.1 mm (11.93 in) |
| H. 560.7 mm (22.07 in)         | I. 96.3 mm (3.79 in)          |                        |

**NOTE:**

Spray positions for LH shown; RH is symmetrical.

Insert a suitable tool (A) into the front washer nozzle hole (B) and move up/down and left/right to adjust the spray position of each nozzle (1).

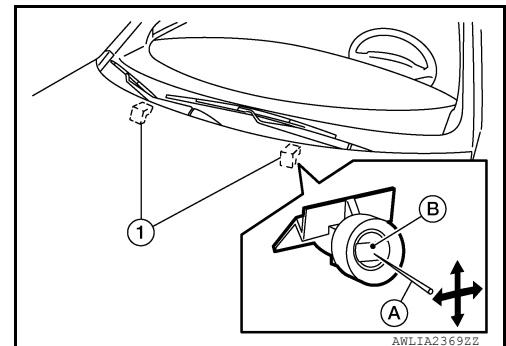

## FRONT WASHER TUBE

# FRONT WASHER NOZZLE AND TUBE

< REMOVAL AND INSTALLATION >

## FRONT WASHER TUBE : Removal and Installation

INFOID:000000011218092

### REMOVAL

1. Remove the hood insulator. Refer to [DLK-265, "Exploded View"](#). A
2. Remove the hoodledge cover (RH). Refer to [DLK-272, "Removal and Installation"](#). B
3. Disconnect the front washer tube from the front washer nozzle. Refer to [WW-59, "FRONT WASHER NOZZLE : Removal and Installation"](#). C
4. Remove the front fender protector (RH). Refer to [DLK-272, "Removal and Installation"](#). D
5. Disconnect the front washer tube from the front and rear washer motor. E
6. Release clips and remove the front washer tube. F

### INSTALLATION

Installation is in the reverse order of removal. G

A  
B  
C  
D  
E  
F  
G  
H  
I  
J  
K  
M  
N  
O  
P

WW

# FRONT WIPER ARM

< REMOVAL AND INSTALLATION >

## FRONT WIPER ARM

Exploded View

INFOID:0000000011218094

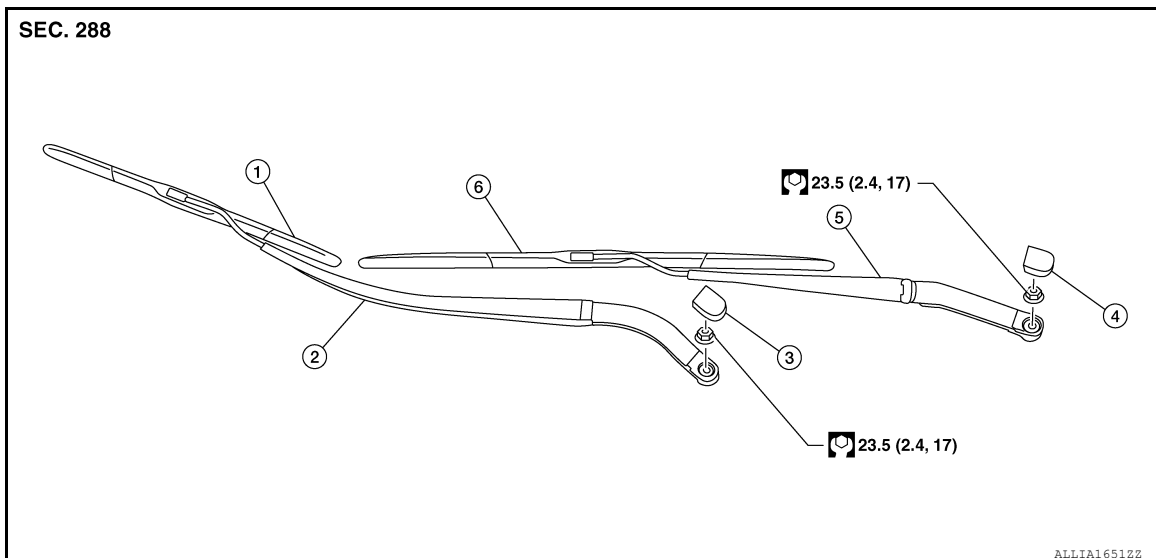

- |                               |                         |                               |
|-------------------------------|-------------------------|-------------------------------|
| 1. Front wiper blade (RH)     | 2. Front wiper arm (RH) | 3. Front wiper arm cover (RH) |
| 4. Front wiper arm cover (LH) | 5. Front wiper arm (LH) | 6. Front wiper blade (LH)     |

## Removal and Installation

INFOID:0000000011218095

### REMOVAL

1. Operate the front wiper arms into the auto stop position.
2. Open the hood.
3. Remove the front wiper arm cover.
4. Remove the front wiper arm nut.
5. Raise the front wiper arm, then remove the front wiper arm.

### INSTALLATION

1. Clean the front wiper arm mount as shown.

**NOTE:**

This will reduce the possibility of wiper arm looseness.

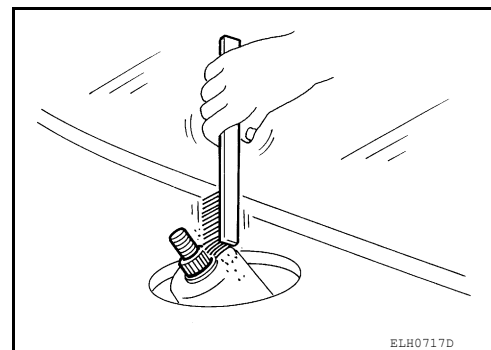

2. Operate front wiper motor to move the front wiper to the auto stop position.
3. Adjust the front wiper blade position. Refer to [WW-62, "Adjustment"](#).
4. Install the front wiper arm and the front wiper arm nut.
5. Install the front wiper arm cover.
6. Check that the front wiper blades stop at the specified position. Refer to [WW-62, "Adjustment"](#).

## Adjustment

INFOID:0000000011218096

### WIPER BLADE POSITION ADJUSTMENT

# FRONT WIPER ARM

## < REMOVAL AND INSTALLATION >

Clearance between the end of cowl top cover/ front fender cover and the top of front wiper blade center.

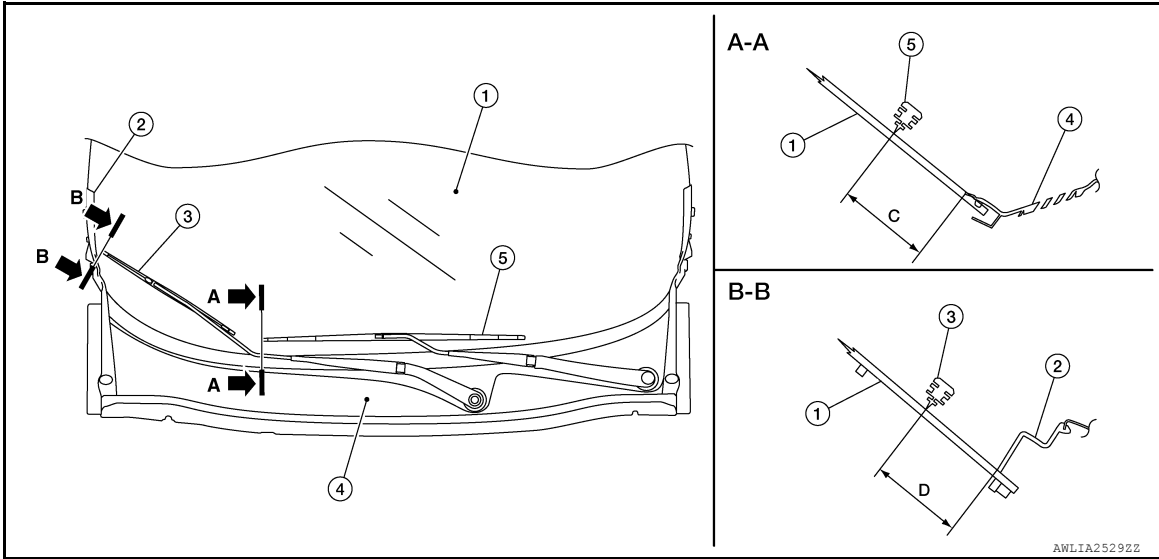

- |   |                           |   |
|---|---------------------------|---|
| 1. Windshield glass                     | 2. Front fender cover     | 3. Front wiper blade (RH)               |
| 4. Cowl top cover                       | 5. Front wiper blade (LH) | C. 41.6 mm ± 7.5 mm (1.64 in ± 0.30 in) |
| D. 44.2 mm ± 7.5 mm (1.74 in ± 0.30 in) |                           |   |

A  
B  
C  
D  
E  
F  
G  
H  
I  
J  
K  
L  
M  
N  
O  
P

WW

# FRONT WIPER BLADE

< REMOVAL AND INSTALLATION >

## FRONT WIPER BLADE

Exploded View

INFOID:000000011218097

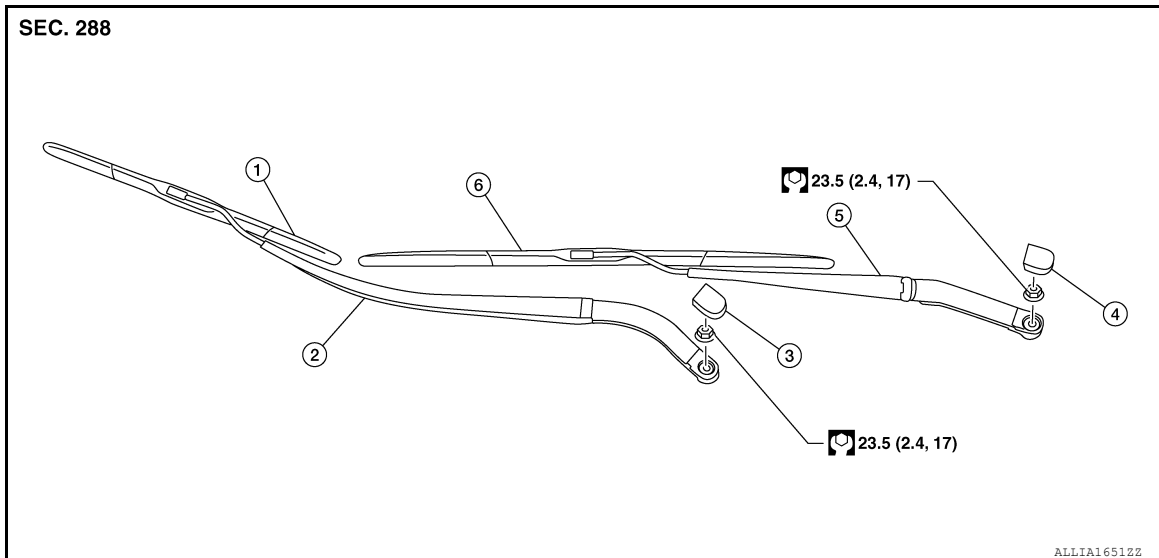

- |                               |                         |                               |
|-------------------------------|-------------------------|-------------------------------|
| 1. Front wiper blade (RH)     | 2. Front wiper arm (RH) | 3. Front wiper arm cover (RH) |
| 4. Front wiper arm cover (LH) | 5. Front wiper arm (LH) | 6. Front wiper blade (LH)     |

## FRONT WIPER BLADE

### FRONT WIPER BLADE : Removal and Installation

INFOID:000000011218098

#### REMOVAL

1. Lift the front wiper arm and blade assembly away from the windshield glass.
2. Release tab (A), then move the front wiper blade as shown.

**CAUTION:**

**Be careful not to drop the wiper arm onto the windshield glass.**

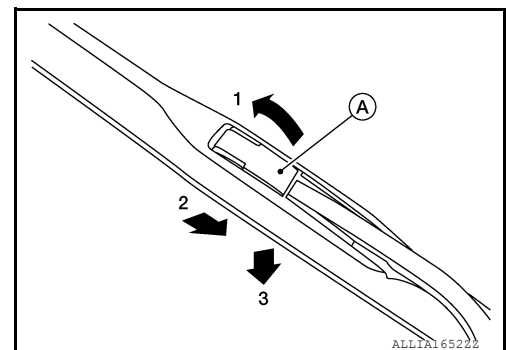

#### INSTALLATION

1. Insert the front wiper blade onto the front wiper arm until it clicks into place.
2. Lower the front wiper arm and blade assembly onto the windshield glass.

## FRONT WIPER BLADE REFILL

### FRONT WIPER BLADE REFILL : Removal and Installation

INFOID:000000011550463

#### REMOVAL

1. Remove the front wiper blade. Refer to [WW-64, "FRONT WIPER BLADE : Removal and Installation"](#).

**CAUTION:**

**Be careful not to drop the front wiper arm onto the windshield glass.**



# FRONT WIPER BLADE

## < REMOVAL AND INSTALLATION >

2. Hold the front wiper blade refill lip at the end (A) of the front wiper blade (1) with a suitable tool (B) as shown, and pull it firmly in the direction (C).  
(D): U clip (part of front wiper blade)

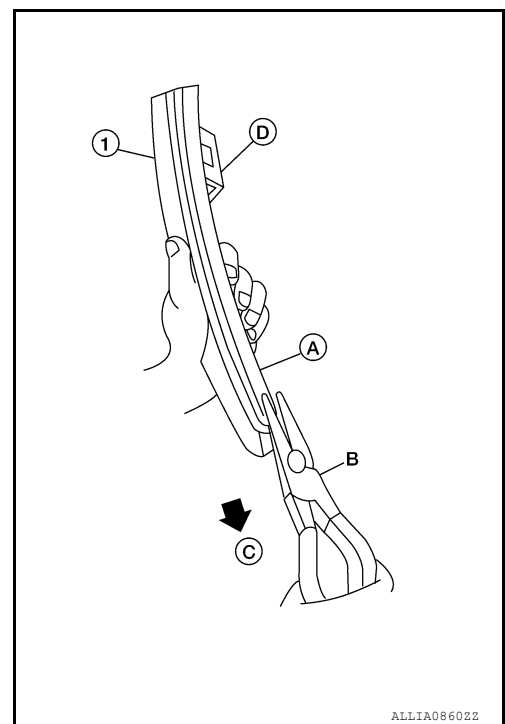

- If the front wiper blade refill lip is torn due to wear, insert a suitable tool (A) into the space between the end of the front wiper blade refill (1) and the front wiper blade (2) and pull the front wiper blade refill (1) out as shown.

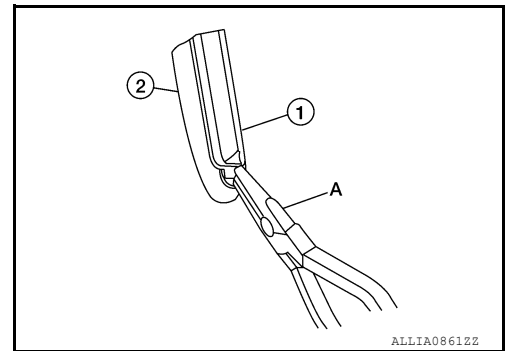

## INSTALLATION

1. If the rib (A) has become detached from the front wiper blade refill (1), check that the curve of the rib (A) is in the same direction as the curve of the front wiper blade refill (1) and insert the rib (A) into the slit (B) in the front wiper blade refill (1) as shown.

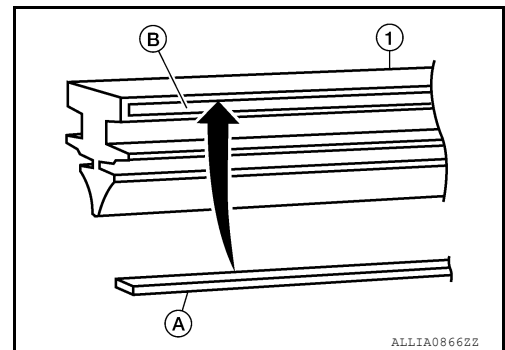

A  
B  
C  
D  
E  
F  
G  
H  
I  
J  
K  
L  
M  
N  
O  
P

WW

# FRONT WIPER BLADE

## < REMOVAL AND INSTALLATION >

- If the rib (A) has a notch (B), insert the rib (A) into the front wiper blade refill (1) so the notch (B) fits over the protrusion (C) in the front wiper blade refill (1) as shown.

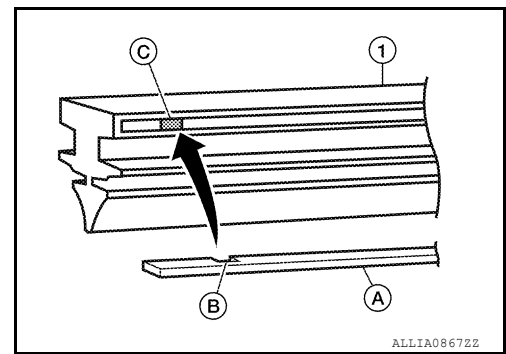

2. Insert the front wiper blade refill (1) tip into the end of the front wiper blade (2) in the direction (C). Push the front wiper blade refill (1) in while pressing it into the end of the front wiper blade (2) as shown. After the front wiper blade refill is fully inserted, remove the holder (B).  
(A): Tab (part of front wiper blade) (2)

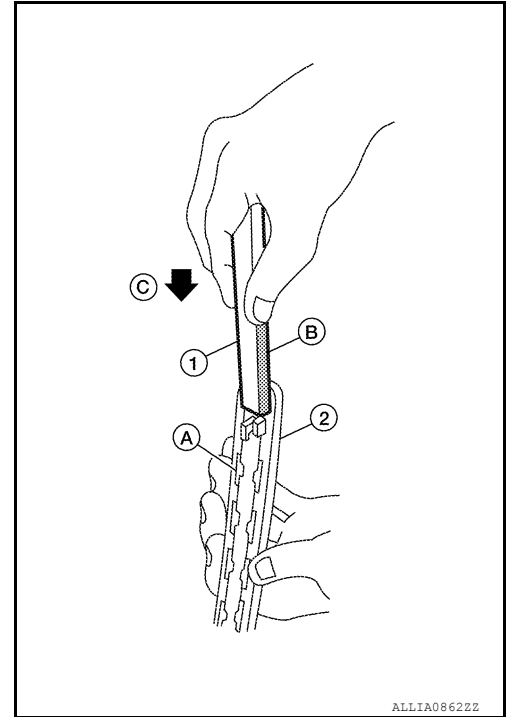

- Make sure to slide the refill into the front wiper blade so that the front wiper blade refill is held by the tabs (A) on the front wiper blade as shown.

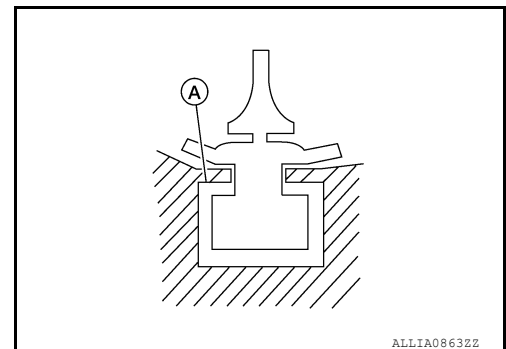

## FRONT WIPER BLADE

### < REMOVAL AND INSTALLATION >

3. Push the front wiper blade refill (1) until the tabs on the front wiper blade (2) fit into the stoppers (A) in the end of the front wiper blade refill (1). Make sure the LOCK mark (B) on the front wiper blade refill (1) is aligned with the lock point symbol (C) on the front wiper blade (2) as shown.

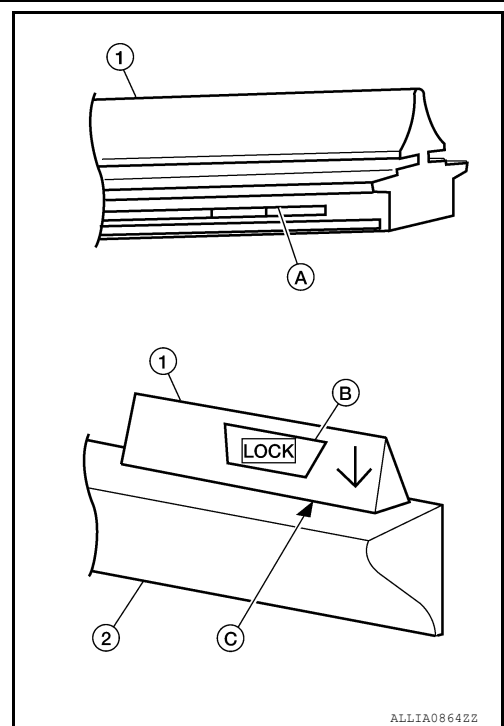

4. Before installing the front wiper blade, make sure that the front wiper blade refill (1) end is fully covered by the front wiper blade (2) in area (A) and locked at point (C).

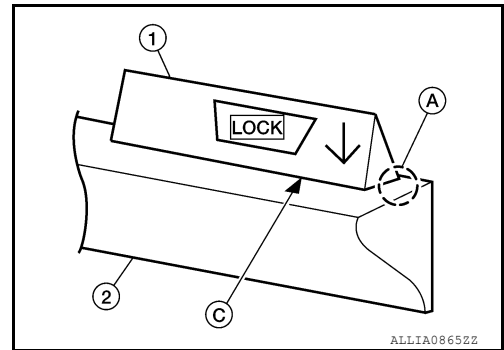

5. Install the front wiper blade. Refer to [WW-64. "FRONT WIPER BLADE : Removal and Installation"](#).

A  
B  
C  
D  
E  
F  
G  
H  
I  
J  
K  
M  
N  
O  
P

WW

# FRONT WIPER DRIVE ASSEMBLY

< REMOVAL AND INSTALLATION >

## FRONT WIPER DRIVE ASSEMBLY

Exploded View

INFOID:000000011218099

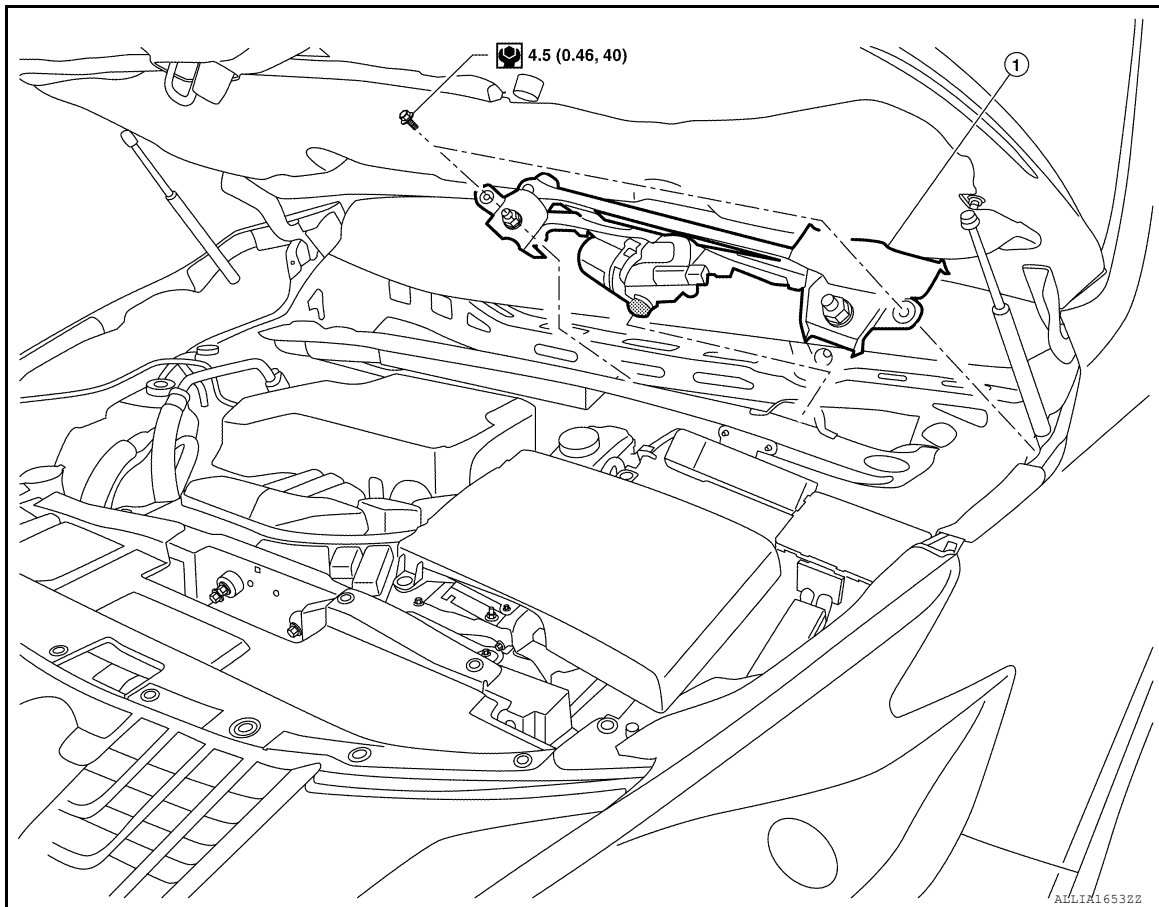

1. Front wiper drive assembly

## Removal and Installation

INFOID:000000011218100

### REMOVAL

1. Remove the cowl top cover. Refer to [EXT-34. "Removal and Installation - Cowl Top Cover"](#).
2. Disconnect the harness connector from the front wiper motor.
3. Remove the bolts from the front wiper drive assembly.
4. Remove the front wiper drive assembly (1) in the sequence shown.

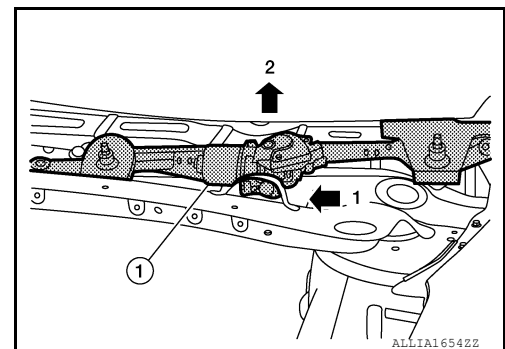

### INSTALLATION

Installation is in the reverse order of removal.

# FRONT WIPER MOTOR

< REMOVAL AND INSTALLATION >

## FRONT WIPER MOTOR

Exploded View

INFOID:000000011550465

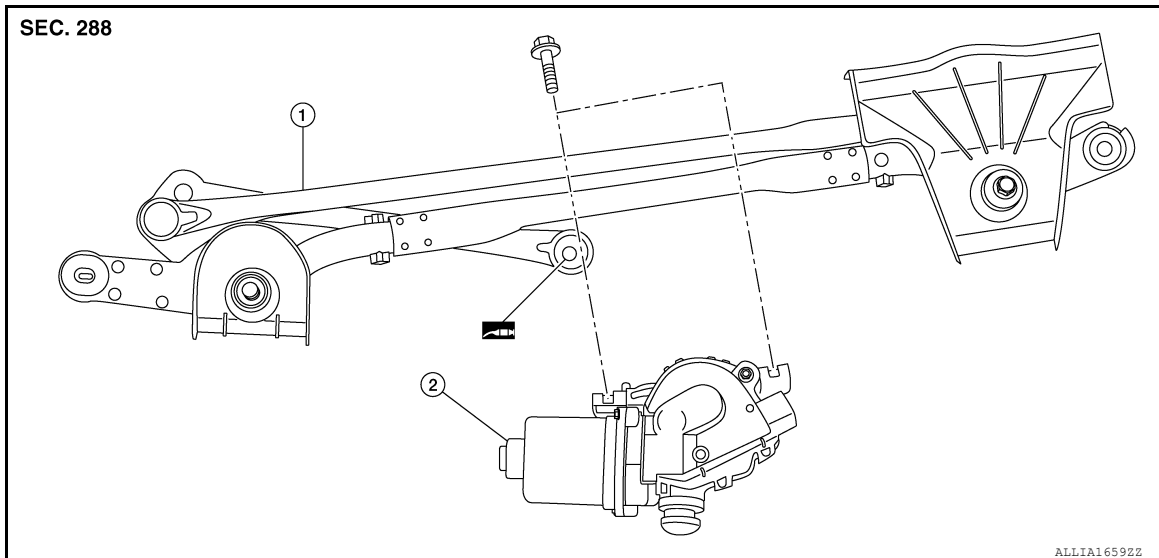

1. Front wiper drive

2. Front wiper motor



Grease

## Removal and Installation

INFOID:000000011550466

### REMOVAL

1. Remove the front drive assembly. Refer to [WW-68. "Removal and Installation"](#).
2. Remove bolts and the front wiper motor.

### INSTALLATION

Installation is in the reverse order of removal.

A  
B  
C  
D  
E  
F  
G  
H  
I  
J  
K

WW

## WIPER AND WASHER SWITCH

< REMOVAL AND INSTALLATION >

---

### WIPER AND WASHER SWITCH

#### Removal and Installation

INFOID:000000011218103

The wiper and washer switch are serviced as an assembly with the combination switch assembly. Refer to [BCS-83. "Removal and Installation"](#).

# REAR WIPER ARM

< REMOVAL AND INSTALLATION >

## REAR WIPER ARM

Exploded View

INFOID:000000011218104

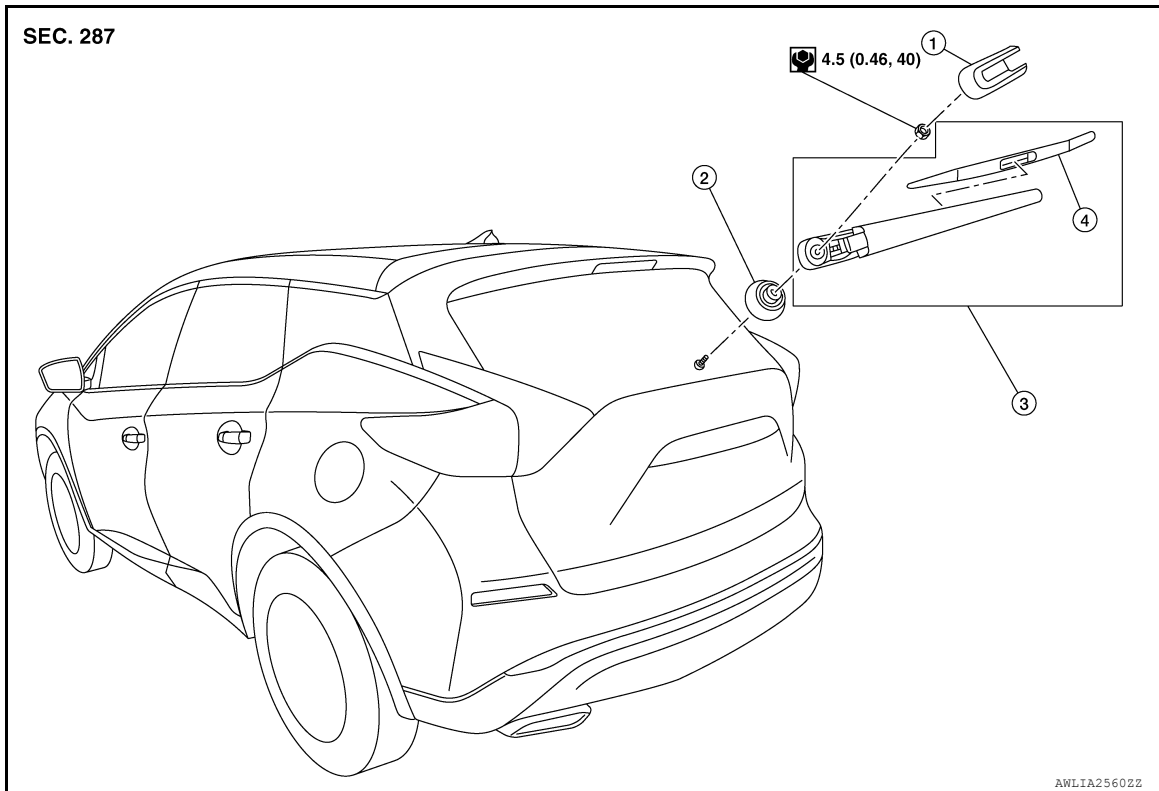

1. Rear wiper arm cover
4. Rear wiper blade

2. Seal

3. Rear wiper arm assembly

## Removal and Installation

INFOID:000000011218105

### REMOVAL

1. Operate the rear wiper arm into the auto stop position.
2. Remove the rear wiper arm cover.
3. Remove the rear wiper arm nut.
4. Remove the rear wiper arm assembly.

### INSTALLATION

1. Clean the rear wiper arm mount as shown.  
**NOTE:**  
This will reduce the possibility of wiper arm looseness.

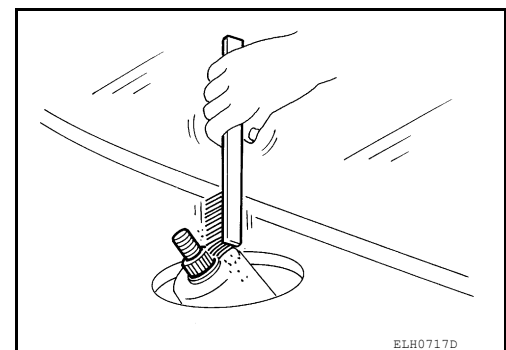

2. Operate the rear wiper motor to move it to the auto stop position.
3. Install the rear wiper arm by positioning the rear wiper blade in alignment with rear window defogger wire then tighten the rear wiper arm nut to specification. Refer to [WW-72. "Inspection"](#).

A  
B  
C  
D  
E  
F  
G  
H  
I  
J  
K  
M  
N  
O  
P

WW

# REAR WIPER ARM

## < REMOVAL AND INSTALLATION >

4. Install the rear wiper arm cover.
5. Check that the rear wiper blade stops at the specified position. Refer to [WW-72, "Inspection"](#).

### Inspection

INFOID:000000011551919

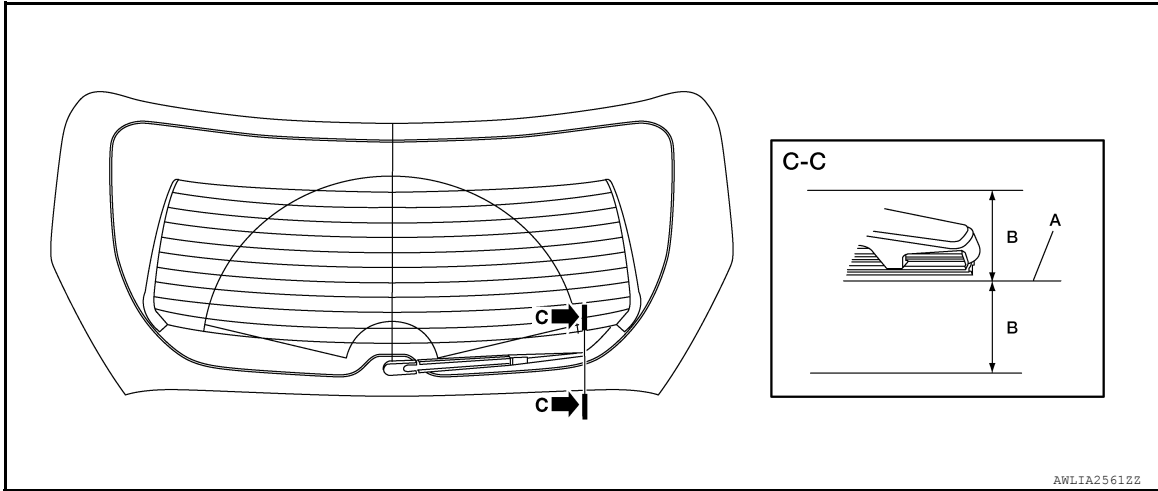

A. Rear window defogger wire

B. 7.5 mm (0.30 in)



# REAR WIPER MOTOR

< REMOVAL AND INSTALLATION >

## REAR WIPER MOTOR

Exploded View

INFOID:000000011218107

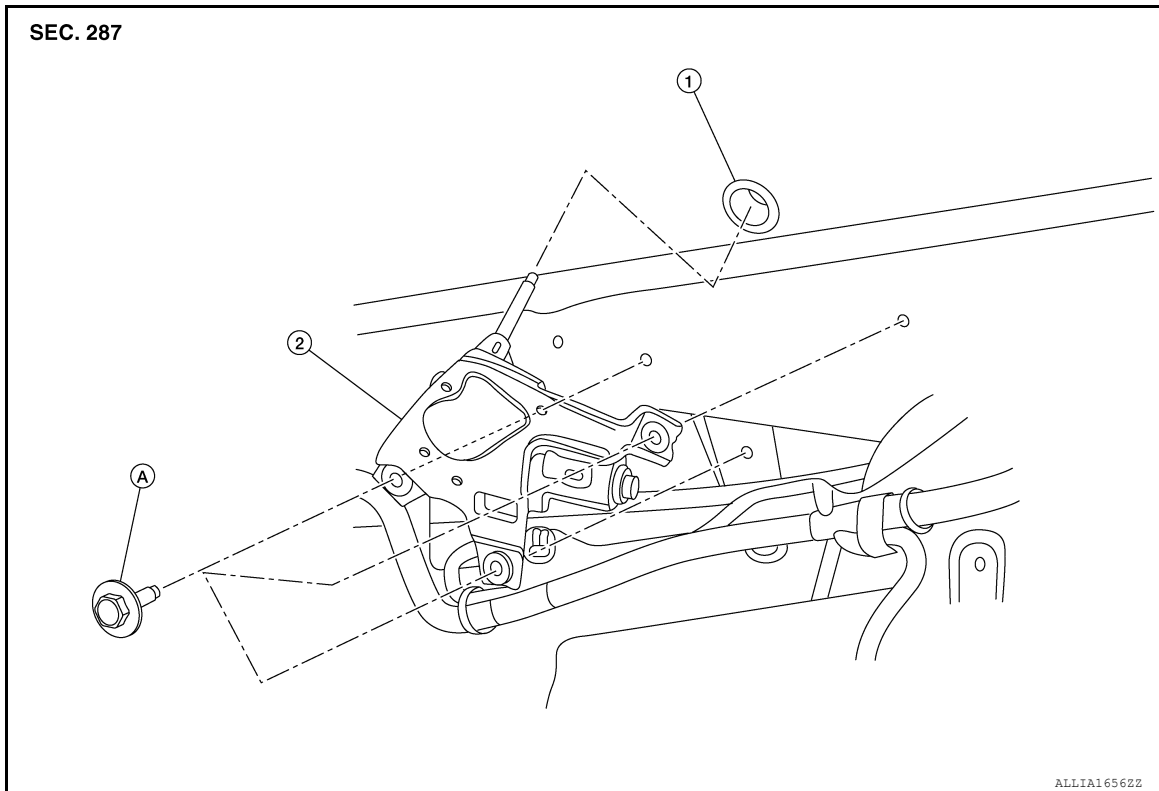

1. Seal

2. Rear wiper motor

A. Refer to INSTALLATION

### Removal and Installation

INFOID:000000011218108

#### REMOVAL

1. Remove the rear wiper arm. Refer to [WW-71, "Removal and Installation"](#).
2. Remove the back door lower finisher. Refer to [INT-34, "BACK DOOR LOWER FINISHER : Removal and Installation"](#).
3. Disconnect the harness connector from the rear wiper motor.
4. Remove the rear wiper motor bolts.
5. Remove the rear wiper motor.

#### INSTALLATION

Installation is in the reverse order of removal.

#### CAUTION:

**Tighten the rear wiper motor bolts to specification in the sequence shown.**

**Washer motor bolts : 4.5 N·m (0.46 kg-m, 40 in-lb)**

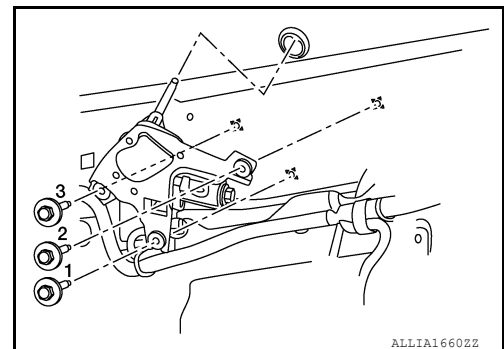

# REAR WASHER NOZZLE AND TUBE

< REMOVAL AND INSTALLATION >

## REAR WASHER NOZZLE AND TUBE

### Washer Tube Layout

INFOID:000000011218109

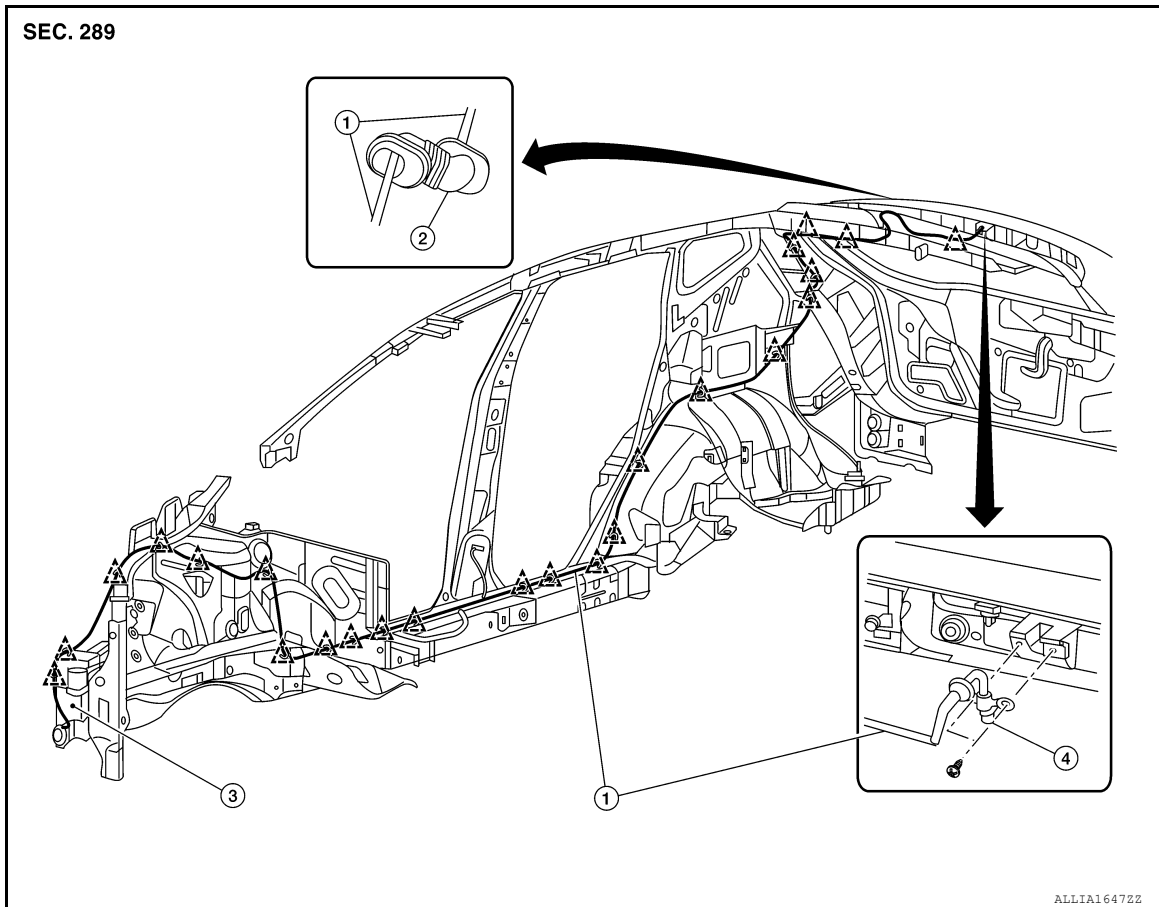

- |                       |            |                |
|-----------------------|------------|----------------|
| 1. Rear washer tube   | 2. Grommet | 3. Washer tank |
| 4. Rear washer nozzle | △ Clip     |                |

## REAR WASHER TUBE

### REAR WASHER TUBE : Removal and Installation

INFOID:000000011218110

#### REMOVAL

1. Remove the luggage side lower finisher (RH). Refer to [INT-30, "LUGGAGE SIDE LOWER FINISHER : Removal and Installation"](#).
2. Remove the center pillar lower finisher (RH). Refer to [INT-21, "CENTER PILLAR LOWER FINISHER : Removal and Installation"](#).
3. Release clips using a suitable tool and remove rear seat belt center retractor finisher. Refer to [INT-26, "Exploded View"](#).
4. Using a suitable tool release the headlining rear clips and lower the headlining. Refer to [INT-26, "Exploded View"](#).
5. Remove the dash side finisher (RH). Refer to [INT-23, "DASH SIDE FINISHER : Removal and Installation"](#).
6. Remove the fender protector (RH). Refer to [EXT-36, "FENDER PROTECTOR : Exploded View"](#).
7. Disconnect the rear washer tube from the rear washer nozzle.
8. Disconnect the rear washer tube from the washer tank.
9. Remove the rear washer tube clips and remove rear washer tube.

#### INSTALLATION

# REAR WASHER NOZZLE AND TUBE

## < REMOVAL AND INSTALLATION >

Installation is in the reverse order of removal.

### REAR WASHER TUBE : Inspection

INFOID:000000011218112

#### INSPECTION

Check that air can pass through the nozzle by blowing into the nozzle, and check that air cannot flow in the opposite direction.

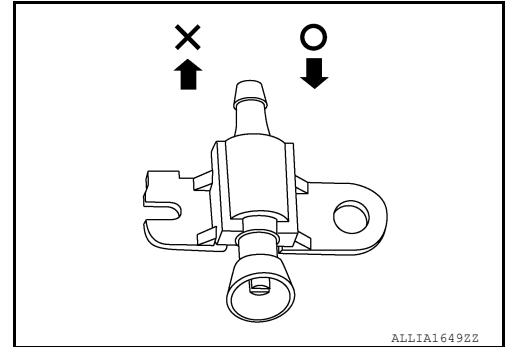

If operating properly, the spray positions should match the position shown. If spray position does not match, confirm the rear washer nozzle is properly seated and working properly. If the spray position still does not match as shown, then replace the rear washer nozzle. Refer to [WW-75, "REAR WASHER NOZZLE : Removal and Installation"](#).

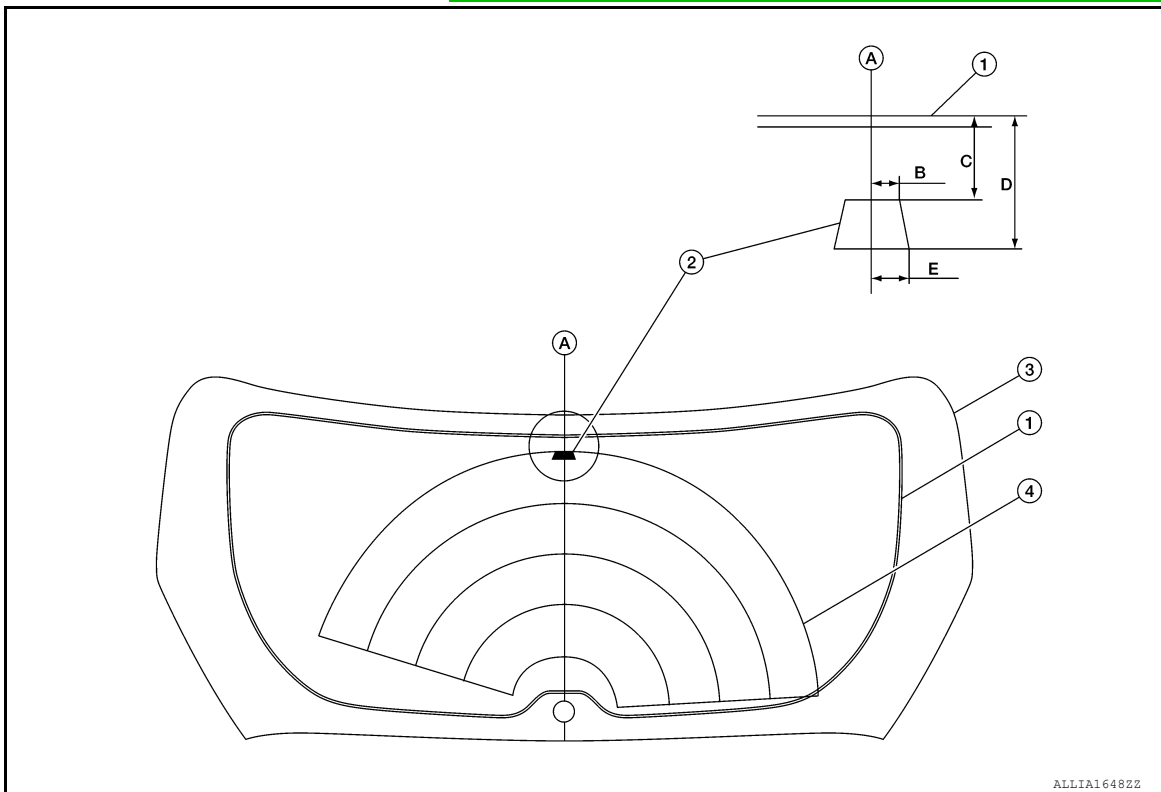

- |                      |                      |                     |
|----------------------|----------------------|---------------------|
| 1. Black print       | 2. Spray target area | 3. Back door glass  |
| 4. Wiper area        | A. Center line       | B. 7.0 mm (0.28 in) |
| C. 21.7 mm (0.85 in) | D. 34.6 mm (1.36 in) | E. 9.9 mm (0.39 in) |

## REAR WASHER NOZZLE

### REAR WASHER NOZZLE : Removal and Installation

INFOID:000000011218111

#### REMOVAL

A  
B  
C  
D  
E  
F  
G  
H  
I  
J  
K  
L  
M  
N  
O  
P

WW

## REAR WASHER NOZZLE AND TUBE

### < REMOVAL AND INSTALLATION >

---

1. Remove the rear spoiler. Refer to [EXT-51. "Removal and Installation"](#).
2. Disconnect the rear washer tube from the rear washer nozzle.
3. Remove the rear washer nozzle bolt and remove the rear washer nozzle.

### INSTALLATION

Installation is in the reverse order of removal.

# SERVICE DATA AND SPECIFICATIONS (SDS)

< SERVICE DATA AND SPECIFICATIONS (SDS)

## SERVICE DATA AND SPECIFICATIONS (SDS)

SERVICE DATA AND SPECIFICATIONS (SDS)

Specifications

INFOID:000000011218113

WINDSHIELD WASHER FLUID

Windshield washer fluid capacity	4.6 ℓ (4 7/8 US qt, 4 Imp qt)
Windshield washer fluid specification	Refer to <a href="#">MA-11. "Fluids and Lubricants"</a> .

A  
B  
C  
D  
E  
F  
G  
H  
I  
J  
K  
M  
N  
O  
P

WW