

**SECTION BR**  
**BRAKE SYSTEM**

A  
B  
C  
D  
E

**CONTENTS**

<b>PRECAUTION</b> .....	<b>3</b>	<b>PERIODIC MAINTENANCE</b> .....	<b>13</b>
<b>PRECAUTIONS</b> .....	<b>3</b>	<b>BRAKE PEDAL</b> .....	<b>13</b>
Precaution for Supplemental Restraint System (SRS) "AIR BAG" and "SEAT BELT PRE-TENSIONER" .....	3	Adjustment .....	13
Precaution for Procedure without Cowl Top Cover.....	3	<b>BRAKE FLUID</b> .....	<b>14</b>
Precaution for Brake System .....	3	Drain and Refill .....	14
<b>PREPARATION</b> .....	<b>5</b>	Bleeding Brake System .....	14
<b>PREPARATION</b> .....	<b>5</b>	<b>FRONT DISC BRAKE</b> .....	<b>16</b>
Special Service Tool .....	5	<b>BRAKE PAD</b> .....	<b>16</b>
Commercial Service Tool .....	5	BRAKE PAD : Inspection .....	16
<b>SYMPTOM DIAGNOSIS</b> .....	<b>6</b>	BRAKE PAD : Brake Burnishing .....	16
<b>NOISE, VIBRATION AND HARSHNESS (NVH) TROUBLESHOOTING</b> .....	<b>6</b>	<b>DISC BRAKE ROTOR</b> .....	<b>16</b>
NVH Troubleshooting Chart .....	6	DISC BRAKE ROTOR : Inspection .....	16
<b>BASIC INSPECTION</b> .....	<b>7</b>	DISC BRAKE ROTOR : Brake Burnishing .....	17
<b>BRAKE PEDAL</b> .....	<b>7</b>	<b>REAR DISC BRAKE</b> .....	<b>18</b>
Inspection .....	7	<b>BRAKE PAD</b> .....	<b>18</b>
<b>BRAKE FLUID</b> .....	<b>8</b>	BRAKE PAD : Inspection .....	18
Inspection .....	8	BRAKE PAD : Brake Burnishing .....	18
<b>BRAKE MASTER CYLINDER</b> .....	<b>9</b>	<b>DISC BRAKE ROTOR</b> .....	<b>18</b>
Inspection .....	9	DISC BRAKE ROTOR : Inspection .....	18
<b>BRAKE BOOSTER</b> .....	<b>10</b>	DISC BRAKE ROTOR : Brake Burnishing .....	19
Inspection .....	10	<b>REMOVAL AND INSTALLATION</b> .....	<b>20</b>
<b>FRONT DISC BRAKE</b> .....	<b>11</b>	<b>BRAKE PEDAL</b> .....	<b>20</b>
<b>DISC BRAKE ROTOR</b> .....	<b>11</b>	Exploded View .....	20
DISC BRAKE ROTOR : Inspection .....	11	Removal and Installation .....	20
<b>REAR DISC BRAKE</b> .....	<b>12</b>	<b>BRAKE PIPING</b> .....	<b>22</b>
<b>DISC BRAKE ROTOR</b> .....	<b>12</b>	<b>FRONT</b> .....	<b>22</b>
DISC BRAKE ROTOR : Inspection .....	12	FRONT : Exploded View .....	22
		FRONT : Hydraulic Piping .....	24
		FRONT : Removal and Installation .....	24
		<b>REAR</b> .....	<b>25</b>
		REAR : Exploded View .....	26

**BR**

G  
H  
I  
J  
K  
L  
M  
N  
O  
P

REAR : Hydraulic Piping .....	26	BRAKE PAD : Exploded View .....	41
REAR : Removal and Installation .....	27	BRAKE PAD : Removal and Installation .....	41
<b>BRAKE MASTER CYLINDER .....</b>	<b>29</b>	<b>BRAKE CALIPER ASSEMBLY .....</b>	<b>43</b>
Exploded View .....	29	BRAKE CALIPER ASSEMBLY : Exploded View ...	43
Removal and Installation .....	29	BRAKE CALIPER ASSEMBLY : Removal and In-	
Disassembly and Assembly .....	30	stallation .....	43
<b>BRAKE BOOSTER .....</b>	<b>32</b>	<b>DISC BRAKE ROTOR .....</b>	<b>45</b>
Exploded View .....	32	DISC BRAKE ROTOR : Exploded View .....	45
Removal and Installation .....	32	DISC BRAKE ROTOR : Removal and Installation...	45
<b>VACUUM LINES .....</b>	<b>34</b>	<b>UNIT DISASSEMBLY AND ASSEMBLY ...</b>	<b>46</b>
Exploded View .....	34	<b>FRONT DISC BRAKE .....</b>	<b>46</b>
Removal and Installation .....	34	Exploded View .....	46
<b>FRONT DISC BRAKE .....</b>	<b>36</b>	Disassembly and Assembly .....	46
<b>BRAKE PAD .....</b>	<b>36</b>	<b>REAR DISC BRAKE .....</b>	<b>49</b>
BRAKE PAD : Exploded View .....	36	Exploded View .....	49
BRAKE PAD : Removal and Installation .....	36	Disassembly and Assembly .....	49
<b>BRAKE CALIPER ASSEMBLY .....</b>	<b>37</b>	<b>SERVICE DATA AND SPECIFICATIONS</b>	
BRAKE CALIPER ASSEMBLY : Exploded View ...	37	<b>(SDS) .....</b>	<b>52</b>
BRAKE CALIPER ASSEMBLY : Removal and In-		<b>SERVICE DATA AND SPECIFICATIONS</b>	
stallation .....	38	<b>(SDS) .....</b>	<b>52</b>
<b>DISC BRAKE ROTOR .....</b>	<b>39</b>	General Specifications .....	52
DISC BRAKE ROTOR : Exploded View .....	40	Brake Pedal .....	52
DISC BRAKE ROTOR : Removal and Installation..	40	Check Valve .....	53
<b>REAR DISC BRAKE .....</b>	<b>41</b>	Brake Booster .....	53
<b>BRAKE PAD .....</b>	<b>41</b>	Front Disc Brake .....	53
		Rear Disc Brake .....	54

# PRECAUTIONS

< PRECAUTION >

## PRECAUTION

### PRECAUTIONS

#### Precaution for Supplemental Restraint System (SRS) "AIR BAG" and "SEAT BELT PRE-TENSIONER"

INFOID:000000013380602

The Supplemental Restraint System such as "AIR BAG" and "SEAT BELT PRE-TENSIONER", used along with a front seat belt, helps to reduce the risk or severity of injury to the driver and front passenger for certain types of collision. Information necessary to service the system safely is included in the SR and SB section of this Service Manual.

#### **WARNING:**

- To avoid rendering the SRS inoperative, which could increase the risk of personal injury or death in the event of a collision which would result in air bag inflation, it is recommended that all maintenance and repair be performed by an authorized NISSAN/INFINITI dealer.
- Improper repair, including incorrect removal and installation of the SRS, can lead to personal injury caused by unintentional activation of the system. For removal of Spiral Cable and Air Bag Module, see the SR section.
- Do not use electrical test equipment on any circuit related to the SRS unless instructed to in this Service Manual. SRS wiring harnesses can be identified by yellow and/or orange harnesses or harness connectors.

#### PRECAUTIONS WHEN USING POWER TOOLS (AIR OR ELECTRIC) AND HAMMERS

#### **WARNING:**

- When working near the Air Bag Diagnosis Sensor Unit or other Air Bag System sensors with the Ignition ON or engine running, DO NOT use air or electric power tools or strike near the sensor(s) with a hammer. Heavy vibration could activate the sensor(s) and deploy the air bag(s), possibly causing serious injury.
- When using air or electric power tools or hammers, always switch the Ignition OFF, disconnect the battery or batteries, and wait at least three minutes before performing any service.

#### Precaution for Procedure without Cowl Top Cover

INFOID:000000012894306

When performing the procedure after removing cowl top cover, cover the lower end of windshield with urethane, etc. to prevent damage to windshield.

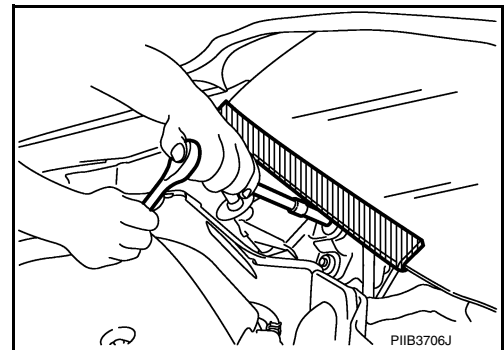

#### Precaution for Brake System

INFOID:000000012894307

#### **WARNING:**

Clean any dust from the front brake and rear brake using a vacuum dust collector. Do not blow by compressed air.

- Brake fluid use refer to [MA-12. "Fluids and Lubricants"](#).
- Do not reuse drained brake fluid.
- Do not spill or splash brake fluid on painted surfaces. Brake fluid may seriously damage paint. Wipe it off immediately and wash with water if it gets on a painted surface.
- Always clean with new brake fluid when cleaning the master cylinder, brake caliper and other components.
- Do not use mineral oils such as gasoline or light oil to clean. They may damage rubber parts and cause improper operation.
- Always loosen the brake tube flare nut with a flare nut wrench.

## PRECAUTIONS

### < PRECAUTION >

- Tighten the brake tube flare nut to the specified torque with a flare nut crowfoot (A) and torque wrench (B).
- Always confirm the specified tightening torque when installing the brake pipes.
- Turn the ignition switch OFF and disconnect the ABS actuator and electric unit (control unit) connector or the battery negative terminal before performing the work.
- Always connect the battery terminal when moving the vehicle.
- Check that no brake fluid leakage is present after replacing the parts.
- Check for bends, cracks and damage to the brake pedal. Adjust brake pedal if it is outside the standard value.
- Burnish the brake contact surfaces after refinishing or replacing rotors, after replacing pads, or if a soft pedal occurs at very low mileage.
- Front brake: refer to [BR-17, "DISC BRAKE ROTOR : Brake Burnishing"](#).
- Rear brake: refer to [BR-19, "DISC BRAKE ROTOR : Brake Burnishing"](#).

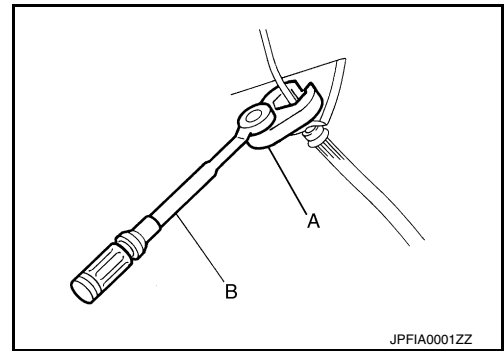

# PREPARATION

< PREPARATION >

## PREPARATION

### PREPARATION

#### Special Service Tool

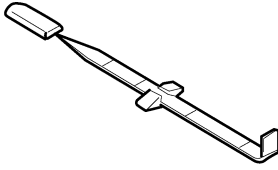
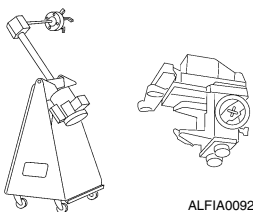

INFOID:0000000012894308

The actual shape of the tools may differ from those illustrated here.

Tool number (TechMate No.) Tool name	Description
<p>— (J-46532) Brake height tool</p>  <p style="text-align: center;">LFIA0227E</p>	<p>Measuring brake pedal height</p>
<p>38-PFM92 ( — ) ProCut™ PFM Series Lathe</p>  <p style="text-align: center;">ALFIA0092ZZ</p>	<p>Refinishing rotors</p>

#### Commercial Service Tool

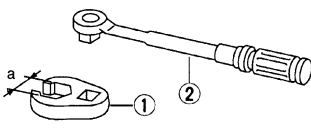
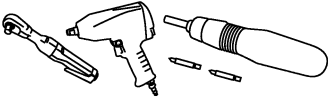
INFOID:0000000012894309

Tool name	Description
<p>1. Flare nut crowfoot 2. Torque wrench</p>  <p style="text-align: center;">S-NT360</p>	<p>Tightening brake tube flare nuts <b>a: 10 mm (0.39 in)/12 mm (0.47 in)</b></p>
<p>Power tool</p>  <p style="text-align: center;">PIB1407E</p>	<p>Loosening nuts, screws and bolts</p>
<p>Vacuum pump</p>  <p style="text-align: center;">ZZC1313D</p>	<ul style="list-style-type: none"> <li>• Air tight</li> <li>• Inspection of check valve</li> </ul>

# NOISE, VIBRATION AND HARSHNESS (NVH) TROUBLESHOOTING

< SYMPTOM DIAGNOSIS >

## SYMPTOM DIAGNOSIS

### NOISE, VIBRATION AND HARSHNESS (NVH) TROUBLESHOOTING

#### NVH Troubleshooting Chart

INFOID:000000012894310

Use the chart below to find the cause of the symptom. If necessary, repair or replace these parts.

Symptom	BRAKE	Possible cause and SUSPECTED PARTS																	
		Brake pad - damaged	Brake pad - uneven wear	Shims damaged	Disc brake rotor imbalance	Disc brake rotor damage	Disc brake rotor runout	Disc brake rotor deformation	Disc brake rotor deflection	Disc brake rotor rust	Disc brake rotor thickness variation	PROPELLER SHAFT	DIFFERENTIAL	AXLE	SUSPENSION	TIRE	WHEEL	DRIVE SHAFT	STEERING
		x	x	x								x	x	x	x	x	x	x	x
					x							x		x	x	x	x	x	x
					x	x	x	x	x	x	x			x	x	x			x
Reference page		BR-11, BR-12			BR-11, BR-12, BR-16, BR-18	BR-11, BR-12, BR-16, BR-18	BR-11, BR-12	BR-11, BR-12	BR-11, BR-12	BR-11, BR-12	BR-11, BR-12, BR-16, BR-18	DLN-87 (AWD)	TM-187 (AWD)	FAX-5 RAX-5	FSU-5 RSU-4	WT-61	WT-61	FAX-5 RAX-5 (AWD)	ST-28

x: Applicable

# BRAKE PEDAL

< BASIC INSPECTION >

## BASIC INSPECTION

### BRAKE PEDAL

Inspection

INFOID:000000012894311

#### BRAKE PEDAL HEIGHT

Check the brake pedal height (H) between the dash lower panel (2) and the brake pedal upper surface.

**CAUTION:**

**Check the brake pedal height with the floor trim removed.**

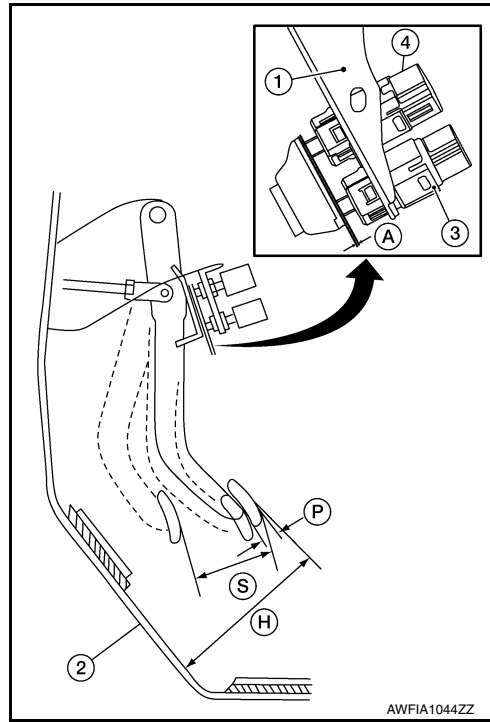

Brake pedal height (H) from dash lower panel (2)	Refer to <a href="#">BR-52, "Brake Pedal"</a> .
Clearance (A) between brake pedal bracket (1), stop lamp switch (3) and brake pedal position switch (4) contact ends	Refer to <a href="#">BR-52, "Brake Pedal"</a> .
Brake pedal full stroke (S)	Refer to <a href="#">BR-52, "Brake Pedal"</a> .
Brake pedal play (P)	Refer to <a href="#">BR-52, "Brake Pedal"</a> .

# BRAKE FLUID

< BASIC INSPECTION >

## BRAKE FLUID

### Inspection

INFOID:000000012894312

#### BRAKE FLUID LEVEL

- Make sure that the brake fluid level in the sub tank is between the MAX and MIN lines.
- Visually check around the sub tank and reservoir tank for brake fluid leakage.
- If the brake fluid level is excessively low, check the brake system for leakage.
- If brake warning lamp remains illuminated after parking brake pedal is released, check the brake system for brake fluid leakage.

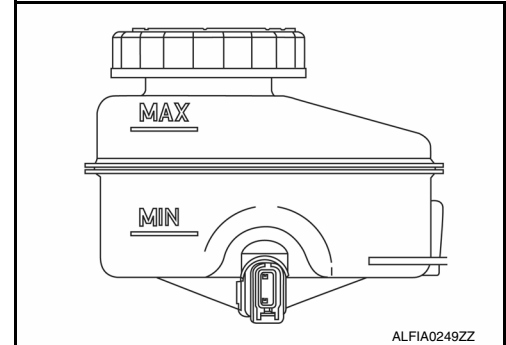

#### BRAKE LINE

1. Check brake line (tubes and hoses) for cracks, deterioration or other damage. Replace any damaged parts.
2. Check for brake fluid leakage by fully depressing brake pedal while engine is running.

**CAUTION:**

**If brake fluid leakage occurs around joints, retighten or replace damaged parts as necessary.**

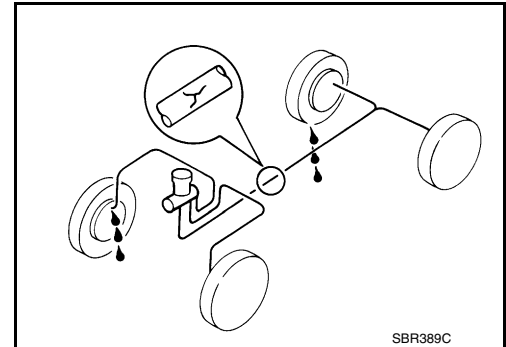



# BRAKE MASTER CYLINDER

< BASIC INSPECTION >

## BRAKE MASTER CYLINDER

---

### Inspection

INFOID:000000012894313

Check for brake fluid leakage at the following areas:

- Master cylinder mounting face
- Reservoir tank mounting face
- Sub tank mounting face
- Brake tube and brake tube connections
- Brake hose and brake hose connections

If any brake fluid leakage is found, repair as necessary.

A

B

C

D

E

**BR**

G

H

I

J

K

L

M

N

O

P

# BRAKE BOOSTER

< BASIC INSPECTION >

## BRAKE BOOSTER

### Inspection

INFOID:000000012894314

#### Operation

Depress the brake pedal several times at five second intervals with the engine stopped. Start the engine with the brake pedal fully depressed. Check that the clearance between brake pedal and dash lower panel decreases.

#### NOTE:

A slight impact with a small click may be felt on the pedal when the brake pedal is fully depressed. This is normal brake system operation.

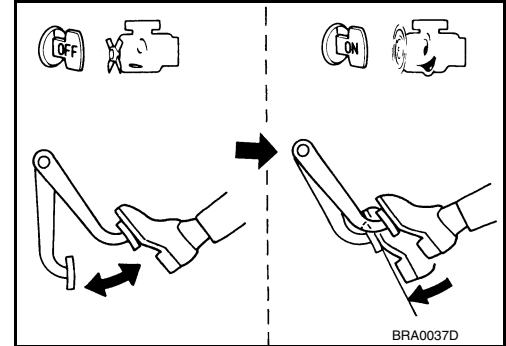

#### Vacuum Inspection

Idle the engine for one minute to apply vacuum to the brake booster. Stop the engine. Depress the brake pedal several times at five second intervals until the accumulated vacuum is released to atmospheric pressure. Check that the clearance between brake pedal and dash lower panel gradually increases (A → B → C) each time the brake pedal is depressed during this operation.

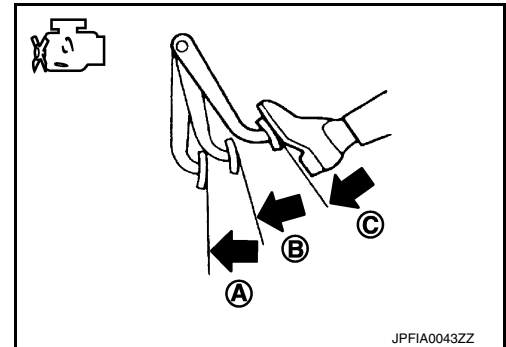

Depress the brake pedal with the engine running. Then stop the engine while holding down the brake pedal. Check that the brake pedal stroke does not change after holding down the brake pedal for 30 seconds or more.

#### NOTE:

A slight impact with a small click may be felt on the pedal when the brake pedal is fully depressed. This is normal brake system operation.

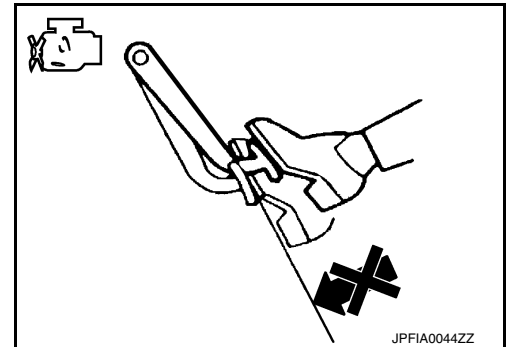

# FRONT DISC BRAKE

< BASIC INSPECTION >

## FRONT DISC BRAKE

### DISC BRAKE ROTOR

#### DISC BRAKE ROTOR : Inspection

INFOID:000000013381924

#### INSPECTION

##### Uneven Wear

Check for uneven wear of the disc brake rotor using a micrometer.  
Replace the disc brake rotor if the thickness is below the wear limit.

**Thickness variation** : Refer to [BR-53, "Front Disc Brake"](#).  
(measured at 8 positions)

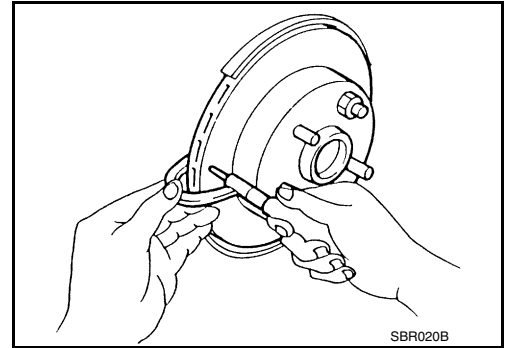

A

B

C

D

E

BR

G

H

I

J

K

L

M

N

O

P

# REAR DISC BRAKE

< BASIC INSPECTION >

## REAR DISC BRAKE

### DISC BRAKE ROTOR

#### DISC BRAKE ROTOR : Inspection

INFOID:000000013381928

#### INSPECTION

##### Uneven Wear

Check for uneven wear of the disc brake rotor using a micrometer.  
Replace the disc brake rotor if the thickness is below the wear limit.

**Thickness variation** : Refer to [BR-54, "Rear Disc Brake"](#).  
(measured at 8 positions)

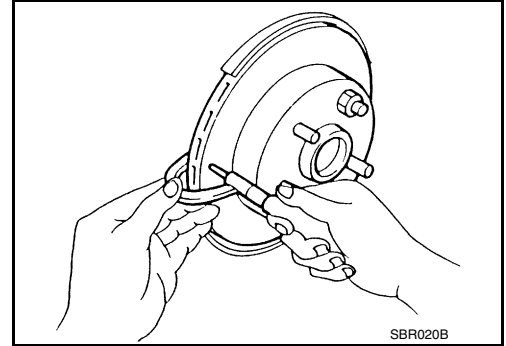

# BRAKE PEDAL

< PERIODIC MAINTENANCE >

## PERIODIC MAINTENANCE

### BRAKE PEDAL

#### Adjustment

INFOID:000000012894319

#### BRAKE PEDAL HEIGHT

1. Remove instrument lower panel LH. Refer to [IP-24, "Removal and Installation"](#).
2. Disconnect the harness connectors from the stop lamp switch and brake pedal position switch.
3. Turn the stop lamp switch and brake pedal position switch 45° counterclockwise.
4. Loosen the input rod lock nut (1).

**CAUTION:**

- Check the height with the floor trim removed.
- The threaded end of the input rod (2) must project to the inner side (L) of the clevis (3).

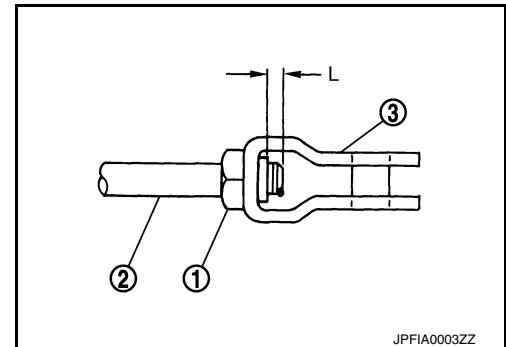

5. Adjust the brake pedal height to the specification. Refer to [BR-52, "Brake Pedal"](#).
6. Tighten the input rod lock nut to specification. Refer to [BR-32, "Exploded View"](#).
7. Turn the stop lamp switch and brake pedal position switch 45° clockwise.
8. Connect the harness connectors to the stop lamp switch and brake pedal position switch.
9. Check the brake pedal for smooth operation.

**CAUTION:**

**The stop lamp must turn off when the brake pedal is released.**

10. Install instrument lower panel LH. Refer to [IP-24, "Removal and Installation"](#).

#### STOP LAMP SWITCH AND BRAKE PEDAL POSITION SWITCH

1. Remove instrument lower panel LH. Refer to [IP-24, "Removal and Installation"](#).
2. Disconnect the harness connectors from the stop lamp switch and brake pedal position switch.
3. Turn the stop lamp switch and brake pedal position switch 45° counterclockwise.
4. With the threaded ends of the stop lamp switch (1) and brake pedal position switch (2) contacting the pedal bracket (3), turn the switches 45° clockwise to lock in place. Check that both the stop lamp switch (1) and brake pedal position switch (2) contact ends to brake pedal bracket (3) clearance (A) are within specification.

**CAUTION:**

- Make sure that the clearance (A) between the brake pedal bracket (3), stop lamp switch (1) and the brake pedal position switch (2) contact ends are within specification.
- The stop lamp must turn off when the brake pedal is released.

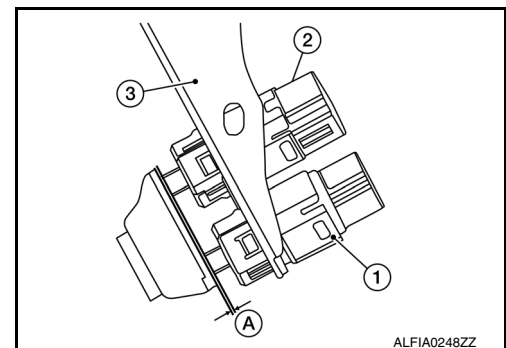

**Clearance (A) : Refer to [BR-52, "Brake Pedal"](#).**

5. Connect the harness connector to the stop lamp switch and the brake pedal position switch.
6. Install instrument lower panel LH. Refer to [IP-24, "Removal and Installation"](#).

# BRAKE FLUID

< PERIODIC MAINTENANCE >

## BRAKE FLUID

### Drain and Refill

INFOID:000000012894320

#### CAUTION:

- Do not spill or splash brake fluid on painted surfaces. Brake fluid may damage paint. If brake fluid is splashed on painted areas, wash it away with water immediately.
- Prior to repair, turn the ignition switch OFF, disconnect the harness connector from the ABS actuator and electric unit (control unit) or negative battery terminal. Refer to [PG-112, "Removal and Installation"](#).
- Refill brake system with new brake fluid. Refer to [MA-12, "Fluids and Lubricants"](#).
- Do not reuse drained brake fluid.

### DRAINING

1. Turn ignition switch OFF and disconnect the harness connector from the ABS actuator and electric unit (control unit) or negative battery terminal. Refer to [PG-112, "Removal and Installation"](#).
2. Connect a vinyl tube to bleeder valve.
3. Depress brake pedal, loosen bleeder valve, and gradually remove brake fluid.

#### CAUTION:

Do not allow reservoir tank to empty as this may cause damage to master cylinder internal components.

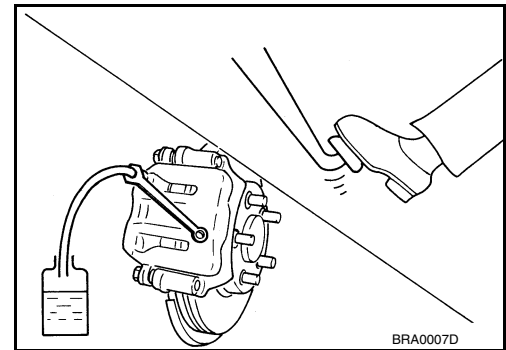

### REFILLING

1. Make sure no foreign material is in the reservoir tank or sub tank, and refill with new brake fluid.

#### CAUTION:

Do not reuse drained brake fluid.

2. Refill the brake system as follows:
  - Depress the brake pedal.
  - Loosen bleeder valve.
  - Slowly depress brake pedal to 2/3 of the brake pedal full stroke.
  - Tighten bleeder valve.
  - Release brake pedal.

Repeat this operation at intervals of two or three seconds until all old brake fluid is discharged. Add new brake fluid to sub tank frequently.

#### CAUTION:

Do not allow reservoir tank to empty as this may cause damage to master cylinder internal components.

3. Bleed the air out of the brake hydraulic system. Refer to [BR-14, "Bleeding Brake System"](#).

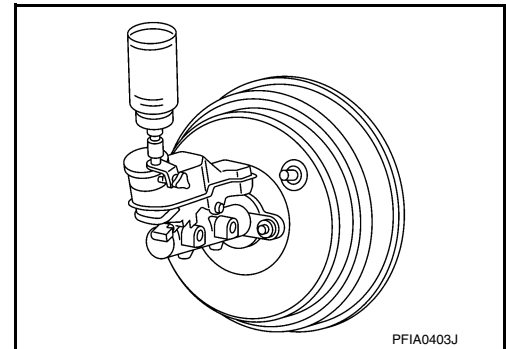

### Bleeding Brake System

INFOID:000000012894321

#### CAUTION:

- While bleeding, pay attention to brake fluid level.
- Do not allow reservoir tank to empty as this may cause damage to master cylinder internal components.
- Before working, disconnect the harness connector from the ABS actuator and electric unit (control unit) or negative battery terminal. Refer to [PG-112, "Removal and Installation"](#).

1. Turn ignition switch OFF and disconnect the harness connector from the ABS actuator and electric unit (control unit) or negative battery terminal. Refer to [PG-112, "Removal and Installation"](#).
2. Connect a vinyl tube to front (RH) brake caliper bleeder valve.
3. Fully depress brake pedal 4 or 5 times.

## BRAKE FLUID

### < PERIODIC MAINTENANCE >

---

4. With brake pedal depressed, loosen bleeder valve to bleed air in brake line, and then tighten it immediately.
5. Repeat steps 3 and 4 until all of the air is out of the brake line.
6. Tighten the bleeder valve to the specified torque. Refer to [BR-46. "Exploded View"](#) (front disc brake), [BR-49. "Exploded View"](#) (rear disc brake).
7. Repeat steps 2 through 6, with sub tank filled at least halfway. Bleed the air in the following order from the front (RH), front (LH), rear (RH), rear (LH).

A

B

C

D

E

BR

G

H

I

J

K

L

M

N

O

P

# FRONT DISC BRAKE

< PERIODIC MAINTENANCE >

## FRONT DISC BRAKE BRAKE PAD

### BRAKE PAD : Inspection

INFOID:000000013380833

Check brake pad wear thickness from an inspection hole (A) on cylinder body. Check using a scale if necessary.

**Wear thickness** : Refer to [BR-53, "Front Disc Brake"](#).

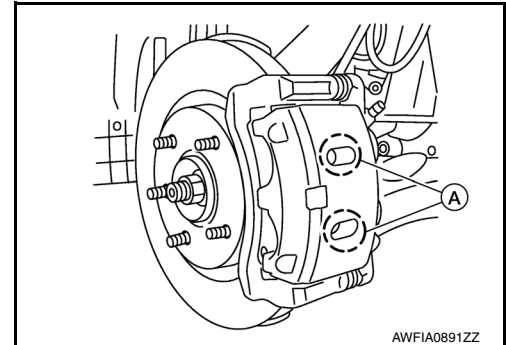

### BRAKE PAD : Brake Burnishing

INFOID:000000013380996

#### **CAUTION:**

- **Burnish contact surfaces between brake pads and disc brake rotor according to the following procedure after refinishing the disc brake rotor, replacing brake pads or if a soft pedal occurs at very low mileage.**
  - **Be careful of vehicle speed. Brakes do not operate firmly/securely until pads and disc brake rotor are securely seated.**
  - **Only perform this procedure under safe road and traffic conditions. Use extreme caution.**
1. Drive the vehicle on straight, flat road.
  2. Depress the brake pedal until the vehicle stops.
  3. Release the brake pedal for a few minutes to allow the brake components to cool.
  4. Repeat steps 1 to 3 until pad and disc brake rotor are securely seated.

## DISC BRAKE ROTOR

### DISC BRAKE ROTOR : Inspection

INFOID:000000013380834

#### APPEARANCE

Check surface of disc brake rotor for uneven wear, cracks or damage. Replace if any abnormal conditions exist.

#### RUNOUT

1. Check the wheel bearing axial end play before the inspection. Refer to [FAX-6, "Inspection"](#).
2. Secure the disc brake rotor to the wheel hub and bearing with wheel nuts at two wheel nut locations.
3. Measure the runout using a dial gauge 10 mm (0.39 in) from the disc brake rotor edge.

**Runout (with it attached to the vehicle)** : Refer to [BR-53, "Front Disc Brake"](#).

4. Find the installation position with a minimum runout by shifting the disc brake rotor-to-wheel hub and bearing installation position by one hole at a time if the runout exceeds the limit value.
5. Refinish the disc brake rotor if the runout is outside the limit even after performing the above operation. When refinishing, use Tool.

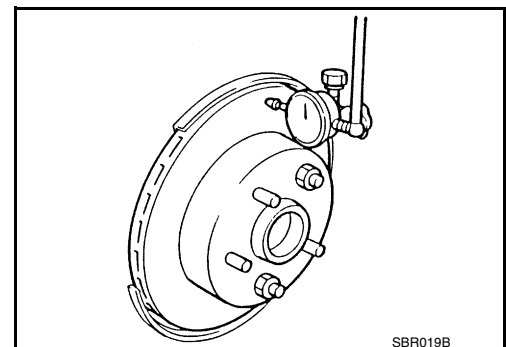

**Tool number** : 38-PFM92 ( — )

#### **CAUTION:**



# FRONT DISC BRAKE

## < PERIODIC MAINTENANCE >

- Check in advance that the thickness of the disc brake rotor is wear thickness + 0.3 mm (0.012 in) or more.
- If the thickness is less than wear thickness + 0.3 mm (0.012 in), replace the disc brake rotor. Refer to [BR-40, "DISC BRAKE ROTOR : Removal and Installation"](#).

**Wear thickness** : Refer to [BR-53, "Front Disc Brake"](#).

### THICKNESS

Check the thickness of the disc brake rotor using a micrometer. Replace the disc brake rotor if the thickness is below the wear limit.

**Wear thickness** : Refer to [BR-53, "Front Disc Brake"](#).

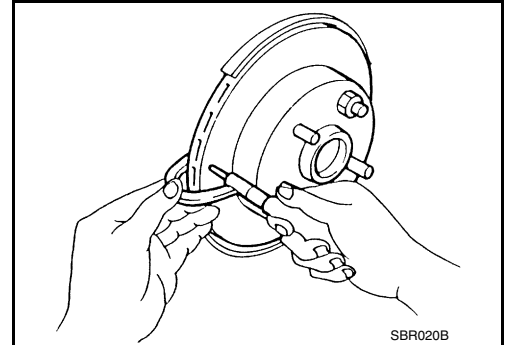

### DISC BRAKE ROTOR : Brake Burnishing

INFOID:000000013380939

#### CAUTION:

- Burnish contact surfaces between brake pads and disc brake rotor according to the following procedure after refinishing the disc brake rotor, replacing brake pads or if a soft pedal occurs at very low mileage.
  - Be careful of vehicle speed. Brakes do not operate firmly/securely until pads and disc brake rotor are securely seated.
  - Only perform this procedure under safe road and traffic conditions. Use extreme caution.
1. Drive the vehicle on straight, flat road.
  2. Depress the brake pedal until the vehicle stops.
  3. Release the brake pedal for a few minutes to allow the brake components to cool.
  4. Repeat steps 1 to 3 until pad and disc brake rotor are securely seated.

# REAR DISC BRAKE

< PERIODIC MAINTENANCE >

## REAR DISC BRAKE BRAKE PAD

### BRAKE PAD : Inspection

INFOID:000000013381096

#### INSPECTION

Check brake pad wear thickness from an inspection hole (A) on cylinder body. Check using a scale if necessary.

**Wear thickness** : Refer to [BR-54, "Rear Disc Brake"](#).

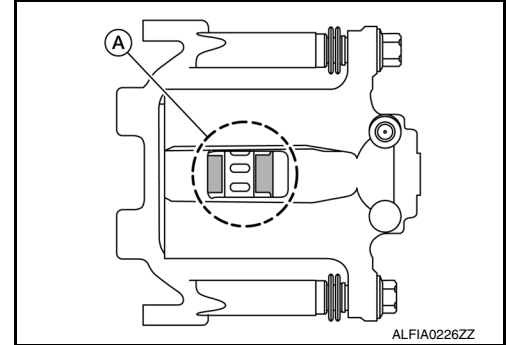

### BRAKE PAD : Brake Burnishing

INFOID:000000013381140

#### CAUTION:

- **Burnish contact surfaces between brake pads and disc brake rotor according to the following procedure after refinishing the disc brake rotor, replacing brake pads or if a soft pedal occurs at very low mileage.**
  - **Be careful of vehicle speed. Brakes do not operate firmly/securely until pads and disc brake rotor are securely seated.**
  - **Only perform this procedure under safe road and traffic conditions. Use extreme caution.**
1. Drive the vehicle on straight, flat road.
  2. Depress the brake pedal until the vehicle stops.
  3. Release the brake pedal for a few minutes to allow the brake components to cool.
  4. Repeat steps 1 to 3 until pad and disc brake rotor are securely seated.

## DISC BRAKE ROTOR

### DISC BRAKE ROTOR : Inspection

INFOID:000000013381105

#### APPEARANCE

Check surface of disc brake rotor for uneven wear, cracks or damage. Replace if any abnormal conditions exist.

#### RUNOUT

1. Check the wheel bearing axial end play before the inspection. Refer to [RAX-6, "Inspection"](#).
2. Secure the disc brake rotor to the wheel hub and bearing with wheel nuts at two wheel nut locations.
3. Measure the runout using a dial gauge 10 mm (0.39 in) from the disc brake rotor edge.

**Runout (with it attached to the vehicle)** : Refer to [BR-54, "Rear Disc Brake"](#).

4. Find the installation position with a minimum runout by shifting the disc brake rotor-to-wheel hub and bearing installation position by one hole at a time if the runout exceeds the limit value.
5. Refinish the disc brake rotor if the runout is outside the limit even after performing the above operation. When refinishing, use Tool.

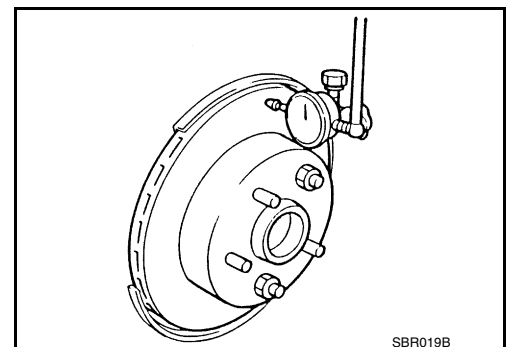

**Tool number** : 38-PFM92 ( — )

# REAR DISC BRAKE

## < PERIODIC MAINTENANCE >

### CAUTION:

- Check in advance that the thickness of the disc brake rotor is wear thickness + 0.3 mm (0.012 in) or more.
- If the thickness is less than wear thickness + 0.3 mm (0.012 in), replace the disc brake rotor. Refer to [BR-45, "DISC BRAKE ROTOR : Removal and Installation"](#).

**Wear thickness** : Refer to [BR-54, "Rear Disc Brake"](#).

### THICKNESS

Check the thickness of the disc brake rotor using a micrometer. Replace the disc brake rotor if the thickness is below the minimum thickness.

**Wear thickness** : Refer to [BR-54, "Rear Disc Brake"](#)

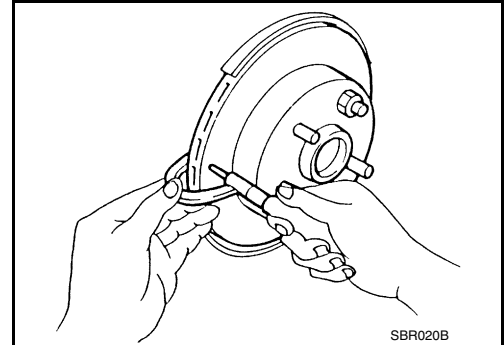

## DISC BRAKE ROTOR : Brake Burnishing

INFOID:000000013381110

### CAUTION:

- Burnish contact surfaces between brake pads and disc brake rotor according to the following procedure after refinishing the disc brake rotor, replacing brake pads or if a soft pedal occurs at very low mileage.
  - Be careful of vehicle speed. Brakes do not operate firmly/securely until pads and disc brake rotor are securely seated.
  - Only perform this procedure under safe road and traffic conditions. Use extreme caution.
1. Drive the vehicle on straight, flat road.
  2. Depress the brake pedal until the vehicle stops.
  3. Release the brake pedal for a few minutes to allow the brake components to cool.
  4. Repeat steps 1 to 3 until pad and disc brake rotor are securely seated.

# BRAKE PEDAL

< REMOVAL AND INSTALLATION >

## REMOVAL AND INSTALLATION

### BRAKE PEDAL

Exploded View

INFOID:000000012894324

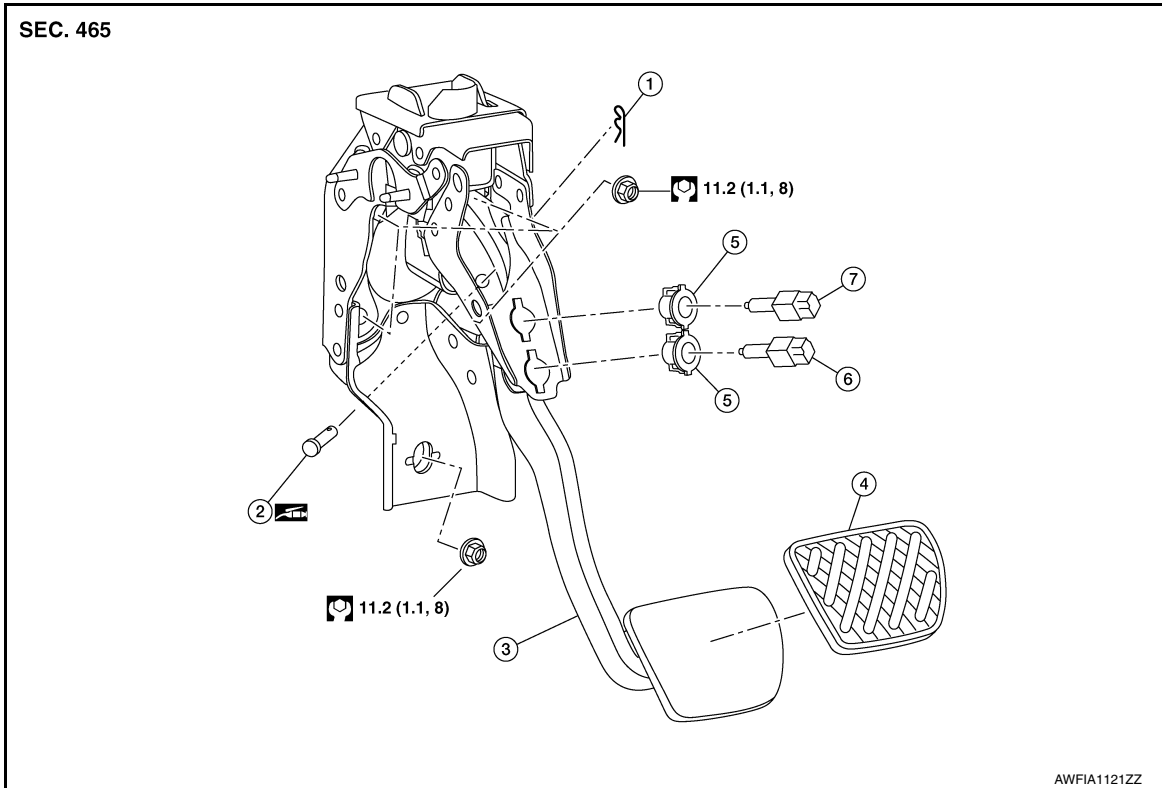

- |                                |               |                         |
|--------------------------------|---------------|-------------------------|
| 1. Snap pin                    | 2. Clevis pin | 3. Brake pedal assembly |
| 4. Brake pedal pad             | 5. Clip       | 6. Stop lamp switch     |
| 7. Brake pedal position switch |               |                         |

### Removal and Installation

INFOID:000000012894325

#### REMOVAL

1. Remove instrument lower panel LH. Refer to [IP-24, "Removal and Installation"](#).
2. Remove the lower nut from the brake pedal assembly.
3. Disconnect the harness connectors from the stop lamp switch and brake pedal position switch.
4. Remove wire harness clips from brake pedal assembly.
5. Remove snap pin (1) and clevis pin (2) from the brake pedal assembly.

**CAUTION:**

**Do not reuse the snap pin or clevis pin**

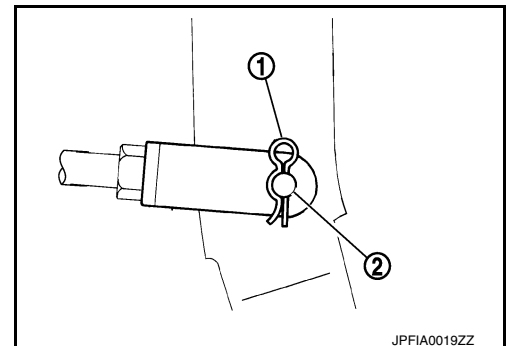

JPFIA0019ZZ

6. Remove the remaining nuts from the brake pedal and remove the brake pedal.

**CAUTION:**

# BRAKE PEDAL

## < REMOVAL AND INSTALLATION >

**Support the brake booster and master cylinder to prevent contact with other components.**

### INSPECTION AFTER REMOVAL

- Check the following items and replace the brake pedal assembly if necessary.
- Check the brake pedal upper rivet (made of aluminum) (A) for deformation.
- Check the brake pedal for bend, damage, and cracks on the welded parts.
- Check the overlap distance (X) between sub-bracket (B) and slide plate (C).

**Overlap distance (X) : Refer to [BR-52, "Brake Pedal"](#).  
between sub-bracket (B) and slide plate (C).**

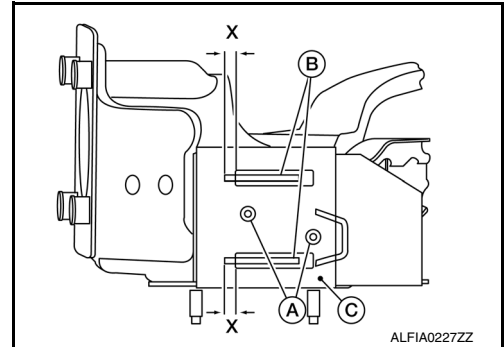

### INSTALLATION

Installation is in the reverse order of removal.

- Inspect the brake pedal height after installing the brake pedal to the vehicle. Adjust if necessary refer to [BR-7, "Inspection"](#).

#### **CAUTION:**

**Replace the brake pedal if it has been dropped or sustained an impact.**

# BRAKE PIPING

< REMOVAL AND INSTALLATION >

## BRAKE PIPING

### FRONT

#### FRONT : Exploded View

INFOID:000000012894326

WITHOUT ICC

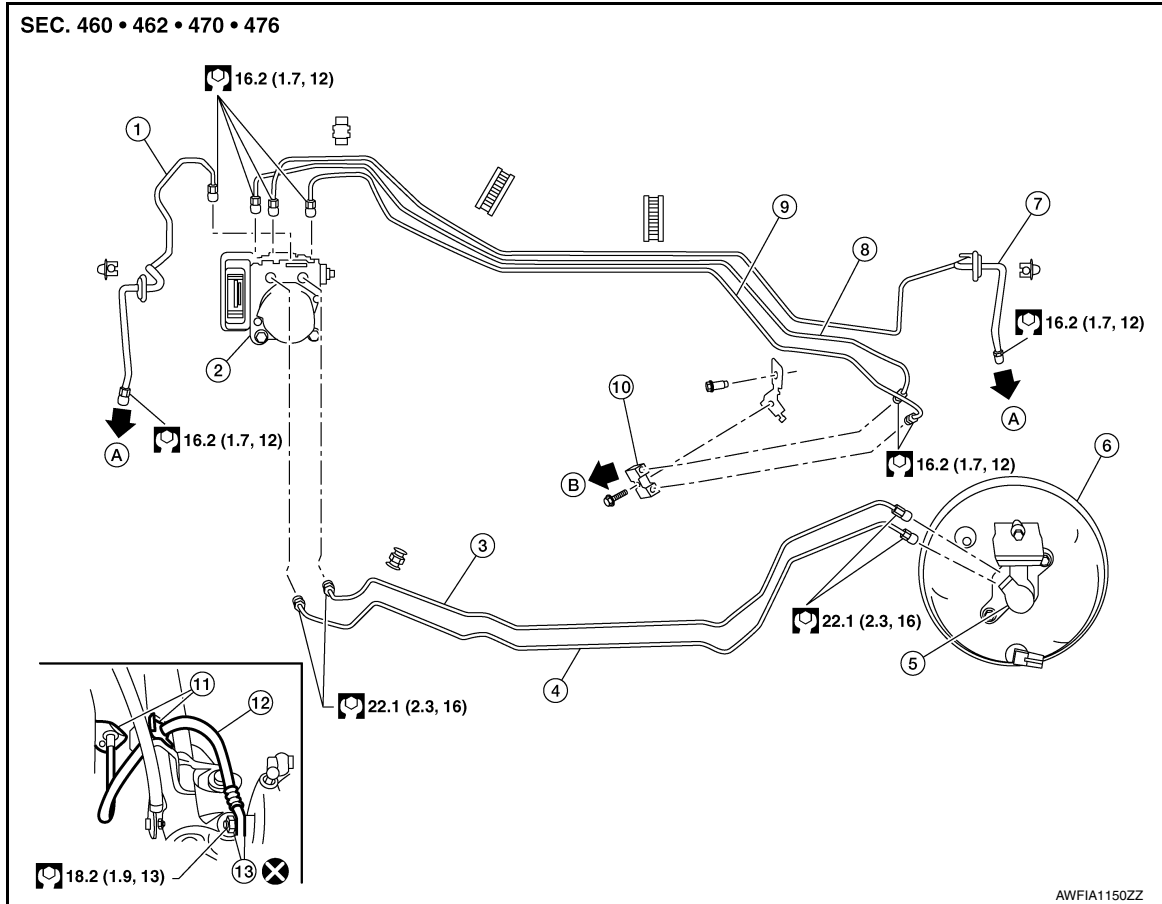

- |   |  |   |
|---|--|---|
| 1. Brake tube (RH)                                      | 2. ABS actuator and electric unit (control unit) | 3. Master cylinder primary to ABS actuator brake tube |
| 4. Master cylinder secondary to ABS actuator brake tube | 5. Master cylinder                               | 6. Brake booster                                      |
| 7. Brake tube (LH)                                      | 8. ABS actuator to connector brake tube (RH)     | 9. ABS actuator to connector brake tube (LH)          |
| 10. Connector   | 11. Lock plates                                  | 12. Front brake hose                                  |
| 13. Copper sealing washers                              | A. To front brake hose                           | B. To rear brake pipe                                 |

# BRAKE PIPING

< REMOVAL AND INSTALLATION >

WITH ICC

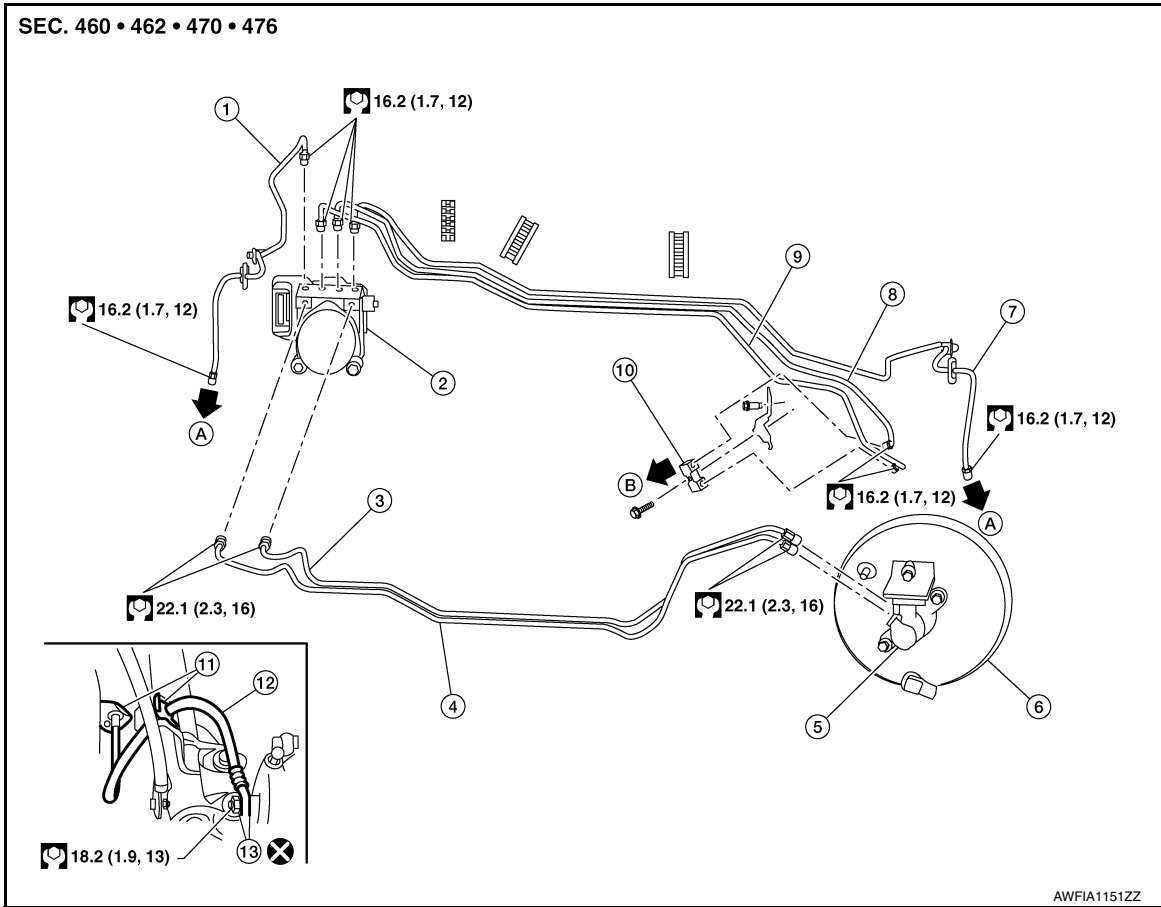

- |   |  |   |
|---|--|---|
| 1. Brake tube (RH)                                      | 2. ABS actuator and electric unit (control unit) | 3. Master cylinder primary to ABS actuator brake tube |
| 4. Master cylinder secondary to ABS actuator brake tube | 5. Master cylinder                               | 6. Brake booster                                      |
| 7. Brake tube (LH)                                      | 8. ABS actuator to connector brake tube (RH)     | 9. ABS actuator to connector brake tube (LH)          |
| 10. Connector   | 11. Lock plates                                  | 12. Front brake hose                                  |
| 13. Copper sealing washers                              | A. To front brake hose                           | B. To rear brake pipe                                 |

# BRAKE PIPING

< REMOVAL AND INSTALLATION >

## FRONT : Hydraulic Piping

INFOID:000000012894327

### WITHOUT ICC

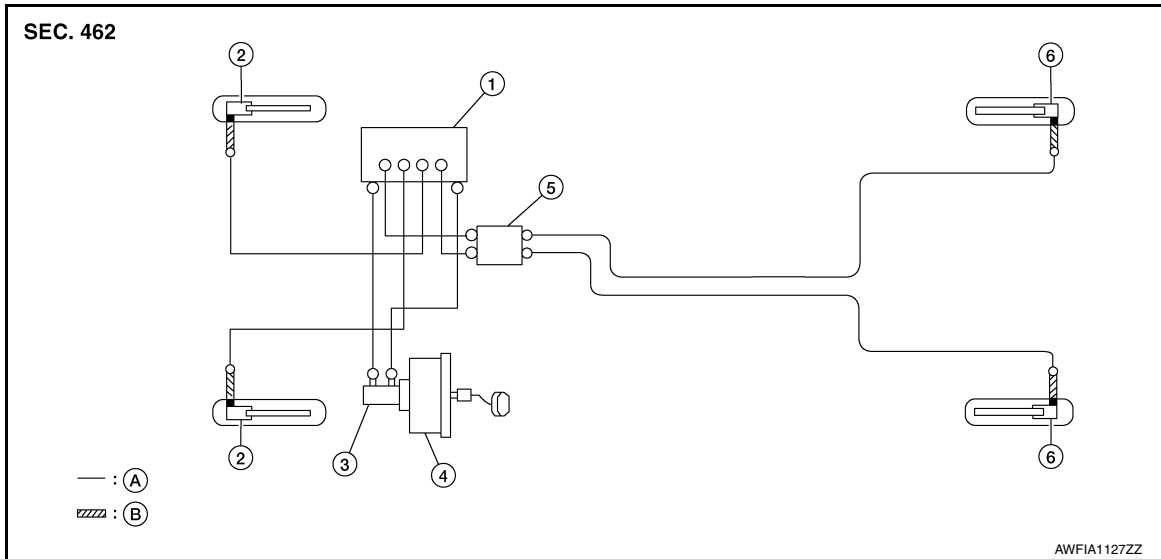

- |  |                     |                             |
|--|---------------------|-----------------------------|
| 1. ABS actuator and electric unit (control unit) | 2. Front disc brake | 3. Master cylinder assembly |
| 4. Brake booster                                 | 5. Connector        | 6. Rear disc brake          |
| A. Brake tube                                    | B. Brake hose       |                             |

○: Flare nut

■: Union bolt

### WITH ICC

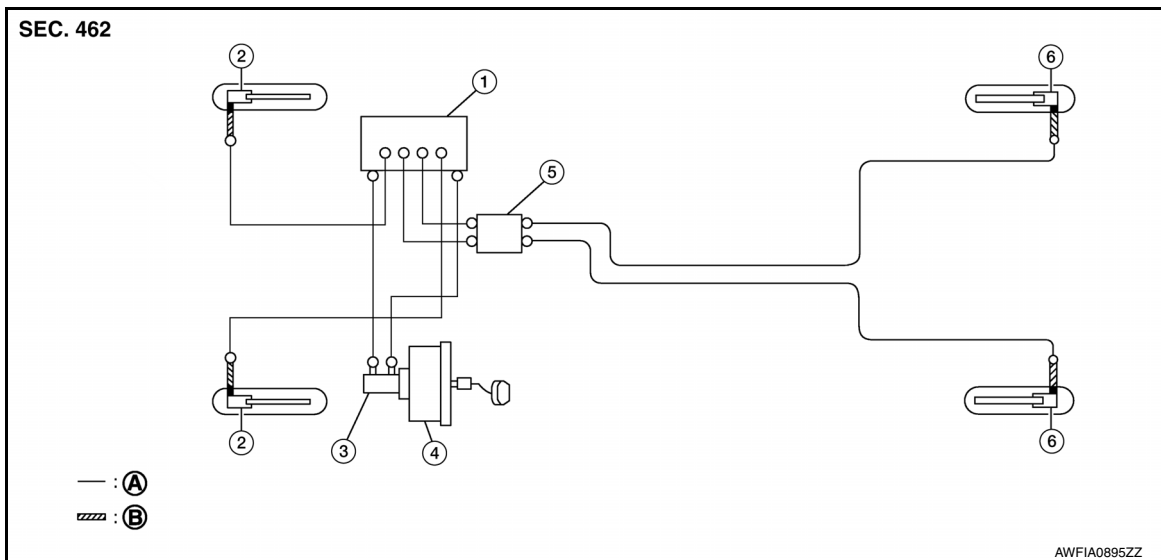

- |  |                     |                             |
|--|---------------------|-----------------------------|
| 1. ABS actuator and electric unit (control unit) | 2. Front disc brake | 3. Master cylinder assembly |
| 4. Brake booster                                 | 5. Connector        | 6. Rear disc brake          |
| A. Brake tube                                    | B. Brake hose       |                             |

○: Flare nut

■: Union bolt

## FRONT : Removal and Installation

INFOID:000000012894328

**CAUTION:**



# BRAKE PIPING

## < REMOVAL AND INSTALLATION >

- All hoses and piping (tubes) must be free from excessive bending, twisting and pulling.
- Make sure there is no interference with other parts when turning steering both clockwise and counterclockwise.
- Do not spill or splash brake fluid on painted surfaces. Brake fluid may seriously damage paint. Wipe it off immediately and wash with water if it gets on a painted surface.
- Do not allow foreign matter (e.g. dust) and oils other than brake fluid to enter the reservoir tank.

### NOTE:

When removing components such as hoses, tubes/lines, etc., cap or plug openings to prevent fluid from spilling.

### REMOVAL

1. Remove sub tank cap.
2. Remove wheels and tires using power tool.
3. Loosen the flare nut with a flare nut wrench and separate the brake tube from the hose.

#### CAUTION:

- Do not scratch the flare nut and the brake pipe.
- All brake hoses and pipes must be free from excessive bending, twisting and pulling.

4. Remove the union bolt (A) and the brake hose from the brake caliper. Remove and discard the copper sealing washers (1).

#### CAUTION:

Do not reuse copper sealing washers.

5. Remove the lock plates and remove the brake hose.

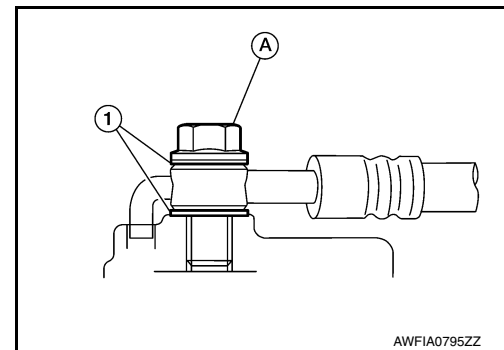

### INSTALLATION

#### CAUTION:

Do not allow foreign matter (e.g. dust) and oils other than brake fluid to enter the sub tank and reservoir tank.

1. Assemble the union bolt (A) and the copper sealing washers (1) to the brake hose and install it as an assembly to the brake caliper. Align the brake hose L-pin by aligning it with the brake caliper hole, and tighten the union bolt (1) to the specified torque.

#### CAUTION:

Do not reuse copper sealing washers.

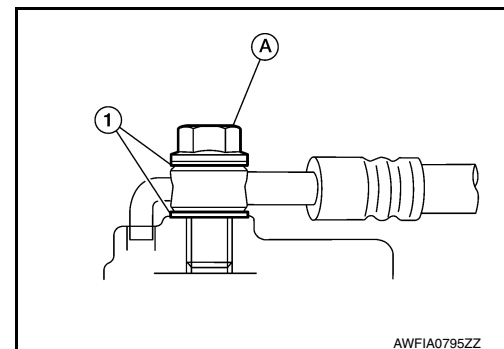

2. Install the brake pipe to the brake hose, temporarily tighten the flare nut by hand until it does not rotate further, and attach the brake hose to the bracket with the lock plates.

#### CAUTION:

Check that the brake hoses and pipes are not bent or twisted.

3. Tighten the flare nut to the specified torque with a flare nut crowfoot and a torque wrench.

#### CAUTION:

Do not scratch the flare nut and the brake pipe.

4. Refill with new brake fluid and perform the air bleeding. Refer to [BR-14, "Bleeding Brake System"](#).

#### CAUTION:

Do not reuse drained brake fluid.

5. Install the wheels and tires. Refer to [WT-66, "Removal and Installation"](#).

6. Perform inspection after installation. Refer to [BR-8, "Inspection"](#).

### REAR

# BRAKE PIPING

< REMOVAL AND INSTALLATION >

REAR : Exploded View

INFOID:000000012894329

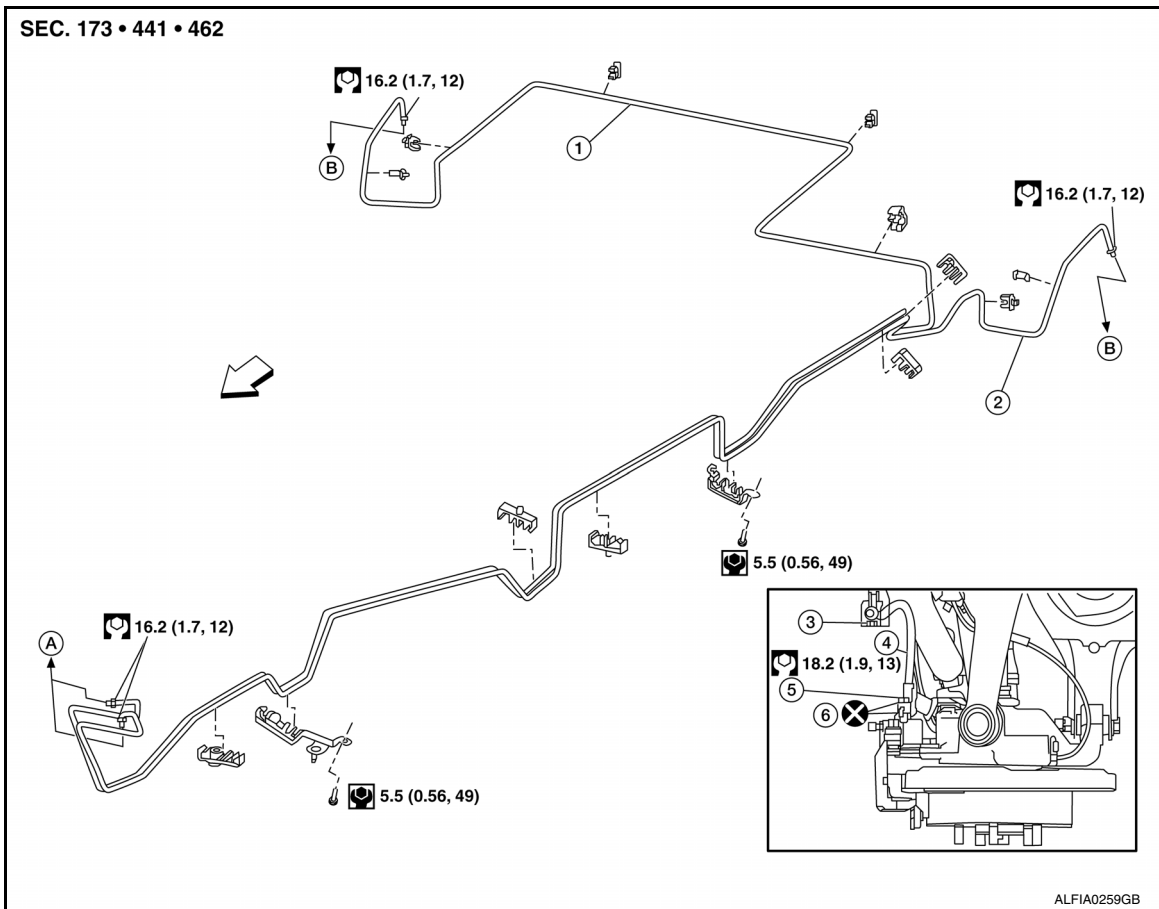

- |                                  |                                  |                           |
|----------------------------------|----------------------------------|---------------------------|
| 1. Rear brake pipe assembly - RH | 2. Rear brake pipe assembly - LH | 3. Lock plate             |
| 4. Rear brake hose               | 5. Union bolt                    | 6. Copper sealing washers |
| A. To brake pipe connector       | B. To rear brake hose            | ⇐ Front                   |

REAR : Hydraulic Piping

INFOID:000000012894330

WITHOUT ICC

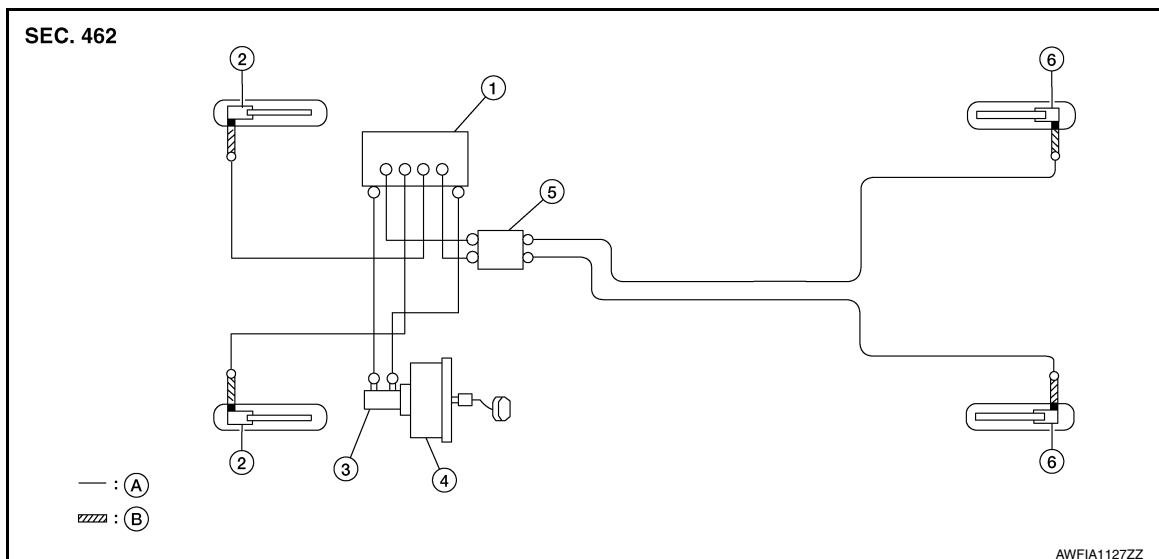

# BRAKE PIPING

## < REMOVAL AND INSTALLATION >

- |  |                     |                             |
|--|---------------------|-----------------------------|
| 1. ABS actuator and electric unit (control unit) | 2. Front disc brake | 3. Master cylinder assembly |
| 4. Brake booster                                 | 5. Connector        | 6. Rear disc brake          |
| A. Brake tube                                    | B. Brake hose       |                             |

- : Flare nut  
 ■ : Union bolt

WITH ICC

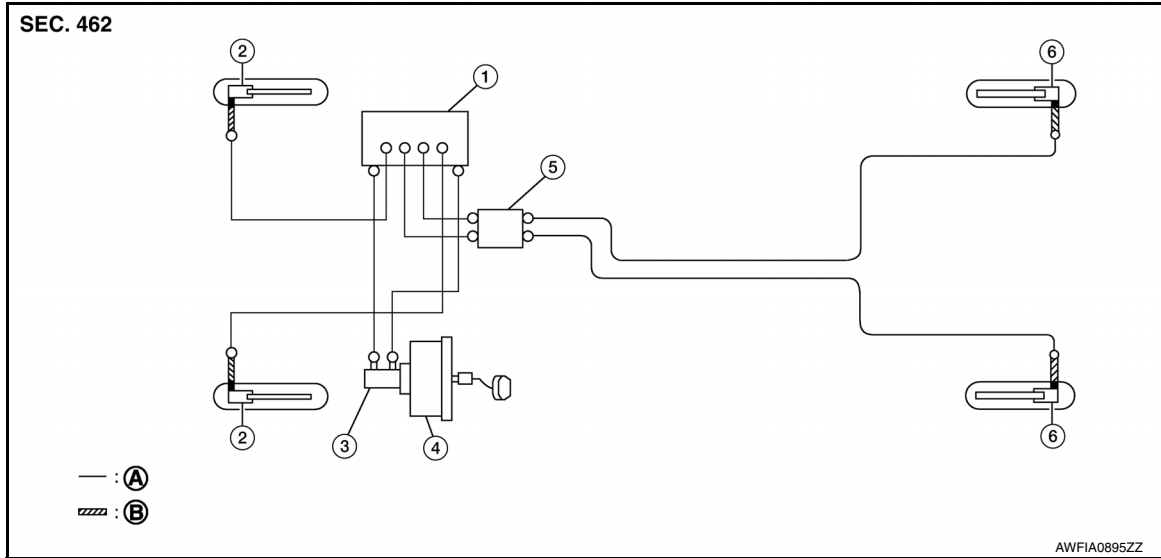

- |  |                     |                             |
|--|---------------------|-----------------------------|
| 1. ABS actuator and electric unit (control unit) | 2. Front disc brake | 3. Master cylinder assembly |
| 4. Brake booster                                 | 5. Connector        | 6. Rear disc brake          |
| A. Brake tube                                    | B. Brake hose       |                             |

- : Flare nut  
 ■ : Union bolt

## REAR : Removal and Installation

INFOID:000000012894331

### CAUTION:

- All hoses and piping (tubes) must be free from excessive bending, twisting and pulling.
- The brake piping is an important safety part. If a brake fluid leak is detected, always disassemble the parts. Replace applicable part with a new one, if necessary.
- Do not spill or splash brake fluid on painted surfaces. Brake fluid may seriously damage paint. Wipe it off immediately and wash with water if it gets on a painted surface.
- Do not allow foreign matter (e.g. dust) and oils other than brake fluid to enter the reservoir tank.

### NOTE:

When removing components such as hoses, tubes/lines, etc., cap or plug openings to prevent fluid from spilling.

### REMOVAL

1. Remove sub tank cap.
2. Remove wheels and tires using power tool.
3. Loosen the flare nut with a flare nut wrench and separate the brake tube from the hose.

### CAUTION:

- Do not scratch the flare nut and the brake pipe.
- All brake hoses and pipes must be free from excessive bending, twisting and pulling.

## BRAKE PIPING

### < REMOVAL AND INSTALLATION >

4. Remove the union bolt (A) and the brake hose from the brake caliper. Remove and discard the copper sealing washers (1).  
**CAUTION:**  
**Do not reuse copper sealing washers.**
5. Remove the lock plate and remove the brake hose.

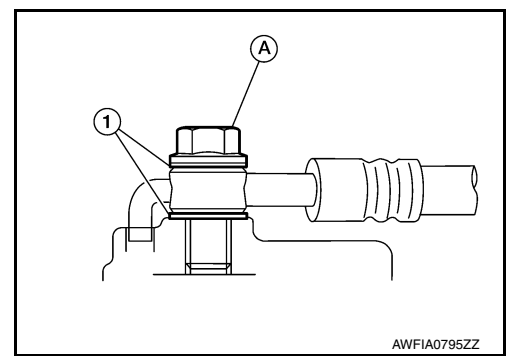

### INSTALLATION

#### **CAUTION:**

**Do not allow foreign matter (e.g. dust) and oils other than brake fluid to enter the sub tank and reservoir tank.**

1. Assemble the union bolt (A) and the copper sealing washers (1) to the brake hose and install it as an assembly to the brake caliper. Align the brake hose L-pin by aligning it with the brake caliper hole, and tighten the union bolt (1) to the specified torque.

#### **CAUTION:**

**Do not reuse copper sealing washers.**

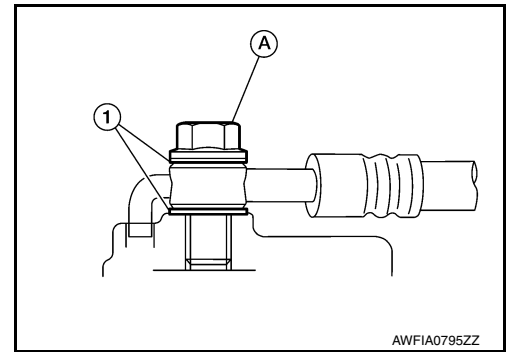

2. Install the brake pipe to the brake hose, temporarily tighten the flare nut by hand until it does not rotate further, and attach the brake hose to the bracket with the lock plate.  
**CAUTION:**  
**Check that the brake hoses and pipes are not bent or twisted.**
3. Tighten the flare nut to the specified torque with a flare nut crowfoot and a torque wrench.  
**CAUTION:**  
**Do not scratch the flare nut and the brake pipe.**
4. Refill with new brake fluid and perform the air bleeding. Refer to [BR-14, "Bleeding Brake System"](#).  
**CAUTION:**  
**Do not reuse drained brake fluid.**
5. Install the wheels and tires. Refer to [WT-66, "Removal and Installation"](#).
6. Perform inspection after installation. Refer to [BR-8, "Inspection"](#).

# BRAKE MASTER CYLINDER

< REMOVAL AND INSTALLATION >

## BRAKE MASTER CYLINDER

Exploded View

INFOID:000000012894332

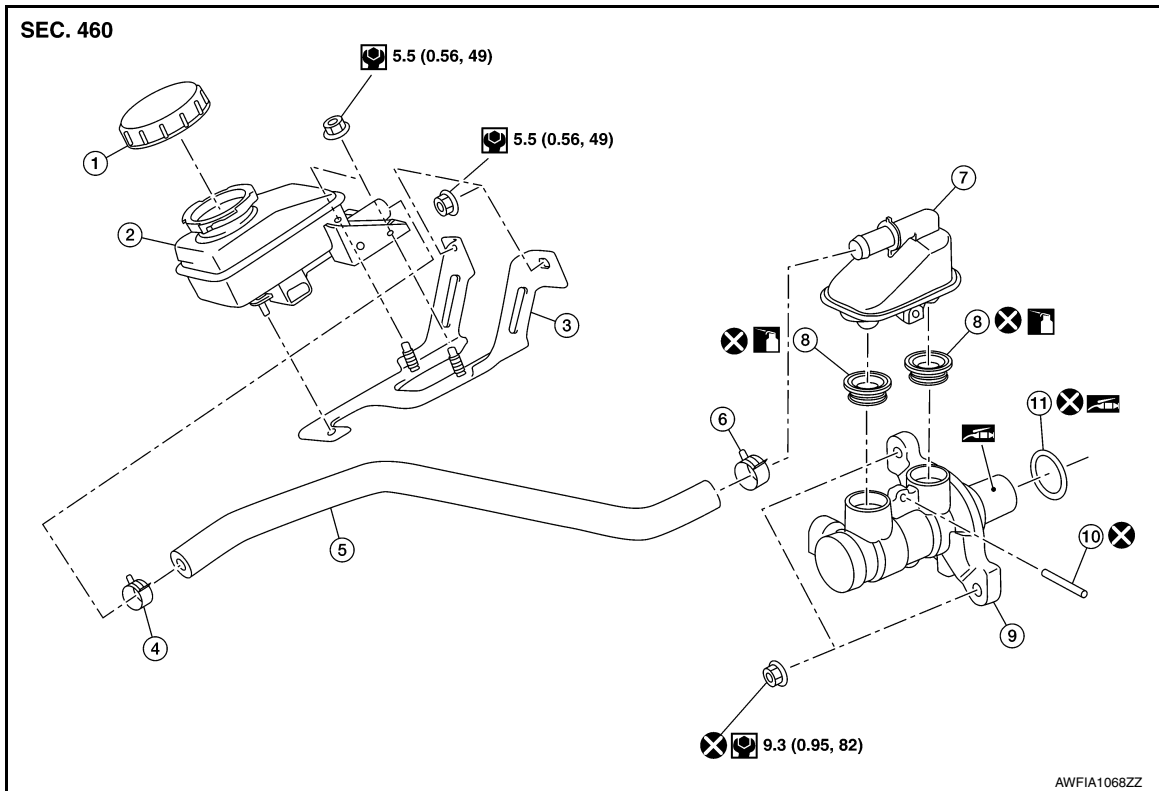

- |                   |             |                     |
|-------------------|-------------|---------------------|
| 1. Sub tank cap   | 2. Sub tank | 3. Sub tank bracket |
| 4. Clamp          | 5. Hose     | 6. Clamp            |
| 7. Reservoir tank | 8. Grommet  | 9. Cylinder body    |
| 10. Pin           | 11. O-ring  |                     |

 Apply PBC (Poly Butyl Cuprysil) grease or silicone-based grease.

 Apply brake fluid.

### Removal and Installation

INFOID:000000012894333

#### CAUTION:

- Do not spill or splash brake fluid on painted areas; it may cause paint damage. If brake fluid is splashed on painted areas, wash it away with water immediately.
- Do not reuse drained brake fluid.

#### NOTE:

When removing components such as hoses, tubes/lines, etc., cap or plug openings to prevent fluid from spilling.

#### REMOVAL

1. Remove sub tank cap.

# BRAKE MASTER CYLINDER

## < REMOVAL AND INSTALLATION >

2. Remove the sub tank bracket nuts (A), release the brake fluid level switch harness clips (B) and position the sub tank assembly (1) aside.

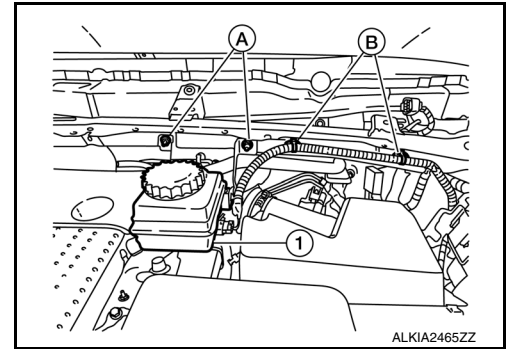

3. Remove air cleaner case as an assembly. Refer to [EM-26. "Removal and Installation"](#).
4. Disconnect the brake pipes from the master cylinder assembly with a flare nut wrench.  
**CAUTION:**  
**Do not scratch the flare nut or the brake pipe.**
5. Remove the master cylinder assembly.  
**CAUTION:**  
**Do not depress the brake pedal after the master cylinder assembly is removed.**

## INSTALLATION

Installation is in the reverse order of removal.

### **CAUTION:**

- Do not spill or splash brake fluid on painted areas; it may cause paint damage. If brake fluid is splashed on painted areas, wash it away with water immediately.
- Do not reuse master cylinder assembly nuts.
- Do not reuse O-ring.
- Apply PBC (Poly Butyl Cuprysil) silicone-based grease to the brake booster (A) when installing the master cylinder assembly to the brake booster.
- Temporarily tighten the brake tube flare nut to the master cylinder assembly by hand. Then tighten it to the specified torque with a flare nut crowfoot and torque wrench. Refer to [BR-22. "FRONT : Exploded View"](#).

### **CAUTION:**

- Do not scratch the flare nut or the brake pipe.
- After installation, perform the air bleeding. Refer to [BR-14. "Bleeding Brake System"](#).

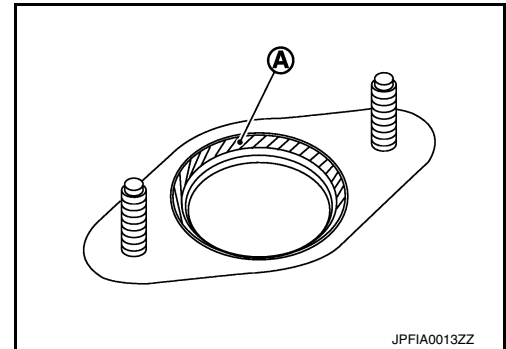

## Disassembly and Assembly

INFOID:0000000012894334

## DISASSEMBLY

### **CAUTION:**

- Do not disassemble the cylinder body.
- Remove the reservoir tank only when necessary.
- Do not drop removed parts. The parts must not be reused if they are dropped.

1. Secure the master cylinder assembly in a vise.

### **CAUTION:**

**Always use copper plates or cloth between vise and cylinder body. Do not overtighten the vise.**

## BRAKE MASTER CYLINDER

### < REMOVAL AND INSTALLATION >

- Remove the reservoir tank pin using suitable tools.  
**CAUTION:**  
**Do not reuse the pin.**
- Remove the reservoir tank and grommets from the cylinder body. Discard the grommets.  
**CAUTION:**
  - Do not drop parts. Dropped parts must not be reused.
  - Do not reuse the grommets.

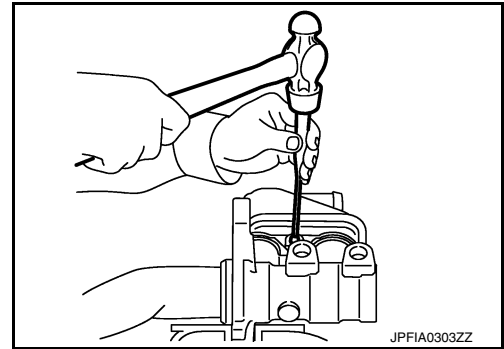

### ASSEMBLY

- Apply new brake fluid to the grommets and install them to the cylinder body.  
**CAUTION:**  
**Do not use mineral oil such as gasoline or light oil.**
- Install the reservoir tank to the cylinder body.  
**CAUTION:**  
**Do not drop the parts during installation. The parts must not be reused if they are dropped.**
- Tilt the reservoir tank so that the pin can be inserted. Insert a pin using suitable tools.  
**CAUTION:**  
**Do not reuse the pin.**

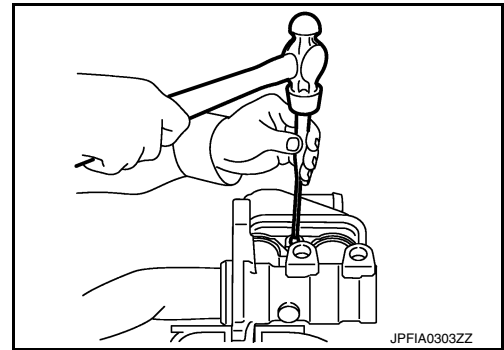

A  
B  
C  
D  
E  
BR  
G  
H  
I  
J  
K  
L  
M  
N  
O  
P

# BRAKE BOOSTER

< REMOVAL AND INSTALLATION >

## BRAKE BOOSTER

Exploded View

INFOID:000000012894335

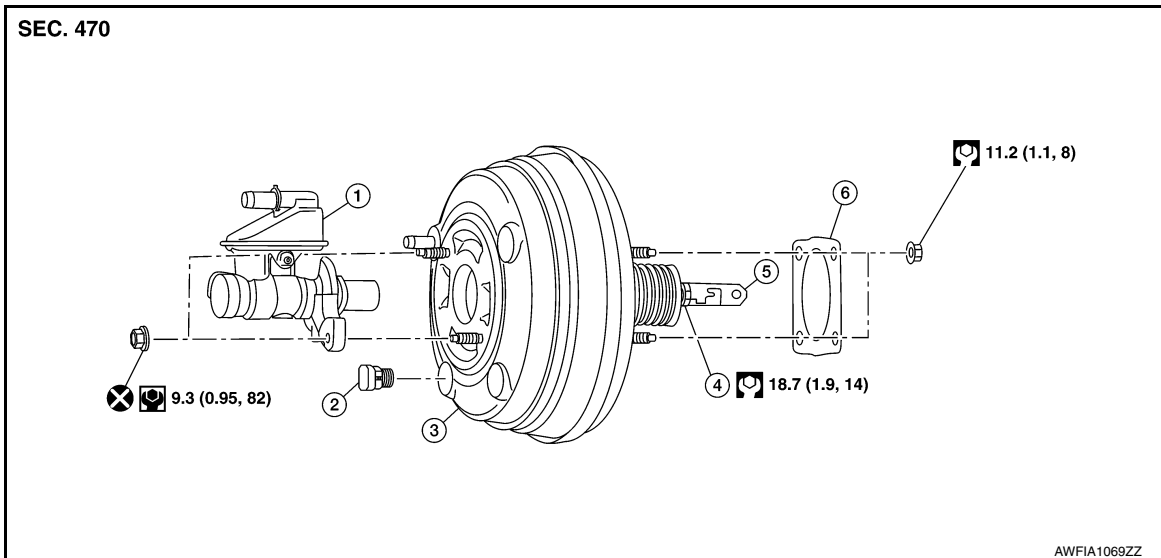

- |                             |                  |                  |
|-----------------------------|------------------|------------------|
| 1. Master cylinder assembly | 2. Vacuum sensor | 3. Brake booster |
| 4. Lock nut                 | 5. Clevis        | 6. Gasket        |

## Removal and Installation

INFOID:000000012894336

### REMOVAL

1. Remove instrument lower panel LH. Refer to [IP-24, "Removal and Installation"](#).
2. Remove harness clip.
3. Remove the snap pin (1) and clevis pin (2) from the brake pedal.

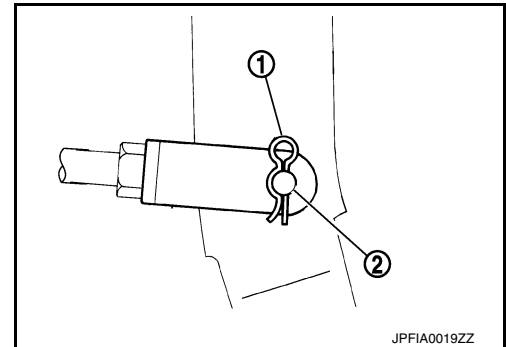

4. Remove the bolt (A) from the Intelligent Key® warning buzzer (1) from the strut tower and place Intelligent Key® warning buzzer (1) aside.

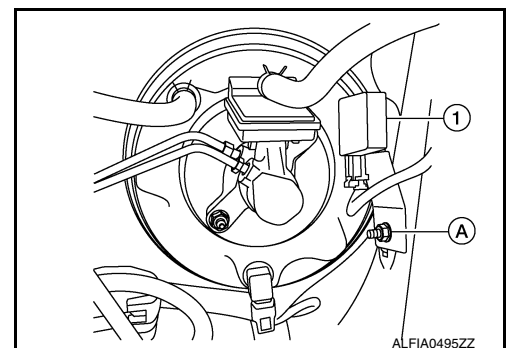

5. Remove master cylinder assembly. Refer to [BR-29, "Removal and Installation"](#).
6. Disconnect vacuum hose from brake booster. Refer to [BR-34, "Exploded View"](#).



# BRAKE BOOSTER

## < REMOVAL AND INSTALLATION >

7. Disconnect the harness connector from the vacuum sensor.
8. Remove the four nuts on the brake booster.  
**CAUTION:**  
**Secure the brake booster to avoid damage to components.**
9. Remove the brake booster from the dash panel on the engine room side.  
**CAUTION:**  
**Do not deform or bend the brake pipes.**

## INSTALLATION

1. Loosen lock nut (1) and adjust input rod (2) to the specified length (B).

**Length (B)** : Refer to [BR-53, "Brake Booster"](#).

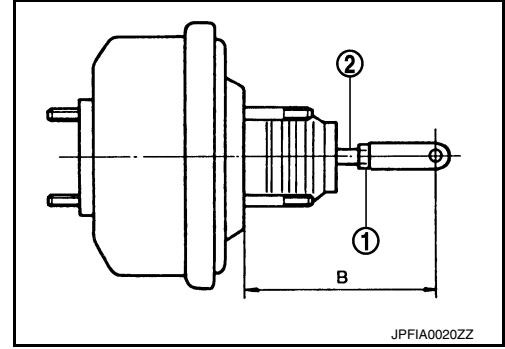

2. After adjustment, temporarily tighten lock nut to install booster assembly.
3. Install gasket between the brake booster and dash panel.
4. Install the brake booster to the dash panel from the engine room side.  
**CAUTION:**  
**Do not damage brake booster stud bolt threads during installation.**
5. Install the four nuts to the brake booster and brake pedal assembly. Refer to [BR-32, "Exploded View"](#).
6. Connect the harness connector to the vacuum sensor.
7. Install the Intelligent Key® warning buzzer to the strut tower.
8. Connect vacuum hose to brake booster. Refer to [BR-34, "Exploded View"](#).
9. Install master cylinder assembly. Refer to [BR-29, "Removal and Installation"](#).
10. Install the cowl top extension. Refer to [EXT-35, "Removal and Installation - Cowl Top Extension"](#).
11. Install the clevis pin and snap pin to the brake pedal.
12. Install the harness clip.
13. Adjust the brake pedal. Refer to [BR-13, "Adjustment"](#).
14. Install instrument lower panel LH. Refer to [IP-24, "Removal and Installation"](#).
15. Bleed the brake system. Refer to [BR-14, "Bleeding Brake System"](#).
16. Inspect the brake booster. Refer to [BR-10, "Inspection"](#).

# VACUUM LINES

< REMOVAL AND INSTALLATION >

## VACUUM LINES

### Exploded View

INFOID:000000012894337

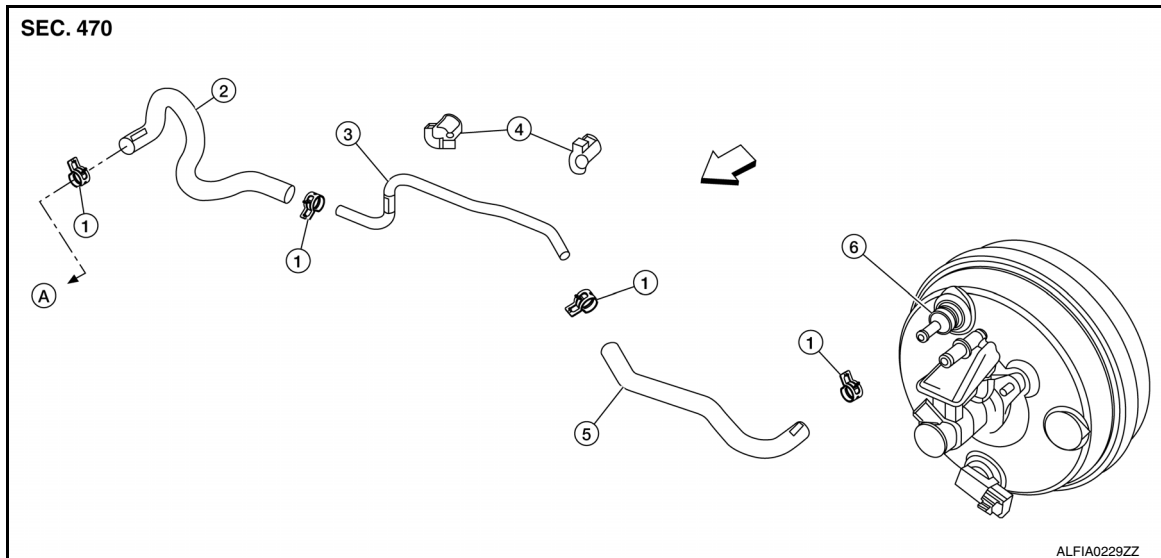

- |                       |                |                |
|-----------------------|----------------|----------------|
| 1. Clamp              | 2. Vacuum hose | 3. Vacuum pipe |
| 4. Clip               | 5. Vacuum hose | 6. Check valve |
| A. To intake manifold | ↔ Front        |                |

### Removal and Installation

INFOID:000000012894338

#### REMOVAL

1. Remove the sub tank bracket nuts (A), release the brake fluid level switch harness clips (B) and position the sub tank assembly (1) aside.

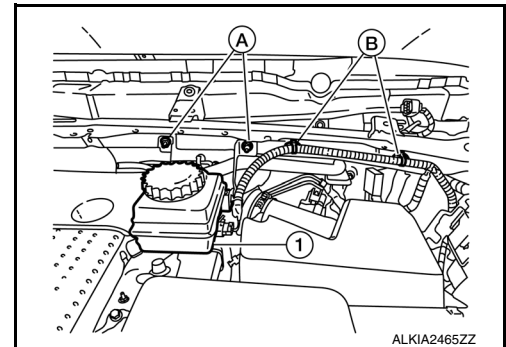

2. Remove air cleaner case as an assembly. Refer to [EM-26, "Exploded View"](#).
3. Remove engine cover. Refer to [EM-25, "Removal and Installation"](#).
4. Disconnect the vacuum hose from the brake booster.
5. Disconnect the vacuum hose from the engine intake manifold.
6. Disconnect clips from vacuum pipe.
7. Remove the vacuum hose assembly.

#### INSPECTION AFTER REMOVAL

##### Visual Inspection

Check for correct installation, damage and deterioration of the vacuum hoses and pipe.

##### Valve Air-tightness Check

- Connect a suitable tool at each end of the vacuum hose to inspect the check valve operation.

# VACUUM LINES

## < REMOVAL AND INSTALLATION >

- Vacuum applied at booster end : Refer to [BR-53, "Check Valve"](#).
- Vacuum applied at intake manifold end : Refer to [BR-53, "Check Valve"](#).

- Replace the vacuum hose with check valve if out of specification.

### INSTALLATION

Installation is in the reverse order of removal.

#### CAUTION:

- Because the vacuum hose contains a check valve, the vacuum hose must be installed in the correct position for proper operation. Refer to the stamp on the end of the vacuum hose to confirm correct installation. The brake booster will not operate normally if the vacuum hose with the check valve is installed in the wrong direction.
- Insert the vacuum pipe into the vacuum hose at least 24 mm (0.94 in) as shown.
- Do not use lubricating oil during installation.

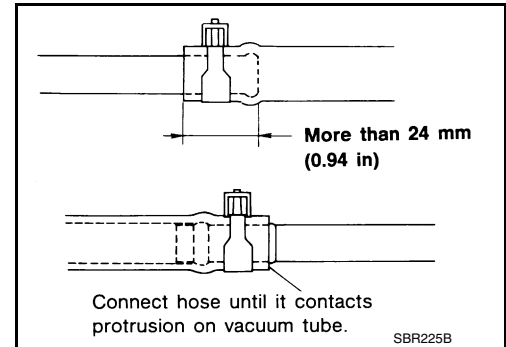

A  
B  
C  
D  
E  
BR  
G  
H  
I  
J  
K  
L  
M  
N  
O  
P

# FRONT DISC BRAKE

< REMOVAL AND INSTALLATION >

## FRONT DISC BRAKE

### BRAKE PAD

### BRAKE PAD : Exploded View

INFOID:000000012894339

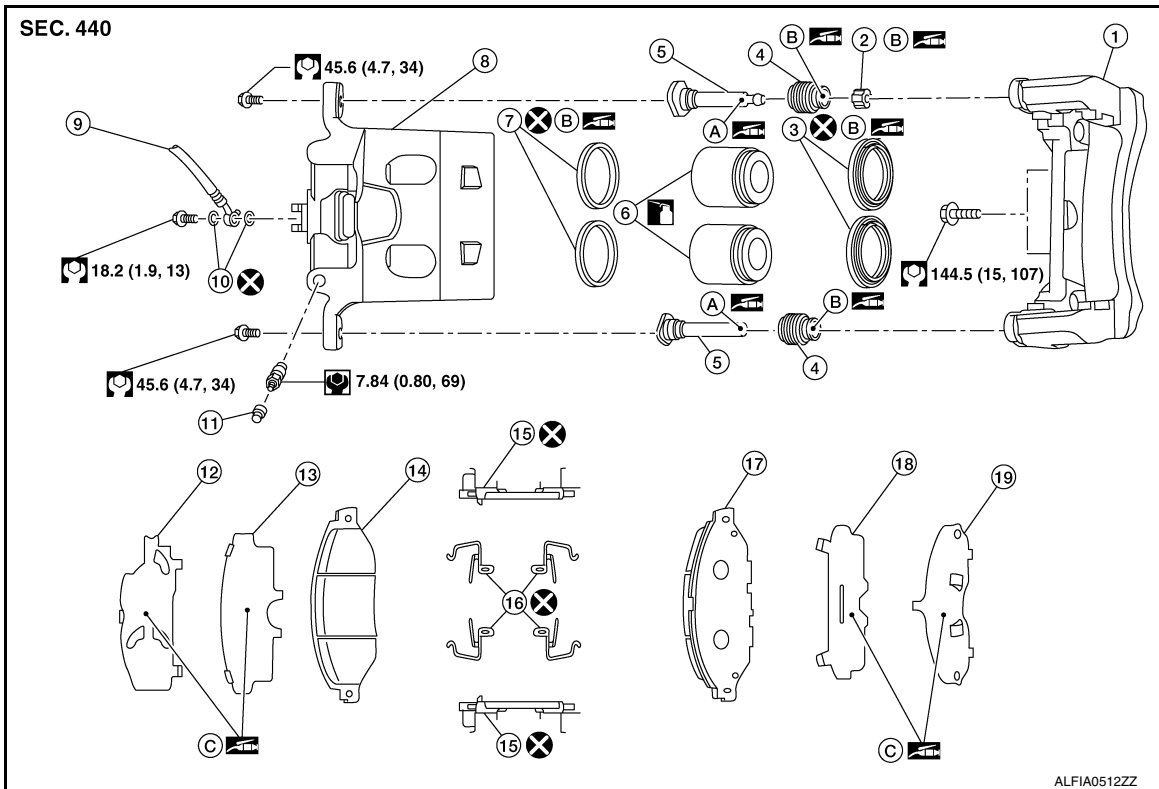

- |                            |                       |                      |
|----------------------------|-----------------------|----------------------|
| 1. Torque member           | 2. Bushing            | 3. Piston boot       |
| 4. Slide pin boot          | 5. Slide pin          | 6. Piston            |
| 7. Piston seal             | 8. Brake caliper body | 9. Brake hose        |
| 10. Copper sealing washers | 11. Bleeder cap       | 12. Inner shim cover |
| 13. Inner shim             | 14. Inner pad         | 15. Pad retainer     |
| 16. Anti-rattle clip       | 17. Outer pad         | 18. Outer shim       |
| 19. Outer shim cover       | A. Nigrove Rx-2       | B. Rubber grease     |
| C. Molykote® AS-880N       |                       |                      |

 Apply brake fluid.

### BRAKE PAD : Removal and Installation

INFOID:000000012894340

#### REMOVAL

#### **WARNING:**

Clean dust on brake caliper and brake pad with a vacuum dust collector to minimize the hazards of airborne particles or other material.

#### **CAUTION:**

- Do not depress the brake pedal while removing the brake pads because the pistons may pop out.
- It is not necessary to remove bolts on torque member and brake hose except for disassembly or replacement of brake caliper. For brake pad removal, hang brake caliper with a wire so as not to stretch brake hose.
- If brake fluid or grease adheres to the brake caliper or disc brake rotor, quickly wipe it off.
- Do not reuse drained brake fluid.

1. Observe brake fluid level in the sub tank. Partially drain brake fluid if necessary. Refer to [BR-14, "Drain and Refill"](#).

# FRONT DISC BRAKE

## < REMOVAL AND INSTALLATION >

2. Remove the front wheels and tires using power tool.
3. Remove slide pin bolts.
4. Remove the brake caliper from the torque member. Leaving brake hose attached, reposition the brake caliper aside with wire.
5. Remove the brake pads, shims, shim covers, pad retainers, and anti-rattle clips from the torque member.  
**CAUTION:**
  - Do not reuse the pad retainers and anti-rattle clips.
  - Do not damage the piston boot.
  - Do not drop the brake pads, shims, or the shim covers.
  - Note the position of components during removal to aid with installation.
6. Compress the front caliper pistons.

## INSTALLATION

1. Install the new pad retainers and anti-rattle clips to the torque member.  
**CAUTION:**
  - Do not reuse the pad retainers and anti-rattle clips.
  - Do not deform the pad retainers.
  - Verify that the pad retainers are secured properly to the torque member.
2. Apply Molykote® AS-880N grease to the mating faces between the inner shim, inner shim cover, outer shim and outer shim cover and install them to the brake pad. Refer to [BR-36. "BRAKE PAD : Exploded View"](#).  
**CAUTION:**  
**When installing new brake pads, replace the shims and shim covers.**
3. Install the brake pads to the torque member.
4. Using a suitable tool, press the pistons into the brake caliper.  
**CAUTION:**  
**Do not damage the piston boot.**
5. Install the brake caliper to the torque member.
6. Install the slide pin bolts and tighten to specification. Refer to [BR-36. "BRAKE PAD : Exploded View"](#).
7. Depress the brake pedal several times and verify that drag does not exist.
8. Install the front wheels and tires. Refer to [WT-66. "Removal and Installation"](#).
9. Check brake fluid level and refill as necessary. Refer to [BR-8. "Inspection"](#).

## INSPECTION AFTER INSTALLATION

1. Check the drag of front disc brake. If any drag is found, follow the procedure described below.
2. Remove brake pads.
3. Using a suitable tool, press the pistons into the brake caliper body.  
**CAUTION:**  
**Do not damage the piston boots.**
4. Install brake pads.
5. Depress the brake pedal several times.
6. Check the drag of front disc brake again. If any drag is found, disassemble the brake caliper body.
7. Burnish contact surfaces after refinishing or replacing disc brake rotors or if a soft pedal occurs at very low mileage. Refer to [BR-52. "Brake Pedal"](#).

## BRAKE CALIPER ASSEMBLY

### BRAKE CALIPER ASSEMBLY : Exploded View

INFOID:000000012894341

# FRONT DISC BRAKE

## < REMOVAL AND INSTALLATION >

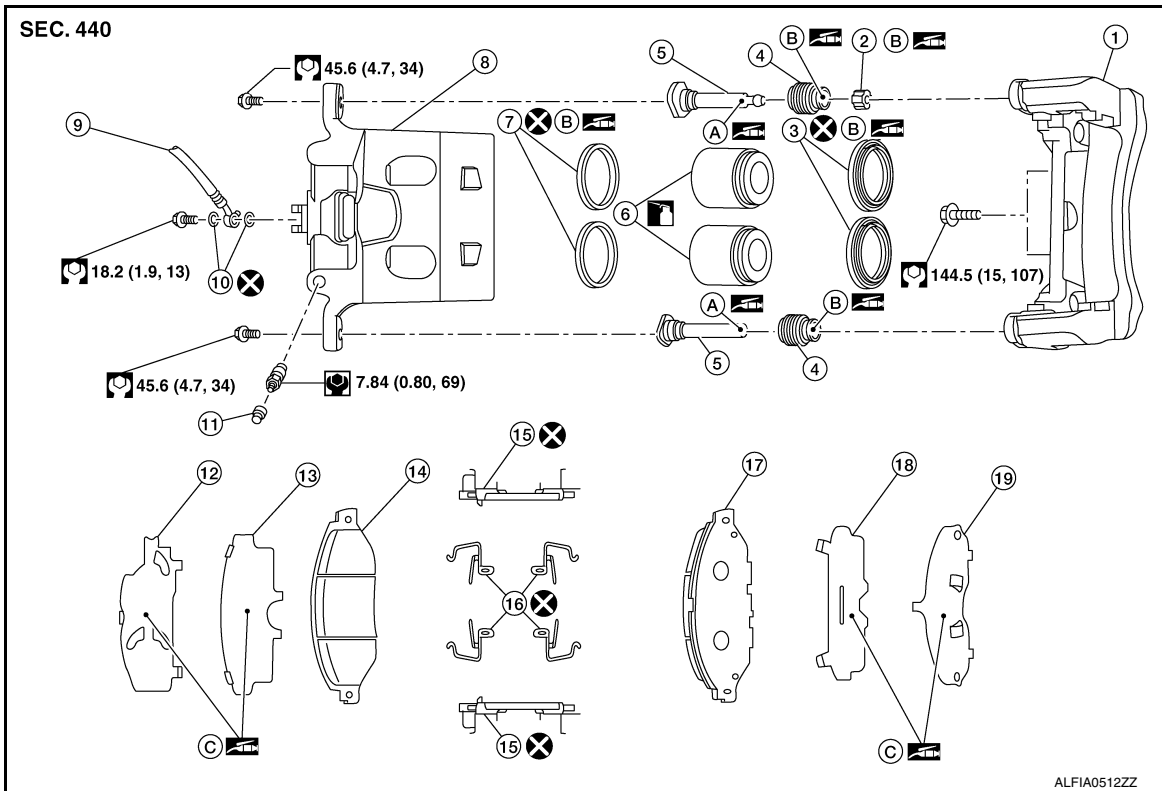

- |                            |                       |                      |
|----------------------------|-----------------------|----------------------|
| 1. Torque member           | 2. Bushing            | 3. Piston boot       |
| 4. Slide pin boot          | 5. Slide pin          | 6. Piston            |
| 7. Piston seal             | 8. Brake caliper body | 9. Brake hose        |
| 10. Copper sealing washers | 11. Bleeder cap       | 12. Inner shim cover |
| 13. Inner shim             | 14. Inner pad         | 15. Pad retainer     |
| 16. Anti-rattle clip       | 17. Outer pad         | 18. Outer shim       |
| 19. Outer shim cover       | A. Nigrove Rx-2       | B. Rubber grease     |
| C. Molykote® AS-880N       |                       |                      |

: Apply brake fluid.

## BRAKE CALIPER ASSEMBLY : Removal and Installation

INFOID:000000012894342

### WARNING:

Clean dust on brake caliper and brake pad with a vacuum dust collector to minimize the hazard of airborne particles or other materials.

### CAUTION:

- Do not depress the brake pedal.
- Do not spill or splash brake fluid on painted areas; it may cause paint damage. If brake fluid is splashed on painted areas, wash it away with water immediately.
- Do not bend, twist or pull the brake hoses and piping.
- Do not reuse drained brake fluid.

### NOTE:

When removing components such as hoses, tubes/lines, etc., cap or plug openings to prevent fluid from spilling.

### REMOVAL

1. Remove reservoir cap from the reservoir tank.
2. Remove front wheels and tires using power tool.
3. Secure the disc brake rotor using wheel nuts.
4. Remove union bolt, copper sealing washers, and disconnect brake hose from brake caliper. Discard the copper sealing washers.

# FRONT DISC BRAKE

## < REMOVAL AND INSTALLATION >

### CAUTION:

**Do not reuse copper sealing washers.**

5. Remove slide pin bolts and the brake caliper.

### CAUTION:

**Do not drop brake pads or caliper.**

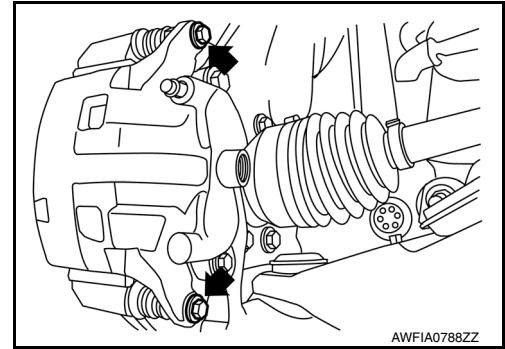

6. Remove the brake pads from the torque member.

### CAUTION:

- Do not damage the piston boot.
- Do not drop the brake pads, shims, or the shim covers.
- Note the position of components during removal to aid with installation.

## INSTALLATION

1. Install the brake pads in the torque member.

### CAUTION:

- Do not damage the piston boot.
- Do not drop the brake pads, shims, or the shim covers.

2. Position the brake caliper to torque member and install the slide pin bolts. Tighten to specification.

3. Assemble the union bolt (A) and the copper sealing washers (1) to the brake hose and install it as an assembly to the brake caliper. Align the brake hose L-pin by aligning it with the brake caliper hole, and tighten the union bolt (1) to the specified torque.

### CAUTION:

**Do not reuse copper sealing washers.**

4. Refill with new brake fluid and perform the air bleeding. Refer to [BR-14, "Bleeding Brake System"](#).

### CAUTION:

- Do not reuse drained brake fluid.
- Do not spill or splash brake fluid on the disc brake rotor.

5. Install the front wheels and tires. Refer to [WT-66, "Removal and Installation"](#).

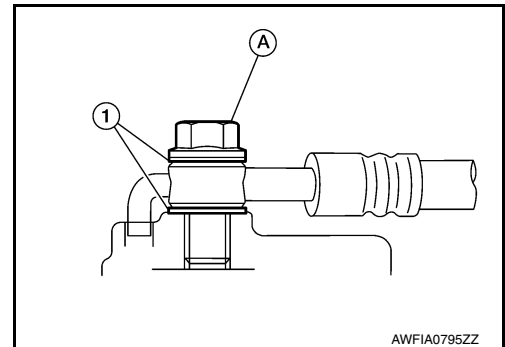

## INSPECTION AFTER INSTALLATION

1. Check the drag of front disc brake. If any drag is found, follow the procedure described below.
2. Remove brake pads.
3. Using a suitable tool, press the pistons into the brake caliper body.

### CAUTION:

**Do not damage the piston boots.**

4. Install brake pads.
5. Depress the brake pedal several times.
6. Check the drag of front disc brake again. If any drag is found, disassemble the brake caliper body.
7. Burnish contact surfaces after refinishing or replacing disc brake rotors or if a soft pedal occurs at very low mileage. Refer to [BR-52, "Brake Pedal"](#).

## DISC BRAKE ROTOR

# FRONT DISC BRAKE

< REMOVAL AND INSTALLATION >

## DISC BRAKE ROTOR : Exploded View

INFOID:000000012894343

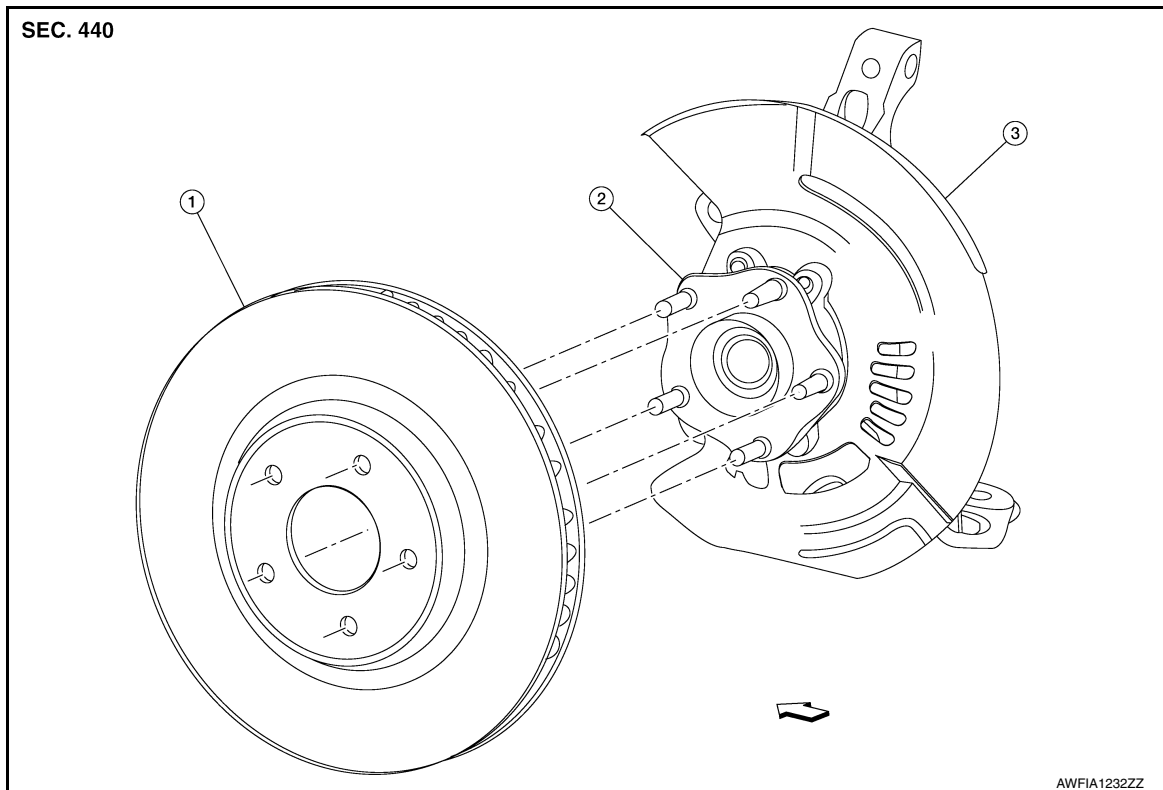

1. Front disc brake rotor      2. Front wheel hub and bearing assembly      3. Splash guard

⇐ Front

## DISC BRAKE ROTOR : Removal and Installation

INFOID:000000012894344

### REMOVAL

1. Remove front wheels and tires using power tool. Refer to [WT-66. "Removal and Installation"](#).
2. Remove front brake caliper torque member bolts. Leaving brake hose attached, reposition brake caliper aside with wire. Refer to [BR-36. "BRAKE PAD : Exploded View"](#).
3. Place alignment marks (A) on front disc brake rotor and wheel hub and bearing, then remove front disc brake rotor.

### **CAUTION:**

**Do not drop the disc brake rotor.**

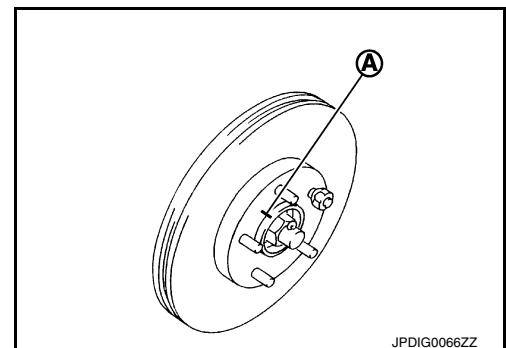

### INSTALLATION

Installation is in the reverse order of removal.



# REAR DISC BRAKE

< REMOVAL AND INSTALLATION >

## REAR DISC BRAKE

### BRAKE PAD

### BRAKE PAD : Exploded View

INFOID:000000012894345

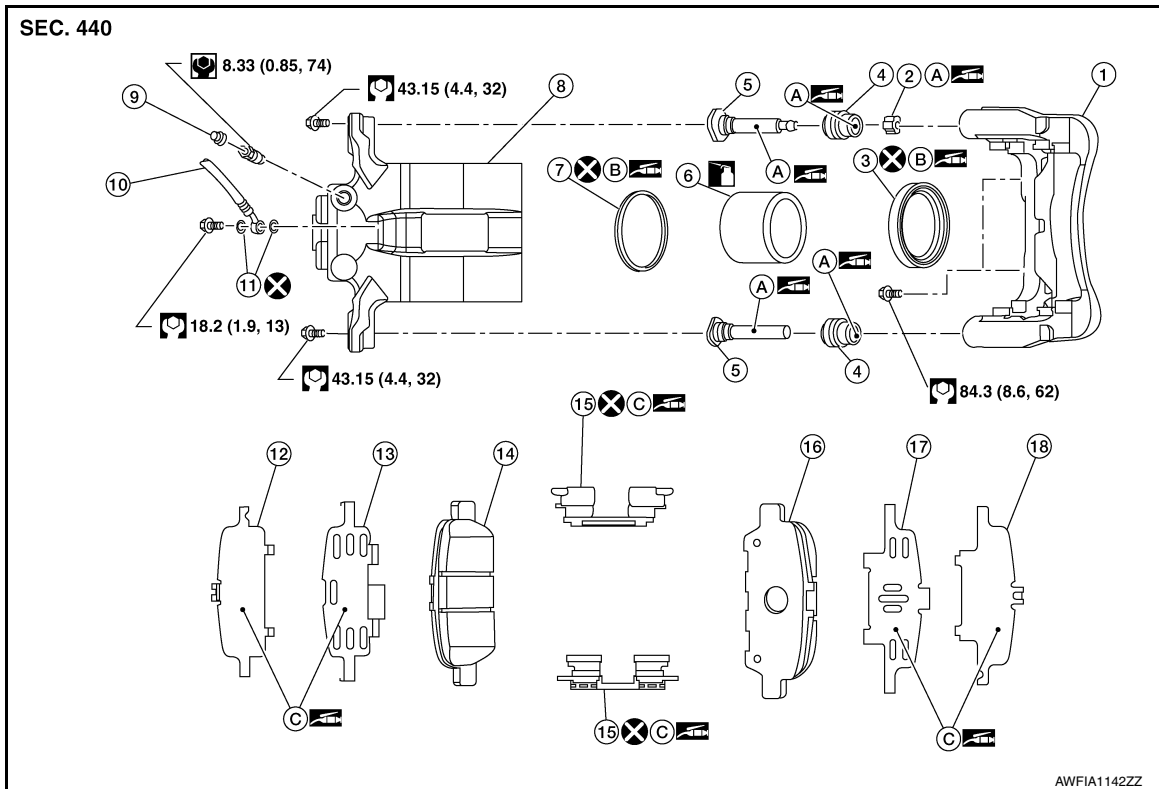

- |                   |                            |                      |
|-------------------|----------------------------|----------------------|
| 1. Torque member  | 2. Bushing                 | 3. Piston boot       |
| 4. Slide pin boot | 5. Slide pin               | 6. Piston            |
| 7. Piston seal    | 8. Brake caliper body      | 9. Bleeder cap       |
| 10. Brake hose    | 11. Copper sealing washers | 12. Inner shim cover |
| 13. Inner shim    | 14. Inner pad              | 15. Pad retainer     |
| 16. Outer pad     | 17. Outer shim             | 18. Outer shim cover |
| A. Niglube Rx-2   | B. Rubber grease           | C. Molykote® AS-880N |

: Apply brake fluid.

### BRAKE PAD : Removal and Installation

INFOID:000000012894346

#### REMOVAL

#### **WARNING:**

Clean dust on brake caliper and brake pad with a vacuum dust collector to minimize the hazards of airborne particles or other material.

#### **CAUTION:**

- Do not depress the brake pedal while removing the brake pads because the piston may pop out.
- It is not necessary to remove bolts on torque member and brake hose except for disassembly or replacement of brake caliper. For brake pad removal, hang brake caliper with a wire so as not to stretch brake hose.
- If brake fluid or grease adheres to the brake caliper or disc brake rotor, quickly wipe it off.
- Do not reuse drained brake fluid.

1. Observe brake fluid level in sub tank. Partially drain brake fluid if necessary. Refer to [BR-14, "Drain and Refill"](#).
2. Remove the rear wheels and tires using power tool.

# REAR DISC BRAKE

## < REMOVAL AND INSTALLATION >

- Loosen the lower slide pin bolt and remove the upper slide pin bolt.
- Using the lower slide pin bolt as a pivot, swing the brake caliper down from the torque member. Leaving the brake hose attached, support the brake caliper with wire.
- Remove the brake pads, shims, shim covers, and pad retainers from the torque member.

**CAUTION:**

- Do not reuse the pad retainers.
- Do not damage the piston boot.
- Do not drop the brake pads, shims, or the shim covers.
- Note the position of components during removal to aid with installation.

- Compress the rear caliper piston.

## INSTALLATION

- Install the new pad retainers to the torque member.

**CAUTION:**

- Do not reuse the pad retainers.
- Do not deform the pad retainers.
- Verify that the pad retainers are secured properly to the torque member.

- Apply Molykote® AS-880N grease to the mating faces between the brake pads and to the pad retainers. Refer to [BR-41, "BRAKE PAD : Exploded View"](#).

- Apply Molykote® AS-880N grease to the mating faces between the brake pads, inner shim (1) and outer shim (2). Install components to the brake pad. Refer to [BR-41, "BRAKE PAD : Exploded View"](#).

**CAUTION:**

**When installing new brake pads, replace the shims and shim covers.**

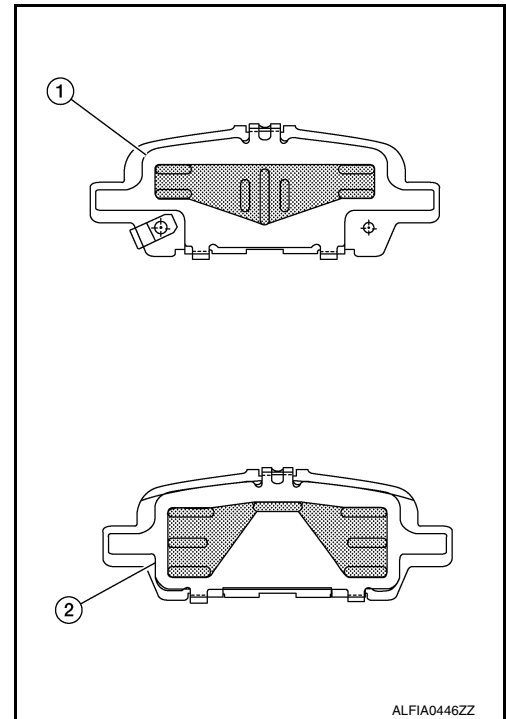

- Install the brake pads to the torque member.
  - Using a suitable tool, press the piston into the brake caliper.
- CAUTION:**  
**Do not damage the piston boot.**
- Using the lower slide pin bolt as a pivot, swing the brake caliper up to the torque member.
  - Install the upper slide pin bolts. Tighten all slide pin bolts to specification. Refer to [BR-41, "BRAKE PAD : Exploded View"](#).
  - Depress the brake pedal several times and verify that drag does not exist.
  - Install the front wheels and tires. Refer to [WT-66, "Removal and Installation"](#).
  - Check brake fluid level and refill as necessary. Refer to [BR-8, "Inspection"](#).

## INSPECTION AFTER INSTALLATION

- Check the drag of rear disc brake. If any drag is found, follow the procedure described below.
- Remove brake pads.

# REAR DISC BRAKE

## < REMOVAL AND INSTALLATION >

3. Using a suitable tool, press the piston into the brake caliper body.  
**CAUTION:**  
**Do not damage the piston boots.**
4. Install brake pads.
5. Depress the brake pedal several times.
6. Check the drag of rear disc brake again. If any drag is found, disassemble the brake caliper body.
7. Burnish contact surfaces after refinishing or replacing disc brake rotors or if a soft pedal occurs at very low mileage. Refer to [BR-52, "Brake Pedal"](#).

## BRAKE CALIPER ASSEMBLY

### BRAKE CALIPER ASSEMBLY : Exploded View

INFOID:000000012894347

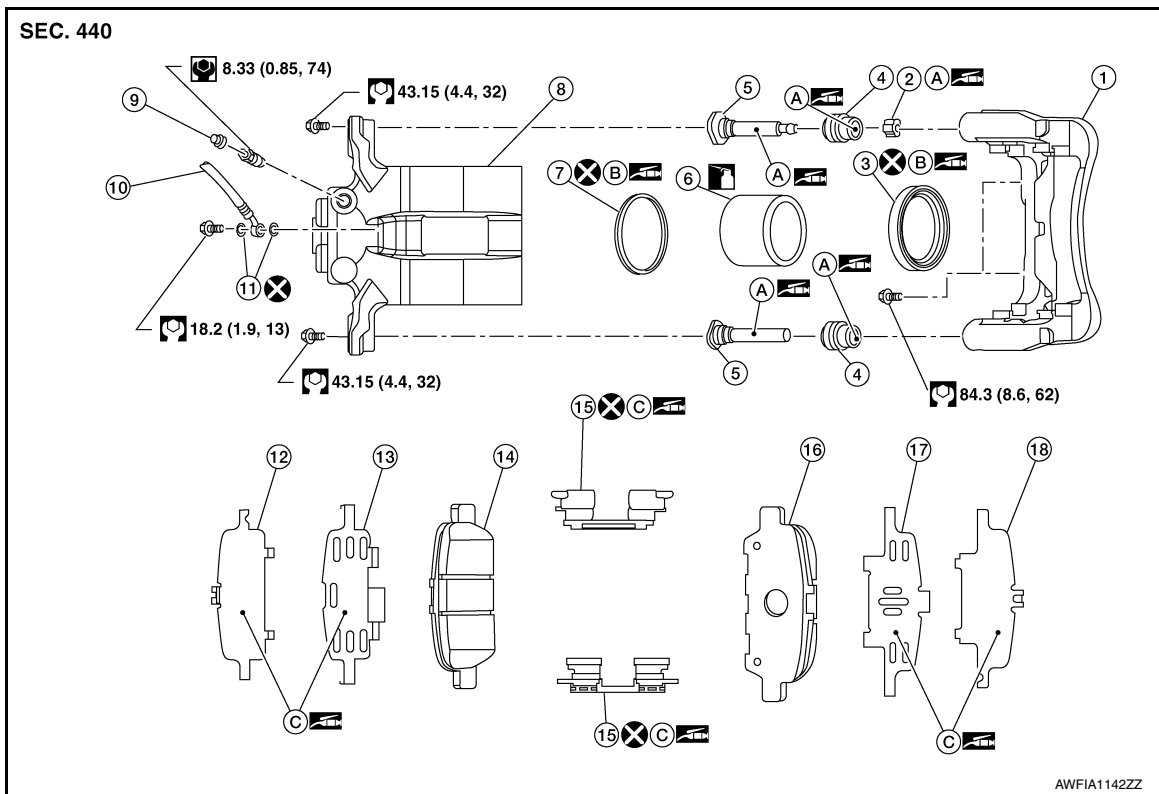

- |                   |                            |                      |
|-------------------|----------------------------|----------------------|
| 1. Torque member  | 2. Bushing                 | 3. Piston boot       |
| 4. Slide pin boot | 5. Slide pin               | 6. Piston            |
| 7. Piston seal    | 8. Brake caliper body      | 9. Bleeder cap       |
| 10. Brake hose    | 11. Copper sealing washers | 12. Inner shim cover |
| 13. Inner shim    | 14. Inner pad              | 15. Pad retainer     |
| 16. Outer pad     | 17. Outer shim             | 18. Outer shim cover |
| A. Niglube Rx-2   | B. Rubber grease           | C. Molykote® AS-880N |

: Apply brake fluid.

### BRAKE CALIPER ASSEMBLY : Removal and Installation

INFOID:000000012894348

#### **WARNING:**

Clean dust on brake caliper and brake pad with a vacuum dust collector to minimize the hazard of airborne particles or other materials.

#### **CAUTION:**

- Do not depress the brake pedal.

# REAR DISC BRAKE

## < REMOVAL AND INSTALLATION >

- Do not spill or splash brake fluid on painted areas; it may cause paint damage. If brake fluid is splashed on painted areas, wash it away with water immediately.
- Do not bend, twist or pull the brake hoses and piping.
- Do not reuse drained brake fluid.

### NOTE:

When removing components such as hoses, tubes/lines, etc., cap or plug openings to prevent fluid from spilling.

### REMOVAL

1. Remove reservoir cap from the reservoir tank.
2. Remove rear wheels and tires using power tool.
3. Secure the disc brake rotor using wheel nuts.
4. Remove union bolt, copper sealing washers, and disconnect brake hose from brake caliper. Discard the copper sealing washers.  
**CAUTION:**  
**Do not reuse copper sealing washers.**
5. Remove the torque member bolts. Remove the brake caliper and torque member from the vehicle as an assembly.
6. Remove the brake pads from the torque member.  
**CAUTION:**
  - Do not damage the piston boot.
  - Do not drop the brake pads, shims, or the shim covers.
  - Note the position of components during removal to aid with installation.
7. Remove the slide pin bolts and the brake caliper from the torque member.

### CAUTION:

- Do not drop the brake pads or brake caliper

### INSTALLATION

1. Install the brake pads to the torque member.  
**CAUTION:**
  - Do not damage the piston boot.
  - Do not drop the brake pads, shims, or the shim covers.
2. Install the brake caliper to torque member and install the slide pin bolts. Tighten to specification.
3. Install the brake caliper and torque member to the vehicle as an assembly. Install the torque member bolts.
4. Assemble the union bolt (A) and the copper sealing washers (1) to the brake hose and install it as an assembly to the brake caliper. Align the brake hose L-pin by aligning it with the brake caliper hole, and tighten the union bolt (1) to the specified torque.  
**CAUTION:**  
**Do not reuse copper sealing washers.**
5. Refill with new brake fluid and perform the air bleeding. Refer to [BR-14. "Bleeding Brake System"](#).  
**CAUTION:**
  - Do not reuse drained brake fluid.
  - Do not spill or splash brake fluid on the disc brake rotor.
6. Install the rear wheels and tires. Refer to [WT-66. "Removal and Installation"](#).

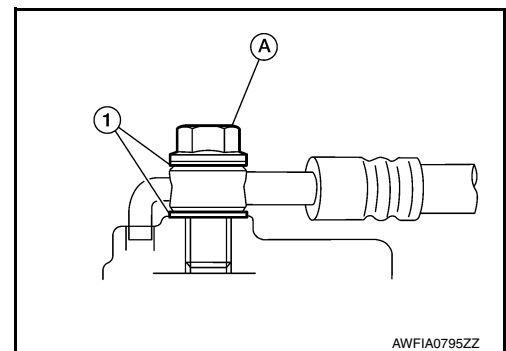

### INSPECTION AFTER INSTALLATION

1. Check the drag of rear disc brake. If any drag is found, follow the procedure described below.
2. Remove brake pads.
3. Using a suitable tool, press the pistons into the brake caliper body.  
**CAUTION:**  
**Do not damage the piston boots.**
4. Install brake pads.
5. Depress the brake pedal several times.

# REAR DISC BRAKE

## < REMOVAL AND INSTALLATION >

6. Check the drag of rear disc brake again. If any drag is found, disassemble the brake caliper body.
7. Burnish contact surfaces after refinishing or replacing disc brake rotors or if a soft pedal occurs at very low mileage. Refer to [BR-52. "Brake Pedal"](#).

## DISC BRAKE ROTOR

### DISC BRAKE ROTOR : Exploded View

INFOID:000000012894349

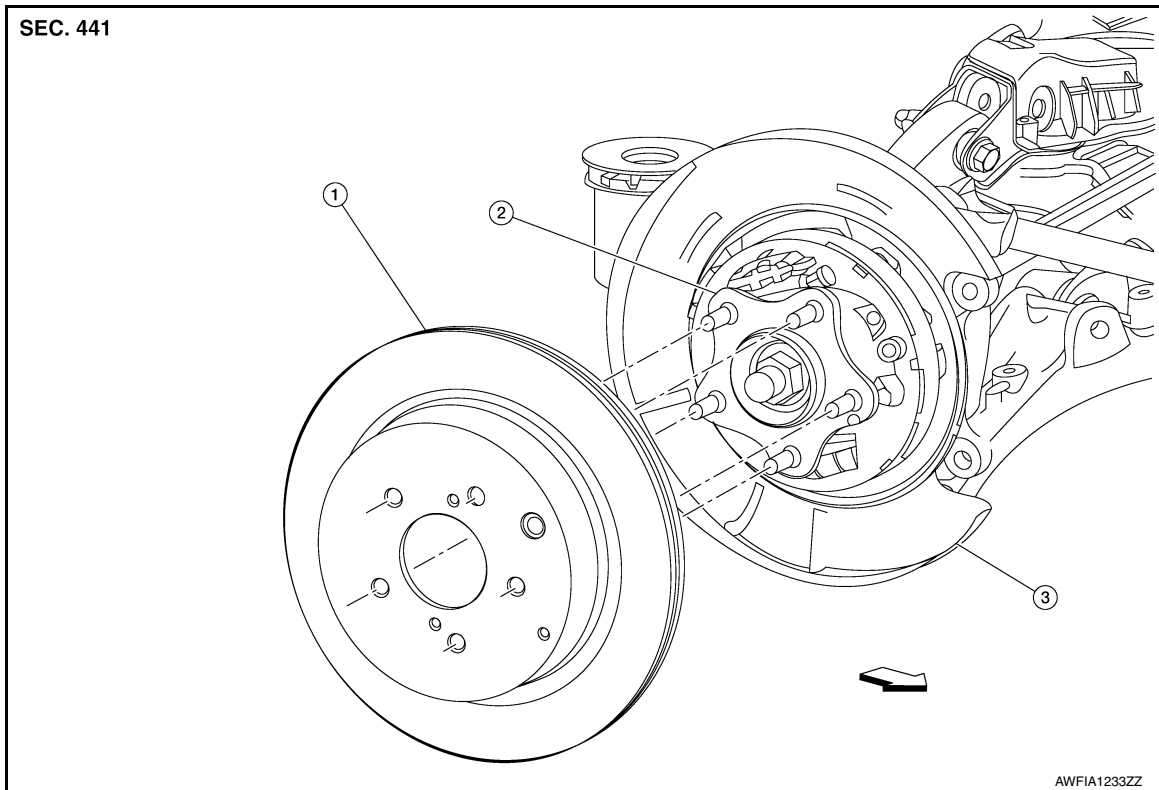

1. Rear disc brake rotor

2. Rear wheel hub and bearing

3. Splash guard

⇐ Front

### DISC BRAKE ROTOR : Removal and Installation

INFOID:000000012894350

#### REMOVAL

1. Remove rear wheels and tires using power tool. Refer to [WT-66. "Removal and Installation"](#).
2. Remove rear brake caliper torque member bolts. Leaving brake hose attached, reposition brake caliper aside with wire. Refer to [BR-41. "BRAKE PAD : Exploded View"](#).
3. Place alignment marks (A) on rear disc brake rotor and wheel hub and bearing, then remove rear disc brake rotor.

#### **CAUTION:**

**Do not drop the disc brake rotor.**

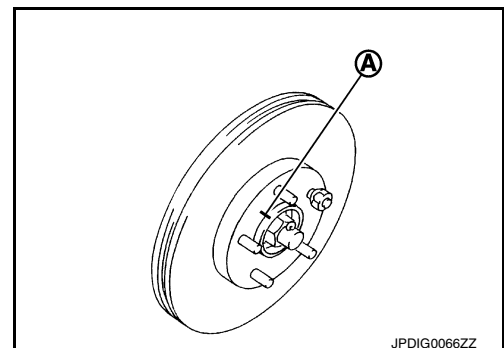

#### INSTALLATION

Installation is in the reverse order of removal.

# FRONT DISC BRAKE

< UNIT DISASSEMBLY AND ASSEMBLY >

## UNIT DISASSEMBLY AND ASSEMBLY

### FRONT DISC BRAKE

Exploded View

INFOID:000000012894351

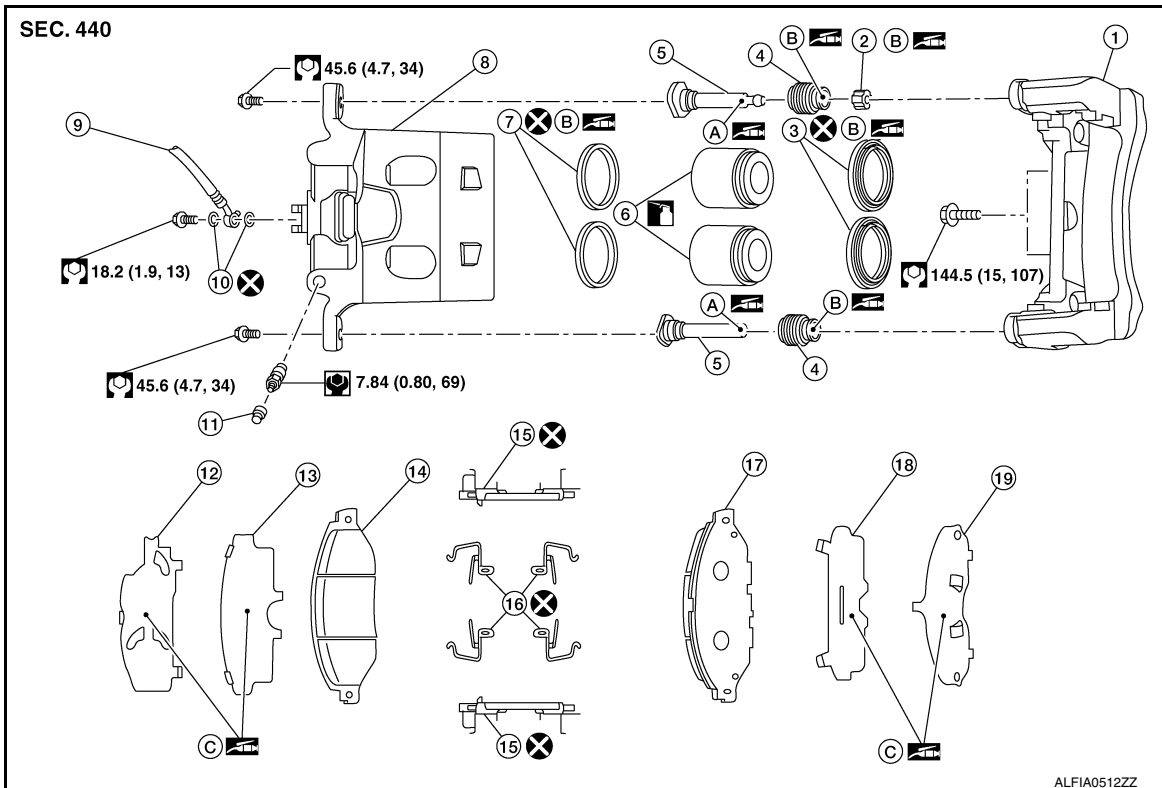

ALFIA0512ZZ

- |                            |                       |                      |
|----------------------------|-----------------------|----------------------|
| 1. Torque member           | 2. Bushing            | 3. Piston boot       |
| 4. Slide pin boot          | 5. Slide pin          | 6. Piston            |
| 7. Piston seal             | 8. Brake caliper body | 9. Brake hose        |
| 10. Copper sealing washers | 11. Bleeder cap       | 12. Inner shim cover |
| 13. Inner shim             | 14. Inner pad         | 15. Pad retainer     |
| 16. Anti-rattle clip       | 17. Outer pad         | 18. Outer shim       |
| 19. Outer shim cover       | A. Nigrove Rx-2       | B. Rubber grease     |
| C. Molykote® AS-880N       |                       |                      |

 Apply brake fluid.

### Disassembly and Assembly

INFOID:000000012894352

#### DISASSEMBLY

1. Remove the brake caliper from the vehicle. Refer to [BR-38. "BRAKE CALIPER ASSEMBLY : Removal and Installation"](#).
2. Remove slide pins and slide pin boots from torque member.

# FRONT DISC BRAKE

## < UNIT DISASSEMBLY AND ASSEMBLY >

- Place a wooden block in brake caliper body and blow air from union bolt hole to remove pistons and piston boots.

**WARNING:**

**Do not get fingers caught between pistons and brake caliper body.**

**CAUTION:**

**Do not reuse piston boots.**

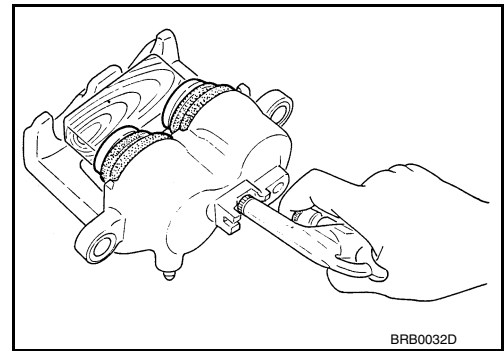

- Remove piston seals from brake caliper body using suitable tool.

**CAUTION:**

- Do not damage cylinder inner wall.
- Do not reuse piston seals.

- Remove bleeder valve and cap.

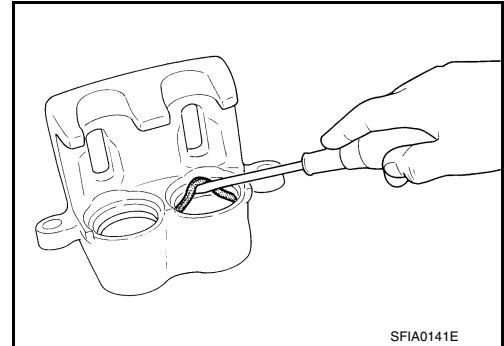

## INSPECTION AFTER DISASSEMBLY

### Brake Caliper Body

Check the inner wall of the brake caliper body for rust, wear, cracks or damage. Replace the brake caliper body if any abnormal condition is detected.

**CAUTION:**

**Always clean with new brake fluid. Do not clean with mineral oil such as gasoline and light oil.**

### Torque Member

Check the torque member for rust, wear, cracks or damage. Replace the torque member if any abnormal condition is detected.

### Piston

Check the surface of the piston for rust, wear, cracks or damage. Replace the piston if any abnormal condition is detected.

**CAUTION:**

**Piston sliding surface is plated. Do not polish with sandpaper.**

### Slide Pin and Slide Pin Boot

Check the slide pins and slide pin boots for rust, wear, cracks or damage. Replace the parts if any abnormal condition is detected.

## ASSEMBLY

- Install bleeder valve and cap.
- Apply rubber grease to each piston seal (1), and install them to the brake caliper body.

**CAUTION:**

**Do not reuse piston seal.**

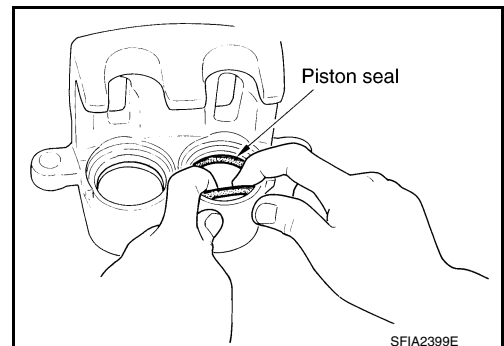

A  
B  
C  
D  
E  
BR  
G  
H  
I  
J  
K  
L  
M  
N  
O  
P

## FRONT DISC BRAKE

### < UNIT DISASSEMBLY AND ASSEMBLY >

3. Apply rubber grease to the piston boots. Cover each piston end with a piston boot, and then install cylinder side lip on piston boot securely into a groove on brake caliper body.

**CAUTION:**

**Do not reuse piston boots.**

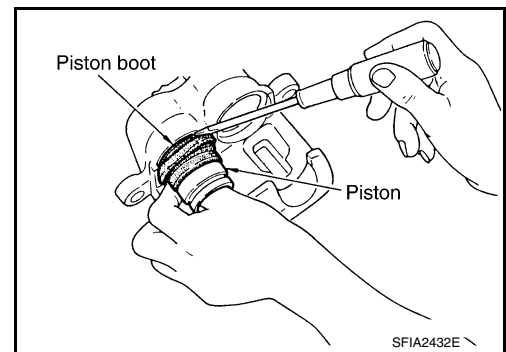

4. Apply brake fluid to each piston (1). Push each piston into cylinder body by hand and push piston boot (2) piston-side lip into the piston groove.

**CAUTION:**

**Press the piston evenly and vary the pressing point to prevent cylinder inner wall from being rubbed.**

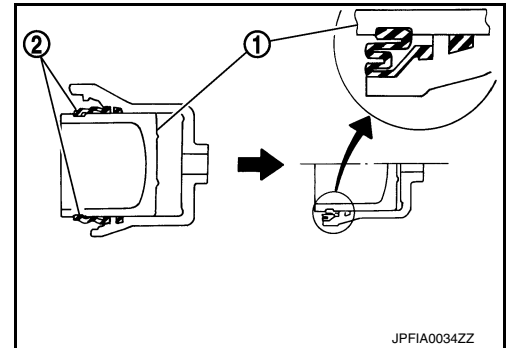

5. Apply rubber grease to bushing; install bushing to slide pin.
6. Apply rubber grease to slide pin boots. Install slide pin boots to torque member.
7. Apply Nigrove Rx-2 to slide pins. Install slide pins to torque member.
8. Install the brake caliper to the vehicle. Refer to [BR-38, "BRAKE CALIPER ASSEMBLY : Removal and Installation"](#).

### INSPECTION AFTER INSTALLATION

1. Check the drag of front disc brake. If any drag is found, follow the procedure described below.
2. Remove brake pads.
3. Using a suitable tool, press the pistons into the brake caliper body.  
**CAUTION:**  
**Do not damage the piston boots.**
4. Install brake pads.
5. Depress the brake pedal several times.
6. Check the drag of front disc brake again. If any drag is found, disassemble the brake caliper body.
7. Burnish contact surfaces after refinishing or replacing disc brake rotors or if a soft pedal occurs at very low mileage. Refer to [BR-52, "Brake Pedal"](#).



# REAR DISC BRAKE

< UNIT DISASSEMBLY AND ASSEMBLY >

## REAR DISC BRAKE

### Exploded View

INFOID:000000012894353

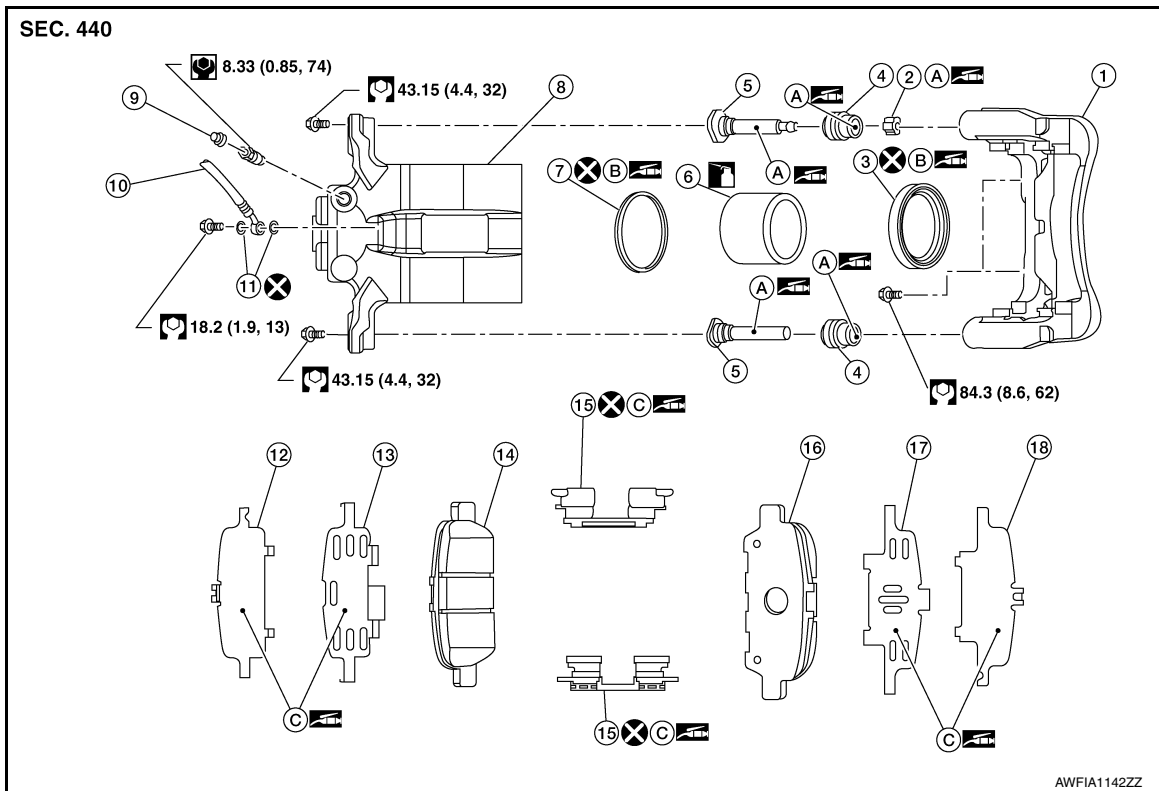

- |                   |                            |                      |
|-------------------|----------------------------|----------------------|
| 1. Torque member  | 2. Bushing                 | 3. Piston boot       |
| 4. Slide pin boot | 5. Slide pin               | 6. Piston            |
| 7. Piston seal    | 8. Brake caliper body      | 9. Bleeder cap       |
| 10. Brake hose    | 11. Copper sealing washers | 12. Inner shim cover |
| 13. Inner shim    | 14. Inner pad              | 15. Pad retainer     |
| 16. Outer pad     | 17. Outer shim             | 18. Outer shim cover |
| A. Niglube Rx-2   | B. Rubber grease           | C. Molykote® AS-880N |

: Apply brake fluid.

### Disassembly and Assembly

INFOID:000000012894354

#### DISASSEMBLY

1. Remove the brake caliper from the vehicle. Refer to [BR-43. "BRAKE CALIPER ASSEMBLY : Removal and Installation"](#).
2. Remove slide pin boots from torque member.
3. Remove slide pin bushing from slide pin.

## REAR DISC BRAKE

### < UNIT DISASSEMBLY AND ASSEMBLY >

4. Place a wooden block in the cylinder body and blow air from union bolt hole to remove piston and piston boot.

**WARNING:**

**Do not get fingers caught between pistons and brake caliper body.**

**CAUTION:**

**Do not reuse piston boot.**

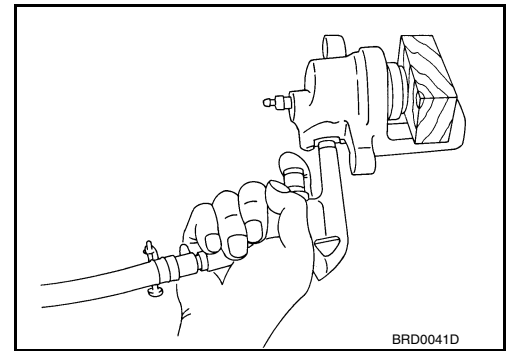

5. Remove piston seal from brake caliper body using suitable tool.

**CAUTION:**

- Do not damage cylinder inner wall.
- Do not reuse piston seal.

6. Remove bleeder valve and cap.

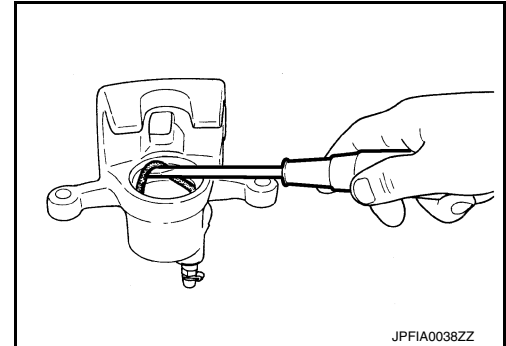

### INSPECTION AFTER DISASSEMBLY

#### Brake Caliper Body

Check the inner wall of the brake caliper body for rust, wear, cracks or damage. Replace the brake caliper body if any abnormal condition is detected.

**CAUTION:**

**Always clean with new brake fluid. Do not clean with mineral oil such as gasoline and light oil.**

#### Torque Member

Check the torque member for rust, wear, cracks or damage. Replace the torque member if any abnormal condition is detected.

#### Piston

Check the surface of the piston for rust, wear, cracks or damage. Replace the piston if any abnormal condition is detected.

**CAUTION:**

**Piston sliding surface is plated. Do not polish with sandpaper.**

#### Slide Pin and Slide Pin Boot

Check the slide pins and slide pin boots for rust, wear, cracks or damage. Replace the parts if any abnormal condition is detected.

### ASSEMBLY

1. Install bleeder valve and cap.
2. Apply rubber grease to piston seal (1), and install it to the brake caliper body.

**CAUTION:**

**Do not reuse piston seal.**

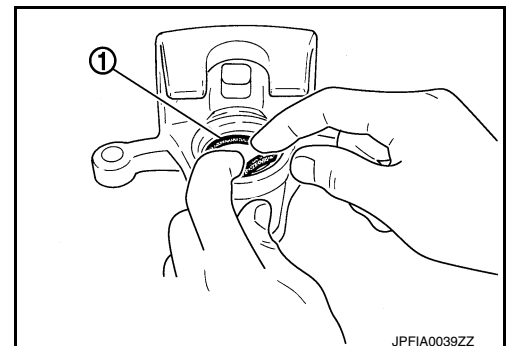

## REAR DISC BRAKE

### < UNIT DISASSEMBLY AND ASSEMBLY >

3. Apply rubber grease to piston boot (1). Cover the piston (2) end with the piston boot, and then install cylinder side lip on the piston boot securely into the groove on brake caliper body.

**CAUTION:**

**Do not reuse piston boot.**

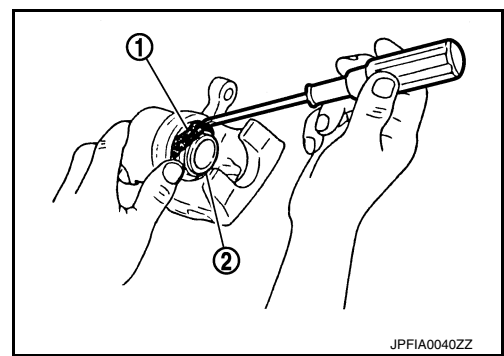

4. Apply brake fluid to piston (1). Push piston into brake caliper body by hand and push piston boot (2) piston side lip into the piston groove.

**CAUTION:**

**Press the piston evenly and vary the pressing point to prevent cylinder inner wall from contact.**

5. Apply Niglube Rx-2 grease to bushing; install bushing to slide pin.
6. Apply Niglube Rx-2 grease to slide pin boots and slide pins.
7. Install slide pin boots and slide pins to torque member.
8. Install the brake caliper to the vehicle. Refer to [BR-43, "BRAKE CALIPER ASSEMBLY : Removal and Installation"](#).

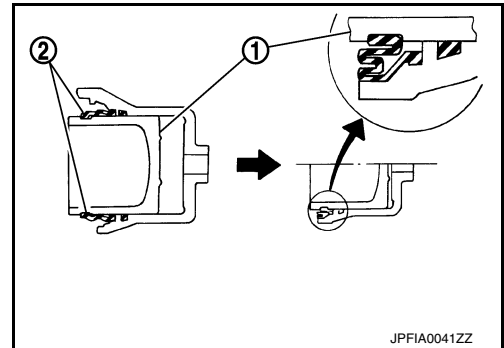

### INSPECTION AFTER INSTALLATION

1. Check the drag of rear disc brake. If any drag is found, follow the procedure described below.
2. Remove brake pads.
3. Using a suitable tool, press the pistons into the brake caliper body.  
**CAUTION:**  
**Do not damage the piston boots.**
4. Install brake pads.
5. Depress the brake pedal several times.
6. Check the drag of rear disc brake again. If any drag is found, disassemble the brake caliper body.
7. Burnish contact surfaces after refinishing or replacing disc brake rotors or if a soft pedal occurs at very low mileage. Refer to [BR-52, "Brake Pedal"](#).

# SERVICE DATA AND SPECIFICATIONS (SDS)

< SERVICE DATA AND SPECIFICATIONS (SDS)

## SERVICE DATA AND SPECIFICATIONS (SDS)

### SERVICE DATA AND SPECIFICATIONS (SDS)

#### General Specifications

INFOID:0000000012894355

Unit: mm (in)

Front disc brake	Cylinder bore diameter	45.0 (1.772) × 2
	Pad length × width × thickness	131.4 (5.173) × 53.0 (2.087) × 10 (0.394)
	Disc brake rotor outer diameter × thickness	320 (12.598) × 28 (1.102)
Rear disc brake	Cylinder bore diameter	42.86 (1.6874)
	Pad length × width × thickness	83 (3.268) × 33 (1.299) × 8.5 (0.335)
	Disc brake rotor outer diameter × thickness	308 (12.126) × 16 (0.630)
Master cylinder	Cylinder bore diameter	27 (1.063)
Control valve	Valve type	Electric brake force distribution
Recommended brake fluid		Refer to <a href="#">MA-12. "Fluids and Lubricants"</a> .

#### Brake Pedal

INFOID:0000000012894356

Unit: mm (in)

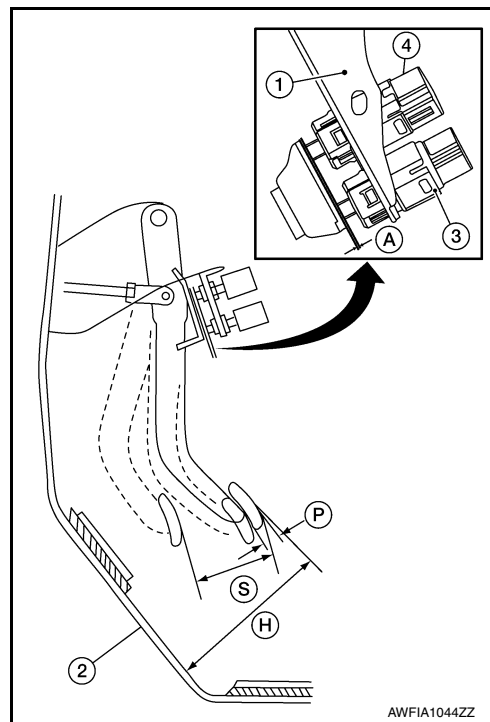

Item	Standard
Brake pedal height (H)	196.1 – 206.1 (7.72 – 8.11)
Clearance (A) between brake pedal bracket, stop lamp switch (3) and brake pedal position switch (4) contact ends	0.74 – 1.96 (0.0291 – 0.0772)
Brake pedal full stroke (S)	135.8 (5.35)
Brake pedal play (P)	4.6 (0.18)

# SERVICE DATA AND SPECIFICATIONS (SDS)

## < SERVICE DATA AND SPECIFICATIONS (SDS)

Unit: mm (in)

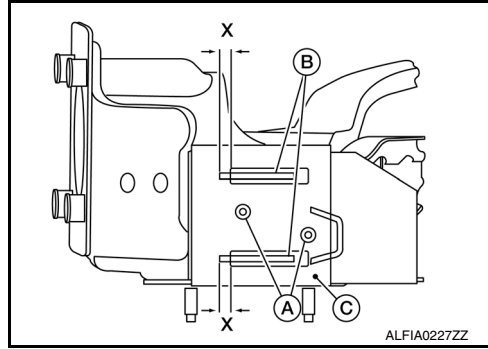

Overlap distance (X) between sub-bracket (B) and slide plate (C)

5.5 ± 0.5 (0.22 ± 0.02)

### Check Valve

INFOID:000000012894357

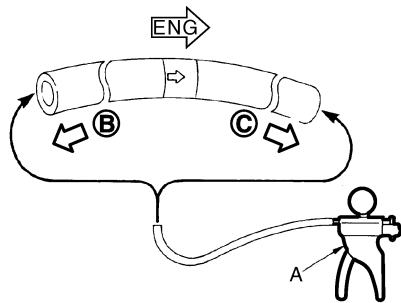

When suitable tool (A) is connected to booster side (B)

3.3 kPa (25 mmHg, 0.98 inHg) maximum vacuum loss for 15 seconds at vacuum of -66.7 kPa (-500 mmHg, -19.69 inHg)

When suitable tool (A) is connected to engine side (C)

No vacuum should exist.

### Brake Booster

INFOID:000000012894358

Unit: mm (in)

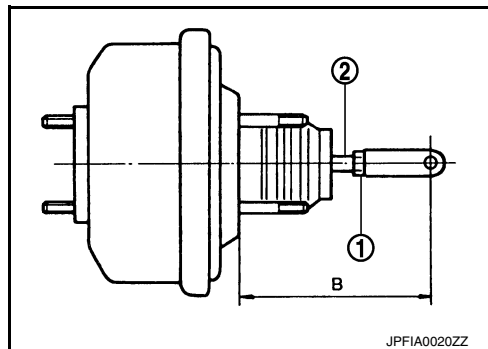

Input rod installation standard dimension (B)

(1): Lock nut  
(2): Input rod

127.0 ± 0.5 (5.00 ± 0.02)

### Front Disc Brake

INFOID:000000012894359

Unit: mm (in)

Item		Limit
Brake pad	Wear thickness	2 (0.079)

## SERVICE DATA AND SPECIFICATIONS (SDS)

### < SERVICE DATA AND SPECIFICATIONS (SDS)

Item		Limit
Disc brake rotor	Wear thickness	26 (1.024)
	Thickness variation (measured at 8 positions)*	0.004 (0.0002)
	Runout (with disc brake rotor attached to the vehicle)	0.040 (0.0016) or less

\* To check if rotor imbalance, rotor runout or rotor deformation exists.

### Rear Disc Brake

INFOID:0000000012894360

Unit: mm (in)

Item		Limit
Brake pad	Wear thickness	2 (0.079)
Disc brake rotor	Wear thickness	14 (0.551)
	Thickness variation (measured at 8 positions)*	0.010 (0.0004)
	Runout (with disc brake rotor attached to the vehicle)	0.05 (0.0020) or less

\* To check if rotor imbalance, rotor runout or rotor deformation exists.