

SECTION **BRC**

BRAKE CONTROL SYSTEM

A
B
C
D
E

CONTENTS

		BRC
WITHOUT ICC		
PRECAUTION	7	
PRECAUTIONS	7	
Precaution for Supplemental Restraint System (SRS) "AIR BAG" and "SEAT BELT PRE-TENSIONER"	7	
Precaution for Procedure without Cowl Top Cover.....	7	
Precaution for Brake System	7	
Precaution for Brake Control System	8	
Precaution for Harness Repair	8	
PREPARATION	9	
PREPARATION	9	
Special Service Tool	9	
Commercial Service Tools	9	
SYSTEM DESCRIPTION	10	
COMPONENT PARTS	10	
Component Parts Location	10	
Wheel Sensor and Sensor Rotor	11	
ABS Actuator and Electric Unit (Control Unit)	12	
Stop Lamp Switch	12	
Steering Angle Sensor	13	
Brake Fluid Level Switch	13	
Vacuum Sensor	13	
Parking Brake Switch	13	
VDC OFF Switch	13	
SYSTEM	15	
System Description	15	
Fail-Safe	25	
VDC FUNCTION	27	
VDC FUNCTION : System Description	28	
TCS FUNCTION	30	
TCS FUNCTION : System Description	30	
ABS FUNCTION	32	
	ABS FUNCTION : System Description	32
	EBD FUNCTION	33
	EBD FUNCTION : System Description	34
	BRAKE ASSIST FUNCTION	35
	BRAKE ASSIST FUNCTION : System Description	36
	HILL START ASSIST FUNCTION	37
	hill start assist FUNCTION : System Description	37
	WARNING/INDICATOR/CHIME LIST	38
	WARNING/INDICATOR/CHIME LIST : Warning Lamp/Indicator Lamp	38
	DIAGNOSIS SYSTEM [ABS ACTUATOR AND ELECTRIC UNIT (CONTROL UNIT)]	39
	CONSULT Function	39
	ECU DIAGNOSIS INFORMATION	44
	ABS ACTUATOR AND ELECTRIC UNIT (CONTROL UNIT)	44
	Reference Value	44
	Fail-Safe	47
	DTC Inspection Priority Chart	50
	DTC Index	51
	WIRING DIAGRAM	53
	BRAKE CONTROL SYSTEM	53
	Wiring Diagram	53
	BASIC INSPECTION	58
	DIAGNOSIS AND REPAIR WORK FLOW	58
	Work Flow	58
	Diagnostic Work Sheet	59
	ADDITIONAL SERVICE WHEN REPLACING ABS ACTUATOR AND ELECTRIC UNIT (CONTROL UNIT)	61

G
H
I
J
K
L
M
N
O

Description	61	C1121, C1123, C1125, C1127 ABS OUT VALVE SYSTEM	104
ADJUSTMENT OF STEERING ANGLE SENSOR NEUTRAL POSITION	62	DTC Description	104
Description	62	Diagnosis Procedure	105
Work Procedure	62	C1130 ENGINE SIGNAL	106
CALIBRATION OF DECEL G SENSOR	64	DTC Description	106
Description	64	Diagnosis Procedure	106
Work Procedure	64	C1140 ACTUATOR RELAY SYSTEM	108
CONFIGURATION [ABS ACTUATOR AND ELECTRIC UNIT (CONTROL UNIT)]	66	DTC Description	108
Work Procedure	66	Diagnosis Procedure	108
DTC/CIRCUIT DIAGNOSIS	68	C1142 PRESS SENSOR	110
C1101, C1102, C1103, C1104 WHEEL SENSOR	68	DTC Description	110
DTC Description	68	Diagnosis Procedure	110
Diagnosis Procedure	69	C1143 STEERING ANGLE SENSOR	113
C1105, C1106, C1107, C1108 WHEEL SENSOR	73	DTC Description	113
DTC Description	73	Diagnosis Procedure	113
Diagnosis Procedure	74	C1144 INCOMPLETE STEERING ANGLE SENSOR ADJUSTMENT	117
C1109 POWER AND GROUND SYSTEM	80	DTC Description	117
DTC Description	80	Diagnosis Procedure	117
Diagnosis Procedure	80	C1154 TRANSMISSION RANGE SWITCH	119
C1110, C1153 ABS ACTUATOR AND ELECTRIC UNIT (CONTROL UNIT)	82	DTC Description	119
DTC Description	82	Diagnosis Procedure	119
Diagnosis Procedure	83	C1155 BRAKE FLUID LEVEL SWITCH	121
C1111 ABS MOTOR, MOTOR RELAY SYSTEM	84	DTC Description	121
DTC Description	84	Diagnosis Procedure	121
Diagnosis Procedure	84	Component Inspection	124
C1113, C1145, C1146 YAW RATE/SIDE/DECEL G SENSOR	87	C1160 INCOMPLETE DECEL G SENSOR CALIBRATION	125
DTC Description	87	DTC Description	125
Diagnosis Procedure	88	Diagnosis Procedure	125
C1115 WHEEL SENSOR	89	C1164, C1165 CV SYSTEM	127
DTC Description	89	DTC Description	127
Diagnosis Procedure	89	Diagnosis Procedure	127
C1116 STOP LAMP SWITCH	96	C1166, C1167 SV SYSTEM	129
DTC Description	96	DTC Description	129
Diagnosis Procedure	97	Diagnosis Procedure	129
Component Inspection	100	C1170 VARIANT CODING	131
C1120, C1122, C1124, C1126 ABS IN VALVE SYSTEM	102	DTC Description	131
DTC Description	102	Diagnosis Procedure	131
Diagnosis Procedure	103	C1197 VACUUM SENSOR	133
C1121, C1123, C1125, C1127 ABS OUT VALVE SYSTEM	104	DTC Description	133
DTC Description	104	Diagnosis Procedure	133
Diagnosis Procedure	105	C1198 VACUUM SENSOR	136
C1130 ENGINE SIGNAL	106	DTC Description	136
DTC Description	106	Diagnosis Procedure	136
Diagnosis Procedure	106	C1199 BRAKE BOOSTER	138
C1140 ACTUATOR RELAY SYSTEM	108	DTC Description	138
DTC Description	108		
Diagnosis Procedure	108		
C1142 PRESS SENSOR	110		
DTC Description	110		
Diagnosis Procedure	110		
C1143 STEERING ANGLE SENSOR	113		
DTC Description	113		
Diagnosis Procedure	113		
C1144 INCOMPLETE STEERING ANGLE SENSOR ADJUSTMENT	117		
DTC Description	117		
Diagnosis Procedure	117		
C1154 TRANSMISSION RANGE SWITCH	119		
DTC Description	119		
Diagnosis Procedure	119		
C1155 BRAKE FLUID LEVEL SWITCH	121		
DTC Description	121		
Diagnosis Procedure	121		
Component Inspection	124		
C1160 INCOMPLETE DECEL G SENSOR CALIBRATION	125		
DTC Description	125		
Diagnosis Procedure	125		
C1164, C1165 CV SYSTEM	127		
DTC Description	127		
Diagnosis Procedure	127		
C1166, C1167 SV SYSTEM	129		
DTC Description	129		
Diagnosis Procedure	129		
C1170 VARIANT CODING	131		
DTC Description	131		
Diagnosis Procedure	131		
C1197 VACUUM SENSOR	133		
DTC Description	133		
Diagnosis Procedure	133		
C1198 VACUUM SENSOR	136		
DTC Description	136		
Diagnosis Procedure	136		
C1199 BRAKE BOOSTER	138		
DTC Description	138		

Special Service Tool	179	DIAGNOSIS SYSTEM [ABS ACTUATOR AND ELECTRIC UNIT (CONTROL UNIT)]	213
Commercial Service Tools	179	CONSULT Function	213
SYSTEM DESCRIPTION	180	DIAGNOSIS SYSTEM (ICC SENSOR)	218
COMPONENT PARTS	180	CONSULT Function (LASER/RADAR)	218
Component Parts Location	180	ECU DIAGNOSIS INFORMATION	222
Wheel Sensor and Sensor Rotor	182	ABS ACTUATOR AND ELECTRIC UNIT (CONTROL UNIT)	222
ABS Actuator and Electric Unit (Control Unit)	182	Reference Value	222
Stop Lamp Switch	183	Fail-Safe	225
Steering Angle Sensor	183	DTC Inspection Priority Chart	227
Brake Fluid Level Switch	184	DTC Index	228
Vacuum Sensor	184	ADAS CONTROL UNIT	230
Parking Brake Switch	184	Reference Value	230
VDC OFF Switch	184	Fail-safe (ADAS Control Unit)	234
ADAS Control Unit	185	DTC Inspection Priority Chart	235
ICC Sensor	185	DTC Index	235
Brake Pedal Position Switch / Stop Lamp Switch	185	WIRING DIAGRAM	237
ICC Brake Hold Relay	186	BRAKE CONTROL SYSTEM	237
Warning Buzzer	186	Wiring Diagram	237
SYSTEM	187	BASIC INSPECTION	242
System Description	187	DIAGNOSIS AND REPAIR WORK FLOW	242
Fail-Safe	195	Work Flow	242
VDC FUNCTION	197	Diagnostic Work Sheet	243
VDC FUNCTION : System Description	197	ADDITIONAL SERVICE WHEN REPLACING ABS ACTUATOR AND ELECTRIC UNIT (CONTROL UNIT)	245
TCS FUNCTION	199	Description	245
TCS FUNCTION : System Description	200	ADDITIONAL SERVICE WHEN REPLACING ICC SENSOR	246
ABS FUNCTION	201	Description	246
ABS FUNCTION : System Description	202	Work Procedure	246
EBD FUNCTION	203	ADJUSTMENT OF STEERING ANGLE SENSOR NEUTRAL POSITION	247
EBD FUNCTION : System Description	203	Description	247
BRAKE ASSIST (WITHOUT PREVIEW FUNCTION)	204	Work Procedure	247
BRAKE ASSIST (WITHOUT PREVIEW FUNCTION) : System Description	205	CALIBRATION OF DECEL G SENSOR	249
HILL START ASSIST FUNCTION	206	Description	249
hill start assist FUNCTION : System Description	206	Work Procedure	249
BRAKE ASSIST (WITH PREVIEW FUNCTION)	207	CONFIGURATION [ABS ACTUATOR AND ELECTRIC UNIT (CONTROL UNIT)]	251
BRAKE ASSIST (WITH PREVIEW FUNCTION) : System Description-Forward Emergency Braking	207	Work Procedure	251
BRAKE ASSIST (WITH PREVIEW FUNCTION) : Fail-safe (ICC RADAR)	209	ICC SENSOR INITIAL VERTICAL ALIGNMENT	253
WARNING/INDICATOR/CHIME LIST	209	Description	253
WARNING/INDICATOR/CHIME LIST : Warning Lamp/Indicator Lamp	209	Required Tools	253
OPERATION	210	Preparation	253
Switch Name and Function	210		
Menu Displayed by Pressing Each Switch	210		
HANDLING PRECAUTION	212		
Description	212		

ICC Sensor Initial Vertical Alignment	254	DTC Description	299	
		Diagnosis Procedure	300	A
ICC SENSOR ALIGNMENT	255	C1130 ENGINE SIGNAL	301	
Description	255	DTC Description	301	B
Required Tools	255	Diagnosis Procedure	301	
Preparation	256	C1140 ACTUATOR RELAY SYSTEM	303	
Vehicle Set Up	257	DTC Description	303	C
Setting The ICC Target Board	259	Diagnosis Procedure	303	
ICC Sensor Adjustment	260	C1142 PRESS SENSOR	305	
ACTION TEST	262	DTC Description	305	D
Description	262	Diagnosis Procedure	305	
Inspection Procedure	262	C1143 STEERING ANGLE SENSOR	308	
DTC/CIRCUIT DIAGNOSIS	263	DTC Description	308	E
C1101, C1102, C1103, C1104 WHEEL SEN- SOR	263	Diagnosis Procedure	308	
DTC Description	263	C1144 INCOMPLETE STEERING ANGLE SENSOR ADJUSTMENT	312	BRC
Diagnosis Procedure	264	DTC Description	312	
C1105, C1106, C1107, C1108 WHEEL SEN- SOR	268	Diagnosis Procedure	312	G
DTC Description	268	C1154 TRANSMISSION RANGE SWITCH	314	
Diagnosis Procedure	269	DTC Description	314	H
C1109 POWER AND GROUND SYSTEM	275	Diagnosis Procedure	314	
DTC Description	275	C1155 BRAKE FLUID LEVEL SWITCH	316	
Diagnosis Procedure	275	DTC Description	316	I
C1110, C1153 ABS ACTUATOR AND ELEC- TRIC UNIT (CONTROL UNIT)	277	Diagnosis Procedure	316	
DTC Description	277	Component Inspection	319	J
Diagnosis Procedure	278	C1160 INCOMPLETE DECEL G SENSOR CALIBRATION	320	
C1111 ABS MOTOR, MOTOR RELAY SYS- TEM	279	DTC Description	320	K
DTC Description	279	Diagnosis Procedure	320	
Diagnosis Procedure	279	C1164, C1165 CV SYSTEM	322	
C1113, C1145, C1146 YAW RATE/SIDE/DE- CEL G SENSOR	282	DTC Description	322	L
DTC Description	282	Diagnosis Procedure	322	
Diagnosis Procedure	283	C1166, C1167 SV SYSTEM	324	
C1115 WHEEL SENSOR	284	DTC Description	324	M
DTC Description	284	Diagnosis Procedure	324	
Diagnosis Procedure	284	C1170 VARIANT CODING	326	
C1116 STOP LAMP SWITCH	291	DTC Description	326	N
DTC Description	291	Diagnosis Procedure	326	
Diagnosis Procedure	292	C1197 VACUUM SENSOR	328	
Component Inspection	296	DTC Description	328	O
C1120, C1122, C1124, C1126 ABS IN VALVE SYSTEM	297	Diagnosis Procedure	328	
DTC Description	297	C1198 VACUUM SENSOR	331	
Diagnosis Procedure	298	DTC Description	331	P
C1121, C1123, C1125, C1127 ABS OUT VALVE SYSTEM	299	Diagnosis Procedure	331	
		C1199 BRAKE BOOSTER	333	
		DTC Description	333	
		Diagnosis Procedure	333	

C119A VACUUM SENSOR	336	UNEXPECTED BRAKE PEDAL REACTION ..	359
DTC Description	336	Description	359
Diagnosis Procedure	336	Diagnosis Procedure	359
U1000 CAN COMM CIRCUIT	339	THE BRAKING DISTANCE IS LONG	360
DTC Description	339	Description	360
Diagnosis Procedure	339	Diagnosis Procedure	360
U1002 SYSTEM COMM (CAN)	340	DOES NOT OPERATE	361
DTC Description	340	Description	361
Diagnosis Procedure	340	Diagnosis Procedure	361
POWER SUPPLY AND GROUND CIRCUIT ..	342	BRAKE PEDAL VIBRATION OR OPERA-	
Diagnosis Procedure	342	TION SOUND OCCURS	362
PARKING BRAKE SWITCH	343	Description	362
Component Function Check	343	Diagnosis Procedure	362
Diagnosis Procedure	343	VEHICLE JERKS DURING	363
Component Inspection	344	Description	363
VDC OFF SWITCH	345	Diagnosis Procedure	363
Component Function Check	345	NORMAL OPERATING CONDITION	364
Diagnosis Procedure	345	Description	364
Component Inspection	346	REMOVAL AND INSTALLATION	365
ABS WARNING LAMP	347	WHEEL SENSOR	365
Component Function Check	347	FRONT WHEEL SENSOR	365
Diagnosis Procedure	347	FRONT WHEEL SENSOR : Exploded View	365
BRAKE WARNING LAMP	348	FRONT WHEEL SENSOR : Removal and Instal-	
Component Function Check	348	lation	365
Diagnosis Procedure	348	REAR WHEEL SENSOR	366
VDC WARNING LAMP	350	REAR WHEEL SENSOR : Exploded View	366
Component Function Check	350	REAR WHEEL SENSOR : Removal and Installa-	
Diagnosis Procedure	350	tion	367
VDC OFF INDICATOR LAMP	351	SENSOR ROTOR	369
Component Function Check	351	FRONT SENSOR ROTOR	369
Diagnosis Procedure	351	FRONT SENSOR ROTOR : Removal and Instal-	
FORWARD EMERGENCY BRAKING	352	lation - Front Sensor Rotor	369
Diagnosis Procedure	352	REAR SENSOR ROTOR	369
SYMPTOM DIAGNOSIS	353	REAR SENSOR ROTOR : Removal and Installa-	
DRIVER ASSISTANCE SYSTEM SYMP-		tion - Rear Sensor Rotor	369
TOMS	353	ABS ACTUATOR AND ELECTRIC UNIT	
Symptom Table	353	(CONTROL UNIT)	370
SYSTEM SETTINGS CANNOT BE TURNED		Exploded View	370
ON/OFF ON THE INTEGRAL SWITCH	354	Removal and Installation	370
Symptom Table	354	VDC OFF SWITCH	372
Description	354	Exploded View	372
Diagnosis Procedure	354	Removal and Installation	372
EXCESSIVE OPERATION FREQUENCY	357	STEERING ANGLE SENSOR	373
Description	357	Exploded View	373
Diagnosis Procedure	357	Removal and Installation	373

PRECAUTION

PRECAUTIONS

Precaution for Supplemental Restraint System (SRS) "AIR BAG" and "SEAT BELT PRE-TENSIONER"

INFOID:000000012894375

The Supplemental Restraint System such as "AIR BAG" and "SEAT BELT PRE-TENSIONER", used along with a front seat belt, helps to reduce the risk or severity of injury to the driver and front passenger for certain types of collision. Information necessary to service the system safely is included in the SR and SB section of this Service Manual.

WARNING:

- To avoid rendering the SRS inoperative, which could increase the risk of personal injury or death in the event of a collision which would result in air bag inflation, it is recommended that all maintenance and repair be performed by an authorized NISSAN/INFINITI dealer.
- Improper repair, including incorrect removal and installation of the SRS, can lead to personal injury caused by unintentional activation of the system. For removal of Spiral Cable and Air Bag Module, see the SR section.
- Do not use electrical test equipment on any circuit related to the SRS unless instructed to in this Service Manual. SRS wiring harnesses can be identified by yellow and/or orange harnesses or harness connectors.

PRECAUTIONS WHEN USING POWER TOOLS (AIR OR ELECTRIC) AND HAMMERS

WARNING:

- When working near the Air Bag Diagnosis Sensor Unit or other Air Bag System sensors with the Ignition ON or engine running, DO NOT use air or electric power tools or strike near the sensor(s) with a hammer. Heavy vibration could activate the sensor(s) and deploy the air bag(s), possibly causing serious injury.
- When using air or electric power tools or hammers, always switch the Ignition OFF, disconnect the battery or batteries, and wait at least three minutes before performing any service.

Precaution for Procedure without Cowl Top Cover

INFOID:000000012894376

When performing the procedure after removing cowl top cover, cover the lower end of windshield with urethane, etc. to prevent damage to windshield.

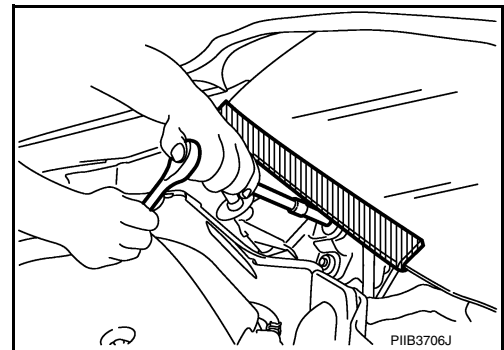

Precaution for Brake System

INFOID:000000012894377

WARNING:

Clean any dust from the front brake and rear brake using a vacuum dust collector. Do not blow by compressed air.

- Brake fluid use refer to [MA-12. "Fluids and Lubricants"](#).
- Do not reuse drained brake fluid.
- Do not spill or splash brake fluid on painted surfaces. Brake fluid may seriously damage paint. Wipe it off immediately and wash with water if it gets on a painted surface.
- Always confirm the specified tightening torque when installing the brake pipes.
- After pressing the brake pedal more deeply or harder than normal driving, such as air bleeding, check each item of brake pedal. Adjust brake pedal if it is outside the standard value.
- Do not use mineral oils such as gasoline or light oil to clean. They may damage rubber parts and cause improper operation.
- Always loosen the brake tube flare nut with a flare nut wrench.

A
B
C
D
E
BRC
G
H
I
J
K
L
M
N
O
P

PRECAUTIONS

< PRECAUTION >

[WITHOUT ICC]

- Tighten the brake tube flare nut to the specified torque with a flare nut crowfoot (A) and torque wrench (B).
- Always connect the battery terminal when moving the vehicle.
- Turn the ignition switch OFF and disconnect the ABS actuator and electric unit (control unit) harness connector or the battery negative terminal before performing the work.
- Check that no brake fluid leakage is present after replacing the parts.

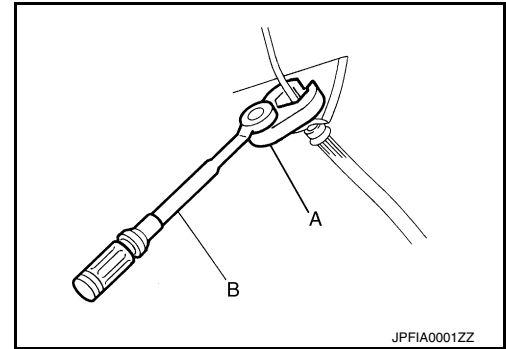

Precaution for Brake Control System

INFOID:0000000012894378

- Just after starting vehicle after ignition switch is ON, brake pedal may vibrate or motor operating noise may be heard from engine compartment. This is a normal condition.
- When an error is indicated by ABS or another warning lamp, collect all necessary information from customer (what symptoms are present under what conditions) and check for simple causes before starting diagnostic servicing. Besides electrical system inspection, check brake booster operation, brake fluid level and oil leaks.
- If tire size and type are used in an improper combination or brake pads are not Genuine NISSAN parts, stopping distance or steering stability may deteriorate.
- ABS might be out of order or malfunctions by putting a radio (wiring inclusive), an antenna and a lead-in wire near the control unit.
- If aftermarket parts (car stereo, CD player, etc.) have been installed, check for incidents such as harness pinches, open circuits, and improper wiring.
- VDC system may not operate normally or a VDC OFF indicator lamp or SLIP indicator lamp may light.
- When replacing the following parts with parts other than genuine parts or making modifications: Suspension-related parts (shock absorber, spring, bushing, etc.), tires, wheels (other than specified sizes), brake-related parts (pad, rotor, caliper, etc.), engine-related parts (muffler, ECM, etc.) and body reinforcement-related parts (roll bar, tower bar, etc.).
- When driving with worn or deteriorated suspension, tires and brake-related parts.

Precaution for Harness Repair

INFOID:0000000012894379

- Solder the repair part, and wrap it with tape. [Twisted wire fray must be 110 mm (4.33 in) or less.]

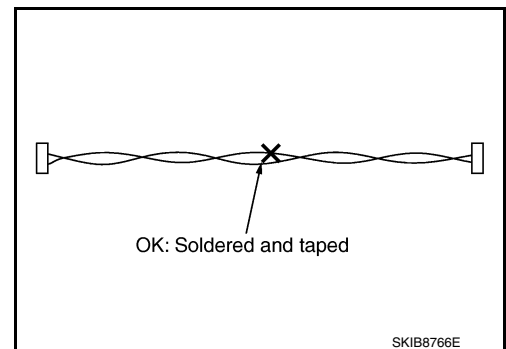

- Do not bypass the repair point with wire. (If it is bypassed, the turn-out point cannot be separated and the twisted wire characteristics are lost.)

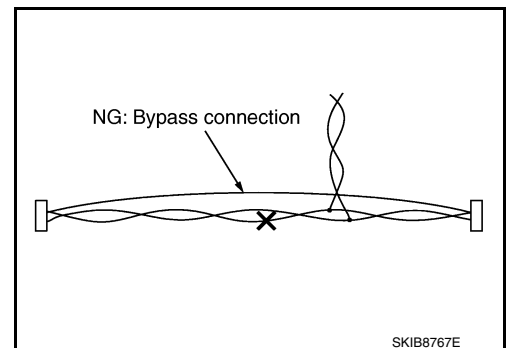

PREPARATION

< PREPARATION >

[WITHOUT ICC]

PREPARATION

PREPARATION

Special Service Tool

INFOID:0000000012894380

The actual shape of the tools may differ from those illustrated here.

Tool number (TechMate No.) Tool name	Description
KV991J0080 (J-45741) ABS active wheel sensor tester	Checking operation of ABS active wheel sensors

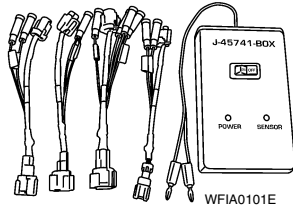

Commercial Service Tools

INFOID:0000000012894381

Tool name	Description
1. Flare nut crowfoot 2. Torque wrench	Tightening brake tube flare nuts a: 10 mm (0.39 in)/12 mm (0.47 in)
Power tool	Loosening nuts, screws and bolts

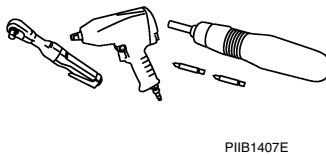
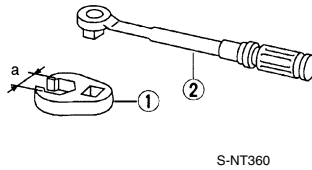

A
B
C
D
E
BRC
G
H
I
J
K
L
M
N
O
P

COMPONENT PARTS

< SYSTEM DESCRIPTION >

[WITHOUT ICC]

SYSTEM DESCRIPTION

COMPONENT PARTS

Component Parts Location

INFOID:000000012894382

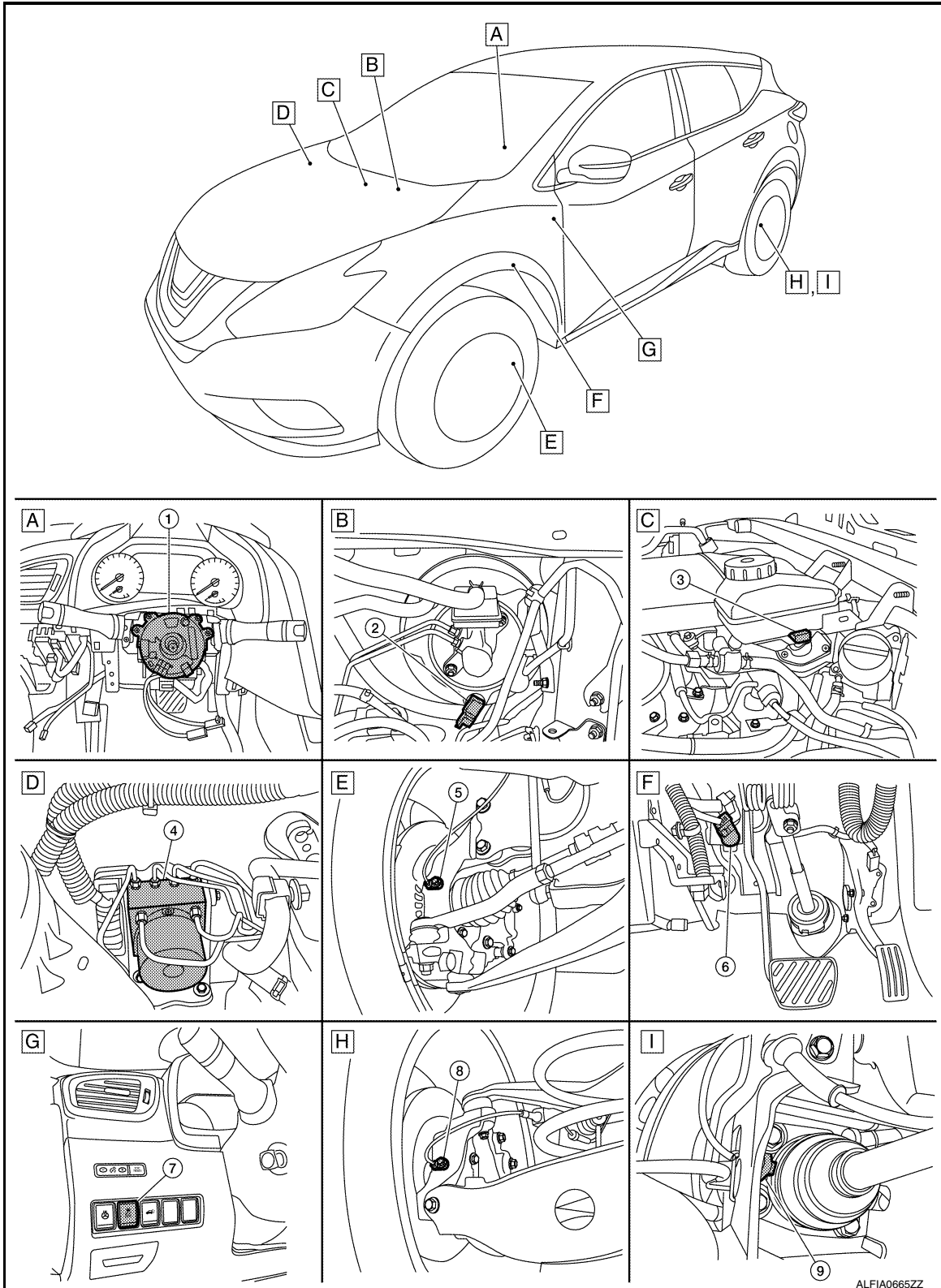

COMPONENT PARTS

< SYSTEM DESCRIPTION >

[WITHOUT ICC]

- | | | | |
|---|--------------------------------------|--------------------------------------|---|
| A. Steering column (view with steering wheel removed) | B. Engine room left side | C. Engine room left side | A |
| D. Engine room right side | E. Right front wheel area | F. Brake pedal area | B |
| G. Left side of instrument panel | H. Left rear wheel area (FWD models) | I. Left rear wheel area (AWD models) | C |

No.	Component parts	Function
1.	Steering angle sensor	BRC-13, "Steering Angle Sensor"
2.	Vacuum sensor	BRC-13, "Vacuum Sensor"
3.	Brake fluid level switch	BRC-13, "Brake Fluid Level Switch"
4.	ABS actuator and electric unit (control unit)	BRC-12, "ABS Actuator and Electric Unit (Control Unit)"
5.	Front LH wheel sensor	BRC-11, "Wheel Sensor and Sensor Rotor"
6.	Stop lamp switch	BRC-13, "Parking Brake Switch"
7.	VDC OFF switch	BRC-13, "VDC OFF Switch"
8.	Rear LH wheel sensor (FWD models)	BRC-11, "Wheel Sensor and Sensor Rotor"
9.	Rear LH wheel sensor (AWD models)	BRC-11, "Wheel Sensor and Sensor Rotor"

Wheel Sensor and Sensor Rotor

INFOID:000000012894383

NOTE:

- Wheel sensor of front wheel is installed on steering knuckle.
- Sensor rotor of front wheel is integrated into the wheel hub assembly.
- Wheel sensor of rear wheel is installed on rear final drive.
- Sensor rotor of rear wheel is installed on drive shaft (rear final drive side).
- Never measure resistance and voltage value using a tester because sensor is an active sensor.

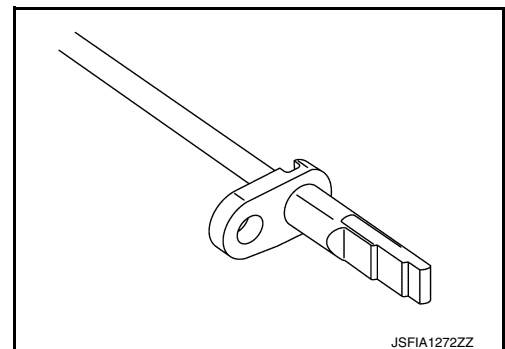

- Power supply is supplied to detection portion so that magnetic field line is read. Magnetic field that is detected is converted to current signal.
- When sensor rotor rotates, magnetic field changes. Magnetic field change is converted to current signals (rectangular wave) and is transmitted to ABS actuator and electric unit (control unit). Change of magnetic field is proportional to wheel speed.

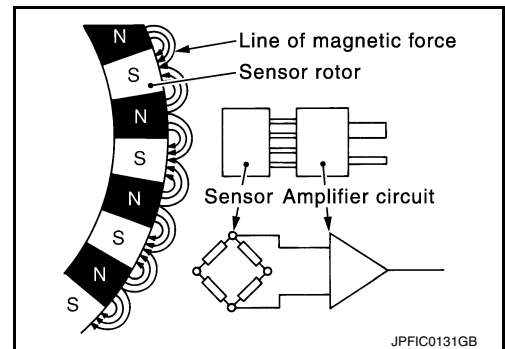

COMPONENT PARTS

< SYSTEM DESCRIPTION >

[WITHOUT ICC]

ABS Actuator and Electric Unit (Control Unit)

INFOID:000000012894384

Electric unit (control unit) is integrated with actuator and comprehensively controls VDC function, TCS function, ABS function, EBD function, brake assist function and hill start assist function.

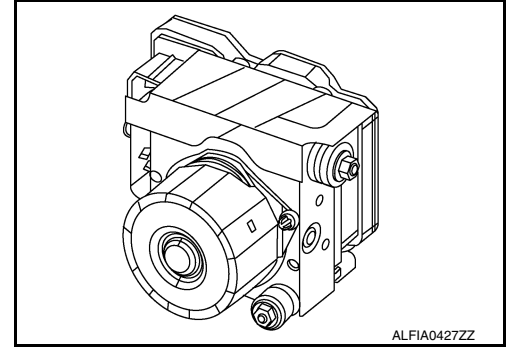

ELECTRIC UNIT (CONTROL UNIT)

- Brake fluid pressure, engine and transmission are controlled according to signals from each sensor.
- If malfunction is detected, the system enters fail-safe mode.

ACTUATOR

The following components are integrated with ABS actuator:

Pump

Returns the brake fluid reserved in reservoir to master cylinder by reducing pressure.

Motor

Activates the pump according to signals from ABS actuator and electric unit (control unit).

Motor Relay

Operates the motor ON/OFF according to signals from ABS actuator and electric unit (control unit).

Actuator Relay

Operates each valve ON/OFF according to signals from ABS actuator and electric unit (control unit).

ABS IN Valve and ABS OUT Valve

Increases, holds or decreases the fluid pressure of each caliper according to signals from ABS actuator and electric unit (control unit).

Pressure Sensor

Detects the brake fluid pressure and transmits signal to ABS actuator and electric unit (control unit).

Cut Valve 1 (Primary Line), Cut Valve 2 (Secondary Line)

Shuts off the ordinary brake line from master cylinder when VDC function, TCS function, brake assist function, hill start assist function are activated.

Yaw Rate/Side/Decel G Sensor

Calculates the following information that affects the vehicle and transmits a signal to ABS actuator and electric unit (control unit). [Yaw rate/side/decel G sensor is integrated into the ABS actuator and electric unit (control unit).]

- Vehicle rotation angular velocity (yaw rate signal)
- Vehicle lateral acceleration (side G signal)
- Vehicle longitudinal acceleration (decel G signal)

Stop Lamp Switch

INFOID:000000012894385

Detects the operation status of brake pedal and transmits converted electric signal to ABS actuator and electric unit (control unit).

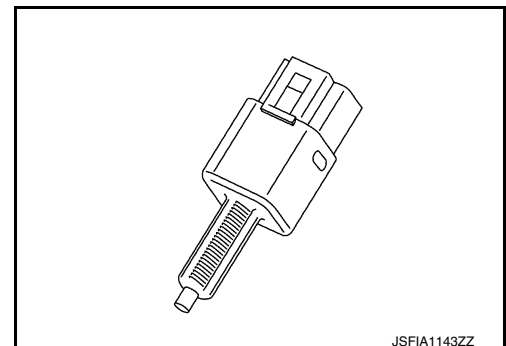

Steering Angle Sensor

INFOID:000000012894386

Detects the following information and transmits steering angle signal to ABS actuator and electric unit (control unit) via CAN communication:

- Steering angle sensor malfunction signal
- Steering wheel rotation amount
- Steering wheel rotation angular velocity
- Steering wheel rotation direction

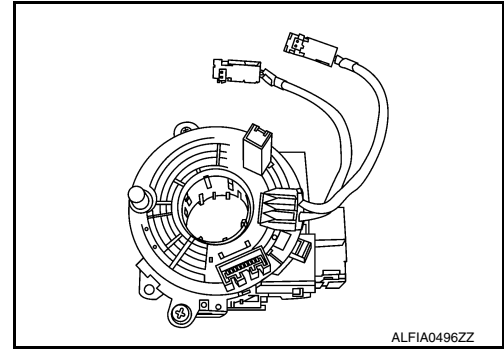

Brake Fluid Level Switch

INFOID:000000012894387

Detects the brake fluid level in reservoir tank and transmits converted electric signal from combination meter to ABS actuator and electric unit (control unit) via CAN communication when brake fluid level is the specified level or less.

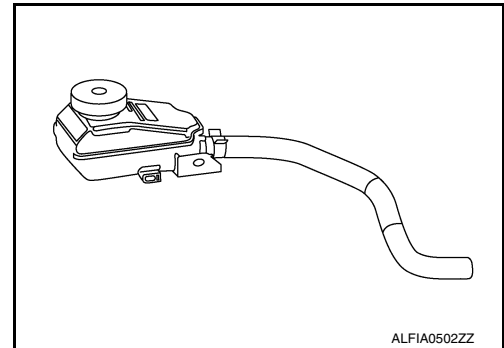

Vacuum Sensor

INFOID:000000012894388

Detects the vacuum in brake booster and transmits converted electric signal to ABS actuator and electric unit (control unit).

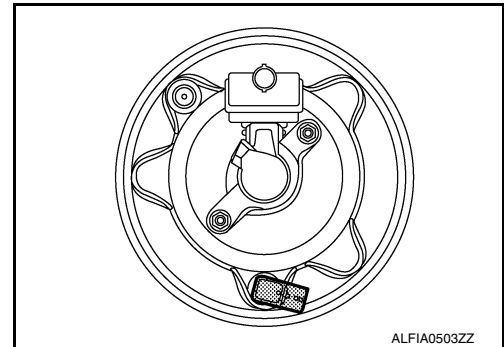

Parking Brake Switch

INFOID:000000012894389

Detects the operation status of parking brake switch and transmits converted electric signal from combination meter to ABS actuator and electric unit (control unit).

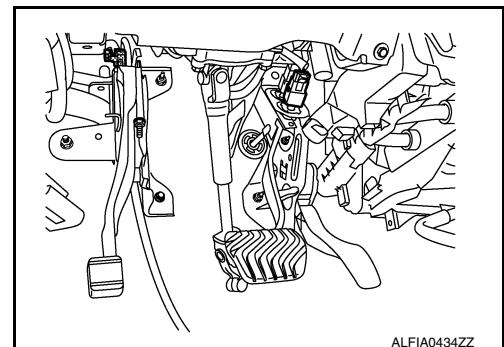

VDC OFF Switch

INFOID:000000012894390

- This is an integrated switch with switches for other functions.

A
B
C
D
E
BRC
G
H
I
J
K
L
M
N
O
P

COMPONENT PARTS

< SYSTEM DESCRIPTION >

[WITHOUT ICC]

- Non-operational status or standby status of the following functions can be selected using VDC OFF switch. VDC OFF indicator lamp indicates the operation status of function (ON: Non-operational status, OFF: Standby status).
- Vehicle Dynamic Control function
- Traction Control System function
- Forward Emergency Braking function

NOTE:

ABS function, EBD function operate.

- VDC OFF indicator lamp turns OFF (standby status) when the engine is started again after it is stopped once while VDC OFF indicator lamp is ON (non-operational status).

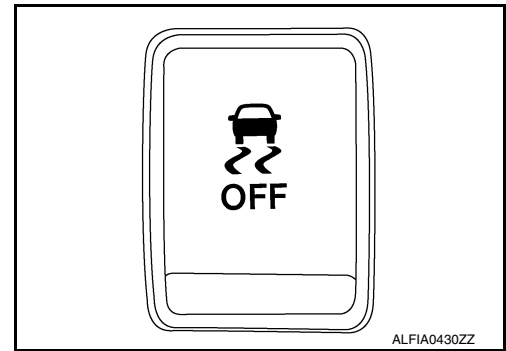

SYSTEM

System Description

INFOID:000000012894391

SYSTEM DIAGRAM

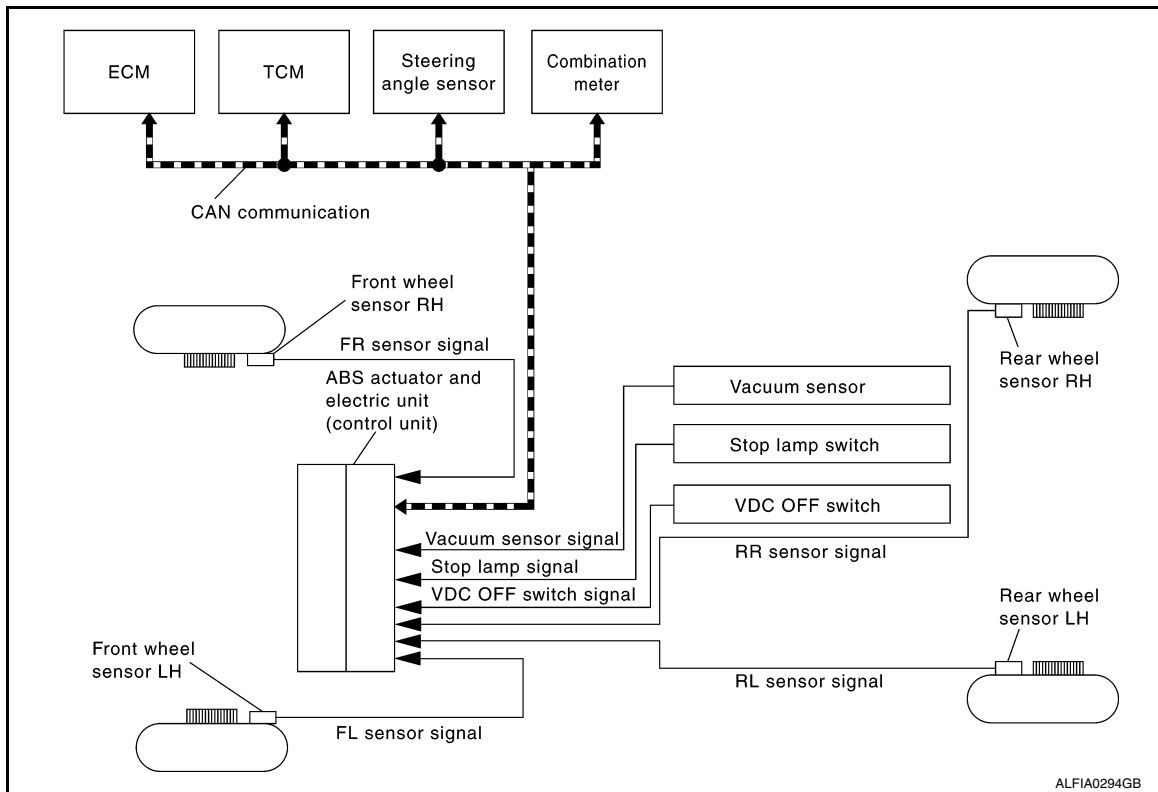

- The system switches fluid pressure of each brake caliper to increase, to hold, or to decrease according to signals from control unit in ABS actuator and electric unit (control unit). This control system is applied to VDC, TCS, ABS and EBD, hill start and brake assist functions.
- Fail-safe function is available for each function and is activated by each function when system malfunction occurs.

INPUT SIGNAL AND OUTPUT SIGNAL

Major signal transmission between each unit via communication lines is shown in the following table.

Component	Signal description
Steering angle sensor	Transmits the steering angle sensor signal to ABS actuator and electric unit (control unit) via CAN communication.
ECM	Transmits the following signals to ABS actuator and electric unit (control unit) via CAN communication. <ul style="list-style-type: none"> • Accelerator pedal position signal • Engine speed signal • Target throttle position signal
TCM	Transmits the current gear position signal to ABS actuator and electric unit (control unit) via CAN communication.
Combination meter	Transmits the following signals to ABS actuator and electric unit (control unit) via CAN communication. <ul style="list-style-type: none"> • Brake fluid level switch signal • Parking brake switch signal Receives the following signals from ABS actuator and electric unit (control unit) via CAN communication. <ul style="list-style-type: none"> • ABS warning lamp signal • Brake warning lamp signal • VDC OFF indicator lamp signal • Slip indicator lamp signal

A
B
C
D
E
BRC
G
H
I
J
K
L
M
N
O
P

SYSTEM

< SYSTEM DESCRIPTION >

[WITHOUT ICC]

VALVE OPERATION (VDC AND TCS FUNCTIONS)

The control unit built in the ABS actuator and electric unit (control unit) controls fluid pressure of the brake calipers by operating each valve.

VDC and TCS Functions are Operating (Pressure Increases)

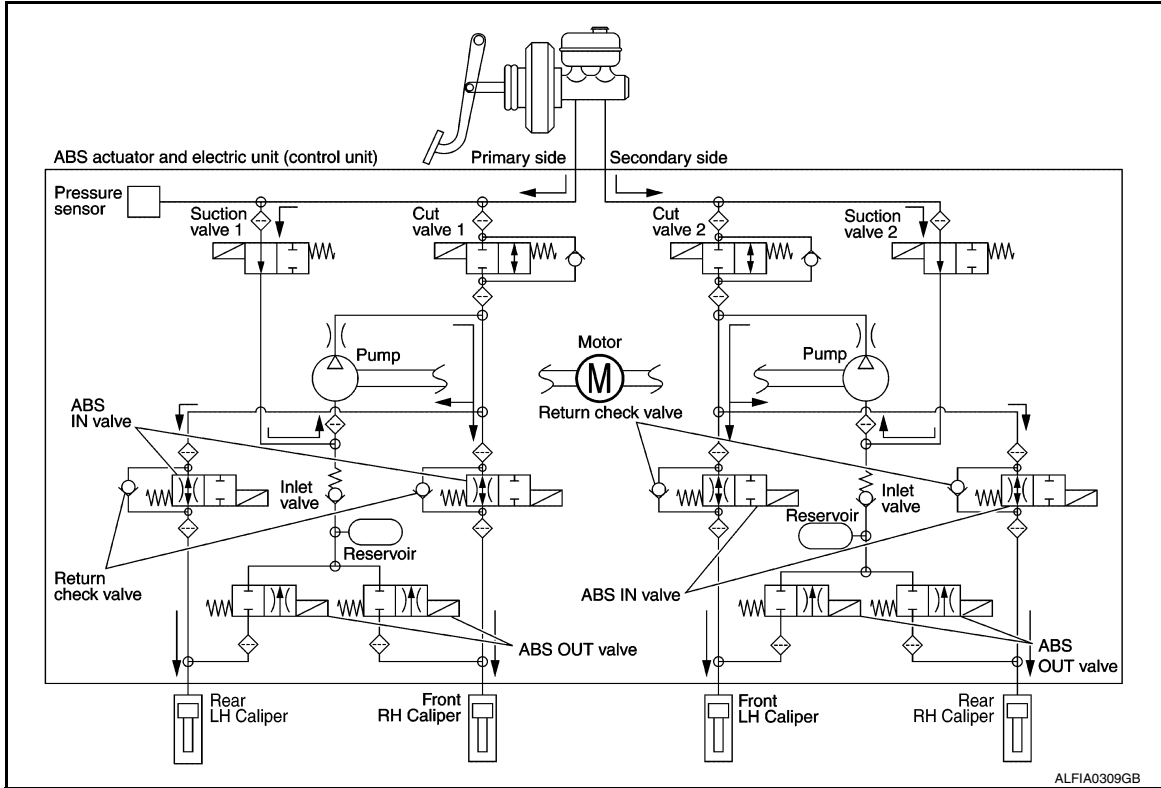

Name	Not activated	Pressure increases
Cut valve 1	Power supply is not supplied (open)	Power supply is supplied (close)
Cut valve 2	Power supply is not supplied (open)	Power supply is supplied (close)
Suction valve 1	Power supply is not supplied (close)	Power supply is supplied (open)
Suction valve 2	Power supply is not supplied (close)	Power supply is supplied (open)
ABS IN valve	Power supply is not supplied (open)	Power supply is not supplied (open)
ABS OUT valve	Power supply is not supplied (close)	Power supply is not supplied (close)
Each brake caliper (fluid pressure)	—	Pressure increases

Front RH brake caliper

- Brake fluid is conveyed to the pump from the master cylinder through suction valve 1 and is pressurized by the pump operation. The pressurized brake fluid is supplied to the front RH brake caliper through the ABS IN valve. For the left caliper, brake fluid pressure is maintained because the pressurization is unnecessary. The pressurization for the left caliper is controlled separately from the right caliper.

Front LH brake caliper

- Brake fluid is conveyed to the pump from the master cylinder through suction valve 2 and is pressurized by the pump operation. The pressurized brake fluid is supplied to the front LH brake caliper through the ABS IN valve. For the right caliper, brake fluid pressure is maintained because the pressurization is unnecessary. The pressurization for the right caliper is controlled separately from the left caliper.

Rear RH brake caliper

- Brake fluid is conveyed to the pump from the master cylinder through suction valve 2 and is pressurized by the pump operation. The pressurized brake fluid is supplied to the rear RH brake caliper through the ABS IN valve. For the left caliper, brake fluid pressure is maintained because the pressurization is unnecessary. The pressurization for the left caliper is controlled separately from the right caliper.

SYSTEM

< SYSTEM DESCRIPTION >

[WITHOUT ICC]

Rear LH brake caliper

- Brake fluid is conveyed to the pump from the master cylinder through suction valve 1 and is pressurized by the pump operation. The pressurized brake fluid is supplied to the rear LH brake caliper through the ABS IN valve. For the right caliper, brake fluid pressure is maintained because the pressurization is unnecessary. The pressurization for the right caliper is controlled separately from the left caliper.

VDC and TCS Functions Start Operating (Pressure Holds)

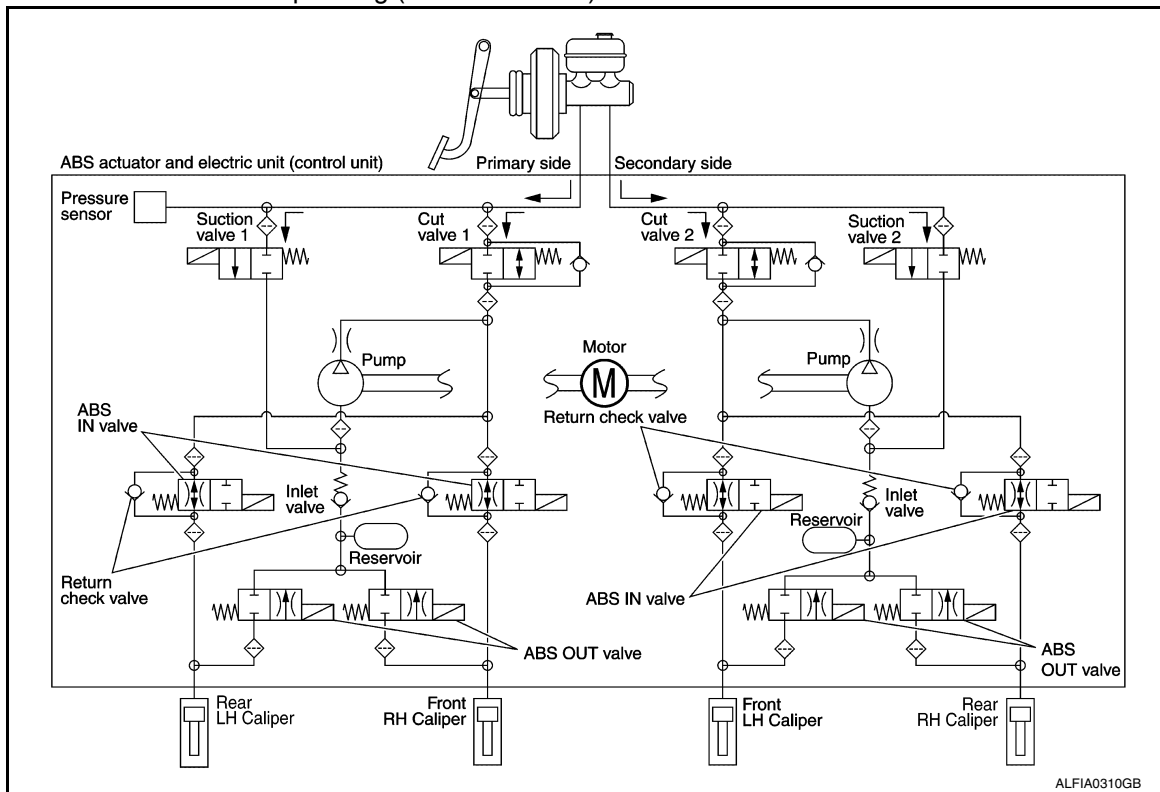

Name	Not activated	Pressure holds
Cut valve 1	Power supply is not supplied (open)	Power supply is supplied (close)
Cut valve 2	Power supply is not supplied (open)	Power supply is supplied (close)
Suction valve 1	Power supply is not supplied (close)	Power supply is not supplied (close)
Suction valve 2	Power supply is not supplied (close)	Power supply is not supplied (close)
ABS IN valve	Power supply is not supplied (open)	Power supply is not supplied (open)
ABS OUT valve	Power supply is not supplied (close)	Power supply is not supplied (close)
Each brake caliper (fluid pressure)	—	Pressure holds

Front RH brake caliper

- Since the cut valve 1 and the suction valve 1 are closed, the front RH brake caliper, master cylinder, and reservoir are blocked. This maintains fluid pressure applied on the front RH brake caliper. The pressurization for the left caliper is controlled separately from the right caliper.

Front LH brake caliper

- Since the cut valve 2 and the suction valve 2 are closed, the front LH brake caliper, master cylinder, and reservoir are blocked. This maintains fluid pressure applied on the front LH brake caliper. The pressurization for the right caliper is controlled separately from the left caliper.

Rear RH brake caliper

- Since the cut valve 2 and the suction valve 2 are closed, the rear RH brake caliper, master cylinder, and reservoir are blocked. This maintains fluid pressure applied on the rear RH brake caliper. The pressurization for the left caliper is controlled separately from the right caliper.

Rear LH brake caliper

SYSTEM

< SYSTEM DESCRIPTION >

[WITHOUT ICC]

- Since the cut valve 1 and the suction valve 1 are closed, the rear LH brake caliper, master cylinder, and reservoir are blocked. This maintains fluid pressure applied on the rear LH brake caliper. The pressurization for the right caliper is controlled separately from the left caliper.

VDC and TCS Functions Operating (Pressure Decreases)

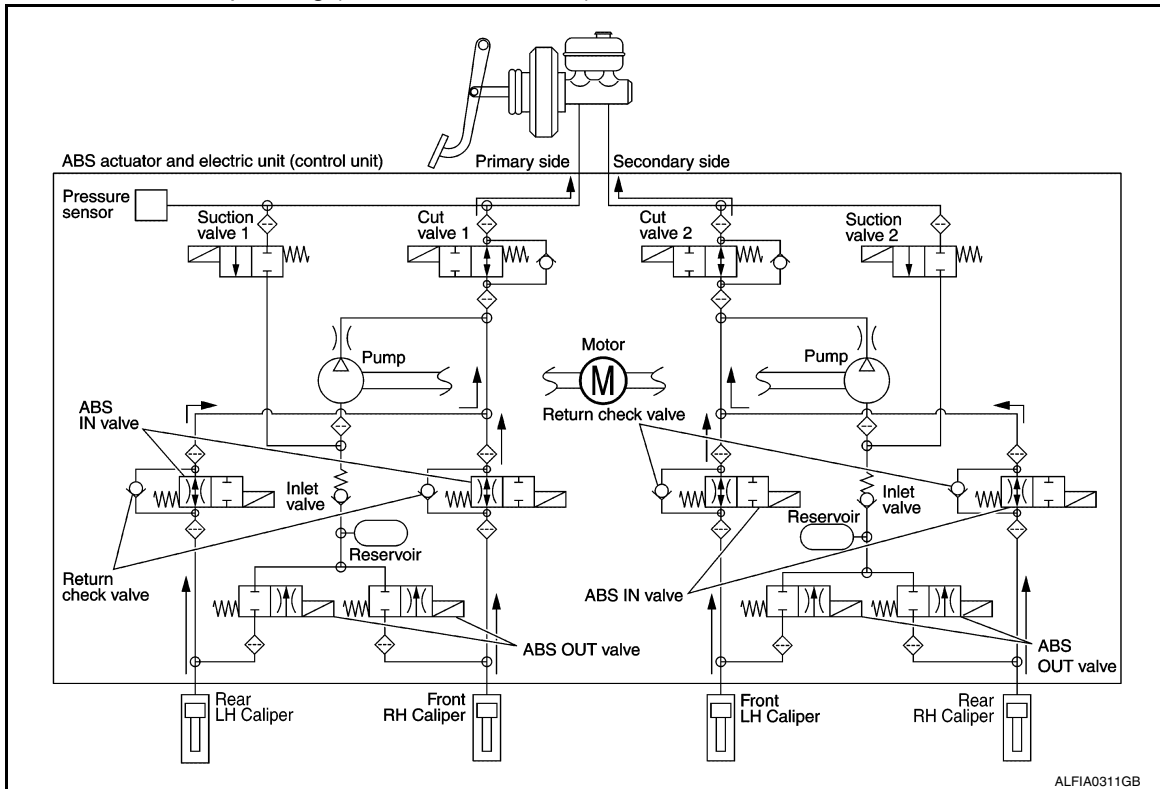

Name	Not activated	During pressure decreases
Cut valve 1	Power supply is not supplied (open)	Power supply is not supplied (open)
Cut valve 2	Power supply is not supplied (open)	Power supply is not supplied (open)
Suction valve 1	Power supply is not supplied (close)	Power supply is not supplied (close)
Suction valve 2	Power supply is not supplied (close)	Power supply is not supplied (close)
ABS IN valve	Power supply is not supplied (open)	Power supply is not supplied (open)
ABS OUT valve	Power supply is not supplied (close)	Power supply is not supplied (close)
Each brake caliper (fluid pressure)	—	Pressure decreases

Front RH brake caliper

- Since the suction valve 1 and the ABS OUT valve are closed and the cut valve 1 and the ABS IN valve are open, the fluid pressure applied on the front RH brake caliper is reduced by supplying the fluid pressure to the master cylinder via the ABS IN valve and the cut valve 1. The pressurization for the right caliper is controlled separately from the left caliper.

Front LH brake caliper

- Since the suction valve 2 and the ABS OUT valve are closed and the cut valve 2 and the ABS IN valve are open, the fluid pressure applied on the front LH brake caliper is reduced by supplying the fluid pressure to the master cylinder via the ABS IN valve and the cut valve 2. The pressurization for the left caliper is controlled separately from the right caliper.

Rear RH brake caliper

- Since the suction valve 2 and the ABS OUT valve are closed and the cut valve 2 and the ABS IN valve are open, the fluid pressure applied on the rear RH brake caliper is reduced by supplying the fluid pressure to the master cylinder via the ABS IN valve and the cut valve 2. The pressurization for the right caliper is controlled separately from the left caliper.

SYSTEM

< SYSTEM DESCRIPTION >

[WITHOUT ICC]

Rear LH brake caliper

- Since the suction valve 1 and the ABS OUT valve are closed and the cut valve 1 and the ABS IN valve are open, the fluid pressure applied on the rear LH brake caliper is reduced by supplying the fluid pressure to the master cylinder via the ABS IN valve and the cut valve 1. The pressurization for the left caliper is controlled separately from the right caliper.

Component Parts and Function

Component	Function
Pump	Returns the brake fluid reserved in reservoir to master cylinder by reducing pressure.
Motor	Activates the pump according to signals from ABS actuator and electric unit (control unit).
Cut valve 1 Cut valve 2	Shuts off the ordinary brake line from master cylinder.
Suction valve 1 Suction valve 2	Supplies the brake fluid from master cylinder to the pump.
ABS IN valve	Switches the fluid pressure line to increase or hold according to signals from control unit.
ABS OUT valve	Switches the fluid pressure line to increase, hold or decrease according to signals from control unit.
Return check valve	Returns the brake fluid from brake caliper to master cylinder by bypassing orifice of each valve when brake is released.
Reservoir	Temporarily reserves the brake fluid drained from brake caliper, so that pressure efficiently decreases when decreasing pressure of brake caliper.
Pressure sensor	Detects the brake fluid pressure and transmits signal to ABS actuator and electric unit (control unit).

VALVE OPERATION (ABS AND EBD FUNCTIONS)

The control unit built into the ABS actuator and electric unit (control unit) controls fluid pressure of the brake calipers by operating each valve.

Brake Pedal Applied or ABS Function Operating (Pressure Increases)

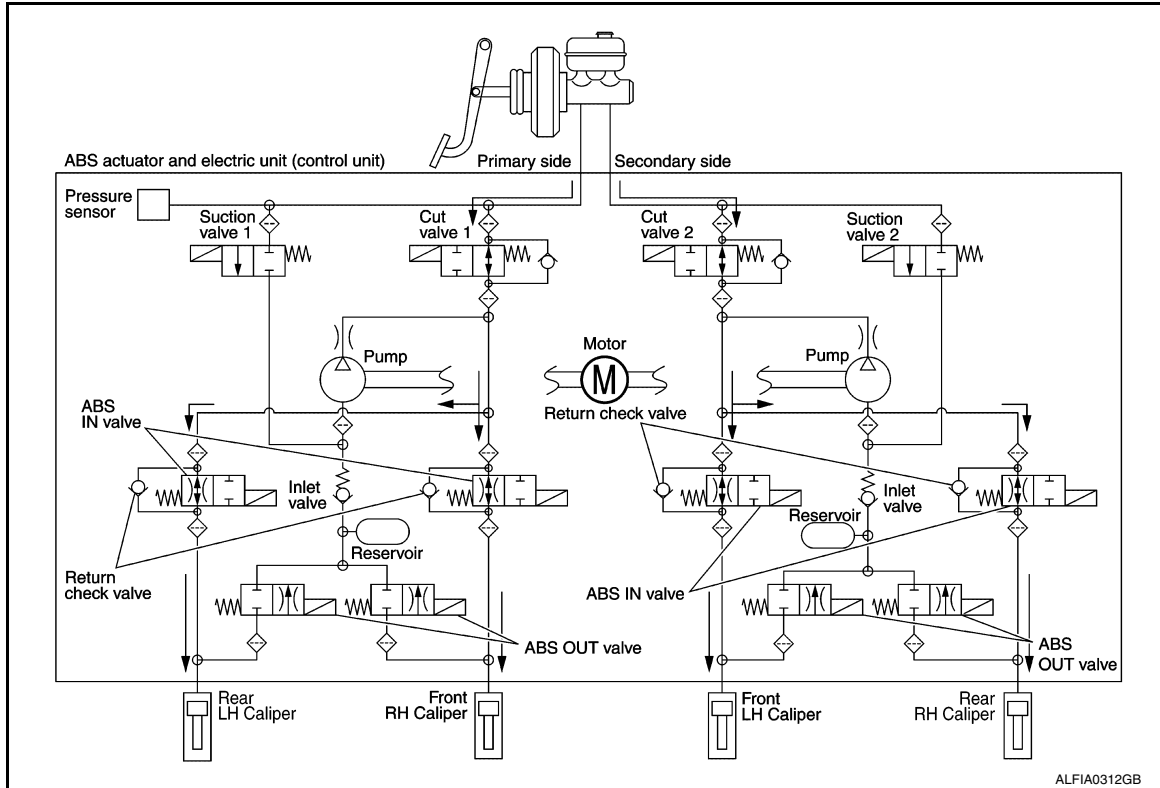

Name	Not activated	During pressure increases
Cut valve 1	Power supply is not supplied (open)	Power supply is not supplied (open)
Cut valve 2	Power supply is not supplied (open)	Power supply is not supplied (open)
Suction valve 1	Power supply is not supplied (close)	Power supply is not supplied (close)

SYSTEM

< SYSTEM DESCRIPTION >

[WITHOUT ICC]

Name	Not activated	During pressure increases
Suction valve 2	Power supply is not supplied (close)	Power supply is not supplied (close)
ABS IN valve	Power supply is not supplied (open)	Power supply is not supplied (open)
ABS OUT valve	Power supply is not supplied (close)	Power supply is not supplied (close)
Each brake caliper (fluid pressure)	—	Pressure increases

Front RH brake caliper

- When the cut valve 1 and the ABS IN valve opens, brake fluid is supplied to the front RH brake caliper from the master cylinder through the ABS IN valve. Brake fluid does not flow into the reservoir because the ABS OUT valve is closed.

Front LH brake caliper

- When the cut valve 2 and the ABS IN valve opens, brake fluid is supplied to the front LH brake caliper from the master cylinder through the ABS IN valve. Brake fluid does not flow into the reservoir because the ABS OUT valve is closed.

Rear RH brake caliper

- When the cut valve 2 and the ABS IN valve opens, brake fluid is supplied to the rear RH brake caliper from the master cylinder through the ABS IN valve. Brake fluid does not flow into the reservoir because the ABS OUT valve is closed.

Rear LH brake caliper

- When the cut valve 1 and the ABS IN valve opens, brake fluid is supplied to the rear LH brake caliper from the master cylinder through the ABS IN valve. Brake fluid does not flow into the reservoir because the ABS OUT valve is closed.

ABS Function Starts Operating (Pressure Holds)

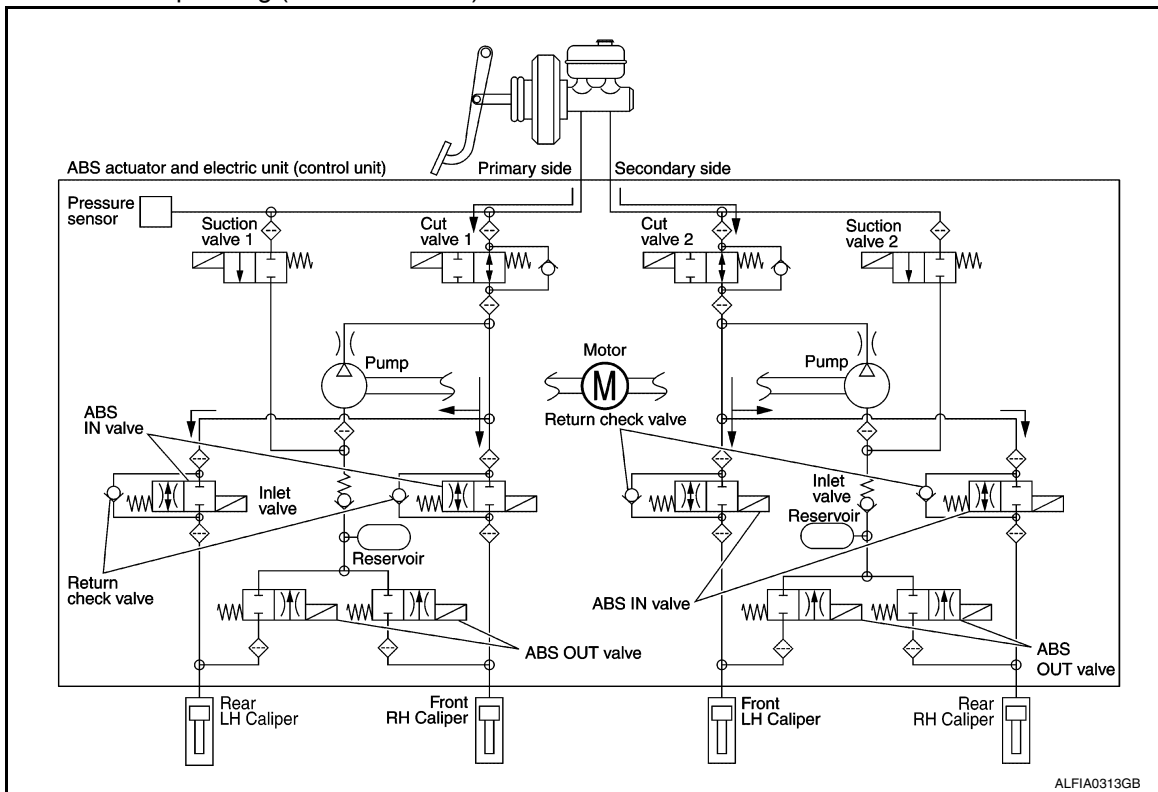

Name	Not activated	During pressure holds
Cut valve 1	Power supply is not supplied (open)	Power supply is not supplied (open)
Cut valve 2	Power supply is not supplied (open)	Power supply is not supplied (open)
Suction valve 1	Power supply is not supplied (close)	Power supply is not supplied (close)
Suction valve 2	Power supply is not supplied (close)	Power supply is not supplied (close)

SYSTEM

< SYSTEM DESCRIPTION >

[WITHOUT ICC]

Name	Not activated	During pressure holds
ABS IN valve	Power supply is not supplied (open)	Power supply is supplied (close)
ABS OUT valve	Power supply is not supplied (close)	Power supply is not supplied (close)
Each brake caliper (fluid pressure)	—	Pressure holds

Front RH brake caliper

- Since the ABS IN valve and the ABS OUT valve are closed, the front RH brake caliper, master cylinder, and reservoir are blocked. This maintains fluid pressure applied on the front RH brake caliper.

Front LH brake caliper

- Since the ABS IN valve and the ABS OUT valve are closed, the front LH brake caliper, master cylinder, and reservoir are blocked. This maintains fluid pressure applied on the front LH brake caliper.

Rear RH brake caliper

- Since the ABS IN valve and the ABS OUT valve are closed, the rear RH brake caliper, master cylinder, and reservoir are blocked. This maintains fluid pressure applied on the rear RH brake caliper.

Rear LH brake caliper

- Since the ABS IN valve and the ABS OUT valve are closed, the rear LH brake caliper, master cylinder, and reservoir are blocked. This maintains fluid pressure applied on the rear LH brake caliper.

ABS Function Operating (Pressure Decreases)

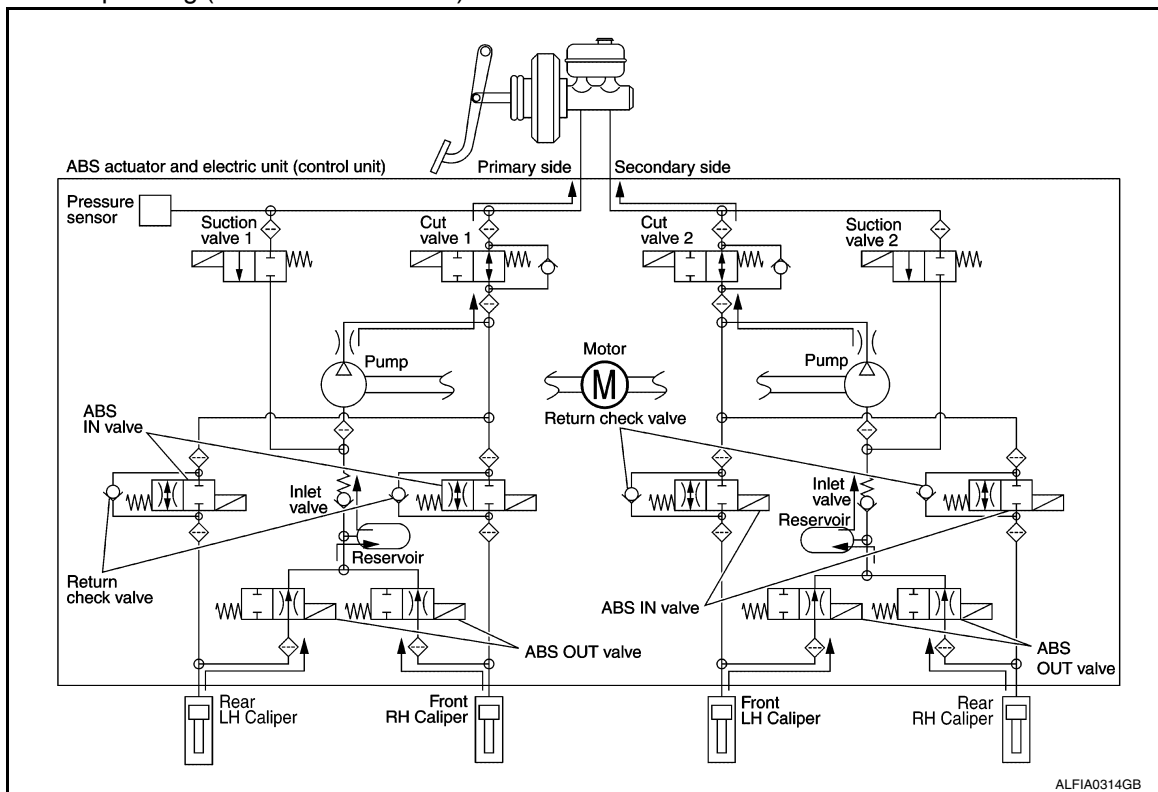

Name	Not activated	During pressure decreases
Cut valve 1	Power supply is not supplied (open)	Power supply is not supplied (open)
Cut valve 2	Power supply is not supplied (open)	Power supply is not supplied (open)
Suction valve 1	Power supply is not supplied (close)	Power supply is not supplied (close)
Suction valve 2	Power supply is not supplied (close)	Power supply is not supplied (close)
ABS IN valve	Power supply is not supplied (open)	Power supply is supplied (close)
ABS OUT valve	Power supply is not supplied (close)	Power supply is supplied (open)
Each brake caliper (fluid pressure)	—	Pressure decreases

SYSTEM

< SYSTEM DESCRIPTION >

[WITHOUT ICC]

Front RH brake caliper

- Since the ABS IN valve is closed and the ABS OUT valve is opened, fluid pressure applied on the front RH brake caliper is supplied to the reservoir through the ABS OUT valve. This fluid pressure decreases when sent to the master cylinder by the pump.

Front LH brake caliper

- Since the ABS IN valve is closed and the ABS OUT valve is opened, fluid pressure applied on the front LH brake caliper is supplied to the reservoir through the ABS OUT valve. This fluid pressure decreases when sent to the master cylinder by the pump.

Rear RH brake caliper

- Since the ABS IN valve is closed and the ABS OUT valve is opened, fluid pressure applied on the rear RH brake caliper is supplied to the reservoir through the ABS OUT valve. This fluid pressure decreases when sent to the master cylinder by the pump.

Rear LH brake caliper

- Since the ABS IN valve is closed and the ABS OUT valve is opened, fluid pressure applied on the rear LH brake caliper is supplied to the reservoir through the ABS OUT valve. This fluid pressure decreases when sent to the master cylinder by the pump.

ABS Function Operating (Pressure Increases)

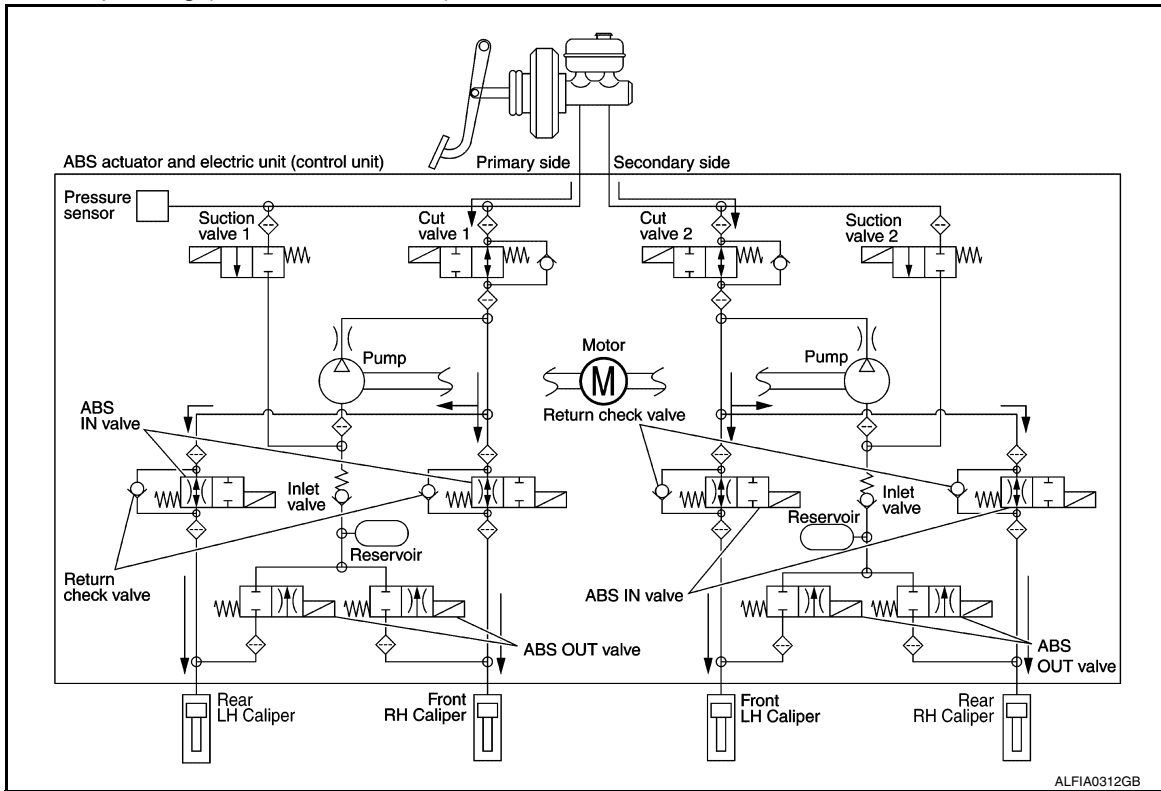

Name	Not activated	During pressure increases
Cut valve 1	Power supply is not supplied (open)	Power supply is not supplied (open)
Cut valve 2	Power supply is not supplied (open)	Power supply is not supplied (open)
Suction valve 1	Power supply is not supplied (close)	Power supply is not supplied (close)
Suction valve 2	Power supply is not supplied (close)	Power supply is not supplied (close)
ABS IN valve	Power supply is not supplied (open)	Power supply is not supplied (open)
ABS OUT valve	Power supply is not supplied (close)	Power supply is not supplied (close)
Each brake caliper (fluid pressure)	—	Pressure increases

Front RH brake caliper

- Brake fluid is supplied to the front RH brake caliper from the master cylinder through the cut valve 1 and the ABS IN valve. Since the suction valve 1 and the ABS OUT valve is closed, the fluid does not flow into the

SYSTEM

< SYSTEM DESCRIPTION >

[WITHOUT ICC]

reservoir. The amount of brake fluid supplied to the front RH brake caliper from the master cylinder is controlled according to time that the ABS IN valve is not energized (time that the ABS IN valve is open).

Front LH brake caliper

- Brake fluid is supplied to the front LH brake caliper from the master cylinder through the cut valve 2 and the ABS IN valve. Since the suction valve 2 and the ABS OUT valve is closed, the fluid does not flow into the reservoir. The amount of brake fluid supplied to the front LH brake caliper from the master cylinder is controlled according to time that the ABS IN valve is not energized (time that the ABS IN valve is open).

Rear RH brake caliper

- Brake fluid is supplied to the rear RH brake caliper from the master cylinder through the cut valve 2 and the ABS IN valve. Since the suction valve 2 and the ABS OUT valve is closed, the fluid does not flow into the reservoir. The amount of brake fluid supplied to the rear RH brake caliper from the master cylinder is controlled according to time that the ABS IN valve is not energized (time that the ABS IN valve is open).

Rear LH brake caliper

- Brake fluid is supplied to the rear LH brake caliper from the master cylinder through the cut valve 1 and the ABS IN valve. Since the suction valve 1 and the ABS OUT valve is closed, the fluid does not flow into the reservoir. The amount of brake fluid supplied to the rear LH brake caliper from the master cylinder is controlled according to time that the ABS IN valve is not energized (time that the ABS IN valve is open).

Brake Release

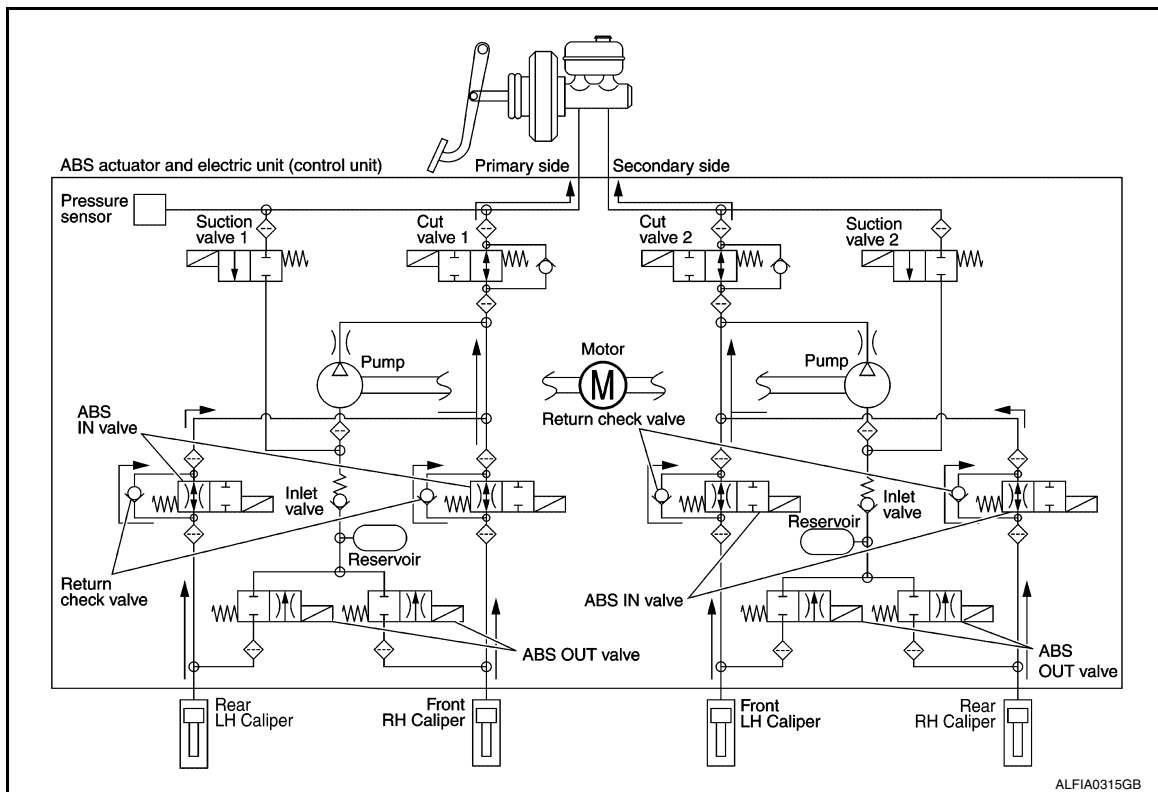

Name	Not activated	During brake release
Cut valve 1	Power supply is not supplied (open)	Power supply is not supplied (open)
Cut valve 2	Power supply is not supplied (open)	Power supply is not supplied (open)
Suction valve 1	Power supply is not supplied (close)	Power supply is not supplied (close)
Suction valve 2	Power supply is not supplied (close)	Power supply is not supplied (close)
ABS IN valve	Power supply is not supplied (open)	Power supply is not supplied (open)
ABS OUT valve	Power supply is not supplied (close)	Power supply is not supplied (close)
Each brake caliper (fluid pressure)	—	Pressure decreases

Front RH brake caliper

SYSTEM

< SYSTEM DESCRIPTION >

[WITHOUT ICC]

- Brake fluid is supplied to the front RH brake caliper through the return check valve of the ABS IN valve and the cut valve 1, and returns to the master cylinder.

Front LH brake caliper

- Brake fluid is supplied to the front LH brake caliper through the return check valve of the ABS IN valve and the cut valve 2, and returns to the master cylinder.

Rear RH brake caliper

- Brake fluid is supplied to the rear RH brake caliper through the return check valve of the ABS IN valve and the cut valve 2, and returns to the master cylinder.

Rear LH brake caliper

- Brake fluid is supplied to the rear LH brake caliper through the return check valve of the ABS IN valve and the cut valve 1, and returns to the master cylinder.

Component Parts and Function

Component	Function
Pump	Returns the brake fluid reserved in reservoir to master cylinder by reducing pressure.
Motor	Activates the pump according to signals from ABS actuator and electric unit (control unit).
Cut valve 1 Cut valve 2	Shuts off the ordinary brake line from master cylinder.
Suction valve 1 Suction valve 2	Supplies the brake fluid from master cylinder to the pump.
ABS IN valve	Switches the fluid pressure line to increase or hold according to signals from control unit.
ABS OUT valve	Switches the fluid pressure line to increase, hold or decrease according to signals from control unit.
Return check valve	Returns the brake fluid from brake caliper to master cylinder by bypassing orifice of each valve when brake is released.
Reservoir	Temporarily reserves the brake fluid drained from brake caliper, so that pressure efficiently decreases when decreasing pressure of brake caliper.
Pressure sensor	Detects the brake fluid pressure and transmits signal to ABS actuator and electric unit (control unit).

CONDITIONS FOR INDICATOR LAMP ILLUMINATION

- Turns ON when VDC and TCS functions are switched to non-operational status (OFF) by VDC OFF switch.
- Turns ON when ignition switch turns ON and turns OFF when the system is normal, for bulb check purposes.

Condition (status)	VDC OFF indicator lamp	Slip indicator lamp
Ignition switch OFF	OFF	OFF
For approx. 1 second after the ignition switch is turned ON	ON	ON
Approx. 2 seconds after ignition switch is turned ON (when the system is in normal operation)	OFF	OFF
When VDC OFF switch is ON (VDC function and TCS function are OFF)	ON	OFF
VDC function is malfunctioning	OFF	ON
TCS function is malfunctioning	OFF	ON

CONDITIONS FOR WARNING LAMP ILLUMINATION

Turns ON when ignition switch turns ON and turns OFF when the system is normal, for bulb check purposes.

Condition (status)	ABS warning lamp	Brake warning lamp
Ignition switch OFF	OFF	OFF
For approx. 1 second after the ignition switch is turned ON	ON	ON

SYSTEM

< SYSTEM DESCRIPTION >

[WITHOUT ICC]

Condition (status)	ABS warning lamp	Brake warning lamp
Approx. 2 second after ignition switch is turned ON (when the system is in normal operation)	OFF	OFF
After engine starts	OFF	OFF
When parking brake operates (parking brake switch ON)	OFF	ON
When brake fluid is less than the specified level (brake fluid level switch ON)	OFF	ON
When vacuum sensor is malfunctioning	OFF	ON
VDC function is malfunctioning	OFF	OFF
TCS function is malfunctioning	OFF	OFF
ABS function is malfunctioning	ON	OFF
EBD function is malfunctioning	ON	ON
VDC function is operating	OFF	OFF
TCS function is operating	OFF	OFF
Hill start assist function	OFF	OFF
Brake assist	OFF	OFF

Fail-Safe

INFOID:000000012894392

VDC FUNCTION, TCS FUNCTION, BRAKE ASSIST FUNCTION AND HILL START ASSIST FUNCTION

VDC warning lamp in combination meter turns ON when a malfunction occurs in system [ABS actuator and electric unit (control unit)]. The control is suspended for VDC function, TCS function, brake assist function and hill start assist function. The vehicle status becomes the same as models without VDC function, TCS function, brake assist function and hill start assist function. However, ABS function and EBD function operate normally.

ABS FUNCTION

ABS warning lamp and VDC warning lamp in combination meter turn ON when a malfunction occurs in system [ABS actuator and electric unit (control unit)]. The control is suspended for VDC function, TCS function, ABS function, brake assist function and hill start assist function. The vehicle status becomes the same as models without VDC function, TCS function, ABS function, brake assist function and hill start assist function. However, EBD function operates normally.

NOTE:

ABS self-diagnosis sound may be heard the same as in the normal condition, because self-diagnosis is performed when ignition switch turns ON and when vehicle initially starts.

EBD FUNCTION

ABS warning lamp, brake warning lamp and VDC warning lamp in combination meter turn ON when a malfunction occurs in system [ABS actuator and electric unit (control unit)]. The control is suspended for VDC function, TCS function, ABS function, EBD function, brake assist function and hill start assist function. The vehicle status becomes the same as models without VDC function, TCS function, ABS function, EBD function, brake assist function and hill start assist function.

DTC	Fail-safe condition
C1101	The following functions are suspended: <ul style="list-style-type: none"> • VDC function • TCS function • ABS function • EBD function (only when both rear wheels are malfunctioning) • Brake assist function • Hill start assist function
C1102	
C1103	
C1104	
C1105	
C1106	
C1107	
C1108	

SYSTEM

< SYSTEM DESCRIPTION >

[WITHOUT ICC]

DTC	Fail-safe condition
C1109	The following functions are suspended:
C1110	<ul style="list-style-type: none"> • VDC function • TCS function • ABS function • EBD function • Brake assist function • Hill start assist function
C1111	The following functions are suspended: <ul style="list-style-type: none"> • VDC function • TCS function • ABS function • Brake assist function • Hill start assist function
C1113	The following functions are suspended: <ul style="list-style-type: none"> • VDC function • TCS function • ABS function¹ • Brake assist function¹ • Hill start assist function
C1115	The following functions are suspended: <ul style="list-style-type: none"> • VDC function • TCS function • ABS function • EBD function • Brake assist function • Hill start assist function
C1116	The following functions are suspended: <ul style="list-style-type: none"> • VDC function • TCS function • Brake assist function • Hill start assist function
C1120	The following functions are suspended: <ul style="list-style-type: none"> • VDC function • TCS function • ABS function • EBD function • Brake assist function • Hill start assist function
C1121	
C1122	
C1123	
C1124	
C1125	
C1126	
C1127	
C1130	The following functions are suspended: <ul style="list-style-type: none"> • VDC function • TCS function • Hill start assist function
C1140	The following functions are suspended: <ul style="list-style-type: none"> • VDC function • TCS function • ABS function • EBD function • Brake assist function • Hill start assist function
C1142	The following functions are suspended: <ul style="list-style-type: none"> • VDC function • TCS function • Brake assist function • Hill start assist function

SYSTEM

< SYSTEM DESCRIPTION >

[WITHOUT ICC]

DTC	Fail-safe condition	A
C1143	The following functions are suspended:	B
C1144	<ul style="list-style-type: none"> • VDC function • TCS function • Hill start assist function 	
C1145	The following functions are suspended:	C
C1146	<ul style="list-style-type: none"> • VDC function • TCS function • ABS function¹ • Brake assist function¹ • Hill start assist function 	
C1153	The following functions are suspended:	D
	<ul style="list-style-type: none"> • VDC function • TCS function • ABS function • Brake assist function • Hill start assist function 	E
C1154	The following functions are suspended:	BRC
	<ul style="list-style-type: none"> • VDC function • TCS function • Hill start assist function 	G
C1155	The following functions are suspended:	H
	<ul style="list-style-type: none"> • VDC function • TCS function • Brake assist function • Hill start assist function 	I
C1160	The following functions are suspended:	J
	<ul style="list-style-type: none"> • VDC function • TCS function • ABS function¹ • Brake assist function¹ • Hill start assist function 	K
C1164	The following functions are suspended:	L
C1165	• VDC function	
C1166	• TCS function	
C1167	• ABS function	
C1170	• EBD function	
C1197	• Brake assist function	M
C1198	• Hill start assist function	
C1199	Electrical vacuum assistance of brake booster is suspended.	N
C119A	Normal control	O
C119A	Electrical vacuum assistance of brake booster is suspended.	P
U1000	The following functions are suspended:	P
U1002	<ul style="list-style-type: none"> • VDC function • TCS function • Brake assist function • Hill start assist function 	

¹: AWD models

VDC FUNCTION

VDC FUNCTION : System Description

INFOID:000000012894393

SYSTEM DIAGRAM

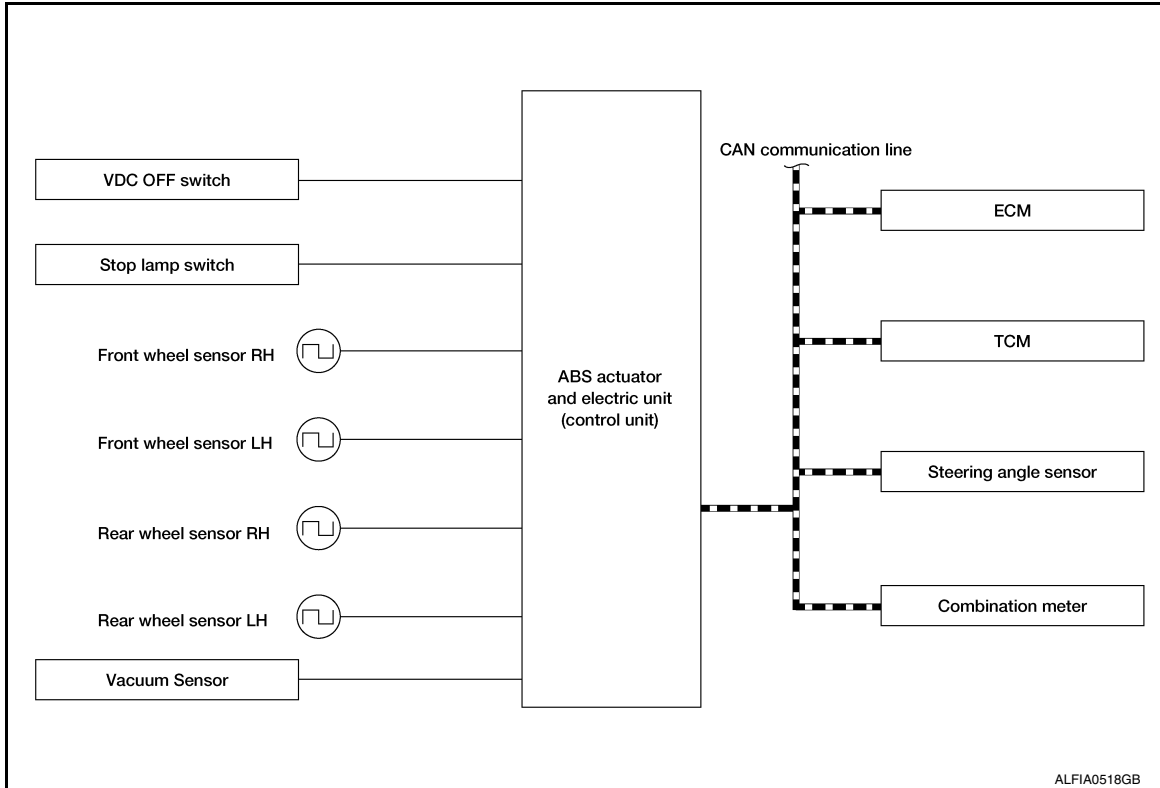

- Side slip or tail slip may occur while driving on a slippery road or intending urgent evasive driving. VDC function detects side slip status using each sensor when side slip or tail slip is about to occur and improves vehicle stability by brake control and engine output control during driving.
- In addition to ABS function, EBD function and TCS function, target side slip amount is calculated according to steering operation amount from steering angle sensor and brake operation amount from brake pressure sensor. By comparing this information with vehicle side slip amount that is calculated from information from yaw rate/side/decel G sensor and wheel sensor, vehicle driving conditions (conditions of understeer or oversteer) are judged and vehicle stability is improved by brake force control on all wheels and engine output control.

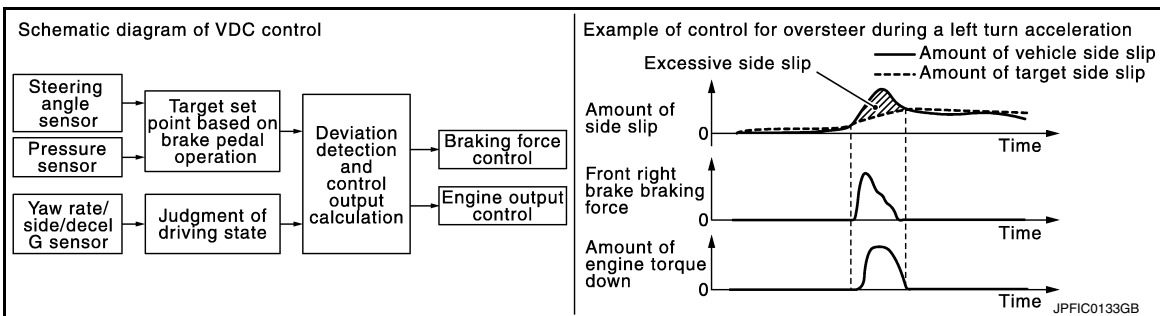

- VDC function can be switched to non-operational status (OFF) by operating VDC OFF switch. In this case, VDC OFF indicator lamp turns ON.
- Control unit portion automatically improves driving stability by performing brake force control as well as engine output control, by transmitting drive signal to actuator portion according to difference between target side slip amount and vehicle side slip amount
- VDC warning lamp blinks while VDC function is in operation and indicates to the driver that the function is in operation.
- CONSULT can be used to diagnose the system diagnosis.
- Fail-safe function is adopted. When a malfunction occurs in VDC function, the control is suspended for VDC function, TCS function, brake assist function, hill start assist function and brake force distribution function. The vehicle status becomes the same as models without VDC function, TCS function, brake assist function and hill start assist function. However, ABS function and EBD function are operated normally. Refer to [BRC-47. "Fail-Safe"](#).

SYSTEM

< SYSTEM DESCRIPTION >

[WITHOUT ICC]

INPUT SIGNAL AND OUTPUT SIGNAL

Major signal transmission between each unit via communication lines is shown in the following table:

Component	Signal description
ECM	<p>Mainly transmits the following signals to ABS actuator and electric unit (control unit) via CAN communication:</p> <ul style="list-style-type: none"> • Accelerator pedal position signal • Engine speed signal • Engine torque signal <p>Mainly receives the following signal from ABS actuator and electric unit (control unit) via CAN communication:</p> <ul style="list-style-type: none"> • Engine torque request signal
TCM	<p>Mainly transmits the following signal to ABS actuator and electric unit (control unit) via CAN communication:</p> <ul style="list-style-type: none"> • Current gear position signal
Combination meter	<p>Mainly receives the following signals from ABS actuator and electric unit (control unit) via CAN communication:</p> <ul style="list-style-type: none"> • Brake fluid level switch signal • Parking brake switch signal <p>Mainly receives the following signals from ABS actuator and electric unit (control unit) via CAN communication:</p> <ul style="list-style-type: none"> • VDC warning lamp signal • VDC OFF indicator lamp signal
Steering angle sensor	<p>Mainly transmits the following signals to ABS actuator and electric unit (control unit) via CAN communication:</p> <ul style="list-style-type: none"> • Steering angle sensor signal • Steering angle sensor malfunction signal

OPERATION CHARACTERISTICS

VDC Function That Prevents Oversteer Tendency

- During cornering, brake force (brake fluid pressure) is applied on front wheel and rear wheel on the outer side of turn. Momentum directing towards the outer side of turn is generated. Oversteer is prevented.

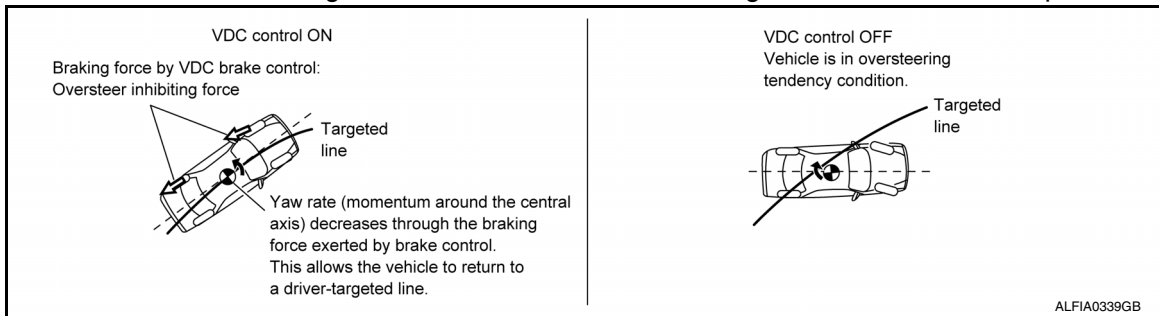

- Changing driving lane on a slippery road when oversteer tendency is judged large, engine output is controlled as well as brake force (brake fluid pressure) of 4 wheels. Oversteer tendency decreases.

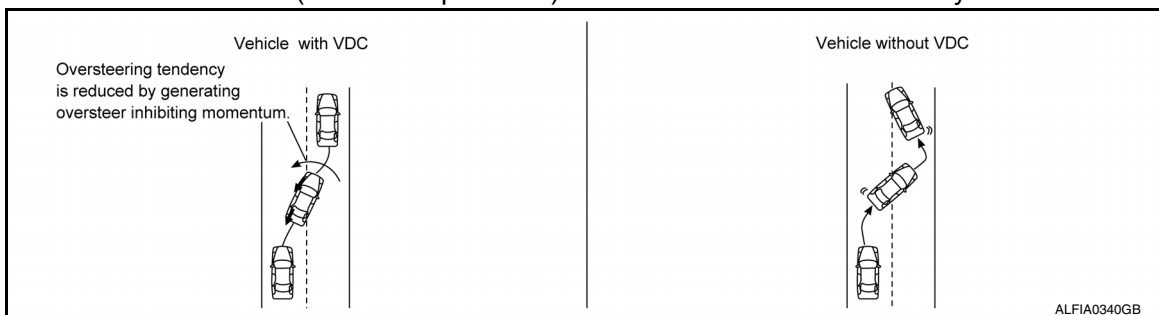

VDC Function That Prevents Understeer Tendency

SYSTEM

< SYSTEM DESCRIPTION >

[WITHOUT ICC]

- During cornering, brake force (brake fluid pressure) is applied on front wheel and rear wheel on the inner side of turn. Momentum directing towards the inner side of turn is generated. Understeer is prevented.

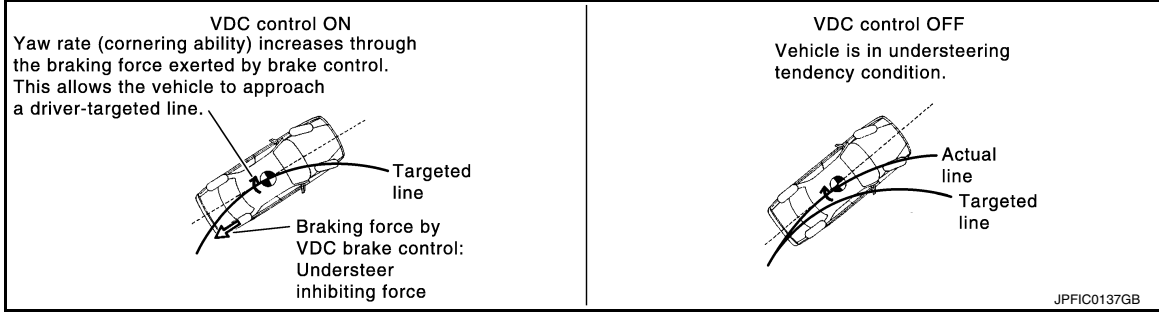

- Applying braking during cornering on a slippery road when understeer tendency is judged large, engine output is controlled as well as brake force (brake fluid pressure) of four wheels. Understeer tendency decreases.

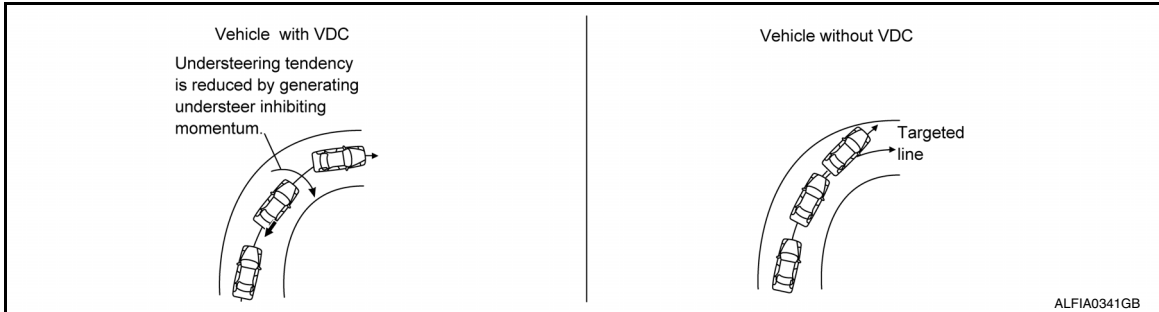

TCS FUNCTION

TCS FUNCTION : System Description

INFOID:000000012894394

SYSTEM DIAGRAM

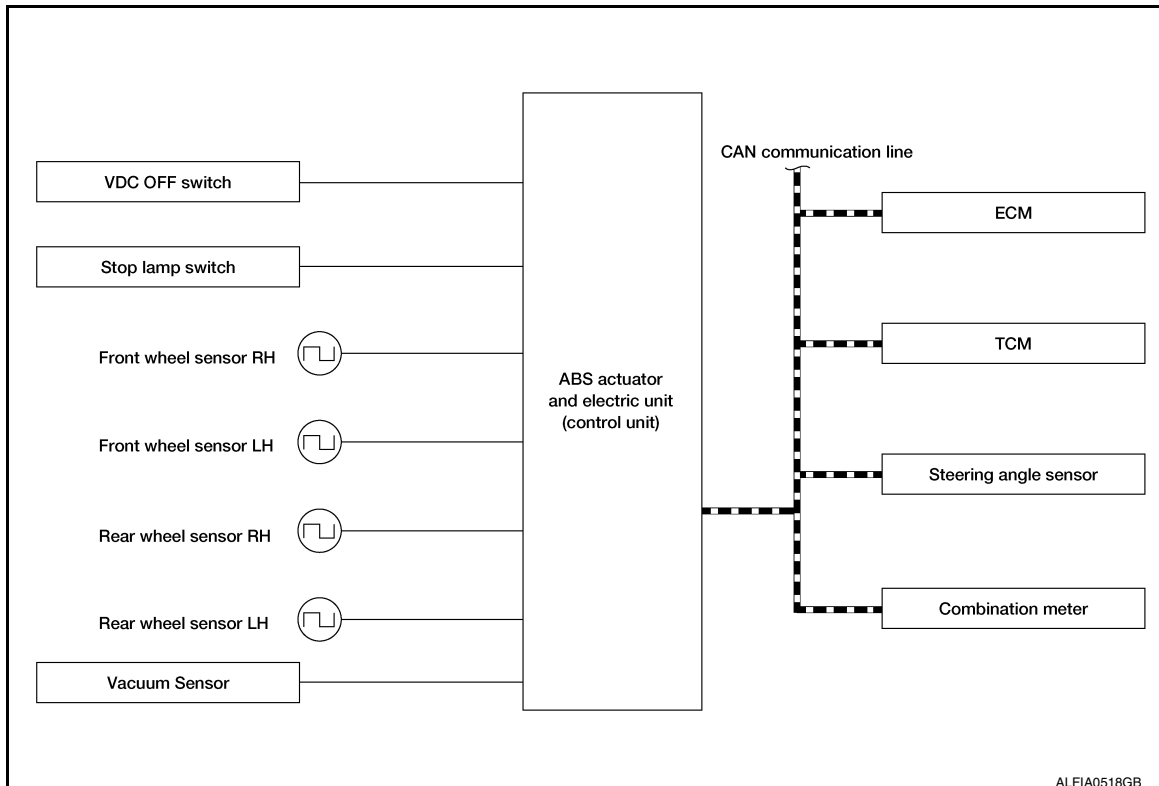

SYSTEM

< SYSTEM DESCRIPTION >

[WITHOUT ICC]

- Wheel spin status of drive wheel is detected by wheel sensor of 4 wheels. Engine output and transmission shift status are controlled so that slip rate of drive wheels is in appropriate level. When wheel spin occurs on drive wheel, ABS actuator and electric unit (control unit) performs brake force control of LH and RH drive wheels (applies brake force by increasing brake fluid pressure of drive wheel) and decreases engine torque by engine torque control. Wheel spin amount decreases. Engine torque is controlled to appropriate level.
- TCS function can be switched to non-operational status (OFF) by operating VDC OFF switch. In this case, VDC OFF indicator lamp turns ON.
- VDC warning lamp blinks while TCS function is in operation and indicates to the driver that the function is in operation.
- CONSULT can be used to diagnose the system diagnosis.
- Fail-safe function is adopted. When a malfunction occurs in TCS function, the control is suspended for VDC function, TCS function, brake assist function and hill start assist function. The vehicle status becomes the same as models without VDC function, TCS function, brake assist function and hill start assist function. However, ABS function and EBD function are operated normally. Refer to [BRC-47. "Fail-Safe"](#).

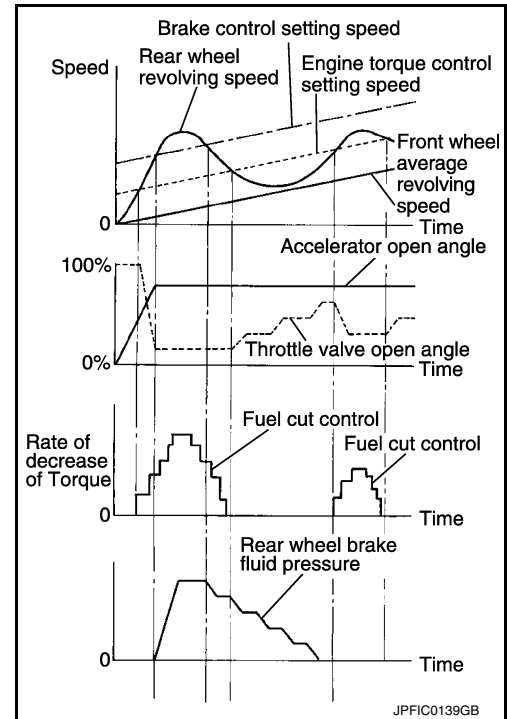

SYSTEM DIAGRAM

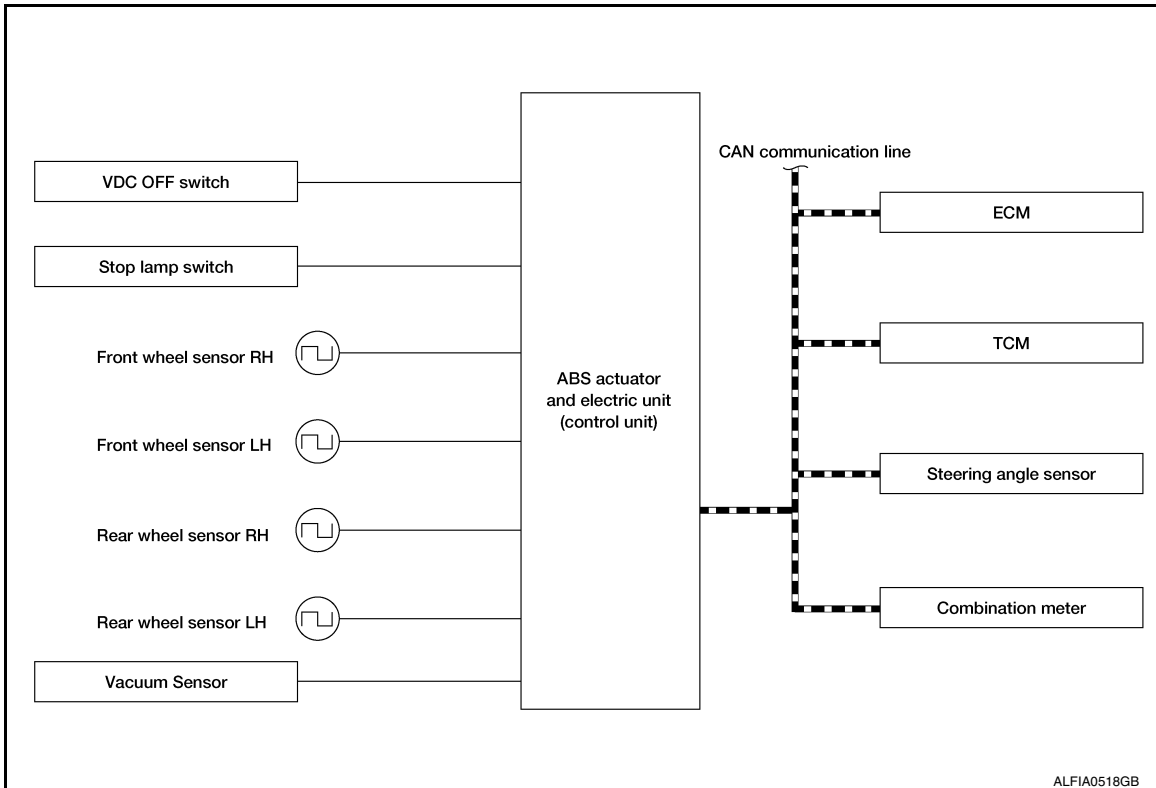

INPUT SIGNAL AND OUTPUT SIGNAL

Major signal transmission between each unit via communication lines is shown in the following table:

SYSTEM

< SYSTEM DESCRIPTION >

[WITHOUT ICC]

Component	Signal description
ECM	Mainly transmits the following signals to ABS actuator and electric unit (control unit) via CAN communication: <ul style="list-style-type: none"> • Accelerator pedal position signal • Engine speed signal • Engine torque signal Mainly receives the following signal from ABS actuator and electric unit (control unit) via CAN communication: <ul style="list-style-type: none"> • Engine torque request signal
TCM	Mainly transmits the following signal to ABS actuator and electric unit (control unit) via CAN communication: <ul style="list-style-type: none"> • Current gear position signal
Combination meter	Mainly receives the following signals from ABS actuator and electric unit (control unit) via CAN communication: <ul style="list-style-type: none"> • Brake fluid level switch signal • Parking brake switch signal Mainly receives the following signals from ABS actuator and electric unit (control unit) via CAN communication: <ul style="list-style-type: none"> • VDC warning lamp signal • VDC OFF indicator lamp signal
Steering angle sensor	Mainly transmits the following signals to ABS actuator and electric unit (control unit) via CAN communication: <ul style="list-style-type: none"> • Steering angle sensor signal • Steering angle sensor malfunction signal

ABS FUNCTION

ABS FUNCTION : System Description

INFOID:000000012894395

SYSTEM DIAGRAM

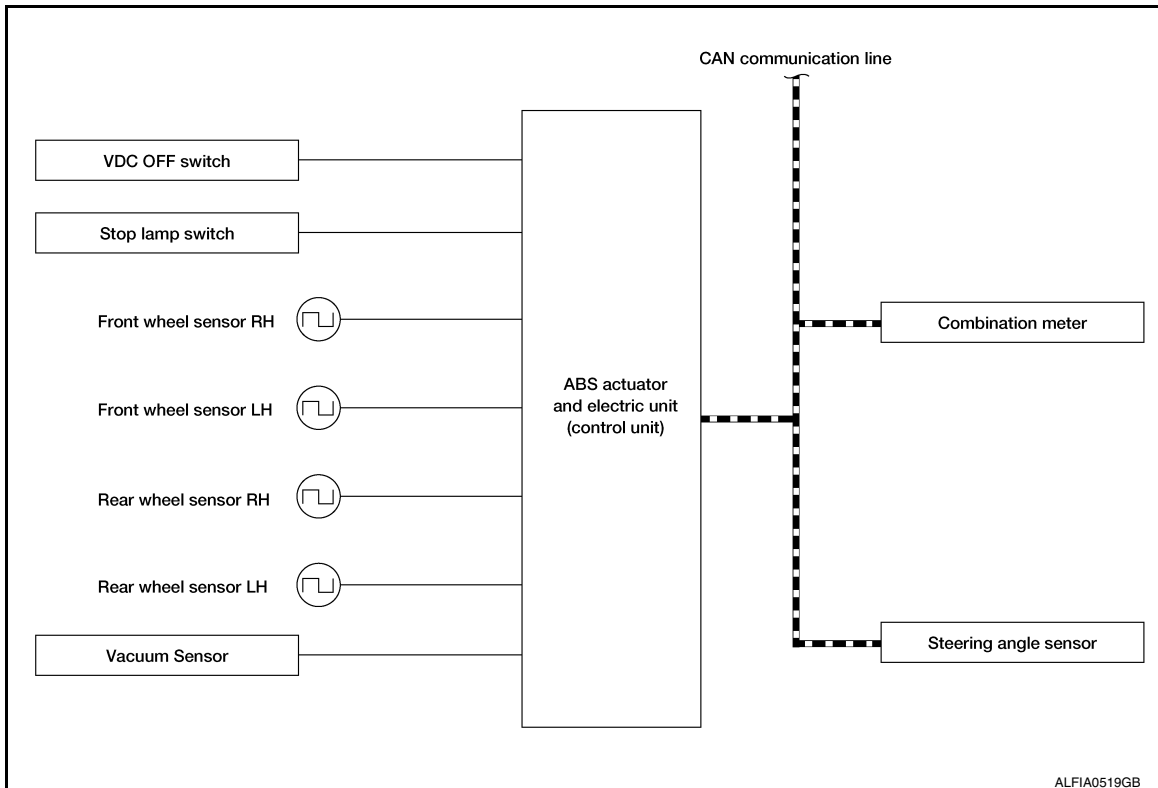

- By preventing wheel lock through brake force (brake fluid pressure) control that is electronically controlled by detecting wheel speed during braking, stability during emergency braking is improved so that obstacles can be easily bypassed by steering operation.
- During braking, control units calculate wheel speed and pseudo-vehicle speed and transmits pressure increase, hold or decrease signals to actuator portion according to wheel slip status.

SYSTEM

< SYSTEM DESCRIPTION >

[WITHOUT ICC]

- The following effects are obtained by preventing wheel lock during braking:
 - Vehicle tail slip is prevented during braking when driving straight.
 - Understeer and oversteer tendencies are moderated during braking driving on a corner.
 - Obstacles may be easily bypassed by steering operation during braking.
- CONSULT can be used to diagnose the system diagnosis.
- Fail-safe function is adopted. When a malfunction occurs in ABS function, the control is suspended for VDC function, TCS function, ABS function and hill start assist function. The vehicle status becomes the same as models without VDC function, TCS function, ABS function, brake assist function and hill start assist function. However, EBD function is operated normally. Refer to [BRC-47, "Fail-Safe"](#).

NOTE:

- ABS has the characteristics as described here. This is not a device that helps reckless driving.
- To stop vehicle efficiently, ABS does not operate and ordinary brake operates at low speed [approx. 10 km/h (6 MPH) or less, but differs subject to road conditions].
- Self-diagnosis is performed immediately after engine starts and when vehicle initially is driven [by vehicle speed approx. 15 km/h (9 MPH)]. Motor sounds are generated during self-diagnosis. In addition, brake pedal may be feel heavy when depressing brake pedal lightly. These symptoms are not malfunctions.

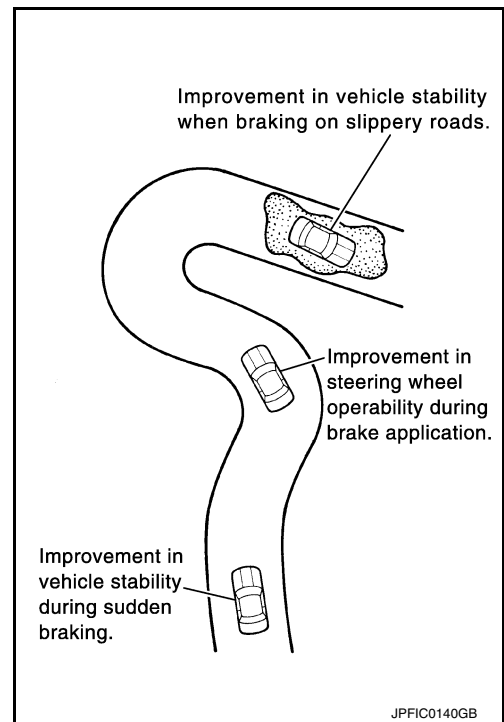

A
B
C
D
E

BRC

G
H

INPUT SIGNAL AND OUTPUT SIGNAL

Major signal transmission between each unit via communication lines is shown in the following table:

Component	Signal description
Combination meter	Mainly receives the following signals from ABS actuator and electric unit (control unit) via CAN communication: <ul style="list-style-type: none"> • Brake fluid level switch signal • Parking brake switch signal Mainly receives the following signals from ABS actuator and electric unit (control unit) via CAN communication: <ul style="list-style-type: none"> • ABS warning lamp signal • VDC warning lamp signal • VDC OFF indicator lamp signal
Steering angle sensor	Mainly transmits the following signals to ABS actuator and electric unit (control unit) via CAN communication: <ul style="list-style-type: none"> • Steering angle sensor signal • Steering angle sensor malfunction signal

I
J
K
L
M

EBD FUNCTION

N
O
P

EBD FUNCTION : System Description

INFOID:000000012894396

SYSTEM DIAGRAM

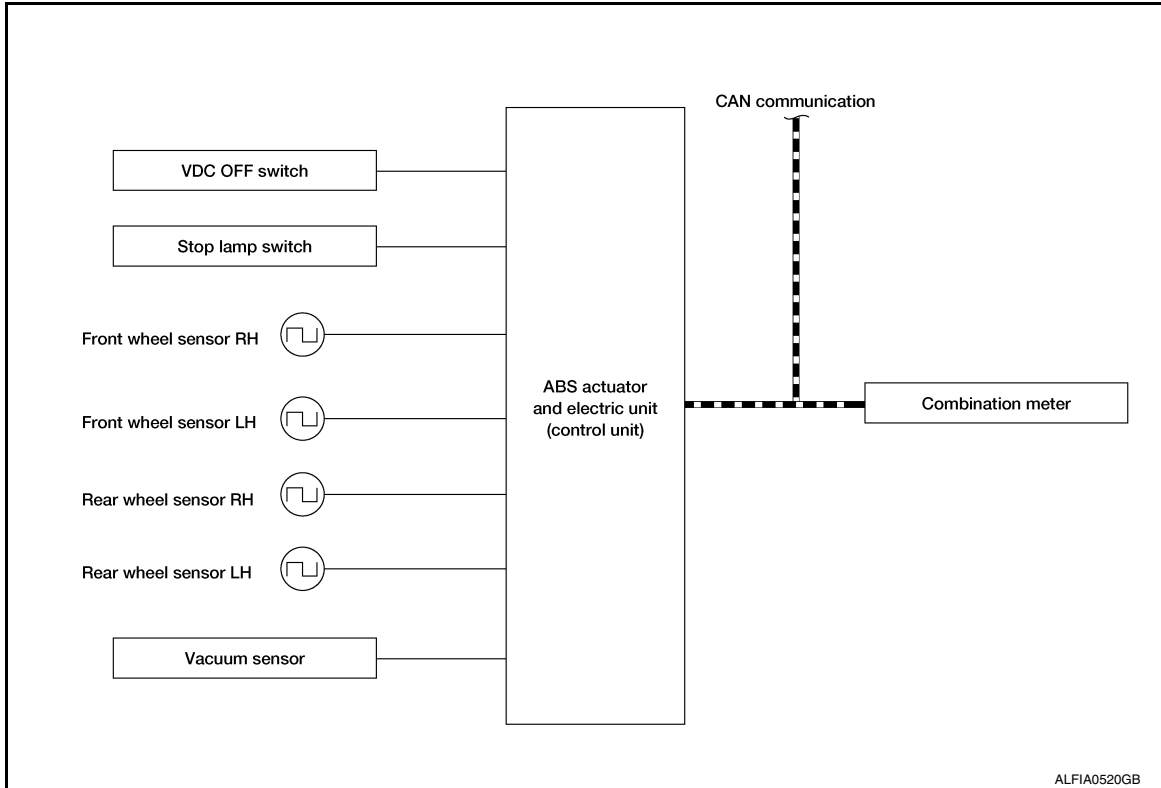

- By preventing rear wheel slip increase through rear wheel brake force (brake fluid pressure) control that is electronically controlled when slight slip on front and rear wheels is detected during braking, stability during braking is improved.
- EBD function is expanded and developed from conventional ABS function and corrects rear wheel brake force to appropriate level by electronic control according to load weight (number of passengers).

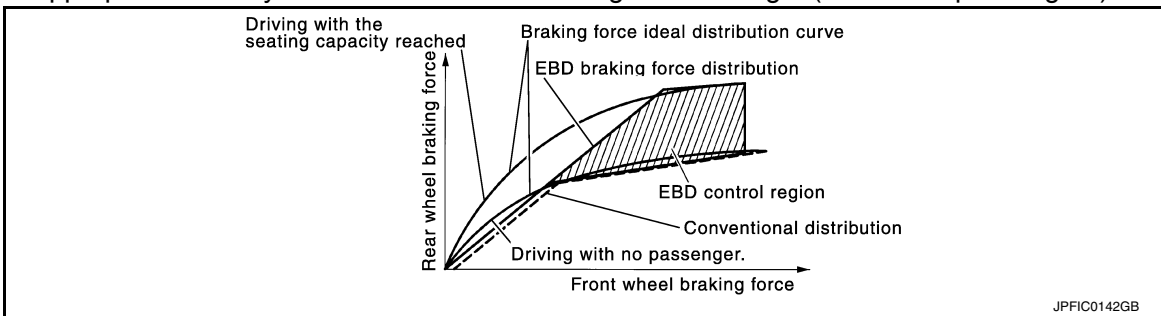

SYSTEM

< SYSTEM DESCRIPTION >

[WITHOUT ICC]

- During braking, control unit portion compares slight slip on front and rear wheels by wheel speed sensor signal, transmits drive signal to actuator portion when rear wheel slip exceeds front wheel slip for the specified value or more, and controls rear wheel brake force (brake fluid pressure) so that increase of rear wheel slip is prevented and slips on front wheel and rear wheel are nearly equalized. ABS control is applied when slip on each wheel increases and wheel speed is the threshold value of ABS control or less.
- CONSULT can be used to diagnose the system diagnosis.
- Fail-safe function is adopted. When a malfunction occurs in EBD function, the control is suspended for VDC function, TCS function, ABS function, EBD function, brake assist function and hill start assist function. The vehicle status becomes the same as models without VDC function, TCS function, ABS function, EBD function, brake assist function and hill start assist function. Refer to [BRC-47](#), "[Fail-Safe](#)".

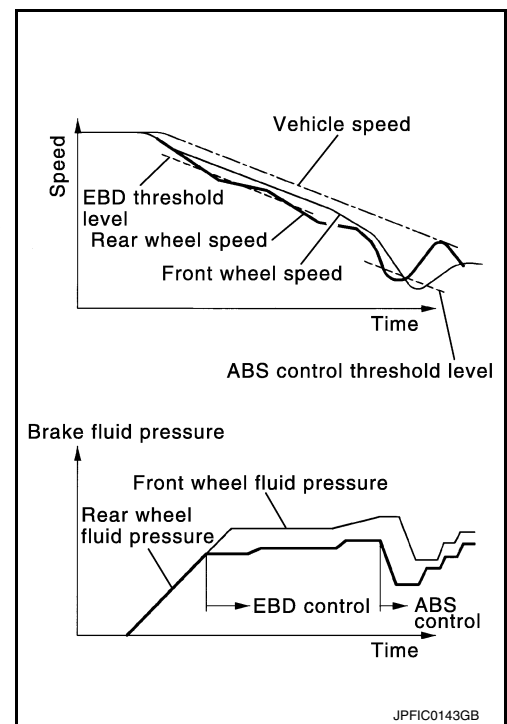

INPUT SIGNAL AND OUTPUT SIGNAL

Major signal transmission between each unit via communication lines is shown in the following table:

Component	Signal description
Combination meter	Mainly receives the following signals from ABS actuator and electric unit (control unit) via CAN communication: <ul style="list-style-type: none"> • VDC warning lamp signal • ABS warning lamp signal • Brake warning lamp signal

BRAKE ASSIST FUNCTION

BRAKE ASSIST FUNCTION : System Description

INFOID:000000012894397

SYSTEM DIAGRAM

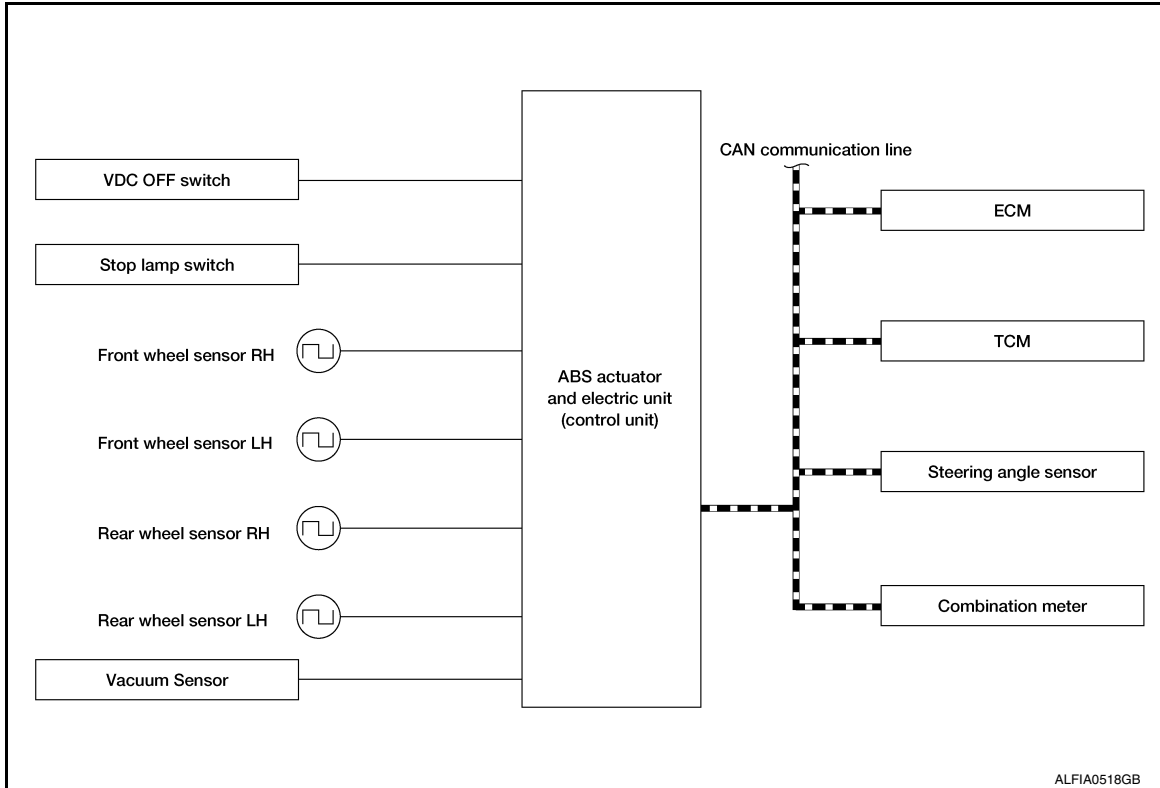

- When the driver brakes hard in an emergency, the stopping distance is reduced by increasing brake fluid pressure.
- Fail-safe function is adopted. When a malfunction occurs in brake assist function, the control is suspended for VDC function, TCS function, brake assist function and hill start assist function. The vehicle status becomes the same as models without VDC function, TCS function, brake assist function and hill start assist function. However, ABS function and EBD function are operated normally. Refer to [BRC-47, "Fail-Safe"](#).

INPUT SIGNAL AND OUTPUT SIGNAL

Major signal transmission between each unit via communication lines is shown in the following table:

Component	Signal description
ECM	<p>Mainly transmits the following signal to ABS actuator and electric unit (control unit) via CAN communication:</p> <ul style="list-style-type: none"> • Accelerator pedal position signal • Engine speed signal • Engine torque signal <p>Mainly receives the following signal from ABS actuator and electric unit (control unit) via CAN communication:</p> <ul style="list-style-type: none"> • Engine torque request signal
TCM	<p>Mainly transmits the following signal to ABS actuator and electric unit (control unit) via CAN communication:</p> <ul style="list-style-type: none"> • Current gear position signal

SYSTEM

< SYSTEM DESCRIPTION >

[WITHOUT ICC]

Component	Signal description
Combination meter	Mainly receives the following signals from ABS actuator and electric unit (control unit) via CAN communication: <ul style="list-style-type: none"> • Brake fluid level switch signal • Parking brake switch signal Mainly receives the following signals from ABS actuator and electric unit (control unit) via CAN communication: <ul style="list-style-type: none"> • VDC warning lamp signal • VDC OFF indicator lamp signal
Steering angle sensor	Mainly transmits the following signals to ABS actuator and electric unit (control unit) via CAN communication: <ul style="list-style-type: none"> • Steering angle sensor signal • Steering angle sensor malfunction signal

hill start assist FUNCTION

hill start assist FUNCTION : System Description

INFOID:0000000012894398

SYSTEM DIAGRAM

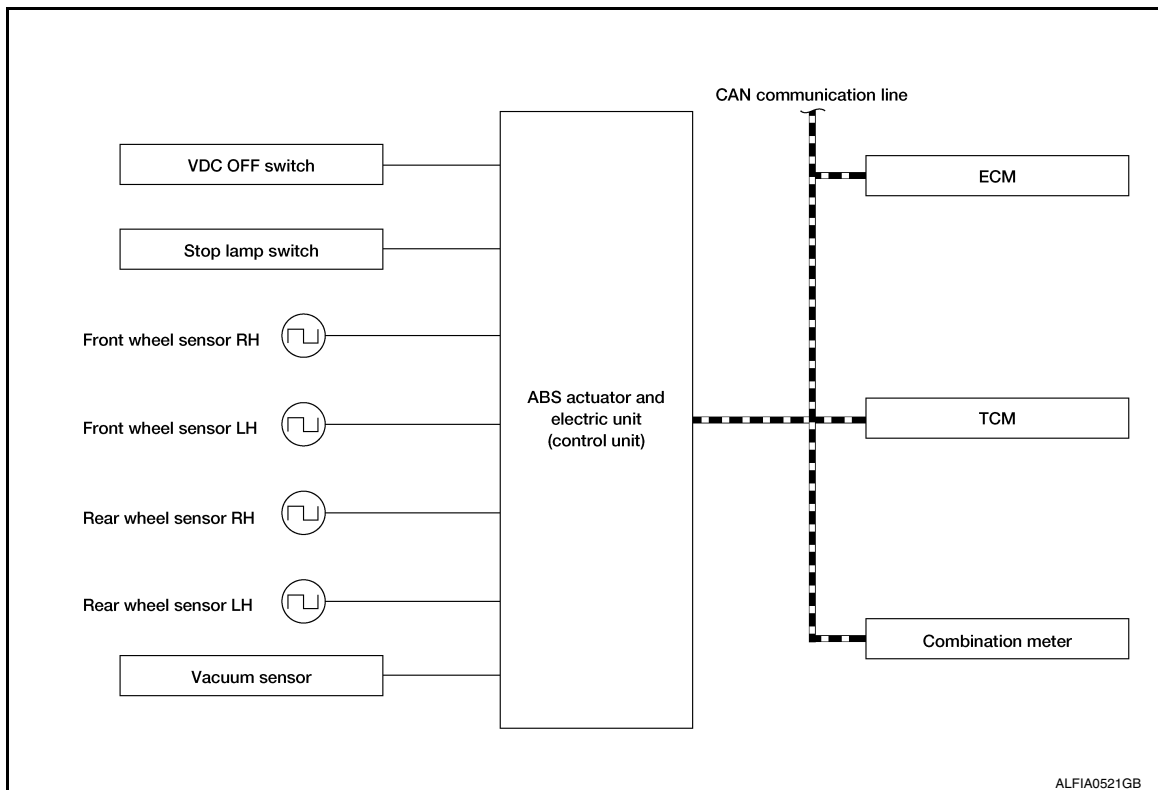

- This function maintains brake fluid pressure so that the vehicle does not move backward even if brake pedal is released to depress accelerator pedal to start the vehicle while it is stopped on an uphill slope by depressing brake pedal.
- This function operates when the vehicle is in stop status on a uphill slope of slope ratio 10% or more and selector lever is in a position other than P or N.
- Hill start assist function is only for the start aid. It maintains the brake fluid pressure for approximately 2 seconds after releasing the brake pedal and then decreases the pressure gradually. If the vehicle can start by the accelerator operation, the brake is released automatically and a smooth start can be performed.
- Fail-safe function is adopted. When a malfunction occurs in hill start assist function, the control is suspended for VDC function, TCS function, brake assist function and hill start assist function. The vehicle status becomes the same as models without VDC function, TCS function, brake assist function and hill start assist function. However, ABS function and EBD function are operated normally. Refer to [BRC-47. "Fail-Safe"](#).

INPUT SIGNAL AND OUTPUT SIGNAL

Major signal transmission between each unit via communication lines is shown in the following table:

SYSTEM

< SYSTEM DESCRIPTION >





[WITHOUT ICC]

Component	Signal description
ECM	<p>Mainly transmits the following signals to ABS actuator and electric unit (control unit) via CAN communication:</p> <ul style="list-style-type: none"> • Accelerator pedal position signal • Engine speed signal • Engine torque signal <p>Mainly receives the following signal from ABS actuator and electric unit (control unit) via CAN communication:</p> <ul style="list-style-type: none"> • Engine torque request signal
TCM	<p>Mainly transmits the following signal to ABS actuator and electric unit (control unit) via CAN communication:</p> <ul style="list-style-type: none"> • Current gear position signal
Combination meter	<p>Mainly receives the following signals from ABS actuator and electric unit (control unit) via CAN communication:</p> <ul style="list-style-type: none"> • Brake fluid level switch signal • Parking brake switch signal <p>Mainly receives the following signals from ABS actuator and electric unit (control unit) via CAN communication:</p> <ul style="list-style-type: none"> • VDC warning lamp signal • VDC OFF indicator lamp signal

WARNING/INDICATOR/CHIME LIST

WARNING/INDICATOR/CHIME LIST : Warning Lamp/Indicator Lamp

INFOID:000000012894399

Name	Design	Layout/Function
ABS warning lamp	<p>ABS</p> <p>or</p> 	<p>For function: Refer to BRC-154, "Component Function Check".</p>
Brake warning lamp	<p>BRAKE</p> <p>or</p> 	<p>For function: Refer to BRC-155, "Component Function Check".</p>
VDC OFF indicator lamp		<p>For function: Refer to BRC-158, "Component Function Check".</p>
VDC warning lamp		<p>For function: Refer to BRC-157, "Component Function Check".</p>

DIAGNOSIS SYSTEM [ABS ACTUATOR AND ELECTRIC UNIT (CONTROL UNIT)]

< SYSTEM DESCRIPTION >

[WITHOUT ICC]

DIAGNOSIS SYSTEM [ABS ACTUATOR AND ELECTRIC UNIT (CONTROL UNIT)]

CONSULT Function

INFOID:000000012894400

APPLICATION ITEMS

CONSULT can display each diagnostic item using the diagnostic test modes as follows:

Mode	Function description
ECU Identification	Part number of ABS actuator and electric unit (control unit) can be read.
Self Diagnostic Result	Self-diagnostic results and freeze frame data can be read and erased quickly.*
Data Monitor	Input/Output data in the ABS actuator and electric unit (control unit) can be read.
Active Test	Diagnostic Test Mode in which CONSULT drives some actuators apart from the ABS actuator and electric unit (control unit) and also shifts some parameters in a specified range.
Work support	Components can be quickly and accurately adjusted.
Re/programming, Configuration	<ul style="list-style-type: none">• Read and save the vehicle specification (TYPE ID).• Write the vehicle specification (TYPE ID) when replacing ABS actuator and electric unit (control unit).

*: The following diagnosis information is erased by erasing:

- DTC
- Freeze frame data (FFD)

ECU IDENTIFICATION

ABS actuator and electric unit (control unit) part number can be read.

SELF DIAGNOSTIC RESULT

Refer to [BRC-51, "DTC Index"](#).

When "CRNT" is displayed on self-diagnosis result

- The system is presently malfunctioning.

When "PAST" is displayed on self-diagnosis result

- System malfunction in the past was detected, but the system is presently normal.

Freeze frame data (FFD)

The following vehicle status is recorded when DTC is detected and is displayed on CONSULT.

Item name	Display item
IGN counter (0 – 39)	<p>The number of times that ignition switch is turned ON after the DTC is detected is displayed.</p> <ul style="list-style-type: none">• When "0" is displayed: It indicates that the system is presently malfunctioning.• When except "0" is displayed: It indicates that system malfunction in the past was detected, but the system is presently normal. <p>NOTE: Each time when ignition switch is turned OFF to ON, numerical number increases from 1 → 2 → 3...38 → 39. When the operation number of times exceeds 39, the number does not increase and "39" is displayed until self-diagnosis is erased.</p>

ACTIVE TEST

The active test is used to determine and identify details of a malfunction, based on self-diagnosis test results and data obtained in the Data Monitor. In response to instructions from CONSULT instead of those from ABS actuator and electric unit (control unit) on the vehicle, a drive signal is sent to the actuator to check its operation.

CAUTION:

- **Never perform Active Test while driving the vehicle.**
- **Always bleed air from brake system before active test.**
- **Never perform active test when system is malfunctioning.**

NOTE:

- When active test is performed while depressing the pedal, the pedal depressing stroke may change. This is not a malfunction.
- "TEST IS STOPPED" is displayed approximately 10 seconds after operation start.

DIAGNOSIS SYSTEM [ABS ACTUATOR AND ELECTRIC UNIT (CONTROL UNIT)]

< SYSTEM DESCRIPTION >

[WITHOUT ICC]

- When performing active test again after “TEST IS STOPPED” is displayed, select “BACK”.
- ABS warning lamp, brake warning lamp and VDC warning lamp may turn ON during active test. This is not a malfunction.

ABS IN Valve and ABS OUT Valve

When “Up”, “Keep” or “Down” is selected on display screen, the following items are displayed when system is normal:

Test item	Display Item	Display		
		Up	Keep	Down
FR RH SOL	FR RH IN SOL	Off	On*	On*
	FR RH OUT SOL	Off	Off	On*
FR LH SOL	FR LH IN SOL	Off	On*	On*
	FR LH OUT SOL	Off	Off	On*
RR RH SOL	RR RH IN SOL	Off	On*	On*
	RR RH OUT SOL	Off	Off	On*
RR LH SOL	RR LH IN SOL	Off	On*	On*
	RR LH OUT SOL	Off	Off	On*

*: Immediately after being selected, status is “On”. Status changes to “Off” after approximately 2 seconds.

ABS IN Valve (ACT) and ABS OUT Valve (ACT)

When “Up”, “ACT UP” or “ACT KEEP” is selected on display screen, the following items are displayed when system is normal.

Test item	Display Item	Display		
		Up	ACT UP	ACT KEEP
FR RH SOL (ACT)	FR RH IN SOL	Off	Off	Off
	FR RH OUT SOL	Off	Off	Off
	CV1	Off	On*	On*
	CV2	Off	On*	On*
FR LH SOL (ACT)	FR LH IN SOL	Off	Off	Off
	FR LH OUT SOL	Off	Off	Off
	CV1	Off	On*	On*
	CV2	Off	On*	On*
RR RH SOL (ACT)	RR RH IN SOL	Off	Off	Off
	RR RH OUT SOL	Off	Off	Off
	CV1	Off	On*	On*
	CV2	Off	On*	On*
RR LH SOL (ACT)	RR LH IN SOL	Off	Off	Off
	RR LH OUT SOL	Off	Off	Off
	CV1	Off	On*	On*
	CV2	Off	On*	On*

*: Immediately after being selected, status is “On”. Status changes to “Off” after approx. 10 seconds.

ABS MOTOR

When “On” or “Off” is selected on display screen, the following items are displayed when system is normal.

Test item	Display Item	Display	
		On	Off
ABS MOTOR	MOTOR RELAY	On	Off
	ACTUATOR RLY ^(Note)	On	On

DIAGNOSIS SYSTEM [ABS ACTUATOR AND ELECTRIC UNIT (CONTROL UNIT)]

< SYSTEM DESCRIPTION >

[WITHOUT ICC]

NOTE:

Display occasionally changes On/Off for a moment after ignition switch is turned ON. This is operation for checking purposes and is not a malfunction.

DATA MONITOR

NOTE:

The following table includes information (items) inapplicable to this vehicle. For information (items) applicable to this vehicle, refer to CONSULT display items.

×: Applicable

Item (Unit)	Monitor item selection		Note
	INPUT SIGNALS	MAIN SIGNALS	
FR LH SENSOR [km/h (MPH)]	×	×	Wheel speed calculated by front LH wheel sensor is displayed.
FR RH SENSOR [km/h (MPH)]	×	×	Wheel speed calculated by front RH wheel sensor is displayed.
RR LH SENSOR [km/h (MPH)]	×	×	Wheel speed calculated by rear LH wheel sensor is displayed.
RR RH SENSOR [km/h (MPH)]	×	×	Wheel speed calculated by rear RH wheel sensor is displayed.
DECEL G-SEN (m/s ²)	×	×	Decel G detected by decel G sensor is displayed.
FR RH IN SOL (On/Off)		×	Operation status of front RH wheel ABS IN valve is displayed.
FR RH OUT SOL (On/Off)		×	Operation status of front RH wheel ABS OUT valve is displayed.
FR LH IN SOL (On/Off)		×	Operation status of front LH wheel ABS IN valve is displayed.
FR LH OUT SOL (On/Off)		×	Operation status of front LH wheel ABS OUT valve is displayed.
RR RH IN SOL (On/Off)		×	Operation status of rear RH wheel ABS IN valve is displayed.
RR RH OUT SOL (On/Off)		×	Operation status of rear RH wheel ABS OUT valve is displayed.
RR LH IN SOL (On/Off)		×	Operation status of rear LH wheel ABS IN valve is displayed.
RR LH OUT SOL (On/Off)		×	Operation status of rear LH wheel ABS OUT valve is displayed.
EBD WARN LAMP (On/Off)			Brake warning lamp ON/OFF status is displayed. (Note 1)
STOP LAMP SW (On/Off)	×	×	Stop lamp switch signal input status is displayed.
MOTOR RELAY (On/Off)		×	ABS motor and motor relay status is displayed.
ACTUATOR RLY (On/Off)		×	ABS actuator relay status is displayed.
ABS WARN LAMP (On/Off)		×	ABS warning lamp ON/OFF status is displayed. (Note 1)
OFF LAMP (On/Off)		×	VDC OFF indicator lamp ON/OFF status is displayed. (Note 1)
OFF SW (On/Off)	×	×	VDC OFF switch status is displayed.
SLIP/VDC LAMP (On/Off)		×	VDC warning lamp ON/OFF status is displayed. (Note 1)
BATTERY VOLT (V)	×	×	Voltage supplied to ABS actuator and electric unit (control unit) is displayed.

DIAGNOSIS SYSTEM [ABS ACTUATOR AND ELECTRIC UNIT (CONTROL UNIT)]

< SYSTEM DESCRIPTION >

[WITHOUT ICC]

Item (Unit)	Monitor item selection		Note
	INPUT SIGNALS	MAIN SIGNALS	
GEAR	×	×	Current gear position judged from current gear position signal is displayed.
ENGINE SPEED (tr/min)	×	×	Engine speed status is displayed.
YAW RATE SEN (d/s)	×	×	Yaw rate detected by yaw rate sensor is displayed.
R POSI SIG (On/Off)			R range signal input status judged from R range signal is displayed.
4WD MODE MON ^(Note 2) (AUTO/LOCK/2WD)	×	×	AWD control status is displayed.
N POSI SIG (On/Off)			N range signal input status judged from N range signal is displayed.
P POSI SIG (On/Off)			P range signal input status judged from P range signal is displayed.
CV1 (On/Off)			Cut valve 1 status (On/Off) status is displayed
CV2 (On/Off)			Cut valve 2 status (On/Off) status is displayed
ACCEL POS SIG (%)	×		Displays the Accelerator pedal position
SIDE G-SENSOR (m/s ²)	×		Side G detected by side G sensor is displayed.
STR ANGLE SIG	×		Steering angle detected by steering angle sensor is displayed.
PRESS SENSOR (bar)	×		Brake fluid pressure detected by pressure sensor is displayed.
EBD SIGNAL (On/Off)			EBD operation status is displayed.
ABS SIGNAL (On/Off)			ABS operation status is displayed.
TCS SIGNAL (On/Off)			TCS operation status is displayed.
VDC SIGNAL (On/Off)			VDC operation status is displayed.
EBD FAIL SIG (On/Off)			EBD fail-safe signal status is displayed.
ABS FAIL SIG (On/Off)			ABS fail-safe signal status is displayed.
TCS FAIL SIG (On/Off)			TCS fail-safe signal status is displayed.
VDC FAIL SIG (On/Off)			VDC fail-safe signal status is displayed.
CRANKING SIG (On/Off)			Cranking status is displayed.
FLUID LEV SW (On/Off)	×		Brake fluid level signal input status via CAN communication is displayed.
USS SIG ^(Note 3) (On/Off)			hill start assist operation status is displayed.

Note 1: Refer to [MWI-9. "METER SYSTEM : System Description"](#) for ON/OFF conditions of each warning lamp and indicator lamp.

Note 2: AWD models

DIAGNOSIS SYSTEM [ABS ACTUATOR AND ELECTRIC UNIT (CONTROL UNIT)]

< SYSTEM DESCRIPTION >

[WITHOUT ICC]

Note 3: USS (Hill Start Assist)

WORK SUPPORT

Conditions	Description
ST ANGLE SENSOR ADJUSTMENT	Perform neutral position adjustment of steering angle sensor.
DECEL G SEN CALIBRATION	Perform decel G sensor calibration.

CONFIGURATION

Configuration includes the following functions.

Function		Description
Read/Write Configuration	Before replacing ECU	Allows the reading of vehicle specification (TYPE ID) written in the ABS actuator and electrical unit (control unit) to store the specification in CONSULT.
	After replacing ECU	Allows the writing of vehicle information (TYPE ID) stored in the CONSULT into the ABS actuator and electrical unit (control unit).
Manual Configuration		Allows the writing of vehicle specification (TYPE ID) stored in the ABS actuator and electrical unit (control unit) by hand.

CAUTION:

Use “Manual Configuration” “TYPE ID” of ABS actuator and electric unit (control unit) cannot be read.

A
B
C
D
E
BRC
G
H
I
J
K
L
M
N
O
P

ABS ACTUATOR AND ELECTRIC UNIT (CONTROL UNIT)

< ECU DIAGNOSIS INFORMATION >

[WITHOUT ICC]

ECU DIAGNOSIS INFORMATION

ABS ACTUATOR AND ELECTRIC UNIT (CONTROL UNIT)

Reference Value

INFOID:000000012894401

VALUES ON THE DIAGNOSIS TOOL

CAUTION:

The display shows the control unit calculation data, so a normal value might be displayed even in the event the output circuit (harness) is open or short-circuited.

Monitor item	Display content	Data monitor	
		Condition	Reference value in normal operation
FR LH SENSOR	Wheel speed	0 [km/h, mph]	Vehicle stopped
		Nearly matches the speed meter display (± 10% or less)	Vehicle running (Note 1)
FR RH SENSOR	Wheel speed	0 [km/h, mph]	Vehicle stopped
		Nearly matches the speed meter display (± 10% or less)	Vehicle running (Note 1)
RR LH SENSOR	Wheel speed	0 [km/h, mph]	Vehicle stopped
		Nearly matches the speed meter display (± 10% or less)	Vehicle running (Note 1)
RR RH SENSOR	Wheel speed	0 [km/h, mph]	Vehicle stopped
		Nearly matches the speed meter display (± 10% or less)	Vehicle running (Note 1)
DECEL G-SEN	Longitudinal acceleration detected by decel G sensor	Vehicle stopped	Approx. 0 G
		Vehicle running	-1.7 to 1.7 G
FR RH IN SOL	Operation status of all solenoid valves	Actuator (solenoid valve) is active ("ACTIVE TEST" with CONSULT) or actuator relay is inactive (in fail-safe mode)	On
		When the actuator (solenoid valve) is not active and actuator relay is active (ignition switch ON)	Off
FR RH OUT SOL	Operation status of all solenoid valves	Actuator (solenoid valve) is active ("ACTIVE TEST" with CONSULT) or actuator relay is inactive (in fail-safe mode)	On
		When the actuator (solenoid valve) is not active and actuator relay is active (ignition switch ON)	Off
FR LH IN SOL	Operation status of all solenoid valves	Actuator (solenoid valve) is active ("ACTIVE TEST" with CONSULT) or actuator relay is inactive (in fail-safe mode)	On
		When the actuator (solenoid valve) is not active and actuator relay is active (ignition switch ON)	Off
FR LH OUT SOL	Operation status of all solenoid valves	Actuator (solenoid valve) is active ("ACTIVE TEST" with CONSULT) or actuator relay is inactive (in fail-safe mode)	On
		When the actuator (solenoid valve) is not active and actuator relay is active (ignition switch ON)	Off

ABS ACTUATOR AND ELECTRIC UNIT (CONTROL UNIT)

< ECU DIAGNOSIS INFORMATION >

[WITHOUT ICC]

Monitor item	Display content	Data monitor	
		Condition	Reference value in normal operation
RR RH IN SOL	Operation status of all solenoid valves	Actuator (solenoid valve) is active ("ACTIVE TEST" with CONSULT) or actuator relay is inactive (in fail-safe mode)	On
		When the actuator (solenoid valve) is not active and actuator relay is active (ignition switch ON)	Off
RR RH OUT SOL	Operation status of all solenoid valves	Actuator (solenoid valve) is active ("ACTIVE TEST" with CONSULT) or actuator relay is inactive (in fail-safe mode)	On
		When the actuator (solenoid valve) is not active and actuator relay is active (ignition switch ON)	Off
RR LH IN SOL	Operation status of all solenoid valves	Actuator (solenoid valve) is active ("ACTIVE TEST" with CONSULT) or actuator relay is inactive (in fail-safe mode)	On
		When the actuator (solenoid valve) is not active and actuator relay is active (ignition switch ON)	Off
RR LH OUT SOL	Operation status of all solenoid valves	Actuator (solenoid valve) is active ("ACTIVE TEST" with CONSULT) or actuator relay is inactive (in fail-safe mode)	On
		When the actuator (solenoid valve) is not active and actuator relay is active (ignition switch ON)	Off
EBD WARN LAMP	EBD warning lamp (Note 2)	When EBD warning lamp is ON	On
		When EBD warning lamp is OFF	Off
STOP LAMP SW	Brake pedal operation	When brake pedal is depressed	On
		When brake pedal is not depressed	Off
MOTOR RELAY	Motor and motor relay operation	When the motor relay and motor are operating	On
		When the motor relay and motor are not operating	Off
ACTUATOR RLY	Actuator relay operation	When the actuator relay is operating	On
		When the actuator relay is not operating	Off
ABS WARN LAMP	ABS warning lamp (Note 2)	When ABS warning lamp is ON	On
		When ABS warning lamp is OFF	Off
OFF LAMP	VDC OFF indicator lamp (Note 2)	When VDC OFF indicator lamp is ON	On
		When VDC OFF indicator lamp is OFF	Off
OFF SW	VDC OFF switch	When VDC OFF switch is ON	On
		When VDC OFF switch is OFF	Off
SLIP/VDC LAMP	SLIP indicator lamp (Note 2)	When SLIP indicator lamp is ON	On
		When SLIP indicator lamp is OFF	Off
BATTERY VOLT	Battery voltage supplied to the ABS actuator and electric unit (control unit)	Ignition switch ON	10 – 16 V
GEAR	Manual mode gear position determined by TCM	1st gear 2nd gear 3rd gear 4th gear 5th gear	1 2 3 4 5

A
B
C
D
E
BRC
G
H
I
J
K
L
M
N
O
P

ABS ACTUATOR AND ELECTRIC UNIT (CONTROL UNIT)

< ECU DIAGNOSIS INFORMATION >

[WITHOUT ICC]

Monitor item	Display content	Data monitor	
		Condition	Reference value in normal operation
ENGINE SPEED	With engine running	With engine stopped	0 RPM
		Engine running	Almost in accordance with tachometer display
YAW RATE SEN	Yaw rate detected by yaw rate/side G sensor	Vehicle stopped	Approx. 0 d/s
		Vehicle turning	-75 to 75 d/s
R POSI SIG	Transmission range switch signal ON/OFF condition	CVT shift position = R position	On
		CVT shift position = other than R position	Off
4WD MODE MON	Always (Note 3)	AUTO, LOCK, AWD	AUTO, LOCK, AWD (depending on AWD control status)
N POSI SIG	Transmission range switch signal ON/OFF condition	CVT shift position = N position	On
		CVT shift position = other than N position	Off
CV1	Cut valve 1 signal	When cut valve 1 is open or closed	On
			Off
CV2	Cut valve 2 signal	When cut valve 2 is open or closed	On
			Off
ACCEL POS SIG	Throttle actuator opening/closing is displayed (linked with accelerator pedal)	Accelerator pedal not depressed (ignition switch is ON)	0 %
		Depress accelerator pedal (ignition switch is ON)	0 - 100 %
SIDE G-SENSOR	Transverse G detected by side G sensor	Vehicle stopped	Approx. 0 m/s ²
		Vehicle turning right	Negative value (m/s ²)
		Vehicle turning left	Positive value (m/s ²)
STR ANGLE SIG	Steering angle detected by steering angle sensor	Straight-ahead	Approx. 0°
		Steering wheel turned	-720 to 720°
PRESS SENSOR	Brake fluid pressure detected by pressure sensor	With ignition switch turned ON and brake pedal released	Approx. 0 bar
		With ignition switch turned ON and brake pedal depressed	-40 to 300 bar (Pressure increases according to pedal effort.)
EBD SIGNAL	EBD operation	EBD is active	On
		EBD is inactive	Off
ABS SIGNAL	ABS operation	ABS is active	On
		ABS is inactive	Off
TCS SIGNAL	TCS operation	TCS is active	On
		TCS is inactive	Off
VDC SIGNAL	VDC operation	VDC is active	On
		VDC is inactive	Off
EBD FAIL SIG	EBD fail-safe signal	In EBD fail-safe	On
		EBD is normal	Off
ABS FAIL SIG	ABS fail-safe signal	In ABS fail-safe	On
		ABS is normal	Off

ABS ACTUATOR AND ELECTRIC UNIT (CONTROL UNIT)

< ECU DIAGNOSIS INFORMATION >

[WITHOUT ICC]

Monitor item	Display content	Data monitor	
		Condition	Reference value in normal operation
TCS FAIL SIG	TCS fail-safe signal	In TCS fail-safe	On
		TCS is normal	Off
VDC FAIL SIG	VDC fail-safe signal	In VDC fail-safe	On
		VDC is normal	Off
CRANKING SIG	Crank operation	Crank is active	On
		Crank is inactive	Off
FLUID LEV SW	Brake fluid level switch	When brake fluid level switch ON	On
		When brake fluid level switch OFF	Off
USS SIG (On/Off)	Hill start assist status (Note 4)	When hill start assist is active	On
		When hill start assist is not active	Off

Note 1: Confirm tire pressure is normal.

Note 2: On and off timing for warning lamps and indicator lamps.

Note 3: AWD models

Note 4: USS (Hill Start Assist)

- Refer to [BRC-28, "VDC FUNCTION : System Description"](#).
- Refer to [BRC-30, "TCS FUNCTION : System Description"](#).
- Refer to [BRC-32, "ABS FUNCTION : System Description"](#).
- Refer to [BRC-34, "EBD FUNCTION : System Description"](#).

Fail-Safe

INFOID:000000012894402

VDC FUNCTION, TCS FUNCTION, BRAKE ASSIST FUNCTION AND HILL START ASSIST FUNCTION

VDC warning lamp in combination meter turns ON when a malfunction occurs in system [ABS actuator and electric unit (control unit)]. The control is suspended for VDC function, TCS function, brake assist function and hill start assist function. The vehicle status becomes the same as models without VDC function, TCS function, brake assist function and hill start assist function. However, ABS function and EBD function operate normally.

ABS FUNCTION

ABS warning lamp and VDC warning lamp in combination meter turn ON when a malfunction occurs in system [ABS actuator and electric unit (control unit)]. The control is suspended for VDC function, TCS function, ABS function, brake assist function and hill start assist function. The vehicle status becomes the same as models without VDC function, TCS function, ABS function, brake assist function and hill start assist function. However, EBD function operates normally.

NOTE:

ABS self-diagnosis sound may be heard the same as in the normal condition, because self-diagnosis is performed when ignition switch turns ON and when vehicle initially starts.

EBD FUNCTION

ABS warning lamp, brake warning lamp and VDC warning lamp in combination meter turn ON when a malfunction occurs in system [ABS actuator and electric unit (control unit)]. The control is suspended for VDC function, TCS function, ABS function, EBD function, brake assist function and hill start assist function. The vehicle status becomes the same as models without VDC function, TCS function, ABS function, EBD function, brake assist function and hill start assist function.

ABS ACTUATOR AND ELECTRIC UNIT (CONTROL UNIT)

< ECU DIAGNOSIS INFORMATION >

[WITHOUT ICC]

DTC	Fail-safe condition
C1101	The following functions are suspended: <ul style="list-style-type: none"> • VDC function • TCS function • ABS function • EBD function (only when both rear wheels are malfunctioning) • Brake assist function • Hill start assist function
C1102	
C1103	
C1104	
C1105	
C1106	
C1107	
C1108	
C1109	The following functions are suspended: <ul style="list-style-type: none"> • VDC function • TCS function • ABS function • EBD function • Brake assist function • Hill start assist function
C1110	
C1111	The following functions are suspended: <ul style="list-style-type: none"> • VDC function • TCS function • ABS function • Brake assist function • Hill start assist function
C1113	The following functions are suspended: <ul style="list-style-type: none"> • VDC function • TCS function • ABS function¹ • Brake assist function¹ • Hill start assist function
C1115	The following functions are suspended: <ul style="list-style-type: none"> • VDC function • TCS function • ABS function • EBD function • Brake assist function • Hill start assist function
C1116	The following functions are suspended: <ul style="list-style-type: none"> • VDC function • TCS function • Brake assist function • Hill start assist function
C1120	The following functions are suspended: <ul style="list-style-type: none"> • VDC function • TCS function • ABS function • EBD function • Brake assist function • Hill start assist function
C1121	
C1122	
C1123	
C1124	
C1125	
C1126	
C1127	
C1130	The following functions are suspended: <ul style="list-style-type: none"> • VDC function • TCS function • Hill start assist function

ABS ACTUATOR AND ELECTRIC UNIT (CONTROL UNIT)

< ECU DIAGNOSIS INFORMATION >

[WITHOUT ICC]

DTC	Fail-safe condition	
		A
C1140	The following functions are suspended: <ul style="list-style-type: none"> • VDC function • TCS function • ABS function • EBD function • Brake assist function • Hill start assist function 	B
C1142	The following functions are suspended: <ul style="list-style-type: none"> • VDC function • TCS function • Brake assist function • Hill start assist function 	C
C1143	The following functions are suspended: <ul style="list-style-type: none"> • VDC function • TCS function • Hill start assist function 	D
C1144		E
C1145	The following functions are suspended: <ul style="list-style-type: none"> • VDC function • TCS function • ABS function¹ • Brake assist function¹ • Hill start assist function 	BRC
C1146		G
C1153	The following functions are suspended: <ul style="list-style-type: none"> • VDC function • TCS function • ABS function • Brake assist function • Hill start assist function 	H
C1154	The following functions are suspended: <ul style="list-style-type: none"> • VDC function • TCS function • Hill start assist function 	I
C1155	The following functions are suspended: <ul style="list-style-type: none"> • VDC function • TCS function • Brake assist function • Hill start assist function 	J
C1160	The following functions are suspended: <ul style="list-style-type: none"> • VDC function • TCS function • ABS function¹ • Brake assist function¹ • Hill start assist function 	K
C1164	The following functions are suspended: <ul style="list-style-type: none"> • VDC function • TCS function • ABS function • EBD function • Brake assist function • Hill start assist function 	L
C1165		M
C1166		N
C1167		O
C1170		P
C1197		
C1198	Electrical vacuum assistance of brake booster is suspended.	
C1199	Normal control	
C119A	Electrical vacuum assistance of brake booster is suspended.	

ABS ACTUATOR AND ELECTRIC UNIT (CONTROL UNIT)

< ECU DIAGNOSIS INFORMATION >

[WITHOUT ICC]

DTC	Fail-safe condition
U1000	The following functions are suspended: <ul style="list-style-type: none"> • VDC function • TCS function • Brake assist function • Hill start assist function
U1002	

¹: AWD models

DTC Inspection Priority Chart

INFOID:000000012894403

When multiple DTCs are displayed simultaneously, check one by one depending on the following priority list:

Priority	Detected item (DTC)
1	<ul style="list-style-type: none"> • U1000 CAN COMM CIRCUIT • U1002 SYSTEM COMM (CAN)
2	<ul style="list-style-type: none"> • C1110 CONTROLLER FAILURE • C1153 EMERGENCY BRAKE • C1170 VARIANT CODING
3	<ul style="list-style-type: none"> • C1130 ENGINE SIGNAL 1 • C1144 ST ANG SEN SIGNAL
4	<ul style="list-style-type: none"> • C1109 BATTERY VOLTAGE [ABNORMAL] • C1111 PUMP MOTOR • C1140 ACTUATOR RLY
5	<ul style="list-style-type: none"> • C1101 RR RH SENSOR-1 • C1102 RR LH SENSOR-1 • C1103 FR RH SENSOR-1 • C1104 FR LH SENSOR-1 • C1105 RR RH SENSOR-2 • C1106 RR LH SENSOR-2 • C1107 FR RH SENSOR-2 • C1108 FR LH SENSOR-2 • C1113 G SENSOR • C1115 ABS SENSOR [ABNORMAL] • C1116 STOP LAMP SW • C1120 FR LH IN ABS SOL • C1121 FR LH OUT ABS SOL • C1122 FR RH IN ABS SOL • C1123 FR RH OUT ABS SOL • C1124 RR LH IN ABS SOL • C1125 RR LH OUT ABS SOL • C1126 RR RH IN ABS SOL • C1127 RR RH OUT ABS SOL • C1142 PRESS SEN CIRCUIT • C1143 ST ANG SEN CIRCUIT • C1145 YAW RATE SENSOR • C1146 SIDE G SEN CIRCUIT • C1154 PNP POS SIG • C1160 DECEL G SEN SET • C1164 CV 1 • C1165 CV 2 • C1166 SV 1 • C1167 SV 2 • C1197 VACUUM SENSOR • C1198 VACUUM SEN CIR • C1199 BRAKE BOOSTER • C119A VACUUM SEN VOLT
6	<ul style="list-style-type: none"> • C1155 BR FLUID LEVEL LOW

ABS ACTUATOR AND ELECTRIC UNIT (CONTROL UNIT)

< ECU DIAGNOSIS INFORMATION >

[WITHOUT ICC]

DTC Index

INFOID:000000012894404

DTC	Items (CONSULT screen terms)	Reference
C1101	RR RH SENSOR-1	BRC-68, "DTC Description"
C1102	RR LH SENSOR-1	
C1103	FR RH SENSOR-1	
C1104	FR LH SENSOR-1	
C1105	RR RH SENSOR-2	BRC-73, "DTC Description"
C1106	RR LH SENSOR-2	
C1107	FR RH SENSOR-2	
C1108	FR LH SENSOR-2	
C1109	BATTERY VOLTAGE [ABNORMAL]	BRC-80, "DTC Description"
C1110	CONTROLLER FAILURE	BRC-82, "DTC Description"
C1111	PUMP MOTOR	BRC-84, "DTC Description"
C1113	G SENSOR	BRC-87, "DTC Description"
C1115	ABS SENSOR [ABNORMAL SIGNAL]	BRC-89, "DTC Description"
C1116	STOP LAMP SW	BRC-96, "DTC Description"
C1120	FR LH IN ABS SOL	BRC-102, "DTC Description"
C1121	FR LH OUT ABS SOL	BRC-104, "DTC Description"
C1122	FR RH IN ABS SOL	BRC-102, "DTC Description"
C1123	FR RH OUT ABS SOL	BRC-104, "DTC Description"
C1124	RR LH IN ABS SOL	BRC-102, "DTC Description"
C1125	RR LH OUT ABS SOL	BRC-104, "DTC Description"
C1126	RR RH IN ABS SOL	BRC-102, "DTC Description"
C1127	RR RH OUT ABS SOL	BRC-104, "DTC Description"
C1130	ENGINE SIGNAL 1	BRC-106, "DTC Description"
C1140	ACTUATOR RLY	BRC-108, "DTC Description"
C1142	PRESS SEN CIRCUIT	BRC-110, "DTC Description"
C1143	ST ANG SEN CIRCUIT	BRC-113, "DTC Description"
C1144	ST ANG SEN SIGNAL	BRC-117, "DTC Description"
C1145	YAW RATE SENSOR	BRC-87, "DTC Description"
C1146	SIDE G-SEN CIRCUIT	
C1153	EMERGENCY BRAKE	BRC-82, "DTC Description"
C1154	PNP POSI SIG	BRC-119, "DTC Description"
C1155	BR FLUID LEVEL LOW	BRC-121, "DTC Description"
C1160	DECEL G SEN SET	BRC-125, "DTC Description"
C1164	CV 1	BRC-127, "DTC Description"
C1165	CV 2	
C1166	SV 1	
C1167	SV 2	BRC-129, "DTC Description"
C1170	VARIANT CODING	BRC-131, "DTC Description"
C1197	VACUUM SENSOR	BRC-133, "DTC Description"
C1198	VACUUM SEN CIR	BRC-136, "DTC Description"
C1199	BRAKE BOOSTER	BRC-138, "DTC Description"
C119A	VACUUM SEN VOLT	BRC-141, "DTC Description"

A
B
C
D
E
G
H
I
J
K
L
M
N
O
P

BRC

ABS ACTUATOR AND ELECTRIC UNIT (CONTROL UNIT)

< ECU DIAGNOSIS INFORMATION >

[WITHOUT ICC]

DTC	Items (CONSULT screen terms)	Reference
U1000	CAN COMM CIRCUIT	BRC-144, "DTC Description"
U1002	SYSTEM COMM (CAN)	BRC-145, "DTC Description"

BRAKE CONTROL SYSTEM

< WIRING DIAGRAM >

[WITHOUT ICC]

BRAKE CONTROL SYSTEM CONNECTORS - WITHOUT INTELLIGENT CRUISE CONTROL

Connector No.	M4
Connector Name	FUSE BLOCK (J/B)
Connector Type	NS16FW-CS
Connector Color	WHITE

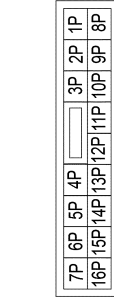

Terminal No.	Color of Wire	Signal Name
8P	BG	-
13P	W	-

Connector No.	M23
Connector Name	COMBINATION METER
Connector Type	TH16FW-NH
Connector Color	WHITE

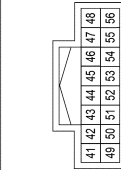

Terminal No.	Color of Wire	Signal Name
43	B	GND1
44	BG	POWER (IGN)
45	B	GND2
46	W	POWER (BAT)
52	P	CAN-L
53	L	CAN-H

Connector No.	M24
Connector Name	COMBINATION METER
Connector Type	TH40FW-NH
Connector Color	WHITE

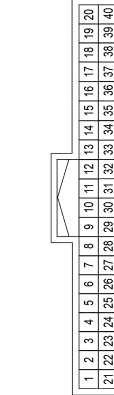

Terminal No.	Color of Wire	Signal Name
25	G	BRAKE OIL SW
26	BR	PKB SW

Connector No.	M31
Connector Name	WIRE TO WIRE
Connector Type	TH80FW-CS16-TM4
Connector Color	WHITE

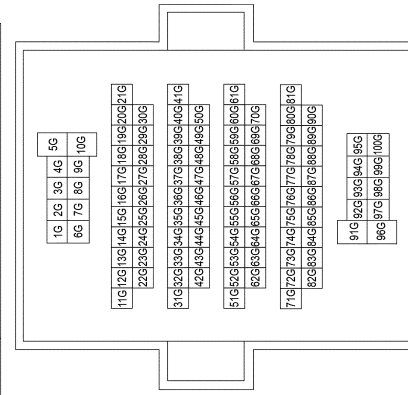

Terminal No.	Color of Wire	Signal Name
13G	BR	-
16G	G	-
39G	W	-
40G	B	-
41G	P	-
42G	V	-
46G	P	-

47G	G	-
Connector No.	M54	
Connector Name	STEERING ANGLE SENSOR	
Connector Type	TH08FW-NH	
Connector Color	WHITE	

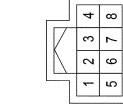

Terminal No.	Color of Wire	Signal Name
1	GR	STEERING SENSOR GND
2	P	CAN-L
4	G	STEERING SENSOR POWER SUPPLY
5	L	CAN-H

Connector No.	M71
Connector Name	VDC OFF SWITCH
Connector Type	TH08FB-NH
Connector Color	BLACK

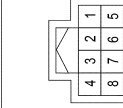

Terminal No.	Color of Wire	Signal Name
6	P	-
8	B	-

BRAKE CONTROL SYSTEM

< WIRING DIAGRAM >

[WITHOUT ICC]

2	Y	-
Connector No.	E44	
Connector Name	JOINT CONNECTOR-E01	
Connector Type	BJ30FW	
Connector Color	WHITE	

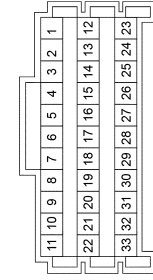

Terminal No.	Color of Wire	Signal Name
19	W	-
20	W	-
24	P	-
26	P	-

Connector No.	E52
Connector Name	PARKING BRAKE SWITCH
Connector Type	P01FB-A
Connector Color	BLACK



Terminal No.	Color of Wire	Signal Name
1	LG	-

2	B	-
Connector No.	E28	
Connector Name	FUSE BLOCK (J/B)	
Connector Type	NS10FW-CS	
Connector Color	WHITE	

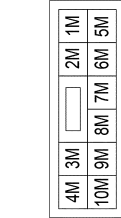

Terminal No.	Color of Wire	Signal Name
5M	W	-

Connector No.	E38
Connector Name	STOP LAMP SWITCH
Connector Type	M04FW-LC
Connector Color	WHITE



Terminal No.	Color of Wire	Signal Name
1	W	-
2	P	-

Connector No.	E43
Connector Name	FRONT WHEEL SENSOR RH
Connector Type	RH02MB
Connector Color	BLACK



Terminal No.	Color of Wire	Signal Name
1	L	-

Connector No.	M84
Connector Name	WIRE TO WIRE
Connector Type	TH32FW-NH
Connector Color	WHITE

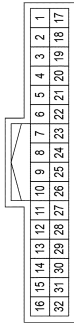

Terminal No.	Color of Wire	Signal Name
23	V	-
24	P	-
25	B	-
26	W	-

Connector No.	E18
Connector Name	FRONT WHEEL SENSOR LH
Connector Type	RH02MB
Connector Color	BLACK



Terminal No.	Color of Wire	Signal Name
1	G	-
2	W	-

Connector No.	E21
Connector Name	BRAKE FLUID LEVEL SWITCH
Connector Type	YV02FGY
Connector Color	GRAY



Terminal No.	Color of Wire	Signal Name
1	W	-

AAFIA0483GB

A
B
C
D
E
BRC
G
H
I
J
K
L
M
N
O
P

BRAKE CONTROL SYSTEM

< WIRING DIAGRAM >

[WITHOUT ICC]

46G	R	-
47G	BR	-

Connector No.	E167
Connector Name	VACUUM SENSOR
Connector Type	RH03FB
Connector Color	BLACK

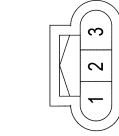

Terminal No.	Color of Wire	Signal Name
1	W	-
2	SHIELD	-
3	B	-

Connector No.	C10
Connector Name	REAR WHEEL SENSOR LH
Connector Type	RH02MB
Connector Color	BLACK

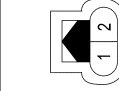

Terminal No.	Color of Wire	Signal Name
1	B	-
2	W	-

20	-	-
21	-	-
22	-	-
23	-	-
24	SHIELD	GND EXT
25	R	UB VR
26	L	CAN-H
27	-	-
28	BR	WAU
29	SB	WSS RR
30	P	BLS
31	R	WSP RL
32	-	-
33	-	-
34	-	-
35	-	-
36	-	-
37	-	-
38	B	GND ECU

Connector No.	E152
Connector Name	WIRE TO WIRE
Connector Type	TH80MW-CS16-TM4
Connector Color	WHITE

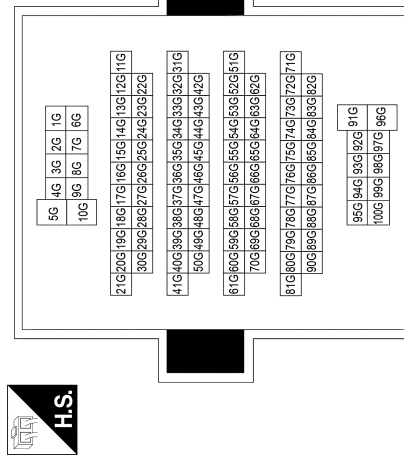

Terminal No.	Color of Wire	Signal Name
13G	LG	-
16G	W	-
38G	SB	-
40G	R	-
41G	SB	-
42G	V	-

Connector No.	E119
Connector Name	IPDM E/R (INTELLIGENT POWER DISTRIBUTION MODULE ENGINE ROOM)
Connector Type	TH32FW-NH
Connector Color	WHITE

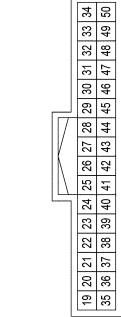

Terminal No.	Color of Wire	Signal Name
35	BR	ABS ECU

Connector No.	E125
Connector Name	ABS ACTUATOR AND ELECTRIC UNIT (CONTROL UNIT) (WITHOUT INTELLIGENT CRUISE CONTROL)
Connector Type	BE234FB-BHY2-BJZ2-LH
Connector Color	BLACK

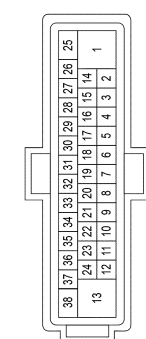

Terminal No.	Color of Wire	Signal Name
1	W	UB MR
2	-	-
3	-	-
4	Y	WSS FR
5	B	USV EXT
6	-	-
7	-	-
8	W	WSS FL
9	-	-
10	-	-
11	-	-
12	W	VAC
13	B/W	GND MR
14	P	CAN-L
15	R	VDC OFF
16	L	WSP FR
17	V	WSP RR
18	SB	WSS RL
19	G	WSP FL

AAFIA0484GB

BRAKE CONTROL SYSTEM

< WIRING DIAGRAM >

[WITHOUT ICC]

A
B
C
D
E
F
G
H
I
J
K
L
M
N
O
P

BRC

24	P	-
25	B	-
26	W	-

Connector No.	B131
Connector Name	WIRE TO WIRE
Connector Type	RH12FB
Connector Color	BLACK

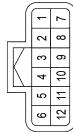

Terminal No.	Color of Wire	Signal Name
7	W	-
8	B	-
9	P	-
10	V	-

Connector No.	C11
Connector Name	REAR WHEEL SENSOR RH
Connector Type	RH02MGY
Connector Color	GRAY



Terminal No.	Color of Wire	Signal Name
1	V	-
2	P	-

Connector No.	C13
Connector Name	WIRE TO WIRE
Connector Type	RH12MB
Connector Color	BLACK

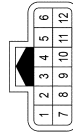

Terminal No.	Color of Wire	Signal Name
7	W	-
8	B	-
9	P	-
10	V	-

Connector No.	B101
Connector Name	WIRE TO WIRE
Connector Type	TH32MW-NH
Connector Color	WHITE

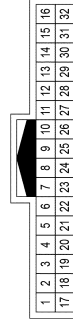

Terminal No.	Color of Wire	Signal Name
23	V	-

AAFIA0485GB

BASIC INSPECTION

DIAGNOSIS AND REPAIR WORK FLOW

Work Flow

INFOID:000000012894406

DETAILED FLOW

1. INTERVIEW THE CUSTOMER

Clarify customer concerns before inspection. First of all, perform an interview utilizing [BRC-59, "Diagnostic Work Sheet"](#) and reproduce the symptom as well as fully understand it. Ask customer about his/her concerns carefully. Check symptoms by driving vehicle with customer, if necessary.

CAUTION:

Customers are not professional. Never guess easily like "maybe the customer means that..." or "maybe the customer mentions this symptom".

>> GO TO 2.

2. CHECK SYMPTOM

Reproduce the symptom that is indicated by the customer, based on the information from the customer obtained in the interview. Also check that the symptom is not caused by fail-safe mode. Refer to [BRC-47, "Fail-Safe"](#).

CAUTION:

When the symptom is caused by normal operation, fully inspect each portion and obtain the understanding of customer that the symptom is not caused by a malfunction.

>> GO TO 3.

3. PERFORM THE SELF-DIAGNOSIS

ⓐ With CONSULT

1. Turn the ignition switch OFF → ON.

CAUTION:

Be sure to wait of 10 seconds after turning ignition switch OFF or ON.

2. Perform "Self Diagnostic Result" of "ABS".

Is DTC detected?

YES >> Record or print Self Diagnostic Results and Freeze Frame Data (FFD). GO TO 4.

NO >> GO TO 6.

4. RECHECK THE SYMPTOM

ⓐ With CONSULT

1. Erase "Self Diagnostic Result" of "ABS".
2. Turn the ignition switch OFF → ON → OFF.

CAUTION:

Be sure to wait of 10 seconds after turning ignition switch OFF or ON.

3. Perform DTC confirmation procedures for the malfunctioning system.

NOTE:

If some DTCs are detected at the same time, determine the order for performing the diagnosis based on [BRC-50, "DTC Inspection Priority Chart"](#).

Is DTC detected?

YES >> GO TO 5.

NO >> Check harness and connectors based on the information obtained in the interview. Refer to [GI-42, "Intermittent Incident"](#).

5. REPAIR OR REPLACE MALFUNCTIONING COMPONENT

1. Repair or replace malfunctioning components.
2. Reconnect component or connector after repairing or replacing.
3. When DTC is detected, erase "Self Diagnostic Result" of "ABS".

CAUTION:

DIAGNOSIS AND REPAIR WORK FLOW

< BASIC INSPECTION >

[WITHOUT ICC]

- Turn the ignition switch OFF → ON → OFF after erasing Self Diagnostic Result.
- Be sure to wait of 10 seconds after turning ignition switch OFF or ON.

>> GO TO 7.

6. IDENTIFY MALFUNCTIONING SYSTEM BY SYMPTOM DIAGNOSIS

Identify malfunctioning system based on symptom diagnosis and perform inspection.

Can the malfunctioning system be identified?

YES >> GO TO 7.

NO >> Check harness and connectors based on the information obtained in the interview. Refer to [GI-42, "Intermittent Incident"](#).

7. FINAL CHECK

④ With CONSULT

1. Select "DATA MONITOR" of "ABS"
2. Check the reference values. Refer to [BRC-44, "Reference Value"](#).
3. Recheck the symptom and check that the symptom is not reproduced on the same conditions.

Is the symptom reproduced?

YES >> GO TO 3.

NO >> Inspection End.

Diagnostic Work Sheet

INFOID:000000012894407

DESCRIPTION

- In general, customers have their own criteria for a problem. Therefore, it is important to understand the symptom and status well enough by asking the customer about his/her concerns carefully. To systemize all the information for the diagnosis, prepare the interview sheet referring to the interview points.
- In some cases, multiple conditions that appear simultaneously may cause a DTC to be detected.

INTERVIEW SHEET SAMPLE

Interview sheet							
Customer name		MR/MS	Registration number	Initial year registration			
			Vehicle type	VIN			
Storage date			Engine/traction Motor	Mileage	km (Mile)		
Symptom			<input type="checkbox"/> Does not operate () function				
			<input type="checkbox"/> Warning lamp turns ON.				
			ABS or BRAKE or <input type="checkbox"/> <input type="checkbox"/> OFF				
			<input type="checkbox"/> Other ()				
			<input type="checkbox"/> Noise (Location:)			<input type="checkbox"/> Vibration (Location:)	
<input type="checkbox"/> Other ()							
First occurrence			<input type="checkbox"/> Recently <input type="checkbox"/> Other ()				
Frequency of occurrence			<input type="checkbox"/> Always <input type="checkbox"/> Under a certain conditions of <input type="checkbox"/> Sometimes (time(s)/day)				
Climate conditions			<input type="checkbox"/> Irrelevant				
			Weather			<input type="checkbox"/> Fine <input type="checkbox"/> Cloud <input type="checkbox"/> Rain <input type="checkbox"/> Snow <input type="checkbox"/> Others ()	
			Temperature			<input type="checkbox"/> Hot <input type="checkbox"/> Warm <input type="checkbox"/> Cool <input type="checkbox"/> Cold <input type="checkbox"/> Temperature [Approx. °C (°F)]	
Relative humidity			<input type="checkbox"/> High <input type="checkbox"/> Moderate <input type="checkbox"/> Low				
Road conditions			<input type="checkbox"/> Ordinary road <input type="checkbox"/> Highway <input type="checkbox"/> Mountainous road (uphill or downhill) <input type="checkbox"/> Rough road				

DIAGNOSIS AND REPAIR WORK FLOW

< BASIC INSPECTION >

[WITHOUT ICC]

Interview sheet

Customer name	MR/MS	Registration number		Initial year registration	
		Vehicle type		VIN	
Storage date		Engine/traction Motor		Mileage	km (Mile)
Operating condition, etc.		<input type="checkbox"/> Irrelevant <input type="checkbox"/> When engine/traction motor starts <input type="checkbox"/> During idling <input type="checkbox"/> During driving <input type="checkbox"/> During acceleration <input type="checkbox"/> At constant speed driving <input type="checkbox"/> During deceleration <input type="checkbox"/> Immediately before stop [Vehicle speed: Approx. km/h (MPH)] <input type="checkbox"/> During cornering (right curve or left curve) <input type="checkbox"/> When steering wheel is steered (to right or to left)			
Other conditions	VDC OFF switch operation	<input type="checkbox"/> Yes <input type="checkbox"/> No			
	Use of other functions (ex. ICC)	<input type="checkbox"/> Yes <input type="checkbox"/> No ()			
	Presence of non-genuine parts installation	<input type="checkbox"/> Yes <input type="checkbox"/> No ()			
Memo					

ADDITIONAL SERVICE WHEN REPLACING ABS ACTUATOR AND ELECTRIC UNIT (CONTROL UNIT)

< BASIC INSPECTION >

[WITHOUT ICC]

ADDITIONAL SERVICE WHEN REPLACING ABS ACTUATOR AND ELECTRIC UNIT (CONTROL UNIT)

Description

INFOID:0000000012894408

- When replacing the ABS actuator and electric unit (control unit), perform configuration of the ABS actuator and electric unit (control unit). Refer to [BRC-66, "Work Procedure"](#).
- When replacing the ABS actuator and electric unit (control unit), adjust the neutral position of steering angle sensor. Refer to [BRC-62, "Work Procedure"](#).
- When replacing the ABS actuator and electric unit (control unit), perform calibration of the decel G sensor. Refer to [BRC-64, "Work Procedure"](#).

A
B
C
D
E
G
H
I
J
K
L
M
N
O
P

BRC

ADJUSTMENT OF STEERING ANGLE SENSOR NEUTRAL POSITION

< BASIC INSPECTION >

[WITHOUT ICC]

ADJUSTMENT OF STEERING ANGLE SENSOR NEUTRAL POSITION

Description

INFOID:000000012894409

Refer to the table below to determine if adjustment of steering angle sensor neutral position is required.

×: Required –: Not required

Situation	Adjustment of steering angle sensor neutral position
Removing/Installing ABS actuator and electric unit (control unit)	—
Replacing ABS actuator and electric unit (control unit)	×
Removing/Installing steering angle sensor	×
Replacing steering angle sensor	×
Removing/Installing steering components	×
Replacing steering components	×
Removing/Installing suspension components	—
Replacing suspension components	×
Changing tires to new ones	—
Tire rotation	—
Adjusting wheel alignment	×

Work Procedure

INFOID:000000012894410

ADJUSTMENT OF STEERING ANGLE SENSOR NEUTRAL POSITION

CAUTION:

**To adjust neutral position of steering angle sensor, make sure to use CONSULT.
(Adjustment cannot be done without CONSULT).**

1. ALIGN THE VEHICLE STATUS

Stop vehicle with front wheels in straight-ahead position.

>> GO TO 2.

2. PERFORM THE NEUTRAL POSITION ADJUSTMENT FOR THE STEERING ANGLE SENSOR

1. On the CONSULT screen, touch "Work support" and "ST ANGLE SENSOR ADJUSTMENT" in order.
2. Touch "Start".

CAUTION:

Do not touch steering wheel while adjusting steering angle sensor.

3. After approximately 10 seconds, touch "End".

NOTE:

After approximately 60 seconds, it ends automatically.

4. Turn ignition switch OFF then turn it ON again.

CAUTION:

Be sure to perform above operation.

>> GO TO 3.

3. CHECK DATA MONITOR

1. Run vehicle with front wheels in straight-ahead position then stop.
2. Select "Data Monitor". Then make sure "STR ANGLE SIG" is within $0 \pm 3.5^\circ$.

Is the steering angle within the specified range?

YES >> GO TO 4.

NO >> Perform the neutral position adjustment for the steering angle sensor again GO TO 1.

4. ERASE THE SELF DIAGNOSTIC RESULT MEMORY

Erase the "Self Diagnostic Result" memory of the ABS actuator and electric unit (control unit) and ECM.

- ABS actuator and electric unit (control unit): Refer to [BRC-39, "CONSULT Function"](#).

ADJUSTMENT OF STEERING ANGLE SENSOR NEUTRAL POSITION

< BASIC INSPECTION >

[WITHOUT ICC]

- ECM: Refer to [EC-70. "CONSULT Function"](#).

Are the memories erased?

YES >> Inspection End.

NO >> Check the items indicated by the "Self Diagnostic Result".

A

B

C

D

E

BRC

G

H

I

J

K

L

M

N

O

P

CALIBRATION OF DECEL G SENSOR

< BASIC INSPECTION >

[WITHOUT ICC]

CALIBRATION OF DECEL G SENSOR

Description

INFOID:000000012894411

CAUTION:

Always perform the decel G sensor calibration before driving when the following operation is performed.

NOTE:

Yaw rate/side/decel G sensor calibration is performed when performing the decel G sensor calibration.

×: Required —: Not required

Procedure	Decel G sensor calibration
Removing/ installing ABS actuator and electric unit (control unit)	—
Replacing ABS actuator and electric unit (control unit)	×
Removing/installing steering components	—
Replacing steering components	—
Removing/installing suspension components	—
Replacing suspension components	—
Removing/installing tire	—
Replacing tire	—
Tire rotation	—
Adjusting wheel alignment	—

Work Procedure

INFOID:000000012894412

DECEL G SENSOR CALIBRATION

CAUTION:

Always use CONSULT for the decel G sensor calibration. (It cannot be adjusted other than with CONSULT.)

NOTE:

Yaw rate/side/decel G sensor calibration is performed when performing the decel G sensor calibration.

1. CHECK THE VEHICLE STATUS

1. Steer the steering wheel to the straight-ahead position. Stop the vehicle on level surface.
2. Stop the engine.
3. Turn the ignition switch OFF.

Is the vehicle stopped in the straight-ahead position on level surface?

YES >> GO TO 2.

NO >> Steer the steering wheel to the straight-ahead position. Stop the vehicle on level surface.

2. PERFORM DECEL G SENSOR CALIBRATION

CAUTION:

- Never allow passenger or load on the vehicle.
- Never apply vibration to the vehicle body when opening or closing door during calibration.

CONSULT

1. Turn the ignition switch ON.

CAUTION:

Never start engine.

2. Select "ABS", "Work support", "DECEL G SEN CALIBRATION" in this order.
3. Select "Start".
4. After approx. 10 seconds, select "End".
5. Turn ignition switch OFF and then turn it ON again.

CAUTION:

Be sure to perform the operation above.

>> GO TO 3.

CALIBRATION OF DECEL G SENSOR

< BASIC INSPECTION >

[WITHOUT ICC]

3. CHECK DATA MONITOR

CONSULT

1. Drive the vehicle. Steer the steering wheel to the straight-ahead position. Stop the vehicle on level surface.
2. Select “ABS”, “Data Monitor”, “ECU INPUT SIGNALS” and “DECEL G SENSOR” in this order. Check that the signal is within the specified value.

DECEL G SENSOR : Approx. ± 0.01 G

Is the inspection result normal?

YES >> GO TO 4.

NO >> GO TO 1.

4. ERASE SELF DIAGNOSTIC RESULT MEMORY

CONSULT

Erase “Self Diagnostic Result” of “ABS”.

Are the memories erased?

YES >> Inspection End.

NO >> Check the items indicated by the “Self Diagnostic Result”.

A
B
C
D
E
G
H
I
J
K
L
M
N
O
P

BRC

CONFIGURATION [ABS ACTUATOR AND ELECTRIC UNIT (CONTROL UNIT)]

< BASIC INSPECTION >

[WITHOUT ICC]

CONFIGURATION [ABS ACTUATOR AND ELECTRIC UNIT (CONTROL UNIT)]

Work Procedure

INFOID:000000012894413

NOTE:

- After configuration, turn the ignition switch from OFF to ON and check that the VDC warning lamp turns OFF after staying illuminated for approximately two seconds.
- If an error occurs during configuration, start over from the beginning.

1. CHECK TYPE ID (1)

CONSULT

1. Using CONSULT, select "ECU Identification" of "ABS".
2. Write down "ECU PART NUMBER" displayed on the CONSULT screen. This is the ABS actuator and electric unit (control unit) "Type ID".

Is "Type ID" displayed?

YES-1 >> When replacing ABS actuator and electric unit (control unit): GO TO 3.

YES-2 >> When re-configuring existing ABS actuator and electric unit (control unit): GO TO 4.

NO >> GO TO 2.

2. CHECK TYPE ID (2)

1. Use FAST (service parts catalog) to search ABS actuator and electric unit (control unit) of the applicable vehicle and find "Type ID".
2. Write down "Type ID".

>> • When replacing ABS actuator and electric unit (control unit): GO TO 3.

• When re-configuring existing ABS actuator and electric unit (control unit): GO TO 4.

3. REPLACE ABS ACTUATOR AND ELECTRIC UNIT (CONTROL UNIT)

Replace ABS actuator and electric unit (control unit). Refer to [BRC-172. "Removal and Installation"](#).

CAUTION:

Do not perform the following work items at this time. These items must be performed after configuration is complete.

- Air bleeding
- Adjustment of steering angle sensor neutral position
- Calibration of decel G sensor

>> GO TO 4.

4. WRITE CONFIGURATION

CONSULT Configuration

1. Select "Manual Configuration".
2. Select the "Type ID" found using CONSULT "ECU Identification" or FAST (service parts catalog) to write the "Type ID" into the ABS actuator and electric unit (control unit).

>> GO TO 5.

5. VERIFY TYPE ID

Compare the "Type ID" written into the ABS actuator and electric unit (control unit) with the one found using CONSULT "ECU Identification" or FAST (service parts catalog) to confirm they match.

Do Type IDs match?

YES >> GO TO 6.

NO >> GO TO 4.

6. CHECK VDC WARNING LAMP

1. Turn the ignition switch OFF.
2. Turn the ignition switch ON and check that the VDC warning lamp turns OFF after staying illuminated for approximately two seconds.

CONFIGURATION [ABS ACTUATOR AND ELECTRIC UNIT (CONTROL UNIT)]

< BASIC INSPECTION >

[WITHOUT ICC]

NOTE:

Do not start the engine.

Is the inspection result normal?

YES >> GO TO 7.

NO >> Perform self-diagnosis of "ABS". Refer to [BRC-39, "CONSULT Function"](#).

7. PERFORM SUPPLEMENTARY WORK

1. Perform air bleeding. Refer to [BR-14, "Bleeding Brake System"](#).
2. Perform adjustment of steering angle sensor neutral position. Refer to [BRC-62, "Work Procedure"](#).
3. Perform calibration of decel G sensor. Refer to [BRC-64, "Work Procedure"](#).
4. Perform self-diagnosis of all systems.
5. Erase self-diagnosis results.

>> Work End.

A
B
C
D
E
G
H
I
J
K
L
M
N
O
P

BRC

C1101, C1102, C1103, C1104 WHEEL SENSOR

< DTC/CIRCUIT DIAGNOSIS >

[WITHOUT ICC]

DTC/CIRCUIT DIAGNOSIS

C1101, C1102, C1103, C1104 WHEEL SENSOR

DTC Description

INFOID:000000013444971

DTC DETECTION LOGIC

DTC	Display Item (Trouble diagnosis content)	Malfunction detected condition
C1101	RR RH SENSOR-1 (Rear RH wheel sensor-1)	When an open circuit is detected in rear RH wheel sensor circuit.
C1102	RR LH SENSOR-1 (Rear LH wheel sensor-1)	When an open circuit is detected in rear LH wheel sensor circuit.
C1103	FR RH SENSOR-1 (Front RH wheel sensor-1)	When an open circuit is detected in front RH wheel sensor circuit.
C1104	FR LH SENSOR-1 (Front LH wheel sensor-1)	When an open circuit is detected in front LH wheel sensor circuit.

POSSIBLE CAUSE

NOTE:

Confirm if DTC is PAST or CRNT. If DTC is CRNT, proceed with Diagnosis Procedure. If DTC is PAST, clear DTC. Do not replace the ABS actuator and electric unit (control unit) for a PAST DTC.

PAST DTC	CRNT DTC
<ul style="list-style-type: none">• Harness or connector• ABS actuator and electric unit (control unit) power supply system• Fuse• Fusible link• Battery	<ul style="list-style-type: none">• Harness or connector• Wheel sensor• ABS actuator and electric unit (control unit)• ABS actuator and electric unit (control unit) power supply system• Fuse• Fusible link• Battery• Vehicle was not driven after previous repair

DTC CONFIRMATION PROCEDURE

1. PRECONDITIONING

If "DTC CONFIRMATION PROCEDURE" has been previously conducted, always turn the ignition switch OFF and wait at least 10 seconds before conducting the next test.

>> GO TO 2.

2. CHECK DTC DETECTION

CONSULT

1. Start the engine.
2. Drive the vehicle at approx. 50 km/h (31 MPH) or more for approx. 2 minutes.
3. Stop the vehicle.
4. Turn the ignition switch OFF.

NOTE:

Wait at least 10 seconds after turning ignition switch OFF.

5. Start the engine.

NOTE:

Wait at least 10 seconds after start the engine.

6. Repeat step 4 to 5 two or more times.
7. Select "Self Diagnostic Result" mode of "ABS".

Is DTC "C1101", "C1102", "C1103" or "C1104" detected?

YES-1 >> "C1101", "C1102", "C1103" or "C1104" is displayed by "CRNT": Proceed to [BRC-264. "Diagnosis Procedure"](#).

C1101, C1102, C1103, C1104 WHEEL SENSOR

< DTC/CIRCUIT DIAGNOSIS >

[WITHOUT ICC]

YES-2 >> "C1101", "C1102", "C1103" and "C1104" are displayed by "PAST": Inspection End. (Erase the memory of "Self Diagnostic Result" mode of "ABS".)

NO-1 >> To check malfunction symptom before repair: Refer to [GI-42. "Intermittent Incident"](#).

NO-2 >> Confirmation after repair: Inspection End.

Diagnosis Procedure

INFOID:000000013444972

CAUTION:

Never check between wheel sensor harness connector terminals.

1. CHECK WHEEL SENSOR

1. Turn the ignition switch OFF.
2. Check the wheel sensor for damage.

Is the inspection result normal?

YES >> GO TO 3.

NO >> GO TO 2.

2. REPLACE WHEEL SENSOR (1)

CONSULT

1. Replace the wheel sensor.
 - Front: Refer to [BRC-167. "FRONT WHEEL SENSOR : Removal and Installation"](#).
 - Rear: Refer to [BRC-169. "REAR WHEEL SENSOR : Removal and Installation"](#).
2. Erase "Self Diagnostic Result" mode of "ABS".
3. Turn the ignition switch OFF → ON → OFF.

NOTE:

Wait at least 10 seconds after turning ignition switch OFF or ON.

4. Start the engine.
5. Drive the vehicle at approx. 50 km/h (31 MPH) or more for approx. 2 minutes.

NOTE:

Vehicle must be driven after repair or replacement to erase the previous DTCs.

6. Stop the vehicle.
7. Turn the ignition switch OFF.

NOTE:

Wait at least 10 seconds after turning ignition switch OFF.

8. Start the engine.

NOTE:

Wait at least 10 seconds after start the engine.

9. Repeat step 7 to 8 two or more times.
10. Select "Self Diagnostic Result" mode of "ABS".

Is DTC "C1101", "C1102", "C1103" or "C1104" detected?

YES >> GO TO 3.

NO >> Inspection End.

3. CHECK CONNECTOR

1. Turn the ignition switch OFF.
2. Check the ABS actuator and electric unit (control unit) harness connector for disconnection or looseness.
3. Check the wheel sensor harness connector for disconnection or looseness.

Is the inspection result normal?

YES >> GO TO 5.

NO >> Repair / replace harness or connector, securely lock the connector, and GO TO 4.

4. PERFORM SELF DIAGNOSTIC RESULT (1)

CONSULT

1. Erase "Self Diagnostic Result" mode of "ABS".
2. Turn the ignition switch OFF → ON → OFF.

NOTE:

Wait at least 10 seconds after turning ignition switch OFF or ON.

3. Start the engine.
4. Drive the vehicle at approx. 50 km/h (31 MPH) or more for approx. 2 minutes.

NOTE:

C1101, C1102, C1103, C1104 WHEEL SENSOR

[WITHOUT ICC]

< DTC/CIRCUIT DIAGNOSIS >

Vehicle must be driven after repair or replacement to erase the previous DTCs.

5. Stop the vehicle.
6. Turn the ignition switch OFF.

NOTE:

Wait at least 10 seconds after turning ignition switch OFF.

7. Start the engine.

NOTE:

Wait at least 10 seconds after start the engine.

8. Repeat step 6 to 7 two or more times.
9. Select "Self Diagnostic Result" mode of "ABS".

Is DTC "C1101", "C1102", "C1103" or "C1104" detected?

YES >> GO TO 5.

NO >> Inspection End.

5. CHECK ABS ACTUATOR AND ELECTRIC UNIT (CONTROL UNIT) POWER SUPPLY AND GROUND CIRCUIT

Check the ABS actuator and electric unit (control unit) power supply and ground circuit. Refer to [BRC-69, "Diagnosis Procedure"](#).

Is the inspection result normal?

YES >> GO TO 6.

NO >> Repair / replace harness, connector, fuse, or fusible link.

6. CHECK TERMINAL

1. Turn the ignition switch OFF.
2. Disconnect ABS actuator and electric unit (control unit) harness connector and then check the ABS actuator and electric unit (control unit) pin terminals for damage or loose connection with harness connector.
3. Disconnect wheel sensor harness connector and check each wheel sensor pin terminals for damage or loose connection with harness connector.

Is the inspection result normal?

YES >> GO TO 8.

NO >> Repair / replace harness, connector, or terminal, and GO TO 7.

7. PERFORM SELF DIAGNOSTIC RESULT (2)

Ⓟ CONSULT

1. Connect ABS actuator and electric unit (control unit) harness connector.
2. Connect wheel sensor harness connector.
3. Erase "Self Diagnostic Result" mode of "ABS".
4. Turn the ignition switch OFF → ON → OFF.

NOTE:

Wait at least 10 seconds after turning ignition switch OFF or ON.

5. Start the engine.
6. Drive the vehicle at approx. 50 km/h (31 MPH) or more for approx. 2 minutes.

NOTE:

Vehicle must be driven after repair or replacement to erase the previous DTCs.

7. Stop the vehicle.
8. Turn the ignition switch OFF.

NOTE:

Wait at least 10 seconds after turning ignition switch OFF.

9. Start the engine.

NOTE:

Wait at least 10 seconds after start the engine.

10. Repeat step 8 to 9 two or more times.
11. Select "Self Diagnostic Result" mode of "ABS".

Is DTC "C1101", "C1102", "C1103" or "C1104" detected?

YES >> GO TO 8.

NO >> Inspection End.

8. CHECK WHEEL SENSOR HARNESS

1. Turn the ignition switch OFF.

C1101, C1102, C1103, C1104 WHEEL SENSOR

[WITHOUT ICC]

< DTC/CIRCUIT DIAGNOSIS >

2. Disconnect ABS actuator and electric unit (control unit) harness connector.
 3. Disconnect wheel sensor harness connector.
 4. Check the continuity between ABS actuator and electric unit (control unit) harness connector and wheel sensor harness connector. (Check the continuity while turning steering wheel left and right, or while moving center harness in wheel housing.)
- Measurement connector and terminal for power supply circuit

ABS actuator and electric unit (control unit)		Wheel sensor		Continuity
Connector	Terminal	Connector	Terminal	
E125	19	E18 (Front LH wheel)	1	Yes
	16	E43 (Front RH wheel)		
	31	C10 (Rear LH wheel)		
	17	C11 (Rear RH wheel)		

- Measurement connector and terminal for signal circuit

ABS actuator and electric unit (control unit)		Wheel sensor		Continuity
Connector	Terminal	Connector	Terminal	
E125	8	E18 (Front LH wheel)	2	Yes
	4	E43 (Front RH wheel)		
	18	C10 (Rear LH wheel)		
	29	C11 (Rear RH wheel)		

Is the inspection result normal?

YES >> GO TO 10.

NO >> Repair / replace harness or connector, and GO TO 9.

9. PERFORM SELF DIAGNOSTIC RESULT (3)

CONSULT

1. Connect ABS actuator and electric unit (control unit) harness connector.
2. Connect wheel sensor harness connector.
3. Erase "Self Diagnostic Result" mode of "ABS".
4. Turn the ignition switch OFF → ON → OFF.

NOTE:
Wait at least 10 seconds after turning ignition switch OFF or ON.
5. Start the engine.
6. Drive the vehicle at approx. 50 km/h (31 MPH) or more for approx. 2 minutes.

NOTE:
Vehicle must be driven after repair or replacement to erase the previous DTCs.
7. Stop the vehicle.
8. Turn the ignition switch OFF.

NOTE:
Wait at least 10 seconds after turning ignition switch OFF.
9. Start the engine.

NOTE:
Wait at least 10 seconds after start the engine.
10. Repeat step 8 to 9 two or more times.
11. Select "Self Diagnostic Result" mode of "ABS".

Is DTC "C1101", "C1102", "C1103" or "C1104" detected?

YES >> GO TO 10.

NO >> Inspection End.

10. REPLACE WHEEL SENSOR

CONSULT

1. Replace the wheel sensor.
 - Front: Refer to [BRC-167, "FRONT WHEEL SENSOR : Removal and Installation"](#).
 - Rear: Refer to [BRC-169, "REAR WHEEL SENSOR : Removal and Installation"](#).

C1101, C1102, C1103, C1104 WHEEL SENSOR

[WITHOUT ICC]

< DTC/CIRCUIT DIAGNOSIS >

2. Erase "Self Diagnostic Result" mode of "ABS".
3. Turn the ignition switch OFF → ON → OFF.
NOTE:
Wait at least 10 seconds after turning ignition switch OFF or ON.
4. Start the engine.
5. Drive the vehicle at approx. 50 km/h (31 MPH) or more for approx. 2 minutes.
NOTE:
Vehicle must be driven after repair or replacement to erase the previous DTCs.
6. Stop the vehicle.
7. Turn the ignition switch OFF.
NOTE:
Wait at least 10 seconds after turning ignition switch OFF.
8. Start the engine.
NOTE:
Wait at least 10 seconds after start the engine.
9. Repeat step 7 to 8 two or more times.
10. Select "Self Diagnostic Result" mode of "ABS".

Is DTC "C1101", "C1102", "C1103" or "C1104" detected?

- YES >> Replace the ABS actuator and electric unit (control unit). Refer to [BRC-172. "Removal and Installation"](#).
- NO >> Inspection End.

C1105, C1106, C1107, C1108 WHEEL SENSOR

< DTC/CIRCUIT DIAGNOSIS >

[WITHOUT ICC]

C1105, C1106, C1107, C1108 WHEEL SENSOR

DTC Description

INFOID:000000013444973

DTC DETECTION LOGIC

DTC	Display Item (Trouble diagnosis content)	Malfunction detected condition
C1105	RR RH SENSOR-2 (Rear RH wheel sensor-2)	<ul style="list-style-type: none"> When power supply voltage of rear RH wheel sensor is low. When distance between rear RH wheel sensor and rear RH wheel sensor rotor is large. When installation of rear RH wheel sensor or rear RH wheel sensor rotor is not normal.
C1106	RR LH SENSOR-2 (Rear LH wheel sensor-2)	<ul style="list-style-type: none"> When power supply voltage of rear LH wheel sensor is low. When distance between rear LH wheel sensor and rear LH wheel sensor rotor is large. When installation of rear LH wheel sensor or rear LH wheel sensor rotor is not normal.
C1107	FR RH SENSOR-2 (Front RH wheel sensor-2)	<ul style="list-style-type: none"> When power supply voltage of front RH wheel sensor is low. When distance between front RH wheel sensor and front RH wheel sensor rotor is large. When installation of front RH wheel sensor or front RH wheel sensor rotor is not normal.
C1108	FR LH SENSOR-2 (Front LH wheel sensor-2)	<ul style="list-style-type: none"> When power supply voltage of front LH wheel sensor is low. When distance between front LH wheel sensor and front LH wheel sensor rotor is large. When installation of front LH wheel sensor or front LH wheel sensor rotor is not normal.

POSSIBLE CAUSE

NOTE:

Confirm if DTC is PAST or CRNT. If DTC is CRNT, proceed with Diagnosis Procedure. If DTC is PAST, clear DTC. Do not replace the ABS actuator and electric unit (control unit) for a PAST DTC.

PAST DTC	CRNT DTC
<ul style="list-style-type: none"> Harness or connector Wheel sensor Sensor rotor Tire size ABS actuator and electric unit (control unit) power supply system Fuse Fusible link Battery 	<ul style="list-style-type: none"> Harness or connector Wheel sensor Sensor rotor ABS actuator and electric unit (control unit) Tire size ABS actuator and electric unit (control unit) power supply system Fuse Fusible link Battery Vehicle was not driven after previous repair

DTC CONFIRMATION PROCEDURE

1. PRECONDITIONING

If "DTC CONFIRMATION PROCEDURE" has been previously conducted, always turn the ignition switch OFF and wait at least 10 seconds before conducting the next test.

>> GO TO 2.

2. CHECK DTC DETECTION

CONSULT

- Start the engine.
- Drive the vehicle at approx. 50 km/h (31 MPH) or more for approx. 2 minutes.
- Stop the vehicle.
- Turn the ignition switch OFF.

NOTE:

Wait at least 10 seconds after turning ignition switch OFF.

- Start the engine.

NOTE:

Wait at least 10 seconds after start the engine.

- Repeat step 4 to 5 two or more times.
- Select "Self Diagnostic Result" mode of "ABS".

C1105, C1106, C1107, C1108 WHEEL SENSOR

[WITHOUT ICC]

< DTC/CIRCUIT DIAGNOSIS >

Is DTC "C1105", "C1106", "C1107" or "C1108" detected?

YES-1 >> "C1105", "C1106", "C1107" or "C1108" is displayed by "CRNT": Proceed to [BRC-74, "Diagnosis Procedure"](#).

YES-2 >> "C1105", "C1106", "C1107" and "C1108" are displayed by "PAST": Inspection End. (Erase the memory of "Self Diagnostic Result" mode of "ABS".)

NO-1 >> To check malfunction symptom before repair: Refer to [GI-42, "Intermittent Incident"](#).

NO-2 >> Confirmation after repair: Inspection End.

Diagnosis Procedure

INFOID:000000013444974

CAUTION:

Never check between wheel sensor harness connector terminals.

1. CHECK WHEEL HUB ASSEMBLY

Check that there is no excessive looseness in wheel hub assembly.

- Front: Refer to [FAX-6, "On-vehicle Service"](#).
- Rear: Refer to [RAX-6, "On-vehicle Service"](#).

Is the inspection result normal?

YES >> GO TO 2.

NO >> Repair or replace the wheel hub assembly, and GO TO 2.

- Front: Refer to [FAX-8, "Removal and Installation"](#).
- Rear: Refer to [RAX-8, "Removal and Installation"](#).

2. CHECK ABS ACTUATOR AND ELECTRIC UNIT (CONTROL UNIT) POWER SUPPLY AND GROUND CIRCUIT

Check the ABS actuator and electric unit (control unit) power supply and ground circuit. Refer to [BRC-80, "Diagnosis Procedure"](#).

Is the inspection result normal?

YES >> GO TO 3.

NO >> Repair / replace harness, connector, fuse, or fusible link.

3. CHECK TIRE

1. Turn the ignition switch OFF.
2. Check the tire air pressure, wear and size. Refer to [GI-37, "Wheels & Tires"](#).

Is the inspection result normal?

YES >> GO TO 6.

NO >> Adjust air pressure or replace tire, and GO TO 4.

4. CHECK DATA MONITOR (1)

CONSULT

1. Erase "Self Diagnostic Result" mode of "ABS".

2. Turn the ignition switch OFF → ON → OFF.

NOTE:

Wait at least 10 seconds after turning ignition switch OFF or ON.

3. Start the engine.

4. Select "ABS" and "Data Monitor", check "FR LH SENSOR", "FR RH SENSOR", "RR LH SENSOR" and "RR RH SENSOR".

NOTE:

Set the "Data Monitor" recording speed to "10 msec".

5. Read a value (wheel speed) of both normal wheel sensors and error-detecting wheel sensor.

NOTE:

Vehicle must be driven after repair or replacement to erase the previous DTCs.

Note the difference at 50 km/h (31 MPH) between the wheel speed detected by the error detecting wheel sensor and the maximum/minimum wheel speed detected by the normal wheel sensors. Is the difference within 5%, respectively?

YES >> GO TO 5.

NO >> GO TO 6.

5. PERFORM SELF DIAGNOSTIC RESULT (1)

C1105, C1106, C1107, C1108 WHEEL SENSOR

< DTC/CIRCUIT DIAGNOSIS >

[WITHOUT ICC]

CONSULT

1. Stop the vehicle.
2. Turn the ignition switch OFF.

NOTE:

Wait at least 10 seconds after turning ignition switch OFF.

3. Start the engine.

NOTE:

Wait at least 10 seconds after start the engine.

4. Repeat step 2 to 3 two or more times.
5. Select "Self Diagnostic Result" mode of "ABS".

Is DTC "C1105", "C1106", "C1107" or "C1108" detected?

YES >> GO TO 6.

NO >> Inspection End.

6. CHECK WHEEL SENSOR

1. Turn the ignition switch OFF.
2. Check the wheel sensor for damage.
3. Remove dust and foreign matter adhered to the sensor rotor with a vacuum dust collector through the wheel sensor mounting hole.

CAUTION:

Install wheel sensor with no backlash and float, and tighten the mounting bolt to the specified torque.

- Front: Refer to [BRC-167, "FRONT WHEEL SENSOR : Removal and Installation"](#).
- Rear: Refer to [BRC-169, "REAR WHEEL SENSOR : Removal and Installation"](#).

Is the inspection result normal?

YES >> GO TO 9.

NO >> GO TO 7.

7. REPLACE WHEEL SENSOR (1)

CONSULT

1. Replace the wheel sensor.
 - Front: Refer to [BRC-167, "FRONT WHEEL SENSOR : Removal and Installation"](#).
 - Rear: Refer to [BRC-169, "REAR WHEEL SENSOR : Removal and Installation"](#).
2. Erase "Self Diagnostic Result" mode of "ABS".
3. Turn the ignition switch OFF → ON → OFF.

NOTE:

Wait at least 10 seconds after turning ignition switch OFF or ON.

4. Start the engine.
5. Select "ABS" and "Data Monitor", check "FR LH SENSOR", "FR RH SENSOR", "RR LH SENSOR" and "RR RH SENSOR".

NOTE:

Set the "Data Monitor" recording speed to "10 msec".

6. Read a value (wheel speed) of both normal wheel sensors and error-detecting wheel sensor.

NOTE:

Vehicle must be driven after repair or replacement to erase the previous DTCs.

Note the difference at 50 km/h (31 MPH) between the wheel speed detected by the error detecting wheel sensor and the maximum/minimum wheel speed detected by the normal wheel sensors. Is the difference within 5%, respectively?

YES >> GO TO 8.

NO >> GO TO 20.

8. PERFORM SELF DIAGNOSTIC RESULT (2)

CONSULT

1. Stop the vehicle.
2. Turn the ignition switch OFF.

NOTE:

Wait at least 10 seconds after turning ignition switch OFF.

3. Start the engine.

NOTE:

C1105, C1106, C1107, C1108 WHEEL SENSOR

< DTC/CIRCUIT DIAGNOSIS >

[WITHOUT ICC]

Wait at least 10 seconds after start the engine.

- Repeat step 2 to 3 two or more times.
- Select "Self Diagnostic Result" mode of "ABS".

Is DTC "C1105", "C1106", "C1107" or "C1108" detected?

- YES >> GO TO 20.
NO >> Inspection End.

9. CHECK CONNECTOR

- Turn the ignition switch OFF.
- Check the ABS actuator and electric unit (control unit) harness connector for disconnection or looseness.
- Check the wheel sensor harness connector for disconnection or looseness.

Is the inspection result normal?

- YES >> GO TO 12.
NO >> Repair / replace harness or connector, securely lock the connector, and GO TO 10.

10. CHECK DATA MONITOR (2)

CONSULT

- Erase "Self Diagnostic Result" mode of "ABS".
- Turn the ignition switch OFF → ON → OFF.
NOTE:
Wait at least 10 seconds after turning ignition switch OFF or ON.
- Start the engine.
- Select "ABS" and "Data Monitor", check "FR LH SENSOR", "FR RH SENSOR", "RR LH SENSOR" and "RR RH SENSOR".

NOTE:
Set the "Data Monitor" recording speed to "10 msec".

- Read a value (wheel speed) of both normal wheel sensors and error-detecting wheel sensor.

NOTE:
Vehicle must be driven after repair or replacement to erase the previous DTCs.

Note the difference at 50 km/h (31 MPH) between the wheel speed detected by the error detecting wheel sensor and the maximum/minimum wheel speed detected by the normal wheel sensors. Is the difference within 5%, respectively?

- YES >> GO TO 11.
NO >> GO TO 12.

11. PERFORM SELF DIAGNOSTIC RESULT (3)

CONSULT

- Stop the vehicle.
- Turn the ignition switch OFF.
NOTE:
Wait at least 10 seconds after turning ignition switch OFF.
- Start the engine.

NOTE:
Wait at least 10 seconds after start the engine.

- Repeat step 2 to 3 two or more times.
- Select "Self Diagnostic Result" mode of "ABS".

Is DTC "C1105", "C1106", "C1107" or "C1108" detected?

- YES >> GO TO 12.
NO >> Inspection End.

12. CHECK TERMINAL

- Turn the ignition switch OFF.
- Disconnect ABS actuator and electric unit (control unit) harness connector and then check the ABS actuator and electric unit (control unit) pin terminals for damage or loose connection with harness connector.
- Disconnect wheel sensor harness connector and check each wheel sensor pin terminals for damage or loose connection with harness connector.

Is the inspection result normal?

- YES >> GO TO 15.

C1105, C1106, C1107, C1108 WHEEL SENSOR

< DTC/CIRCUIT DIAGNOSIS >

[WITHOUT ICC]

NO >> Repair / replace harness, connector, or terminal, and GO TO 13.

13. CHECK DATA MONITOR (3)

CONSULT

1. Connect ABS actuator and electric unit (control unit) harness connector.
2. Connect wheel sensor harness connector.
3. Erase "Self Diagnostic Result" mode of "ABS".
4. Turn the ignition switch OFF → ON → OFF.

NOTE:

Wait at least 10 seconds after turning ignition switch OFF or ON.

5. Start the engine.
6. Select "ABS" and "Data Monitor", check "FR LH SENSOR", "FR RH SENSOR", "RR LH SENSOR" and "RR RH SENSOR".

NOTE:

Set the "Data Monitor" recording speed to "10 msec".

7. Read a value (wheel speed) of both normal wheel sensors and error-detecting wheel sensor.

NOTE:

Vehicle must be driven after repair or replacement to erase the previous DTCs.

Note the difference at 50 km/h (31 MPH) between the wheel speed detected by the error detecting wheel sensor and the maximum/minimum wheel speed detected by the normal wheel sensors. Is the difference within 5%, respectively?

YES >> GO TO 14.

NO >> GO TO 15.

14. PERFORM SELF DIAGNOSTIC RESULT (4)

CONSULT

1. Stop the vehicle.
 2. Turn the ignition switch OFF.
- NOTE:**
Wait at least 10 seconds after turning ignition switch OFF.

3. Start the engine.

NOTE:

Wait at least 10 seconds after start the engine.

4. Repeat step 2 to 3 two or more times.
5. Select "Self Diagnostic Result" mode of "ABS".

Is DTC "C1105", "C1106", "C1107" or "C1108" detected?

YES >> GO TO 15.

NO >> Inspection End.

15. CHECK WHEEL SENSOR HARNESS

1. Turn the ignition switch OFF.
2. Disconnect ABS actuator and electric unit (control unit) harness connector.
3. Disconnect wheel sensor harness connector.
4. Check the continuity between ABS actuator and electric unit (control unit) harness connector and the ground.

ABS actuator and electric unit (control unit)		—	Continuity
Connector	Terminal		
E125	19, 8	Ground	No
	16, 4		
	31, 18		
	17, 29		

Is the inspection result normal?

YES >> GO TO 16.

NO >> Repair / replace harness or connector, and GO TO 16.

16. CHECK DATA MONITOR (4)

C1105, C1106, C1107, C1108 WHEEL SENSOR

[WITHOUT ICC]

< DTC/CIRCUIT DIAGNOSIS >

CONSULT

1. Connect ABS actuator and electric unit (control unit) harness connector.
2. Connect wheel sensor harness connector.
3. Erase "Self Diagnostic Result" mode of "ABS".
4. Turn the ignition switch OFF → ON → OFF.

NOTE:

Wait at least 10 seconds after turning ignition switch OFF or ON.

5. Start the engine.
6. Select "ABS" and "Data Monitor", check "FR LH SENSOR", "FR RH SENSOR", "RR LH SENSOR" and "RR RH SENSOR".

NOTE:

Set the "Data Monitor" recording speed to "10 msec".

7. Read a value (wheel speed) of both normal wheel sensors and error-detecting wheel sensor.

NOTE:

Vehicle must be driven after repair or replacement to erase the previous DTCs.

Note the difference at 50 km/h (31 MPH) between the wheel speed detected by the error detecting wheel sensor and the maximum/minimum wheel speed detected by the normal wheel sensors. Is the difference within 5%, respectively?

YES >> GO TO 17.

NO >> GO TO 18.

17.PERFORM SELF DIAGNOSTIC RESULT (5)

CONSULT

1. Stop the vehicle.
2. Turn the ignition switch OFF.

NOTE:

Wait at least 10 seconds after turning ignition switch OFF.

3. Start the engine.

NOTE:

Wait at least 10 seconds after start the engine.

4. Repeat step 2 to 3 two or more times.
5. Select "Self Diagnostic Result" mode of "ABS".

Is DTC "C1105", "C1106", "C1107" or "C1108" detected?

YES >> GO TO 18.

NO >> Inspection End.

18.REPLACE WHEEL SENSOR (2)

CONSULT

1. Replace the wheel sensor.
 - Front: Refer to [BRC-167. "FRONT WHEEL SENSOR : Removal and Installation"](#).
 - Rear: Refer to [BRC-169. "REAR WHEEL SENSOR : Removal and Installation"](#).
2. Erase "Self Diagnostic Result" mode of "ABS".
3. Turn the ignition switch OFF → ON → OFF.

NOTE:

Wait at least 10 seconds after turning ignition switch OFF or ON.

4. Start the engine.
5. Select "ABS" and "Data Monitor", check "FR LH SENSOR", "FR RH SENSOR", "RR LH SENSOR" and "RR RH SENSOR".

NOTE:

Set the "Data Monitor" recording speed to "10 msec".

6. Read a value (wheel speed) of both normal wheel sensors and error-detecting wheel sensor.

NOTE:

Vehicle must be driven after repair or replacement to erase the previous DTCs.

Note the difference at 50 km/h (31 MPH) between the wheel speed detected by the error detecting wheel sensor and the maximum/minimum wheel speed detected by the normal wheel sensors. Is the difference within 5%, respectively?

YES >> GO TO 19.

NO >> GO TO 20.

C1105, C1106, C1107, C1108 WHEEL SENSOR

< DTC/CIRCUIT DIAGNOSIS >

[WITHOUT ICC]

19. PERFORM SELF DIAGNOSTIC RESULT (6)

CONSULT

1. Stop the vehicle.
2. Turn the ignition switch OFF.
NOTE:
Wait at least 10 seconds after turning ignition switch OFF.
3. Start the engine.
NOTE:
Wait at least 10 seconds after start the engine.
4. Repeat step 2 to 3 two or more times.
5. Select "Self Diagnostic Result" mode of "ABS".

Is DTC "C1105", "C1106", "C1107" or "C1108" detected?

YES >> GO TO 20.

NO >> Inspection End.

20. REPLACE SENSOR ROTOR

CONSULT

1. Replace the sensor rotor.
 - Front: Refer to [BRC-171, "FRONT SENSOR ROTOR : Removal and Installation - Front Sensor Rotor"](#).
 - Rear: Refer to [BRC-171, "REAR SENSOR ROTOR : Removal and Installation - Rear Sensor Rotor"](#).
2. Erase "Self Diagnostic Result" mode of "ABS".
3. Turn the ignition switch OFF → ON → OFF.
NOTE:
Wait at least 10 seconds after turning ignition switch OFF or ON.
4. Start the engine.
5. Drive the vehicle at approx. 50 km/h (31 MPH) or more for approx. 2 minutes.
NOTE:
Vehicle must be driven after repair or replacement to erase the previous DTCs.
6. Stop the vehicle.
7. Turn the ignition switch OFF.
NOTE:
Wait at least 10 seconds after turning ignition switch OFF.
8. Start the engine.
NOTE:
Wait at least 10 seconds after start the engine.
9. Repeat step 7 to 8 two or more times.
10. Select "Self Diagnostic Result" mode of "ABS".

Is DTC "C1105", "C1106", "C1107" or "C1108" detected?

YES >> Replace the ABS actuator and electric unit (control unit). Refer to [BRC-172, "Removal and Installation"](#).

NO >> Inspection End.

A
B
C
D
E
BRC
G
H
I
J
K
L
M
N
O
P

C1109 POWER AND GROUND SYSTEM

< DTC/CIRCUIT DIAGNOSIS >

[WITHOUT ICC]

C1109 POWER AND GROUND SYSTEM

DTC Description

INFOID:000000013444975

DTC DETECTION LOGIC

DTC	Display Item (Trouble diagnosis content)	Malfunction detected condition
C1109	BATTERY VOLTAGE [ABNORMAL] (Battery voltage [abnormal])	When ignition power supply voltage is in following state. <ul style="list-style-type: none">Ignition power supply voltage: $10\text{ V} \geq$ ignition power supply voltage.Ignition power supply voltage: $16\text{ V} \leq$ ignition power supply voltage.

POSSIBLE CAUSE

NOTE:

Confirm if DTC is PAST or CRNT. If DTC is CRNT, proceed with Diagnosis Procedure. If DTC is PAST, clear DTC. Do not replace the ABS actuator and electric unit (control unit) for a PAST DTC.

PAST DTC	CRNT DTC
<ul style="list-style-type: none">Harness or connectorABS actuator and electric unit (control unit) power supply systemFuseFusible linkBatteryCharge system	<ul style="list-style-type: none">Harness or connectorABS actuator and electric unit (control unit)IPDM E/RABS actuator and electric unit (control unit) power supply systemFuseFusible linkBatteryCharge system

DTC CONFIRMATION PROCEDURE

1. PRECONDITIONING

If "DTC CONFIRMATION PROCEDURE" has been previously conducted, always turn the ignition switch OFF and wait at least 10 seconds before conducting the next test.

>> GO TO 2.

2. CHECK DTC DETECTION

CONSULT

- Turn the ignition switch OFF.
NOTE:
Wait at least 10 seconds after turning ignition switch OFF.
- Start the engine.
NOTE:
Wait at least 10 seconds after start the engine.
- Repeat step 1 to 2 two or more times.
- Select "Self Diagnostic Result" for "ABS".

Is DTC "C1109" detected?

- YES-1 >> "CRNT" is displayed: Proceed to [BRC-80, "Diagnosis Procedure"](#).
YES-2 >> "PAST" is displayed: Inspection End. (Erase the memory of "Self Diagnostic Result" for "ABS".)
NO-1 >> To check malfunction symptom before repair: Refer to [GI-42, "Intermittent Incident"](#).
NO-2 >> Confirmation after repair: Inspection End.

Diagnosis Procedure

INFOID:000000013444976

1. CHECK CONNECTOR

- Turn the ignition switch OFF.
- Check the ABS actuator and electric unit (control unit) harness connector for disconnection or looseness.

Is the inspection result normal?

YES >> GO TO 3.

C1109 POWER AND GROUND SYSTEM

< DTC/CIRCUIT DIAGNOSIS >

[WITHOUT ICC]

NO >> Repair / replace harness or connector, securely lock the connector, and GO TO 2.

2.PERFORM SELF DIAGNOSTIC RESULT

1. Turn the ignition switch OFF.

NOTE:

Wait at least 10 seconds after turning ignition switch OFF.

2. Start the engine.

NOTE:

Wait at least 10 seconds after start the engine.

3. Repeat step 1 to 2 two or more times.

4. Select "Self Diagnostic Result" mode of "ABS".

Is DTC "C1109" detected?

YES >> GO TO 3.

NO >> Inspection End.

3.CHECK ABS ACTUATOR AND ELECTRIC UNIT (CONTROL UNIT) POWER SUPPLY AND GROUND CIRCUIT

Check the ABS actuator and electric unit (control unit) power supply and ground circuit. Refer to [BRC-80. "Diagnosis Procedure"](#).

Is the inspection result normal?

YES >> GO TO 4.

NO >> Repair / replace harness, connector, fuse, or fusible link.

4.CHECK TERMINAL

1. Check the ABS actuator and electric unit (control unit) pin terminals for damage or loose connection with harness connector.

2. Check the IPDM E/R pin terminals for damage or loose connection with harness connector.

Is the inspection result normal?

YES >> Replace the ABS actuator and electric unit (control unit). Refer to [BRC-172. "Removal and Installation"](#).

NO >> Repair / replace harness, connector, or terminal.

A
B
C
D
E
G
H
I
J
K
L
M
N
O
P

BRC

C1110, C1153 ABS ACTUATOR AND ELECTRIC UNIT (CONTROL UNIT)

< DTC/CIRCUIT DIAGNOSIS >

[WITHOUT ICC]

C1110, C1153 ABS ACTUATOR AND ELECTRIC UNIT (CONTROL UNIT)

DTC Description

INFOID:000000013444977

DTC DETECTION LOGIC

DTC	Display Item (Trouble diagnosis content)	Malfunction detected condition
C1110	CONTROLLER FAILURE (Controller failure)	When there is an internal malfunction in the ABS actuator and electric unit (control unit).
C1153	EMERGENCY BRAKE (Emergency brake)	When ABS actuator and electric unit (control unit) is malfunctioning (pressure increase is too much or too little).

POSSIBLE CAUSE

NOTE:

Confirm if DTC is PAST or CRNT. If DTC is CRNT, proceed with Diagnosis Procedure. If DTC is PAST, clear the DTC. Do not replace the ABS actuator and electric unit (control unit) for a PAST DTC.

DTC	PAST DTC	CRNT DTC
C1110	<ul style="list-style-type: none">The vehicle travels near high-voltage electrical power lines.Motor that is built-in the ABS actuator and electric unit (control unit) operates temporarily without a break.Harness or connectorABS actuator and electric unit (control unit) power supply systemFuseFusible linkBattery	<ul style="list-style-type: none">ABS actuator and electric unit (control unit)Harness or connectorABS actuator and electric unit (control unit) power supply systemFuseFusible linkBattery
C1153	<ul style="list-style-type: none">The vehicle travels near high-voltage electrical power lines.ABS operates for a long time (e.g., travel under a tire hydroplaning condition).	ABS actuator and electric unit (control unit)

DTC CONFIRMATION PROCEDURE

1. PRECONDITIONING

If "DTC CONFIRMATION PROCEDURE" has been previously conducted, always turn the ignition switch OFF and wait at least 10 seconds before conducting the next test.

>> GO TO 2.

2. CHECK DTC DETECTION

CONSULT

1. Turn the ignition switch OFF.

NOTE:

Wait at least 10 seconds after turning ignition switch OFF.

2. Start the engine.

NOTE:

Wait at least 10 seconds after starting the engine.

3. Select "Self Diagnostic Result" mode of "ABS".

Is DTC "C1110" or "C1153" detected?

YES-1 >> "C1110" or "C1153" is displayed as "CRNT": Proceed to [BRC-83, "Diagnosis Procedure"](#).

YES-2 >> "C1110" or "C1153" is displayed as "PAST": Inspection End. (Erase "Self Diagnostic Result" mode of "ABS".)

NO-1 >> To check malfunction symptom before repair: Refer to [GI-42, "Intermittent Incident"](#).

NO-2 >> Confirmation after repair: Inspection End.

C1110, C1153 ABS ACTUATOR AND ELECTRIC UNIT (CONTROL UNIT)

< DTC/CIRCUIT DIAGNOSIS >

[WITHOUT ICC]

Diagnosis Procedure

INFOID:000000013444978

1. ADJUST THE NEUTRAL POSITION OF STEERING ANGLE SENSOR

ⓂCONSULT

Perform neutral position adjustment of steering angle sensor. Refer to [BRC-62, "Description"](#).

Is neutral position adjustment of steering angle sensor finished?

YES >> GO TO 2.

NO >> Check the steering angle sensor system. Refer to [BRC-62, "Description"](#).

2. CHECK ABS ACTUATOR AND ELECTRIC UNIT (CONTROL UNIT) POWER SUPPLY AND GROUND CIRCUIT

Check the ABS actuator and electric unit (control unit) power supply and ground circuits. Refer to [BRC-80, "Diagnosis Procedure"](#).

Is the inspection result normal?

YES >> GO TO 3.

NO >> Repair / replace harness, connector, fuse, or fusible link.

3. PERFORM SELF-DIAGNOSIS

ⓂCONSULT

Select "Self Diagnostic Result" mode of "ABS".

NOTE:

Replace the ABS actuator and electric unit (control unit) even if other DTCs are displayed along with "C1110" or "C1153" in "Self Diagnostic Result" mode of "ABS".

Is DTC "C1110" or "C1153" detected?

YES >> Replace the ABS actuator and electric unit (control unit). Refer to [BRC-172, "Removal and Installation"](#).

NO >> Inspection End. (Although motor that is built-in the ABS actuator and electric unit (control unit) operates temporarily without a break, this is not a malfunction. Erase "Self Diagnostic Result" mode of "ABS".)

A
B
C
D
E
BRC
G
H
I
J
K
L
M
N
O
P

C1111 ABS MOTOR, MOTOR RELAY SYSTEM

< DTC/CIRCUIT DIAGNOSIS >

[WITHOUT ICC]

C1111 ABS MOTOR, MOTOR RELAY SYSTEM

DTC Description

INFOID:000000013444979

DTC DETECTION LOGIC

DTC	Display Item (Trouble diagnosis content)	Malfunction detected condition
C1111	PUMP MOTOR (Pump motor and motor relay)	When a malfunction is detected in motor or motor relay.

POSSIBLE CAUSE

NOTE:

Confirm if DTC is PAST or CRNT. If DTC is CRNT, proceed with Diagnosis Procedure. If DTC is PAST, clear DTC. Do not replace the ABS actuator and electric unit (control unit) for a PAST DTC.

PAST DTC	CRNT DTC
<ul style="list-style-type: none">• Harness or connector• ABS actuator and electric unit (control unit) power supply system• Fuse• Fusible link• Battery	<ul style="list-style-type: none">• Harness or connector• ABS actuator and electric unit (control unit)• ABS actuator and electric unit (control unit) power supply system• Fuse• Fusible link• Battery• Motor/accumulator assembly

DTC CONFIRMATION PROCEDURE

1. PRECONDITIONING

If "DTC CONFIRMATION PROCEDURE" has been previously conducted, always turn the ignition switch OFF and wait at least 10 seconds before conducting the next test.

>> GO TO 2.

2. CHECK DTC DETECTION

ⓅCONSULT

1. Turn the ignition switch OFF → ON, and wait 30 seconds.
2. Drive the vehicle at approx. 50 km/h (31 MPH) or more for approx. 2 minutes.
3. Stop the vehicle.
4. Turn the ignition switch OFF.

NOTE:

Wait at least 10 seconds after turning ignition switch OFF.

5. Start the engine.

NOTE:

Wait at least 10 seconds after start the engine.

6. Repeat step 4 to 5 two or more times.
7. Select "Self Diagnostic Result" mode of "ABS".

Is DTC "C1111" detected?

YES-1 >> "CRNT" is displayed: Proceed to [BRC-279, "Diagnosis Procedure"](#).

YES-2 >> "PAST" is displayed: Inspection End. (Erase the memory of "Self Diagnostic Result" mode of "ABS".)

NO-1 >> To check malfunction symptom before repair: Refer to [GI-42, "Intermittent Incident"](#).

NO-2 >> Confirmation after repair: Inspection End.

Diagnosis Procedure

INFOID:000000013444980

1. CHECK CONNECTOR

1. Turn the ignition switch OFF.
2. Check the ABS actuator and electric unit (control unit) harness connector for disconnection or looseness.

C1111 ABS MOTOR, MOTOR RELAY SYSTEM

[WITHOUT ICC]

< DTC/CIRCUIT DIAGNOSIS >

Is the inspection result normal?

YES >> GO TO 3.

NO >> Repair / replace harness or connector, securely lock the connector, and GO TO 2.

2.PERFORM SELF DIAGNOSTIC RESULT

ⓂCONSULT

1. Turn the ignition switch OFF → ON, and wait 30 seconds.

2. Drive the vehicle at approx. 50 km/h (31 MPH) or more for approx. 2 minutes.

NOTE:

Vehicle must be driven after repair or replacement to erase the previous DTCs.

3. Stop the vehicle.

4. Turn the ignition switch OFF.

NOTE:

Wait at least 10 seconds after turning ignition switch OFF.

5. Start the engine.

NOTE:

Wait at least 10 seconds after start the engine.

6. Repeat step 4 to 5 two or more times.

7. Select "Self Diagnostic Result" mode of "ABS".

Is DTC "C1111" detected?

YES >> GO TO 3.

NO >> Inspection End.

3.CHECK ABS ACTUATOR AND ELECTRIC UNIT (CONTROL UNIT) POWER SUPPLY AND GROUND CIRCUIT

Check the ABS actuator and electric unit (control unit) power supply and ground circuit. Refer to [BRC-80, "Diagnosis Procedure"](#).

Is the inspection result normal?

YES >> GO TO 5.

NO >> Repair / replace harness, connector, or fuse, and GO TO 4.

4.ERASE SELF DIAGNOSTIC RESULT (1)

ⓂCONSULT

1. Drive the vehicle at approx. 50 km/h (31 MPH) or more for approx. 2 minutes.

NOTE:

Vehicle must be driven after repair or replacement to erase the previous DTCs.

2. Stop the vehicle.

3. Erase "Self Diagnostic Result" mode of "ABS".

4. Turn the ignition switch OFF → ON → OFF.

NOTE:

Wait at least 10 seconds after turning ignition switch OFF or ON.

>> Inspection End.

5.CHECK TERMINAL

1. Turn the ignition switch OFF.

2. Check the ABS actuator and electric unit (control unit) pin terminals for damage or loose connection with harness connector.

Is the inspection result normal?

YES >> Replace the ABS actuator and electric unit (control unit). Refer to [BRC-172, "Removal and Installation"](#).

NO >> Repair / replace harness or connector, and GO TO 6.

6.ERASE SELF-DIAGNOSIS RESULT (2)

ⓂCONSULT

1. Drive the vehicle at approx. 50 km/h (31 MPH) or more for approx. 2 minutes.

NOTE:

Vehicle must be driven after repair or replacement to erase the previous DTCs.

C1111 ABS MOTOR, MOTOR RELAY SYSTEM

< DTC/CIRCUIT DIAGNOSIS >

[WITHOUT ICC]

2. Stop the vehicle.
3. Erase "Self Diagnostic Result" mode of "ABS".
4. Turn the ignition switch OFF → ON → OFF.

NOTE:

Wait at least 10 seconds after turning ignition switch OFF or ON.

>> Inspection End.

C1113, C1145, C1146 YAW RATE/SIDE/DECEL G SENSOR

< DTC/CIRCUIT DIAGNOSIS >

[WITHOUT ICC]

C1113, C1145, C1146 YAW RATE/SIDE/DECEL G SENSOR

DTC Description

INFOID:000000013444981

DTC DETECTION LOGIC

DTC	Display item (Trouble diagnosis content)	Malfunction detected condition
C1113	G-SENSOR (Decel G sensor circuit)	When a malfunction is detected in decel G signal.
C1145	YAW RATE SENSOR (Yaw rate sensor circuit)	<ul style="list-style-type: none"> When a malfunction is detected in yaw rate signal. When a signal line of yaw rate/side/decel G sensor is open or shorted. When power supply voltage of yaw rate/side/decel G sensor is in following state. <ul style="list-style-type: none"> - Yaw rate/side/decel G sensor power supply voltage: $4.8\text{ V} \geq \text{yaw rate/side/decel G sensor power supply voltage}$ - Yaw rate/side/decel G sensor power supply voltage: $5.2\text{ V} \leq \text{yaw rate/side/decel G sensor power supply voltage}$
C1146	SIDE G-SEN CIRCUIT (Side G sensor circuit)	When a malfunction is detected in side G signal.

POSSIBLE CAUSE

NOTE:

Confirm if DTC is PAST or CRNT. If DTC is CRNT, proceed with Diagnosis Procedure. If DTC is PAST, clear DTC. Do not replace the ABS actuator and electric unit (control unit) for a PAST DTC.

DTC	PAST DTC	CRNT DTC
C1113	<ul style="list-style-type: none"> Harness or connector ABS actuator and electric unit (control unit) power supply system Fuse Fusible link Battery Change in vehicle posture (e.g. different tire sizes on front and rear, overload) 	<ul style="list-style-type: none"> Harness or connector Yaw rate/side/decel G sensor ABS actuator and electric unit (control unit) ABS actuator and electric unit (control unit) power supply system Fuse Fusible link Battery Change in vehicle posture (e.g. different tire sizes on front and rear, overload)
C1145	<ul style="list-style-type: none"> Harness or connector ABS actuator and electric unit (control unit) power supply system Fuse Fusible link Battery 	<ul style="list-style-type: none"> Harness or connector Yaw rate/side/decel G sensor ABS actuator and electric unit (control unit) ABS actuator and electric unit (control unit) power supply system Fuse Fusible link Battery
C1146		

DTC CONFIRMATION PROCEDURE

1. PRECONDITIONING

If "DTC CONFIRMATION PROCEDURE" has been previously conducted, always turn the ignition switch OFF and wait at least 10 seconds before conducting the next test.

>> GO TO 2.

2. CHECK DTC DETECTION

CONSULT

1. Turn the ignition switch OFF.

NOTE:

Wait at least 10 seconds after turning ignition switch OFF.

2. Start the engine.

NOTE:

Wait at least 10 seconds after start the engine.

C1113, C1145, C1146 YAW RATE/SIDE/DECEL G SENSOR

< DTC/CIRCUIT DIAGNOSIS >

[WITHOUT ICC]

3. Repeat step 1 to 2 two or more times.
4. Select "Self Diagnostic" mode of "ABS".

Is DTC "C1113", "C1145" or "C1146" detected?

YES-1 >> "C1113", "C1145", or "C1146" is displayed by "CRNT": Proceed to [BRC-88, "Diagnosis Procedure"](#).

YES-2 >> "C1113", "C1145", and "C1146" are displayed by "PAST": Inspection End (Erase the memory of "Self Diagnostic" mode of "ABS".)

NO-1 >> To check malfunction symptom before repair: Refer to [GI-42, "Intermittent Incident"](#).

NO-2 >> Confirmation after repair: Inspection End.

Diagnosis Procedure

INFOID:000000013444982

1. CHECK ABS ACTUATOR AND ELECTRIC UNIT (CONTROL UNIT) POWER SUPPLY AND GROUND CIRCUIT

Check the ABS actuator and electric unit (control unit) power supply and ground circuit. Refer to [BRC-80, "Diagnosis Procedure"](#).

Is the inspection result normal?

YES >> GO TO 2.

NO >> Repair / replace harness, connector, fuse, or fusible link.

2. PERFORM SELF DIAGNOSTIC RESULT

ⓅCONSULT

1. Turn the ignition switch OFF.

NOTE:

Wait at least 10 seconds after turning ignition switch OFF.

2. Start the engine.

NOTE:

Wait at least 10 seconds after start the engine.

3. Repeat step 1 to 2 two or more times.
4. Select "Self Diagnostic Result" mode of "ABS".

Is DTC "C1113", "C1145" or "C1146" detected?

YES >> Replace the ABS actuator and electric unit (control unit). Refer to [BRC-172, "Removal and Installation"](#).

NO >> Inspection End.

C1115 WHEEL SENSOR

< DTC/CIRCUIT DIAGNOSIS >

[WITHOUT ICC]

C1115 WHEEL SENSOR

DTC Description

INFOID:000000013444983

DTC DETECTION LOGIC

DTC	Display Item (Trouble diagnosis content)	Malfunction detected condition
C1115	ABS SENSOR [ABNORMAL SIGNAL] (Wheel sensor [abnormal signal])	When difference in wheel speed between any wheel and others is detected the vehicle is driven, because of installation of other tires than specified.

POSSIBLE CAUSE

NOTE:

Confirm if DTC is PAST or CRNT. If DTC is CRNT, proceed with Diagnosis Procedure. If DTC is PAST, clear DTC. Do not replace the ABS actuator and electric unit (control unit) for a PAST DTC.

PAST DTC	CRNT DTC
<ul style="list-style-type: none"> • Harness or connector • Wheel sensor • Sensor rotor • ABS actuator and electric unit (control unit) power supply system • Fuse • Fusible link • Battery 	<ul style="list-style-type: none"> • Harness or connector • Wheel sensor • Sensor rotor • ABS actuator and electric unit (control unit) • ABS actuator and electric unit (control unit) power supply system • Fuse • Fusible link • Battery • Tire size

DTC CONFIRMATION PROCEDURE

1. PRECONDITIONING

If "DTC CONFIRMATION PROCEDURE" has been previously conducted, always turn the ignition switch OFF and wait at least 10 seconds before conducting the next test.

>> GO TO 2.

2. CHECK DTC DETECTION

CONSULT

1. Start the engine.
2. Drive the vehicle at approx. 50 km/h (19 MPH) or more for approx. 2 minutes.
3. Stop the vehicle.
4. Turn the ignition switch OFF.

NOTE:

Wait at least 10 seconds after turning ignition switch OFF.

5. Start the engine.

NOTE:

Wait at least 10 seconds after start the engine.

6. Repeat step 4 to 5 two or more times.
7. Select "Self Diagnostic Result" mode of "ABS".

Is DTC "C1115" detected?

YES-1 >> "CRNT" is displayed: Proceed to [BRC-89, "Diagnosis Procedure"](#).

YES-2 >> "PAST" is displayed: Inspection End. (Erase the memory of self-diagnosis results.)

NO-1 >> To check malfunction symptom before repair: Refer to [GI-42, "Intermittent Incident"](#).

NO-2 >> Confirmation after repair: Inspection End.

Diagnosis Procedure

INFOID:000000013444984

CAUTION:

C1115 WHEEL SENSOR

[WITHOUT ICC]

< DTC/CIRCUIT DIAGNOSIS >

Never check between wheel sensor harness connector terminals.

1. CHECK TIRE

Check the tire air pressure, wear and size. Refer to [GI-37, "Wheels & Tires"](#).

Is the inspection result normal?

YES >> GO TO 4.

NO >> Adjust air pressure or replace tire and GO TO 2.

2. CHECK DATA MONITOR (1)

ⓅCONSULT

1. Erase "Self Diagnostic Result" mode of "ABS".

2. Turn the ignition switch OFF → ON → OFF.

NOTE:

Wait at least 10 seconds after turning ignition switch OFF or ON.

3. Start the engine.

4. Select "ABS" and "Data Monitor", check "FR LH SENSOR", "FR RH SENSOR", "RR LH SENSOR" and "RR RH SENSOR".

NOTE:

Set the "Data Monitor" recording speed to "10 msec".

5. Read a value (wheel speed) of both normal wheel sensors and error-detecting wheel sensor.

NOTE:

Vehicle must be driven after repair or replacement to erase the previous DTCs.

Note the difference at 50 km/h (31 MPH) between the wheel speed detected by the error detecting wheel sensor and the maximum/minimum wheel speed detected by the normal wheel sensors. Is the difference within 5%, respectively?

YES >> GO TO 3.

NO >> GO TO 4.

3. PERFORM SELF DIAGNOSTIC RESULT (1)

ⓅCONSULT

1. Stop the vehicle.

2. Turn the ignition switch OFF.

NOTE:

Wait at least 10 seconds after turning ignition switch OFF.

3. Start the engine.

NOTE:

Wait at least 10 seconds after start the engine.

4. Repeat step 2 to 3 two or more times.

5. Select "Self Diagnostic Result" mode of "ABS".

Is DTC "C1115" detected?

YES >> GO TO 4.

NO >> INSPECTION END

4. CHECK ABS ACTUATOR AND ELECTRIC UNIT (CONTROL UNIT) POWER SUPPLY AND GROUND CIRCUIT

Check the ABS actuator and electric unit (control unit) power supply and ground circuit. Refer to [BRC-80, "Diagnosis Procedure"](#).

Is the inspection result normal?

YES >> GO TO 5.

NO >> Repair / replace harness, connector, fuse, or fusible link.

5. CHECK WHEEL SENSOR

1. Turn the ignition switch OFF.

2. Check the wheel sensor for damage.

3. Remove dust and foreign matter adhered to the sensor rotor with a vacuum dust collector through the wheel sensor mounting hole.

CAUTION:

Install wheel sensor with no backlash and float, and tighten the mounting bolt to the specified torque.

C1115 WHEEL SENSOR

[WITHOUT ICC]

< DTC/CIRCUIT DIAGNOSIS >

- **Front:** Refer to [BRC-167, "FRONT WHEEL SENSOR : Exploded View"](#).
- **Rear:** Refer to [BRC-168, "REAR WHEEL SENSOR : Exploded View"](#).

Is the inspection result normal?

- YES >> GO TO 8.
- NO >> GO TO 6.

6. REPLACE WHEEL SENSOR (1)

ⓂCONSULT

1. Replace the wheel sensor.
 - Front: Refer to [BRC-167, "FRONT WHEEL SENSOR : Removal and Installation"](#).
 - Rear: Refer to [BRC-169, "REAR WHEEL SENSOR : Removal and Installation"](#).
2. Erase "Self Diagnostic Result" mode of "ABS".
3. Turn the ignition switch OFF → ON → OFF.

NOTE:

Wait at least 10 seconds after turning ignition switch OFF or ON.

4. Start the engine.
5. Select "ABS" and "Data Monitor", check "FR LH SENSOR", "FR RH SENSOR", "RR LH SENSOR" and "RR RH SENSOR".

NOTE:

Set the "Data Monitor" recording speed to "10 msec".

6. Read a value (wheel speed) of both normal wheel sensors and error-detecting wheel sensor.

NOTE:

Vehicle must be driven after repair or replacement to erase the previous DTCs.

Note the difference at 50 km/h (31 MPH) between the wheel speed detected by the error detecting wheel sensor and the maximum/minimum wheel speed detected by the normal wheel sensors. Is the difference within 5%, respectively?

- YES >> GO TO 7.
- NO >> GO TO 19.

7. PERFORM SELF DIAGNOSTIC RESULT (2)

ⓂCONSULT

1. Stop the vehicle.
2. Turn the ignition switch OFF.
 - NOTE:**
Wait at least 10 seconds after turning ignition switch OFF.
3. Start the engine.
 - NOTE:**
Wait at least 10 seconds after start the engine.
4. Repeat step 2 to 3 two or more times.
5. Select "Self Diagnostic Result" mode of "ABS".

Is DTC "C1115" detected?

- YES >> GO TO 8.
- NO >> Inspection End.

8. CHECK CONNECTOR

1. Turn the ignition switch OFF.
2. Check the ABS actuator and electric unit (control unit) harness connector for disconnection or looseness.
3. Check the wheel sensor harness connector for disconnection or looseness.

Is the inspection result normal?

- YES >> GO TO 11.
- NO >> Repair / replace harness or connector, securely lock the connector, and GO TO 9.

9. CHECK DATA MONITOR (2)

ⓂCONSULT

1. Erase "Self Diagnostic Result" mode of "ABS".
2. Turn the ignition switch OFF → ON → OFF.
 - NOTE:**
Wait at least 10 seconds after turning ignition switch OFF or ON.
3. Start the engine.

A
B
C
D
E
G
H
I
J
K
L
M
N
O
P

BRC

C1115 WHEEL SENSOR

[WITHOUT ICC]

< DTC/CIRCUIT DIAGNOSIS >

4. Select "ABS" and "Data Monitor", check "FR LH SENSOR", "FR RH SENSOR", "RR LH SENSOR" and "RR RH SENSOR".

NOTE:

Set the "Data Monitor" recording speed to "10 msec".

5. Read a value (wheel speed) of both normal wheel sensors and error-detecting wheel sensor.

NOTE:

Vehicle must be driven after repair or replacement to erase the previous DTCs.

Note the difference at 50 km/h (31 MPH) between the wheel speed detected by the error detecting wheel sensor and the maximum/minimum wheel speed detected by the normal wheel sensors. Is the difference within 5%, respectively?

YES >> GO TO 10.

NO >> GO TO 11.

10.PERFORM SELF DIAGNOSTIC RESULT (3)

CONSULT

1. Stop the vehicle.
2. Turn the ignition switch OFF.

NOTE:

Wait at least 10 seconds after turning ignition switch OFF.

3. Start the engine.

NOTE:

Wait at least 10 seconds after start the engine.

4. Repeat step 2 to 3 two or more times.
5. Select "Self Diagnostic Result" mode of "ABS".

Is DTC "C1115" detected?

YES >> GO TO 11.

NO >> Inspection End.

11.CHECK TERMINAL

1. Turn the ignition switch OFF.
2. Disconnect ABS actuator and electric unit (control unit) harness connector and then check the ABS actuator and electric unit (control unit) pin terminals for damage or loose connection with harness connector.
3. Disconnect wheel sensor harness connector and check each wheel sensor pin terminals for damage or loose connection with harness connector.

Is the inspection result normal?

YES >> GO TO 14.

NO >> Repair / replace harness, connector, or terminal, and GO TO 12.

12.CHECK DATA MONITOR (3)

CONSULT

1. Connect ABS actuator and electric unit (control unit) harness connector.
2. Connect wheel sensor harness connector.
3. Erase "Self Diagnostic Result" mode of "ABS".
4. Turn the ignition switch OFF → ON → OFF.

NOTE:

Wait at least 10 seconds after turning ignition switch OFF or ON.

5. Start the engine.
6. Select "ABS" and "Data Monitor", check "FR LH SENSOR", "FR RH SENSOR", "RR LH SENSOR" and "RR RH SENSOR".

NOTE:

Set the "Data Monitor" recording speed to "10 msec".

7. Read a value (wheel speed) of both normal wheel sensors and error-detecting wheel sensor.

NOTE:

Vehicle must be driven after repair or replacement to erase the previous DTCs.

Note the difference at 50 km/h (31 MPH) between the wheel speed detected by the error detecting wheel sensor and the maximum/minimum wheel speed detected by the normal wheel sensors. Is the difference within 5%, respectively?

YES >> GO TO 13.

NO >> GO TO 14.

C1115 WHEEL SENSOR

< DTC/CIRCUIT DIAGNOSIS >

[WITHOUT ICC]

13. PERFORM SELF DIAGNOSTIC RESULT (4)

CONSULT

1. Stop the vehicle.
2. Turn the ignition switch OFF.
NOTE:
Wait at least 10 seconds after turning ignition switch OFF.
3. Start the engine.
NOTE:
Wait at least 10 seconds after start the engine.
4. Repeat step 2 to 3 two or more times.
5. Select "Self Diagnostic Result" mode of "ABS".

Is DTC "C1115" detected?

- YES >> GO TO 14.
NO >> Inspection End.

14. CHECK WHEEL SENSOR HARNESS

1. Turn the ignition switch OFF.
 2. Disconnect ABS actuator and electric unit (control unit) harness connector.
 3. Disconnect wheel sensor harness connector.
 4. Check the continuity between ABS actuator and electric unit (control unit) harness connector and wheel sensor harness connector. (Check continuity while turning steering wheel left and right, or while moving center harness in wheel housing.)
- Measurement connector and terminal for power supply circuit

ABS actuator and electric unit (control unit)		Wheel sensor		Continuity
Connector	Terminal	Connector	Terminal	
E125	19	E18 (Front LH wheel)	1	Yes
	16	E43 (Front RH wheel)		
	31	C10 (Rear LH wheel)		
	17	C11 (Rear RH wheel)		

- Measurement connector and terminal for signal circuit

ABS actuator and electric unit (control unit)		Wheel sensor		Continuity
Connector	Terminal	Connector	Terminal	
E125	8	E18 (Front LH wheel)	2	Yes
	4	E43 (Front RH wheel)		
	18	C10 (Rear LH wheel)		
	29	C11 (Rear RH wheel)		

5. Check the continuity between ABS actuator and electric unit (control unit) harness connector and the ground.

ABS actuator and electric unit (control unit)		—	Continuity
Connector	Terminal		
E125	19, 8	Ground	No
	16, 4		
	31, 18		
	17, 29		

Is the inspection result normal?

- YES >> GO TO 15.
NO >> Repair / replace harness or connector, and GO TO 15.

< DTC/CIRCUIT DIAGNOSIS >

15.CHECK DATA MONITOR (4)

ⓅCONSULT

1. Connect ABS actuator and electric unit (control unit) harness connector.
2. Connect wheel sensor harness connector.
3. Erase "Self Diagnostic Result" mode of "ABS".
4. Turn the ignition switch OFF → ON → OFF.

NOTE:

Wait at least 10 seconds after turning ignition switch OFF or ON.

5. Start the engine.
6. Select "ABS" and "Data Monitor", check "FR LH SENSOR", "FR RH SENSOR", "RR LH SENSOR" and "RR RH SENSOR".

NOTE:

Set the "Data Monitor" recording speed to "10 msec".

7. Read a value (wheel speed) of both normal wheel sensors and error-detecting wheel sensor.

NOTE:

Vehicle must be driven after repair or replacement to erase the previous DTCs.

Note the difference at 50 km/h (31 MPH) between the wheel speed detected by the error detecting wheel sensor and the maximum/minimum wheel speed detected by the normal wheel sensors. Is the difference within 5%, respectively?

YES >> GO TO 16.

NO >> GO TO 17.

16.PERFORM SELF DIAGNOSTIC RESULT (5)

ⓅCONSULT

1. Stop the vehicle.
 2. Turn the ignition switch OFF.
- NOTE:**
Wait at least 10 seconds after turning ignition switch OFF.
3. Start the engine.
- NOTE:**
Wait at least 10 seconds after start the engine.
4. Repeat step 2 to 3 two or more times.
 5. Select "Self Diagnostic Result" mode of "ABS".

Is DTC "C1115" detected?

YES >> GO TO 17.

NO >> Inspection End.

17.REPLACE WHEEL SENSOR (2)

ⓅCONSULT

1. Replace the wheel sensor.
 - Front: Refer to [BRC-167. "FRONT WHEEL SENSOR : Removal and Installation"](#).
 - Rear: Refer to [BRC-169. "REAR WHEEL SENSOR : Removal and Installation"](#).
2. Erase "Self Diagnostic Result" mode of "ABS".
3. Turn the ignition switch OFF → ON → OFF.

NOTE:

Wait at least 10 seconds after turning ignition switch OFF or ON.

4. Start the engine.
5. Select "ABS" and "Data Monitor", check "FR LH SENSOR", "FR RH SENSOR", "RR LH SENSOR" and "RR RH SENSOR".

NOTE:

Set the "Data Monitor" recording speed to "10 msec".

6. Read a value (wheel speed) of both normal wheel sensors and error-detecting wheel sensor.

NOTE:

Vehicle must be driven after repair or replacement to erase the previous DTCs.

Note the difference at 50 km/h (31 MPH) between the wheel speed detected by the error detecting wheel sensor and the maximum/minimum wheel speed detected by the normal wheel sensors. Is the difference within 5%, respectively?

YES >> GO TO 18.

C1115 WHEEL SENSOR

[WITHOUT ICC]

< DTC/CIRCUIT DIAGNOSIS >

NO >> GO TO 19.

18.PERFORM SELF DIAGNOSTIC RESULT(6)

CONSULT

1. Stop the vehicle.
2. Turn the ignition switch OFF.
NOTE:
Wait at least 10 seconds after turning ignition switch OFF.
3. Start the engine.
NOTE:
Wait at least 10 seconds after start the engine.
4. Repeat step 2 to 3 two or more times.
5. Select "Self Diagnostic Result" mode of "ABS".

Is DTC "C1115" detected?

YES >> GO TO 19.

NO >> Inspection End.

19.REPLACE SENSOR ROTOR

CONSULT

1. Replace the sensor rotor.
 - Front: Refer to [BRC-171, "FRONT SENSOR ROTOR : Removal and Installation - Front Sensor Rotor"](#).
 - Rear: Refer to [BRC-171, "REAR SENSOR ROTOR : Removal and Installation - Rear Sensor Rotor"](#).
2. Erase "Self Diagnostic Result" mode of "ABS".
3. Turn the ignition switch OFF → ON → OFF.
NOTE:
Wait at least 10 seconds after turning ignition switch OFF or ON.
4. Start the engine.
5. Drive the vehicle at approx. 50 km/h (31 MPH) or more for approx. 2 minutes.
NOTE:
Vehicle must be driven after repair or replacement to erase the previous DTCs.
6. Stop the vehicle.
7. Turn the ignition switch OFF.
NOTE:
Wait at least 10 seconds after turning ignition switch OFF.
8. Start the engine.
NOTE:
Wait at least 10 seconds after start the engine.
9. Repeat step 7 to 8 two or more times.
10. Select "Self Diagnostic Result" mode of "ABS".

Is DTC "C1115" detected?

YES >> Replace the ABS actuator and electric unit (control unit). Refer to [BRC-172, "Removal and Installation"](#).

NO >> Inspection End.

A
B
C
D
E
BRC
G
H
I
J
K
L
M
N
O
P

C1116 STOP LAMP SWITCH

< DTC/CIRCUIT DIAGNOSIS >

[WITHOUT ICC]

C1116 STOP LAMP SWITCH

DTC Description

INFOID:000000013445028

DTC DETECTION LOGIC

DTC	Display Item (Trouble diagnosis content)	Malfunction detected condition
C1116	STOP LAMP SW (Stop lamp switch)	When stop lamp switch signal is not inputted when brake pedal operates.

POSSIBLE CAUSE

NOTE:

Confirm if DTC is PAST or CRNT. If DTC is CRNT, proceed with Diagnosis Procedure. If DTC is PAST, clear the DTC. Do not replace the ABS actuator and electric unit (control unit) for a PAST DTC.

PAST DTC	CRNT DTC
<ul style="list-style-type: none">• Harness or connector• Stop lamp switch signal circuit	<ul style="list-style-type: none">• Harness or connector• Stop lamp relay• Stop lamp switch• ABS actuator and electric unit (control unit)• ABS actuator and electric unit (control unit) power supply system• Fuse• Fusible link• Battery

DTC CONFIRMATION PROCEDURE

1. PRECONDITIONING

If "DTC CONFIRMATION PROCEDURE" has been previously conducted, always turn the ignition switch OFF and wait at least 10 seconds before conducting the next test.

>> GO TO 2.

2. CHECK DTC DETECTION

CONSULT

1. Turn the ignition switch OFF, and wait 10 seconds or more.
2. Start the engine.

NOTE:

Stop the vehicle.

3. Wait 1 minute or more.

NOTE:

Never depress brake pedal.

4. Depress brake pedal by 100 mm (3.94 in) or more, and maintain that position for a minimum of 1 minute or more.
5. Release brake pedal, and wait 1 minute or more.
6. Repeat steps 4 through 5 ten or more times.
7. Turn the ignition switch OFF.

NOTE:

Wait at least 10 seconds after turning ignition switch OFF.

8. Start the engine.

NOTE:

Wait at least 10 seconds after starting the engine.

9. Select "Self Diagnostic Result" mode of "ABS".

Is DTC "C1116" detected?

- YES-1 >> "C1116" is displayed as "CRNT": Proceed to [BRC-97, "Diagnosis Procedure"](#).
YES-2 >> "C1116" is displayed as "PAST": Inspection End. (Erase "Self Diagnostic Result" of "ABS".)
NO-1 >> To check malfunction symptom before repair: Refer to [GI-42, "Intermittent Incident"](#).
NO-2 >> Confirmation after repair: Inspection End.

C1116 STOP LAMP SWITCH

< DTC/CIRCUIT DIAGNOSIS >

[WITHOUT ICC]

Diagnosis Procedure

INFOID:000000013445029

NOTE:

DTC "C1116" may be detected when the brake pedal and the accelerator pedal are simultaneously depressed for 1 minute or more while driving the vehicle. This is not a malfunction.

1. INTERVIEW FROM THE CUSTOMER

Check if the brake pedal and the accelerator pedal are simultaneously depressed for 1 minute or more while driving the vehicle.

Is there such a history?

YES >> GO TO 2.

NO >> GO TO 3.

2. PERFORM SELF-DIAGNOSIS

CONSULT

1. Erase "Self Diagnostic Result" mode of "ABS"

2. Turn the ignition switch OFF → ON → OFF.

NOTE:

Wait at least 10 seconds after turning ignition switch OFF or ON.

3. Start the engine.

NOTE:

Stop the vehicle.

4. Depress the brake pedal several times.

5. Turn the ignition switch OFF.

NOTE:

Wait at least 10 seconds after turning ignition switch OFF.

6. Start the engine.

NOTE:

Wait at least 10 seconds after starting the engine.

7. Select "Self Diagnostic Result" mode of "ABS".

Is DTC "C1116" detected?

YES >> GO TO 3.

NO >> Inspection End.

3. STOP LAMP FOR ILLUMINATION

Depress brake pedal and check that stop lamp turns ON.

Does stop lamp turn ON?

YES >> GO TO 5.

NO >> Check the stop lamp system. Refer to [EXL-60. "Wiring Diagram"](#). GO TO 4.

4. CHECK DATA MONITOR (1)

CONSULT

1. Erase "Self Diagnostic Result" mode of "ABS"

2. Turn the ignition switch OFF → ON → OFF.

NOTE:

Wait at least 10 seconds after turning ignition switch OFF or ON.

3. Start the engine.

NOTE:

Stop the vehicle.

4. Select "Data Monitor" mode of "ABS", check "STOP LAMP SW". Check that data monitor displays "On" or "Off" when brake pedal is depressed or released. Refer to [BRC-44. "Reference Value"](#).

5. Select "Data Monitor" mode of "ABS", check "PRESS SENSOR". Depress the brake pedal and check if "PRESS SENSOR" indicates "5 bar" or less when "STOP LAMP SW" of "Data Monitor" turns "Off" or "On". Refer to [BRC-44. "Reference Value"](#).

Is the inspection result normal?

YES >> Inspection End.

NO >> GO TO 5.

5. CHECK CONNECTOR

A

B

C

D

E

BRC

G

H

I

J

K

L

M

N

O

P

C1116 STOP LAMP SWITCH

[WITHOUT ICC]

< DTC/CIRCUIT DIAGNOSIS >

1. Turn the ignition switch OFF.
2. Check the ABS actuator and electric unit (control unit) harness connector for disconnection or looseness.
3. Check the stop lamp switch harness connector for disconnection or looseness.

Is the inspection result normal?

- YES >> GO TO 6.
NO >> Repair / replace harness or connector, and GO TO 6.

6. CHECK ABS ACTUATOR AND ELECTRIC UNIT (CONTROL UNIT) POWER SUPPLY AND GROUND CIRCUIT

Check the ABS actuator and electric unit (control unit) power supply and ground circuits. Refer to [BRC-80. "Diagnosis Procedure"](#).

Is the inspection result normal?

- YES >> GO TO 7.
NO >> Repair / replace harness, connector, fuse, or fusible link.

7. CHECK STOP LAMP SWITCH CLEARANCE

1. Turn the ignition switch OFF.
2. Check the stop lamp switch clearance. Refer to [BR-7. "Inspection"](#).

Is the inspection result normal?

- YES >> GO TO 9.
NO >> Adjust stop lamp switch clearance. Refer to [BR-13. "Adjustment"](#). GO TO 8.

8. CHECK DATA MONITOR (2)

CONSULT

1. Erase "Self Diagnostic Result" mode of "ABS"
2. Turn the ignition switch OFF → ON → OFF.
NOTE:
Wait at least 10 seconds after turning ignition switch OFF or ON.
3. Start the engine.
NOTE:
Stop the vehicle.
4. Select "DATA MONITOR" mode of "ABS", check "STOP LAMP SW". Check that data monitor displays "On" or "Off" when brake pedal is depressed or released. Refer to [BRC-44. "Reference Value"](#).
5. Select "Data Monitor" mode of "ABS", check "PRESS SENSOR". Depress the brake pedal and check if "PRESS SENSOR" indicates "5 bar" or less when "STOP LAMP SW" of "Data Monitor" turns "Off" or "On". Refer to [BRC-44. "Reference Value"](#).

Is the inspection result normal?

- YES >> Inspection End.
NO >> GO TO 9.

9. CHECK STOP LAMP SWITCH

Check the stop lamp switch. Refer to [BR-7. "Inspection"](#).

Is the inspection result normal?

- YES >> GO TO 10.
NO >> Replace the stop lamp switch. Refer to [BR-20. "Exploded View"](#). GO TO 10.

10. CHECK DATA MONITOR (3)

CONSULT

1. Erase "Self Diagnostic Result" mode of "ABS"
2. Turn the ignition switch OFF → ON → OFF.
NOTE:
Wait at least 10 seconds after turning ignition switch OFF or ON.
3. Start the engine.
NOTE:
Start the vehicle.
4. Select "DATA MONITOR" mode of "ABS", check "STOP LAMP SW". Check that data monitor displays "On" or "Off" when brake pedal is depressed or released. Refer to [BRC-44. "Reference Value"](#).

C1116 STOP LAMP SWITCH

[WITHOUT ICC]

< DTC/CIRCUIT DIAGNOSIS >

- Select "Data Monitor" mode of "ABS", check "PRESS SENSOR". Depress the brake pedal and check if "PRESS SENSOR" indicates "5 bar" or less when "STOP LAMP SW" of "Data Monitor" turns "Off" or "On". Refer to [BRC-44. "Reference Value"](#).

Is the inspection result normal?

- YES >> Inspection End.
NO >> GO TO 11.

11. CHECK CONNECTOR AND TERMINAL

- Turn the ignition switch OFF.
- Disconnect ABS actuator and electric unit (control unit) harness connector.
- Check the ABS actuator and electric unit (control unit) harness connector for disconnection or looseness.
- Check the ABS actuator and electric unit (control unit) pin terminals for damage or loose connection with harness connector.
- Disconnect stop lamp switch harness connector.
- Check the stop lamp switch harness connector for disconnection or looseness.
- Check the stop lamp switch pin terminals for damage or loose connection with harness connector.

Is the inspection result normal?

- YES >> GO TO 13.
NO >> Repair / replace harness, connector, or terminal, and GO TO 12.

12. CHECK DATA MONITOR (4)

ⓂCONSULT

- Connect ABS actuator and electric unit (control unit) harness connector.
- Connect stop lamp switch harness connector.
- Erase "Self Diagnostic Result" mode of "ABS"
- Turn the ignition switch OFF → ON → OFF.
NOTE:
Wait at least 10 seconds after turning ignition switch OFF or ON.
- Start the engine.
NOTE:
Stop the vehicle.
- Select "DATA MONITOR" mode of "ABS", check "STOP LAMP SW". Check that data monitor displays "On" or "Off" when brake pedal is depressed or released. Refer to [BRC-44. "Reference Value"](#).
- Select "Data Monitor" mode of "ABS", check "PRESS SENSOR". Depress the brake pedal and check if "PRESS SENSOR" indicates "5 bar" or less when "STOP LAMP SW" of "Data Monitor" turns "Off" or "On". Refer to [BRC-44. "Reference Value"](#).

Is the inspection result normal?

- YES >> Inspection End.
NO >> GO TO 13.

13. CHECK STOP LAMP SWITCH CIRCUIT (1)

- Turn the ignition switch OFF.
- Disconnect ABS actuator and electric unit (control unit) harness connector.
- Check the voltage between ABS actuator and electric unit (control unit) harness connector and ground.

ABS actuator and electric unit (control unit)		—	Condition	Voltage
Connector	Terminal			
E125	30	Ground	Brake pedal depressed	Battery voltage (Approx.)
			Brake pedal not depressed	Approx. 0 V

- Turn the ignition switch ON.
- Check the voltage between ABS actuator and electric unit (control unit) harness connector and ground.

C1116 STOP LAMP SWITCH

< DTC/CIRCUIT DIAGNOSIS >

[WITHOUT ICC]

ABS actuator and electric unit (control unit)		—	Condition	Voltage
Connector	Terminal			
E125	30	Ground	Brake pedal depressed	Battery voltage (Approx.)
			Brake pedal not depressed	Approx. 0 V

Is the inspection result normal?

YES >> Replace the ABS actuator and electric unit (control unit). Refer to [BRC-172, "Removal and Installation"](#).

NO >> Repair / replace harness or connector, and GO TO 14.

14.CHECK STOP LAMP SWITCH CIRCUIT

- Turn the ignition switch OFF.
- Disconnect stop lamp switch harness connector.
- Check the continuity between ABS actuator and electric unit (control unit) harness connector and stop lamp switch harness connector.

ABS actuator and electric unit (control unit)		Stop lamp switch		Continuity
Connector	Terminal	Connector	Terminal	
E125	30	E38	2	Yes

- Check the continuity between ABS actuator and electric unit (control unit) harness connector and the ground.

ABS actuator and electric unit (control unit)		—	Continuity
Connector	Terminal		
E125	30	Ground	No

Is the inspection result normal?

YES >> Replace the ABS actuator and electric unit (control unit). Refer to [BRC-172, "Removal and Installation"](#).

NO >> Repair / replace harness or connector, and GO TO 15.

15.CHECK DATA MONITOR (5)

CONSULT

- Connect ABS actuator and electric unit (control unit) harness connector.
- Connect stop lamp switch harness connector.
- Erase "Self Diagnostic Result" mode of "ABS".
- Turn the ignition switch OFF → ON → OFF.
NOTE:
Wait at least 10 seconds after turning ignition switch OFF or ON.
- Start the engine.
NOTE:
Stop the vehicle.
- Select "DATA MONITOR" mode of "ABS", check "STOP LAMP SW". Check that data monitor displays "On" or "Off" when brake pedal is depressed or released. Refer to [BRC-44, "Reference Value"](#).
- Select "Data Monitor" mode of "ABS", check "PRESS SENSOR". Depress the brake pedal and check if "PRESS SENSOR" indicates "5 bar" or less when "STOP LAMP SW" of "Data Monitor" turns "Off" or "On". Refer to [BRC-44, "Reference Value"](#).

Is the inspection result normal?

YES >> Inspection End.

NO >> Replace the ABS actuator and electric unit (control unit). Refer to [BRC-172, "Removal and Installation"](#).

Component Inspection

INFOID:000000013445030

1.CHECK STOP LAMP SWITCH

C1116 STOP LAMP SWITCH

< DTC/CIRCUIT DIAGNOSIS >

[WITHOUT ICC]

1. Turn the ignition switch OFF.
2. Disconnect stop lamp switch harness connector.
3. Check the continuity when stop lamp switch is operated.

Stop lamp switch Terminals	Condition	Continuity
1-2	When stop lamp switch is released (When brake pedal is depressed)	Yes
	When stop lamp switch is pressed (When brake pedal is released)	No

Is the inspection result normal?

YES >> Inspection End.

NO >> Replace the stop lamp switch. Refer to [BR-20, "Exploded View"](#).

A
B
C
D
E
G
H
I
J
K
L
M
N
O
P

BRC

C1120, C1122, C1124, C1126 ABS IN VALVE SYSTEM

< DTC/CIRCUIT DIAGNOSIS >

[WITHOUT ICC]

C1120, C1122, C1124, C1126 ABS IN VALVE SYSTEM

DTC Description

INFOID:000000013444988

DTC DETECTION LOGIC

DTC	Display Item (Trouble diagnosis content)	Malfunction detected condition
C1120	FR LH IN ABS SOL (Front LH ABS IN solenoid valve)	When a malfunction is detected in front LH ABS IN valve.
C1122	FR RH IN ABS SOL (Front RH ABS IN solenoid valve)	When a malfunction is detected in front RH ABS IN valve.
C1124	RR LH IN ABS SOL (Rear LH ABS IN solenoid valve)	When a malfunction is detected in rear LH ABS IN valve.
C1126	RR RH IN ABS SOL (Rear RH ABS IN solenoid valve)	When a malfunction is detected in rear RH ABS IN valve.

POSSIBLE CAUSE

NOTE:

Confirm if DTC is PAST or CRNT. If DTC is CRNT, proceed with Diagnosis Procedure. If DTC is PAST, clear DTC. Do not replace the ABS actuator and electric unit (control unit) for a PAST DTC.

PAST DTC	CRNT DTC
<ul style="list-style-type: none">• Harness or connector• ABS actuator and electric unit (control unit) power supply system• Fuse• Fusible link• Battery	<ul style="list-style-type: none">• Harness or connector• ABS actuator and electric unit (control unit)• ABS actuator and electric unit (control unit) power supply system• Fuse• Fusible link• Battery

DTC CONFIRMATION PROCEDURE

1. PRECONDITIONING

If "DTC CONFIRMATION PROCEDURE" has been previously conducted, always turn the ignition switch OFF and wait at least 10 seconds before conducting the next test.

>> GO TO 2.

2. CHECK DTC DETECTION

ⓑ CONSULT

1. Turn the ignition switch OFF.

NOTE:

Wait at least 10 seconds after turning ignition switch OFF.

2. Start the engine.

NOTE:

Wait at least 10 seconds after start the engine.

3. Repeat step 1 to 2 two or more times.

4. Select "Self Diagnostic Result" mode of "ABS".

Is DTC "C1120", "C1122", "C1124" or "C1126" detected?

YES-1 >> "C1120", "C1122", "C1124" or "C1126" is displayed by "CRNT": Proceed to [BRC-103, "Diagnosis Procedure"](#).

YES-2 >> "C1120", "C1122", "C1124" or "C1126" is displayed by "PAST": Inspection End (Erase the memory of "Self Diagnostic Result" mode of "ABS".)

NO-1 >> To check malfunction symptom before repair: Refer to [GI-42, "Intermittent Incident"](#).

NO-2 >> Confirmation after repair: Inspection End.

C1120, C1122, C1124, C1126 ABS IN VALVE SYSTEM

< DTC/CIRCUIT DIAGNOSIS >

[WITHOUT ICC]

INFOID:000000013444989

Diagnosis Procedure

1. CHECK CONNECTOR

1. Turn the ignition switch OFF.
2. Check the ABS actuator and electric unit (control unit) harness connector for disconnection or looseness.

Is the inspection result normal?

YES >> GO TO 3.

NO >> Repair / replace harness or connector, securely lock the connector, and GO TO 2.

2. PERFORM SELF DIAGNOSTIC RESULT

CONSULT

1. Turn the ignition switch OFF.
NOTE:
Wait at least 10 seconds after turning ignition switch OFF.
2. Start the engine.
NOTE:
Wait at least 10 seconds after start the engine.
3. Repeat step 1 to 2 two or more times.
4. Select "Self Diagnostic Result" mode of "ABS".

Is DTC "C1120", "C1122", "C1124" or "C1126" detected?

YES >> GO TO 3.

NO >> Inspection End.

3. CHECK ABS ACTUATOR AND ELECTRIC UNIT (CONTROL UNIT) POWER SUPPLY AND GROUND CIRCUIT

Check the ABS actuator and electric unit (control unit) power supply and ground circuit. Refer to [BRC-80, "Diagnosis Procedure"](#).

Is the inspection result normal?

YES >> GO TO 4.

NO >> Repair / replace harness, connector, fuse, or fusible link.

4. CHECK TERMINAL

Check the ABS actuator and electric unit (control unit) pin terminals for damage or loose connection with harness connector.

Is the inspection result normal?

YES >> Replace the ABS actuator and electric unit (control unit). Refer to [BRC-172, "Removal and Installation"](#).

NO >> Repair / replace harness, connector, or terminal.

A
B
C
D
E
BRC
G
H
I
J
K
L
M
N
O
P

C1121, C1123, C1125, C1127 ABS OUT VALVE SYSTEM

< DTC/CIRCUIT DIAGNOSIS >

[WITHOUT ICC]

C1121, C1123, C1125, C1127 ABS OUT VALVE SYSTEM

DTC Description

INFOID:000000013444990

DTC DETECTION LOGIC

DTC	Display Item (Trouble diagnosis content)	Malfunction detected condition
C1121	FR LH OUT ABS SOL (Front LH ABS OUT solenoid valve)	When a malfunction is detected in front LH ABS OUT valve.
C1123	FR RH OUT ABS SOL (Front RH ABS OUT solenoid valve)	When a malfunction is detected in front RH ABS OUT valve.
C1125	RR LH OUT ABS SOL (Rear LH ABS OUT solenoid valve)	When a malfunction is detected in rear LH ABS OUT valve.
C1127	RR RH OUT ABS SOL (Rear RH ABS OUT solenoid valve)	When a malfunction is detected in rear RH ABS OUT valve.

POSSIBLE CAUSE

NOTE:

Confirm if DTC is PAST or CRNT. If DTC is CRNT, proceed with Diagnosis Procedure. If DTC is PAST, clear DTC. Do not replace the ABS actuator and electric unit (control unit) for a PAST DTC.

PAST DTC	CRNT DTC
<ul style="list-style-type: none">• Harness or connector• ABS actuator and electric unit (control unit) power supply system• Fuse• Fusible link• Battery	<ul style="list-style-type: none">• Harness or connector• ABS actuator and electric unit (control unit)• ABS actuator and electric unit (control unit) power supply system• Fuse• Fusible link• Battery

DTC CONFIRMATION PROCEDURE

1. PRECONDITIONING

If "DTC CONFIRMATION PROCEDURE" has been previously conducted, always turn the ignition switch OFF and wait at least 10 seconds before conducting the next test.

>> GO TO 2.

2. CHECK DTC DETECTION

ⓑ CONSULT

1. Turn the ignition switch OFF.

NOTE:

Wait at least 10 seconds after turning ignition switch OFF.

2. Start the engine.

NOTE:

Wait at least 10 seconds after start the engine.

3. Repeat step 1 to 2 two or more times.

4. Select "Self Diagnostic Result" mode of "ABS".

Is DTC "C1121", "C1123", "C1125" or "C1127" detected?

YES-1 >> "C1121", "C1123", "C1125" or "C1127" is displayed by "CRNT": Proceed to [BRC-105, "Diagnosis Procedure"](#).

YES-2 >> "C1121", "C1123", "C1125" and "C1127" are displayed by "PAST": Inspection End (Erase the memory of "Self Diagnostic Result" mode of "ABS".)

NO-1 >> To check malfunction symptom before repair: Refer to [GI-42, "Intermittent Incident"](#).

NO-2 >> Confirmation after repair: Inspection End.

C1121, C1123, C1125, C1127 ABS OUT VALVE SYSTEM

< DTC/CIRCUIT DIAGNOSIS >

[WITHOUT ICC]

INFOID:000000013444991

Diagnosis Procedure

1. CHECK CONNECTOR

1. Turn the ignition switch OFF.
2. Check the ABS actuator and electric unit (control unit) harness connector for disconnection or looseness.

Is the inspection result normal?

YES >> GO TO 3.

NO >> Repair / replace harness or connector, securely lock the connector, and GO TO 2.

2. SELECT SELF DIAGNOSTIC RESULT

1. Turn the ignition switch OFF.
NOTE:
Wait at least 10 seconds after turning ignition switch OFF.

2. Start the engine.

NOTE:

Wait at least 10 seconds after start the engine.

3. Repeat step 1 to 2 two or more times.
4. Select "Self Diagnostic Result" mode of "ABS".

Is DTC "C1121", "C1123", "C1125" or "C1127" detected?

YES >> GO TO 3.

NO >> Inspection End.

3. CHECK ABS ACTUATOR AND ELECTRIC UNIT (CONTROL UNIT) POWER SUPPLY AND GROUND CIRCUIT

Check the ABS actuator and electric unit (control unit) power supply and ground circuit. Refer to [BRC-80, "Diagnosis Procedure"](#).

Is the inspection result normal?

YES >> GO TO 4.

NO >> Repair / replace harness, connector, fuse, or fusible link.

4. CHECK TERMINAL

Check the ABS actuator and electric unit (control unit) pin terminals for damage or loose connection with harness connector.

Is the inspection result normal?

YES >> Replace the ABS actuator and electric unit (control unit). Refer to [BRC-172, "Removal and Installation"](#).

NO >> Repair / replace harness, connector, or terminal.

A
B
C
D
E
BRC
G
H
I
J
K
L
M
N
O
P

C1130 ENGINE SIGNAL

DTC Description

INFOID:000000013444992

DTC DETECTION LOGIC

DTC	Display Item (Trouble diagnosis content)	Malfunction detected condition
C1130	ENGINE SIGNAL 1 (Engine system signal)	When a malfunction is detected in ECM system.

POSSIBLE CAUSE

NOTE:

Confirm if DTC is PAST or CRNT. If DTC is CRNT, proceed with Diagnosis Procedure. If DTC is PAST, clear DTC. Do not replace the ABS actuator and electric unit (control unit) for a PAST DTC.

PAST DTC	CRNT DTC
<ul style="list-style-type: none"> • Harness or connector • ABS actuator and electric unit (control unit) power supply system • Fuse • Fusible link • Battery • CAN communication line 	<ul style="list-style-type: none"> • Harness or connector • ECM • ABS actuator and electric unit (control unit) • ABS actuator and electric unit (control unit) power supply system • Fuse • Fusible link • Battery • CAN communication line

DTC CONFIRMATION PROCEDURE

1. PRECONDITIONING

If "DTC CONFIRMATION PROCEDURE" has been previously conducted, always turn the ignition switch OFF and wait at least 10 seconds before conducting the next test.

>> GO TO 2.

2. CHECK DTC DETECTION

CONSULT

1. Turn the ignition switch OFF.
NOTE:
Wait at least 10 seconds after turning ignition switch OFF.
2. Start the engine.
NOTE:
Wait at least 10 seconds after start the engine.
3. Repeat step 1 to 2 two or more times.
4. Select "Self Diagnostic Result" mode of "ABS".

Is DTC "C1130" detected?

- YES-1 >> "CRNT" is displayed: Proceed to [BRC-106, "Diagnosis Procedure"](#).
- YES-2 >> "PAST" is displayed: Inspection End (Erase the memory of "Self Diagnostic Result" mode of "ABS".)
- NO-1 >> To check malfunction symptom before repair: Refer to [GI-42, "Intermittent Incident"](#).
- NO-2 >> Confirmation after repair: Inspection End.

Diagnosis Procedure

INFOID:000000013444993

1. CHECK ENGINE SYSTEM

CONSULT

Select "Self Diagnostic Result" mode of "ENGINE".

Is DTC detected?

- YES >> Check the DTC. Refer to [EC-105, "DTC Index"](#) (VQ35DE).

C1130 ENGINE SIGNAL

[WITHOUT ICC]

< DTC/CIRCUIT DIAGNOSIS >

NO >> GO TO 2.

2. CHECK ABS ACTUATOR AND ELECTRIC UNIT (CONTROL UNIT) POWER SUPPLY AND GROUND CIRCUIT

Check the ABS actuator and electric unit (control unit) power supply and ground circuit. Refer to [BRC-80, "Diagnosis Procedure"](#).

Is the inspection result normal?

YES >> GO TO 3.

NO >> Repair / replace harness, connector, fuse, or fusible link.

3. CHECK CONNECTOR AND TERMINAL

1. Turn the ignition switch OFF.
2. Disconnect ECM harness connector.
3. Disconnect ABS actuator and electric unit (control unit) harness connector.
4. Check the connector for disconnection or looseness.
5. Check the pin terminals for damage or loose connection with harness connector.

Is the inspection result normal?

YES >> GO TO 4.

NO >> Repair / replace harness, connector, or terminal, securely lock the connector, and GO TO 4.

4. CHECK ABS ACTUATOR AND ELECTRIC UNIT (CONTROL UNIT)

CONSULT

1. Connect ECM harness connector.
2. Connect ABS actuator and electric unit (control unit) harness connector.
3. Erase "Self Diagnostic Result" mode of "ABS".
4. Turn the ignition switch OFF.
NOTE:
Wait at least 10 seconds after turning ignition switch OFF.
5. Start the engine.
NOTE:
Wait at least 10 seconds after start the engine.
6. Repeat step 4 to 5 two or more times.
7. Select "Self Diagnostic Result" mode of "ABS".

Is DTC "C1130" or "U1000" detected?

YES ("C1130") >> GO TO 1.

YES ("U1000") >> Refer to [LAN-21, "Trouble Diagnosis Flow Chart"](#).

NO >> Inspection End.

A
B
C
D
E
BRC
G
H
I
J
K
L
M
N
O
P

C1140 ACTUATOR RELAY SYSTEM

< DTC/CIRCUIT DIAGNOSIS >

[WITHOUT ICC]

C1140 ACTUATOR RELAY SYSTEM

DTC Description

INFOID:000000013444994

DTC DETECTION LOGIC

DTC	Display Item (Trouble diagnosis content)	Malfunction detected condition
C1140	ACTUATOR RLY (Actuator relay)	When a malfunction is detected in actuator relay.

POSSIBLE CAUSE

NOTE:

Confirm if DTC is PAST or CRNT. If DTC is CRNT, proceed with Diagnosis Procedure. If DTC is PAST, clear DTC. Do not replace the ABS actuator and electric unit (control unit) for a PAST DTC.

PAST DTC	CRNT DTC
<ul style="list-style-type: none">• Harness or connector• ABS actuator and electric unit (control unit) power supply system• Fuse• Fusible link• Battery	<ul style="list-style-type: none">• Harness or connector• ABS actuator and electric unit (control unit)• ABS actuator and electric unit (control unit) power supply system• Fuse• Fusible link• Battery

DTC CONFIRMATION PROCEDURE

1. PRECONDITIONING

If "DTC CONFIRMATION PROCEDURE" has been previously conducted, always turn the ignition switch OFF and wait at least 10 seconds before conducting the next test.

>> GO TO 2.

2. CHECK DTC DETECTION

ⓑ CONSULT

1. Turn the ignition switch OFF.

NOTE:

Wait at least 10 seconds after turning ignition switch OFF.

2. Start the engine.

NOTE:

Wait at least 10 seconds after start the engine.

3. Repeat step 1 to 2 two or more times.

4. Select "Self Diagnostic Result" mode of "ABS".

Is DTC "C1140" detected?

YES-1 >> "CRNT" is displayed: Proceed to [BRC-108. "Diagnosis Procedure"](#).

YES-2 >> "PAST" is displayed: Inspection End (Erase the memory of "Self Diagnostic Result" mode of "ABS".)

NO-1 >> To check malfunction symptom before repair: Refer to [GI-42. "Intermittent Incident"](#).

NO-2 >> Confirmation after repair: Inspection End.

Diagnosis Procedure

INFOID:000000013444995

1. CHECK CONNECTOR

1. Turn the ignition switch OFF.

2. Check the ABS actuator and electric unit (control unit) harness connector for disconnection or looseness.

Is the inspection result normal?

YES >> GO TO 3.

NO >> Repair / replace harness or connector, securely lock the connector, and GO TO 2.

C1140 ACTUATOR RELAY SYSTEM

< DTC/CIRCUIT DIAGNOSIS >

[WITHOUT ICC]

2. PERFORM SELF DIAGNOSTIC RESULT

CONSULT

1. Turn the ignition switch OFF.

NOTE:

Wait at least 10 seconds after turning ignition switch OFF.

2. Start the engine.

NOTE:

Wait at least 10 seconds after start the engine.

3. Repeat step 1 to 2 two or more times.

4. Select "Self Diagnostic Result" mode of "ABS".

Is DTC "C1140" detected?

YES >> GO TO 3.

NO >> Inspection End.

3. CHECK ABS ACTUATOR AND ELECTRIC UNIT (CONTROL UNIT) POWER SUPPLY AND GROUND CIRCUIT

Check the ABS actuator and electric unit (control unit) power supply and ground circuit. Refer to [BRC-80, "Diagnosis Procedure"](#).

Is the inspection result normal?

YES >> GO TO 4.

NO >> Repair / replace harness, connector, fuse, or fusible link.

4. CHECK TERMINAL

Check the ABS actuator and electric unit (control unit) pin terminals for damage or loose connection with harness connector.

Is the inspection result normal?

YES >> Replace the ABS actuator and electric unit (control unit). Refer to [BRC-172, "Removal and Installation"](#).

NO >> Repair / replace harness, connector, or terminal.

A
B
C
D
E
G
H
I
J
K
L
M
N
O
P

BRC

C1142 PRESS SENSOR

DTC Description

INFOID:000000013444996

DTC DETECTION LOGIC

DTC	Display Item (Trouble diagnosis content)	Malfunction detected condition
C1142	PRESS SEN CIRCUIT (Pressure sensor circuit)	When a malfunction is detected in pressure sensor.

POSSIBLE CAUSE

NOTE:

Confirm if DTC is PAST or CRNT. If DTC is CRNT, proceed with Diagnosis Procedure. If DTC is PAST, clear DTC. Do not replace the ABS actuator and electric unit (control unit) for a PAST DTC.

PAST DTC	CRNT DTC
<ul style="list-style-type: none"> • Harness or connector • Air inclusion in the brake piping • Stop lamp switch system • ABS actuator and electric unit (control unit) power supply system • Fuse • Fusible link • Battery 	<ul style="list-style-type: none"> • Harness or connector • Stop lamp switch system • ABS actuator and electric unit (control unit) • Brake system • ABS actuator and electric unit (control unit) power supply system • Fuse • Fusible link • Battery • Air inclusion in the brake piping

DTC CONFIRMATION PROCEDURE

1. PRECONDITIONING

If "DTC CONFIRMATION PROCEDURE" has been previously conducted, always turn the ignition switch OFF and wait at least 10 seconds before conducting the next test.

>> GO TO 2.

2. CHECK DTC DETECTION

CONSULT

1. Turn the ignition switch OFF.
NOTE:
Wait at least 10 seconds after turning ignition switch OFF.
2. Start the engine.
NOTE:
Wait at least 10 seconds after start the engine.
3. Repeat step 1 to 2 two or more times.
4. Select "Self Diagnostic Result" mode of "ABS".

Is DTC "C1142" detected?

- YES-1 >> "CRNT" is displayed: Proceed to [BRC-110. "Diagnosis Procedure"](#).
 YES-2 >> "PAST" is displayed: Inspection End (Erase the memory of self-diagnosis results.)
 NO-1 >> To check malfunction symptom before repair: Refer to [GI-42. "Intermittent Incident"](#).
 NO-2 >> Confirmation after repair: Inspection End.

Diagnosis Procedure

INFOID:000000013444997

1. CHECK STOP LAMP SWITCH SYSTEM

Check the stop lamp switch system. Refer to [EXL-181. "Wiring Diagram"](#).

Is the inspection result normal?

- YES >> GO TO 2.
 NO >> Repair or replace stop lamp switch system.

< DTC/CIRCUIT DIAGNOSIS >

2.CHECK BRAKE FLUID LEAKAGE

Check the brake fluid leakage. Refer to [BR-8, "Inspection"](#).

Is the inspection result normal?

YES >> GO TO 3.

NO >> Repair or replace brake fluid leakage part.

3.CHECK BRAKE PIPING

Check the brake piping.

- Front: Refer to [BR-22, "FRONT : Exploded View"](#).
- Rear: Refer to [BR-26, "REAR : Exploded View"](#).

Is the inspection result normal?

YES >> GO TO 4.

NO >> Repair or replace brake piping.

- Front: Refer to [BR-24, "FRONT : Removal and Installation"](#).
- Rear: Refer to [BR-27, "REAR : Removal and Installation"](#).

4.CHECK BRAKE PEDAL

Check the brake pedal.

- Brake pedal height: Refer to [BR-7, "Inspection"](#).
- Brake pedal assembly: Refer to [BR-7, "Inspection"](#).

Is the inspection result normal?

YES >> GO TO 5.

NO >> Adjust the brake pedal height or replace brake pedal assembly.

- Adjust the brake pedal: Refer to [BR-7, "Inspection"](#).
- Replace the brake pedal: Refer to [BR-20, "Removal and Installation"](#).

5.CHECK BRAKE MASTER CYLINDER

Check the brake master cylinder. Refer to [BR-9, "Inspection"](#).

Is the inspection result normal?

YES >> GO TO 6.

NO >> Repair or replace brake master cylinder. Refer to [BR-29, "Removal and Installation"](#).

6.CHECK BRAKE BOOSTER

Check the brake booster. Refer to [BR-10, "Inspection"](#).

Is the inspection result normal?

YES >> GO TO 7.

NO >> Repair or replace brake booster. Refer to [BR-32, "Removal and Installation"](#).

7.CHECK VACUUM PIPING

Check the vacuum piping. Refer to [BR-34, "Exploded View"](#).

Is the inspection result normal?

YES >> GO TO 8.

NO >> Repair or replace vacuum piping. Refer to [BR-34, "Removal and Installation"](#).

8.CHECK FRONT DISC BRAKE

Check the front disc brake.

- [BR-16, "DISC BRAKE ROTOR : Inspection"](#).

Is the inspection result normal?

YES >> GO TO 9.

NO >> Repair or replace front disc brake.

- Refer to [BR-40, "DISC BRAKE ROTOR : Removal and Installation"](#).

9.CHECK REAR DISC BRAKE

Check the rear disc brake.

- Refer to [BR-18, "DISC BRAKE ROTOR : Inspection"](#).

Is the inspection result normal?

C1142 PRESS SENSOR

[WITHOUT ICC]

< DTC/CIRCUIT DIAGNOSIS >

YES >> GO TO 10.

NO >> Repair or replace rear disc brake.

- Refer to [BR-40. "DISC BRAKE ROTOR : Removal and Installation"](#).

10. CHECK ABS ACTUATOR AND ELECTRIC UNIT (CONTROL UNIT) POWER SUPPLY AND GROUND CIRCUIT

Check the ABS actuator and electric unit (control unit) power supply and ground circuit. Refer to [BRC-80. "Diagnosis Procedure"](#).

Is the inspection result normal?

YES >> GO TO 11.

NO >> Repair / replace harness, connector, fuse, or fusible link.

11. CHECK ABS ACTUATOR AND ELECTRIC UNIT (CONTROL UNIT)

ⓑ CONSULT

1. Erase "Self Diagnostic Result" mode of "ABS".

2. Turn the ignition switch OFF.

NOTE:

Wait at least 10 seconds after turning ignition switch OFF.

3. Start the engine.

NOTE:

Wait at least 10 seconds after start the engine.

4. Repeat step 2 to 3 two or more times.

5. Start the engine and drive the vehicle for a short period of time.

NOTE:

Vehicle must be driven after repair or replacement to erase the previous DTCs.

6. Stop the vehicle.

7. Select "Self Diagnostic Result" mode of "ABS".

Is DTC "C1142" detected?

YES >> Replace the ABS actuator and electric unit (control unit). Refer to [BRC-172. "Removal and Installation"](#).

NO >> Check the ABS actuator and electric unit (control unit) harness connector and terminal for damage, looseness and disconnection. Repair / replace harness, connector, or terminal.

C1143 STEERING ANGLE SENSOR

< DTC/CIRCUIT DIAGNOSIS >

[WITHOUT ICC]

C1143 STEERING ANGLE SENSOR

DTC Description

INFOID:000000013444998

DTC DETECTION LOGIC

DTC	Display Item (Trouble diagnosis content)	Malfunction detected condition
C1143	ST ANG SEN CIRCUIT (Steering angle sensor circuit)	When a malfunction is detected in steering angle sensor.

POSSIBLE CAUSE

NOTE:

Confirm if DTC is PAST or CRNT. If DTC is CRNT, proceed with Diagnosis Procedure. If DTC is PAST, clear DTC. Do not replace the ABS actuator and electric unit (control unit) for a PAST DTC.

PAST DTC	CRNT DTC
<ul style="list-style-type: none">• Harness or connector• ABS actuator and electric unit (control unit) power supply system• Fuse• Fusible link• Battery• CAN communication line• Incomplete neutral position adjustment of steering angle sensor• Improper installation of steering angle sensor	<ul style="list-style-type: none">• Harness or connector• Steering angle sensor• ABS actuator and electric unit (control unit)• IPDM E/R• CAN communication line• Wheel alignment• Incomplete neutral position adjustment of steering angle sensor• ABS actuator and electric unit (control unit) power supply system• Fuse• Fusible link• Battery

DTC CONFIRMATION PROCEDURE

1. PRECONDITIONING

If "DTC CONFIRMATION PROCEDURE" has been previously conducted, always turn the ignition switch OFF and wait at least 10 seconds before conducting the next test.

>> GO TO 2.

2. CHECK DTC DETECTION

CONSULT

1. Turn the ignition switch OFF.
NOTE:
Wait at least 10 seconds after turning ignition switch OFF.
2. Start the engine.
NOTE:
Wait at least 10 seconds after start the engine.
3. Repeat step 1 to 2 two or more times.
4. Select "Self Diagnostic Result" mode of "ABS".

Is DTC "C1143" detected?

- YES-1 >> "CRNT" is displayed: Proceed to [BRC-113. "Diagnosis Procedure"](#).
- YES-2 >> "PAST" is displayed: Inspection End (Erase the memory of self-diagnosis results.)
- NO-1 >> To check malfunction symptom before repair: Refer to [GI-42. "Intermittent Incident"](#).
- NO-2 >> Confirmation after repair: Inspection End.

Diagnosis Procedure

INFOID:000000013444999

1. ADJUST THE NEUTRAL POSITION OF STEERING ANGLE SENSOR

CONSULT

Perform neutral position adjustment of steering angle sensor. Refer to [BRC-62. "Description"](#).

C1143 STEERING ANGLE SENSOR

< DTC/CIRCUIT DIAGNOSIS >

[WITHOUT ICC]

>> GO TO 2.

2.PERFORM SELF DIAGNOSTIC RESULT (1)

CONSULT

1. Turn the ignition switch OFF.
NOTE:
Wait at least 10 seconds after turning ignition switch OFF.
2. Start the engine.
NOTE:
Wait at least 10 seconds after start the engine.
3. Repeat step 1 to 2 two or more times.
4. Select "Self Diagnostic Result" mode of "ABS".

Is DTC "C1143" detected?

YES-1 >> "CRNT" is displayed: GO TO 3.

YES-2 >> "PAST" is displayed: Inspection End (Erase the memory of self-diagnosis results.)

NO >> Inspection End.

3.CHECK CONNECTOR

1. Turn the ignition switch OFF.
2. Check the ABS actuator and electric unit (control unit) harness connector for disconnection or looseness.
3. Check the steering angle sensor harness connector for disconnection or looseness.

Is the inspection result normal?

YES >> GO TO 5.

NO >> Repair / replace harness or connector, securely lock the connector, and GO TO 4.

4.PERFORM SELF DIAGNOSTIC RESULT (2)

CONSULT

1. Turn the ignition switch OFF.
NOTE:
Wait at least 10 seconds after turning ignition switch OFF.
2. Start the engine.
NOTE:
Wait at least 10 seconds after start the engine.
3. Repeat step 1 to 2 two or more times.
4. Select "Self Diagnostic Result" mode of "ABS".

Is DTC "C1143" detected?

YES >> GO TO 5.

NO >> Inspection End.

5.CHECK STEERING ANGLE SENSOR POWER SUPPLY

1. Turn the ignition switch OFF.
2. Disconnect steering angle sensor harness connector.
3. Check the voltage between steering angle sensor harness connector and ground.

Steering angle sensor		—	Voltage (Approx.)
Connector	Terminal		
M54	4	Ground	Approx. 0 V

4. Turn the ignition switch ON.
NOTE:
Start the engine.
5. Check the voltage between steering angle sensor harness connector and ground.

C1143 STEERING ANGLE SENSOR

< DTC/CIRCUIT DIAGNOSIS >

[WITHOUT ICC]

Steering angle sensor		—	Voltage (Approx.)
Connector	Terminal		
M54	4	Ground	Battery voltage (Approx.)

Is the inspection result normal?

YES >> GO TO 7.

NO >> GO TO 6.

6.CHECK STEERING ANGLE SENSOR POWER SUPPLY CIRCUIT

1. Turn the ignition switch OFF.
2. Check the 10A fuse (#43).
3. Disconnect IPDM E/R harness connector.
4. Check the continuity between steering angle sensor harness connector and IPDM E/R harness connector.

Steering angle sensor		IPDM E/R		Continuity
Connector	Terminal	Connector	Terminal	
M54	4	E119	35	Yes

5. Check the continuity between steering angle sensor harness connector and ground.

Steering angle sensor		—	Continuity
Connector	Terminal		
M54	4	Ground	No

Is the inspection result normal?

YES >> Perform trouble diagnosis for ignition power supply.

NO >> Repair / replace harness, connector, or fuse.

7.CHECK STEERING ANGLE SENSOR GROUND CIRCUIT

1. Turn the ignition switch OFF.
2. Check the continuity between steering angle sensor harness connector and ground.

Steering angle sensor		—	Continuity
Connector	Terminal		
M54	1	Ground	Yes

Is the inspection result normal?

YES >> GO TO 8.

NO >> Repair / replace harness or connector.

8.CHECK ABS ACTUATOR AND ELECTRIC UNIT (CONTROL UNIT) POWER SUPPLY AND GROUND CIRCUIT

Check the ABS actuator and electric unit (control unit) power supply and ground circuit. Refer to [BRC-80 "Diagnosis Procedure"](#).

Is the inspection result normal?

YES >> GO TO 9.

NO >> Repair / replace harness, connector, fuse, or fusible link.

9.CHECK TERMINAL

1. Check the steering angle sensor pin terminals for damage or loose connection with harness connector.
2. Check the IPDM E/R pin terminals for damage or loose connection with harness connector.

Is the inspection result normal?

YES >> GO TO 10.

NO >> Repair / replace harness, connector, or terminal.

C1143 STEERING ANGLE SENSOR

< DTC/CIRCUIT DIAGNOSIS >

[WITHOUT ICC]

10. CHECK CAN COMMUNICATION LINE

Check the CAN communication line. Refer to [LAN-21, "Trouble Diagnosis Flow Chart"](#).

Is the inspection result normal?

YES >> GO TO 11.

NO >> Repair / replace harness or connector. Refer to [LAN-27, "Precautions for Harness Repair"](#).

11. CHECK DATA MONITOR

CONSULT

1. Select "ABS", "Data Monitor" and "STR ANGLE SIG" in this order.
2. Check that the indication changes with the steering angle when the steering wheel is turned left/right from the neutral position. Refer to [BRC-44, "Reference Value"](#).

Is the inspection result normal?

YES >> Replace the ABS actuator and electric unit (control unit). Refer to [BRC-172, "Removal and Installation"](#).

NO >> Replace the steering angle sensor. Refer to [BRC-175, "Removal and Installation"](#).

C1144 INCOMPLETE STEERING ANGLE SENSOR ADJUSTMENT

< DTC/CIRCUIT DIAGNOSIS >

[WITHOUT ICC]

C1144 INCOMPLETE STEERING ANGLE SENSOR ADJUSTMENT

DTC Description

INFOID:000000013445000

DTC DETECTION LOGIC

DTC	Display Item (Trouble diagnosis content)	Malfunction detected condition
C1144	ST ANG SEN SIGNAL (Steering angle sensor not complete)	When neutral position adjustment of steering angle sensor is not complete.

POSSIBLE CAUSE

NOTE:

Confirm if DTC is PAST or CRNT. If DTC is CRNT, proceed with Diagnosis Procedure. If DTC is PAST, clear DTC. Do not replace the ABS actuator and electric unit (control unit) for a PAST DTC.

PAST DTC	CRNT DTC
Incomplete neutral position adjustment of steering angle sensor	<ul style="list-style-type: none">• Harness or connector• Steering angle sensor• ABS actuator and electric unit (control unit)• Incomplete neutral position adjustment of steering angle sensor

DTC CONFIRMATION PROCEDURE

1. PRECONDITIONING

If "DTC CONFIRMATION PROCEDURE" has been previously conducted, always turn the ignition switch OFF and wait at least 10 seconds before conducting the next test.

>> GO TO 2.

2. CHECK DTC DETECTION

CONSULT

1. Turn the ignition switch OFF.

NOTE:

Wait at least 10 seconds after turning ignition switch OFF.

2. Start the engine.

NOTE:

Wait at least 10 seconds after start the engine.

3. Repeat step 1 to 2 two or more times.
4. Select "Self Diagnostic Result" mode of "ABS".

Is DTC "C1144" detected?

YES-1 >> "CRNT" is displayed: Proceed to [BRC-117, "Diagnosis Procedure"](#).

YES-2 >> "PAST" is displayed: Inspection End (Erase the memory of "Self Diagnostic Result" mode of "ABS".)

NO-1 >> To check malfunction symptom before repair: Refer to [GI-42, "Intermittent Incident"](#).

NO-2 >> Confirmation after repair: Inspection End.

Diagnosis Procedure

INFOID:000000013445001

1. ADJUST THE NEUTRAL POSITION OF STEERING ANGLE SENSOR

Perform neutral position adjustment of steering angle sensor. Refer to [BRC-62, "Description"](#).

>> GO TO 2.

2. CHECK ABS ACTUATOR AND ELECTRIC UNIT (CONTROL UNIT)

CONSULT

1. Turn the ignition switch OFF.

C1144 INCOMPLETE STEERING ANGLE SENSOR ADJUSTMENT

< DTC/CIRCUIT DIAGNOSIS >

[WITHOUT ICC]

NOTE:

Wait at least 10 seconds after turning ignition switch OFF.

2. Start the engine.

NOTE:

Wait at least 10 seconds after start the engine.

3. Repeat step 1 to 2 two or more times.
4. Select "Self Diagnostic Result" mode of "ABS".

Is DTC "C1144" detected?

YES >> GO TO 3.

NO >> Inspection End.

3.CHECK STEERING ANGLE SENSOR SYSTEM

1. Turn the ignition switch OFF.
2. Check the steering angle sensor system. Refer to [BRC-113. "Diagnosis Procedure"](#).

Is the inspection result normal?

YES >> GO TO 4.

NO >> Repair / replace harness, connector, or terminal.

4.CHECK DATA MONITOR

CONSULT

1. "ABS", "Data Monitor" and "STR ANGLE SIG" in this order.
2. Check that the indication changes with the steering angle when the steering wheel is turned left/right from the neutral position. Refer to [BRC-44. "Reference Value"](#).

Is the inspection result normal?

YES >> Replace the ABS actuator and electric unit (control unit). Refer to [BRC-172. "Removal and Installation"](#).

NO >> Replace the steering angle sensor. Refer to [BRC-175. "Removal and Installation"](#).

C1154 TRANSMISSION RANGE SWITCH

< DTC/CIRCUIT DIAGNOSIS >

[WITHOUT ICC]

C1154 TRANSMISSION RANGE SWITCH

DTC Description

INFOID:000000013445002

DTC DETECTION LOGIC

DTC	Display Item (Trouble diagnosis content)	Malfunction detected condition
C1154	PNP POSI SIG (PNP position signal)	When a malfunction is detected in TCM system.

POSSIBLE CAUSE

NOTE:

Confirm if DTC is PAST or CRNT. If DTC is CRNT, proceed with Diagnosis Procedure. If DTC is PAST, clear the DTC. Do not replace the ABS actuator and electric unit (control unit) for a PAST DTC.

PAST DTC	CRNT DTC
<ul style="list-style-type: none">• Harness or connector• Transmission range switch	<ul style="list-style-type: none">• Harness or connector• ABS actuator and electric unit (control unit)• TCM• Transmission range switch

DTC CONFIRMATION PROCEDURE

1. PRECONDITIONING

If "DTC CONFIRMATION PROCEDURE" has been previously conducted, always turn the ignition switch OFF and wait at least 10 seconds before conducting the next test.

>> GO TO 2.

2. CHECK DTC DETECTION

CONSULT

1. Turn the ignition switch OFF.

NOTE:

Wait at least 10 seconds after turning ignition switch OFF.

2. Start the engine.

NOTE:

Wait at least 10 seconds after starting the engine.

3. Select "Self Diagnostic Result" mode of "ABS".

Is DTC "C1154" detected?

YES-1 >> "C1154" is displayed as "CRNT": Proceed to [BRC-119. "Diagnosis Procedure"](#).

YES-2 >> "C1154" is displayed as "PAST": Inspection End (Erase "Self Diagnostic Result" mode of "ABS".)

NO-1 >> To check malfunction symptom before repair: Refer to [GI-42. "Intermittent Incident"](#).

NO-2 >> Confirmation after repair: Inspection End.

Diagnosis Procedure

INFOID:000000013445003

CAUTION:

"C1154" may be detected when going up a slope, being towed with ignition switch ON and the shift selector in a position other than R position. This is not a shift position error. The system returns to normal once the vehicle is stopped, parked on level ground and the engine is started.

1. CHECK CVT SYSTEM

CONSULT

Select "Self Diagnostic Result" mode of "TRANSMISSION".

Is DTC detected?

YES >> Check the DTC. Refer to [TM-58. "DTC Index"](#) (RE0F10J).

NO >> GO TO 2.

C1154 TRANSMISSION RANGE SWITCH

< DTC/CIRCUIT DIAGNOSIS >

[WITHOUT ICC]

2. PERFORM SELF-DIAGNOSIS

CONSULT

1. Erase "Self Diagnostic Result" mode of "ABS".
2. Turn the ignition switch OFF.

NOTE:

Wait at least 10 seconds after turning ignition switch OFF.

3. Start the engine.

NOTE:

Wait at least 10 seconds after starting the engine.

4. Drive the vehicle for a short period of time.

NOTE:

Vehicle must be driven after repair or replacement to erase the previous DTCs.

5. Stop the vehicle.
6. Select "Self Diagnostic Result" mode of "ABS".

Is DTC "C1154" detected?

- YES >> Replace the ABS actuator and electric unit (control unit). Refer to [BRC-172, "Removal and Installation"](#).
- NO >> Check pin terminals and connection of each harness connector for abnormal conditions. Repair / replace harness, connector, or terminal.

C1155 BRAKE FLUID LEVEL SWITCH

< DTC/CIRCUIT DIAGNOSIS >

[WITHOUT ICC]

C1155 BRAKE FLUID LEVEL SWITCH

DTC Description

INFOID:000000013445004

DTC DETECTION LOGIC

DTC	Display Item (Trouble diagnosis content)	Malfunction detected condition
C1155	BR FLUID LEVEL LOW (Brake fluid level low)	<ul style="list-style-type: none">When brake fluid level low signal is detected.When an open circuit is detected in brake fluid level switch circuit.

POSSIBLE CAUSE

NOTE:

Confirm if DTC is PAST or CRNT. If DTC is CRNT, proceed with Diagnosis Procedure. If DTC is PAST, clear DTC. Do not replace the ABS actuator and electric unit (control unit) for a PAST DTC.

PAST DTC	CRNT DTC
<ul style="list-style-type: none">Harness or connectorBrake fluid level is low	<ul style="list-style-type: none">Harness or connectorABS actuator and electric unit (control unit)Brake fluid level switchCombination meterUnified meter and A/C amp.IPDM E/RBrake fluid level is low

DTC CONFIRMATION PROCEDURE

1. PRECONDITIONING

If "DTC CONFIRMATION PROCEDURE" has been previously conducted, always turn the ignition switch OFF and wait at least 10 seconds before conducting the next test.

>> GO TO 2.

2. CHECK DTC DETECTION

CONSULT

- Turn the ignition switch OFF.
NOTE:
Wait at least 10 seconds after turning ignition switch OFF.
- Start the engine.
NOTE:
Wait at least 10 seconds after start the engine.
- Repeat step 1 to 2 two or more times.
- Select "Self Diagnostic Result" mode of "ABS".

Is DTC "C1155" detected?

YES-1 >> "CRNT" is displayed: Proceed to [BRC-121, "Diagnosis Procedure"](#).

YES-2 >> "PAST" is displayed: Inspection End (Erase the memory of "Self Diagnostic Result" mode of "ABS".)

NO-1 >> To check malfunction symptom before repair: Refer to [GI-42, "Intermittent Incident"](#).

NO-2 >> Confirmation after repair: Inspection End.

Diagnosis Procedure

INFOID:000000013445005

1. CHECK BRAKE FLUID LEVEL

- Turn the ignition switch OFF.
- Check the brake fluid level. Refer to [BR-8, "Inspection"](#).

Is the inspection result normal?

YES >> GO TO 3.

NO >> Refill brake fluid. Refer to [BR-14, "Drain and Refill"](#). GO TO 2.

C1155 BRAKE FLUID LEVEL SWITCH

[WITHOUT ICC]

< DTC/CIRCUIT DIAGNOSIS >

2. PERFORM SELF DIAGNOSTIC RESULT (1)

CONSULT

1. Erase "Self Diagnostic Result" mode of "ABS".
2. Turn the ignition switch OFF → ON → OFF.

NOTE:

Wait at least 10 seconds after turning ignition switch OFF or ON.

3. Start the engine.

NOTE:

Wait at least 10 seconds after start the engine.

4. Repeat step 2 to 3 two or more times.
5. Select "Self Diagnostic Result" mode of "ABS".

Is DTC "C1155" detected?

YES >> GO TO 3.

NO >> Inspection End.

3. CHECK CONNECTOR

1. Turn the ignition switch OFF.
2. Check the combination meter harness connector for disconnection or looseness.
3. Check the brake fluid level switch harness connector for disconnection or looseness.

Is the inspection result normal?

YES >> GO TO 5.

NO >> Repair / replace harness or connector, and GO TO 4.

4. PERFORM SELF DIAGNOSTIC RESULT (2)

CONSULT

1. Turn the ignition switch OFF.

NOTE:

Wait at least 10 seconds after turning ignition switch OFF.

2. Start the engine.

NOTE:

Wait at least 10 seconds after start the engine.

3. Repeat step 1 to 2 two or more times.
4. Select "Self Diagnostic Result" mode of "ABS".

Is DTC "C1155" detected?

YES >> GO TO 5.

NO >> Inspection End.

5. CHECK BRAKE FLUID LEVEL SWITCH

Check the brake fluid level switch. Refer to [BR-29, "Exploded View"](#).

Is the inspection result normal?

YES >> GO TO 7.

NO >> Replace the reservoir tank. Refer to [BR-32, "Exploded View"](#). GO TO 6.

6. PERFORM SELF DIAGNOSTIC RESULT (3)

CONSULT

1. Erase "Self Diagnostic Result" mode of "ABS".
2. Turn the ignition switch OFF → ON → OFF.

NOTE:

Wait at least 10 seconds after turning ignition switch OFF or ON.

3. Start the engine.

NOTE:

Wait at least 10 seconds after start the engine.

4. Repeat step 2 to 3 two or more times.
5. Select "Self Diagnostic Result" mode of "ABS".

Is DTC "C1155" detected?

YES >> GO TO 7.

NO >> Inspection End.

C1155 BRAKE FLUID LEVEL SWITCH

< DTC/CIRCUIT DIAGNOSIS >

[WITHOUT ICC]

7. CHECK CONNECTOR AND TERMINAL

1. Turn the ignition switch OFF.
2. Disconnect brake fluid level switch harness connector.
3. Check the brake fluid level switch harness connector for disconnection or looseness.
4. Check the brake fluid level switch pin terminals for damage or loose connection with harness connector.
5. Disconnect combination meter harness connector.
6. Check the combination meter harness connector for disconnection or looseness.
7. Check the combination meter pin terminals for damage or loose connection with harness connector.

Is the inspection result normal?

YES >> GO TO 9.

NO >> Repair / replace harness, connector, or terminal, and GO TO 8.

8. PERFORM SELF DIAGNOSTIC RESULT (4)

CONSULT

1. Erase "Self Diagnostic Result" mode of "ABS".
2. Turn the ignition switch OFF → ON → OFF.
NOTE:
Wait at least 10 seconds after turning ignition switch OFF or ON.
3. Start the engine.
NOTE:
Wait at least 10 seconds after start the engine.
4. Repeat step 2 to 3 two or more times.
5. Select "Self Diagnostic Result" mode of "ABS".

Is DTC "C1155" detected?

YES >> GO TO 9.

NO >> Inspection End.

9. CHECK BRAKE FLUID LEVEL SWITCH CIRCUIT

1. Turn the ignition switch OFF.
2. Disconnect brake fluid level switch harness connector.
3. Disconnect combination meter harness connector.
4. Check the continuity between brake fluid level switch harness connector and combination meter harness connector.

Brake fluid level switch		Combination meter		Continuity
Connector	Terminal	Connector	Terminal	
E21	1	M24	25	Yes

5. Check the continuity between brake fluid level switch harness connector and ground.

Brake fluid level switch		—	Continuity
Connector	Terminal		
E21	1	Ground	No

Is the inspection result normal?

YES >> GO TO 10.

NO >> Repair / replace harness or connector, and GO TO 10.

10. CHECK BRAKE FLUID LEVEL SWITCH GROUND CIRCUIT

Check the continuity between brake fluid level switch harness connector and ground.

Brake fluid level switch		—	Continuity
Connector	Terminal		
E21	2	Ground	Yes

Is the inspection result normal?

YES >> GO TO 11.

C1155 BRAKE FLUID LEVEL SWITCH

[WITHOUT ICC]

< DTC/CIRCUIT DIAGNOSIS >

NO >> Repair / replace harness or connector, and GO TO 11.

11.CHECK COMBINATION METER

Check the combination meter. Refer to [MWI-20, "CONSULT Function \(METER/M&A\)"](#).

Is the inspection result normal?

YES >> Replace the ABS actuator and electric unit (control unit). Refer to [BRC-172, "Removal and Installation"](#).

NO >> Repair or replace combination meter. Refer to [MWI-72, "Removal and Installation"](#).

Component Inspection

INFOID:000000013445006

1.CHECK BRAKE FLUID LEVEL SWITCH

1. Turn the ignition switch OFF.
2. Disconnect brake fluid level switch harness connector.
3. Check the continuity between terminals of brake fluid level switch.

Brake fluid level switch Terminal	Condition	Continuity
1-2	When brake fluid level in reservoir tank is within the specified level.	No
	When brake fluid level in reservoir tank is less than the specified level.	Yes

Is the inspection result normal?

YES >> Inspection End.

NO >> Replace the reservoir tank. Refer to [BR-30, "Disassembly and Assembly"](#).

C1160 INCOMPLETE DECEL G SENSOR CALIBRATION

< DTC/CIRCUIT DIAGNOSIS >

[WITHOUT ICC]

C1160 INCOMPLETE DECEL G SENSOR CALIBRATION

DTC Description

INFOID:000000013445007

DTC DETECTION LOGIC

DTC	Display Item (Trouble diagnosis content)	Malfunction detected condition
C1160	DECEL G SEN SET (Decel G sensor set)	When calibration of yaw rate/side/decel G sensor is not complete.

POSSIBLE CAUSE

NOTE:

Confirm if DTC is PAST or CRNT. If DTC is CRNT, proceed with Diagnosis Procedure. If DTC is PAST, clear DTC. Do not replace the ABS actuator and electric unit (control unit) for a PAST DTC.

PAST DTC	CRNT DTC
<ul style="list-style-type: none"> • Harness or connector • ABS actuator and electric unit (control unit) power supply system • Fuse • Fusible link • Battery 	<ul style="list-style-type: none"> • Incomplete calibration of decel G sensor • ABS actuator and electric unit (control unit)

DTC CONFIRMATION PROCEDURE

1. PRECONDITIONING

If "DTC CONFIRMATION PROCEDURE" has been previously conducted, always turn the ignition switch OFF and wait at least 10 seconds before conducting the next test.

>> GO TO 2.

2. CHECK DTC DETECTION

CONSULT

1. Turn the ignition switch OFF.

NOTE:

Wait at least 10 seconds after turning ignition switch OFF.

2. Start the engine.

NOTE:

Wait at least 10 seconds after start the engine.

3. Repeat step 1 to 2 two or more times.
4. Select "Self Diagnostic" mode of "ABS".

Is DTC "C1160" detected?

YES-1 >> "CRNT" is displayed: Proceed to [BRC-125, "Diagnosis Procedure"](#).

YES-2 >> "PAST" is displayed: Inspection End (Erase the memory of "Self Diagnostic" mode of "ABS".)

NO-1 >> To check malfunction symptom before repair: Refer to [GI-42, "Intermittent Incident"](#).

NO-2 >> Confirmation after repair: Inspection End.

Diagnosis Procedure

INFOID:000000013445008

1. CALIBRATION OF DECEL G SENSOR

Perform calibration of decel G sensor. Refer to [BRC-64, "Work Procedure"](#).

>> GO TO 2.

2. CHECK ABS ACTUATOR AND ELECTRIC UNIT (CONTROL UNIT)

CONSULT

1. Turn the ignition switch OFF.

C1160 INCOMPLETE DECEL G SENSOR CALIBRATION

< DTC/CIRCUIT DIAGNOSIS >

[WITHOUT ICC]

NOTE:

Wait at least 10 seconds after turning ignition switch OFF.

2. Start the engine.

NOTE:

Wait at least 10 seconds after start the engine.

3. Repeat step 1 to 2 two or more times.
4. Select "Self Diagnostic Result" mode of "ABS".

Is DTC "C1160" detected?

- YES >> Replace the ABS actuator and electric unit (control unit). Refer to [BRC-172. "Removal and Installation"](#).
- NO >> Inspection End.

C1164, C1165 CV SYSTEM

DTC Description

INFOID:000000013445009

DTC DETECTION LOGIC

DTC	Display Item (Trouble diagnosis content)	Malfunction detected condition
C1164	CV 1 (Cut valve 1)	When a malfunction is detected in cut valve 1.
C1165	CV 2 (Cut valve 2)	When a malfunction is detected in cut valve 2.

POSSIBLE CAUSE

NOTE:

Confirm if DTC is PAST or CRNT. If DTC is CRNT, proceed with Diagnosis Procedure. If DTC is PAST, clear DTC. Do not replace the ABS actuator and electric unit (control unit) for a PAST DTC.

PAST DTC	CRNT DTC
<ul style="list-style-type: none"> • Harness or connector • ABS actuator and electric unit (control unit) power supply system • Fuse • Fusible link • Battery 	<ul style="list-style-type: none"> • Harness or connector • ABS actuator and electric unit (control unit) • ABS actuator and electric unit (control unit) power supply system • Fuse • Fusible link • Battery

DTC CONFIRMATION PROCEDURE

1. PRECONDITIONING

If "DTC CONFIRMATION PROCEDURE" has been previously conducted, always turn the ignition switch OFF and wait at least 10 seconds before conducting the next test.

>> GO TO 2.

2. CHECK DTC DETECTION

 CONSULT

- Turn the ignition switch OFF.
NOTE:
Wait at least 10 seconds after turning ignition switch OFF.
- Start the engine.
NOTE:
Wait at least 10 seconds after start the engine.
- Repeat step 1 to 2 two or more times.
- Select "Self Diagnostic Result" mode of "ABS".

Is DTC "C1164" or "C1165" detected?

- YES-1 >> "C1164" or "C1165" is displayed by "CRNT": Proceed to [BRC-127, "Diagnosis Procedure"](#).
- YES-2 >> "C1164" and "C1165" are displayed by "PAST": Inspection End (Erase the memory of "Self Diagnostic Result" mode of "ABS".)
- NO-1 >> To check malfunction symptom before repair: Refer to [GI-42, "Intermittent Incident"](#).
- NO-2 >> Confirmation after repair: Inspection End.

Diagnosis Procedure

INFOID:000000013445010

1. CHECK CONNECTOR

- Turn the ignition switch OFF.
- Check the ABS actuator and electric unit (control unit) harness connector for disconnection or looseness.

Is the inspection result normal?

A
B
C
D
E
BRC
G
H
I
J
K
L
M
N
O
P

C1164, C1165 CV SYSTEM

[WITHOUT ICC]

< DTC/CIRCUIT DIAGNOSIS >

YES >> GO TO 3.

NO >> Repair / replace harness or connector, securely lock the connector, and GO TO 2.

2.PERFORM SELF-DIAGNOSIS

ⓂCONSULT

Select "Self Diagnostic Result" mode of "ABS" again.

Is DTC "C1164" or "C1165" detected?

YES >> GO TO 3.

NO >> Inspection End.

3.CHECK ABS ACTUATOR AND ELECTRIC UNIT (CONTROL UNIT) POWER SUPPLY AND GROUND CIRCUIT

Check the ABS actuator and electric unit (control unit) power supply and ground circuit. Refer to [BRC-80. "Diagnosis Procedure"](#).

Is the inspection result normal?

YES >> GO TO 4.

NO >> Repair / replace harness, connector, fuse, or fusible link.

4.CHECK TERMINAL

Check the ABS actuator and electric unit (control unit) pin terminals for damage or loose connection with harness.

Is the inspection result normal?

YES >> Replace the ABS actuator and electric unit (control unit). Refer to [BRC-172. "Removal and Installation"](#).

NO >> Repair / replace harness, connector, or terminal.

C1166, C1167 SV SYSTEM

DTC Description

INFOID:000000013445011

DTC DETECTION LOGIC

DTC	Display Item (Trouble diagnosis content)	Malfunction detected condition
C1166	SV 1 (Suction valve 1)	When a malfunction is detected in suction valve 1.
C1167	SV 2 (Suction valve 2)	When a malfunction is detected in suction valve 2.

POSSIBLE CAUSE

NOTE:

Confirm if DTC is PAST or CRNT. If DTC is CRNT, proceed with Diagnosis Procedure. If DTC is PAST, clear DTC. Do not replace the ABS actuator and electric unit (control unit) for a PAST DTC.

PAST DTC	CRNT DTC
<ul style="list-style-type: none"> • Harness or connector • ABS actuator and electric unit (control unit) power supply system • Fuse • Fusible link • Battery 	<ul style="list-style-type: none"> • Harness or connector • ABS actuator and electric unit (control unit) • ABS actuator and electric unit (control unit) power supply system • Fuse • Fusible link • Battery

DTC CONFIRMATION PROCEDURE

1. PRECONDITIONING

If "DTC CONFIRMATION PROCEDURE" has been previously conducted, always turn the ignition switch OFF and wait at least 10 seconds before conducting the next test.

>> GO TO 2.

2. CHECK DTC DETECTION

 CONSULT

1. Turn the ignition switch OFF.
NOTE:
Wait at least 10 seconds after turning ignition switch OFF.
2. Start the engine.
NOTE:
Wait at least 10 seconds after start the engine.
3. Repeat step 1 to 2 two or more times.
4. Select "Self Diagnostic Result" mode of "ABS".

Is DTC "C1166" or "C1167" detected?

- YES-1 >> "C1166" or "C1167" is displayed by "CRNT": Proceed to [BRC-129, "Diagnosis Procedure"](#).
- YES-2 >> "C1166" and "C1167" is displayed by "PAST": Inspection End. (Erase the memory of "Self Diagnostic Result" mode of "ABS".)
- NO-1 >> To check malfunction symptom before repair: Refer to [GI-42, "Intermittent Incident"](#).
- NO-2 >> Confirmation after repair: Inspection End.

Diagnosis Procedure

INFOID:000000013445012

1. CHECK CONNECTOR

1. Turn the ignition switch OFF.
 2. Check the ABS actuator and electric unit (control unit) harness connector for disconnection or looseness.
- Is the inspection result normal?

C1166, C1167 SV SYSTEM

[WITHOUT ICC]

< DTC/CIRCUIT DIAGNOSIS >

YES >> GO TO 3.

NO >> Repair / replace harness or connector, securely lock the connector, and GO TO 2.

2.PERFORM SELF DIAGNOSTIC RESULT

ⓂCONSULT

Select "Self Diagnostic Result" mode of "ABS" again.

Is DTC "C1166" or "C1167" detected?

YES >> GO TO 3.

NO >> Inspection End.

3.CHECK ABS ACTUATOR AND ELECTRIC UNIT (CONTROL UNIT) POWER SUPPLY AND GROUND CIRCUIT

Check the ABS actuator and electric unit (control unit) power supply and ground circuit. Refer to [BRC-80. "Diagnosis Procedure"](#).

Is the inspection result normal?

YES >> GO TO 4.

NO >> Repair / replace harness, connector, fuse, or fusible link.

4.CHECK TERMINAL

Check the ABS actuator and electric unit (control unit) pin terminals for damage or loose connection with harness.

Is the inspection result normal?

YES >> Replace the ABS actuator and electric unit (control unit). Refer to [BRC-172. "Removal and Installation"](#).

NO >> Repair / replace harness, connector, or terminal.

C1170 VARIANT CODING

< DTC/CIRCUIT DIAGNOSIS >

[WITHOUT ICC]

C1170 VARIANT CODING

DTC Description

INFOID:000000013445013

DTC DETECTION LOGIC

DTC	Display Item (Trouble diagnosis content)	Malfunction detected condition
C1170	VARIANT CODING (Variant coding)	When the information in ABS actuator and electric unit (control unit) is not the same.

POSSIBLE CAUSE

NOTE:

Confirm if DTC is PAST or CRNT. If DTC is CRNT, proceed with Diagnosis Procedure. If DTC is PAST, clear DTC. Do not replace the ABS actuator and electric unit (control unit) for a PAST DTC.

PAST DTC	CRNT DTC
—	<ul style="list-style-type: none"> • ABS actuator and electric unit (control unit) • ABS actuator and electric unit (control unit) is not configured.

DTC CONFIRMATION PROCEDURE

1. PRECONDITIONING

If "DTC CONFIRMATION PROCEDURE" has been previously conducted, always turn the ignition switch OFF and wait at least 10 seconds before conducting the next test.

>> GO TO 2.

2. CHECK DTC DETECTION

CONSULT

1. Turn the ignition switch OFF.

NOTE:

Wait at least 10 seconds after turning ignition switch OFF.

2. Start the engine.

NOTE:

Wait at least 10 seconds after start the engine.

3. Select "Self Diagnostic Result" mode of "ABS".

Is DTC "C1170" detected?

YES-1 >> "CRNT" is displayed: Proceed to [BRC-131, "Diagnosis Procedure"](#).

YES-2 >> "PAST" is displayed: Inspection End (Erase the memory of self-diagnosis results.)

NO-1 >> To check malfunction symptom before repair: Refer to [GI-42, "Intermittent Incident"](#).

NO-2 >> Confirmation after repair: Inspection End.

Diagnosis Procedure

INFOID:000000013445014

1. CONFIGURATION OF ABS ACTUATOR AND ELECTRIC UNIT (CONTROL UNIT)

Perform configuration of ABS actuator and electric unit (control unit). Refer to [BRC-66, "Work Procedure"](#).

CAUTION:

Never replace the ABS actuator and electric unit (control unit).

>> GO TO 2.

2. CHECK SELF-DIAGNOSIS RESULTS

CONSULT

Replace the ABS actuator and electric unit (control unit) even if other DTC are displayed along with "C1170" in self-diagnosis for "ABS".

C1170 VARIANT CODING

< DTC/CIRCUIT DIAGNOSIS >

[WITHOUT ICC]

>> Replace the ABS actuator and electric unit (control unit). Refer to [BRC-172. "Removal and Installation"](#).

C1197 VACUUM SENSOR

< DTC/CIRCUIT DIAGNOSIS >

[WITHOUT ICC]

C1197 VACUUM SENSOR

DTC Description

INFOID:000000013445015

DTC DETECTION LOGIC

DTC	Display Item (Trouble diagnosis content)	Malfunction detected condition
C1197	VACUUM SENSOR (Vacuum sensor)	When a malfunction is detected in vacuum sensor.

POSSIBLE CAUSE

NOTE:

Confirm if DTC is PAST or CRNT. If DTC is CRNT, proceed with Diagnosis Procedure. If DTC is PAST, clear DTC. Do not replace the ABS actuator and electric unit (control unit) for a PAST DTC.

PAST DTC	CRNT DTC
<ul style="list-style-type: none"> • Harness or connector • ABS actuator and electric unit (control unit) power supply system • Fuse • Fusible link • Battery 	<ul style="list-style-type: none"> • Harness or connector • Vacuum sensor (brake booster) • Vacuum piping • ABS actuator and electric unit (control unit)

DTC CONFIRMATION PROCEDURE

1. PRECONDITIONING

If "DTC CONFIRMATION PROCEDURE" has been previously conducted, always turn the ignition switch OFF and wait at least 10 seconds before conducting the next test.

>> GO TO 2.

2. CHECK DTC DETECTION

CONSULT

- Turn the ignition switch OFF.
NOTE:
Wait at least 10 seconds after turning ignition switch OFF.
- Start the engine.
NOTE:
Wait at least 10 seconds after start the engine.
- Select "Self Diagnostic Result" mode of "ABS".

Is DTC "C1197" detected?

- YES-1 >> "CRNT" is displayed: Proceed to [BRC-133, "Diagnosis Procedure"](#).
 YES-2 >> "PAST" is displayed: Inspection End (Erase the memory of self-diagnosis results.)
 NO-1 >> To check malfunction symptom before repair: Refer to [Gl-42, "Intermittent Incident"](#).
 NO-2 >> Confirmation after repair: Inspection End.

Diagnosis Procedure

INFOID:000000013445016

1. CHECK CONNECTOR

- Turn the ignition switch OFF.
- Check the vacuum sensor harness connector for disconnection or looseness.
- Check the ABS actuator and electric unit (control unit) harness connector for disconnection or looseness.

Is the inspection result normal?

- YES >> GO TO 2.
 NO >> Repair / replace harness or connector, and GO TO 2.

2. CHECK BRAKE BOOSTER

- Turn the ignition switch OFF.

C1197 VACUUM SENSOR

[WITHOUT ICC]

< DTC/CIRCUIT DIAGNOSIS >

2. Check the brake booster. Refer to [BR-10, "Inspection"](#).

Is the inspection result normal?

YES >> GO TO 3.

NO >> Replace the brake booster. Refer to [BR-32, "Removal and Installation"](#).

3. CHECK VACUUM PIPING

Check the vacuum piping. Refer to [BR-34, "Exploded View"](#).

Is the inspection result normal?

YES >> GO TO 4.

NO >> Replace the vacuum piping. Refer to [BR-34, "Removal and Installation"](#).

4. CHECK TERMINAL

1. Turn the ignition switch OFF.
2. Disconnect vacuum sensor harness connector.
3. Check the vacuum sensor pin terminals for damage or loose connection with harness connector.
4. Disconnect ABS actuator and electric unit (control unit) harness connector.
5. Check the ABS actuator and electric unit (control unit) pin terminals for damage or loose connection with harness connector.

Is the inspection result normal?

YES >> GO TO 5.

NO >> Repair / replace harness, connector, or terminal.

5. CHECK VACUUM SENSOR CIRCUIT

1. Turn the ignition switch OFF.
2. Disconnect vacuum sensor harness connector.
3. Disconnect ABS actuator and electric unit (control unit) harness connector.
4. Check the continuity between vacuum sensor harness connector and ABS actuator and electric unit (control unit) harness connector.

Vacuum sensor		ABS actuator and electric unit (control unit)		Continuity
Connector	Terminal	Connector	Terminal	
E167	1	E125	12	Yes
	2		24	
	3		5	

5. Check the continuity between vacuum sensor harness connector and ground.

Vacuum sensor		—	Continuity
Connector	Terminal		
E167	1	Ground	No
	2		
	3		

Is the inspection result normal?

YES >> GO TO 6.

NO >> Repair / replace harness or connector.

6. REPLACE VACUUM SENSOR

Ⓜ CONSULT

1. Connect ABS actuator and electric unit (control unit) harness connector.
2. Replace the vacuum sensor.

CAUTION:

Always replace brake booster because vacuum sensor cannot be disassembled. Refer to [BR-32, "Removal and Installation"](#).

3. Erase "Self Diagnostic Result" mode of "ABS".
4. Turn the ignition switch OFF → ON → OFF.

NOTE:

C1197 VACUUM SENSOR

< DTC/CIRCUIT DIAGNOSIS >

[WITHOUT ICC]

Wait at least 10 seconds after turning ignition switch OFF or ON.

5. Start engine.

NOTE:

Wait at least 10 seconds after start the engine.

6. Select "Self Diagnostic Result" mode of "ABS".

Is DTC "C1197" detected?

YES >> Replace the ABS actuator and electric unit (control unit). Refer to [BRC-172, "Removal and Installation"](#).

NO >> Inspection End.

A
B
C
D
E
G
H
I
J
K
L
M
N
O
P

BRC

C1198 VACUUM SENSOR

< DTC/CIRCUIT DIAGNOSIS >

[WITHOUT ICC]

C1198 VACUUM SENSOR

DTC Description

INFOID:000000013445017

DTC DETECTION LOGIC

DTC	Display Item (Trouble diagnosis content)	Malfunction detected condition
C1198	VACUUM SEN CIR (Vacuum sensor circuit)	<ul style="list-style-type: none">• When an open circuit is detected in vacuum sensor circuit.• When a short circuit is detected in vacuum sensor circuit.• When a malfunction is detected in vacuum sensor noise.

POSSIBLE CAUSE

NOTE:

Confirm if DTC is PAST or CRNT. If DTC is CRNT, proceed with Diagnosis Procedure. If DTC is PAST, clear DTC. Do not replace the ABS actuator and electric unit (control unit) for a PAST DTC.

PAST DTC	CRNT DTC
<ul style="list-style-type: none">• Harness or connector• ABS actuator and electric unit (control unit) power supply system• Fuse• Fusible link• Battery	<ul style="list-style-type: none">• Harness or connector• Vacuum sensor (brake booster)• ABS actuator and electric unit (control unit)

DTC CONFIRMATION PROCEDURE

1. PRECONDITIONING

If "DTC CONFIRMATION PROCEDURE" has been previously conducted, always turn the ignition switch OFF and wait at least 10 seconds before conducting the next test.

>> GO TO 2.

2. CHECK DTC DETECTION

CONSULT

1. Turn the ignition switch OFF.
NOTE:
Wait at least 10 seconds after turning ignition switch OFF.
2. Start the engine.
NOTE:
Wait at least 10 seconds after start the engine.
3. Select "Self Diagnostic Result" mode of "ABS".

Is DTC "C1198" detected?

- YES-1 >> "CRNT" is displayed: Proceed to [BRC-136, "Diagnosis Procedure"](#).
YES-2 >> "PAST" is displayed: Inspection End (Erase the memory of self-diagnosis results.)
NO-1 >> To check malfunction symptom before repair: Refer to [GI-42, "Intermittent Incident"](#).
NO-2 >> Confirmation after repair: Inspection End.

Diagnosis Procedure

INFOID:000000013445018

1. CHECK CONNECTOR

1. Turn the ignition switch OFF.
2. Check the vacuum sensor harness connector for disconnection or looseness.
3. Check the ABS actuator and electric unit (control unit) harness connector for disconnection or looseness.

Is the inspection result normal?

- YES >> GO TO 2.
NO >> Repair / replace harness or connector, and GO TO 2.

2. CHECK TERMINAL

C1198 VACUUM SENSOR

[WITHOUT ICC]

< DTC/CIRCUIT DIAGNOSIS >

1. Turn the ignition switch OFF.
2. Disconnect vacuum sensor harness connector.
3. Check the vacuum sensor pin terminals for damage or loose connection with harness connector.
4. Disconnect ABS actuator and electric unit (control unit) harness connector.
5. Check the ABS actuator and electric unit (control unit) pin terminals for damage or loose connection with harness connector.

Is the inspection result normal?

YES >> GO TO 3.

NO >> Repair / replace harness, connector, or terminal.

3. CHECK VACUUM SENSOR CIRCUIT

1. Turn the ignition switch OFF.
2. Disconnect vacuum sensor harness connector.
3. Disconnect ABS actuator and electric unit (control unit) harness connector.
4. Check the continuity between vacuum sensor harness connector and ABS actuator and electric unit (control unit) harness connector.

Vacuum sensor		ABS actuator and electric unit (control unit)		Continuity
Connector	Terminal	Connector	Terminal	
E167	1	E125	12	Yes
	2		24	
	3		5	

5. Check the continuity between vacuum sensor harness connector and ground.

Vacuum sensor		—	Continuity
Connector	Terminal		
E167	1	Ground	No
	2		
	3		

Is the inspection result normal?

YES >> GO TO 4.

NO >> Repair / replace harness or connector.

4. REPLACE VACUUM SENSOR

Ⓜ CONSULT

1. Connect ABS actuator and electric unit (control unit) harness connector.
2. Replace the vacuum sensor.

CAUTION:

Always replace brake booster because vacuum sensor cannot be disassembled. Refer to [BR-32, "Removal and Installation"](#).

3. Erase "Self Diagnostic Result" mode of "ABS".
4. Turn the ignition switch OFF → ON → OFF.

NOTE:

Wait at least 10 seconds after turning ignition switch OFF or ON.

5. Start engine.

NOTE:

Wait at least 10 seconds after start the engine.

6. Select "Self Diagnostic Result" mode of "ABS".

Is DTC "C1198" detected?

YES >> Replace the ABS actuator and electric unit (control unit). Refer to [BRC-172, "Removal and Installation"](#).

NO >> Inspection End.

C1199 BRAKE BOOSTER

< DTC/CIRCUIT DIAGNOSIS >

[WITHOUT ICC]

C1199 BRAKE BOOSTER

DTC Description

INFOID:000000013445019

DTC DETECTION LOGIC

DTC	Display Item (Trouble diagnosis content)	Malfunction detected condition
C1199	BRAKE BOOSTER (Brake booster)	When brake booster vacuum is approx. 0 kPa (0 mmHg) during engine running.

POSSIBLE CAUSE

NOTE:

Confirm if DTC is PAST or CRNT. If DTC is CRNT, proceed with Diagnosis Procedure. If DTC is PAST, clear DTC. Do not replace the ABS actuator and electric unit (control unit) for a PAST DTC.

PAST DTC	CRNT DTC
<ul style="list-style-type: none">• Harness or connector• ABS actuator and electric unit (control unit) power supply system• Fuse• Fusible link• Battery	<ul style="list-style-type: none">• Harness or connector• Vacuum sensor (brake booster)• Vacuum piping• ABS actuator and electric unit (control unit)

DTC CONFIRMATION PROCEDURE

1. PRECONDITIONING

If "DTC CONFIRMATION PROCEDURE" has been previously conducted, always turn the ignition switch OFF and wait at least 10 seconds before conducting the next test.

>> GO TO 2.

2. CHECK DTC DETECTION

CONSULT

1. Turn the ignition switch OFF.

NOTE:

Wait at least 10 seconds after turning ignition switch OFF.

2. Start the engine.

NOTE:

Wait at least 10 seconds after start the engine.

3. Select "Self Diagnostic Result" mode of "ABS".

Is DTC "C1199" detected?

YES-1 >> "CRNT" is displayed: Proceed to [BRC-138, "Diagnosis Procedure"](#).

YES-2 >> "PAST" is displayed: Inspection End (Erase the memory of self-diagnosis results.)

NO-1 >> To check malfunction symptom before repair: Refer to [GI-42, "Intermittent Incident"](#).

NO-2 >> Confirmation after repair: Inspection End.

Diagnosis Procedure

INFOID:000000013445020

1. CHECK CONNECTOR

1. Turn the ignition switch OFF.
2. Check the vacuum sensor harness connector for disconnection or looseness.
3. Check the ABS actuator and electric unit (control unit) harness connector for disconnection or looseness.

Is the inspection result normal?

YES >> GO TO 2.

NO >> Repair / replace harness or connector, and GO TO 2.

2. CHECK BRAKE BOOSTER

C1199 BRAKE BOOSTER

[WITHOUT ICC]

< DTC/CIRCUIT DIAGNOSIS >

1. Turn the ignition switch OFF.
2. Check the brake booster. Refer to [BR-10, "Inspection"](#).

Is the inspection result normal?

YES >> GO TO 3.

NO >> Replace the brake booster. Refer to [BR-32, "Removal and Installation"](#).

3.CHECK VACUUM PIPING

Check the vacuum piping. Refer to [BR-34, "Exploded View"](#).

Is the inspection result normal?

YES >> GO TO 4.

NO >> Replace the vacuum piping. Refer to [BR-34, "Removal and Installation"](#).

4.CHECK TERMINAL

1. Turn the ignition switch OFF.
2. Disconnect vacuum sensor harness connector.
3. Check the vacuum sensor pin terminals for damage or loose connection with harness connector.
4. Disconnect ABS actuator and electric unit (control unit) harness connector.
5. Check the ABS actuator and electric unit (control unit) pin terminals for damage or loose connection with harness connector.

Is the inspection result normal?

YES >> GO TO 5.

NO >> Repair / replace harness, connector, or terminal.

5.CHECK VACUUM SENSOR CIRCUIT

1. Turn the ignition switch OFF.
2. Disconnect vacuum sensor harness connector.
3. Disconnect ABS actuator and electric unit (control unit) harness connector.
4. Check the continuity between vacuum sensor harness connector and ABS actuator and electric unit (control unit) harness connector.

Vacuum sensor		ABS actuator and electric unit (control unit)		Continuity
Connector	Terminal	Connector	Terminal	
E167	1	E125	12	Yes
	2		24	
	3		5	

5. Check the continuity between vacuum sensor harness connector and ground.

Vacuum sensor		—	Continuity
Connector	Terminal		
E167	1	Ground	No
	2		
	3		

Is the inspection result normal?

YES >> GO TO 6.

NO >> Repair / replace harness or connector.

6.REPLACE VACUUM SENSOR

ⓂCONSULT

1. Connect ABS actuator and electric unit (control unit) harness connector.
2. Replace the vacuum sensor.

CAUTION:

Always replace brake booster because vacuum sensor cannot be disassembled. Refer to [BR-32, "Removal and Installation"](#).

3. Erase "Self Diagnostic Result" mode of "ABS".
4. Turn the ignition switch OFF → ON → OFF.

C1199 BRAKE BOOSTER

< DTC/CIRCUIT DIAGNOSIS >

[WITHOUT ICC]

NOTE:

Wait at least 10 seconds after turning ignition switch OFF or ON.

5. Start engine.

NOTE:

Wait at least 10 seconds after start the engine.

6. Select "Self Diagnostic Result" mode of "ABS".

Is DTC "C1199" detected?

YES >> Replace the ABS actuator and electric unit (control unit). Refer to [BRC-172, "Removal and Installation"](#).

NO >> Inspection End.

C119A VACUUM SENSOR

< DTC/CIRCUIT DIAGNOSIS >

[WITHOUT ICC]

C119A VACUUM SENSOR

DTC Description

INFOID:000000013445021

DTC DETECTION LOGIC

DTC	Display Item (Trouble diagnosis content)	Malfunction detected condition
C119A	VACUUM SEN VOLT (Vacuum sensor voltage)	When a malfunction is detected in supply power voltage of vacuum sensor.

POSSIBLE CAUSE

NOTE:

Confirm if DTC is PAST or CRNT. If DTC is CRNT, proceed with Diagnosis Procedure. If DTC is PAST, clear DTC. Do not replace the ABS actuator and electric unit (control unit) for a PAST DTC.

PAST DTC	CRNT DTC
<ul style="list-style-type: none"> • Harness or connector • ABS actuator and electric unit (control unit) power supply system • Fuse • Fusible link • Battery 	<ul style="list-style-type: none"> • Harness or connector • Vacuum sensor (brake booster) • ABS actuator and electric unit (control unit) • ABS actuator and electric unit (control unit) power supply system • Fuse • Fusible link • Battery

DTC CONFIRMATION PROCEDURE

1. PRECONDITIONING

If "DTC CONFIRMATION PROCEDURE" has been previously conducted, always turn the ignition switch OFF and wait at least 10 seconds before conducting the next test.

>> GO TO 2.

2. CHECK DTC DETECTION

CONSULT

1. Turn the ignition switch OFF.

NOTE:

Wait at least 10 seconds after turning ignition switch OFF.

2. Start the engine.

NOTE:

Wait at least 10 seconds after start the engine.

3. Select "Self Diagnostic Result" mode of "ABS".

Is DTC "C119A" detected?

YES-1 >> "CRNT" is displayed: Proceed to [BRC-141, "Diagnosis Procedure"](#).

YES-2 >> "PAST" is displayed: Inspection End (Erase the memory of self-diagnosis results.)

NO-1 >> To check malfunction symptom before repair: Refer to [GI-42, "Intermittent Incident"](#).

NO-2 >> Confirmation after repair: Inspection End.

Diagnosis Procedure

INFOID:000000013445022

1. CHECK CONNECTOR

1. Turn the ignition switch OFF.
2. Check the vacuum sensor harness connector for disconnection or looseness.
3. Check the ABS actuator and electric unit (control unit) harness connector for disconnection or looseness.

Is the inspection result normal?

YES >> GO TO 2.

NO >> Repair / replace harness or connector, and GO TO 2.

C119A VACUUM SENSOR

[WITHOUT ICC]

< DTC/CIRCUIT DIAGNOSIS >

2. CHECK VACUUM SENSOR POWER SUPPLY

1. Turn the ignition switch OFF.
2. Disconnect vacuum sensor harness connector.
3. Check the voltage between vacuum sensor harness connector and ground.

+		-	Voltage (Approx.)
Vacuum sensor			
Connector	Terminal		
E167	3	Ground	0 V

4. Turn the ignition switch ON.

NOTE:

Start the engine.

5. Check the voltage between vacuum sensor harness connector and ground.

+		-	Voltage (Approx.)
Vacuum sensor			
Connector	Terminal		
E167	3	Ground	Battery voltage

Is the inspection result normal?

YES >> GO TO 4.

NO >> GO TO 3.

3. CHECK VACUUM SENSOR POWER SUPPLY CIRCUIT

1. Turn the ignition switch OFF.
2. Disconnect ABS actuator and electric unit (control unit) harness connector.
3. Check the continuity between vacuum sensor harness connector and ABS actuator and electric unit (control unit) harness connector.

Vacuum sensor		ABS actuator and electric unit (control unit)		Continuity
Connector	Terminal	Connector	Terminal	
E167	3	E125	5	Yes

4. Check the continuity between vacuum sensor harness connector and ground.

Vacuum sensor		—	Continuity
Connector	Terminal		
E167	3	Ground	No

Is the inspection result normal?

YES >> GO TO 4.

NO >> Repair / replace harness or connector.

4. CHECK VACUUM SENSOR GROUND CIRCUIT

1. Turn the ignition switch OFF.
2. Check the continuity between vacuum sensor harness connector and ground.

Vacuum sensor		—	Continuity
Connector	Terminal		
E167	3	Ground	No

Is the inspection result normal?

YES >> GO TO 5.

NO >> Repair / replace harness or connector.

C119A VACUUM SENSOR

< DTC/CIRCUIT DIAGNOSIS >

[WITHOUT ICC]

5. CHECK ABS ACTUATOR AND ELECTRIC UNIT (CONTROL UNIT) POWER SUPPLY AND GROUND CIRCUIT

Check the ABS actuator and electric unit (control unit) power supply and ground circuit. Refer to [BRC-80. "Diagnosis Procedure"](#).

Is the inspection result normal?

YES >> GO TO 6.

NO >> Repair / replace harness, connector, fuse, or fusible link.

6. CHECK TERMINAL

1. Check the vacuum sensor pin terminals for damage or loose connection with harness connector.

2. Check the ABS actuator and electric unit (control unit) pin terminals for damage or loose connection with harness connector.

Is the inspection result normal?

YES >> Replace the ABS actuator and electric unit (control unit). Refer to [BRC-172. "Removal and Installation"](#).

NO >> Repair / replace harness, connector, or terminal.

A
B
C
D
E
G
H
I
J
K
L
M
N
O
P

BRC

U1000 CAN COMM CIRCUIT

< DTC/CIRCUIT DIAGNOSIS >

[WITHOUT ICC]

U1000 CAN COMM CIRCUIT

DTC Description

INFOID:000000013445023

DTC DETECTION LOGIC

DTC	Display Item (Trouble diagnosis content)	Malfunction detected condition
U1000	CAN COMM CIRCUIT (CAN communication circuit)	When CAN communication signal is not continuously transmitted or received for 2 seconds or more.

POSSIBLE CAUSE

NOTE:

Confirm if DTC is PAST or CRNT. If DTC is CRNT, proceed with Diagnosis Procedure. If DTC is PAST, clear DTC. Do not replace the ABS actuator and electric unit (control unit) for a PAST DTC.

PAST DTC	CRNT DTC
<ul style="list-style-type: none">• Harness or connector• CAN communication line	CAN communication system malfunction

DTC CONFIRMATION PROCEDURE

1. PRECONDITIONING

If "DTC CONFIRMATION PROCEDURE" has been previously conducted, always turn the ignition switch OFF and wait at least 10 seconds before conducting the next test.

>> GO TO 2.

2. CHECK DTC DETECTION

CONSULT

1. Turn the ignition switch OFF.

NOTE:

Wait at least 10 seconds after turning ignition switch OFF.

2. Start the engine.

NOTE:

Wait at least 10 seconds after start the engine.

3. Repeat step 1 to 2 two or more times.
4. Select "Self Diagnostic Result" mode of "ABS".

Is DTC "U1000" detected?

YES-1 >> "CRNT" is displayed: Proceed to [BRC-144, "Diagnosis Procedure"](#).

YES-2 >> "PAST" is displayed: Inspection End (Erase the memory of "Self Diagnostic Result" mode of "ABS".)

NO-1 >> To check malfunction symptom before repair: Refer to [GI-42, "Intermittent Incident"](#).

NO-2 >> Confirmation after repair: Inspection End.

Diagnosis Procedure

INFOID:000000013445024

Proceed to [LAN-21, "Trouble Diagnosis Flow Chart"](#).

U1002 SYSTEM COMM (CAN)

< DTC/CIRCUIT DIAGNOSIS >

[WITHOUT ICC]

U1002 SYSTEM COMM (CAN)

DTC Description

INFOID:000000012894468

DTC DETECTION LOGIC

DTC	Display item (Trouble diagnosis content)	Malfunction detected condition
U1002	SYSTEM COMM (CAN) (CAN system communication)	When ABS actuator and electric unit (control unit) is not transmitting or receiving CAN communication signal for 2 seconds or less.

POSSIBLE CAUSE

NOTE:

Confirm if DTC is PAST or CRNT. If DTC is CRNT, proceed with Diagnosis Procedure. If DTC is PAST, clear the DTC. Do not replace the ABS actuator and electric unit (control unit) for a PAST DTC.

PAST DTC	CRNT DTC
<ul style="list-style-type: none"> CAN communication line Harness or connector 	<ul style="list-style-type: none"> CAN communication line ABS actuator and electric unit (control unit) Steering angle sensor

DTC CONFIRMATION PROCEDURE

1. PRECONDITIONING

If "DTC CONFIRMATION PROCEDURE" has been previously conducted, always turn the ignition switch OFF and wait at least 10 seconds before conducting the next test.

>> GO TO 2.

2. DTC REPRODUCTION PROCEDURE

CONSULT

1. Turn the ignition switch OFF.

NOTE:

Wait at least 10 seconds after turning ignition switch OFF.

2. Start the engine.

NOTE:

Wait at least 10 seconds after starting the engine.

3. Perform "Self Diagnostic Result" of "ABS".

Is DTC "U1002" detected?

YES-1 >> "CRNT" is displayed: Proceed to [BRC-145. "Diagnosis Procedure"](#).

YES-2 >> "PAST" is displayed: Inspection End (Erase "Self Diagnostic Result" of "ABS").

NO-1 >> To check malfunction symptom before repair: Refer to [GI-42. "Intermittent Incident"](#).

NO-2 >> Confirmation after repair: Inspection End.

Diagnosis Procedure

INFOID:000000012894469

CAUTION:

- Never apply 7.0 V or more to the measurement terminal.
- Use a tester with open terminal voltage of 7.0 V or less.
- Turn the ignition switch OFF and disconnect the battery cable from the negative terminal when checking the harness.

1. CHECK CAN DIAGNOSIS SUPPORT MONITOR

CONSULT

1. Perform "CAN Diagnosis Support Monitor" of "ABS".

2. Check the malfunction history between each control unit connected to ABS actuator and electric unit (control unit).

Check the result of "PAST"?

U1002 SYSTEM COMM (CAN)

< DTC/CIRCUIT DIAGNOSIS >

[WITHOUT ICC]

All items are "OK">>Check the intermittent incident. Refer to [GI-42. "Intermittent Incident"](#).

"TRANSMIT DIAG" is other than "OK">>GO TO 2.

A control unit other than ABS actuator and electric unit (control unit) is anything other than "OK">>GO TO 3.

2.CHECK TRANSMITTING SIDE UNIT

Check the ABS actuator and electric unit (control unit) harness connector terminals No. 14 and 26 for damage or loose connection.

Is the inspection result normal?

YES >> Erase "Self Diagnostic Result" mode of "ABS". Then select "Self Diagnostic Result" of "ABS" using CONSULT.

NO >> Recheck the terminals for damage or loose connection.

3.CHECK APPLICABLE CONTROL UNIT

Check the terminals of each harness connector for damage or loose connection.

Is the inspection result normal?

YES >> Erase "Self Diagnostic Result" mode of applicable control unit. Then perform "Self Diagnostic Result" of applicable control unit using CONSULT.

NO >> Recheck the terminals for damage or loose connection.

POWER SUPPLY AND GROUND CIRCUIT

< DTC/CIRCUIT DIAGNOSIS >

[WITHOUT ICC]

POWER SUPPLY AND GROUND CIRCUIT

Diagnosis Procedure

INFOID:000000012894470

1. CHECK ABS ACTUATOR AND ELECTRIC UNIT (CONTROL UNIT) IGNITION POWER SUPPLY (1)

1. Turn the ignition switch OFF.
2. Disconnect ABS actuator and electric unit (control unit) harness connector.
3. Check the voltage between ABS actuator and electric unit (control unit) harness connector and ground.

ABS actuator and electric unit (control unit)		—	Voltage (Approx.)
Connector	Terminal		
E125	28	Ground	0 V

4. Turn the ignition switch ON
NOTE:
Start the engine.
5. Check the voltage between ABS actuator and electric unit (control unit) harness connector and ground.

ABS actuator and electric unit (control unit)		—	Voltage (Approx.)
Connector	Terminal		
E125	28	Ground	Battery voltage

Is the inspection result normal?

- YES >> GO TO 3.
NO >> GO TO 2.

2. CHECK ABS ACTUATOR AND ELECTRIC UNIT (CONTROL UNIT) IGNITION POWER SUPPLY CIRCUIT

1. Turn the ignition switch OFF.
2. Check the 10A fuse (46).
3. Disconnect IPDM E/R harness connector.
4. Check the continuity between ABS actuator and electric unit (control unit) harness connector and IPDM E/R.

ABS actuator and electric unit (control unit)		IPDM E/R		Continuity
Connector	Terminal	Connector	Terminal	
E125	28	E119	35	Yes

5. Check the continuity between ABS actuator and electric unit (control unit) harness connector and ground.

ABS actuator and electric unit (control unit)		—	Continuity
Connector	Terminal		
E125	28	Ground	No

Is the inspection result normal?

- YES >> Perform trouble diagnosis for ignition power supply.
NO >> Repair / replace harness, connector, or fuse.

3. CHECK MOTOR AND MOTOR RELAY POWER SUPPLY

1. Turn the ignition switch OFF.
2. Check the voltage between ABS actuator and electric unit (control unit) harness connector and ground.

ABS actuator and electric unit (control unit)		—	Voltage (Approx.)
Connector	Terminal		
E125	1	Ground	Battery voltage

3. Turn the ignition switch ON.
NOTE:

POWER SUPPLY AND GROUND CIRCUIT

< DTC/CIRCUIT DIAGNOSIS >

[WITHOUT ICC]

Start the engine.

4. Check the voltage between ABS actuator and electric unit (control unit) harness connector and ground.

ABS actuator and electric unit (control unit)		—	Voltage (Approx.)
Connector	Terminal		
E125	1	Ground	Battery voltage

Is the inspection result normal?

YES >> GO TO 5.

NO >> GO TO 4.

4.CHECK MOTOR AND MOTOR RELAY POWER SUPPLY CIRCUIT

1. Turn the ignition switch OFF.
2. Check the 40A fusible link (G).
3. Check the continuity and short circuit between ABS actuator and electric unit (control unit) harness connector terminal 1 and 40A fusible link (G).

Is the inspection result normal?

YES >> Perform trouble diagnosis for battery power supply.

NO >> Repair / replace harness, connector, or fusible link.

5.CHECK ACTUATOR RELAY, ABS IN VALVE, ABS OUT VALVE POWER SUPPLY

1. Turn the ignition switch OFF.
2. Check the voltage between ABS actuator and electric unit (control unit) harness connector and ground.

ABS actuator and electric unit (control unit)		—	Voltage (Approx.)
Connector	Terminal		
E125	25	Ground	Battery voltage

3. Turn the ignition switch ON

NOTE:

Start the engine.

4. Check the voltage between ABS actuator and electric unit (control unit) harness connector and ground.

ABS actuator and electric unit (control unit)		—	Voltage (Approx.)
Connector	Terminal		
E125	25	Ground	Battery voltage

Is the inspection result normal?

YES >> GO TO 7.

NO >> GO TO 6.

6.CHECK ACTUATOR RELAY, ABS IN VALVE, ABS OUT VALVE POWER SUPPLY CIRCUIT

1. Turn the ignition switch OFF.
2. Check the 30A fusible link (I).
3. Check the continuity and short circuit between ABS actuator and electric unit (control unit) harness connector terminal 25 and 30A fusible link (I).

Is the inspection result normal?

YES >> Perform trouble diagnosis for battery power supply.

NO >> Repair / replace harness, connector, or fusible link.

7.CHECK ABS ACTUATOR AND ELECTRIC UNIT (CONTROL UNIT) GROUND CIRCUIT

Check the continuity between ABS actuator and electric unit (control unit) harness connector and the ground.

POWER SUPPLY AND GROUND CIRCUIT

< DTC/CIRCUIT DIAGNOSIS >

[WITHOUT ICC]

ABS actuator and electric unit (control unit)		—	Continuity
Connector	Terminal		
E125	13	Ground	Yes
	38		

Is the inspection result normal?

YES >> GO TO 8.

NO >> Repair / replace harness, connector, or terminal.

8. CHECK TERMINAL

1. Check the ABS actuator and electric unit (control unit) pin terminals for damage or loose connection with harness connector.
2. Check the IPDM E/R pin terminals for damage or loose connection with harness connector.

Is the inspection result normal?

YES >> Replace the ABS actuator and electric unit (control unit). Refer to [BRC-172, "Removal and Installation"](#).

NO >> Repair / replace harness, connector, or terminal.

A
B
C
D
E
G
H
I
J
K
L
M
N
O
P

BRC

PARKING BRAKE SWITCH

< DTC/CIRCUIT DIAGNOSIS >

[WITHOUT ICC]

PARKING BRAKE SWITCH

Component Function Check

INFOID:000000012894471

1.CHECK PARKING BRAKE SWITCH OPERATION

Check that brake warning lamp in combination meter turns ON/OFF when parking brake is operated.

Is the inspection result normal?

- YES >> Inspection End.
- NO >> Proceed to [BRC-150, "Diagnosis Procedure"](#).

Diagnosis Procedure

INFOID:000000012894472

1.CHECK PARKING BRAKE SWITCH CIRCUIT

1. Turn the ignition switch OFF.
2. Disconnect parking brake switch harness connector.
3. Disconnect combination meter harness connector.
4. Check the continuity between parking brake switch harness connector and combination meter harness connector.

Parking brake switch		Combination meter		Continuity
Connector	Terminal	Connector	Terminal	
E52	1	M24	26	Yes

5. Check the continuity between parking brake switch harness connector and ground.

Parking brake switch		—	Continuity
Connector	Terminal		
E52	1	Ground	No

Is the inspection result normal?

- YES >> GO TO 2.
- NO >> Repair or replace error-detected parts.

2.CHECK PARKING BRAKE SWITCH

Check the parking brake switch. Refer to [PB-4, "Inspection and Adjustment"](#).

Is the inspection result normal?

- YES >> GO TO 3.
- NO >> Replace the parking brake switch. Refer to [PB-10, "Removal and Installation"](#).

3.CHECK PARKING BRAKE SWITCH SIGNAL

CONSULT

1. Select "Data Monitor"
2. Select "PARK BRAKE SW".
3. Check that the function operates normally according to the following conditions:

Condition	Data Monitor
Operate parking brake	On
Release parking brake	Off

Is the inspection result normal?

- YES >> Inspection End.
- NO >> GO TO 4.

4.CHECK COMBINATION METER

Check the combination meter. Refer to [MWI-20, "CONSULT Function \(METER/M&A\)"](#).

Is the inspection result normal?

PARKING BRAKE SWITCH

< DTC/CIRCUIT DIAGNOSIS >

[WITHOUT ICC]

YES >> GO TO 5.

NO >> Repair or replace combination meter. Refer to [MWI-72, "Removal and Installation"](#).

5.CHECK TERMINAL

1. Check the combination meter pin terminals for damage or loose connection with harness connector.
2. Check the parking brake switch pin terminals for damage or loose connection with harness connector.

Is the inspection result normal?

YES >> Replace the ABS actuator and electric unit (control unit). Refer to [BRC-172, "Removal and Installation"](#).

NO >> Repair or replace error-detected parts.

Component Inspection

INFOID:000000012894473

1.CHECK PARKING BRAKE SWITCH

1. Turn the ignition switch OFF.
2. Disconnect parking brake switch harness connector.
3. Check the continuity between parking brake switch terminal and ground.

Parking brake switch Terminal	—	Condition	Continuity
1	Ground	When parking brake switch is pressed	Yes
		When parking brake switch is released	No

Is the inspection result normal?

YES >> Inspection End.

NO >> Replace the parking brake switch. Refer to [PB-10, "Removal and Installation"](#).

VDC OFF SWITCH

< DTC/CIRCUIT DIAGNOSIS >

[WITHOUT ICC]

VDC OFF SWITCH

Component Function Check

INFOID:000000012894474

1.CHECK VDC OFF SWITCH OPERATION

Check that VDC OFF indicator lamp in combination meter turns ON/OFF when VDC OFF switch is operated.

Is the inspection result normal?

YES >> Inspection End.

NO >> Proceed to [BRC-152, "Diagnosis Procedure"](#).

Diagnosis Procedure

INFOID:000000012894475

1.CHECK VDC OFF SWITCH CIRCUIT

1. Turn the ignition switch OFF.
2. Disconnect ABS actuator and electric unit (control unit) harness connector.
3. Disconnect VDC OFF switch harness connector.
4. Check the continuity between ABS actuator and electric unit (control unit) harness connector and VDC OFF switch harness connector.

Without Intelligent Cruise Control

ABS actuator and electric unit (control unit)		VDC OFF switch		Continuity
Connector	Terminal	Connector	Terminal	
E125	15	M71	6	Yes

5. Check the continuity between ABS actuator and electric unit (control unit) harness connector and ground.

ABS actuator and electric unit (control unit)		—	Continuity
Connector	Terminal		
E125	15	Ground	No

Is the inspection result normal?

YES >> GO TO 2.

NO >> Repair or replace error-detected parts.

2.CHECK VDC OFF SWITCH GROUND CIRCUIT

Check the continuity between VDC OFF switch harness connector and ground.

VDC OFF switch		—	Continuity
Connector	Terminal		
M71	8	Ground	Yes

Is the inspection result normal?

YES >> GO TO 3.

NO >> Repair or replace error-detected parts.

3.CHECK VDC OFF SWITCH

Check the VDC OFF switch. Refer to [BRC-153, "Component Inspection"](#).

Is the inspection result normal?

YES >> GO TO 4.

NO >> Replace the VDC OFF switch. Refer to [BRC-174, "Removal and Installation"](#).

4.CHECK VDC OFF SWITCH SIGNAL

CONSULT

1. Select "Data Monitor" mode of "ABS".
2. Select "OFF SW".
3. Check that the function operates normally according to the following conditions:

VDC OFF SWITCH

< DTC/CIRCUIT DIAGNOSIS >

[WITHOUT ICC]

Condition	Data Monitor
When VDC OFF switch is pressed and VDC OFF indicator lamp in combination meter is in ON status	On
When VDC OFF switch is pressed and VDC OFF indicator lamp in combination meter is in OFF status	Off

Is the inspection result normal?

- YES >> Inspection End.
 NO >> GO TO 5.

5.CHECK TERMINAL

1. Check the ABS actuator and electric unit (control unit) pin terminals for damage or loose connection with harness connector.
2. Check the VDC OFF switch pin terminals for damage or loose connection with harness connector.

Is the inspection result normal?

- YES >> Replace the ABS actuator and electric unit (control unit). Refer to [BRC-172. "Removal and Installation"](#).
 NO >> Repair or replace error-detected parts.

Component Inspection

INFOID:0000000012894476

1.CHECK VDC OFF SWITCH

1. Turn the ignition switch OFF.
2. Disconnect VDC OFF switch harness connector.
3. Check the continuity between terminals of VDC OFF switch connector.

VDC OFF switch	Condition	Continuity
Terminal		
6-8	When VDC OFF switch is pressed	Yes
	When VDC OFF switch is not pressed	No

Is the inspection result normal?

- YES >> Inspection End.
 NO >> Replace the VDC OFF switch. Refer to [BRC-174. "Removal and Installation"](#).

A
B
C
D
E
G
H
I
J
K
L
M
N
O
P

BRC

ABS WARNING LAMP

Component Function Check

INFOID:000000012894477

1. CHECK ABS WARNING LAMP FUNCTION

Check that ABS warning lamp in combination meter turns ON for 1 second after ignition switch is turned ON.

CAUTION:

Never start the engine.

Is the inspection result normal?

- YES >> Inspection End.
- NO >> Proceed to [BRC-154, "Diagnosis Procedure"](#).

Diagnosis Procedure

INFOID:000000012894478

1. CHECK ABS ACTUATOR AND ELECTRIC UNIT (CONTROL UNIT) POWER SUPPLY AND GROUND CIRCUIT

Perform the trouble diagnosis for ABS actuator and electric unit (control unit) power supply and ground circuit. Refer to [BRC-154, "Diagnosis Procedure"](#).

Is the inspection result normal?

- YES >> GO TO 2.
- NO >> Repair or replace error-detected parts.

2. PERFORM SELF DIAGNOSTIC RESULT

 CONSULT

1. Turn the ignition switch OFF → ON.

CAUTION:

- **Be sure to wait 10 seconds after turning ignition switch OFF or ON.**
- **Start the engine.**

2. Repeat step 1 two or more times.
3. Perform "Self Diagnostic Result" for "ABS".

Is any DTC detected?

- YES >> Check the DTC. Refer to [BRC-51, "DTC Index"](#).
- NO >> GO TO 3.

3. CHECK ABS WARNING LAMP SIGNAL

 CONSULT

1. Select "ABS", "Data Monitor" and "ABS WARN LAMP" in this order.
2. Turn the ignition switch OFF.
3. Check that data monitor displays "On" for 1 second after ignition switch is turned ON and then changes to "Off".

CAUTION:

Never start the engine.

Is the inspection result normal?

- YES >> Replace the combination meter. Refer to [MWI-72, "Removal and Installation"](#).
- NO >> Replace the ABS actuator and electric unit (control unit). Refer to [BRC-172, "Removal and Installation"](#).

BRAKE WARNING LAMP

Component Function Check

INFOID:000000012894479

1. CHECK BRAKE WARNING LAMP FUNCTION

Check that brake warning lamp in combination meter turns ON for 1 second after ignition switch is turned ON.

CAUTION:

Never start the engine.

Is the inspection result normal?

YES >> GO TO 2.

NO >> Proceed to [BRC-155. "Diagnosis Procedure"](#).

2. CHECK BRAKE WARNING LAMP FUNCTION

Check that brake warning lamp turns ON/OFF when parking brake is operated.

NOTE:

Brake warning lamp turns ON when parking brake is operated (when parking brake switch is ON).

Is the inspection result normal?

YES >> GO TO 3.

NO >> Check the parking brake switch system. Refer to [BRC-150. "Diagnosis Procedure"](#).

3. CHECK BRAKE WARNING LAMP FUNCTION

Check that brake warning lamp in combination meter turns ON/OFF when brake fluid level switch is operated while brake fluid level in reservoir tank is within the specified level.

NOTE:

Brake warning lamp turns ON when brake fluid is less than the specified level (when brake fluid level switch is ON).

Is the inspection result normal?

YES >> Inspection End.

NO >> Check the brake fluid level switch system. Refer to [BR-29. "Exploded View"](#).

Diagnosis Procedure

INFOID:000000012894480

1. CHECK ABS ACTUATOR AND ELECTRIC UNIT (CONTROL UNIT) POWER SUPPLY AND GROUND CIRCUIT

Perform the trouble diagnosis for ABS actuator and electric unit (control unit) power supply and ground circuits. Refer to [BRC-147. "Diagnosis Procedure"](#).

Is the inspection result normal?

YES >> GO TO 2.

NO >> Repair or replace error-detected parts.

2. PERFORM THE SELF DIAGNOSTIC RESULT

ⓂCONSULT

1. Turn the ignition switch OFF → ON.

CAUTION:

- Be sure to wait 10 seconds after turning ignition switch OFF or ON.
- Start the engine.

2. Repeat step 1 two or more times.

3. Select "Self Diagnostic Result" mode of "ABS".

Is any DTC detected?

YES >> Check the DTC. Refer to [BRC-51. "DTC Index"](#).

NO >> GO TO 3.

3. CHECK BRAKE WARNING LAMP SIGNAL

ⓂCONSULT

1. Select "ABS", "Data Monitor" mode and "EBD WARN LAMP" in this order.

2. Turn the ignition switch OFF.

A
B
C
D
E
G
H
I
J
K
L
M
N
O
P

BRC

BRAKE WARNING LAMP

< DTC/CIRCUIT DIAGNOSIS >

[WITHOUT ICC]

3. Check that data monitor displays "On" for 1 second after ignition switch is turned ON and then changes to "Off".

CAUTION:

Never start the engine.

Is the inspection result normal?

- YES >> Replace the combination meter. Refer to [MWI-72. "Removal and Installation"](#).
- NO >> Replace the ABS actuator and electric unit (control unit). Refer to [BRC-172. "Removal and Installation"](#).

< DTC/CIRCUIT DIAGNOSIS >

VDC WARNING LAMP

Component Function Check

INFOID:0000000012894481

1. CHECK VDC WARNING LAMP FUNCTION

Check that VDC warning lamp in combination meter turns ON for 1 second after ignition switch is turned ON.

CAUTION:**Never start the engine.**

Is the inspection result normal?

YES >> Inspection End.

NO >> Proceed to [BRC-157, "Diagnosis Procedure"](#).

Diagnosis Procedure

INFOID:0000000012894482

1. CHECK ABS ACTUATOR AND ELECTRIC UNIT (CONTROL UNIT) POWER SUPPLY AND GROUND CIRCUIT

Perform the trouble diagnosis for ABS actuator and electric unit (control unit) power supply and ground circuits. Refer to [BRC-147, "Diagnosis Procedure"](#).

Is the inspection result normal?

YES >> GO TO 2.

NO >> Repair or replace error-detected parts.

2. PERFORM THE SELF DIAGNOSTIC RESULT

CONSULT

1. Turn the ignition switch OFF → ON.

CAUTION:

- Be sure to wait 10 seconds after turning ignition switch OFF or ON.
- Start the engine.

2. Repeat step 1 two or more times.

3. Select "Self Diagnostic Result" mode of "ABS".

Is any DTC detected?

YES >> Check the DTC. Refer to [BRC-51, "DTC Index"](#).

NO >> GO TO 3.

3. CHECK VDC WARNING LAMP SIGNAL

CONSULT

1. Select "ABS", "Data Monitor" mode and "SLIP/VDC LAMP" in this order.

2. Turn the ignition switch OFF.

3. Check that data monitor displays "On" for approximately 1 second after ignition switch is turned ON and then changes to "Off".

CAUTION:**Never start the engine.**

Is the inspection result normal?

YES >> Replace the combination meter. Refer to [MWI-72, "Removal and Installation"](#).NO >> Replace the ABS actuator and electric unit (control unit). Refer to [BRC-172, "Removal and Installation"](#).

VDC OFF INDICATOR LAMP

Component Function Check

INFOID:000000012894483

1.CHECK VDC OFF INDICATOR LAMP FUNCTION (1)

Check that VDC OFF indicator lamp in combination meter turns ON for 1 second after ignition switch is turned ON.

CAUTION:

Never start the engine.

Is the inspection result normal?

YES >> GO TO 2.

NO >> Proceed to [BRC-158, "Diagnosis Procedure"](#).

2.CHECK VDC OFF INDICATOR LAMP FUNCTION (2)

Check that VDC OFF indicator lamp in combination meter turns ON/OFF when VDC OFF switch is operated.

Is the inspection result normal?

YES >> Inspection End.

NO >> Check the VDC OFF switch system. Refer to [BRC-152, "Diagnosis Procedure"](#).

Diagnosis Procedure

INFOID:000000012894484

1.CHECK ABS ACTUATOR AND ELECTRIC UNIT (CONTROL UNIT) POWER SUPPLY AND GROUND CIRCUIT

Perform the trouble diagnosis for ABS actuator and electric unit (control unit) power supply and ground circuits. Refer to [BRC-147, "Diagnosis Procedure"](#).

Is the inspection result normal?

YES >> GO TO 2.

NO >> Repair or replace error-detected parts.

2.CHECK VDC OFF INDICATOR LAMP SIGNAL

ⓐCONSULT

1. Select "ABS", "Data Monitor" mode and "OFF LAMP" in this order.
2. Turn the ignition switch OFF.
3. Check that data monitor displays "On" for 1 second after ignition switch is turned ON and then changes to "Off".

CAUTION:

Never start the engine.

Is the inspection result normal?

YES >> GO TO 3.

NO >> Replace the ABS actuator and electric unit (control unit). Refer to [BRC-172, "Removal and Installation"](#).

3.CHECK VDC OFF INDICATOR LAMP SIGNAL

ⓐCONSULT

1. Select "ABS", "Data Monitor" mode and "OFF LAMP" in this order.
2. Check that data monitor displays "On" or "Off" each time VDC OFF switch is operated.

Is the inspection result normal?

YES >> Replace the combination meter. Refer to [MWI-72, "Removal and Installation"](#).

NO >> Check the VDC OFF switch system. Refer to [BRC-152, "Diagnosis Procedure"](#).

EXCESSIVE OPERATION FREQUENCY

< SYMPTOM DIAGNOSIS >

[WITHOUT ICC]

SYMPTOM DIAGNOSIS

EXCESSIVE OPERATION FREQUENCY

Description

INFOID:0000000012894485

VDC function, TCS function, ABS function, EBD function, brake assist function or hill start assist function operates in excessive operation frequency.

Diagnosis Procedure

INFOID:0000000012894486

1. CHECK BRAKING FORCE

Check brake force using a brake tester.

Is the inspection result normal?

YES >> GO TO 2.

NO >> Check brake system.

2. CHECK FRONT AND REAR AXLE

Check that there is no excessive looseness in front and rear axle.

2WD: Refer to [FAX-6, "Inspection"](#) (front) or [RAX-6, "Inspection"](#) (rear).

Is the inspection result normal?

YES >> GO TO 3.

NO >> Repair or replace error-detected parts.

3. CHECK WHEEL SENSOR

Check wheel sensor.

- Check installation and damage of wheel sensor.
- Check connection of wheel sensor harness connector.
- Check terminal of wheel sensor harness connector.

Is the inspection result normal?

YES >> GO TO 4.

NO >> Repair installation or replace wheel sensor.

• Front wheel sensor: Refer to [BRC-167, "FRONT WHEEL SENSOR : Removal and Installation"](#).

• Rear wheel sensor: Refer to [BRC-169, "REAR WHEEL SENSOR : Removal and Installation"](#).

4. CHECK SENSOR ROTOR

Check that there is no looseness, damage or foreign material on sensor rotor.

Is the inspection result normal?

YES >> GO TO 5.

NO >> Repair installation or replace sensor rotor.

• Front sensor rotor: Refer to [BRC-171, "FRONT SENSOR ROTOR : Removal and Installation - Front Sensor Rotor"](#).

• Rear sensor rotor: Refer to [BRC-171, "REAR SENSOR ROTOR : Removal and Installation - Rear Sensor Rotor"](#).

5. CHECK THAT WARNING LAMP TURNS OFF

Check that ABS warning lamp, brake warning lamp and VDC warning lamp turn OFF approximately 1 second after key switch is turned ON and stay in OFF status during driving.

CAUTION:

Brake warning lamp turns ON when parking brake is operated (parking brake switch is ON) or brake fluid is less than the specified level (brake fluid level switch is ON).

Is the inspection result normal?

YES >> Normal

NO >> GO TO 6.

6. PERFORM THE SELF DIAGNOSTIC RESULT

CONSULT

1. Turn the ignition switch OFF → ON.

A
B
C
D
E
BRC
G
H
I
J
K
L
M
N
O
P

EXCESSIVE OPERATION FREQUENCY

< SYMPTOM DIAGNOSIS >

[WITHOUT ICC]

CAUTION:

- Be sure to wait 10 seconds after turning ignition switch OFF or ON.
- Set the vehicle to READY/Start the engine.

2. Repeat step 1 two or more times.
3. Select "Self Diagnostic Result" mode of "ABS".

Is any DTC detected?

- YES >> Check the DTC. Refer to [BRC-51, "DTC Index"](#).
- NO >> Inspection End.

UNEXPECTED BRAKE PEDAL REACTION

< SYMPTOM DIAGNOSIS >

[WITHOUT ICC]

UNEXPECTED BRAKE PEDAL REACTION

Description

INFOID:000000012894487

A malfunction of brake pedal feel (height or other) is detected when brake pedal is depressed.

Diagnosis Procedure

INFOID:000000012894488

1.CHECK FRONT AND REAR AXLE

Check that there is no excessive looseness in front and rear axle.
Refer to [FAX-6. "Inspection"](#) (front) or [RAX-6. "Inspection"](#) (rear).

Is the inspection result normal?

YES >> GO TO 2.

NO >> Repair or replace error-detected parts.

2.CHECK DISC ROTOR

Check disc rotor runout.

• Front: Refer to [BR-11. "DISC BRAKE ROTOR : Inspection"](#).

• Rear: Refer to [BR-12. "DISC BRAKE ROTOR : Inspection"](#).

Is the inspection result normal?

YES >> GO TO 3.

NO >> Refinish the disc rotor.

3.CHECK BRAKE FLUID LEAKAGE

Check fluid leakage.

Refer to [BR-8. "Inspection"](#).

Is the inspection result normal?

YES >> GO TO 4.

NO >> Repair or replace error-detected parts.

4.CHECK BRAKE PEDAL

Check each item of brake pedal. Refer to [BR-7. "Inspection"](#).

Is the inspection result normal?

YES >> GO TO 5.

NO >> Adjust each item of brake pedal. Refer to [BR-13. "Adjustment"](#).

5.CHECK BRAKING FORCE

Check brake force using a brake tester.

Is the inspection result normal?

YES >> GO TO 6.

NO >> Check each component of brake system.

6.CHECK BRAKE PERFORMANCE

Disconnect ABS actuator and electric unit (control unit) connector so that ABS does not operate. Check that brake force is normal in this condition. Connect harness connectors after checking.

Is the inspection result normal?

YES >> Normal

NO >> Check each component of brake system.

A
B
C
D
E
BRC
G
H
I
J
K
L
M
N
O
P

THE BRAKING DISTANCE IS LONG

< SYMPTOM DIAGNOSIS >

[WITHOUT ICC]

THE BRAKING DISTANCE IS LONG

Description

INFOID:000000012894489

Brake stopping distance is long when ABS function is operated.

Diagnosis Procedure

INFOID:000000012894490

CAUTION:

Brake stopping distance on a slippery road like a rough road, gravel road or snowy road may become longer when ABS is operated than when ABS is not operated.

1.CHECK BRAKING FORCE

Check brake force using a brake tester.

Is the inspection result normal?

YES >> GO TO 2.

NO >> Check each component of brake system.

2.CHECK BRAKE PERFORMANCE

Disconnect ABS actuator and electric unit (control unit) connector so that ABS does not operate. Check brake stopping distance in this condition. Connect harness connectors after checking.

Is the inspection result normal?

YES >> Normal

NO >> Check each component of brake system.

DOES NOT OPERATE

< SYMPTOM DIAGNOSIS >

[WITHOUT ICC]

DOES NOT OPERATE

Description

INFOID:000000012894491

VDC function, TCS function, ABS function, EBD function, brake assist function or hill start assist function does not operate.

Diagnosis Procedure

INFOID:000000012894492

CAUTION:

- VDC function, TCS function, ABS function, EBD function, brake assist function and hill start assist function never operate when the vehicle speed is 10 km/h (6.2 MPH) or less. However, TCS function, and hill start assist function operate when the vehicle speed is 0 km/h (0 MPH) (the vehicle is in stop status).
- VDC function and TCS function never operate when VDC OFF switch is operated (when VDC OFF indicator lamp turns ON).

1. CHECK ABS WARNING LAMP

Check that ABS warning lamp, brake warning lamp and VDC warning lamp turn ON and turn OFF approximately 1 second after key switch is turned ON. Check that ABS warning lamp, brake warning lamp and VDC warning lamp stay in OFF status during driving.

CAUTION:

Brake warning lamp turns ON when parking brake is operated (parking brake switch is ON) or brake fluid is less than the specified level (brake fluid level switch is ON).

Is the inspection result normal?

- YES >> Normal
NO >> GO TO 2.

2. PERFORM SELF DIAGNOSTIC RESULT

CONSULT

1. Turn the ignition switch OFF → ON.

CAUTION:

- Be sure to wait 10 seconds after turning ignition switch OFF or ON.
- Start the engine.

2. Repeat step 1 two or more times.
3. Select "Self Diagnostic Result" mode of "ABS".

Is any DTC detected?

- YES >> Check the DTC. Refer to [BRC-51, "DTC Index"](#).
NO >> Inspection End.

A
B
C
D
E
BRC
G
H
I
J
K
L
M
N
O
P

BRAKE PEDAL VIBRATION OR OPERATION SOUND OCCURS

< SYMPTOM DIAGNOSIS >

[WITHOUT ICC]

BRAKE PEDAL VIBRATION OR OPERATION SOUND OCCURS

Description

INFOID:000000012894493

- Brake pedal vibrates and motor sound from ABS actuator and electric unit (control unit) occurs when the engine starts.
- Brake pedal vibrates during braking.

CAUTION:

Vibration may be felt when brake pedal is lightly depressed (just placing a foot on it) in the following conditions. This is normal.

- When shifting gears
- When driving on slippery road
- During cornering at high speeds
- When passing over bumps or grooves [Approx. 50 mm (1.97 in) or more]
- When pulling away just after starting engine [at approx. 10 km/h (6.2 MPH) or higher]

Diagnosis Procedure

INFOID:000000012894494

1. SYMPTOM CHECK 1

Check that there are pedal vibrations when the engine is started.

Do vibrations occur?

- YES >> GO TO 2.
- NO >> Check brake pedal. Refer to [BR-13. "Adjustment"](#).

2. SYMPTOM CHECK 2

Check that motor sound from ABS actuator and electric unit occurs when the engine starts.

Does the operation sound occur?

- YES >> GO TO 3.
- NO >> Select "Self Diagnostic Result" mode of "ABS" with CONSULT.

3. SYMPTOM CHECK 3

Check symptoms when electrical component (headlamps, etc.) switches are operated.

Does the symptom occur?

- YES >> Check that radio (including wiring), antenna and antenna lead-in wires are not located near ABS actuator and electric unit (control unit). Move them if they are located near ABS actuator and electric unit (control unit).
- NO >> GO TO 4.

4. PERFORM SELF DIAGNOSTIC RESULT

CONSULT

1. Turn the ignition switch OFF → ON.

CAUTION:

- Be sure to wait 10 seconds after turning ignition switch OFF or ON.
 - Start the engine.
2. Repeat step 1 two or more times.
 3. Select "Self Diagnostic Result" mode of "ABS".

Is any DTC detected?

- YES >> Check the DTC. Refer to [BRC-51. "DTC Index"](#).
- NO >> Inspection End.

VEHICLE JERKS DURING

Description

INFOID:000000012894495

The vehicle jerks when VDC function, TCS function, ABS function, EBD function, brake assist function or hill start assist function operates.

Diagnosis Procedure

INFOID:000000012894496

1. CHECK SYMPTOM

Check that the vehicle jerks when VDC function, TCS function, ABS function, EBD function, brake assist function or hill start assist function operates.

Is the inspection result normal?

- YES >> Normal
- NO >> GO TO 2.

2. PERFORM THE SELF DIAGNOSTIC RESULT

CONSULT

1. Turn the ignition switch OFF → ON.

CAUTION:

- Be sure to wait 10 seconds after turning ignition switch OFF or ON.
- Start the engine.

2. Repeat step 1 two or more times.
3. Select "Self Diagnostic Result" mode of "ABS".

Is any DTC detected?

- YES >> Check the DTC. Refer to [BRC-51, "DTC Index"](#).
- NO >> GO TO 3.

3. CHECK CONNECTOR

1. Turn the ignition switch OFF.
2. Disconnect ABS actuator and electric unit (control unit) harness connector.
3. Check connector terminal for deformation, disconnection and looseness.

Is the inspection result normal?

- YES >> GO TO 4.
- NO >> Poor connection of connector terminal. Repair or replace connector terminal.

4. PERFORM THE SELF DIAGNOSTIC RESULT

CONSULT

1. Connect harness connector.
 2. Turn the ignition switch OFF → ON.
- CAUTION:**
- Be sure to wait 10 seconds after turning ignition switch OFF or ON.
 - Start the engine.
3. Repeat step 2 two or more times.
 4. Select "Self Diagnostic Result" mode of "ABS".

Is any DTC detected?

- YES >> Check the DTC. Refer to [BRC-51, "DTC Index"](#).
- NO >> GO TO 5.

5. PERFORM THE SELF DIAGNOSTIC RESULT

CONSULT

Select "Self Diagnostic Result" mode of "ENGINE" and "TRANSMISSION".

Is any DTC detected?

- YES >> Check the DTC.
- NO >> Replace ABS actuator and electric unit (control unit). Refer to [BRC-172, "Removal and Installation"](#).

NORMAL OPERATING CONDITION

< SYMPTOM DIAGNOSIS >

[WITHOUT ICC]

NORMAL OPERATING CONDITION

Description

INFOID:000000012894497

Symptom	Result
Brake pedal slightly vibrates and operation sound (motor sound and sound from suspension) occurs when VDC function, TCS function, ABS function, EBD function, brake assist function, hill start assist function operates.	This is not a malfunction, because it is caused by VDC function, TCS function, ABS function, EBD function, brake assist function, hill start assist function that are normally operated.
Brake stopping distance may become longer than models without ABS function depending on the road conditions when ABS function is operated on a slippery road, rough road, gravel road or snowy road.	
Brake pedal vibrates and operation sound occurs during sudden acceleration and cornering when VDC function, TCS function, brake assist function or brake force distribution function is operated.	
Brake pedal vibrates and motor sound from the engine room occurs when the engine starts or the vehicle starts just after starting the engine.	This is not a malfunction, because it is caused by operation check of ABS actuator and electric unit (control unit).
Acceleration may feel insufficient depending on the road conditions.	This is not a malfunction, because it is caused by TCS function that puts the highest priority to obtain the optimum traction (stability).
TCS function may operate momentarily while driving on a road where friction coefficient varies or when downshifting or fully depressing accelerator pedal.	
ABS warning lamp and VDC OFF indicator lamp may turn ON when the vehicle is on a rotating turntable or is given a strong shaking or large vibrations on a ship while the engine is running.	In this case, restart the engine on a normal road. If the normal condition is restored, there is no malfunction. In that case, erase "ABS" self-diagnosis result memory with CONSULT.
VDC warning lamp may turn ON and VDC function, TCS function, brake assist function, and brake force distribution function may not normally operate when driving on a special road the is extremely slanted (bank in a circuit course).	
A malfunction in yaw rate/side/decel G sensor system may be detected when the vehicle sharply turns during a spin turn, acceleration turn or drift driving while VDC function TCS function are OFF (VDC OFF switch is pressed and VDC OFF indicator lamp is in ON status).	
The vehicle speed does not increase, when the accelerator pedal is depressed while the vehicle is on a 2-wheel chassis dynamometer for speedometer check.	This is normal. (When checking the vehicle on a chassis dynamometer, operate VDC OFF switch so that TCS function is OFF.)

WHEEL SENSOR

< REMOVAL AND INSTALLATION >

[WITHOUT ICC]

REMOVAL AND INSTALLATION

WHEEL SENSOR

FRONT WHEEL SENSOR

FRONT WHEEL SENSOR : Exploded View

INFOID:000000012894498

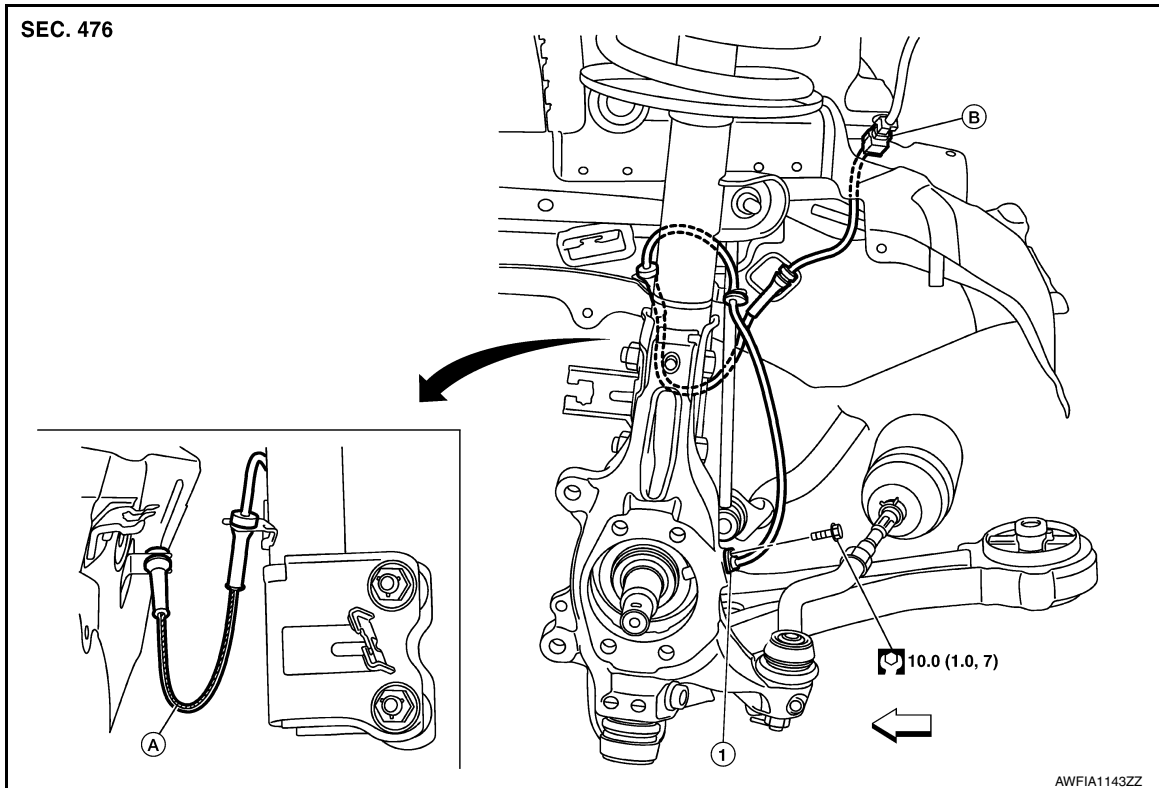

1. Front wheel sensor

A. Color line (slant line)

B. Front wheel sensor harness connector

← Front

FRONT WHEEL SENSOR : Removal and Installation

INFOID:000000012894499

CAUTION:

Do not damage the front wheel sensor or sensor rotor.

REMOVAL

1. Remove front wheel and tire using power tool. Refer to [WT-63, "Balancing Wheels"](#).
2. Remove fender protector retaining pin to gain access to wheel sensor harness connector.
3. Disconnect harness connector from front wheel sensor.
4. Remove front wheel sensor bolt (A) from wheel hub and bearing.

CAUTION:

Pull out the front wheel sensor being careful to turn it as little as possible. Do not pull on the front wheel sensor harness.

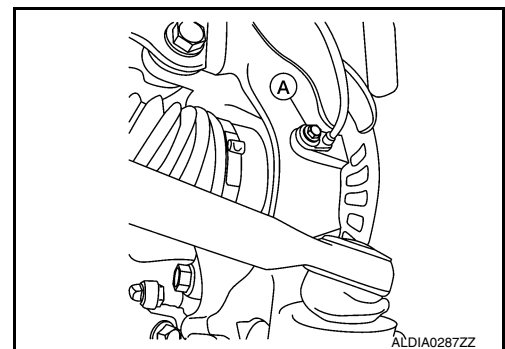

WHEEL SENSOR

< REMOVAL AND INSTALLATION >

[WITHOUT ICC]

5. Remove front wheel sensor from strut bracket.
6. Remove front wheel sensor from steering knuckle.

CAUTION:

Pull out the front wheel sensor being careful to turn it as little as possible. Do not pull on the front wheel sensor harness.

INSTALLATION

Installation is in the reverse order of removal.

CAUTION:

- Before installing, make sure there is no foreign material, such as iron fragments, adhered to the pick-up part of the front wheel sensor.
- When installing, make sure there is no foreign material, such as iron fragments, on and in the hole in the steering knuckle for the front wheel sensor. Make sure no foreign material has been caught in the sensor rotor. Remove any foreign material and clean the mount.
- Do not twist front wheel sensor harness when installing front wheel sensor. Check that grommet (2) is fully inserted to bracket (1). Check that front wheel sensor harness is not twisted after installation.

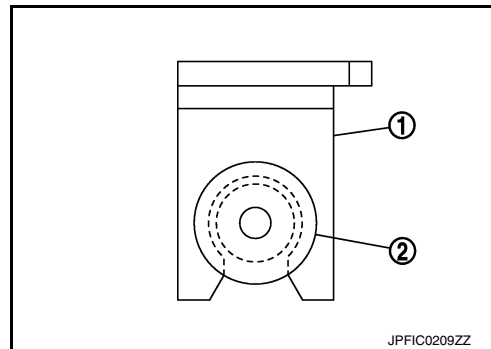

REAR WHEEL SENSOR

REAR WHEEL SENSOR : Exploded View

INFOID:000000012894500

RH Side

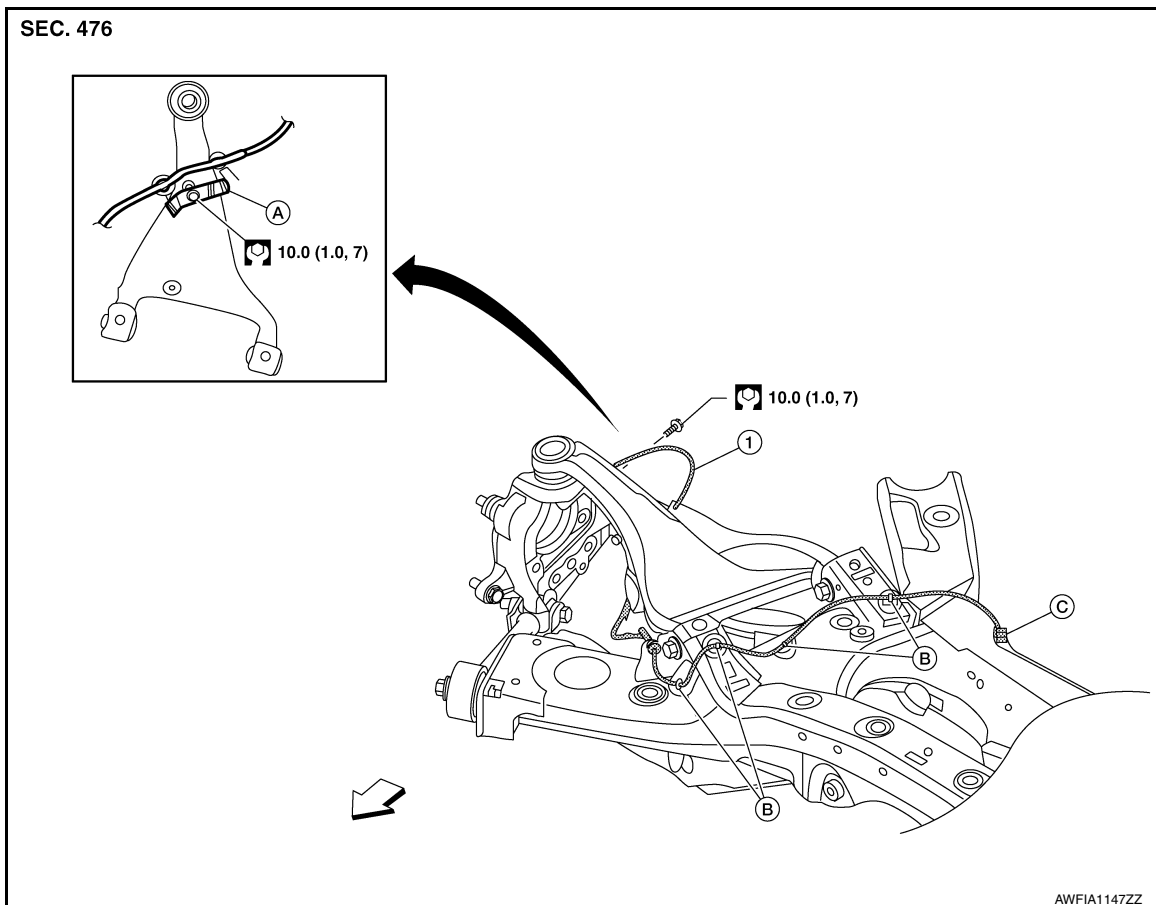

WHEEL SENSOR

< REMOVAL AND INSTALLATION >

[WITHOUT ICC]

- 1. Rear wheel sensor
- A. Rear wheel sensor bracket
- B. Clip
- C. Rear wheel sensor connector
- ⇐ Front

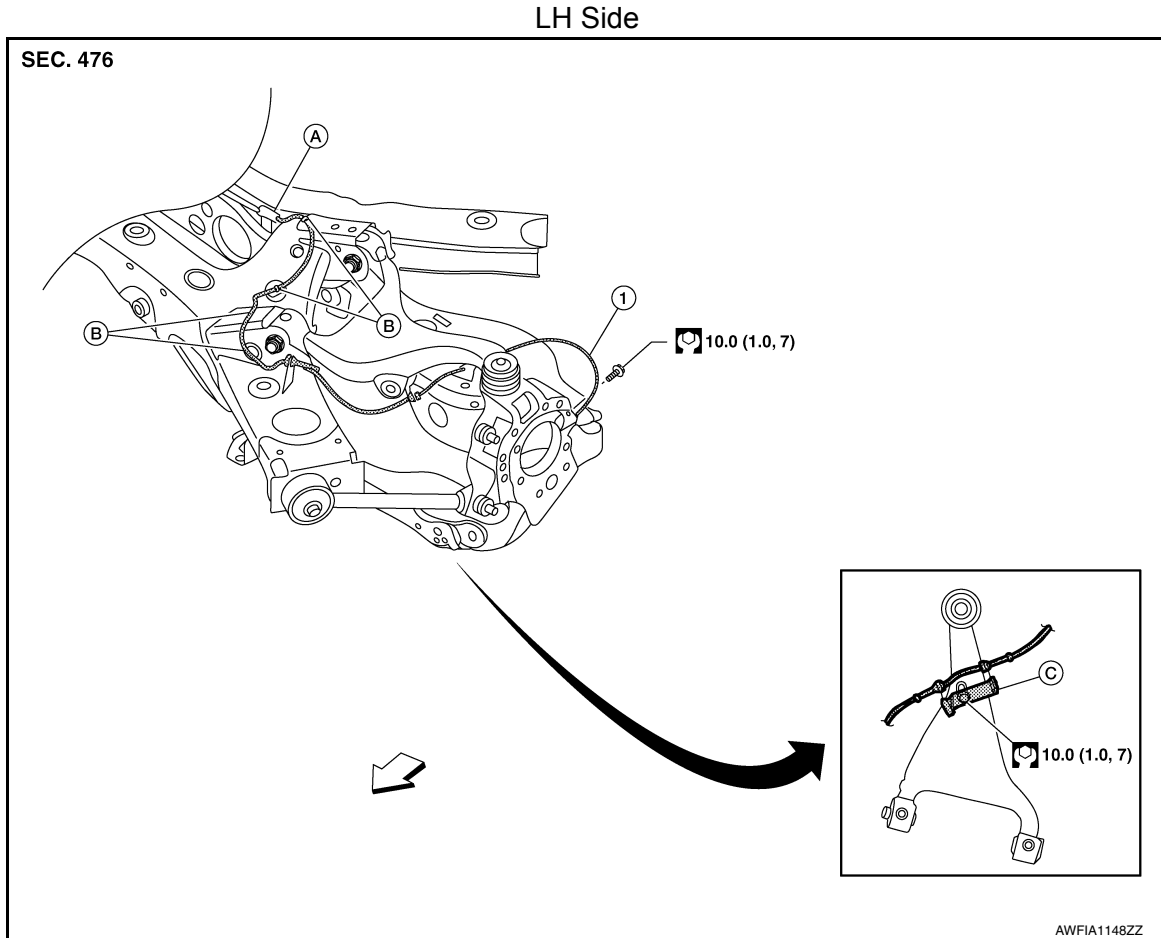

- 1. Rear wheel sensor
- A. Rear wheel sensor connector
- B. Clip
- C. Rear wheel sensor bracket
- ⇐ Front

REAR WHEEL SENSOR : Removal and Installation

INFOID:000000012894501

CAUTION:

Do not damage rear wheel sensor or sensor rotor.

REMOVAL

1. Remove rear under cover. Refer to [EXT-40. "REAR UNDER COVER : Removal and Installation"](#)
2. Remove rear wheel and tire using power tool. Refer to [WT-66. "Removal and Installation"](#).
3. Remove rear wheel sensor bolt (1).

CAUTION:

Pull out the rear wheel sensor being careful to turn it as little as possible. Do not pull on the rear wheel sensor harness.

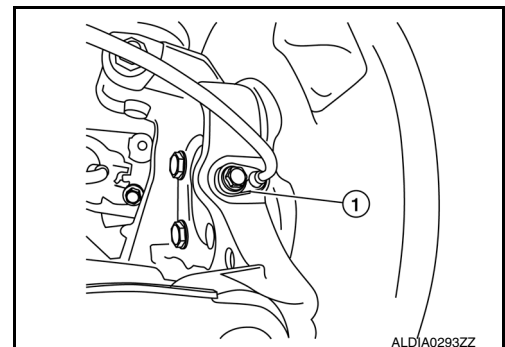

4. Disconnect harness connector from rear wheel sensor.

WHEEL SENSOR

< REMOVAL AND INSTALLATION >

[WITHOUT ICC]

5. Remove rear wheel sensor from sensor brackets.
6. Remove rear wheel sensor from rear knuckle.

CAUTION:

Pull out the rear wheel sensor being careful to turn it as little as possible. Do not pull on the rear wheel sensor harness.

INSTALLATION

Installation is in the reverse order of removal.

CAUTION:

- Before installing, make sure there is no foreign material, such as iron fragments, adhered to the pick-up part of the rear wheel sensor.
- When installing, make sure there is no foreign material, such as iron fragments, on and in the hole in the rear knuckle for the rear wheel sensor. Make sure no foreign material has been caught in the sensor rotor. Remove any foreign material and clean the mount.
- Do not twist rear wheel sensor harness when installing rear wheel sensor. Check that grommet (2) is fully inserted to bracket (1). Check that rear wheel sensor harness is not twisted after installation.

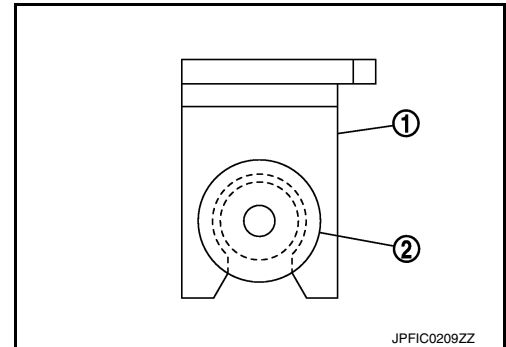

SENSOR ROTOR

< REMOVAL AND INSTALLATION >

[WITHOUT ICC]

SENSOR ROTOR

FRONT SENSOR ROTOR

FRONT SENSOR ROTOR : Removal and Installation - Front Sensor Rotor INFOID:0000000012894502

The front wheel sensor rotor is an integral part of the wheel hub and bearing and cannot be disassembled. Refer to [FAX-8. "Removal and Installation"](#).

REAR SENSOR ROTOR

REAR SENSOR ROTOR : Removal and Installation - Rear Sensor Rotor INFOID:0000000012894503

The rear wheel sensor rotor is an integral part of the wheel hub and bearing and cannot be disassembled. Refer to [RAX-8. "Removal and Installation"](#).

A
B
C
D
E
G
H
I
J
K
L
M
N
O
P

BRC

ABS ACTUATOR AND ELECTRIC UNIT (CONTROL UNIT)

< REMOVAL AND INSTALLATION >

[WITHOUT ICC]

ABS ACTUATOR AND ELECTRIC UNIT (CONTROL UNIT)

Exploded View

INFOID:000000012894504

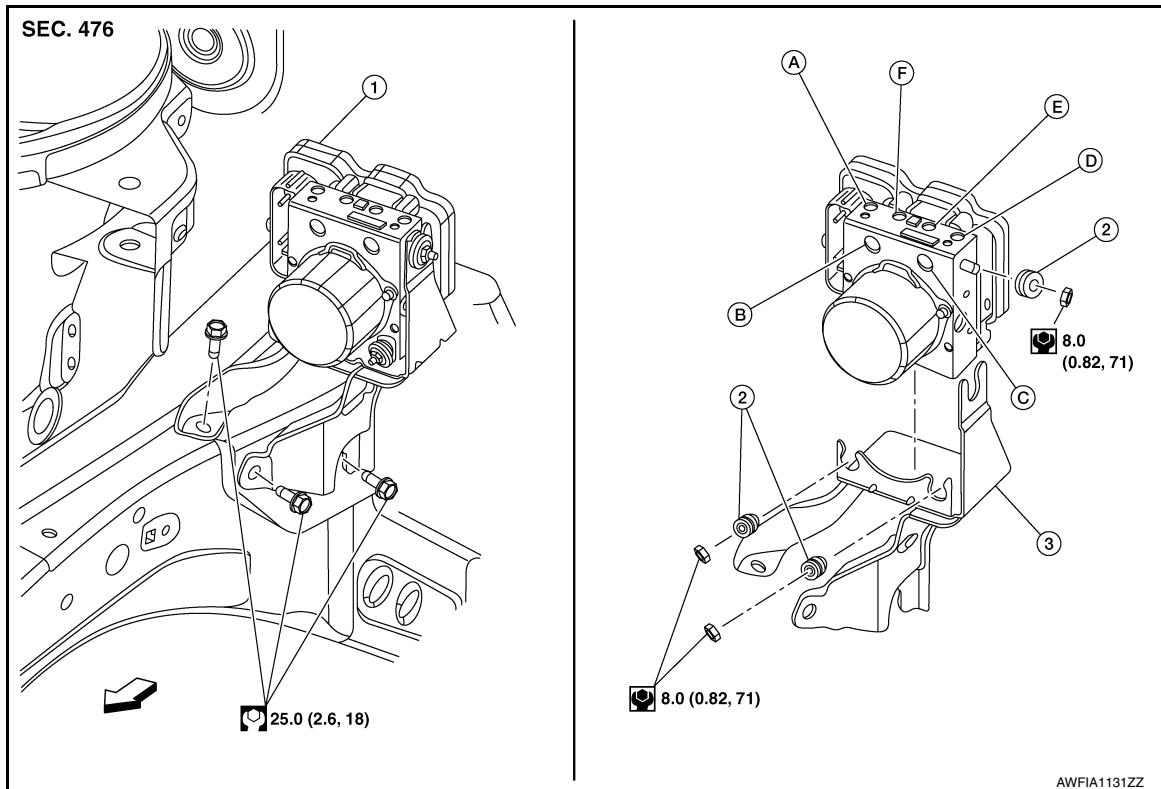

- | | | |
|--|--|--------------------------------------|
| 1. ABS actuator and electric unit (control unit) | 2. Bushings | 3. Bracket |
| A. To rear RH brake caliper | B. From master cylinder secondary side | C. From master cylinder primary side |
| D. To rear LH brake caliper | E. To front RH brake caliper | F. To front LH brake caliper |

↶ Front

Removal and Installation

INFOID:000000012894505

REMOVAL

CAUTION:

- To remove brake tube, use a flare nut wrench to prevent flare nuts and brake tube from being damaged.
- Do not remove actuator by holding harness.

NOTE:

- Before replacing ABS actuator and electric unit (control unit), use the CONSULT to check the ABS actuator and electric unit (control unit) type ID. Refer to [BRC-66. "Work Procedure"](#).
 - When removing components such as hoses, tubes/lines, etc., cap or plug openings to prevent fluid from spilling.
1. Disconnect negative battery terminal. Refer to [PG-112. "Exploded View"](#).
 2. Remove cowl top cover. Refer to [EXT-34. "Removal and Installation - Cowl Top Cover"](#).
 3. Remove cowl top extension. Refer to [EXT-35. "Removal and Installation - Cowl Top Extension"](#).
 4. Separate brake tubes from ABS actuator and electric unit (control unit). Refer to [BR-22. "FRONT : Exploded View"](#).
 5. Disconnect harness connector from ABS actuator and electric unit (control unit).
 6. Remove ABS actuator and electric unit (control unit) bracket nuts, bolts and bushings.
 7. Remove ABS actuator and electric unit (control unit) from vehicle.

INSTALLATION

ABS ACTUATOR AND ELECTRIC UNIT (CONTROL UNIT)

< REMOVAL AND INSTALLATION >

[WITHOUT ICC]

CAUTION:

Be sure to perform "Manual Configuration" when replacing ABS actuator and electric unit (control unit). Refer to [BRC-66, "Work Procedure"](#).

Installation is in the reverse order of removal.

- After work is completed, bleed air from brake tube. Refer to [BR-14, "Bleeding Brake System"](#).
- Adjust the neutral position of steering angle sensor. Refer to [BRC-62, "Work Procedure"](#).
- Perform calibration of the decel G sensor. Refer to [BRC-64, "Work Procedure"](#).

CAUTION:

- To install, use flare nut crowfoot and torque wrench.
- Replace the ABS actuator if it has been dropped or sustained an impact.
- Do not install actuator by holding harness.
- After installing harness connector in the ABS actuator and electric unit (control unit), make sure connector is securely locked.

A
B
C
D
E
G
H
I
J
K
L
M
N
O
P

BRC

VDC OFF SWITCH

< REMOVAL AND INSTALLATION >

[WITHOUT ICC]

VDC OFF SWITCH

Exploded View

INFOID:000000012894506

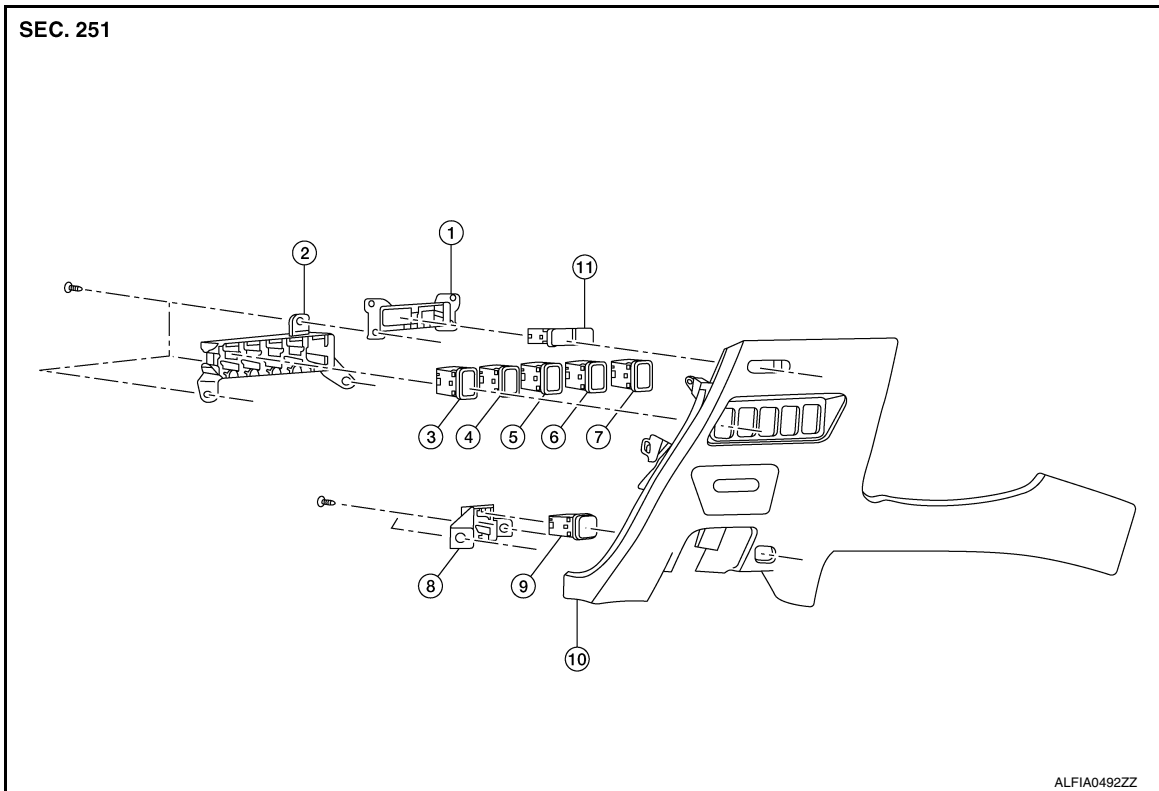

- | | | |
|-------------------------------|---------------------------------|---------------------------------|
| 1. Upper switch carrier | 2. Middle switch carrier | 3. VDC OFF switch |
| 4. Mask | 5. Automatic back door switch | 6. Heated steering wheel switch |
| 7. Mask | 8. Lower switch carrier | 9. Front power return switch |
| 10. Instrument lower panel LH | 11. Illumination control switch | |

Removal and Installation

INFOID:000000012894507

REMOVAL

1. Remove instrument lower panel LH. Refer to [IP-24. "Removal and Installation"](#).
2. Remove screws and middle switch carrier from instrument lower panel LH.
3. Release pawls using suitable tool and remove VDC OFF switch from middle switch carrier.

○: Pawl

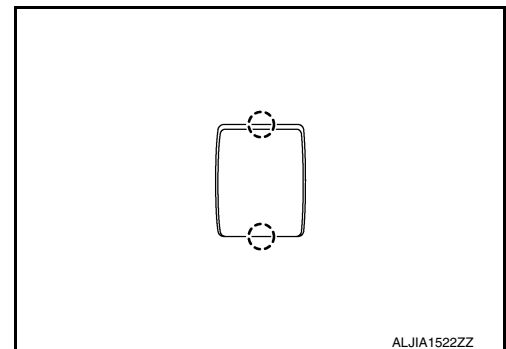

INSTALLATION

Installation is in the reverse order of removal.

STEERING ANGLE SENSOR

< REMOVAL AND INSTALLATION >

[WITHOUT ICC]

STEERING ANGLE SENSOR

Exploded View

INFOID:000000012894508

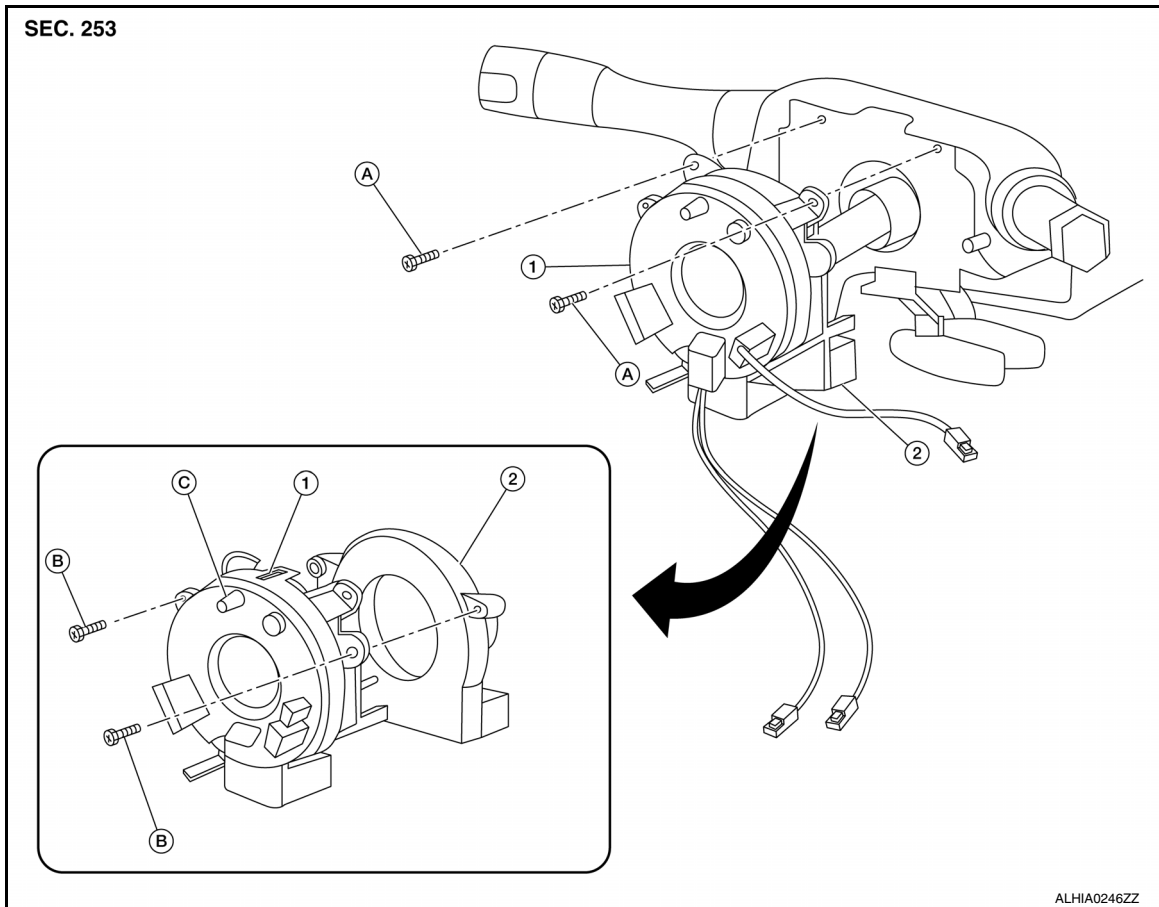

- | | | |
|---------------------------------|--------------------------|------------------------|
| 1. Spiral cable | 2. Steering angle sensor | A. Spiral cable screws |
| B. Steering angle sensor screws | C. Locating pin | |

Removal and Installation

INFOID:000000012894509

To remove and install the steering angle sensor, remove and install the spiral cable. Refer to [SR-15, "Removal and Installation"](#).

PRECAUTION

PRECAUTIONS

Precaution for Supplemental Restraint System (SRS) "AIR BAG" and "SEAT BELT PRE-TENSIONER"

INFOID:000000012894510

The Supplemental Restraint System such as "AIR BAG" and "SEAT BELT PRE-TENSIONER", used along with a front seat belt, helps to reduce the risk or severity of injury to the driver and front passenger for certain types of collision. Information necessary to service the system safely is included in the SR and SB section of this Service Manual.

WARNING:

- To avoid rendering the SRS inoperative, which could increase the risk of personal injury or death in the event of a collision which would result in air bag inflation, it is recommended that all maintenance and repair be performed by an authorized NISSAN/INFINITI dealer.
- Improper repair, including incorrect removal and installation of the SRS, can lead to personal injury caused by unintentional activation of the system. For removal of Spiral Cable and Air Bag Module, see the SR section.
- Do not use electrical test equipment on any circuit related to the SRS unless instructed to in this Service Manual. SRS wiring harnesses can be identified by yellow and/or orange harnesses or harness connectors.

PRECAUTIONS WHEN USING POWER TOOLS (AIR OR ELECTRIC) AND HAMMERS

WARNING:

- When working near the Air Bag Diagnosis Sensor Unit or other Air Bag System sensors with the Ignition ON or engine running, DO NOT use air or electric power tools or strike near the sensor(s) with a hammer. Heavy vibration could activate the sensor(s) and deploy the air bag(s), possibly causing serious injury.
- When using air or electric power tools or hammers, always switch the Ignition OFF, disconnect the battery or batteries, and wait at least three minutes before performing any service.

Precaution for Procedure without Cowl Top Cover

INFOID:000000012894511

When performing the procedure after removing cowl top cover, cover the lower end of windshield with urethane, etc. to prevent damage to windshield.

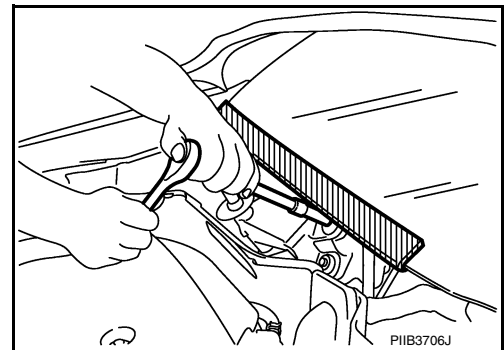

Precaution for Brake System

INFOID:000000012894512

WARNING:

Clean any dust from the front brake and rear brake using a vacuum dust collector. Do not blow by compressed air.

- Brake fluid use refer to [BR-8. "Inspection"](#).
- Do not reuse drained brake fluid.
- Do not spill or splash brake fluid on painted surfaces. Brake fluid may seriously damage paint. Wipe it off immediately and wash with water if it gets on a painted surface.
- Always confirm the specified tightening torque when installing the brake pipes.
- After pressing the brake pedal more deeply or harder than normal driving, such as air bleeding, check each item of brake pedal. Adjust brake pedal if it is outside the standard value.
- Do not use mineral oils such as gasoline or light oil to clean. They may damage rubber parts and cause improper operation.
- Always loosen the brake tube flare nut with a flare nut wrench.

PRECAUTIONS

[WITH ICC]

< PRECAUTION >

- Tighten the brake tube flare nut to the specified torque with a flare nut crowfoot (A) and torque wrench (B).
- Always connect the battery terminal when moving the vehicle.
- Turn the ignition switch OFF and disconnect the ABS actuator and electric unit (control unit) harness connector or the battery negative terminal before performing the work.
- Check that no brake fluid leakage is present after replacing the parts.

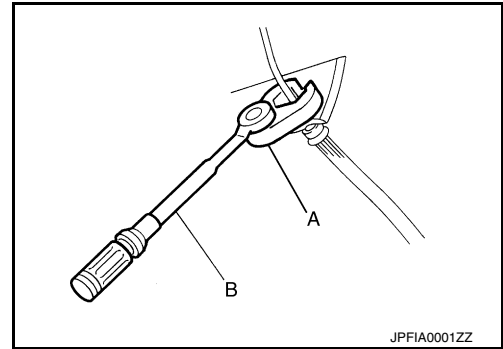

Precaution for Brake Control System

INFOID:0000000012894513

- Just after starting vehicle after ignition switch is ON, brake pedal may vibrate or motor operating noise may be heard from engine compartment. This is a normal condition.
- When an error is indicated by ABS or another warning lamp, collect all necessary information from customer (what symptoms are present under what conditions) and check for simple causes before starting diagnostic servicing. Besides electrical system inspection, check brake booster operation, brake fluid level and oil leaks.
- If tire size and type are used in an improper combination or brake pads are not Genuine NISSAN parts, stopping distance or steering stability may deteriorate.
- ABS might be out of order or malfunctions by putting a radio (wiring inclusive), an antenna and a lead-in wire near the control unit.
- If aftermarket parts (car stereo, CD player, etc.) have been installed, check for incidents such as harness pinches, open circuits, and improper wiring.
- VDC system may not operate normally or a VDC OFF indicator lamp or SLIP indicator lamp may light.
- When replacing the following parts with parts other than genuine parts or making modifications: Suspension-related parts (shock absorber, spring, bushing, etc.), tires, wheels (other than specified sizes), brake-related parts (pad, rotor, caliper, etc.), engine-related parts (muffler, ECM, etc.) and body reinforcement-related parts (roll bar, tower bar, etc.).
- When driving with worn or deteriorated suspension, tires and brake-related parts.

Precaution for Harness Repair

INFOID:0000000012894514

- Solder the repair part, and wrap it with tape. [Twisted wire fray must be 110 mm (4.33 in) or less.]

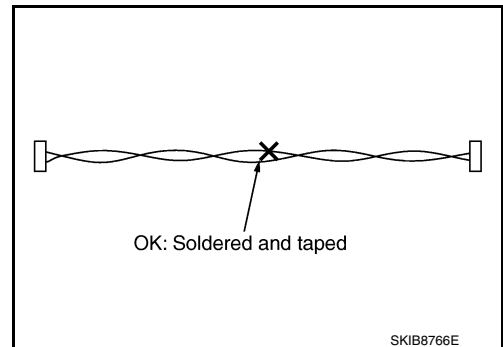

- Do not bypass the repair point with wire. (If it is bypassed, the turn-out point cannot be separated and the twisted wire characteristics are lost.)

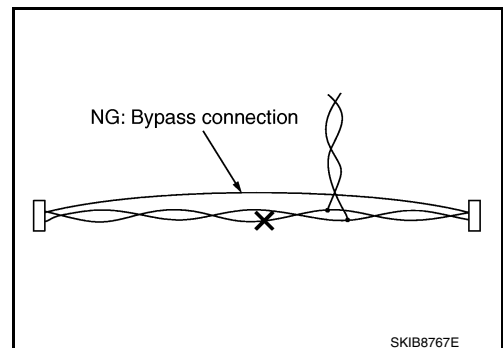

PRECAUTIONS

< PRECAUTION >

[WITH ICC]

Precautions for FEB System Service

INFOID:000000012894515

CAUTION:

- Never use the ICC sensor removed from vehicle. Never disassemble or remodel.
- Erase DTC when replacing parts of ICC system. Then check the operation of ICC system after radar alignment if necessary.
- Never change FEB system state ON/OFF without the consent of the customer.
- Turn the FEB system OFF in conditions similar to driving, such as free rollers or a chassis dynamometer.

PREPARATION

< PREPARATION >

[WITH ICC]

PREPARATION

PREPARATION

Special Service Tool

INFOID:0000000012894516

The actual shape of the tools may differ from those illustrated here.

Tool number (TechMate No.) Tool name	Description
KV991J0080 (J-45741) ABS active wheel sensor tester	Checking operation of ABS active wheel sensors
— (1-20-2851-1) ICC Alignment Kit	Adjusting ICC sensor
— (1-20-2722-1-IF) Wheel Adaptor	Adjusting ICC sensor

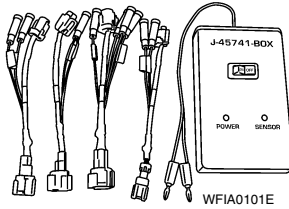

WFIA0101E

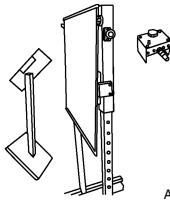

AWOIA0016ZZ

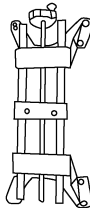

AWOIA0017ZZ

Commercial Service Tools

INFOID:0000000012894517

Tool name	Description
1. Flare nut crowfoot 2. Torque wrench	Tightening brake tube flare nuts a: 10 mm (0.39 in)/12 mm (0.47 in)
Power tool	Loosening nuts, screws and bolts

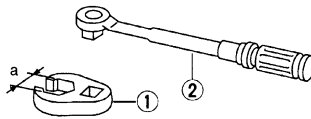

S-NT360



PIIB1407E

COMPONENT PARTS

< SYSTEM DESCRIPTION >

[WITH ICC]

SYSTEM DESCRIPTION

COMPONENT PARTS

Component Parts Location

INFOID:000000012894518

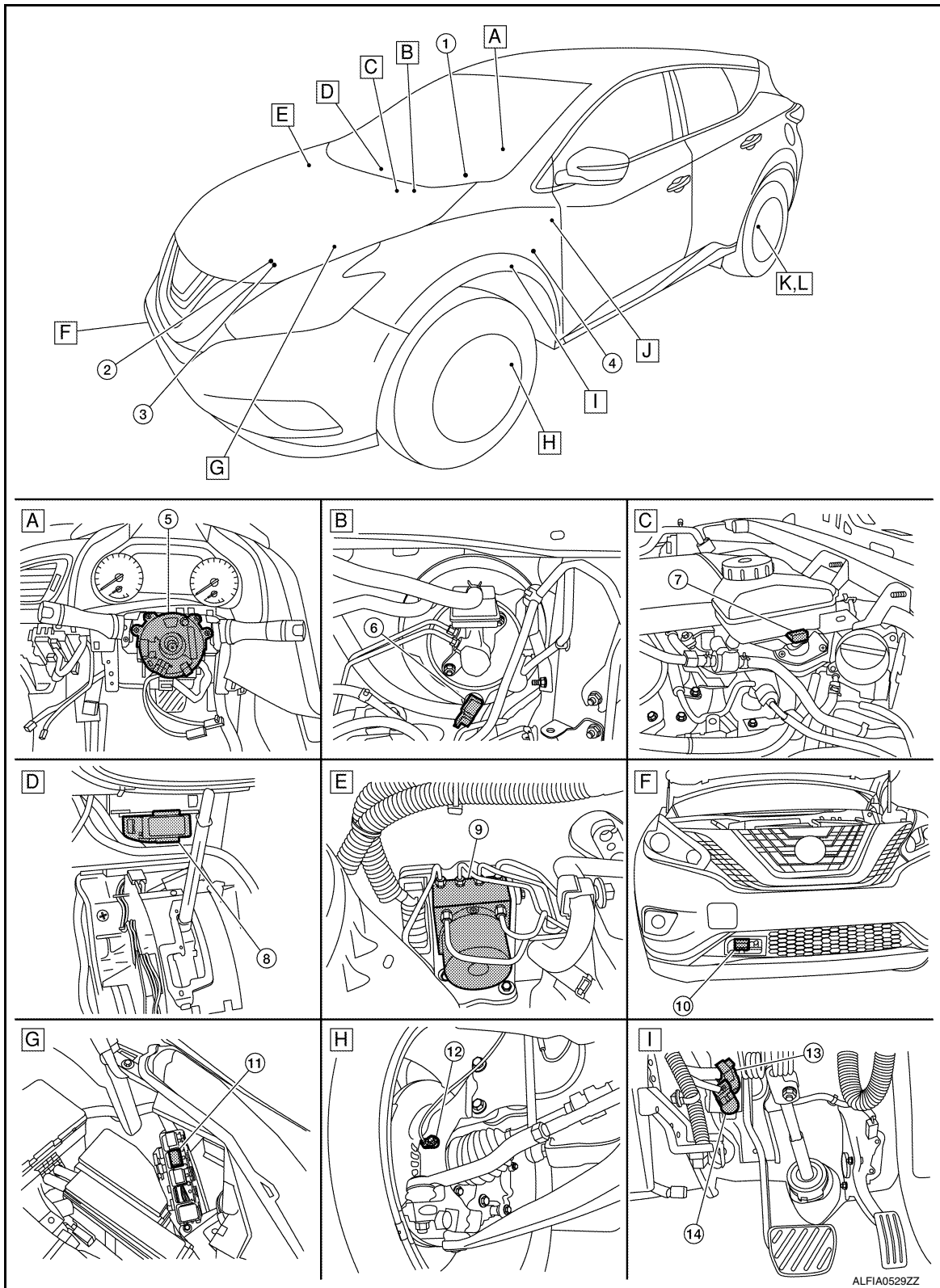

COMPONENT PARTS

< SYSTEM DESCRIPTION >

[WITH ICC]

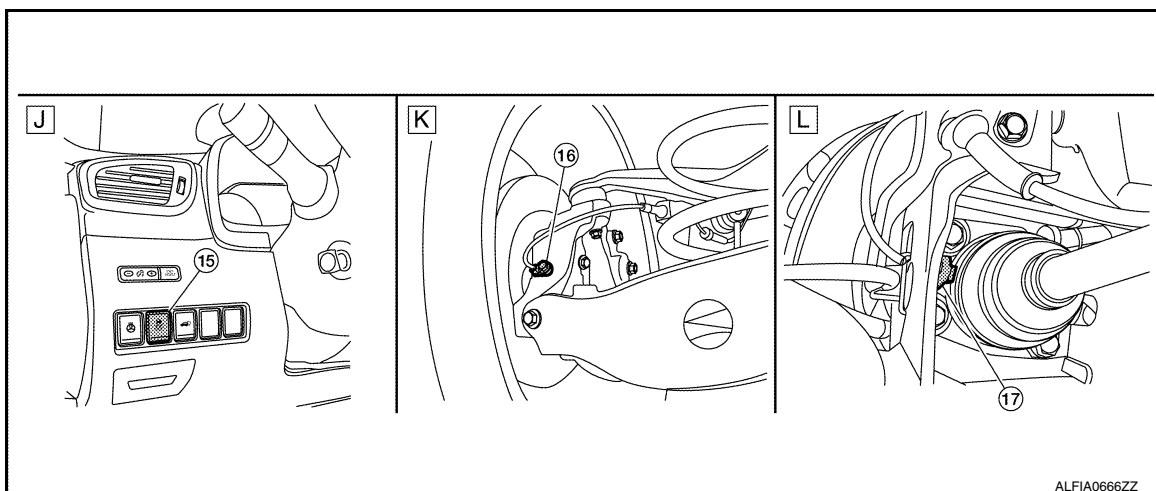

- | | | |
|---|--------------------------------------|--------------------------------------|
| A. Steering column (view with steering wheel removed) | B. Engine room (LH) | C. Engine room (LH) |
| D. Instrument panel (Center) | E. Engine room (RH) | F. Front bumper (RH) |
| G. Engine room (LH) | H. Left front wheel area | I. Brake pedal area |
| J. Left side of instrument panel | K. Left rear wheel area (FWD models) | L. Left rear wheel area (AWD models) |

BRC

No.	Component	Description
1.	Combination meter	<ul style="list-style-type: none"> Performs the following operations using the signals received from the ADAS control unit via the CAN communication - Displays the FEB system operation status using the meter display signal - Illuminates the FEB warning lamp using the FEB warning lamp signal Refer to MWI-5, "METER SYSTEM : Component Parts Location" for detailed installation location.
2.	TCM	<ul style="list-style-type: none"> TCM transmits the signal related to CVT control to ADAS control unit via CAN communication Refer to TM-13, "CVT CONTROL SYSTEM : TCM" for detailed installation location.
3.	ECM	<ul style="list-style-type: none"> ECM transmits the accelerator pedal position signal via CAN communication Refer to EC-15, "ENGINE CONTROL SYSTEM : Component Parts Location" for detailed installation location.
4.	Driver assistance buzzer	Refer to BRC-186, "Warning Buzzer" .
5.	Steering angle sensor	Refer to BRC-183, "Steering Angle Sensor"
6.	Vacuum sensor	Refer to BRC-184, "Vacuum Sensor"
7.	Brake fluid level switch	Refer to BRC-184, "Brake Fluid Level Switch"
8.	ADAS control unit (view with center console removed)	<ul style="list-style-type: none"> Refer to BRC-185, "ADAS Control Unit". Refer to DAS-6, "Component Parts Location" for detailed installation location.
9.	ABS actuator and electric unit (control unit)	<ul style="list-style-type: none"> ABS actuator and electric unit (control unit) transmits the vehicle speed signal (wheel speed), stop lamp signal and VDC/TCS/ABS system operation condition to ADAS control unit via CAN communication ABS actuator and electric unit (control unit) controls the brake, based on a brake fluid pressure control signal received from ADAS control unit via CAN communication Refer to BRC-172, "Removal and Installation" for detailed installation location.
10.	ICC sensor	Refer to BRC-185, "ICC Sensor" .
11.	ICC brake hold relay	Refer to BRC-186, "ICC Brake Hold Relay" .
12.	Front LH wheel sensor	Refer to BRC-182, "Wheel Sensor and Sensor Rotor"
13.	Brake pedal position switch	Refer to BRC-185, "Brake Pedal Position Switch / Stop Lamp Switch" .
14.	Stop lamp switch	
15.	VDC off switch	Refer to BRC-184, "VDC OFF Switch"

COMPONENT PARTS

[WITH ICC]

< SYSTEM DESCRIPTION >

No.	Component	Description
16.	Rear LH wheel sensor (FWD models)	Refer to BRC-182, "Wheel Sensor and Sensor Rotor"
17.	Rear LH wheel sensor (AWD models)	Refer to BRC-182, "Wheel Sensor and Sensor Rotor"

Wheel Sensor and Sensor Rotor

INFOID:000000012894519

NOTE:

- Wheel sensor of front wheel is installed on steering knuckle.
- Sensor rotor of front wheel is integrated into the wheel hub assembly.
- Wheel sensor of rear wheel is installed on rear final drive.
- Sensor rotor of rear wheel is installed on drive shaft (rear final drive side).
- Never measure resistance and voltage value using a tester because sensor is an active sensor.

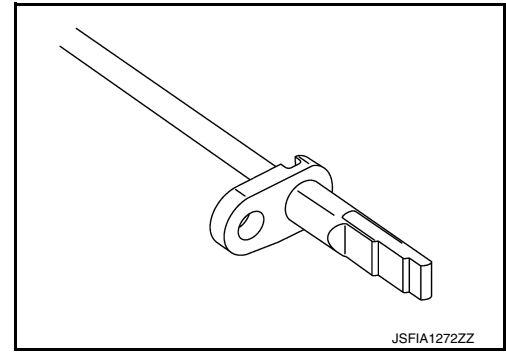

- Power supply is supplied to detection portion so that magnetic field line is read. Magnetic field that is detected is converted to current signal.
- When sensor rotor rotates, magnetic field changes. Magnetic field change is converted to current signals (rectangular wave) and is transmitted to ABS actuator and electric unit (control unit). Change of magnetic field is proportional to wheel speed.

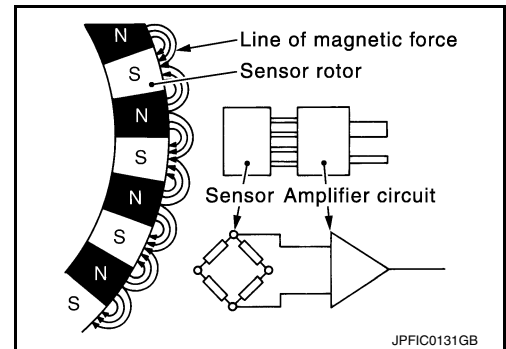

ABS Actuator and Electric Unit (Control Unit)

INFOID:000000012894520

Electric unit (control unit) is integrated with actuator and comprehensively controls VDC function, TCS function, ABS function, EBD function, brake assist function and hill start assist function.

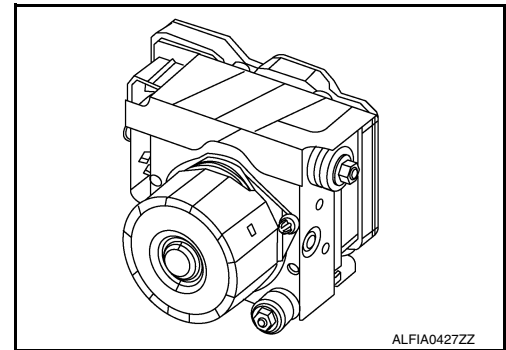

ELECTRIC UNIT (CONTROL UNIT)

- Brake fluid pressure, engine and transmission are controlled according to signals from each sensor.
- If malfunction is detected, the system enters fail-safe mode.

ACTUATOR

The following components are integrated with ABS actuator:

Pump

Returns the brake fluid reserved in reservoir to master cylinder by reducing pressure.

Motor

Activates the pump according to signals from ABS actuator and electric unit (control unit).

Motor Relay

COMPONENT PARTS

[WITH ICC]

< SYSTEM DESCRIPTION >

Operates the motor ON/OFF according to signals from ABS actuator and electric unit (control unit).

Actuator Relay

Operates each valve ON/OFF according to signals from ABS actuator and electric unit (control unit).

ABS IN Valve and ABS OUT Valve

Increases, holds or decreases the fluid pressure of each caliper according to signals from ABS actuator and electric unit (control unit).

Pressure Sensor

Detects the brake fluid pressure and transmits signal to ABS actuator and electric unit (control unit).

Cut Valve 1 (Primary Line), Cut Valve 2 (Secondary Line)

Shuts off the ordinary brake line from master cylinder when VDC function, TCS function, brake assist function, hill start assist function are activated.

Yaw Rate/Side/Decel G Sensor

Calculates the following information that affects the vehicle and transmits a signal to ABS actuator and electric unit (control unit). [Yaw rate/side/decel G sensor is integrated into the ABS actuator and electric unit (control unit).]

- Vehicle rotation angular velocity (yaw rate signal)
- Vehicle lateral acceleration (side G signal)
- Vehicle longitudinal acceleration (decel G signal)

Stop Lamp Switch

INFOID:0000000012894521

Detects the operation status of brake pedal and transmits converted electric signal to ABS actuator and electric unit (control unit).

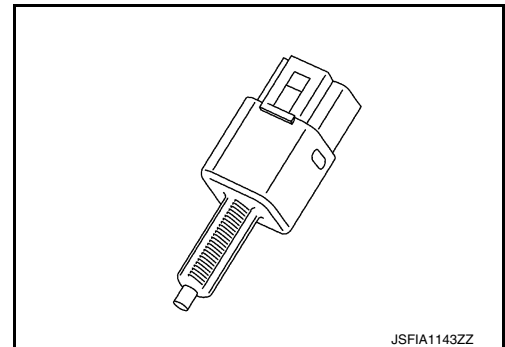

Steering Angle Sensor

INFOID:0000000012894522

Detects the following information and transmits steering angle signal to ABS actuator and electric unit (control unit) via CAN communication:

- Steering angle sensor malfunction signal
- Steering wheel rotation amount
- Steering wheel rotation angular velocity
- Steering wheel rotation direction

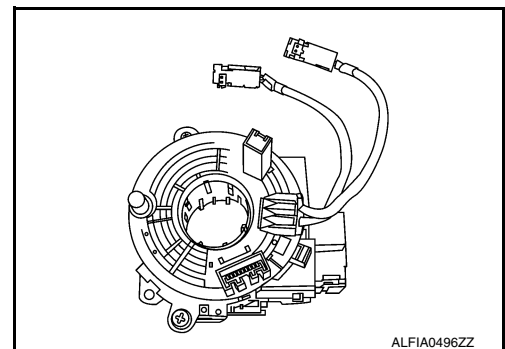

A
B
C
D
E
G
H
I
J
K
L
M
N
O
P

BRC

COMPONENT PARTS

< SYSTEM DESCRIPTION >

[WITH ICC]

Brake Fluid Level Switch

INFOID:000000012894523

Detects the brake fluid level in reservoir tank and transmits converted electric signal from combination meter to ABS actuator and electric unit (control unit) via CAN communication when brake fluid level is the specified level or less.

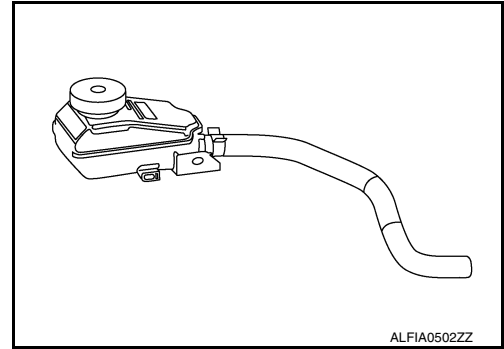

Vacuum Sensor

INFOID:000000012894524

Detects the vacuum in brake booster and transmits converted electric signal to ABS actuator and electric unit (control unit).

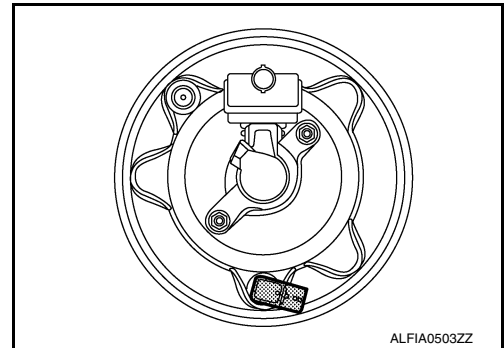

Parking Brake Switch

INFOID:000000012894525

Detects the operation status of parking brake switch and transmits converted electric signal from combination meter to ABS actuator and electric unit (control unit).

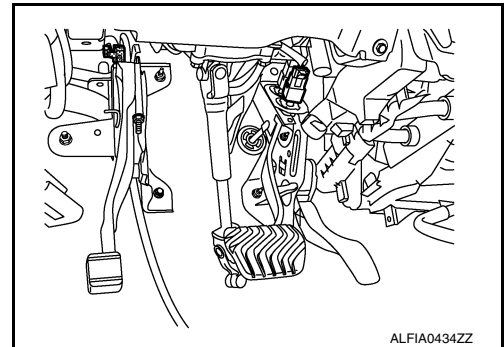

VDC OFF Switch

INFOID:000000012894526

- This is an integrated switch with switches for other functions.
- Non-operational status or standby status of the following functions can be selected using VDC OFF switch. VDC OFF indicator lamp indicates the operation status of function (ON: Non-operational status, OFF: Standby status).
 - Vehicle Dynamic Control function
 - Traction Control System function
 - Forward Emergency Braking function

NOTE:

ABS function, EBD function operate.

- VDC OFF indicator lamp turns OFF (standby status) when the engine is started again after it is stopped once while VDC OFF indicator lamp is ON (non-operational status).

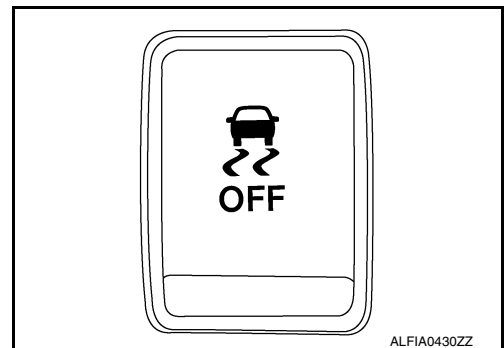

COMPONENT PARTS

< SYSTEM DESCRIPTION >

[WITH ICC]

ADAS Control Unit

INFOID:000000012894527

- ADAS control unit is at the front of center console.
- Communicates with each control unit via CAN communication/ITS communication/Chassis communication.
- ADAS control unit included gateway function, and necessary for system control signals are transmitted to each control unit between CAN communication and ITS communication by the ADAS control unit.
- ADAS control unit controls the each system, based on ITS communication signal, CAN communication signal, and chassis communication signal from each control unit.

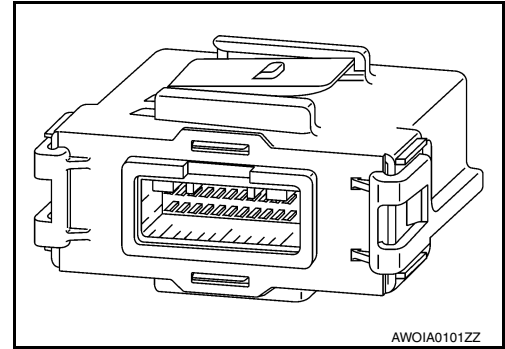

ICC Sensor

INFOID:000000012894528

- ICC sensor is installed on the front of the vehicle and detects a vehicle ahead by using millimeter waves.
- ICC sensor detects radar reflected from a vehicle ahead by irradiating radar forward and calculates a distance from the vehicle ahead and relative speed, based on the detected signal.
- ICC sensor transmits information for ICC from the vehicle to ADAS control unit via ITS communication.

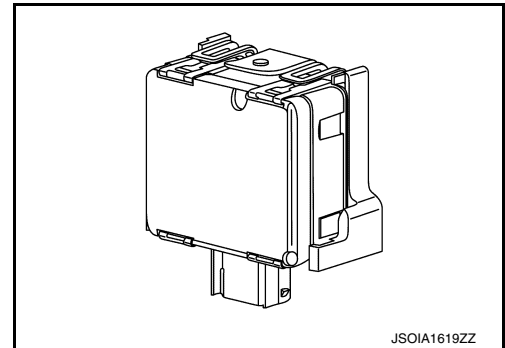

Brake Pedal Position Switch / Stop Lamp Switch

INFOID:000000012894529

- Brake pedal position switch is installed at the upper part of the brake pedal and detects a brake operation performed by the driver.

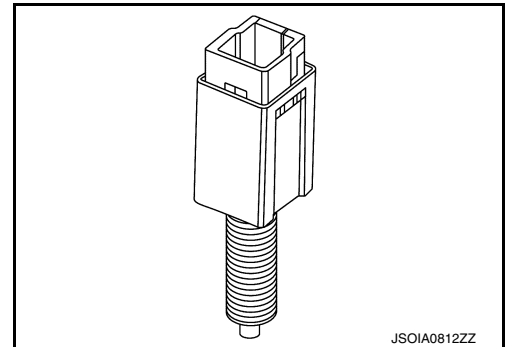

- Brake pedal position switch is turned OFF when depressing the brake pedal.
- Brake pedal position switch signal is input to ECM. Brake pedal position switch signal is transmitted from ECM to ADAS control unit via CAN communication.
- Stop lamp switch is installed at the upper part of the brake pedal and detects a brake operation performed by the driver.
- Stop lamp switch is turned ON, when depressing the brake pedal.
- Stop lamp switch signal is input to ECM and ABS actuator and electric unit (control unit). Stop lamp switch signals are transmitted from ECM and ABS actuator and electric unit (control unit) to ADAS control unit via CAN communication.

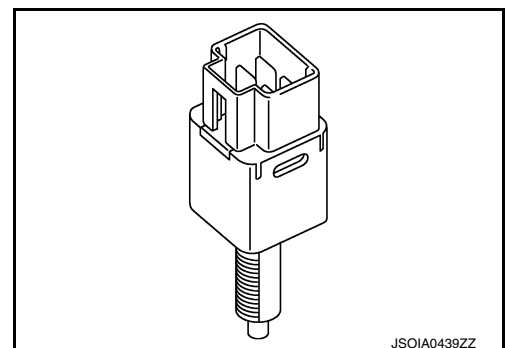

A
B
C
D
E
BRC
G
H
I
J
K
L
M
N
O
P

COMPONENT PARTS

< SYSTEM DESCRIPTION >

[WITH ICC]

ICC Brake Hold Relay

INFOID:000000012894530

- ICC brake hold relay is installed in the engine room (right side).
- When the brake is activated by the system, the ICC brake hold relay turns ON the stop lamp by bypassing the circuit of the stop lamp, according to a signal transmitted from the ADAS control unit.

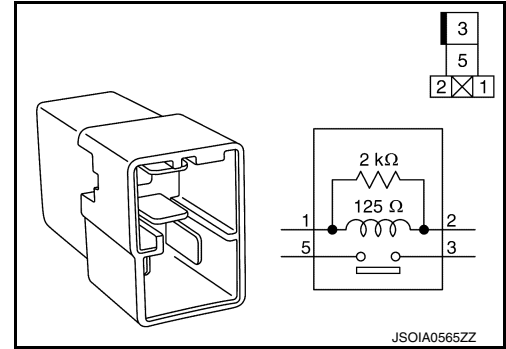

Warning Buzzer

INFOID:000000012894531

- Warning buzzer is installed behind the finisher to the left of the left knee airbag module.
- When a warning buzzer signal is received from the ADAS control module, the warning buzzer sounds a buzzer.

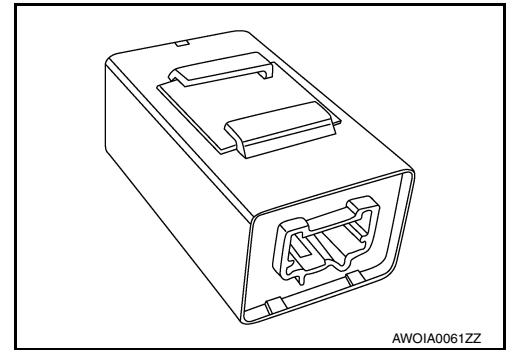

SYSTEM

< SYSTEM DESCRIPTION >

[WITH ICC]

SYSTEM

System Description

INFOID:000000012894532

- The system switches fluid pressure of each brake caliper to increase, hold or decrease according to signals from control unit in ABS actuator and electric unit (control unit). This control system is applied to VDC function, TCS function, ABS function, EBD function, brake assist function, hill start assist function and forward emergency braking function.
- Fail-safe function is available for each function and is activated by each function when system malfunction occurs.

SYSTEM DIAGRAM

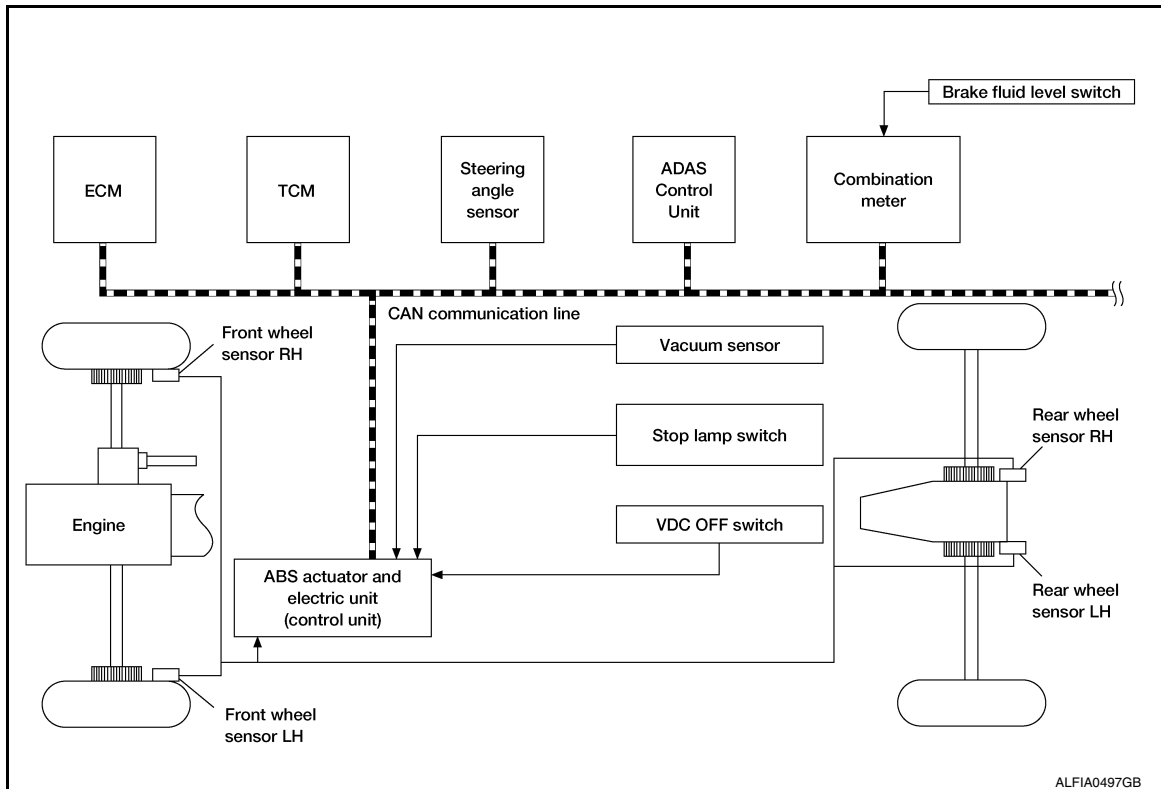

INPUT SIGNAL AND OUTPUT SIGNAL

Major signal transmission between each unit via communication lines is shown in the following table:

Component	Signal description
ECM	<p>Mainly transmits the following signals to ABS actuator and electric unit (control unit) via CAN communication:</p> <ul style="list-style-type: none"> • Accelerator pedal position signal • Engine speed signal • Engine torque signal <p>Mainly receives the following signal from ABS actuator and electric unit (control unit) via CAN communication:</p> <ul style="list-style-type: none"> • Engine torque request signal
TCM	<p>Mainly transmits the following signal to ABS actuator and electric unit (control unit) via CAN communication:</p> <ul style="list-style-type: none"> • Current gear position signal

SYSTEM

< SYSTEM DESCRIPTION >

[WITH ICC]

Component	Signal description
Combination meter	Mainly receives the following signals from ABS actuator and electric unit (control unit) via CAN communication: <ul style="list-style-type: none"> • Brake fluid level switch signal • Parking brake switch signal
	Mainly receives the following signals from ABS actuator and electric unit (control unit) via CAN communication: <ul style="list-style-type: none"> • Brake warning lamp signal • ABS warning lamp signal • VDC warning lamp signal • VDC OFF indicator lamp signal
Steering angle sensor	Mainly transmits the following signals to ABS actuator and electric unit (control unit) via CAN communication: <ul style="list-style-type: none"> • Steering angle sensor signal • Steering angle sensor malfunction signal

VALVE OPERATION (ABS AND EBD)

Each valve is operated and fluid pressure of brake caliper is controlled.

When ordinary brake is applied and ABS is in operation (when pressure increases).

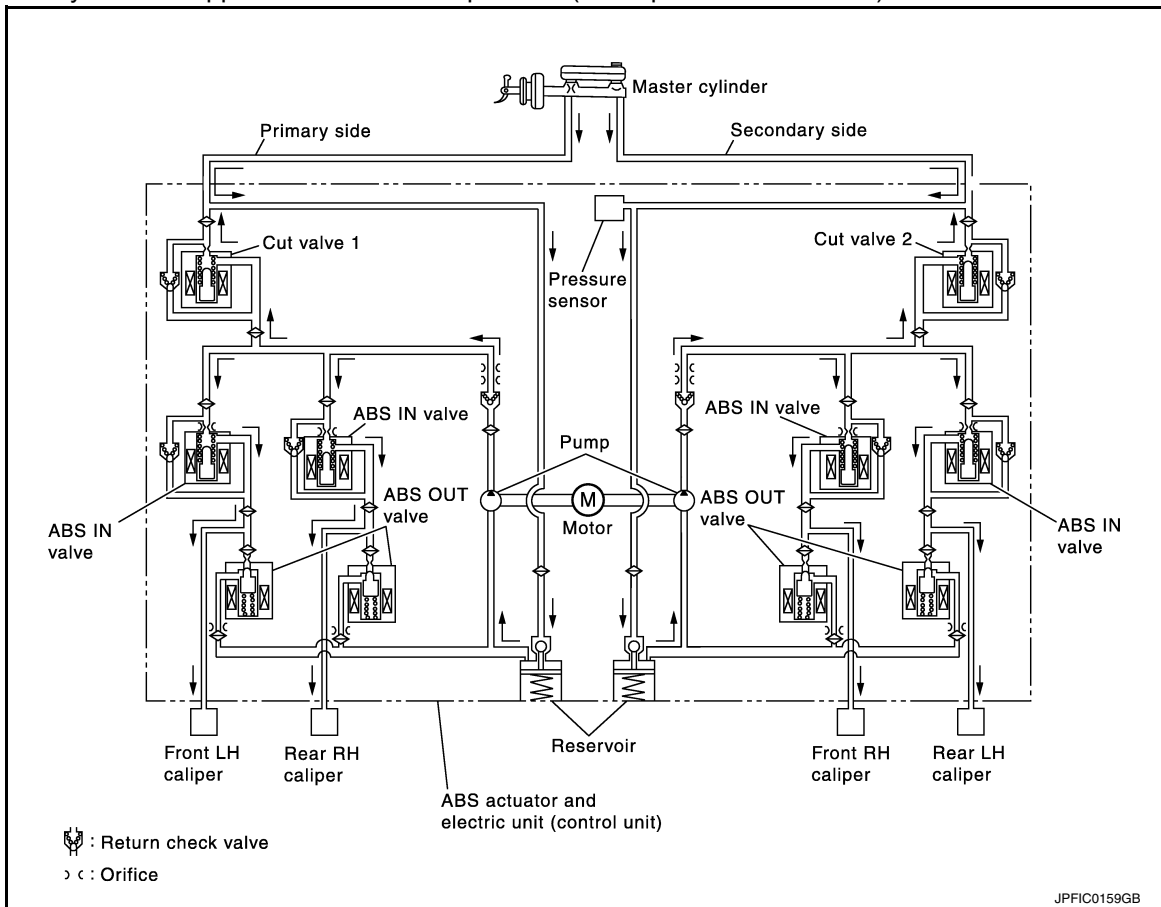

Name	Not activated	When pressure increases
Cut valve 1	Power supply is not supplied (open)	Power supply is not supplied (open)
Cut valve 2	Power supply is not supplied (open)	Power supply is not supplied (open)
ABS IN valve	Power supply is not supplied (open)	Power supply is not supplied (open)
ABS OUT valve	Power supply is not supplied (close)	Power supply is not supplied (close)
Each caliper (fluid pressure)	—	Pressure increases

When front RH wheel caliper pressure increases

SYSTEM

[WITH ICC]

< SYSTEM DESCRIPTION >

- Motor is activated. Brake fluid is pressurized by pump and is sent to secondary line through cut valve 2. At the same time, pressurized brake fluid is supplied to front RH caliper through ABS IN valve.

When front LH wheel caliper pressure increases

- Motor is activated. Brake fluid is pressurized by pump and is sent to primary line through cut valve 1. At the same time, pressurized brake fluid is supplied to front LH wheel caliper through ABS IN valve.

When rear RH wheel caliper pressure increases

- Motor is activated. Brake fluid is pressurized by pump and is sent to primary line through cut valve 1. At the same time, pressurized brake fluid is supplied to rear RH wheel caliper through ABS IN valve.

When rear LH wheel caliper pressure increases

- Motor is activated. Brake fluid is pressurized by pump and is sent to secondary line through cut valve 2. At the same time, pressurized brake fluid is supplied to rear LH wheel caliper through ABS IN valve.

When ABS operation starts (when pressure holds)

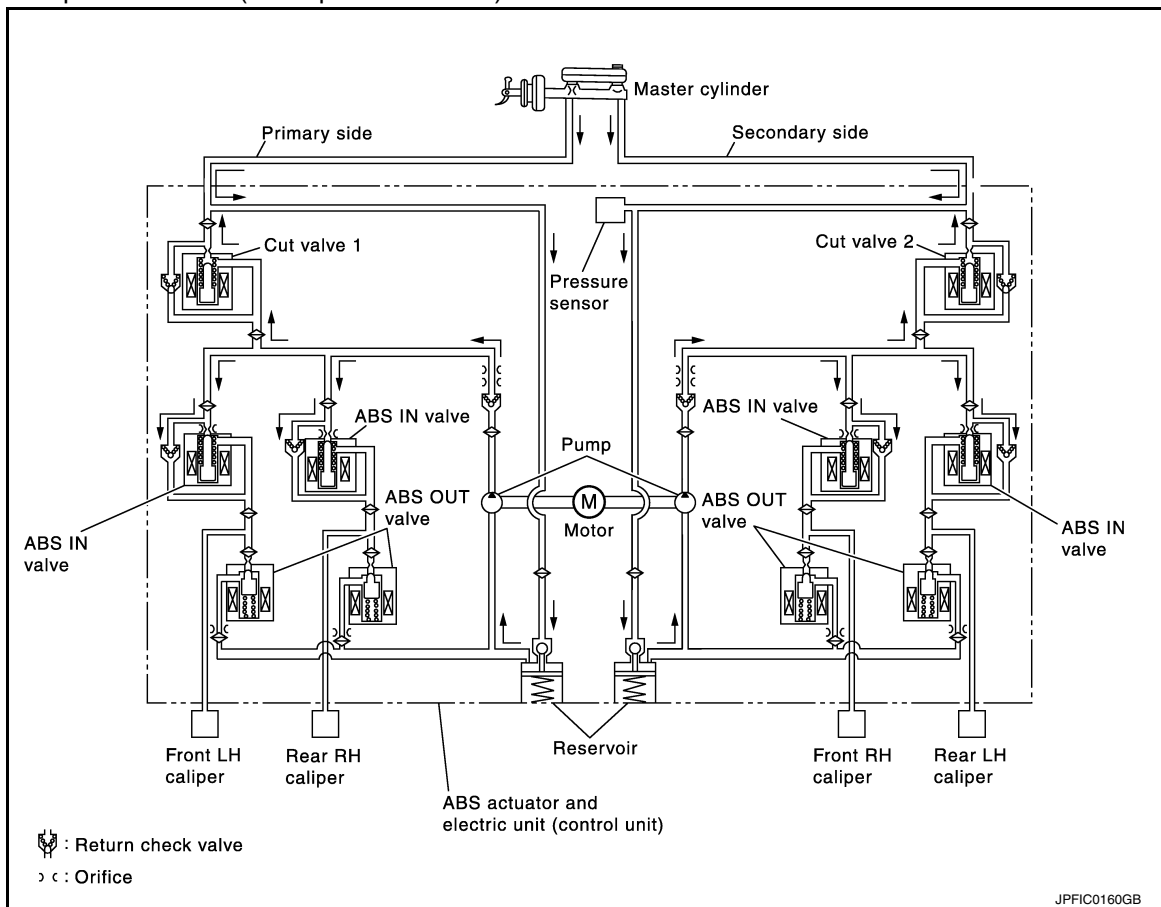

Name	Not activated	When pressure holds
Cut valve 1	Power supply is not supplied (open)	Power supply is not supplied (open)
Cut valve 2	Power supply is not supplied (open)	Power supply is not supplied (open)
ABS IN valve	Power supply is not supplied (open)	Power supply is supplied (close)
ABS OUT valve	Power supply is not supplied (close)	Power supply is not supplied (close)
Each caliper (fluid pressure)	—	Pressure holds

When front RH wheel caliper pressure holds

- Motor is activated. Brake fluid is pressurized by pump and is sent to secondary line through cut valve 2. At the same time because ABS IN valve and ABS OUT valve are closed, fluid pressure holds.

When front LH wheel caliper pressure holds

- Motor is activated. Brake fluid is pressurized by pump and is sent to primary line through cut valve 1. At the same time because ABS IN valve and ABS OUT valve are closed, fluid pressure holds.

SYSTEM

[WITH ICC]

< SYSTEM DESCRIPTION >

When rear RH wheel caliper pressure holds

- Motor is activated. Brake fluid is pressurized by pump and is sent to primary line through cut valve 1. At the same time because ABS IN valve and ABS OUT valve are closed, fluid pressure holds.

When rear LH wheel caliper pressure holds

- Motor is activated. Brake fluid is pressurized by pump and is sent to secondary line through cut valve 2. At the same time because ABS IN valve and ABS OUT valve are closed, fluid pressure holds.

ABS is in operation (when pressure decreases)

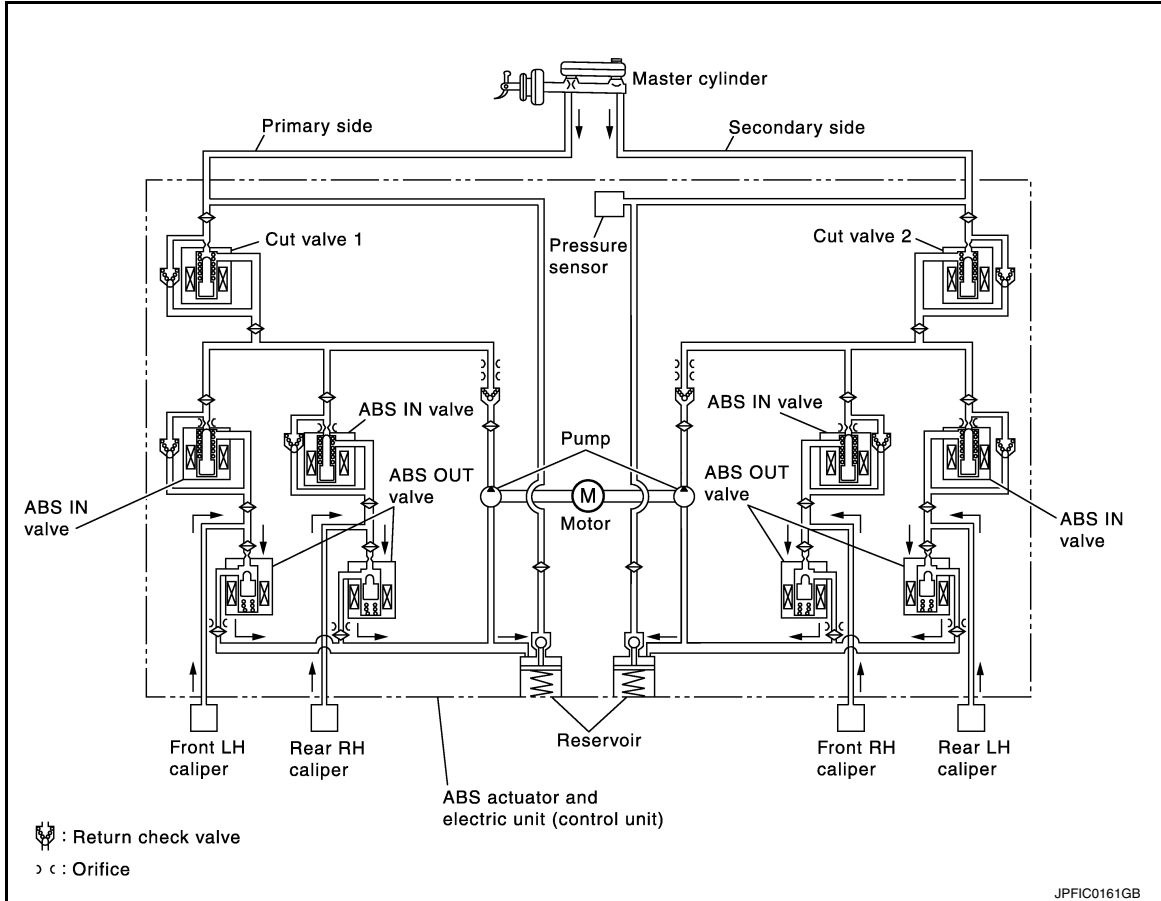

Name	Not activated	When pressure decreases
Cut valve 1	Power supply is not supplied (open)	Power supply is not supplied (open)
Cut valve 2	Power supply is not supplied (open)	Power supply is not supplied (open)
ABS IN valve	Power supply is not supplied (open)	Power supply is supplied (close)
ABS OUT valve	Power supply is not supplied (close)	Power supply is supplied (open)
Each caliper (fluid pressure)	—	Pressure decreases

When front RH wheel caliper pressure decreases

- Being supplied to reservoir through ABS OUT valve, the fluid pressure of brake caliper is decreased.

When front LH wheel caliper pressure decreases

- Being supplied to reservoir through ABS OUT valve, the fluid pressure of brake caliper is decreased.

When rear RH wheel caliper pressure decreases

- Being supplied to reservoir through ABS OUT valve, the fluid pressure of brake caliper is decreased.

When rear LH wheel caliper pressure decreases

- Being supplied to reservoir through ABS OUT valve, the fluid pressure of brake caliper is decreased.

Component Parts and Function

SYSTEM

< SYSTEM DESCRIPTION >

[WITH ICC]

Component	Function
Reservoir	Temporarily reserves the brake fluid drained from brake caliper, so that pressure efficiently decreases when decreasing pressure of brake caliper.
Pump	Returns the brake fluid reserved in reservoir to master cylinder by reducing pressure.
Motor	Drives the pump according to signals from control unit.
ABS IN valve	Switches the fluid pressure line to increase or hold according to signals from control unit.
ABS OUT valve	Switches the fluid pressure line to increase, hold or decrease according to signals from control unit.
Return check valve	Returns the brake fluid from brake caliper to master cylinder by bypassing orifice of each valve when brake is released.
Cut valve 1 Cut valve 2	Performs the duty control of fluid pressure increased by pump according to signals from control unit.
Pressure sensor	Detects the brake pedal operation amount.

VALVE OPERATION (OTHER THAN ABS AND EBD)

Each valve is operated and fluid pressure of brake caliper is controlled.

NOTE:

There is no operation to hold and increase pressure for functions other than ABS and EBD.

When pressure increases

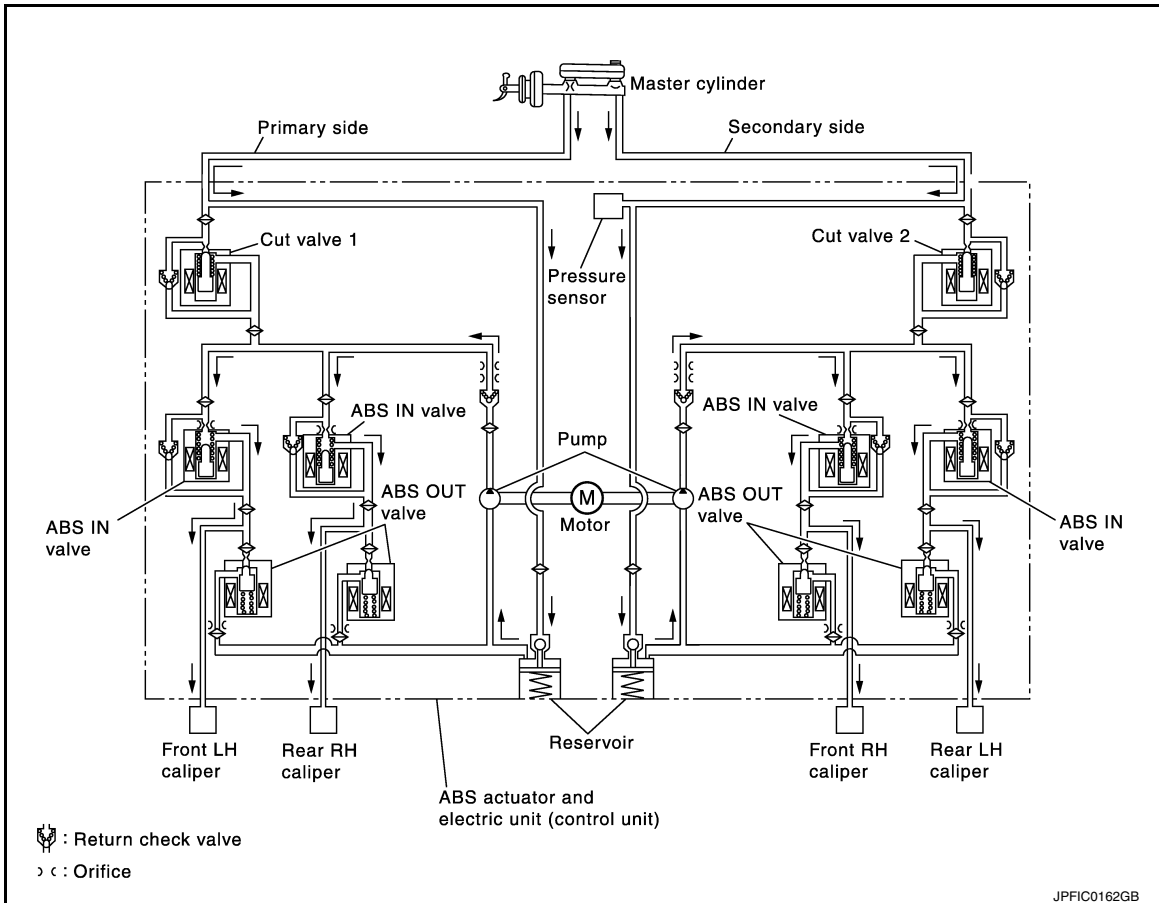

SYSTEM

< SYSTEM DESCRIPTION >

[WITH ICC]

Name	Not activated	When Pressure Increases
Cut valve 1	Power supply is not supplied (open)	Wheel other than the one that the pressure is to be increased: Power supply is not supplied (open) Only wheel that the pressure is to be increased: Power supply is supplied (close)
Cut valve 2	Power supply is not supplied (open)	Wheel other than the one that the pressure is to be increased: Power supply is not supplied (open) Only wheel that the pressure is to be increased: Power supply is supplied (close)
ABS IN valve	Power supply is not supplied (open)	Wheel other than the one that the pressure is to be increased: Power supply is supplied (close) Only wheel that the pressure is to be increased: Power supply is not supplied (open)
ABS OUT valve	Power supply is not supplied (close)	Power supply is not supplied (close)
Each caliper (fluid pressure)	—	Pressure increases

When front RH wheel caliper pressure increases

- Motor is activated. Brake fluid from pump is supplied to front RH wheel caliper through ABS IN valve. For other wheels, ABS IN valve is closed and brake fluid is not supplied to caliper.

When front LH wheel caliper pressure increases

- Motor is activated. Brake fluid from pump is supplied to front LH wheel caliper through ABS IN valve. For other wheels, ABS IN valve is closed and brake fluid is not supplied to caliper.

When rear RH wheel caliper pressure increases

- Motor is activated. Brake fluid from pump is supplied to rear RH wheel caliper through ABS IN valve. For other wheels, ABS IN valve is closed and brake fluid is not supplied to caliper.

When rear LH wheel caliper pressure increases

- Motor is activated. Brake fluid from pump is supplied to rear LH wheel caliper through ABS IN valve. For other wheels, ABS IN valve is closed and brake fluid is not supplied to caliper.

SYSTEM

[WITH ICC]

< SYSTEM DESCRIPTION >

Released

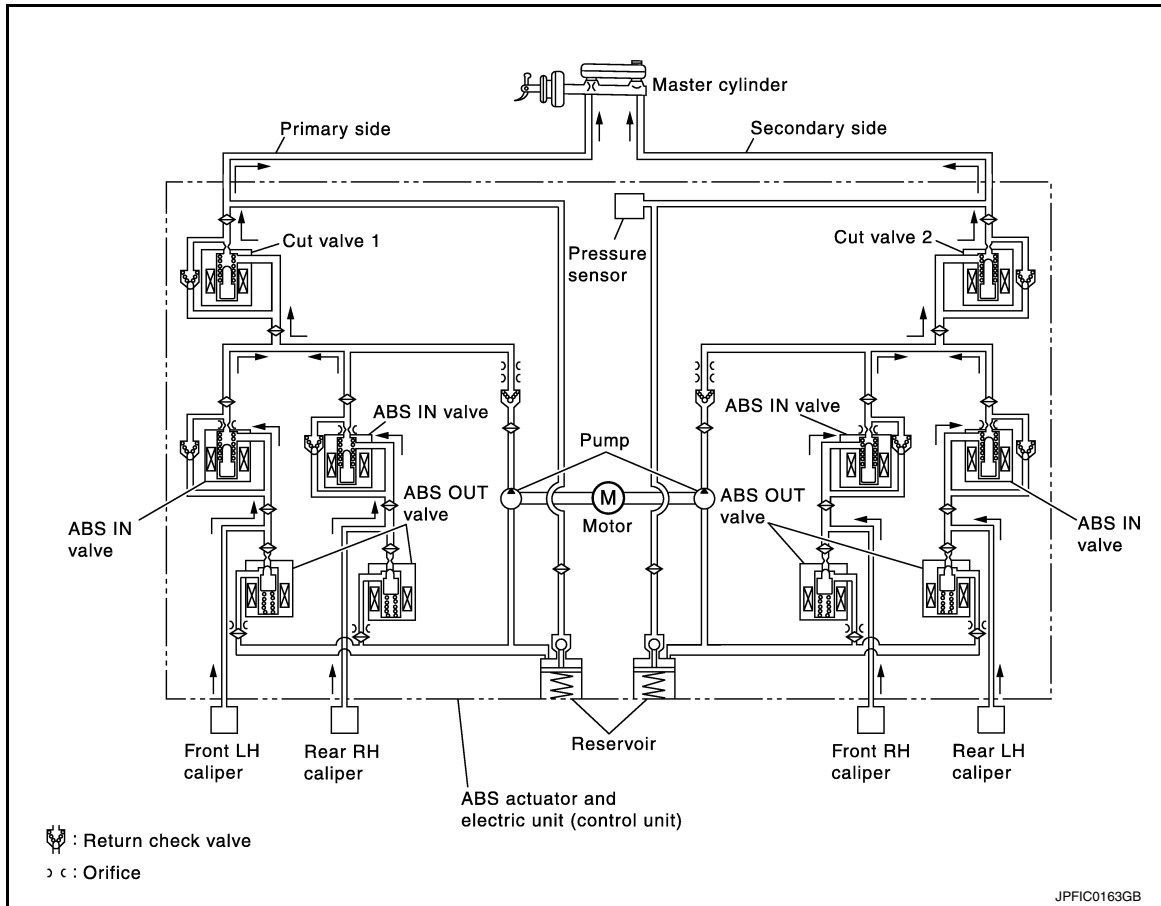

Name	Not activated	When pressure decreases
Cut valve 1	Power supply is not supplied (open)	Power supply is not supplied (open)
Cut valve 2	Power supply is not supplied (open)	Power supply is not supplied (open)
ABS IN valve	Power supply is not supplied (open)	Power supply is not supplied (open)
ABS OUT valve	Power supply is not supplied (close)	Power supply is supplied (open)
Each caliper (fluid pressure)	—	Pressure decreases

When front RH wheel caliper pressure decreases

- Being returned to master cylinder through ABS IN valve, fluid pressure of brake caliper is decreased.

When front LH wheel caliper pressure decreases

- Being returned to master cylinder through ABS IN valve, fluid pressure of brake caliper is decreased.

When rear RH wheel caliper pressure decreases

- Being returned to master cylinder through ABS IN valve, fluid pressure of brake caliper is decreased.

When rear LH wheel caliper pressure decreases

- Being returned to master cylinder through ABS IN valve, fluid pressure of brake caliper is decreased.

Component Parts and Function

Component	Function
Reservoir	Temporarily reserves the brake fluid drained from brake caliper so that pressure efficiently decreases when decreasing pressure of brake caliper.
Pump	Returns the brake fluid reserved in reservoir to master cylinder by reducing pressure.
Motor	Drives the pump according to signals from control unit.
ABS IN valve	Switches the fluid pressure line to increase or hold according to signals from control unit.

SYSTEM

[WITH ICC]

< SYSTEM DESCRIPTION >

Component	Function
ABS OUT valve	Switches the fluid pressure line to increase, hold or decrease according to signals from control unit.
Return check valve	Returns the brake fluid from brake caliper to master cylinder by bypassing orifice of each valve when brake is released.
Cut valve 1 Cut valve 2	Performs the duty control of fluid pressure increased by pump according to signals from control unit.
Pressure sensor	Detects the brake pedal operation amount.

CONDITION TO TURN ON THE WARNING LAMP

Turns ON when ignition switch turns ON and turns OFF when the system is normal for bulb check purposes.

Condition (status)	ABS warning lamp	Brake warning lamp	FEB warning lamp	VDC warning lamp
Ignition switch OFF	OFF	OFF	OFF	OFF
For approx. 1 second after the ignition switch is turned ON	ON	ON	ON	ON
Approx. 2 seconds after ignition switch is turned ON (when the system is in normal operation)	OFF	OFF	OFF	OFF
After engine starts	OFF	OFF	OFF	OFF
When brake fluid is less than the specified level (brake fluid level switch ON)	OFF	ON	OFF	OFF
When parking brake operates (parking brake switch ON)	OFF	ON	OFF	OFF
VDC function is malfunctioning	OFF	OFF	OFF	ON
TCS function is malfunctioning	OFF	OFF	OFF	ON
ABS function is malfunctioning	ON	OFF	OFF	ON
EBD function is malfunctioning	ON	ON	OFF	ON
FEB function is malfunctioning	OFF	OFF	ON	OFF
Brake assist function is malfunctioning	OFF	OFF	OFF	ON
Hill start assist function is malfunctioning	OFF	OFF	OFF	ON
Brake force distribution function is malfunctioning	OFF	OFF	OFF	ON
When brake booster vacuum decreases	OFF	ON	OFF	OFF
When vacuum sensor is malfunctioning	OFF	ON	OFF	OFF
VDC function is operating	OFF	OFF	OFF	Blinking
TCS function is operating	OFF	OFF	OFF	Blinking
ABS function is operating	OFF	OFF	OFF	OFF
EBD function is operating	OFF	OFF	OFF	OFF
FEB function is operating	OFF	OFF	Blinking	OFF
Brake assist function is operating	OFF	OFF	OFF	OFF
Hill start assist function is operating	OFF	OFF	OFF	OFF

CONDITION TO TURN ON THE INDICATOR LAMP

VDC OFF indicator lamp

- Turns ON when VDC function and TCS function are switched to non-operational status (OFF) by VDC OFF switch.
- Turns ON when ignition switch turns ON and turns OFF when the system is normal for bulb check purposes.

Condition (status)	VDC OFF indicator lamp
Ignition switch OFF	OFF
For approx. 1 second after the ignition switch is turned ON	ON

SYSTEM

< SYSTEM DESCRIPTION >

[WITH ICC]

Condition (status)	VDC OFF indicator lamp
Approx. 1 second after ignition switch is turned ON (when the system is in normal operation).	OFF
When VDC OFF switch is ON (VDC function TCS function are OFF)	ON

Fail-Safe

INFOID:000000012894533

VDC FUNCTION, TCS FUNCTION, BRAKE ASSIST FUNCTION and HILL START ASSIST FUNCTION

VDC warning lamp in combination meter turn ON when a malfunction occurs in system [ABS actuator and electric unit (control unit)]. The control is suspended for VDC function, TCS function, brake assist function and hill start assist function. The vehicle status becomes the same as models without VDC function, TCS function, brake assist function and hill start assist function. However, ABS function and EBD function are operated normally.

ABS FUNCTION

ABS warning lamp and VDC warning lamp in combination meter turn ON when a malfunction occurs in system [ABS actuator and electric unit (control unit)]. The control is suspended for VDC function, TCS function, ABS function, Brake assist function, hill start assist function and brake force distribution function. The vehicle status becomes the same as models without VDC function, TCS function, ABS function and hill start assist function. However, EBD function is operated normally.

NOTE:

ABS self-diagnosis sound may be heard the same as in the normal condition, because self-diagnosis is performed when ignition switch turns ON and when vehicle initially starts.

EBD FUNCTION

ABS warning lamp, brake warning lamp and VDC warning lamp in combination meter turn ON when a malfunction occurs in system [ABS actuator and electric unit (control unit)]. The control is suspended for VDC function, TCS function, ABS function, EBD function, brake assist function and hill start assist function. The vehicle status becomes the same as models without VDC function, TCS function, ABS function, EBD function, brake assist function and hill start assist function.

DTC	Fail-safe condition
C1101	The following functions are suspended: <ul style="list-style-type: none"> • VDC function • TCS function • ABS function • EBD function (only when both rear wheels are malfunctioning) • Brake assist function • Hill start assist function
C1102	
C1103	
C1104	
C1105	
C1106	
C1107	
C1108	
C1109	The following functions are suspended: <ul style="list-style-type: none"> • VDC function • TCS function • ABS function • EBD function • Brake assist function • Hill start assist function
C1111	
C1113	The following functions are suspended: <ul style="list-style-type: none"> • VDC function • TCS function • ABS function • Brake assist function • Hill start assist function
C1115	
C1116	The following functions are suspended: <ul style="list-style-type: none"> • VDC function • TCS function • ABS function • Brake assist function • Hill start assist function

SYSTEM

< SYSTEM DESCRIPTION >

[WITH ICC]

DTC	Fail-safe condition
C1120	The following functions are suspended: <ul style="list-style-type: none"> • VDC function • TCS function • ABS function • EBD function • Brake assist function • Hill start assist function
C1121	
C1122	
C1123	
C1124	
C1125	
C1126	
C1127	
C1130	The following functions are suspended: <ul style="list-style-type: none"> • VDC function • TCS function • Hill start assist function
C1140	The following functions are suspended: <ul style="list-style-type: none"> • VDC function • TCS function • ABS function • EBD function • Brake assist function • Hill start assist function
C1142	The following functions are suspended: <ul style="list-style-type: none"> • VDC function • TCS function • Brake assist function • Hill start assist function
C1143	The following functions are suspended: <ul style="list-style-type: none"> • VDC function • TCS function • Hill start assist function
C1144	
C1145	The following functions are suspended: <ul style="list-style-type: none"> • VDC function • TCS function • ABS function • Brake assist function • Hill start assist function
C1146	
C1155	The following functions are suspended: <ul style="list-style-type: none"> • VDC function • TCS function • Brake assist function • Hill start assist function
C1160	The following functions are suspended: <ul style="list-style-type: none"> • VDC function • TCS function • ABS function • Brake assist function • Hill start assist function
C1164	The following functions are suspended: <ul style="list-style-type: none"> • VDC function • TCS function • ABS function • EBD function • Brake assist function • Hill start assist function
C1165	
C1170	The following functions are suspended: <ul style="list-style-type: none"> • VDC function • TCS function • ABS function • Brake assist function • Hill start assist function

SYSTEM

< SYSTEM DESCRIPTION >

[WITH ICC]

DTC	Fail-safe condition
C1197	Electrical vacuum assistance of brake booster is suspended.
C1198	
C1199	
C119A	
U1000	The following functions are suspended: <ul style="list-style-type: none"> • VDC function • TCS function • Hill start assist function

VDC FUNCTION

VDC FUNCTION : System Description

INFOID:000000012894534

SYSTEM DIAGRAM

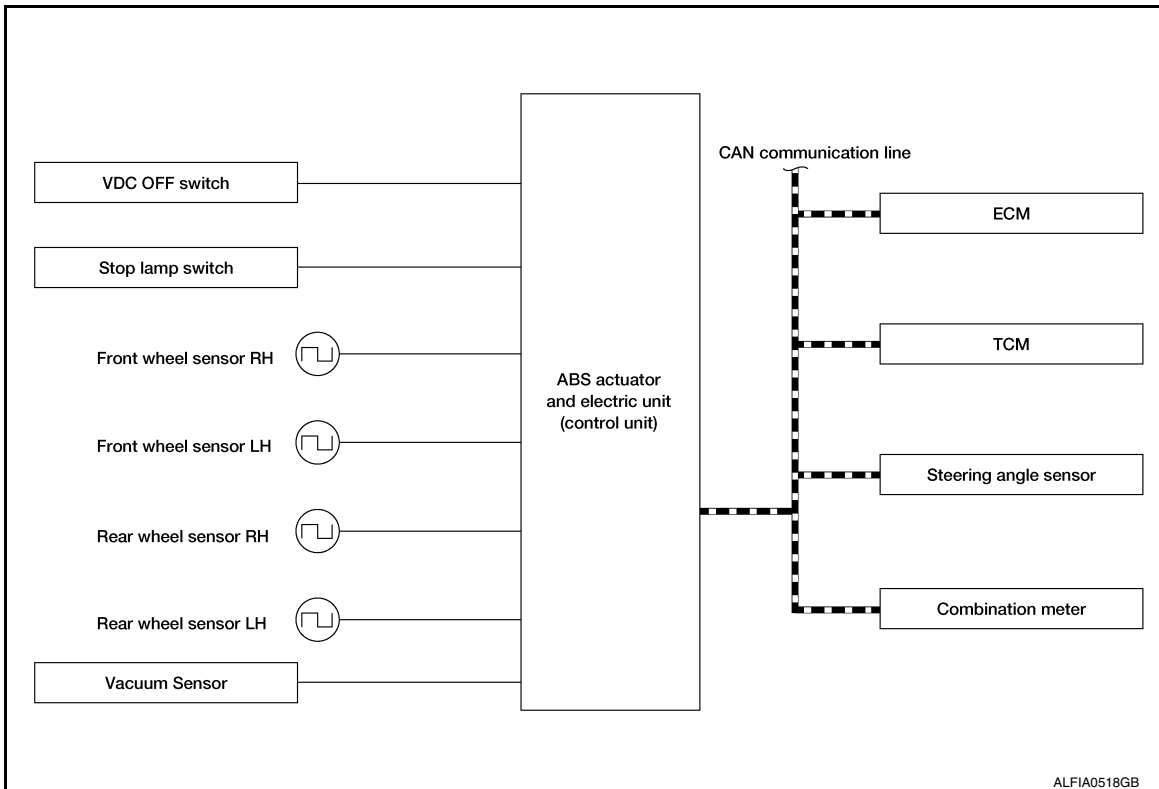

- Side slip or tail slip may occur while driving on a slippery road or intending urgent evasive driving. VDC function detects side slip status using each sensor when side slip or tail slip is about to occur and improves vehicle stability by brake control and engine output control during driving.
- In addition to ABS function, EBD function and TCS function, target side slip amount is calculated according to steering operation amount from steering angle sensor and brake operation amount from brake pressure sensor. By comparing this information with vehicle side slip amount that is calculated from information from yaw rate/side/decel G sensor and wheel sensor, vehicle driving conditions (conditions of understeer or oversteer) are judged and vehicle stability is improved by brake force control on all wheels and engine output control.

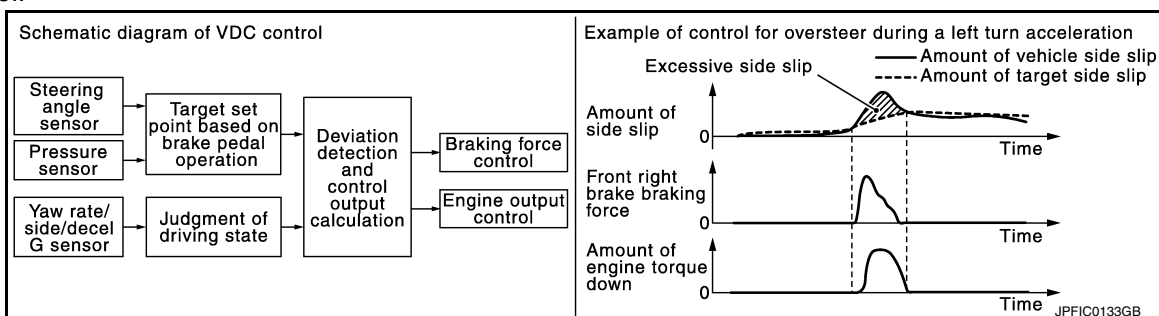

A
B
C
D
E
BRC
G
H
I
J
K
L
M
N
O
P

SYSTEM

[WITH ICC]

< SYSTEM DESCRIPTION >

- VDC function can be switched to non-operational status (OFF) by operating VDC OFF switch. In this case, VDC OFF indicator lamp turns ON.
- Control unit portion automatically improves driving stability by performing brake force control as well as engine output control, by transmitting drive signal to actuator portion according to difference between target side slip amount and vehicle side slip amount
- VDC warning lamp blinks while VDC function is in operation and indicates to the driver that the function is in operation.
- CONSULT can be used to diagnose the system diagnosis.
- Fail-safe function is adopted. When a malfunction occurs in VDC function, the control is suspended for VDC function, TCS function, brake assist function, hill start assist function and brake force distribution function. The vehicle status becomes the same as models without VDC function, TCS function, brake assist function and hill start assist function. However, ABS function and EBD function are operated normally. Refer to [BRC-47. "Fail-Safe"](#).

INPUT SIGNAL AND OUTPUT SIGNAL

Major signal transmission between each unit via communication lines is shown in the following table:

Component	Signal description
ECM	Mainly transmits the following signals to ABS actuator and electric unit (control unit) via CAN communication: <ul style="list-style-type: none"> • Accelerator pedal position signal • Engine speed signal • Engine torque signal Mainly receives the following signal from ABS actuator and electric unit (control unit) via CAN communication: <ul style="list-style-type: none"> • Engine torque request signal
TCM	Mainly transmits the following signal to ABS actuator and electric unit (control unit) via CAN communication: <ul style="list-style-type: none"> • Current gear position signal
Combination meter	Mainly receives the following signals from ABS actuator and electric unit (control unit) via CAN communication: <ul style="list-style-type: none"> • Brake fluid level switch signal • Parking brake switch signal Mainly receives the following signals from ABS actuator and electric unit (control unit) via CAN communication: <ul style="list-style-type: none"> • VDC warning lamp signal • VDC OFF indicator lamp signal
Steering angle sensor	Mainly transmits the following signals to ABS actuator and electric unit (control unit) via CAN communication: <ul style="list-style-type: none"> • Steering angle sensor signal • Steering angle sensor malfunction signal

OPERATION CHARACTERISTICS

VDC Function That Prevents Oversteer Tendency

- During cornering, brake force (brake fluid pressure) is applied on front wheel and rear wheel on the outer side of turn. Momentum directing towards the outer side of turn is generated. Oversteer is prevented.

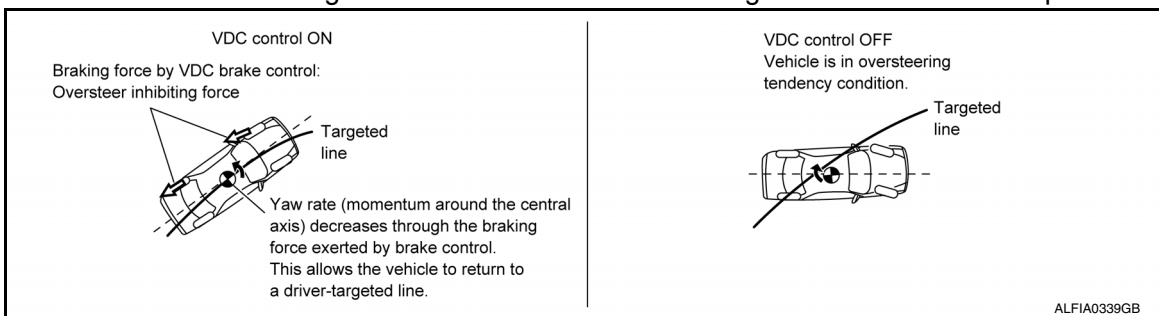

SYSTEM

[WITH ICC]

< SYSTEM DESCRIPTION >

- Changing driving lane on a slippery road when oversteer tendency is judged large, engine output is controlled as well as brake force (brake fluid pressure) of 4 wheels. Oversteer tendency decreases.

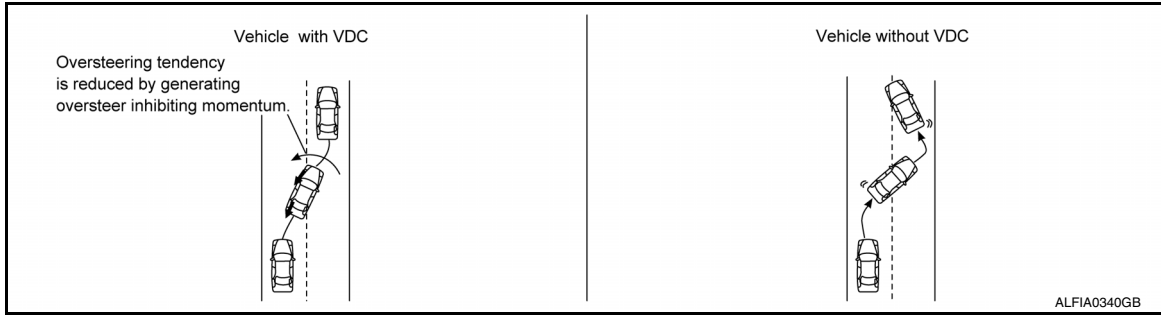

VDC Function That Prevents Understeer Tendency

- During cornering, brake force (brake fluid pressure) is applied on front wheel and rear wheel on the inner side of turn. Momentum directing towards the inner side of turn is generated. Understeer is prevented.

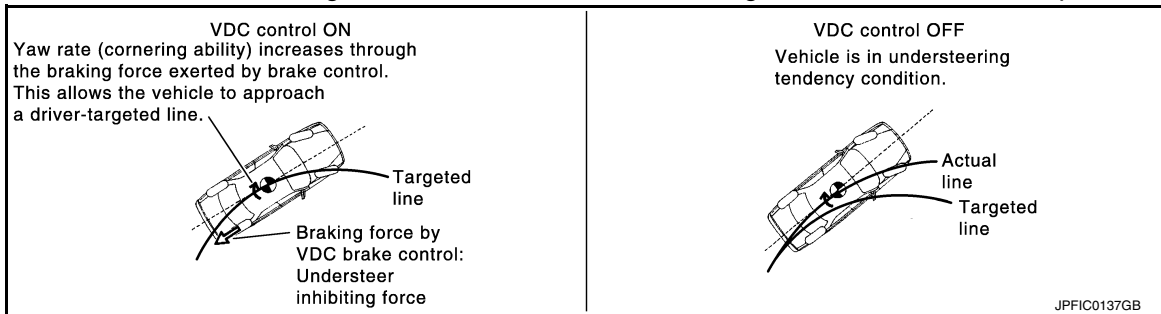

- Applying braking during cornering on a slippery road when understeer tendency is judged large, engine output is controlled as well as brake force (brake fluid pressure) of four wheels. Understeer tendency decreases.

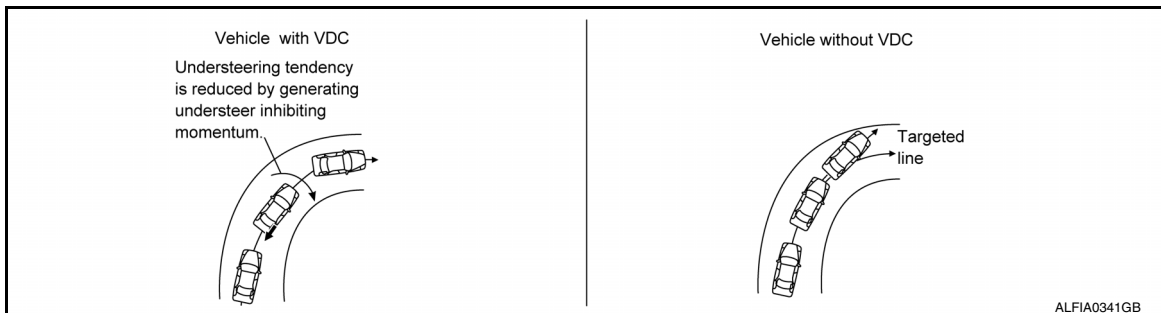

TCS FUNCTION

A
B
C
D
E
G
H
I
J
K
L
M
N
O
P

BRC

TCS FUNCTION : System Description

INFOID:000000012894535

SYSTEM DIAGRAM

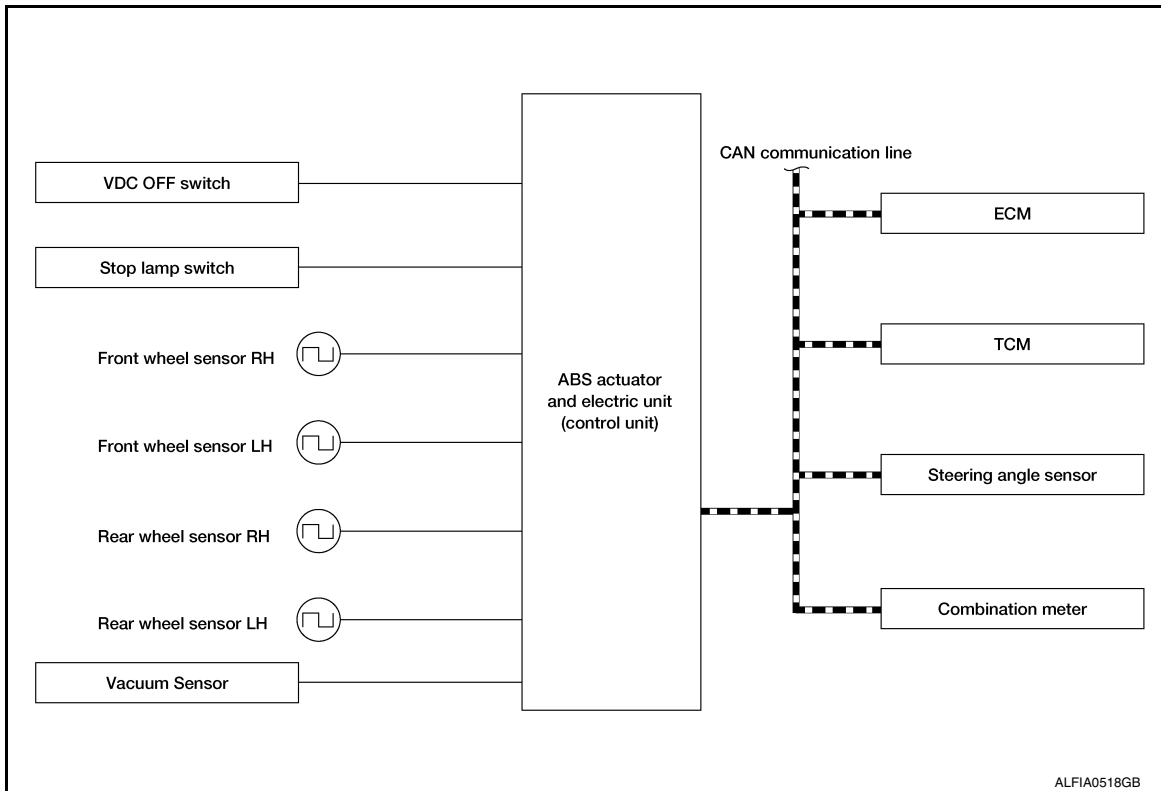

- Wheel spin status of drive wheel is detected by wheel sensor of 4 wheels. Engine output and transmission shift status are controlled so that slip rate of drive wheels is in appropriate level. When wheel spin occurs on drive wheel, ABS actuator and electric unit (control unit) performs brake force control of LH and RH drive wheels (applies brake force by increasing brake fluid pressure of drive wheel) and decreases engine torque by engine torque control. Wheel spin amount decreases. Engine torque is controlled to appropriate level.
- TCS function can be switched to non-operational status (OFF) by operating VDC OFF switch. In this case, VDC OFF indicator lamp turns ON.
- VDC warning lamp blinks while TCS function is in operation and indicates to the driver that the function is in operation.
- CONSULT can be used to diagnose the system diagnosis.
- Fail-safe function is adopted. When a malfunction occurs in TCS function, the control is suspended for VDC function, TCS function, brake assist function and hill start assist function. The vehicle status becomes the same as models without VDC function, TCS function, brake assist function and hill start assist function. However, ABS function and EBD function are operated normally. Refer to [BRC-47, "Fail-Safe"](#).

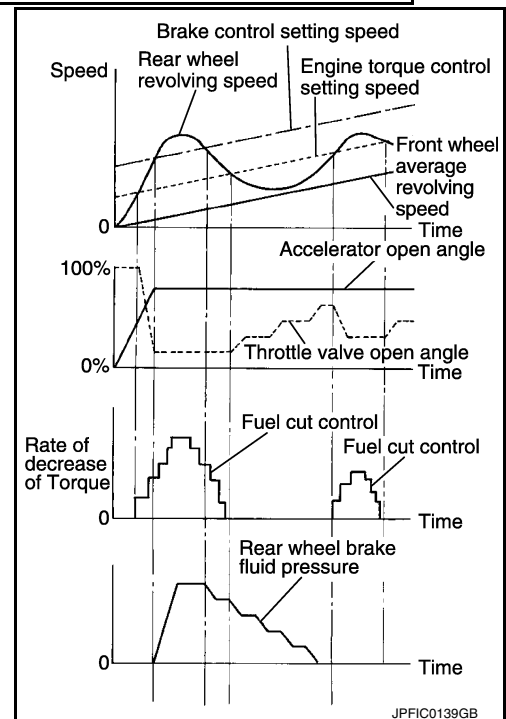

SYSTEM

< SYSTEM DESCRIPTION >

[WITH ICC]

SYSTEM DIAGRAM

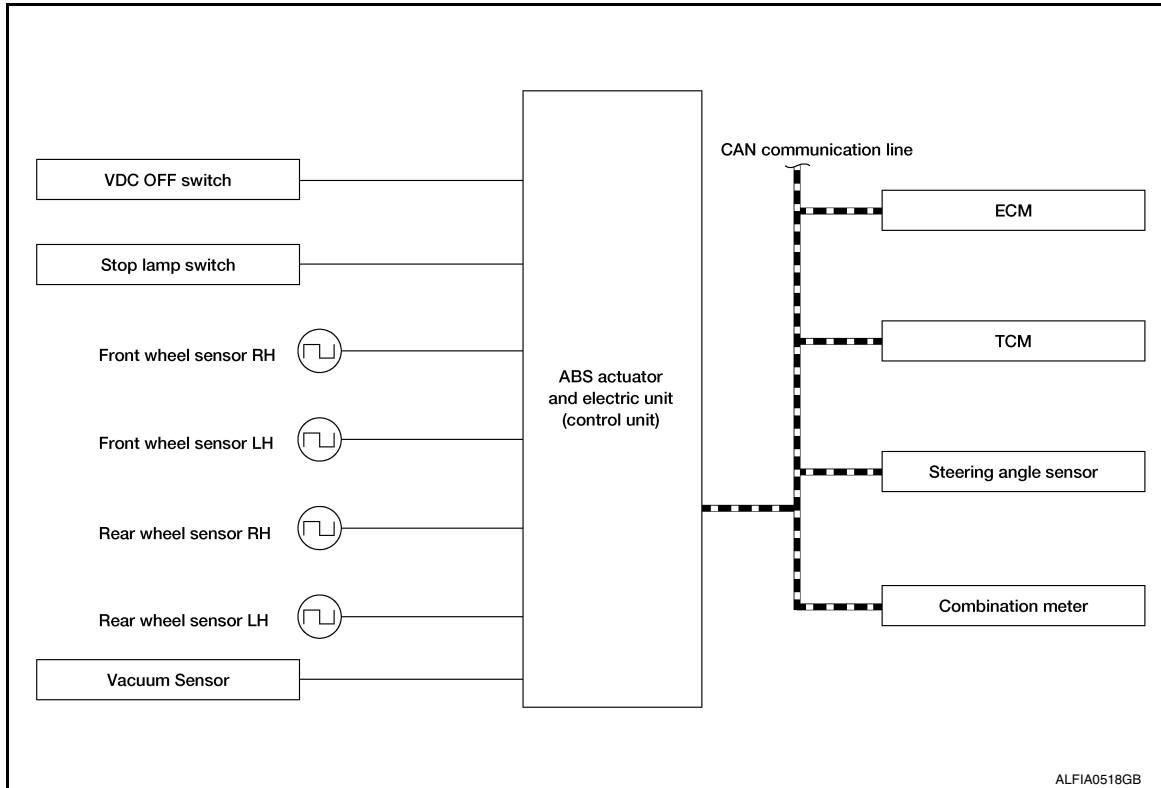

INPUT SIGNAL AND OUTPUT SIGNAL

Major signal transmission between each unit via communication lines is shown in the following table:

Component	Signal description
ECM	<p>Mainly transmits the following signals to ABS actuator and electric unit (control unit) via CAN communication:</p> <ul style="list-style-type: none"> • Accelerator pedal position signal • Engine speed signal • Engine torque signal <p>Mainly receives the following signal from ABS actuator and electric unit (control unit) via CAN communication:</p> <ul style="list-style-type: none"> • Engine torque request signal
TCM	<p>Mainly transmits the following signal to ABS actuator and electric unit (control unit) via CAN communication:</p> <ul style="list-style-type: none"> • Current gear position signal
Combination meter	<p>Mainly receives the following signals from ABS actuator and electric unit (control unit) via CAN communication:</p> <ul style="list-style-type: none"> • Brake fluid level switch signal • Parking brake switch signal <p>Mainly receives the following signals from ABS actuator and electric unit (control unit) via CAN communication:</p> <ul style="list-style-type: none"> • VDC warning lamp signal • VDC OFF indicator lamp signal
Steering angle sensor	<p>Mainly transmits the following signals to ABS actuator and electric unit (control unit) via CAN communication:</p> <ul style="list-style-type: none"> • Steering angle sensor signal • Steering angle sensor malfunction signal

ABS FUNCTION

ABS FUNCTION : System Description

INFOID:000000012894536

SYSTEM DIAGRAM

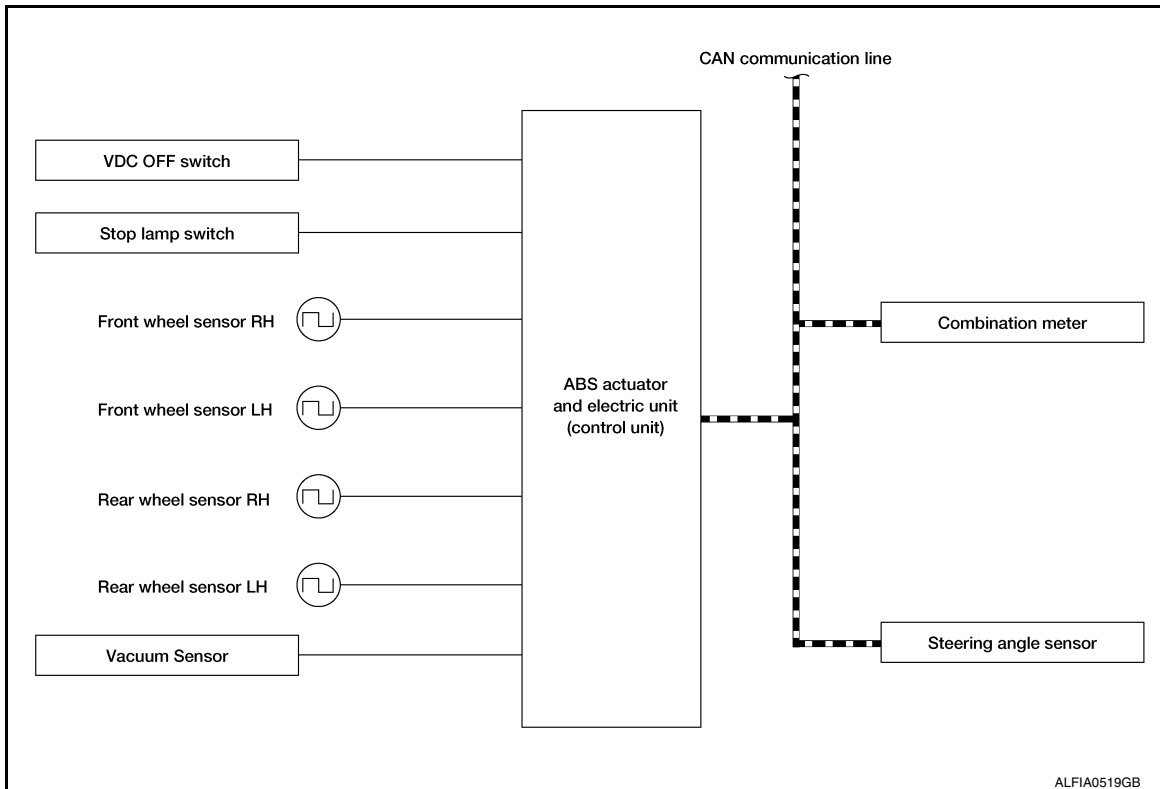

- By preventing wheel lock through brake force (brake fluid pressure) control that is electronically controlled by detecting wheel speed during braking, stability during emergency braking is improved so that obstacles can be easily bypassed by steering operation.
- During braking, control units calculate wheel speed and pseudo-vehicle speed and transmits pressure increase, hold or decrease signals to actuator portion according to wheel slip status.
- The following effects are obtained by preventing wheel lock during braking:
 - Vehicle tail slip is prevented during braking when driving straight.
 - Understeer and oversteer tendencies are moderated during braking driving on a corner.
 - Obstacles may be easily bypassed by steering operation during braking.
- CONSULT can be used to diagnose the system diagnosis.
- Fail-safe function is adopted. When a malfunction occurs in ABS function, the control is suspended for VDC function, TCS function, ABS function and hill start assist function. The vehicle status becomes the same as models without VDC function, TCS function, ABS function, brake assist function and hill start assist function. However, EBD function is operated normally. Refer to [BRC-225](#), "Fail-Safe".

NOTE:

- ABS has the characteristics as described here. This is not a device that helps reckless driving.
- To stop vehicle efficiently, ABS does not operate and ordinary brake operates at low speed [approx. 10 km/h (6 MPH) or less, but differs subject to road conditions].
- Self-diagnosis is performed immediately after engine starts and when vehicle initially is driven [by vehicle speed approx. 15 km/h (9 MPH)]. Motor sounds are generated during self-diagnosis. In addition, brake pedal may be feel heavy when depressing brake pedal lightly. These symptoms are not malfunctions.

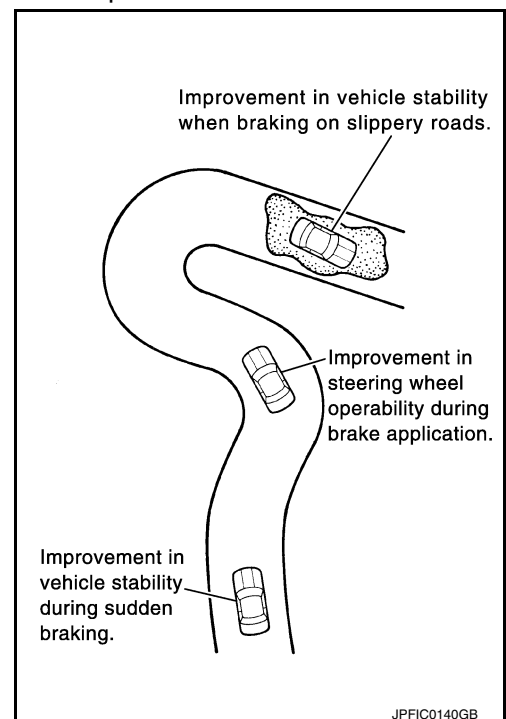

SYSTEM

[WITH ICC]

< SYSTEM DESCRIPTION >

INPUT SIGNAL AND OUTPUT SIGNAL

Major signal transmission between each unit via communication lines is shown in the following table:

Component	Signal description
Combination meter	Mainly receives the following signals from ABS actuator and electric unit (control unit) via CAN communication: <ul style="list-style-type: none"> • Brake fluid level switch signal • Parking brake switch signal Mainly receives the following signals from ABS actuator and electric unit (control unit) via CAN communication: <ul style="list-style-type: none"> • ABS warning lamp signal • VDC warning lamp signal • VDC OFF indicator lamp signal
Steering angle sensor	Mainly transmits the following signals to ABS actuator and electric unit (control unit) via CAN communication: <ul style="list-style-type: none"> • Steering angle sensor signal • Steering angle sensor malfunction signal

EBD FUNCTION

EBD FUNCTION : System Description

INFOID:000000012894537

SYSTEM DIAGRAM

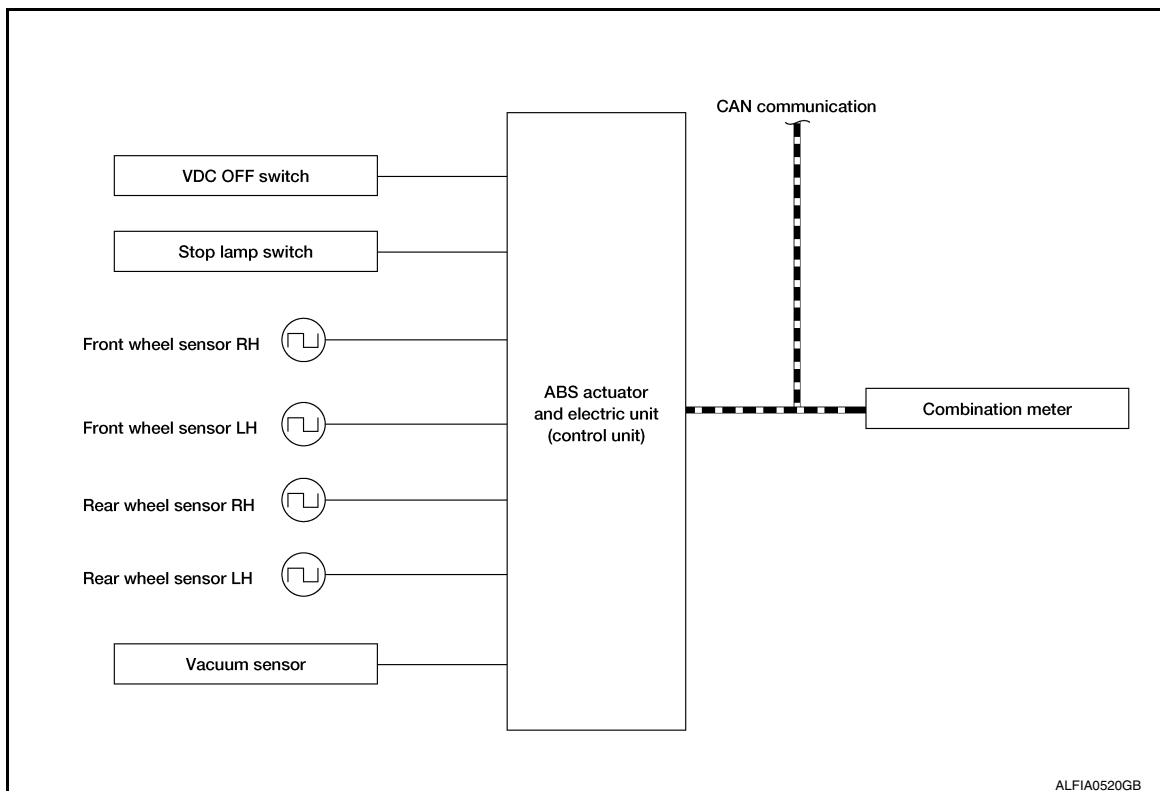

- By preventing rear wheel slip increase through rear wheel brake force (brake fluid pressure) control that is electronically controlled when slight slip on front and rear wheels is detected during braking, stability during braking is improved.

SYSTEM

[WITH ICC]

< SYSTEM DESCRIPTION >

- EBD function is expanded and developed from conventional ABS function and corrects rear wheel brake force to appropriate level by electronic control according to load weight (number of passengers).

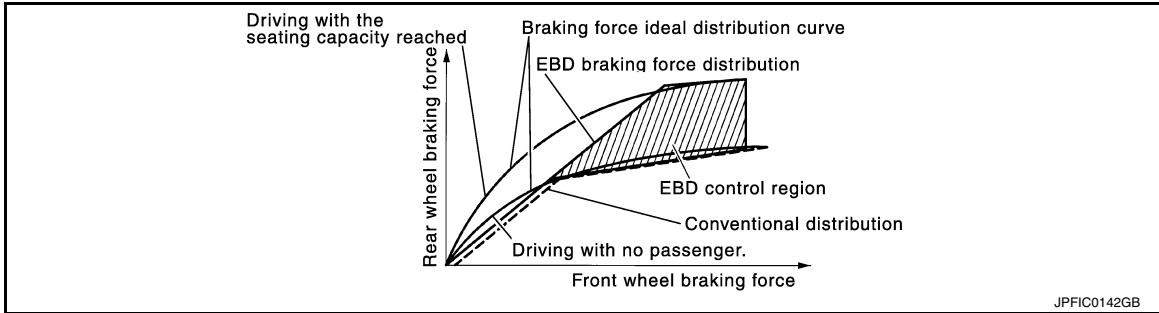

- During braking, control unit portion compares slight slip on front and rear wheels by wheel speed sensor signal, transmits drive signal to actuator portion when rear wheel slip exceeds front wheel slip for the specified value or more, and controls rear wheel brake force (brake fluid pressure) so that increase of rear wheel slip is prevented and slips on front wheel and rear wheel are nearly equalized. ABS control is applied when slip on each wheel increases and wheel speed is the threshold value of ABS control or less.
- CONSULT can be used to diagnose the system diagnosis.
- Fail-safe function is adopted. When a malfunction occurs in EBD function, the control is suspended for VDC function, TCS function, ABS function, EBD function, brake assist function and hill start assist function. The vehicle status becomes the same as models without VDC function, TCS function, ABS function, EBD function, brake assist function and hill start assist function. Refer to [BRC-225, "Fail-Safe"](#).

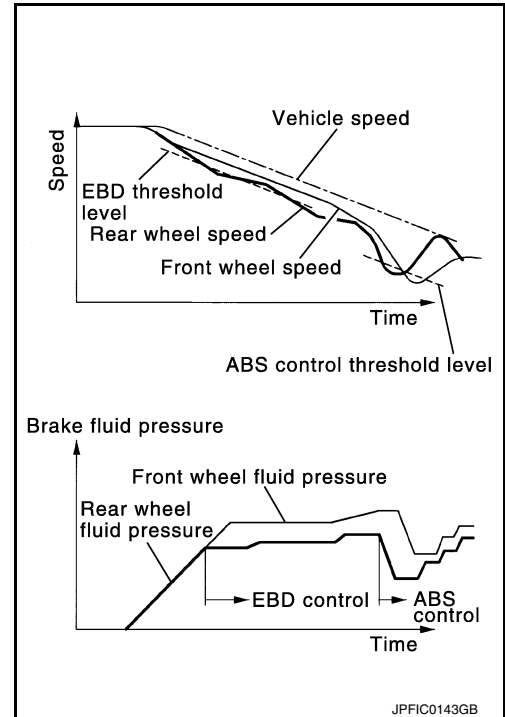

INPUT SIGNAL AND OUTPUT SIGNAL

Major signal transmission between each unit via communication lines is shown in the following table:

Component	Signal description
Combination meter	Mainly receives the following signals from ABS actuator and electric unit (control unit) via CAN communication: <ul style="list-style-type: none"> VDC warning lamp signal ABS warning lamp signal Brake warning lamp signal

BRAKE ASSIST (WITHOUT PREVIEW FUNCTION)

SYSTEM

< SYSTEM DESCRIPTION >

[WITH ICC]

BRAKE ASSIST (WITHOUT PREVIEW FUNCTION) : System Description INFOID:000000012894538

SYSTEM DIAGRAM

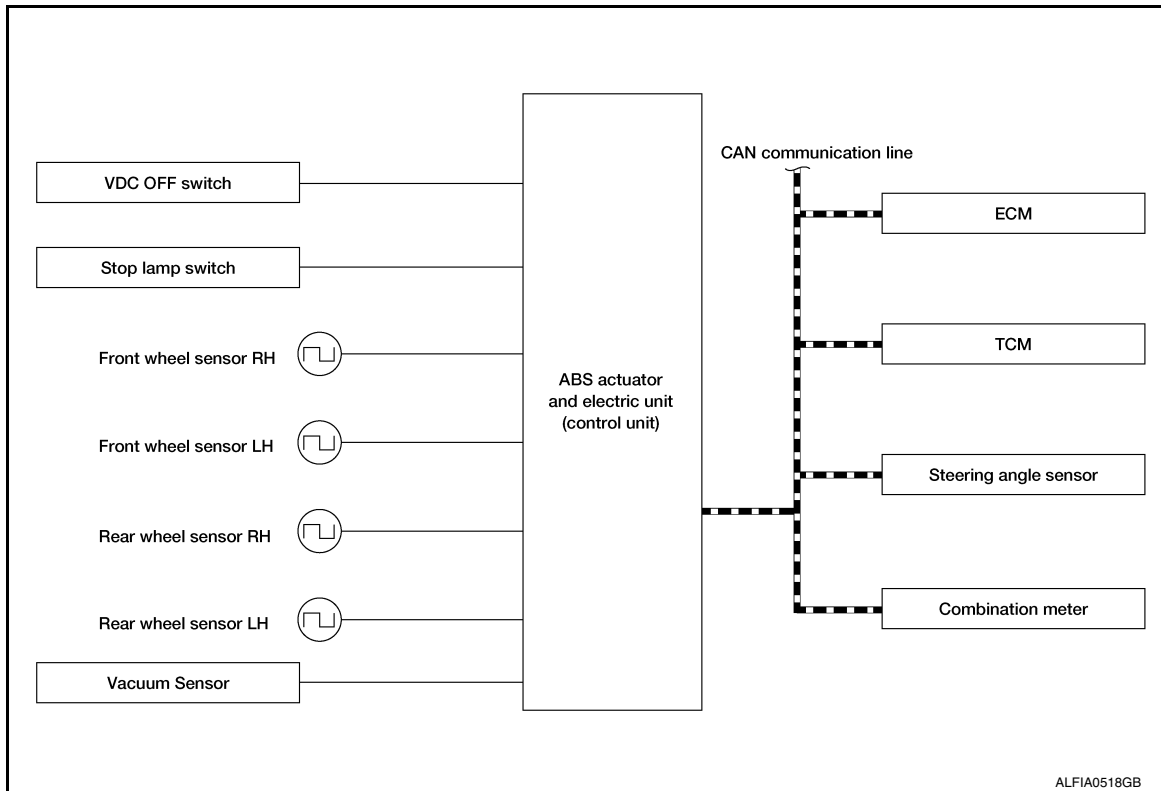

- When the driver brakes hard in an emergency, the stopping distance is reduced by increasing brake fluid pressure.
- Fail-safe function is adopted. When a malfunction occurs in brake assist function, the control is suspended for VDC function, TCS function, brake assist function and hill start assist function. The vehicle status becomes the same as models without VDC function, TCS function, brake assist function and hill start assist function. However, ABS function and EBD function are operated normally. Refer to [BRC-225, "Fail-Safe"](#).

INPUT SIGNAL AND OUTPUT SIGNAL

Major signal transmission between each unit via communication lines is shown in the following table:

Component	Signal description
ECM	<p>Mainly transmits the following signal to ABS actuator and electric unit (control unit) via CAN communication:</p> <ul style="list-style-type: none"> • Accelerator pedal position signal • Engine speed signal • Engine torque signal <p>Mainly receives the following signal from ABS actuator and electric unit (control unit) via CAN communication:</p> <ul style="list-style-type: none"> • Engine torque request signal
TCM	<p>Mainly transmits the following signal to ABS actuator and electric unit (control unit) via CAN communication:</p> <ul style="list-style-type: none"> • Current gear position signal

SYSTEM

< SYSTEM DESCRIPTION >

[WITH ICC]

Component	Signal description
Combination meter	Mainly receives the following signals from ABS actuator and electric unit (control unit) via CAN communication: <ul style="list-style-type: none"> • Brake fluid level switch signal • Parking brake switch signal Mainly receives the following signals from ABS actuator and electric unit (control unit) via CAN communication: <ul style="list-style-type: none"> • VDC warning lamp signal • VDC OFF indicator lamp signal
Steering angle sensor	Mainly transmits the following signals to ABS actuator and electric unit (control unit) via CAN communication: <ul style="list-style-type: none"> • Steering angle sensor signal • Steering angle sensor malfunction signal

hill start assist FUNCTION

hill start assist FUNCTION : System Description

INFOID:0000000012894539

SYSTEM DIAGRAM

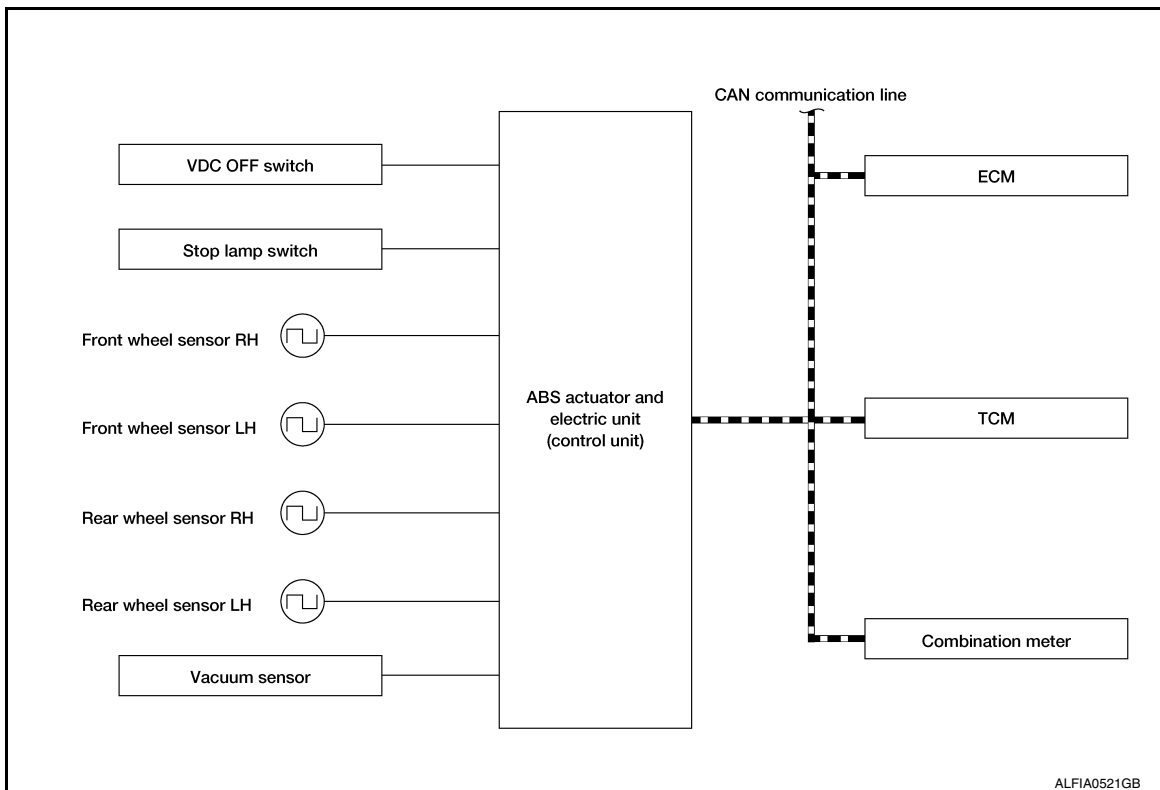

- This function maintains brake fluid pressure so that the vehicle does not move backward even if brake pedal is released to depress accelerator pedal to start the vehicle while it is stopped on an uphill slope by depressing brake pedal.
- This function operates when the vehicle is in stop status on a uphill slope of slope ratio 10% or more and selector lever is in a position other than P or N.
- Hill start assist function is only for the start aid. It maintains the brake fluid pressure for approximately 2 seconds after releasing the brake pedal and then decreases the pressure gradually. If the vehicle can start by the accelerator operation, the brake is released automatically and a smooth start can be performed.
- Fail-safe function is adopted. When a malfunction occurs in hill start assist function, the control is suspended for VDC function, TCS function, brake assist function and hill start assist function. The vehicle status becomes the same as models without VDC function, TCS function, brake assist function and hill start assist function. However, ABS function and EBD function are operated normally. Refer to [BRC-225, "Fail-Safe"](#).

INPUT SIGNAL AND OUTPUT SIGNAL

Major signal transmission between each unit via communication lines is shown in the following table:

SYSTEM

< SYSTEM DESCRIPTION >

[WITH ICC]

Component	Signal description
ECM	Mainly transmits the following signals to ABS actuator and electric unit (control unit) via CAN communication: <ul style="list-style-type: none"> • Accelerator pedal position signal • Engine speed signal • Engine torque signal Mainly receives the following signal from ABS actuator and electric unit (control unit) via CAN communication: <ul style="list-style-type: none"> • Engine torque request signal
TCM	Mainly transmits the following signal to ABS actuator and electric unit (control unit) via CAN communication: <ul style="list-style-type: none"> • Current gear position signal
Combination meter	Mainly receives the following signals from ABS actuator and electric unit (control unit) via CAN communication: <ul style="list-style-type: none"> • Brake fluid level switch signal • Parking brake switch signal Mainly receives the following signals from ABS actuator and electric unit (control unit) via CAN communication: <ul style="list-style-type: none"> • VDC warning lamp signal • VDC OFF indicator lamp signal

A
B
C
D
E
BRC

BRAKE ASSIST (WITH PREVIEW FUNCTION)

BRAKE ASSIST (WITH PREVIEW FUNCTION) : System Description-Forward Emergency Braking

INFOID:0000000012894540

SYSTEM DIAGRAM

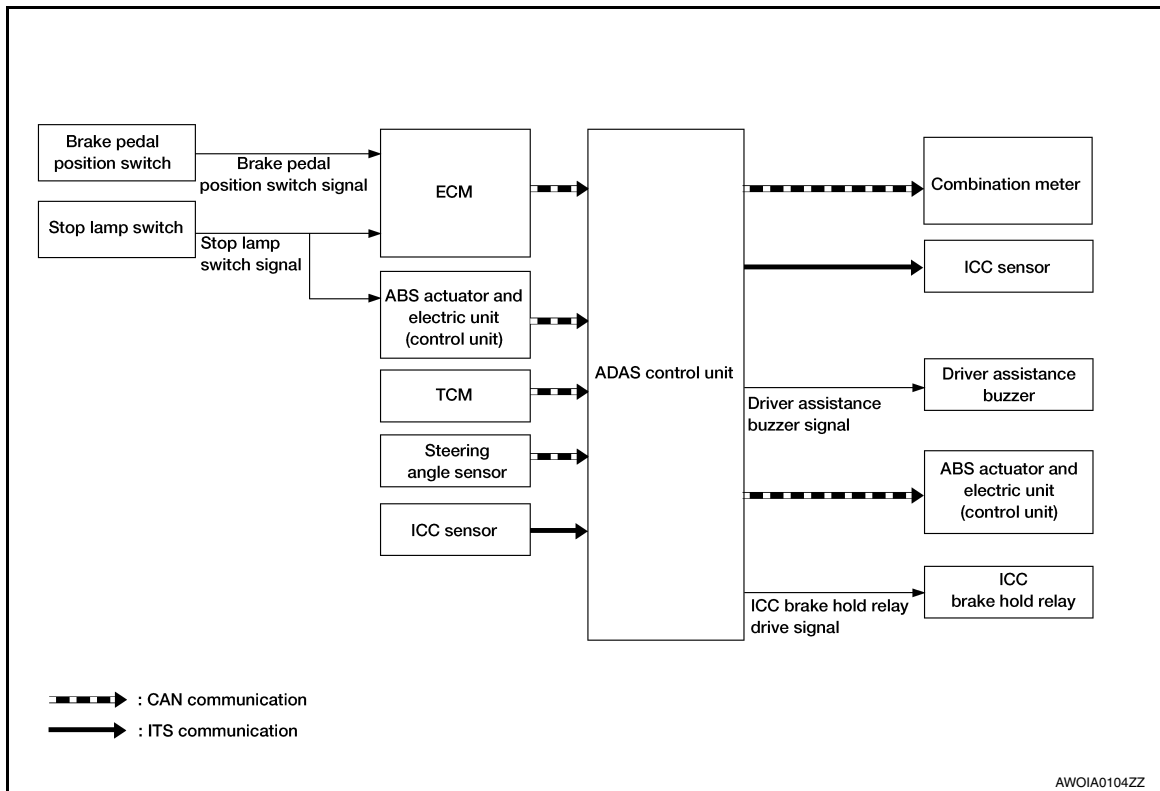

G
H
I
J
K
L
M
N
O
P

ADAS CONTROL UNIT INPUT/OUTPUT SIGNAL ITEM

Input Signal Item

SYSTEM

< SYSTEM DESCRIPTION >

[WITH ICC]

Transmit unit	Signal name		Description
ECM	CAN communication	Closed throttle position signal	Receives idle position state (ON/OFF)
		Accelerator pedal position signal	Receives accelerator pedal position (angle)
		Engine speed signal	Receives engine speed
		Stop lamp switch signal	Receives an operational state of the brake pedal
		Brake pedal position switch signal	Receives an operational state of the brake pedal
TCM	CAN communication	Input speed signal	Receives the number of revolutions of input shaft
		Current gear position signal	Receives a current gear position
		Shift position signal	Receives a selector lever position
		Output shaft revolution signal	Receives the number of revolutions of output shaft
ABS actuator and electric unit (control unit)	CAN communication	ABS malfunction signal	Receives a malfunction state of ABS
		ABS operation signal	Receives an operational state of ABS
		ABS warning lamp signal	Receives an ON/OFF state of ABS warning lamp
		TCS malfunction signal	Receives a malfunction state of TCS
		TCS operation signal	Receives an operational state of TCS
		VDC OFF switch signal	Receives an ON/OFF state of VDC
		VDC malfunction signal	Receives a malfunction state of VDC
		VDC operation signal	Receives an operational state of VDC
		Vehicle speed signal (ABS)	Receives wheel speeds of four wheels
		Yaw rate signal	Receives yaw rate acting on the vehicle
Steering angle sensor	CAN communication	Steering angle sensor malfunction signal	Receives a malfunction state of steering angle sensor
		Steering angle sensor signal	Receives the number of revolutions, turning direction of the steering wheel
		Steering angle speed signal	Receives the turning angle speed of the steering wheel
ICC sensor	ITS communication	ICC sensor signal	Receives detection results, such as the presence or absence of a leading vehicle and distance from the vehicle

Output Signal Item

Reception unit	Signal name		Description
ABS actuator and electric unit (control unit)	CAN communication	Brake fluid pressure control signal	Transmits a brake fluid pressure control signal to activates the brake
Combination meter	CAN communication	Meter display signal	Vehicle ahead detection indicator signal
			FEB/PFCW system display signal
			FEB warning signal
ICC sensor	ITS communication	Vehicle speed signal	Transmits a vehicle speed calculated by the ADAS control unit
		Steering angle sensor signal	Transmits a steering angle sensor signal received from the steering angle sensor
ICC brake hold relay	ICC brake hold relay drive signal		Activates the brake hold relay and turns ON the stop lamp

DESCRIPTION

- Forward emergency braking (FEB) system can assist the driver when there is a forward collision with the vehicle ahead in the traveling lane.

SYSTEM

< SYSTEM DESCRIPTION >

[WITH ICC]

- FEB system operate at speeds above approximately 5 km/h (3 mph)

FUNCTION DESCRIPTION

- The FEB system uses the ICC sensor to measure the distance to the vehicle ahead in the traveling lane.
- If there is a risk of collision, FEB issues a visual and audible warning signal to the combination meter via CAN communication.
- If the driver does not take action, FEB system applies braking command to ABS actuator and electric unit (control unit).
- If the risk of a collision becomes immanent, FEB system applies braking command to ABS actuator and electric unit (control unit) via CAN communication.

Operation Condition

- FEB is ON.
- Vehicle speed: approximately 5 km/h (3 mph) and above.
- There is a possibility of a collision with the vehicle ahead.

CAUTION:

It is the driver's responsibility to stay alert, drive safely and be in control of the vehicle at all times. As there is a performance limit, it may not provide a warning or brake in certain conditions.

BRAKE ASSIST (WITH PREVIEW FUNCTION) : Fail-safe (ICC RADAR)

INFOID:000000012894541

If a malfunction occurs in each system, ADAS control unit cancels each control, sounds a beep, and turns ON the warning or indicator lamp.

System	Buzzer	Warning lamp/Warning display	Description
Intelligent Cruise Control (ICC)	High-pitched tone	ICC system warning	Cancel
Conventional (fixed speed) cruise control mode	High-pitched tone	ICC system warning	Cancel
Forward Emergency Braking (FEB)	High-pitched tone	FEB warning lamp (Yellow)	Cancel
Predictive Forward Collision Warning (PFCW)	High-pitched tone	FEB warning lamp (Yellow)	Cancel
Blind Spot Warning (BSW)	Low-pitched tone	BSW system warning (Orange)	Cancel

WARNING/INDICATOR/CHIME LIST

WARNING/INDICATOR/CHIME LIST : Warning Lamp/Indicator Lamp

INFOID:000000012894542

Name	Design	Function
FEB warning lamp		<ul style="list-style-type: none"> • For layout, refer to MWI-6, "METER SYSTEM : Design".

OPERATION

< SYSTEM DESCRIPTION >

[WITH ICC]

OPERATION

Switch Name and Function

INFOID:000000012894543

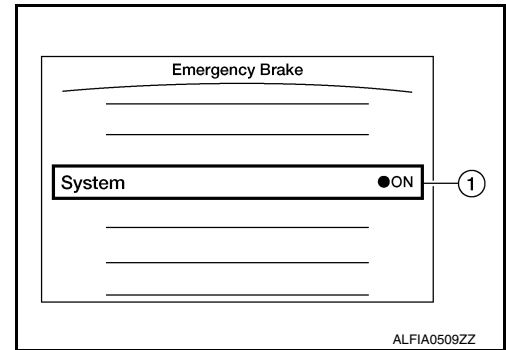

No.	Switch name	Description
①	FEB system setting screen (Integral switch settings screen)	The setting of FEB/PFCW system can be switched between ON and OFF

Menu Displayed by Pressing Each Switch

INFOID:000000012894544

SYSTEM DISPLAY

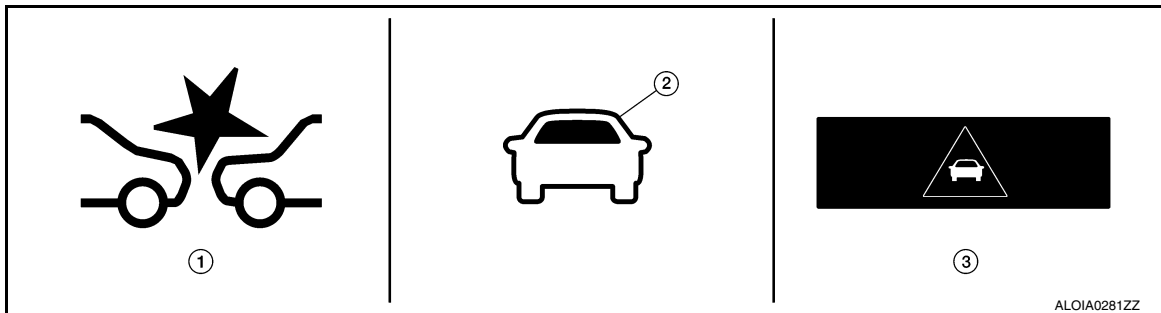

No.	Switch name	Description
1.	FEB warning lamp	<ul style="list-style-type: none"> FEB warning lamp indicates that an abnormal condition is present in FEB system When the FEB system turns OFF, the FEB warning lamp will illuminate.
2.	Vehicle ahead detection indicator	<ul style="list-style-type: none"> Indicates whether it detects a vehicle ahead Blinks when approaching vehicle ahead
3.	FEB warning	Displays immediately before the harder brake operates

DISPLAY AND WARNING

Warning Display

System status	Condition	Display on combination meter	FEB warning lamp	Buzzer
FEB/PFCW OFF	—	—	OFF	—



OPERATION

< SYSTEM DESCRIPTION >

[WITH ICC]

System status	Condition	Display on combination meter	FEB warning lamp	Buzzer
FEB/PFCW ON	System ON	 <small>ALFIA0531ZZ</small>	ON	—
FEB/PFCW system malfunction	The FEB/PFCW system is automatically canceled. NOTE: The system operates if the ignition switch is turned OFF⇒ON after the condition improves	Malfuction See Owner's Manual	ON	Beep

Warning Operation

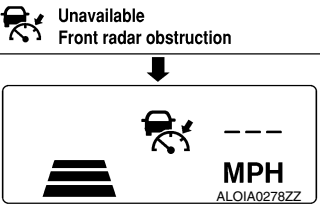
Condition	Action	Display on combination meter	FEB warning lamp	Chime
There is a possibility of a collision with the vehicle ahead	<ul style="list-style-type: none"> Accelerator pedal actuation Operates brake (Partial) 	 <small>ALFIA0532ZZ</small>	FLASHING	Beep
An obstacle ahead is avoided due to the system applying braking.	Operates brake (Emergency)	 <small>JSOIA0957ZZ</small>	ON	Continuous beeps
Dirt around the ICC sensor	The FEB system is automatically canceled. NOTE: The system operates if the ignition switch is turned OFF⇒ON after the condition improves	 <small>ALOIA0278ZZ</small>	ON	—

A
B
C
D
E

BRC

G
H
I
J
K
L
M
N
O
P

HANDLING PRECAUTION

Description

INFOID:000000012894545

PRECAUTIONS FOR FORWARD EMERGENCY BRAKING

- The forward emergency braking system is a supplemental aid to the driver. It is not a replacement for the driver's attention to traffic conditions or responsibility to drive safely. It cannot prevent accidents due to carelessness or dangerous driving techniques.
- The forward emergency braking system does not function in all driving, traffic, weather and road conditions.
- The automatic braking will cease under the following conditions:
 - When the steering wheel is turned as far as necessary to avoid a collision.
 - When the accelerator pedal is depressed.
 - When there is no longer a vehicle detected ahead.
- If the forward emergency braking system has stopped the vehicle, the vehicle will remain at a standstill for approximately 2 seconds before the brakes are released.
- The system will not detect the following objects:
 - Pedestrians, animals, or obstacles in the roadway
 - Oncoming vehicles in the same lane
 - Crossing vehicles
- The radar sensor has some performance limitations. For stationary vehicles, the forward emergency braking system can function at speeds up to approximately 80 km/h (50 MPH).
- The radar sensor may not detect a vehicle ahead in the following conditions:
 - Dirt, ice, snow or other material covering the radar sensor.
 - Interference by other radar sources.
 - Snow or road spray from traveling vehicles.
 - If the vehicle ahead is narrow (e.g. motorcycle)
 - When driving on a steep downhill slope or roads with sharp curves.
- In some road or traffic conditions, the forward emergency braking system may unexpectedly apply partial braking. When acceleration is necessary, continue to depress the accelerator pedal to override the system.
- Braking distances increase on slippery surfaces.
- Excessive noise will interfere with the warning chime sound, and the chime may not be heard.
- When towing a trailer.

DIAGNOSIS SYSTEM [ABS ACTUATOR AND ELECTRIC UNIT (CONTROL UNIT)]

< SYSTEM DESCRIPTION >

[WITH ICC]

DIAGNOSIS SYSTEM [ABS ACTUATOR AND ELECTRIC UNIT (CONTROL UNIT)]

CONSULT Function

INFOID:000000012894546

APPLICATION ITEMS

CONSULT can display each diagnostic item using the diagnostic test modes as follows:

Mode	Function description
ECU Identification	Part number of ABS actuator and electric unit (control unit) can be read.
Self Diagnostic Result	Self-diagnostic results and freeze frame data can be read and erased quickly.*
Data Monitor	Input/Output data in the ABS actuator and electric unit (control unit) can be read.
Active Test	Diagnostic Test Mode in which CONSULT drives some actuators apart from the ABS actuator and electric unit (control unit) and also shifts some parameters in a specified range.
Work support	Components can be quickly and accurately adjusted.
Re/programming, Configuration	<ul style="list-style-type: none">• Read and save the vehicle specification (TYPE ID).• Write the vehicle specification (TYPE ID) when replacing ABS actuator and electric unit (control unit).

*: The following diagnosis information is erased by erasing:

- DTC
- Freeze frame data (FFD)

ECU IDENTIFICATION

ABS actuator and electric unit (control unit) part number can be read.

SELF DIAGNOSTIC RESULT

Refer to [BRC-51, "DTC Index"](#).

When "CRNT" is displayed on self-diagnosis result

- The system is presently malfunctioning.

When "PAST" is displayed on self-diagnosis result

- System malfunction in the past was detected, but the system is presently normal.

Freeze frame data (FFD)

The following vehicle status is recorded when DTC is detected and is displayed on CONSULT.

Item name	Display item
IGN counter (0 – 39)	<p>The number of times that ignition switch is turned ON after the DTC is detected is displayed.</p> <ul style="list-style-type: none">• When "0" is displayed: It indicates that the system is presently malfunctioning.• When except "0" is displayed: It indicates that system malfunction in the past was detected, but the system is presently normal. <p>NOTE: Each time when ignition switch is turned OFF to ON, numerical number increases from 1 → 2 → 3...38 → 39. When the operation number of times exceeds 39, the number does not increase and "39" is displayed until self-diagnosis is erased.</p>

ACTIVE TEST

The active test is used to determine and identify details of a malfunction, based on self-diagnosis test results and data obtained in the Data Monitor. In response to instructions from CONSULT instead of those from ABS actuator and electric unit (control unit) on the vehicle, a drive signal is sent to the actuator to check its operation.

CAUTION:

- **Never perform Active Test while driving the vehicle.**
- **Always bleed air from brake system before active test.**
- **Never perform active test when system is malfunctioning.**

NOTE:

- When active test is performed while depressing the pedal, the pedal depressing stroke may change. This is not a malfunction.
- "TEST IS STOPPED" is displayed approximately 10 seconds after operation start.

DIAGNOSIS SYSTEM [ABS ACTUATOR AND ELECTRIC UNIT (CONTROL UNIT)]

< SYSTEM DESCRIPTION >

[WITH ICC]

- When performing active test again after “TEST IS STOPPED” is displayed, select “BACK”.
- ABS warning lamp, brake warning lamp and VDC warning lamp may turn ON during active test. This is not a malfunction.

ABS IN Valve and ABS OUT Valve

When “Up”, “Keep” or “Down” is selected on display screen, the following items are displayed when system is normal:

Test item	Display Item	Display		
		Up	Keep	Down
FR RH SOL	FR RH IN SOL	Off	On*	On*
	FR RH OUT SOL	Off	Off	On*
FR LH SOL	FR LH IN SOL	Off	On*	On*
	FR LH OUT SOL	Off	Off	On*
RR RH SOL	RR RH IN SOL	Off	On*	On*
	RR RH OUT SOL	Off	Off	On*
RR LH SOL	RR LH IN SOL	Off	On*	On*
	RR LH OUT SOL	Off	Off	On*

*: Immediately after being selected, status is “On”. Status changes to “Off” after approximately 2 seconds.

ABS IN Valve (ACT) and ABS OUT Valve (ACT)

When “Up”, “ACT UP” or “ACT KEEP” is selected on display screen, the following items are displayed when system is normal.

Test item	Display Item	Display		
		Up	ACT UP	ACT KEEP
FR RH SOL (ACT)	FR RH IN SOL	Off	Off	Off
	FR RH OUT SOL	Off	Off	Off
	CV1	Off	Off	Off
	CV2	Off	On*	On*
FR LH SOL (ACT)	FR LH IN SOL	Off	Off	Off
	FR LH OUT SOL	Off	Off	Off
	CV1	Off	On*	On*
	CV2	Off	Off	Off
RR RH SOL (ACT)	RR RH IN SOL	Off	Off	Off
	RR RH OUT SOL	Off	Off	Off
	CV1	Off	On*	On*
	CV2	Off	Off	Off
RR LH SOL (ACT)	RR LH IN SOL	Off	Off	Off
	RR LH OUT SOL	Off	Off	Off
	CV1	Off	Off	Off
	CV2	Off	On*	On*

*: Immediately after being selected, status is “On”. Status changes to “Off” after approx. 10 seconds.

ABS MOTOR

When “On” or “Off” is selected on display screen, the following items are displayed when system is normal.

Test item	Display Item	Display	
		On	Off
ABS MOTOR	MOTOR RELAY	On	Off
	ACTUATOR RLY ^(Note)	On	On

DIAGNOSIS SYSTEM [ABS ACTUATOR AND ELECTRIC UNIT (CONTROL UNIT)]

< SYSTEM DESCRIPTION >

[WITH ICC]

NOTE:

Display occasionally changes On/Off for a moment after ignition switch is turned ON. This is operation for checking purposes and is not a malfunction.

DATA MONITOR

NOTE:

The following table includes information (items) inapplicable to this vehicle. For information (items) applicable to this vehicle, refer to CONSULT display items.

×: Applicable

Item (Unit)	Monitor item selection		Note
	INPUT SIGNALS	MAIN SIGNALS	
FR LH SENSOR [km/h (MPH)]	×	×	Wheel speed calculated by front LH wheel sensor is displayed.
FR RH SENSOR [km/h (MPH)]	×	×	Wheel speed calculated by front RH wheel sensor is displayed.
RR LH SENSOR [km/h (MPH)]	×	×	Wheel speed calculated by rear LH wheel sensor is displayed.
RR RH SENSOR [km/h (MPH)]	×	×	Wheel speed calculated by rear RH wheel sensor is displayed.
DECEL G-SEN (m/s ²)	×	×	Decel G detected by decel G sensor is displayed.
FR RH IN SOL (On/Off)		×	Operation status of front RH wheel ABS IN valve is displayed.
FR RH OUT SOL (On/Off)		×	Operation status of front RH wheel ABS OUT valve is displayed.
FR LH IN SOL (On/Off)		×	Operation status of front LH wheel ABS IN valve is displayed.
FR LH OUT SOL (On/Off)		×	Operation status of front LH wheel ABS OUT valve is displayed.
RR RH IN SOL (On/Off)		×	Operation status of rear RH wheel ABS IN valve is displayed.
RR RH OUT SOL (On/Off)		×	Operation status of rear RH wheel ABS OUT valve is displayed.
RR LH IN SOL (On/Off)		×	Operation status of rear LH wheel ABS IN valve is displayed.
RR LH OUT SOL (On/Off)		×	Operation status of rear LH wheel ABS OUT valve is displayed.
EBD WARN LAMP (On/Off)			Brake warning lamp ON/OFF status is displayed. (Note 1)
STOP LAMP SW (On/Off)	×	×	Stop lamp switch signal input status is displayed.
MOTOR RELAY (On/Off)		×	ABS motor and motor relay status is displayed.
ACTUATOR RLY (On/Off)		×	ABS actuator relay status is displayed.
ABS WARN LAMP (On/Off)		×	ABS warning lamp ON/OFF status is displayed. (Note 1)
OFF LAMP (On/Off)		×	VDC OFF indicator lamp ON/OFF status is displayed. (Note 1)
OFF SW (On/Off)	×	×	VDC OFF switch status is displayed.
SLIP/VDC LAMP (On/Off)		×	VDC warning lamp ON/OFF status is displayed. (Note 1)
BATTERY VOLT (V)	×	×	Voltage supplied to ABS actuator and electric unit (control unit) is displayed.

DIAGNOSIS SYSTEM [ABS ACTUATOR AND ELECTRIC UNIT (CONTROL UNIT)]

< SYSTEM DESCRIPTION >

[WITH ICC]

Item (Unit)	Monitor item selection		Note
	INPUT SIGNALS	MAIN SIGNALS	
GEAR	×	×	Current gear position judged from current gear position signal is displayed.
ENGINE SPEED (tr/min)	×	×	Engine speed status is displayed.
SLCT LVR POSI	×	×	Current gear position judged from current gear position signal is displayed.
YAW RATE SEN (d/s)	×	×	Yaw rate detected by yaw rate sensor is displayed.
R POSI SIG (On/Off)			R range signal input status judged from R range signal is displayed.
4WD MODE MON ^(Note 2) (AUTO/LOCK/2WD)	×	×	AWD control status is displayed.
N POSI SIG (On/Off)			N range signal input status judged from N range signal is displayed.
P POSI SIG (On/Off)			P range signal input status judged from P range signal is displayed.
CV1 (On/Off)			Cut valve 1 (On/Off) status is displayed.
CV2 (On/Off)			Cut valve 2 (On/Off) status is displayed.
ACCEL POS SIG (%)	×		Displays the Accelerator pedal position
SIDE G-SENSOR (m/s ²)	×		Side G detected by side G sensor is displayed.
STR ANGLE SIG	×		Steering angle detected by steering angle sensor is displayed.
PRESS SENSOR (bar)	×		Brake fluid pressure detected by pressure sensor is displayed.
EBD SIGNAL (On/Off)			EBD operation status is displayed.
ABS SIGNAL (On/Off)			ABS operation status is displayed.
TCS SIGNAL (On/Off)			TCS operation status is displayed.
VDC SIGNAL (On/Off)			VDC operation status is displayed.
EBD FAIL SIG (On/Off)			EBD fail-safe signal status is displayed.
ABS FAIL SIG (On/Off)			ABS fail-safe signal status is displayed.
TCS FAIL SIG (On/Off)			TCS fail-safe signal status is displayed.
VDC FAIL SIG (On/Off)			VDC fail-safe signal status is displayed.
CRANKING SIG (On/Off)			Cranking status is displayed.
FLUID LEV SW (On/Off)	×		Brake fluid level signal input status via CAN communication is displayed.
USS SIG ^(Note 3) (On/Off)			hill start assist operation status is displayed.

DIAGNOSIS SYSTEM [ABS ACTUATOR AND ELECTRIC UNIT (CONTROL UNIT)]

[WITH ICC]

< SYSTEM DESCRIPTION >

Note 1: Refer to [BRC-209. "WARNING/INDICATOR/CHIME LIST : Warning Lamp/Indicator Lamp"](#) for ON/OFF conditions of each warning lamp and indicator lamp.

Note 2: AWD models

Note 3: USS (Hill Start Assist)

WORK SUPPORT

Conditions	Description
ST ANGLE SENSOR ADJUSTMENT	Perform neutral position adjustment of steering angle sensor.
DECEL G SEN CALIBRATION	Perform decel G sensor calibration.

CONFIGURATION

Configuration includes the following functions:

Function	Description
Read/Write Configuration	Before replacing ECU Allows the reading of vehicle specification (Type ID) written in the ABS actuator and electric unit (control unit) to store the specification in CONSULT.
	After replacing ECU Allows the writing of vehicle information (Type ID) stored in CONSULT into the ABS actuator and electric unit (control unit).
Manual Configuration	Allows the writing of vehicle information (Type ID) into the ABS actuator and electric unit (control unit) by hand.

CAUTION:

Use "Manual Configuration" "TYPE ID"

A
B
C
D
E
BRC
G
H
I
J
K
L
M
N
O
P

DIAGNOSIS SYSTEM (ICC SENSOR)

[WITH ICC]

< SYSTEM DESCRIPTION >

DIAGNOSIS SYSTEM (ICC SENSOR)

CONSULT Function (LASER/RADAR)

INFOID:000000012894547

CAUTION:

After disconnecting the CONSULT vehicle interface (VI) from the data link connector, the ignition must be cycled OFF → ON (for at least 5 seconds) → OFF. If this step is not performed, the BCM may not go to “sleep mode”, potentially causing a discharged battery and a no-start condition.

APPLICATION ITEMS

CONSULT performs the following functions via CAN communication with ADAS control unit and the communication with ICC sensor.

Diagnosis mode	Description
Self Diagnostic Result	Displays malfunctioning system memorized in ICC sensor
Data Monitor	Displays real-time input/output data of ICC sensor
Work support	It can monitor the adjustment direction indication in order to perform the radar adjustment operation smoothly
ECU Identification	Displays ICC sensor part number
CAN Diag Support Monitor	The results of transmit/receive diagnosis of ITS communication can be read.

SELF DIAGNOSTIC RESULT

Refer to [CCS-46. "DTC Index"](#).

DATA MONITOR

Monitored item [Unit]	Description
VHCL SPEED SE [km/h] or [mph]	Vehicle speed judged from a vehicle speed signal read by the ICC sensor via ITS communication is displayed [ADAS control unit receives a vehicle speed signal from ABS actuator and electric unit (control unit) via CAN communication and transmits the calculated vehicle speed to ICC sensor via ITS communication].
YAW RATE [deg/s]	Indicates yaw rate read from ADAS control unit through ITS communication [ADAS control unit receives yaw rate signal from ABS actuator and electric unit (control unit) via CAN communication and transmits yaw rate calculated by the ADAS control unit] Yaw rate judged from a yaw rate signal read by ICC sensor via ITS communication is displayed [ADAS control unit receives a yaw rate signal from ABS actuator and electric unit (control unit) via CAN communication and transmits the calculated yaw rate to ICC sensor via ITS communication].
PWR SUP MONI [V]	Indicates IGN voltage input by ICC sensor
DISTANCE [m]	Indicates the distance from the vehicle ahead
RELATIVE SPD [m/s]	Indicates the relative speed of the vehicle ahead
RADAR OFFSET [m]	NOTE: The item is indicated but not used.
RADAR HEIGHT [m]	NOTE: The item is indicated but not used.
STEERING ANGLE [deg]	The steering angle is displayed.
STRG ANGLE SPEED [deg/s]	The steering angle speed is displayed.
L/R ADJUST [deg]	Indicates a horizontal correction value of the radar
U/D ADJUST [deg]	Indicates a vertical correction value of the radar

DIAGNOSIS SYSTEM (ICC SENSOR)

[WITH ICC]

< SYSTEM DESCRIPTION >

Monitored item [Unit]	Description	
FCW SYSTEM ON	NOTE: The item is indicated, but not used.	A
FCW SELECT	NOTE: The item is indicated, but not used.	B
PFCW SELECT	NOTE: The item is indicated, but not used.	C
FEB SW	NOTE: The item is indicated, but not used.	
FEB SELECT	Indicates [ON/OFF] state of the PFCW system.	D
MAIN SW	Indicates [ON/OFF] status as judged from ICC steering switch.	
ICC/ASCD MODE	NOTE: The item is indicated, but not used.	E
SET/COAST SW	Indicates [ON/OFF] status as judged from ICC steering switch.	
CANCEL SW	Indicates [ON/OFF] status as judged from ICC steering switch.	BRC
RESUME/ACC SW	Indicates [ON/OFF] status as judged from ICC steering switch.	
DISTANCE SW	Indicates [ON/OFF] status as judged from ICC steering switch.	
BRAKE SW	Indicates [ON/OFF] status as judged from brake pedal position switch signal [ECM transmits brake pedal position switch signal through CAN communication].	G
STOP LAMP SW	Indicates [ON/OFF] status as judged from stop lamp switch signal [ABS actuator and electric unit (control unit) transmits stop lamp switch signal through CAN communication].	H
IDLE SW	Indicates [ON/OFF] status of idle switch read from ICC sensor through CAN communication (ECM transmits ON/OFF status through CAN communication).	
CRUISE LAMP	Indicates [ON/OFF] status of MAIN switch indicator output.	I
OWN VHCL	NOTE: The item is indicated, but not used.	
VHCL AHEAD	Indicates [ON/OFF] status of vehicle ahead detection indicator output.	J
SET DISTANCE	Indicates set distance memorized in ADAS control unit.	
SET VHCL SPD [km/h] or [mph]	NOTE: The item is indicated, but not used.	K
THRTL SENSOR [%]	Indicates throttle position read from ISS sensor through CAN communication (ECM transmits accelerator pedal position signal through CAN communication).	L
VEHICLE AHEAD DETECT	Indicates [ON/OFF] status of vehicle ahead detection indicator output.	
STATIC OBSTACLE DETECT	Indicates [ON/OFF] status of static obstacle detection.	
BUZZER O/P	[ON/OFF] Indicates [On/Off] status of warning chime output.	M
FUNC ITEM (FCW)	NOTE: The item is indicated, but not used.	
FUNC ITEM (PFCW)	Indicates systems status	N
FUNC ITEM (FEB)	Indicates systems status	
FUNC ITEM (ICC)	Indicates systems status	O
PRESS_ORDER [bar]	Indicates status as judged from brake fluid pressure signal [ABS actuator and electric unit (control unit) transmits brake fluid pressure signal through CAN communication].	
D RANGE SW	Indicates [ON/OFF] status as judged from D position switch signal (TCM transmits shift position signal through CAN communication).	P
NP RANGE SW	Indicates [ON/OFF] status as judged from N/P position switch signal (TCM transmits shift position signal through CAN communication).	
PKB SW	Parking brake switch status [ON/OFF] judges from the parking brake switch signal that ADAS control unit readout via CAN communication is displayed (combination meter transmits the parking brake switch signal via CAN communication)	

DIAGNOSIS SYSTEM (ICC SENSOR)

[WITH ICC]

< SYSTEM DESCRIPTION >

Monitored item [Unit]	Description
VHCL SPD AT	NOTE: The item is indicated, but not used.
Shift position	Indicates shift position read from ADAS control unit though CAN communication (TCM transmits shift position signal through CAN communication).
Turn signal	NOTE: The item is indicated, but not used.
SYSTEM CANCEL MESSAGE	Indicates [ON/OFF] status of system cancel display output.
DISP VHCL SPD [km/h] or [mph]	NOTE: The item is indicated, but not used.
VHCL SPD UNIT	Indicates vehicle speed unit read from ICC sensor through CAN communication (combination meter transmits vehicle speed unit through CAN communications).
ADAS AVAILABLE COND	NOTE: The item is indicated, but not used.
ICC SET STATUS	NOTE: The item is indicated, but not used.
ICC MALF	NOTE: The item is indicated, but not used.
ADAS MALF	Indicates [ON/OFF] status of ADAS malfunction.
STOP LAMP RELAY ON	Indicates [ON/OFF] status of stop lamp relay fixed on.
STOP LAMP RELAY OFF	Indicates [ON/OFF] status of stop lamp relay fixed off.
ICC CANCEL	
ACCEL COM VALUE 1 [m/s ²]	Indicates accel command calculated from set speed and information of ahead vehicle.
ICC STATUS	Indicates ICC status.
ACCEL COM VALUE 2	NOTE: The item is indicated, but not used.

WORK SUPPORT

Work support items	Description
MILLIWAVE RADAR ADJUST	Outputs millimeter waves, calculates the displacement in radar direction, and indicates an adjustment direction
CAUSE OF AUTO-CANCEL	Displays causes of automatic cancellation occurred during Intelligent Cruise Control system.

ICC sensor Adjust

Refer to [CCS-57, "Description"](#).

ECU IDENTIFICATION

ICC sensor part number is displayed.

CAUSE OF AUTO CANCEL

Work support items	Description
OPERATING ABS	ABS function was operated.
OPERATING TCS	TCS function was operated.
OPERATING VDC	VDC function was operated.
ECM CIRCUIT	ECM did not permit ICC operation.
OP SW VOLT CIRC	The ICC steering switch input voltage is not within standard range.
OP SW DOUBLE TOUCH	The ICC steering switches were pressed at the same time.
VHCL SPD DOWN	Vehicle speed is lower than the speed as follows: <ul style="list-style-type: none"> • Vehicle to vehicle control mode is 24 km/h (15 mph). • Conventional (fixed speed) cruise control mode is 32 km/h (20 mph).

DIAGNOSIS SYSTEM (ICC SENSOR)

[WITH ICC]

< SYSTEM DESCRIPTION >

Work support items	Description	
WHL SPD ELEC NOISE	Wheel speed sensor signal caught electromagnetic noise.	A
VDC/TCS OFF SW	VDC OFF switch was pressed.	
VHCL SPD UNMATCH	Wheel speed became different from CVT vehicle speed.	B
TIRE SLIP	Wheel slipped.	
IGN LOW VOLT	Decrease in ICC sensor ignition voltage.	
PARKING BRAKE ON	The parking brake is operating.	C
WHEEL SPD UNMATCH	The wheel speed of all four wheels are out of the specified values.	
INCHING LOST	a vehicle ahead is not detected during the following driving when the vehicle speed is approximately 24 km/h (15mph) or less.	D
CAN COMM ERROR	ICC sensor received an abnormal signal with CAN communication.	
ABS/TCS/VDC CIRC	An abnormal condition occurs in VDC/TCS/ABS system.	E
ECD CIRCUIT	An abnormal condition occurs in ECD system.	
ASCD VHCL SPD DTAC	Vehicle speed is detached from the set vehicle speed.	
ASCD DOUBLE COMD	Cancel switch and operation switch are detected simultaneously.	BRC
FEB OPERATED	FEB activated.	
VHL AHAD LOST (CLSE RANGE)	A vehicle ahead lost close range.	G
NO RECORD	—	
		H
		I
		J
		K
		L
		M
		N
		O
		P

ABS ACTUATOR AND ELECTRIC UNIT (CONTROL UNIT)

< ECU DIAGNOSIS INFORMATION >

[WITH ICC]

ECU DIAGNOSIS INFORMATION

ABS ACTUATOR AND ELECTRIC UNIT (CONTROL UNIT)

Reference Value

INFOID:0000000012894548

VALUES ON THE DIAGNOSIS TOOL

CAUTION:

The display shows the control unit calculation data, so a normal value might be displayed even in the event the output circuit (harness) is open or short-circuited.

Monitor item	Display content	Data monitor	
		Condition	Reference value in normal operation
FR LH SENSOR	Wheel speed	0 [km/h, mph]	Vehicle stopped
		Nearly matches the speed meter display (± 10% or less)	Vehicle running (Note 1)
FR RH SENSOR	Wheel speed	0 [km/h, mph]	Vehicle stopped
		Nearly matches the speed meter display (± 10% or less)	Vehicle running (Note 1)
RR LH SENSOR	Wheel speed	0 [km/h, mph]	Vehicle stopped
		Nearly matches the speed meter display (± 10% or less)	Vehicle running (Note 1)
RR RH SENSOR	Wheel speed	0 [km/h, mph]	Vehicle stopped
		Nearly matches the speed meter display (± 10% or less)	Vehicle running (Note 1)
DECEL G-SEN	Longitudinal acceleration detected by decel G sensor	Vehicle stopped	Approx. 0 G
		Vehicle running	-1.7 to 1.7 G
FR RH IN SOL	Operation status of all solenoid valves	Actuator (solenoid valve) is active ("ACTIVE TEST" with CONSULT) or actuator relay is inactive (in fail-safe mode)	On
		When the actuator (solenoid valve) is not active and actuator relay is active (ignition switch ON)	Off
FR RH OUT SOL	Operation status of all solenoid valves	Actuator (solenoid valve) is active ("ACTIVE TEST" with CONSULT) or actuator relay is inactive (in fail-safe mode)	On
		When the actuator (solenoid valve) is not active and actuator relay is active (ignition switch ON)	Off
FR LH IN SOL	Operation status of all solenoid valves	Actuator (solenoid valve) is active ("ACTIVE TEST" with CONSULT) or actuator relay is inactive (in fail-safe mode)	On
		When the actuator (solenoid valve) is not active and actuator relay is active (ignition switch ON)	Off
FR LH OUT SOL	Operation status of all solenoid valves	Actuator (solenoid valve) is active ("ACTIVE TEST" with CONSULT) or actuator relay is inactive (in fail-safe mode)	On
		When the actuator (solenoid valve) is not active and actuator relay is active (ignition switch ON)	Off

ABS ACTUATOR AND ELECTRIC UNIT (CONTROL UNIT)

< ECU DIAGNOSIS INFORMATION >

[WITH ICC]

Monitor item	Display content	Data monitor		
		Condition	Reference value in normal operation	
RR RH IN SOL	Operation status of all solenoid valves	Actuator (solenoid valve) is active ("ACTIVE TEST" with CONSULT) or actuator relay is inactive (in fail-safe mode)	On	A
		When the actuator (solenoid valve) is not active and actuator relay is active (ignition switch ON)	Off	B
RR RH OUT SOL	Operation status of all solenoid valves	Actuator (solenoid valve) is active ("ACTIVE TEST" with CONSULT) or actuator relay is inactive (in fail-safe mode)	On	C
		When the actuator (solenoid valve) is not active and actuator relay is active (ignition switch ON)	Off	D
RR LH IN SOL	Operation status of all solenoid valves	Actuator (solenoid valve) is active ("ACTIVE TEST" with CONSULT) or actuator relay is inactive (in fail-safe mode)	On	E
		When the actuator (solenoid valve) is not active and actuator relay is active (ignition switch ON)	Off	BRC
RR LH OUT SOL	Operation status of all solenoid valves	Actuator (solenoid valve) is active ("ACTIVE TEST" with CONSULT) or actuator relay is inactive (in fail-safe mode)	On	G
		When the actuator (solenoid valve) is not active and actuator relay is active (ignition switch ON)	Off	H
EBD WARN LAMP	EBD warning lamp (Note 2)	When EBD warning lamp is ON	On	I
		When EBD warning lamp is OFF	Off	
STOP LAMP SW	Brake pedal operation	When brake pedal is depressed	On	J
		When brake pedal is not depressed	Off	
MOTOR RELAY	Motor and motor relay operation	When the motor relay and motor are operating	On	K
		When the motor relay and motor are not operating	Off	
ACTUATOR RLY	Actuator relay operation	When the actuator relay is operating	On	L
		When the actuator relay is not operating	Off	
ABS WARN LAMP	ABS warning lamp (Note 2)	When ABS warning lamp is ON	On	M
		When ABS warning lamp is OFF	Off	
OFF LAMP	VDC OFF indicator lamp (Note 2)	When VDC OFF indicator lamp is ON	On	N
		When VDC OFF indicator lamp is OFF	Off	
OFF SW	VDC OFF switch	When VDC OFF switch is ON	On	O
		When VDC OFF switch is OFF	Off	
SLIP/VDC LAMP	SLIP indicator lamp (Note 2)	When SLIP indicator lamp is ON	On	P
		When SLIP indicator lamp is OFF	Off	
BATTERY VOLT	Battery voltage supplied to the ABS actuator and electric unit (control unit)	Ignition switch ON	10 – 16 V	
GEAR	Manual mode gear position determined by TCM	1st gear	1	
		2nd gear	2	
		3rd gear	3	
		4th gear	4	
		5th gear	5	

ABS ACTUATOR AND ELECTRIC UNIT (CONTROL UNIT)

< ECU DIAGNOSIS INFORMATION >

[WITH ICC]

Monitor item	Display content	Data monitor	
		Condition	Reference value in normal operation
ENGINE SPEED	With engine running	With engine stopped	0 RPM
		Engine running	Almost in accordance with tachometer display
YAW RATE SEN	Yaw rate detected by yaw rate/side G sensor	Vehicle stopped	Approx. 0 d/s
		Vehicle turning	-75 to 75 d/s
R POSI SIG	Transmission range switch signal ON/OFF condition	CVT shift position = R position	On
		CVT shift position = other than R position	Off
4WD MODE MON	Always (Note 3)	AUTO, LOCK, FWD	AUTO, LOCK, FWD (depending on AWD control status)
N POSI SIG	Transmission range switch signal ON/OFF condition	CVT shift position = N position	On
		CVT shift position = other than N position	Off
CV1	Cut valve 1 signal	When cut valve 1 is open or closed	On
			Off
CV2	Cut valve 2 signal	When cut valve 2 is open or closed	On
			Off
ACCEL POS SIG	Throttle actuator opening/closing is displayed (linked with accelerator pedal)	Accelerator pedal not depressed (ignition switch is ON)	0 %
		Depress accelerator pedal (ignition switch is ON)	0 - 100 %
SIDE G-SENSOR	Transverse G detected by side G sensor	Vehicle stopped	Approx. 0 m/s ²
		Vehicle turning right	Negative value (m/s ²)
		Vehicle turning left	Positive value (m/s ²)
STR ANGLE SIG	Steering angle detected by steering angle sensor	Straight-ahead	Approx. 0°
		Steering wheel turned	-720 to 720°
PRESS SENSOR	Brake fluid pressure detected by pressure sensor	With ignition switch turned ON and brake pedal released	Approx. 0 bar
		With ignition switch turned ON and brake pedal depressed	-40 to 300 bar (Pressure increases according to pedaleffort.)
EBD SIGNAL	EBD operation	EBD is active	On
		EBD is inactive	Off
ABS SIGNAL	ABS operation	ABS is active	On
		ABS is inactive	Off
TCS SIGNAL	TCS operation	TCS is active	On
		TCS is inactive	Off
VDC SIGNAL	VDC operation	VDC is active	On
		VDC is inactive	Off
EBD FAIL SIG	EBD fail-safe signal	In EBD fail-safe	On
		EBD is normal	Off
ABS FAIL SIG	ABS fail-safe signal	In ABS fail-safe	On
		ABS is normal	Off

ABS ACTUATOR AND ELECTRIC UNIT (CONTROL UNIT)

< ECU DIAGNOSIS INFORMATION >

[WITH ICC]

Monitor item	Display content	Data monitor	
		Condition	Reference value in normal operation
TCS FAIL SIG	TCS fail-safe signal	In TCS fail-safe	On
		TCS is normal	Off
VDC FAIL SIG	VDC fail-safe signal	In VDC fail-safe	On
		VDC is normal	Off
CRANKING SIG	Crank operation	Crank is active	On
		Crank is inactive	Off
FLUID LEV SW	Brake fluid level switch	When brake fluid level switch ON	On
		When brake fluid level switch OFF	Off
USS SIG (On/Off)	Hill start assist status (Note 4)	When hill start assist is active	On
		When hill start assist is not active	Off

Note 1: Confirm tire pressure is normal.

Note 2: On and off timing for warning lamps and indicator lamps.

Note 3: AWD models

Note 4: USS (Hill Start Assist)

- Refer to [BRC-28, "VDC FUNCTION : System Description"](#).
- Refer to [BRC-30, "TCS FUNCTION : System Description"](#).
- Refer to [BRC-32, "ABS FUNCTION : System Description"](#).
- Refer to [BRC-34, "EBD FUNCTION : System Description"](#).

Fail-Safe

INFOID:000000012894549

VDC FUNCTION, TCS FUNCTION, BRAKE ASSIST FUNCTION and HILL START ASSIST FUNCTION

VDC warning lamp in combination meter turn ON when a malfunction occurs in system [ABS actuator and electric unit (control unit)]. The control is suspended for VDC function, TCS function, brake assist function and hill start assist function. The vehicle status becomes the same as models without VDC function, TCS function, brake assist function and hill start assist function. However, ABS function and EBD function are operated normally.

ABS FUNCTION

ABS warning lamp and VDC warning lamp in combination meter turn ON when a malfunction occurs in system [ABS actuator and electric unit (control unit)]. The control is suspended for VDC function, TCS function, ABS function, Brake assist function, hill start assist function and brake force distribution function. The vehicle status becomes the same as models without VDC function, TCS function, ABS function and hill start assist function. However, EBD function is operated normally.

NOTE:

ABS self-diagnosis sound may be heard the same as in the normal condition, because self-diagnosis is performed when ignition switch turns ON and when vehicle initially starts.

EBD FUNCTION

ABS warning lamp, brake warning lamp and VDC warning lamp in combination meter turn ON when a malfunction occurs in system [ABS actuator and electric unit (control unit)]. The control is suspended for VDC function, TCS function, ABS function, EBD function, brake assist function and hill start assist function. The vehicle status becomes the same as models without VDC function, TCS function, ABS function, EBD function, brake assist function and hill start assist function.

ABS ACTUATOR AND ELECTRIC UNIT (CONTROL UNIT)

< ECU DIAGNOSIS INFORMATION >

[WITH ICC]

DTC	Fail-safe condition
C1101	The following functions are suspended: <ul style="list-style-type: none"> • VDC function • TCS function • ABS function • EBD function (only when both rear wheels are malfunctioning) • Brake assist function • Hill start assist function
C1102	
C1103	
C1104	
C1105	
C1106	
C1107	
C1108	
C1109	The following functions are suspended: <ul style="list-style-type: none"> • VDC function • TCS function • ABS function • EBD function • Brake assist function • Hill start assist function
C1111	
C1113	
C1115	The following functions are suspended: <ul style="list-style-type: none"> • VDC function • TCS function • ABS function • Brake assist function • Hill start assist function
C1116	
C1120	The following functions are suspended: <ul style="list-style-type: none"> • VDC function • TCS function • ABS function • EBD function • Brake assist function • Hill start assist function
C1121	
C1122	
C1123	
C1124	
C1125	
C1126	
C1127	
C1130	The following functions are suspended: <ul style="list-style-type: none"> • VDC function • TCS function • Hill start assist function
C1140	The following functions are suspended: <ul style="list-style-type: none"> • VDC function • TCS function • ABS function • EBD function • Brake assist function • Hill start assist function
C1142	The following functions are suspended: <ul style="list-style-type: none"> • VDC function • TCS function • Brake assist function • Hill start assist function
C1143	The following functions are suspended: <ul style="list-style-type: none"> • VDC function • TCS function • Hill start assist function
C1144	

ABS ACTUATOR AND ELECTRIC UNIT (CONTROL UNIT)

< ECU DIAGNOSIS INFORMATION >

[WITH ICC]

DTC	Fail-safe condition	
C1145	The following functions are suspended: • VDC function • TCS function • ABS function • Brake assist function • Hill start assist function	A
C1146		B
C1155	The following functions are suspended: • VDC function • TCS function • Brake assist function • Hill start assist function	C
C1160	The following functions are suspended: • VDC function • TCS function • ABS function • Brake assist function • Hill start assist function	D
C1164	The following functions are suspended: • VDC function • TCS function • ABS function • EBD function • Brake assist function • Hill start assist function	E
C1165		BRC
C1170	The following functions are suspended: • VDC function • TCS function • ABS function • Brake assist function • Hill start assist function	G
C1197	Electrical vacuum assistance of brake booster is suspended.	H
C1198		I
C1199		J
C119A		K
U1000	The following functions are suspended: • VDC function • TCS function • Hill start assist function	L

DTC Inspection Priority Chart

INFOID:0000000012894550

When multiple DTCs are displayed simultaneously, check one by one depending on the following priority list:

Priority	Detected item (DTC)	
1	• U1000 CAN COMM CIRCUIT	M
2	• C1170 VARIANT CODING	N
3	• C1130 ENGINE SIGNAL 1 • C1144 ST ANG SEN SIGNAL	O
4	• C1109 BATTERY VOLTAGE [ABNORMAL] • C1110 CONTROLLER FAILURE • C1140 ACTUATOR RLY	P

ABS ACTUATOR AND ELECTRIC UNIT (CONTROL UNIT)

< ECU DIAGNOSIS INFORMATION >

[WITH ICC]

Priority	Detected item (DTC)
5	<ul style="list-style-type: none"> • C1101 RR RH SENSOR-1 • C1102 RR LH SENSOR-1 • C1103 FR RH SENSOR-1 • C1104 FR LH SENSOR-1 • C1105 RR RH SENSOR-2 • C1106 RR LH SENSOR-2 • C1107 FR RH SENSOR-2 • C1108 FR LH SENSOR-2 • C1113 G SENSOR • C1115 ABS SENSOR [ABNORMAL] • C1116 STOP LAMP SW • C1120 FR LH IN ABS SOL • C1121 FR LH OUT ABS SOL • C1122 FR RH IN ABS SOL • C1123 FR RH OUT ABS SOL • C1124 RR LH IN ABS SOL • C1125 RR LH OUT ABS SOL • C1126 RR RH IN ABS SOL • C1127 RR RH OUT ABS SOL • C1142 PRESS SEN CIRCUIT • C1143 ST ANG SEN CIRCUIT • C1145 YAW RATE SENSOR • C1146 SIDE G SEN CIRCUIT • C1160 DECEL G SEN SET • C1164 CV 1 • C1165 CV 2 • C1197 VACUUM SENSOR • C1198 VACUUM SEN CIR • C1199 BRAKE BOOSTER • C119A VACUUM SEN VOLT
6	<ul style="list-style-type: none"> • C1155 BR FLUID LEVEL LOW

DTC Index

INFOID:000000012894551

DTC	Items (CONSULT screen terms)	Reference
C1101	RR RH SENSOR-1	BRC-263, "DTC Description"
C1102	RR LH SENSOR-1	
C1103	FR RH SENSOR-1	
C1104	FR LH SENSOR-1	
C1105	RR RH SENSOR-2	BRC-268, "DTC Description"
C1106	RR LH SENSOR-2	
C1107	FR RH SENSOR-2	
C1108	FR LH SENSOR-2	
C1109	BATTERY VOLTAGE [ABNORMAL]	BRC-275, "DTC Description"
C1111	PUMP MOTOR	BRC-279, "DTC Description"
C1113	G SENSOR	BRC-282, "DTC Description"
C1115	ABS SENSOR [ABNORMAL SIGNAL]	BRC-284, "DTC Description"
C1116	STOP LAMP SW	BRC-291, "DTC Description"
C1120	FR LH IN ABS SOL	BRC-297, "DTC Description"
C1121	FR LH OUT ABS SOL	BRC-299, "DTC Description"
C1122	FR RH IN ABS SOL	BRC-297, "DTC Description"
C1123	FR RH OUT ABS SOL	BRC-299, "DTC Description"
C1124	RR LH IN ABS SOL	BRC-297, "DTC Description"
C1125	RR LH OUT ABS SOL	BRC-299, "DTC Description"

ABS ACTUATOR AND ELECTRIC UNIT (CONTROL UNIT)

< ECU DIAGNOSIS INFORMATION >

[WITH ICC]

DTC	Items (CONSULT screen terms)	Reference	
C1126	RR RH IN ABS SOL	BRC-297, "DTC Description"	A
C1127	RR RH OUT ABS SOL	BRC-299, "DTC Description"	
C1130	ENGINE SIGNAL 1	BRC-301, "DTC Description"	B
C1140	ACTUATOR RLY	BRC-303, "DTC Description"	
C1142	PRESS SEN CIRCUIT	BRC-305, "DTC Description"	
C1143	ST ANG SEN CIRCUIT	BRC-308, "DTC Description"	C
C1144	ST ANG SEN SIGNAL	BRC-312, "DTC Description"	
C1145	YAW RATE SENSOR	BRC-282, "DTC Description"	D
C1146	SIDE G-SEN CIRCUIT		
C1155	BR FLUID LEVEL LOW	BRC-316, "DTC Description"	
C1160	DECEL G SEN SET	BRC-320, "DTC Description"	E
C1164	CV 1	BRC-322, "DTC Description"	
C1165	CV 2		BRC
C1170	VARIANT CODING	BRC-326, "DTC Description"	
C1197	VACUUM SENSOR	BRC-328, "DTC Description"	
C1198	VACUUM SEN CIR	BRC-331, "DTC Description"	G
C1199	BRAKE BOOSTER	BRC-333, "DTC Description"	
C119A	VACUUM SEN VOLT	BRC-336, "DTC Description"	
U1000	CAN COMM CIRCUIT	BRC-339, "DTC Description"	H
			I
			J
			K
			L
			M
			N
			O
			P

ADAS CONTROL UNIT

< ECU DIAGNOSIS INFORMATION >

[WITH ICC]

ADAS CONTROL UNIT

Reference Value

INFOID:000000013504704

VALUES ON THE DIAGNOSIS TOOL

NOTE:

The following table includes information (items) inapplicable to this vehicle. For information (items) applicable to this vehicle, refer to CONSULT display items.

Monitor item	Condition		Value/Status
MAIN SW	Ignition switch ON	When MAIN (ON/OFF) switch is pressed.	On
		When MAIN (ON/OFF) switch is not pressed.	Off
SET/COAST SW	Ignition switch ON	When SET/COAST switch is pressed.	On
		When SET/COAST switch is not pressed.	Off
CANCEL SW	Ignition switch ON	When CANCEL switch is pressed.	On
		When CANCEL switch is not pressed.	Off
RESUME/ACC SW	Ignition switch ON	When RESUME/ACCELERATE switch is pressed.	On
		When RESUME/ACCELERATE switch is not pressed.	Off
DISTANCE SW	Ignition switch ON	When DISTANCE switch is pressed.	On
		When DISTANCE switch is not pressed.	Off
CRUISE OPE	Drive the vehicle and activate the ICC system	When ICC system is controlling.	On
		When ICC system is not controlling.	Off
BRAKE SW	Ignition switch ON	When brake or clutch pedal is depressed.	Off
		When brake or clutch pedal is not depressed.	On
STOP LAMP SW	Ignition switch ON	When brake pedal is depressed.	On
		When brake pedal is not depressed.	Off
IDLE SW	Engine running	Idling	On
		Except idling (depress accelerator pedal)	Off
SET DISTANCE	<ul style="list-style-type: none"> • Start the engine and turn the ICC system ON • Press the DISTANCE switch to change the vehicle-to-vehicle distance setting 	When set to "long"	Long
		When set to "middle"	Mid
		When set to "short"	Short
CRUISE LAMP	Start the engine and press MAIN switch	ICC system ON (MAIN switch indicator ON).	On
		ICC system OFF (MAIN switch indicator OFF).	Off
OWN VHCL	NOTE: The item is indicated, but not monitored		Off
VHCL AHEAD	Drive the vehicle and activate the ICC system	When a vehicle ahead is detected (vehicle ahead detection indicator ON).	On
		When a vehicle ahead is not detected (vehicle ahead detection indicator OFF).	Off
ICC WARNING	Start the engine and press MAIN switch	When ICC system is malfunctioning (ICC system malfunction ON).	On
		When ICC system is normal (ICC system malfunction OFF).	Off

ADAS CONTROL UNIT

< ECU DIAGNOSIS INFORMATION >

[WITH ICC]

Monitor item	Condition		Value/Status
VHCL SPEED SE	While driving		Displays the vehicle speed calculated by ADAS control unit
SET VHCL SPD	While driving	When vehicle speed is set.	Displays the set vehicle speed
BUZZER O/P	Engine running	When the buzzer of the following system operates: • ICC system • PFCW system • FEB system	On
		When the buzzer of the following system not operates: • ICC system • PFCW system • FEB system	Off
THRTL SENSOR	NOTE: The item is indicated, but not monitored.		0.0
ENGINE RPM	Engine running		Equivalent to tachometer reading
WIPER SW	Ignition switch ON	Wiper not operating.	Off
		Wiper LO operation.	Low
		Wiper HI operation.	High
YAW RATE	NOTE: The item is indicated, but not monitored.		0.0
BA WARNING	Engine running	FEB OFF indicator lamp ON. • When FEB system is malfunctioning. • When FEB system is turned to OFF.	On
		FEB OFF indicator lamp OFF. • When FEB system is normal. • When FEB system is turned to ON.	Off
STP LMP DRIVE	Drive the vehicle and activate the ICC system	When ICC brake hold relay is activated.	On
		When ICC brake hold relay is not activated.	Off
D POSITION SW	Engine running	When the selector lever is in "D" position or manual mode.	On
		When the selector lever is in any position other than "D" or manual mode.	Off
NP RANGE SW	Engine running	When the selector lever is in "N", "P" position.	On
		When the selector lever is in any position other than "N", "P".	Off
PKB SW	Ignition switch ON	When the parking brake is applied.	On
		When the parking brake is released.	Off
PWR SUP MONI	Engine running		Power supply voltage value of ADAS control unit
VHCL SPD AT	While driving		Value of CVT vehicle speed sensor signal
THRTL OPENING	Engine running	Depress accelerator pedal.	Displays the throttle position
GEAR	While driving		Displays the gear position

A
B
C
D
E

BRC

G
H

I
J

K

L

M

N

O

P

ADAS CONTROL UNIT

< ECU DIAGNOSIS INFORMATION >

[WITH ICC]

Monitor item	Condition		Value/Status
CLUTCH SW SIG	Ignition switch ON	When clutch or brake pedal is depressed.	On
		When clutch or brake pedal is not depressed.	Off
NP SW SIG	Ignition switch ON	When the shift lever is in neutral position.	On
		When the shift lever is in any position other than neutral.	Off
MODE SIG	Start the engine and press MAIN switch	When ICC system is deactivated.	Off
		When ICC system is activated.	ICC
SET DISP IND	Press SET/COAST switch	SET switch indicator ON.	On
		SET switch indicator OFF.	Off
DISTANCE	Drive the vehicle and activate the ICC system	When a vehicle ahead is detected.	Displays the distance from the preceding vehicle
		When a vehicle ahead is not detected.	0.0
RELATIVE SPD	Drive the vehicle and activate the ICC system	When a vehicle ahead is detected.	Displays the relative speed.
		When a vehicle ahead is not detected.	0.0
ON ROOT GUIDE	NOTE: The item is indicated, but not monitored.		Off
FCW SYSTEM ON	Ignition switch ON	When the PFCW system is ON.	On
		When the PFCW system is OFF.	Off
Shift position	<ul style="list-style-type: none"> • Engine running • While driving 		Displays the shift position
Turn signal	Turn signal lamps OFF.		Off
	Turn signal lamp LH blinking.		LH
	Turn signal lamp RH blinking.		RH
	Turn signal lamp LH and RH blinking.		LH&RH
SIDE G	While driving	Vehicle turning right.	Negative value
		Vehicle turning left.	Positive value
FUNC ITEM	Ignition switch ON		FUNC3
FUNC ITEM (FCW)	Engine running		On
FUNC ITEM (BSW)	Engine running		On
FUNC ITEM (NV-ICC)	NOTE: The item is indicated, but not monitored		Off
FCW SELECT	Ignition switch ON	"Forward Emergency Braking" set with the integral switch is ON.	On
		"Forward Emergency Braking" set with the integral switch is OFF.	Off
BSW SELECT	Ignition switch ON	"Blind Spot Warning" set with the integral switch is ON.	On
		"Blind Spot Warning" set with the integral switch is OFF.	Off
NAVI ICC SELECT	NOTE: The item is indicated, but not monitored.		Off
SYS SELECTABILITY	Ignition switch ON	Items set with the integral switch can be switched normally.	On
		Items set with the integral switch cannot be switched normally.	Off
BSW WARN LMP	Engine running	When the BSW system is malfunctioning.	On
		When the BSW system is normal.	Off

ADAS CONTROL UNIT

< ECU DIAGNOSIS INFORMATION >

[WITH ICC]

Monitor item	Condition		Value/Status
BSW SYSTEM ON	Ignition switch ON	When the BSW system is ON.	On
		When the BSW system is OFF.	Off
FCW SYSTEM ON	Engine running	When the FEB/PFCW system is ON.	On
		When the FEB/PFCW system is OFF.	Off
BATTERY CIRCUIT OFF	NOTE: The item is indicated, but not used.		Off
SYSTEM CANCEL MESSAGE	Engine running	System cancel display ON.	On
		System cancel display OFF.	Off
BSW ON INDICATOR	Engine running	BSW system display ON.	On
		BSW system display OFF.	Off
SIDE RADAR BLOCK COND	Engine running	Front bumper or side radar is dirty.	On
		Front bumper and side radar is clean.	Off
BSW IND BRIGHTNESS	Ignition switch ON	BSW system OFF.	Nothing
		Blind Spot Warning indicator brightness bright.	Bright
		Blind Spot Warning indicator brightness normal.	Normal
		Blind Spot Warning indicator brightness dark.	Dark
SL MAIN SW	Engine running	When speed limiter MAIN switch is pressed.	On
		When speed limiter MAIN switch is not pressed.	Off
FUNC ITEM (FEB)	Engine running		On
FEB SELECT	Ignition switch ON	"Forward Emergency Braking" set with the integral switch is ON.	On
		"Forward Emergency Braking" set with the integral switch is OFF.	Off
FEB SW	Engine running	FEB system ON.	On
		FEB system OFF.	Off
SL TARGET VEHI-CLE SPEED	While driving	When vehicle speed is set.	Displays the set vehicle speed
SL SET LAMP	<ul style="list-style-type: none"> • Drive the vehicle and activate the speed limiter • Press speed limiter MAIN switch 	Speed limiter SET indicator ON.	On
		Speed limiter SET indicator OFF.	Off
SL LIMIT LAMP	<ul style="list-style-type: none"> • Drive the vehicle and activate the speed limiter • Press speed limiter MAIN switch 	Speed limiter system ON.	On
		Speed limiter system OFF.	Off
ASCDCANCEL (LOW SPEED)	Drive the vehicle and activate the ASCD	ASCDCancelled by low vehicle speed.	On
		Other than above.	Off
ASCDCANCEL (SPEED DIFF)	Drive the vehicle and activate the ASCD	ASCDCancelled by difference between set speed and vehicle speed.	On
		Other than above.	Off
KICK DOWN	Drive the vehicle and activate the speed limiter	When accelerator pedal is full depressed.	On
		Other than above.	Off

A
B
C
D
E
BRC
G
H
I
J
K
L
M
N
O
P

ADAS CONTROL UNIT

< ECU DIAGNOSIS INFORMATION >

[WITH ICC]

TERMINAL LAYOUT

PHYSICAL VALUES

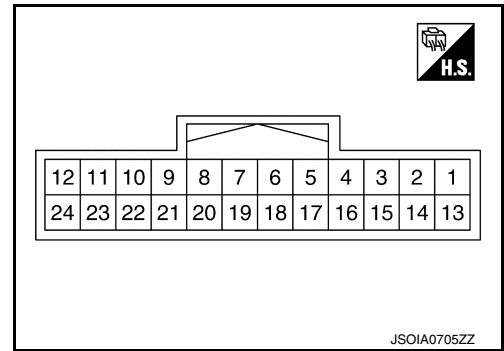

Terminal No. (Wire color)		Description		Condition		Value (Approx.)	
+	-	Signal name	Input/ Output				
1 (B)	Ground	Ground	Input	—		0 V	
2 (L)		ITS communication-High	—	—		—	
3 (LG)		Ignition power supply	Input	Ignition switch ON		Battery voltage	
4 (V)		Warning buzzer signal	Output	Ignition switch ON	Warning buzzer operation	Battery voltage	
					Warning buzzer not operating	0 V	
5 (Y)		ITS communication-Low	—	—		—	
6 (Y)		3rd CAN Low	Input	—		—	
9 (L)		CAN high	—	—		—	
10 (P)		CAN low	—	—		—	
14 (L)		ICC brake hold relay drive signal	Output	Ignition switch ON	—		Battery voltage
18 (L)		3rd CAN High	Input	—	—		0 V

Fail-safe (ADAS Control Unit)

INFOID:000000013504705

If a malfunction occurs in each system, ADAS control unit cancels each control, sounds a beep, and turns ON the warning or indicator lamp.

System	Buzzer	Warning lamp/Warning display	Description
Intelligent Cruise Control (ICC)	High-pitched tone	ICC system warning	Cancel
Forward Emergency Braking (FEB)	High-pitched tone	FEB warning lamp (Yellow)	Cancel
Predictive Forward Collision Warning (PFCW)	High-pitched tone	FEB warning lamp (Yellow)	Cancel
Blind Spot Warning (BSW)	Low-pitched tone	BSW system warning	Cancel
Rear Cross Traffic Alert (BSW)	—	BSW system warning	Cancel

ADAS CONTROL UNIT

< ECU DIAGNOSIS INFORMATION >

[WITH ICC]

DTC Inspection Priority Chart

INFOID:000000013504706

If multiple DTCs are detected simultaneously, check them one by one depending on the following DTC inspection priority chart.

Priority	Detected items (DTC)
1	<ul style="list-style-type: none"> • U1507: LOST COMM (SIDE RDR R) • U1508: LOST COMM (SIDE RDR L)
2	<ul style="list-style-type: none"> • U1000: CAN COMM CIRCUIT • U1321: CONFIGURATION
3	<ul style="list-style-type: none"> • C1A17: ICC SENSOR MALF • C1B53: SIDE RDR R MALF • C1B54: SIDE RDR L MALF
4	<ul style="list-style-type: none"> • C1A01: POWER SUPPLY CIR • C1A02: POWER SUPPLY CIR 2 • C1A13: STOP LAMP RLY FIX • C1A14: ECM CIRCUIT • C1A34: COMMAND ERROR • U0121: VDC CAN CIR 2 • U0235: ICC SENSOR CAN CIRC 1 • U0401: ECM CAN CIR 1 • U0402: TCM CAN CIR 1 • U0415: VDC CAN CIR 1 • U0433: ICC SENSOR CAN CIRC 2 • U1503: SIDE RDR L CAN CIR 2 • U1504: SIDE RDR L CAN CIR 1 • U1505: SIDE RDR R CAN CIR 2 • U1506: SIDE RDR R CAN CIR 1
5	<ul style="list-style-type: none"> • C1A03: VHCL SPEED SE CIRC
6	<ul style="list-style-type: none"> • C1A00: CONTROL UNIT

A
B
C
D
E
G
H
I
J
K
L
M
N
O
P

BRC

DTC Index

INFOID:000000013504707

Systems for fail-safe

- A: Intelligent Cruise Control (ICC)
- B: Forward Emergency Braking (FEB)
- C: Predictive Forward Collision Warning (PFCW)
- D: Blind Spot Warning (BSW)
- E: Rear Cross Traffic Alert (RCTA)

DTC	CONSULT display	Fail-safe	Reference
		System	
NO DTC IS DETECTED. FURTHER TESTING MAY BE REQUIRED	NO DTC IS DETECTED. FURTHER TESTING MAY BE REQUIRED	—	—
U1507	LOST COMM (SIDE RDR R)	D, E	DAS-74
U1508	LOST COMM (SIDE RDR L)	D, E	DAS-75
U1000 ^{NOTE}	CAN COMM CIRCUIT	A, B, C, D, E	DAS-63
U1321	CONFIGURATION	A, B, C, D, E	DAS-66
C1A17	ICC SENSOR MALF	A, B, C	DAS-47
C1B53	SIDE RDR R MALF	D, E	DAS-51
C1B54	SIDE RDR L MALF	D, E	DAS-52
C1A01	POWER SUPPLY CIR	A, B, C, D, E	DAS-37
C1A02	POWER SUPPLY CIR 2	A, B, C, D, E	DAS-37

ADAS CONTROL UNIT

< ECU DIAGNOSIS INFORMATION >

[WITH ICC]

Systems for fail-safe

- A: Intelligent Cruise Control (ICC)
- B: Forward Emergency Braking (FEB)
- C: Predictive Forward Collision Warning (PFCW)
- D: Blind Spot Warning (BSW)
- E: Rear Cross Traffic Alert (RCTA)

DTC	CONSULT display	Fail-safe	Reference
CONSULT		System	
C1A13	STOP LAMP RLY FIX	A, B, C	DAS-40
C1A14	ECM CIRCUIT	A, B, C	DAS-47
C1A34	COMMAND ERROR	A, B, C	DAS-50
U0121	VDC CAN CIR 2	A, B, C, D, E	DAS-53
U0235	ICC SENSOR CAN CIRC 1	A, C, D, E	DAS-55
U0401	ECM CAN CIR 1	A, B, C, D, E	DAS-56
U0402	TCM CAN CIR 1	A, B, C, D, E	DAS-58
U0415	VDC CAN CIR 1	A, B, C, D, E	DAS-60
U0433	ICC SENSOR CAN CIRC 2	A, B, C	DAS-62
U1503	SIDE RDR L CAN CIR 2	D, E	DAS-66
U1504	SIDE RDR L CAN CIR 1	D, E	DAS-68
U1505	SIDE RDR R CAN CIR 2	D, E	DAS-70
U1506	SIDE RDR R CAN CIR 1	D, E	DAS-72
C1A03	VHCL SPEED SE CIRC	D, E	DAS-38
C1A00	CONTROL UNIT	A, B, C, D, E	DAS-36

NOTE:

With the detection of “U1000” some systems do not perform the fail-safe operation.

A system controlling based on a signal received from the control unit performs fail-safe operation when the communication with the ADAS control unit becomes inoperable.

BRAKE CONTROL SYSTEM

[WITH ICC]

< WIRING DIAGRAM >

WIRING DIAGRAM

BRAKE CONTROL SYSTEM

Wiring Diagram

INFOID:000000012894556

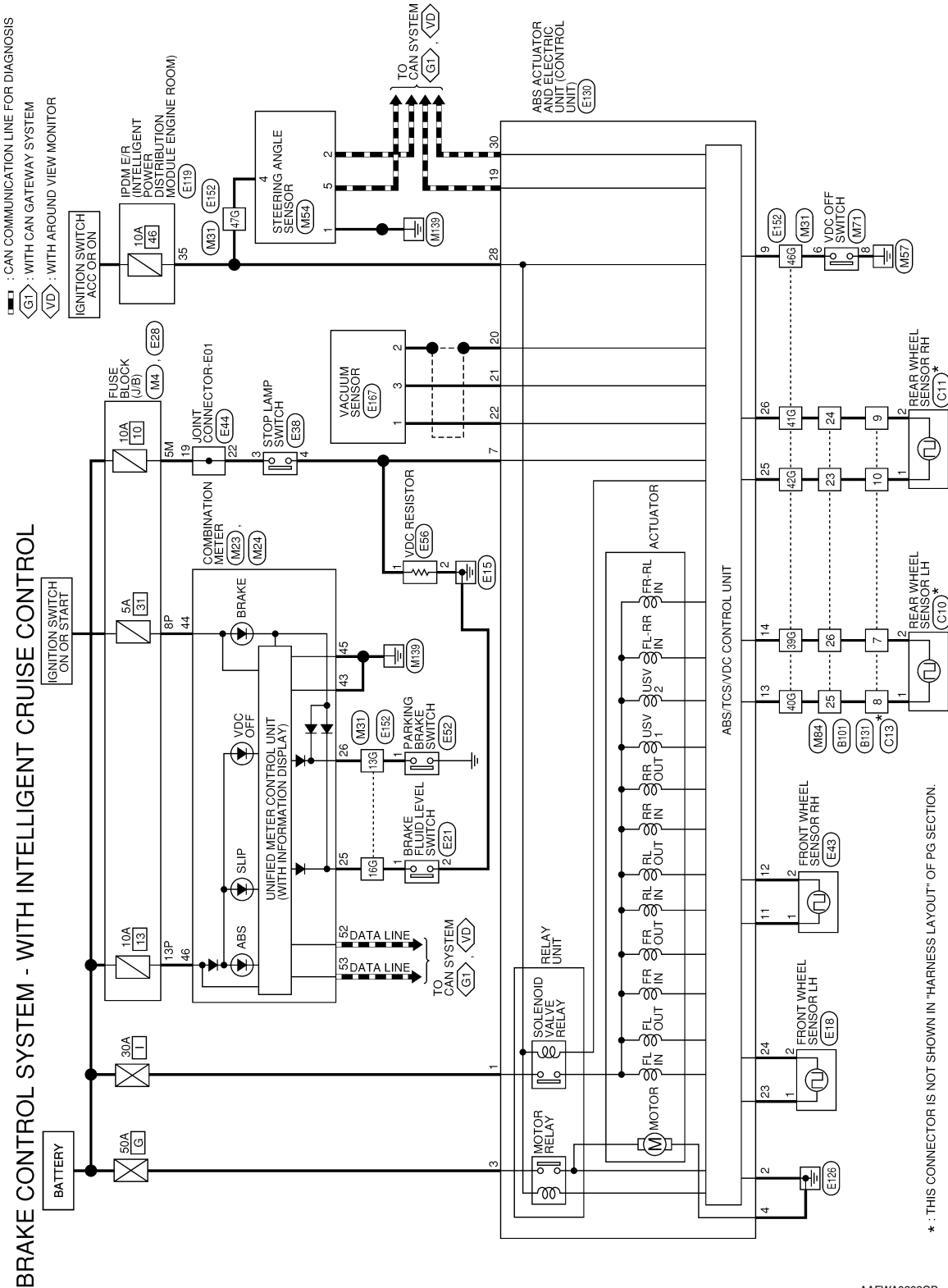

AAFWA0208GB

A
B
C
D
E
BRC
G
H
I
J
K
L
M
N
O
P

BRAKE CONTROL SYSTEM

< WIRING DIAGRAM >

[WITH ICC]

BRAKE CONTROL SYSTEM CONNECTORS - WITH INTELLIGENT CRUISE CONTROL

Connector No.	M4
Connector Name	FUSE BLOCK (J/B)
Connector Type	NS16FW-CS
Connector Color	WHITE

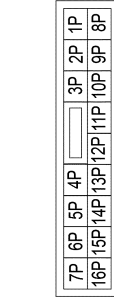

Terminal No.	Color of Wire	Signal Name
8P	BG	-
13P	W	-

Connector No.	M23
Connector Name	COMBINATION METER
Connector Type	TH16FW-NH
Connector Color	WHITE

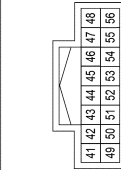

Terminal No.	Color of Wire	Signal Name
43	B	GND1
44	BG	POWER (IGN)
45	B	GND2
46	W	POWER (BAT)
52	P	CAN-L
53	L	CAN-H

Connector No.	M24
Connector Name	COMBINATION METER
Connector Type	TH40FW-NH
Connector Color	WHITE

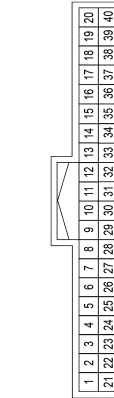

Terminal No.	Color of Wire	Signal Name
25	G	BRAKE OIL SW
26	BR	PKB SW

Connector No.	M31
Connector Name	WIRE TO WIRE
Connector Type	TH80FW-CS16-TM4
Connector Color	WHITE

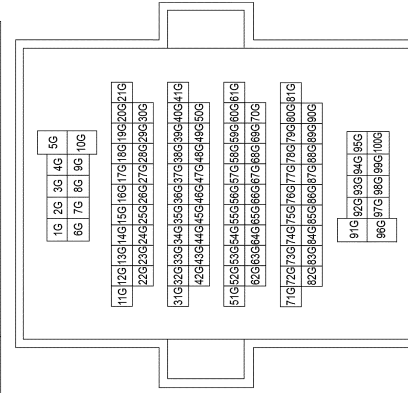

Terminal No.	Color of Wire	Signal Name
13G	BR	-
16G	G	-
39G	W	-
40G	B	-
41G	P	-
42G	V	-
46G	P	-

47G	G	-
Connector No.	M54	
Connector Name	STEERING ANGLE SENSOR	
Connector Type	TH08FW-NH	
Connector Color	WHITE	

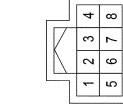

Terminal No.	Color of Wire	Signal Name
1	GR	STEERING SENSOR GND
2	P	CAN-L
4	G	STEERING SENSOR POWER SUPPLY
5	L	CAN-H

Connector No.	M71
Connector Name	VDC OFF SWITCH
Connector Type	TH08FB-NH
Connector Color	BLACK

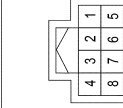

Terminal No.	Color of Wire	Signal Name
6	P	-
8	B	-

BRAKE CONTROL SYSTEM

< WIRING DIAGRAM >

[WITH ICC]

2	Y	-
Connector No.	E44	
Connector Name	JOINT CONNECTOR-E01	
Connector Type	BJ30FW	
Connector Color	WHITE	

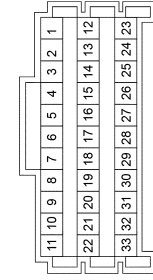

Terminal No.	Color of Wire	Signal Name
19	W	-
22	W	-

Connector No.	E52
Connector Name	PARKING BRAKE SWITCH
Connector Type	P01FB-A
Connector Color	BLACK



Terminal No.	Color of Wire	Signal Name
1	LG	-

2	B	-
Connector No.	E28	
Connector Name	FUSE BLOCK (J/B)	
Connector Type	NS10FW-CS	
Connector Color	WHITE	

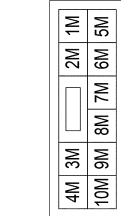

Terminal No.	Color of Wire	Signal Name
5M	W	-

Connector No.	E38
Connector Name	STOP LAMP SWITCH
Connector Type	M04FW-LC
Connector Color	WHITE



Terminal No.	Color of Wire	Signal Name
3	W	-(WITH ICC)
4	G	-(WITH ICC)

Connector No.	E43
Connector Name	FRONT WHEEL SENSOR RH
Connector Type	RH02MB
Connector Color	BLACK



Terminal No.	Color of Wire	Signal Name
1	L	-

Connector No.	M84
Connector Name	WIRE TO WIRE
Connector Type	TH32FW-NH
Connector Color	WHITE

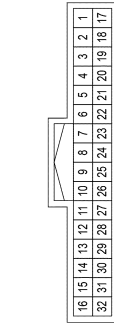

Terminal No.	Color of Wire	Signal Name
23	V	-
24	P	-
25	B	-
26	W	-

Connector No.	E18
Connector Name	FRONT WHEEL SENSOR LH
Connector Type	RH02MB
Connector Color	BLACK



Terminal No.	Color of Wire	Signal Name
1	G	-
2	W	-

Connector No.	E21
Connector Name	BRAKE FLUID LEVEL SWITCH
Connector Type	YV02FGY
Connector Color	GRAY



Terminal No.	Color of Wire	Signal Name
1	W	-

AAFIA0479GB

A
B
C
D
E
BRC
G
H
I
J
K
L
M
N
O
P

BRAKE CONTROL SYSTEM

< WIRING DIAGRAM >

[WITH ICC]

Connector No.	B131
Connector Name	WIRE TO WIRE
Connector Type	RH12FB
Connector Color	BLACK

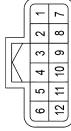

Terminal No.	Color of Wire	Signal Name
7	W	-
8	B	-
9	P	-
10	V	-

2	P	-
---	---	---

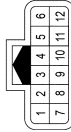

Connector No.	C13
Connector Name	WIRE TO WIRE
Connector Type	RH12MB
Connector Color	BLACK

Terminal No.	Color of Wire	Signal Name
7	W	-
8	B	-
9	P	-
10	V	-

Connector No.	B101
Connector Name	WIRE TO WIRE
Connector Type	TH32MW-NH
Connector Color	WHITE

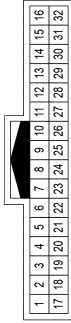

Terminal No.	Color of Wire	Signal Name
23	V	-
24	P	-
25	B	-
26	W	-

Connector No.	E167
Connector Name	VACUUM SENSOR
Connector Type	RH03FB
Connector Color	BLACK

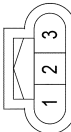

Terminal No.	Color of Wire	Signal Name
1	W	-
2	SHIELD	-
3	B	-

Connector No.	C10
Connector Name	REAR WHEEL SENSOR LH
Connector Type	RH02MB
Connector Color	BLACK



Terminal No.	Color of Wire	Signal Name
1	B	-
2	W	-

Connector No.	C11
Connector Name	REAR WHEEL SENSOR RH
Connector Type	RH02MGY
Connector Color	GRAY



Terminal No.	Color of Wire	Signal Name
1	V	-

AAFIA0481GB

A
B
C
D
E
BRC
G
H
I
J
K
L
M
N
O
P

BASIC INSPECTION

DIAGNOSIS AND REPAIR WORK FLOW

Work Flow

INFOID:0000000012894557

DETAILED FLOW

1. INTERVIEW THE CUSTOMER

Clarify customer concerns before inspection. First of all, perform an interview utilizing [BRC-243, "Diagnostic Work Sheet"](#) and reproduce the symptom as well as fully understand it. Ask customer about his/her concerns carefully. Check symptoms by driving vehicle with customer, if necessary.

CAUTION:

Customers are not professional. Never guess easily like "maybe the customer means that..." or "maybe the customer mentions this symptom".

>> GO TO 2.

2. CHECK SYMPTOM

Reproduce the symptom that is indicated by the customer, based on the information from the customer obtained in the interview. Also check that the symptom is not caused by fail-safe mode. Refer to [BRC-225, "Fail-Safe"](#).

CAUTION:

When the symptom is caused by normal operation, fully inspect each portion and obtain the understanding of customer that the symptom is not caused by a malfunction.

>> GO TO 3.

3. PERFORM THE SELF-DIAGNOSIS

ⓐ With CONSULT

1. Turn the ignition switch OFF → ON.

CAUTION:

Be sure to wait of 10 seconds after turning ignition switch OFF or ON.

2. Perform "Self Diagnostic Result" of "ABS".

Is DTC detected?

YES >> Record or print Self Diagnostic Results and Freeze Frame Data (FFD). GO TO 4.

NO >> GO TO 6.

4. RECHECK THE SYMPTOM

ⓐ With CONSULT

1. Erase "Self Diagnostic Result" of "ABS".
2. Turn the ignition switch OFF → ON → OFF.

CAUTION:

Be sure to wait of 10 seconds after turning ignition switch OFF or ON.

3. Perform DTC confirmation procedures for the malfunctioning system.

NOTE:

If some DTCs are detected at the same time, determine the order for performing the diagnosis based on [BRC-227, "DTC Inspection Priority Chart"](#).

Is DTC detected?

YES >> GO TO 5.

NO >> Check harness and connectors based on the information obtained in the interview. Refer to [GI-42, "Intermittent Incident"](#).

5. REPAIR OR REPLACE MALFUNCTIONING COMPONENT

1. Repair or replace malfunctioning components.
2. Reconnect component or connector after repairing or replacing.
3. When DTC is detected, erase "Self Diagnostic Result" of "ABS".

CAUTION:

DIAGNOSIS AND REPAIR WORK FLOW

[WITH ICC]

< BASIC INSPECTION >

- Turn the ignition switch OFF → ON → OFF after erasing Self Diagnostic Result.
- Be sure to wait of 10 seconds after turning ignition switch OFF or ON.

>> GO TO 7.

6. IDENTIFY MALFUNCTIONING SYSTEM BY SYMPTOM DIAGNOSIS

Identify malfunctioning system based on symptom diagnosis and perform inspection.

Can the malfunctioning system be identified?

YES >> GO TO 7.

NO >> Check harness and connectors based on the information obtained in the interview. Refer to [GI-42](#), "[Intermittent Incident](#)".

7. FINAL CHECK

④ With CONSULT

1. Select "DATA MONITOR" of "ABS"
2. Check the reference values. Refer to [BRC-222](#), "[Reference Value](#)".
3. Recheck the symptom and check that the symptom is not reproduced on the same conditions.

Is the symptom reproduced?

YES >> GO TO 3.

NO >> Inspection End.





Diagnostic Work Sheet

INFOID:000000012894558

DESCRIPTION

- In general, customers have their own criteria for a problem. Therefore, it is important to understand the symptom and status well enough by asking the customer about his/her concerns carefully. To systemize all the information for the diagnosis, prepare the interview sheet referring to the interview points.
- In some cases, multiple conditions that appear simultaneously may cause a DTC to be detected.

INTERVIEW SHEET SAMPLE

Interview sheet					
Customer name	MR/MS	Registration number		Initial year registration	
		Vehicle type		VIN	
Storage date		Engine/traction Motor		Mileage	km (Mile)
Symptom	<input type="checkbox"/> Does not operate () function				
	<input type="checkbox"/> Warning lamp turns ON.				
	ABS  or BRAKE  or    OFF				
	<input type="checkbox"/> Other ()				
	<input type="checkbox"/> Noise (Location:) <input type="checkbox"/> Vibration (Location:)				
<input type="checkbox"/> Other ()					
First occurrence	<input type="checkbox"/> Recently <input type="checkbox"/> Other ()				
Frequency of occurrence	<input type="checkbox"/> Always <input type="checkbox"/> Under a certain conditions of <input type="checkbox"/> Sometimes (time(s)/day)				
Climate conditions	<input type="checkbox"/> Irrelevant				
	Weather	<input type="checkbox"/> Fine <input type="checkbox"/> Cloud <input type="checkbox"/> Rain <input type="checkbox"/> Snow <input type="checkbox"/> Others ()			
	Temperature	<input type="checkbox"/> Hot <input type="checkbox"/> Warm <input type="checkbox"/> Cool <input type="checkbox"/> Cold <input type="checkbox"/> Temperature [Approx. °C (°F)]			
Relative humidity	<input type="checkbox"/> High <input type="checkbox"/> Moderate <input type="checkbox"/> Low				
Road conditions	<input type="checkbox"/> Ordinary road <input type="checkbox"/> Highway <input type="checkbox"/> Mountainous road (uphill or downhill) <input type="checkbox"/> Rough road				

DIAGNOSIS AND REPAIR WORK FLOW

< BASIC INSPECTION >

[WITH ICC]

Interview sheet

Customer name	MR/MS	Registration number		Initial year registration	
		Vehicle type		VIN	
Storage date		Engine/traction Motor		Mileage	km (Mile)
Operating condition, etc.		<input type="checkbox"/> Irrelevant <input type="checkbox"/> When engine/traction motor starts <input type="checkbox"/> During idling <input type="checkbox"/> During driving <input type="checkbox"/> During acceleration <input type="checkbox"/> At constant speed driving <input type="checkbox"/> During deceleration <input type="checkbox"/> Immediately before stop [Vehicle speed: Approx. km/h (MPH)] <input type="checkbox"/> During cornering (right curve or left curve) <input type="checkbox"/> When steering wheel is steered (to right or to left)			
		<input type="checkbox"/> Yes <input type="checkbox"/> No			
Other conditions	VDC OFF switch operation	<input type="checkbox"/> Yes <input type="checkbox"/> No			
	Use of other functions (ex. ICC)	<input type="checkbox"/> Yes <input type="checkbox"/> No ()			
	Presence of non-genuine parts installation	<input type="checkbox"/> Yes <input type="checkbox"/> No ()			

Memo

ADDITIONAL SERVICE WHEN REPLACING ABS ACTUATOR AND ELECTRIC UNIT (CONTROL UNIT)

< BASIC INSPECTION >

[WITH ICC]

ADDITIONAL SERVICE WHEN REPLACING ABS ACTUATOR AND ELECTRIC UNIT (CONTROL UNIT)

Description

INFOID:000000012894559

- When replacing the ABS actuator and electric unit (control unit), perform configuration of the ABS actuator and electric unit (control unit). Refer to [BRC-251, "Work Procedure"](#).
- When replacing the ABS actuator and electric unit (control unit), adjust the neutral position of steering angle sensor. Refer to [BRC-247, "Work Procedure"](#).
- When replacing the ABS actuator and electric unit (control unit), perform calibration of the decel G sensor. Refer to [BRC-249, "Work Procedure"](#).

A
B
C
D
E
G
H
I
J
K
L
M
N
O
P

BRC

ADDITIONAL SERVICE WHEN REPLACING ICC SENSOR

< BASIC INSPECTION >

[WITH ICC]

ADDITIONAL SERVICE WHEN REPLACING ICC SENSOR

Description

INFOID:000000012894560

- Always perform the radar alignment aiming adjustment after removing and installing or replacing the ICC sensor.

CAUTION:

The system does not operate normally unless the ICC sensor is aligned properly.

- Perform the ICC system action test to check that the ICC system operates normally.

Work Procedure

INFOID:000000012894561

1. RADAR ALIGNMENT ADJUSTMENT

Adjust the radar alignment. Refer to [BRC-255. "Description"](#).

>> GO TO 2.

2. ICC SYSTEM ACTION TEST

-
1. Perform the ICC system action test. Refer to [EC-70. "CONSULT Function"](#).
 2. Check that the ICC system operates normally.

>> Inspection End.

ADJUSTMENT OF STEERING ANGLE SENSOR NEUTRAL POSITION

< BASIC INSPECTION >

[WITH ICC]

ADJUSTMENT OF STEERING ANGLE SENSOR NEUTRAL POSITION

Description

INFOID:0000000012894562

Refer to the table below to determine if adjustment of steering angle sensor neutral position is required.

x: Required -: Not required

Situation	Adjustment of steering angle sensor neutral position
Removing/Installing ABS actuator and electric unit (control unit)	—
Replacing ABS actuator and electric unit (control unit)	x
Removing/Installing steering angle sensor	x
Replacing steering angle sensor	x
Removing/Installing steering components	x
Replacing steering components	x
Removing/Installing suspension components	—
Replacing suspension components	x
Changing tires to new ones	—
Tire rotation	—
Adjusting wheel alignment	x

Work Procedure

INFOID:0000000012894563

ADJUSTMENT OF STEERING ANGLE SENSOR NEUTRAL POSITION

CAUTION:

To adjust neutral position of steering angle sensor, make sure to use CONSULT. (Adjustment cannot be done without CONSULT).

1. ALIGN THE VEHICLE STATUS

Stop vehicle with front wheels in straight-ahead position.

>> GO TO 2.

2. PERFORM THE NEUTRAL POSITION ADJUSTMENT FOR THE STEERING ANGLE SENSOR

1. On the CONSULT screen, touch "Work support" and "ST ANGLE SENSOR ADJUSTMENT" in order.
2. Touch "Start".

CAUTION:

Do not touch steering wheel while adjusting steering angle sensor.

3. After approximately 10 seconds, touch "End".

NOTE:

After approximately 60 seconds, it ends automatically.

4. Turn ignition switch OFF then turn it ON again.

CAUTION:

Be sure to perform above operation.

>> GO TO 3.

3. CHECK DATA MONITOR

1. Run vehicle with front wheels in straight-ahead position then stop.
2. Select "Data Monitor". Then make sure "STR ANGLE SIG" is within $0 \pm 3.5^\circ$.

Is the steering angle within the specified range?

YES >> GO TO 4.

NO >> Perform the neutral position adjustment for the steering angle sensor again GO TO 1.

4. ERASE THE SELF DIAGNOSTIC RESULT MEMORY

Erase the "Self Diagnostic Result" memory of the ABS actuator and electric unit (control unit) and ECM.

- ABS actuator and electric unit (control unit): Refer to [BRC-39, "CONSULT Function"](#).

ADJUSTMENT OF STEERING ANGLE SENSOR NEUTRAL POSITION

< BASIC INSPECTION >

[WITH ICC]

- ECM: Refer to [EC-70. "CONSULT Function"](#).

Are the memories erased?

YES >> Inspection End.

NO >> Check the items indicated by the "Self Diagnostic Result".

CALIBRATION OF DECEL G SENSOR

< BASIC INSPECTION >

[WITH ICC]

CALIBRATION OF DECEL G SENSOR

Description

INFOID:000000012894564

CAUTION:

Always perform the decel G sensor calibration before driving when the following operation is performed.

NOTE:

Yaw rate/side/decel G sensor calibration is performed when performing the decel G sensor calibration.

x: Required —: Not required

Procedure	Decel G sensor calibration
Removing/ installing ABS actuator and electric unit (control unit)	—
Replacing ABS actuator and electric unit (control unit)	x
Removing/installing steering components	—
Replacing steering components	—
Removing/installing suspension components	—
Replacing suspension components	—
Removing/installing tire	—
Replacing tire	—
Tire rotation	—
Adjusting wheel alignment	—

Work Procedure

INFOID:000000012894565

Decel G sensor calibration

CAUTION:

Always use CONSULT for the decel G sensor calibration. (It cannot be adjusted other than with CONSULT.)

NOTE:

Yaw rate/side/decel G sensor calibration is performed when performing the decel G sensor calibration.

1. CHECK THE VEHICLE STATUS

1. Steer the steering wheel to the straight-ahead position. Stop the vehicle on level surface.
2. Stop the engine.
3. Turn the ignition switch OFF.

Is the vehicle stopped in the straight-ahead position on level surface?

YES >> GO TO 2.

NO >> Steer the steering wheel to the straight-ahead position. Stop the vehicle on level surface.

2. PERFORM DECEL G SENSOR CALIBRATION

CAUTION:

- Never allow passenger or load on the vehicle.
- Never apply vibration to the vehicle body when opening or closing door during calibration.

CONSULT

1. Turn the ignition switch ON.

CAUTION:

Never start engine.

2. Select "ABS", "Work support", "DECEL G SEN CALIBRATION" in this order.
3. Select "Start".
4. After approx. 10 seconds, select "End".
5. Turn ignition switch OFF and then turn it ON again.

CAUTION:

Be sure to perform the operation above.

>> GO TO 3.

CALIBRATION OF DECEL G SENSOR

[WITH ICC]

< BASIC INSPECTION >

3. CHECK DATA MONITOR

CONSULT

1. Drive the vehicle. Steer the steering wheel to the straight-ahead position. Stop the vehicle on level surface.
2. Select “ABS”, “Data Monitor”, “ECU INPUT SIGNALS” and “DECEL G SENSOR” in this order. Check that the signal is within the specified value.

DECEL G SENSOR : Approx. ± 0.01 G

Is the inspection result normal?

- YES >> GO TO 4.
NO >> GO TO 1.

4. ERASE SELF DIAGNOSTIC RESULT MEMORY

CONSULT

Erase “Self Diagnostic Result” of “ABS”.

Are the memories erased?

- YES >> Inspection End.
NO >> Check the items indicated by the “Self Diagnostic Result”.

CONFIGURATION [ABS ACTUATOR AND ELECTRIC UNIT (CONTROL UNIT)]

[WITH ICC]

< BASIC INSPECTION >

CONFIGURATION [ABS ACTUATOR AND ELECTRIC UNIT (CONTROL UNIT)]

Work Procedure

INFOID:000000012894566

NOTE:

- After configuration, turn the ignition switch from OFF to ON and check that the VDC warning lamp turns OFF after staying illuminated for approximately two seconds.
- If an error occurs during configuration, start over from the beginning.

1. CHECK TYPE ID (1)

CONSULT

1. Using CONSULT, select "ECU Identification" of "ABS".
2. Write down "ECU PART NUMBER" displayed on the CONSULT screen. This is the ABS actuator and electric unit (control unit) "Type ID".

Is "Type ID" displayed?

YES-1 >> When replacing ABS actuator and electric unit (control unit): GO TO 3.

YES-2 >> When re-configuring existing ABS actuator and electric unit (control unit): GO TO 4.

NO >> GO TO 2.

2. CHECK TYPE ID (2)

1. Use FAST (service parts catalog) to search ABS actuator and electric unit (control unit) of the applicable vehicle and find "Type ID".
2. Write down "Type ID".

>> • When replacing ABS actuator and electric unit (control unit): GO TO 3.

• When re-configuring existing ABS actuator and electric unit (control unit): GO TO 4.

3. REPLACE ABS ACTUATOR AND ELECTRIC UNIT (CONTROL UNIT)

Replace ABS actuator and electric unit (control unit). Refer to [BRC-370. "Removal and Installation"](#).

CAUTION:

Do not perform the following work items at this time. These items must be performed after configuration is complete.

- Air bleeding
- Adjustment of steering angle sensor neutral position
- Calibration of decel G sensor

>> GO TO 4.

4. WRITE CONFIGURATION

CONSULT Configuration

1. Select "Manual Configuration".
2. Select the "Type ID" found using CONSULT "ECU Identification" or FAST (service parts catalog) to write the "Type ID" into the ABS actuator and electric unit (control unit).

>> GO TO 5.

5. VERIFY TYPE ID

Compare the "Type ID" written into the ABS actuator and electric unit (control unit) with the one found using CONSULT "ECU Identification" or FAST (service parts catalog) to confirm they match.

Do Type IDs match?

YES >> GO TO 6.

NO >> GO TO 4.

6. CHECK VDC WARNING LAMP

1. Turn the ignition switch OFF.
2. Turn the ignition switch ON and check that the VDC warning lamp turns OFF after staying illuminated for approximately two seconds.

A
B
C
D
E
BRC
G
H
I
J
K
L
M
N
O
P

CONFIGURATION [ABS ACTUATOR AND ELECTRIC UNIT (CONTROL UNIT)]

[WITH ICC]

< BASIC INSPECTION >

NOTE:

Do not start the engine.

Is the inspection result normal?

YES >> GO TO 7.

NO >> Perform self-diagnosis of "ABS". Refer to [BRC-213, "CONSULT Function"](#).

7.PERFORM SUPPLEMENTARY WORK

1. Perform air bleeding. Refer to [BR-14, "Bleeding Brake System"](#).
2. Perform adjustment of steering angle sensor neutral position. Refer to [BRC-247, "Work Procedure"](#).
3. Perform calibration of decel G sensor. Refer to [BRC-249, "Work Procedure"](#).
4. Perform self-diagnosis of all systems.
5. Erase self-diagnosis results.

>> Work End.

ICC SENSOR INITIAL VERTICAL ALIGNMENT

< BASIC INSPECTION >

[WITH ICC]

ICC SENSOR INITIAL VERTICAL ALIGNMENT

Description

INFOID:000000012894567

WARNING:

Radio waves could adversely affect electric medical equipment. Those who use a pacemaker should contact the electric medical equipment manufacturer for the possible influences before use.

OUTLINE OF ICC SENSOR INITIAL ALIGNMENT PROCEDURE

- Always perform the ICC sensor initial vertical alignment after removing and installing or replacing the ICC sensor.

CAUTION:

The system does not operate normally unless the ICC sensor is aligned properly.

1. Required tools, refer to [BRC-253, "Required Tools"](#).
2. Preparation, refer to [BRC-253, "Preparation"](#).
3. ICC sensor initial vertical alignment, refer to [BRC-254, "ICC Sensor Initial Vertical Alignment"](#).

CAUTIONARY POINT FOR DISTANCE SENSOR ALIGNMENT PROCEDURE

CAUTION:

- For Distance sensor alignment procedure, choose a level location with a few feet of working space in front and surrounding the vehicle.
- Vehicle must be stationary and unoccupied during the whole alignment procedure.
- Never enter the vehicle during ICC sensor alignment.
- For proper system operation and adjustment, all vehicle wheels must be the original factory size.

The ICC sensor requires alignment whenever the ICC sensor is removed and reinstalled and whenever front end structural repairs are performed. ICC sensor alignment consists of performing the mechanical vertical alignment (ICC sensor initial vertical alignment) described in the following procedure, followed by the electronic horizontal alignment (ICC sensor alignment) that is performed using CONSULT and the appropriate special service tools.

Required Tools

INFOID:000000012894568

The following tool is necessary to perform the ICC sensor initial vertical alignment:

- Small level or angle meter.

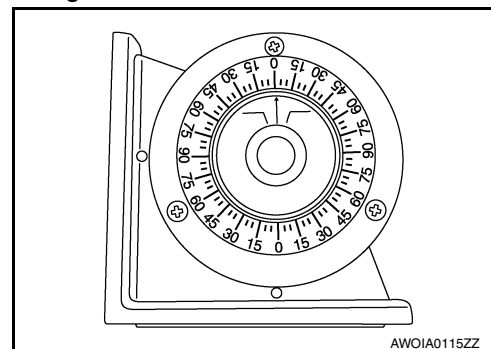

Preparation

INFOID:000000012894569

1. PREPARATION FOR ICC SENSOR INITIAL VERTICAL ALIGNMENT PROCEDURE

1. Verify correct vehicle suspension height. Refer to [FSU-26, "Wheelarch Height \(Unladen*\)"](#).
2. Repair or replace any damaged body components.
3. Verify proper tire inflation pressures. Refer to [WT-72, "Tire Air Pressure"](#).
4. Remove any accumulations of mud, snow or ice from the vehicle underbody.
5. Verify that there is no load in the vehicle (cargo or passenger).
6. Place the vehicle on a known level horizontal surface such as a wheel or frame alignment rack to achieve satisfactory sensor vertical alignment results.

A
B
C
D
E
BRC

G
H
I
J
K
L
M
N

O
P

ICC SENSOR INITIAL VERTICAL ALIGNMENT

< BASIC INSPECTION >

[WITH ICC]

>> Refer to [BRC-254. "ICC Sensor Initial Vertical Alignment"](#).

ICC Sensor Initial Vertical Alignment

INFOID:000000012894570

NOTE:

The ICC sensor initial vertical alignment procedure must be performed anytime the Distance sensor is removed and reinstalled.

1. The ICC sensor (1) is located near the right front head lamp behind the front bumper fascia.

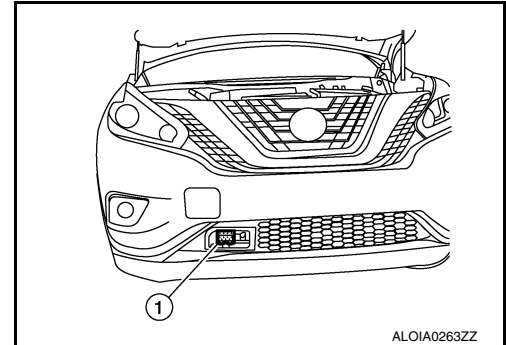

2. Place the small level or angle meter (2) against the face of the ICC sensor (1).

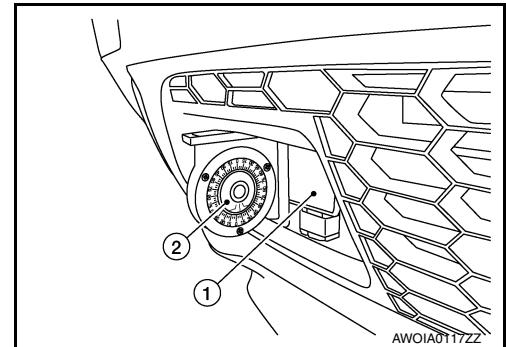

3. Turn the ICC sensor adjustment screw (3) to level the sensor.

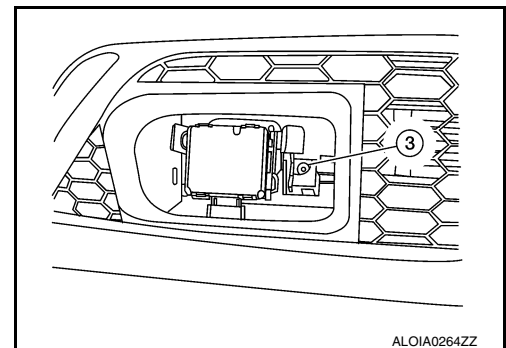

4. Ensure the ICC sensor electrical connector located on the bottom of the sensor is connected.
5. Perform the ICC sensor alignment procedure. Refer to [BRC-255. "Description"](#).

ICC SENSOR ALIGNMENT

< BASIC INSPECTION >

[WITH ICC]

ICC SENSOR ALIGNMENT

Description

INFOID:000000012894571

WARNING:

Radio waves could adversely affect electric medical equipment. Those who use a pacemaker should contact the electric medical equipment manufacturer for the possible influences before use.

OUTLINE OF ICC SENSOR ALIGNMENT PROCEDURE

- A 4-wheel vehicle alignment must be performed before proceeding with ICC sensor alignment procedure.
- Always perform the ICC sensor alignment after removing and installing or replacing the ICC sensor.
- If the ICC sensor was removed and installed or replaced, first perform ICC Sensor Initial Vertical Alignment, refer to [BRC-253, "Description"](#).

CAUTION:

The system does not operate normally unless the ICC sensor is aligned properly.

1. Required tools, refer to [BRC-255, "Required Tools"](#).
2. Preparation, refer to [BRC-256, "Preparation"](#).
3. Vehicle set up, refer to [BRC-257, "Vehicle Set Up"](#).
4. Setting the ICC target board, refer to [BRC-259, "Setting The ICC Target Board"](#).
5. ICC sensor adjustment, refer to [BRC-260, "ICC Sensor Adjustment"](#).

CAUTIONARY POINT FOR ICC SENSOR ALIGNMENT PROCEDURE

CAUTION:

- For ICC sensor alignment procedure, choose a level location with a few feet of working space in front and surrounding the vehicle.
- Vehicle must be stationary and unoccupied during the whole alignment procedure.
- Any slight vibration during the alignment procedure can cause the test to fail. If this happens, you will have to restart the alignment process.
- The ignition switch must be in the ON position.
- The battery voltage must not fall below 12 volts during the whole alignment procedure. Failure to maintain adequate battery voltage will cause the test to fail. If this happens, you will have to restart the alignment process.
- The ICC target board must be set in front of the vehicle facing the sensor.
- Adjust the ICC sensor alignment with CONSULT. (The ICC sensor alignment procedure cannot be adjusted without CONSULT.)
- Never enter the vehicle during ICC sensor alignment.
- Never block the area between the ICC sensor and the ICC target board at any time during the alignment process.
- Never break the laser beam between the laser assembly and front ICC target board or rear reflector at any time during alignment.
- Accurate steering wheel setting is crucial. Once set, do not disturb the steering wheel for the remainder of the alignment procedure.
- To avoid physical damage, the ICC sensor adjustment screw must not be forced to either clockwise or counter-clockwise limit. For proper adjustment procedure, follow the directions of the CONSULT exactly as instructed.
- For proper system operation and adjustment, all vehicle wheels must be of the same size.

Required Tools

INFOID:000000012894572

- ICC alignment kit 1-20-2851-1 in addition to one of the following:
 - a) Hunter self-centering wheel adapter (Hunter wheel alignment tool)
 - b) Special Service Tool kit 1-20-2722-1 (kit SCA W/Tire Clamp-ICC Aiming)

The following ICC alignment kit 1-20-2851-1 is necessary to perform the ICC sensor alignment:

ICC SENSOR ALIGNMENT

[WITH ICC]

< BASIC INSPECTION >

- ICC target board.
 - Position 1, with top tilted 2° toward vehicle (1).
 - Position 2, vertical (2).
 - Position 3, with top tilted 2° away from vehicle (3).

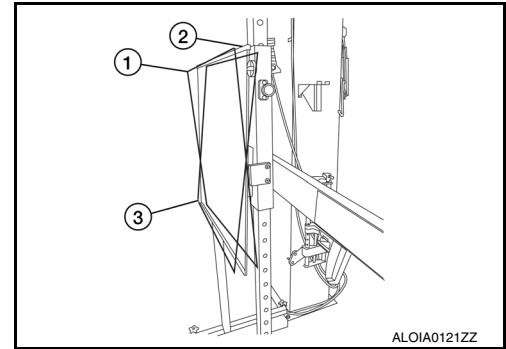

- Hunter self-centering wheel adapter (1) [shown with laser assembly (2) installed] (Hunter alignment rack head may be substituted).

NOTE:

Retailers that are not equipped with a Hunter self-centering wheel adapter will require the following kit:
Part No. 1-20-2722-1 (kit SCA W/Tire Clamp-ICC Aiming)

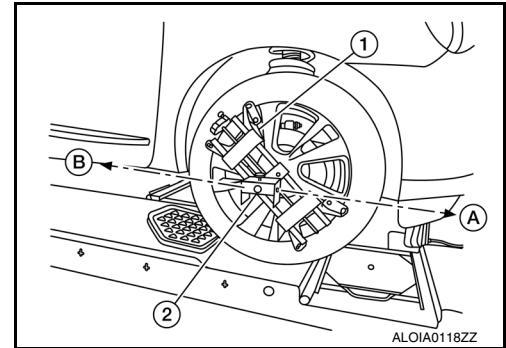

- Laser assembly (with bi-directional laser beam) as shown in the illustration.

- Tightening knob (1)
- Power ON/OFF button (2)
- Front laser beam opening (3)
- Rear laser beam opening (4)
- Attaching shaft (5)

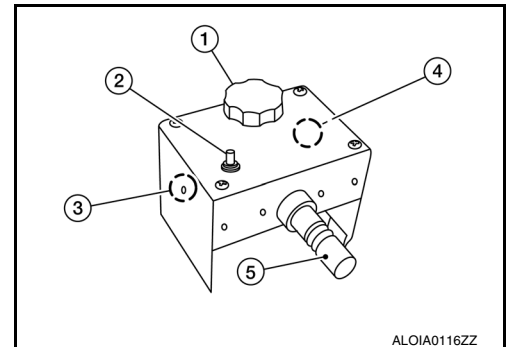

- Stationary target as shown in the illustration.

- Stationary target (1)
- Laser signal reception plate (2)

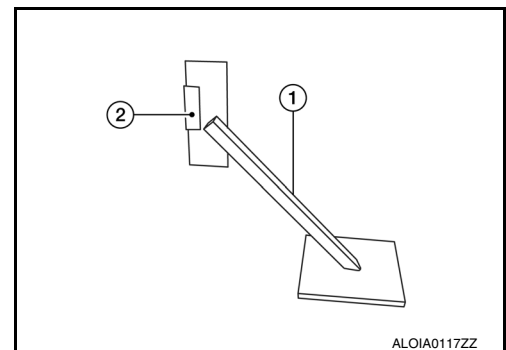

- Distance chain (not shown).

Preparation

INFOID:000000012894573

1. ADVANCE PREPARATION FOR ICC SENSOR ALIGNMENT PROCEDURE

1. Adjust all tire pressure to the specified value.
2. Empty the vehicle. (Remove any luggage from the passenger compartment, luggage room, etc.)
3. Shift the selector lever to "P" position, and release the parking brake.
4. Fully fill the fuel tank, and then check that the coolant and oils are filled up to correct level.
5. Clean off the front of the ICC sensor.

ICC SENSOR ALIGNMENT

[WITH ICC]

< BASIC INSPECTION >

NOTE:

The ICC sensor is located behind the fascia and it is not exposed to the elements. Therefore it should not require any cleaning.

1 : ICC sensor

>> Refer to [BRC-257. "Vehicle Set Up"](#).

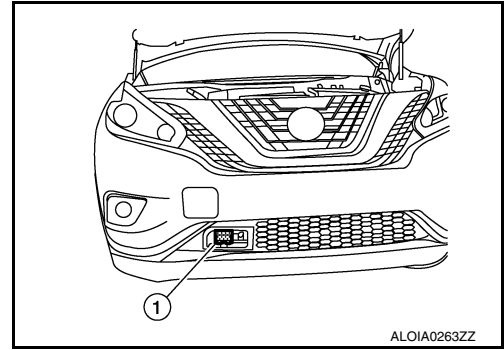

INFOID:000000012894574

Vehicle Set Up

DESCRIPTION

Accurate adjustment of the ICC sensor alignment requires that the ICC target board, wheel adapter, laser assembly, and stationary target be properly positioned.

CAUTION:

If the ICC sensor alignment is adjusted with the ICC target board, wheel adapter, laser assembly, or stationary target in the incorrect position, the ICC system will not function properly or the alignment procedure may not be completed successfully.

1. PREPOSITION TARGET BOARD

NOTE:

- The center of the sensor wave axis (A) is located at the center of the front lens.

B : Up-down direction adjusting screw

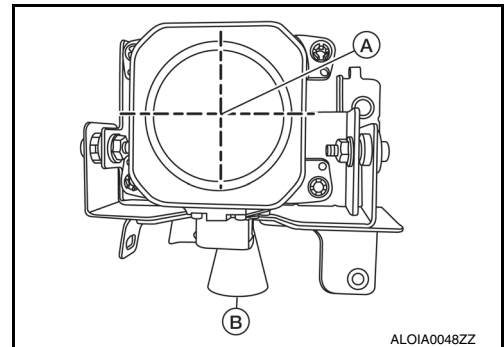

- Initial ICC target board setting must be in the center position.

- Position the ICC target board in front facing the right front side of the vehicle:
 - Using the full length of the supplied chain for distance, place the marked center of the ICC target board (1) 1200 mm (47.2 in.) \pm 625 mm (24.6 in) facing the ICC sensor.
 - Adjust the height of the ICC target board using the adjustable nut (2) to achieve the proper height. The up/down tolerance is \pm 80 mm (3.15 in).
 - Adjust the ICC target board lateral position aligning the marked center of the board horizontally with the center of the ICC sensor front lens. The right/left tolerance is \pm 80 mm (3.15 in).
- Extend the machined arm of the ICC target board exposing the reflective surface (3) to the right front side of the vehicle.

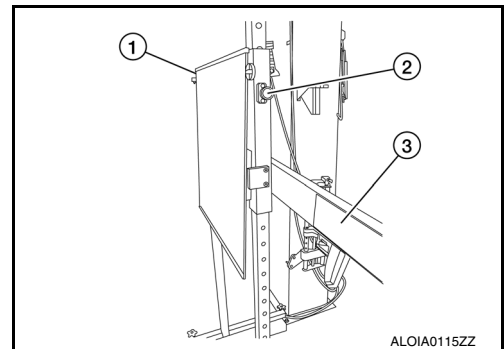

ICC SENSOR ALIGNMENT

[WITH ICC]

< BASIC INSPECTION >

- Place one side of the laser assembly (2) flush against the center of the ICC target board (1) to assist in the positioning.

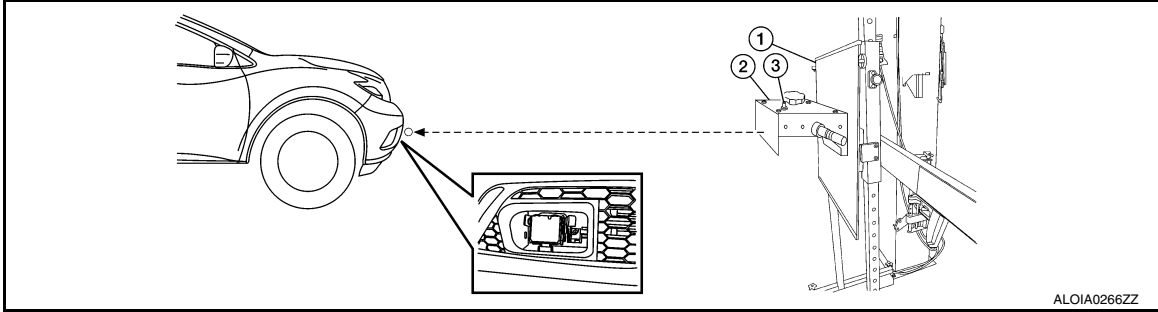

- Turn the laser assembly ON (3) allowing the laser beam to emit through the opening of the laser assembly toward the center of the ICC sensor.
- Move the ICC target board (1) as necessary so that center of ICC target board aligns with center of ICC sensor.
- Turn the laser assembly OFF when done.

Are you using Hunter alignment equipment?

- YES >> Refer to Hunter's equipment instructions for complete vehicle set up and ICC target board setting. Then, refer to [BRC-260. "ICC Sensor Adjustment"](#).
- NO >> GO TO 2.

2. INSTALLING LASER ASSEMBLY

NOTE:

- Insure the steering wheel is positioned in the center straight forward position.
 - Insure all 4 vehicle wheels do not contain any physical damage.
- Install the wheel adapter (1) on the right front wheel.
 - Mount the laser assembly (2) to the wheel adapter (1) as shown in the figure.

NOTE:

When the power switch is turned ON, the front laser signal (A) will be emitted toward the front ICC target board, and the rear laser signal (B) will be emitted toward the rear of the vehicle.

>> GO TO 3.

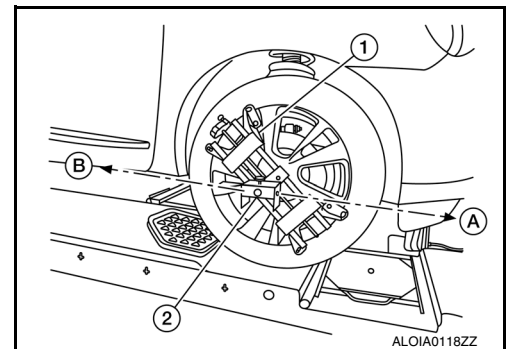

3. SETTING UP STATIONARY TARGET

- Place the stationary target next to the right rear tire as shown in the figure.
- Turn the laser assembly ON allowing the laser beam to be emitted through the front and rear laser assembly openings.
- Measure and record the distance (D_r) between the edge of the right rear wheel and the laser beam (1) on the stationary target (horizontal line).
- Measure and record the height (H_r) between the laser beam (1) on the stationary target and ground level (vertical line).

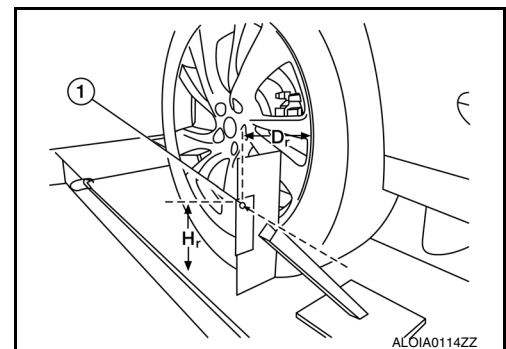

ICC SENSOR ALIGNMENT

[WITH ICC]

< BASIC INSPECTION >

5. Measure and record the distance (D_f) between the edge of the right front wheel and the laser beam signal/opening (1) on the laser assembly (horizontal line).
6. Measure and record the height (H_f) between the laser beam signal/opening (1) on the laser assembly and ground level (vertical line).

NOTE:

- Horizontal adjustment [front distance (D_f) and rear distance (D_r)] is accomplished by slowly turning the steering wheel until the 2 distances are the same.
- Vertical adjustment [front height (H_f) and rear height (H_r)] is accomplished by rotating the laser assembly around its axis until the two heights are the same.
- Directional arrows (A) and (B) are shown to illustrate the direction of the laser assembly beams.

7. Adjust laser beam as necessary until the two distances match and the two heights match.

NOTE:

You will have to verify both horizontal and vertical adjustments anytime one adjustment is made.

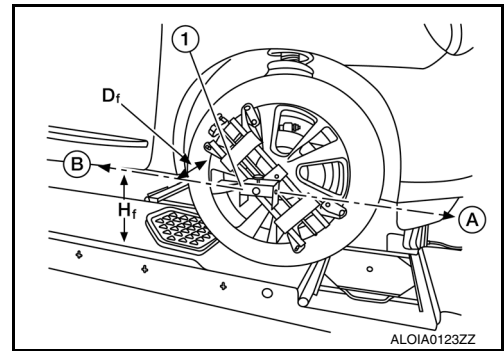

>> Refer to [BRC-259, "Setting The ICC Target Board"](#).

Setting The ICC Target Board

INFOID:000000012894575

DESCRIPTION

Accurate adjustment of the ICC sensor alignment requires that the ICC target board be accurately positioned.

CAUTION:

If the ICC sensor alignment is adjusted with the ICC target board in the incorrect position, the ICC system will not function properly or the alignment procedure may not be completed successfully.

1. ICC TARGET BOARD FINAL SETTING

1. With the ICC target board arm extended, the laser beam (1) emitted by the laser assembly (A) will be reflected back (B) toward the laser assembly.

NOTE:

When adjusted properly, reflected laser beam (B) must align with emitted laser beam (A) and the two laser beams will be seen as one.

2. Rotate the ICC target board to achieve the necessary horizontal adjustment.
3. Adjust the ICC target board leveling screws to achieve the necessary vertical adjustment.

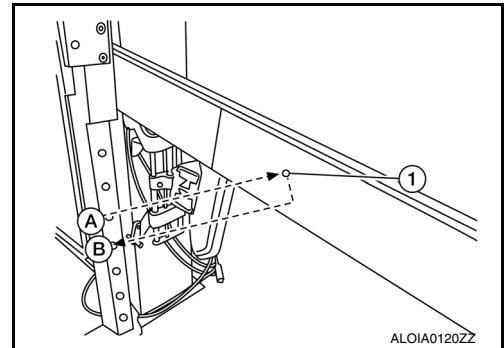

4. The figure shown illustrates the laser beam (A) emitted by the laser assembly (1) and its reflection (B) off of the ICC target board arm.

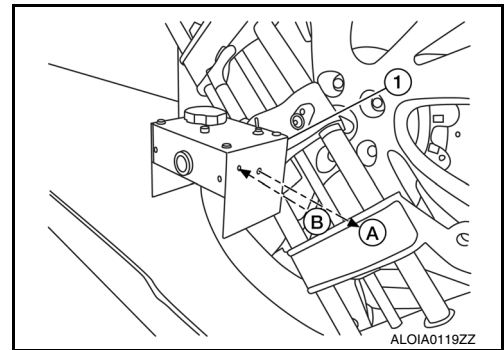

>> GO TO 2.

2. CHECK THE POSITION OF THE ICC TARGET BOARD

ICC SENSOR ALIGNMENT

[WITH ICC]

< BASIC INSPECTION >

Do not place anything other than the ICC target board in the space shown in front of the vehicle (view from top).

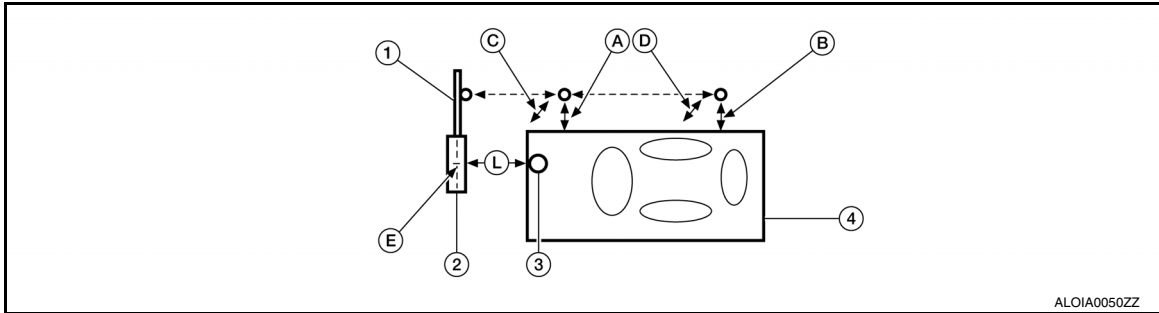

- | | | |
|---|--|---|
| 1. ICC target board arm | 2. ICC target board | 3. ICC sensor |
| 4. Vehicle | A. Distance between front wheel and laser beam (D_f) | B. Distance between rear wheel and laser beam (D_r) |
| C. Height between front laser beam and ground (H_f) | D. Height between rear laser beam and ground (H_r) | E. ICC target board center position (Position 2) |
| L. 1 - 1.5 m (39.3 - 59 in.) | | |

>> Refer to [BRC-260. "ICC Sensor Adjustment"](#).

ICC Sensor Adjustment

INFOID:000000012894576

DESCRIPTION

- Adjust the ICC sensor alignment in a vertical direction with CONSULT as per the following.
- The ICC sensor alignment in the horizontal direction is performed automatically and cannot be adjusted manually.

CAUTION:

- **Never look directly into or block the ICC sensor source (between the front fascia and ICC target board) during the ICC sensor alignment procedure.**
- **Perform all necessary work for ICC sensor alignment procedure until the adjustment completes as shown in the procedure. If the procedure is started but not completed, the ICC system is rendered inoperable.**

1. SET CONSULT TO THE ICC SENSOR ALIGNMENT MODE

1. Place ignition switch in the ON position.
2. Connect CONSULT and select "LASER/RADAR", then "Work support".
3. Select "MILLIWAVE RADAR ADJUST".
4. Select "Start" after the "MILLIWAVE RADAR ADJUST" screen is displayed.

NOTE:

If the adjustment screen does not appear or an error appears within approximately 10 seconds after "RADAR Alignment" is selected, the following causes are possible.

- The ICC target board is not installed in the correct position.
- Adequate space is not secured around the ICC target board.
- The ICC sensor alignment procedure exceeds its proper installation range.
 - Deformation of vehicle body.
 - Deformation of unit.
 - Deformation of bracket.
- The area is not suitable for the adjustment work.
- Right front side of fascia (ICC sensor view) is not clean.
- The ICC system warning lamp illuminates.
- Battery voltage is low.
- The extended arm and mirror are not stationary.

>> GO TO 2.

2. ICC SENSOR ALIGNMENT

ICC SENSOR ALIGNMENT

[WITH ICC]

< BASIC INSPECTION >

1. Once the ICC sensor alignment procedure is started, you will be prompted by the CONSULT for the next instruction.
2. Follow all the instructions exactly as requested by the CONSULT which will include the following:
 - Adjust ICC target board to position 1 (top tilted toward vehicle)
 - Adjust ICC target board to position 2 (vertical position)
 - Adjust ICC target board to position 3 (top tilted away from vehicle)

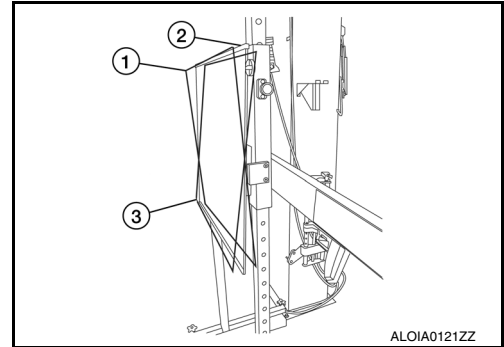

3. You will be prompted with specific instructions to perform physical adjustment to the sensor which may include turning the adjustment screw by a certain number of turns in increments of 0.25 in either direction.

NOTE:

The CONSULT is not live and will not automatically update while turning the tool.

CAUTION:

Be careful not to cover the right front side of the fascia (ICC sensor view) with a hand or any other body part during adjustment.

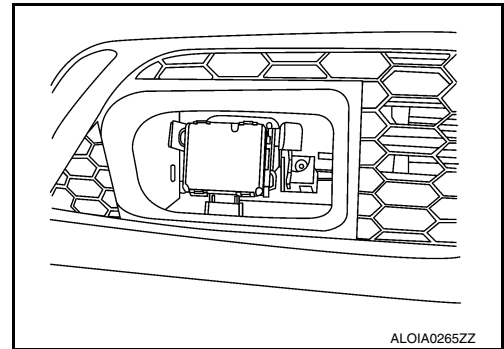

>> GO TO 3.

3. ICC SENSOR ALIGNMENT CONFIRMATION

1. When the "U/D CORRECT" value is executed and the "ADJ VALUE" has been performed, touch "END".
2. When "COMPLETED THE VERTICAL AIMING OF LASER BEAM" display appears, touch "END".
CAUTION:
Always check that the value of "U/D CORRECT" remains accurate (within specification) when the ICC sensor is left alone for at least 2 seconds.
3. Check that "ADJUSTING AUTOMATIC HORIZONTAL LASER BEAM AIMING" is displayed and wait for a short period of time. (The maximum: Approx. 10 seconds).
4. Check that "Normally Completed" is displayed, and select "End" to end "RADAR Alignment".
CAUTION:
Once "RADAR Alignment" is started with CONSULT, always continue the work until the ICC sensor alignment is completed successfully. If the job is stopped midway, the ICC sensor alignment is not completed and the ICC system is rendered inoperative.
5. Confirm proper ICC sensor alignment by following CONSULT steps until it shows "ADJ VALUE" to be 0.00 turn.

>> Alignment End.

ACTION TEST

< BASIC INSPECTION >

[WITH ICC]

ACTION TEST

Description

INFOID:000000012894577

- Perform action test to verify the customer's concern.
- Perform action test and check the system operation after system diagnosis.

Inspection Procedure

INFOID:000000012894578

1.CHECK FEB SYSTEM SETTING

1. Start the engine.
2. Check that the FEB system setting can be enabled/disabled on the vehicle information display.
3. Turn OFF the ignition switch and wait for 30 seconds or more.
4. Check that the previous setting is saved when the engine starts again.

>> GO TO 2.

2.CHECK FEB SYSTEM

1. Enable the setting of the FEB system on the vehicle information display.
2. Check FEB warning lamp is OFF.

>> Inspection End.

C1101, C1102, C1103, C1104 WHEEL SENSOR

< DTC/CIRCUIT DIAGNOSIS >

[WITH ICC]

DTC/CIRCUIT DIAGNOSIS

C1101, C1102, C1103, C1104 WHEEL SENSOR

DTC Description

INFOID:0000000013458360

DTC DETECTION LOGIC

DTC	Display Item (Trouble diagnosis content)	Malfunction detected condition
C1101	RR RH SENSOR-1 (Rear RH wheel sensor-1)	When an open circuit is detected in rear RH wheel sensor circuit.
C1102	RR LH SENSOR-1 (Rear LH wheel sensor-1)	When an open circuit is detected in rear LH wheel sensor circuit.
C1103	FR RH SENSOR-1 (Front RH wheel sensor-1)	When an open circuit is detected in front RH wheel sensor circuit.
C1104	FR LH SENSOR-1 (Front LH wheel sensor-1)	When an open circuit is detected in front LH wheel sensor circuit.

POSSIBLE CAUSE

NOTE:

Confirm if DTC is PAST or CRNT. If DTC is CRNT, proceed with Diagnosis Procedure. If DTC is PAST, clear DTC. Do not replace the ABS actuator and electric unit (control unit) for a PAST DTC.

PAST DTC	CRNT DTC
<ul style="list-style-type: none"> • Harness or connector • ABS actuator and electric unit (control unit) power supply system • Fuse • Fusible link • Battery 	<ul style="list-style-type: none"> • Harness or connector • Wheel sensor • ABS actuator and electric unit (control unit) • ABS actuator and electric unit (control unit) power supply system • Fuse • Fusible link • Battery • Vehicle was not driven after previous repair

DTC CONFIRMATION PROCEDURE

1. PRECONDITIONING

If "DTC CONFIRMATION PROCEDURE" has been previously conducted, always turn the ignition switch OFF and wait at least 10 seconds before conducting the next test.

>> GO TO 2.

2. CHECK DTC DETECTION

CONSULT

1. Start the engine.
2. Drive the vehicle at approx. 50 km/h (31 MPH) or more for approx. 2 minutes.
3. Stop the vehicle.
4. Turn the ignition switch OFF.

NOTE:

Wait at least 10 seconds after turning ignition switch OFF.

5. Start the engine.

NOTE:

Wait at least 10 seconds after start the engine.

6. Repeat step 4 to 5 two or more times.
7. Select "Self Diagnostic Result" mode of "ABS".

Is DTC "C1101", "C1102", "C1103" or "C1104" detected?

YES-1 >> "C1101", "C1102", "C1103" or "C1104" is displayed by "CRNT": Proceed to [BRC-264, "Diagnosis Procedure"](#).

C1101, C1102, C1103, C1104 WHEEL SENSOR

[WITH ICC]

< DTC/CIRCUIT DIAGNOSIS >

YES-2 >> "C1101", "C1102", "C1103" and "C1104" are displayed by "PAST": Inspection End. (Erase the memory of "Self Diagnostic Result" mode of "ABS".)

NO-1 >> To check malfunction symptom before repair: Refer to [GI-42. "Intermittent Incident"](#).

NO-2 >> Confirmation after repair: Inspection End.

Diagnosis Procedure

INFOID:000000013458361

CAUTION:

Never check between wheel sensor harness connector terminals.

1. CHECK WHEEL SENSOR

1. Turn the ignition switch OFF.
2. Check the wheel sensor for damage.

Is the inspection result normal?

YES >> GO TO 3.

NO >> GO TO 2.

2. REPLACE WHEEL SENSOR (1)

CONSULT

1. Replace the wheel sensor.
 - Front: Refer to [BRC-365. "FRONT WHEEL SENSOR : Removal and Installation"](#).
 - Rear: Refer to [BRC-367. "REAR WHEEL SENSOR : Removal and Installation"](#).
2. Erase "Self Diagnostic Result" mode of "ABS".
3. Turn the ignition switch OFF → ON → OFF.

NOTE:

Wait at least 10 seconds after turning ignition switch OFF or ON.

4. Start the engine.
5. Drive the vehicle at approx. 50 km/h (31 MPH) or more for approx. 2 minutes.

NOTE:

Vehicle must be driven after repair or replacement to erase the previous DTCs.

6. Stop the vehicle.
7. Turn the ignition switch OFF.

NOTE:

Wait at least 10 seconds after turning ignition switch OFF.

8. Start the engine.

NOTE:

Wait at least 10 seconds after start the engine.

9. Repeat step 7 to 8 two or more times.
10. Select "Self Diagnostic Result" mode of "ABS".

Is DTC "C1101", "C1102", "C1103" or "C1104" detected?

YES >> GO TO 3.

NO >> Inspection End.

3. CHECK CONNECTOR

1. Turn the ignition switch OFF.
2. Check the ABS actuator and electric unit (control unit) harness connector for disconnection or looseness.
3. Check the wheel sensor harness connector for disconnection or looseness.

Is the inspection result normal?

YES >> GO TO 5.

NO >> Repair / replace harness or connector, securely lock the connector, and GO TO 4.

4. PERFORM SELF DIAGNOSTIC RESULT (1)

CONSULT

1. Erase "Self Diagnostic Result" mode of "ABS".
2. Turn the ignition switch OFF → ON → OFF.

NOTE:

Wait at least 10 seconds after turning ignition switch OFF or ON.

3. Start the engine.
4. Drive the vehicle at approx. 50 km/h (31 MPH) or more for approx. 2 minutes.

NOTE:

C1101, C1102, C1103, C1104 WHEEL SENSOR

[WITH ICC]

< DTC/CIRCUIT DIAGNOSIS >

Vehicle must be driven after repair or replacement to erase the previous DTCs.

5. Stop the vehicle.
6. Turn the ignition switch OFF.

NOTE:

Wait at least 10 seconds after turning ignition switch OFF.

7. Start the engine.

NOTE:

Wait at least 10 seconds after start the engine.

8. Repeat step 6 to 7 two or more times.
9. Select "Self Diagnostic Result" mode of "ABS".

Is DTC "C1101", "C1102", "C1103" or "C1104" detected?

YES >> GO TO 5.

NO >> Inspection End.

5. CHECK ABS ACTUATOR AND ELECTRIC UNIT (CONTROL UNIT) POWER SUPPLY AND GROUND CIRCUIT

Check the ABS actuator and electric unit (control unit) power supply and ground circuit. Refer to [BRC-80](#), "Diagnosis Procedure".

Is the inspection result normal?

YES >> GO TO 6.

NO >> Repair / replace harness, connector, fuse, or fusible link.

6. CHECK TERMINAL

1. Turn the ignition switch OFF.
2. Disconnect ABS actuator and electric unit (control unit) harness connector and then check the ABS actuator and electric unit (control unit) pin terminals for damage or loose connection with harness connector.
3. Disconnect wheel sensor harness connector and check each wheel sensor pin terminals for damage or loose connection with harness connector.

Is the inspection result normal?

YES >> GO TO 8.

NO >> Repair / replace harness, connector, or terminal, and GO TO 7.

7. PERFORM SELF DIAGNOSTIC RESULT (2)

CONSULT

1. Connect ABS actuator and electric unit (control unit) harness connector.
2. Connect wheel sensor harness connector.
3. Erase "Self Diagnostic Result" mode of "ABS".
4. Turn the ignition switch OFF → ON → OFF.
NOTE:
Wait at least 10 seconds after turning ignition switch OFF or ON.
5. Start the engine.
6. Drive the vehicle at approx. 50 km/h (31 MPH) or more for approx. 2 minutes.
NOTE:
Vehicle must be driven after repair or replacement to erase the previous DTCs.
7. Stop the vehicle.
8. Turn the ignition switch OFF.
NOTE:
Wait at least 10 seconds after turning ignition switch OFF.
9. Start the engine.
NOTE:
Wait at least 10 seconds after start the engine.
10. Repeat step 8 to 9 two or more times.
11. Select "Self Diagnostic Result" mode of "ABS".

Is DTC "C1101", "C1102", "C1103" or "C1104" detected?

YES >> GO TO 8.

NO >> Inspection End.

8. CHECK WHEEL SENSOR HARNESS

1. Turn the ignition switch OFF.

C1101, C1102, C1103, C1104 WHEEL SENSOR

[WITH ICC]

< DTC/CIRCUIT DIAGNOSIS >

2. Disconnect ABS actuator and electric unit (control unit) harness connector.
 3. Disconnect wheel sensor harness connector.
 4. Check the continuity between ABS actuator and electric unit (control unit) harness connector and wheel sensor harness connector. (Check the continuity while turning steering wheel left and right, or while moving center harness in wheel housing.)
- Measurement connector and terminal for power supply circuit

ABS actuator and electric unit (control unit)		Wheel sensor		Continuity
Connector	Terminal	Connector	Terminal	
E130	23	E18 (Front LH wheel)	1	Yes
	11	E43 (Front RH wheel)		
	13	C10 (Rear LH wheel)		
	25	C11 (Rear RH wheel)		

- Measurement connector and terminal for signal circuit

ABS actuator and electric unit (control unit)		Wheel sensor		Continuity
Connector	Terminal	Connector	Terminal	
E130	24	E18 (Front LH wheel)	2	Yes
	12	E43 (Front RH wheel)		
	14	C10 (Rear LH wheel)		
	25	C11 (Rear RH wheel)		

Is the inspection result normal?

YES >> GO TO 10.

NO >> Repair / replace harness or connector, and GO TO 9.

9. PERFORM SELF DIAGNOSTIC RESULT (3)

ⓅCONSULT

1. Connect ABS actuator and electric unit (control unit) harness connector.
2. Connect wheel sensor harness connector.
3. Erase "Self Diagnostic Result" mode of "ABS".
4. Turn the ignition switch OFF → ON → OFF.
NOTE:
Wait at least 10 seconds after turning ignition switch OFF or ON.
5. Start the engine.
6. Drive the vehicle at approx. 50 km/h (31 MPH) or more for approx. 2 minutes.
NOTE:
Vehicle must be driven after repair or replacement to erase the previous DTCs.
7. Stop the vehicle.
8. Turn the ignition switch OFF.
NOTE:
Wait at least 10 seconds after turning ignition switch OFF.
9. Start the engine.
NOTE:
Wait at least 10 seconds after start the engine.
10. Repeat step 8 to 9 two or more times.
11. Select "Self Diagnostic Result" mode of "ABS".

Is DTC "C1101", "C1102", "C1103" or "C1104" detected?

YES >> GO TO 10.

NO >> Inspection End.

10. REPLACE WHEEL SENSOR

ⓅCONSULT

1. Replace the wheel sensor.
- Front: Refer to [BRC-365, "FRONT WHEEL SENSOR : Removal and Installation"](#).
- Rear: Refer to [BRC-367, "REAR WHEEL SENSOR : Removal and Installation"](#).

C1101, C1102, C1103, C1104 WHEEL SENSOR

< DTC/CIRCUIT DIAGNOSIS >

[WITH ICC]

2. Erase "Self Diagnostic Result" mode of "ABS".

3. Turn the ignition switch OFF → ON → OFF.

NOTE:

Wait at least 10 seconds after turning ignition switch OFF or ON.

4. Start the engine.

5. Drive the vehicle at approx. 50 km/h (31 MPH) or more for approx. 2 minutes.

NOTE:

Vehicle must be driven after repair or replacement to erase the previous DTCs.

6. Stop the vehicle.

7. Turn the ignition switch OFF.

NOTE:

Wait at least 10 seconds after turning ignition switch OFF.

8. Start the engine.

NOTE:

Wait at least 10 seconds after start the engine.

9. Repeat step 7 to 8 two or more times.

10. Select "Self Diagnostic Result" mode of "ABS".

Is DTC "C1101", "C1102", "C1103" or "C1104" detected?

YES >> Replace the ABS actuator and electric unit (control unit). Refer to [BRC-370, "Removal and Installation"](#).

NO >> Inspection End.

A
B
C
D
E
BRC
G
H
I
J
K
L
M
N
O
P

C1105, C1106, C1107, C1108 WHEEL SENSOR

< DTC/CIRCUIT DIAGNOSIS >

[WITH ICC]

C1105, C1106, C1107, C1108 WHEEL SENSOR

DTC Description

INFOID:000000013458362

DTC DETECTION LOGIC

DTC	Display Item (Trouble diagnosis content)	Malfunction detected condition
C1105	RR RH SENSOR-2 (Rear RH wheel sensor-2)	<ul style="list-style-type: none">• When power supply voltage of rear RH wheel sensor is low.• When distance between rear RH wheel sensor and rear RH wheel sensor rotor is large.• When installation of rear RH wheel sensor or rear RH wheel sensor rotor is not normal.
C1106	RR LH SENSOR-2 (Rear LH wheel sensor-2)	<ul style="list-style-type: none">• When power supply voltage of rear LH wheel sensor is low.• When distance between rear LH wheel sensor and rear LH wheel sensor rotor is large.• When installation of rear LH wheel sensor or rear LH wheel sensor rotor is not normal.
C1107	FR RH SENSOR-2 (Front RH wheel sensor-2)	<ul style="list-style-type: none">• When power supply voltage of front RH wheel sensor is low.• When distance between front RH wheel sensor and front RH wheel sensor rotor is large.• When installation of front RH wheel sensor or front RH wheel sensor rotor is not normal.
C1108	FR LH SENSOR-2 (Front LH wheel sensor-2)	<ul style="list-style-type: none">• When power supply voltage of front LH wheel sensor is low.• When distance between front LH wheel sensor and front LH wheel sensor rotor is large.• When installation of front LH wheel sensor or front LH wheel sensor rotor is not normal.

POSSIBLE CAUSE

NOTE:

Confirm if DTC is PAST or CRNT. If DTC is CRNT, proceed with Diagnosis Procedure. If DTC is PAST, clear DTC. Do not replace the ABS actuator and electric unit (control unit) for a PAST DTC.

PAST DTC	CRNT DTC
<ul style="list-style-type: none">• Harness or connector• Wheel sensor• Sensor rotor• Tire size• ABS actuator and electric unit (control unit) power supply system• Fuse• Fusible link• Battery	<ul style="list-style-type: none">• Harness or connector• Wheel sensor• Sensor rotor• ABS actuator and electric unit (control unit)• Tire size• ABS actuator and electric unit (control unit) power supply system• Fuse• Fusible link• Battery• Vehicle was not driven after previous repair

DTC CONFIRMATION PROCEDURE

1. PRECONDITIONING

If "DTC CONFIRMATION PROCEDURE" has been previously conducted, always turn the ignition switch OFF and wait at least 10 seconds before conducting the next test.

>> GO TO 2.

2. CHECK DTC DETECTION

CONSULT

1. Start the engine.
2. Drive the vehicle at approx. 50 km/h (31 MPH) or more for approx. 2 minutes.
3. Stop the vehicle.
4. Turn the ignition switch OFF.

NOTE:

Wait at least 10 seconds after turning ignition switch OFF.

5. Start the engine.

NOTE:

Wait at least 10 seconds after start the engine.

6. Repeat step 4 to 5 two or more times.
7. Select "Self Diagnostic Result" mode of "ABS".

C1105, C1106, C1107, C1108 WHEEL SENSOR

[WITH ICC]

< DTC/CIRCUIT DIAGNOSIS >

Is DTC "C1105", "C1106", "C1107" or "C1108" detected?

YES-1 >> "C1105", "C1106", "C1107" or "C1108" is displayed by "CRNT": Proceed to [BRC-269, "Diagnosis Procedure"](#).

YES-2 >> "C1105", "C1106", "C1107" and "C1108" are displayed by "PAST": Inspection End. (Erase the memory of "Self Diagnostic Result" mode of "ABS".)

NO-1 >> To check malfunction symptom before repair: Refer to [GI-42, "Intermittent Incident"](#).

NO-2 >> Confirmation after repair: Inspection End.

Diagnosis Procedure

INFOID:000000013458363

CAUTION:

Never check between wheel sensor harness connector terminals.

1. CHECK WHEEL HUB ASSEMBLY

Check that there is no excessive looseness in wheel hub assembly.

- Front: Refer to [FAX-6, "On-vehicle Service"](#).
- Rear: Refer to [RAX-6, "On-vehicle Service"](#).

Is the inspection result normal?

YES >> GO TO 2.

NO >> Repair or replace the wheel hub assembly, and GO TO 2.

- Front: Refer to [FAX-8, "Removal and Installation"](#).
- Rear: Refer to [RAX-8, "Removal and Installation"](#).

2. CHECK ABS ACTUATOR AND ELECTRIC UNIT (CONTROL UNIT) POWER SUPPLY AND GROUND CIRCUIT

Check the ABS actuator and electric unit (control unit) power supply and ground circuit. Refer to [EC-184, "Diagnosis Procedure"](#).

Is the inspection result normal?

YES >> GO TO 3.

NO >> Repair / replace harness, connector, fuse, or fusible link.

3. CHECK TIRE

1. Turn the ignition switch OFF.
2. Check the tire air pressure, wear and size. Refer to [GI-37, "Wheels & Tires"](#).

Is the inspection result normal?

YES >> GO TO 6.

NO >> Adjust air pressure or replace tire, and GO TO 4.

4. CHECK DATA MONITOR (1)

CONSULT

1. Erase "Self Diagnostic Result" mode of "ABS".

2. Turn the ignition switch OFF → ON → OFF.

NOTE:

Wait at least 10 seconds after turning ignition switch OFF or ON.

3. Start the engine.

4. Select "ABS" and "Data Monitor", check "FR LH SENSOR", "FR RH SENSOR", "RR LH SENSOR" and "RR RH SENSOR".

NOTE:

Set the "Data Monitor" recording speed to "10 msec".

5. Read a value (wheel speed) of both normal wheel sensors and error-detecting wheel sensor.

NOTE:

Vehicle must be driven after repair or replacement to erase the previous DTCs.

Note the difference at 50 km/h (31 MPH) between the wheel speed detected by the error detecting wheel sensor and the maximum/minimum wheel speed detected by the normal wheel sensors. Is the difference within 5%, respectively?

YES >> GO TO 5.

NO >> GO TO 6.

5. PERFORM SELF DIAGNOSTIC RESULT (1)

C1105, C1106, C1107, C1108 WHEEL SENSOR

[WITH ICC]

< DTC/CIRCUIT DIAGNOSIS >

ⓅCONSULT

1. Stop the vehicle.
2. Turn the ignition switch OFF.
NOTE:
Wait at least 10 seconds after turning ignition switch OFF.
3. Start the engine.
NOTE:
Wait at least 10 seconds after start the engine.
4. Repeat step 2 to 3 two or more times.
5. Select "Self Diagnostic Result" mode of "ABS".

Is DTC "C1105", "C1106", "C1107" or "C1108" detected?

- YES >> GO TO 6.
NO >> Inspection End.

6.CHECK WHEEL SENSOR

1. Turn the ignition switch OFF.
2. Check the wheel sensor for damage.
3. Remove dust and foreign matter adhered to the sensor rotor with a vacuum dust collector through the wheel sensor mounting hole.

CAUTION:

Install wheel sensor with no backlash and float, and tighten the mounting bolt to the specified torque.

- Front: Refer to [BRC-365, "FRONT WHEEL SENSOR : Removal and Installation"](#).
- Rear: Refer to [BRC-367, "REAR WHEEL SENSOR : Removal and Installation"](#).

Is the inspection result normal?

- YES >> GO TO 9.
NO >> GO TO 7.

7.REPLACE WHEEL SENSOR (1)

ⓅCONSULT

1. Replace the wheel sensor.
 - Front: Refer to [BRC-365, "FRONT WHEEL SENSOR : Removal and Installation"](#).
 - Rear: Refer to [BRC-367, "REAR WHEEL SENSOR : Removal and Installation"](#).
2. Erase "Self Diagnostic Result" mode of "ABS".
3. Turn the ignition switch OFF → ON → OFF.
NOTE:
Wait at least 10 seconds after turning ignition switch OFF or ON.
4. Start the engine.
5. Select "ABS" and "Data Monitor", check "FR LH SENSOR", "FR RH SENSOR", "RR LH SENSOR" and "RR RH SENSOR".
NOTE:
Set the "Data Monitor" recording speed to "10 msec".
6. Read a value (wheel speed) of both normal wheel sensors and error-detecting wheel sensor.

NOTE:

Vehicle must be driven after repair or replacement to erase the previous DTCs.

Note the difference at 50 km/h (31 MPH) between the wheel speed detected by the error detecting wheel sensor and the maximum/minimum wheel speed detected by the normal wheel sensors. Is the difference within 5%, respectively?

- YES >> GO TO 8.
NO >> GO TO 20.

8.PERFORM SELF DIAGNOSTIC RESULT (2)

ⓅCONSULT

1. Stop the vehicle.
2. Turn the ignition switch OFF.
NOTE:
Wait at least 10 seconds after turning ignition switch OFF.
3. Start the engine.
NOTE:

C1105, C1106, C1107, C1108 WHEEL SENSOR

[WITH ICC]

< DTC/CIRCUIT DIAGNOSIS >

Wait at least 10 seconds after start the engine.

4. Repeat step 2 to 3 two or more times.
5. Select "Self Diagnostic Result" mode of "ABS".

Is DTC "C1105", "C1106", "C1107" or "C1108" detected?

YES >> GO TO 20.

NO >> Inspection End.

9. CHECK CONNECTOR

1. Turn the ignition switch OFF.
2. Check the ABS actuator and electric unit (control unit) harness connector for disconnection or looseness.
3. Check the wheel sensor harness connector for disconnection or looseness.

Is the inspection result normal?

YES >> GO TO 12.

NO >> Repair / replace harness or connector, securely lock the connector, and GO TO 10.

10. CHECK DATA MONITOR (2)

CONSULT

1. Erase "Self Diagnostic Result" mode of "ABS".
2. Turn the ignition switch OFF → ON → OFF.

NOTE:

Wait at least 10 seconds after turning ignition switch OFF or ON.

3. Start the engine.
4. Select "ABS" and "Data Monitor", check "FR LH SENSOR", "FR RH SENSOR", "RR LH SENSOR" and "RR RH SENSOR".

NOTE:

Set the "Data Monitor" recording speed to "10 msec".

5. Read a value (wheel speed) of both normal wheel sensors and error-detecting wheel sensor.

NOTE:

Vehicle must be driven after repair or replacement to erase the previous DTCs.

Note the difference at 50 km/h (31 MPH) between the wheel speed detected by the error detecting wheel sensor and the maximum/minimum wheel speed detected by the normal wheel sensors. Is the difference within 5%, respectively?

YES >> GO TO 11.

NO >> GO TO 12.

11. PERFORM SELF DIAGNOSTIC RESULT (3)

CONSULT

1. Stop the vehicle.
2. Turn the ignition switch OFF.

NOTE:

Wait at least 10 seconds after turning ignition switch OFF.

3. Start the engine.

NOTE:

Wait at least 10 seconds after start the engine.

4. Repeat step 2 to 3 two or more times.
5. Select "Self Diagnostic Result" mode of "ABS".

Is DTC "C1105", "C1106", "C1107" or "C1108" detected?

YES >> GO TO 12.

NO >> Inspection End.

12. CHECK TERMINAL

1. Turn the ignition switch OFF.
2. Disconnect ABS actuator and electric unit (control unit) harness connector and then check the ABS actuator and electric unit (control unit) pin terminals for damage or loose connection with harness connector.
3. Disconnect wheel sensor harness connector and check each wheel sensor pin terminals for damage or loose connection with harness connector.

Is the inspection result normal?

YES >> GO TO 15.

C1105, C1106, C1107, C1108 WHEEL SENSOR

[WITH ICC]

< DTC/CIRCUIT DIAGNOSIS >

NO >> Repair / replace harness, connector, or terminal, and GO TO 13.

13.CHECK DATA MONITOR (3)

CONSULT

1. Connect ABS actuator and electric unit (control unit) harness connector.
2. Connect wheel sensor harness connector.
3. Erase "Self Diagnostic Result" mode of "ABS".
4. Turn the ignition switch OFF → ON → OFF.

NOTE:

Wait at least 10 seconds after turning ignition switch OFF or ON.

5. Start the engine.
6. Select "ABS" and "Data Monitor", check "FR LH SENSOR", "FR RH SENSOR", "RR LH SENSOR" and "RR RH SENSOR".

NOTE:

Set the "Data Monitor" recording speed to "10 msec".

7. Read a value (wheel speed) of both normal wheel sensors and error-detecting wheel sensor.

NOTE:

Vehicle must be driven after repair or replacement to erase the previous DTCs.

Note the difference at 50 km/h (31 MPH) between the wheel speed detected by the error detecting wheel sensor and the maximum/minimum wheel speed detected by the normal wheel sensors. Is the difference within 5%, respectively?

YES >> GO TO 14.

NO >> GO TO 15.

14.PERFORM SELF DIAGNOSTIC RESULT (4)

CONSULT

1. Stop the vehicle.
2. Turn the ignition switch OFF.
NOTE:
Wait at least 10 seconds after turning ignition switch OFF.
3. Start the engine.
NOTE:
Wait at least 10 seconds after start the engine.
4. Repeat step 2 to 3 two or more times.
5. Select "Self Diagnostic Result" mode of "ABS".

Is DTC "C1105", "C1106", "C1107" or "C1108" detected?

YES >> GO TO 15.

NO >> Inspection End.

15.CHECK WHEEL SENSOR HARNESS

1. Turn the ignition switch OFF.
2. Disconnect ABS actuator and electric unit (control unit) harness connector.
3. Disconnect wheel sensor harness connector.
4. Check the continuity between ABS actuator and electric unit (control unit) harness connector and the ground.

ABS actuator and electric unit (control unit)		—	Continuity
Connector	Terminal		
E130	23, 24	Ground	No
	11, 12		
	13, 14		
	25, 26		

Is the inspection result normal?

YES >> GO TO 16.

NO >> Repair / replace harness or connector, and GO TO 16.

16.CHECK DATA MONITOR (4)

C1105, C1106, C1107, C1108 WHEEL SENSOR

[WITH ICC]

< DTC/CIRCUIT DIAGNOSIS >

CONSULT

1. Connect ABS actuator and electric unit (control unit) harness connector.
2. Connect wheel sensor harness connector.
3. Erase "Self Diagnostic Result" mode of "ABS".
4. Turn the ignition switch OFF → ON → OFF.

NOTE:

Wait at least 10 seconds after turning ignition switch OFF or ON.

5. Start the engine.
6. Select "ABS" and "Data Monitor", check "FR LH SENSOR", "FR RH SENSOR", "RR LH SENSOR" and "RR RH SENSOR".

NOTE:

Set the "Data Monitor" recording speed to "10 msec".

7. Read a value (wheel speed) of both normal wheel sensors and error-detecting wheel sensor.

NOTE:

Vehicle must be driven after repair or replacement to erase the previous DTCs.

Note the difference at 50 km/h (31 MPH) between the wheel speed detected by the error detecting wheel sensor and the maximum/minimum wheel speed detected by the normal wheel sensors. Is the difference within 5%, respectively?

YES >> GO TO 17.

NO >> GO TO 18.

17.PERFORM SELF DIAGNOSTIC RESULT (5)

CONSULT

1. Stop the vehicle.
2. Turn the ignition switch OFF.

NOTE:

Wait at least 10 seconds after turning ignition switch OFF.

3. Start the engine.

NOTE:

Wait at least 10 seconds after start the engine.

4. Repeat step 2 to 3 two or more times.
5. Select "Self Diagnostic Result" mode of "ABS".

Is DTC "C1105", "C1106", "C1107" or "C1108" detected?

YES >> GO TO 18.

NO >> Inspection End.

18.REPLACE WHEEL SENSOR (2)

CONSULT

1. Replace the wheel sensor.
 - Front: Refer to [BRC-365, "FRONT WHEEL SENSOR : Removal and Installation"](#).
 - Rear: Refer to [BRC-367, "REAR WHEEL SENSOR : Removal and Installation"](#).
2. Erase "Self Diagnostic Result" mode of "ABS".
3. Turn the ignition switch OFF → ON → OFF.

NOTE:

Wait at least 10 seconds after turning ignition switch OFF or ON.

4. Start the engine.
5. Select "ABS" and "Data Monitor", check "FR LH SENSOR", "FR RH SENSOR", "RR LH SENSOR" and "RR RH SENSOR".

NOTE:

Set the "Data Monitor" recording speed to "10 msec".

6. Read a value (wheel speed) of both normal wheel sensors and error-detecting wheel sensor.

NOTE:

Vehicle must be driven after repair or replacement to erase the previous DTCs.

Note the difference at 50 km/h (31 MPH) between the wheel speed detected by the error detecting wheel sensor and the maximum/minimum wheel speed detected by the normal wheel sensors. Is the difference within 5%, respectively?

YES >> GO TO 19.

NO >> GO TO 20.

C1105, C1106, C1107, C1108 WHEEL SENSOR

< DTC/CIRCUIT DIAGNOSIS >

[WITH ICC]

19.PERFORM SELF DIAGNOSTIC RESULT (6)

CONSULT

1. Stop the vehicle.
2. Turn the ignition switch OFF.
NOTE:
Wait at least 10 seconds after turning ignition switch OFF.
3. Start the engine.
NOTE:
Wait at least 10 seconds after start the engine.
4. Repeat step 2 to 3 two or more times.
5. Select "Self Diagnostic Result" mode of "ABS".

Is DTC "C1105", "C1106", "C1107" or "C1108" detected?

- YES >> GO TO 20.
NO >> Inspection End.

20.REPLACE SENSOR ROTOR

CONSULT

1. Replace the sensor rotor.
 - Front: Refer to [BRC-369, "FRONT SENSOR ROTOR : Removal and Installation - Front Sensor Rotor"](#).
 - Rear: Refer to [BRC-369, "REAR SENSOR ROTOR : Removal and Installation - Rear Sensor Rotor"](#).
2. Erase "Self Diagnostic Result" mode of "ABS".
3. Turn the ignition switch OFF → ON → OFF.
NOTE:
Wait at least 10 seconds after turning ignition switch OFF or ON.
4. Start the engine.
5. Drive the vehicle at approx. 50 km/h (31 MPH) or more for approx. 2 minutes.
NOTE:
Vehicle must be driven after repair or replacement to erase the previous DTCs.
6. Stop the vehicle.
7. Turn the ignition switch OFF.
NOTE:
Wait at least 10 seconds after turning ignition switch OFF.
8. Start the engine.
NOTE:
Wait at least 10 seconds after start the engine.
9. Repeat step 7 to 8 two or more times.
10. Select "Self Diagnostic Result" mode of "ABS".

Is DTC "C1105", "C1106", "C1107" or "C1108" detected?

- YES >> Replace the ABS actuator and electric unit (control unit). Refer to [BRC-370, "Removal and Installation"](#).
NO >> Inspection End.

C1109 POWER AND GROUND SYSTEM

< DTC/CIRCUIT DIAGNOSIS >

[WITH ICC]

C1109 POWER AND GROUND SYSTEM

DTC Description

INFOID:000000013458364

DTC DETECTION LOGIC

DTC	Display Item (Trouble diagnosis content)	Malfunction detected condition
C1109	BATTERY VOLTAGE [ABNORMAL] (Battery voltage [abnormal])	When ignition power supply voltage is in following state. <ul style="list-style-type: none">Ignition power supply voltage: $10\text{ V} \geq$ ignition power supply voltage.Ignition power supply voltage: $16\text{ V} \leq$ ignition power supply voltage.

POSSIBLE CAUSE

NOTE:

Confirm if DTC is PAST or CRNT. If DTC is CRNT, proceed with Diagnosis Procedure. If DTC is PAST, clear DTC. Do not replace the ABS actuator and electric unit (control unit) for a PAST DTC.

PAST DTC	CRNT DTC
<ul style="list-style-type: none">Harness or connectorABS actuator and electric unit (control unit) power supply systemFuseFusible linkBatteryCharge system	<ul style="list-style-type: none">Harness or connectorABS actuator and electric unit (control unit)IPDM E/RABS actuator and electric unit (control unit) power supply systemFuseFusible linkBatteryCharge system

DTC CONFIRMATION PROCEDURE

1. PRECONDITIONING

If "DTC CONFIRMATION PROCEDURE" has been previously conducted, always turn the ignition switch OFF and wait at least 10 seconds before conducting the next test.

>> GO TO 2.

2. CHECK DTC DETECTION

CONSULT

- Turn the ignition switch OFF.

NOTE:

Wait at least 10 seconds after turning ignition switch OFF.

- Start the engine.

NOTE:

Wait at least 10 seconds after start the engine.

- Repeat step 1 to 2 two or more times.
- Select "Self Diagnostic Result" for "ABS".

Is DTC "C1109" detected?

YES-1 >> "CRNT" is displayed: Proceed to [BRC-275, "Diagnosis Procedure"](#).

YES-2 >> "PAST" is displayed: Inspection End. (Erase the memory of "Self Diagnostic Result" for "ABS".)

NO-1 >> To check malfunction symptom before repair: Refer to [GI-42, "Intermittent Incident"](#).

NO-2 >> Confirmation after repair: Inspection End.

Diagnosis Procedure

INFOID:000000013458365

1. CHECK CONNECTOR

- Turn the ignition switch OFF.
- Check the ABS actuator and electric unit (control unit) harness connector for disconnection or looseness.

Is the inspection result normal?

YES >> GO TO 3.

C1109 POWER AND GROUND SYSTEM

[WITH ICC]

< DTC/CIRCUIT DIAGNOSIS >

NO >> Repair / replace harness or connector, securely lock the connector, and GO TO 2.

2.PERFORM SELF DIAGNOSTIC RESULT

1. Turn the ignition switch OFF.

NOTE:

Wait at least 10 seconds after turning ignition switch OFF.

2. Start the engine.

NOTE:

Wait at least 10 seconds after start the engine.

3. Repeat step 1 to 2 two or more times.

4. Select "Self Diagnostic Result" mode of "ABS".

Is DTC "C1109" detected?

YES >> GO TO 3.

NO >> Inspection End.

3.CHECK ABS ACTUATOR AND ELECTRIC UNIT (CONTROL UNIT) POWER SUPPLY AND GROUND CIRCUIT

Check the ABS actuator and electric unit (control unit) power supply and ground circuit. Refer to [BRC-275, "Diagnosis Procedure"](#).

Is the inspection result normal?

YES >> GO TO 4.

NO >> Repair / replace harness, connector, fuse, or fusible link.

4.CHECK TERMINAL

1. Check the ABS actuator and electric unit (control unit) pin terminals for damage or loose connection with harness connector.

2. Check the IPDM E/R pin terminals for damage or loose connection with harness connector.

Is the inspection result normal?

YES >> Replace the ABS actuator and electric unit (control unit). Refer to [BRC-370, "Removal and Installation"](#).

NO >> Repair / replace harness, connector, or terminal.

C1110, C1153 ABS ACTUATOR AND ELECTRIC UNIT (CONTROL UNIT)

< DTC/CIRCUIT DIAGNOSIS >

[WITH ICC]

C1110, C1153 ABS ACTUATOR AND ELECTRIC UNIT (CONTROL UNIT)

DTC Description

INFOID:000000013458366

DTC DETECTION LOGIC

DTC	Display Item (Trouble diagnosis content)	Malfunction detected condition
C1110	CONTROLLER FAILURE (Controller failure)	When there is an internal malfunction in the ABS actuator and electric unit (control unit).
C1153	EMERGENCY BRAKE (Emergency brake)	When ABS actuator and electric unit (control unit) is malfunctioning (pressure increase is too much or too little).

POSSIBLE CAUSE

NOTE:

Confirm if DTC is PAST or CRNT. If DTC is CRNT, proceed with Diagnosis Procedure. If DTC is PAST, clear the DTC. Do not replace the ABS actuator and electric unit (control unit) for a PAST DTC.

DTC	PAST DTC	CRNT DTC
C1110	<ul style="list-style-type: none">The vehicle travels near high-voltage electrical power lines.Motor that is built-in the ABS actuator and electric unit (control unit) operates temporarily without a break.Harness or connectorABS actuator and electric unit (control unit) power supply systemFuseFusible linkBattery	<ul style="list-style-type: none">ABS actuator and electric unit (control unit)Harness or connectorABS actuator and electric unit (control unit) power supply systemFuseFusible linkBattery
C1153	<ul style="list-style-type: none">The vehicle travels near high-voltage electrical power lines.ABS operates for a long time (e.g., travel under a tire hydroplaning condition).	ABS actuator and electric unit (control unit)

DTC CONFIRMATION PROCEDURE

1. PRECONDITIONING

If "DTC CONFIRMATION PROCEDURE" has been previously conducted, always turn the ignition switch OFF and wait at least 10 seconds before conducting the next test.

>> GO TO 2.

2. CHECK DTC DETECTION

CONSULT

1. Turn the ignition switch OFF.

NOTE:

Wait at least 10 seconds after turning ignition switch OFF.

2. Start the engine.

NOTE:

Wait at least 10 seconds after starting the engine.

3. Select "Self Diagnostic Result" mode of "ABS".

Is DTC "C1110" or "C1153" detected?

YES-1 >> "C1110" or "C1153" is displayed as "CRNT": Proceed to [BRC-278, "Diagnosis Procedure"](#).

YES-2 >> "C1110" or "C1153" is displayed as "PAST": Inspection End. (Erase "Self Diagnostic Result" mode of "ABS".)

NO-1 >> To check malfunction symptom before repair: Refer to [GI-42, "Intermittent Incident"](#).

NO-2 >> Confirmation after repair: Inspection End.

C1110, C1153 ABS ACTUATOR AND ELECTRIC UNIT (CONTROL UNIT)

< DTC/CIRCUIT DIAGNOSIS >

[WITH ICC]

Diagnosis Procedure

INFOID:000000013458367

1. ADJUST THE NEUTRAL POSITION OF STEERING ANGLE SENSOR

Ⓜ CONSULT

Perform neutral position adjustment of steering angle sensor. Refer to [BRC-247, "Work Procedure"](#).

Is neutral position adjustment of steering angle sensor finished?

YES >> GO TO 2.

NO >> Check the steering angle sensor system. Refer to [BRC-247, "Description"](#).

2. CHECK ABS ACTUATOR AND ELECTRIC UNIT (CONTROL UNIT) POWER SUPPLY AND GROUND CIRCUIT

Check the ABS actuator and electric unit (control unit) power supply and ground circuits. Refer to [BRC-275, "Diagnosis Procedure"](#).

Is the inspection result normal?

YES >> GO TO 3.

NO >> Repair / replace harness, connector, fuse, or fusible link.

3. PERFORM SELF-DIAGNOSIS

Ⓜ CONSULT

Select "Self Diagnostic Result" mode of "ABS".

NOTE:

Replace the ABS actuator and electric unit (control unit) even if other DTCs are displayed along with "C1110" or "C1153" in "Self Diagnostic Result" mode of "ABS".

Is DTC "C1110" or "C1153" detected?

YES >> Replace the ABS actuator and electric unit (control unit). Refer to [BRC-370, "Removal and Installation"](#).

NO >> Inspection End. (Although motor that is built-in the ABS actuator and electric unit (control unit) operates temporarily without a break, this is not a malfunction. Erase "Self Diagnostic Result" mode of "ABS".)

C1111 ABS MOTOR, MOTOR RELAY SYSTEM

< DTC/CIRCUIT DIAGNOSIS >

[WITH ICC]

C1111 ABS MOTOR, MOTOR RELAY SYSTEM

DTC Description

INFOID:000000013458368

DTC DETECTION LOGIC

DTC	Display Item (Trouble diagnosis content)	Malfunction detected condition
C1111	PUMP MOTOR (Pump motor and motor relay)	When a malfunction is detected in motor or motor relay.

POSSIBLE CAUSE

NOTE:

Confirm if DTC is PAST or CRNT. If DTC is CRNT, proceed with Diagnosis Procedure. If DTC is PAST, clear DTC. Do not replace the ABS actuator and electric unit (control unit) for a PAST DTC.

PAST DTC	CRNT DTC
<ul style="list-style-type: none"> • Harness or connector • ABS actuator and electric unit (control unit) power supply system • Fuse • Fusible link • Battery 	<ul style="list-style-type: none"> • Harness or connector • ABS actuator and electric unit (control unit) • ABS actuator and electric unit (control unit) power supply system • Fuse • Fusible link • Battery • Motor/accumulator assembly

DTC CONFIRMATION PROCEDURE

1. PRECONDITIONING

If "DTC CONFIRMATION PROCEDURE" has been previously conducted, always turn the ignition switch OFF and wait at least 10 seconds before conducting the next test.

>> GO TO 2.

2. CHECK DTC DETECTION

CONSULT

1. Turn the ignition switch OFF → ON, and wait 30 seconds.
2. Drive the vehicle at approx. 50 km/h (31 MPH) or more for approx. 2 minutes.
3. Stop the vehicle.
4. Turn the ignition switch OFF.

NOTE:

Wait at least 10 seconds after turning ignition switch OFF.

5. Start the engine.

NOTE:

Wait at least 10 seconds after start the engine.

6. Repeat step 4 to 5 two or more times.
7. Select "Self Diagnostic Result" mode of "ABS".

Is DTC "C1111" detected?

YES-1 >> "CRNT" is displayed: Proceed to [BRC-279, "Diagnosis Procedure"](#).

YES-2 >> "PAST" is displayed: Inspection End. (Erase the memory of "Self Diagnostic Result" mode of "ABS".)

NO-1 >> To check malfunction symptom before repair: Refer to [GI-42, "Intermittent Incident"](#).

NO-2 >> Confirmation after repair: Inspection End.

Diagnosis Procedure

INFOID:000000013458369

1. CHECK CONNECTOR

1. Turn the ignition switch OFF.
2. Check the ABS actuator and electric unit (control unit) harness connector for disconnection or looseness.

C1111 ABS MOTOR, MOTOR RELAY SYSTEM

[WITH ICC]

< DTC/CIRCUIT DIAGNOSIS >

Is the inspection result normal?

YES >> GO TO 3.

NO >> Repair / replace harness or connector, securely lock the connector, and GO TO 2.

2.PERFORM SELF DIAGNOSTIC RESULT

ⓅCONSULT

1. Turn the ignition switch OFF → ON, and wait 30 seconds.

2. Drive the vehicle at approx. 50 km/h (31 MPH) or more for approx. 2 minutes.

NOTE:

Vehicle must be driven after repair or replacement to erase the previous DTCs.

3. Stop the vehicle.

4. Turn the ignition switch OFF.

NOTE:

Wait at least 10 seconds after turning ignition switch OFF.

5. Start the engine.

NOTE:

Wait at least 10 seconds after start the engine.

6. Repeat step 4 to 5 two or more times.

7. Select "Self Diagnostic Result" mode of "ABS".

Is DTC "C1111" detected?

YES >> GO TO 3.

NO >> Inspection End.

3.CHECK ABS ACTUATOR AND ELECTRIC UNIT (CONTROL UNIT) POWER SUPPLY AND GROUND CIRCUIT

Check the ABS actuator and electric unit (control unit) power supply and ground circuit. Refer to [EC-184, "Diagnosis Procedure"](#).

Is the inspection result normal?

YES >> GO TO 5.

NO >> Repair / replace harness, connector, or fuse, and GO TO 4.

4.ERASE SELF DIAGNOSTIC RESULT (1)

ⓅCONSULT

1. Drive the vehicle at approx. 50 km/h (31 MPH) or more for approx. 2 minutes.

NOTE:

Vehicle must be driven after repair or replacement to erase the previous DTCs.

2. Stop the vehicle.

3. Erase "Self Diagnostic Result" mode of "ABS".

4. Turn the ignition switch OFF → ON → OFF.

NOTE:

Wait at least 10 seconds after turning ignition switch OFF or ON.

>> Inspection End.

5.CHECK TERMINAL

1. Turn the ignition switch OFF.

2. Check the ABS actuator and electric unit (control unit) pin terminals for damage or loose connection with harness connector.

Is the inspection result normal?

YES >> Replace the ABS actuator and electric unit (control unit). Refer to [BRC-369, "REAR SENSOR ROTOR : Removal and Installation - Rear Sensor Rotor"](#).

NO >> Repair / replace harness or connector, and GO TO 6.

6.ERASE SELF-DIAGNOSIS RESULT (2)

ⓅCONSULT

1. Drive the vehicle at approx. 50 km/h (31 MPH) or more for approx. 2 minutes.

NOTE:

Vehicle must be driven after repair or replacement to erase the previous DTCs.

C1111 ABS MOTOR, MOTOR RELAY SYSTEM

< DTC/CIRCUIT DIAGNOSIS >

[WITH ICC]

2. Stop the vehicle.
3. Erase "Self Diagnostic Result" mode of "ABS".
4. Turn the ignition switch OFF → ON → OFF.

NOTE:

Wait at least 10 seconds after turning ignition switch OFF or ON.

>> Inspection End.

A

B

C

D

E

BRC

G

H

I

J

K

L

M

N

O

P

C1113, C1145, C1146 YAW RATE/SIDE/DECEL G SENSOR

< DTC/CIRCUIT DIAGNOSIS >

[WITH ICC]

C1113, C1145, C1146 YAW RATE/SIDE/DECEL G SENSOR

DTC Description

INFOID:000000013458370

DTC DETECTION LOGIC

DTC	Display item (Trouble diagnosis content)	Malfunction detected condition
C1113	G-SENSOR (Decel G sensor circuit)	When a malfunction is detected in decel G signal.
C1145	YAW RATE SENSOR (Yaw rate sensor circuit)	<ul style="list-style-type: none"> When a malfunction is detected in yaw rate signal. When a signal line of yaw rate/side/decel G sensor is open or shorted. When power supply voltage of yaw rate/side/decel G sensor is in following state. <ul style="list-style-type: none"> - Yaw rate/side/decel G sensor power supply voltage: $4.8\text{ V} \geq$ yaw rate/side/decel G sensor power supply voltage - Yaw rate/side/decel G sensor power supply voltage: $5.2\text{ V} \leq$ yaw rate/side/decel G sensor power supply voltage
C1146	SIDE G-SEN CIRCUIT (Side G sensor circuit)	When a malfunction is detected in side G signal.

POSSIBLE CAUSE

NOTE:

Confirm if DTC is PAST or CRNT. If DTC is CRNT, proceed with Diagnosis Procedure. If DTC is PAST, clear DTC. Do not replace the ABS actuator and electric unit (control unit) for a PAST DTC.

DTC	PAST DTC	CRNT DTC
C1113	<ul style="list-style-type: none"> Harness or connector ABS actuator and electric unit (control unit) power supply system Fuse Fusible link Battery Change in vehicle posture (e.g. different tire sizes on front and rear, overload) 	<ul style="list-style-type: none"> Harness or connector Yaw rate/side/decel G sensor ABS actuator and electric unit (control unit) ABS actuator and electric unit (control unit) power supply system Fuse Fusible link Battery Change in vehicle posture (e.g. different tire sizes on front and rear, overload)
C1145	<ul style="list-style-type: none"> Harness or connector ABS actuator and electric unit (control unit) power supply system Fuse Fusible link Battery 	<ul style="list-style-type: none"> Harness or connector Yaw rate/side/decel G sensor ABS actuator and electric unit (control unit) ABS actuator and electric unit (control unit) power supply system Fuse Fusible link Battery
C1146		

DTC CONFIRMATION PROCEDURE

1. PRECONDITIONING

If "DTC CONFIRMATION PROCEDURE" has been previously conducted, always turn the ignition switch OFF and wait at least 10 seconds before conducting the next test.

>> GO TO 2.

2. CHECK DTC DETECTION

CONSULT

1. Turn the ignition switch OFF.

NOTE:

Wait at least 10 seconds after turning ignition switch OFF.

2. Start the engine.

NOTE:

Wait at least 10 seconds after start the engine.

C1113, C1145, C1146 YAW RATE/SIDE/DECEL G SENSOR

[WITH ICC]

< DTC/CIRCUIT DIAGNOSIS >

3. Repeat step 1 to 2 two or more times.
4. Select "Self Diagnostic" mode of "ABS".

Is DTC "C1113", "C1145" or "C1146" detected?

YES-1 >> "C1113", "C1145", or "C1146" is displayed by "CRNT": Proceed to [BRC-283, "Diagnosis Procedure"](#).

YES-2 >> "C1113", "C1145", and "C1146" are displayed by "PAST": Inspection End (Erase the memory of "Self Diagnostic" mode of "ABS".)

NO-1 >> To check malfunction symptom before repair: Refer to [GI-42, "Intermittent Incident"](#).

NO-2 >> Confirmation after repair: Inspection End.

Diagnosis Procedure

INFOID:000000013458371

1. CHECK ABS ACTUATOR AND ELECTRIC UNIT (CONTROL UNIT) POWER SUPPLY AND GROUND CIRCUIT

Check the ABS actuator and electric unit (control unit) power supply and ground circuit. Refer to [BRC-80, "Diagnosis Procedure"](#).

Is the inspection result normal?

YES >> GO TO 2.

NO >> Repair / replace harness, connector, fuse, or fusible link.

2. PERFORM SELF DIAGNOSTIC RESULT

ⓂCONSULT

1. Turn the ignition switch OFF.

NOTE:

Wait at least 10 seconds after turning ignition switch OFF.

2. Start the engine.

NOTE:

Wait at least 10 seconds after start the engine.

3. Repeat step 1 to 2 two or more times.
4. Select "Self Diagnostic Result" mode of "ABS".

Is DTC "C1113", "C1145" or "C1146" detected?

YES >> Replace the ABS actuator and electric unit (control unit). Refer to [BRC-370, "Removal and Installation"](#).

NO >> Inspection End.

C1115 WHEEL SENSOR

[WITH ICC]

< DTC/CIRCUIT DIAGNOSIS >

C1115 WHEEL SENSOR

DTC Description

INFOID:000000013458372

DTC DETECTION LOGIC

DTC	Display Item (Trouble diagnosis content)	Malfunction detected condition
C1115	ABS SENSOR [ABNORMAL SIGNAL] (Wheel sensor [abnormal signal])	When difference in wheel speed between any wheel and others is detected the vehicle is driven, because of installation of other tires than specified.

POSSIBLE CAUSE

NOTE:

Confirm if DTC is PAST or CRNT. If DTC is CRNT, proceed with Diagnosis Procedure. If DTC is PAST, clear DTC. Do not replace the ABS actuator and electric unit (control unit) for a PAST DTC.

PAST DTC	CRNT DTC
<ul style="list-style-type: none">• Harness or connector• Wheel sensor• Sensor rotor• ABS actuator and electric unit (control unit) power supply system• Fuse• Fusible link• Battery	<ul style="list-style-type: none">• Harness or connector• Wheel sensor• Sensor rotor• ABS actuator and electric unit (control unit)• ABS actuator and electric unit (control unit) power supply system• Fuse• Fusible link• Battery• Tire size

DTC CONFIRMATION PROCEDURE

1. PRECONDITIONING

If "DTC CONFIRMATION PROCEDURE" has been previously conducted, always turn the ignition switch OFF and wait at least 10 seconds before conducting the next test.

>> GO TO 2.

2. CHECK DTC DETECTION

Ⓟ CONSULT

1. Start the engine.
2. Drive the vehicle at approx. 50 km/h (19 MPH) or more for approx. 2 minutes.
3. Stop the vehicle.
4. Turn the ignition switch OFF.

NOTE:

Wait at least 10 seconds after turning ignition switch OFF.

5. Start the engine.

NOTE:

Wait at least 10 seconds after start the engine.

6. Repeat step 4 to 5 two or more times.
7. Select "Self Diagnostic Result" mode of "ABS".

Is DTC "C1115" detected?

- YES-1 >> "CRNT" is displayed: Proceed to [BRC-284, "Diagnosis Procedure"](#).
- YES-2 >> "PAST" is displayed: Inspection End. (Erase the memory of self-diagnosis results.)
- NO-1 >> To check malfunction symptom before repair: Refer to [GI-42, "Intermittent Incident"](#).
- NO-2 >> Confirmation after repair: Inspection End.

Diagnosis Procedure

INFOID:000000013458373

CAUTION:

C1115 WHEEL SENSOR

[WITH ICC]

< DTC/CIRCUIT DIAGNOSIS >

Never check between wheel sensor harness connector terminals.

1. CHECK TIRE

Check the tire air pressure, wear and size. Refer to [GI-37, "Wheels & Tires"](#).

Is the inspection result normal?

YES >> GO TO 4.

NO >> Adjust air pressure or replace tire and GO TO 2.

2. CHECK DATA MONITOR (1)

ⓂCONSULT

1. Erase "Self Diagnostic Result" mode of "ABS".

2. Turn the ignition switch OFF → ON → OFF.

NOTE:

Wait at least 10 seconds after turning ignition switch OFF or ON.

3. Start the engine.

4. Select "ABS" and "Data Monitor", check "FR LH SENSOR", "FR RH SENSOR", "RR LH SENSOR" and "RR RH SENSOR".

NOTE:

Set the "Data Monitor" recording speed to "10 msec".

5. Read a value (wheel speed) of both normal wheel sensors and error-detecting wheel sensor.

NOTE:

Vehicle must be driven after repair or replacement to erase the previous DTCs.

Note the difference at 50 km/h (31 MPH) between the wheel speed detected by the error detecting wheel sensor and the maximum/minimum wheel speed detected by the normal wheel sensors. Is the difference within 5%, respectively?

YES >> GO TO 3.

NO >> GO TO 4.

3. PERFORM SELF DIAGNOSTIC RESULT (1)

ⓂCONSULT

1. Stop the vehicle.

2. Turn the ignition switch OFF.

NOTE:

Wait at least 10 seconds after turning ignition switch OFF.

3. Start the engine.

NOTE:

Wait at least 10 seconds after start the engine.

4. Repeat step 2 to 3 two or more times.

5. Select "Self Diagnostic Result" mode of "ABS".

Is DTC "C1115" detected?

YES >> GO TO 4.

NO >> INSPECTION END

4. CHECK ABS ACTUATOR AND ELECTRIC UNIT (CONTROL UNIT) POWER SUPPLY AND GROUND CIRCUIT

Check the ABS actuator and electric unit (control unit) power supply and ground circuit. Refer to [BRC-275, "Diagnosis Procedure"](#).

Is the inspection result normal?

YES >> GO TO 5.

NO >> Repair / replace harness, connector, fuse, or fusible link.

5. CHECK WHEEL SENSOR

1. Turn the ignition switch OFF.

2. Check the wheel sensor for damage.

3. Remove dust and foreign matter adhered to the sensor rotor with a vacuum dust collector through the wheel sensor mounting hole.

CAUTION:

Install wheel sensor with no backlash and float, and tighten the mounting bolt to the specified torque.

A
B
C
D
E
BRC
G
H
I
J
K
L
M
N
O
P

C1115 WHEEL SENSOR

[WITH ICC]

< DTC/CIRCUIT DIAGNOSIS >

- Front: Refer to [BRC-365, "FRONT WHEEL SENSOR : Removal and Installation"](#).
- Rear: Refer to [BRC-367, "REAR WHEEL SENSOR : Removal and Installation"](#).

Is the inspection result normal?

- YES >> GO TO 8.
- NO >> GO TO 6.

6. REPLACE WHEEL SENSOR (1)

ⓅCONSULT

1. Replace the wheel sensor.
 - Front: Refer to [BRC-365, "FRONT WHEEL SENSOR : Removal and Installation"](#).
 - Rear: Refer to [BRC-367, "REAR WHEEL SENSOR : Removal and Installation"](#).
2. Erase "Self Diagnostic Result" mode of "ABS".
3. Turn the ignition switch OFF → ON → OFF.
NOTE:
Wait at least 10 seconds after turning ignition switch OFF or ON.
4. Start the engine.
5. Select "ABS" and "Data Monitor", check "FR LH SENSOR", "FR RH SENSOR", "RR LH SENSOR" and "RR RH SENSOR".
NOTE:
Set the "Data Monitor" recording speed to "10 msec".
6. Read a value (wheel speed) of both normal wheel sensors and error-detecting wheel sensor.
NOTE:
Vehicle must be driven after repair or replacement to erase the previous DTCs.

Note the difference at 50 km/h (31 MPH) between the wheel speed detected by the error detecting wheel sensor and the maximum/minimum wheel speed detected by the normal wheel sensors. Is the difference within 5%, respectively?

- YES >> GO TO 7.
- NO >> GO TO 19.

7. PERFORM SELF DIAGNOSTIC RESULT (2)

ⓅCONSULT

1. Stop the vehicle.
2. Turn the ignition switch OFF.
NOTE:
Wait at least 10 seconds after turning ignition switch OFF.
3. Start the engine.
NOTE:
Wait at least 10 seconds after start the engine.
4. Repeat step 2 to 3 two or more times.
5. Select "Self Diagnostic Result" mode of "ABS".

Is DTC "C1115" detected?

- YES >> GO TO 8.
- NO >> Inspection End.

8. CHECK CONNECTOR

1. Turn the ignition switch OFF.
2. Check the ABS actuator and electric unit (control unit) harness connector for disconnection or looseness.
3. Check the wheel sensor harness connector for disconnection or looseness.

Is the inspection result normal?

- YES >> GO TO 11.
- NO >> Repair / replace harness or connector, securely lock the connector, and GO TO 9.

9. CHECK DATA MONITOR (2)

ⓅCONSULT

1. Erase "Self Diagnostic Result" mode of "ABS".
2. Turn the ignition switch OFF → ON → OFF.
NOTE:
Wait at least 10 seconds after turning ignition switch OFF or ON.
3. Start the engine.

C1115 WHEEL SENSOR

[WITH ICC]

< DTC/CIRCUIT DIAGNOSIS >

4. Select "ABS" and "Data Monitor", check "FR LH SENSOR", "FR RH SENSOR", "RR LH SENSOR" and "RR RH SENSOR".

NOTE:

Set the "Data Monitor" recording speed to "10 msec".

5. Read a value (wheel speed) of both normal wheel sensors and error-detecting wheel sensor.

NOTE:

Vehicle must be driven after repair or replacement to erase the previous DTCs.

Note the difference at 50 km/h (31 MPH) between the wheel speed detected by the error detecting wheel sensor and the maximum/minimum wheel speed detected by the normal wheel sensors. Is the difference within 5%, respectively?

YES >> GO TO 10.

NO >> GO TO 11.

10.PERFORM SELF DIAGNOSTIC RESULT (3)

CONSULT

1. Stop the vehicle.
2. Turn the ignition switch OFF.

NOTE:

Wait at least 10 seconds after turning ignition switch OFF.

3. Start the engine.

NOTE:

Wait at least 10 seconds after start the engine.

4. Repeat step 2 to 3 two or more times.
5. Select "Self Diagnostic Result" mode of "ABS".

Is DTC "C1115" detected?

YES >> GO TO 11.

NO >> Inspection End.

11.CHECK TERMINAL

1. Turn the ignition switch OFF.
2. Disconnect ABS actuator and electric unit (control unit) harness connector and then check the ABS actuator and electric unit (control unit) pin terminals for damage or loose connection with harness connector.
3. Disconnect wheel sensor harness connector and check each wheel sensor pin terminals for damage or loose connection with harness connector.

Is the inspection result normal?

YES >> GO TO 14.

NO >> Repair / replace harness, connector, or terminal, and GO TO 12.

12.CHECK DATA MONITOR (3)

CONSULT

1. Connect ABS actuator and electric unit (control unit) harness connector.
2. Connect wheel sensor harness connector.
3. Erase "Self Diagnostic Result" mode of "ABS".
4. Turn the ignition switch OFF → ON → OFF.

NOTE:

Wait at least 10 seconds after turning ignition switch OFF or ON.

5. Start the engine.
6. Select "ABS" and "Data Monitor", check "FR LH SENSOR", "FR RH SENSOR", "RR LH SENSOR" and "RR RH SENSOR".

NOTE:

Set the "Data Monitor" recording speed to "10 msec".

7. Read a value (wheel speed) of both normal wheel sensors and error-detecting wheel sensor.

NOTE:

Vehicle must be driven after repair or replacement to erase the previous DTCs.

Note the difference at 50 km/h (31 MPH) between the wheel speed detected by the error detecting wheel sensor and the maximum/minimum wheel speed detected by the normal wheel sensors. Is the difference within 5%, respectively?

YES >> GO TO 13.

NO >> GO TO 14.

A

B

C

D

E

BRC

G

H

I

J

K

L

M

N

O

P

C1115 WHEEL SENSOR

< DTC/CIRCUIT DIAGNOSIS >

[WITH ICC]

13. PERFORM SELF DIAGNOSTIC RESULT (4)

CONSULT

1. Stop the vehicle.
2. Turn the ignition switch OFF.
NOTE:
Wait at least 10 seconds after turning ignition switch OFF.
3. Start the engine.
NOTE:
Wait at least 10 seconds after start the engine.
4. Repeat step 2 to 3 two or more times.
5. Select "Self Diagnostic Result" mode of "ABS".

Is DTC "C1115" detected?

- YES >> GO TO 14.
NO >> Inspection End.

14. CHECK WHEEL SENSOR HARNESS

1. Turn the ignition switch OFF.
 2. Disconnect ABS actuator and electric unit (control unit) harness connector.
 3. Disconnect wheel sensor harness connector.
 4. Check the continuity between ABS actuator and electric unit (control unit) harness connector and wheel sensor harness connector. (Check continuity while turning steering wheel left and right, or while moving center harness in wheel housing.)
- Measurement connector and terminal for power supply circuit

ABS actuator and electric unit (control unit)		Wheel sensor		Continuity
Connector	Terminal	Connector	Terminal	
E130	23	E18 (Front LH wheel)	1	Yes
	11	E43 (Front RH wheel)		
	13	C10 (Rear LH wheel)		
	25	C11 (Rear RH wheel)		

- Measurement connector and terminal for signal circuit

ABS actuator and electric unit (control unit)		Wheel sensor		Continuity
Connector	Terminal	Connector	Terminal	
E130	24	E18 (Front LH wheel)	2	Yes
	12	E43 (Front RH wheel)		
	14	C10 (Rear LH wheel)		
	26	C11 (Rear RH wheel)		

5. Check the continuity between ABS actuator and electric unit (control unit) harness connector and the ground.

ABS actuator and electric unit (control unit)		—	Continuity
Connector	Terminal		
E130	23, 24	Ground	No
	11, 12		
	13, 14		
	25, 26		

Is the inspection result normal?

- YES >> GO TO 15.
NO >> Repair / replace harness or connector, and GO TO 15.

C1115 WHEEL SENSOR

< DTC/CIRCUIT DIAGNOSIS >

[WITH ICC]

15. CHECK DATA MONITOR (4)

CONSULT

1. Connect ABS actuator and electric unit (control unit) harness connector.
2. Connect wheel sensor harness connector.
3. Erase "Self Diagnostic Result" mode of "ABS".
4. Turn the ignition switch OFF → ON → OFF.

NOTE:

Wait at least 10 seconds after turning ignition switch OFF or ON.

5. Start the engine.
6. Select "ABS" and "Data Monitor", check "FR LH SENSOR", "FR RH SENSOR", "RR LH SENSOR" and "RR RH SENSOR".

NOTE:

Set the "Data Monitor" recording speed to "10 msec".

7. Read a value (wheel speed) of both normal wheel sensors and error-detecting wheel sensor.

NOTE:

Vehicle must be driven after repair or replacement to erase the previous DTCs.

Note the difference at 50 km/h (31 MPH) between the wheel speed detected by the error detecting wheel sensor and the maximum/minimum wheel speed detected by the normal wheel sensors. Is the difference within 5%, respectively?

YES >> GO TO 16.

NO >> GO TO 17.

16. PERFORM SELF DIAGNOSTIC RESULT (5)

CONSULT

1. Stop the vehicle.
 2. Turn the ignition switch OFF.
- NOTE:**
Wait at least 10 seconds after turning ignition switch OFF.

3. Start the engine.

NOTE:

Wait at least 10 seconds after start the engine.

4. Repeat step 2 to 3 two or more times.
5. Select "Self Diagnostic Result" mode of "ABS".

Is DTC "C1115" detected?

YES >> GO TO 17.

NO >> Inspection End.

17. REPLACE WHEEL SENSOR (2)

CONSULT

1. Replace the wheel sensor.
 - Front: Refer to [BRC-365, "FRONT WHEEL SENSOR : Removal and Installation"](#).
 - Rear: Refer to [BRC-367, "REAR WHEEL SENSOR : Removal and Installation"](#).
2. Erase "Self Diagnostic Result" mode of "ABS".
3. Turn the ignition switch OFF → ON → OFF.

NOTE:

Wait at least 10 seconds after turning ignition switch OFF or ON.

4. Start the engine.
5. Select "ABS" and "Data Monitor", check "FR LH SENSOR", "FR RH SENSOR", "RR LH SENSOR" and "RR RH SENSOR".

NOTE:

Set the "Data Monitor" recording speed to "10 msec".

6. Read a value (wheel speed) of both normal wheel sensors and error-detecting wheel sensor.

NOTE:

Vehicle must be driven after repair or replacement to erase the previous DTCs.

Note the difference at 50 km/h (31 MPH) between the wheel speed detected by the error detecting wheel sensor and the maximum/minimum wheel speed detected by the normal wheel sensors. Is the difference within 5%, respectively?

YES >> GO TO 18.

C1115 WHEEL SENSOR

[WITH ICC]

< DTC/CIRCUIT DIAGNOSIS >

NO >> GO TO 19.

18.PERFORM SELF DIAGNOSTIC RESULT(6)

CONSULT

1. Stop the vehicle.
2. Turn the ignition switch OFF.
NOTE:
Wait at least 10 seconds after turning ignition switch OFF.
3. Start the engine.
NOTE:
Wait at least 10 seconds after start the engine.
4. Repeat step 2 to 3 two or more times.
5. Select "Self Diagnostic Result" mode of "ABS".

Is DTC "C1115" detected?

YES >> GO TO 19.

NO >> Inspection End.

19.REPLACE SENSOR ROTOR

CONSULT

1. Replace the sensor rotor.
 - Front: Refer to [BRC-369, "FRONT SENSOR ROTOR : Removal and Installation - Front Sensor Rotor"](#).
 - Rear: Refer to [BRC-369, "REAR SENSOR ROTOR : Removal and Installation - Rear Sensor Rotor"](#).
2. Erase "Self Diagnostic Result" mode of "ABS".
3. Turn the ignition switch OFF → ON → OFF.
NOTE:
Wait at least 10 seconds after turning ignition switch OFF or ON.
4. Start the engine.
5. Drive the vehicle at approx. 50 km/h (31 MPH) or more for approx. 2 minutes.
NOTE:
Vehicle must be driven after repair or replacement to erase the previous DTCs.
6. Stop the vehicle.
7. Turn the ignition switch OFF.
NOTE:
Wait at least 10 seconds after turning ignition switch OFF.
8. Start the engine.
NOTE:
Wait at least 10 seconds after start the engine.
9. Repeat step 7 to 8 two or more times.
10. Select "Self Diagnostic Result" mode of "ABS".

Is DTC "C1115" detected?

YES >> Replace the ABS actuator and electric unit (control unit). Refer to [BRC-370, "Removal and Installation"](#).

NO >> Inspection End.

C1116 STOP LAMP SWITCH

[WITH ICC]

< DTC/CIRCUIT DIAGNOSIS >

C1116 STOP LAMP SWITCH

DTC Description

INFOID:000000013458914

DTC DETECTION LOGIC

DTC	Display Item (Trouble diagnosis content)	Malfunction detected condition
C1116	STOP LAMP SW (Stop lamp switch)	When stop lamp switch signal is not input when brake pedal operates.

POSSIBLE CAUSE

NOTE:

Confirm if DTC is PAST or CRNT. If DTC is CRNT, proceed with Diagnosis Procedure. If DTC is PAST, clear the DTC. Do not replace the ABS actuator and electric unit (control unit) for a PAST DTC.

PAST DTC	CRNT DTC
<ul style="list-style-type: none"> • Harness or connector • Stop lamp switch signal circuit 	<ul style="list-style-type: none"> • Harness or connector • Stop lamp switch • ABS actuator and electric unit (control unit) • Resistor (models with ICC system) • ABS actuator and electric unit (control unit) power supply system • Fuse • Fusible link • Battery

DTC CONFIRMATION PROCEDURE

1. PRECONDITIONING

If "DTC CONFIRMATION PROCEDURE" has been previously conducted, always turn the ignition switch OFF and wait at least 10 seconds before conducting the next test.

>> GO TO 2.

2. CHECK DTC DETECTION

CONSULT

1. Turn the ignition switch OFF, and wait 10 seconds or more.
2. Start the engine.

NOTE:

Stop the vehicle.

3. Wait 1 minute or more.

NOTE:

Never depress brake pedal.

4. Depress brake pedal by 100 mm (3.94 in) or more, and maintain at that position for a minimum of 1 minute or more.

5. Release brake pedal, and wait 1 minute or more.

6. Repeat step 4 to 5 ten or more times.

7. Turn the ignition switch OFF.

NOTE:

Wait at least 10 seconds after turning ignition switch OFF.

8. Start the engine.

NOTE:

Wait at least 10 seconds after starting the engine.

9. Select "Self Diagnostic Result" mode of "ABS".

Is DTC "C1116" detected?

YES-1 >> "C1116" is displayed as "CRNT": Proceed to [BRC-292, "Diagnosis Procedure"](#).

YES-2 >> "C1116" is displayed as "PAST": Inspection End (Erase "Self Diagnostic Result" mode of "ABS").

NO-1 >> To check malfunction symptom before repair: Refer to [GI-44, "Circuit Inspection"](#).

NO-2 >> Confirmation after repair: Inspection End.

C1116 STOP LAMP SWITCH

[WITH ICC]

< DTC/CIRCUIT DIAGNOSIS >

INFOID:000000013458915

Diagnosis Procedure

NOTE:

DTC "C1116" may be detected when the brake pedal and the accelerator pedal are simultaneously depressed for 1 minute or more while driving the vehicle. This is not a malfunction.

1. INTERVIEW FROM THE CUSTOMER

Check if the brake pedal and the accelerator pedal are simultaneously depressed for 1 minute or more while driving the vehicle.

Is there such a history?

- YES >> GO TO 2.
- NO >> GO TO 3.

2. PERFORM SELF-DIAGNOSIS

ⓐ CONSULT

1. Erase "Self Diagnostic Result" mode of "ABS"
2. Turn the ignition switch OFF → ON → OFF.
NOTE:
Wait at least 10 seconds after turning ignition switch OFF or ON.
3. Start the engine.
NOTE:
Stop the vehicle.
4. Depress the brake pedal several times.
5. Turn the ignition switch OFF.
NOTE:
Wait at least 10 seconds after turning ignition switch OFF.
6. Start the engine.
NOTE:
Wait at least 10 seconds after starting the engine.
7. Select "Self Diagnostic Result" of "ABS".

Is DTC "C1116" detected?

- YES >> GO TO 3.
- NO >> Inspection End.

3. STOP LAMP FOR ILLUMINATION

Depress brake pedal and check that stop lamp turns ON.

Does stop lamp turn ON?

- YES >> GO TO 5.
- NO >> Check the stop lamp system. Refer to [BRC-292, "Diagnosis Procedure"](#). GO TO 4.

4. CHECK DATA MONITOR (1)

ⓐ CONSULT

1. Erase "Self Diagnostic Result" mode of "ABS"
2. Turn the ignition switch OFF → ON → OFF.
NOTE:
Wait at least 10 seconds after turning ignition switch OFF or ON.
3. Start the engine.
NOTE:
Stop the vehicle.
4. Select "Data Monitor" mode of "ABS", check "STOP LAMP SW". Check that data monitor displays "On" or "Off" when brake pedal is depressed or released. Refer to [BRC-222, "Reference Value"](#).
5. Select "Data Monitor" mode of "ABS", check "PRESS SENSOR". Check that data monitor displays "5 bar" or less when brake pedal is depressed. Refer to [BRC-222, "Reference Value"](#).

Is the inspection result normal?

- YES >> Inspection End.
- NO >> GO TO 5.

5. CHECK CONNECTOR

1. Turn the ignition switch OFF.

C1116 STOP LAMP SWITCH

[WITH ICC]

< DTC/CIRCUIT DIAGNOSIS >

2. Check the ABS actuator and electric unit (control unit) harness connector for disconnection or looseness.
3. Check the stop lamp switch harness connector for disconnection or looseness.

Is the inspection result normal?

- YES >> GO TO 6.
NO >> Repair / replace harness or connector, and GO TO 6.

6. CHECK ABS ACTUATOR AND ELECTRIC UNIT (CONTROL UNIT) POWER SUPPLY AND GROUND CIRCUIT

Check the ABS actuator and electric unit (control unit) power supply and ground circuits. Refer to [BRC-275, "Diagnosis Procedure"](#).

Is the inspection result normal?

- YES >> GO TO 7.
NO >> Repair / replace harness, connector, fuse, or fusible link.

7. CHECK STOP LAMP SWITCH CLEARANCE

1. Turn the ignition switch OFF.
2. Check the stop lamp switch clearance. Refer to [BR-7, "Inspection"](#).

Is the inspection result normal?

- YES >> GO TO 9.
NO >> Adjust stop lamp switch clearance. Refer to [BR-13, "Adjustment"](#). GO TO 8.

8. CHECK DATA MONITOR (2)

ⓂCONSULT

1. Erase "Self Diagnostic Result" mode of "ABS"
2. Turn the ignition switch OFF → ON → OFF.
NOTE:
Wait at least 10 seconds after turning ignition switch OFF or ON.
3. Start the engine.
NOTE:
Stop the vehicle.
4. Select "DATA MONITOR" of "ABS", check "STOP LAMP SW". Check that data monitor displays "On" or "Off" when brake pedal is depressed or released. Refer to [BRC-222, "Reference Value"](#).
5. Select "DATA MONITOR" of "ABS", check "PRESS SENSOR". Check that data monitor displays "5 bar" or less when brake pedal is depressed. Refer to [BRC-222, "Reference Value"](#).

Is the inspection result normal?

- YES >> Inspection End.
NO >> GO TO 9.

9. CHECK STOP LAMP SWITCH

Check the stop lamp switch. Refer to [BRC-296, "Component Inspection"](#).

Is the inspection result normal?

- YES >> GO TO 10.
NO >> Replace the stop lamp switch. Refer to [BR-20, "Exploded View"](#). GO TO 10.

10. CHECK DATA MONITOR (3)

ⓂCONSULT

1. Erase "Self Diagnostic Result" mode of "ABS"
2. Turn the ignition switch OFF → ON → OFF.
NOTE:
Wait at least 10 seconds after turning ignition switch OFF or ON.
3. Start the engine.
NOTE:
Start the vehicle.
4. Select "DATA MONITOR" of "ABS", check "STOP LAMP SW". Check that data monitor displays "On" or "Off" when brake pedal is depressed or released. Refer to [BRC-222, "Reference Value"](#).
5. Select "DATA MONITOR" of "ABS", check "PRESS SENSOR". Check that data monitor displays "5 bar" or less when brake pedal is depressed. Refer to [BRC-222, "Reference Value"](#).

Is the inspection result normal?

C1116 STOP LAMP SWITCH

[WITH ICC]

< DTC/CIRCUIT DIAGNOSIS >

- YES >> Inspection End.
- NO >> GO TO 11.

11. CHECK CONNECTOR AND TERMINAL

1. Turn the ignition switch OFF.
2. Disconnect ABS actuator and electric unit (control unit) harness connector.
3. Check the ABS actuator and electric unit (control unit) harness connector for disconnection or looseness.
4. Check the ABS actuator and electric unit (control unit) pin terminals for damage or loose connection with harness connector.
5. Disconnect stop lamp switch harness connector.
6. Check the stop lamp switch harness connector for disconnection or looseness.
7. Check the stop lamp switch pin terminals for damage or loose connection with harness connector.
8. Disconnect resistor harness connector.
9. Check the resistor harness connector for disconnection or looseness.
10. Check the resistor pin terminals for damage or loose connection with harness connector.

Is the inspection result normal?

- YES >> GO TO 13.
- NO >> Repair / replace harness, connector, or terminal, and GO TO 12.

12. CHECK DATA MONITOR (4)

CONSULT

1. Connect ABS actuator and electric unit (control unit) harness connector.
2. Connect stop lamp switch harness connector.
3. Connect resistor harness connector.
4. Erase "Self Diagnostic Result" mode of "ABS"
5. Turn the ignition switch OFF → ON → OFF.
NOTE:
Wait at least 10 seconds after turning ignition switch OFF or ON.
6. Start the engine.
NOTE:
Stop the vehicle.
7. Select "DATA MONITOR" of "ABS", check "STOP LAMP SW". Check that data monitor displays "On" or "Off" when brake pedal is depressed or released. Refer to [BRC-222, "Reference Value"](#).
8. Select "DATA MONITOR" of "ABS", check "PRESS SENSOR". Check that data monitor displays "5 bar" or less when brake pedal is depressed. Refer to [BRC-222, "Reference Value"](#).

Is the inspection result normal?

- YES >> Inspection End.
- NO >> GO TO 13.

13. CHECK STOP LAMP SWITCH CIRCUIT (1)

1. Turn the ignition switch OFF.
2. Disconnect ABS actuator and electric unit (control unit) harness connector.
3. Check the voltage between ABS actuator and electric unit (control unit) harness connector and ground.

ABS actuator and electric unit (control unit)		—	Condition	Voltage
Connector	Terminal			
E130	7	Ground	Brake pedal depressed	Battery voltage (Approx.)
			Brake pedal not depressed	Approx. 0 V

4. Turn the ignition switch ON.
5. Check the voltage between ABS actuator and electric unit (control unit) harness connector and ground.

ABS actuator and electric unit (control unit)		—	Condition	Voltage
Connector	Terminal			
E130	7	Ground	Brake pedal depressed	Battery voltage (Approx.)
			Brake pedal not depressed	Approx. 0 V

C1116 STOP LAMP SWITCH

[WITH ICC]

< DTC/CIRCUIT DIAGNOSIS >

Is the inspection result normal?

- YES >> Replace the ABS actuator and electric unit (control unit). Refer to [BRC-370, "Removal and Installation"](#).
 NO >> Repair / replace harness or connector, and GO TO 14.

14.CHECK STOP LAMP SWITCH CIRCUIT (2)

- Turn the ignition switch OFF.
- Disconnect stop lamp switch harness connector.
- Disconnect resistor harness connector.
- Check the continuity between ABS actuator and electric unit (control unit) harness connector and stop lamp switch harness connector.

ABS actuator and electric unit (control unit)		Stop lamp switch		Continuity
Connector	Terminal	Connector	Terminal	
E130	7	E38	4	Yes

- Check the continuity between ABS actuator and electric unit (control unit) harness connector and resistor harness connector.

ABS actuator and electric unit (control unit)		Resistor		Continuity
Connector	Terminal	Connector	Terminal	
E130	7	E56	1	Yes

- Check the continuity between ABS actuator and electric unit (control unit) harness connector and the ground.

ABS actuator and electric unit (control unit)		—	Continuity
Connector	Terminal		
E130	7	Ground	No

- Check the continuity between resistor and the ground.

Resistor		—	Continuity
Connector	Terminal		
E56	1	Ground	No
	2		Yes

Is the inspection result normal?

- YES >> Replace the ABS actuator and electric unit (control unit). Refer to [BRC-370, "Removal and Installation"](#).
 NO >> Repair / replace harness or connector, and GO TO 15.

15.CHECK DATA MONITOR (5)

CONSULT

- Connect ABS actuator and electric unit (control unit) harness connector.
- Connect stop lamp switch harness connector.
- Connect resistor harness connector.
- Erase "Self Diagnostic Result" mode of "ABS"
- Turn the ignition switch OFF → ON → OFF.
NOTE:
 Wait at least 10 seconds after turning ignition switch OFF or ON.
- Start the engine.
NOTE:
 Stop the vehicle.
- Select "DATA MONITOR" of "ABS", check "STOP LAMP SW". Check that data monitor displays "On" or "Off" when brake pedal is depressed or released. Refer to [BRC-222, "Reference Value"](#).
- Select "DATA MONITOR" of "ABS", check "PRESS SENSOR". Check that data monitor displays "5 bar" or less when brake pedal is depressed. Refer to [BRC-222, "Reference Value"](#).

C1116 STOP LAMP SWITCH

[WITH ICC]

< DTC/CIRCUIT DIAGNOSIS >

Is the inspection result normal?

- YES >> Inspection End.
NO >> Replace the ABS actuator and electric unit (control unit). Refer to [BRC-370, "Removal and Installation"](#).

Component Inspection

INFOID:000000013458916

1. CHECK STOP LAMP SWITCH

1. Turn the ignition switch OFF.
2. Disconnect stop lamp switch harness connector.
3. Check the continuity when stop lamp switch is operated.

Stop lamp switch Terminal	Condition	Continuity
2 – 1	When stop lamp switch is released (When brake pedal is depressed)	Yes
	When stop lamp switch is pressed (When brake pedal is released)	No

Is the inspection result normal?

- YES >> Inspection End.
NO >> Replace the stop lamp switch. Refer to [BR-20, "Exploded View"](#).

C1120, C1122, C1124, C1126 ABS IN VALVE SYSTEM

< DTC/CIRCUIT DIAGNOSIS >

[WITH ICC]

C1120, C1122, C1124, C1126 ABS IN VALVE SYSTEM

DTC Description

INFOID:000000013458377

DTC DETECTION LOGIC

DTC	Display Item (Trouble diagnosis content)	Malfunction detected condition
C1120	FR LH IN ABS SOL (Front LH ABS IN solenoid valve)	When a malfunction is detected in front LH ABS IN valve.
C1122	FR RH IN ABS SOL (Front RH ABS IN solenoid valve)	When a malfunction is detected in front RH ABS IN valve.
C1124	RR LH IN ABS SOL (Rear LH ABS IN solenoid valve)	When a malfunction is detected in rear LH ABS IN valve.
C1126	RR RH IN ABS SOL (Rear RH ABS IN solenoid valve)	When a malfunction is detected in rear RH ABS IN valve.

POSSIBLE CAUSE

NOTE:

Confirm if DTC is PAST or CRNT. If DTC is CRNT, proceed with Diagnosis Procedure. If DTC is PAST, clear DTC. Do not replace the ABS actuator and electric unit (control unit) for a PAST DTC.

PAST DTC	CRNT DTC
<ul style="list-style-type: none"> • Harness or connector • ABS actuator and electric unit (control unit) power supply system • Fuse • Fusible link • Battery 	<ul style="list-style-type: none"> • Harness or connector • ABS actuator and electric unit (control unit) • ABS actuator and electric unit (control unit) power supply system • Fuse • Fusible link • Battery

DTC CONFIRMATION PROCEDURE

1. PRECONDITIONING

If "DTC CONFIRMATION PROCEDURE" has been previously conducted, always turn the ignition switch OFF and wait at least 10 seconds before conducting the next test.

>> GO TO 2.

2. CHECK DTC DETECTION

CONSULT

1. Turn the ignition switch OFF.

NOTE:

Wait at least 10 seconds after turning ignition switch OFF.

2. Start the engine.

NOTE:

Wait at least 10 seconds after start the engine.

3. Repeat step 1 to 2 two or more times.
4. Select "Self Diagnostic Result" mode of "ABS".

Is DTC "C1120", "C1122", "C1124" or "C1126" detected?

YES-1 >> "C1120", "C1122", "C1124" or "C1126" is displayed by "CRNT": Proceed to [BRC-298, "Diagnosis Procedure"](#).

YES-2 >> "C1120", "C1122", "C1124" or "C1126" is displayed by "PAST": Inspection End (Erase the memory of "Self Diagnostic Result" mode of "ABS".)

NO-1 >> To check malfunction symptom before repair: Refer to [GI-42, "Intermittent Incident"](#).

NO-2 >> Confirmation after repair: Inspection End.

C1120, C1122, C1124, C1126 ABS IN VALVE SYSTEM

< DTC/CIRCUIT DIAGNOSIS >

[WITH ICC]

INFOID:000000013458378

Diagnosis Procedure

1. CHECK CONNECTOR

1. Turn the ignition switch OFF.
2. Check the ABS actuator and electric unit (control unit) harness connector for disconnection or looseness.

Is the inspection result normal?

- YES >> GO TO 3.
NO >> Repair / replace harness or connector, securely lock the connector, and GO TO 2.

2. PERFORM SELF DIAGNOSTIC RESULT

CONSULT

1. Turn the ignition switch OFF.
NOTE:
Wait at least 10 seconds after turning ignition switch OFF.
2. Start the engine.
NOTE:
Wait at least 10 seconds after start the engine.
3. Repeat step 1 to 2 two or more times.
4. Select "Self Diagnostic Result" mode of "ABS".

Is DTC "C1120", "C1122", "C1124" or "C1126" detected?

- YES >> GO TO 3.
NO >> Inspection End.

3. CHECK ABS ACTUATOR AND ELECTRIC UNIT (CONTROL UNIT) POWER SUPPLY AND GROUND CIRCUIT

Check the ABS actuator and electric unit (control unit) power supply and ground circuit. Refer to [BRC-275, "Diagnosis Procedure"](#).

Is the inspection result normal?

- YES >> GO TO 4.
NO >> Repair / replace harness, connector, fuse, or fusible link.

4. CHECK TERMINAL

Check the ABS actuator and electric unit (control unit) pin terminals for damage or loose connection with harness connector.

Is the inspection result normal?

- YES >> Replace the ABS actuator and electric unit (control unit). Refer to [BRC-370, "Removal and Installation"](#).
NO >> Repair / replace harness, connector, or terminal.

C1121, C1123, C1125, C1127 ABS OUT VALVE SYSTEM

< DTC/CIRCUIT DIAGNOSIS >

[WITH ICC]

C1121, C1123, C1125, C1127 ABS OUT VALVE SYSTEM

DTC Description

INFOID:000000013458379

DTC DETECTION LOGIC

DTC	Display Item (Trouble diagnosis content)	Malfunction detected condition
C1121	FR LH OUT ABS SOL (Front LH ABS OUT solenoid valve)	When a malfunction is detected in front LH ABS OUT valve.
C1123	FR RH OUT ABS SOL (Front RH ABS OUT solenoid valve)	When a malfunction is detected in front RH ABS OUT valve.
C1125	RR LH OUT ABS SOL (Rear LH ABS OUT solenoid valve)	When a malfunction is detected in rear LH ABS OUT valve.
C1127	RR RH OUT ABS SOL (Rear RH ABS OUT solenoid valve)	When a malfunction is detected in rear RH ABS OUT valve.

POSSIBLE CAUSE

NOTE:

Confirm if DTC is PAST or CRNT. If DTC is CRNT, proceed with Diagnosis Procedure. If DTC is PAST, clear DTC. Do not replace the ABS actuator and electric unit (control unit) for a PAST DTC.

PAST DTC	CRNT DTC
<ul style="list-style-type: none">• Harness or connector• ABS actuator and electric unit (control unit) power supply system• Fuse• Fusible link• Battery	<ul style="list-style-type: none">• Harness or connector• ABS actuator and electric unit (control unit)• ABS actuator and electric unit (control unit) power supply system• Fuse• Fusible link• Battery

DTC CONFIRMATION PROCEDURE

1. PRECONDITIONING

If "DTC CONFIRMATION PROCEDURE" has been previously conducted, always turn the ignition switch OFF and wait at least 10 seconds before conducting the next test.

>> GO TO 2.

2. CHECK DTC DETECTION

CONSULT

1. Turn the ignition switch OFF.

NOTE:

Wait at least 10 seconds after turning ignition switch OFF.

2. Start the engine.

NOTE:

Wait at least 10 seconds after start the engine.

3. Repeat step 1 to 2 two or more times.
4. Select "Self Diagnostic Result" mode of "ABS".

Is DTC "C1121", "C1123", "C1125" or "C1127" detected?

YES-1 >> "C1121", "C1123", "C1125" or "C1127" is displayed by "CRNT": Proceed to [BRC-300, "Diagnosis Procedure"](#).

YES-2 >> "C1121", "C1123", "C1125" and "C1127" are displayed by "PAST": Inspection End (Erase the memory of "Self Diagnostic Result" mode of "ABS".)

NO-1 >> To check malfunction symptom before repair: Refer to [GI-42, "Intermittent Incident"](#).

NO-2 >> Confirmation after repair: Inspection End.

C1121, C1123, C1125, C1127 ABS OUT VALVE SYSTEM

< DTC/CIRCUIT DIAGNOSIS >

[WITH ICC]

Diagnosis Procedure

INFOID:000000013458380

1. CHECK CONNECTOR

1. Turn the ignition switch OFF.
2. Check the ABS actuator and electric unit (control unit) harness connector for disconnection or looseness.

Is the inspection result normal?

YES >> GO TO 3.

NO >> Repair / replace harness or connector, securely lock the connector, and GO TO 2.

2. SELECT SELF DIAGNOSTIC RESULT

1. Turn the ignition switch OFF.
NOTE:
Wait at least 10 seconds after turning ignition switch OFF.

2. Start the engine.

NOTE:

Wait at least 10 seconds after start the engine.

3. Repeat step 1 to 2 two or more times.
4. Select "Self Diagnostic Result" mode of "ABS".

Is DTC "C1121", "C1123", "C1125" or "C1127" detected?

YES >> GO TO 3.

NO >> Inspection End.

3. CHECK ABS ACTUATOR AND ELECTRIC UNIT (CONTROL UNIT) POWER SUPPLY AND GROUND CIRCUIT

Check the ABS actuator and electric unit (control unit) power supply and ground circuit. Refer to [EC-184, "Diagnosis Procedure"](#).

Is the inspection result normal?

YES >> GO TO 4.

NO >> Repair / replace harness, connector, fuse, or fusible link.

4. CHECK TERMINAL

Check the ABS actuator and electric unit (control unit) pin terminals for damage or loose connection with harness connector.

Is the inspection result normal?

YES >> Replace the ABS actuator and electric unit (control unit). Refer to [BRC-370, "Removal and Installation"](#).

NO >> Repair / replace harness, connector, or terminal.

C1130 ENGINE SIGNAL

< DTC/CIRCUIT DIAGNOSIS >

[WITH ICC]

C1130 ENGINE SIGNAL

DTC Description

INFOID:000000013458381

DTC DETECTION LOGIC

DTC	Display Item (Trouble diagnosis content)	Malfunction detected condition
C1130	ENGINE SIGNAL 1 (Engine system signal)	When a malfunction is detected in ECM system.

POSSIBLE CAUSE

NOTE:

Confirm if DTC is PAST or CRNT. If DTC is CRNT, proceed with Diagnosis Procedure. If DTC is PAST, clear DTC. Do not replace the ABS actuator and electric unit (control unit) for a PAST DTC.

PAST DTC	CRNT DTC
<ul style="list-style-type: none">• Harness or connector• ABS actuator and electric unit (control unit) power supply system• Fuse• Fusible link• Battery• CAN communication line	<ul style="list-style-type: none">• Harness or connector• ECM• ABS actuator and electric unit (control unit)• ABS actuator and electric unit (control unit) power supply system• Fuse• Fusible link• Battery• CAN communication line

DTC CONFIRMATION PROCEDURE

1. PRECONDITIONING

If "DTC CONFIRMATION PROCEDURE" has been previously conducted, always turn the ignition switch OFF and wait at least 10 seconds before conducting the next test.

>> GO TO 2.

2. CHECK DTC DETECTION

CONSULT

1. Turn the ignition switch OFF.

NOTE:

Wait at least 10 seconds after turning ignition switch OFF.

2. Start the engine.

NOTE:

Wait at least 10 seconds after start the engine.

3. Repeat step 1 to 2 two or more times.
4. Select "Self Diagnostic Result" mode of "ABS".

Is DTC "C1130" detected?

YES-1 >> "CRNT" is displayed: Proceed to [BRC-301, "Diagnosis Procedure"](#).

YES-2 >> "PAST" is displayed: Inspection End (Erase the memory of "Self Diagnostic Result" mode of "ABS".)

NO-1 >> To check malfunction symptom before repair: Refer to [GI-42, "Intermittent Incident"](#).

NO-2 >> Confirmation after repair: Inspection End.

Diagnosis Procedure

INFOID:000000013458382

1. CHECK ENGINE SYSTEM

CONSULT

Select "Self Diagnostic Result" mode of "ENGINE".

Is DTC detected?

YES >> Check the DTC. Refer to [EC-105, "DTC Index"](#) (VQ35DE).

C1130 ENGINE SIGNAL

[WITH ICC]

< DTC/CIRCUIT DIAGNOSIS >

NO >> GO TO 2.

2.CHECK ABS ACTUATOR AND ELECTRIC UNIT (CONTROL UNIT) POWER SUPPLY AND GROUND CIRCUIT

Check the ABS actuator and electric unit (control unit) power supply and ground circuit. Refer to [EC-184, "Diagnosis Procedure"](#).

Is the inspection result normal?

YES >> GO TO 3.

NO >> Repair / replace harness, connector, fuse, or fusible link.

3.CHECK CONNECTOR AND TERMINAL

1. Turn the ignition switch OFF.
2. Disconnect ECM harness connector.
3. Disconnect ABS actuator and electric unit (control unit) harness connector.
4. Check the connector for disconnection or looseness.
5. Check the pin terminals for damage or loose connection with harness connector.

Is the inspection result normal?

YES >> GO TO 4.

NO >> Repair / replace harness, connector, or terminal, securely lock the connector, and GO TO 4.

4.CHECK ABS ACTUATOR AND ELECTRIC UNIT (CONTROL UNIT)

ⓅCONSULT

1. Connect ECM harness connector.
2. Connect ABS actuator and electric unit (control unit) harness connector.
3. Erase "Self Diagnostic Result" mode of "ABS".
4. Turn the ignition switch OFF.

NOTE:

Wait at least 10 seconds after turning ignition switch OFF.

5. Start the engine.

NOTE:

Wait at least 10 seconds after start the engine.

6. Repeat step 4 to 5 two or more times.
7. Select "Self Diagnostic Result" mode of "ABS".

Is DTC "C1130" or "U1000" detected?

YES ("C1130")>>GO TO 1.

YES ("U1000")>>Refer to [LAN-21, "Trouble Diagnosis Flow Chart"](#).

NO >> Inspection End.

C1140 ACTUATOR RELAY SYSTEM

< DTC/CIRCUIT DIAGNOSIS >

[WITH ICC]

C1140 ACTUATOR RELAY SYSTEM

DTC Description

INFOID:000000013458383

DTC DETECTION LOGIC

DTC	Display Item (Trouble diagnosis content)	Malfunction detected condition
C1140	ACTUATOR RLY (Actuator relay)	When a malfunction is detected in actuator relay.

POSSIBLE CAUSE

NOTE:

Confirm if DTC is PAST or CRNT. If DTC is CRNT, proceed with Diagnosis Procedure. If DTC is PAST, clear DTC. Do not replace the ABS actuator and electric unit (control unit) for a PAST DTC.

PAST DTC	CRNT DTC
<ul style="list-style-type: none">• Harness or connector• ABS actuator and electric unit (control unit) power supply system• Fuse• Fusible link• Battery	<ul style="list-style-type: none">• Harness or connector• ABS actuator and electric unit (control unit)• ABS actuator and electric unit (control unit) power supply system• Fuse• Fusible link• Battery

DTC CONFIRMATION PROCEDURE

1. PRECONDITIONING

If "DTC CONFIRMATION PROCEDURE" has been previously conducted, always turn the ignition switch OFF and wait at least 10 seconds before conducting the next test.

>> GO TO 2.

2. CHECK DTC DETECTION

CONSULT

1. Turn the ignition switch OFF.

NOTE:

Wait at least 10 seconds after turning ignition switch OFF.

2. Start the engine.

NOTE:

Wait at least 10 seconds after start the engine.

3. Repeat step 1 to 2 two or more times.
4. Select "Self Diagnostic Result" mode of "ABS".

Is DTC "C1140" detected?

YES-1 >> "CRNT" is displayed: Proceed to [BRC-303. "Diagnosis Procedure"](#).

YES-2 >> "PAST" is displayed: Inspection End (Erase the memory of "Self Diagnostic Result" mode of "ABS".)

NO-1 >> To check malfunction symptom before repair: Refer to [GI-42. "Intermittent Incident"](#).

NO-2 >> Confirmation after repair: Inspection End.

Diagnosis Procedure

INFOID:000000013458384

1. CHECK CONNECTOR

1. Turn the ignition switch OFF.
2. Check the ABS actuator and electric unit (control unit) harness connector for disconnection or looseness.

Is the inspection result normal?

YES >> GO TO 3.

NO >> Repair / replace harness or connector, securely lock the connector, and GO TO 2.

C1140 ACTUATOR RELAY SYSTEM

[WITH ICC]

< DTC/CIRCUIT DIAGNOSIS >

2. PERFORM SELF DIAGNOSTIC RESULT

CONSULT

1. Turn the ignition switch OFF.
NOTE:
Wait at least 10 seconds after turning ignition switch OFF.
2. Start the engine.
NOTE:
Wait at least 10 seconds after start the engine.
3. Repeat step 1 to 2 two or more times.
4. Select "Self Diagnostic Result" mode of "ABS".

Is DTC "C1140" detected?

- YES >> GO TO 3.
NO >> Inspection End.

3. CHECK ABS ACTUATOR AND ELECTRIC UNIT (CONTROL UNIT) POWER SUPPLY AND GROUND CIRCUIT

Check the ABS actuator and electric unit (control unit) power supply and ground circuit. Refer to [EC-184, "Diagnosis Procedure"](#).

Is the inspection result normal?

- YES >> GO TO 4.
NO >> Repair / replace harness, connector, fuse, or fusible link.

4. CHECK TERMINAL

Check the ABS actuator and electric unit (control unit) pin terminals for damage or loose connection with harness connector.

Is the inspection result normal?

- YES >> Replace the ABS actuator and electric unit (control unit). Refer to [BRC-370, "Removal and Installation"](#).
NO >> Repair / replace harness, connector, or terminal.

C1142 PRESS SENSOR

< DTC/CIRCUIT DIAGNOSIS >

[WITH ICC]

C1142 PRESS SENSOR

DTC Description

INFOID:000000013458385

DTC DETECTION LOGIC

DTC	Display Item (Trouble diagnosis content)	Malfunction detected condition
C1142	PRESS SEN CIRCUIT (Pressure sensor circuit)	When a malfunction is detected in pressure sensor.

POSSIBLE CAUSE

NOTE:

Confirm if DTC is PAST or CRNT. If DTC is CRNT, proceed with Diagnosis Procedure. If DTC is PAST, clear DTC. Do not replace the ABS actuator and electric unit (control unit) for a PAST DTC.

PAST DTC	CRNT DTC
<ul style="list-style-type: none">• Harness or connector• Air inclusion in the brake piping• Stop lamp switch system• ABS actuator and electric unit (control unit) power supply system• Fuse• Fusible link• Battery	<ul style="list-style-type: none">• Stop lamp switch system• ABS actuator and electric unit (control unit)• Brake system• ABS actuator and electric unit (control unit) power supply system• Fuse• Fusible link• Battery• Air inclusion in the brake piping

DTC CONFIRMATION PROCEDURE

1. PRECONDITIONING

If "DTC CONFIRMATION PROCEDURE" has been previously conducted, always turn the ignition switch OFF and wait at least 10 seconds before conducting the next test.

>> GO TO 2.

2. CHECK DTC DETECTION

CONSULT

1. Turn the ignition switch OFF.
NOTE:
Wait at least 10 seconds after turning ignition switch OFF.
2. Start the engine.
NOTE:
Wait at least 10 seconds after start the engine.
3. Repeat step 1 to 2 two or more times.
4. Select "Self Diagnostic Result" mode of "ABS".

Is DTC "C1142" detected?

- YES-1 >> "CRNT" is displayed: Proceed to [BRC-305. "Diagnosis Procedure"](#).
YES-2 >> "PAST" is displayed: Inspection End (Erase the memory of self-diagnosis results.)
NO-1 >> To check malfunction symptom before repair: Refer to [GI-42. "Intermittent Incident"](#).
NO-2 >> Confirmation after repair: Inspection End.

Diagnosis Procedure

INFOID:000000013458386

1. CHECK STOP LAMP SWITCH SYSTEM

Check the stop lamp switch system. Refer to [BR-7. "Inspection"](#).

Is the inspection result normal?

- YES >> GO TO 2.
NO >> Repair or replace stop lamp switch system.

< DTC/CIRCUIT DIAGNOSIS >

2. CHECK BRAKE FLUID LEAKAGE

Check the brake fluid leakage. Refer to [BR-8, "Inspection"](#).

Is the inspection result normal?

YES >> GO TO 3.

NO >> Repair or replace brake fluid leakage part.

3. CHECK BRAKE PIPING

Check the brake piping.

- Front: Refer to [BR-22, "FRONT : Exploded View"](#).
- Rear: Refer to [BR-26, "REAR : Exploded View"](#).

Is the inspection result normal?

YES >> GO TO 4.

NO >> Repair or replace brake piping.

- Front: Refer to [BR-24, "FRONT : Removal and Installation"](#).
- Rear: Refer to [BR-27, "REAR : Removal and Installation"](#).

4. CHECK BRAKE PEDAL

Check the brake pedal.

- Brake pedal height: Refer to [BR-8, "Inspection"](#).
- Brake pedal assembly: Refer to [BR-8, "Inspection"](#).

Is the inspection result normal?

YES >> GO TO 5.

NO >> Adjust the brake pedal height or replace brake pedal assembly.

- Adjust the brake pedal: Refer to [BR-13, "Adjustment"](#).
- Replace the brake pedal: Refer to [BR-13, "Adjustment"](#).

5. CHECK BRAKE MASTER CYLINDER

Check the brake master cylinder. Refer to [BR-9, "Inspection"](#).

Is the inspection result normal?

YES >> GO TO 6.

NO >> Repair or replace brake master cylinder. Refer to [BR-29, "Removal and Installation"](#).

6. CHECK BRAKE BOOSTER

Check the brake booster. Refer to [BR-10, "Inspection"](#).

Is the inspection result normal?

YES >> GO TO 7.

NO >> Repair or replace brake booster. Refer to [BR-29, "Removal and Installation"](#).

7. CHECK VACUUM PIPING

Check the vacuum piping. Refer to [BR-34, "Exploded View"](#).

Is the inspection result normal?

YES >> GO TO 8.

NO >> Repair or replace vacuum piping. Refer to [BR-34, "Removal and Installation"](#).

8. CHECK FRONT DISC BRAKE

Check the front disc brake.

- [BR-18, "DISC BRAKE ROTOR : Inspection"](#).

Is the inspection result normal?

YES >> GO TO 9.

NO >> Repair or replace front disc brake.

- Refer to [BR-45, "DISC BRAKE ROTOR : Removal and Installation"](#).

9. CHECK REAR DISC BRAKE

Check the rear disc brake.

- Refer to [BR-18, "DISC BRAKE ROTOR : Inspection"](#).

Is the inspection result normal?

C1142 PRESS SENSOR

[WITH ICC]

< DTC/CIRCUIT DIAGNOSIS >

YES >> GO TO 10.

NO >> Repair or replace rear disc brake.

- Refer to [BR-45. "DISC BRAKE ROTOR : Removal and Installation"](#).

10. CHECK ABS ACTUATOR AND ELECTRIC UNIT (CONTROL UNIT) POWER SUPPLY AND GROUND CIRCUIT

Check the ABS actuator and electric unit (control unit) power supply and ground circuit. Refer to [BRC-275. "Diagnosis Procedure"](#).

Is the inspection result normal?

YES >> GO TO 11.

NO >> Repair / replace harness, connector, fuse, or fusible link.

11. CHECK ABS ACTUATOR AND ELECTRIC UNIT (CONTROL UNIT)

ⓂCONSULT

1. Erase "Self Diagnostic Result" mode of "ABS".

2. Turn the ignition switch OFF.

NOTE:

Wait at least 10 seconds after turning ignition switch OFF.

3. Start the engine.

NOTE:

Wait at least 10 seconds after start the engine.

4. Repeat step 2 to 3 two or more times.

5. Start the engine and drive the vehicle for a short period of time.

NOTE:

Vehicle must be driven after repair or replacement to erase the previous DTCs.

6. Stop the vehicle.

7. Select "Self Diagnostic Result" mode of "ABS".

Is DTC "C1142" detected?

YES >> Replace the ABS actuator and electric unit (control unit). Refer to [BRC-370. "Removal and Installation"](#).

NO >> Check the ABS actuator and electric unit (control unit) harness connector and terminal for damage, looseness and disconnection. Repair / replace harness, connector, or terminal.

A
B
C
D
E
BRC
G
H
I
J
K
L
M
N
O
P

C1143 STEERING ANGLE SENSOR

[WITH ICC]

< DTC/CIRCUIT DIAGNOSIS >

C1143 STEERING ANGLE SENSOR

DTC Description

INFOID:000000013458387

DTC DETECTION LOGIC

DTC	Display Item (Trouble diagnosis content)	Malfunction detected condition
C1143	ST ANG SEN CIRCUIT (Steering angle sensor circuit)	When a malfunction is detected in steering angle sensor.

POSSIBLE CAUSE

NOTE:

Confirm if DTC is PAST or CRNT. If DTC is CRNT, proceed with Diagnosis Procedure. If DTC is PAST, clear DTC. Do not replace the ABS actuator and electric unit (control unit) for a PAST DTC.

PAST DTC	CRNT DTC
<ul style="list-style-type: none">• Harness or connector• ABS actuator and electric unit (control unit) power supply system• Fuse• Fusible link• Battery• CAN communication line• Incomplete neutral position adjustment of steering angle sensor• Improper installation of steering angle sensor	<ul style="list-style-type: none">• Harness or connector• Steering angle sensor• ABS actuator and electric unit (control unit)• IPDM E/R• CAN communication line• Wheel alignment• Incomplete neutral position adjustment of steering angle sensor• ABS actuator and electric unit (control unit) power supply system• Fuse• Fusible link• Battery

DTC CONFIRMATION PROCEDURE

1. PRECONDITIONING

If "DTC CONFIRMATION PROCEDURE" has been previously conducted, always turn the ignition switch OFF and wait at least 10 seconds before conducting the next test.

>> GO TO 2.

2. CHECK DTC DETECTION

CONSULT

1. Turn the ignition switch OFF.

NOTE:

Wait at least 10 seconds after turning ignition switch OFF.

2. Start the engine.

NOTE:

Wait at least 10 seconds after start the engine.

3. Repeat step 1 to 2 two or more times.

4. Select "Self Diagnostic Result" mode of "ABS".

Is DTC "C1143" detected?

YES-1 >> "CRNT" is displayed: Proceed to [BRC-308, "Diagnosis Procedure"](#).

YES-2 >> "PAST" is displayed: Inspection End (Erase the memory of self-diagnosis results.)

NO-1 >> To check malfunction symptom before repair: Refer to [GI-42, "Intermittent Incident"](#).

NO-2 >> Confirmation after repair: Inspection End.

Diagnosis Procedure

INFOID:000000013458388

1. ADJUST THE NEUTRAL POSITION OF STEERING ANGLE SENSOR

CONSULT

Perform neutral position adjustment of steering angle sensor. Refer to [BRC-247, "Description"](#).

C1143 STEERING ANGLE SENSOR

< DTC/CIRCUIT DIAGNOSIS >

[WITH ICC]

>> GO TO 2.

2.PERFORM SELF DIAGNOSTIC RESULT (1)

CONSULT

1. Turn the ignition switch OFF.
NOTE:
Wait at least 10 seconds after turning ignition switch OFF.
2. Start the engine.
NOTE:
Wait at least 10 seconds after start the engine.
3. Repeat step 1 to 2 two or more times.
4. Select "Self Diagnostic Result" mode of "ABS".

Is DTC "C1143" detected?

YES-1 >> "CRNT" is displayed: GO TO 3.

YES-2 >> "PAST" is displayed: Inspection End (Erase the memory of self-diagnosis results.)

NO >> Inspection End.

3.CHECK CONNECTOR

1. Turn the ignition switch OFF.
2. Check the ABS actuator and electric unit (control unit) harness connector for disconnection or looseness.
3. Check the steering angle sensor harness connector for disconnection or looseness.

Is the inspection result normal?

YES >> GO TO 5.

NO >> Repair / replace harness or connector, securely lock the connector, and GO TO 4.

4.PERFORM SELF DIAGNOSTIC RESULT (2)

CONSULT

1. Turn the ignition switch OFF.
NOTE:
Wait at least 10 seconds after turning ignition switch OFF.
2. Start the engine.
NOTE:
Wait at least 10 seconds after start the engine.
3. Repeat step 1 to 2 two or more times.
4. Select "Self Diagnostic Result" mode of "ABS".

Is DTC "C1143" detected?

YES >> GO TO 5.

NO >> Inspection End.

5.CHECK STEERING ANGLE SENSOR POWER SUPPLY

1. Turn the ignition switch OFF.
2. Disconnect steering angle sensor harness connector.
3. Check the voltage between steering angle sensor harness connector and ground.

Steering angle sensor		—	Voltage (Approx.)
Connector	Terminal		
M54	4	Ground	Approx. 0 V

4. Turn the ignition switch ON.
NOTE:
Start the engine.
5. Check the voltage between steering angle sensor harness connector and ground.

C1143 STEERING ANGLE SENSOR

< DTC/CIRCUIT DIAGNOSIS >

[WITH ICC]

Steering angle sensor		—	Voltage (Approx.)
Connector	Terminal		
M54	4	Ground	Battery voltage (Approx.)

Is the inspection result normal?

YES >> GO TO 7.

NO >> GO TO 6.

6. CHECK STEERING ANGLE SENSOR POWER SUPPLY CIRCUIT

1. Turn the ignition switch OFF.
2. Check the 10A fuse (#46).
3. Disconnect IPDM E/R harness connector.
4. Check the continuity between steering angle sensor harness connector and IPDM E/R harness connector.

Steering angle sensor		IPDM E/R		Continuity
Connector	Terminal	Connector	Terminal	
M54	4	E119	35	Yes

5. Check the continuity between steering angle sensor harness connector and ground.

Steering angle sensor		—	Continuity
Connector	Terminal		
M54	4	Ground	No

Is the inspection result normal?

YES >> Perform trouble diagnosis for ignition power supply.

NO >> Repair / replace harness, connector, or fuse.

7. CHECK STEERING ANGLE SENSOR GROUND CIRCUIT

1. Turn the ignition switch OFF.
2. Check the continuity between steering angle sensor harness connector and ground.

Steering angle sensor		—	Continuity
Connector	Terminal		
M54	1	Ground	Yes

Is the inspection result normal?

YES >> GO TO 8.

NO >> Repair / replace harness or connector.

8. CHECK ABS ACTUATOR AND ELECTRIC UNIT (CONTROL UNIT) POWER SUPPLY AND GROUND CIRCUIT

Check the ABS actuator and electric unit (control unit) power supply and ground circuit. Refer to [BRC-275](#), "[Diagnosis Procedure](#)".

Is the inspection result normal?

YES >> GO TO 9.

NO >> Repair / replace harness, connector, fuse, or fusible link.

9. CHECK TERMINAL

1. Check the steering angle sensor pin terminals for damage or loose connection with harness connector.
2. Check the IPDM E/R pin terminals for damage or loose connection with harness connector.

Is the inspection result normal?

YES >> GO TO 10.

NO >> Repair / replace harness, connector, or terminal.

C1143 STEERING ANGLE SENSOR

[WITH ICC]

< DTC/CIRCUIT DIAGNOSIS >

10. CHECK CAN COMMUNICATION LINE

Check the CAN communication line. Refer to [LAN-11, "Precautions for Trouble Diagnosis"](#).

Is the inspection result normal?

YES >> GO TO 11.

NO >> Repair / replace harness or connector. Refer to [LAN-11, "Precautions for Harness Repair"](#).

11. CHECK DATA MONITOR

CONSULT

1. "ABS", "Data Monitor" and "STR ANGLE SIG" in this order.
2. Check that the indication changes with the steering angle when the steering wheel is turned left/right from the neutral position. Refer to [BRC-222, "Reference Value"](#).

Is the inspection result normal?

YES >> Replace the ABS actuator and electric unit (control unit). Refer to [BRC-370, "Removal and Installation"](#).

NO >> Replace the steering angle sensor. Refer to [BRC-373, "Removal and Installation"](#).

A
B
C
D
E
G
H
I
J
K
L
M
N
O
P

BRC

C1144 INCOMPLETE STEERING ANGLE SENSOR ADJUSTMENT

< DTC/CIRCUIT DIAGNOSIS >

[WITH ICC]

C1144 INCOMPLETE STEERING ANGLE SENSOR ADJUSTMENT

DTC Description

INFOID:000000013458389

DTC DETECTION LOGIC

DTC	Display Item (Trouble diagnosis content)	Malfunction detected condition
C1144	ST ANG SEN SIGNAL (Steering angle sensor not complete)	When neutral position adjustment of steering angle sensor is not complete.

POSSIBLE CAUSE

NOTE:

Confirm if DTC is PAST or CRNT. If DTC is CRNT, proceed with Diagnosis Procedure. If DTC is PAST, clear DTC. Do not replace the ABS actuator and electric unit (control unit) for a PAST DTC.

PAST DTC	CRNT DTC
Incomplete neutral position adjustment of steering angle sensor	<ul style="list-style-type: none">• Harness or connector• Steering angle sensor• ABS actuator and electric unit (control unit)• Incomplete neutral position adjustment of steering angle sensor

DTC CONFIRMATION PROCEDURE

1. PRECONDITIONING

If "DTC CONFIRMATION PROCEDURE" has been previously conducted, always turn the ignition switch OFF and wait at least 10 seconds before conducting the next test.

>> GO TO 2.

2. CHECK DTC DETECTION

CONSULT

1. Turn the ignition switch OFF.

NOTE:

Wait at least 10 seconds after turning ignition switch OFF.

2. Start the engine.

NOTE:

Wait at least 10 seconds after start the engine.

3. Repeat step 1 to 2 two or more times.
4. Select "Self Diagnostic Result" mode of "ABS".

Is DTC "C1144" detected?

YES-1 >> "CRNT" is displayed: Proceed to [BRC-312, "Diagnosis Procedure"](#).

YES-2 >> "PAST" is displayed: Inspection End (Erase the memory of "Self Diagnostic Result" mode of "ABS".)

NO-1 >> To check malfunction symptom before repair: Refer to [GI-42, "Intermittent Incident"](#).

NO-2 >> Confirmation after repair: Inspection End.

Diagnosis Procedure

INFOID:000000013458390

1. ADJUST THE NEUTRAL POSITION OF STEERING ANGLE SENSOR

Perform neutral position adjustment of steering angle sensor. Refer to [BRC-247, "Description"](#).

>> GO TO 2.

2. CHECK ABS ACTUATOR AND ELECTRIC UNIT (CONTROL UNIT)

CONSULT

1. Turn the ignition switch OFF.

C1144 INCOMPLETE STEERING ANGLE SENSOR ADJUSTMENT

< DTC/CIRCUIT DIAGNOSIS >

[WITH ICC]

NOTE:

Wait at least 10 seconds after turning ignition switch OFF.

2. Start the engine.

NOTE:

Wait at least 10 seconds after start the engine.

3. Repeat step 1 to 2 two or more times.
4. Select "Self Diagnostic Result" mode of "ABS".

Is DTC "C1144" detected?

YES >> GO TO 3.

NO >> Inspection End.

3.CHECK STEERING ANGLE SENSOR SYSTEM

1. Turn the ignition switch OFF.
2. Check the steering angle sensor system. Refer to [BRC-308. "Diagnosis Procedure"](#).

Is the inspection result normal?

YES >> GO TO 4.

NO >> Repair / replace harness, connector, or terminal.

4.CHECK DATA MONITOR

CONSULT

1. "ABS", "Data Monitor" and "STR ANGLE SIG" in this order.
2. Check that the indication changes with the steering angle when the steering wheel is turned left/right from the neutral position. Refer to [BRC-222. "Reference Value"](#).

Is the inspection result normal?

YES >> Replace the ABS actuator and electric unit (control unit). Refer to [BRC-370. "Removal and Installation"](#).

NO >> Replace the steering angle sensor. Refer to [BRC-373. "Removal and Installation"](#).

A
B
C
D
E
G
H
I
J
K
L
M
N
O
P

BRC

C1154 TRANSMISSION RANGE SWITCH

< DTC/CIRCUIT DIAGNOSIS >

[WITH ICC]

C1154 TRANSMISSION RANGE SWITCH

DTC Description

INFOID:000000013458391

DTC DETECTION LOGIC

DTC	Display Item (Trouble diagnosis content)	Malfunction detected condition
C1154	PNP POSI SIG (PNP position signal)	When a malfunction is detected in TCM system.

POSSIBLE CAUSE

NOTE:

Confirm if DTC is PAST or CRNT. If DTC is CRNT, proceed with Diagnosis Procedure. If DTC is PAST, clear the DTC. Do not replace the ABS actuator and electric unit (control unit) for a PAST DTC.

PAST DTC	CRNT DTC
<ul style="list-style-type: none">• Harness or connector• Transmission range switch	<ul style="list-style-type: none">• Harness or connector• ABS actuator and electric unit (control unit)• TCM• Transmission range switch

DTC CONFIRMATION PROCEDURE

1. PRECONDITIONING

If "DTC CONFIRMATION PROCEDURE" has been previously conducted, always turn the ignition switch OFF and wait at least 10 seconds before conducting the next test.

>> GO TO 2.

2. CHECK DTC DETECTION

CONSULT

1. Turn the ignition switch OFF.

NOTE:

Wait at least 10 seconds after turning ignition switch OFF.

2. Start the engine.

NOTE:

Wait at least 10 seconds after starting the engine.

3. Select "Self Diagnostic Result" mode of "ABS".

Is DTC "C1154" detected?

YES-1 >> "C1154" is displayed as "CRNT": Proceed to [BRC-314, "Diagnosis Procedure"](#).

YES-2 >> "C1154" is displayed as "PAST": Inspection End (Erase "Self Diagnostic Result" mode of "ABS".)

NO-1 >> To check malfunction symptom before repair: Refer to [GI-42, "Intermittent Incident"](#).

NO-2 >> Confirmation after repair: Inspection End.

Diagnosis Procedure

INFOID:000000013458392

CAUTION:

"C1154" may be detected when going up a slope, being towed with ignition switch ON and the shift selector in a position other than R position. This is not a shift position error. The system returns to normal once the vehicle is stopped, parked on level ground and the engine is started.

1. CHECK CVT SYSTEM

CONSULT

Select "Self Diagnostic Result" mode of "TRANSMISSION".

Is DTC detected?

YES >> Check the DTC. Refer to [TM-58, "DTC Index"](#) (RE0F10J).

NO >> GO TO 2.

C1154 TRANSMISSION RANGE SWITCH

< DTC/CIRCUIT DIAGNOSIS >

[WITH ICC]

2. PERFORM SELF-DIAGNOSIS

CONSULT

1. Erase "Self Diagnostic Result" mode of "ABS".
2. Turn the ignition switch OFF.

NOTE:

Wait at least 10 seconds after turning ignition switch OFF.

3. Start the engine.

NOTE:

Wait at least 10 seconds after starting the engine.

4. Drive the vehicle for a short period of time.

NOTE:

Vehicle must be driven after repair or replacement to erase the previous DTCs.

5. Stop the vehicle.
6. Select "Self Diagnostic Result" mode of "ABS".

Is DTC "C1154" detected?

- YES >> Replace the ABS actuator and electric unit (control unit). Refer to [BRC-370, "Removal and Installation"](#).
- NO >> Check pin terminals and connection of each harness connector for abnormal conditions. Repair / replace harness, connector, or terminal.

A
B
C
D
E
BRC
G
H
I
J
K
L
M
N
O
P

C1155 BRAKE FLUID LEVEL SWITCH

< DTC/CIRCUIT DIAGNOSIS >

[WITH ICC]

C1155 BRAKE FLUID LEVEL SWITCH

DTC Description

INFOID:000000013458393

DTC DETECTION LOGIC

DTC	Display Item (Trouble diagnosis content)	Malfunction detected condition
C1155	BR FLUID LEVEL LOW (Brake fluid level low)	<ul style="list-style-type: none">• When brake fluid level low signal is detected.• When an open circuit is detected in brake fluid level switch circuit.

POSSIBLE CAUSE

NOTE:

Confirm if DTC is PAST or CRNT. If DTC is CRNT, proceed with Diagnosis Procedure. If DTC is PAST, clear DTC. Do not replace the ABS actuator and electric unit (control unit) for a PAST DTC.

PAST DTC	CRNT DTC
<ul style="list-style-type: none">• Harness or connector• Brake fluid level is low	<ul style="list-style-type: none">• Harness or connector• ABS actuator and electric unit (control unit)• Brake fluid level switch• Combination meter• Unified meter and A/C amp.• IPDM E/R• Brake fluid level is low

DTC CONFIRMATION PROCEDURE

1. PRECONDITIONING

If "DTC CONFIRMATION PROCEDURE" has been previously conducted, always turn the ignition switch OFF and wait at least 10 seconds before conducting the next test.

>> GO TO 2.

2. CHECK DTC DETECTION

CONSULT

1. Turn the ignition switch OFF.
NOTE:
Wait at least 10 seconds after turning ignition switch OFF.
2. Start the engine.
NOTE:
Wait at least 10 seconds after start the engine.
3. Repeat step 1 to 2 two or more times.
4. Select "Self Diagnostic Result" mode of "ABS".

Is DTC "C1155" detected?

- YES-1 >> "CRNT" is displayed: Proceed to [BRC-316, "Diagnosis Procedure"](#).
- YES-2 >> "PAST" is displayed: Inspection End (Erase the memory of "Self Diagnostic Result" mode of "ABS".)
- NO-1 >> To check malfunction symptom before repair: Refer to [GI-42, "Intermittent Incident"](#).
- NO-2 >> Confirmation after repair: Inspection End.

Diagnosis Procedure

INFOID:000000013458394

1. CHECK BRAKE FLUID LEVEL

1. Turn the ignition switch OFF.
2. Check the brake fluid level. Refer to [BR-8, "Inspection"](#).

Is the inspection result normal?

- YES >> GO TO 3.
- NO >> Refill brake fluid. Refer to [BR-14, "Drain and Refill"](#). GO TO 2.

C1155 BRAKE FLUID LEVEL SWITCH

[WITH ICC]

< DTC/CIRCUIT DIAGNOSIS >

2. PERFORM SELF DIAGNOSTIC RESULT (1)

CONSULT

1. Erase "Self Diagnostic Result" mode of "ABS".
2. Turn the ignition switch OFF → ON → OFF.

NOTE:

Wait at least 10 seconds after turning ignition switch OFF or ON.

3. Start the engine.

NOTE:

Wait at least 10 seconds after start the engine.

4. Repeat step 2 to 3 two or more times.
5. Select "Self Diagnostic Result" mode of "ABS".

Is DTC "C1155" detected?

YES >> GO TO 3.

NO >> Inspection End.

3. CHECK CONNECTOR

1. Turn the ignition switch OFF.
2. Check the combination meter harness connector for disconnection or looseness.
3. Check the brake fluid level switch harness connector for disconnection or looseness.

Is the inspection result normal?

YES >> GO TO 5.

NO >> Repair / replace harness or connector, and GO TO 4.

4. PERFORM SELF DIAGNOSTIC RESULT (2)

CONSULT

1. Turn the ignition switch OFF.

NOTE:

Wait at least 10 seconds after turning ignition switch OFF.

2. Start the engine.

NOTE:

Wait at least 10 seconds after start the engine.

3. Repeat step 1 to 2 two or more times.
4. Select "Self Diagnostic Result" mode of "ABS".

Is DTC "C1155" detected?

YES >> GO TO 5.

NO >> Inspection End.

5. CHECK BRAKE FLUID LEVEL SWITCH

Check the brake fluid level switch. Refer to [BR-29, "Exploded View"](#).

Is the inspection result normal?

YES >> GO TO 7.

NO >> Replace the reservoir tank. Refer to [BR-32, "Exploded View"](#). GO TO 6.

6. PERFORM SELF DIAGNOSTIC RESULT (3)

CONSULT

1. Erase "Self Diagnostic Result" mode of "ABS".
2. Turn the ignition switch OFF → ON → OFF.

NOTE:

Wait at least 10 seconds after turning ignition switch OFF or ON.

3. Start the engine.

NOTE:

Wait at least 10 seconds after start the engine.

4. Repeat step 2 to 3 two or more times.
5. Select "Self Diagnostic Result" mode of "ABS".

Is DTC "C1155" detected?

YES >> GO TO 7.

NO >> Inspection End.

A

B

C

D

E

BRC

G

H

I

J

K

L

M

N

O

P

C1155 BRAKE FLUID LEVEL SWITCH

< DTC/CIRCUIT DIAGNOSIS >

[WITH ICC]

7. CHECK CONNECTOR AND TERMINAL

1. Turn the ignition switch OFF.
2. Disconnect brake fluid level switch harness connector.
3. Check the brake fluid level switch harness connector for disconnection or looseness.
4. Check the brake fluid level switch pin terminals for damage or loose connection with harness connector.
5. Disconnect combination meter harness connector.
6. Check the combination meter harness connector for disconnection or looseness.
7. Check the combination meter pin terminals for damage or loose connection with harness connector.

Is the inspection result normal?

YES >> GO TO 9.

NO >> Repair / replace harness, connector, or terminal, and GO TO 8.

8. PERFORM SELF DIAGNOSTIC RESULT (4)

CONSULT

1. Erase "Self Diagnostic Result" mode of "ABS".
2. Turn the ignition switch OFF → ON → OFF.

NOTE:

Wait at least 10 seconds after turning ignition switch OFF or ON.

3. Start the engine.

NOTE:

Wait at least 10 seconds after start the engine.

4. Repeat step 2 to 3 two or more times.
5. Select "Self Diagnostic Result" mode of "ABS".

Is DTC "C1155" detected?

YES >> GO TO 9.

NO >> Inspection End.

9. CHECK BRAKE FLUID LEVEL SWITCH CIRCUIT

1. Turn the ignition switch OFF.
2. Disconnect brake fluid level switch harness connector.
3. Disconnect combination meter harness connector.
4. Check the continuity between brake fluid level switch harness connector and combination meter harness connector.

Brake fluid level switch		Combination meter		Continuity
Connector	Terminal	Connector	Terminal	
E21	1	M24	25	Yes

5. Check the continuity between brake fluid level switch harness connector and ground.

Brake fluid level switch		—	Continuity
Connector	Terminal		
E21	1	Ground	No

Is the inspection result normal?

YES >> GO TO 10.

NO >> Repair / replace harness or connector, and GO TO 10.

10. CHECK BRAKE FLUID LEVEL SWITCH GROUND CIRCUIT

Check the continuity between brake fluid level switch harness connector and ground.

Brake fluid level switch		—	Continuity
Connector	Terminal		
E21	2	Ground	Yes

Is the inspection result normal?

YES >> GO TO 11.

C1155 BRAKE FLUID LEVEL SWITCH

[WITH ICC]

< DTC/CIRCUIT DIAGNOSIS >

NO >> Repair / replace harness or connector, and GO TO 11.

11.CHECK COMBINATION METER

Check the combination meter. Refer to [MWI-20, "CONSULT Function \(METER/M&A\)"](#).

Is the inspection result normal?

YES >> Replace the ABS actuator and electric unit (control unit). Refer to [BRC-370, "Removal and Installation"](#).

NO >> Repair or replace combination meter. Refer to [MWI-72, "Removal and Installation"](#).

Component Inspection

INFOID:000000013458395

1.CHECK BRAKE FLUID LEVEL SWITCH

1. Turn the ignition switch OFF.
2. Disconnect brake fluid level switch harness connector.
3. Check the continuity between terminals of brake fluid level switch.

Brake fluid level switch	Condition	Continuity
Terminal		
1-2	When brake fluid level in reservoir tank is within the specified level.	No
	When brake fluid level in reservoir tank is less than the specified level.	Yes

Is the inspection result normal?

YES >> Inspection End.

NO >> Replace the reservoir tank. Refer to [BR-30, "Disassembly and Assembly"](#).

C1160 INCOMPLETE DECEL G SENSOR CALIBRATION

< DTC/CIRCUIT DIAGNOSIS >

[WITH ICC]

C1160 INCOMPLETE DECEL G SENSOR CALIBRATION

DTC Description

INFOID:000000013458396

DTC DETECTION LOGIC

DTC	Display Item (Trouble diagnosis content)	Malfunction detected condition
C1160	DECEL G SEN SET (Decel G sensor set)	When calibration of yaw rate/side/decel G sensor is not complete.

POSSIBLE CAUSE

NOTE:

Confirm if DTC is PAST or CRNT. If DTC is CRNT, proceed with Diagnosis Procedure. If DTC is PAST, clear DTC. Do not replace the ABS actuator and electric unit (control unit) for a PAST DTC.

PAST DTC	CRNT DTC
<ul style="list-style-type: none">• Harness or connector• ABS actuator and electric unit (control unit) power supply system• Fuse• Fusible link• Battery	<ul style="list-style-type: none">• Incomplete calibration of decel G sensor• ABS actuator and electric unit (control unit)

DTC CONFIRMATION PROCEDURE

1. PRECONDITIONING

If "DTC CONFIRMATION PROCEDURE" has been previously conducted, always turn the ignition switch OFF and wait at least 10 seconds before conducting the next test.

>> GO TO 2.

2. CHECK DTC DETECTION

CONSULT

1. Turn the ignition switch OFF.

NOTE:

Wait at least 10 seconds after turning ignition switch OFF.

2. Start the engine.

NOTE:

Wait at least 10 seconds after start the engine.

3. Repeat step 1 to 2 two or more times.
4. Select "Self Diagnostic" mode of "ABS".

Is DTC "C1160" detected?

YES-1 >> "CRNT" is displayed: Proceed to [BRC-320, "Diagnosis Procedure"](#).

YES-2 >> "PAST" is displayed: Inspection End (Erase the memory of "Self Diagnostic" mode of "ABS".)

NO-1 >> To check malfunction symptom before repair: Refer to [GI-42, "Intermittent Incident"](#).

NO-2 >> Confirmation after repair: Inspection End.

Diagnosis Procedure

INFOID:000000013458397

1. CALIBRATION OF DECEL G SENSOR

Perform calibration of decel G sensor. Refer to [BRC-64, "Work Procedure"](#).

>> GO TO 2.

2. CHECK ABS ACTUATOR AND ELECTRIC UNIT (CONTROL UNIT)

CONSULT

1. Turn the ignition switch OFF.

C1160 INCOMPLETE DECEL G SENSOR CALIBRATION

[WITH ICC]

< DTC/CIRCUIT DIAGNOSIS >

NOTE:

Wait at least 10 seconds after turning ignition switch OFF.

2. Start the engine.

NOTE:

Wait at least 10 seconds after start the engine.

3. Repeat step 1 to 2 two or more times.
4. Select "Self Diagnostic Result" mode of "ABS".

Is DTC "C1160" detected?

YES >> Replace the ABS actuator and electric unit (control unit). Refer to [BRC-172. "Removal and Installation"](#).

NO >> Inspection End.

A
B
C
D
E
G
H
I
J
K
L
M
N
O
P

BRC

C1164, C1165 CV SYSTEM

DTC Description

INFOID:000000013458398

DTC DETECTION LOGIC

DTC	Display Item (Trouble diagnosis content)	Malfunction detected condition
C1164	CV 1 (Cut valve 1)	When a malfunction is detected in cut valve 1.
C1165	CV 2 (Cut valve 2)	When a malfunction is detected in cut valve 2.

POSSIBLE CAUSE

NOTE:

Confirm if DTC is PAST or CRNT. If DTC is CRNT, proceed with Diagnosis Procedure. If DTC is PAST, clear DTC. Do not replace the ABS actuator and electric unit (control unit) for a PAST DTC.

PAST DTC	CRNT DTC
<ul style="list-style-type: none"> • Harness or connector • ABS actuator and electric unit (control unit) power supply system • Fuse • Fusible link • Battery 	<ul style="list-style-type: none"> • Harness or connector • ABS actuator and electric unit (control unit) • ABS actuator and electric unit (control unit) power supply system • Fuse • Fusible link • Battery

DTC CONFIRMATION PROCEDURE

1. PRECONDITIONING

If "DTC CONFIRMATION PROCEDURE" has been previously conducted, always turn the ignition switch OFF and wait at least 10 seconds before conducting the next test.

>> GO TO 2.

2. CHECK DTC DETECTION

CONSULT

1. Turn the ignition switch OFF.
NOTE:
Wait at least 10 seconds after turning ignition switch OFF.
2. Start the engine.
NOTE:
Wait at least 10 seconds after start the engine.
3. Repeat step 1 to 2 two or more times.
4. Select "Self Diagnostic Result" mode of "ABS".

Is DTC "C1164" or "C1165" detected?

- YES-1 >> "C1164" or "C1165" is displayed by "CRNT": Proceed to [BRC-322, "Diagnosis Procedure"](#).
- YES-2 >> "C1164" and "C1165" are displayed by "PAST": Inspection End (Erase the memory of "Self Diagnostic Result" mode of "ABS".)
- NO-1 >> To check malfunction symptom before repair: Refer to [GI-42, "Intermittent Incident"](#).
- NO-2 >> Confirmation after repair: Inspection End.

Diagnosis Procedure

INFOID:000000013458399

1. CHECK CONNECTOR

1. Turn the ignition switch OFF.
2. Check the ABS actuator and electric unit (control unit) harness connector for disconnection or looseness.

Is the inspection result normal?

C1164, C1165 CV SYSTEM

[WITH ICC]

< DTC/CIRCUIT DIAGNOSIS >

YES >> GO TO 3.

NO >> Repair / replace harness or connector, securely lock the connector, and GO TO 2.

2.PERFORM SELF-DIAGNOSIS

CONSULT

Select "Self Diagnostic Result" mode of "ABS" again.

Is DTC "C1164" or "C1165" detected?

YES >> GO TO 3.

NO >> Inspection End.

3.CHECK ABS ACTUATOR AND ELECTRIC UNIT (CONTROL UNIT) POWER SUPPLY AND GROUND CIRCUIT

Check the ABS actuator and electric unit (control unit) power supply and ground circuit. Refer to [BRC-275, "Diagnosis Procedure"](#).

Is the inspection result normal?

YES >> GO TO 4.

NO >> Repair / replace harness, connector, fuse, or fusible link.

4.CHECK TERMINAL

Check the ABS actuator and electric unit (control unit) pin terminals for damage or loose connection with harness.

Is the inspection result normal?

YES >> Replace the ABS actuator and electric unit (control unit). Refer to [BRC-172, "Removal and Installation"](#).

NO >> Repair / replace harness, connector, or terminal.

A
B
C
D
E
BRC
G
H
I
J
K
L
M
N
O
P

C1166, C1167 SV SYSTEM

DTC Description

INFOID:000000013458400

DTC DETECTION LOGIC

DTC	Display Item (Trouble diagnosis content)	Malfunction detected condition
C1166	SV 1 (Suction valve 1)	When a malfunction is detected in suction valve 1.
C1167	SV 2 (Suction valve 2)	When a malfunction is detected in suction valve 2.

POSSIBLE CAUSE

NOTE:

Confirm if DTC is PAST or CRNT. If DTC is CRNT, proceed with Diagnosis Procedure. If DTC is PAST, clear DTC. Do not replace the ABS actuator and electric unit (control unit) for a PAST DTC.

PAST DTC	CRNT DTC
<ul style="list-style-type: none"> • Harness or connector • ABS actuator and electric unit (control unit) power supply system • Fuse • Fusible link • Battery 	<ul style="list-style-type: none"> • Harness or connector • ABS actuator and electric unit (control unit) • ABS actuator and electric unit (control unit) power supply system • Fuse • Fusible link • Battery

DTC CONFIRMATION PROCEDURE

1. PRECONDITIONING

If "DTC CONFIRMATION PROCEDURE" has been previously conducted, always turn the ignition switch OFF and wait at least 10 seconds before conducting the next test.

>> GO TO 2.

2. CHECK DTC DETECTION

CONSULT

1. Turn the ignition switch OFF.
NOTE:
Wait at least 10 seconds after turning ignition switch OFF.
2. Start the engine.
NOTE:
Wait at least 10 seconds after start the engine.
3. Repeat step 1 to 2 two or more times.
4. Select "Self Diagnostic Result" mode of "ABS".

Is DTC "C1166" or "C1167" detected?

- YES-1 >> "C1166" or "C1167" is displayed by "CRNT": Proceed to [BRC-324, "Diagnosis Procedure"](#).
- YES-2 >> "C1166" and "C1167" is displayed by "PAST": Inspection End. (Erase the memory of "Self Diagnostic Result" mode of "ABS".)
- NO-1 >> To check malfunction symptom before repair: Refer to [GI-42, "Intermittent Incident"](#).
- NO-2 >> Confirmation after repair: Inspection End.

Diagnosis Procedure

INFOID:000000013458401

1. CHECK CONNECTOR

1. Turn the ignition switch OFF.
 2. Check the ABS actuator and electric unit (control unit) harness connector for disconnection or looseness.
- Is the inspection result normal?

C1166, C1167 SV SYSTEM

[WITH ICC]

< DTC/CIRCUIT DIAGNOSIS >

YES >> GO TO 3.

NO >> Repair / replace harness or connector, securely lock the connector, and GO TO 2.

2.PERFORM SELF DIAGNOSTIC RESULT

CONSULT

Select "Self Diagnostic Result" mode of "ABS" again.

Is DTC "C1166" or "C1167" detected?

YES >> GO TO 3.

NO >> Inspection End.

3.CHECK ABS ACTUATOR AND ELECTRIC UNIT (CONTROL UNIT) POWER SUPPLY AND GROUND CIRCUIT

Check the ABS actuator and electric unit (control unit) power supply and ground circuit. Refer to [BRC-275, "Diagnosis Procedure"](#).

Is the inspection result normal?

YES >> GO TO 4.

NO >> Repair / replace harness, connector, fuse, or fusible link.

4.CHECK TERMINAL

Check the ABS actuator and electric unit (control unit) pin terminals for damage or loose connection with harness.

Is the inspection result normal?

YES >> Replace the ABS actuator and electric unit (control unit). Refer to [BRC-172, "Removal and Installation"](#).

NO >> Repair / replace harness, connector, or terminal.

A
B
C
D
E
BRC
G
H
I
J
K
L
M
N
O
P

C1170 VARIANT CODING

[WITH ICC]

< DTC/CIRCUIT DIAGNOSIS >

C1170 VARIANT CODING

DTC Description

INFOID:000000013458402

DTC DETECTION LOGIC

DTC	Display Item (Trouble diagnosis content)	Malfunction detected condition
C1170	VARIANT CODING (Variant coding)	When the information in ABS actuator and electric unit (control unit) is not the same.

POSSIBLE CAUSE

NOTE:

Confirm if DTC is PAST or CRNT. If DTC is CRNT, proceed with Diagnosis Procedure. If DTC is PAST, clear DTC. Do not replace the ABS actuator and electric unit (control unit) for a PAST DTC.

PAST DTC	CRNT DTC
—	<ul style="list-style-type: none">• ABS actuator and electric unit (control unit)• ABS actuator and electric unit (control unit) is not configured.

DTC CONFIRMATION PROCEDURE

1. PRECONDITIONING

If "DTC CONFIRMATION PROCEDURE" has been previously conducted, always turn the ignition switch OFF and wait at least 10 seconds before conducting the next test.

>> GO TO 2.

2. CHECK DTC DETECTION

CONSULT

1. Turn the ignition switch OFF.

NOTE:

Wait at least 10 seconds after turning ignition switch OFF.

2. Start the engine.

NOTE:

Wait at least 10 seconds after start the engine.

3. Select "Self Diagnostic Result" mode of "ABS".

Is DTC "C1170" detected?

YES-1 >> "CRNT" is displayed: Proceed to [BRC-326, "Diagnosis Procedure"](#).

YES-2 >> "PAST" is displayed: Inspection End (Erase the memory of self-diagnosis results.)

NO-1 >> To check malfunction symptom before repair: Refer to [GI-42, "Intermittent Incident"](#).

NO-2 >> Confirmation after repair: Inspection End.

Diagnosis Procedure

INFOID:000000013458403

1. CONFIGURATION OF ABS ACTUATOR AND ELECTRIC UNIT (CONTROL UNIT)

Perform configuration of ABS actuator and electric unit (control unit). Refer to [BRC-66, "Work Procedure"](#).

CAUTION:

Never replace the ABS actuator and electric unit (control unit).

>> GO TO 2.

2. CHECK SELF-DIAGNOSIS RESULTS

CONSULT

Replace the ABS actuator and electric unit (control unit) even if other DTC are displayed along with "C1170" in self-diagnosis for "ABS".

C1170 VARIANT CODING

< DTC/CIRCUIT DIAGNOSIS >

[WITH ICC]

>> Replace the ABS actuator and electric unit (control unit). Refer to [BRC-370, "Removal and Installation"](#).

A

B

C

D

E

BRC

G

H

I

J

K

L

M

N

O

P

C1197 VACUUM SENSOR

< DTC/CIRCUIT DIAGNOSIS >

[WITH ICC]

C1197 VACUUM SENSOR

DTC Description

INFOID:000000013458404

DTC DETECTION LOGIC

DTC	Display Item (Trouble diagnosis content)	Malfunction detected condition
C1197	VACUUM SENSOR (Vacuum sensor)	When a malfunction is detected in vacuum sensor.

POSSIBLE CAUSE

NOTE:

Confirm if DTC is PAST or CRNT. If DTC is CRNT, proceed with Diagnosis Procedure. If DTC is PAST, clear DTC. Do not replace the ABS actuator and electric unit (control unit) for a PAST DTC.

PAST DTC	CRNT DTC
<ul style="list-style-type: none">• Harness or connector• ABS actuator and electric unit (control unit) power supply system• Fuse• Fusible link• Battery	<ul style="list-style-type: none">• Harness or connector• Vacuum sensor (brake booster)• Vacuum piping• ABS actuator and electric unit (control unit)

DTC CONFIRMATION PROCEDURE

1. PRECONDITIONING

If "DTC CONFIRMATION PROCEDURE" has been previously conducted, always turn the ignition switch OFF and wait at least 10 seconds before conducting the next test.

>> GO TO 2.

2. CHECK DTC DETECTION

CONSULT

1. Turn the ignition switch OFF.
NOTE:
Wait at least 10 seconds after turning ignition switch OFF.
2. Start the engine.
NOTE:
Wait at least 10 seconds after start the engine.
3. Select "Self Diagnostic Result" mode of "ABS".

Is DTC "C1197" detected?

- YES-1 >> "CRNT" is displayed: Proceed to [BRC-328, "Diagnosis Procedure"](#).
YES-2 >> "PAST" is displayed: Inspection End (Erase the memory of self-diagnosis results.)
NO-1 >> To check malfunction symptom before repair: Refer to [GI-42, "Intermittent Incident"](#).
NO-2 >> Confirmation after repair: Inspection End.

Diagnosis Procedure

INFOID:000000013458405

1. CHECK CONNECTOR

1. Turn the ignition switch OFF.
2. Check the vacuum sensor harness connector for disconnection or looseness.
3. Check the ABS actuator and electric unit (control unit) harness connector for disconnection or looseness.

Is the inspection result normal?

- YES >> GO TO 2.
NO >> Repair / replace harness or connector, and GO TO 2.

2. CHECK BRAKE BOOSTER

1. Turn the ignition switch OFF.

C1197 VACUUM SENSOR

[WITH ICC]

< DTC/CIRCUIT DIAGNOSIS >

2. Check the brake booster. Refer to [BR-10, "Inspection"](#).

Is the inspection result normal?

YES >> GO TO 3.

NO >> Replace the brake booster. Refer to [BR-32, "Removal and Installation"](#).

3. CHECK VACUUM PIPING

Check the vacuum piping. Refer to [BR-34, "Exploded View"](#).

Is the inspection result normal?

YES >> GO TO 4.

NO >> Replace the vacuum piping. Refer to [BR-34, "Removal and Installation"](#).

4. CHECK TERMINAL

1. Turn the ignition switch OFF.
2. Disconnect vacuum sensor harness connector.
3. Check the vacuum sensor pin terminals for damage or loose connection with harness connector.
4. Disconnect ABS actuator and electric unit (control unit) harness connector.
5. Check the ABS actuator and electric unit (control unit) pin terminals for damage or loose connection with harness connector.

Is the inspection result normal?

YES >> GO TO 5.

NO >> Repair / replace harness, connector, or terminal.

5. CHECK VACUUM SENSOR CIRCUIT

1. Turn the ignition switch OFF.
2. Disconnect vacuum sensor harness connector.
3. Disconnect ABS actuator and electric unit (control unit) harness connector.
4. Check the continuity between vacuum sensor harness connector and ABS actuator and electric unit (control unit) harness connector.

Vacuum sensor		ABS actuator and electric unit (control unit)		Continuity
Connector	Terminal	Connector	Terminal	
E167	1	E130	22	Yes
	2		20	
	3		21	

5. Check the continuity between vacuum sensor harness connector and ground.

Vacuum sensor		—	Continuity
Connector	Terminal		
E167	1	Ground	No
	2		
	3		

Is the inspection result normal?

YES >> GO TO 6.

NO >> Repair / replace harness or connector.

6. REPLACE VACUUM SENSOR

Ⓜ CONSULT

1. Connect ABS actuator and electric unit (control unit) harness connector.
2. Replace the vacuum sensor.

CAUTION:

Always replace brake booster because vacuum sensor cannot be disassembled. Refer to [BR-32, "Removal and Installation"](#).

3. Erase "Self Diagnostic Result" mode of "ABS".
4. Turn the ignition switch OFF → ON → OFF.

NOTE:

A
B
C
D
E
G
H
I
J
K
L
M
N
O
P

BRC

C1197 VACUUM SENSOR

[WITH ICC]

< DTC/CIRCUIT DIAGNOSIS >

Wait at least 10 seconds after turning ignition switch OFF or ON.

5. Start engine.

NOTE:

Wait at least 10 seconds after start the engine.

6. Select "Self Diagnostic Result" mode of "ABS".

Is DTC "C1197" detected?

YES >> Replace the ABS actuator and electric unit (control unit). Refer to [BRC-370. "Removal and Installation"](#).

NO >> Inspection End.

C1198 VACUUM SENSOR

< DTC/CIRCUIT DIAGNOSIS >

[WITH ICC]

C1198 VACUUM SENSOR

DTC Description

INFOID:000000013458406

DTC DETECTION LOGIC

DTC	Display Item (Trouble diagnosis content)	Malfunction detected condition
C1198	VACUUM SEN CIR (Vacuum sensor circuit)	<ul style="list-style-type: none"> When an open circuit is detected in vacuum sensor circuit. When a short circuit is detected in vacuum sensor circuit. When a malfunction is detected in vacuum sensor noise.

POSSIBLE CAUSE

NOTE:

Confirm if DTC is PAST or CRNT. If DTC is CRNT, proceed with Diagnosis Procedure. If DTC is PAST, clear DTC. Do not replace the ABS actuator and electric unit (control unit) for a PAST DTC.

PAST DTC	CRNT DTC
<ul style="list-style-type: none"> Harness or connector ABS actuator and electric unit (control unit) power supply system Fuse Fusible link Battery 	<ul style="list-style-type: none"> Harness or connector Vacuum sensor (brake booster) ABS actuator and electric unit (control unit)

DTC CONFIRMATION PROCEDURE

1. PRECONDITIONING

If "DTC CONFIRMATION PROCEDURE" has been previously conducted, always turn the ignition switch OFF and wait at least 10 seconds before conducting the next test.

>> GO TO 2.

2. CHECK DTC DETECTION

CONSULT

- Turn the ignition switch OFF.

NOTE:

Wait at least 10 seconds after turning ignition switch OFF.

- Start the engine.

NOTE:

Wait at least 10 seconds after start the engine.

- Select "Self Diagnostic Result" mode of "ABS".

Is DTC "C1198" detected?

YES-1 >> "CRNT" is displayed: Proceed to [BRC-331, "Diagnosis Procedure"](#).

YES-2 >> "PAST" is displayed: Inspection End (Erase the memory of self-diagnosis results.)

NO-1 >> To check malfunction symptom before repair: Refer to [GI-42, "Intermittent Incident"](#).

NO-2 >> Confirmation after repair: Inspection End.

Diagnosis Procedure

INFOID:000000013458407

1. CHECK CONNECTOR

- Turn the ignition switch OFF.
- Check the vacuum sensor harness connector for disconnection or looseness.
- Check the ABS actuator and electric unit (control unit) harness connector for disconnection or looseness.

Is the inspection result normal?

YES >> GO TO 2.

NO >> Repair / replace harness or connector, and GO TO 2.

2. CHECK TERMINAL

C1198 VACUUM SENSOR

[WITH ICC]

< DTC/CIRCUIT DIAGNOSIS >

1. Turn the ignition switch OFF.
2. Disconnect vacuum sensor harness connector.
3. Check the vacuum sensor pin terminals for damage or loose connection with harness connector.
4. Disconnect ABS actuator and electric unit (control unit) harness connector.
5. Check the ABS actuator and electric unit (control unit) pin terminals for damage or loose connection with harness connector.

Is the inspection result normal?

YES >> GO TO 3.

NO >> Repair / replace harness, connector, or terminal.

3. CHECK VACUUM SENSOR CIRCUIT

1. Turn the ignition switch OFF.
2. Disconnect vacuum sensor harness connector.
3. Disconnect ABS actuator and electric unit (control unit) harness connector.
4. Check the continuity between vacuum sensor harness connector and ABS actuator and electric unit (control unit) harness connector.

Vacuum sensor		ABS actuator and electric unit (control unit)		Continuity
Connector	Terminal	Connector	Terminal	
E167	1	E125	12	Yes
	2		24	
	3		5	

5. Check the continuity between vacuum sensor harness connector and ground.

Vacuum sensor		—	Continuity
Connector	Terminal		
E167	1	Ground	No
	2		
	3		

Is the inspection result normal?

YES >> GO TO 4.

NO >> Repair / replace harness or connector.

4. REPLACE VACUUM SENSOR

Ⓟ CONSULT

1. Connect ABS actuator and electric unit (control unit) harness connector.
2. Replace the vacuum sensor.

CAUTION:

Always replace brake booster because vacuum sensor cannot be disassembled. Refer to [BR-32, "Removal and Installation"](#).

3. Erase "Self Diagnostic Result" mode of "ABS".
4. Turn the ignition switch OFF → ON → OFF.

NOTE:

Wait at least 10 seconds after turning ignition switch OFF or ON.

5. Start engine.

NOTE:

Wait at least 10 seconds after start the engine.

6. Select "Self Diagnostic Result" mode of "ABS".

Is DTC "C1198" detected?

YES >> Replace the ABS actuator and electric unit (control unit). Refer to [BRC-172, "Removal and Installation"](#).

NO >> Inspection End.

C1199 BRAKE BOOSTER

[WITH ICC]

< DTC/CIRCUIT DIAGNOSIS >

C1199 BRAKE BOOSTER

DTC Description

INFOID:000000013458408

DTC DETECTION LOGIC

DTC	Display Item (Trouble diagnosis content)	Malfunction detected condition
C1199	BRAKE BOOSTER (Brake booster)	When brake booster vacuum is approx. 0 kPa (0 mmHg) during engine running.

POSSIBLE CAUSE

NOTE:

Confirm if DTC is PAST or CRNT. If DTC is CRNT, proceed with Diagnosis Procedure. If DTC is PAST, clear DTC. Do not replace the ABS actuator and electric unit (control unit) for a PAST DTC.

PAST DTC	CRNT DTC
<ul style="list-style-type: none"> • Harness or connector • ABS actuator and electric unit (control unit) power supply system • Fuse • Fusible link • Battery 	<ul style="list-style-type: none"> • Harness or connector • Vacuum sensor (brake booster) • Vacuum piping • ABS actuator and electric unit (control unit)

DTC CONFIRMATION PROCEDURE

1. PRECONDITIONING

If "DTC CONFIRMATION PROCEDURE" has been previously conducted, always turn the ignition switch OFF and wait at least 10 seconds before conducting the next test.

>> GO TO 2.

2. CHECK DTC DETECTION

CONSULT

1. Turn the ignition switch OFF.

NOTE:

Wait at least 10 seconds after turning ignition switch OFF.

2. Start the engine.

NOTE:

Wait at least 10 seconds after start the engine.

3. Select "Self Diagnostic Result" mode of "ABS".

Is DTC "C1199" detected?

YES-1 >> "CRNT" is displayed: Proceed to [BRC-333. "Diagnosis Procedure"](#).

YES-2 >> "PAST" is displayed: Inspection End (Erase the memory of self-diagnosis results.)

NO-1 >> To check malfunction symptom before repair: Refer to [GI-42. "Intermittent Incident"](#).

NO-2 >> Confirmation after repair: Inspection End.

Diagnosis Procedure

INFOID:000000013458409

1. CHECK CONNECTOR

1. Turn the ignition switch OFF.
2. Check the vacuum sensor harness connector for disconnection or looseness.
3. Check the ABS actuator and electric unit (control unit) harness connector for disconnection or looseness.

Is the inspection result normal?

YES >> GO TO 2.

NO >> Repair / replace harness or connector, and GO TO 2.

2. CHECK BRAKE BOOSTER

C1199 BRAKE BOOSTER

[WITH ICC]

< DTC/CIRCUIT DIAGNOSIS >

1. Turn the ignition switch OFF.
2. Check the brake booster. Refer to [BR-10, "Inspection"](#).

Is the inspection result normal?

YES >> GO TO 3.

NO >> Replace the brake booster. Refer to [BR-32, "Removal and Installation"](#).

3. CHECK VACUUM PIPING

Check the vacuum piping. Refer to [BR-34, "Exploded View"](#).

Is the inspection result normal?

YES >> GO TO 4.

NO >> Replace the vacuum piping. Refer to [BR-34, "Removal and Installation"](#).

4. CHECK TERMINAL

1. Turn the ignition switch OFF.
2. Disconnect vacuum sensor harness connector.
3. Check the vacuum sensor pin terminals for damage or loose connection with harness connector.
4. Disconnect ABS actuator and electric unit (control unit) harness connector.
5. Check the ABS actuator and electric unit (control unit) pin terminals for damage or loose connection with harness connector.

Is the inspection result normal?

YES >> GO TO 5.

NO >> Repair / replace harness, connector, or terminal.

5. CHECK VACUUM SENSOR CIRCUIT

1. Turn the ignition switch OFF.
2. Disconnect vacuum sensor harness connector.
3. Disconnect ABS actuator and electric unit (control unit) harness connector.
4. Check the continuity between vacuum sensor harness connector and ABS actuator and electric unit (control unit) harness connector.

Vacuum sensor		ABS actuator and electric unit (control unit)		Continuity
Connector	Terminal	Connector	Terminal	
E167	1	E125	12	Yes
	2		24	
	3		5	

5. Check the continuity between vacuum sensor harness connector and ground.

Vacuum sensor		—	Continuity
Connector	Terminal		
E167	1	Ground	No
	2		
	3		

Is the inspection result normal?

YES >> GO TO 6.

NO >> Repair / replace harness or connector.

6. REPLACE VACUUM SENSOR

ⓐ CONSULT

1. Connect ABS actuator and electric unit (control unit) harness connector.
2. Replace the vacuum sensor.

CAUTION:

Always replace brake booster because vacuum sensor cannot be disassembled. Refer to [BR-32, "Removal and Installation"](#).

3. Erase "Self Diagnostic Result" mode of "ABS".
4. Turn the ignition switch OFF → ON → OFF.

C1199 BRAKE BOOSTER

[WITH ICC]

< DTC/CIRCUIT DIAGNOSIS >

NOTE:

Wait at least 10 seconds after turning ignition switch OFF or ON.

5. Start engine.

NOTE:

Wait at least 10 seconds after start the engine.

6. Select "Self Diagnostic Result" mode of "ABS".

Is DTC "C1199" detected?

YES >> Replace the ABS actuator and electric unit (control unit). Refer to [BRC-172, "Removal and Installation"](#).

NO >> Inspection End.

A
B
C
D
E
G
H
I
J
K
L
M
N
O
P

BRC

C119A VACUUM SENSOR

< DTC/CIRCUIT DIAGNOSIS >

[WITH ICC]

C119A VACUUM SENSOR

DTC Description

INFOID:000000013458410

DTC DETECTION LOGIC

DTC	Display Item (Trouble diagnosis content)	Malfunction detected condition
C119A	VACUUM SEN VOLT (Vacuum sensor voltage)	When a malfunction is detected in supply power voltage of vacuum sensor.

POSSIBLE CAUSE

NOTE:

Confirm if DTC is PAST or CRNT. If DTC is CRNT, proceed with Diagnosis Procedure. If DTC is PAST, clear DTC. Do not replace the ABS actuator and electric unit (control unit) for a PAST DTC.

PAST DTC	CRNT DTC
<ul style="list-style-type: none">• Harness or connector• ABS actuator and electric unit (control unit) power supply system• Fuse• Fusible link• Battery	<ul style="list-style-type: none">• Harness or connector• Vacuum sensor (brake booster)• ABS actuator and electric unit (control unit)• ABS actuator and electric unit (control unit) power supply system• Fuse• Fusible link• Battery

DTC CONFIRMATION PROCEDURE

1. PRECONDITIONING

If "DTC CONFIRMATION PROCEDURE" has been previously conducted, always turn the ignition switch OFF and wait at least 10 seconds before conducting the next test.

>> GO TO 2.

2. CHECK DTC DETECTION

ⓅCONSULT

1. Turn the ignition switch OFF.

NOTE:

Wait at least 10 seconds after turning ignition switch OFF.

2. Start the engine.

NOTE:

Wait at least 10 seconds after start the engine.

3. Select "Self Diagnostic Result" mode of "ABS".

Is DTC "C119A" detected?

YES-1 >> "CRNT" is displayed: Proceed to [BRC-336, "Diagnosis Procedure"](#).

YES-2 >> "PAST" is displayed: Inspection End (Erase the memory of self-diagnosis results.)

NO-1 >> To check malfunction symptom before repair: Refer to [GI-42, "Intermittent Incident"](#).

NO-2 >> Confirmation after repair: Inspection End.

Diagnosis Procedure

INFOID:000000013458411

1. CHECK CONNECTOR

1. Turn the ignition switch OFF.
2. Check the vacuum sensor harness connector for disconnection or looseness.
3. Check the ABS actuator and electric unit (control unit) harness connector for disconnection or looseness.

Is the inspection result normal?

YES >> GO TO 2.

NO >> Repair / replace harness or connector, and GO TO 2.

C119A VACUUM SENSOR

[WITH ICC]

< DTC/CIRCUIT DIAGNOSIS >

2. CHECK VACUUM SENSOR POWER SUPPLY

1. Turn the ignition switch OFF.
2. Disconnect vacuum sensor harness connector.
3. Check the voltage between vacuum sensor harness connector and ground.

+		-	Voltage (Approx.)
Vacuum sensor			
Connector	Terminal		
E167	3	Ground	0 V

4. Turn the ignition switch ON.
NOTE:
 Start the engine.
5. Check the voltage between vacuum sensor harness connector and ground.

+		-	Voltage (Approx.)
Vacuum sensor			
Connector	Terminal		
E167	3	Ground	Battery voltage

Is the inspection result normal?

- YES >> GO TO 4.
 NO >> GO TO 3.

3. CHECK VACUUM SENSOR POWER SUPPLY CIRCUIT

1. Turn the ignition switch OFF.
2. Disconnect ABS actuator and electric unit (control unit) harness connector.
3. Check the continuity between vacuum sensor harness connector and ABS actuator and electric unit (control unit) harness connector.

Vacuum sensor		ABS actuator and electric unit (control unit)		Continuity
Connector	Terminal	Connector	Terminal	
E167	3	E130	21	Yes

4. Check the continuity between vacuum sensor harness connector and ground.

Vacuum sensor		-	Continuity
Connector	Terminal		
E167	3	Ground	No

Is the inspection result normal?

- YES >> GO TO 4.
 NO >> Repair / replace harness or connector.

4. CHECK VACUUM SENSOR GROUND CIRCUIT

1. Turn the ignition switch OFF.
2. Check the continuity between vacuum sensor harness connector and ground.

Vacuum sensor		-	Continuity
Connector	Terminal		
E167	3	Ground	No

Is the inspection result normal?

- YES >> GO TO 5.
 NO >> Repair / replace harness or connector.

C119A VACUUM SENSOR

[WITH ICC]

< DTC/CIRCUIT DIAGNOSIS >

5. CHECK ABS ACTUATOR AND ELECTRIC UNIT (CONTROL UNIT) POWER SUPPLY AND GROUND CIRCUIT

Check the ABS actuator and electric unit (control unit) power supply and ground circuit. Refer to [BRC-275. "Diagnosis Procedure"](#).

Is the inspection result normal?

YES >> GO TO 6.

NO >> Repair / replace harness, connector, fuse, or fusible link.

6. CHECK TERMINAL

1. Check the vacuum sensor pin terminals for damage or loose connection with harness connector.
2. Check the ABS actuator and electric unit (control unit) pin terminals for damage or loose connection with harness connector.

Is the inspection result normal?

YES >> Replace the ABS actuator and electric unit (control unit). Refer to [BRC-370. "Removal and Installation"](#).

NO >> Repair / replace harness, connector, or terminal.

U1000 CAN COMM CIRCUIT

< DTC/CIRCUIT DIAGNOSIS >

[WITH ICC]

U1000 CAN COMM CIRCUIT

DTC Description

INFOID:000000013458412

DTC DETECTION LOGIC

DTC	Display Item (Trouble diagnosis content)	Malfunction detected condition
U1000	CAN COMM CIRCUIT (CAN communication circuit)	When CAN communication signal is not continuously transmitted or received for 2 seconds or more.

POSSIBLE CAUSE

NOTE:

Confirm if DTC is PAST or CRNT. If DTC is CRNT, proceed with Diagnosis Procedure. If DTC is PAST, clear DTC. Do not replace the ABS actuator and electric unit (control unit) for a PAST DTC.

PAST DTC	CRNT DTC
<ul style="list-style-type: none">• Harness or connector• CAN communication line	CAN communication system malfunction

DTC CONFIRMATION PROCEDURE

1. PRECONDITIONING

If "DTC CONFIRMATION PROCEDURE" has been previously conducted, always turn the ignition switch OFF and wait at least 10 seconds before conducting the next test.

>> GO TO 2.

2. CHECK DTC DETECTION

CONSULT

1. Turn the ignition switch OFF.

NOTE:

Wait at least 10 seconds after turning ignition switch OFF.

2. Start the engine.

NOTE:

Wait at least 10 seconds after start the engine.

3. Repeat step 1 to 2 two or more times.
4. Select "Self Diagnostic Result" mode of "ABS".

Is DTC "U1000" detected?

YES-1 >> "CRNT" is displayed: Proceed to [BRC-339, "Diagnosis Procedure"](#).

YES-2 >> "PAST" is displayed: Inspection End (Erase the memory of "Self Diagnostic Result" mode of "ABS".)

NO-1 >> To check malfunction symptom before repair: Refer to [GI-42, "Intermittent Incident"](#).

NO-2 >> Confirmation after repair: Inspection End.

Diagnosis Procedure

INFOID:000000013458413

Proceed to [LAN-21, "Trouble Diagnosis Flow Chart"](#).

U1002 SYSTEM COMM (CAN)

< DTC/CIRCUIT DIAGNOSIS >

[WITH ICC]

U1002 SYSTEM COMM (CAN)

DTC Description

INFOID:000000013458414

DTC DETECTION LOGIC

DTC	Display item (Trouble diagnosis content)	Malfunction detected condition
U1002	SYSTEM COMM (CAN) (CAN system communication)	When ABS actuator and electric unit (control unit) is not transmitting or receiving CAN communication signal for 2 seconds or less.

POSSIBLE CAUSE

NOTE:

Confirm if DTC is PAST or CRNT. If DTC is CRNT, proceed with Diagnosis Procedure. If DTC is PAST, clear the DTC. Do not replace the ABS actuator and electric unit (control unit) for a PAST DTC.

PAST DTC	CRNT DTC
<ul style="list-style-type: none">CAN communication lineHarness or connector	<ul style="list-style-type: none">CAN communication lineABS actuator and electric unit (control unit)Steering angle sensor

DTC CONFIRMATION PROCEDURE

1. PRECONDITIONING

If "DTC CONFIRMATION PROCEDURE" has been previously conducted, always turn the ignition switch OFF and wait at least 10 seconds before conducting the next test.

>> GO TO 2.

2. DTC REPRODUCTION PROCEDURE

CONSULT

1. Turn the ignition switch OFF.

NOTE:

Wait at least 10 seconds after turning ignition switch OFF.

2. Start the engine.

NOTE:

Wait at least 10 seconds after starting the engine.

3. Select "Self Diagnostic Result" mode of "ABS".

Is DTC "U1002" detected?

YES-1 >> "CRNT" is displayed: Proceed to [BRC-340, "Diagnosis Procedure"](#).

YES-2 >> "PAST" is displayed: Inspection End (Erase "Self Diagnostic Result" of "ABS").

NO-1 >> To check malfunction symptom before repair: Refer to [GI-42, "Intermittent Incident"](#).

NO-2 >> Confirmation after repair: Inspection End.

Diagnosis Procedure

INFOID:000000013458415

CAUTION:

- Never apply 7.0 V or more to the measurement terminal.
- Use a tester with open terminal voltage of 7.0 V or less.
- Turn the ignition switch OFF and disconnect the battery cable from the negative terminal when checking the harness.

1. CHECK CAN DIAGNOSIS SUPPORT MONITOR

CONSULT

1. Select "CAN Diagnosis Support Monitor" of "ABS".
2. Check the malfunction history between each control unit connected to ABS actuator and electric unit (control unit).

Check the result of "PAST"?

U1002 SYSTEM COMM (CAN)

[WITH ICC]

< DTC/CIRCUIT DIAGNOSIS >

All items are "OK">>Check the intermittent incident. Refer to [GI-42. "Intermittent Incident"](#).

"TRANSMIT DIAG" is other than "OK">>GO TO 2.

A control unit other than ABS actuator and electric unit (control unit) is anything other than "OK">>GO TO 3.

2.CHECK TRANSMITTING SIDE UNIT

Check the ABS actuator and electric unit (control unit) harness connector terminals No. 14 and 26 for damage or loose connection.

Is the inspection result normal?

YES >> Erase "Self Diagnostic Result" mode of "ABS". Then select "Self Diagnostic Result" of "ABS" using CONSULT.

NO >> Recheck the terminals for damage or loose connection.

3.CHECK APPLICABLE CONTROL UNIT

Check the terminals of each harness connector for damage or loose connection.

Is the inspection result normal?

YES >> Erase "Self Diagnostic Result" mode of applicable control unit. Then perform "Self Diagnostic Result" of applicable control unit using CONSULT.

NO >> Recheck the terminals for damage or loose connection.

A
B
C
D
E
G
H
I
J
K
L
M
N
O
P

BRC

POWER SUPPLY AND GROUND CIRCUIT

[WITH ICC]

< DTC/CIRCUIT DIAGNOSIS >

POWER SUPPLY AND GROUND CIRCUIT

Diagnosis Procedure

INFOID:000000013461027

Regarding Wiring Diagram information, refer to [PCS-23. "Wiring Diagram"](#).

1. CHECK FUSIBLE LINKS

Check that the following fusible links are not blown.

Signal name	Fusible link No.
Battery power supply	E (80A)
	A (250A), C (80A)
	A (250A), B (100A), N (40A)

Is the fusible link blown?

YES >> Replace the blown fusible link after repairing the affected circuit.

NO >> GO TO 2.

2. CHECK POWER SUPPLY CIRCUIT

1. Disconnect IPDM E/R connectors E118 and E120.
2. Check voltage between IPDM E/R connectors and ground.

IPDM E/R		Ground	Voltage (Approx.)
Connector	Terminal		
E118	1	—	Battery voltage
	2		
E120	3		

Is the inspection result normal?

YES >> GO TO 3.

NO >> Repair or replace harness or connectors.

3. CHECK GROUND CIRCUIT

1. Disconnect IPDM E/R connectors E119 and E121.
2. Check continuity between IPDM E/R connectors and ground.

IPDM E/R		Ground	Continuity
Connector	Terminal		
E121	7	—	Yes
E119	41		

Is the inspection result normal?

YES >> Inspection End.

NO >> Repair or replace harness or connectors.

PARKING BRAKE SWITCH

[WITH ICC]

< DTC/CIRCUIT DIAGNOSIS >

PARKING BRAKE SWITCH

Component Function Check

INFOID:000000012894628

1.CHECK PARKING BRAKE SWITCH OPERATION

Check that brake warning lamp in combination meter turns ON/OFF when parking brake is operated.

Is the inspection result normal?

- YES >> Inspection End.
- NO >> Proceed to [BRC-343, "Diagnosis Procedure"](#).

Diagnosis Procedure

INFOID:000000012894629

1.CHECK PARKING BRAKE SWITCH CIRCUIT

1. Turn the ignition switch OFF.
2. Disconnect parking brake switch harness connector.
3. Disconnect combination meter harness connector.
4. Check the continuity between parking brake switch harness connector and combination meter harness connector.

Parking brake switch		Combination meter		Continuity
Connector	Terminal	Connector	Terminal	
E52	1	M24	26	Yes

5. Check the continuity between parking brake switch harness connector and ground.

Parking brake switch		—	Continuity
Connector	Terminal		
E52	1	Ground	No

Is the inspection result normal?

- YES >> GO TO 2.
- NO >> Repair or replace error-detected parts.

2.CHECK PARKING BRAKE SWITCH

Check the parking brake switch. Refer to [PB-4, "Inspection and Adjustment"](#).

Is the inspection result normal?

- YES >> GO TO 3.
- NO >> Replace the parking brake switch. Refer to [PB-10, "Removal and Installation"](#).

3.CHECK PARKING BRAKE SWITCH SIGNAL

ⓂWith CONSULT

1. Select "Data Monitor"
2. Select "PARK BRAKE SW".
3. Check that the function operates normally according to the following conditions:

Condition	Data Monitor
Operate parking brake	On
Release parking brake	Off

Is the inspection result normal?

- YES >> Inspection End.
- NO >> GO TO 4.

4.CHECK COMBINATION METER

Check the combination meter. Refer to [MWI-20, "CONSULT Function \(METER/M&A\)"](#).

Is the inspection result normal?

PARKING BRAKE SWITCH

[WITH ICC]

< DTC/CIRCUIT DIAGNOSIS >

YES >> GO TO 5.

NO >> Repair or replace combination meter. Refer to [MWI-72, "Removal and Installation"](#).

5.CHECK TERMINAL

1. Check the combination meter pin terminals for damage or loose connection with harness connector.
2. Check the parking brake switch pin terminals for damage or loose connection with harness connector.

Is the inspection result normal?

YES >> Replace the ABS actuator and electric unit (control unit). Refer to [BRC-370, "Removal and Installation"](#).

NO >> Repair or replace error-detected parts.

Component Inspection

INFOID:000000012894630

1.CHECK PARKING BRAKE SWITCH

1. Turn the ignition switch OFF.
2. Disconnect parking brake switch harness connector.
3. Check the continuity between parking brake switch terminal and ground.

Parking brake switch Terminal	—	Condition	Continuity
1	Ground	When parking brake switch is pressed	Yes
		When parking brake switch is released	No

Is the inspection result normal?

YES >> Inspection End.

NO >> Replace the parking brake switch. Refer to [PB-10, "Removal and Installation"](#).

VDC OFF SWITCH

< DTC/CIRCUIT DIAGNOSIS >

[WITH ICC]

VDC OFF SWITCH

Component Function Check

INFOID:000000012894631

1. CHECK VDC OFF SWITCH OPERATION

Check that VDC OFF indicator lamp in combination meter turns ON/OFF when VDC OFF switch is operated.

Is the inspection result normal?

- YES >> Inspection End.
- NO >> Proceed to [BRC-345, "Diagnosis Procedure"](#).

Diagnosis Procedure

INFOID:000000012894632

1. CHECK VDC OFF SWITCH CIRCUIT

1. Turn the ignition switch OFF.
2. Disconnect ABS actuator and electric unit (control unit) harness connector.
3. Disconnect VDC OFF switch harness connector.
4. Check the continuity between ABS actuator and electric unit (control unit) harness connector and VDC OFF switch harness connector.

ABS actuator and electric unit (control unit)		VDC OFF switch		Continuity
Connector	Terminal	Connector	Terminal	
E130	9	M71	6	Yes

5. Check the continuity between ABS actuator and electric unit (control unit) harness connector and ground.

ABS actuator and electric unit (control unit)		—	Continuity
Connector	Terminal		
E130	9	Ground	No

Is the inspection result normal?

- YES >> GO TO 2.
- NO >> Repair or replace error-detected parts.

2. CHECK VDC OFF SWITCH GROUND CIRCUIT

Check the continuity between VDC OFF switch harness connector and ground.

VDC OFF switch		—	Continuity
Connector	Terminal		
M71	8	Ground	Yes

Is the inspection result normal?

- YES >> GO TO 3.
- NO >> Repair or replace error-detected parts.

3. CHECK VDC OFF SWITCH

Check the VDC OFF switch. Refer to [BRC-346, "Component Inspection"](#).

Is the inspection result normal?

- YES >> GO TO 4.
- NO >> Replace the VDC OFF switch. Refer to [BRC-372, "Removal and Installation"](#).

4. CHECK VDC OFF SWITCH SIGNAL

CONSULT

1. Select "Data Monitor" mode of "ABS".
2. Select "OFF SW".
3. Check that the function operates normally according to the following conditions:

VDC OFF SWITCH

< DTC/CIRCUIT DIAGNOSIS >

[WITH ICC]

Condition	Data Monitor
When VDC OFF switch is pressed and VDC OFF indicator lamp in combination meter is in ON status	On
When VDC OFF switch is pressed and VDC OFF indicator lamp in combination meter is in OFF status	Off

Is the inspection result normal?

- YES >> Inspection End.
NO >> GO TO 5.

5.CHECK TERMINAL

1. Check the ABS actuator and electric unit (control unit) pin terminals for damage or loose connection with harness connector.
2. Check the VDC OFF switch pin terminals for damage or loose connection with harness connector.

Is the inspection result normal?

- YES >> Replace the ABS actuator and electric unit (control unit). Refer to [BRC-370, "Removal and Installation"](#).
NO >> Repair or replace error-detected parts.

Component Inspection

INFOID:0000000012894633

1.CHECK VDC OFF SWITCH

1. Turn the ignition switch OFF.
2. Disconnect VDC OFF switch harness connector.
3. Check the continuity between terminals of VDC OFF switch connector.

VDC OFF switch	Condition	Continuity
Terminal		
6- 8	When VDC OFF switch is pressed	Yes
	When VDC OFF switch is not pressed	No

Is the inspection result normal?

- YES >> Inspection End.
NO >> Replace the VDC OFF switch. Refer to [BRC-174, "Removal and Installation"](#).

ABS WARNING LAMP

[WITH ICC]

< DTC/CIRCUIT DIAGNOSIS >

ABS WARNING LAMP

Component Function Check

INFOID:0000000012894634

1. CHECK ABS WARNING LAMP FUNCTION

Check that ABS warning lamp in combination meter turns ON for 1 second after ignition switch is turned ON.

CAUTION:

Never start the engine.

Is the inspection result normal?

YES >> Inspection End.

NO >> Proceed to [BRC-347, "Diagnosis Procedure"](#).

Diagnosis Procedure

INFOID:0000000012894635

1. CHECK ABS ACTUATOR AND ELECTRIC UNIT (CONTROL UNIT) POWER SUPPLY AND GROUND CIRCUIT

Perform the trouble diagnosis for ABS actuator and electric unit (control unit) power supply and ground circuit. Refer to [BRC-347, "Diagnosis Procedure"](#).

Is the inspection result normal?

YES >> GO TO 2.

NO >> Repair or replace error-detected parts.

2. PERFORM SELF DIAGNOSTIC RESULT

CONSULT

1. Turn the ignition switch OFF → ON.

CAUTION:

- Be sure to wait 10 seconds after turning ignition switch OFF or ON.
- Start the engine.

2. Repeat step 1 two or more times.

3. Perform "Self Diagnostic Result" for "ABS".

Is any DTC detected?

YES >> Check the DTC. Refer to [BRC-228, "DTC Index"](#).

NO >> GO TO 3.

3. CHECK ABS WARNING LAMP SIGNAL

CONSULT

1. Select "ABS", "Data Monitor" and "ABS WARN LAMP" in this order.

2. Turn the ignition switch OFF.

3. Check that data monitor displays "On" for 1 second after ignition switch is turned ON and then changes to "Off".

CAUTION:

Never start the engine.

Is the inspection result normal?

YES >> Replace the combination meter. Refer to [MWI-72, "Removal and Installation"](#).

NO >> Replace the ABS actuator and electric unit (control unit). Refer to [BRC-370, "Removal and Installation"](#).

BRAKE WARNING LAMP

Component Function Check

INFOID:000000012894636

1.CHECK BRAKE WARNING LAMP FUNCTION

Check that brake warning lamp in combination meter turns ON for 1 second after ignition switch is turned ON.

CAUTION:

Never start the engine.

Is the inspection result normal?

YES >> GO TO 2.

NO >> Proceed to [BRC-348, "Diagnosis Procedure"](#).

2.CHECK BRAKE WARNING LAMP FUNCTION

Check that brake warning lamp turns ON/OFF when parking brake is operated.

NOTE:

Brake warning lamp turns ON when parking brake is operated (when parking brake switch is ON).

Is the inspection result normal?

YES >> GO TO 3.

NO >> Check the parking brake switch system. Refer to [BRC-343, "Diagnosis Procedure"](#).

3.CHECK BRAKE WARNING LAMP FUNCTION

Check that brake warning lamp in combination meter turns ON/OFF when brake fluid level switch is operated while brake fluid level in reservoir tank is within the specified level.

NOTE:

Brake warning lamp turns ON when brake fluid is less than the specified level (when brake fluid level switch is ON).

Is the inspection result normal?

YES >> Inspection End.

NO >> Check the brake fluid level switch system. Refer to [BR-29, "Exploded View"](#).

Diagnosis Procedure

INFOID:000000012894637

1.CHECK ABS ACTUATOR AND ELECTRIC UNIT (CONTROL UNIT) POWER SUPPLY AND GROUND CIRCUIT

Perform the trouble diagnosis for ABS actuator and electric unit (control unit) power supply and ground circuits. Refer to [BRC-275, "Diagnosis Procedure"](#).

Is the inspection result normal?

YES >> GO TO 2.

NO >> Repair or replace error-detected parts.

2.PERFORM THE SELF DIAGNOSTIC RESULT

CONSULT

1. Turn the ignition switch OFF → ON.

CAUTION:

- Be sure to wait 10 seconds after turning ignition switch OFF or ON.
- Start the engine.

2. Repeat step 1 two or more times.

3. Perform "Self Diagnostic Result" mode of "ABS".

Is any DTC detected?

YES >> Check the DTC. Refer to [BRC-228, "DTC Index"](#).

NO >> GO TO 3.

3.CHECK BRAKE WARNING LAMP SIGNAL

CONSULT

1. Select "ABS", "Data Monitor" mode and "EBD WARN LAMP" in this order.

2. Turn the ignition switch OFF.

BRAKE WARNING LAMP

[WITH ICC]

< DTC/CIRCUIT DIAGNOSIS >

3. Check that data monitor displays “On” for 1 second after ignition switch is turned ON and then changes to “Off”.

CAUTION:

Never start the engine.

Is the inspection result normal?

- YES >> Replace the combination meter. Refer to [MWI-72, "Removal and Installation"](#).
NO >> Replace the ABS actuator and electric unit (control unit). Refer to [BRC-372, "Removal and Installation"](#).

A
B
C
D
E
G
H
I
J
K
L
M
N
O
P

BRC

VDC WARNING LAMP

Component Function Check

INFOID:000000012894638

1.CHECK VDC WARNING LAMP FUNCTION

Check that VDC warning lamp in combination meter turns ON for 1 second after ignition switch is turned ON.

CAUTION:

Never start the engine.

Is the inspection result normal?

YES >> Inspection End.

NO >> Proceed to [BRC-350, "Diagnosis Procedure"](#).

Diagnosis Procedure

INFOID:000000012894639

1.CHECK ABS ACTUATOR AND ELECTRIC UNIT (CONTROL UNIT) POWER SUPPLY AND GROUND CIRCUIT

Perform the trouble diagnosis for ABS actuator and electric unit (control unit) power supply and ground circuits. Refer to [BRC-275, "Diagnosis Procedure"](#).

Is the inspection result normal?

YES >> GO TO 2.

NO >> Repair or replace error-detected parts.

2.PERFORM THE SELF DIAGNOSTIC RESULT

CONSULT

1. Turn the ignition switch OFF → ON.

CAUTION:

- **Be sure to wait 10 seconds after turning ignition switch OFF or ON.**
- **Start the engine.**

2. Repeat step 1 two or more times.

3. Perform "Self Diagnostic Result" mode of "ABS".

Is any DTC detected?

YES >> Check the DTC. Refer to [BRC-51, "DTC Index"](#).

NO >> GO TO 3.

3.CHECK VDC WARNING LAMP SIGNAL

CONSULT

1. Select "ABS", "Data Monitor" and "SLIP/VDC LAMP" in this order.

2. Turn the ignition switch OFF.

3. Check that data monitor displays "On" for approximately 1 second after ignition switch is turned ON and then changes to "Off".

CAUTION:

Never start the engine.

Is the inspection result normal?

YES >> Replace the combination meter. Refer to [MWI-72, "Removal and Installation"](#).

NO >> Replace the ABS actuator and electric unit (control unit). Refer to [BRC-370, "Removal and Installation"](#).

VDC OFF INDICATOR LAMP

< DTC/CIRCUIT DIAGNOSIS >

[WITH ICC]

VDC OFF INDICATOR LAMP

Component Function Check

INFOID:000000012894640

1. CHECK VDC OFF INDICATOR LAMP FUNCTION (1)

Check that VDC OFF indicator lamp in combination meter turns ON for 1 second after ignition switch is turned ON.

CAUTION:

Never start the engine.

Is the inspection result normal?

YES >> GO TO 2.

NO >> Proceed to [BRC-351, "Diagnosis Procedure"](#).

2. CHECK VDC OFF INDICATOR LAMP FUNCTION (2)

Check that VDC OFF indicator lamp in combination meter turns ON/OFF when VDC OFF switch is operated.

Is the inspection result normal?

YES >> Inspection End.

NO >> Check the VDC OFF switch system. Refer to [BRC-345, "Diagnosis Procedure"](#).

Diagnosis Procedure

INFOID:000000012894641

1. CHECK ABS ACTUATOR AND ELECTRIC UNIT (CONTROL UNIT) POWER SUPPLY AND GROUND CIRCUIT

Perform the trouble diagnosis for ABS actuator and electric unit (control unit) power supply and ground circuits. Refer to [BRC-275, "Diagnosis Procedure"](#).

Is the inspection result normal?

YES >> GO TO 2.

NO >> Repair or replace error-detected parts.

2. CHECK VDC OFF INDICATOR LAMP SIGNAL

ⓂCONSULT

1. Select "ABS", "Data Monitor" and "OFF LAMP" in this order.

2. Turn the ignition switch OFF.

3. Check that data monitor displays "On" for 1 second after ignition switch is turned ON and then changes to "Off".

CAUTION:

Never start the engine.

Is the inspection result normal?

YES >> GO TO 3.

NO >> Replace the ABS actuator and electric unit (control unit). Refer to [BRC-370, "Removal and Installation"](#).

3. CHECK VDC OFF INDICATOR LAMP SIGNAL

ⓂCONSULT

1. Select "ABS", "Data Monitor" and "OFF LAMP" in this order.

2. Check that data monitor displays "On" or "Off" each time VDC OFF switch is operated.

Is the inspection result normal?

YES >> Replace the combination meter. Refer to [MWI-72, "Removal and Installation"](#).

NO >> Check the VDC OFF switch system. Refer to [BRC-345, "Diagnosis Procedure"](#).

FORWARD EMERGENCY BRAKING

< DTC/CIRCUIT DIAGNOSIS >

[WITH ICC]

FORWARD EMERGENCY BRAKING

Diagnosis Procedure

INFOID:000000012894642

1. FORWARD EMERGENCY BRAKING DIAGNOSIS

- The system will be cancelled automatically with a beep sound and FEB warning lamp on the combination meter will illuminate, when the system will not operate properly.
- When the FEB warning lamp continues to illuminate even if the FEB system is turned on after the engine restarts, perform the trouble-diagnosis.

>> Go to ICC. Refer to [CCS-54, "Work Flow"](#).

DRIVER ASSISTANCE SYSTEM SYMPTOMS

< SYMPTOM DIAGNOSIS >

[WITH ICC]

SYMPTOM DIAGNOSIS

DRIVER ASSISTANCE SYSTEM SYMPTOMS

Symptom Table

INFOID:0000000012894643

Before performing diagnosis, check that it is not a symptom caused by normal operation. Refer to [BRC-207, "BRAKE ASSIST \(WITH PREVIEW FUNCTION\) : System Description-Forward Emergency Braking"](#).

Symptom	Confirmation item	Inspection item/Reference page
FEB system display does not illuminate	All of system display does not illuminate	System settings cannot be turned ON/OFF Refer to BRC-354, "Diagnosis Procedure"
	Other information display is not illuminated	Combination meter Refer to MWI-29, "DTC Index"
FEB warning lamp does not illuminate	All of system display does not illuminate	System settings cannot be turned ON/OFF Refer to BRC-354, "Diagnosis Procedure"
	Other information display is not illuminated	Combination meter Refer to MWI-29, "DTC Index"
FEB warning buzzer is not sounding (Warning display is functioning normally)	—	Chime does not sound. Refer to WCS-5, "WARNING CHIME SYSTEM : System Description" .

A
B
C
D
E
BRC
G
H
I
J
K
L
M
N
O
P

SYSTEM SETTINGS CANNOT BE TURNED ON/OFF ON THE INTEGRAL SWITCH

< SYMPTOM DIAGNOSIS >

[WITH ICC]

SYSTEM SETTINGS CANNOT BE TURNED ON/OFF ON THE INTEGRAL SWITCH

Symptom Table

INFOID:000000012894644

CAUTION:

Perform the “Self Diagnostic Result” with CONSULT before the symptom diagnosis. Perform the trouble diagnosis if any DTC is detected.

Symptom		Inspection item/Reference page
FEB system does not turn ON/OFF	FEB warning lamp is not turned ON↔OFF when operating integral switch	BRC-354. "Diagnosis Procedure"

Description

INFOID:000000012894645

FEB system does not turn ON/OFF.

- FEB warning lamp does not illuminate even if the integral switch is operated when FEB warning lamp is not illuminated.
- FEB warning lamp does not turn off even if the integral switch is operated when FEB warning lamp is illuminated.

NOTE:

The system ON/OFF condition will be memorized even if the ignition switch turns OFF.

Diagnosis Procedure

INFOID:000000012894646

1.PERFORM SELF DIAGNOSTIC RESULT (LASER/RADAR)

1. Perform “Self Diagnostic Result” mode of “ICC/ADAS” with CONSULT.
2. Check if the DTC is detected in “Self Diagnostic Result” mode of “ICC/ADAS” with CONSULT. Refer to [CCS-46. "DTC Index"](#).

Is any DTC detected?

- YES >> GO TO 9.
NO >> GO TO 2.

2.STEERING SWITCH INSPECTION

1. Start the engine.
2. Check that “FEB SELECT” operates normally in “Data Monitor” of “LASER/RADAR” with CONSULT.

Is inspection result normal?

- YES >> GO TO 6.
NO >> GO TO 3.

3.CHECK STEERING SWITCH RESISTANCE

Check resistance between the following steering switch terminals:

Steering switches		Condition	Resistance (Ω) (Approx.)
Terminal	Signal name		
17	Display	Depress ▷ switch.	2023
	Back	Depress ◁ switch.	723
16	Enter	Depress OK switch.	2023
	Menu Up	Depress △ switch.	121
	Menu Down	Depress ▽ switch.	321

Is the inspection result normal?

- YES >> GO TO 4.
NO >> Replace steering wheel switch. Refer to [CCS-136. "Removal and Installation"](#).

4.CHECK SPIRAL CABLE

SYSTEM SETTINGS CANNOT BE TURNED ON/OFF ON THE INTEGRAL SWITCH

< SYMPTOM DIAGNOSIS >

[WITH ICC]

Check continuity between the following spiral cable terminals:

Spiral cable		Continuity
Terminal		
16	9	Yes
17	8	
19	11	

Is the inspection result normal?

YES >> GO TO 5.

NO >> Replace spiral cable. Refer to [SR-15. "Removal and Installation"](#).

5. CHECK STEERING SWITCH CIRCUIT

1. Turn ignition switch OFF.
2. Disconnect combination meter harness connector M24 and spiral cable harness connector M30.
3. Check continuity between combination meter harness connector M24 and spiral cable harness connector M30.

Combination meter		Spiral cable		Continuity
Connector	Terminal	Connector	Terminal	
M24	21	M30	11	Yes
	22		9	
	23		8	

4. Check continuity between combination meter harness connector M24 and ground.

Combination meter		Ground	Continuity
Connector	Terminal		
M24	21	Ground	No
	22		
	23		

Is the inspection result normal?

YES >> GO TO 6.

NO >> Repair or replace harness or connector.

6. PERFORM THE DIAGNOSTIC RESULT (METER/M&A)

1. Perform "Self Diagnostic Result" mode of "METER/M&A" with CONSULT.
2. Check if the DTC is detected in "Self Diagnostic Result" mode of "METER/M&A" with CONSULT. Refer to [MWI-29. "DTC Index"](#).

Is any DTC detected?

YES >> GO TO 9.

NO >> GO TO 7.

7. FEB WARNING LAMP

1. Select the active test item "METER LAMP" of "ICC/ADAS".
2. Check if the FEB warning lamp illuminates when the test item is operated.

Is inspection result normal?

YES >> Refer to [CCS-54. "Work Flow"](#).

NO >> GO TO 8.

8. CHECK DATA MONITOR OF COMBINATION METER

Check that "BA W/L operates normally in "Data Monitor" mode of "METER/M&A".

Is inspection result normal?

YES >> Replace the combination meter. Refer to [MWI-72. "Removal and Installation"](#).

NO >> Replace the ICC sensor. Refer to [CCS-134. "Removal and Installation"](#).

SYSTEM SETTINGS CANNOT BE TURNED ON/OFF ON THE INTEGRAL SWITCH

< SYMPTOM DIAGNOSIS >

[WITH ICC]

9.REPAIR OR REPLACE MALFUNCTIONING PARTS

Repair or replace malfunctioning parts.

>> GO TO 10.

10.CHECK FEB SYSTEM

Check that FEB warning lamp turned ON⇔OFF, when operating steering switch.

>> Inspection End.

EXCESSIVE OPERATION FREQUENCY

< SYMPTOM DIAGNOSIS >

[WITH ICC]

EXCESSIVE OPERATION FREQUENCY

Description

INFOID:000000012894647

VDC function, TCS function, ABS function, EBD function, brake assist function or hill start assist function operates in excessive operation frequency.

Diagnosis Procedure

INFOID:000000012894648

1. CHECK BRAKING FORCE

Check brake force using a brake tester.

Is the inspection result normal?

YES >> GO TO 2.

NO >> Check brake system.

2. CHECK FRONT AND REAR AXLE

Check that there is no excessive looseness in front and rear axle.
Refer to [FAX-6, "Inspection"](#) (front) or [RAX-6, "Inspection"](#) (rear).

Is the inspection result normal?

YES >> GO TO 3.

NO >> Repair or replace error-detected parts.

3. CHECK WHEEL SENSOR

Check wheel sensor.

- Check installation and damage of wheel sensor.
- Check connection of wheel sensor harness connector.
- Check terminal of wheel sensor harness connector.

Is the inspection result normal?

YES >> GO TO 4.

NO >> Repair installation or replace wheel sensor.

- Front wheel sensor: Refer to [BRC-365, "FRONT WHEEL SENSOR : Removal and Installation"](#).
- Rear wheel sensor: Refer to [BRC-367, "REAR WHEEL SENSOR : Removal and Installation"](#).

4. CHECK SENSOR ROTOR

Check that there is no looseness, damage or foreign material on sensor rotor.

Is the inspection result normal?

YES >> GO TO 5.

NO >> Repair installation or replace sensor rotor.

- Front sensor rotor: Refer to [BRC-369, "FRONT SENSOR ROTOR : Removal and Installation - Front Sensor Rotor"](#).
- Rear sensor rotor: Refer to [BRC-369, "REAR SENSOR ROTOR : Removal and Installation - Rear Sensor Rotor"](#).

5. CHECK THAT WARNING LAMP TURNS OFF

Check that ABS warning lamp, brake warning lamp and VDC warning lamp turn OFF approximately 1 second after key switch is turned ON and stay in OFF status during driving.

CAUTION:

Brake warning lamp turns ON when parking brake is operated (parking brake switch is ON) or brake fluid is less than the specified level (brake fluid level switch is ON).

Is the inspection result normal?

YES >> Normal

NO >> GO TO 6.

6. PERFORM THE SELF DIAGNOSTIC RESULT

CONSULT

1. Turn the ignition switch OFF → ON.

CAUTION:

- Be sure to wait 10 seconds after turning ignition switch OFF or ON.

EXCESSIVE OPERATION FREQUENCY

[WITH ICC]

< SYMPTOM DIAGNOSIS >

- **Set the vehicle to READY/Start the engine.**
- 2. Repeat step 1 two or more times.
- 3. Select "Self Diagnostic Result" mode of "ABS".

Is any DTC detected?

- YES >> Check the DTC. Refer to [BRC-228, "DTC Index"](#).
- NO >> Inspection End.

UNEXPECTED BRAKE PEDAL REACTION

[WITH ICC]

< SYMPTOM DIAGNOSIS >

UNEXPECTED BRAKE PEDAL REACTION

Description

INFOID:000000012894649

A malfunction of brake pedal feel (height or other) is detected when brake pedal is depressed.

Diagnosis Procedure

INFOID:000000012894650

1.CHECK FRONT AND REAR AXLE

Check that there is no excessive looseness in front and rear axle.
Refer to [FAX-6. "Inspection"](#) (front) or [RAX-6. "Inspection"](#) (rear).

Is the inspection result normal?

YES >> GO TO 2.

NO >> Repair or replace error-detected parts.

2.CHECK DISC ROTOR

Check disc rotor runout.

- Front: Refer to [BR-11. "DISC BRAKE ROTOR : Inspection"](#).
- Rear: Refer to [BR-12. "DISC BRAKE ROTOR : Inspection"](#).

Is the inspection result normal?

YES >> GO TO 3.

NO >> Refinish the disc rotor.

3.CHECK BRAKE FLUID LEAKAGE

Check fluid leakage.

Refer to [BR-8. "Inspection"](#).

Is the inspection result normal?

YES >> GO TO 4.

NO >> Repair or replace error-detected parts.

4.CHECK BRAKE PEDAL

Check each item of brake pedal. Refer to [BR-7. "Inspection"](#).

Is the inspection result normal?

YES >> GO TO 5.

NO >> Adjust each item of brake pedal. Refer to [BR-13. "Adjustment"](#).

5.CHECK BRAKING FORCE

Check brake force using a brake tester.

Is the inspection result normal?

YES >> GO TO 6.

NO >> Check each component of brake system.

6.CHECK BRAKE PERFORMANCE

Disconnect ABS actuator and electric unit (control unit) connector so that ABS does not operate. Check that brake force is normal in this condition. Connect harness connectors after checking.

Is the inspection result normal?

YES >> Normal

NO >> Check each component of brake system.

A
B
C
D
E
BRC
G
H
I
J
K
L
M
N
O
P

THE BRAKING DISTANCE IS LONG

[WITH ICC]

< SYMPTOM DIAGNOSIS >

THE BRAKING DISTANCE IS LONG

Description

INFOID:000000012894651

Brake stopping distance is long when ABS function is operated.

Diagnosis Procedure

INFOID:000000012894652

CAUTION:

Brake stopping distance on a slippery road like a rough road, gravel road or snowy road may become longer when ABS is operated than when ABS is not operated.

1.CHECK BRAKING FORCE

Check brake force using a brake tester.

Is the inspection result normal?

YES >> GO TO 2.

NO >> Check each component of brake system.

2.CHECK BRAKE PERFORMANCE

Disconnect ABS actuator and electric unit (control unit) connector so that ABS does not operate. Check brake stopping distance in this condition. Connect harness connectors after checking.

Is the inspection result normal?

YES >> Normal

NO >> Check each component of brake system.

DOES NOT OPERATE

< SYMPTOM DIAGNOSIS >

[WITH ICC]

DOES NOT OPERATE

Description

INFOID:0000000012894653

VDC function, TCS function, ABS function, EBD function, brake assist function or hill start assist function does not operate.

Diagnosis Procedure

INFOID:0000000012894654

CAUTION:

- VDC function, TCS function, ABS function, EBD function, brake assist function and hill start assist function never operate when the vehicle speed is 10 km/h (6.2 MPH) or less. However, TCS function, brake limited slip differential (BLSD) function and hill start assist function operate when the vehicle speed is 0 km/h (0 MPH) (the vehicle is in stop status).
- VDC function and TCS function never operate when VDC OFF switch is operated (when VDC OFF indicator lamp turns ON).

1. CHECK ABS WARNING LAMP

Check that ABS warning lamp, brake warning lamp and VDC warning lamp turn ON and turn OFF approximately 1 second after key switch is turned ON. Check that ABS warning lamp, brake warning lamp and VDC warning lamp stay in OFF status during driving.

CAUTION:

Brake warning lamp turns ON when parking brake is operated (parking brake switch is ON) or brake fluid is less than the specified level (brake fluid level switch is ON).

Is the inspection result normal?

- YES >> Normal
NO >> GO TO 2.

2. PERFORM SELF DIAGNOSTIC RESULT

CONSULT

1. Turn the ignition switch OFF → ON.

CAUTION:

- Be sure to wait 10 seconds after turning ignition switch OFF or ON.
- Start the engine.

2. Repeat step 1 two or more times.
3. Perform "Self Diagnostic Result" mode of "ABS" with CONSULT.

Is any DTC detected?

- YES >> Check the DTC. Refer to [BRC-228, "DTC Index"](#).
NO >> Inspection End.

A
B
C
D
E
BRC
G
H
I
J
K
L
M
N
O
P

BRAKE PEDAL VIBRATION OR OPERATION SOUND OCCURS

< SYMPTOM DIAGNOSIS >

[WITH ICC]

BRAKE PEDAL VIBRATION OR OPERATION SOUND OCCURS

Description

INFOID:000000012894655

- Brake pedal vibrates and motor sound from ABS actuator and electric unit (control unit) occurs when the engine starts.
- Brake pedal vibrates during braking.

CAUTION:

Vibration may be felt when brake pedal is lightly depressed (just placing a foot on it) in the following conditions. This is normal.

- When shifting gears
- When driving on slippery road
- During cornering at high speeds
- When passing over bumps or grooves [Approx. 50 mm (1.97 in) or more]
- When pulling away just after starting engine [at approx. 10 km/h (6.2 MPH) or higher]

Diagnosis Procedure

INFOID:000000012894656

1. SYMPTOM CHECK 1

Check that there are pedal vibrations when the engine is started.

Do vibrations occur?

- YES >> GO TO 2.
- NO >> Check brake pedal. Refer to [BR-13. "Adjustment"](#).

2. SYMPTOM CHECK 2

Check that motor sound from ABS actuator and electric unit occurs when the engine starts.

Does the operation sound occur?

- YES >> GO TO 3.
- NO >> Perform "Self Diagnostic Result" mode of "ABS" with CONSULT.

3. SYMPTOM CHECK 3

Check symptoms when electrical component (headlamps, etc.) switches are operated.

Does the symptom occur?

- YES >> Check that radio (including wiring), antenna and antenna lead-in wires are not located near ABS actuator and electric unit (control unit). Move them if they are located near ABS actuator and electric unit (control unit).
- NO >> GO TO 4.

4. PERFORM SELF DIAGNOSTIC RESULT

CONSULT

1. Turn the ignition switch OFF → ON.

CAUTION:

- Be sure to wait 10 seconds after turning ignition switch OFF or ON.
 - Start the engine.
2. Repeat step 1 two or more times.
 3. Perform "Self Diagnostic Result" mode of "ABS".

Is any DTC detected?

- YES >> Check the DTC. Refer to [BRC-228. "DTC Index"](#).
- NO >> Inspection End.

VEHICLE JERKS DURING

Description

INFOID:000000012894657

The vehicle jerks when VDC function, TCS function, ABS function, EBD function, brake assist function or hill start assist function operates.

Diagnosis Procedure

INFOID:000000012894658

1. CHECK SYMPTOM

Check that the vehicle jerks when VDC function, TCS function, ABS function, EBD function, brake assist function or hill start assist function operates.

Is the inspection result normal?

- YES >> Normal
- NO >> GO TO 2.

2. PERFORM THE SELF DIAGNOSTIC RESULT

Ⓜ With CONSULT

1. Turn the ignition switch OFF → ON.

CAUTION:

- Be sure to wait 10 seconds after turning ignition switch OFF or ON.
- Start the engine.

2. Repeat step 1 two or more times.
3. Perform "Self Diagnostic Result" mode of "ABS".

Is any DTC detected?

- YES >> Check the DTC. Refer to [BRC-228, "DTC Index"](#).
- NO >> GO TO 3.

3. CHECK CONNECTOR

1. Turn the ignition switch OFF.
2. Disconnect ABS actuator and electric unit (control unit) harness connector.
3. Check connector terminal for deformation, disconnection and looseness.

Is the inspection result normal?

- YES >> GO TO 4.
- NO >> Poor connection of connector terminal. Repair or replace connector terminal.

4. PERFORM THE SELF DIAGNOSTIC RESULT

Ⓜ CONSULT

1. Connect harness connector.
 2. Turn the ignition switch OFF → ON.
- CAUTION:**
- Be sure to wait 10 seconds after turning ignition switch OFF or ON.
 - Start the engine.
3. Repeat step 2 two or more times.
 4. Perform "Self Diagnostic Result" mode of "ABS".

Is any DTC detected?

- YES >> Check the DTC. Refer to [BRC-228, "DTC Index"](#).
- NO >> GO TO 5.

5. PERFORM THE SELF DIAGNOSTIC RESULT

Ⓜ CONSULT

Perform "Self Diagnostic Result" mode of "ENGINE" and "TRANSMISSION".

Is any DTC detected?

- YES >> Check the DTC.
- NO >> Replace ABS actuator and electric unit (control unit). Refer to [BRC-370, "Removal and Installation"](#).

NORMAL OPERATING CONDITION

< SYMPTOM DIAGNOSIS >

[WITH ICC]

NORMAL OPERATING CONDITION

Description

INFOID:000000012894659

Symptom	Result
Brake pedal slightly vibrates and operation sound (motor sound and sound from suspension) occurs when VDC function, TCS function, ABS function, EBD function, brake assist function, hill start assist function operates.	This is not a malfunction, because it is caused by VDC function, TCS function, ABS function, EBD function, brake assist function, hill start assist function that are normally operated.
Brake stopping distance may become longer than models without ABS function depending on the road conditions when ABS function is operated on a slippery road, rough road, gravel road or snowy road.	
Brake pedal vibrates and operation sound occurs during sudden acceleration and cornering when VDC function, TCS function, brake assist function or brake force distribution function is operated.	
Brake pedal vibrates and motor sound from the engine room occurs when the engine starts or the vehicle starts just after starting the engine.	This is not a malfunction, because it is caused by operation check of ABS actuator and electric unit (control unit).
Acceleration may feel insufficient depending on the road conditions.	This is not a malfunction, because it is caused by TCS function that puts the highest priority to obtain the optimum traction (stability).
TCS function may operate momentarily while driving on a road where friction coefficient varies or when downshifting or fully depressing accelerator pedal.	
ABS warning lamp and VDC OFF indicator lamp may turn ON when the vehicle is on a rotating turntable or is given a strong shaking or large vibrations on a ship while the engine is running.	In this case, restart the engine on a normal road. If the normal condition is restored, there is no malfunction. In that case, erase "ABS" self-diagnosis result memory with CONSULT.
VDC warning lamp may turn ON and VDC function, TCS function, brake assist function, and brake force distribution function may not normally operate when driving on a special road the is extremely slanted (bank in a circuit course).	
A malfunction in yaw rate/side/decel G sensor system may be detected when the vehicle sharply turns during a spin turn, acceleration turn or drift driving while VDC function TCS function are OFF (VDC OFF switch is pressed and VDC OFF indicator lamp is in ON status).	
The vehicle speed does not increase, when the accelerator pedal is depressed while the vehicle is on a 2-wheel chassis dynamometer for speedometer check.	This is normal. (When checking the vehicle on a chassis dynamometer, operate VDC OFF switch so that TCS function is OFF.)

WHEEL SENSOR

< REMOVAL AND INSTALLATION >

[WITH ICC]

REMOVAL AND INSTALLATION

WHEEL SENSOR

FRONT WHEEL SENSOR

FRONT WHEEL SENSOR : Exploded View

INFOID:000000012894660

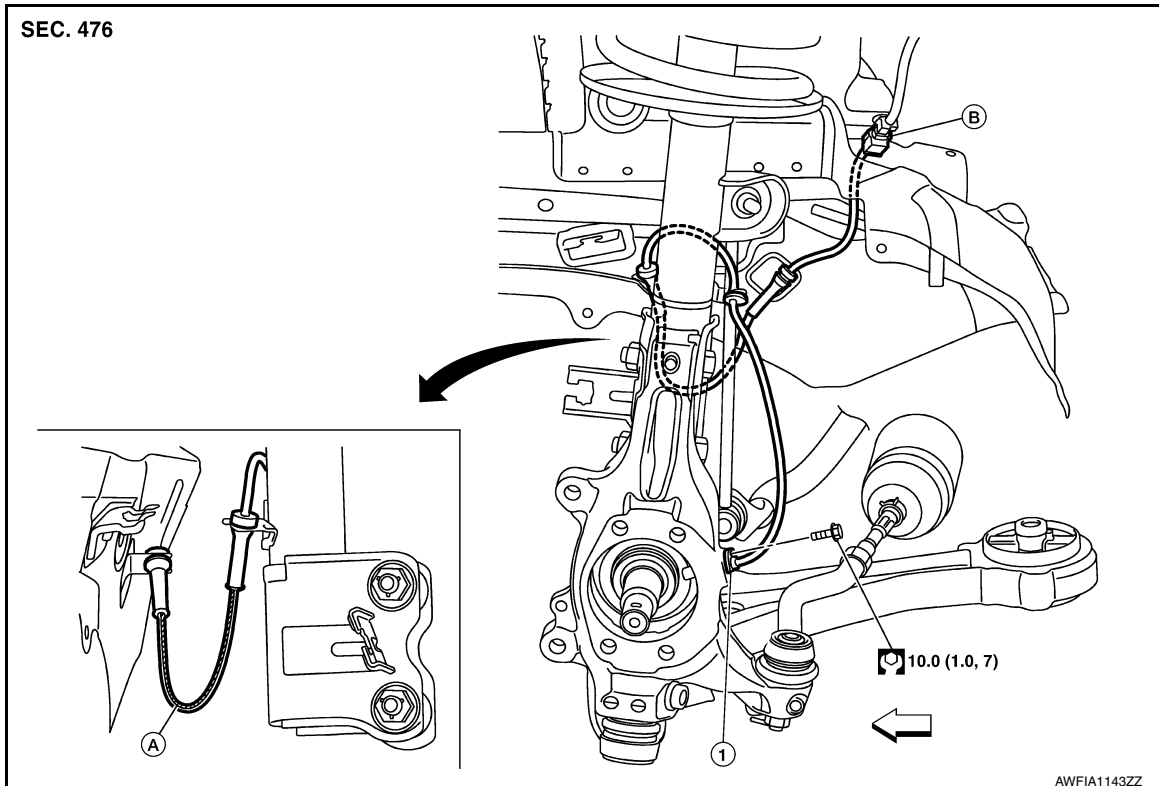

1. Front wheel sensor

A. Color line (slant line)

B. Front wheel sensor harness connector

← Front

FRONT WHEEL SENSOR : Removal and Installation

INFOID:000000012894661

CAUTION:

Do not damage the front wheel sensor or sensor rotor.

REMOVAL

1. Remove front wheel and tire using power tool. Refer to [WT-63, "Balancing Wheels"](#).
2. Remove fender protector retaining pin to gain access to wheel sensor harness connector.
3. Disconnect harness connector from front wheel sensor.
4. Remove front wheel sensor bolt (A) from wheel hub and bearing.

CAUTION:

Pull out the front wheel sensor being careful to turn it as little as possible. Do not pull on the front wheel sensor harness.

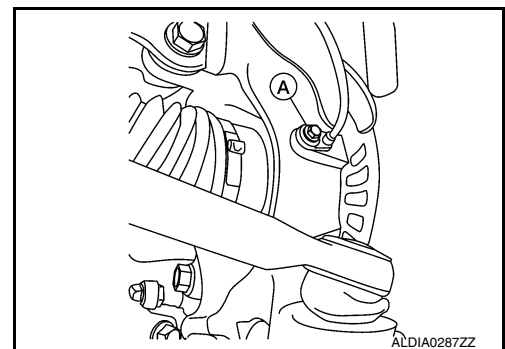

WHEEL SENSOR

[WITH ICC]

< REMOVAL AND INSTALLATION >

5. Remove front wheel sensor from strut bracket.
6. Remove front wheel sensor from steering knuckle.

CAUTION:

Pull out the front wheel sensor being careful to turn it as little as possible. Do not pull on the front wheel sensor harness.

INSTALLATION

Installation is in the reverse order of removal.

CAUTION:

- Before installing, make sure there is no foreign material, such as iron fragments, adhered to the pick-up part of the front wheel sensor.
- When installing, make sure there is no foreign material, such as iron fragments, on and in the hole in the steering knuckle for the front wheel sensor. Make sure no foreign material has been caught in the sensor rotor. Remove any foreign material and clean the mount.
- Do not twist front wheel sensor harness when installing front wheel sensor. Check that grommet (2) is fully inserted to bracket (1). Check that front wheel sensor harness is not twisted after installation.

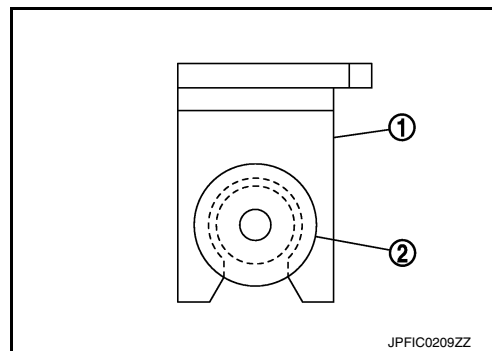

REAR WHEEL SENSOR

REAR WHEEL SENSOR : Exploded View

INFOID:000000012894662

RH Side

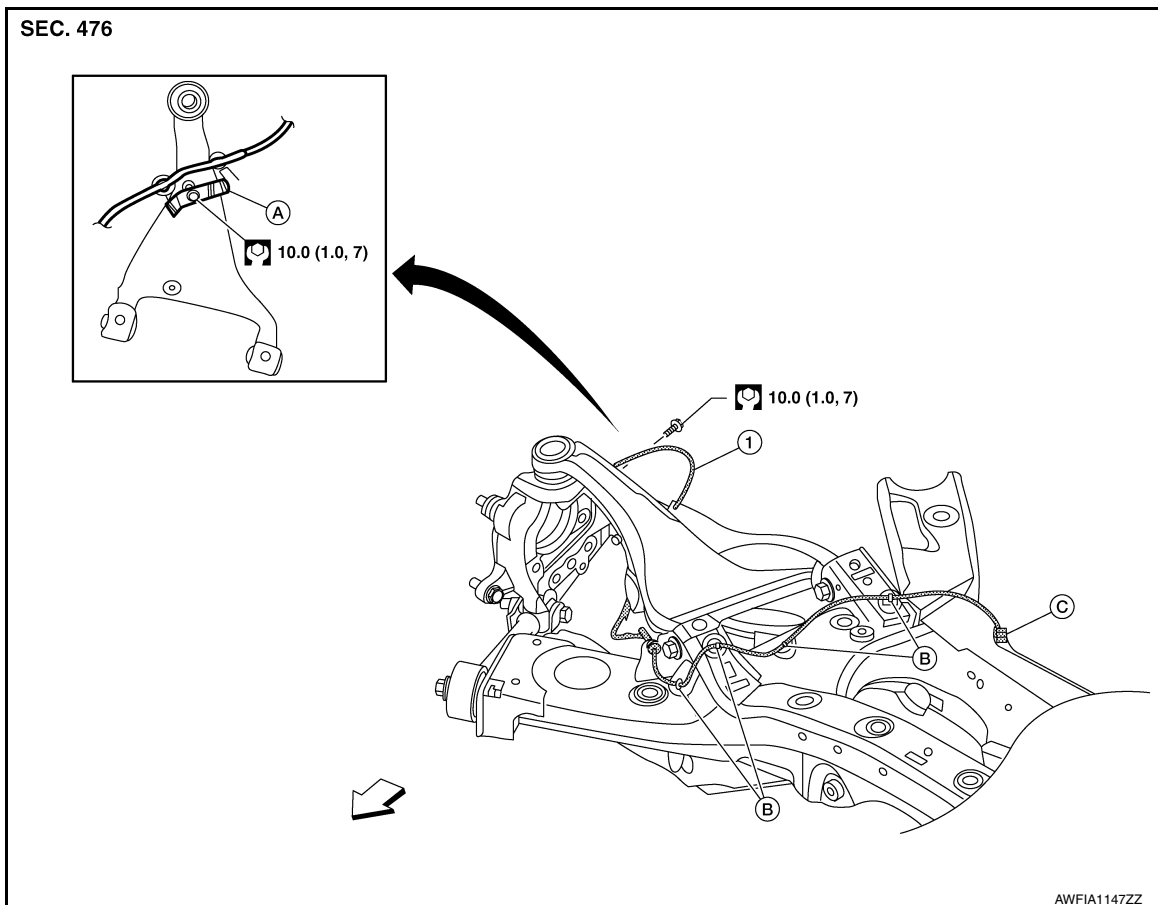

WHEEL SENSOR

< REMOVAL AND INSTALLATION >

[WITH ICC]

- 1. Rear wheel sensor
- A. Rear wheel sensor bracket
- B. Clip
- C. Rear wheel sensor connector
- ⇐ Front

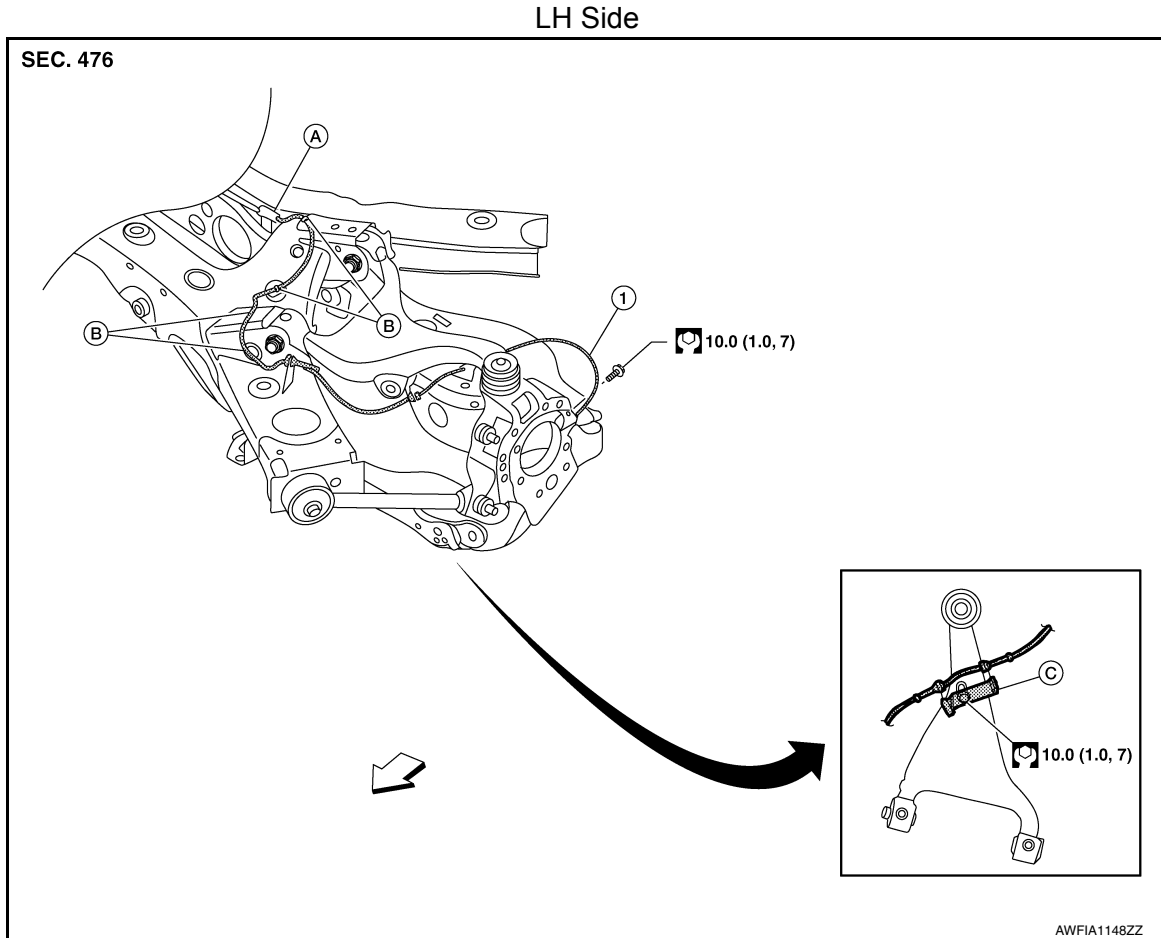

- 1. Rear wheel sensor
- A. Rear wheel sensor connector
- B. Clip
- C. Rear wheel sensor bracket
- ⇐ Front

REAR WHEEL SENSOR : Removal and Installation

INFOID:000000012894663

CAUTION:

Do not damage rear wheel sensor or sensor rotor.

REMOVAL

1. Remove rear under cover. Refer to [EXT-40. "REAR UNDER COVER : Removal and Installation"](#).
2. Remove rear wheel and tire using power tool. Refer to [WT-66. "Removal and Installation"](#).
3. Remove rear wheel sensor bolt (1).

CAUTION:

Pull out the rear wheel sensor being careful to turn it as little as possible. Do not pull on the rear wheel sensor harness.

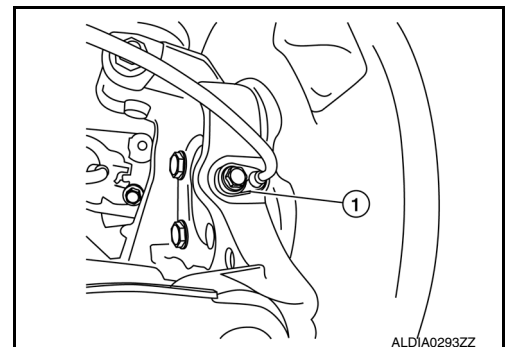

4. Disconnect harness connector from rear wheel sensor.

WHEEL SENSOR

[WITH ICC]

< REMOVAL AND INSTALLATION >

5. Remove rear wheel sensor from sensor brackets.
6. Remove rear wheel sensor from rear knuckle.

CAUTION:

Pull out the rear wheel sensor being careful to turn it as little as possible. Do not pull on the rear wheel sensor harness.

INSTALLATION

Installation is in the reverse order of removal.

CAUTION:

- Before installing, make sure there is no foreign material, such as iron fragments, adhered to the pick-up part of the rear wheel sensor
- When installing, make sure there is no foreign material, such as iron fragments, on and in the hole in the rear knuckle for the rear wheel sensor. Make sure no foreign material has been caught in the sensor rotor. Remove any foreign material and clean the mount.
- Do not twist rear wheel sensor harness when installing rear wheel sensor. Check that grommet (2) is fully inserted to bracket (1). Check that rear wheel sensor harness is not twisted after installation.

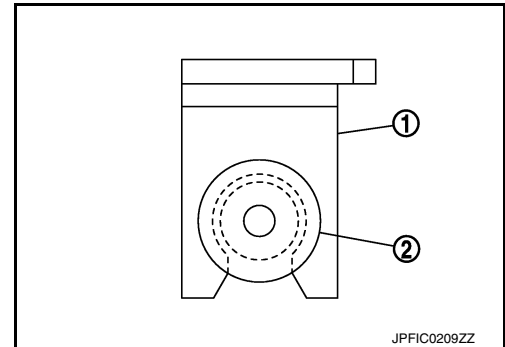

SENSOR ROTOR

< REMOVAL AND INSTALLATION >

[WITH ICC]

SENSOR ROTOR

FRONT SENSOR ROTOR

FRONT SENSOR ROTOR : Removal and Installation - Front Sensor Rotor INFOID:0000000012894664

The front wheel sensor rotor is an integral part of the wheel hub and bearing and cannot be disassembled. Refer to [FAX-8. "Removal and Installation"](#).

REAR SENSOR ROTOR

REAR SENSOR ROTOR : Removal and Installation - Rear Sensor Rotor INFOID:0000000012894665

The rear wheel sensor rotor is an integral part of the wheel hub and bearing and cannot be disassembled. Refer to [RAX-8. "Removal and Installation"](#).

A
B
C
D
E
G
H
I
J
K
L
M
N
O
P

BRC

ABS ACTUATOR AND ELECTRIC UNIT (CONTROL UNIT)

< REMOVAL AND INSTALLATION >

[WITH ICC]

ABS ACTUATOR AND ELECTRIC UNIT (CONTROL UNIT)

Exploded View

INFOID:000000012894666

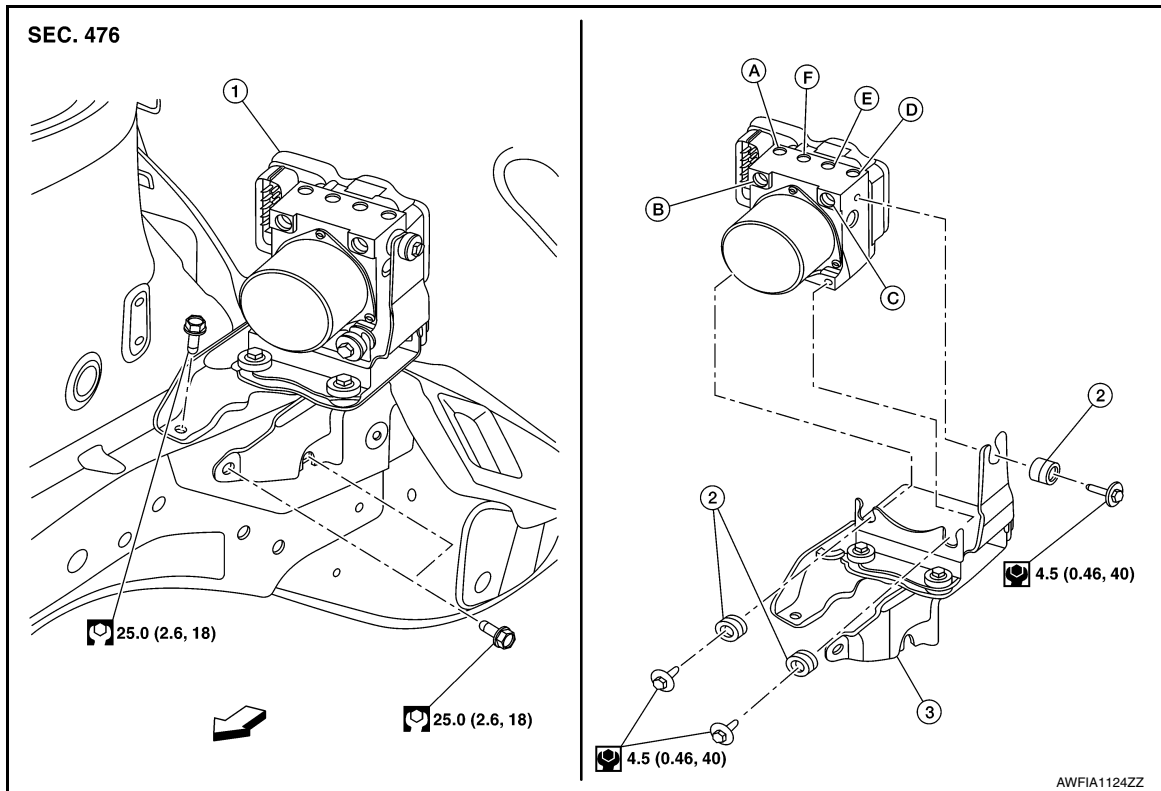

- | | | |
|--|--|--------------------------------------|
| 1. ABS actuator and electric unit (control unit) | 2. Bushings | 3. Bracket |
| A. To front RH brake caliper | B. From master cylinder secondary side | C. From master cylinder primary side |
| D. To front LH brake caliper | E. To rear RH brake caliper | F. To rear LH brake caliper |

↶ Front

Removal and Installation

INFOID:000000012894667

REMOVAL

CAUTION:

- To remove brake tube, use a flare nut wrench to prevent flare nuts and brake tube from being damaged.
- Do not remove actuator by holding harness.

NOTE:

- Before replacing ABS actuator and electric unit (control unit), use the CONSULT to check the ABS actuator and electric unit (control unit) type ID. Refer to [BRC-251, "Work Procedure"](#).
 - When removing components such as hoses, tubes/lines, etc., cap or plug openings to prevent fluid from spilling.
1. Disconnect negative battery terminal. Refer to [PG-112, "Exploded View"](#).
 2. Remove cowl top cover. Refer to [EXT-34, "Removal and Installation - Cowl Top Cover"](#).
 3. Remove cowl top extension. Refer to [EXT-35, "Removal and Installation - Cowl Top Extension"](#).
 4. Separate brake tubes from ABS actuator and electric unit (control unit). Refer to [BR-22, "FRONT : Exploded View"](#).
 5. Disconnect harness connector from ABS actuator and electric unit (control unit).
 6. Remove ABS actuator and electric unit (control unit) bracket bolts and bushings.
 7. Remove ABS actuator and electric unit (control unit) from vehicle.

INSTALLATION

ABS ACTUATOR AND ELECTRIC UNIT (CONTROL UNIT)

< REMOVAL AND INSTALLATION >

[WITH ICC]

CAUTION:

Be sure to perform "Manual Configuration" when replacing ABS actuator and electric unit (control unit). Refer to [BRC-251, "Work Procedure"](#).

Installation is in the reverse order of removal.

- After work is completed, bleed air from brake tube. Refer to [BR-14, "Bleeding Brake System"](#).
- Adjust the neutral position of steering angle sensor. Refer to [BRC-62, "Work Procedure"](#).
- Perform calibration of the decel G sensor. Refer to [BRC-64, "Work Procedure"](#).

CAUTION:

- To install, use flare nut crowfoot and torque wrench.
- Replace the ABS actuator if it has been dropped or sustained an impact.
- Do not install actuator by holding harness.
- After installing harness connector in the ABS actuator and electric unit (control unit), make sure connector is securely locked.

A
B
C
D
E
G
H
I
J
K
L
M
N
O
P

BRC

VDC OFF SWITCH

< REMOVAL AND INSTALLATION >

[WITH ICC]

VDC OFF SWITCH

Exploded View

INFOID:000000012894668

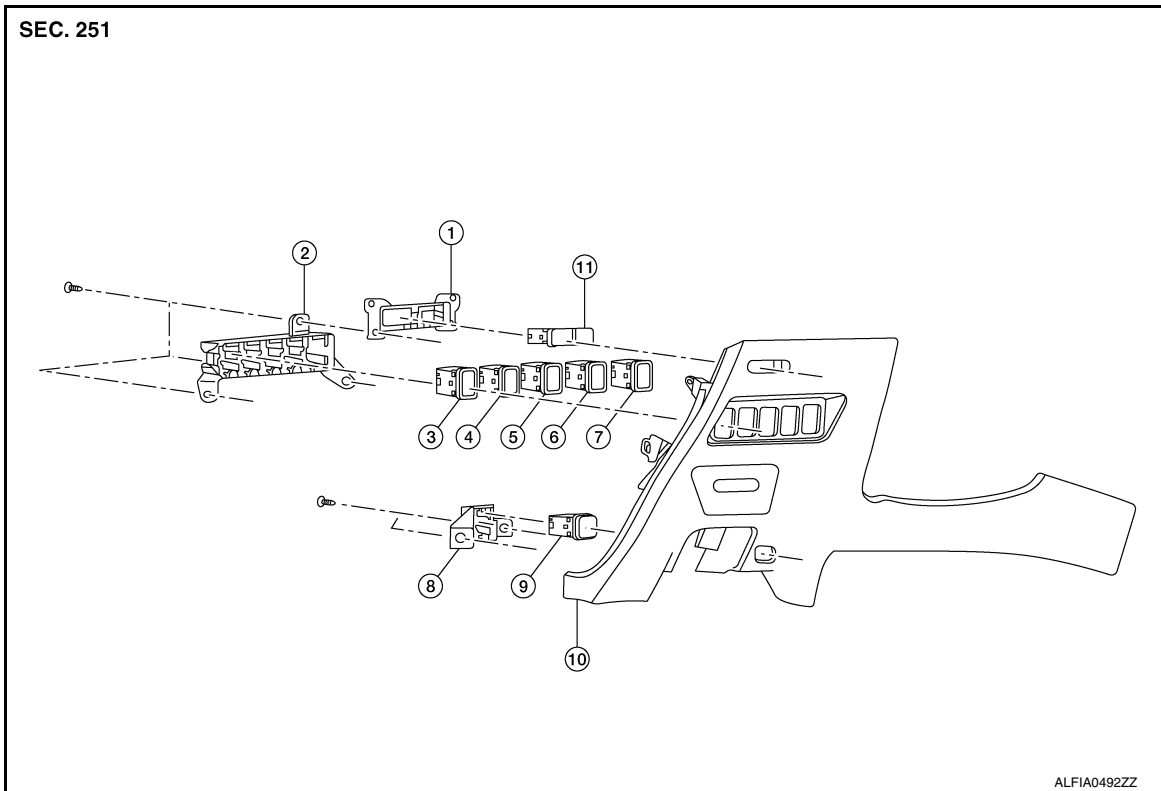

- | | | |
|-------------------------------|---------------------------------|---------------------------------|
| 1. Upper switch carrier | 2. Middle switch carrier | 3. VDC OFF switch |
| 4. Mask | 5. Automatic back door switch | 6. Heated steering wheel switch |
| 7. Mask | 8. Lower switch carrier | 9. Front power return switch |
| 10. Instrument lower panel LH | 11. Illumination control switch | |

Removal and Installation

INFOID:000000012894669

REMOVAL

1. Remove instrument lower panel LH. Refer to [IP-24. "Removal and Installation"](#).
2. Remove screws and middle switch carrier from instrument lower panel LH.
3. Release pawls using suitable tool and remove VDC OFF switch from the middle switch carrier.

○: Pawl

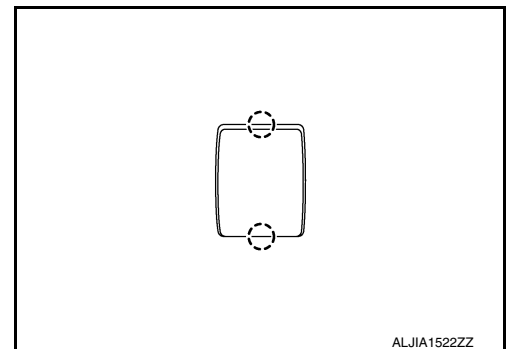

INSTALLATION

Installation is in the reverse order of removal.

STEERING ANGLE SENSOR

< REMOVAL AND INSTALLATION >

[WITH ICC]

STEERING ANGLE SENSOR

Exploded View

INFOID:000000012894670

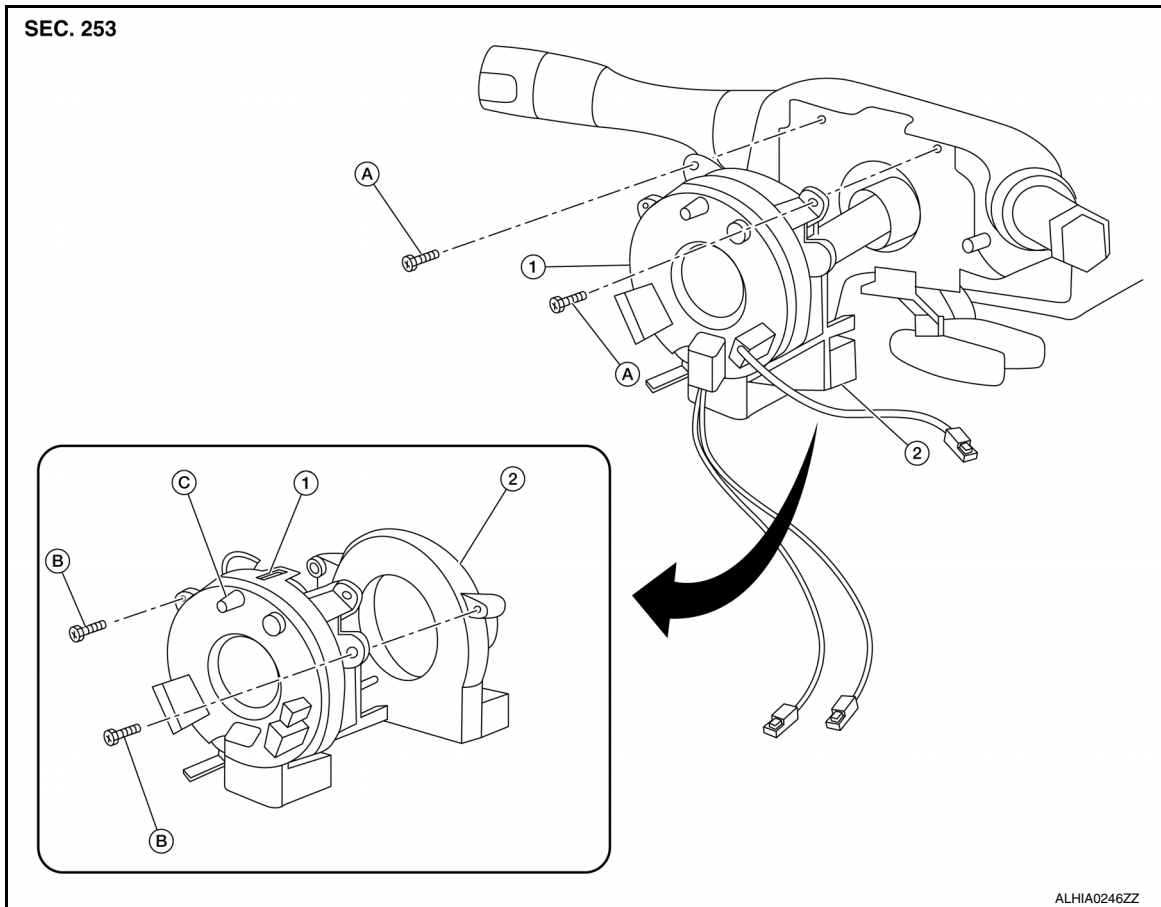

- | | | |
|---------------------------------|--------------------------|------------------------|
| 1. Spiral cable | 2. Steering angle sensor | A. Spiral cable screws |
| B. Steering angle sensor screws | C. Locating pin | |

Removal and Installation

INFOID:000000012894671

To remove and install the steering angle sensor, remove and install the spiral cable. Refer to [SR-15, "Removal and Installation"](#).