

A
FL
C
D
E
F
G
H
I
J
K
L
M
N
O
P

SECTION **FL**

FUEL SYSTEM

CONTENTS

PRECAUTION	2	AWD	14
PRECAUTIONS	2	AWD : Exploded View	15
Precaution for Supplemental Restraint System (SRS) "AIR BAG" and "SEAT BELT PRE-TENSIONER"	2	AWD : Removal and Installation	15
General Precaution	2	AWD : Inspection	18
PREPARATION	3	EVAP CANISTER	19
PREPARATION	3	Exploded View	19
Special Service Tool	3	Removal and Installation	19
Commercial Service Tool	3	Inspection	20
PERIODIC MAINTENANCE	4	EVAP CANISTER FILTER	21
FUEL SYSTEM	4	Exploded View	21
Inspection	4	Removal and Installation	21
Quick Connector	4	EVAP CANISTER VENT CONTROL VALVE ...	22
REMOVAL AND INSTALLATION	5	Exploded View	22
FUEL LEVEL SENSOR UNIT, FUEL FILTER AND FUEL PUMP ASSEMBLY	5	Removal and Installation	22
Exploded View	5	EVAP CONTROL SYSTEM PRESSURE SENSOR	23
Removal and Installation	5	Exploded View	23
Inspection	10	Removal and Installation	23
FUEL TANK	11	DISASSEMBLY AND ASSEMBLY	24
FWD	11	FUEL LEVEL SENSOR UNIT	24
FWD : Exploded View	11	Exploded View	24
FWD : Removal and Installation	11	Disassembly and Assembly	24
FWD : Inspection	14	SERVICE DATA AND SPECIFICATIONS (SDS)	26
		SERVICE DATA AND SPECIFICATIONS (SDS)	26
		Fuel Tank	26

PRECAUTIONS

< PRECAUTION >

PRECAUTION

PRECAUTIONS

Precaution for Supplemental Restraint System (SRS) "AIR BAG" and "SEAT BELT PRE-TENSIONER"

INFOID:000000012891578

The Supplemental Restraint System such as "AIR BAG" and "SEAT BELT PRE-TENSIONER", used along with a front seat belt, helps to reduce the risk or severity of injury to the driver and front passenger for certain types of collision. Information necessary to service the system safely is included in the SR and SB section of this Service Manual.

WARNING:

- To avoid rendering the SRS inoperative, which could increase the risk of personal injury or death in the event of a collision which would result in air bag inflation, it is recommended that all maintenance and repair be performed by an authorized NISSAN/INFINITI dealer.
- Improper repair, including incorrect removal and installation of the SRS, can lead to personal injury caused by unintentional activation of the system. For removal of Spiral Cable and Air Bag Module, see the SR section.
- Do not use electrical test equipment on any circuit related to the SRS unless instructed to in this Service Manual. SRS wiring harnesses can be identified by yellow and/or orange harnesses or harness connectors.

PRECAUTIONS WHEN USING POWER TOOLS (AIR OR ELECTRIC) AND HAMMERS

WARNING:

- When working near the Air Bag Diagnosis Sensor Unit or other Air Bag System sensors with the Ignition ON or engine running, DO NOT use air or electric power tools or strike near the sensor(s) with a hammer. Heavy vibration could activate the sensor(s) and deploy the air bag(s), possibly causing serious injury.
- When using air or electric power tools or hammers, always switch the Ignition OFF, disconnect the battery or batteries, and wait at least three minutes before performing any service.

General Precaution

INFOID:000000012891579

WARNING:

When replacing fuel line parts, be sure to observe the following:

- Put a "CAUTION: FLAMMABLE" sign in the workshop.
- Be sure to work in a well ventilated area and furnish workshop with a CO₂ fire extinguisher.
- Do not smoke while servicing fuel system. Keep open flames and sparks away from the work area.

CAUTION:

- Use gasoline required by the regulations for octane number. Refer to [GI-27, "Fuel"](#).
- Before removing fuel line parts, perform the following procedures:
 - Put drained fuel in an explosion-proof container and put the lid on securely. Keep the container in safe area.
 - Release fuel pressure from the fuel lines. Refer to [EC-162, "Work Procedure"](#).
 - Disconnect the battery cable from the negative terminal.
- Always replace O-rings and clamps with new ones.
- Do not kink or twist tubes when they are being installed.
- Do not tighten hose clamps excessively to avoid damaging hoses.
- After installing tubes, check that there are no fuel leaks at connections in the following steps.
 - Apply fuel pressure to fuel lines by turning ignition switch "ON" (with engine stopped). Then check for fuel leaks at connections.
 - Start engine and rev it up and check for fuel leaks at connections.
- Use only a genuine NISSAN fuel filler cap as a replacement. If an incorrect fuel filler cap is used, the "MIL" may come on.

PREPARATION

< PREPARATION >

PREPARATION

PREPARATION

Special Service Tool

INFOID:0000000012891580

A

FL

The actual shape of the tools may differ from those illustrated here.

Tool number (TechMate No.) Tool name	Description
KV101207S0 (—) Unified fuel lock ring wrench	Removing and installing fuel tank lock ring
— (J-45747) Fuel tank lock ring wrench	

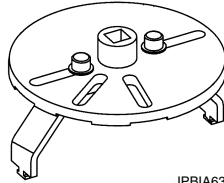

JPBIA6384ZZ

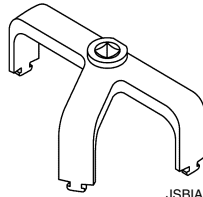

JSBIA1952ZZ

Commercial Service Tool

INFOID:0000000012891581

Tool name	Description
Power tool	Loosening nuts, screws and bolts



PIIB1407E

C

D

E

F

G

H

I

J

K

L

M

N

O

P

FUEL SYSTEM

< PERIODIC MAINTENANCE >

PERIODIC MAINTENANCE

FUEL SYSTEM

Inspection

INFOID:0000000012891582

Inspect fuel lines, fuel filler cap, and fuel tank for improper attachment, leaks, cracks, damage, loose connections, chafing or deterioration.

- (A) : Engine
- (B) : Fuel line
- (C) : Fuel tank

If necessary, repair or replace damaged parts.

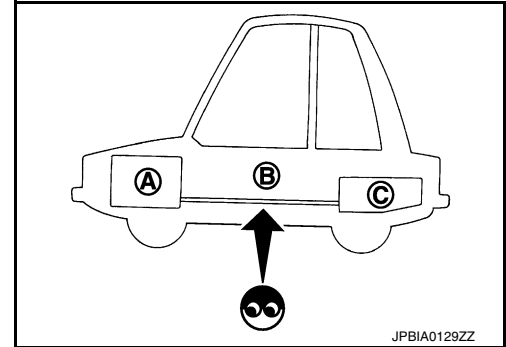

Quick Connector

INFOID:0000000012891583

CAUTION:

- After connecting fuel tube quick connectors, check that quick connectors are secure.
- Ensure that connector and resin tube never contact any adjacent parts.
- Quick connector (1) can be disconnected when the tabs (F) are depressed completely. Do not twist it more than necessary.

- (B) : Connection (cross-section)
- (D) : To under floor fuel line
- (E) : To fuel tank
- (G) : Disconnection

- Do not use any tools to disconnect quick connector.
- Keep resin tube (C) away from heat. Be especially careful when welding near the resin tube.
- Prevent acid liquid such as battery electrolyte, etc., from getting on resin tube.
- Do not bend or twist resin tube during installation and disconnection.
- Do not remove the remaining retainer (2) from hard tube (or the equivalent) (A) except when resin tube or retainer is replaced.
- When resin tube or hard tube (or the equivalent) is replaced, also replace retainer with new one.

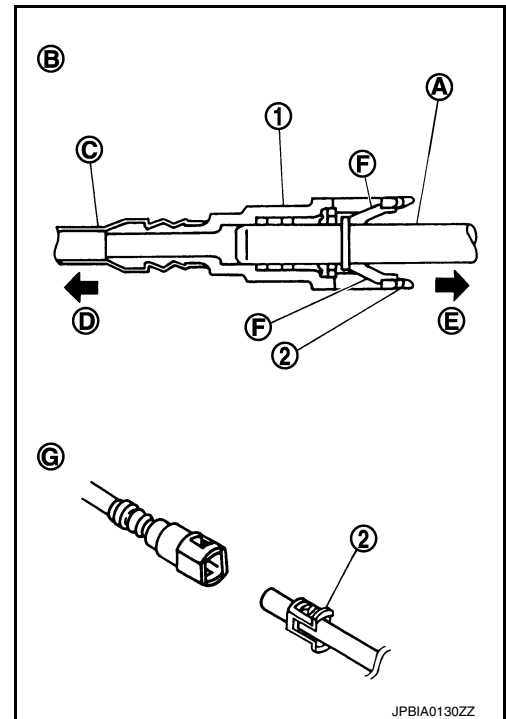

- To keep the connecting portions clean and to avoid damage and foreign materials, cover them completely with plastic bags (A) or something similar.

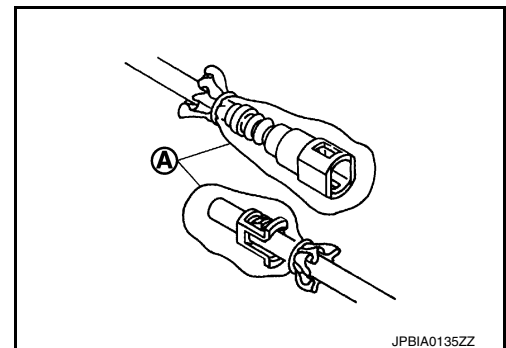

FUEL LEVEL SENSOR UNIT, FUEL FILTER AND FUEL PUMP ASSEMBLY

< REMOVAL AND INSTALLATION >

REMOVAL AND INSTALLATION

FUEL LEVEL SENSOR UNIT, FUEL FILTER AND FUEL PUMP ASSEMBLY

Exploded View

INFOID:0000000012891584

A

FL

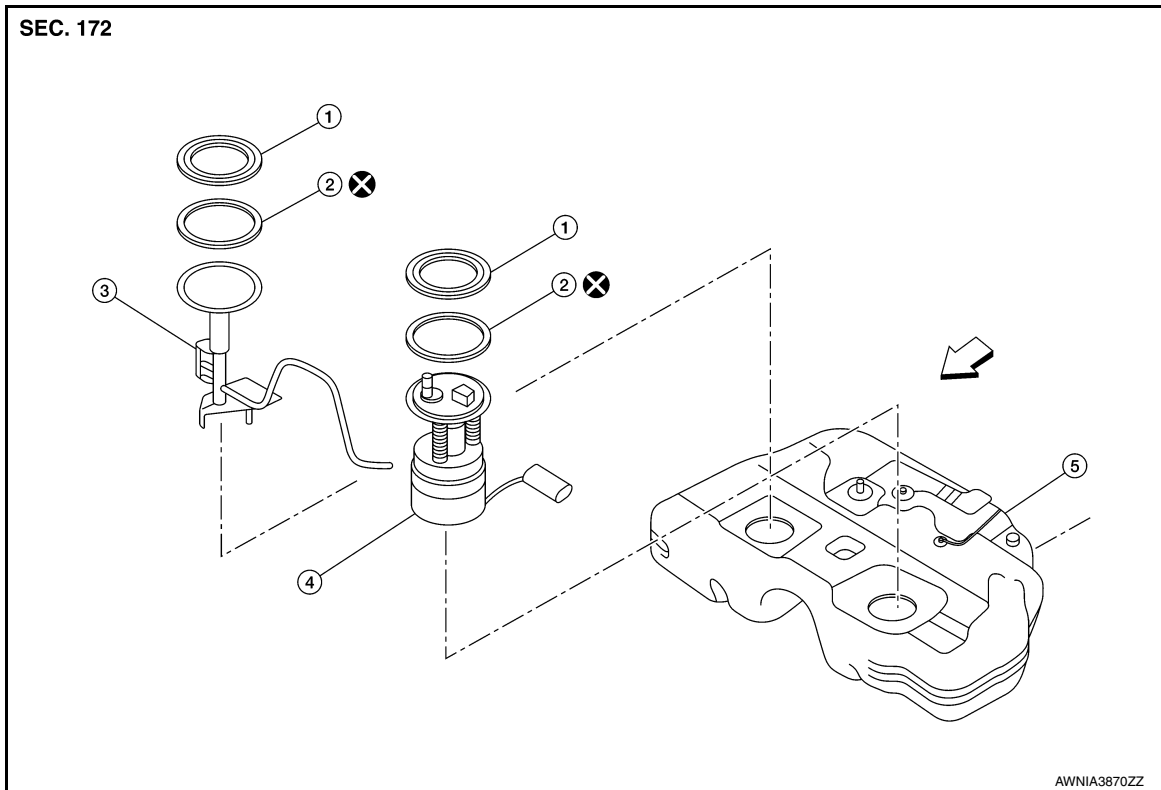

C

D

E

F

G

H

I

J

- 1. Lock ring
 - 2. O-ring
 - 3. Sub fuel level sensor assembly
 - 4. Fuel level sensor unit, fuel filter and fuel pump assembly
 - 5. Fuel tank
- ← Front

K

Removal and Installation

INFOID:0000000012891585

WARNING:

Be sure to read "General Precaution" before working on the fuel system. Refer to [FL-2, "General Precaution"](#).

CAUTION:

Do not remove or disassemble parts unless instructed as shown.

NOTE:

When removing components such as hoses, tubes/lines, etc., cap or plug openings to prevent fluid from spilling.

L

M

N

REMOVAL

Fuel Level Sensor Unit, Fuel Filter And Fuel Pump Assembly

O

P

FUEL LEVEL SENSOR UNIT, FUEL FILTER AND FUEL PUMP ASSEMBLY

< REMOVAL AND INSTALLATION >

1. Check the fuel level with the vehicle on a level surface. If the fuel gauge indicates more than the level as shown (1/2 full), drain the fuel from the fuel tank until the fuel gauge indicates a level at or below as shown (1/2 full).
 - In case the fuel pump does not operate, use the following procedure:
 - a. Insert fuel tubing of less than 25 mm (0.98 in) diameter into the fuel filler tube through the fuel filler opening to drain fuel from the fuel filler tube.
 - b. Disconnect the fuel filler hose from the fuel filler tube.
 - c. Insert fuel tubing into the fuel tank through the fuel filler hose to drain fuel from the fuel tank.
 - As a guide, the fuel level reaches or is less than the level on the fuel gauge as shown when approximately 27.5 ℓ (7-1/4 US gal, 6 Imp gal) of fuel is drained from a full fuel tank.
2. Release fuel pressure from fuel lines. Refer to [EC-162, "Work Procedure"](#).
3. Open fuel filler lid.
4. Open fuel filler cap and release the pressure inside the fuel tank.
5. Disconnect negative battery terminal. Refer to [PG-112, "Removal and Installation"](#).
6. Remove second row seat (LH). Refer to [SE-135, "Removal and Installation"](#).
7. Turn the four retainers 90 degrees to disengage the clips and remove the fuel pump inspection hole cover.

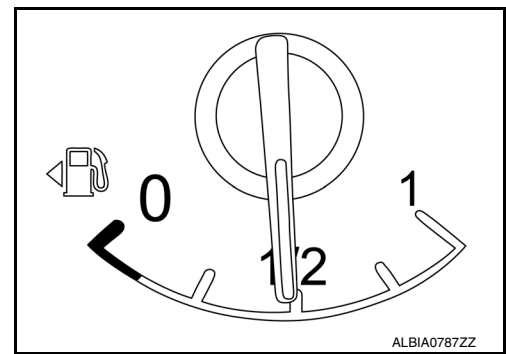

CAUTION:

Cover the immediate area surrounding the fuel pump inspection hole cover with plastic to avoid gasoline damage to carpet.

8. Disconnect harness connector (A) and quick connector (B).

↔ : Front

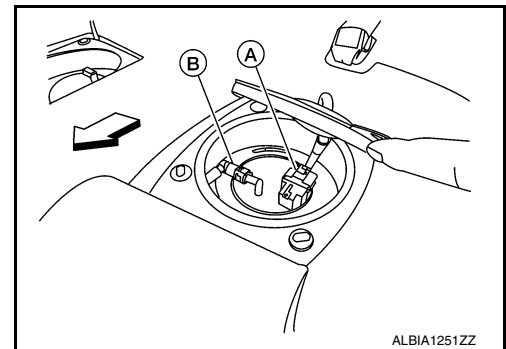

Disconnect quick connector as follows:

- Hold the sides of connector, press tabs and pull out fuel feed tube.

- (A) : Pull
(B) : Push in tabs

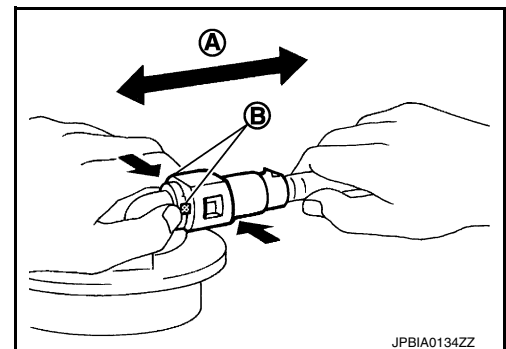

- If quick connector sticks to tube of main fuel level sensor unit, push and pull quick connectors several times until they start to move. Then disconnect them by pulling.

CAUTION:

FUEL LEVEL SENSOR UNIT, FUEL FILTER AND FUEL PUMP ASSEMBLY

< REMOVAL AND INSTALLATION >

- Quick connector (1) can be disconnected when the tabs (F) are depressed completely. Do not twist it more than necessary.

- (B) : Connection (cross-section)
- (D) : To under floor fuel line
- (E) : To fuel tank
- (G) : Disconnection

- Do not use any tools to disconnect quick connector.
- Keep resin tube (C) away from heat. Be especially careful when welding near the resin tube.
- Prevent acid liquid such as battery electrolyte, etc., from getting on resin tube.
- Do not bend or twist resin tube during installation and disconnection.
- Do not remove the remaining retainer (2) from hard tube (or the equivalent) (A) except when resin tube or retainer is replaced.
- When resin tube or hard tube (or the equivalent) is replaced, also replace retainer with new one.

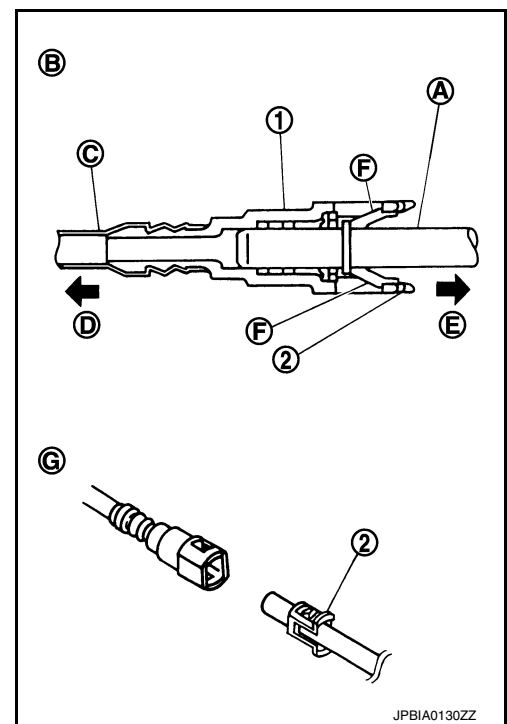

JPBIA0130ZZ

- To keep the connecting portions clean and to avoid damage and foreign materials, cover them completely with plastic bags (A) or something similar.

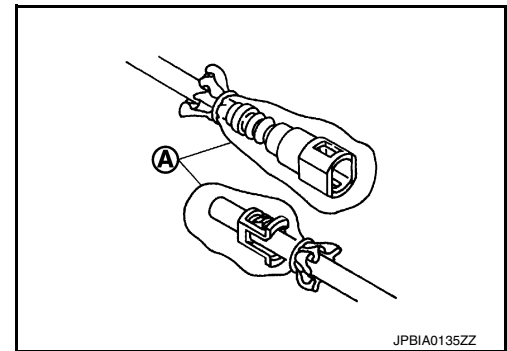

JPBIA0135ZZ

- Remove lock ring from fuel level sensor, fuel filter, and fuel pump assembly.
 - Remove the lock ring using Tool (A).

Tool number (A) : — (J-45747) (shown)
: KV101207S0 (—)

← : Front

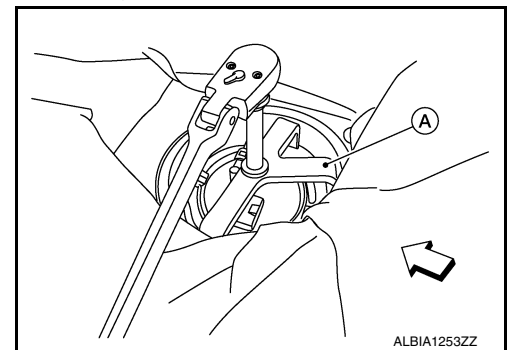

ALBIA1253ZZ

FUEL LEVEL SENSOR UNIT, FUEL FILTER AND FUEL PUMP ASSEMBLY

< REMOVAL AND INSTALLATION >

- Prior to removal, observe the alignment between the fuel level sensor, fuel filter, and fuel pump assembly tabs (A) and the matching marks (C) on the fuel tank as shown. This alignment is necessary for proper installation.

(B) : Retainer mounting pawl

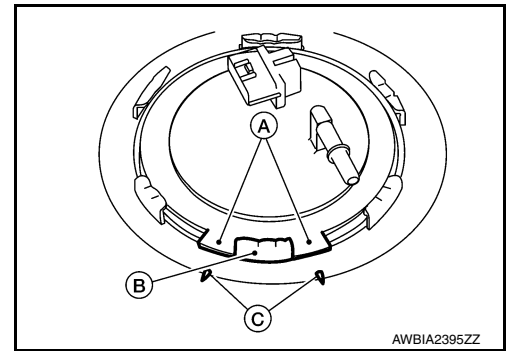

10. Raise fuel level sensor unit, fuel filter and fuel pump assembly (1), and disconnect fuel tube (A).

CAUTION:

- Do not bend float arm during removal.
- Do not pollute the inside with residue fuel. Draw out avoiding inclination by supporting with a cloth.
- Do not cause impacts such as by dropping when handling components.

NOTE:

Tie a gasoline-resistant rope to the tip of the tube. Draw and leave the rope to the fuel tank side so that the rope can be the guide for installation.

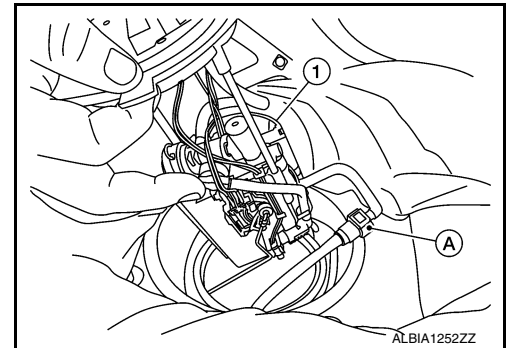

Sub Fuel Level Sensor Assembly

1. Remove fuel level sensor unit, fuel filter and fuel pump assembly.
2. Remove second row seat (RH). Refer to [SE-135, "Removal and Installation"](#).
3. Turn the four retainers 90 degrees to disengage the clips and remove the sub fuel sensor assembly inspection hole cover.

CAUTION:

Cover the immediate area surrounding the sub fuel sensor assembly inspection hole cover with plastic to avoid gasoline damage to carpet.

4. Disconnect the harness connector from the sub fuel sensor assembly.
5. Remove lock ring from sub fuel level assembly using Tool (A).

Tool number (A) : — (J-45747) (shown)
: KV101207S0 (—)

↔ : Front

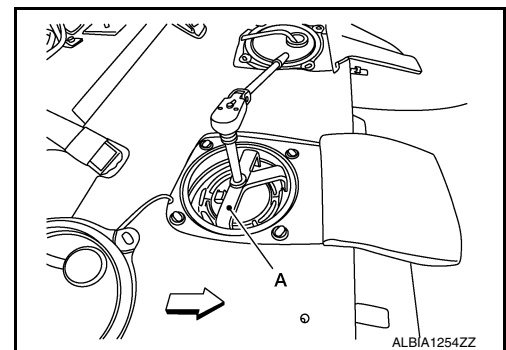

6. Remove sub fuel level sensor assembly (1).

CAUTION:

- Do not disassemble a fuel tube (2) from sub fuel sensor assembly.
- Do not bend float arm during removal.
- Do not pollute the inside with residue fuel. Draw out avoiding inclination by supporting with a cloth.
- Do not cause impacts such as by dropping when handling components.

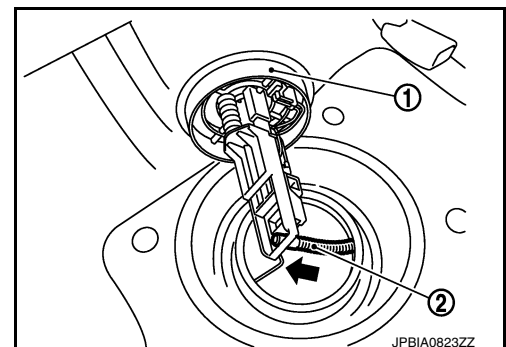

FUEL LEVEL SENSOR UNIT, FUEL FILTER AND FUEL PUMP ASSEMBLY

< REMOVAL AND INSTALLATION >

INSTALLATION

Installation is in the reverse order of removal.

- Install O-ring to fuel tank without any twists.

CAUTION:

Do not reuse O-ring.

- Using the rope left on the fuel tank side at removal, run the fuel tube inside the fuel tank to install the sub fuel level sensor assembly to the fuel tank.

CAUTION:

- **Do not bend float arm during installation.**

- **To install, fuel tube (1) must run to the front (↔) of the vehicle to avoid interference with the float arm (2) as shown.**

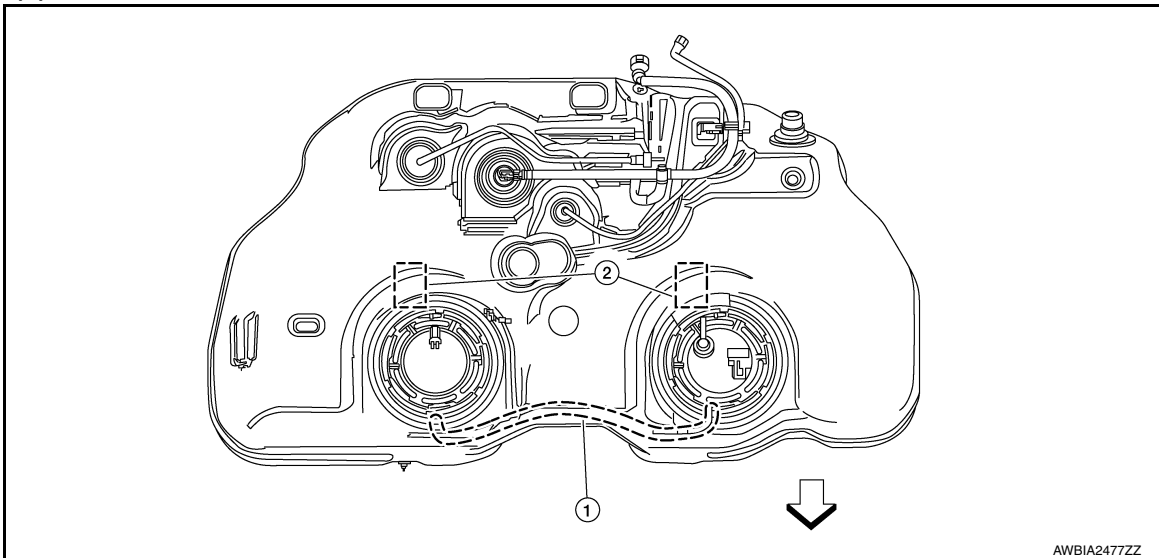

- Align the tabs (A) of the fuel level sensor unit, fuel filter and fuel pump assembly (1) as shown to alignment marks (B) on the fuel tank.

↔ : Front

NOTE:

Fuel level sensor unit, fuel filter and fuel pump assembly side of fuel tank shown.

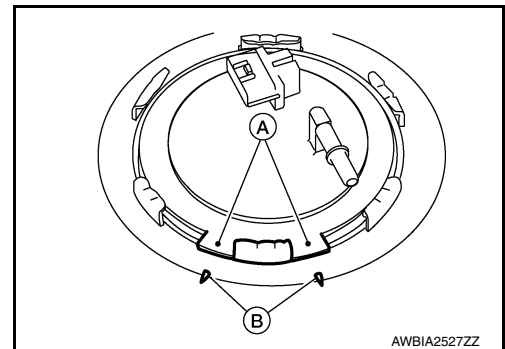

- Check the connection for damage or any foreign materials.
- Align the connector with the tube then insert the connector straight into the tube until a “click” sound is heard.
- After connecting, check that the connection is secured with the following procedures:
 - Visually confirm that the two tabs are connected to the connector.
 - Pull (A) the tube and the connector to check that they are securely connected.
- Before installing inspection hole cover, check that the connecting part has no fuel leaks. Refer to [FL-10. "Inspection"](#).
- Install inspection hole covers with the front mark (arrow) facing front.
- Lock clips by turning counterclockwise.

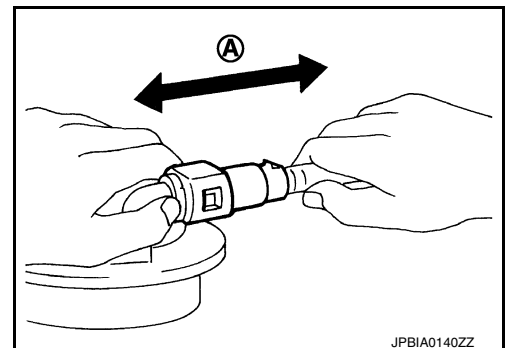

FUEL LEVEL SENSOR UNIT, FUEL FILTER AND FUEL PUMP ASSEMBLY

< REMOVAL AND INSTALLATION >

Inspection

INFOID:000000012891586

INSPECTION AFTER INSTALLATION

Use the following procedure to check for fuel leaks:

1. Turn ignition switch "ON" (with engine stopped) then check connections for leaks by applying fuel pressure to fuel piping.
2. Start engine. Then let it idle and check that there are no fuel leaks at the fuel system connections.

FUEL TANK

< REMOVAL AND INSTALLATION >

FUEL TANK

FWD

FWD : Exploded View

INFOID:000000012891587

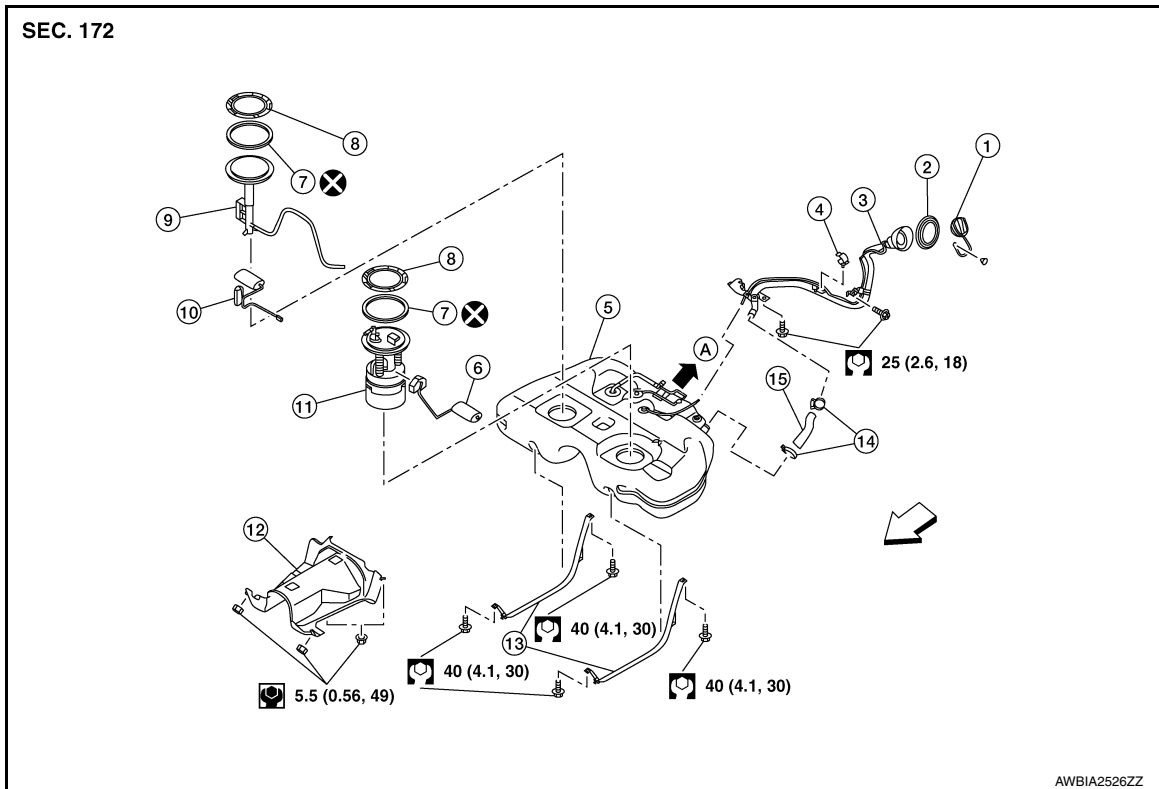

- | | | |
|---------------------------|----------------------------------------------------------------|----------------------------|
| 1. Fuel filler cap | 2. Grommet | 3. Fuel filler tube |
| 4. Clip | 5. Fuel tank | 6. Fuel level sensor |
| 7. O-ring | 8. Lock ring | 9. Sub fuel level assembly |
| 10. Sub fuel level sensor | 11. Fuel level sensor unit, fuel filter and fuel pump assembly | 12. Fuel tank protector |
| 13. Fuel tank strap | 14. Clamp | 15. Fuel filler hose |
| A. To EVAP canister | ↔ Front | |

FWD : Removal and Installation

INFOID:000000012891588

WARNING:

Be sure to read "General Precaution" when working on the fuel system. Refer to [FL-2. "General Precaution"](#).

NOTE:

When removing components such as hoses, tubes/lines, etc., cap or plug openings to prevent fluid from spilling.

REMOVAL

FUEL TANK

< REMOVAL AND INSTALLATION >

1. Check the fuel level with the vehicle on a level surface. If the fuel gauge indicates more than the level as shown (1/2 full), drain the fuel from the fuel tank until the fuel gauge indicates a level at or below as shown (1/2 full).

- In case the fuel pump does not operate, use the following procedure:

- a. Insert fuel tubing of less than 25 mm (0.98 in) diameter into the fuel filler tube through the fuel filler opening to drain fuel from the fuel filler tube.
- b. Disconnect the fuel filler hose from the fuel filler tube.
- c. Insert fuel tubing into the fuel tank through the fuel filler hose to drain fuel from the fuel tank.

- As a guide, the fuel level reaches or is less than the level on the fuel gauge as shown when approximately 27.5 ℓ (7-1/4 US gal, 6 Imp gal) of fuel are drained from a full fuel tank.

2. Release fuel pressure from fuel lines. Refer to [EC-162, "Work Procedure"](#).
3. Disconnect negative battery terminal. Refer to [PG-112, "Removal and Installation"](#).
4. Unscrew fuel filler cap to release the pressure inside the fuel tank.
5. Remove second row seat (LH\RH). Refer to [SE-135, "Removal and Installation"](#).
6. Turn the four retainers 90 degrees to disengage the clips and remove the fuel pump inspection hole cover.

CAUTION:

Cover the immediate area surrounding the fuel pump inspection hole cover with plastic to avoid gasoline damage to carpet.

7. Disconnect harness connector (A) and quick connector (B).

↔ : Front

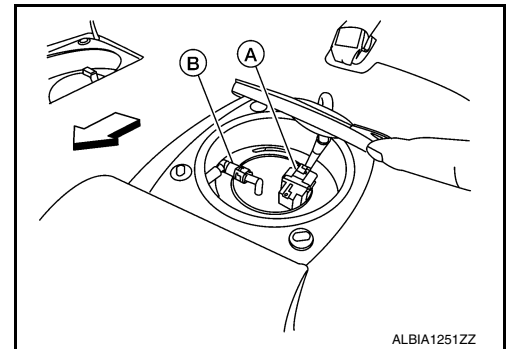
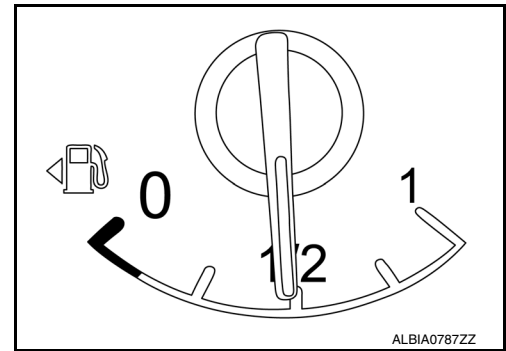

Disconnect quick connector as follows:

- Hold the sides of connector, press tabs and pull out fuel feed tube.

(A) : Pull

(B) : Push in tabs

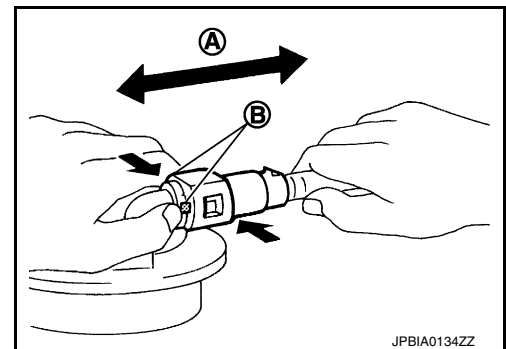

- If quick connector sticks to tube of main fuel level sensor unit, push and pull quick connectors several times until they start to move. Then disconnect them by pulling.

CAUTION:

FUEL TANK

< REMOVAL AND INSTALLATION >

- **Quick connector (1) can be disconnected when the tabs (F) are depressed completely. Do not twist it more than necessary.**

(B) : Connection (cross-section)
(D) : To under floor fuel line
(E) : To fuel tank
(G) : Disconnection

- **Do not use any tools to disconnect quick connector.**
- **Keep resin tube (C) away from heat. Be especially careful when welding near the resin tube.**
- **Prevent acid liquid such as battery electrolyte, etc., from getting on resin tube.**
- **Do not bend or twist resin tube during installation and disconnection.**
- **Do not remove the remaining retainer (2) from hard tube (or the equivalent) (A) except when resin tube or retainer is replaced.**
- **When resin tube or hard tube (or the equivalent) is replaced, also replace retainer with new one.**

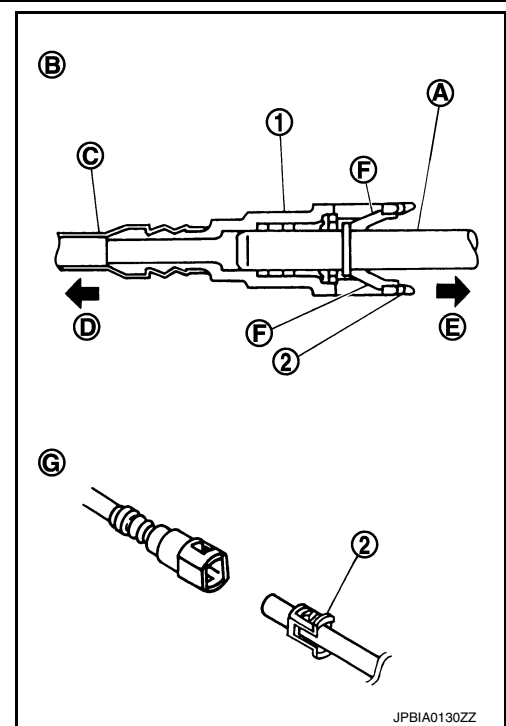

- **To keep the connecting portions clean and to avoid damage and foreign materials, cover them completely with plastic bags (A) or something similar.**

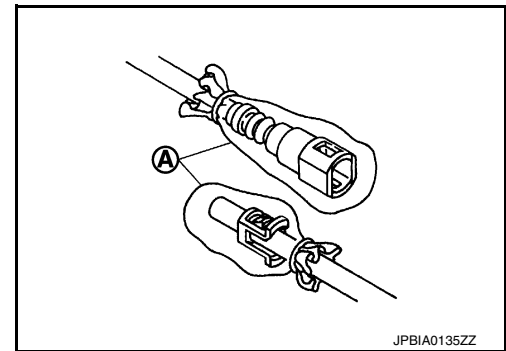

8. Turn the four retainers 90 degrees to disengage the clips and remove the sub fuel sender inspection hole cover.

CAUTION:

Cover the immediate area surrounding the fuel pump inspection hole cover with plastic to avoid gasoline damage to carpet.

9. Disconnect the harness connector from the sub fuel level sensor assembly.
10. Remove floor undercover (LH/RH). Refer to [EXT-40, "FLOOR UNDER COVER : Removal and Installation"](#).
11. Remove center exhaust tube. Refer to [EX-5, "Exploded View"](#).
12. Loosen front parking brake cable and remove from equalizer. Refer to [PB-7, "Exploded View"](#).
13. Remove rear parking brake cable brackets. Refer to [PB-7, "Exploded View"](#).
14. Remove fuel tank protector.
15. Remove rear undercover (LH/RH). Refer to [EXT-40, "REAR UNDER COVER : Removal and Installation"](#).
16. Remove rear stabilizer bar clamp and position rear stabilizer bar aside. Refer to [RSU-16, "Exploded View"](#).
17. Remove vent hose at rear side of fuel tank.
18. Disconnect EVAP tube at rear side of fuel tank. Refer to [FL-11, "FWD : Exploded View"](#).
19. Remove fuel filler hose at fuel filler tube side.

FUEL TANK

< REMOVAL AND INSTALLATION >

20. Support center of fuel tank (1) with suitable jack (A).

CAUTION:

Securely support the fuel tank with a piece of wood (B).

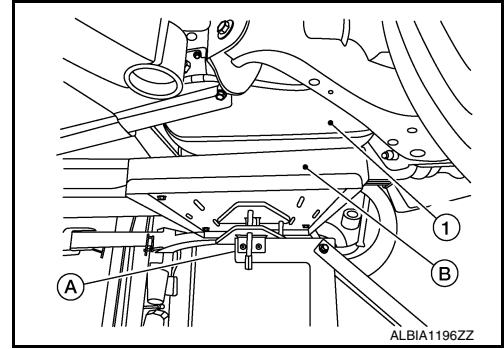

21. Remove fuel tank bands.

22. Lower suitable jack carefully to remove fuel tank while holding it by hand.

CAUTION:

Fuel tank may be in an unstable condition because of the shape of fuel tank bottom. Be sure to secure fuel tank at all times.

23. If replacing the fuel tank, remove sub fuel level sensor assembly, fuel level sensor unit, fuel filter and fuel pump assembly to transfer to the new fuel tank. Remove and discard O-ring. Refer to [FL-5, "Removal and Installation"](#).

INSTALLATION

Installation is in the reverse order of removal.

Fuel Filler Hose

- Insert fuel filler hose to the length below:

Length : 35 mm (1.38 in)

- Be sure hose clamp is not placed on swelled area of fuel filler tube.
- Tighten the clamp hand with the top mark (A) until the mark is on the bolt head flange.

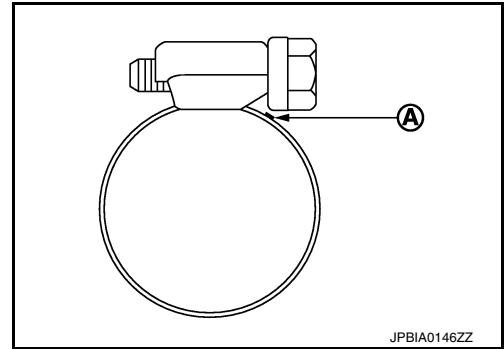

FWD : Inspection

INFOID:000000012891589

INSPECTION AFTER INSTALLATION

Use the following procedure to check for fuel leaks:

1. Turn the ignition switch ON (without starting the engine). Then check the connections for fuel leaks by applying fuel pressure to the fuel piping.
2. Start engine, raise idle and verify there are no leaks at the fuel system connections.

AWD

FUEL TANK

< REMOVAL AND INSTALLATION >

AWD : Exploded View

INFOID:000000012891590

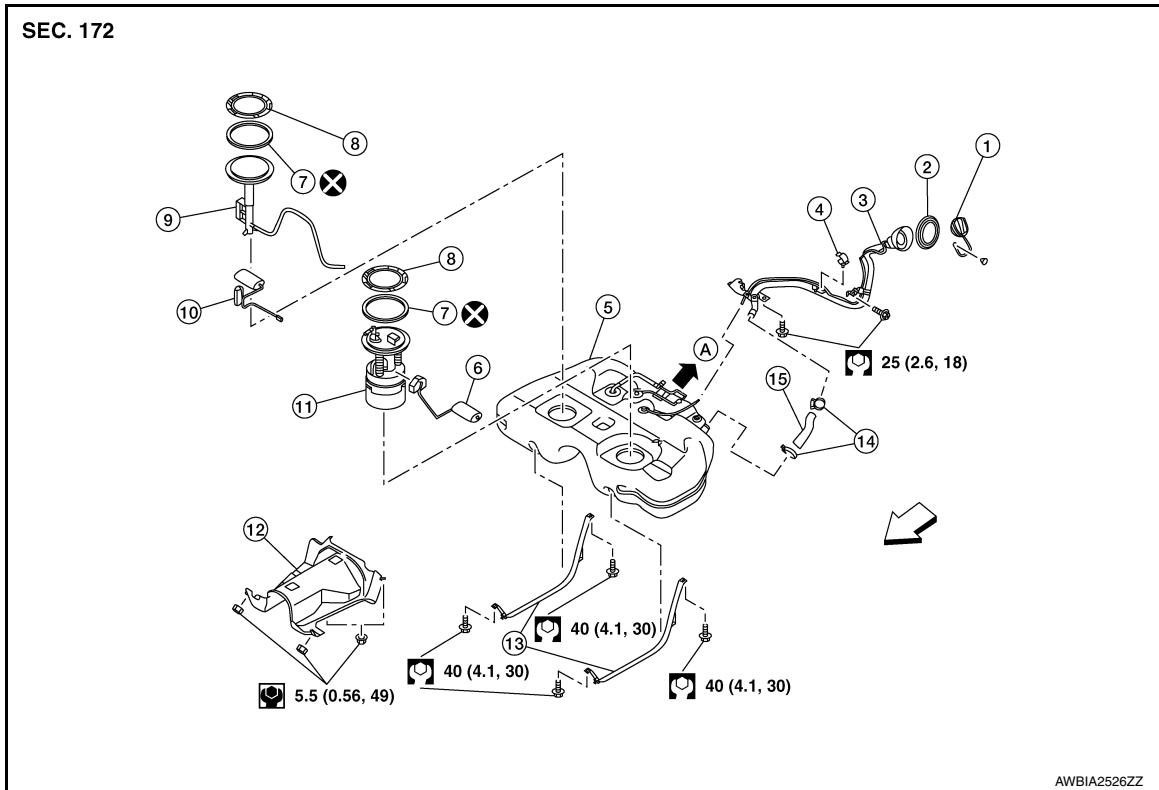

- | | | |
|---------------------------|----------------------------------------------------------------|----------------------------|
| 1. Fuel filler cap | 2. Grommet | 3. Fuel filler tube |
| 4. Clip | 5. Fuel tank | 6. Fuel level sensor |
| 7. O-ring | 8. Lock ring | 9. Sub fuel level assembly |
| 10. Sub fuel level sensor | 11. Fuel level sensor unit, fuel filter and fuel pump assembly | 12. Fuel tank protector |
| 13. Fuel tank strap | 14. Clamp | 15. Fuel filler hose |
| A. To EVAP canister | ↔ Front | |

AWD : Removal and Installation

INFOID:000000012891591

WARNING:

Be sure to read "General Precautions" when working on the fuel system. Refer to [FL-2, "General Precaution"](#).

NOTE:

When removing components such as hoses, tubes/lines, etc., cap or plug openings to prevent fluid from spilling.

REMOVAL

1. Check the fuel level with the vehicle on a level surface. If the fuel gauge indicates more than the level as shown (1/2 full), drain the fuel from the fuel tank until the fuel gauge indicates a level at or below as shown (1/2 full).
 - In case the fuel pump does not operate, use the following procedure:
 - a. Insert fuel tubing of less than 25 mm (0.98 in) diameter into the fuel filler tube through the fuel filler opening to drain fuel from the fuel filler tube.
 - b. Disconnect the fuel filler hose from the fuel filler tube.

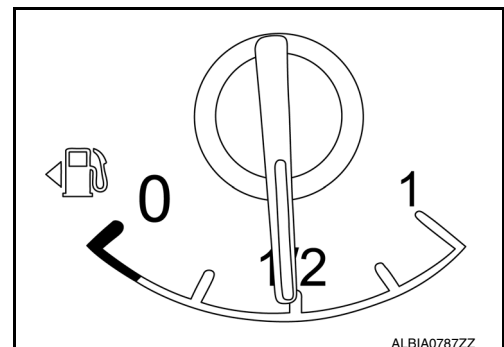

FUEL TANK

< REMOVAL AND INSTALLATION >

- c. Insert fuel tubing into the fuel tank through the fuel filler hose to drain fuel from the fuel tank.
 - As a guide, the fuel level reaches or is less than the level on the fuel gauge as shown when approximately 27.5 ℓ (7-1/4 US gal, 6 Imp gal) of fuel are drained from a full fuel tank.
2. Release fuel pressure from fuel lines. Refer to [EC-162. "Work Procedure"](#).
3. Disconnect negative battery terminal. Refer to [PG-112. "Removal and Installation"](#).
4. Unscrew the fuel filler cap to release the pressure inside the fuel tank.
5. Remove second row seat (LH/RH). Refer to [SE-135. "Removal and Installation"](#).
6. Turn the four retainers 90 degrees to disengage the clips and remove the fuel pump inspection hole cover.
CAUTION:
Cover the immediate area surrounding the fuel pump inspection hole cover with plastic to avoid gasoline damage to carpet.
7. Disconnect harness connector (A) and quick connector (B).

↔ : Front

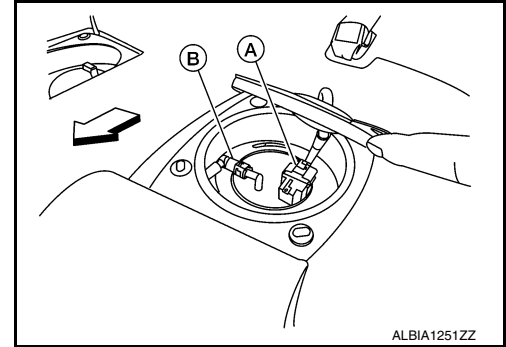

Disconnect quick connector as follows:

- Hold the sides of connector, press tabs and pull out fuel feed tube.

- (A) : Pull
- (B) : Push in tabs

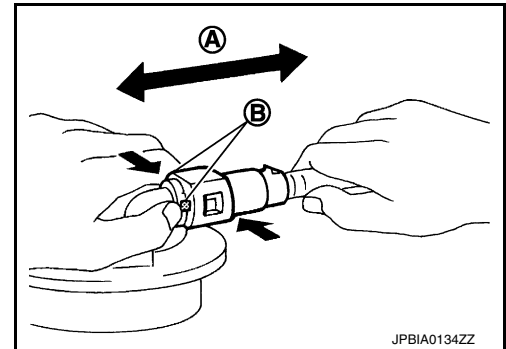

- If quick connector sticks to tube of main fuel level sensor unit, push and pull quick connectors several times until they start to move. Then disconnect them by pulling.

CAUTION:

FUEL TANK

< REMOVAL AND INSTALLATION >

- **Quick connector (1) can be disconnected when the tabs (F) are depressed completely. Do not twist it more than necessary.**

- (B) : Connection (cross-section)
- (D) : To under floor fuel line
- (E) : To fuel tank
- (G) : Disconnection

- **Do not use any tools to disconnect quick connector.**
- **Keep resin tube (C) away from heat. Be especially careful when welding near the resin tube.**
- **Prevent acid liquid such as battery electrolyte, etc., from getting on resin tube.**
- **Do not bend or twist resin tube during installation and disconnection.**
- **Do not remove the remaining retainer (2) from hard tube (or the equivalent) (A) except when resin tube or retainer is replaced.**
- **When resin tube or hard tube (or the equivalent) is replaced, also replace retainer with new one.**

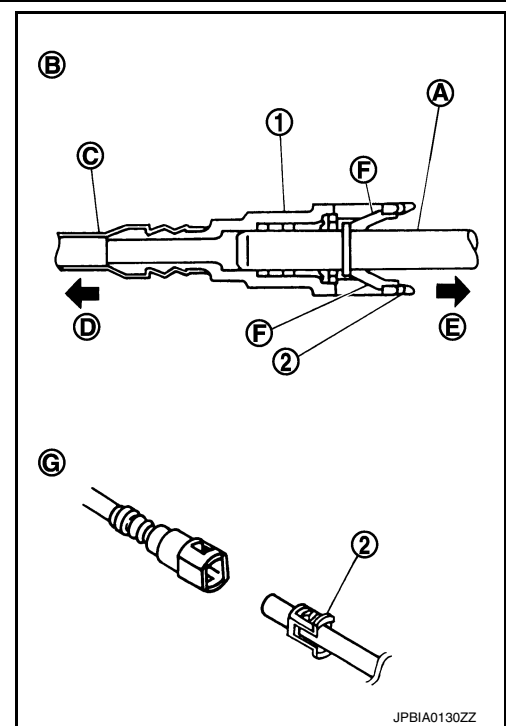

- **To keep the connecting portions clean and to avoid damage and foreign materials, cover them completely with plastic bags (A) or something similar.**

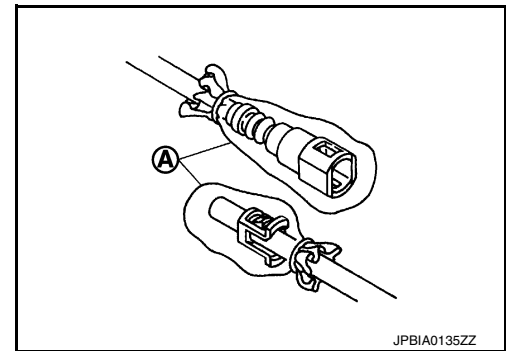

- Turn the four retainers 90 degrees to disengage the clips and remove the sub fuel sender inspection hole cover.

CAUTION:

Cover the immediate area surrounding the fuel pump inspection hole cover with plastic to avoid gasoline damage to carpet.

- Disconnect the harness connector from the sub fuel level sensor assembly.
- Remove floor undercover (LH/RH). Refer to [EXT-40, "FLOOR UNDER COVER : Removal and Installation"](#).
- Remove center exhaust tube. Refer to [EX-5, "Exploded View"](#).
- Remove propeller shaft. Refer to [DLN-89, "Removal and Installation"](#).
- Loosen front parking brake cable and remove from equalizer. Refer to [PB-7, "Exploded View"](#).
- Remove rear parking brake cable brackets. Refer to [PB-7, "Exploded View"](#).
- Remove protectors from fuel tank.
- Remove rear undercover (LH/RH). Refer to [EXT-40, "REAR UNDER COVER : Removal and Installation"](#).
- Remove rear stabilizer bar clamp and position rear stabilizer bar aside. Refer to [RSU-16, "Exploded View"](#).
- Remove vent hose at rear side of fuel tank.
- Disconnect EVAP tube at rear side of fuel tank. Refer to [FL-15, "AWD : Exploded View"](#).
- Remove fuel filler hose at fuel filler tube side.

FUEL TANK

< REMOVAL AND INSTALLATION >

21. Support center of fuel tank (1) with suitable jack (A).

CAUTION:

Securely support the fuel tank with a piece of wood (B).

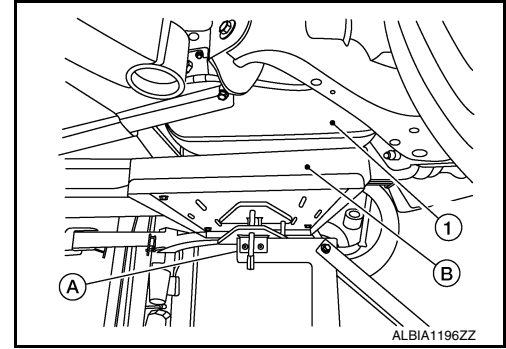

22. Remove fuel tank bands.

23. Lower suitable jack carefully to remove fuel tank while holding it by hand.

CAUTION:

Fuel tank may be in an unstable condition due to the shape of the fuel tank bottom. Be sure to secure tank at all times.

24. If replacing the fuel tank, remove the fuel level sensor unit, fuel filter and fuel pump assembly to transfer to the new fuel tank. Remove and discard the O-ring. Refer to [FL-5, "Removal and Installation"](#).

INSTALLATION

Installation is in the reverse order of removal.

Fuel Filler Hose

- Insert fuel filler hose to the length below:

Length : 35 mm (1.38 in)

- Be sure hose clamp is not placed on swelled area of fuel filler tube.
- Tighten the clamp hand with the top mark (A) until the mark is on the bolt head flange.

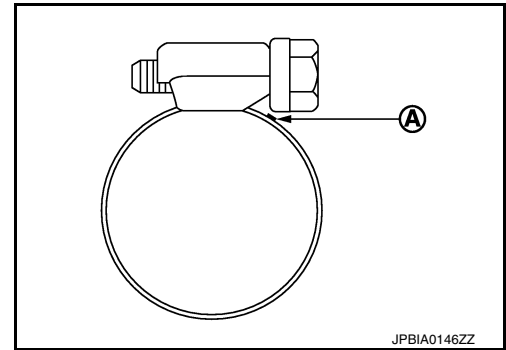

AWD : Inspection

INFOID:000000012891592

INSPECTION AFTER INSTALLATION

Use the following procedure to check for fuel leaks:

1. Turn the ignition switch ON (without starting the engine). Then check the connections for fuel leaks by applying fuel pressure to the fuel piping.
2. Start engine, raise idle and verify there are no leaks at the fuel system connections.

EVAP CANISTER

< REMOVAL AND INSTALLATION >

EVAP CANISTER

Exploded View

INFOID:000000012891593

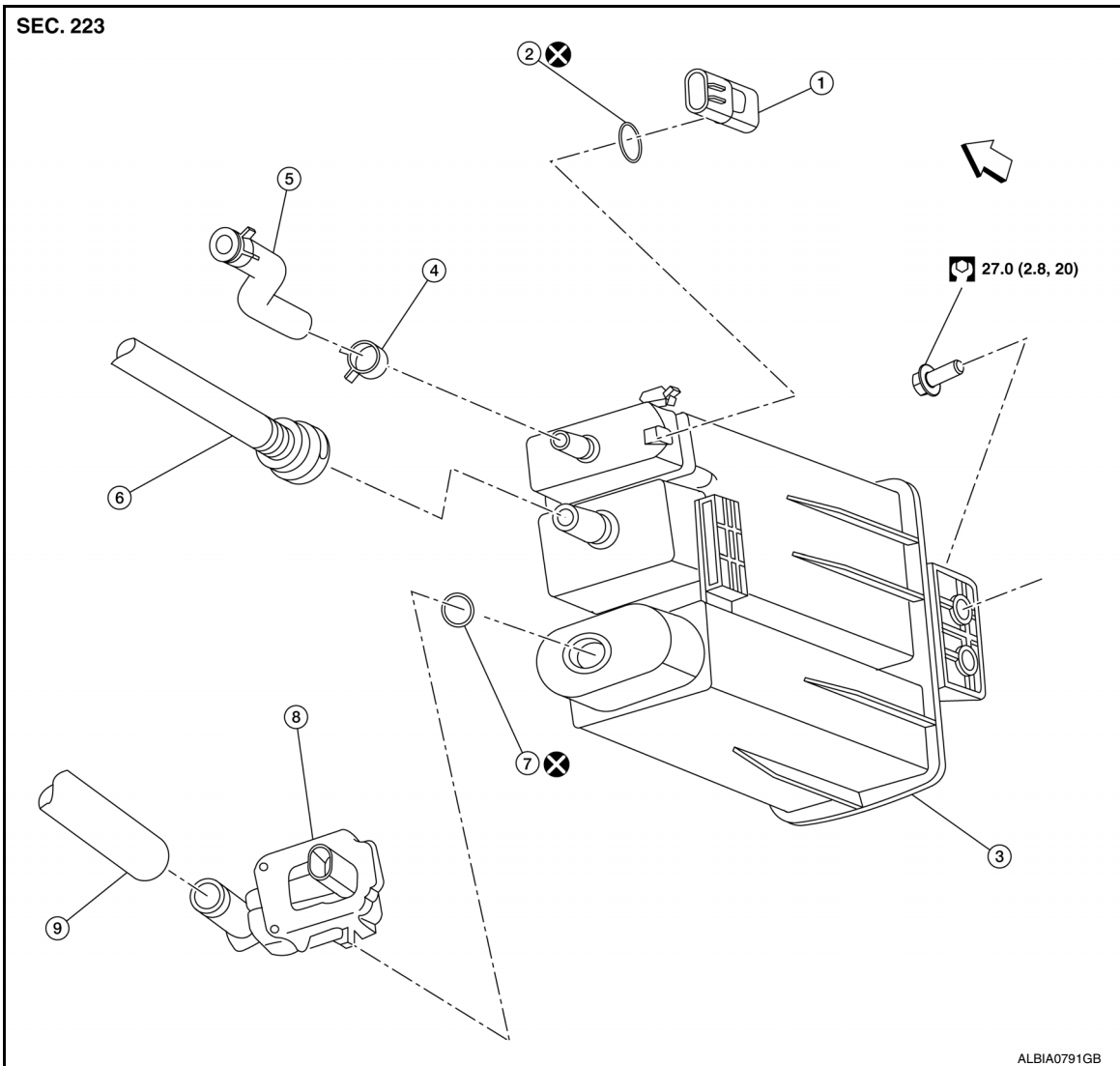

- | | | |
|------------------------------------------|-------------------------------------|------------------------------------------|
| 1. EVAP canister control pressure sensor | 2. O-ring | 3. EVAP canister |
| 4. Hose clamp | 5. EVAP canister purge hose | 6. EVAP canister vent line |
| 7. O-ring | 8. EVAP canister vent control valve | 9. EVAP canister vent control valve hose |

↩ Front

Removal and Installation

INFOID:000000012891594

NOTE:

The EVAP canister vent control valve and EVAP canister control pressure sensor can be removed without removing the EVAP canister.

REMOVAL

1. Disconnect EVAP canister purge hose, EVAP canister vent line, and EVAP canister vent control valve hose.
2. Disconnect EVAP canister control pressure sensor harness connector and EVAP canister vent control valve harness connector.

EVAP CANISTER

< REMOVAL AND INSTALLATION >

3. Remove EVAP canister bolt.
4. Remove EVAP canister from the vehicle.

INSTALLATION

Installation is in the reverse order of removal.

CAUTION:

Do not reuse O-ring.

Inspection

Check EVAP canister as follows:

1. Block port (A).
2. Blow air into port (B) and check that it flows freely out of port (C).
3. Release blocked port (A).
4. Apply vacuum pressure to port (A) and check that vacuum pressure exists at the ports (B) and (C).
5. Block port (B) and (A).
6. Apply vacuum pressure to port (C) and check that there is no leakage.

INFOID:000000012891595

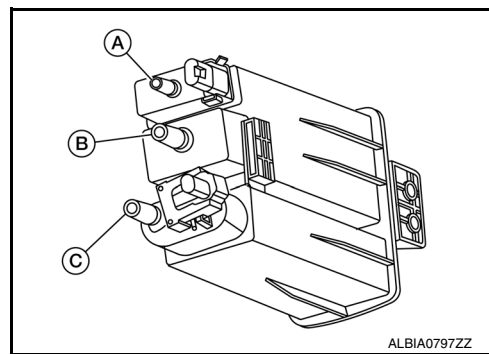

EVAP CANISTER FILTER

< REMOVAL AND INSTALLATION >

EVAP CANISTER FILTER

Exploded View

INFOID:000000012891596

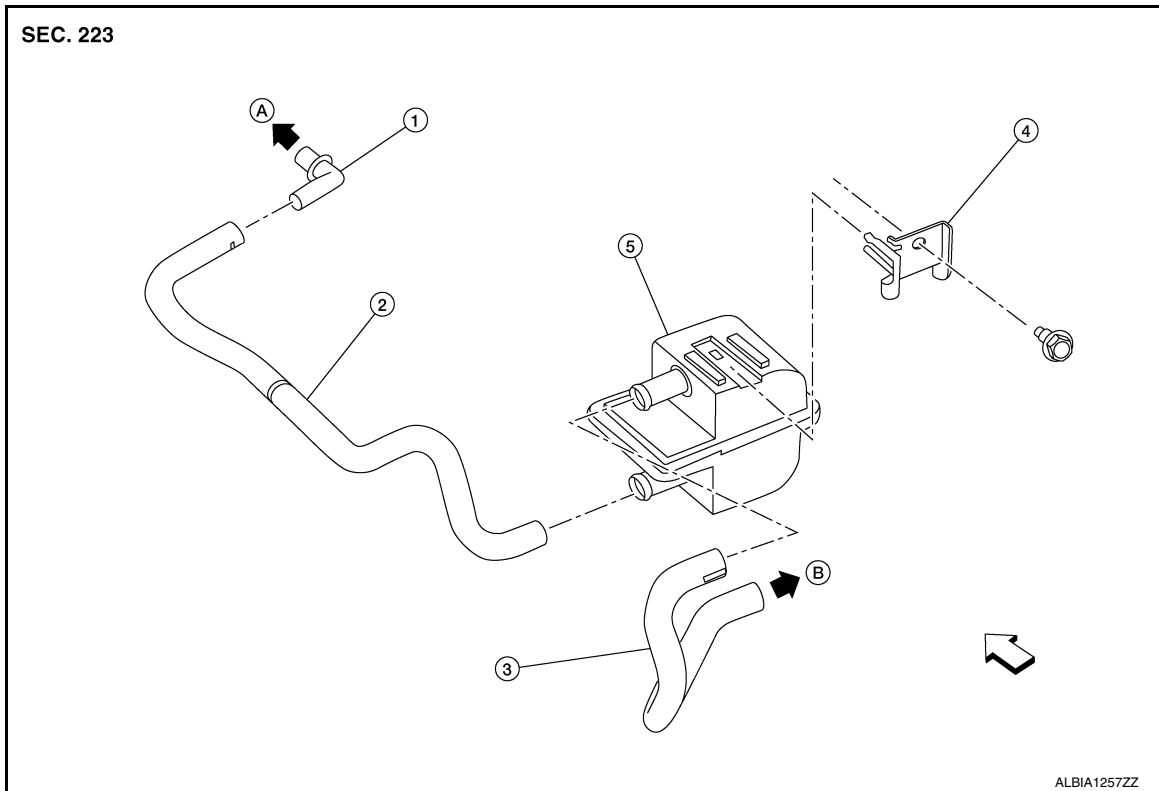

- | | | |
|---------------------------------|-------------------------|------------------------------------------|
| 1. Plug | 2. Canister drain hose | 3. EVAP canister vent control valve hose |
| 4. EVAP canister filter bracket | 5. EVAP canister filter | A. To vehicle body |
| B. To EVAP canister | ⇐ Front | |

Removal and Installation

INFOID:000000012891597

REMOVAL

1. Disconnect EVAP canister vent control valve hose from EVAP canister filter.
2. Disconnect canister drain hose from EVAP canister filter.
3. Remove EVAP canister filter.
4. Remove EVAP canister filter bracket (if necessary).

INSTALLATION

Installation is in the reverse order of removal.

EVAP CANISTER VENT CONTROL VALVE

< REMOVAL AND INSTALLATION >

EVAP CANISTER VENT CONTROL VALVE

Exploded View

INFOID:000000012891598

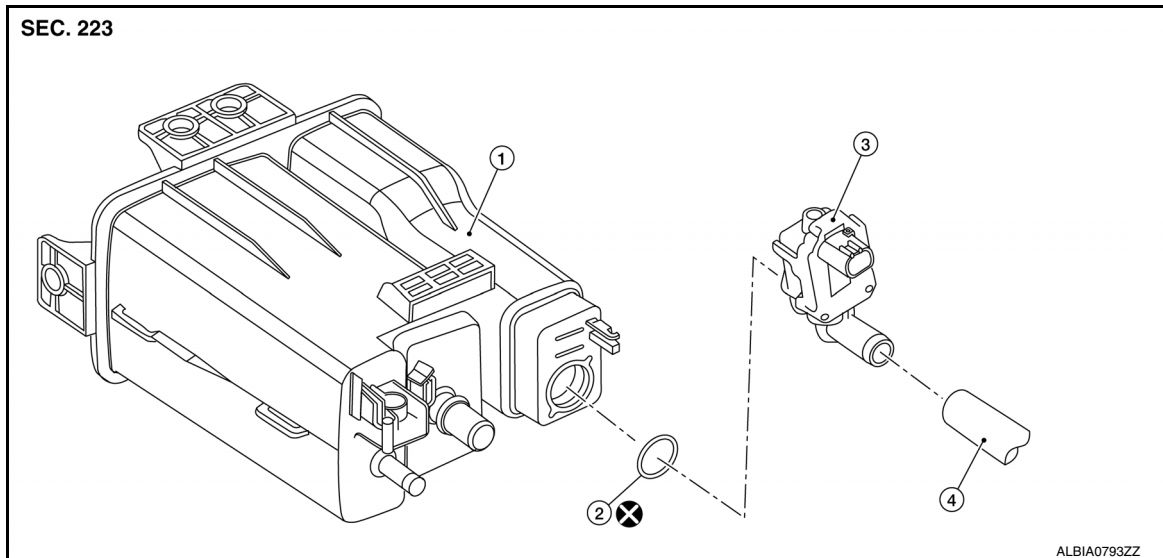

- 1. EVAP canister
- 2. O-ring
- 3. EVAP canister vent control valve
- 4. EVAP canister vent control valve hose

Removal and Installation

INFOID:000000012891599

NOTE:

The EVAP canister vent control valve can be removed without removing the EVAP canister.

REMOVAL

1. Disconnect EVAP canister vent control valve hose from EVAP canister vent control valve.
2. Disconnect EVAP canister vent control valve harness connector.
3. Turn EVAP canister vent control valve counterclockwise.

- (A) : Lock
- (B) : Unlock

4. Remove EVAP canister vent control valve and O-ring.

CAUTION:

Discard the O-ring. Do not reuse O-ring.

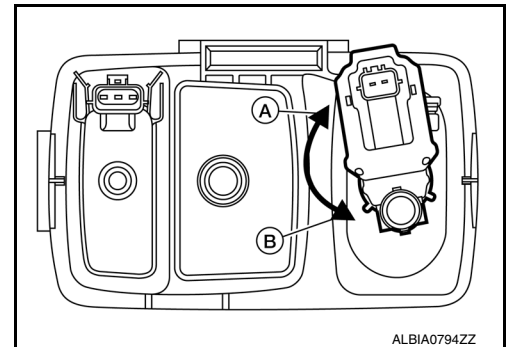

INSTALLATION

Installation is in the reverse order of removal.

CAUTION:

Do not reuse O-ring.

EVAP CONTROL SYSTEM PRESSURE SENSOR

< REMOVAL AND INSTALLATION >

EVAP CONTROL SYSTEM PRESSURE SENSOR

Exploded View

INFOID:000000012891600

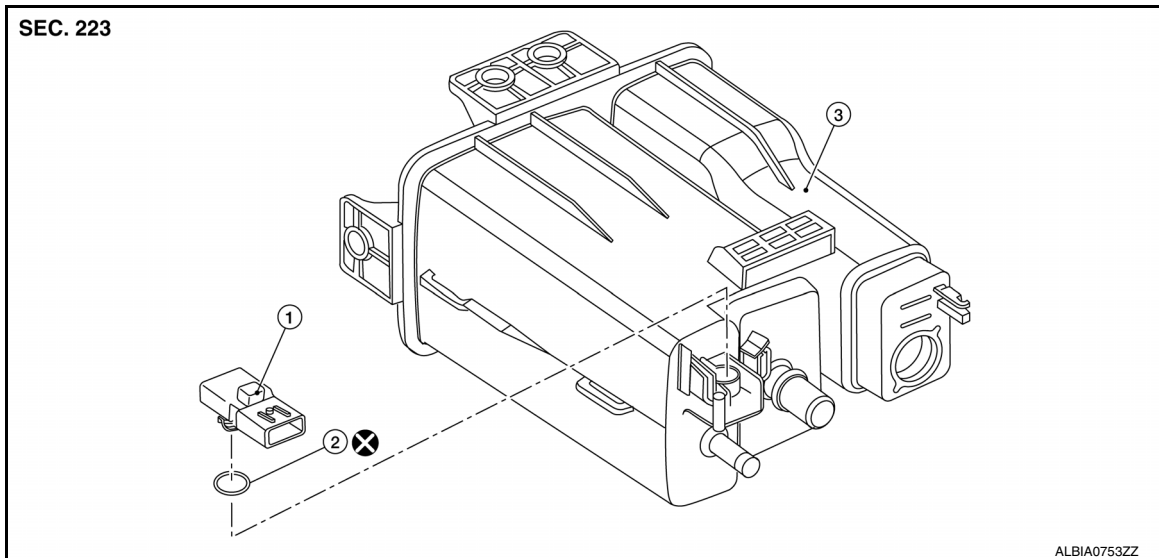

1. EVAP canister control pressure sensor
2. O-ring
3. EVAP canister

Removal and Installation

INFOID:000000012891601

NOTE:

The EVAP canister control pressure sensor cannot be removed without removing the EVAP canister.

REMOVAL

1. Remove EVAP canister. Refer to [FL-19, "Removal and Installation"](#).
2. Remove EVAP canister control pressure sensor and O-ring.

CAUTION:

Discard the O-ring. Do not reuse O-ring.

INSTALLATION

Installation is in the reverse order of removal.

CAUTION:

Do not reuse O-ring.

FUEL LEVEL SENSOR UNIT

< DISASSEMBLY AND ASSEMBLY >

DISASSEMBLY AND ASSEMBLY

FUEL LEVEL SENSOR UNIT

Exploded View

INFOID:000000012891602

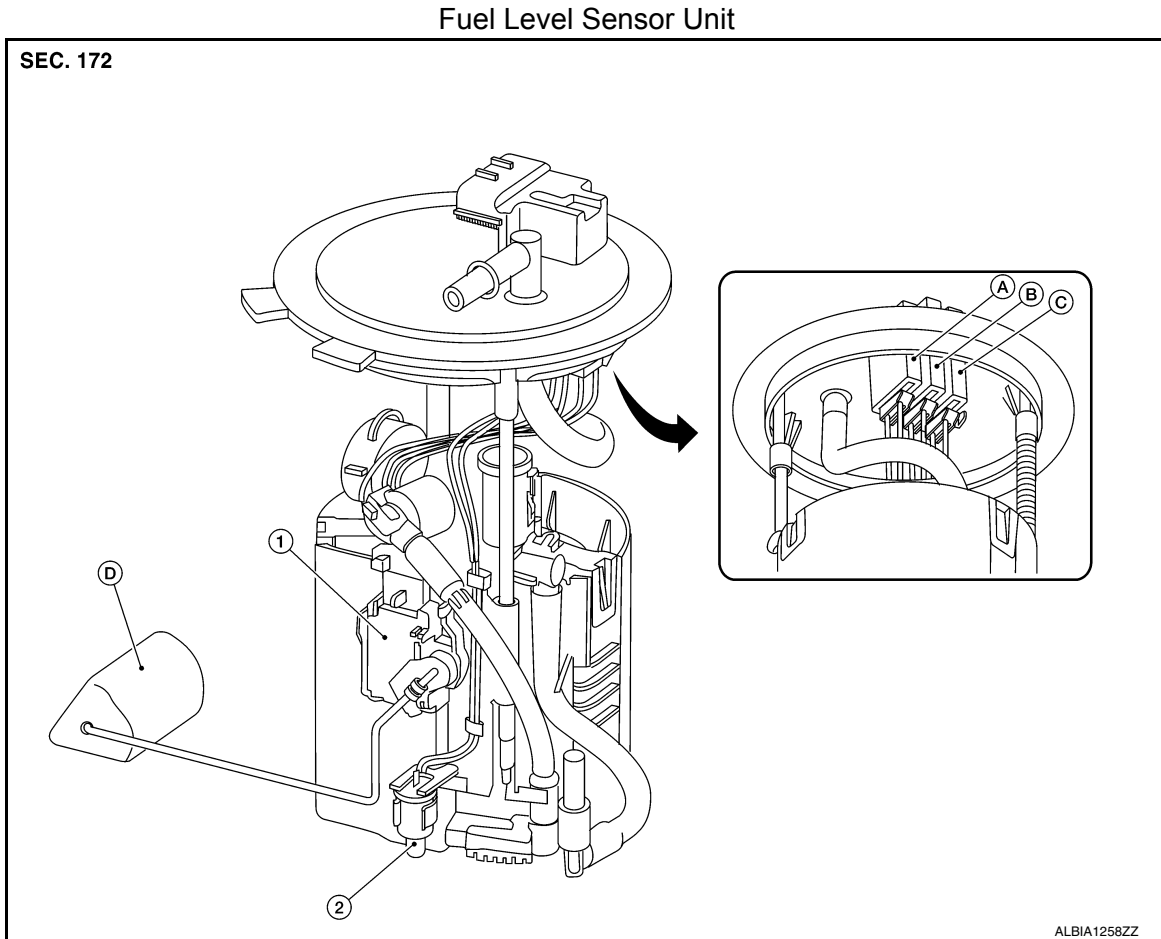

- | | | |
|--------------------------------|---------------------------------------------------|---------------------------------------------|
| 1. Fuel level sensor unit | 2. Fuel tank temperature sensor | A. Fuel level sensor unit harness connector |
| B. Fuel pump harness connector | C. Fuel tank temperature sensor harness connector | D. Float arm assembly |

Disassembly and Assembly

INFOID:000000012891603

Disassembly

NOTE:

Before disassembly, note the proper placement of the wires to the correct terminals and correct wire routing to the terminals.

1. Disconnect fuel level sensor unit (A) and fuel tank temperature sensor (C) harness connectors. Press the tabs on the terminals to release the locking tabs.

(B) : Fuel pump harness connector

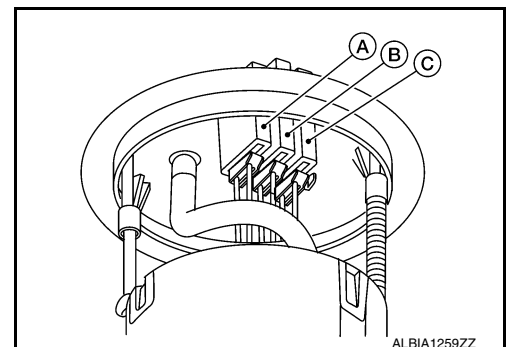

FUEL LEVEL SENSOR UNIT

< DISASSEMBLY AND ASSEMBLY >

2. Release two clips and remove fuel tank temperature sensor (1) from pump assembly.

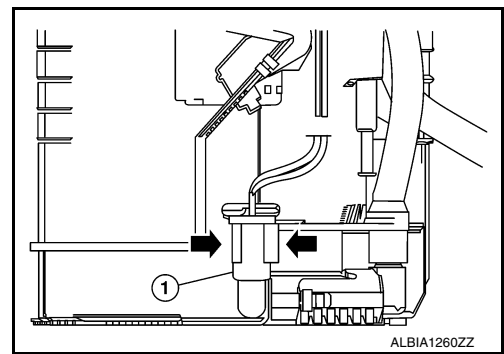

3. Release tab (A) and slide fuel level sensor unit and float arm assembly up (B) to remove.

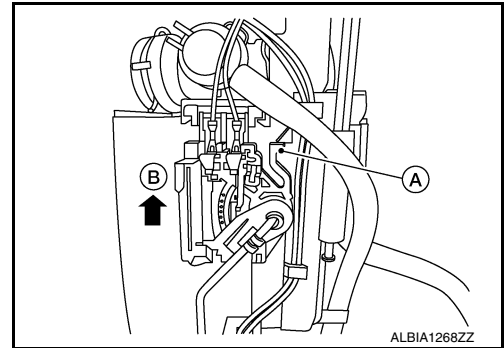

Assembly

Assembly is in the reverse order of disassembly.

NOTE:

- Ensure proper placement of the wires to the correct terminals and correct wire routing to the terminals.
- After connecting terminals, ensure they are securely locked and cannot be pulled out.
- When installing the fuel level sensor unit, push down until the tab is locked into place.

A
FL
C
D
E
F
G
H
I
J
K
L
M
N
O
P

SERVICE DATA AND SPECIFICATIONS (SDS)

< SERVICE DATA AND SPECIFICATIONS (SDS)

SERVICE DATA AND SPECIFICATIONS (SDS)

SERVICE DATA AND SPECIFICATIONS (SDS)

Fuel Tank

INFOID:0000000012891604

Standard and Limit

Fuel tank capacity	Approx. 71.9 ℓ (19 US gal, 15-7/8 Imp gal)
Fuel recommendation	Refer to MA-12. "Fluids and Lubricants" .