

SECTION HAC

HEATER & AIR CONDITIONING CONTROL SYSTEM

CONTENTS

| | | |
|--|----|--|
| AUTOMATIC AIR CONDITIONING | | |
| PRECAUTION | 4 | |
| PRECAUTIONS | 4 | |
| Precaution for Supplemental Restraint System (SRS) "AIR BAG" and "SEAT BELT PRE-TENSIONER" | 4 | |
| Precaution for Work | 4 | |
| PREPARATION | 5 | |
| PREPARATION | 5 | |
| Special Service Tool | 5 | |
| Commercial Service Tool | 5 | |
| SYSTEM DESCRIPTION | 6 | |
| COMPONENT PARTS | 6 | |
| Component Parts Location | 6 | |
| Intake Sensor | 8 | |
| Air Mix Door Motor LH | 8 | |
| Air Mix Door Motor RH | 8 | |
| Mode Door Motor | 8 | |
| Intake Door Motor | 8 | |
| Front Blower Motor | 9 | |
| A/C Compressor | 9 | |
| A/C Auto Amp. | 10 | |
| Ambient Sensor | 10 | |
| In-vehicle Sensor | 10 | |
| Sunload Sensor | 10 | |
| Refrigerant Pressure Sensor | 10 | |
| SYSTEM | 12 | |
| System Description | 12 | |
| Air Flow Control | 13 | |
| Air Inlet Control | 14 | |
| Air Outlet Control | 15 | |
| Compressor Control | 15 | |
| Door Control | 16 | |
| Temperature Control | 18 | |
| Fail-safe | 18 | |
| OPERATION | 19 | |
| Switch Name and Function | 19 | |
| DIAGNOSIS SYSTEM (HVAC) | 21 | |
| Description | 21 | |
| CONSULT Function | 21 | |
| ECU DIAGNOSIS INFORMATION | 23 | |
| A/C AUTO AMP. | 23 | |
| Reference Value | 23 | |
| Fail-safe | 26 | |
| DTC Index | 26 | |
| ECM, IPDM E/R, BCM | 28 | |
| List of ECU Reference | 28 | |
| WIRING DIAGRAM | 29 | |
| AUTOMATIC AIR CONDITIONING SYSTEM ... | 29 | |
| Wiring Diagram | 29 | |
| BASIC INSPECTION | 36 | |
| DIAGNOSIS AND REPAIR WORK FLOW | 36 | |
| Work Flow | 36 | |
| OPERATION INSPECTION | 39 | |
| Work Procedure | 39 | |
| ADDITIONAL SERVICE WHEN REPLACING CONTROL UNIT (A/C AUTO AMP.) | 41 | |
| Description | 41 | |
| Work Procedure | 41 | |
| CONFIGURATION (HVAC) | 42 | |
| Description | 42 | |
| Work Procedure | 42 | |
| SYSTEM SETTING | 43 | |
| Temperature Setting Trimmer (Front) | 43 | |
| Foot Position Setting Trimmer | 43 | |
| Inlet Port Memory Function (FRE) | 44 | |

A
B
C
D
E
F
G
H
HAC
J
K
L
M
N
O
P

| | | | |
|---|----|--|----|
| Inlet Port Memory Function (REC) | 44 | A/C AUTO AMP. | 70 |
| DTC/CIRCUIT DIAGNOSIS | 45 | A/C AUTO AMP. : Diagnosis Procedure | 70 |
| U1000 CAN COMM CIRCUIT | 45 | AIR MIX DOOR MOTOR (DRIVER SIDE) | 70 |
| DTC Description | 45 | AIR MIX DOOR MOTOR (DRIVER SIDE) : Diag- | |
| Diagnosis Procedure | 45 | nosis Procedure | 70 |
| U1010 CONTROL UNIT (CAN) | 46 | AIR MIX DOOR MOTOR (PASSENGER SIDE) | 71 |
| DTC Description | 46 | AIR MIX DOOR MOTOR (PASSENGER SIDE) : | |
| Diagnosis Procedure | 46 | Diagnosis Procedure | 71 |
| B2578, B2579 IN-VEHICLE SENSOR | 47 | MODE DOOR MOTOR | 72 |
| DTC Description | 47 | MODE DOOR MOTOR : Diagnosis Procedure | 72 |
| Diagnosis Procedure | 47 | INTAKE DOOR MOTOR | 73 |
| Component Inspection | 49 | INTAKE DOOR MOTOR : Diagnosis Procedure ... | 73 |
| B257B, B257C AMBIENT SENSOR | 50 | DOOR MOTOR | 75 |
| DTC Description | 50 | Diagnosis Procedure | 75 |
| Diagnosis Procedure | 50 | DOOR MOTOR COMMUNICATION CIRCUIT... | 77 |
| Component Inspection | 52 | Diagnosis Procedure | 77 |
| B2581, B2582 INTAKE SENSOR | 53 | FRONT BLOWER MOTOR | 78 |
| DTC Description | 53 | Diagnosis Procedure | 78 |
| Diagnosis Procedure | 53 | Component Inspection (Front Blower Motor) | 79 |
| Component Inspection | 55 | Component Inspection (Front Blower Motor Re- | |
| B2630, B2631 SUNLOAD SENSOR | 56 | lay) | 79 |
| DTC Description | 56 | MAGNET CLUTCH | 81 |
| Diagnosis Procedure | 56 | Component Function Check | 81 |
| Component Inspection | 57 | Diagnosis Procedure | 81 |
| B2632, B2633 AIR MIX DOOR MOTOR | | ECV (ELECTRICAL CONTROL VALVE) | 82 |
| (DRIVER SIDE) | 59 | Diagnosis Procedure | 82 |
| DTC Description | 59 | Component Inspection | 83 |
| Diagnosis Procedure | 59 | SYMPTOM DIAGNOSIS | 84 |
| B2634, B2635 AIR MIX DOOR MOTOR (PAS- | | AUTOMATIC AIR CONDITIONING SYSTEM ... | 84 |
| SENGER SIDE) | 61 | Diagnosis Chart By Symptom | 84 |
| DTC Description | 61 | INSUFFICIENT COOLING | 86 |
| Diagnosis Procedure | 61 | Description | 86 |
| B2636, B2637, B2638, B2639, B2654, B2655 | | Diagnosis Procedure | 86 |
| MODE DOOR MOTOR | 63 | INSUFFICIENT HEATING | 88 |
| DTC Description | 63 | Description | 88 |
| Diagnosis Procedure | 64 | Diagnosis Procedure | 88 |
| B263D, B263E, B263F INTAKE DOOR MO- | | COMPRESSOR DOES NOT OPERATE | 89 |
| TOR | 65 | Description | 89 |
| DTC Description | 65 | Diagnosis Procedure | 89 |
| Diagnosis Procedure | 65 | REMOVAL AND INSTALLATION | 91 |
| B2796 CONTROL COMMUNICATION | 67 | A/C SWITCH ASSEMBLY | 91 |
| DTC Description | 67 | Removal and Installation | 91 |
| Diagnosis Procedure | 67 | A/C AUTO AMP. | 92 |
| B27B0 A/C AUTO AMP. | 69 | Exploded View | 92 |
| DTC Description | 69 | Removal and Installation | 92 |
| Diagnosis Procedure | 69 | | |
| POWER SUPPLY AND GROUND CIRCUIT | 70 | | |

| | | | | |
|--|-----------|--|------------|------------|
| AMBIENT SENSOR | 93 | DOOR MOTOR | 98 | |
| Removal and Installation | 93 | Exploded View | 98 | A |
| IN-VEHICLE SENSOR | 94 | MODE DOOR MOTOR | 99 | |
| Removal and Installation | 94 | MODE DOOR MOTOR : Removal and Installation... | 99 | B |
| SUNLOAD SENSOR | 95 | AIR MIX DOOR MOTOR | 99 | |
| Removal and Installation | 95 | AIR MIX DOOR MOTOR : Removal and Installation - (LH) | 99 | C |
| INTAKE SENSOR | 96 | AIR MIX DOOR MOTOR : Removal and Installation - (RH) | 99 | |
| Removal and Installation | 96 | INTAKE DOOR MOTOR | 100 | D |
| REFRIGERANT PRESSURE SENSOR | 97 | INTAKE DOOR MOTOR : Removal and Installation | 100 | E |
| Removal and Installation | 97 | | | F |
| | | | | G |
| | | | | H |
| | | | | HAC |
| | | | | J |
| | | | | K |
| | | | | L |
| | | | | M |
| | | | | N |
| | | | | O |
| | | | | P |

PRECAUTION

PRECAUTIONS

Precaution for Supplemental Restraint System (SRS) "AIR BAG" and "SEAT BELT PRE-TENSIONER"

INFOID:000000013384005

The Supplemental Restraint System such as "AIR BAG" and "SEAT BELT PRE-TENSIONER", used along with a front seat belt, helps to reduce the risk or severity of injury to the driver and front passenger for certain types of collision. Information necessary to service the system safely is included in the SR and SB section of this Service Manual.

WARNING:

- To avoid rendering the SRS inoperative, which could increase the risk of personal injury or death in the event of a collision which would result in air bag inflation, it is recommended that all maintenance and repair be performed by an authorized NISSAN/INFINITI dealer.
- Improper repair, including incorrect removal and installation of the SRS, can lead to personal injury caused by unintentional activation of the system. For removal of Spiral Cable and Air Bag Module, see the SR section.
- Do not use electrical test equipment on any circuit related to the SRS unless instructed to in this Service Manual. SRS wiring harnesses can be identified by yellow and/or orange harnesses or harness connectors.

PRECAUTIONS WHEN USING POWER TOOLS (AIR OR ELECTRIC) AND HAMMERS

WARNING:

- When working near the Air Bag Diagnosis Sensor Unit or other Air Bag System sensors with the Ignition ON or engine running, DO NOT use air or electric power tools or strike near the sensor(s) with a hammer. Heavy vibration could activate the sensor(s) and deploy the air bag(s), possibly causing serious injury.
- When using air or electric power tools or hammers, always switch the Ignition OFF, disconnect the battery or batteries, and wait at least three minutes before performing any service.

Precaution for Work

INFOID:000000012876723

- When removing or disassembling each component, be careful not to damage or deform it. If a component may be subject to interference, be sure to protect it with a shop cloth.
- When removing (disengaging) components with a screwdriver or similar tool, be sure to wrap the component with a shop cloth or vinyl tape to protect it.
- Protect the removed parts with a shop cloth and prevent them from being dropped.
- Replace a deformed or damaged clip.
- If a part is specified as a non-reusable part, always replace it with a new one.
- Be sure to tighten bolts and nuts securely to the specified torque.
- After installation is complete, be sure to check that each part works properly.
- Follow the steps below to clean components:
 - Water soluble dirt:
 - Dip a soft cloth into lukewarm water, wring the water out of the cloth and wipe the dirty area.
 - Then rub with a soft, dry cloth.
 - Oily dirt:
 - Dip a soft cloth into lukewarm water with mild detergent (concentration: within 2 to 3%) and wipe the dirty area.
 - Then dip a cloth into fresh water, wring the water out of the cloth and wipe the detergent off.
 - Then rub with a soft, dry cloth.
 - Do not use organic solvent such as thinner, benzene, alcohol or gasoline.
 - For genuine leather seats, use a genuine leather seat cleaner.

PREPARATION

< PREPARATION >

[AUTOMATIC AIR CONDITIONING]

PREPARATION

PREPARATION

Special Service Tool

INFOID:0000000012876724

The actual shape of the tools may differ from those illustrated here.

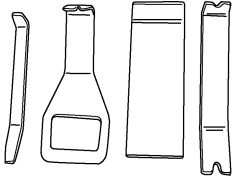
| (TechMate No.) Tool name | Description |
|--|--------------------------|
| (J-46534) Trim Tool Set  <p style="text-align: center;">AWJIA0483ZZ</p> | Removing trim components |

Commercial Service Tool

INFOID:0000000012876725

| Tool name | Description |
|---|----------------------------------|
| Power tool  <p style="text-align: center;">PIIB1407E</p> | Loosening nuts, screws and bolts |

A

B

C

D

E

F

G

H

HAC

J

K

L

M

N

O

P

SYSTEM DESCRIPTION

COMPONENT PARTS

Component Parts Location

INFOID:000000012876726

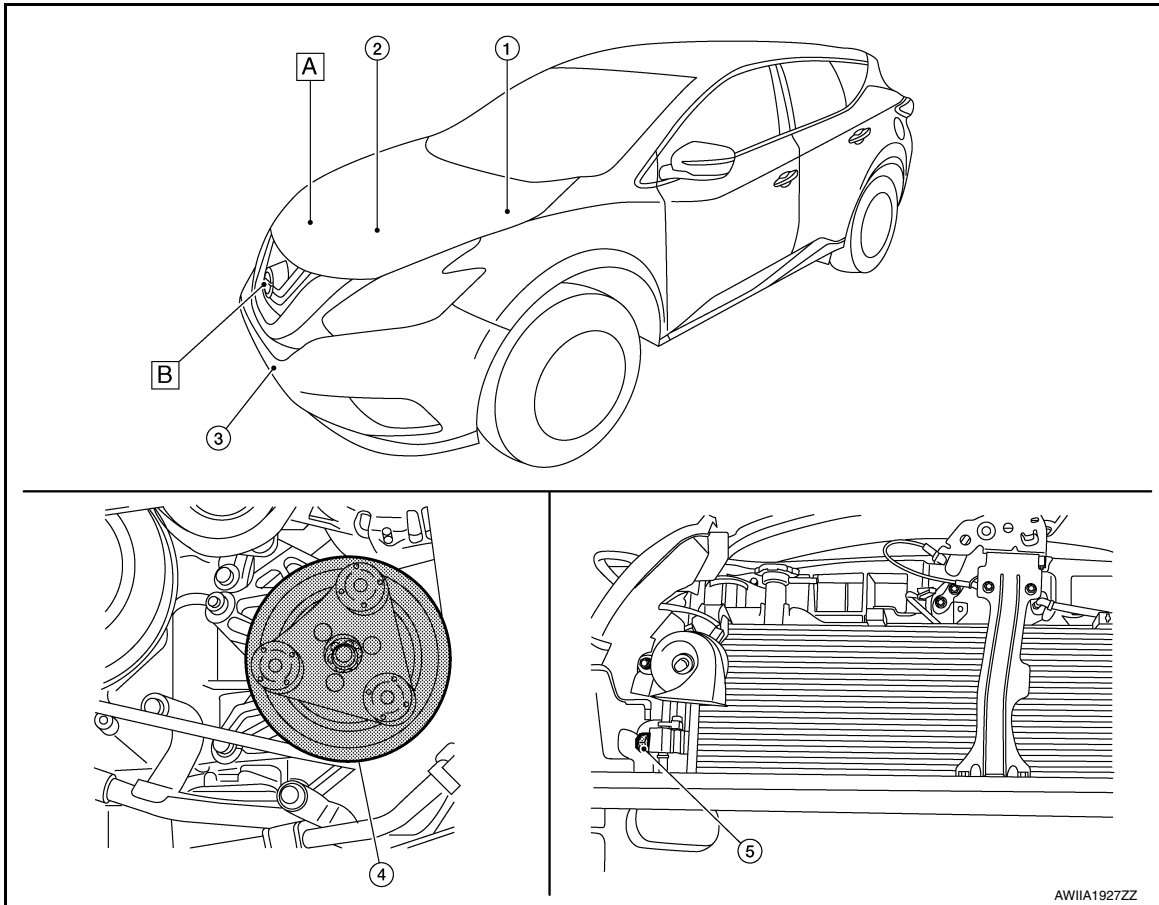

A. RH front of engine compartment

B. View with front fascia removed

| No. | Component | Description |
|-----|-----------------------------|---|
| 1. | IPDM E/R | A/C relay is integrated in IPDM E/R. IPDM E/R operates A/C relay when A/C compressor request signal is received from ECM via CAN communication line. Refer to PCS-5, "Component Parts Location" for detailed installation location. |
| 2. | ECM | The ECM sends a compressor ON request to the IPDM E/R based on the status of engine operation and load as well as refrigerant pressure information. If all the conditions are met for A/C operation, the ECM transmits the compressor ON request to the IPDM E/R. The ECM shares the refrigerant pressure sensor signal, engine RPM, and engine coolant temperature with the A/C auto amp. via CAN communication line. Refer to BCS-4, "BODY CONTROL SYSTEM : Component Parts Location" for detailed installation location. |
| 3. | Ambient sensor | Refer to HAC-10, "Ambient Sensor" . |
| 4. | A/C Compressor | Refer to HAC-9, "A/C Compressor" . |
| 5. | Refrigerant pressure sensor | Refer to HAC-10, "Refrigerant Pressure Sensor" . |

COMPONENT PARTS

< SYSTEM DESCRIPTION >

[AUTOMATIC AIR CONDITIONING]

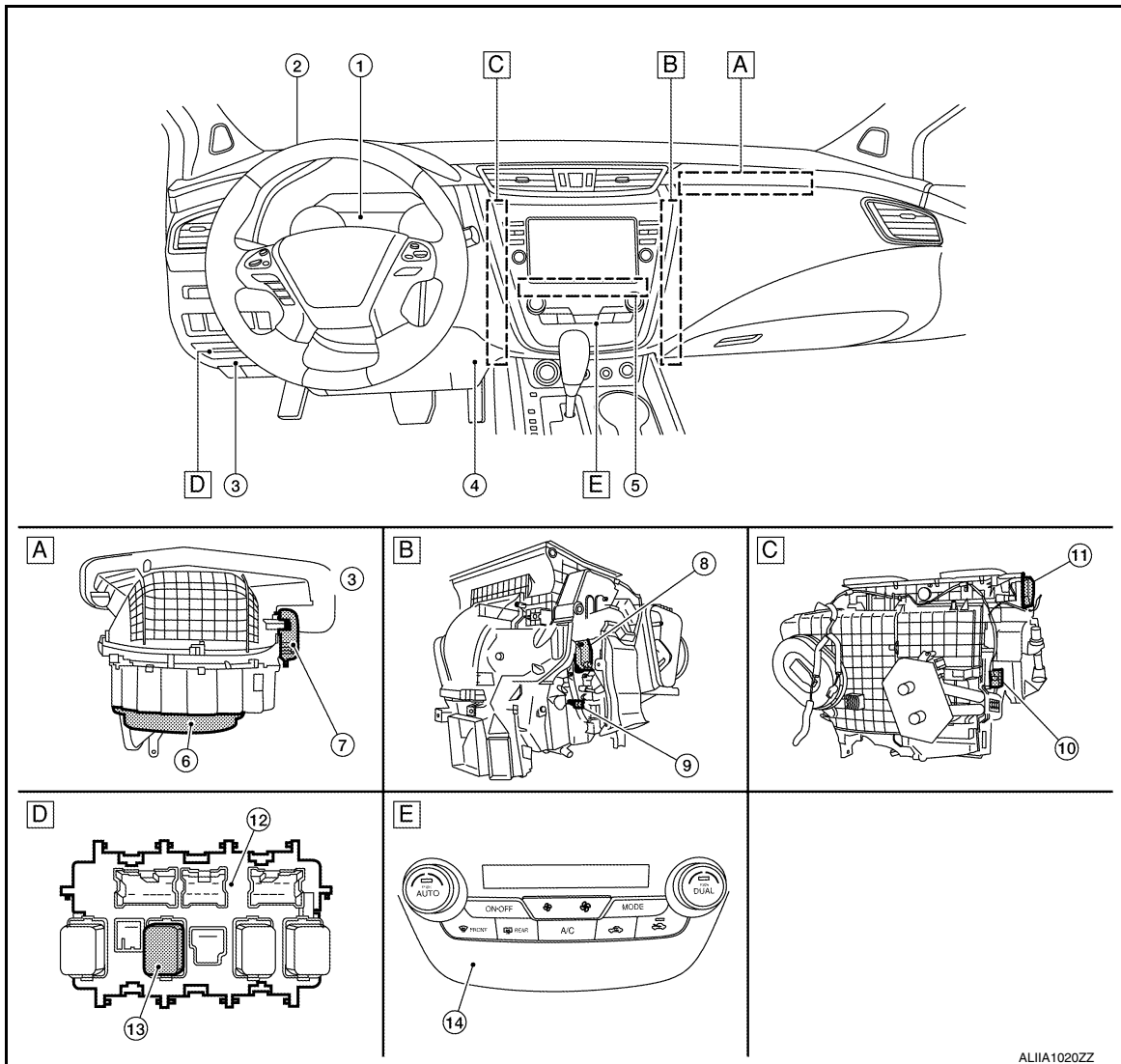

- A. Behind RH side of instrument panel (view with front blower assembly removed from vehicle)
 B. Behind RH center of instrument panel (view with A/C assembly removed from vehicle)
 C. Behind LH center of instrument panel (view with A/C assembly removed from vehicle)
 D. LH side of instrument panel
 E. Center of instrument panel

| No. | Component | Description |
|-----|-----------------------|--|
| 1. | BCM | BCM transmits blower motor ON signal to the front and rear blower motor relays. Refer to BCS-4, "BODY CONTROL SYSTEM : Component Parts Location" for detailed installation location. |
| 2. | Sunload sensor | Refer to HAC-10, "Sunload Sensor" . |
| 3. | Accessory relay-2 | Refer to PCS-7, "POWER CONSUMPTION CONTROL SYSTEM : System Description" . |
| 4. | In-vehicle sensor | Refer to HAC-10, "In-vehicle Sensor" . |
| 5. | A/C auto amp. | Refer to HAC-10, "A/C Auto Amp." |
| 6. | Front blower motor | Refer to HAC-9, "Front Blower Motor" . |
| 7. | Intake door motor | Refer to HAC-8, "Intake Door Motor" . |
| 8. | Mode door motor | Refer to HAC-8, "Mode Door Motor" . |
| 9. | Air mix door motor LH | Refer to HAC-8, "Air Mix Door Motor LH" . |
| 10. | Intake sensor | Refer to HAC-8, "Intake Sensor" . |

COMPONENT PARTS

< SYSTEM DESCRIPTION >

[AUTOMATIC AIR CONDITIONING]

| No. | Component | Description |
|-----|--------------------------|---|
| 11. | Air mix door motor RH | Refer to HAC-8, "Air Mix Door Motor RH" . |
| 12. | Fuse block (J/B) | Located in the passenger compartment, behind the left lower IP, the fuse block (J/B) contains the front blower motor relay and several fuses required for the air conditioner control system. |
| 13. | Front blower motor relay | The front blower motor relay controls the flow of current to fuse 17 and 27 in the fuse block (J/B). The relay is connected directly to ground, and is controlled by the BCM. |
| 14. | A/C switch assembly | A/C control operation signal is transmitted from the A/C switch assembly to the A/C auto amp. |

Intake Sensor

INFOID:0000000012876727

Intake sensor measures temperature of evaporator fin temperature. The sensor uses a thermistor which is sensitive to the change in temperature. The electrical resistance of the thermistor decreases as temperature increases.

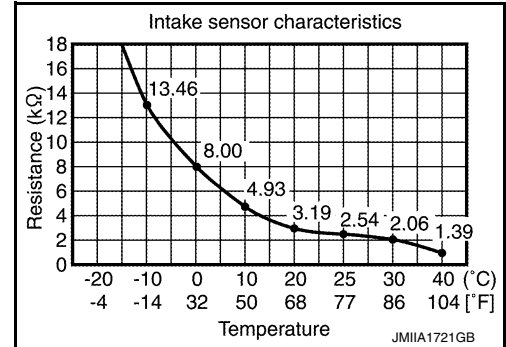

Air Mix Door Motor LH

INFOID:0000000012876728

- Air mix door motor (driver side) consists of motor that drives door, PBR (Potentio Balance Register) that detects door position and LCU (Local Control Unit) that perform multiplex communication control (LIN) with A/C auto amp. Refer to [HAC-16, "Door Control"](#).
- Rotation of motor is transmitted to air mix door (driver side) by link and lever. Air flow temperature is switched.

Air Mix Door Motor RH

INFOID:0000000012876729

- Air mix door motor (passenger side) consists of motor that drives door, PBR (Potentio Balance Register) that detects door position and LCU (Local Control Unit) that perform multiplex communication control (LIN) with A/C auto amp. Refer to [HAC-16, "Door Control"](#).
- Rotation of motor is transmitted to air mix door (passenger side) by link and lever. Air flow temperature is switched.

Mode Door Motor

INFOID:0000000012876730

- Mode door motor consists of motor that drives door, PBR (Potentio Balance Register) that detects door position and LCU (Local Control Unit) that perform multiplex communication control (LIN) with A/C auto amp. Refer to [HAC-16, "Door Control"](#).
- Rotation of motor is transmitted to mode door (ventilator door, foot door, and defroster door) by link and lever. Air outlet is switched.

Intake Door Motor

INFOID:0000000012876731

- Intake door motor consists of motor that drives door, PBR (Potentio Balance Register) that detects door position and LCU (Local Control Unit) that perform multiplex communication control (LIN) with A/C auto amp. Refer to [HAC-16, "Door Control"](#).
- Rotation of motor is transmitted to intake door by lever. Air inlet is switched.

COMPONENT PARTS

< SYSTEM DESCRIPTION >

[AUTOMATIC AIR CONDITIONING]

Front Blower Motor

INFOID:000000012876732

- The blower motor utilizes a brush-less motor with a rotating magnet.
- Quietness is improved over previous motors where the brush was the point of contact and the coil rotated.

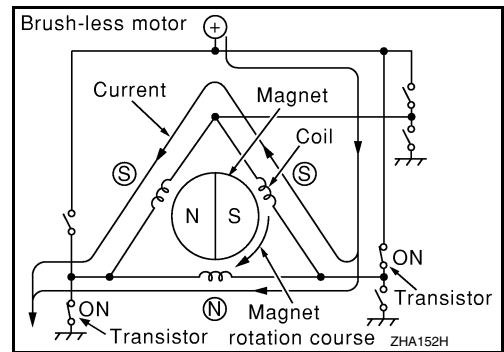
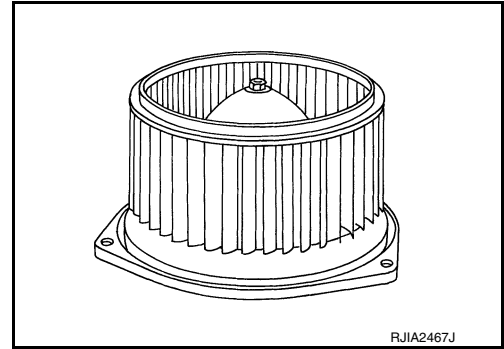

A/C Compressor

INFOID:000000012876733

Vaporized refrigerant is drawn into the A/C compressor from the evaporator, where it is compressed to a high pressure, high temperature vapor. The hot compressed vapor is then discharged to the condenser.

MAGNET CLUTCH

Description

Compressor is driven by the magnet clutch which is magnetized by electric power supply.

Structure and Operation

- Magnet clutch consists of pulley, clutch disc, and field coil.
- Pulley is connected with crankshaft pulley of engine via drive belt and is always rotated while engine is running.
- Clutch disc is connected with drive shaft of compressor.
- Field coil, which becomes a strong electric magnet when electricity is supplied, strongly pulls clutch disc and presses it to pulley.
- When A/C relay integrated in IPDM E/R turns ON, electricity is supplied to field coil, clutch disc is pressed to pulley, and engine rotational movement is transmitted from crankshaft pulley ⇒ drive belt ⇒ pulley ⇒ clutch disc ⇒ drive shaft. Compressor is operated.
- When A/C relay turns OFF, electricity is not supplied to field coil, and clutch disc is released from pulley. Compressor is not operated.

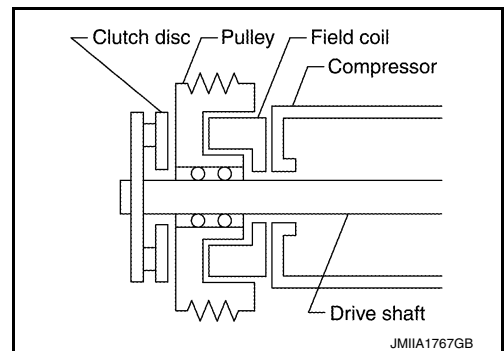

ECV (ELECTRICAL CONTROL VALVE)

ECV (electrical control valve) is installed on the compressor and controls emitting the appropriate amount of refrigerant when necessary.

COMPONENT PARTS

< SYSTEM DESCRIPTION >

[AUTOMATIC AIR CONDITIONING]

A/C Auto Amp.

INFOID:000000012876734

A/C auto amp. controls automatic air conditioning system by inputting and calculating signals from each sensor and each switch. A/C auto amp. has self-diagnosis function. Diagnosis of automatic air conditioning system can be performed quickly.

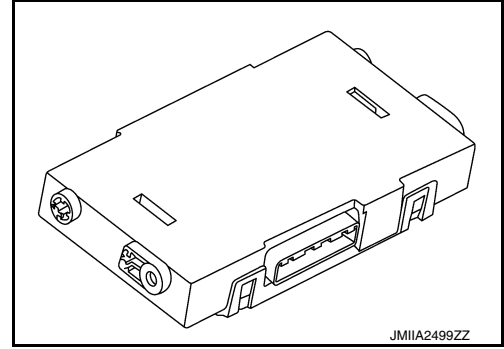

JMIIA2499ZZ

Ambient Sensor

INFOID:000000012876735

Ambient sensor measures ambient air temperature. The sensor uses a thermistor which is sensitive to the change in temperature. The electrical resistance of the thermistor decreases as temperature increases.

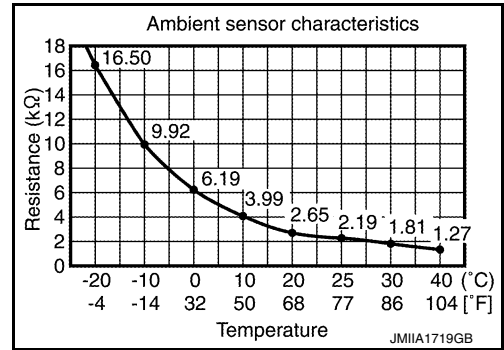

JMIIA1719GB

In-vehicle Sensor

INFOID:000000012876736

In-vehicle sensor measures temperature of intake air that flows through aspirator to passenger room. The sensor uses a thermistor which is sensitive to the change in temperature. The electrical resistance of the thermistor decreases as temperature increases.

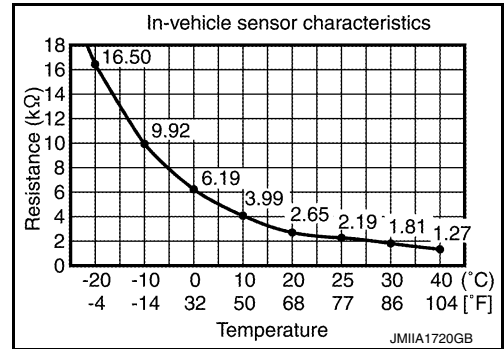

JMIIA1720GB

Sunload Sensor

INFOID:000000012876737

Sunload sensor measures sunload amount. This sensor converts sunload amount to voltage signal by photodiode and transmits to A/C auto amp.

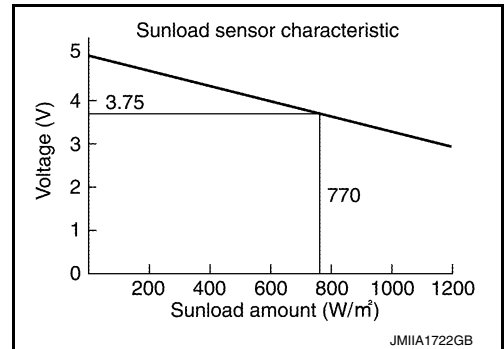

JMIIA1722GB

Refrigerant Pressure Sensor

INFOID:000000012876738

DESCRIPTION

COMPONENT PARTS

< SYSTEM DESCRIPTION >

[AUTOMATIC AIR CONDITIONING]

- The refrigerant pressure sensor converts high-pressure side refrigerant pressure into voltage and outputs it to ECM.
- ECM operates cooling system protection and idle speed control according to voltage value that is input.

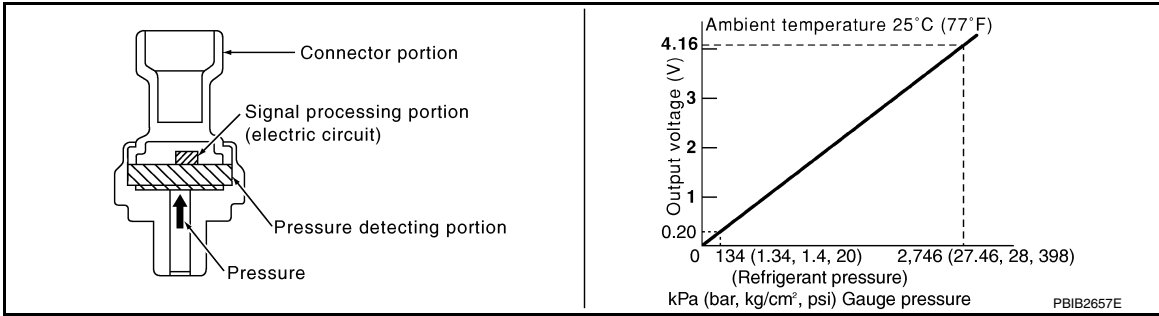

STRUCTURE AND OPERATION

- The refrigerant pressure sensor is a capacitance type sensor. It consists of a pressure detection area and a signal processing area.
- The pressure detection area, which is a variable capacity condenser, changes internal static capacitance according to pressure force.
- The signal processing area detects the static capacitance of the pressure detection area, converts the static capacitance into a voltage value, and transmits the voltage value to ECM.

A
B
C
D
E
F
G
H
J
K
L
M
N
O
P

HAC

SYSTEM

System Description

INFOID:000000012876739

SYSTEM DIAGRAM

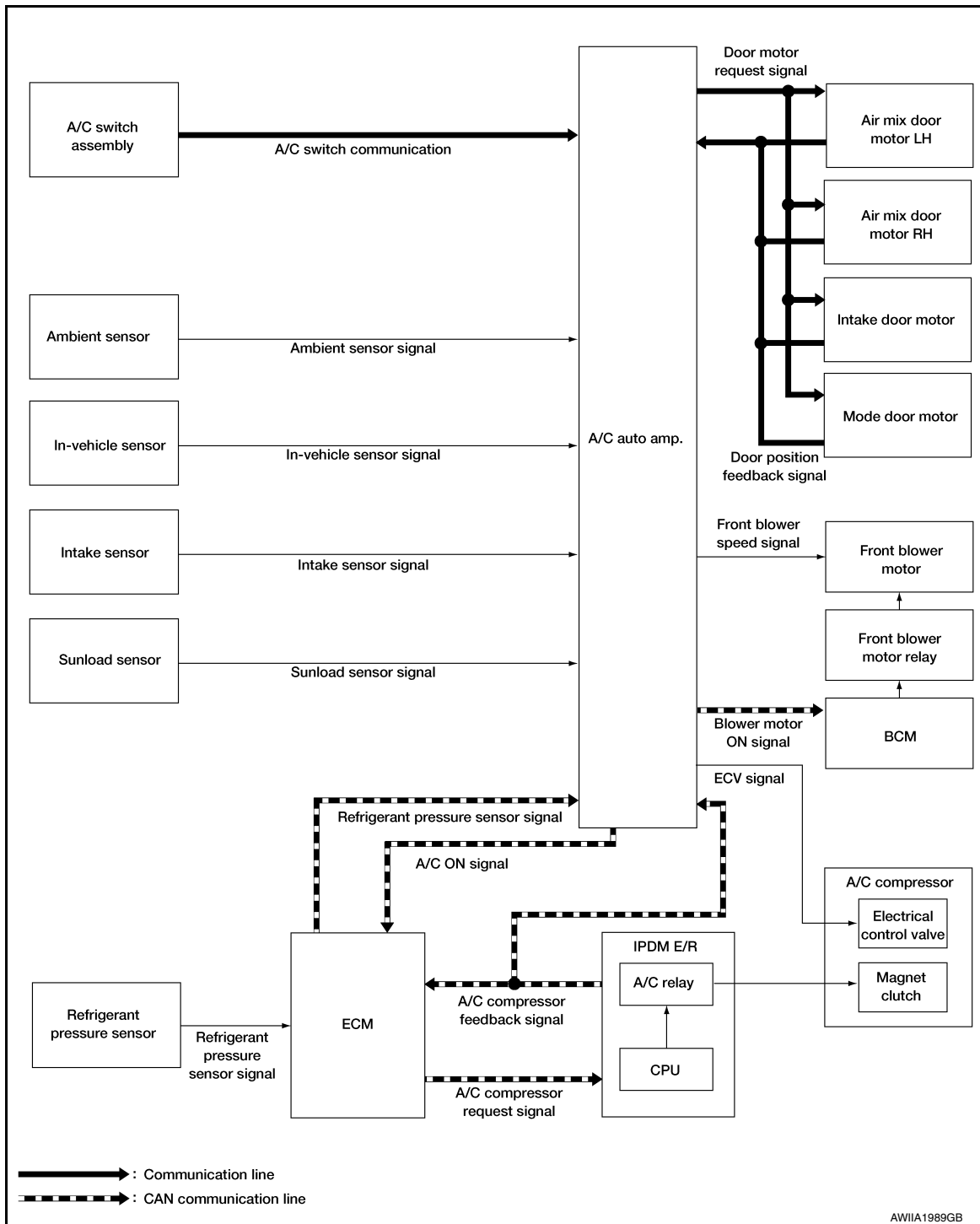

SYSTEM DESCRIPTION

- Automatic air conditioning system is controlled by each function of A/C auto amp., ECM, IPDM E/R and BCM.

Control by A/C auto amp.

- [HAC-13, "Air Flow Control"](#)
- [HAC-14, "Air Inlet Control"](#)
- [HAC-15, "Air Outlet Control"](#)

SYSTEM

[AUTOMATIC AIR CONDITIONING]

< SYSTEM DESCRIPTION >

- [HAC-15. "Compressor Control"](#)
- [HAC-16. "Door Control"](#)
- [HAC-18. "Temperature Control"](#)
- Correction for input value of each sensor

Ambient sensor (setting temperature correction)

- A/C auto amp. controls passenger room temperature so that the optimum level always matches the temperature level that the passenger may feel. Correction is applied to the target temperature that is set using temperature control dial, according to ambient temperature detected by ambient sensor.

In-vehicle sensor [in-vehicle temperature (front side) correction]

- Passenger room temperature (front side) detected by in-vehicle sensor is corrected for each front air conditioning control (driver side and passenger side).

Intake sensor (intake temperature correction)

- A/C auto amp. performs correction to change recognition intake temperature of A/C auto amp. quickly when difference is large between recognition intake temperature and intake temperature detected by intake temperature sensor. The correction is performed to change recognition intake temperature slowly when difference is small.

Sunload sensor (sunload amount correction)

- Sunload amount detected by sunload sensor is corrected for each air conditioning control.
- A/C auto amp. performs correction to change recognition sunload amount of A/C auto amp. slowly when sunload amount changes quickly, for example when entering or exiting a tunnel.

Control by ECM

- Cooling fan control
Refer to [EC-41. "COOLING FAN CONTROL : System Description"](#).
- Air conditioning cut control
Refer to [EC-39. "AIR CONDITIONING CUT CONTROL : System Description"](#).

Control by IPDM E/R

- Relay control
Refer to [PCS-7. "RELAY CONTROL SYSTEM : System Description"](#).
- Cooling fan control
Refer to [EC-41. "COOLING FAN CONTROL : System Description"](#).

Control by BCM

- Relay control
Refer to [BCS-6. "BODY CONTROL SYSTEM : System Description"](#).
- A/C switch assembly transmits the commands for automatic air conditioning system operation to A/C auto amp. via communication line. A/C auto amp. transmits each indication information to A/C switch assembly via communication line. A/C switch assembly displays each indication information that is received.

Air Flow Control

INFOID:0000000012876740

DESCRIPTION

- A/C auto amp. changes duty ratio of front blower motor drive signal and controls air flow continuously. When air flow is increased, duty ratio of front blower motor control signal gradually increases to prevent a sudden increase in air flow.
- In addition to manual control and automatic control, air flow control consists of starting fan speed control, low coolant temperature starting control, high in-vehicle temperature starting control and fan speed control at door motor operation

AUTOMATIC AIR FLOW CONTROL

- A/C auto amp. decides target air flow depending on target air mix door (front) opening angle.
- A/C auto amp. changes duty ratio of front blower motor control signal and controls the air flow continuously so that air flow matches the target air flow.

SYSTEM

< SYSTEM DESCRIPTION >

- When air outlet is VENT or B/L, the minimum air flow is changed depending on sunload.

[AUTOMATIC AIR CONDITIONING]

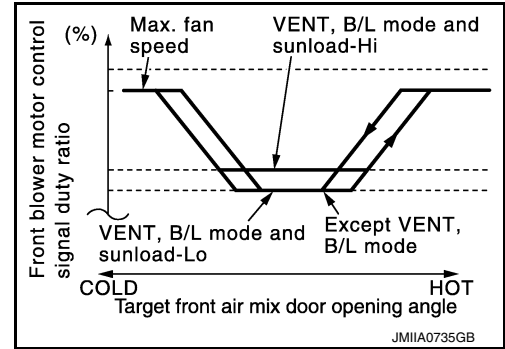

STARTING AIR FLOW CONTROL

- When front blower motor is activated, A/C auto amp. gradually increases duty ratio of front blower motor control signal to prevent a sudden increase in discharge air flow.
- It takes approximately 8 seconds for air flow to reach HI from LOW.

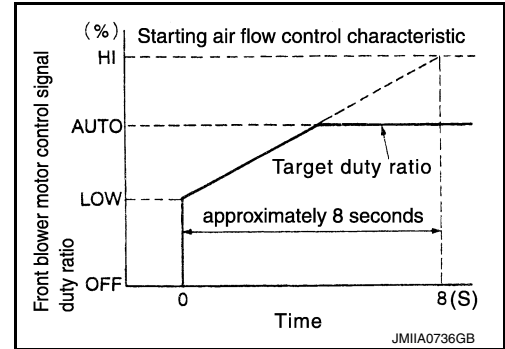

LOW COOLANT TEMPERATURE STARTING CONTROL

If the engine coolant temperature is 56°C (133°F) or less, to prevent a cold discharged air flow, A/C auto amp. suspends front blower motor activation for the maximum 150 seconds depending on target air mix door (front) opening angle. After this, front blower motor control signal is increased gradually, and front blower motor is activated.

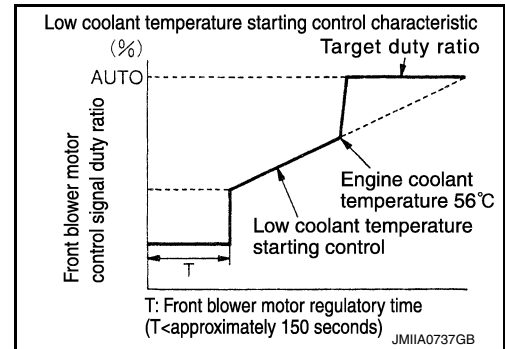

HIGH IN-VEHICLE TEMPERATURE STARTING CONTROL

When front evaporator fin temperature is high [intake sensor value is 35°C (95°F) or more], to prevent a hot discharged air flow, A/C auto amp. suspends front blower motor activation for approximately 3 seconds so that front evaporator is cooled by refrigerant.

FAN SPEED CONTROL AT DOOR MOTOR OPERATION

When mode door motor is activated while air flow is more than the specified value, A/C auto amp. reduces fan speed temporarily so that mode door moves smoothly.

Air Inlet Control

INFOID:000000012876741

The intake door is automatically controlled by the temperature setting, ambient temperature, in-vehicle temperature, intake temperature, amount of sunload and ON/OFF operation of the compressor. Intake door automatic control selects FRE, 20% FRE, or REC depending on a target air mix door opening angle, based on in-vehicle temperature, ambient temperature, and sunload.

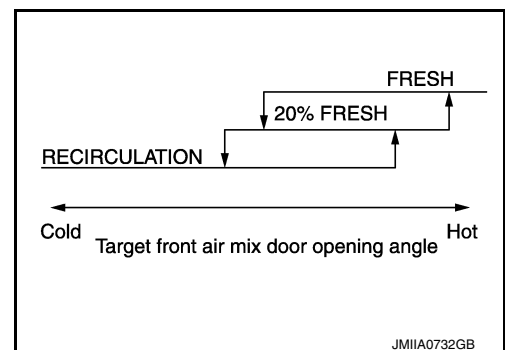

Air Outlet Control

INFOID:000000012876742

- While air outlet is in automatic control, A/C auto amp. selects the mode door position depending on a target air mix door angle and outlet air temperature calculated from sunload.
- If ambient temperature is excessively low, D/F is selected to prevent windshield fogging when air outlet is set to FOOT.

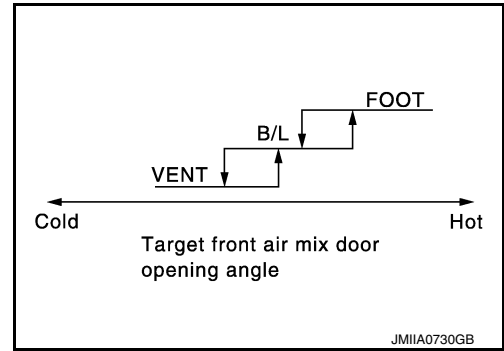

Compressor Control

INFOID:000000012876743

DESCRIPTION

- When the A/C compressor activation condition is satisfied while front blower motor is activated, A/C auto amp. transmits A/C ON signal and blower fan ON signal to ECM via CAN communication.
- ECM judges that the A/C compressor can be activated depending on each sensors state (refrigerant pressure sensor signal and others) and transmits A/C compressor request signal to IPDM E/R via CAN communication.
- IPDM E/R turns A/C relay ON and activates the A/C compressor depending on request from ECM.

COMPRESSOR PROTECTION CONTROL AT PRESSURE MALFUNCTION

When high-pressure side value that is detected by refrigerant pressure sensor is as per the following state, ECM requests IPDM E/R to turn A/C relay OFF and stops the A/C compressor.

- 3.12 MPa (31.82 kg/cm², 452.4 psi) or more (When the engine speed is less than 1,500 rpm)
- 2.74 MPa (27.95 kg/cm², 397.3 psi) or more (When the engine speed is 1,500 rpm or more)
- 0.14 MPa (1.43 kg/cm², 20.3 psi) or less

COMPRESSOR OIL CIRCULATION CONTROL

When the engine starts while the engine coolant temperature is 56°C (133°F) or less, ECM activates the A/C compressor for approximately 6 seconds and circulates the A/C compressor lubricant once.

LOW TEMPERATURE PROTECTION CONTROL

- When intake sensor detects that front evaporator fin temperature is 2.5°C (37°F) or less, A/C auto amp. requests ECM to turn A/C compressor OFF, and stops the A/C compressor.
- When the front evaporator fin temperature returns to 5.0°C (41°F) or more, the A/C compressor is activated.

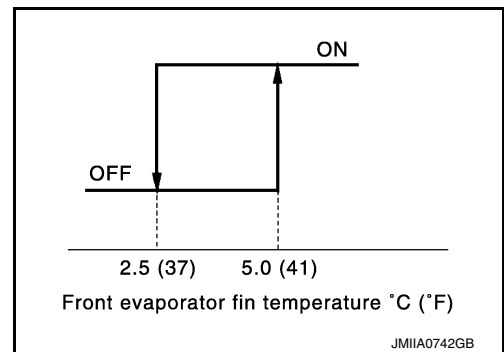

OPERATING RATE CONTROL

When set temperature is other than fully cold or air outlet is "VENT", "B/L" or "FOOT", A/C auto amp. controls the A/C compressor activation depending on ambient temperature.

AIR CONDITIONING CUT CONTROL

When engine is running in excessively high load condition, ECM requests IPDM E/R to turn A/C relay OFF, and stops the A/C compressor. Refer to [EC-39. "AIR CONDITIONING CUT CONTROL : System Description"](#) for details.

A
B
C
D
E
F
G
H
HAC
J
K
L
M
N
O
P

Door Control

INFOID:000000012876744

DOOR MOTOR CONTROL

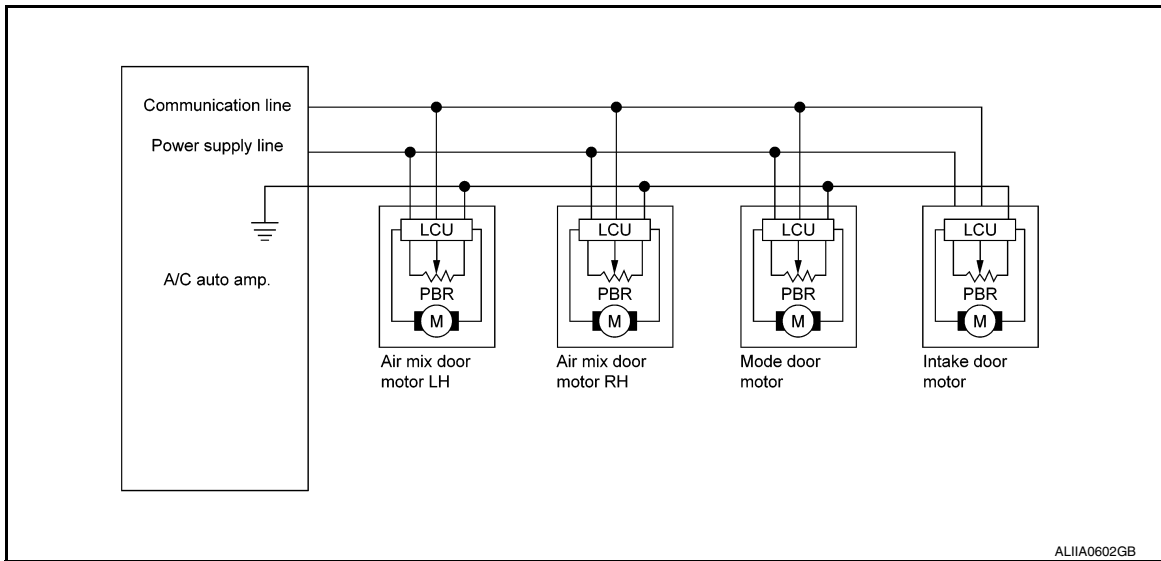

- LCU (Local Control Unit) is built into each door motor, and detects door position by PBR (Potentiometer Balance Resistor).
- A/C auto amp. communicates with each LCU via communication line and receives each door position feedback signal from each LCU.
- Each LCU controls each door to the appropriate position depending on the control signal from A/C auto amp.
- Each LCU transmits the signal of door movement completion to A/C auto amp., when the door movement is completed.

SWITCH AND THEIR CONTROL FUNCTION

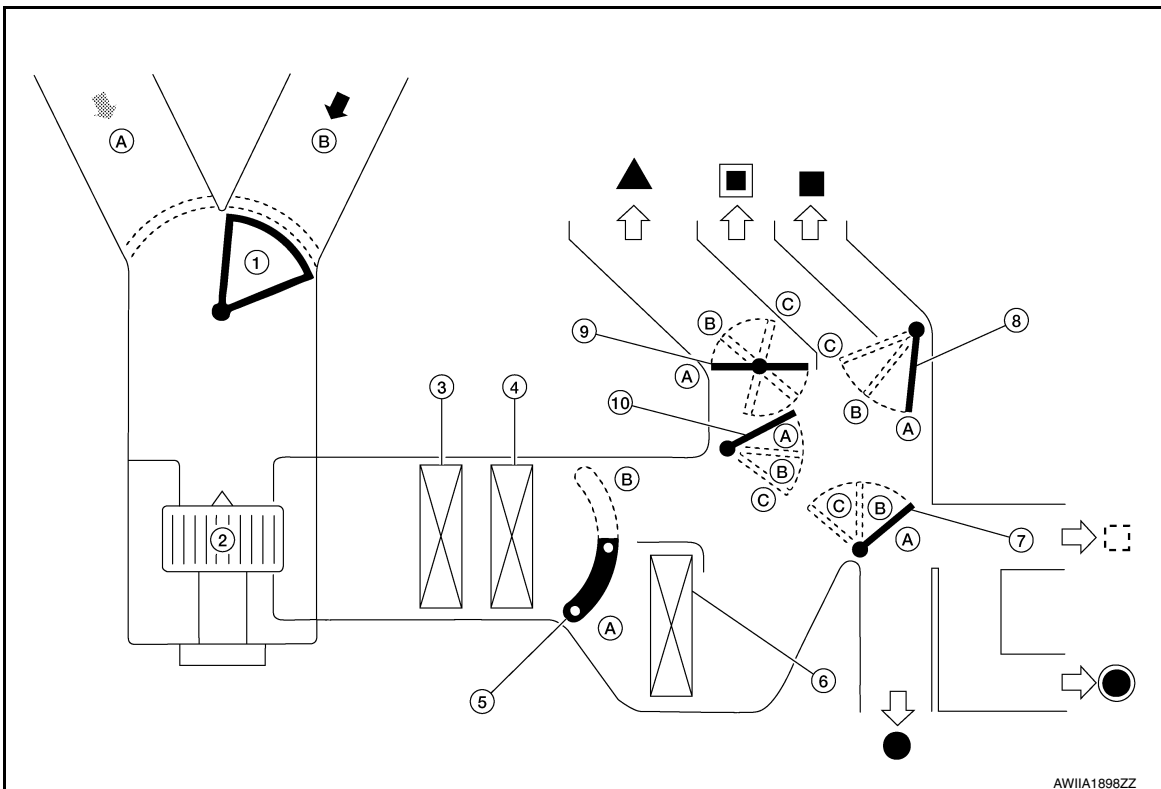

SYSTEM

< SYSTEM DESCRIPTION >

[AUTOMATIC AIR CONDITIONING]

- | | | |
|---------------------|-------------------------|-------------------------|
| 1. Intake door | 2. Front blower motor | 3. In-cabin microfilter |
| 4. Front evaporator | 5. Air mix door (front) | 6. Front heater core |
| 7. Foot door | 8. Ventilator door | 9. Defroster door |
| 10. Max. cool door | | |
-
- | | | |
|------------|-------------------|-----------------|
| Fresh air | Recirculation air | Discharge air |
| Defroster | Center ventilator | Side ventilator |
| Front foot | Rear foot | Rear ventilator |

| Switch position | | Door position | | | | | | |
|--------------------------------------|------------------|--------------------------------|----------------|----------------|-----------|-------------------------|--------------|----------------|
| | | Mode door | | | | Intake door | Air mix door | |
| | | Ventilator door | Max. cool door | Defroster door | Foot door | | Driver side | Passenger side |
| AUTO switch | | AUTO | | | | | | |
| MODE switch | | A | A | A | A | — | — | — |
| | | B | B | A | B | | | |
| | | C | C | B | B | | | |
| | | C | B | B | B | | | |
| DEF switch | | C | A | C | C | A | — | — |
| Intake switch* | | — | — | — | — | | | |
| Temperature control (Driver side) | DUAL switch: OFF | | | | | Full cold [18°C (60°F)] | — | — |
| | | 18.5°C – 31.5°C (61°F – 89 °F) | AUTO | | | | | |
| | | Full hot [32°C (90°F)] | B | | | | | |
| Temperature control (Driver side) | DUAL switch: ON | Full cold [18°C (60°F)] | — | — | — | — | A | — |
| | | 18.5°C – 31.5°C (61°F – 89 °F) | | | | | AUTO | |
| | | Full hot [32°C (90°F)] | | | | | B | |
| Temperature control (Passenger side) | DUAL switch: ON | Full cold [18°C (60°F)] | — | — | — | — | — | A |
| | | 18.5°C – 31.5°C (61°F – 89 °F) | | | | | | AUTO |
| | | Full hot [32°C (90°F)] | | | | | | B |
| ON-OFF switch | OFF | C | C | B | B | A | — | |

*: Inlet status is displayed by indicator during activation of automatic control

AIR DISTRIBUTION

SYSTEM

< SYSTEM DESCRIPTION >

[AUTOMATIC AIR CONDITIONING]

Discharge air flow

| MODE/DEF set position | Condition | Air outlet/distribution | | | | | |
|--------------------------|---------------------|-------------------------|------|------|-------|------|-----------|
| | | Ventilator | | | Foot | | Defroster |
| | | Center | Side | Rear | Front | Rear | |
| | DUAL switch: OFF | 44% | 44% | 12% | — | | — |
| | | 22% | 22% | 17% | 29% | 10% | — |
| | | — | 10% | 17% | 36% | 14% | 23% |
| | | — | 10% | 17% | 28% | 13% | 32% |
| | | — | 10% | 14% | — | | 76% |

Temperature Control

INFOID:000000012876745

- When ignition switch is in the ON position, A/C auto amp. always automatically controls temperature regardless of front air conditioning operational state.
- A/C auto amp. calculates the target air mix door opening angle depending on set temperature, in-vehicle temperature, ambient temperature, and sunload.
- Air mix door is controlled depending on the comparison of current air mix door opening angle and target air mix door opening angle.
- Regardless of in-vehicle temperature, ambient temperature, and sunload, air mix door is fixed at the fully cold position when set temperature is 18.0°C (60°F), and at the fully hot position when set temperature is 32.0°C (90°F).

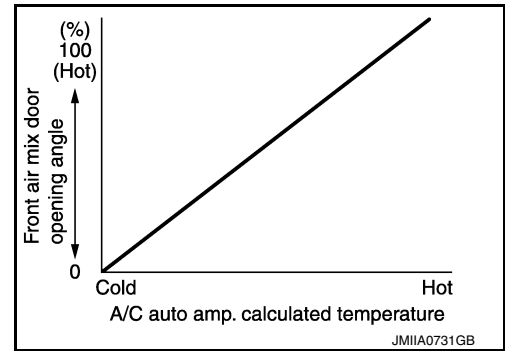

Fail-safe

INFOID:000000012876746

FAIL-SAFE FUNCTION

If a communication error exists between the A/C auto amp., and the A/C control switch for 30 seconds or longer, air conditioning is controlled under the following conditions:

When ambient temperature is less than 3°C (37°F) and engine coolant temperature is less than 56°C (133°F)

- Compressor** : ON
- Air outlet** : DEF
- Air inlet** : FRE (Fresh air intake)
- Blower fan speed** : AUTO
- Set temperature** : Setting before communication error occurs

When ambient temperature is 3°C (37°F) or more, or engine coolant temperature is 56°C (133°F) or more

- Compressor** : ON
- Air outlet** : AUTO
- Air inlet** : 20% FRE (20% fresh air intake)
- Blower fan speed** : AUTO
- Set temperature** : Setting before communication error occurs

OPERATION

Switch Name and Function

INFOID:000000012876747

Controller (A/C switch assembly)

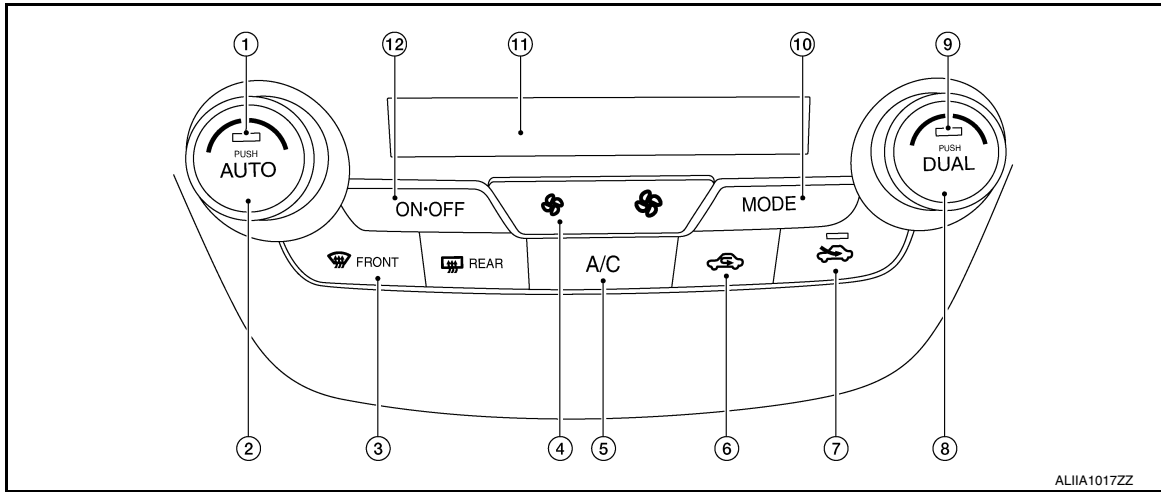

- | | | |
|---------------------|--|-------------------------|
| 1. AUTO switch | 2. Temperature control dial (driver side) | 3. Defroster switch |
| 4. Fan switch | 5. A/C switch | 6. Recirculation switch |
| 7. Fresh air switch | 8. Temperature control dial (passenger side) | 9. DUAL switch |
| 10. MODE switch | 11. Display | 12. ON-OFF switch |

Switch Operation

| | |
|------------------|--|
| AUTO switch | <p>Turns the switch indicator lamp and "AUTO" indicator on the display ON and then front air conditioning system becomes the following state:</p> <ul style="list-style-type: none"> • Air inlet: Automatic control • Air outlet: Automatic control • Blower fan: Automatic control • Compressor: ON |
| Defroster switch | <p>Turns defroster mode (switch indicator) between ON ⇔ OFF each time.</p> <p>When defroster switch is pressed while front air conditioning system is in the ON position.</p> <ul style="list-style-type: none"> • When defroster mode is turned ON, front air conditioning system becomes the following state. - Air inlet: Fresh air intake - Air outlet: DEF - Blower fan: Automatic control (If fan speed other than AUTO is selected before pressing defroster switch, fan speed is manual control.) - Compressor: ON • When defroster mode is turned OFF, front air conditioning system state returns to the previous state before defroster mode is selected. But, the following state is continued. - Air inlet: Fresh air intake - Compressor: ON <p>When defroster switch is pressed while front air conditioning system is in the OFF position.</p> <ul style="list-style-type: none"> • When defroster mode is turned ON, front air conditioning system becomes the following state. - Air inlet: Fresh air intake - Air outlet: Defroster - Blower fan: Automatic control - Compressor: ON • When defroster mode is turned OFF, entire front air conditioning system is set to auto mode. <p>NOTE: When defroster mode turns ON while front air conditioning system is in automatic control ("AUTO" is indicated), automatic control is released ("AUTO" turns OFF).</p> |

OPERATION

< SYSTEM DESCRIPTION >

[AUTOMATIC AIR CONDITIONING]

| | |
|---|---|
| DUAL switch | <ul style="list-style-type: none"> • Turns left and right ventilation temperature control (switch indicator) between ON ⇔ OFF each time. • When DUAL switch indicator is ON, the driver side and passenger side temperatures can each be set independently. • When DUAL switch indicator is OFF, the driver side outlet and setting temperature is applied to both sides. • Left and right ventilation temperature control is cancelled by turning the DEF mode ON. <p>NOTE: When front air conditioning system is in the OFF position, left and right ventilation temperature control can be selected only while front air conditioning system state (when MODE switch is pressed) is indicated on the display.</p> |
| Fan switch (UP/DOWN) | <p>Blower fan speed is manually controlled with these switches. Seven speeds are available for manual control (as shown on the display screen).</p> <p>NOTE:</p> <ul style="list-style-type: none"> • When fan switch is pressed while front air conditioning system is in OFF, front air conditioning system is activated. (Compressor control state returns to the previous state before front air conditioning system OFF.) • When fan switch is pressed while front air conditioning system is in automatic control ("AUTO" is indicated), automatic control is released ("AUTO" turns OFF). |
| A/C switch | <p>Compressor control (switch indicator) changes between ON ⇔ OFF each time this switch is pressed while front blower motor is operated.</p> <p>NOTE:</p> <ul style="list-style-type: none"> • A/C switch cannot be turned ON when front blower motor is OFF. • A/C switch cannot be turned OFF when air outlet is D/F or DEF. • Air inlet changes to fresh air intake when A/C switch is turned OFF while air inlet is set to recirculation. |
| MODE switch | <p>Selects air outlet sequentially from VENT ⇒ B/L ⇒ FOOT ⇒ D/F ⇒ VENT each time.</p> <p>NOTE:</p> <ul style="list-style-type: none"> • When front air conditioning system is in the OFF position, air outlet can be selected. • When MODE switch is pressed while front air conditioning system is in automatic control ("AUTO" is indicated), automatic control is released ("AUTO" turns OFF). |
| ON-OFF switch | <ul style="list-style-type: none"> • Turns front air conditioning system ON-OFF. • When front air conditioning system turns OFF: <ul style="list-style-type: none"> - air outlet becomes automatic control. - air inlet is set to recirculation. |
| Fresh air switch | <p>Air inlet changes to fresh air (FRE) when this switch is pressed.</p> <ul style="list-style-type: none"> • Fresh air switch indicator ON: Fresh air intake • Fresh air switch indicator OFF: Recirculation <p>NOTE: When front air conditioning system is in the OFF position, air inlet can be selected.</p> |
| Recirculation switch | <p>Air inlet changes to recirculation (REC) when this switch is pressed.</p> <ul style="list-style-type: none"> • Recirculation switch indicator ON: Recirculation • Recirculation switch indicator OFF: Fresh air intake <p>NOTE:</p> <ul style="list-style-type: none"> • When front air conditioning system is in the OFF position, air inlet can be selected. • When MODE switch and DEF switch is in the DEF position, air inlet cannot be selected to recirculation (REC). • When MODE switch and DEF switch is in the D/F position, air inlet can be selected to recirculation (REC). |
| Temperature control dial (Driver side) | <p>Setting temperature is selected using this dial within a range between 18°C (60°F) and 32°C (90°F) at a rate of 0.5°C (1.0°F) per adjustment.</p> <p>NOTE: When air conditioning system is OFF, setting temperature can be selected only while air conditioning system status screen [only when MODE switch (driver side) is pressed] is indicated on display.</p> |
| Temperature control dial (Passenger side) | <ul style="list-style-type: none"> • Outlet air flow temperature of passenger side can be changed without changing outlet air flow temperature of driver side. • Setting temperature is selected using this dial within a range between 18°C (60°F) and 32°C (90°F) at a rate of 0.5°C (1.0°F) per adjustment. <p>NOTE:</p> <ul style="list-style-type: none"> • When air conditioning system is OFF, setting temperature can be selected only while air conditioning system status screen [only when MODE switch (passenger side) is pressed] is indicated on display. • When DEF mode is ON, temperature control dial (passenger side) is inoperative. |

DIAGNOSIS SYSTEM (HVAC)

< SYSTEM DESCRIPTION >

[AUTOMATIC AIR CONDITIONING]

DIAGNOSIS SYSTEM (HVAC)

Description

INFOID:000000012876748

Air conditioning system performs self-diagnosis, operation check, function diagnosis, and various settings using diagnosis function of each control unit.

| ECU | Diagnostic item (CONSULT) | |
|---------------|---------------------------|------------------------|
| A/C auto amp. | ⓂHVAC | Self Diagnostic Result |
| | | Data Monitor |
| | | Active Test |
| | | Work support |
| ECM | ⓂENGINE | Self Diagnostic Result |
| | | Data Monitor |
| IPDM E/R | ⓂIPDM E/R | Self Diagnostic Result |
| | | Data Monitor |
| | | Auto active test |

CONSULT Function

INFOID:000000012876749

CONSULT performs the following functions via CAN communication with A/C auto amp.

APPLICATION ITEMS

| Diagnostic mode | Description |
|------------------------|---|
| Self Diagnostic Result | Displays the diagnosis results judged by A/C auto amp. |
| Data Monitor | Displays the input/output signal of A/C auto amp. |
| Active Test | The signals used to activate each device are forcibly supplied from A/C auto amp. |
| Work support | Changes the setting for each setting function. |
| ECU Identification | Displays the part number of A/C auto amp. |

NOTE:

Diagnosis should be performed with engine running. Door motor operation speeds become slower and no results may be returned even for normal operation if battery voltage drops below 12 V during self-diagnosis.

SELF-DIAGNOSIS RESULTS

Refer to [HAC-26. "DTC Index"](#).

ACTIVE TEST

| Test item | Description |
|-----------|--|
| HVAC TEST | The operation check of air conditioning system can be performed by selecting the mode. Refer to the following table for the conditions of each mode. |

Check each output device

| | Test item | | | | | | |
|--|-----------|-----------|-----------|----------|----------|----------|----------|
| | MODE 1 | MODE 2 | MODE 3 | MODE 4 | MODE 5 | MODE 6 | MODE 7 |
| Mode door motor (front) position | VENT | VENT | B/L | D/F1 | D/F2 | DEF | DEF |
| Intake door motor position | REC | REC | 20% FRE | FRE | FRE | FRE | FRE |
| Air mix door motor position | FULL COLD | FULL COLD | FULL COLD | FULL HOT | FULL HOT | FULL HOT | FULL HOT |
| Front blower motor control signal duty ratio | 30% | 30% | 60% | HI | HI | 60% | HI |

DIAGNOSIS SYSTEM (HVAC)

[AUTOMATIC AIR CONDITIONING]

< SYSTEM DESCRIPTION >

| | Test item | | | | | | |
|---------------|-----------|--------|--------|--------|--------|--------|--------|
| | MODE 1 | MODE 2 | MODE 3 | MODE 4 | MODE 5 | MODE 6 | MODE 7 |
| Magnet clutch | ON | ON | ON | OFF | OFF | ON | ON |
| ECV Duty | 100% | 100% | 50% | 0% | 0% | 100% | 100% |

NOTE:

Perform the inspection of each output device after starting the engine because the A/C compressor is operating.

DATA MONITOR

Display item list

| Monitor item [Unit] | Description |
|----------------------------------|--|
| AMB TEMP SEN [°C (°F)] | Ambient sensor value converted from ambient sensor signal received from ambient sensor. |
| IN-VEH TEMP [°C (°F)] | In-vehicle sensor value converted from in-vehicle sensor signal received from in-vehicle sensor. |
| INT TEMP SEN [°C (°F)] | Intake sensor value converted from intake sensor signal received from intake sensor. |
| SUNLOAD SEN [w/m ²] | Sunload sensor value converted from sunload sensor signal received from sunload sensor. |
| AMB SEN CAL [°C (°F)] | Ambient temperature value calculated by A/C auto amp. |
| IN-VEH CAL [°C (°F)] | In-vehicle temperature value calculated by A/C auto amp. |
| INT TEMP CAL [°C (°F)] | Front evaporator fin temperature value calculated by A/C auto amp. |
| SUNL SEN CAL [w/m ²] | Sunload value calculated by A/C auto amp. |
| COMP REQ SIG [On/Off] | Displays A/C ON signal ON/OFF status transmitted to other units via CAN communication. |
| FAN REQ SIG [On/Off] | Displays front blower motor ON/OFF status transmitted to other units via CAN communication. |
| FAN DUTY | Duty ratio of front blower motor judged by A/C auto amp. |
| XM | Target discharge front air temperature (driver side) judged by A/C auto amp. depending on the temperature setting and the value from each sensor. |
| PA TARGET A/TEMP | Target discharge front air temperature (passenger side) judged by A/C auto amp. depending on the temperature setting and the value from each sensor. |
| ENG COOL TEMP [°C (°F)] | Engine coolant temperature signal value received from ECM via CAN communication. |
| VEHICLE SPEED [km/h (mph)] | Vehicle speed signal value received from combination meter via CAN communication. |

WORK SUPPORT

| Work item | Description | Refer to |
|------------------|---|---|
| TEMP SET CORRECT | Setting change of temperature setting trimmer (front) can be performed. | HAC-43. "Temperature Setting Trimmer (Front)" |
| REC MEMORY SET | Setting change of inlet port memory function (REC) can be performed. | HAC-44. "Inlet Port Memory Function (REC)" |
| FRE MEMORY SET | Setting change of inlet port memory function (FRE) can be performed. | HAC-44. "Inlet Port Memory Function (FRE)" |
| BLOW SET | Setting change of foot position setting trimmer can be performed. | HAC-43. "Foot Position Setting Trimmer" |

NOTE:

When the battery cable is disconnected from the negative terminal or when the battery voltage becomes 10 V or less, the setting of WORK SUPPORT may be cancelled.

ECU DIAGNOSIS INFORMATION

A/C AUTO AMP.

Reference Value

INFOID:0000000012876750

VALUES ON THE DIAGNOSIS TOOL

| Monitor item | Condition | | Value/Status |
|------------------|--------------------------------------|---|---|
| AMB TEMP SEN | Ignition switch ON | — | Equivalent to ambient temperature |
| IN-VEH TEMP | Ignition switch ON | — | Equivalent to in-vehicle temperature (front side) |
| INT TEMP SEN | Ignition switch ON | — | Equivalent to front evaporator fin temperature |
| SUNLOAD SEN | Ignition switch ON | — | Equivalent to sunload (driver side) |
| AMB SEN CAL | Ignition switch ON | — | Equivalent to ambient temperature |
| IN-VEH CAL | Ignition switch ON | — | Equivalent to in-vehicle temperature (front side) |
| INT TEMP CAL | Ignition switch ON | — | Equivalent to front evaporator fin temperature |
| SUNL SEN CAL | Ignition switch ON | — | Equivalent to sunload (driver side) |
| COMP REQ SIG | Engine: Run at idle after warming up | A/C switch: ON (Compressor operation status ON) | On |
| | | A/C switch: OFF (Compressor operation status OFF) | Off |
| FAN REQ SIG | Engine: Run at idle after warming up | Front blower motor: ON | On |
| | | Front blower motor: OFF | Off |
| FAN DUTY | Engine: Run at idle after warming up | Front blower motor: ON | 25 – 81 |
| | | Front blower motor: OFF | 0 |
| XM | Ignition switch ON | — | Value according to target air flow temperature (driver side) |
| PA TARGET A/TEMP | Ignition switch ON | — | Value according to target air flow temperature (passenger side) |
| ENG COOL TEMP | Ignition switch ON | — | Equivalent to engine coolant temperature |
| VEHICLE SPEED | Driving | — | Equivalent to speedometer reading |

A
B
C
D
E
F
G
H
HAC
J
K
L
M
N
O
P

A/C AUTO AMP.

< ECU DIAGNOSIS INFORMATION >

[AUTOMATIC AIR CONDITIONING]

TERMINAL LAYOUT

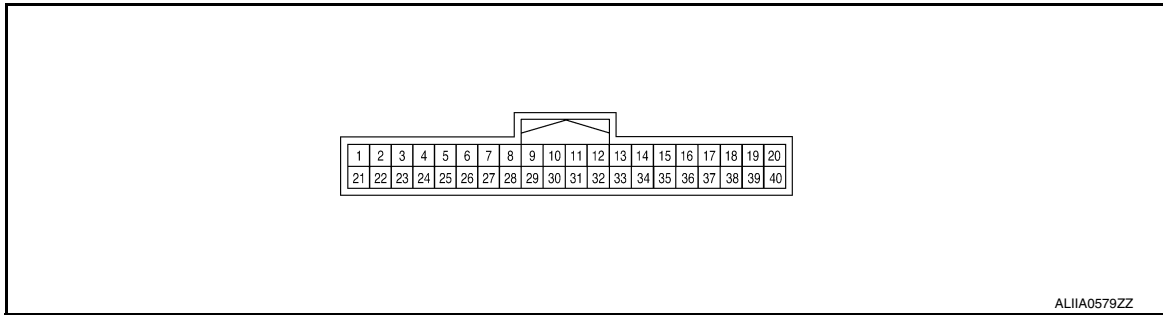

PHYSICAL VALUES

| Terminal No. (Wire color) | | Description | | Condition | Value (Approx.) | |
|------------------------------|--------|--|------------------|--------------------------|--|-----------------|
| + | - | Signal name | Input/ Output | | | |
| 1 (L) | — | CAN high | Input/ Output | — | — | |
| 2 (B) | — | Ground | — | — | — | |
| 3 (G) | Ground | Battery power supply | Input | Ignition switch OFF | Battery voltage | |
| 4 (BR) | Ground | Communication signal (A/C auto amp.→A/C switch assembly) | Output | Ignition switch ON | <p style="text-align: right; font-size: small;">SJIA1521J</p> | |
| 7 (L) | Ground | Ambient sensor signal | Input | Ignition switch ON | 0 – 4.8 V Output voltage varies with ambient temperature | |
| 8*1 (G) | Ground | Heated steering wheel switch signal | Input | Ignition switch ON | Heated steering wheel switch: While pressing | 0 V |
| | | | | | Other than the above | Battery voltage |
| 9 (LG) | Ground | Sunload sensor signal | Input | Ignition switch ON | 0 – 4.8 V Output voltage varies with sunload amount | |
| 13 (P) | Ground | IGN 2 | Input | Ignition switch ON | Battery voltage | |
| 15 (Y) | Ground | Rear window defogger switch | Output | Ignition switch ON | ON | 0 V |
| | | | | | OFF | 5 V |
| 16 (G) | Ground | Each door motor LIN signal | Input/ Output | Ignition switch ON | <p style="text-align: right; font-size: small;">SJIA1453J</p> | |

A/C AUTO AMP.

< ECU DIAGNOSIS INFORMATION >

[AUTOMATIC AIR CONDITIONING]

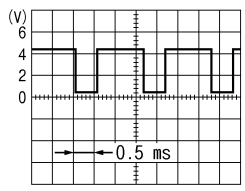
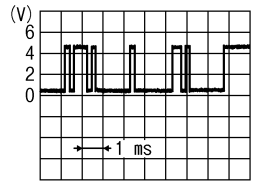
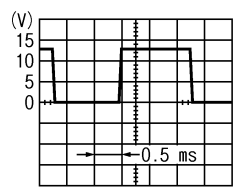
| Terminal No. (Wire color) | | Description | | Condition | Value (Approx.) |
|------------------------------|--------|---|------------------|---|---|
| + | - | Signal name | Input/ Output | | |
| 17 (W) | Ground | Each door motor power supply | Output | Ignition switch ON | Battery voltage |
| 18 (W) | Ground | Front blower motor control signal | Output | <ul style="list-style-type: none"> Ignition switch ON Front fan speed: 1st speed (manual) |  <p style="text-align: right; font-size: small;">JSIIA0096ZZ</p> |
| 20*1 (BR) | Ground | Heated steering wheel relay control signal | Output | Ignition switch ON | 0 V |
| | | | | Other than the above | Battery voltage |
| 21 (P) | — | CAN low | Input/ Output | — | — |
| 22 (B) | — | Ground | — | — | — |
| 23 (LG) | Ground | Ignition power supply | Input | Ignition switch ON | Battery voltage |
| 24 (V) | Ground | Communication signal (A/C switch assembly→A/C auto amp.) | Input | Ignition switch ON |  <p style="text-align: right; font-size: small;">SJIA1522J</p> |
| 26 (W) | — | Sensor ground | — | — | — |
| 27 (Y) | Ground | In-vehicle sensor signal | Input | Ignition switch ON | 0 – 4.8 V Output voltage varies with in-vehicle temperature |
| 28 (P) | Ground | Intake sensor signal | Input | Ignition switch ON | 0 – 4.8 V Output voltage varies with front evaporator fin temperature |
| 35 (P) | Ground | Rear window defogger feedback | Input | Ignition switch ON | Battery voltage |
| | | | | Rear defogger: OFF | 0 V |
| 37 (B) | — | Ground | — | — | — |
| 40 (G) | Ground | ECV (electrical control valve) control signal | Output | <ul style="list-style-type: none"> Ignition switch ON Active test (HVAC test): MODE 1 |  <p style="text-align: right; font-size: small;">SJIA1607E</p> |

A
B
C
D
E
F
G
H
HAC
J
K
L
M
N
O
P

A/C AUTO AMP.

< ECU DIAGNOSIS INFORMATION >

[AUTOMATIC AIR CONDITIONING]

*1: With heated steering wheel

Fail-safe

INFOID:000000012876751

FAIL-SAFE FUNCTION

If a communication error exists between the A/C auto amp., and the AV control unit and preset switch for 30 seconds or longer, air conditioning is controlled under the following conditions:

When ambient temperature is less than 3°C (37°F) and engine coolant temperature is less than 56°C (133°F)

Compressor : ON
Air outlet : DEF
Air inlet : FRE (Fresh air intake)
Blower fan speed : AUTO
Set temperature : Setting before communication error occurs

When ambient temperature is 3°C (37°F) or more, or engine coolant temperature is 56°C (133°F) or more

Compressor : ON
Air outlet : AUTO
Air inlet : 20% FRE (20% fresh air intake)
Blower fan speed : AUTO
Set temperature : Setting before communication error occurs

DTC Index

INFOID:000000012876752

| DTC | Items (CONSULT screen terms) | Reference |
|---------------------|---------------------------------|---|
| U1000 | CAN COMM CIRCUIT | HAC-45, "DTC Description" |
| U1010 | CONTROL UNIT (CAN) | HAC-46, "DTC Description" |
| B2578 | IN-VEHICLE SENSOR | HAC-47, "DTC Description" |
| B2579 | IN-VEHICLE SENSOR | HAC-47, "DTC Description" |
| B257B | AMBIENT SENSOR | HAC-50, "DTC Description" |
| B257C | AMBIENT SENSOR | HAC-50, "DTC Description" |
| B2581 | INTAKE SENSOR | HAC-53, "DTC Description" |
| B2582 | INTAKE SENSOR | HAC-53, "DTC Description" |
| B2630 ^{*1} | SUNLOAD SENSOR | HAC-56, "DTC Description" |
| B2631 ^{*1} | SUNLOAD SENSOR | HAC-56, "DTC Description" |
| B2632 | DR AIR MIX DOOR MOT | HAC-59, "DTC Description" |
| B2633 | DR AIR MIX DOOR MOT | HAC-59, "DTC Description" |
| B2634 | PASS AIR MIX DOOR MOT | HAC-61, "DTC Description" |
| B2635 | PASS AIR MIX DOOR MOT | HAC-61, "DTC Description" |
| B2636 | DR VENT DOOR FAIL | HAC-63, "DTC Description" |
| B2637 | DR B/L1 DOOR FAIL | HAC-63, "DTC Description" |
| B2638 | DR D/F1 DOOR FAIL | HAC-63, "DTC Description" |
| B2639 | DR DEF DOOR FAIL | HAC-63, "DTC Description" |
| B263D | FRE DOOR FAIL | HAC-65, "DTC Description" |
| B263E | 20P FRE DOOR FAIL | HAC-65, "DTC Description" |
| B263F | REC DOOR FAIL | HAC-65, "DTC Description" |
| B2654 | DR D/F2 DOOR FAIL | HAC-63, "DTC Description" |
| B2655 | DR B/L2 DOOR FAIL | HAC-63, "DTC Description" |

A/C AUTO AMP.

< ECU DIAGNOSIS INFORMATION >

[AUTOMATIC AIR CONDITIONING]

| DTC | Items (CONSULT screen terms) | Reference |
|-------|---------------------------------|---|
| B2796 | COMMUNICATION ERROR | HAC-67. "DTC Description" |
| B27B0 | A/C AUTO AMP. | HAC-69. "DTC Description" |

*1: Perform self-diagnosis under sunshine. When performing indoors, aim a light (more than 60 W) at sunload sensor, otherwise self-diagnosis indicates even though the sunload sensor is functioning normally.

NOTE:

If all of door motor DTCs (B2632, B2633, B2634, B2635, B2636, B2637, B2638, B2639, B263D, B263E, B263F, B2654 and B2655) are detected, check door motor communication circuit. Refer to [HAC-77. "Diagnosis Procedure"](#).

A
B
C
D
E
F
G
H
J
K
L
M
N
O
P

HAC

ECM, IPDM E/R, BCM

< ECU DIAGNOSIS INFORMATION >

[AUTOMATIC AIR CONDITIONING]

ECM, IPDM E/R, BCM

List of ECU Reference

INFOID:000000012876753

| ECU | Reference |
|----------|---|
| ECM | EC-84, "Reference Value" |
| | EC-102, "Fail-safe" |
| | EC-104, "DTC Inspection Priority Chart" |
| | EC-105, "DTC Index" |
| IPDM E/R | PCS-13, "Reference Value" |
| | PCS-20, "Fail Safe" |
| | PCS-21, "DTC Index" |
| BCM | BCS-30, "Reference Value" |
| | BCS-50, "Fail Safe" |
| | BCS-51, "DTC Inspection Priority Chart" |
| | BCS-52, "DTC Index" |

AUTOMATIC AIR CONDITIONING SYSTEM

[AUTOMATIC AIR CONDITIONING]

< WIRING DIAGRAM >

WIRING DIAGRAM

AUTOMATIC AIR CONDITIONING SYSTEM

Wiring Diagram

INFOID:000000012876754

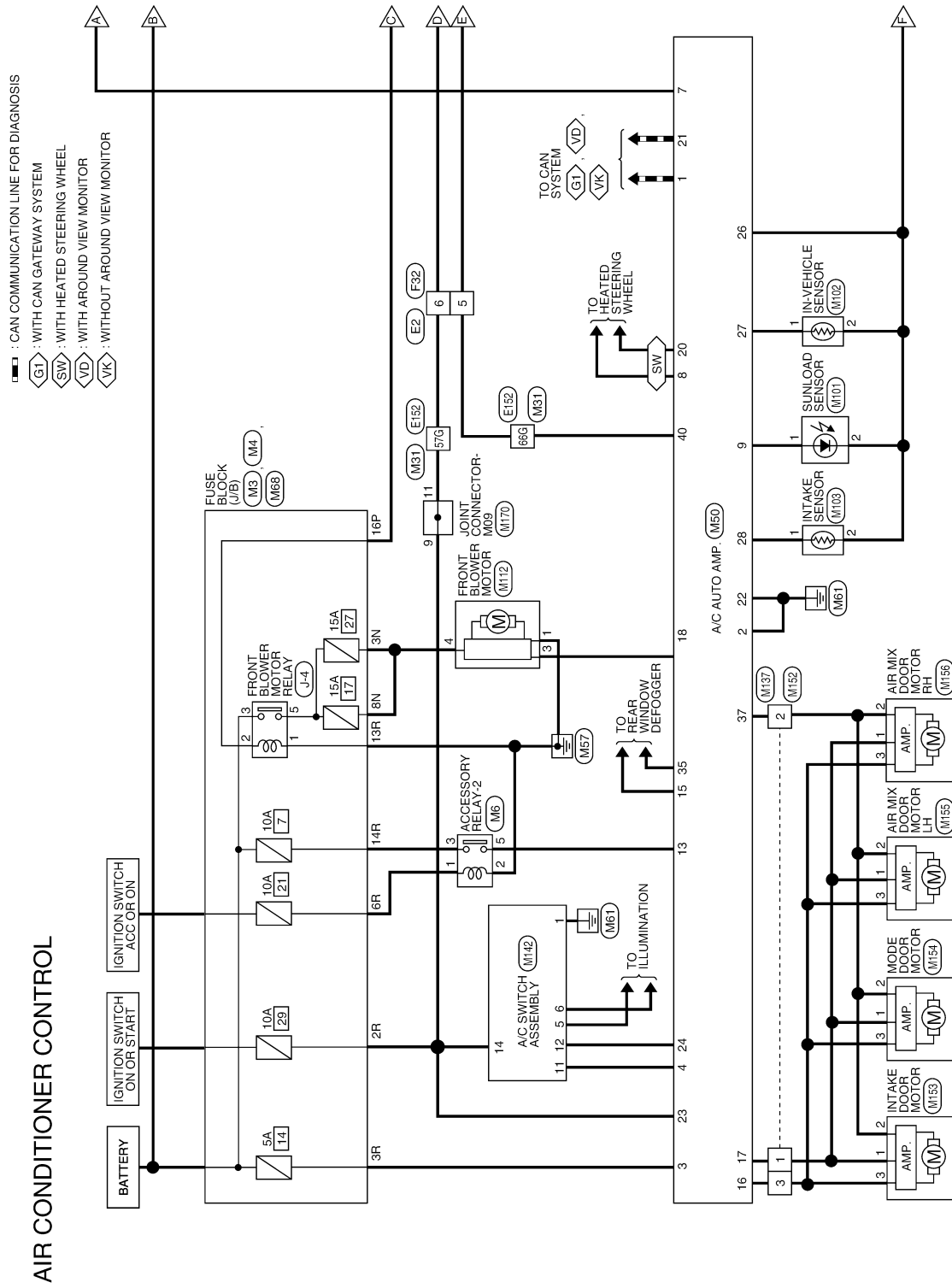

AAIWA0288GB

A
B
C
D
E
F
G
H
I
J
K
L
M
N
O
P

HAC

AUTOMATIC AIR CONDITIONING SYSTEM

< WIRING DIAGRAM >

[AUTOMATIC AIR CONDITIONING]

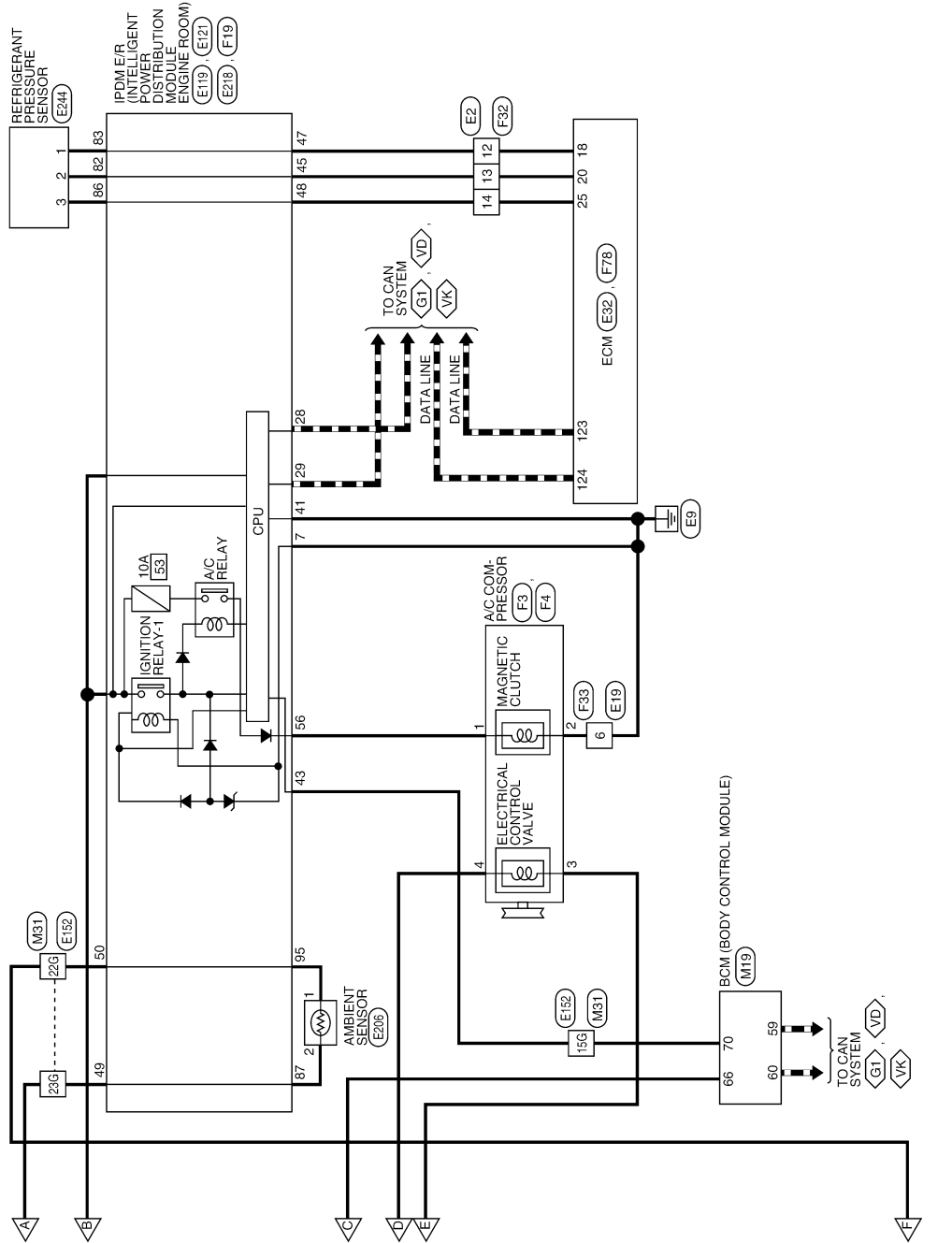

AAIWA0289GB

AUTOMATIC AIR CONDITIONING SYSTEM

[AUTOMATIC AIR CONDITIONING]

< WIRING DIAGRAM >

AIR CONDITIONER CONTROL CONNECTORS

| | |
|-----------------|------------------|
| Connector No. | M3 |
| Connector Name | FUSE BLOCK (J/B) |
| Connector Type | CS06FW-M2 |
| Connector Color | WHITE |

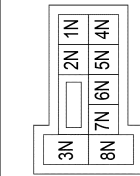

| Terminal No. | Color of Wire | Signal Name |
|--------------|---------------|-------------|
| 3N | L | - |
| 8N | L | - |

| | |
|-----------------|------------------|
| Connector No. | M4 |
| Connector Name | FUSE BLOCK (J/B) |
| Connector Type | NS16FW-CS |
| Connector Color | WHITE |

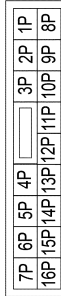

| Terminal No. | Color of Wire | Signal Name |
|--------------|---------------|-------------|
| 16P | W | - |

| | |
|-----------------|-------------------|
| Connector No. | M6 |
| Connector Name | ACCESSORY RELAY-2 |
| Connector Type | MS02FL-M2-LC |
| Connector Color | BLUE |



| Terminal No. | Color of Wire | Signal Name |
|--------------|---------------|-------------|
| 1 | L | - |
| 2 | B | - |

| | | |
|---|---|---|
| 3 | R | - |
| 5 | P | - |

| | |
|-----------------|---------------------------|
| Connector No. | M19 |
| Connector Name | BCM (BODY CONTROL MODULE) |
| Connector Type | TH40FB-NH |
| Connector Color | BLACK |

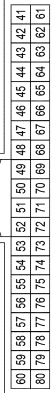

| Terminal No. | Color of Wire | Signal Name |
|--------------|---------------|----------------------|
| 59 | P | CAN-L |
| 60 | L | CAN-H |
| 66 | W | BLOWER FAN RELAY OUT |
| 70 | P | IGN USM OUT 1 |

| | |
|-----------------|-----------------|
| Connector No. | M31 |
| Connector Name | WIRE TO WIRE |
| Connector Type | TH80FW-CS16-TM4 |
| Connector Color | WHITE |

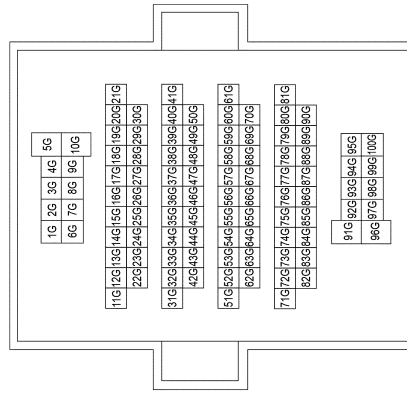

| Terminal No. | Color of Wire | Signal Name |
|--------------|---------------|-------------|
| 15G | P | - |
| 22G | W | - |

| | | |
|-----|----|---|
| 23G | L | - |
| 57G | LG | - |
| 66G | G | - |

| | |
|-----------------|---------------|
| Connector No. | M50 |
| Connector Name | A/C AUTO AMP. |
| Connector Type | TH40FW-NH |
| Connector Color | WHITE |

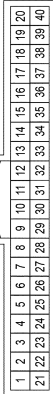

| Terminal No. | Color of Wire | Signal Name |
|--------------|---------------|--------------|
| 1 | L | CAN-H |
| 2 | B | GND |
| 3 | G | BATT |
| 4 | BR | Tx-FR |
| 7 | L | AMB SENS |
| 8 | G | STRG HTR SW |
| 9 | LG | SUN SENS |
| 13 | P | IGN2 |
| 15 | Y | RR DEF ON |
| 16 | G | ACTR (LIN) |
| 17 | W | VACTR |
| 18 | W | FR FAN PWM |
| 20 | BR | STRG HTR RLY |
| 21 | P | CAN-L |
| 22 | B | P-GND |
| 23 | LG | IGN |
| 24 | V | Rx TR |
| 26 | W | SENS GND |
| 27 | Y | INC SENS |
| 28 | P | INT SENS |
| 35 | P | RR DEF F/B |
| 37 | B | ACTR GND |
| 40 | G | EVC OUT |

A
B
C
D
E
F
G
H
HAC
J
K
L
M
N
O
P

AUTOMATIC AIR CONDITIONING SYSTEM

< WIRING DIAGRAM >

[AUTOMATIC AIR CONDITIONING]

| | |
|-----------------|--------------|
| Connector No. | M137 |
| Connector Name | WIRE TO WIRE |
| Connector Type | A03MW |
| Connector Color | WHITE |



| Terminal No. | Color of Wire | Signal Name |
|--------------|---------------|-------------|
| 1 | W | - |
| 2 | B | - |
| 3 | G | - |

| | |
|-----------------|---------------------|
| Connector No. | M142 |
| Connector Name | A/C SWITCH ASSEMBLY |
| Connector Type | TH16FW-NH |
| Connector Color | WHITE |

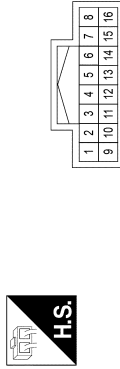

| Terminal No. | Color of Wire | Signal Name |
|--------------|---------------|-------------|
| 1 | B | GND |
| 5 | R | ILL+ |
| 6 | B | ILL- |
| 11 | BR | Rx |
| 12 | V | Tx |
| 14 | LG | - |

| | | |
|---|---|---|
| 1 | Y | - |
| 2 | W | - |

| | |
|-----------------|---------------|
| Connector No. | M103 |
| Connector Name | INTAKE SENSOR |
| Connector Type | C02FW |
| Connector Color | WHITE |

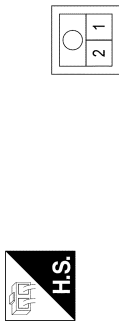

| Terminal No. | Color of Wire | Signal Name |
|--------------|---------------|-------------|
| 1 | P | - |
| 2 | W | - |

| | |
|-----------------|--------------------|
| Connector No. | M112 |
| Connector Name | FRONT BLOWER MOTOR |
| Connector Type | NS03FW-M3 |
| Connector Color | WHITE |

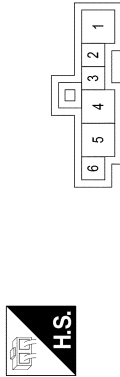

| Terminal No. | Color of Wire | Signal Name |
|--------------|---------------|-------------|
| 1 | B | - |
| 3 | W | - |
| 4 | L | - |

| | |
|-----------------|------------------|
| Connector No. | M68 |
| Connector Name | FUSE BLOCK (J/B) |
| Connector Type | NS16FBR-CS |
| Connector Color | BROWN |

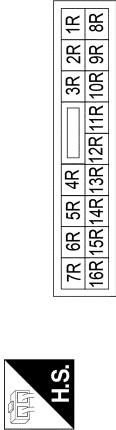

| Terminal No. | Color of Wire | Signal Name |
|--------------|---------------|-------------|
| 2R | LG | - |
| 3R | G | - |
| 6R | L | - |
| 13R | B | - |
| 14R | R | - |

| | |
|-----------------|----------------|
| Connector No. | M101 |
| Connector Name | SUNLOAD SENSOR |
| Connector Type | K02FB |
| Connector Color | BLACK |



| Terminal No. | Color of Wire | Signal Name |
|--------------|---------------|-------------|
| 1 | LG | - |
| 2 | W | - |

| | |
|-----------------|-------------------|
| Connector No. | M102 |
| Connector Name | IN-VEHICLE SENSOR |
| Connector Type | A02FW |
| Connector Color | WHITE |

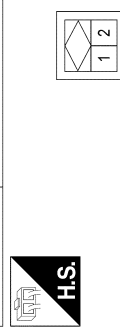

| Terminal No. | Color of Wire | Signal Name |
|--------------|---------------|-------------|
| | | |

AAIIA0786GB

AUTOMATIC AIR CONDITIONING SYSTEM

< WIRING DIAGRAM >

[AUTOMATIC AIR CONDITIONING]

| | |
|-----------------|---------------------|
| Connector No. | M170 |
| Connector Name | JOINT CONNECTOR-M09 |
| Connector Type | BJ30FW |
| Connector Color | WHITE |

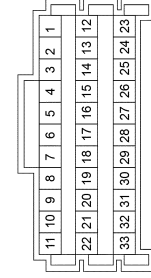

| Terminal No. | Color of Wire | Signal Name |
|--------------|---------------|-------------|
| 9 | LG | - |
| 11 | LG | - |

| | |
|-----------------|--------------|
| Connector No. | E2 |
| Connector Name | WIRE TO WIRE |
| Connector Type | TH16MW-NH |
| Connector Color | WHITE |



| Terminal No. | Color of Wire | Signal Name |
|--------------|---------------|-------------|
| 5 | P | - |
| 6 | R | - |
| 12 | Y | - |
| 13 | LG | - |
| 14 | V | - |

| | | |
|---|-----|---|
| 2 | B | - |
| 3 | L/W | - |

| | |
|-----------------|-----------------------|
| Connector No. | M155 |
| Connector Name | AIR MIX DOOR MOTOR LH |
| Connector Type | A03MW |
| Connector Color | WHITE |

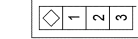

| Terminal No. | Color of Wire | Signal Name |
|--------------|---------------|-------------|
| 1 | L/R | - |
| 2 | B | - |
| 3 | L/W | - |

| | |
|-----------------|-----------------------|
| Connector No. | M156 |
| Connector Name | AIR MIX DOOR MOTOR RH |
| Connector Type | A03MW |
| Connector Color | WHITE |



| Terminal No. | Color of Wire | Signal Name |
|--------------|---------------|-------------|
| 1 | L/R | - |
| 2 | B | - |
| 3 | L/W | - |

| | |
|-----------------|--------------|
| Connector No. | M152 |
| Connector Name | WIRE TO WIRE |
| Connector Type | A03FW |
| Connector Color | WHITE |

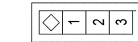

| Terminal No. | Color of Wire | Signal Name |
|--------------|---------------|-------------|
| 1 | L/R | - |
| 2 | B | - |
| 3 | L/W | - |

| | |
|-----------------|-------------------|
| Connector No. | M153 |
| Connector Name | INTAKE DOOR MOTOR |
| Connector Type | A03MW |
| Connector Color | WHITE |

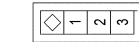

| Terminal No. | Color of Wire | Signal Name |
|--------------|---------------|-------------|
| 1 | L/R | - |
| 2 | B | - |
| 3 | L/W | - |

| | |
|-----------------|-----------------|
| Connector No. | M154 |
| Connector Name | MODE DOOR MOTOR |
| Connector Type | A03MW |
| Connector Color | WHITE |

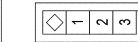

| Terminal No. | Color of Wire | Signal Name |
|--------------|---------------|-------------|
| 1 | L/R | - |

A
B
C
D
E
F
G
H
HAC
J
K
L
M
N
O
P

AAIIA0787GB

AUTOMATIC AIR CONDITIONING SYSTEM

< WIRING DIAGRAM >

[AUTOMATIC AIR CONDITIONING]

| | | |
|-----|----|---|
| 22G | G | - |
| 23G | BG | - |
| 57G | R | - |
| 86G | P | - |

| | |
|-----------------|----------------|
| Connector No. | E206 |
| Connector Name | AMBIENT SENSOR |
| Connector Type | RS02FB |
| Connector Color | BLACK |



| Terminal No. | Color of Wire | Signal Name |
|--------------|---------------|-------------|
| 1 | O | - |
| 2 | BR | - |

| | |
|-----------------|--|
| Connector No. | E218 |
| Connector Name | IPDM E/R (INTELLIGENT POWER DISTRIBUTION MODULE ENGINE ROOM) |
| Connector Type | TH16FW-NH |
| Connector Color | WHITE |

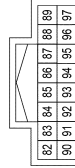

| Terminal No. | Color of Wire | Signal Name |
|--------------|---------------|------------------|
| 82 | W | PD SENS SIG-FEM |
| 83 | G | PD SENS PWR-FEM |
| 86 | B | PD SENS GND-FEM |
| 87 | BR | AMB SENS SIG-FEM |
| 95 | O | AMB SENS GND-FEM |

| | | |
|----|----|------------------|
| 43 | L | IGN SIGNAL |
| 45 | LG | PD SENS SIG-E/R |
| 47 | Y | PD SENS PWR-E/R |
| 48 | V | PD SENS GND-E/R |
| 49 | BG | AMB SENS SIG-E/R |
| 50 | G | AMB SENS GND-E/R |

| | |
|-----------------|--|
| Connector No. | E121 |
| Connector Name | IPDM E/R (INTELLIGENT POWER DISTRIBUTION MODULE ENGINE ROOM) |
| Connector Type | NS12FW-CS |
| Connector Color | WHITE |

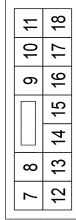

| Terminal No. | Color of Wire | Signal Name |
|--------------|---------------|-------------|
| 7 | B | P-GND |

| | |
|-----------------|-----------------|
| Connector No. | E152 |
| Connector Name | WIRE TO WIRE |
| Connector Type | TH80MW-CS16-TM4 |
| Connector Color | WHITE |

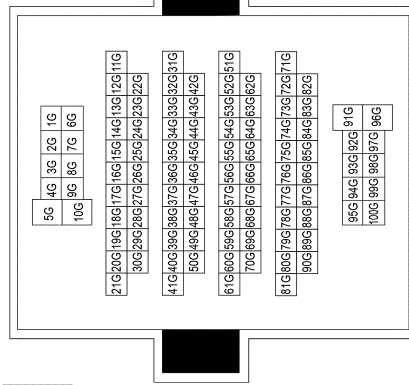

| Terminal No. | Color of Wire | Signal Name |
|--------------|---------------|-------------|
| 15G | L | - |

| | |
|-----------------|--------------|
| Connector No. | E119 |
| Connector Name | WIRE TO WIRE |
| Connector Type | NS08MBR-CS |
| Connector Color | BROWN |

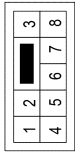

| Terminal No. | Color of Wire | Signal Name |
|--------------|---------------|-------------|
| 6 | GR | - |

| | |
|-----------------|-----------------|
| Connector No. | E32 |
| Connector Name | ECM |
| Connector Type | RH24FB-RZ8-L-LH |
| Connector Color | BLACK |

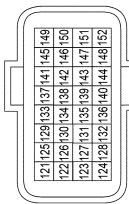

| Terminal No. | Color of Wire | Signal Name |
|--------------|---------------|-------------|
| 123 | P | CAN-L |
| 124 | L | CAN-H |

| | |
|-----------------|--|
| Connector No. | E119 |
| Connector Name | IPDM E/R (INTELLIGENT POWER DISTRIBUTION MODULE ENGINE ROOM) |
| Connector Type | TH32FW-NH |
| Connector Color | WHITE |

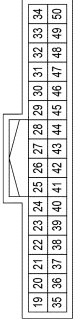

| Terminal No. | Color of Wire | Signal Name |
|--------------|---------------|-------------|
| 28 | P | CAN-L |
| 29 | L | CAN-H |
| 41 | B | S-GND |

AAIIA0788GB

AUTOMATIC AIR CONDITIONING SYSTEM

< WIRING DIAGRAM >

[AUTOMATIC AIR CONDITIONING]

| | |
|-----------------|--------------|
| Connector No. | F33 |
| Connector Name | WIRE TO WIRE |
| Connector Type | NS08FBR-CS |
| Connector Color | BROWN |

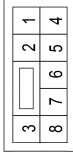

| | | | | | |
|--------------|---|---------------|---|-------------|---|
| Terminal No. | 6 | Color of Wire | B | Signal Name | - |
|--------------|---|---------------|---|-------------|---|

| | |
|-----------------|------------------|
| Connector No. | F78 |
| Connector Name | ECM |
| Connector Type | MAB39FB-MEB20-LH |
| Connector Color | BLACK |

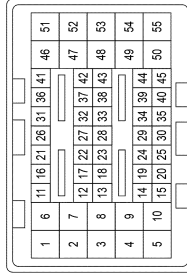

| | | | | | |
|--------------|----|---------------|---|-------------|--|
| Terminal No. | 18 | Color of Wire | Y | Signal Name | SENSOR POWER SUPPLY (ENGINE OIL PRESSURE SENSOR) |
| | 20 | LG | | | REFRIGERANT PRESSURE SENSOR |
| | 25 | V | | | SENSOR GROUND (REFRIGERANT PRESSURE SENSOR) |

| | | |
|-----------------|--|---|
| 4 | GR | - |
| Connector No. | F19 | |
| Connector Name | IPDM E/R (INTELLIGENT POWER DISTRIBUTION MODULE ENGINE ROOM) | |
| Connector Type | NS10FW-CS | |
| Connector Color | WHITE | |

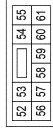

| | | | | | |
|--------------|----|---------------|---|-------------|----------|
| Terminal No. | 56 | Color of Wire | P | Signal Name | A/C COMP |
|--------------|----|---------------|---|-------------|----------|

| | |
|-----------------|--------------|
| Connector No. | F32 |
| Connector Name | WIRE TO WIRE |
| Connector Type | TH16FW-NH |
| Connector Color | WHITE |



| | | | | | |
|--------------|----|---------------|----|-------------|---|
| Terminal No. | 5 | Color of Wire | SB | Signal Name | - |
| | 6 | GR | | | - |
| | 12 | Y | | | - |
| | 13 | LG | | | - |
| | 14 | V | | | - |

| | |
|-----------------|-----------------------------|
| Connector No. | E244 |
| Connector Name | REFRIGERANT PRESSURE SENSOR |
| Connector Type | RK03FB |
| Connector Color | BLACK |



| | | | | | |
|--------------|---|---------------|---|-------------|---|
| Terminal No. | 1 | Color of Wire | G | Signal Name | - |
| | 2 | W | | | - |
| | 3 | B | | | - |

| | |
|-----------------|----------------|
| Connector No. | F3 |
| Connector Name | A/C COMPRESSOR |
| Connector Type | RH02FB |
| Connector Color | BLACK |



| | | | | | |
|--------------|---|---------------|---|-------------|---|
| Terminal No. | 1 | Color of Wire | P | Signal Name | - |
| | 2 | B | | | - |

| | |
|-----------------|----------------|
| Connector No. | F4 |
| Connector Name | A/C COMPRESSOR |
| Connector Type | RK02FGY |
| Connector Color | GRAY |



| | | | | | |
|--------------|---|---------------|----|-------------|---|
| Terminal No. | 3 | Color of Wire | SB | Signal Name | - |
|--------------|---|---------------|----|-------------|---|

AAIIA0789GB

A
B
C
D
E
F
G
H
HAC
J
K
L
M
N
O
P

DIAGNOSIS AND REPAIR WORK FLOW

< BASIC INSPECTION >

[AUTOMATIC AIR CONDITIONING]

BASIC INSPECTION

DIAGNOSIS AND REPAIR WORK FLOW

Work Flow

INFOID:0000000012876755

OVERALL SEQUENCE

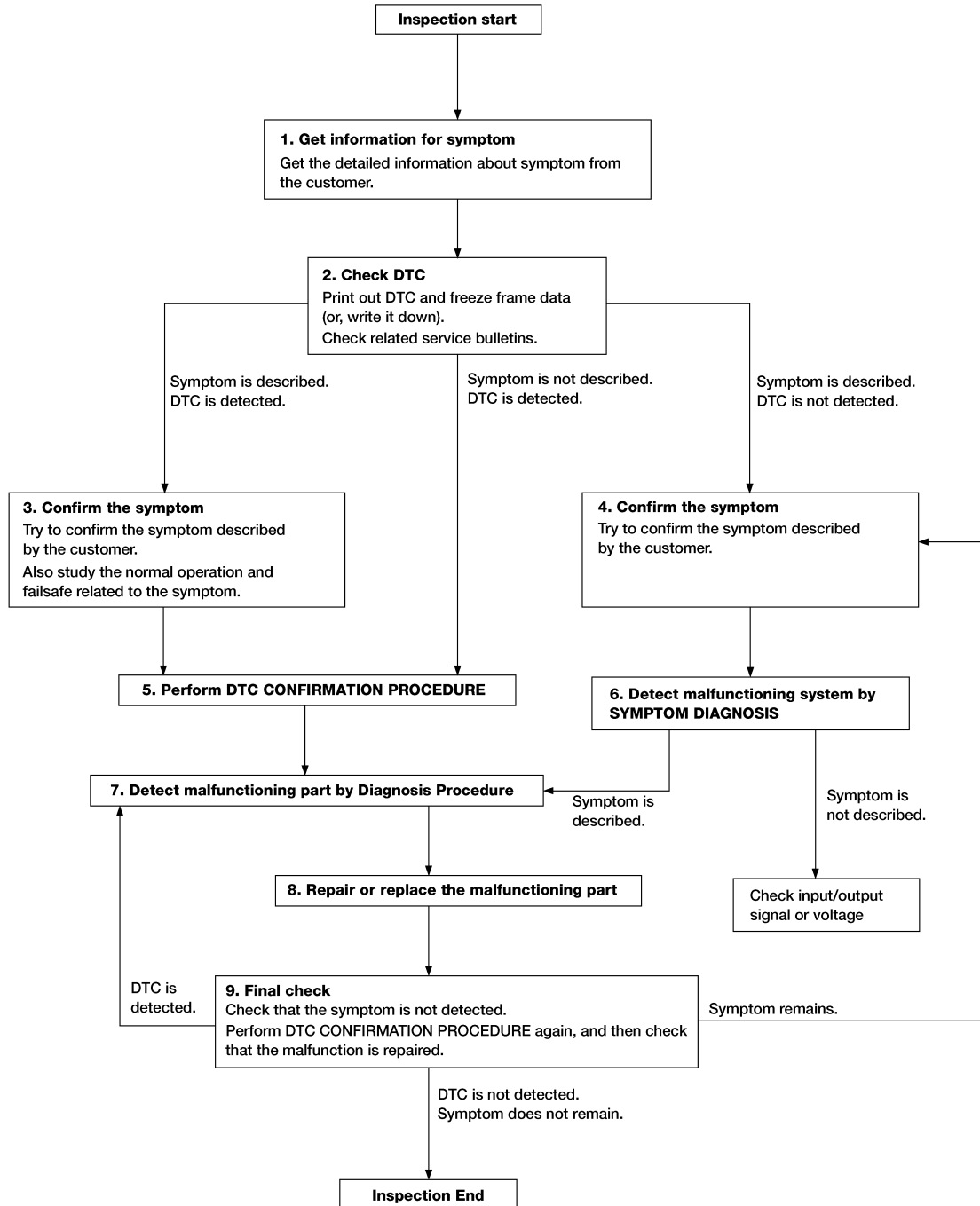

ALAI0158GB

DETAILED FLOW

Revision: December 2015

HAC-36

2016 Murano NAM

DIAGNOSIS AND REPAIR WORK FLOW

< BASIC INSPECTION >

[AUTOMATIC AIR CONDITIONING]

1. GET INFORMATION FOR SYMPTOM

1. Get detailed information from the customer about the symptom (the condition and the environment when the incident/malfunction occurs).
2. Check operation condition of the function that is malfunctioning.

>> GO TO 2.

2. CHECK DTC

1. Check DTC.
2. Perform the following procedure if DTC is detected.
 - Record DTC and freeze frame data (Print them out using CONSULT.)
 - Erase DTC.
 - Study the relationship between the cause detected by DTC and the symptom described by the customer.
3. Check related service bulletins for information.

Are any symptoms described and any DTC detected?

- Symptom is described, DTC is detected>>GO TO 3.
- Symptom is described, DTC is not detected>>GO TO 4.
- Symptom is not described, DTC is detected>>GO TO 5.

3. CONFIRM THE SYMPTOM

Try to confirm the symptom described by the customer.
Also study the normal operation and fail-safe related to the symptom.
Verify relation between the symptom and the condition when the symptom is detected.

>> GO TO 5.

4. CONFIRM THE SYMPTOM

Try to confirm the symptom described by the customer.
Verify relation between the symptom and the condition when the symptom is detected.

>> GO TO 6.

5. PERFORM DTC CONFIRMATION PROCEDURE

Perform DTC CONFIRMATION PROCEDURE for the detected DTC and then check that DTC is detected again. At this time, always connect CONSULT to the vehicle, and check self diagnostic results in real time. If two or more DTCs are detected, refer to DTC INSPECTION PRIORITY CHART, and determine trouble diagnosis order.

NOTE:

- Freeze frame data is useful if the DTC is not detected.
- Perform Component Function Check if DTC CONFIRMATION PROCEDURE is not included on Service Manual. This simplified check procedure is an effective alternative though DTC cannot be detected during this check.
If the result of Component Function Check is NG, it is the same as the detection of DTC by DTC CONFIRMATION PROCEDURE.

Is DTC detected?

- YES >> GO TO 7.
- NO >> Check according to [GI-42. "Intermittent Incident"](#).

6. DETECT MALFUNCTIONING SYSTEM BY SYMPTOM DIAGNOSIS

Detect malfunctioning system according to SYMPTOM DIAGNOSIS based on the confirmed symptom in step 4, and determine the trouble diagnosis order based on possible causes and symptom.

Is the symptom described?

- YES >> GO TO 7.
- NO >> Monitor input data from related sensors or check voltage of related module terminals using CONSULT.

7. DETECT MALFUNCTIONING PART BY DIAGNOSIS PROCEDURE

A

B

C

D

E

F

G

H

HAC

J

K

L

M

N

O

P

DIAGNOSIS AND REPAIR WORK FLOW

[AUTOMATIC AIR CONDITIONING]

< BASIC INSPECTION >

Inspect according to Diagnosis Procedure of the system.

Is malfunctioning part detected?

YES >> GO TO 8.

NO >> Check according to [GI-42. "Intermittent Incident"](#).

8. REPAIR OR REPLACE THE MALFUNCTIONING PART

1. Repair or replace the malfunctioning part.
2. Reconnect parts or connectors disconnected during Diagnosis Procedure again after repair and replacement.
3. Check DTC. If DTC is detected, erase it.

>> GO TO 9.

9. FINAL CHECK

When DTC is detected in step 2, perform DTC CONFIRMATION PROCEDURE again, then check that the malfunction is repaired.

When symptom is described by the customer, refer to confirmed symptom in step 3 or 4, and check that the symptom is not detected.

Is DTC detected and does symptom remain?

YES-1 >> DTC is detected: GO TO 7.

YES-2 >> Symptom remains: GO TO 4.

NO >> Before returning the vehicle to the customer, always erase DTC.

OPERATION INSPECTION

< BASIC INSPECTION >

[AUTOMATIC AIR CONDITIONING]

OPERATION INSPECTION

Work Procedure

INFOID:000000012876756

DESCRIPTION

The purpose of the operational check is to check that the individual system operates normally.

Check condition : Engine running at normal operating temperature.

OPERATION INSPECTION

1.CHECK MEMORY FUNCTION

1. Set temperature control (driver side) to 32.0°C (90°F).
2. Press OFF switch.
3. Turn ignition switch OFF.
4. Turn ignition switch ON.
5. Press AUTO switch.
6. Check that set temperature is maintained.

Is the inspection result normal?

- YES >> GO TO 2.
NO >> GO TO 9.

2.CHECK FRONT BLOWER MOTOR

1. Start engine.
2. Operate fan switch.
3. Check that fan speed changes. Check operation for all fan speeds.

Is the inspection result normal?

- YES >> GO TO 3.
NO >> GO TO 9.

3.CHECK DISCHARGE AIR (MODE SWITCH AND DEF SWITCH)

1. Operate fan switch to set the fan speed to maximum speed.
2. Operate MODE switch and DEF switch.
3. Check that air outlets change according to each indicated air outlet by placing a hand in front of the outlets. Refer to [HAC-12, "System Description"](#).

Is the inspection result normal?

- YES >> GO TO 4.
NO >> GO TO 9.

4.CHECK INTAKE AIR

1. Press REC switch to set the air inlet to recirculation. The REC switch indicator turns ON.
2. Listen to intake sound and confirm air inlets change.
3. Press FRE switch to set the air inlet to fresh air intake. The REC switch indicator turns OFF.
4. Listen to intake sound and confirm air inlets change.

Is the inspection result normal?

- YES >> GO TO 5.
NO >> GO TO 9.

5.CHECK DISCHARGE AIR TEMPERATURE (LH/RH INDEPENDENT TEMPERATURE ADJUSTMENT FUNCTION)

1. Operate temperature control (driver side).
2. Check that discharge air temperature (driver side) changes.
3. Operate temperature control (passenger side). The DUAL switch indicator is turns ON.
4. Check that the discharge air temperature (passenger side) changes.
5. Press DUAL switch. The DUAL switch indicator turns OFF.
6. Check that air temperature setting (LH/RH) is unified to the driver side temperature setting.

Is the inspection result normal?

- YES >> GO TO 6.

A
B
C
D
E
F
G
H
J
K
L
M
N
O
P

HAC

OPERATION INSPECTION

< BASIC INSPECTION >

[AUTOMATIC AIR CONDITIONING]

NO >> GO TO 9.

6. CHECK WITH TEMPERATURE SETTING LOWERED

1. Operate compressor.
2. Operate temperature control (driver side) and lower the set temperature to 18°C (60°F).
3. Check that cool air blows from the air outlets.

Is the inspection result normal?

YES >> GO TO 7.

NO >> GO TO 9.

7. CHECK TEMPERATURE INCREASE

1. Operate temperature control (driver side) and raise the set temperature to 32°C (90°F).
2. Check that warm air blows from the air outlets.

Is the inspection result normal?

YES >> GO TO 8.

NO >> GO TO 9.

8. CHECK AUTO MODE

1. Press AUTO switch to confirm that "AUTO" is indicated on the display.
2. Operate temperature control (driver side) to check that fan speed or air outlet changes (the air outlet or fan speed varies depending on the ambient temperature, in-vehicle temperature, set temperature, etc.).

Is the inspection result normal?

YES >> Inspection End.

NO >> GO TO 9.

9. CHECK SELF-DIAGNOSIS WITH CONSULT

1. Perform self-diagnosis with CONSULT.
2. Check that any DTC is detected.

Is any DTC detected?

YES >> Refer to [HAC-26, "DTC Index"](#) and perform the appropriate diagnosis.

NO >> GO TO 10.

10. CHECK FAIL-SAFE ACTIVATION

Check that symptom is applied to the fail-safe activation. Refer to [HAC-26, "Fail-safe"](#).

>> Refer to [HAC-84, "Diagnosis Chart By Symptom"](#) and perform the appropriate diagnosis.

ADDITIONAL SERVICE WHEN REPLACING CONTROL UNIT (A/C AUTO AMP.)
< BASIC INSPECTION > [AUTOMATIC AIR CONDITIONING]

ADDITIONAL SERVICE WHEN REPLACING CONTROL UNIT (A/C AUTO AMP.)

Description

INFOID:000000012876757

When replacing A/C auto amp., save or print current vehicle specification with CONSULT “Configuration” before replacement.

BEFORE REPLACEMENT

NOTE:

If “READ CONFIGURATION” can not be used, use the “MANUAL CONFIGURATION” after replacing A/C auto amp.

AFTER REPLACEMENT

CAUTION:

- When replacing A/C auto amp., you must perform “WRITE CONFIGURATION” with CONSULT.
- Never perform “WRITE CONFIGURATION” except for new A/C auto amp.

Work Procedure

INFOID:000000012876758

1. SAVING VEHICLE SPECIFICATION

CONSULT Configuration

Perform “READ CONFIGURATION” to save or print current vehicle specification. Refer to [HAC-42. "Description"](#).

NOTE:

If “READ CONFIGURATION” can not be used, use “MANUAL CONFIGURATION” after replacing A/C auto amp.

>> GO TO 2.

2. REPLACE A/C AUTO AMP.

Replace A/C auto amp. Refer to [HAC-92. "Removal and Installation"](#).

>> GO TO 3.

3. WRITING VEHICLE SPECIFICATION

CONSULT Configuration

Perform “WRITE CONFIGURATION - Config file” or “MANUAL CONFIGURATION” to write vehicle specification. Refer to [HAC-42. "Work Procedure"](#).

>> WORK END

CONFIGURATION (HVAC)

Description

INFOID:000000012876759

Vehicle specification needs to be written with CONSULT because it is not written after replacing A/C auto amp. Configuration has three functions as follows

| Function | Description |
|--------------------------------------|---|
| READ CONFIGURATION | <ul style="list-style-type: none"> • Reads the vehicle configuration of current A/C auto amp. • Saves the read vehicle configuration. |
| WRITE CONFIGURATION - Manual setting | Writes the vehicle configuration with manual setting. |
| WRITE CONFIGURATION - Config file | Writes the vehicle configuration with saved data. |

CAUTION:

- When replacing A/C auto amp., you must perform “WRITE CONFIGURATION” with CONSULT.
- Never perform “WRITE CONFIGURATION” except for new A/C auto amp.

Work Procedure

INFOID:000000012876760

1. WRITING MODE SELECTION

 CONSULT Configuration

Select “CONFIGURATION” of A/C auto amp.

When writing saved data>>GO TO 2.

When writing manually>>GO TO 3.

2. PERFORM “WRITE CONFIGURATION - CONFIG FILE”

 CONSULT Configuration

Perform “WRITE CONFIGURATION - Config file”.

>> WORK END

3. PERFORM “MANUAL CONFIGURATION”

 CONSULT Configuration

Select “MANUAL CONFIGURATION” to write vehicle specifications into the A/C auto amp.

CAUTION:

- Thoroughly read and understand the vehicle specification. Incorrect settings may result in abnormal control of ECU.
- Make sure to select “NEXT” even if the default settings displayed on the CONSULT are the desired settings. If “NEXT” is not selected, the configuration process will be incomplete.

NOTE:

If manual configuration items are not displayed, touch “NEXT”.

>> GO TO 4.

4. OPERATION CHECK

Confirm that each function controlled by A/C auto amp. operates normally.

>> WORK END

SYSTEM SETTING

< BASIC INSPECTION >

[AUTOMATIC AIR CONDITIONING]

SYSTEM SETTING

Temperature Setting Trimmer (Front)

INFOID:000000012876761

DESCRIPTION

If the temperature felt by the customer is different from the front air flow temperature controlled by the temperature setting, the A/C auto amp. control temperature can be adjusted to compensate for the temperature setting.

HOW TO SET

☑ With CONSULT

Perform "TEMP SET CORRECT" in "Work support" of "HVAC".

| Work support items | Display (°C) | Display (°F) |
|--------------------|--------------------|--------------------|
| TEMP SET CORRECT | 3.0 | 6 |
| | 2.5 | 5 |
| | 2.0 | 4 |
| | 1.5 | 3 |
| | 1.0 | 2 |
| | 0.5 | 1 |
| | 0 (initial status) | 0 (initial status) |
| | -0.5 | -1 |
| | -1.0 | -2 |
| | -1.5 | -3 |
| | -2.0 | -4 |
| | -2.5 | -5 |
| | -3.0 | -6 |

NOTE:

- When -3.0°C (-6°F) is corrected on the temperature setting set as 25.0°C (77°F) the temperature controlled by A/C auto amp. is 25.0°C (77°F) -3.0°C (-6°F) = 22.0°C (72°F) and the temperature becomes lower than the temperature setting.
- When the battery cable is disconnected from the negative terminal or when the battery voltage becomes 10 V or less, the setting of the difference between the set temperature and control temperature may be cancelled.

Foot Position Setting Trimmer

INFOID:000000012876762

DESCRIPTION

In FOOT mode, the air blowing to DEF can change ON/OFF.

HOW TO SET

☑ With CONSULT

Perform the "BLOW SET" in "Work support" of "HVAC".

| Work support items | Display | Defroster door position | |
|--------------------|------------------------|-------------------------|----------------|
| | | Auto control | Manual control |
| BLOW SET | Mode1 | OPEN | CLOSE |
| | Mode2 (initial status) | OPEN | OPEN |
| | Mode3 | CLOSE | OPEN |
| | Mode4 | CLOSE | CLOSE |

NOTE:

When the battery cable is disconnected from the negative terminal or when the battery voltage becomes 10V or less, the setting of the discharge air mix ratio in FOOT mode may be cancelled.

SYSTEM SETTING

< BASIC INSPECTION >

[AUTOMATIC AIR CONDITIONING]

Inlet Port Memory Function (FRE)

INFOID:000000012876763

DESCRIPTION

- If the ignition switch is turned to the OFF position while the intake switch is set to OFF (fresh air intake), “Perform the memory” or “Do not perform the memory” of intake switch OFF (fresh air intake) condition can be selected.
- If “Perform the memory” was set, the intake switch will be OFF (fresh air intake) when turning the ignition switch to the ON position again.
- If “Do not perform the memory” was set, the air inlets will be controlled automatically when turning the ignition switch to the ON position again.

HOW TO SET

Ⓟ With CONSULT

Perform the “FRE MEMORY SET” in “Work support” of “HVAC”.

| Work support items | Display | Setting |
|--------------------|-----------------------|--|
| FRE MEMORY SET | WITHOUT | Perform the memory of manual FRE |
| | WITH (initial status) | Do not perform the memory of manual FRE (auto control) |

NOTE:

When the battery cable is disconnected from the negative terminal or when the battery voltage becomes 10 V or less, the setting of the FRE memory function may be cancelled.

Inlet Port Memory Function (REC)

INFOID:000000012876764

DESCRIPTION

- If the ignition switch is turned to the OFF position while the intake switch is set to ON (recirculation), “Perform the memory” or “Do not perform the memory” of intake switch ON (recirculation) condition can be selected.
- If “Perform the memory” was set, the intake switch will be ON (recirculation) when turning the ignition switch to the ON position again.
- If “Do not perform the memory” was set, the air inlets will be controlled automatically when turning the ignition switch to the ON position again.

HOW TO SET

Ⓟ With CONSULT

Perform the “REC MEMORY SET” in “Work support” of “HVAC”.

| Work support items | Display | Setting |
|--------------------|--------------------------|--|
| REC MEMORY SET | WITHOUT (initial status) | Perform the memory of manual REC |
| | WITH | Do not perform the memory of manual REC (auto control) |

NOTE:

When the battery cable is disconnected from the negative terminal or when the battery voltage becomes 10 V or less, the setting of the REC memory function may be cancelled.

U1000 CAN COMM CIRCUIT

< DTC/CIRCUIT DIAGNOSIS >

[AUTOMATIC AIR CONDITIONING]

DTC/CIRCUIT DIAGNOSIS

U1000 CAN COMM CIRCUIT

DTC Description

INFOID:0000000012876765

CAN (Controller Area Network) is a serial communication system for real time application. It is an on-vehicle multiplex communication system with high data communication speed and excellent error detection ability. Many electronic control units are equipped in vehicles, and each control unit shares information and links with other control units during operation (not independent). In CAN communication, control units are connected with two communication lines (CAN-H line, CAN-L line) allowing a high rate of information transmission with less wiring. Each control unit transmits/receives data, but selectively reads required data only. Refer to [LAN-37, "CAN COMMUNICATION SYSTEM : CAN Communication Signal Chart"](#).

DTC DETECTION LOGIC

| DTC No. | CONSULT screen terms (Trouble diagnosis content) | DTC detection condition | |
|---------|---|-------------------------|-----------------------------|
| U1000 | CAN COMM CIRCUIT (CAN COMM CIRCUIT) | Diagnosis condition | When ignition switch is ON. |
| | | Signal (terminal) | - |
| | | Threshold | - |
| | | Diagnosis delay time | 2 seconds or more |

POSSIBLE CAUSE

CAN communication system

FAIL-SAFE

—

DTC CONFIRMATION PROCEDURE

1.PERFORM SELF-DIAGNOSIS

CONSULT

1. Turn ignition switch ON and wait for 2 seconds or more.
2. Select "Self Diagnostic Result" mode of "HVAC".
3. Check DTC.

Is DTC detected?

- YES >> Refer to [HAC-45, "Diagnosis Procedure"](#).
NO >> Refer to [GI-42, "Intermittent Incident"](#).

Diagnosis Procedure

INFOID:0000000012876766

1.CHECK CAN COMMUNICATION SYSTEM

Check CAN communication system. Refer to [LAN-21, "Trouble Diagnosis Flow Chart"](#).

>> Inspection End.

U1010 CONTROL UNIT (CAN)

< DTC/CIRCUIT DIAGNOSIS >

[AUTOMATIC AIR CONDITIONING]

U1010 CONTROL UNIT (CAN)

DTC Description

INFOID:00000001287677

Initial diagnosis of A/C auto amp.

DTC DETECTION LOGIC

| DTC No. | CONSULT screen terms (Trouble diagnosis content) | DTC detection condition | |
|---------|---|-------------------------|-----------------------------|
| | | Diagnosis condition | When ignition switch is ON. |
| U1010 | CONTROL UNIT (CAN) [CONTROL UNIT (CAN)] | Signal (terminal) | - |
| | | Threshold | - |
| | | Diagnosis delay time | - |
| | | | |

POSSIBLE CAUSE

A/C auto amp.

FAIL-SAFE

—

DTC CONFIRMATION PROCEDURE

1.PERFORM SELF-DIAGNOSIS

ⓐCONSULT

1. Turn ignition switch ON.
2. Select "Self Diagnostic Result" mode of "HVAC".
3. Check DTC.

Is DTC detected?

- YES >> Refer to [HAC-46. "Diagnosis Procedure"](#).
NO >> Inspection End.

Diagnosis Procedure

INFOID:00000001287678

1.REPLACE A/C AUTO AMP.

Replace A/C auto amp. Refer to [HAC-92. "Removal and Installation"](#).

>> Inspection End.

B2578, B2579 IN-VEHICLE SENSOR

< DTC/CIRCUIT DIAGNOSIS >

[AUTOMATIC AIR CONDITIONING]

B2578, B2579 IN-VEHICLE SENSOR

DTC Description

INFOID:000000012876769

DTC DETECTION LOGIC

NOTE:

- If DTC is displayed along with DTC U1000, first perform the trouble diagnosis for DTC U1000. Refer to [HAC-45, "DTC Description"](#).
- If DTC is displayed along with DTC U1010, first perform the trouble diagnosis for DTC U1010. Refer to [HAC-46, "DTC Description"](#).

| DTC No. | CONSULT screen terms (Trouble diagnosis content) | DTC detection condition | |
|---------|---|-------------------------|-----------------------------|
| B2578 | IN-VEHICLE SENSOR (SHORT) (In-vehicle sensor) | Diagnosis condition | When ignition switch is ON. |
| | | Signal (terminal) | - |
| | | Threshold | More than 212°F (100°C) |
| | | Diagnosis delay time | - |
| B2579 | IN-VEHICLE SENSOR (OPEN) (In-vehicle sensor) | Diagnosis condition | When ignition switch is ON. |
| | | Signal (terminal) | - |
| | | Threshold | Less than -44°F (-42°C) |
| | | Diagnosis delay time | - |

POSSIBLE CAUSE

- In-vehicle sensor
- A/C auto amp.
- Harness or connectors (The sensor circuit is open or shorted.)

FAIL-SAFE

DTC CONFIRMATION PROCEDURE

1.PERFORM DTC CONFIRMATION PROCEDURE

CONSULT

1. Turn ignition switch ON.
2. Select "Self Diagnostic Result" mode of "HVAC".
3. Check DTC.

Is DTC detected?

YES >> Refer to [HAC-47, "Diagnosis Procedure"](#).

NO >> Inspection End.

Diagnosis Procedure

INFOID:000000012876770

Regarding Wiring Diagram information, refer to [HAC-29, "Wiring Diagram"](#).

1.CHECK IN-VEHICLE SENSOR POWER SUPPLY

1. Turn ignition switch OFF.
2. Disconnect in-vehicle sensor connector.
3. Turn ignition switch ON.
4. Check voltage between in-vehicle sensor harness connector and ground.

B2578, B2579 IN-VEHICLE SENSOR

< DTC/CIRCUIT DIAGNOSIS >

[AUTOMATIC AIR CONDITIONING]

| + | | - | Voltage (Approx.) |
|-------------------|----------|--------|----------------------|
| In-vehicle sensor | | | |
| Connector | Terminal | | |
| M102 | 1 | Ground | 5 V |

Is the inspection result normal?

- YES >> GO TO 2.
NO >> GO TO 4.

2. CHECK IN-VEHICLE SENSOR GROUND CIRCUIT

1. Turn ignition switch OFF.
2. Check continuity between front in-vehicle sensor harness connector and ground.

| In-vehicle sensor | | — | Continuity |
|-------------------|----------|--------|------------|
| Connector | Terminal | | |
| M102 | 2 | Ground | Yes |

Is the inspection result normal?

- YES >> GO TO 3.
NO >> Repair harness or connector.

3. CHECK IN-VEHICLE SENSOR

Check in-vehicle sensor. Refer to [HAC-49. "Component Inspection"](#).

Is the inspection result normal?

- YES >> Replace A/C auto amp. Refer to [HAC-92. "Removal and Installation"](#).
NO >> Replace in-vehicle sensor. Refer to [HAC-94. "Removal and Installation"](#).

4. CHECK IN-VEHICLE SENSOR POWER SUPPLY CIRCUIT FOR OPEN

1. Turn ignition switch OFF.
2. Disconnect A/C auto amp. connector.
3. Check continuity between in-vehicle sensor harness connector and A/C auto amp. harness connector.

| In-vehicle sensor | | A/C auto amp. | | Continuity |
|-------------------|----------|---------------|----------|------------|
| Connector | Terminal | Connector | Terminal | |
| M102 | 1 | M50 | 27 | Yes |

Is the inspection result normal?

- YES >> GO TO 5.
NO >> Repair harness or connector.

5. CHECK IN-VEHICLE SENSOR POWER SUPPLY CIRCUIT FOR GROUND SHORT

Check continuity between in-vehicle sensor harness connector and ground.

| In-vehicle sensor | | — | Continuity |
|-------------------|----------|--------|------------|
| Connector | Terminal | | |
| M102 | 1 | Ground | No |

Is the inspection result normal?

- YES >> GO TO 6.
NO >> Repair harness or connector.

6. CHECK IN-VEHICLE SENSOR POWER SUPPLY CIRCUIT FOR POWER SHORT

1. Turn ignition switch ON.
2. Check voltage between in-vehicle sensor harness connector and ground.

B2578, B2579 IN-VEHICLE SENSOR

< DTC/CIRCUIT DIAGNOSIS >

[AUTOMATIC AIR CONDITIONING]

| + | | - | Voltage (Approx.) |
|-------------------|----------|--------|----------------------|
| In-vehicle sensor | | | |
| Connector | Terminal | | |
| M102 | 1 | Ground | 0 V |

Is the inspection result normal?

- YES >> Replace A/C auto amp. Refer to [HAC-92, "Removal and Installation"](#).
 NO >> Repair harness or connector.

Component Inspection

INFOID:000000012876771

1. CHECK IN-VEHICLE SENSOR

1. Turn ignition switch OFF.
2. Disconnect in-vehicle sensor connector.
3. Check resistance between in-vehicle sensor terminals.

| Terminal | | Condition | Resistance: kΩ |
|----------|---|----------------------|----------------|
| | | Temperature: °C (°F) | |
| 1 | 2 | -15 (5) | 12.73 |
| | | -10 (14) | 9.92 |
| | | -5 (23) | 7.80 |
| | | 0 (32) | 6.19 |
| | | 5 (41) | 4.95 |
| | | 10 (50) | 3.99 |
| | | 15 (59) | 3.24 |
| | | 20 (68) | 2.65 |
| | | 25 (77) | 2.19 |
| | | 30 (86) | 1.81 |
| | | 35 (95) | 1.51 |
| | | 40 (104) | 1.27 |
| | | 45 (113) | 1.07 |

Is the inspection result normal?

- YES >> Inspection End.
 NO >> Replace in-vehicle sensor. Refer to [HAC-94, "Removal and Installation"](#).

B257B, B257C AMBIENT SENSOR

< DTC/CIRCUIT DIAGNOSIS >

[AUTOMATIC AIR CONDITIONING]

B257B, B257C AMBIENT SENSOR

DTC Description

INFOID:000000012876772

DTC DETECTION LOGIC

NOTE:

- If DTC is displayed along with DTC U1000, first perform the trouble diagnosis for DTC U1000. Refer to [HAC-45, "DTC Description"](#).
- If DTC is displayed along with DTC U1010, first perform the trouble diagnosis for DTC U1010. Refer to [HAC-46, "DTC Description"](#).

| DTC No. | CONSULT screen terms (Trouble diagnosis content) | DTC detection condition | |
|---------|---|-------------------------|-----------------------------|
| | | Diagnosis condition | When ignition switch is ON. |
| B257B | AMBIENT SENSOR (SHORT) (Ambient sensor) | Signal (terminal) | - |
| | | Threshold | More than 212°F (100°C) |
| | | Diagnosis delay time | - |
| | | Diagnosis condition | When ignition switch is ON. |
| B257C | AMBIENT SENSOR (OPEN) (Ambient sensor) | Signal (terminal) | - |
| | | Threshold | Less than -44°F (-42°C) |
| | | Diagnosis delay time | - |
| | | Diagnosis condition | When ignition switch is ON. |

POSSIBLE CAUSE

- Ambient sensor
- A/C auto amp.
- Harness or connectors (The sensor circuit is open or shorted.)

FAIL-SAFE

—

DTC CONFIRMATION PROCEDURE

1. PERFORM DTC CONFIRMATION PROCEDURE

CONSULT

1. Turn ignition switch ON.
2. Select "Self Diagnostic Result" mode of "HVAC".
3. Check DTC.

Is DTC detected?

- YES >> Refer to [HAC-50, "Diagnosis Procedure"](#).
- NO >> Inspection End.

Diagnosis Procedure

INFOID:000000012876773

Regarding Wiring Diagram information, refer to [HAC-29, "Wiring Diagram"](#).

1. CHECK AMBIENT SENSOR POWER SUPPLY

1. Turn ignition switch OFF.
2. Disconnect ambient sensor connector.
3. Turn ignition switch ON.
4. Check voltage between ambient sensor harness connector and ground.

B257B, B257C AMBIENT SENSOR

< DTC/CIRCUIT DIAGNOSIS >

[AUTOMATIC AIR CONDITIONING]

| + | | - | Voltage (Approx.) |
|----------------|----------|--------|----------------------|
| Ambient sensor | | | |
| Connector | Terminal | | |
| E206 | 2 | Ground | 5 V |

Is the inspection result normal?

- YES >> GO TO 2.
- NO >> GO TO 4.

2. CHECK AMBIENT SENSOR GROUND CIRCUIT

1. Turn ignition switch OFF.
2. Check continuity between ambient sensor harness connector and ground.

| Ambient sensor | | — | Continuity |
|----------------|----------|--------|------------|
| Connector | Terminal | | |
| E206 | 1 | Ground | Yes |

Is the inspection result normal?

- YES >> GO TO 3.
- NO >> Repair harness or connector.

3. CHECK AMBIENT SENSOR

Check ambient sensor. Refer to [HAC-52. "Component Inspection"](#).

Is the inspection result normal?

- YES >> Replace A/C auto amp. Refer to [HAC-92. "Removal and Installation"](#).
- NO >> Replace ambient sensor. Refer to [HAC-93. "Removal and Installation"](#).

4. CHECK AMBIENT SENSOR POWER SUPPLY CIRCUIT FOR OPEN

1. Turn ignition switch OFF.
2. Disconnect A/C auto amp. connector.
3. Check continuity between ambient sensor harness connector and A/C auto amp. harness connector.

| Ambient sensor | | A/C auto amp. | | Continuity |
|----------------|----------|---------------|----------|------------|
| Connector | Terminal | Connector | Terminal | |
| E206 | 2 | M50 | 7 | Yes |

Is the inspection result normal?

- YES >> GO TO 5.
- NO >> Repair harness or connector.

5. CHECK AMBIENT SENSOR POWER SUPPLY CIRCUIT FOR GROUND SHORT

Check continuity between ambient sensor harness connector and ground.

| Ambient sensor | | — | Continuity |
|----------------|----------|--------|------------|
| Connector | Terminal | | |
| E206 | 2 | Ground | No |

Is the inspection result normal?

- YES >> GO TO 6.
- NO >> Repair harness or connector.

6. CHECK AMBIENT SENSOR POWER SUPPLY CIRCUIT FOR POWER SHORT

1. Turn ignition switch ON.
2. Check voltage between ambient sensor harness connector and ground.

A
B
C
D
E
F
G
H
J
K
L
M
N
O
P

HAC

B257B, B257C AMBIENT SENSOR

< DTC/CIRCUIT DIAGNOSIS >

[AUTOMATIC AIR CONDITIONING]

| + | | - | Voltage (Approx.) |
|----------------|----------|--------|----------------------|
| Ambient sensor | | | |
| Connector | Terminal | | |
| E206 | 2 | Ground | 0 V |

Is the inspection result normal?

- YES >> Replace A/C auto amp. Refer to [HAC-92, "Removal and Installation"](#).
NO >> Repair harness or connector.

Component Inspection

INFOID:000000012876774

1. CHECK AMBIENT SENSOR

1. Turn ignition switch OFF.
2. Disconnect ambient sensor connector.
3. Check resistance between ambient sensor terminals.

| Terminal | | Condition | Resistance: kΩ |
|----------|------|----------------------|----------------|
| | | Temperature: °C (°F) | |
| 1 | 2 | -15 (5) | 12.73 |
| | | -10 (14) | 9.92 |
| | | -5 (23) | 7.80 |
| | | 0 (32) | 6.19 |
| | | 5 (41) | 4.95 |
| | | 10 (50) | 3.99 |
| | | 15 (59) | 3.24 |
| | | 20 (68) | 2.65 |
| | | 25 (77) | 2.19 |
| | | 30 (86) | 1.81 |
| | | 35 (95) | 1.51 |
| | | 40 (104) | 1.27 |
| 45 (113) | 1.07 | | |

Is the inspection result normal?

- YES >> Inspection End.
NO >> Replace ambient sensor. Refer to [HAC-93, "Removal and Installation"](#).

B2581, B2582 INTAKE SENSOR

< DTC/CIRCUIT DIAGNOSIS >

[AUTOMATIC AIR CONDITIONING]

B2581, B2582 INTAKE SENSOR

DTC Description

INFOID:000000012876775

DTC DETECTION LOGIC

NOTE:

- If DTC is displayed along with DTC U1000, first perform the trouble diagnosis for DTC U1000. Refer to [HAC-45, "DTC Description"](#).
- If DTC is displayed along with DTC U1010, first perform the trouble diagnosis for DTC U1010. Refer to [HAC-46, "DTC Description"](#).

| DTC No. | CONSULT screen terms (Trouble diagnosis content) | DTC detection condition | |
|---------|---|-------------------------|-----------------------------|
| | | Diagnosis condition | When ignition switch is ON. |
| B2581 | INTAKE SENSOR (SHORT) (Intake sensor) | Signal (terminal) | - |
| | | Threshold | More than 212°F (100°C) |
| | | Diagnosis delay time | - |
| | | Diagnosis condition | When ignition switch is ON. |
| B2582 | INTAKE SENSOR (OPEN) (Intake sensor) | Signal (terminal) | - |
| | | Threshold | Less than -44°F (-42°C) |
| | | Diagnosis delay time | - |
| | | Diagnosis condition | When ignition switch is ON. |

POSSIBLE CAUSE

- Intake sensor
- A/C auto amp.
- Harness or connectors (The sensor circuit is open or shorted.)

FAIL-SAFE

—

DTC CONFIRMATION PROCEDURE

1. PERFORM DTC CONFIRMATION PROCEDURE

CONSULT

1. Turn ignition switch ON.
2. Select "Self Diagnostic Result" mode of "HVAC".
3. Check DTC.

Is DTC detected?

YES >> Refer to [HAC-53, "Diagnosis Procedure"](#).

NO >> Inspection End.

Diagnosis Procedure

INFOID:000000012876776

Regarding Wiring Diagram information, refer to [HAC-29, "Wiring Diagram"](#).

1. CHECK INTAKE SENSOR POWER SUPPLY

1. Turn ignition switch OFF.
2. Disconnect intake sensor connector.
3. Turn ignition switch ON.
4. Check voltage between intake sensor harness connector and ground.

B2581, B2582 INTAKE SENSOR

< DTC/CIRCUIT DIAGNOSIS >

[AUTOMATIC AIR CONDITIONING]

| + | | - | Voltage (Approx.) |
|---------------|----------|--------|----------------------|
| Intake sensor | | | |
| Connector | Terminal | | |
| M103 | 1 | Ground | 5 V |

Is the inspection result normal?

- YES >> GO TO 2.
- NO >> GO TO 4.

2. CHECK INTAKE SENSOR GROUND CIRCUIT

1. Turn ignition switch OFF.
2. Check continuity between intake sensor harness connector and ground.

| Intake sensor | | — | Continuity |
|---------------|----------|--------|------------|
| Connector | Terminal | | |
| M103 | 2 | Ground | Yes |

Is the inspection result normal?

- YES >> GO TO 3.
- NO >> Repair harness or connector.

3. CHECK INTAKE SENSOR

Check intake sensor. Refer to [HAC-55. "Component Inspection"](#).

Is the inspection result normal?

- YES >> Replace A/C auto amp. Refer to [HAC-92. "Removal and Installation"](#).
- NO >> Replace intake sensor. Refer to [HAC-96. "Removal and Installation"](#).

4. CHECK INTAKE SENSOR POWER SUPPLY CIRCUIT FOR OPEN

1. Turn ignition switch OFF.
2. Disconnect A/C auto amp. connector.
3. Check continuity between intake sensor harness connector and A/C auto amp. harness connector.

| Intake sensor | | A/C auto amp. | | Continuity |
|---------------|----------|---------------|----------|------------|
| Connector | Terminal | Connector | Terminal | |
| M103 | 1 | M50 | 28 | Yes |

Is the inspection result normal?

- YES >> GO TO 5.
- NO >> Repair harness or connector.

5. CHECK INTAKE SENSOR POWER SUPPLY CIRCUIT FOR GROUND SHORT

Check continuity between intake sensor harness connector and ground.

| Intake sensor | | — | Continuity |
|---------------|----------|--------|------------|
| Connector | Terminal | | |
| M103 | 1 | Ground | No |

Is the inspection result normal?

- YES >> GO TO 6.
- NO >> Repair harness or connector.

6. CHECK INTAKE SENSOR POWER SUPPLY CIRCUIT FOR POWER SHORT

1. Turn ignition switch ON.
2. Check voltage between intake sensor harness connector and ground.

B2581, B2582 INTAKE SENSOR

< DTC/CIRCUIT DIAGNOSIS >

[AUTOMATIC AIR CONDITIONING]

| + | | - | Voltage (Approx.) |
|---------------|----------|--------|----------------------|
| Intake sensor | | | |
| Connector | Terminal | | |
| M103 | 1 | Ground | 0 V |

Is the inspection result normal?

- YES >> Replace A/C auto amp. Refer to [HAC-92, "Removal and Installation"](#).
NO >> Repair harness or connector.

Component Inspection

INFOID:000000012876777

1. CHECK INTAKE SENSOR

1. Turn ignition switch OFF.
2. Disconnect intake sensor connector.
3. Check resistance between intake sensor terminals.

| Terminal | | Condition | Resistance: kΩ |
|----------|------|----------------------|----------------|
| | | Temperature: °C (°F) | |
| 1 | 2 | -15 (5) | 17.73 |
| | | -10 (14) | 13.46 |
| | | -5 (23) | 10.33 |
| | | 0 (32) | 8.00 |
| | | 5 (41) | 6.25 |
| | | 10 (50) | 4.93 |
| | | 15 (59) | 3.92 |
| | | 20 (68) | 3.14 |
| | | 25 (77) | 2.54 |
| | | 30 (86) | 2.06 |
| | | 35 (95) | 1.69 |
| | | 40 (104) | 1.39 |
| 45 (113) | 1.15 | | |

Is the inspection result normal?

- YES >> Inspection End.
NO >> Replace intake sensor. Refer to [HAC-96, "Removal and Installation"](#).

B2630, B2631 SUNLOAD SENSOR

< DTC/CIRCUIT DIAGNOSIS >

[AUTOMATIC AIR CONDITIONING]

B2630, B2631 SUNLOAD SENSOR

DTC Description

INFOID:000000012876778

DTC DETECTION LOGIC

| DTC No. | CONSULT screen terms (Trouble diagnosis content) | DTC detection condition | |
|---------|---|-------------------------|--|
| B2630 | SUNLOAD SEN (SHORT) (Sunload sensor) | Diagnosis condition | When ignition switch is ON. |
| | | Signal (terminal) | - |
| | | Threshold | Detected calorie at sunload sensor 1395 w/ m ² (1200 kcal/m ² ·h) or more |
| | | Diagnosis delay time | - |
| B2631 | SUNLOAD SEN (OPEN) (Sunload sensor) | Diagnosis condition | When ignition switch is ON. |
| | | Signal (terminal) | - |
| | | Threshold | Detected calorie at sunload sensor 0 w/m ² (0 kcal/m ² ·h) |
| | | Diagnosis delay time | - |

POSSIBLE CAUSE

- Sunload sensor
- A/C auto amp.
- Harness and connector (The sensor circuit is open or shorted.)

FAIL-SAFE

—

DTC CONFIRMATION PROCEDURE

1. PERFORM DTC CONFIRMATION PROCEDURE

CONSULT

1. Turn ignition switch ON.
2. Select "Self Diagnostic Result" mode of "HVAC".
3. Check DTC.

NOTE:

- If DTC is displayed along with DTC U1000 or U1010, first diagnose the DTC U1000 or U1010. Refer to [HAC-45, "DTC Description"](#) or [HAC-46, "DTC Description"](#).
- Sunload sensor may register a malfunction when indoors, at dusk, or at other times when light is insufficient. When performing the diagnosis indoors, light the sunload sensor with a lamp (60W or more).

Is DTC No. "B2630" or "B2631" displayed?

- YES >> Perform trouble diagnosis for the sunload sensor. Refer to [HAC-56, "Diagnosis Procedure"](#).
NO >> Inspection End.

Diagnosis Procedure

INFOID:000000012876779

Regarding Wiring Diagram information, refer to [HAC-29, "Wiring Diagram"](#).

1. CHECK SUNLOAD SENSOR POWER SUPPLY

1. Disconnect sunload sensor connector.
2. Turn ignition switch ON.
3. Check voltage between sunload sensor harness connector M101 terminal 1 and ground.

B2630, B2631 SUNLOAD SENSOR

< DTC/CIRCUIT DIAGNOSIS >

[AUTOMATIC AIR CONDITIONING]

| + | | - | Voltage (Approx.) |
|----------------|----------|--------|----------------------|
| Sunload sensor | | | |
| Connector | Terminal | | |
| M101 | 1 | Ground | 5 V |

Is the inspection result normal?

- YES >> GO TO 2.
- NO >> GO TO 4.

2.CHECK CONTINUITY BETWEEN SUNLOAD SENSOR AND A/C AUTO AMP.

1. Turn ignition switch OFF.
2. Disconnect A/C auto amp. connector.
3. Check continuity between sunload sensor harness connector M101 terminal 2 and A/C auto amp. harness connector M50 terminal 26.

| Sunload sensor | | A/C auto amp. | | Continuity |
|----------------|----------|---------------|----------|------------|
| Connector | Terminal | Connector | Terminal | |
| M101 | 2 | M50 | 26 | Yes |

Is the inspection result normal?

- YES >> GO TO 3.
- NO >> Repair harness or connector.

3.CHECK SUNLOAD SENSOR

1. Reconnect sunload sensor connector and A/C auto amp. connector.
2. Check sunload sensor. Refer to [HAC-57. "Component Inspection"](#).

Is the inspection result normal?

- YES >> Replace A/C auto amp. Refer to [HAC-92. "Removal and Installation"](#).
- NO >> Replace sunload sensor. Refer to [HAC-95. "Removal and Installation"](#).

4.CHECK CONTINUITY BETWEEN SUNLOAD SENSOR AND A/C AUTO AMP.

1. Turn ignition switch OFF.
2. Disconnect A/C auto amp. connector.
3. Check continuity between sunload sensor harness connector M101 terminal 1 and A/C auto amp. harness connector M50 terminal 9.

| Sunload sensor | | A/C auto amp. | | Continuity |
|----------------|----------|---------------|----------|------------|
| Connector | Terminal | Connector | Terminal | |
| M101 | 1 | M50 | 9 | Yes |

4. Check continuity between sunload sensor harness connector M101 terminal 1 and ground.

| Sunload sensor | | - | Continuity |
|----------------|----------|--------|------------|
| Connector | Terminal | | |
| M101 | 1 | Ground | No |

Is the inspection result normal?

- YES >> Replace A/C auto amp. Refer to [HAC-92. "Removal and Installation"](#).
- NO >> Repair harness or connector.

Component Inspection

INFOID:000000012876780

1.CHECK SUNLOAD SENSOR

1. Turn ignition switch ON.
2. Check voltage between A/C auto amp. harness connector and ground.

B2630, B2631 SUNLOAD SENSOR

< DTC/CIRCUIT DIAGNOSIS >

[AUTOMATIC AIR CONDITIONING]

| (+) | | (-) |
|---------------|----------|--------|
| A/C auto amp. | | — |
| Connector | Terminal | |
| M50 | 9 | Ground |

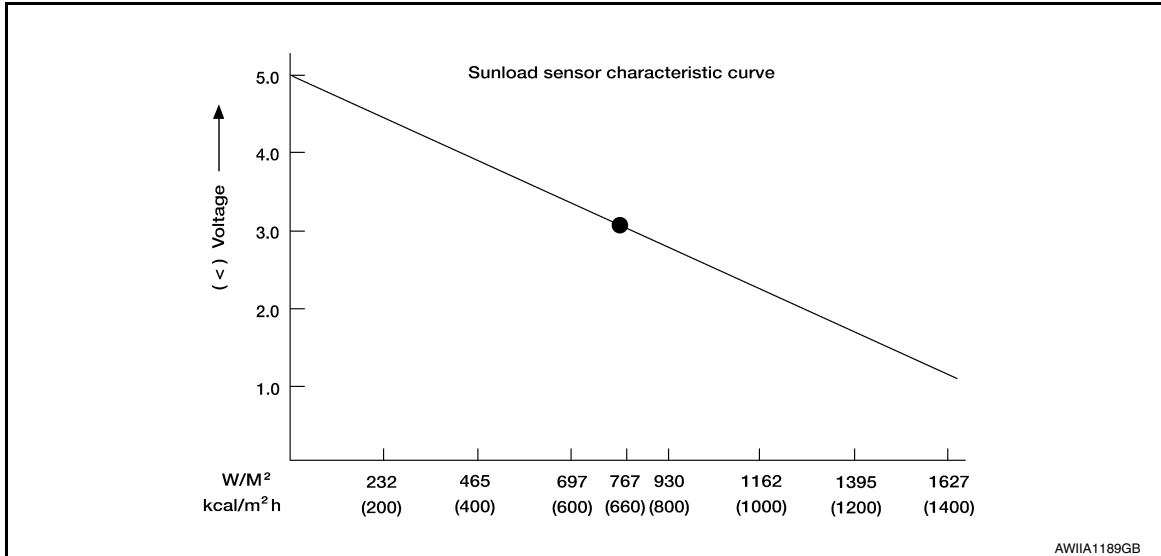

NOTE:

Select a place in direct sunlight when checking sunload sensor.

Is the inspection result normal?

YES >> Inspection End.

NO >> Replace sunload sensor. Refer to [HAC-95, "Removal and Installation"](#).

B2632, B2633 AIR MIX DOOR MOTOR (DRIVER SIDE)

< DTC/CIRCUIT DIAGNOSIS >

[AUTOMATIC AIR CONDITIONING]

B2632, B2633 AIR MIX DOOR MOTOR (DRIVER SIDE)

DTC Description

INFOID:0000000012876781

DTC DETECTION LOGIC

| DTC No. | CONSULT screen terms (Trouble diagnosis content) | DTC detection condition | |
|---------|---|-------------------------|-----------------------------|
| B2632 | DR AIR MIX DOOR MOT (SHORT) (Driver side air mix door motor) | Diagnosis condition | When ignition switch is ON. |
| | | Signal (terminal) | - |
| | | Threshold | PBR position 95% or more |
| | | Diagnosis delay time | - |
| B2633 | DR AIR MIX DOOR MOT (OPEN) (Driver side air mix door motor) | Diagnosis condition | When ignition switch is ON. |
| | | Signal (terminal) | - |
| | | Threshold | PBR position 5% or less |
| | | Diagnosis delay time | - |

POSSIBLE CAUSE

- Air mix door motor LH
- Air mix door motor LH installation condition
- A/C auto amp.
- Harness and connector (Air mix door motor LH circuit is open or shorted)

FAIL-SAFE

—

DTC CONFIRMATION PROCEDURE

1. PERFORM DTC CONFIRMATION PROCEDURE

CONSULT

1. Turn ignition switch ON.
2. Select "Self Diagnostic Result" mode of "HVAC".
3. Check DTC.

Is DTC detected?

- YES >> Refer to [HAC-59. "Diagnosis Procedure"](#).
NO >> Inspection End.

Diagnosis Procedure

INFOID:0000000012876782

Regarding Wiring Diagram information, refer to [HAC-29. "Wiring Diagram"](#).

1. CHECK AIR MIX DOOR MOTOR LH COMMUNICATION SIGNAL

1. Turn ignition switch ON.
2. Check output waveform between air mix door motor LH harness connector and ground with the oscilloscope.

B2632, B2633 AIR MIX DOOR MOTOR (DRIVER SIDE)

< DTC/CIRCUIT DIAGNOSIS >

[AUTOMATIC AIR CONDITIONING]

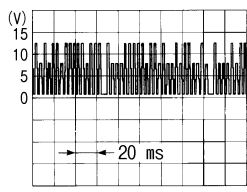
| + | | - | Output waveform |
|-----------------------|----------|--------|---|
| Air mix door motor LH | | | |
| Connector | Terminal | | |
| M155 | 3 | Ground |  <p style="text-align: right; font-size: small;">SJIA1453J</p> |

Is the inspection result normal?

- YES >> GO TO 2.
- NO >> GO TO 3.

2. CHECK INSTALLATION OF AIR MIX DOOR MOTOR LH

Check air mix door motor LH is properly installed. Refer to [HAC-98, "Exploded View"](#).

Is the inspection result normal?

- YES >> Replace air mix door motor LH. Refer to [HAC-99, "AIR MIX DOOR MOTOR : Removal and Installation - \(LH\)"](#).
- NO >> Repair or replace malfunctioning part.

3. CHECK AIR MIX DOOR MOTOR LH COMMUNICATION SIGNAL CIRCUIT

1. Turn ignition switch OFF.
2. Disconnect air mix door motor LH and A/C auto amp. connector.
3. Check continuity between air mix door motor LH harness connector and A/C auto amp. harness connector.

| Air mix door motor LH | | A/C auto amp. | | Continuity |
|-----------------------|----------|---------------|----------|------------|
| Connector | Terminal | Connector | Terminal | |
| M155 | 3 | M50 | 16 | Yes |

Is the inspection result normal?

- YES >> Replace A/C auto amp. Refer to [HAC-92, "Removal and Installation"](#).
- NO >> Repair harness or connector.

B2634, B2635 AIR MIX DOOR MOTOR (PASSENGER SIDE)

< DTC/CIRCUIT DIAGNOSIS >

[AUTOMATIC AIR CONDITIONING]

B2634, B2635 AIR MIX DOOR MOTOR (PASSENGER SIDE)

DTC Description

INFOID:000000012876783

DTC DETECTION LOGIC

| DTC No. | CONSULT screen terms (Trouble diagnosis content) | DTC detection condition | |
|---------|--|-------------------------|-----------------------------|
| B2634 | PASS AIR MIX DOOR MOT (SHORT) (Passenger side air mix door motor) | Diagnosis condition | When ignition switch is ON. |
| | | Signal (terminal) | - |
| | | Threshold | PBR position 95% or more |
| | | Diagnosis delay time | - |
| B2635 | PASS AIR MIX DOOR MOT (OPEN) (Passenger side air mix door motor) | Diagnosis condition | When ignition switch is ON. |
| | | Signal (terminal) | - |
| | | Threshold | PBR position 5% or less |
| | | Diagnosis delay time | - |

POSSIBLE CAUSE

- Air mix door motor RH
- Air mix door motor RH installation condition
- A/C auto amp.
- Harness and connector (Air mix door motor RH circuit is open or shorted)

FAIL-SAFE

—

DTC CONFIRMATION PROCEDURE

1. PERFORM DTC CONFIRMATION PROCEDURE

④ With CONSULT

1. Turn ignition switch ON.
2. Select "Self Diagnostic Result" mode of "HVAC".
3. Check DTC.

Is DTC detected?

- YES >> Refer to [HAC-61, "Diagnosis Procedure"](#).
NO >> Inspection End.

Diagnosis Procedure

INFOID:000000012876784

Regarding Wiring Diagram information, refer to [HAC-29, "Wiring Diagram"](#).

1. CHECK AIR MIX DOOR MOTOR RH COMMUNICATION SIGNAL

1. Turn ignition switch ON.
2. Check output waveform between front air mix door motor RH harness connector and ground with the oscilloscope.

B2634, B2635 AIR MIX DOOR MOTOR (PASSENGER SIDE)

< DTC/CIRCUIT DIAGNOSIS >

[AUTOMATIC AIR CONDITIONING]

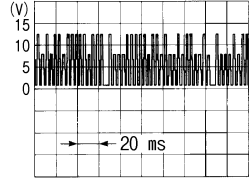
| + | | - | Output waveform |
|-----------------------|----------|--------|--|
| Air mix door motor RH | | | |
| Connector | Terminal | | |
| M156 | 3 | Ground |  <p style="text-align: right; font-size: small;">S/JIA1453J</p> |

Is the inspection result normal?

- YES >> GO TO 2.
- NO >> GO TO 3.

2. CHECK INSTALLATION OF AIR MIX DOOR MOTOR RH

Check air mix door motor RH is properly installed. Refer to [HAC-98, "Exploded View"](#).

Is the inspection result normal?

- YES >> Replace air mix door motor RH. Refer to [HAC-99, "AIR MIX DOOR MOTOR : Removal and Installation - \(RH\)"](#).
- NO >> Repair or replace malfunctioning part.

3. CHECK AIR MIX DOOR MOTOR RH COMMUNICATION SIGNAL CIRCUIT

1. Turn ignition switch OFF.
2. Disconnect air mix door motor RH and A/C auto amp. connector.
3. Check continuity between air mix door motor RH harness connector and A/C auto amp. harness connector.

| Air mix door motor RH | | A/C auto amp. | | Continuity |
|-----------------------|----------|---------------|----------|------------|
| Connector | Terminal | Connector | Terminal | |
| M156 | 3 | M50 | 16 | Yes |

Is the inspection result normal?

- YES >> Replace A/C auto amp. Refer to [HAC-92, "Removal and Installation"](#).
- NO >> Repair harness or connector.

B2636, B2637, B2638, B2639, B2654, B2655 MODE DOOR MOTOR

< DTC/CIRCUIT DIAGNOSIS >

[AUTOMATIC AIR CONDITIONING]

B2636, B2637, B2638, B2639, B2654, B2655 MODE DOOR MOTOR

DTC Description

INFOID:000000012876785

DTC DETECTION LOGIC

| DTC No. | CONSULT screen terms (Trouble diagnosis content) | DTC detection condition | |
|---------|---|-------------------------|-----------------------------|
| B2636 | DR VENT DOOR FAIL (DR VENT DOOR FAIL) | Diagnosis condition | When ignition switch is ON. |
| | | Signal (terminal) | - |
| | | Threshold | - |
| | | Diagnosis delay time | - |
| B2637 | DR B/L DOOR FAIL (DR B/L DOOR FAIL) | Diagnosis condition | When ignition switch is ON. |
| | | Signal (terminal) | - |
| | | Threshold | - |
| | | Diagnosis delay time | - |
| B2638 | DR D/F1 DOOR FAIL (DR D/F1 DOOR FAIL) | Diagnosis condition | When ignition switch is ON. |
| | | Signal (terminal) | - |
| | | Threshold | - |
| | | Diagnosis delay time | - |
| B2639 | DR DEF DOOR FAIL (DR DEF DOOR FAIL) | Diagnosis condition | When ignition switch is ON. |
| | | Signal (terminal) | - |
| | | Threshold | - |
| | | Diagnosis delay time | - |
| B2654 | D/F2 DOOR FAIL (D/F2 DOOR FAIL) | Diagnosis condition | When ignition switch is ON. |
| | | Signal (terminal) | - |
| | | Threshold | - |
| | | Diagnosis delay time | - |
| B2655 | B/L2 DOOR FAIL (B/L2 DOOR FAIL) | Diagnosis condition | When ignition switch is ON. |
| | | Signal (terminal) | - |
| | | Threshold | - |
| | | Diagnosis delay time | - |

POSSIBLE CAUSE

- Mode door motor
- Mode door motor control linkage installation condition
- A/C auto amp.
- Harness and connector (Mode door motor circuit is open or shorted)

FAIL-SAFE

—

DTC CONFIRMATION PROCEDURE

1. PERFORM DTC CONFIRMATION PROCEDURE

ⓂCONSULT

1. Turn ignition switch ON.
2. Select "Self Diagnostic Result" mode of "HVAC".
3. Check DTC.

Is DTC detected?

- YES >> Refer to [HAC-64. "Diagnosis Procedure"](#).
- NO >> Inspection End.

B2636, B2637, B2638, B2639, B2654, B2655 MODE DOOR MOTOR

< DTC/CIRCUIT DIAGNOSIS >

[AUTOMATIC AIR CONDITIONING]

Diagnosis Procedure

INFOID:000000012876786

Regarding Wiring Diagram information, refer to [HAC-29. "Wiring Diagram"](#).

1. CHECK MODE DOOR MOTOR COMMUNICATION SIGNAL

1. Turn ignition switch ON.
2. Check output waveform between mode door motor harness connector and ground with the oscilloscope.

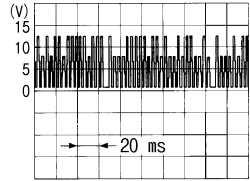
| + | | - | Output waveform |
|-----------------|----------|--------|--|
| Mode door motor | | | |
| Connector | Terminal | | |
| M154 | 3 | Ground |  SJIA1453J |

Is the inspection result normal?

- YES >> GO TO 2.
NO >> GO TO 3.

2. CHECK INSTALLATION OF MODE DOOR MOTOR

Check mode door motor is properly installed. Refer to [HAC-98. "Exploded View"](#).

Is the inspection result normal?

- YES >> Replace mode door motor. Refer to [HAC-99. "MODE DOOR MOTOR : Removal and Installation"](#).
NO >> Repair or replace malfunctioning part.

3. CHECK MODE DOOR MOTOR COMMUNICATION SIGNAL CIRCUIT

1. Turn ignition switch OFF.
2. Disconnect mode door motor and A/C auto amp. connector.
3. Check continuity between mode door motor harness connector and A/C auto amp. harness connector.

| Mode door motor | | A/C auto amp. | | Continuity |
|-----------------|----------|---------------|----------|------------|
| Connector | Terminal | Connector | Terminal | |
| M154 | 3 | M50 | 16 | Yes |

Is the inspection result normal?

- YES >> Replace A/C auto amp. Refer to [HAC-92. "Removal and Installation"](#).
NO >> Repair harness or connector.

B263D, B263E, B263F INTAKE DOOR MOTOR

< DTC/CIRCUIT DIAGNOSIS >

[AUTOMATIC AIR CONDITIONING]

B263D, B263E, B263F INTAKE DOOR MOTOR

DTC Description

INFOID:000000012876787

DTC DETECTION LOGIC

| DTC No. | CONSULT screen terms (Trouble diagnosis content) | DTC detection condition | |
|---------|---|-------------------------|------------------------------|
| B263D | FRE DOOR FAIL (FRE DOOR FAIL) | Diagnosis condition | When Ignition switch is ON. |
| | | Signal (terminal0) | - |
| | | Threshold | Detected at FRE position |
| | | Diagnosis delay time | - |
| B263E | 20P FRE DOOR FAIL (20P FRE DOOR FAIL) | Diagnosis condition | When Ignition switch is ON. |
| | | Signal (terminal0) | - |
| | | Threshold | Detected at 20% FRE position |
| | | Diagnosis delay time | - |
| B263F | REC DOOR FAIL (REC DOOR FAIL) | Diagnosis condition | When Ignition switch is ON. |
| | | Signal (terminal0) | - |
| | | Threshold | Detected at REC position |
| | | Diagnosis delay time | - |

POSSIBLE CAUSE

- Intake door motor
- A/C auto amp.
- Harness and connector (Intake door motor circuit is open or shorted)

FAIL-SAFE

—

DTC CONFIRMATION PROCEDURE

1. PERFORM DTC CONFIRMATION PROCEDURE

CONSULT

1. Turn ignition switch ON.
2. Select "Self Diagnostic Result" mode of "HVAC".
3. Check DTC.

Is DTC detected?

- YES >> Refer to [HAC-65. "Diagnosis Procedure"](#).
NO >> Inspection End.

Diagnosis Procedure

INFOID:000000012876788

Regarding Wiring Diagram information, refer to [HAC-29. "Wiring Diagram"](#).

1. CHECK INTAKE DOOR MOTOR COMMUNICATION SIGNAL

1. Turn ignition switch ON.
2. Check output waveform between intake door motor harness connector and ground with the oscilloscope.

B263D, B263E, B263F INTAKE DOOR MOTOR

< DTC/CIRCUIT DIAGNOSIS >

[AUTOMATIC AIR CONDITIONING]

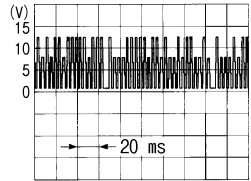
| | | | |
|-------------------|----------|--------|---|
| + | | - | Output waveform |
| Intake door motor | | | |
| Connector | Terminal | | |
| M153 | 3 | Ground |  <p style="text-align: right; font-size: small;">SJIA1453J</p> |

Is the inspection result normal?

- YES >> GO TO 2.
 NO >> GO TO 3.

2. CHECK INSTALLATION OF INTAKE DOOR MOTOR

Check intake door motor is properly installed. Refer to [HAC-98, "Exploded View"](#).

Is the inspection result normal?

- YES >> Replace intake door motor. Refer to [HAC-100, "INTAKE DOOR MOTOR : Removal and Installation"](#).
 NO >> Repair or replace malfunctioning part.

3. CHECK INTAKE DOOR MOTOR COMMUNICATION SIGNAL CIRCUIT

1. Turn ignition switch OFF.
2. Disconnect intake door motor and A/C auto amp. connector.
3. Check continuity between intake door motor harness connector and A/C auto amp. harness connector.

| | | | | |
|-------------------|----------|---------------|----------|------------|
| Intake door motor | | A/C auto amp. | | Continuity |
| Connector | Terminal | Connector | Terminal | |
| M153 | 3 | M50 | 16 | Yes |

Is the inspection result normal?

- YES >> Replace A/C auto amp. Refer to [HAC-92, "Removal and Installation"](#).
 NO >> Repair harness or connector.

B2796 CONTROL COMMUNICATION

< DTC/CIRCUIT DIAGNOSIS >

[AUTOMATIC AIR CONDITIONING]

B2796 CONTROL COMMUNICATION

DTC Description

INFOID:000000012876789

DTC DETECTION LOGIC

| DTC No. | CONSULT screen terms (Trouble diagnosis content) | DTC detection condition | |
|---------|---|-------------------------|-----------------------------|
| B2796 | Communication error (Communication error) | Diagnosis condition | When Ignition switch is ON. |
| | | Signal (terminal) | - |
| | | Threshold | - |
| | | Diagnosis delay time | 2 seconds or more |

POSSIBLE CAUSE

- A/C switch assembly
- A/C auto amp.
- Harness and connector (Communication line is open or shorted)

FAIL-SAFE

—

DTC CONFIRMATION PROCEDURE

1. PERFORM DTC CONFIRMATION PROCEDURE

CONSULT

1. Turn ignition switch ON.
2. Select "Self Diagnostic Result" mode of "HVAC".
3. Check DTC.

Is DTC detected?

- YES >> Refer to [HAC-67. "Diagnosis Procedure"](#).
- NO >> Inspection End.

Diagnosis Procedure

INFOID:000000012876790

Regarding Wiring Diagram information, refer to [HAC-29. "Wiring Diagram"](#).

1. CHECK COMMUNICATION SIGNAL CIRCUIT (A/C AUTO AMP. → A/C SWITCH ASSEMBLY) FOR OPEN

1. Turn ignition switch OFF.
2. Disconnect A/C switch assembly and A/C auto amp. connector.
3. Check continuity between A/C switch assembly harness connector and A/C auto amp. harness connector.

| A/C switch assembly | | A/C auto amp. | | Continuity |
|---------------------|----------|---------------|----------|------------|
| Connector | Terminal | Connector | Terminal | |
| M142 | 12 | M50 | 24 | Yes |

Is the inspection result normal?

- YES >> GO TO 2.
- NO >> Repair harness or connector.

2. CHECK COMMUNICATION SIGNAL CIRCUIT (A/C AUTO AMP. → A/C SWITCH ASSEMBLY) FOR SHORT

Check continuity between A/C switch assembly harness connector and ground.

B2796 CONTROL COMMUNICATION

< DTC/CIRCUIT DIAGNOSIS >

[AUTOMATIC AIR CONDITIONING]

| A/C switch assembly | | — | Continuity |
|---------------------|----------|--------|------------|
| Connector | Terminal | | |
| M142 | 12 | Ground | No |

Is the inspection result normal?

YES >> GO TO 3.

NO >> Repair harness or connector.

3. CHECK COMMUNICATION SIGNAL CIRCUIT (A/C SWITCH ASSEMBLY → A/C AUTO AMP.) FOR OPEN

Check continuity between A/C switch assembly harness connector and A/C auto amp. harness connector.

| A/C switch assembly | | A/C auto amp. | | Continuity |
|---------------------|----------|---------------|----------|------------|
| Connector | Terminal | Connector | Terminal | |
| M142 | 11 | M50 | 4 | Yes |

Is the inspection result normal?

YES >> GO TO 4.

NO >> Repair harness or connector.

4. CHECK COMMUNICATION SIGNAL CIRCUIT (A/C SWITCH ASSEMBLY → A/C AUTO AMP.) FOR SHORT

Check continuity between A/C switch assembly harness connector and ground.

| A/C switch assembly | | — | Continuity |
|---------------------|----------|--------|------------|
| Connector | Terminal | | |
| M142 | 11 | Ground | No |

Is the inspection result normal?

YES >> Replace A/C auto amp. Refer to [HAC-92, "Removal and Installation"](#).

NO >> Repair harness or connector.

B27B0 A/C AUTO AMP.

< DTC/CIRCUIT DIAGNOSIS >

[AUTOMATIC AIR CONDITIONING]

B27B0 A/C AUTO AMP.

DTC Description

INFOID:000000012876791

DTC DETECTION LOGIC

NOTE:

- If DTC is displayed along with DTC U1000, first perform the trouble diagnosis for DTC U1000. Refer to [HAC-45, "DTC Description"](#).
- If DTC is displayed along with DTC U1010, first perform the trouble diagnosis for DTC U1010. Refer to [HAC-46, "DTC Description"](#).

| DTC No. | CONSULT screen terms (Trouble diagnosis content) | DTC detection condition | |
|---------|---|-------------------------|-----------------------------|
| | | Diagnosis condition | When Ignition switch is ON. |
| B27B0 | A/C AUTO AMP. (A/C auto amp.) | Signal (terminal) | - |
| | | Threshold | - |
| | | Diagnosis delay time | - |
| | | | |

POSSIBLE CAUSE

A/C auto amp.

FAIL-SAFE

—

DTC CONFIRMATION PROCEDURE

1.PERFORM DTC CONFIRMATION PROCEDURE

CONSULT

1. Turn ignition switch ON.
2. Select "Self Diagnostic Result" mode of "HVAC".
3. Check DTC.

Is DTC detected?

- YES >> Refer to [HAC-69, "Diagnosis Procedure"](#).
 NO >> Inspection End.

Diagnosis Procedure

INFOID:000000012876792

1.PERFORM SELF DIAGNOSTIC

CONSULT

1. Turn ignition switch ON.
2. Select "Self Diagnostic Result" mode of "HVAC".
3. Touch "ERASE".
4. Turn ignition switch OFF.
5. Turn ignition switch ON.
6. Perform "DTC CONFIRMATION PROCEDURE". Refer to [HAC-69, "DTC Description"](#).

Is DTC detected again?

- YES >> Replace A/C auto amp. Refer to [HAC-92, "Removal and Installation"](#).
 NO >> Inspection End.

POWER SUPPLY AND GROUND CIRCUIT

< DTC/CIRCUIT DIAGNOSIS >

[AUTOMATIC AIR CONDITIONING]

POWER SUPPLY AND GROUND CIRCUIT

A/C AUTO AMP.

A/C AUTO AMP. : Diagnosis Procedure

INFOID:000000012876793

Regarding Wiring Diagram information, refer to [HAC-29. "Wiring Diagram"](#).

1. CHECK FUSE

Check fuses [No. 14 and 29, located in the fuse block (J/B)].

NOTE:

Refer to [PG-99. "Terminal Arrangement"](#).

Is the inspection result normal?

YES >> GO TO 2.

NO >> Replace the blown fuse after repairing the affected circuit.

2. CHECK A/C AUTO AMP. POWER SUPPLY

1. Turn ignition switch OFF.
2. Disconnect A/C auto amp. connector.
3. Check voltage between A/C auto amp. harness connector and ground.

| + | | - | Voltage | | |
|---------------|----------|--------|--------------------------|-----------------|-----------------|
| A/C auto amp. | | | Ignition switch position | | |
| Connector | Terminal | | OFF | ACC | ON |
| M50 | 23 | Ground | Approx. 0 V | Approx. 0 V | Battery voltage |
| | 3 | | Battery voltage | Battery voltage | Battery voltage |

Is the inspection result normal?

YES >> GO TO 3.

NO >> Repair harness or connector between A/C auto amp. and fuse block (J/B).

3. CHECK A/C AUTO AMP. GROUND CIRCUIT

1. Turn ignition switch OFF.
2. Check continuity between A/C auto amp. harness connector and ground.

| A/C auto amp. | | — | Continuity |
|---------------|----------|--------|------------|
| Connector | Terminal | | |
| M50 | 2 | Ground | Yes |
| | 22 | | |

Is the inspection result normal?

YES >> Inspection End.

NO >> Repair harness or connector.

AIR MIX DOOR MOTOR (DRIVER SIDE)

AIR MIX DOOR MOTOR (DRIVER SIDE) : Diagnosis Procedure

INFOID:000000012876794

Regarding Wiring Diagram information, refer to [HAC-29. "Wiring Diagram"](#).

1. CHECK AIR MIX DOOR MOTOR LH POWER SUPPLY

1. Turn ignition switch ON.
2. Check voltage between air mix door motor LH harness connector and ground.

POWER SUPPLY AND GROUND CIRCUIT

< DTC/CIRCUIT DIAGNOSIS >

[AUTOMATIC AIR CONDITIONING]

| + | | - | Voltage (Approx.) |
|-----------------------|----------|--------|----------------------|
| Air mix door motor LH | | | |
| Connector | Terminal | | |
| M155 | 1 | Ground | Battery voltage |

Is the inspection result normal?

- YES >> GO TO 2.
- NO >> GO TO 4.

2. CHECK AIR MIX DOOR MOTOR LH GROUND CIRCUIT

1. Turn ignition switch OFF.
2. Disconnect air mix door motor LH connector.
3. Check continuity between air mix door motor LH harness connector and ground.

| Air mix door motor LH | | - | Continuity |
|-----------------------|----------|--------|------------|
| Connector | Terminal | | |
| M155 | 2 | Ground | Yes |

Is the inspection result normal?

- YES >> GO TO 3.
- NO >> Repair harness or connector.

3. CHECK INSTALLATION OF AIR MIX DOOR MOTOR LH

Check air mix door motor LH is properly installed. Refer to [HAC-98, "Exploded View"](#).

Is the inspection result normal?

- YES >> Replace air mix door motor LH. Refer to [HAC-99, "AIR MIX DOOR MOTOR : Removal and Installation - \(LH\)"](#).
- NO >> Repair or replace malfunctioning part.

4. CHECK AIR MIX DOOR MOTOR LH POWER SUPPLY CIRCUIT

1. Turn ignition switch OFF.
2. Disconnect air mix door motor LH connector and A/C auto amp. connector.
3. Check continuity between air mix door motor LH harness connector and A/C auto amp. harness connector.

| Air mix door motor LH | | A/C auto amp. | | Continuity |
|-----------------------|----------|---------------|----------|------------|
| Connector | Terminal | Connector | Terminal | |
| M155 | 1 | M50 | 17 | Yes |

Is the inspection result normal?

- YES >> Replace A/C auto amp. Refer to [HAC-92, "Removal and Installation"](#).
- NO >> Repair harness or connector.

AIR MIX DOOR MOTOR (PASSENGER SIDE)

AIR MIX DOOR MOTOR (PASSENGER SIDE) : Diagnosis Procedure

INFOID:000000012876795

Regarding Wiring Diagram information, refer to [HAC-29, "Wiring Diagram"](#).

1. CHECK AIR MIX DOOR MOTOR RH POWER SUPPLY

1. Turn ignition switch ON.
2. Check voltage between air mix door motor RH harness connector and ground.

POWER SUPPLY AND GROUND CIRCUIT

< DTC/CIRCUIT DIAGNOSIS >

[AUTOMATIC AIR CONDITIONING]

| + | | - | Voltage (Approx.) |
|-----------------------|----------|--------|----------------------|
| Air mix door motor RH | | | |
| Connector | Terminal | | |
| M156 | 1 | Ground | Battery voltage |

Is the inspection result normal?

- YES >> GO TO 2.
- NO >> GO TO 4.

2. CHECK AIR MIX DOOR MOTOR RH GROUND CIRCUIT

1. Turn ignition switch OFF.
2. Disconnect air mix door motor RH connector.
3. Check continuity between air mix door motor RH harness connector and ground.

| Air mix door motor RH | | - | Continuity |
|-----------------------|----------|--------|------------|
| Connector | Terminal | | |
| M156 | 2 | Ground | Yes |

Is the inspection result normal?

- YES >> GO TO 3.
- NO >> Repair harness or connector.

3. CHECK INSTALLATION OF AIR MIX DOOR MOTOR RH

Check air mix door motor RH is properly installed. Refer to [HAC-98. "Exploded View"](#).

Is the inspection result normal?

- YES >> Replace air mix door motor RH. Refer to [HAC-99. "AIR MIX DOOR MOTOR : Removal and Installation - \(RH\)"](#).
- NO >> Repair or replace malfunctioning part.

4. CHECK AIR MIX DOOR MOTOR RH POWER SUPPLY CIRCUIT

1. Turn ignition switch OFF.
2. Disconnect air mix door motor RH connector and A/C auto amp. connector.
3. Check continuity between air mix door motor RH harness connector and A/C auto amp. harness connector.

| Air mix door motor RH | | A/C auto amp. | | Continuity |
|-----------------------|----------|---------------|----------|------------|
| Connector | Terminal | Connector | Terminal | |
| M156 | 1 | M50 | 17 | Yes |

Is the inspection result normal?

- YES >> Replace A/C auto amp. Refer to [HAC-92. "Removal and Installation"](#).
- NO >> Repair harness or connector.

MODE DOOR MOTOR

MODE DOOR MOTOR : Diagnosis Procedure

INFOID:000000012876796

Regarding Wiring Diagram information, refer to [HAC-29. "Wiring Diagram"](#).

1. CHECK MODE DOOR MOTOR POWER SUPPLY

1. Turn ignition switch ON.
2. Check voltage between mode door motor harness connector and ground.

POWER SUPPLY AND GROUND CIRCUIT

< DTC/CIRCUIT DIAGNOSIS >

[AUTOMATIC AIR CONDITIONING]

| + | | - | Voltage (Approx.) |
|-----------------|----------|--------|----------------------|
| Mode door motor | | | |
| Connector | Terminal | | |
| M154 | 1 | Ground | Battery voltage |

Is the inspection result normal?

- YES >> GO TO 2.
- NO >> GO TO 4.

2. CHECK MODE DOOR MOTOR (FRONT) GROUND CIRCUIT

1. Turn ignition switch OFF.
2. Disconnect mode door motor connector.
3. Check continuity between mode door motor harness connector and ground.

| Mode door motor | | — | Continuity |
|-----------------|----------|--------|------------|
| Connector | Terminal | | |
| M154 | 2 | Ground | Yes |

Is the inspection result normal?

- YES >> GO TO 3.
- NO >> Repair harness or connector.

3. CHECK INSTALLATION OF MODE DOOR MOTOR CONTROL LINKAGE

Check mode door motor control linkage is properly installed. Refer to [HAC-98, "Exploded View"](#).

Is the inspection result normal?

- YES >> Replace mode door motor. Refer to [HAC-99, "MODE DOOR MOTOR : Removal and Installation"](#).
- NO >> Repair or replace malfunctioning part.

4. CHECK MODE DOOR MOTOR POWER SUPPLY CIRCUIT

1. Turn ignition switch OFF.
2. Disconnect mode door motor connector and A/C auto amp. connector.
3. Check continuity between mode door motor harness connector and A/C auto amp. harness connector.

| Mode door motor | | A/C auto amp. | | Continuity |
|-----------------|----------|---------------|----------|------------|
| Connector | Terminal | Connector | Terminal | |
| M154 | 1 | M50 | 17 | Yes |

Is the inspection result normal?

- YES >> Replace A/C auto amp. Refer to [HAC-92, "Removal and Installation"](#).
- NO >> Repair harness or connector.

INTAKE DOOR MOTOR

INTAKE DOOR MOTOR : Diagnosis Procedure

INFOID:000000012876797

Regarding Wiring Diagram information, refer to [HAC-29, "Wiring Diagram"](#).

1. CHECK INTAKE MODE DOOR MOTOR POWER SUPPLY

1. Turn ignition switch ON.
2. Check voltage between intake mode door motor harness connector and ground.

POWER SUPPLY AND GROUND CIRCUIT

< DTC/CIRCUIT DIAGNOSIS >

[AUTOMATIC AIR CONDITIONING]

| + | | - | Voltage (Approx.) |
|------------------------|----------|--------|----------------------|
| Intake mode door motor | | | |
| Connector | Terminal | | |
| M153 | 1 | Ground | Battery voltage |

Is the inspection result normal?

- YES >> GO TO 2.
- NO >> GO TO 4.

2. CHECK INTAKE MODE DOOR MOTOR GROUND CIRCUIT

1. Turn ignition switch OFF.
2. Disconnect intake mode door motor connector.
3. Check continuity between intake mode door motor harness connector and ground.

| Intake mode door motor | | - | Continuity |
|------------------------|----------|--------|------------|
| Connector | Terminal | | |
| M153 | 2 | Ground | Yes |

Is the inspection result normal?

- YES >> GO TO 3.
- NO >> Repair harness or connector.

3. CHECK INSTALLATION OF INTAKE MODE DOOR MOTOR

Check intake mode door motor is properly installed. Refer to [HAC-98. "Exploded View"](#).

Is the inspection result normal?

- YES >> Replace intake mode door motor. Refer to [HAC-100. "INTAKE DOOR MOTOR : Removal and Installation"](#).
- NO >> Repair or replace malfunctioning part.

4. CHECK INTAKE MODE DOOR MOTOR POWER SUPPLY CIRCUIT

1. Turn ignition switch OFF.
2. Disconnect intake mode door motor connector and A/C auto amp. connector.
3. Check continuity between intake mode door motor harness connector and A/C auto amp. harness connector.

| Intake mode door motor | | A/C auto amp. | | Continuity |
|------------------------|----------|---------------|----------|------------|
| Connector | Terminal | Connector | Terminal | |
| M153 | 1 | M50 | 17 | Yes |

Is the inspection result normal?

- YES >> Replace A/C auto amp. Refer to [HAC-92. "Removal and Installation"](#).
- NO >> Repair harness or connector.

DOOR MOTOR

< DTC/CIRCUIT DIAGNOSIS >

[AUTOMATIC AIR CONDITIONING]

DOOR MOTOR

Diagnosis Procedure

INFOID:0000000012876798

Regarding Wiring Diagram information, refer to [HAC-29. "Wiring Diagram"](#).

1. CHECK EACH DOOR MOTOR POWER SUPPLY

1. Turn ignition switch ON.
2. Check voltage between intake door motor harness connector and ground.

| + | | - | Voltage (Approx.) |
|-------------------|----------|--------|----------------------|
| Intake door motor | | | |
| Connector | Terminal | | |
| M153 | 1 | Ground | Battery voltage |

Is the inspection result normal?

YES >> GO TO 2.

NO >> GO TO 3.

2. CHECK EACH DOOR MOTOR GROUND CIRCUIT

1. Turn ignition switch OFF.
2. Disconnect intake door motor connector.
3. Check continuity between intake door motor harness connector and ground.

| Intake door motor | | — | Continuity |
|-------------------|----------|--------|------------|
| Connector | Terminal | | |
| M153 | 2 | Ground | Yes |

Is the inspection result normal?

YES >> Inspection End.

NO >> Repair harness or connector.

3. CHECK EACH DOOR MOTOR POWER SUPPLY CIRCUIT FOR OPEN

1. Disconnect A/C auto amp. connector.
2. Check continuity between intake door motor harness connector and A/C auto amp. harness connector.

| Intake door motor | | A/C auto amp. | | Continuity |
|-------------------|----------|---------------|----------|------------|
| Connector | Terminal | Connector | Terminal | |
| M153 | 1 | M50 | 17 | Yes |

Is the inspection result normal?

YES >> GO TO 4.

NO >> Repair harness or connector.

4. CHECK EACH DOOR MOTOR POWER SUPPLY CIRCUIT FOR SHORT

1. Disconnect following connectors.
 - Air mix door motor LH
 - Air mix door motor RH
 - Mode door motor
2. Check continuity between intake door motor harness connector and ground.

| Intake door motor | | — | Continuity |
|-------------------|----------|--------|------------|
| Connector | Terminal | | |
| M153 | 1 | Ground | No |

A
B
C
D
E
F
G
H
J
K
L
M
N
O
P

HAC

DOOR MOTOR

< DTC/CIRCUIT DIAGNOSIS >

[AUTOMATIC AIR CONDITIONING]

Is the inspection result normal?

YES >> Replace A/C auto amp. Refer to [HAC-92, "Removal and Installation"](#).

NO >> Repair harness or connector.

DOOR MOTOR COMMUNICATION CIRCUIT

< DTC/CIRCUIT DIAGNOSIS >

[AUTOMATIC AIR CONDITIONING]

DOOR MOTOR COMMUNICATION CIRCUIT

Diagnosis Procedure

INFOID:000000012876799

Regarding Wiring Diagram information, refer to [HAC-29. "Wiring Diagram"](#).

NOTE:

If all of door motor DTCs are detected, check this circuit.

1. CHECK EACH DOOR MOTOR COMMUNICATION SIGNAL

1. Turn ignition switch ON.
2. Check output waveform between A/C auto amp. harness connector and ground with the oscilloscope.

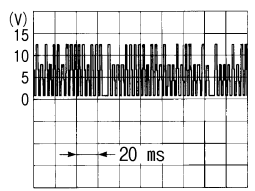
| + | | - | Output waveform |
|---------------|----------|--------|---|
| A/C auto amp. | | | |
| Connector | Terminal | | |
| M50 | 16 | Ground |  <p style="text-align: right;">SJIA1453J</p> |

Is the inspection result normal?

- YES >> GO TO 2.
 NO >> GO TO 3.

2. CHECK EACH DOOR MOTOR COMMUNICATION SIGNAL CIRCUIT FOR OPEN

1. Turn ignition switch OFF.
2. Disconnect A/C auto amp. connector and intake door motor connector.
3. Check continuity between A/C auto amp. harness connector and intake door motor harness connector.

| A/C auto amp. | | Intake door motor | | Continuity |
|---------------|----------|-------------------|----------|------------|
| Connector | Terminal | Connector | Terminal | |
| M50 | 16 | M153 | 3 | Yes |

Is the inspection result normal?

- YES >> Inspection End.
 NO >> Repair harness or connector.

3. CHECK EACH DOOR MOTOR COMMUNICATION SIGNAL CIRCUIT FOR SHORT

1. Disconnect following connectors.
 - Air mix door motor LH
 - Air mix door motor RH
 - Mode door motor
2. Check continuity between A/C auto amp. harness connector and ground.

| A/C auto amp. | | - | Continuity |
|---------------|----------|--------|------------|
| Connector | Terminal | | |
| M50 | 16 | Ground | No |

Is the inspection result normal?

- YES >> Replace A/C auto amp. Refer to [HAC-92. "Removal and Installation"](#).
 NO >> Repair harness or connector.

A
B
C
D
E
F
G
H
J
K
L
M
N
O
P

HAC

FRONT BLOWER MOTOR

< DTC/CIRCUIT DIAGNOSIS >

[AUTOMATIC AIR CONDITIONING]

FRONT BLOWER MOTOR

Diagnosis Procedure

INFOID:000000012876800

Regarding Wiring Diagram information, refer to [HAC-29. "Wiring Diagram"](#).

1. CHECK FUSE

1. Turn ignition switch OFF.
2. Check 15A fuses [Nos. 17 and 27, located in fuse block (J/B)].

NOTE:

Refer to [PG-99. "Terminal Arrangement"](#).

Is the inspection result normal?

- YES >> GO TO 2.
NO >> Replace the blown fuse after repairing the affected circuit.

2. CHECK FRONT BLOWER MOTOR POWER SUPPLY

1. Disconnect front blower motor connector.
2. Turn ignition switch ON.
3. Check voltage between front blower motor harness connector and ground.

| + | | - | Voltage |
|--------------------|----------|--------|-----------------|
| Front blower motor | | | |
| Connector | Terminal | | |
| M112 | 4 | Ground | Battery voltage |

Is the inspection result normal?

- YES >> GO TO 3.
NO >> GO TO 6.

3. CHECK FRONT BLOWER MOTOR GROUND CIRCUIT

1. Turn ignition switch OFF.
2. Check continuity between front blower motor harness connector and ground.

| Front blower motor | | - | Continuity |
|--------------------|----------|--------|------------|
| Connector | Terminal | | |
| M112 | 1 | Ground | Yes |

Is the inspection result normal?

- YES >> GO TO 4.
NO >> Repair harness or connector.

4. CHECK FRONT BLOWER MOTOR CONTROL SIGNAL CIRCUIT

1. Disconnect A/C auto amp. connector.
2. Check continuity between front blower motor harness connector and A/C auto amp. harness connector.

| Front blower motor | | A/C auto amp. | | Continuity |
|--------------------|----------|---------------|----------|------------|
| Connector | Terminal | Connector | Terminal | |
| M112 | 3 | M50 | 18 | Yes |

Is the inspection result normal?

- YES >> GO TO 5.
NO >> Repair the harness or connector.

5. CHECK FRONT BLOWER MOTOR CONTROL SIGNAL

FRONT BLOWER MOTOR

[AUTOMATIC AIR CONDITIONING]

< DTC/CIRCUIT DIAGNOSIS >

1. Reconnect front blower motor connector and A/C auto amp. connector.
2. Turn ignition switch ON.
3. Operate MODE switch to set air outlet to VENT.
4. Change fan speed from Lo to Hi, and check duty ratios between front blower motor harness connector and ground by using an oscilloscope.

NOTE:

Calculate drive signal duty ratio as shown in the figure.
T2 = Approx. 1.6 ms

| Front blower motor | | Condition | Duty ratio (Approx.) |
|--------------------|----------|------------------------------|----------------------|
| Connector | Terminal | Fan speed (manual) VENT mode | |
| M112 | 3 | 1st | 25 % |
| | | 2nd | 31 % |
| | | 3rd | 37 % |
| | | 4th | 45 % |
| | | 5th | 55 % |
| | | 6th | 65 % |
| | | 7th | 77 % |

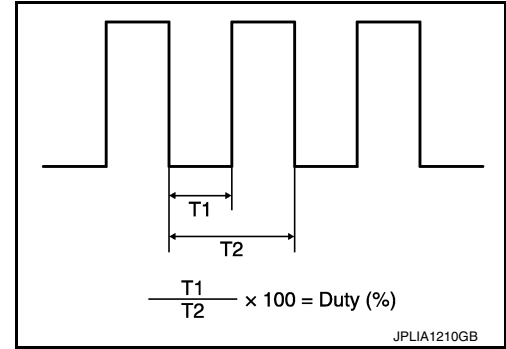

Is the inspection result normal?

- YES >> Replace front blower motor. Refer to [VTL-15, "BLOWER MOTOR : Removal and Installation"](#).
NO >> Replace A/C auto amp. Refer to [HAC-92, "Removal and Installation"](#).

6.CHECK FRONT BLOWER MOTOR RELAY GROUND CIRCUIT

1. Turn ignition switch OFF.
2. Check continuity between fuse block (J/B) harness connector and ground.

| Fuse block (J/B) | | — | Continuity |
|------------------|----------|--------|------------|
| Connector | Terminal | | |
| M68 | 13R | Ground | Yes |

Is the inspection result normal?

- YES >> GO TO 7.
NO >> Repair harness or connector.

7.CHECK FRONT BLOWER RELAY

Check front blower motor relay. Refer to [HAC-79, "Component Inspection \(Front Blower Motor Relay\)"](#).

Is the inspection result normal?

- YES >> Repair harness or connector between front blower motor and fuse block (J/B).
NO >> Replace front blower relay.

Component Inspection (Front Blower Motor)

INFOID:0000000012876801

1.CHECK FRONT BLOWER MOTOR

1. Connect battery voltage to terminal 1 of front blower motor.
2. Connect ground to terminal 2 of front blower motor.

Does the front blower fan operate?

- YES >> Intermittent incident. Refer to [GI-42, "Intermittent Incident"](#).
NO >> Replace front blower motor. Refer to [VTL-15, "BLOWER MOTOR : Removal and Installation"](#).

Component Inspection (Front Blower Motor Relay)

INFOID:0000000012876802

1.CHECK BLOWER RELAY

1. Turn ignition switch OFF.
2. Remove front blower motor relay.

FRONT BLOWER MOTOR

[AUTOMATIC AIR CONDITIONING]

< DTC/CIRCUIT DIAGNOSIS >

3. Check continuity between front blower motor relay terminals 3 and 5 when voltage is supplied between terminals 1 and 2.

| Terminals | | Voltage | Continuity |
|-----------|---|---------|------------|
| 3 | 5 | ON | Yes |
| | | OFF | No |

Is the inspection result normal?

- YES >> Inspection End.
NO >> Replace front blower motor relay.

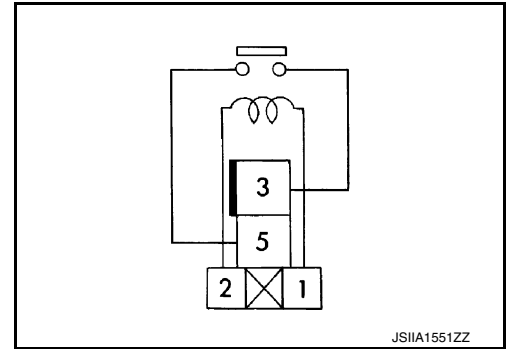

MAGNET CLUTCH

< DTC/CIRCUIT DIAGNOSIS >

[AUTOMATIC AIR CONDITIONING]

MAGNET CLUTCH

Component Function Check

INFOID:000000012876803

1.CHECK MAGNET CLUTCH OPERATION

Perform auto active test of IPDM E/R. Refer to [PCS-9, "Diagnosis Description"](#).

Does it operate normally?

- YES >> Inspection End.
NO >> Refer to [HAC-81, "Diagnosis Procedure"](#).

Diagnosis Procedure

INFOID:000000012876804

Regarding Wiring Diagram information, refer to [HAC-29, "Wiring Diagram"](#).

1.CHECK FUSE

1. Turn ignition switch OFF.
2. Check 10A fuse (No. 53, located in IPDM E/R).

NOTE:

Refer to [PG-102, "IPDM E/R Terminal Arrangement"](#).

Is the inspection result normal?

- YES >> GO TO 2.
NO >> Replace the blown fuse after repairing the affected circuit.

2.CHECK MAGNET CLUTCH POWER SUPPLY CIRCUIT

1. Disconnect A/C compressor connector and IPDM E/R connector.
2. Check continuity between A/C compressor harness connector and IPDM E/R harness connector.

| A/C compressor | | IPDM E/R | | Continuity |
|----------------|----------|-----------|----------|------------|
| Connector | Terminal | Connector | Terminal | |
| F3 | 1 | F19 | 56 | Yes |

Is the inspection result normal?

- YES >> GO TO 3.
NO >> Repair harness or connector.

3.CHECK MAGNET CLUTCH GROUND CIRCUIT

1. Disconnect A/C compressor connector.
2. Check continuity between A/C compressor harness connector and ground.

| A/C compressor | | — | Continuity |
|----------------|----------|--------|------------|
| Connector | Terminal | | |
| F3 | 2 | Ground | Yes |

Is the inspection result normal?

- YES >> GO TO 4.
NO >> Repair harness or connector.

4.CHECK MAGNET CLUTCH

Directly apply battery voltage to the magnet clutch. Check operation visually and by sound.

Does it operate normally?

- YES >> Replace IPDM E/R. Refer to [PCS-36, "Removal and Installation"](#).
NO >> Replace magnet clutch. Refer to [HA-30, "MAGNET CLUTCH : Removal and Installation of Compressor Clutch"](#).

A
B
C
D
E
F
G
H
J
K
L
M
N
O
P

HAC

ECV (ELECTRICAL CONTROL VALVE)

< DTC/CIRCUIT DIAGNOSIS >

[AUTOMATIC AIR CONDITIONING]

ECV (ELECTRICAL CONTROL VALVE)

Diagnosis Procedure

INFOID:000000012876805

Regarding Wiring Diagram information, refer to [HAC-29, "Wiring Diagram"](#).

1. CHECK ECV (ELECTRICAL CONTROL VALVE) POWER SUPPLY

1. Turn ignition switch OFF.
2. Disconnect A/C compressor connector.
3. Turn ignition switch ON.
4. Check voltage between A/C compressor harness connector and ground.

| + | | - | Voltage |
|----------------|----------|--------|-----------------|
| A/C compressor | | | |
| Connector | Terminal | | |
| F4 | 4 | Ground | Battery voltage |

Is the inspection result normal?

YES >> GO TO 3.

NO >> GO TO 2.

2. CHECK FUSE

1. Turn ignition switch OFF.
2. Check 10 A fuse [No. 5, located in fuse block (J/B)]. Refer to [PG-99, "Terminal Arrangement"](#).

Is the inspection result normal?

YES >> Repair harness or connector.

NO >> Replace the blown fuse after repairing the affected circuit.

3. CHECK ECV CONTROL SIGNAL CIRCUIT FOR OPEN

1. Turn ignition switch OFF.
2. Disconnect A/C auto amp. connector.
3. Check continuity between A/C compressor harness connector and A/C auto amp. harness connector.

| A/C compressor | | A/C auto amp. | | Continuity |
|----------------|----------|---------------|----------|------------|
| Connector | Terminal | Connector | Terminal | |
| F4 | 3 | M50 | 40 | Yes |

Is the inspection result normal?

YES >> GO TO 4.

NO >> Repair harness or connector.

4. CHECK ECV CONTROL SIGNAL CIRCUIT FOR SHORT

Check continuity between A/C compressor harness connector and ground.

| A/C compressor | | - | Continuity |
|----------------|----------|--------|------------|
| Connector | Terminal | | |
| F4 | 3 | Ground | No |

Is the inspection result normal?

YES >> GO TO 5.

NO >> Repair harness or connector.

5. CHECK ECV

Check ECV. Refer to [HAC-83, "Component Inspection"](#).

ECV (ELECTRICAL CONTROL VALVE)

[AUTOMATIC AIR CONDITIONING]

< DTC/CIRCUIT DIAGNOSIS >

Is the inspection result normal?

YES >> GO TO 6.

NO >> Replace A/C compressor. Refer to [HA-29. "COMPRESSOR : Removal and Installation"](#).

6. CHECK INTERMITTENT INCIDENT

Refer to [GI-42. "Intermittent Incident"](#).

Is the inspection result normal?

YES >> Replace A/C auto amp. Refer to [HAC-92. "Removal and Installation"](#).

NO >> Repair or replace malfunctioning parts.

Component Inspection

INFOID:0000000012876806

1. CHECK ECV (ELECTRICAL CONTROL VALVE)

1. Turn ignition switch OFF.
2. Disconnect A/C compressor connector.
3. Check continuity between A/C compressor connector F4 terminals.

| Terminals | | Condition | Resistance (kΩ) |
|-----------|---|----------------------|-----------------|
| | | Temperature: °C (°F) | |
| 3 | 4 | 20 (68) | 10.1 – 11.1 |

Is the inspection result normal?

YES >> Inspection End.

NO >> Replace A/C compressor. Refer to [HA-29. "COMPRESSOR : Removal and Installation"](#).

A
B
C
D
E
F
G
H
J
K
L
M
N
O
P

HAC

AUTOMATIC AIR CONDITIONING SYSTEM

< SYMPTOM DIAGNOSIS >

[AUTOMATIC AIR CONDITIONING]

SYMPTOM DIAGNOSIS

AUTOMATIC AIR CONDITIONING SYSTEM

Diagnosis Chart By Symptom

INFOID:0000000012876807

NOTE:

Perform self-diagnoses with CONSULT before performing the symptom diagnosis. If DTC is detected, perform the corresponding diagnosis.

| Symptom | Corresponding malfunction part | Reference |
|--|---|---|
| <ul style="list-style-type: none"> • Air conditioning does not activate. • Air conditioning cannot be controlled. • Operation status of air conditioning is not indicated on display. | <ul style="list-style-type: none"> • A/C auto amp. ignition power supply circuit • A/C control (A/C auto amp.) | HAC-70. "A/C AUTO AMP. : Diagnosis Procedure" |
| <ul style="list-style-type: none"> • Air outlet does not change. • Mode door motor does not operate normally. | <ul style="list-style-type: none"> • Circuit between mode door motor and A/C auto amp. • Mode door motor control linkage • Mode door motor • A/C auto amp. | HAC-72. "MODE DOOR MOTOR : Diagnosis Procedure" |
| <ul style="list-style-type: none"> • Discharge air temperature of driver side does not change. • Air mix door motor LH does not operate normally. | <ul style="list-style-type: none"> • Circuit between air mix door motor LH and A/C auto amp. • Air mix door motor LH installation condition • Air mix door motor LH • A/C auto amp. | HAC-70. "AIR MIX DOOR MOTOR (DRIVER SIDE) : Diagnosis Procedure" |
| <ul style="list-style-type: none"> • Discharge air temperature of passenger side does not change. • Air mix door motor RH does not operate normally. | <ul style="list-style-type: none"> • Circuit between air mix door motor RH and A/C auto amp. • Air mix door motor RH installation condition • Air mix door motor RH • A/C auto amp. | HAC-71. "AIR MIX DOOR MOTOR (PASSENGER SIDE) : Diagnosis Procedure" |
| <ul style="list-style-type: none"> • Intake door does not change. • Intake door motor does not operate normally. | <ul style="list-style-type: none"> • Circuit between intake door motor and A/C auto amp. • Intake door motor control linkage • Intake door motor • A/C auto amp. | HAC-73. "INTAKE DOOR MOTOR : Diagnosis Procedure" |
| <p>All door motors do not operate normally.</p> | <ul style="list-style-type: none"> • Each door motor power supply and ground circuit • A/C auto amp. | HAC-75. "Diagnosis Procedure" |
| <p>Front blower motor operation is malfunctioning.</p> | <ul style="list-style-type: none"> • Power supply system of front blower motor • Circuit between front blower motor and A/C auto amp. • Front blower motor • A/C auto amp. | HAC-78. "Diagnosis Procedure" |
| <p>Compressor does not operate.</p> | <ul style="list-style-type: none"> • Circuit between magnet clutch and IPDM E/R • Magnet clutch • IPDM E/R (A/C relay) • Circuit between ECM and refrigerant pressure sensor • Refrigerant pressure sensor • CAN communication circuit • A/C auto amp. | HAC-89. "Diagnosis Procedure" |

AUTOMATIC AIR CONDITIONING SYSTEM

< SYMPTOM DIAGNOSIS >

[AUTOMATIC AIR CONDITIONING]

| Symptom | | Corresponding malfunction part | Reference |
|--|-------------------------------------|--|---|
| <ul style="list-style-type: none"> Insufficient cooling. No cool air comes out. (Air flow volume is normal.) | | <ul style="list-style-type: none"> Magnet clutch control system Drive belt slipping Refrigerant cycle ECV (electrical control valve) Air leakage from each duct A/C auto amp. connection recognition signal circuit Temperature setting trimmer (front) | HAC-86. "Diagnosis Procedure" |
| <ul style="list-style-type: none"> Insufficient heating. No warm air comes out. (Air flow volume is normal.) | | <ul style="list-style-type: none"> Engine cooling system Heater hose Heater core Air leakage from each duct Temperature setting trimmer (front) | HAC-88. "Diagnosis Procedure" |
| Noise is heard when front air conditioning system operates. | During compressor operation | Refrigerant cycle | HA-19. "Symptom Table" |
| | During front blower motor operation | <ul style="list-style-type: none"> Mixing any foreign object in front blower motor Front blower motor fan breakage Front blower motor rotation inferiority | HAC-79. "Component Inspection (Front Blower Motor)" |
| <ul style="list-style-type: none"> Memory function does not operate. Setting temperature is not memorized. | | <ul style="list-style-type: none"> Battery power supply system of A/C auto amp. A/C auto amp. | HAC-70. "A/C AUTO AMP. : Diagnosis Procedure" |

A
B
C
D
E
F
G
H
J
K
L
M
N
O
P

HAC

INSUFFICIENT COOLING**Description**

INFOID:000000012876808

Symptom

- Insufficient cooling
- No cool air comes out. (Air flow volume is normal.)

Diagnosis Procedure

INFOID:000000012876809

NOTE:

Perform self-diagnoses with CONSULT before performing symptom diagnosis. If any DTC is detected, perform the corresponding diagnosis.

1.CHECK MAGNET CLUTCH OPERATION

1. Turn ignition switch ON.
2. Operate fan switch.
3. Press A/C switch.
4. Check that A/C indicator turns ON. Check visually and by sound that compressor operates.
5. Press A/C switch again.
6. Check that A/C indicator turns OFF. Check that compressor stops.

Is the inspection result normal?

- YES >> GO TO 2.
 NO >> Perform diagnosis of "COMPRESSOR DOES NOT OPERATE" in "SYMPTOM DIAGNOSIS".
 Refer to [HAC-89. "Diagnosis Procedure"](#).

2.CHECK DRIVE BELT

Check tension of drive belt. Refer to [EM-14. "Checking Drive Belt"](#).

Is the inspection result normal?

- YES >> GO TO 3.
 NO >> Adjust or replace drive belt depending on the inspection results.

3.CHECK REFRIGERANT CYCLE

Connect recovery/recycling recharging equipment to the vehicle and perform pressure inspection with gauge. Refer to [HA-17. "Symptom Table"](#).

Is the inspection result normal?

- YES >> GO TO 4.
 NO >> Repair or replace parts depending on the inspection results.

4.CHECK AIR LEAKAGE FROM EACH DUCT

Check duct and nozzle, etc. of the front air conditioning system for leakage.

Is the inspection result normal?

- YES >> GO TO 5.
 NO >> Repair or replace parts depending on the inspection results.

5.CHECK AMBIENT TEMPERATURE DISPLAY

Check that there is not much difference between actual ambient temperature and indicated temperature on information display in combination meter.

Is the inspection result normal?

- YES >> GO TO 6.
 NO >> Perform diagnosis for the A/C auto amp. connection recognition signal circuit. Refer to [HAC-50. "Diagnosis Procedure"](#).

6.CHECK SETTING OF TEMPERATURE SETTING TRIMMER (FRONT)

1. Check setting value of temperature setting trimmer (front). Refer to [HAC-43. "Temperature Setting Trimmer \(Front\)"](#).
2. Check that temperature setting trimmer (front) is set to "+ direction".

NOTE:

INSUFFICIENT COOLING

< SYMPTOM DIAGNOSIS >

[AUTOMATIC AIR CONDITIONING]

The control temperature can be set with the setting of the temperature setting trimmer (front).

3. Set difference between set temperature and control temperature to "0".

Is inspection result normal?

YES >> Inspection End.

NO >> Replace A/C auto amp. Refer to [HAC-92, "Removal and Installation"](#).

A
B
C
D
E
F
G
H
J
K
L
M
N
O
P

HAC

INSUFFICIENT HEATING

Description

INFOID:000000012876810

Symptom

- Insufficient heating
- No warm air comes out. (Air flow volume is normal.)

Diagnosis Procedure

INFOID:000000012876811

NOTE:

Perform self-diagnoses with on board diagnosis and CONSULT before performing symptom diagnosis. If DTC is detected, perform the corresponding diagnosis.

1.CHECK COOLING SYSTEM

1. Check engine coolant level and check leakage. Refer to [CO-8. "System Inspection"](#).
2. Check reservoir tank cap. Refer to [CO-8. "System Inspection"](#).
3. Check water flow sounds of the engine coolant. Refer to [CO-8. "System Inspection"](#).

Is the inspection result normal?

- YES >> GO TO 2.
NO >> Refill engine coolant and repair or replace parts depending on the inspection results.

2.CHECK HEATER HOSE

Check installation of heater hose visually or by touching.

Is the inspection result normal?

- YES >> GO TO 3.
NO >> Repair or replace parts depending on the inspection results.

3.CHECK HEATER CORE

1. Check temperature of inlet hose and outlet hose of front heater core.
2. Check that inlet side of heater core is hot and the outlet side is slightly lower than/almost equal to the inlet side.

CAUTION:

Always perform the temperature inspection in a short period of time because the engine coolant temperature is very hot.

Is the inspection result normal?

- YES >> GO TO 4.
NO >> Replace heater core. Refer to [HA-43. "Removal and Installation"](#).

4.CHECK AIR LEAKAGE FROM EACH DUCT

Check duct and nozzle, etc. of front air conditioning system for air leakage.

Is the inspection result normal?

- YES >> GO TO 5.
NO >> Repair or replace parts depending on the inspection results.

5.CHECK SETTING OF TEMPERATURE SETTING TRIMMER (FRONT)

1. Check setting value of temperature setting trimmer (front). Refer to [HAC-43. "Temperature Setting Trimmer \(Front\)"](#).
2. Check that temperature setting trimmer (front) is set to "– direction".

NOTE:

The control temperature can be set by the temperature setting trimmer (front).

3. Set difference between the set temperature and control temperature to "0".

Are the symptoms solved?

- YES >> Inspection End.
NO >> Replace A/C auto amp. Refer to [HAC-92. "Removal and Installation"](#).

COMPRESSOR DOES NOT OPERATE

< SYMPTOM DIAGNOSIS >

[AUTOMATIC AIR CONDITIONING]

COMPRESSOR DOES NOT OPERATE

Description

INFOID:0000000012876812

Symptom: Compressor does not operate.

Diagnosis Procedure

INFOID:0000000012876813

NOTE:

- Perform self-diagnoses with CONSULT before performing symptom diagnosis. If DTC is detected, perform the corresponding diagnosis.
- Check that refrigerant system is properly charged. If refrigerant amount is below the proper amount, perform inspection of refrigerant leakage.

1. CHECK MAGNET CLUTCH OPERATION

Check magnet clutch. Refer to [HAC-81, "Component Function Check"](#).

Does it operate normally?

- YES >> GO TO 2.
NO >> Repair or replace malfunctioning parts.

2. CHECK REFRIGERANT PRESSURE SENSOR

Check refrigerant pressure sensor. Refer to [EC-556, "Component Function Check"](#).

Is the inspection result normal?

- YES >> GO TO 3.
NO >> Repair or replace malfunctioning parts.

3. CHECK A/C AUTO AMP. OUTPUT SIGNAL

CONSULT

1. Select "Data Monitor" mode of "HVAC"
2. Select "COMP REQ SIG" and "FAN REQ SIG".
3. Check that the function operates normally according to the following conditions:

| Monitor item | Condition | | Status |
|--------------|--------------------|-----|--------|
| COMP REQ SIG | A/C switch | ON | On |
| | | OFF | Off |
| FAN REQ SIG | Front blower motor | ON | On |
| | | OFF | Off |

Is the inspection result normal?

- YES >> GO TO 4.
NO >> Replace A/C auto amp. Refer to [HAC-92, "Removal and Installation"](#).

4. CHECK ECM INPUT SIGNAL

CONSULT

1. Select "Data Monitor" mode of "ECM"
2. Select "AIR COND SIG" and "HEATER FAN SW".
3. Check that the function operates normally according to the following conditions:

| Monitor item | Condition | | Status |
|---------------|--------------------|-----|--------|
| AIR COND SIG | A/C switch | ON | On |
| | | OFF | Off |
| HEATER FAN SW | Front blower motor | ON | On |
| | | OFF | Off |

Is the inspection result normal?

- YES >> GO TO 5.
NO >> Check CAN communication system. Refer to [LAN-21, "Trouble Diagnosis Flow Chart"](#).

A

B

C

D

E

F

G

H

HAC

J

K

L

M

N

O

P

COMPRESSOR DOES NOT OPERATE

< SYMPTOM DIAGNOSIS >

[AUTOMATIC AIR CONDITIONING]

5. CHECK IPDM E/R INPUT SIGNAL

CONSULT

1. Start engine.
2. Select "Data Monitor" mode of "IPDM E/R"
3. Select "AC COMP REQ".
4. Check that the function operates normally according to the following conditions:

| Monitor item | Condition | | Status |
|--------------|------------|-----|--------|
| AC COMP REQ | A/C switch | ON | On |
| | | OFF | Off |

Is the inspection result normal?

- YES >> Inspection End.
NO >> Check CAN communication system. Refer to [LAN-21, "Trouble Diagnosis Flow Chart"](#).

REMOVAL AND INSTALLATION

A/C SWITCH ASSEMBLY

Removal and Installation

INFOID:0000000012876814

REMOVAL

1. Remove the cluster lid D. Refer to [JP-23. "Removal and Installation"](#).
2. Remove the screws (A) and release pawls.
○: Pawl
3. Disconnect the harness connector (B) from the A/C switch assembly and remove.

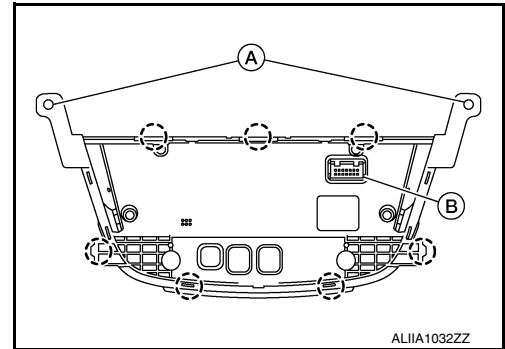

INSTALLATION

Installation is in the reverse order of removal.

A
B
C
D
E
F
G
H
I
J
K
L
M
N
O
P

HAC

A/C AUTO AMP.

Exploded View

INFOID:000000012876815

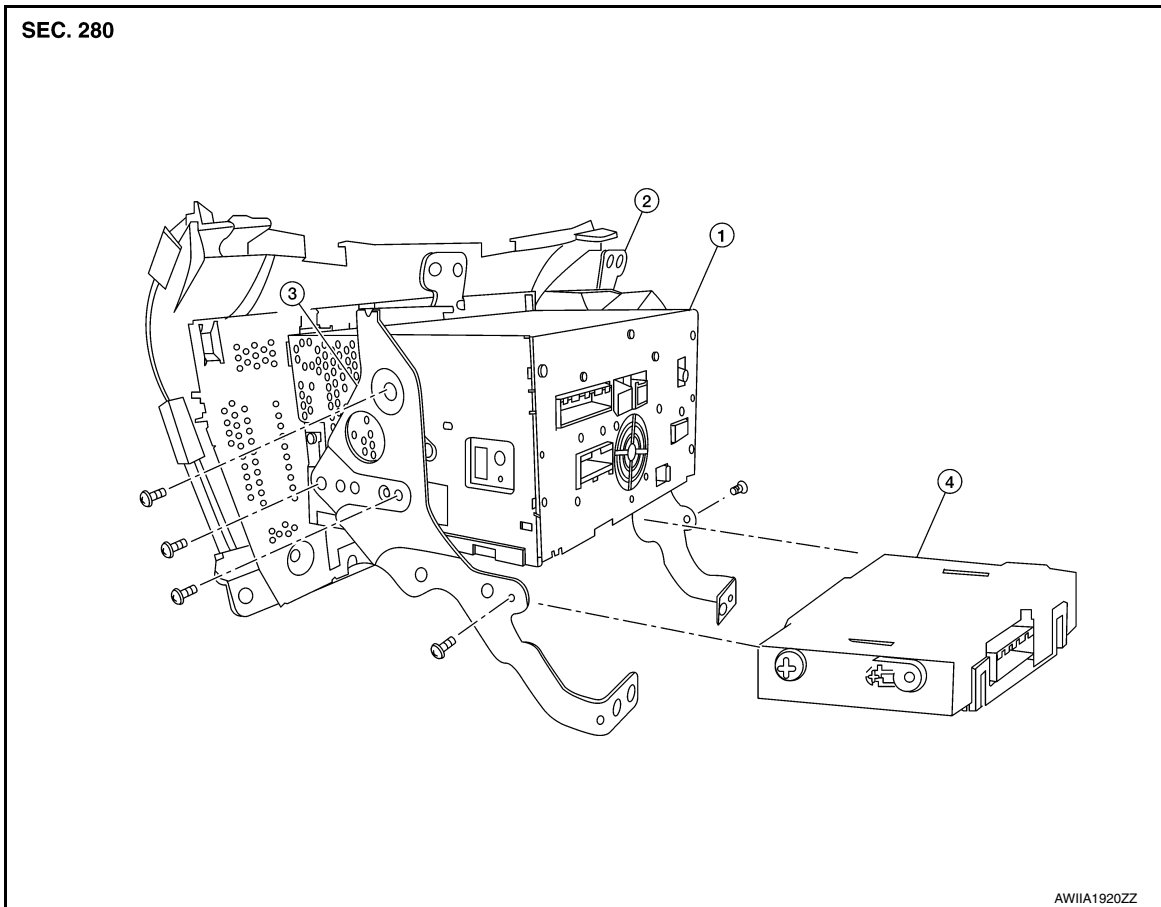

1. Audio unit or AV control unit 2. Audio unit or AV control unit bracket (LH) 3. Audio unit or AV control unit bracket (RH)
4. A/C auto amp.

Removal and Installation

INFOID:000000012876816

REMOVAL

NOTE:

Before replacing A/C auto amp., perform "Before Replace ECU" of "Read / Write Configuration" to save or print current vehicle specification. Refer to [HAC-41. "Description"](#).

1. Remove the audio unit (display audio system), AV control unit (navigation with Bose) or AV control unit (navigation without Bose). Refer to [AV-62. "Removal and Installation"](#) audio unit (display audio system), [AV-198. "Removal and Installation"](#) AV control unit (navigation with Bose) or [AV-198. "Removal and Installation"](#) AV control unit (navigation without Bose).
2. Remove the screws and one of the AV control unit brackets.
3. Remove the A/C auto amp.

INSTALLATION

CAUTION:

Be sure to perform "After Replace ECU" of "Read / Write Configuration" or "Manual Configuration" when replacing A/C auto amp. Refer to [HAC-41. "Description"](#).

Installation is in the reverse order of removal.

AMBIENT SENSOR

< REMOVAL AND INSTALLATION >

[AUTOMATIC AIR CONDITIONING]

AMBIENT SENSOR

Removal and Installation

INFOID:000000012876817

REMOVAL

1. Remove the front bumper fascia. Refer to [EXT-25. "Removal and Installation"](#).
2. Disconnect the harness connector (A) from the ambient sensor (1).
3. Release the ambient sensor clip and then remove the ambient sensor.

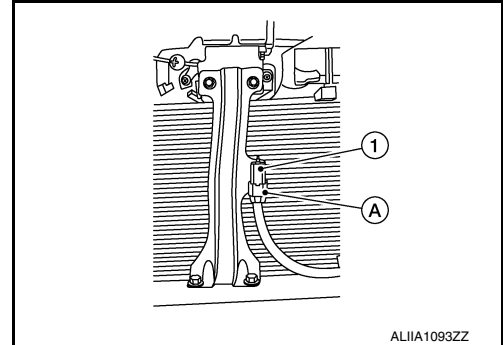

INSTALLATION

Installation is in the reverse order of removal.

A

B

C

D

E

F

G

H

HAC

J

K

L

M

N

O

P

IN-VEHICLE SENSOR

< REMOVAL AND INSTALLATION >

[AUTOMATIC AIR CONDITIONING]

IN-VEHICLE SENSOR

Removal and Installation

INFOID:000000012876818

REMOVAL

1. Remove the instrument lower panel LH. Refer to [IP-24. "Removal and Installation"](#).
2. Remove the screw (A) and in-vehicle sensor (1).

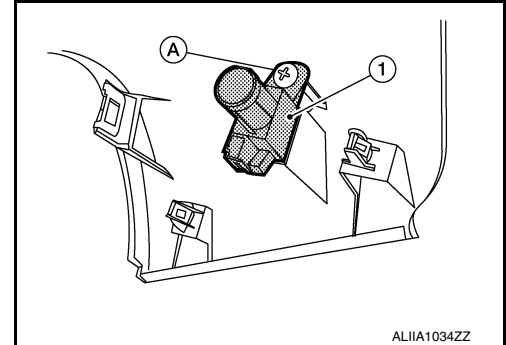

INSTALLATION

Installation is in the reverse order of removal.

CAUTION:

Make sure that the aspirator hose is securely attached to the in-vehicle sensor when installing the instrument lower panel LH.

SUNLOAD SENSOR

< REMOVAL AND INSTALLATION >

[AUTOMATIC AIR CONDITIONING]

SUNLOAD SENSOR

Removal and Installation

INFOID:000000012876819

REMOVAL

1. Release the pawls using a suitable tool, then remove sunload sensor (1) from the instrument panel (2).
- : Pawl
2. Disconnect the harness connector from the sunload sensor.

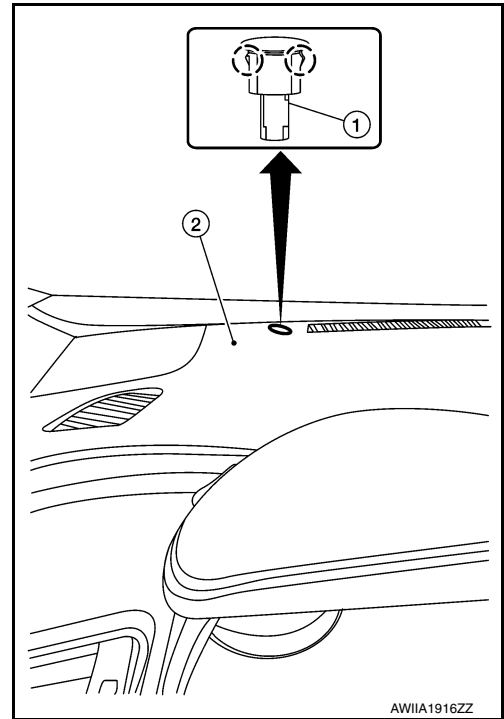

INSTALLATION

Installation is in the reverse order of removal.

A
B
C
D
E
F
G
H

HAC

J
K
L
M
N
O
P

INTAKE SENSOR

< REMOVAL AND INSTALLATION >

[AUTOMATIC AIR CONDITIONING]

INTAKE SENSOR

Removal and Installation

INFOID:000000012876820

REMOVAL

1. Remove the evaporator assembly from the heating and cooling unit. Refer to [HA-44, "Removal and Installation"](#).
2. Remove the intake sensor (1) from the evaporator (2).

NOTE:

Mark the position of the intake sensor for installation.

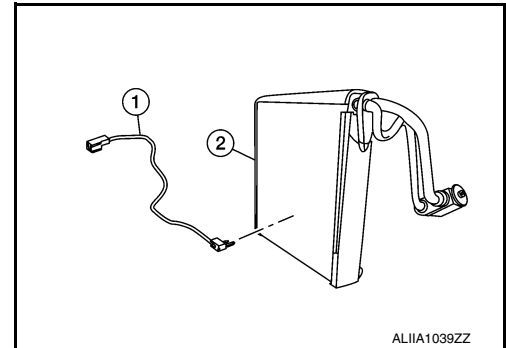

INSTALLATION

Installation is in the reverse order of removal.

REFRIGERANT PRESSURE SENSOR

< REMOVAL AND INSTALLATION >

[AUTOMATIC AIR CONDITIONING]

REFRIGERANT PRESSURE SENSOR

Removal and Installation

INFOID:0000000012876821

REMOVAL

1. Discharge the refrigerant. Refer to [HA-22. "Recycle Refrigerant"](#).
2. Remove the front bumper fascia assembly. Refer to [EXT-25. "Removal and Installation"](#).
3. Remove the horn assembly (LOW). Refer to [HRN-6. "Removal and Installation"](#).
4. Remove the air guide (RH). Refer to [HA-36. "Exploded View"](#).
5. Disconnect the harness connector from the refrigerant pressure sensor.
6. Remove nut and refrigerant pressure sensor (1).

CAUTION:

Cap or wrap the opening of the refrigerant pressure sensor with suitable material such as vinyl tape to avoid the entry of air.

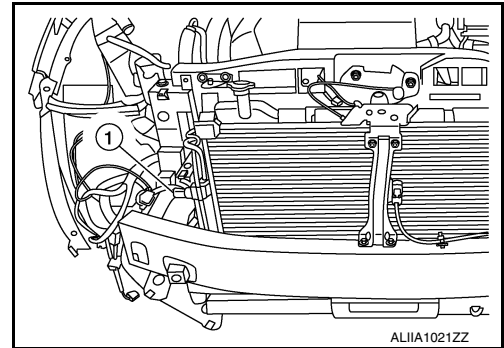

INSTALLATION

Installation is in the reverse order of removal.

CAUTION:

- Do not reuse the O-ring.
- Apply A/C oil to the O-ring of the refrigerant pressure sensor for installation.
- After charging the refrigerant, check for leaks. Refer to [HA-20. "Leak Test"](#).

A
B
C
D
E
F
G
H
J
K
L
M
N
O
P

HAC

DOOR MOTOR

< REMOVAL AND INSTALLATION >

[AUTOMATIC AIR CONDITIONING]

DOOR MOTOR

Exploded View

INFOID:000000012876822

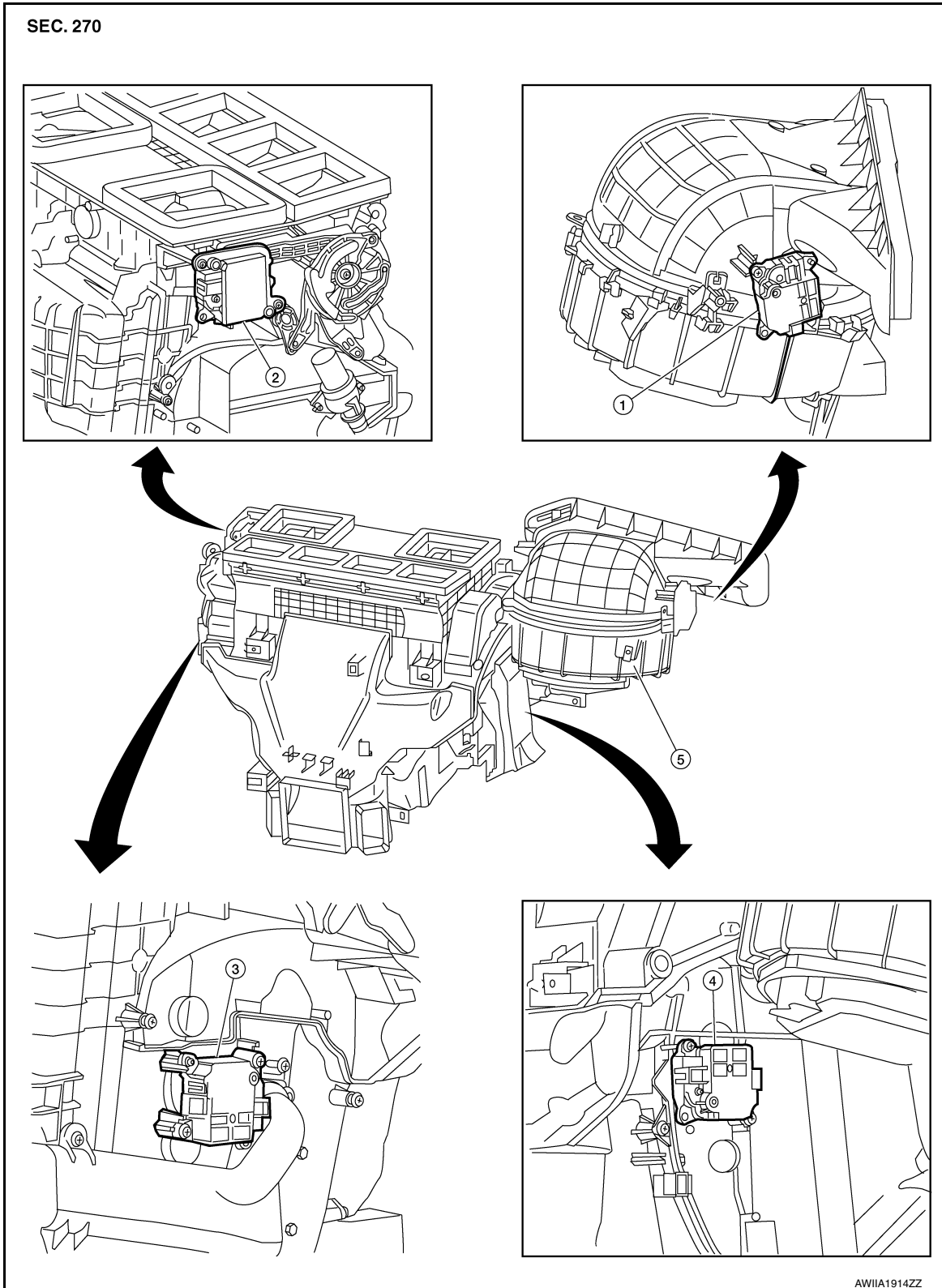

1. Intake door motor

2. Mode door motor

3. Air mix door motor (LH)

4. Air mix door motor (RH)

5. Heating and cooling unit assembly

DOOR MOTOR

< REMOVAL AND INSTALLATION >

[AUTOMATIC AIR CONDITIONING]

MODE DOOR MOTOR

MODE DOOR MOTOR : Removal and Installation

INFOID:000000012876823

REMOVAL

1. Remove the center console side finisher (LH). Refer to [IP-19, "Exploded View"](#).
2. Remove the instrument lower panel LH. Refer to [IP-24, "Removal and Installation"](#).
3. Remove the screws (A) and the front foot duct (LH) (1).
4. Remove the mode door motor screws.
5. Disconnect the harness connector from the mode door motor and remove.

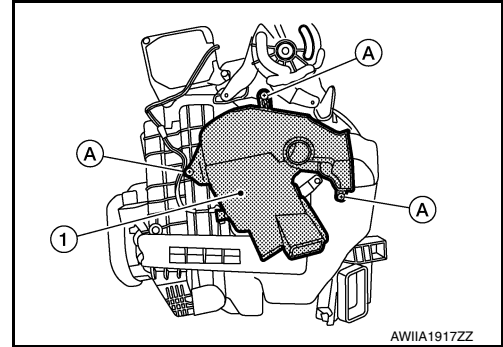

INSTALLATION

Installation is in the reverse order of removal.

AIR MIX DOOR MOTOR

AIR MIX DOOR MOTOR : Removal and Installation - (LH)

INFOID:000000012876824

REMOVAL

1. Remove the center console side finisher (LH). Refer to [IP-19, "Exploded View"](#).
2. Remove the instrument lower panel LH. Refer to [IP-24, "Removal and Installation"](#).
3. Remove the screws (A) and the front foot duct (LH) (1).
4. Remove the air mix door motor (LH) screws.
5. Disconnect the harness connector from the air mix door motor (driver side) and remove.

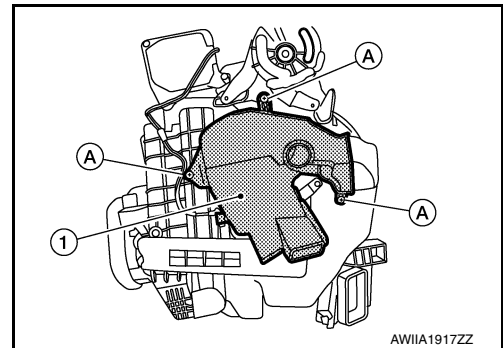

INSTALLATION

Installation is in the reverse order of removal.

AIR MIX DOOR MOTOR : Removal and Installation - (RH)

INFOID:000000012876825

REMOVAL

1. Remove the center console side finisher (RH). Refer to [IP-19, "Exploded View"](#).
2. Remove the glove box assembly. Refer to [IP-25, "Removal and Installation"](#).

A
B
C
D
E
F
G
H
HAC
J
K
L
M
N
O
P

DOOR MOTOR

< REMOVAL AND INSTALLATION >

[AUTOMATIC AIR CONDITIONING]

3. Remove the screws (A) and front foot duct (RH) (1).
4. Remove the air mix door motor (RH) screws.
5. Disconnect the harness connector from the air mix door motor (passenger side) and remove.

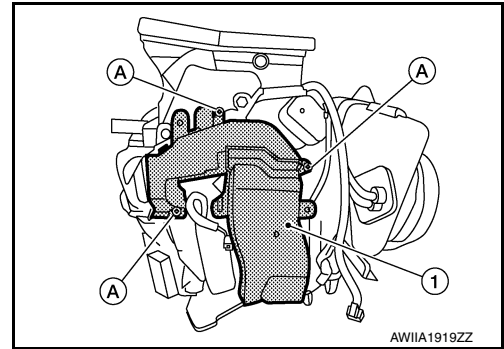

INSTALLATION

Installation is in the reverse order of removal.

INTAKE DOOR MOTOR

INTAKE DOOR MOTOR : Removal and Installation

INFOID:0000000012876826

REMOVAL

1. Remove the glove box assembly. Refer to [JP-25. "Removal and Installation"](#).
2. Remove the intake door motor screws.
3. Disconnect the harness connector from the intake door motor and remove.

INSTALLATION

Installation is in the reverse order of removal.