

SECTION **PWO**
POWER OUTLET

A
B
C
D
E
F
G
H
I
J
K
L
N
O
P

CONTENTS

PRECAUTION	2	WIRING DIAGRAM	5
PRECAUTIONS	2	POWER SOCKET	5
Precaution for Supplemental Restraint System (SRS) "AIR BAG" and "SEAT BELT PRE-TEN- SIONER"	2	Wiring Diagram	5
Precaution for Work	2	REMOVAL AND INSTALLATION	8
PREPARATION	3	POWER SOCKET	8
PREPARATION	3	Removal and Installation	8
Special Service Tool	3	SERVICE DATA AND SPECIFICATIONS (SDS)	9
SYSTEM DESCRIPTION	4	SERVICE DATA AND SPECIFICATIONS (SDS)	9
COMPONENT PARTS	4	Power Socket	9
Component Parts Location	4		

PWO

PRECAUTIONS

< PRECAUTION >

PRECAUTION

PRECAUTIONS

Precaution for Supplemental Restraint System (SRS) "AIR BAG" and "SEAT BELT PRE-TENSIONER"

INFOID:000000013388301

The Supplemental Restraint System such as "AIR BAG" and "SEAT BELT PRE-TENSIONER", used along with a front seat belt, helps to reduce the risk or severity of injury to the driver and front passenger for certain types of collision. Information necessary to service the system safely is included in the SR and SB section of this Service Manual.

WARNING:

- To avoid rendering the SRS inoperative, which could increase the risk of personal injury or death in the event of a collision which would result in air bag inflation, it is recommended that all maintenance and repair be performed by an authorized NISSAN/INFINITI dealer.
- Improper repair, including incorrect removal and installation of the SRS, can lead to personal injury caused by unintentional activation of the system. For removal of Spiral Cable and Air Bag Module, see the SR section.
- Do not use electrical test equipment on any circuit related to the SRS unless instructed to in this Service Manual. SRS wiring harnesses can be identified by yellow and/or orange harnesses or harness connectors.

PRECAUTIONS WHEN USING POWER TOOLS (AIR OR ELECTRIC) AND HAMMERS

WARNING:

- When working near the Air Bag Diagnosis Sensor Unit or other Air Bag System sensors with the Ignition ON or engine running, DO NOT use air or electric power tools or strike near the sensor(s) with a hammer. Heavy vibration could activate the sensor(s) and deploy the air bag(s), possibly causing serious injury.
- When using air or electric power tools or hammers, always switch the Ignition OFF, disconnect the battery or batteries, and wait at least three minutes before performing any service.

Precaution for Work

INFOID:000000012874741

- When removing or disassembling each component, be careful not to damage or deform it. If a component may be subject to interference, be sure to protect it with a shop cloth.
- When removing (disengaging) components with a screwdriver or similar tool, be sure to wrap the component with a shop cloth or vinyl tape to protect it.
- Protect the removed parts with a shop cloth and prevent them from being dropped.
- Replace a deformed or damaged clip.
- If a part is specified as a non-reusable part, always replace it with a new one.
- Be sure to tighten bolts and nuts securely to the specified torque.
- After installation is complete, be sure to check that each part works properly.
- Follow the steps below to clean components:
 - Water soluble dirt:
 - Dip a soft cloth into lukewarm water, wring the water out of the cloth and wipe the dirty area.
 - Then rub with a soft, dry cloth.
 - Oily dirt:
 - Dip a soft cloth into lukewarm water with mild detergent (concentration: within 2 to 3%) and wipe the dirty area.
 - Then dip a cloth into fresh water, wring the water out of the cloth and wipe the detergent off.
 - Then rub with a soft, dry cloth.
 - Do not use organic solvent such as thinner, benzene, alcohol or gasoline.
 - For genuine leather seats, use a genuine leather seat cleaner.

PREPARATION

< PREPARATION >

PREPARATION

PREPARATION

Special Service Tool

INFOID:0000000012874742

The actual shape of the tools may differ from those illustrated here.

Tool number (TechMate No.) Tool name	Description
— (J-46534) Trim Tool Set	Removing trim components
— (J-42059) Power Outlet Remover	Removing power sockets

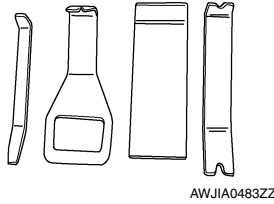

AWJIA0483ZZ

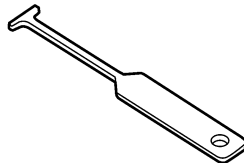

AWMIA1148GB

A
B
C
D
E
F
G
H
I
J
K
L
P

PWO

COMPONENT PARTS

< SYSTEM DESCRIPTION >

SYSTEM DESCRIPTION

COMPONENT PARTS

Component Parts Location

INFOID:000000012874743

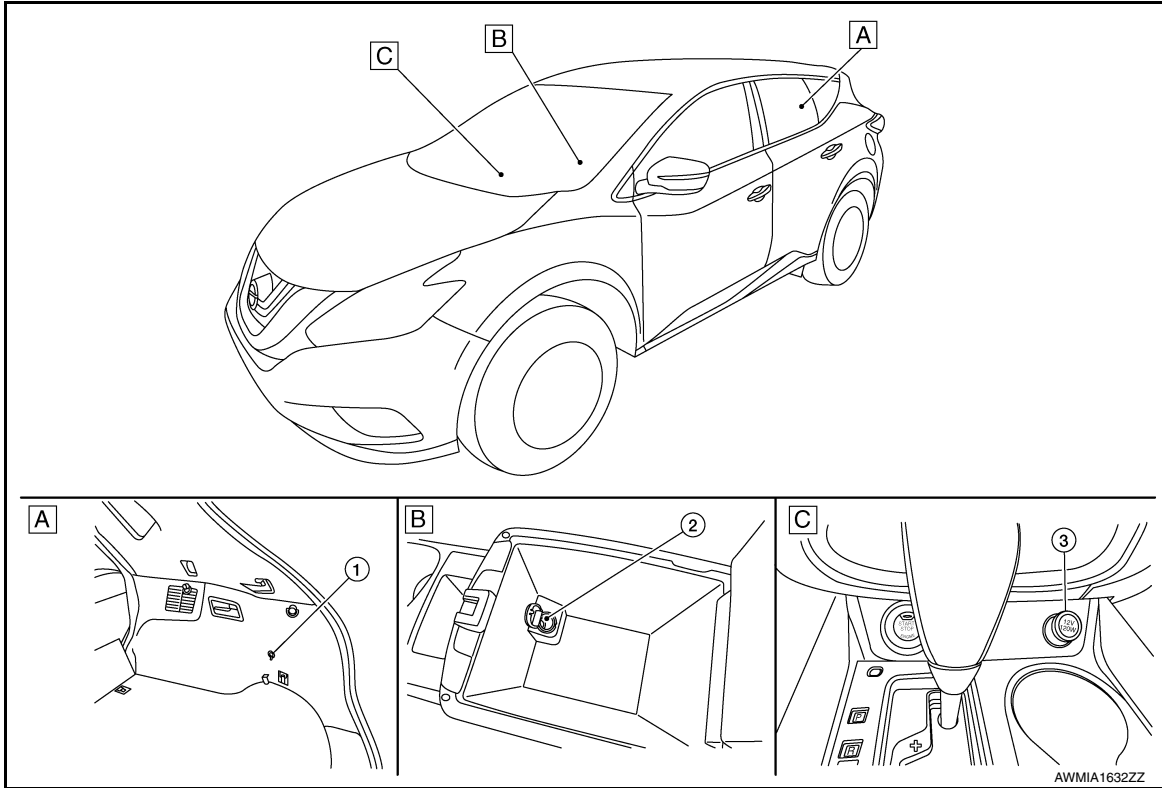

A. Luggage side lower finisher RH
1. Rear cargo power socket

B. Center console
2. Console power socket

C. Cluster lid C
3. Front power socket

POWER SOCKET

< WIRING DIAGRAM >

WIRING DIAGRAM

POWER SOCKET

Wiring Diagram

INFOID:0000000012874744

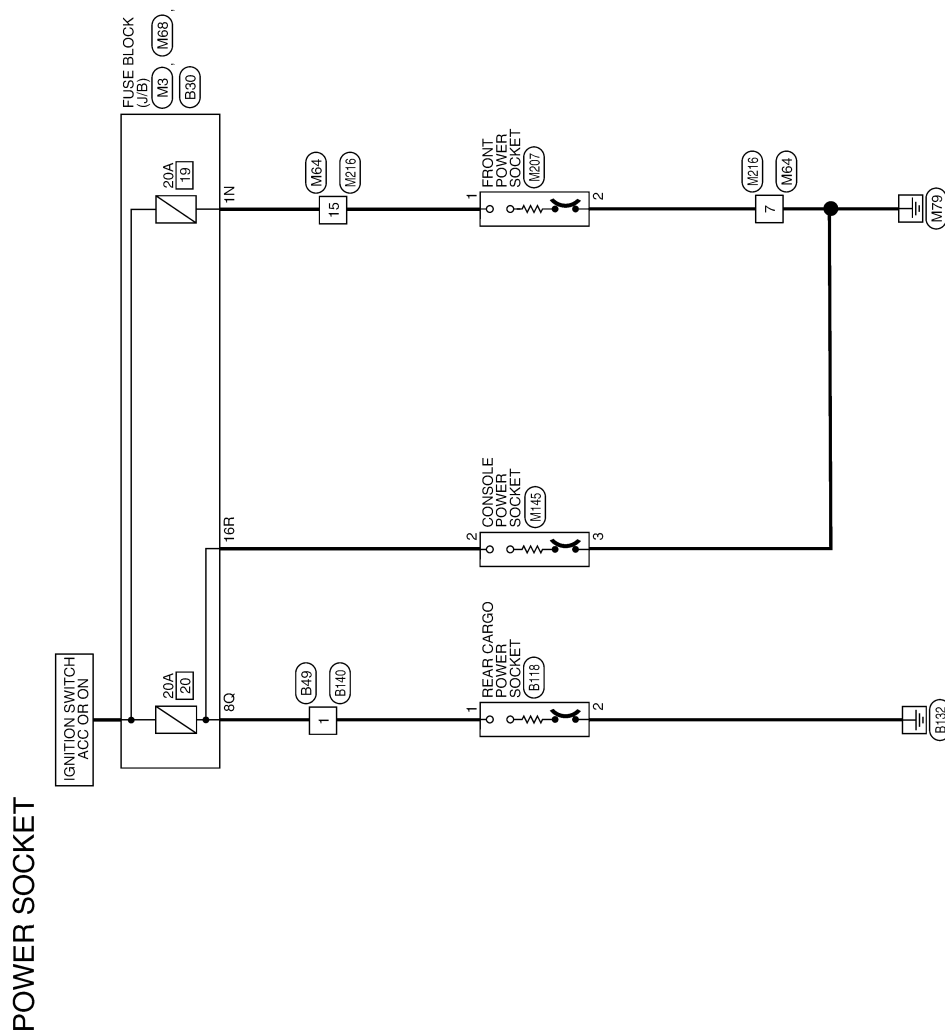

PWO

POWER SOCKET

< WIRING DIAGRAM >

POWER SOCKET CONNECTORS

Connector No.	M3
Connector Name	FUSE BLOCK (J/B)
Connector Type	CS06FW-M2
Connector Color	WHITE

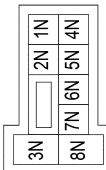

Terminal No.	1N	Color of Wire	LG	Signal Name	-
--------------	----	---------------	----	-------------	---

Connector No.	M64
Connector Name	WIRE TO WIRE
Connector Type	NS16MW-CS
Connector Color	WHITE

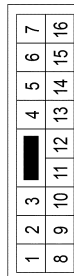
Terminal No.	7	Color of Wire	B	Signal Name	-
15	LG				

Connector No.	M68
Connector Name	FUSE BLOCK (J/B)
Connector Type	NS16FBR-CS
Connector Color	BROWN



Terminal No.	16R	Color of Wire	Y	Signal Name	-
--------------	-----	---------------	---	-------------	---

Connector No.	M145
Connector Name	CONSOLE POWER SOCKET
Connector Type	CAE01FB-CHA2
Connector Color	BLACK

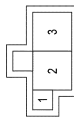
Terminal No.	2	Color of Wire	Y	Signal Name	-
3	B				

Connector No.	M207
Connector Name	FRONT POWER SOCKET
Connector Type	P02FB-Z
Connector Color	BLACK

Terminal No.	1	Color of Wire	LG	Signal Name	-
2	B				

Connector No.	M216
Connector Name	WIRE TO WIRE
Connector Type	NS16FW-CS
Connector Color	WHITE

Terminal No.	7	Color of Wire	B	Signal Name	-
--------------	---	---------------	---	-------------	---

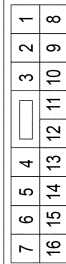
Terminal No.	15	Color of Wire	LG	Signal Name	-
--------------	----	---------------	----	-------------	---

Connector No.	B30
Connector Name	FUSE BLOCK (J/B)
Connector Type	NS08FW-CS
Connector Color	WHITE

Terminal No.	8Q	Color of Wire	L	Signal Name	-
--------------	----	---------------	---	-------------	---

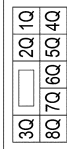
Connector No.	B49
Connector Name	WIRE TO WIRE
Connector Type	NS16FW-CS
Connector Color	WHITE

Terminal No.	1	Color of Wire	L	Signal Name	-
--------------	---	---------------	---	-------------	---

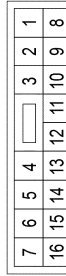
AAMIA3817GB

POWER SOCKET

< WIRING DIAGRAM >

A
B
C
D
E
F
G
H
I
J
K
L
N
O
P

Connector No.	B118
Connector Name	REAR CARGO POWER SOCKET
Connector Type	P02FB-Z
Connector Color	BLACK



Terminal No.	Color of Wire	Signal Name
1	L	-
2	GR	-

Connector No.	B140
Connector Name	WIRE TO WIRE
Connector Type	NS16MW-CS
Connector Color	WHITE

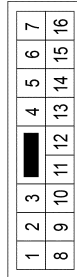

Terminal No.	Color of Wire	Signal Name
1	L	-

PWO

AAMIA3818GB

POWER SOCKET

< REMOVAL AND INSTALLATION >

REMOVAL AND INSTALLATION

POWER SOCKET

Removal and Installation

INFOID:000000012874745

FRONT CONSOLE POWER SOCKET, CONSOLE POWER SOCKET (IF EQUIPPED), or REAR CARGO POWER SOCKET (IF EQUIPPED)

NOTE:

If unable to use the Tool because of power socket location or access to the harness connector, then further removal of interior components may be required. Refer to [IP-19, "Exploded View"](#) (Front Console Power Socket), [IP-19, "Exploded View"](#) (Console Power Socket), or [INT-31, "LUGGAGE SIDE UPPER FINISHER: Removal and Installation"](#) (Rear Cargo Power Socket).

Removal

1. Remove the fuse for the power socket.
2. Insert one side of the Tool (A) into one of the square holes inside the power socket.

Tool number : — (J-42059)

3. Lift up the handle of the Tool until the other side snaps into the other square hole in the power socket.
4. Pull the power socket straight out with the Tool.

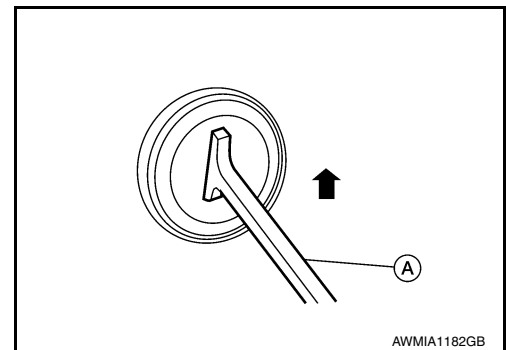

5. Disconnect the harness connector from the power socket.
6. Remove the ring from the power socket finisher while pressing the pawls.

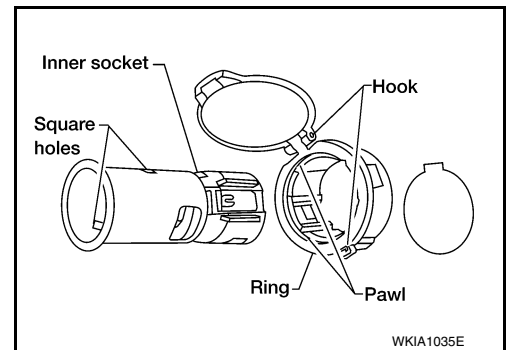

Installation

Installation is in the reverse order of removal.

NOTE:

Make sure to align the tab with the square notched area during installation.

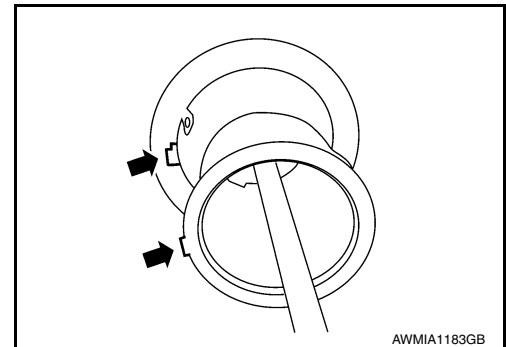

SERVICE DATA AND SPECIFICATIONS (SDS)

< SERVICE DATA AND SPECIFICATIONS (SDS)

SERVICE DATA AND SPECIFICATIONS (SDS)

SERVICE DATA AND SPECIFICATIONS (SDS)

Power Socket

INFOID:0000000012874746

Rated voltage	DC 12 V
Maximum electric capacity	120 W or less (Total)
Maximum current	10 A or less (Total)

A
B
C
D
E
F
G
H
I
J
K
L

PWO

N
O
P