

A
FL
C
D
E
F
G
H
J
K
L
M
N
O
P

SECTION **FL**

FUEL SYSTEM

CONTENTS

PRECAUTION	2	Removal and Installation	6
PRECAUTIONS	2	Disassembly and Assembly	9
General Precautions	2	Inspection	10
PREPARATION	3	FUEL TANK	11
PREPARATION	3	Exploded View	11
Special Service Tool	3	Removal and Installation	11
Commercial Service Tool	3	Inspection	13
PERIODIC MAINTENANCE	4	EVAP CANISTER	14
FUEL SYSTEM	4	Hydraulic Layout	14
Inspection	4	Exploded View	16
Quick Connector	4	Removal and Installation	16
REMOVAL AND INSTALLATION	5	Inspection	17
FUEL LEVEL SENSOR UNIT, FUEL FILTER AND FUEL PUMP ASSEMBLY	5	SERVICE DATA AND SPECIFICATIONS (SDS)	18
Exploded View	5	SERVICE DATA AND SPECIFICATIONS (SDS)	18
		Fuel Tank	18

PRECAUTIONS

< PRECAUTION >

PRECAUTION

PRECAUTIONS

General Precautions

INFOID:000000006937825

WARNING:

When replacing fuel line parts, be sure to observe the following.

- Put a “CAUTION: FLAMMABLE” sign in the workshop.
- Be sure to work in a well ventilated area and furnish workshop with a CO₂ fire extinguisher.
- Never smoke while servicing fuel system. Keep open flames and sparks away from the work area.

CAUTION:

- Use gasoline required by the regulations for octane number. Refer to [GI-28, "Fuel"](#).
- Before removing fuel line parts, perform out the following procedures:
 - Put drained fuel in an explosion-proof container and put the lid on securely. Keep the container in safe area.
 - Release fuel pressure from the fuel lines. Refer to [EC-134, "Work Procedure"](#).
 - Disconnect the battery cable from the negative terminal.
- Always replace O-ring and clamps with new ones.
- Never kink or twist tubes when they are being installed.
- Never tighten hose clamps excessively to avoid damaging hoses.
- After installing tubes, check there is no fuel leakage at connections in the following steps.
 - Apply fuel pressure to fuel lines with turning ignition switch “ON” (with engine stopped). Then check for fuel leakage at connections.
 - Start engine and rev it up and check for fuel leakage at connections.
- Use only a genuine NISSAN fuel filler cap as a replacement. If an incorrect fuel filler cap is used, the “MIL” may come on.
- For servicing “Evaporative Emission System” parts, refer to [EC-45, "EVAPORATIVE EMISSION SYSTEM : System Description"](#).
- For servicing “On Board Refueling Vapor Recovery (ORVR)” parts, refer to [EC-30, "On Board Refueling Vapor Recovery \(ORVR\)"](#).

PREPARATION

< PREPARATION >

PREPARATION

PREPARATION

Special Service Tool

INFOID:000000006937826

A

FL

The actual shapes of Kent-Moore tools may differ from those of special service tools illustrated here.

(Kent-Moore No.) Tool name	Description
(J-46211) Fuel tank lock ring wrench	Removing and installing fuel tank retainer

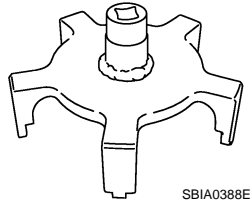

SBIA0388E

C

D

E

Commercial Service Tool

INFOID:000000006937827

Tool name	Description
Power tool	Loosening nuts and bolts

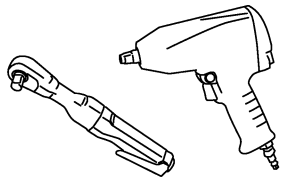

PBIC0190E

F

G

H

I

J

K

L

M

N

O

P

FUEL SYSTEM

< PERIODIC MAINTENANCE >

PERIODIC MAINTENANCE

FUEL SYSTEM

Inspection

INFOID:000000006937828

Inspect fuel lines, fuel filler cap, and fuel tank for improper attachment, leakage, cracks, damage, loose connections, chafing or deterioration.

- A : Engine
- B : Fuel line
- C : Fuel tank

If necessary, repair or replace damaged parts.

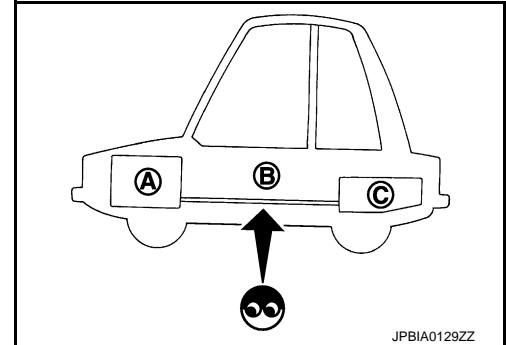

Quick Connector

INFOID:000000006937829

CAUTION:

- After connecting fuel tube quick connectors, check quick connectors are secure.

- 1 : Quick connector
- 2 : Retainer
- A : Hard tube (or the equivalent)
- B : Connection (cross-section)
- C : Resin tube
- D : To under floor fuel line
- E : To fuel tank
- F : Tab
- G : Disconnection

- Ensure that connector and resin tube never contact any adjacent parts.

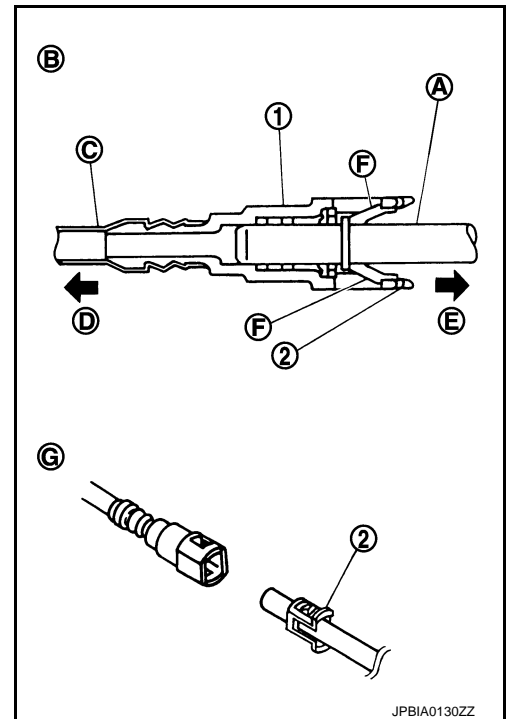

FUEL LEVEL SENSOR UNIT, FUEL FILTER AND FUEL PUMP ASSEMBLY

< REMOVAL AND INSTALLATION >

REMOVAL AND INSTALLATION

FUEL LEVEL SENSOR UNIT, FUEL FILTER AND FUEL PUMP ASSEMBLY

Exploded View

INFOID:000000006937830

A

FL

REMOVAL

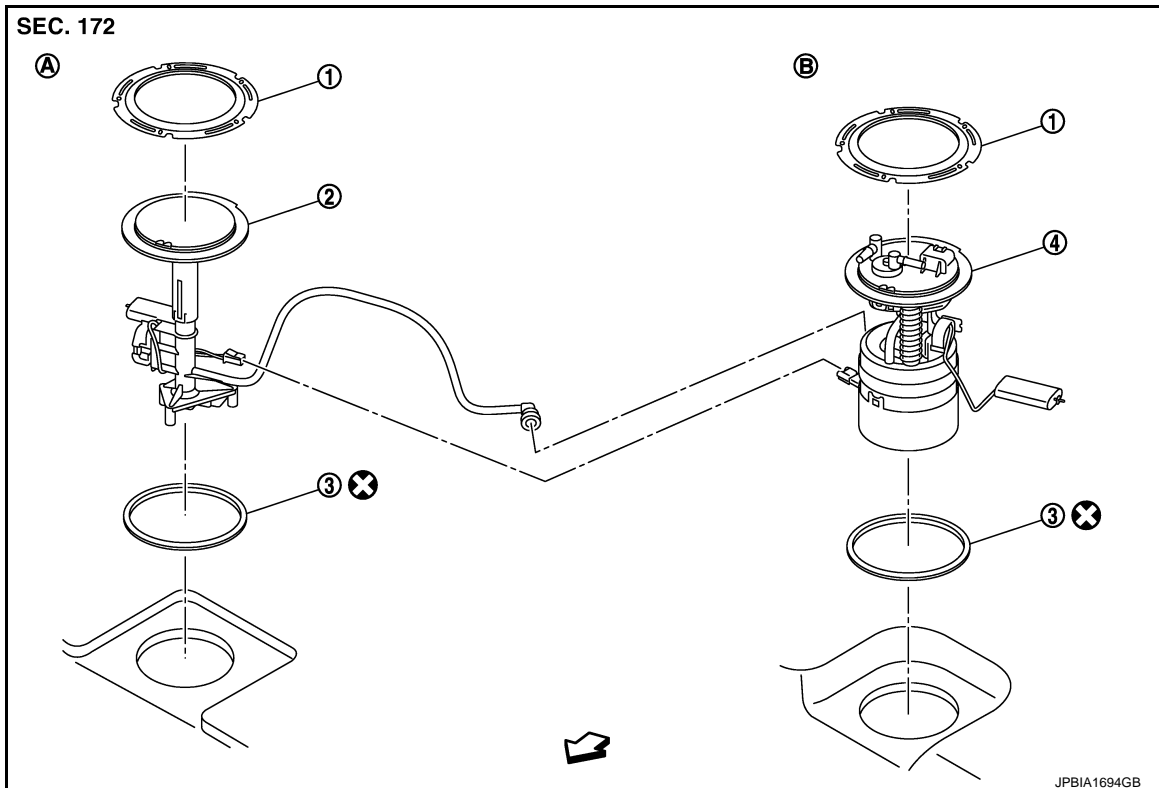

- 1. Retainer
- 2. Sub fuel level sensor unit
- 3. Seal packing
- 4. Main fuel level sensor unit, fuel filter and fuel pump assembly
- A. Right side
- B. Left side
- ↔ : Vehicle front
- ⊗ : Always replace after every disassembly.

DISASSEMBLY

C

D

E

F

G

H

I

J

K

L

M

N

O

P

FUEL LEVEL SENSOR UNIT, FUEL FILTER AND FUEL PUMP ASSEMBLY

< REMOVAL AND INSTALLATION >

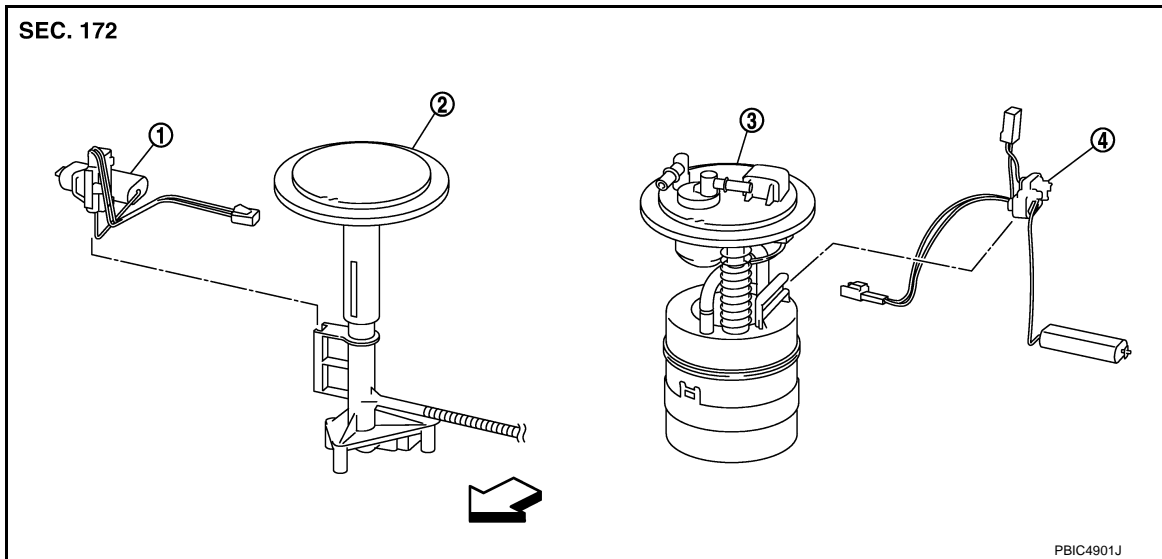

1. Sub fuel level sensor unit 2. Sub fuel level sensor unit base 3. Fuel filter and fuel pump assembly

4. Fuel level sensor unit

← : Vehicle front

Removal and Installation

INFOID:000000006937831

WARNING:

Read “General Precautions” when working on the fuel system. Refer to [FL-2, "General Precautions"](#).

REMOVAL

1. Check fuel level on a level ground. If the fuel level is 7/8 of the fuel tank (full or nearly full), draw appropriate amount of fuel from the fuel tank.

Guideline : Draw approximately 20 liters from a full-tank condition

- In the event of malfunction in fuel pump, insert a hose measuring 25 mm (0.98 in) in diameter into the filler opening to draw approximately 20 liters fuel.
2. Release the fuel pressure from the fuel lines. Refer to [EC-134, "Work Procedure"](#).
 3. Open fuel filler lid.
 4. Open filler cap and release the pressure inside fuel tank.
 5. Remove rear seat cushion and reclining device assembly. Refer to [SE-56, "Exploded View"](#).
 6. Remove inspection hole cover. Refer to [SE-56, "Exploded View"](#).
 7. Peel off floor carpet, then remove inspection hole cover units by turning clips clockwise by 90 degrees.

Left side : Main fuel level sensor unit, fuel filter and fuel pump assembly

Right side : Sub fuel level sensor unit

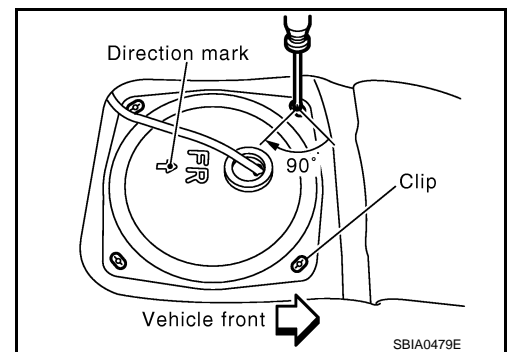

FUEL LEVEL SENSOR UNIT, FUEL FILTER AND FUEL PUMP ASSEMBLY

< REMOVAL AND INSTALLATION >

8. Disconnect harness connector, fuel feed tube and EVAP hose.

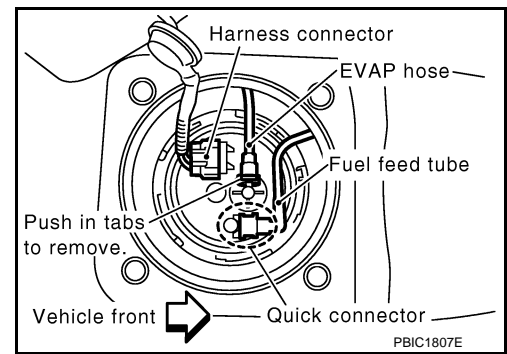

Disconnect quick connector as follows:

- Hold the sides of connector, push in tabs (B) and pull out fuel feed tube.

A : Pull

- If quick connector sticks to tube of main fuel level sensor unit, push and pull quick connector several times until they start to move. Then disconnect them by pulling.

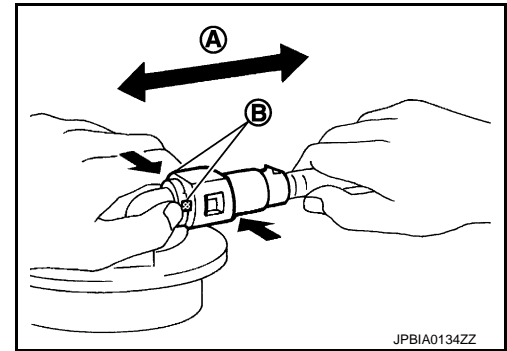

CAUTION:

- **Quick connector (1) can be disconnected when the tabs (F) are completely depressed. Never twist it more than necessary.**

B : Connection (cross-section)

D : To under floor fuel line

E : To fuel tank

G : Disconnection

- **Never use any tools to disconnected quick connector.**
- **Keep resin tube (C) away from heat. Be especially careful when welding near the resin tube.**
- **Prevent acid liquid such as battery electrolyte, etc. from getting on resin tube.**
- **Never bend or twist resin tube during installation and disconnection.**
- **Never remove the remaining retainer (2) on hard tube (or the equivalent) (A) except when resin tube or retainer is replaced.**
- **When resin tube or hard tube (or the equivalent) is replaced, also replace retainer with new one.**

Retainer color: Green

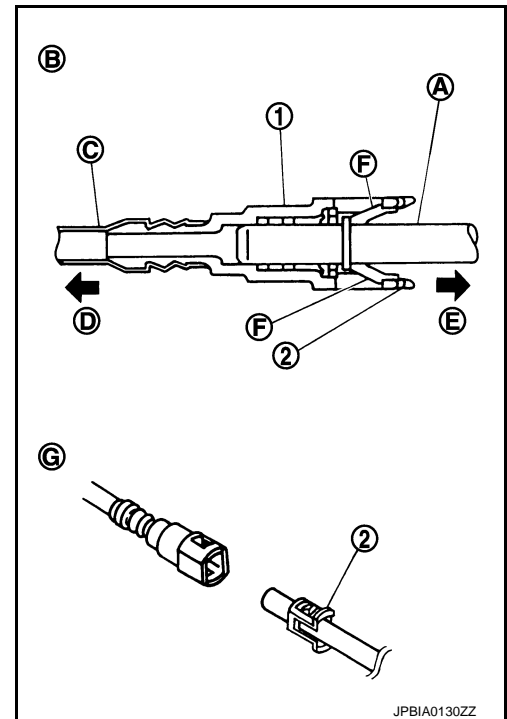

FUEL LEVEL SENSOR UNIT, FUEL FILTER AND FUEL PUMP ASSEMBLY

< REMOVAL AND INSTALLATION >

- To keep the connecting portion clean and to avoid damage and foreign materials, cover them completely with plastic bags (A) or something similar.

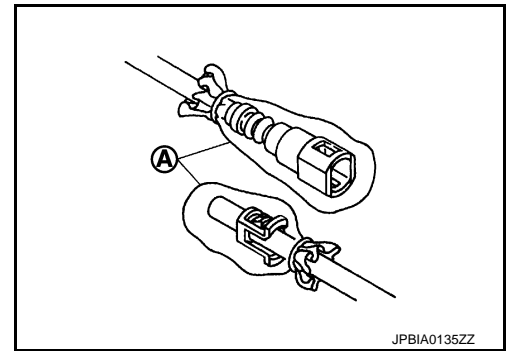

9. Remove retainer for main fuel level sensor unit, fuel filter and fuel pump assembly and sub fuel level sensor unit with fuel tank lock ring wrench (SST) by turning counterclockwise.

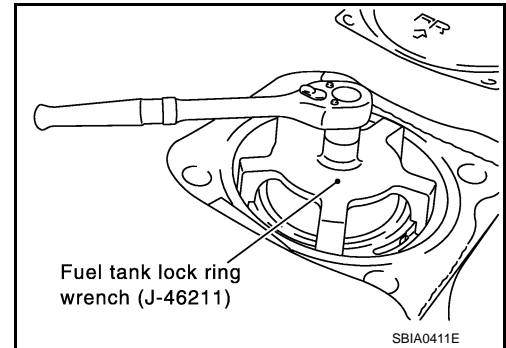

10. Remove main fuel level sensor unit, fuel filter and fuel pump assembly, and sub fuel level sensor unit.

- Raise main fuel level sensor unit, fuel filter and fuel pump assembly, and disconnect fuel hose connector (push in tabs and pull out) and sub fuel level sensor unit harness connector.
- Raise and release sub fuel level sensor unit to remove.

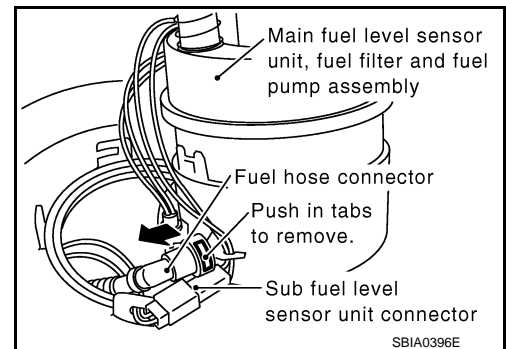

INSTALLATION

Note to the following, and install in the reverse order of removal.

Main and Sub Fuel Level Sensor Unit

1. Install new seal packing to fuel tank without any twist.
2. Connect fuel hose connector (push in until it stops) and sub fuel level sensor unit harness connector.

NOTE:

When installing fuel hose connector insert them fully until a click sound of full stopper engagement is heard.

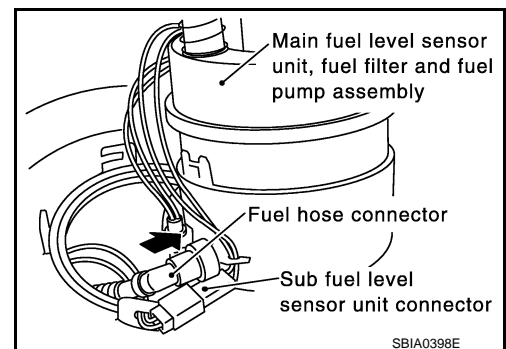

FUEL LEVEL SENSOR UNIT, FUEL FILTER AND FUEL PUMP ASSEMBLY

< REMOVAL AND INSTALLATION >

- Align the direction mark on main fuel level sensor unit, fuel filter and fuel pump assembly and sub fuel level sensor unit with that on fuel tank as shown in the figure, and install them to fuel tank.

CAUTION:

- Never allow seal packing to drop.
- Never bend float arm during installing.

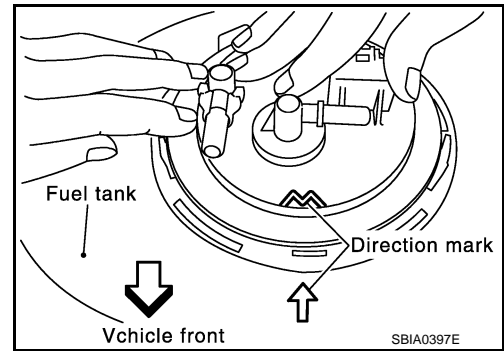

- Install retainer for main fuel level sensor unit, fuel filter and fuel pump assembly and sub fuel level sensor unit with fuel tank lock ring wrench (SST) by turning clockwise.

CAUTION:

Install retainer horizontally.

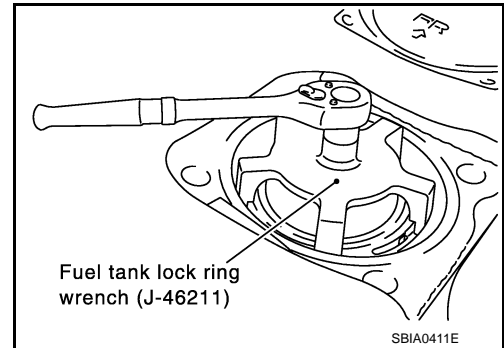

Quick Connector

Connect quick connector as follows:

- Check the connection for damage or any foreign materials.
- Align the connector with the tube, then insert the connector straight into the tube until a click sound is heard.
- After connecting, check that the connection is secure by following method.
 - Pull (A) the tube and the connector to check they are securely connected.
 - Visually confirm that the two retainer tabs are connected to the connector.

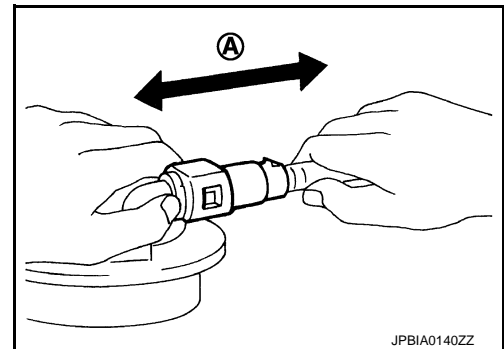

Disassembly and Assembly

INFOID:000000006937832

DISASSEMBLY

Fuel level sensor unit, fuel filter and fuel pump assembly side

- Disconnect harness connector.
- Remove fuel level sensor unit according to the following procedure.

A
FL
C
D
E
F
G
H
I
J
K
L
M
N
O
P

FUEL LEVEL SENSOR UNIT, FUEL FILTER AND FUEL PUMP ASSEMBLY

< REMOVAL AND INSTALLATION >

- a. Push the pawl of fuel level sensor unit (1) mounting area with an L-shaped iron rod or an equivalent to unlock.
CAUTION:
Never damage it.
- b. With the fuel level sensor unit unlocked, slide it in the direction shown by the arrow (←).

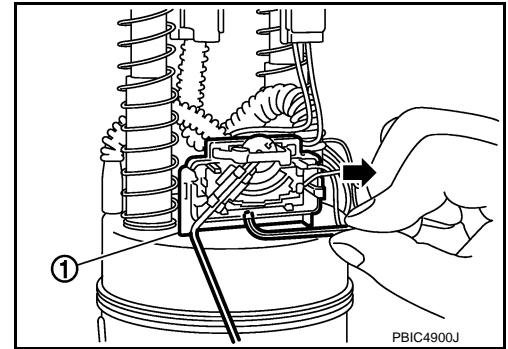

Sub fuel level sensor unit assembly side

1. Remove sub fuel level sensor unit according to the following procedure.
 - a. Push the pawl of sub fuel level sensor unit (1) mounting area with an L-shaped iron rod or an equivalent to unlock.
CAUTION:
Never damage it.
 - b. With the sub fuel level sensor unit unlocked, slide it in the direction shown by the arrow (←).

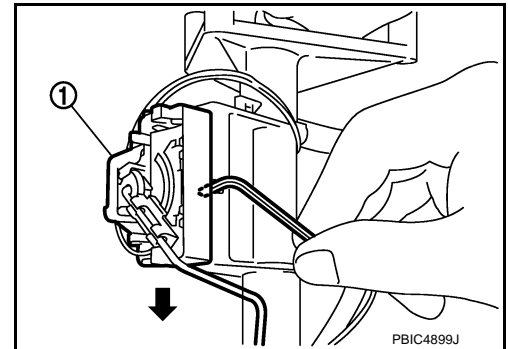

ASSEMBLY

Install fuel level sensor unit and sub fuel level sensor unit according to the following procedure.

- Insert fuel level sensor unit and sub fuel level sensor unit all the way to the end until a “click” touch and sound can be recognized.
- Pull fuel level sensor unit and sub fuel level sensor unit in the removal direction to ensure that they do not become detached.

Inspection

INFOID:000000006937833

INSPECTION AFTER INSTALLATION

Use the following procedure to check for fuel leakage.

1. Turn ignition switch “ON” (with engine stopped), then check connections for leakage by applying fuel pressure to fuel piping.
2. Start engine and let it idle and check there are no fuel leakage at the fuel system connections.

FUEL TANK

< REMOVAL AND INSTALLATION >

FUEL TANK

Exploded View

INFOID:000000006937834

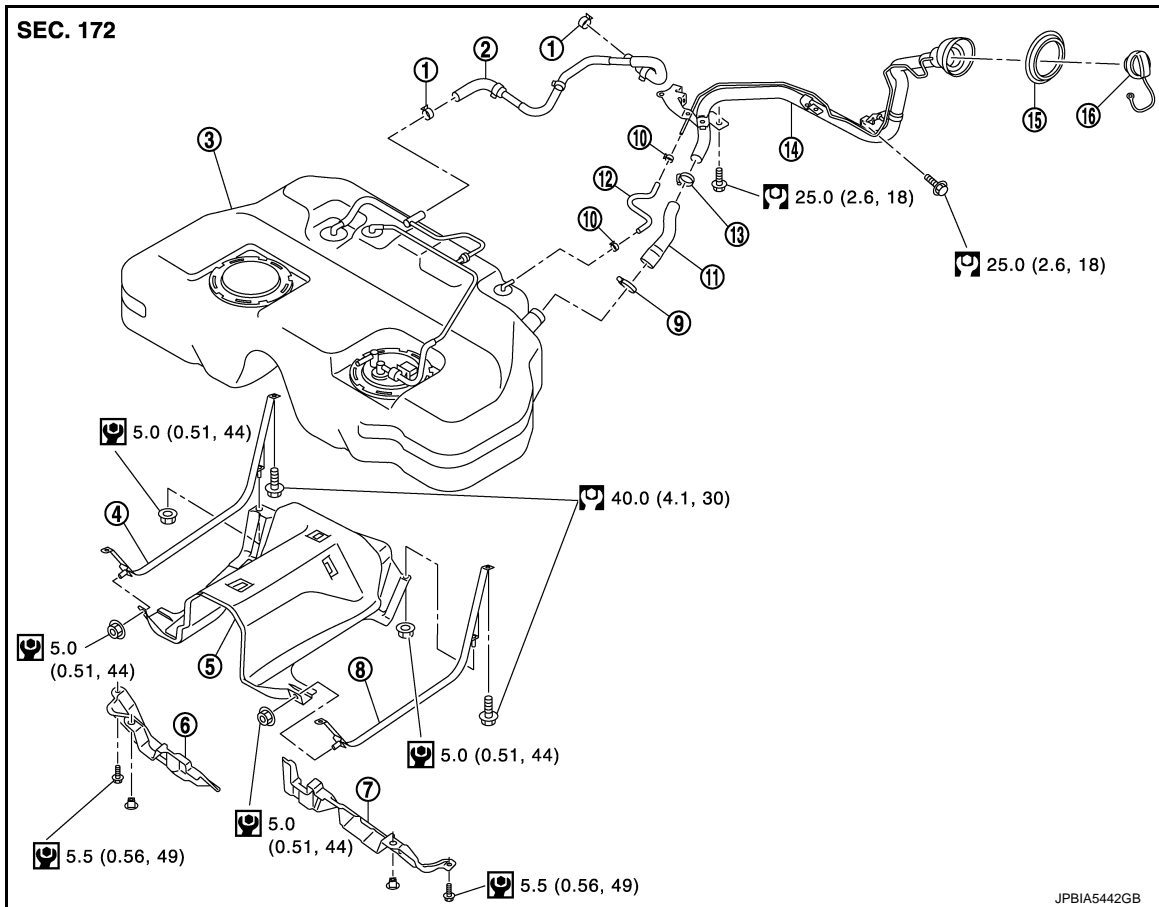

- | | | |
|---------------------------------|---------------------------------|-------------------------------|
| 1. Clamp | 2. EVAP/Vent line hose | 3. Fuel tank |
| 4. Fuel tank mounting band (RH) | 5. Fuel tank protector | 6. Fuel tank protector (RH) |
| 7. Fuel tank protector (LH) | 8. Fuel tank mounting band (LH) | 9. Clamp |
| 10. Clamp | 11. Fuel filler hose | 12. EVAP (Recirculation) hose |
| 13. Clamp | 14. Fuel filler tube | 15. Grommet |
| 16. Fuel filler cap | | |

: N·m (kg·m, ft·lb)

: N·m (kg·m, in·lb)

Removal and Installation

INFOID:000000006937835

WARNING:

Be sure to read "General Precautions" when working on the fuel system. Refer to [FL-2, "General Precautions"](#).

REMOVAL

- Drain fuel from fuel tank if necessary. Refer to [FL-6, "Removal and Installation"](#).
 - Perform work on level place.
1. Perform steps 2 to 7 of "REMOVAL" in "FUEL LEVEL SENSOR UNIT, FUEL FILTER AND FUEL PUMP ASSEMBLY" on main and sub fuel level sensor units. Refer to [FL-6, "Removal and Installation"](#).
 2. Remove center muffler. Refer to [EX-5, "Exploded View"](#).
 3. Remove propeller shaft. Refer to [DLN-83, "Exploded View"](#).

FUEL TANK

< REMOVAL AND INSTALLATION >

4. Remove parking rear brake cables. Refer to [PB-6, "Exploded View"](#).
5. Remove rear suspension member assembly. Refer to [RSU-18, "Exploded View"](#).

NOTE:

For this service, drive shaft, final drive, and rear suspension member are required not to be separate one another during removal.

6. Remove fuel tank protectors.
7. Disconnect fuel filler hose (1), EVAP/Vent line hose (3), and EVAP (Recirculation) hose (2) from the side other than the fuel tank side.

⇐ : Vehicle front

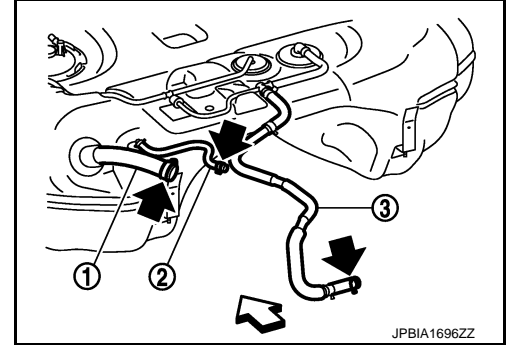

8. Support the lower part of fuel tank (1) with transmission jack (A).

CAUTION:

Support the position that fuel tank mounting bands never engage.

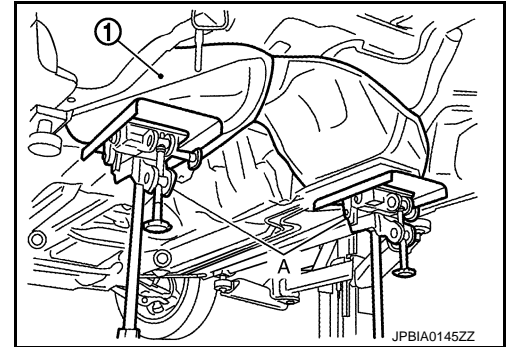

9. Remove fuel tank mounting bands.
10. Supporting with hands, descend transmission jack carefully, and remove fuel tank.

CAUTION:

- Check that all connection points have been disconnected.
- Confirm there is no interference with vehicle.

11. Remove fuel filler tube if necessary.

INSTALLATION

Note the following, and install in the reverse order of removal.

- Surely clamp fuel hoses and insert hose to the length below.

Fuel filler hose : 35 mm (1.38 in)

The other hoses : 25 mm (0.98 in)

- Be sure hose clamp is not placed on swelled area of fuel tube.
- Tighten the clamp hand with the top mark (A) until the mark is on the bolt head flange.

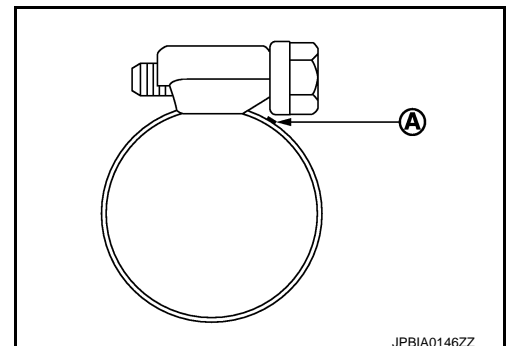

- To connect quick connector, refer to [FL-6, "Removal and Installation"](#).

FUEL TANK

< REMOVAL AND INSTALLATION >

Inspection

INFOID:000000006937836

A

INSPECTION AFTER INSTALLATION

Use the following procedure to check for fuel leakage.

1. Turn ignition switch "ON" (with engine stopped), and check connections for leakage by applying fuel pressure to fuel piping.
 2. Start engine and rev it up and check there are no fuel leakage at the fuel system tube and hose connections.
- After removing/installing rear suspension assembly, check to adjust wheel alignment and then, adjust neutral position of steering angle sensor. Refer to [RSU-6. "Inspection"](#) and [BRC-35. "Work Procedure"](#).

FL

C

D

E

F

G

H

I

J

K

L

M

N

O

P

EVAP CANISTER

< REMOVAL AND INSTALLATION >

EVAP CANISTER

Hydraulic Layout

INFOID:000000007039732

EVAPORATIVE EMISSION LINE DRAWING

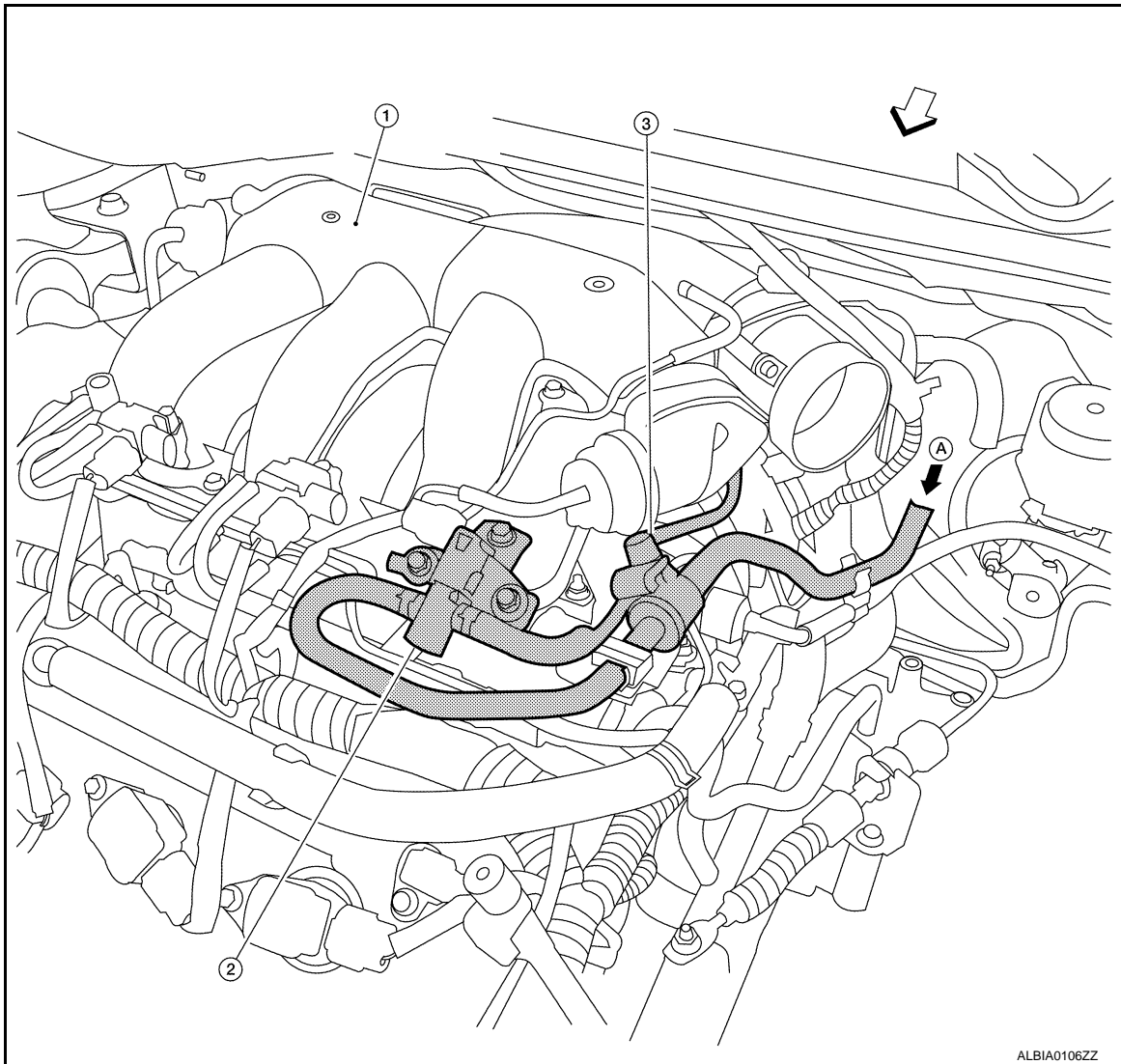

ALBIA0106ZZ

1. Intake manifold collector 2. EVAP canister purge volume control solenoid valve 3. EVAP service port

A. From EVAP canister

↙ : Vehicle front

EVAP CANISTER

< REMOVAL AND INSTALLATION >

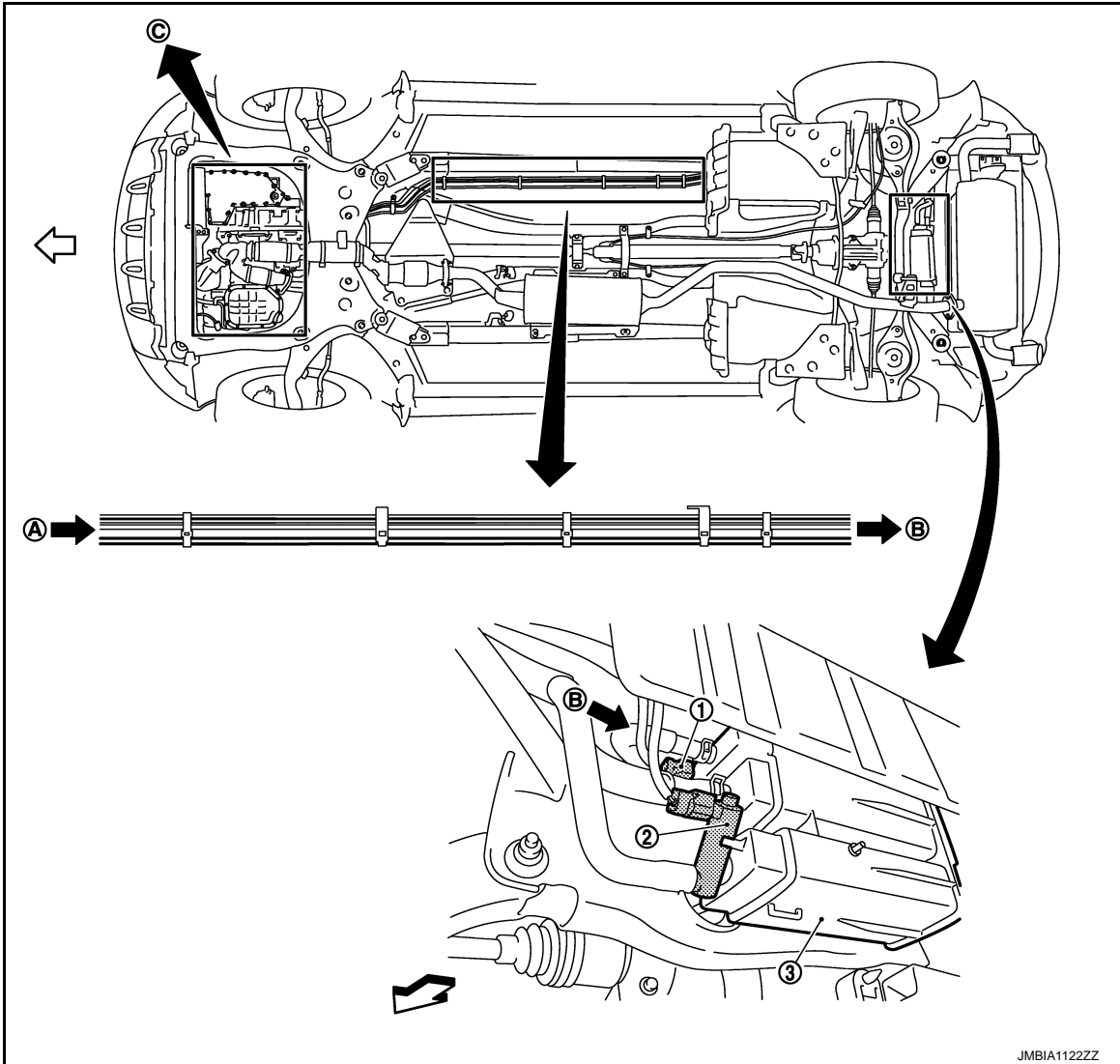

- | | | |
|--|-------------------------------------|-----------------------------|
| 1. EVAP control system pressure sensor | 2. EVAP canister vent control valve | 3. EVAP canister |
| A. To previous figure | B. To/From B in this figure | C. Refer to previous figure |
- ↶ : Vehicle front

NOTE:

Do not use soapy water or any type of solvent while installing vacuum hose or purge hoses.

A

FL

C

D

E

F

G

H

I

J

K

L

M

N

O

P

EVAP CANISTER

< REMOVAL AND INSTALLATION >

Exploded View

INFOID:000000006937837

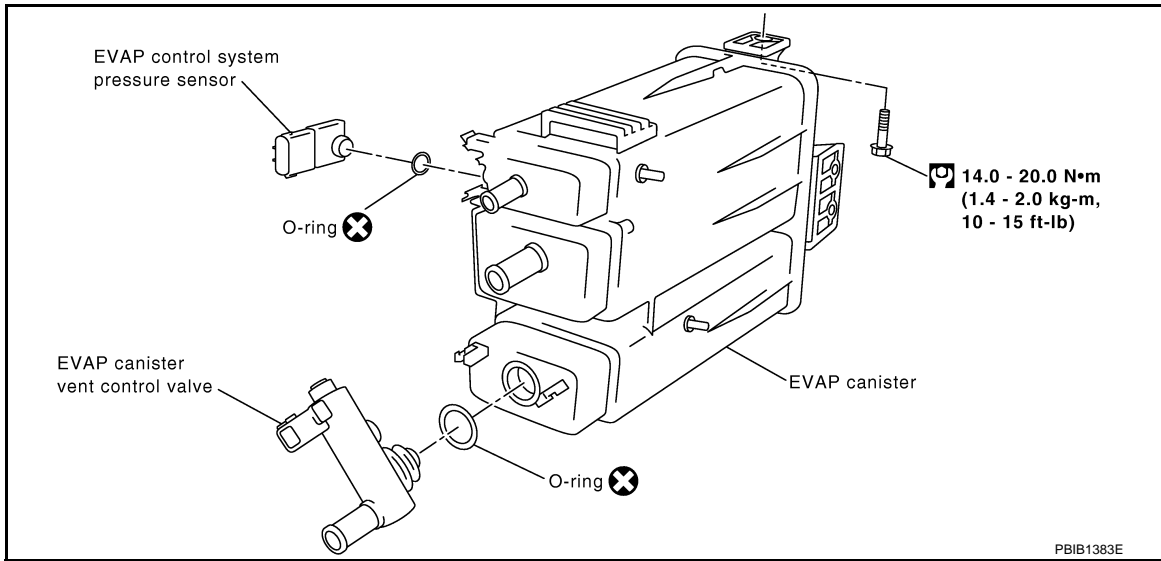

Removal and Installation

INFOID:000000006937838

REMOVAL

1. Lift up the vehicle.
2. Remove EVAP canister fixing bolt.
3. Remove EVAP canister.

NOTE:

The EVAP canister vent control valve and EVAP canister system pressure sensor can be removed without removing the EVAP canister.

INSTALLATION

Install in the reverse order of removal.

NOTE:

Tighten EVAP canister fixing bolt to the specified torque.

DISASSEMBLY

1. Turn EVAP canister vent control valve counterclockwise.
2. Remove the EVAP canister vent control valve.

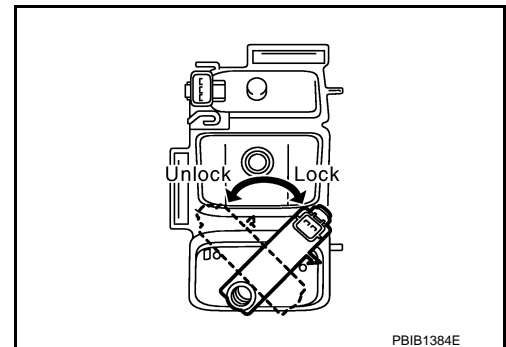

ASSEMBLY

CAUTION:

Always replace O-ring with a new one.

Assemble in the reverse order of disassembly.

EVAP CANISTER

< REMOVAL AND INSTALLATION >

Inspection

INFOID:000000006937839

Check EVAP canister as per the following:

1. Block port (B).
2. Blow air into port (A) and check that it flows freely out of port (C).
3. Release blocked port (B).
4. Apply vacuum pressure to port (B) and check that vacuum pressure exists at the ports (A) and (C).
5. Block port (A) and (B).
6. Apply pressure to port (C) and check that there is no leakage.

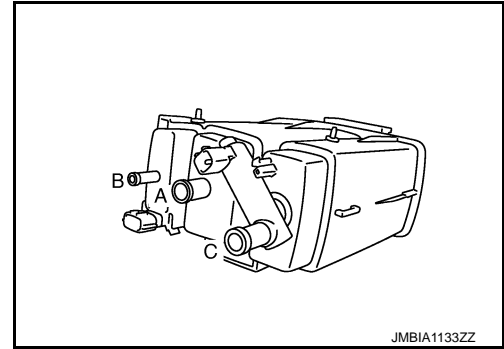

A

FL

C

D

E

F

G

H

I

J

K

L

M

N

O

P

SERVICE DATA AND SPECIFICATIONS (SDS)

< SERVICE DATA AND SPECIFICATIONS (SDS)

SERVICE DATA AND SPECIFICATIONS (SDS)

SERVICE DATA AND SPECIFICATIONS (SDS)

Fuel Tank

INFOID:000000006937840

Standard and Limit

Fuel tank capacity	Approx. 82 ℓ (21-5/8 US gal, 18 Imp gal)
Fuel recommendation	Refer to GI-28