

SECTION **PWO**  
POWER OUTLET

A  
B  
C  
D  
E  
F  
G  
H  
I  
J  
K  
L  
N  
O  
P

CONTENTS

<b>PRECAUTION</b> .....	2	<b>REMOVAL AND INSTALLATION</b> .....	6
<b>PRECAUTIONS</b> .....	2	<b>POWER SOCKET</b> .....	6
Precaution for Supplemental Restraint System (SRS) "AIR BAG" and "SEAT BELT PRE-TENSIONER" .....	2	<b>FRONT POWER SOCKET</b> .....	6
Service Procedure Precautions for Models with a Pop-up Roll Bar .....	2	FRONT POWER SOCKET : Exploded View .....	6
Precaution for Battery Service .....	2	FRONT POWER SOCKET : Removal and Installation .....	6
<b>WIRING DIAGRAM</b> .....	3	<b>CONSOLE POWER SOCKET</b> .....	6
<b>POWER SOCKET</b> .....	3	CONSOLE POWER SOCKET : Exploded View .....	6
Wiring Diagram .....	3	CONSOLE POWER SOCKET : Removal and Installation .....	6

PWO

# PRECAUTIONS

< PRECAUTION >

## PRECAUTION

### PRECAUTIONS

#### Precaution for Supplemental Restraint System (SRS) "AIR BAG" and "SEAT BELT PRE-TENSIONER"

INFOID:000000007262402

The Supplemental Restraint System such as "AIR BAG" and "SEAT BELT PRE-TENSIONER", used along with a front seat belt, helps to reduce the risk or severity of injury to the driver and front passenger for certain types of collision. This system includes seat belt switch inputs and dual stage front air bag modules. The SRS system uses the seat belt switches to determine the front air bag deployment, and may only deploy one front air bag, depending on the severity of a collision and whether the front occupants are belted or unbelted. Information necessary to service the system safely is included in the "SRS AIR BAG" and "SEAT BELT" of this Service Manual.

#### **WARNING:**

Always observe the following items for preventing accidental activation.

- To avoid rendering the SRS inoperative, which could increase the risk of personal injury or death in the event of a collision that would result in air bag inflation, all maintenance must be performed by an authorized NISSAN/INFINITI dealer.
- Improper maintenance, including incorrect removal and installation of the SRS, can lead to personal injury caused by unintentional activation of the system. For removal of Spiral Cable and Air Bag Module, see "SRS AIR BAG".
- Never use electrical test equipment on any circuit related to the SRS unless instructed to in this Service Manual. SRS wiring harnesses can be identified by yellow and/or orange harnesses or harness connectors.

#### PRECAUTIONS WHEN USING POWER TOOLS (AIR OR ELECTRIC) AND HAMMERS

#### **WARNING:**

Always observe the following items for preventing accidental activation.

- When working near the Air Bag Diagnosis Sensor Unit or other Air Bag System sensors with the ignition ON or engine running, never use air or electric power tools or strike near the sensor(s) with a hammer. Heavy vibration could activate the sensor(s) and deploy the air bag(s), possibly causing serious injury.
- When using air or electric power tools or hammers, always switch the ignition OFF, disconnect the battery, and wait at least 3 minutes before performing any service.

#### Service Procedure Precautions for Models with a Pop-up Roll Bar

INFOID:000000007262408

#### **WARNING:**

Always observe the following items for preventing accidental activation.

- Risk of passenger injury or death may increase if the pop-up roll bar does not deploy during a roll over collision. In order to reduce the chance of an incident where the pop-up roll bar is inoperative, all maintenance must be performed by a NISSAN or INFINITI dealer.
- Before removing and installing the pop-up roll bar component parts and harness, always turn the ignition switch OFF, disconnect the battery negative terminal, and wait for 3 minutes or more. (The purpose of this operation is to discharge electricity that is accumulated in the auxiliary power supply circuit in the air bag diagnosis sensor unit.)
- When repairing, removing, and installing a pop-up roll bar, always refer to SRS AIR BAG and SRS AIR BAG CONTROL warnings in the Service Manual.

#### Precaution for Battery Service

INFOID:000000007262407

Before disconnecting the battery, lower both the driver and passenger windows. This will prevent any interference between the window edge and the vehicle when the door is opened/closed. During normal operation, the window slightly raises and lowers automatically to prevent any window to vehicle interference. The automatic window function will not work with the battery disconnected.



# POWER SOCKET

< WIRING DIAGRAM >

## POWER SOCKET

Connector No.	E105
Connector Name	WIRE TO WIRE
Connector Type	TH70MW-CS10-M3

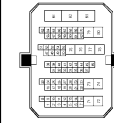

Terminal No.	Color of Wire	Signal Name [Specification]
3	Y	-
5	LG	-
8	G	-
11	P	-
12	L	-
13	Y	-
14	O	-
15	BR	-
19	L	-
20	Y	-
21	BR	-
22	P	-
24	L	-
25	O	-
28	SB	-
29	W	-
30	Y	-
49	SB	-
50	GR	-
51	LG	-
52	V	-
53	GR	-
54	BR	-
55	Y	-
56	O	-
60	V	-
61	BR	-
62	O	-
63	W	-
64	SHIELD	-
66	W	-
67	BR	-
68	Y	-
69	SB	-
70	GR	-
71	SB	-
72	Y	-
75	BR	-

76	GR	-
77	O	-
78	Y	-
79	Y	-
80	Y	-
81	Y	-
82	LG	-
83	GR	-

Connector No.	M1
Connector Name	FUSE BLOCK (J/B)
Connector Type	NS30FW-M2

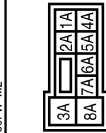

Terminal No.	Color of Wire	Signal Name [Specification]
1A	Y	-
2A	G	-
3A	Y	-
4A	GR	-
5A	R	-
6A	W	-
7A	LG	-
8A	Y	-

Connector No.	M11
Connector Name	WIRE TO WIRE
Connector Type	TH70PW-CS10-M3

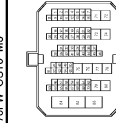

Terminal No.	Color of Wire	Signal Name [Specification]
3	P	-
5	O	-
8	R	-
11	P	-

Connector No.	M81
Connector Name	FRONT POWER SOCKET
Connector Type	PO2FB-Z

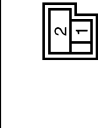

Terminal No.	Color of Wire	Signal Name [Specification]
1	W	-
2	B	-

Connector No.	M82
Connector Name	POWER SOCKET RELAY
Connector Type	MS20FL-M2-LC

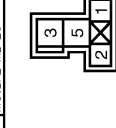

Terminal No.	Color of Wire	Signal Name [Specification]
1	B	-
2	R	-
3	G	-
5	G	-

12	L	-
13	V	-
14	Y	-
15	R	-
18	L	-
20	Y	-
21	BR	-
22	G	-
24	Y	-
25	L	-
28	BR	-
29	L	-
30	R	-
49	W	-
50	GR	-
51	LG	-
52	Y	-
53	V	-
54	SB	-
55	P	-
56	O	-
60	V	-
61	GR	-
62	O	-
63	W	-
64	SHIELD	-
66	W	-
67	R	-
68	W	-
69	P	-
70	G	-
71	G	-
72	BR	-
75	BR	-
76	R	-
77	G	-
78	Y	-
79	G	-
80	Y	-
81	Y	-
82	W	-
83	G	-



# POWER SOCKET

< WIRING DIAGRAM >

A  
B  
C  
D  
E  
F  
G  
H  
I  
J  
K  
L  
N  
O  
P

**POWER SOCKET**

Connector No.	M83
Connector Name	CONSOLE POWER SOCKET
Connector Type	PO/PE-2

Terminal No.	Color of Wire	Signal Name [Specification]
1	G	-
2	B	-

PWO

JCMWA8046GB

# POWER SOCKET

< REMOVAL AND INSTALLATION >

## REMOVAL AND INSTALLATION

### POWER SOCKET

#### FRONT POWER SOCKET

#### FRONT POWER SOCKET : Exploded View

INFOID:000000007264020

- 1 : Inner socket
- 2 : Ring

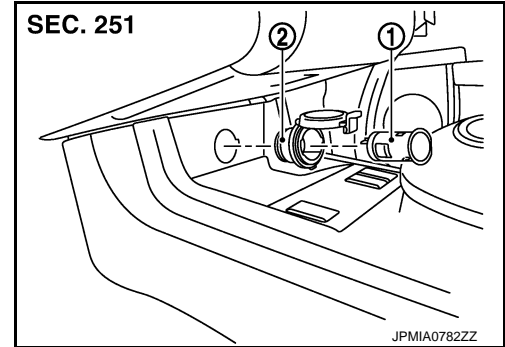

#### FRONT POWER SOCKET : Removal and Installation

INFOID:000000007264021

#### REMOVAL

1. Remove front console pocket. Refer to [JP-20. "Exploded View"](#).
2. Disconnect power socket connector (A).

D : Cut out

3. Pull out inner socket (1) by pushing the ring pawl (B) from the inner socket hole (square) (C).
4. Remove ring (2) from front console pocket while pressing pawls.

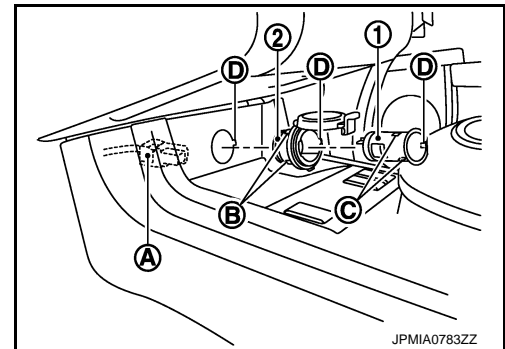

#### INSTALLATION

Install in the reverse order of removal.

#### NOTE:

Align the cut outs of inner socket, ring, and front console pocket.

### CONSOLE POWER SOCKET

#### CONSOLE POWER SOCKET : Exploded View

INFOID:000000007264016

- 1 : Inner socket
- 2 : Ring

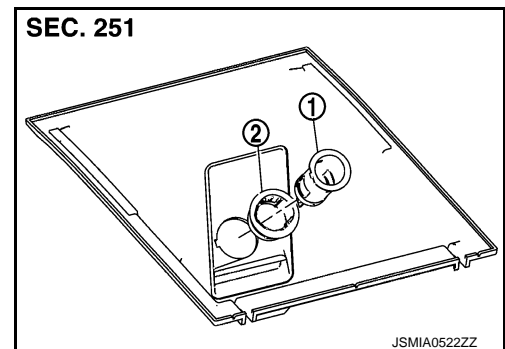

#### CONSOLE POWER SOCKET : Removal and Installation

INFOID:000000007264017

#### REMOVAL

# POWER SOCKET

## < REMOVAL AND INSTALLATION >

1. Remove console finisher assembly. Refer to [JP-20. "Exploded View"](#).
2. Disconnect power socket connector (A).

B : Hole for power socket  
(Console box)

E : Cut out

3. Pull out inner socket (1) by pushing the ring pawl (C) from the inner socket hole (square) (D).
4. Remove ring (2) from console box while pressing pawls.

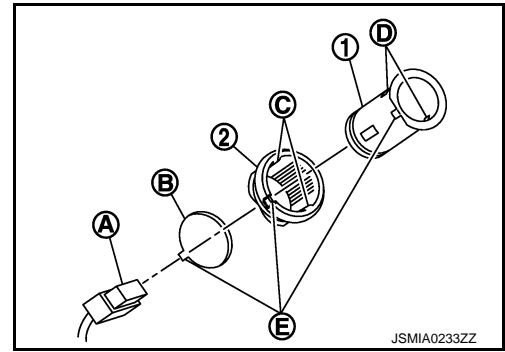

## INSTALLATION

Install in the reverse order of removal.

### NOTE:

Align the cut outs of inner socket, ring, and console box.

A  
B  
C  
D  
E  
F  
G  
H  
I  
J  
K  
L  
N  
O  
P

PWO