

WW
SECTION
WIPER & WASHER

A
B
C
D
E
F
G
H
I
J
K
L
M
N
O
P

CONTENTS

| | |
|---|---|
| <p>PRECAUTION 3</p> <p>PRECAUTIONS 3</p> <p style="padding-left: 20px;">Precaution for Supplemental Restraint System (SRS) "AIR BAG" and "SEAT BELT PRE-TENSIONER"3</p> <p style="padding-left: 20px;">Service Procedure Precautions for Models with a Pop-up Roll Bar3</p> <p style="padding-left: 20px;">Precaution for Battery Service3</p> <p style="padding-left: 20px;">Precaution for Procedure without Cowl Top Cover.....4</p> <p>SYSTEM DESCRIPTION 5</p> <p>COMPONENT PARTS 5</p> <p style="padding-left: 20px;">Component Parts Location5</p> <p style="padding-left: 20px;">Component Description6</p> <p style="padding-left: 20px;">Washer Switch6</p> <p>SYSTEM 7</p> <p>FRONT WIPER AND WASHER SYSTEM7</p> <p style="padding-left: 20px;">FRONT WIPER AND WASHER SYSTEM : System Diagram7</p> <p style="padding-left: 20px;">FRONT WIPER AND WASHER SYSTEM : System Description7</p> <p style="padding-left: 20px;">FRONT WIPER AND WASHER SYSTEM : Fail-Safe9</p> <p>DIAGNOSIS SYSTEM (BCM)10</p> <p>COMMON ITEM10</p> <p style="padding-left: 20px;">COMMON ITEM : CONSULT Function (BCM - COMMON ITEM) 10</p> <p>WIPER11</p> <p style="padding-left: 20px;">WIPER : CONSULT Function - WIPER 11</p> <p>DIAGNOSIS SYSTEM (IPDM E/R)13</p> <p style="padding-left: 20px;">Diagnosis Description13</p> <p style="padding-left: 20px;">CONSULT Function (IPDM E/R) 15</p> <p>ECU DIAGNOSIS INFORMATION18</p> | <p>BCM, IPDM E/R18</p> <p style="padding-left: 20px;">List of ECU Reference18</p> <p>WIRING DIAGRAM19</p> <p>WIPER AND WASHER SYSTEM19</p> <p style="padding-left: 20px;">Wiring Diagram19</p> <p>BASIC INSPECTION20</p> <p>DIAGNOSIS AND REPAIR WORK FLOW20</p> <p style="padding-left: 20px;">Work Flow20</p> <p>DTC/CIRCUIT DIAGNOSIS23</p> <p>FRONT WIPER MOTOR LO CIRCUIT23</p> <p style="padding-left: 20px;">Component Function Check23</p> <p style="padding-left: 20px;">Diagnosis Procedure23</p> <p>FRONT WIPER MOTOR HI CIRCUIT24</p> <p style="padding-left: 20px;">Component Function Check24</p> <p style="padding-left: 20px;">Diagnosis Procedure24</p> <p>FRONT WIPER STOP POSITION SIGNAL CIRCUIT25</p> <p style="padding-left: 20px;">Component Function Check25</p> <p style="padding-left: 20px;">Diagnosis Procedure25</p> <p>FRONT WIPER MOTOR GROUND CIRCUIT ...26</p> <p style="padding-left: 20px;">Diagnosis Procedure26</p> <p>WASHER SWITCH27</p> <p style="padding-left: 20px;">Description27</p> <p style="padding-left: 20px;">Component Inspection27</p> <p>SYMPTOM DIAGNOSIS28</p> <p>WIPER AND WASHER SYSTEM SYMPTOMS28</p> <p style="padding-left: 20px;">Symptom Table28</p> <p>NORMAL OPERATING CONDITION30</p> <p style="padding-left: 20px;">Description30</p> |
|---|---|



| | | | |
|--|-----------|---|-----------|
| FRONT WIPER DOES NOT OPERATE | 31 | WASHER NOZZLE : Inspection and Adjustment ... | 37 |
| Description | 31 | WASHER TUBE | 38 |
| Diagnosis Procedure | 31 | WASHER TUBE : Removal and Installation | 38 |
| REMOVAL AND INSTALLATION | 33 | FRONT WIPER ARM | 39 |
| WASHER TANK | 33 | Exploded View | 39 |
| Exploded View | 33 | Removal and Installation | 39 |
| Removal and Installation | 33 | Adjustment | 40 |
| WASHER PUMP | 34 | WIPER BLADE | 41 |
| Exploded View | 34 | Exploded View | 41 |
| Removal and Installation | 34 | Removal and Installation | 41 |
| WASHER LEVEL SWITCH | 35 | Replacement | 41 |
| Removal and Installation | 35 | FRONT WIPER DRIVE ASSEMBLY | 43 |
| WASHER NOZZLE & TUBE | 36 | Exploded View | 43 |
| Exploded View | 36 | Removal and Installation | 43 |
| Hydraulic Layout | 36 | Disassembly and Assembly | 44 |
| WASHER NOZZLE | 36 | WIPER AND WASHER SWITCH | 45 |
| WASHER NOZZLE : Removal and Installation | 36 | Exploded View | 45 |

PRECAUTIONS

< PRECAUTION >

PRECAUTION

PRECAUTIONS

Precaution for Supplemental Restraint System (SRS) "AIR BAG" and "SEAT BELT PRE-TENSIONER"

INFOID:000000007566605

The Supplemental Restraint System such as "AIR BAG" and "SEAT BELT PRE-TENSIONER", used along with a front seat belt, helps to reduce the risk or severity of injury to the driver and front passenger for certain types of collision. This system includes seat belt switch inputs and dual stage front air bag modules. The SRS system uses the seat belt switches to determine the front air bag deployment, and may only deploy one front air bag, depending on the severity of a collision and whether the front occupants are belted or unbelted. Information necessary to service the system safely is included in the "SRS AIR BAG" and "SEAT BELT" of this Service Manual.

WARNING:

Always observe the following items for preventing accidental activation.

- To avoid rendering the SRS inoperative, which could increase the risk of personal injury or death in the event of a collision that would result in air bag inflation, all maintenance must be performed by an authorized NISSAN/INFINITI dealer.
- Improper maintenance, including incorrect removal and installation of the SRS, can lead to personal injury caused by unintentional activation of the system. For removal of Spiral Cable and Air Bag Module, see "SRS AIR BAG".
- Never use electrical test equipment on any circuit related to the SRS unless instructed to in this Service Manual. SRS wiring harnesses can be identified by yellow and/or orange harnesses or harness connectors.

PRECAUTIONS WHEN USING POWER TOOLS (AIR OR ELECTRIC) AND HAMMERS

WARNING:

Always observe the following items for preventing accidental activation.

- When working near the Air Bag Diagnosis Sensor Unit or other Air Bag System sensors with the ignition ON or engine running, never use air or electric power tools or strike near the sensor(s) with a hammer. Heavy vibration could activate the sensor(s) and deploy the air bag(s), possibly causing serious injury.
- When using air or electric power tools or hammers, always switch the ignition OFF, disconnect the battery, and wait at least 3 minutes before performing any service.

Service Procedure Precautions for Models with a Pop-up Roll Bar

INFOID:000000007566606

WARNING:

Always observe the following items for preventing accidental activation.

- Risk of passenger injury or death may increase if the pop-up roll bar does not deploy during a roll over collision. In order to reduce the chance of an incident where the pop-up roll bar is inoperative, all maintenance must be performed by a NISSAN or INFINITI dealer.
- Before removing and installing the pop-up roll bar component parts and harness, always turn the ignition switch OFF, disconnect the battery negative terminal, and wait for 3 minutes or more. (The purpose of this operation is to discharge electricity that is accumulated in the auxiliary power supply circuit in the air bag diagnosis sensor unit.)
- When repairing, removing, and installing a pop-up roll bar, always refer to SRS AIR BAG and SRS AIR BAG CONTROL warnings in the Service Manual.

Precaution for Battery Service

INFOID:000000007566607

Before disconnecting the battery, lower both the driver and passenger windows. This will prevent any interference between the window edge and the vehicle when the door is opened/closed. During normal operation, the window slightly raises and lowers automatically to prevent any window to vehicle interference. The automatic window function will not work with the battery disconnected.

A
B
C
D
E
F
G
H
I
J
K
L
M
N
O
P

WW

PRECAUTIONS

< PRECAUTION >

Precaution for Procedure without Cowl Top Cover

INFOID:000000007566608

When performing the procedure after removing cowl top cover, cover the lower end of windshield with urethane, etc to prevent damage to windshield.

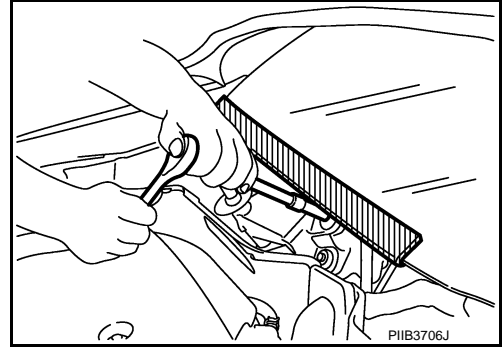

COMPONENT PARTS

< SYSTEM DESCRIPTION >

SYSTEM DESCRIPTION

COMPONENT PARTS

Component Parts Location

INFOID:000000007566609

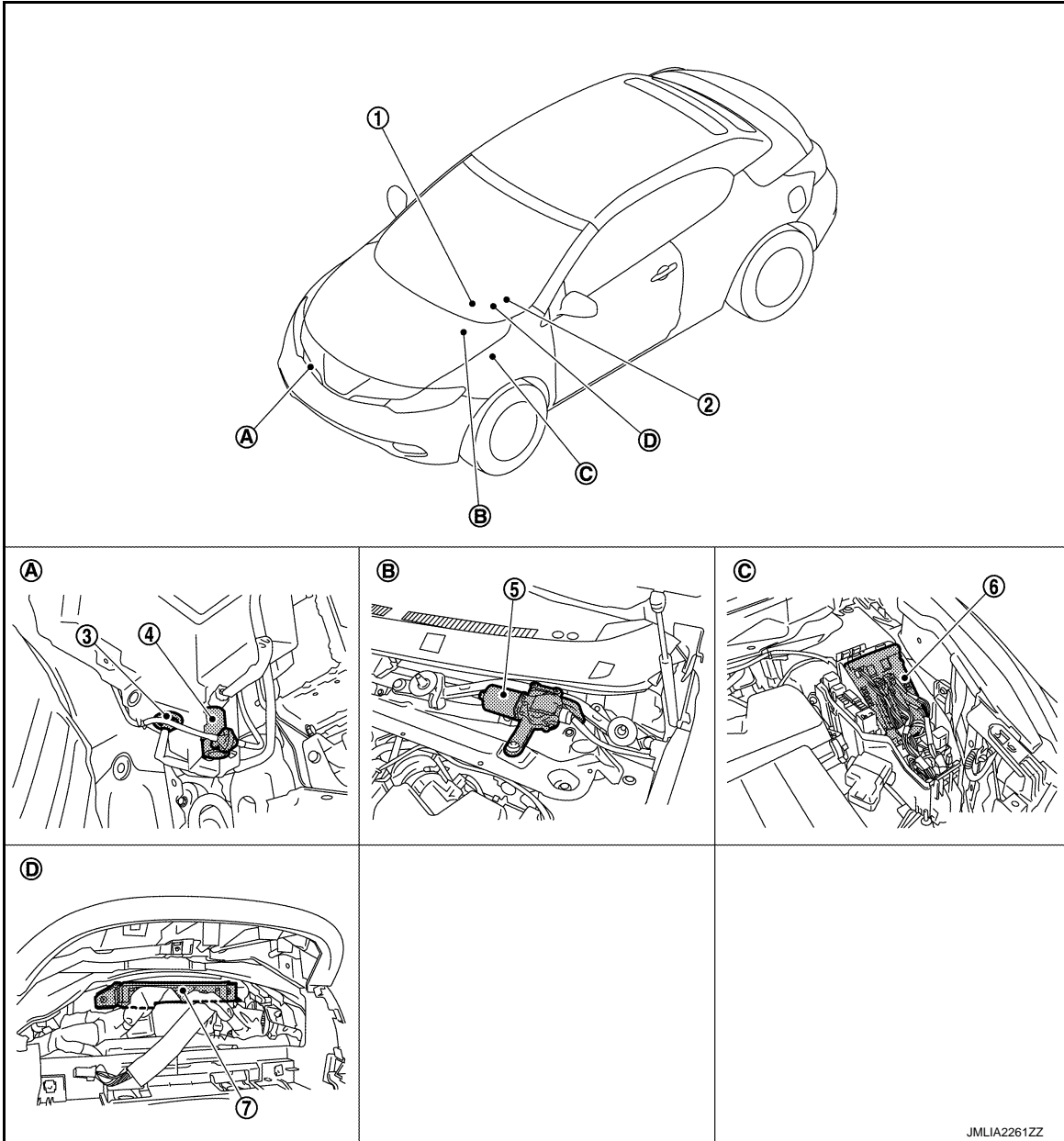

- | | | |
|-------------------------------|---------------------------------------|----------------------------|
| 1. Combination switch | 2. Combination meter | 3. Washer level switch |
| 4. Washer pump | 5. Front wiper motor | 6. IPDM E/R |
| 7. BCM | | |
| A. Radiator core support (RH) | B. Cowl top, left side of engine room | C. Engine room (left side) |
| D. Behind combination meter | | |

JMLIA2261ZZ

A
B
C
D
E
F
G
H
I
J
K
L
M
N
O
P

WW

COMPONENT PARTS

< SYSTEM DESCRIPTION >

Component Description

INFOID:000000007566610

| Part | Description |
|--|--|
| IPDM E/R | <ul style="list-style-type: none"> Controls the integrated relay according to the request (via CAN communication) from BCM. Performs the auto stop control of the front wiper. |
| BCM | <ul style="list-style-type: none"> Judges the each switch status by the combination switch reading function. Requests (via CAN communication) the front wiper relay and the front wiper high relay ON to IPDM E/R. Supplies power to the wiper motor. |
| Combination switch (Wiper & washer switch) | Refer to BCS-6, "COMBINATION SWITCH READING SYSTEM : System Description" . |
| Washer switch | Refer to WW-6, "Washer Switch" . |
| Washer pump | Washer fluid is sprayed according to washer switch states. |
| Washer level switch | Refer to MWI-6, "METER SYSTEM : Component Description" . |
| Front wiper motor | <ul style="list-style-type: none"> IPDM E/R controls front wiper operation. Front wiper stop position signal is transmitted to IPDM E/R. |
| Combination meter | Transmits the vehicle speed signal to BCM via CAN communication. |

Washer Switch

INFOID:000000007566611

- Washer switch is integrated with combination switch.
- Washer pump is grounded through the combination switch with the washes switch ON.

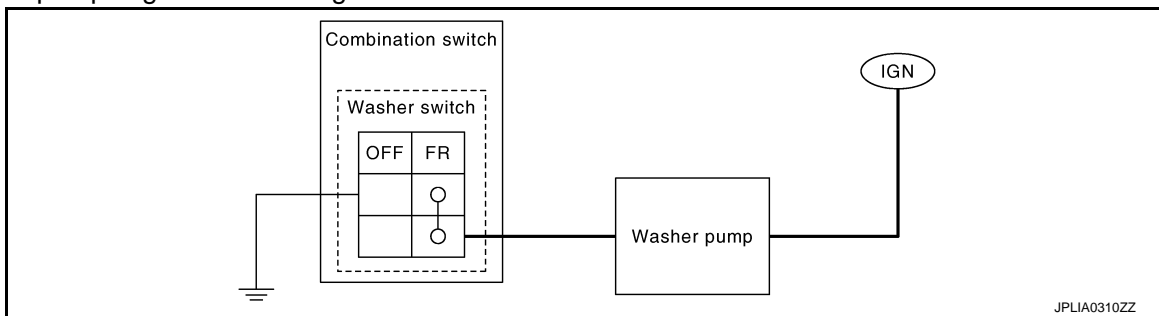

SYSTEM

< SYSTEM DESCRIPTION >

SYSTEM

FRONT WIPER AND WASHER SYSTEM

FRONT WIPER AND WASHER SYSTEM : System Diagram

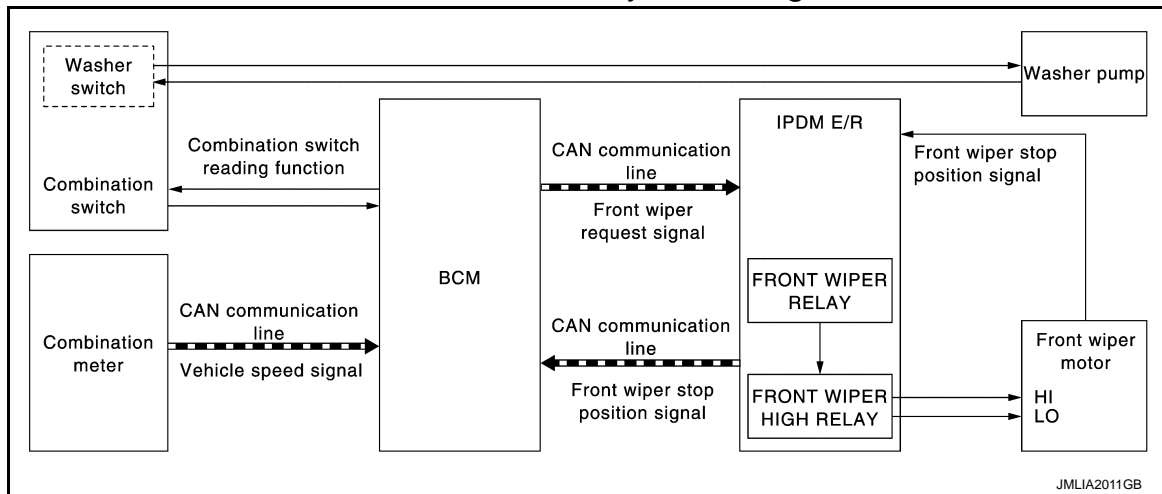

FRONT WIPER AND WASHER SYSTEM : System Description

INFOID:000000007566613

OUTLINE

The front wiper is controlled by each function of BCM and IPDM E/R.

Control by BCM

- Combination switch reading function
- Front wiper control function

Control by IPDM E/R

- Front wiper control function
- Relay control function

Combination meter indicates low washer fluid warning judged with the signal from the washer level switch. For details of low washer fluid warning, refer to [MWI-15, "INFORMATION DISPLAY : System Description"](#).

FRONT WIPER BASIC OPERATION

- BCM detects the combination switch condition by the combination switch reading function.
- BCM transmits the front wiper request signal to IPDM E/R with CAN communication depending on each operating condition of the front wiper.
- IPDM E/R turns ON/OFF the integrated front wiper relay and the front wiper high relay according to the front wiper request signal. IPDM E/R provides the power supply to operate the front wiper HI/LO operation.

FRONT WIPER LO OPERATION

- BCM transmits the front wiper request signal (LO) to IPDM E/R with CAN communication according to the front wiper LO operating condition.

Front wiper LO operating condition

- Ignition switch ON
- Front wiper switch LO or front wiper switch MIST (while pressing)
- IPDM E/R turns ON the integrated front wiper relay according to the front wiper request signal (LO).

FRONT WIPER HI OPERATION

- BCM transmits the front wiper request signal (HI) to IPDM E/R with CAN communication according to the front wiper HI operating condition.

Front wiper HI operating condition

- Ignition switch ON
- Front wiper switch HI
- IPDM E/R turns ON the integrated front wiper relay and the front wiper high relay according to the front wiper request signal (HI).

A
B
C
D
E
F
G
H
I
J
K
M
N
O
P

WW

SYSTEM

< SYSTEM DESCRIPTION >

FRONT WIPER INT OPERATION

- BCM transmits the front wiper request signal (INT) to IPDM E/R with CAN communication depending on the front wiper INT operating condition and intermittent operation delay interval according to the wiper intermittent dial position.

Front wiper INT operating condition

- Ignition switch ON
- Front wiper switch INT
- IPDM E/R turns ON the integrated front wiper relay so that the front wiper is operated only once according to the front wiper request signal (INT).
- BCM detects stop position/except stop position of the front wiper motor according to the front wiper stop position signal received from IPDM E/R with CAN communication.
- BCM transmits the front wiper request signal (INT) again after the intermittent operation delay interval.

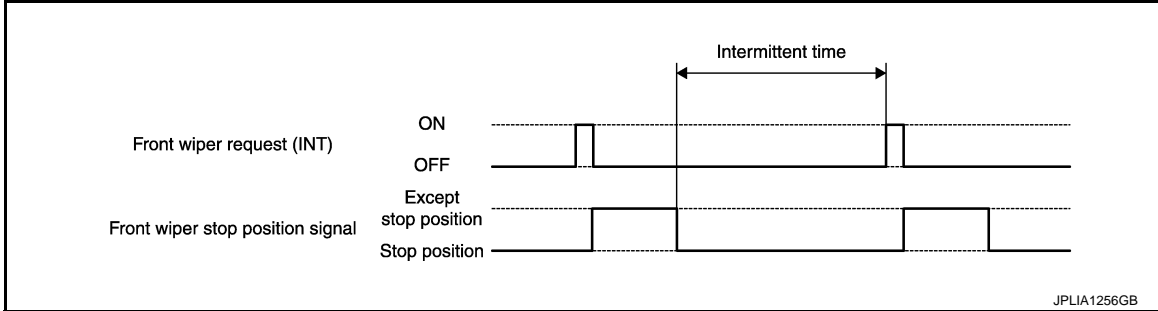

NOTE:

Factory setting of the front wiper intermittent operation is the operation without vehicle speed. Front wiper intermittent operation can be set to the operation with vehicle speed by CONSULT. Refer to [WW-11, "WIPER : CONSULT Function - WIPER"](#).

Front wiper intermittent operation with vehicle speed

- BCM calculates the intermittent operation delay interval from the following
 - Vehicle speed signal (received from the combination meter with CAN communication)
 - Wiper intermittent dial position

| Wiper intermittent dial position | Intermittent operation interval | Intermittent operation delay Interval (s) | | | |
|----------------------------------|---------------------------------|---|---------------------------------|------------------------------------|-------------------------------|
| | | Vehicle speed | | | |
| | | 0 – 5 km/h (0 – 3.1 MPH) | 5 – 35 km/h (3.1 – 21.7 MPH) | 35 – 65 km/h* (21.7 – 40.4 MPH) | 65 km/h (40.4 MPH) or more |
| 1 | Short ↑ | 0.8 | 0.6 | 0.4 | 0.24 |
| 2 | | 4 | 3 | 2 | 1.2 |
| 3 | | 10 | 7.5 | 5 | 3 |
| 4 | | 16 | 12 | 8 | 4.8 |
| 5 | | 24 | 18 | 12 | 7.2 |
| 6 | Long ↓ | 32 | 24 | 16 | 9.6 |
| 7 | | 42 | 31.5 | 21 | 12.6 |

*: When without vehicle speed setting

FRONT WIPER AUTO STOP OPERATION

- BCM stops transmitting the front wiper request signal when the front wiper switch is turned OFF.
- IPDM E/R detects the front wiper stop position signal from the front wiper motor and detects the front wiper motor position (stop position/except stop position).

SYSTEM

< SYSTEM DESCRIPTION >

- When the front wiper request signal is stopped, IPDM E/R turns ON the front wiper relay until the front wiper motor returns to the stop position.

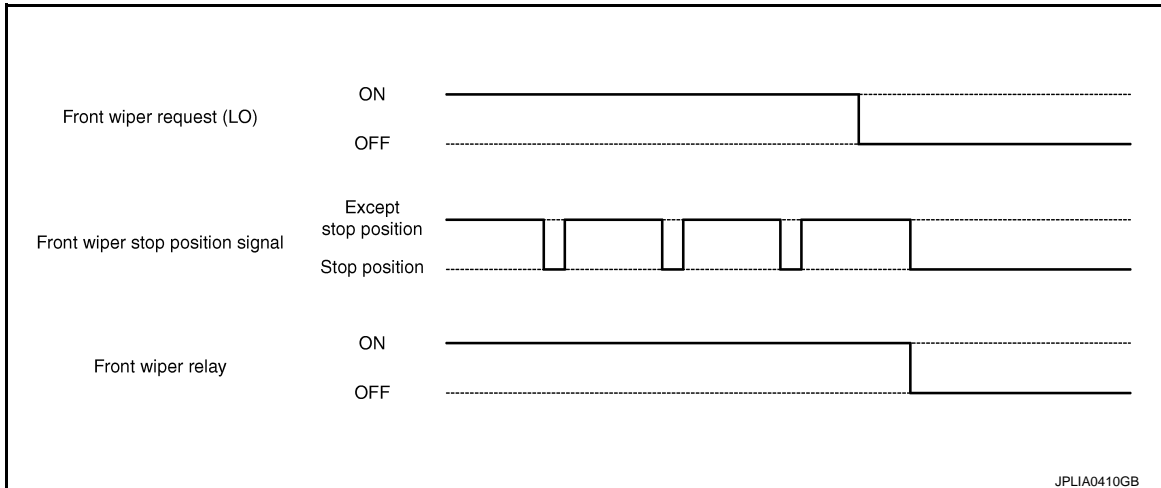

NOTE:

- BCM stops the transmitting of the front wiper request signal when the ignition switch is OFF.
- IPDM E/R turns the front wiper relay OFF when the ignition switch is OFF.

FRONT WIPER OPERATION LINKED WITH WASHER

- BCM transmits the front wiper request signal (LO) to IPDM E/R with CAN communication according to the washer linked operating condition of the front wiper.
- BCM transmits the front wiper request signal (LO) so that the front wiper operates approximately 2 times when the front washer switch OFF is detected.

Washer linked operating condition of front wiper

- Ignition switch ON
- Front washer switch ON (0.4 second or more)
- IPDM E/R turns ON the integrated front wiper relay according to the front wiper request signal (LO).
- The washer pump is grounded through the combination switch with the washer switch ON.

FRONT WIPER AND WASHER SYSTEM : Fail-Safe

INFOID:000000007566614

When CAN communication with ECM and BCM is impossible, IPDM E/R performs fail-safe control. After CAN communication recovers normally, it also returns to normal control.

If No CAN Communication Is Available With BCM

| Control part | Fail-safe operation |
|-------------------|---|
| Front wiper motor | <ul style="list-style-type: none"> The status just before activation of fail-safe control is maintained until the ignition switch is turned OFF while the front wiper is operating at LO or HI speed. The wiper is operated at LO speed until the ignition switch is turned OFF if the fail-safe control is activated while the front wiper is set in the INT mode and the front wiper motor is operating. Returns automatically wiper to stop position when ignition switch is turned ON if fail-safe control is activated while front wiper motor is operated and wiper stop in the other position than stop position. The status is held at service position if the fail-safe control is activated while the service position function is operating. |

IPDM E/R detects front wiper stop position by a front wiper stop position signal.

When a front wiper stop position signal is in the conditions listed below, IPDM E/R stops power supply to wiper after repeating a front wiper 10 seconds activation and 20 seconds stop.

| Ignition switch | Front wiper switch | Front wiper stop position signal |
|-----------------|--------------------|--|
| ON | OFF | The front wiper stop position signal (stop position) cannot be input for 10 seconds. |
| | ON | The front wiper stop position signal does not change for 10 seconds. |

NOTE:

This operation status can be confirmed on the IPDM E/R "Data Monitor" that displays "BLOCK" for the item "WIP PROT" while the wiper is stopped.

DIAGNOSIS SYSTEM (BCM)

< SYSTEM DESCRIPTION >

DIAGNOSIS SYSTEM (BCM)

COMMON ITEM

COMMON ITEM : CONSULT Function (BCM - COMMON ITEM)

INFOID:000000007805659

APPLICATION ITEM

CONSULT performs the following functions via CAN communication with BCM.

| Diagnosis mode | Function Description |
|--------------------------|---|
| Work Support | Changes the setting for each system function. |
| Self Diagnostic Result | Displays the diagnosis results judged by BCM. |
| CAN Diag Support Monitor | Monitors the reception status of CAN communication viewed from BCM. |
| Data Monitor | The BCM input/output signals are displayed. |
| Active Test | The signals used to activate each device are forcibly supplied from BCM. |
| Ecu Identification | The BCM part number is displayed. |
| Configuration | <ul style="list-style-type: none"> • Read and save the vehicle specification. • Write the vehicle specification when replacing BCM. |

SYSTEM APPLICATION

BCM can perform the following functions for each system.

NOTE:

It can perform the diagnosis modes except the following for all sub system selection items.

×: Applicable item

| System | Sub system selection item | Diagnosis mode | | |
|---|---------------------------|----------------|--------------|-------------|
| | | Work Support | Data Monitor | Active Test |
| Door lock | DOOR LOCK | × | × | × |
| Rear window defogger | REAR DEFOGGER | | × | × |
| Warning chime | BUZZER | | × | × |
| Interior room lamp timer | INT LAMP | × | × | × |
| Exterior lamp | HEAD LAMP | × | × | × |
| Wiper and washer | WIPER | × | × | × |
| Turn signal and hazard warning lamps | FLASHER | × | × | × |
| — | AIR CONDITONER* | | | |
| <ul style="list-style-type: none"> • Intelligent Key system • Engine start system | INTELLIGENT KEY | × | × | × |
| Combination switch | COMB SW | | × | |
| Body control system | BCM | × | | |
| NVIS - NATS | IMMU | | × | × |
| Interior room lamp battery saver | BATTERY SAVER | × | × | × |
| Trunk lid opener system | TRUNK | | × | × |
| Vehicle security system | THEFT ALM | × | × | × |
| RAP system | RETAINED PWR | | × | |
| Signal buffer system | SIGNAL BUFFER | | × | × |
| TPMS | AIR PRESSURE MONITOR | × | × | × |

NOTE:

*: This item is displayed, but is not used.

FREEZE FRAME DATA (FFD)

The BCM records the following vehicle condition at the time a particular DTC is detected, and displays on CONSULT.

DIAGNOSIS SYSTEM (BCM)

< SYSTEM DESCRIPTION >

| CONSULT screen item | Indication/Unit | Description | | |
|---------------------|--|--|--|----|
| Vehicle Speed | km/h | Vehicle speed of the moment a particular DTC is detected | | A |
| Odo/Trip Meter | km | Total mileage (Odometer value) of the moment a particular DTC is detected | | B |
| Vehicle Condition | SLEEP>LOCK | Power position status of the moment a particular DTC is detected | While turning BCM status from low power consumption mode to normal mode (Power supply position is "LOCK"*) | B |
| | SLEEP>OFF | | While turning BCM status from low power consumption mode to normal mode (Power supply position is "OFF".) | C |
| | LOCK>ACC | | While turning power supply position from "LOCK" to "ACC" | D |
| | ACC>ON | | While turning power supply position from "ACC" to "IGN" | D |
| | RUN>ACC | | While turning power supply position from "RUN" to "ACC" (Vehicle is stopping and selector lever is except P position.) | E |
| | CRANK>RUN | | While turning power supply position from "CRANKING" to "RUN" (From cranking up the engine to run it) | E |
| | RUN>URGENT | | While turning power supply position from "RUN" to "ACC" (Emergency stop operation) | F |
| | ACC>OFF | | While turning power supply position from "ACC" to "OFF" | F |
| | OFF>LOCK | | While turning power supply position from "OFF" to "LOCK"* | G |
| | OFF>ACC | | While turning power supply position from "OFF" to "ACC" | G |
| | ON>CRANK | | While turning power supply position from "IGN" to "CRANKING" | H |
| | OFF>SLEEP | | While turning BCM status from normal mode (Power supply position is "OFF".) to low power consumption mode | H |
| | LOCK>SLEEP | | While turning BCM status from normal mode (Power supply position is "LOCK"*) to low power consumption mode | I |
| | LOCK | | Power supply position is "LOCK"* | I |
| | OFF | | Power supply position is "OFF" (Ignition switch OFF) | J |
| | ACC | | Power supply position is "ACC" (Ignition switch ACC) | J |
| | ON | | Power supply position is "IGN" (Ignition switch ON with engine stopped) | K |
| | ENGINE RUN | | Power supply position is "RUN" (Ignition switch ON with engine running) | K |
| CRANKING | Power supply position is "CRANKING" (At engine cranking) | K | | |
| IGN Counter | 0 - 39 | The number of times that ignition switch is turned ON after DTC is detected <ul style="list-style-type: none"> • The number is 0 when a malfunction is detected now. • The number increases like 1 → 2 → 3...38 → 39 after returning to the normal condition whenever ignition switch OFF → ON. • The number is fixed to 39 until the self-diagnosis results are erased if it is over 39. | | WW |

NOTE:

*: Power supply position shifts to "LOCK" from "OFF", when ignition switch is in the OFF position, selector lever is in the P position, and any of the following conditions are met.

- Closing door
- Opening door
- Door is locked using door request switch
- Door is locked using Intelligent Key

The power supply position shifts to "ACC" when the push-button ignition switch (push switch) is pushed at "LOCK".

WIPER

WIPER : CONSULT Function - WIPER

INFOID:00000000756616

WORK SUPPORT

DIAGNOSIS SYSTEM (BCM)

< SYSTEM DESCRIPTION >

| Service item | Setting item | Description |
|---------------------|--------------|--|
| WIPER SPEED SETTING | On | With vehicle speed (Front wiper intermittent time linked with the vehicle speed and wiper intermittent dial position) |
| | Off* | Without vehicle speed (Front wiper intermittent time linked with the wiper intermittent dial position) |

*:Factory setting

DATA MONITOR

| Monitor Item [Unit] | Description |
|---------------------------|---|
| PUSH SW [Off/On] | The switch status input from push-button ignition switch |
| VEH SPEED 1 [km/h] | Displays the value of the vehicle speed signal received from combination meter via CAN communication |
| FR WIPER HI [Off/On] | Status of each switch judged by BCM using the combination switch reading function |
| FR WIPER LOW [Off/On] | |
| FR WASHER SW [Off/On] | |
| FR WIPER INT [Off/On] | |
| FR WIPER STOP [Off/On] | Displays the status of the front wiper stop position signal received from IPDM E/R via CAN communication. |
| INT VOLUME [1 – 7] | Status of each switch judged by BCM using the combination switch reading function |
| H/L WASH SW [Off/On] | NOTE: The item is indicated, but not monitored |

ACTIVE TEST

| Test item | Operation | Description |
|-----------|-----------|--|
| FR WIPER | Hi | Transmits the front wiper request signal (HI) to IPDM E/R via CAN communication to operate the front wiper HI operation. |
| | Lo | Transmits the front wiper request signal (LO) to IPDM E/R via CAN communication to operate the front wiper LO operation. |
| | INT | Transmits the front wiper request signal (INT) to IPDM E/R via CAN communication to operate the front wiper INT operation. |
| | Off | Stops transmitting the front wiper request signal to stop the front wiper operation. |

DIAGNOSIS SYSTEM (IPDM E/R)

< SYSTEM DESCRIPTION >

DIAGNOSIS SYSTEM (IPDM E/R)

Diagnosis Description

INFOID:000000007805660

AUTO ACTIVE TEST

Description

In auto active test mode, the IPDM E/R sends a drive signal to the following systems to check their operation.

- Oil pressure warning lamp
- Front wiper (LO, HI)
- Parking lamp
- License plate lamp
- Side maker lamp
- Tail lamp
- Front fog lamp
- Headlamp (LO, HI)
- A/C compressor (magnet clutch)
- Cooling fan

Operation Procedure

NOTE:

Never perform auto active test in the following conditions.

- CONSULT is connected
 - Passenger door is open
1. Close the hood and lift the wiper arms from the windshield. (Prevent windshield damage due to wiper operation)
NOTE:
When auto active test is performed with hood opened, sprinkle water on windshield beforehand.
 2. Turn the ignition switch OFF.
 3. Turn the ignition switch ON, and within 20 seconds, press the front door switch (driver side) 10 times. Then turn the ignition switch OFF.
 4. Turn the ignition switch ON within 10 seconds. After that the horn sounds once and the auto active test starts.
 5. After a series of the following operations is repeated 3 times, auto active test is completed.

NOTE:

- When auto active test has to be cancelled halfway through test, turn the ignition switch OFF.
- When auto active test is not activated, door switch may be the cause. Check door switch. Refer to [DLK-55, "Component Function Check"](#).

Inspection in Auto Active Test Mode

When auto active test mode is actuated, the following 6 steps are repeated 3 times.

| Operation sequence | Inspection location | Operation |
|--------------------|--|--|
| 1 | Oil pressure warning lamp | Blinks continuously during operation of auto active test |
| 2 | Front wiper motor | LO for 5 seconds → HI for 5 seconds |
| 3 | <ul style="list-style-type: none">• Parking lamp• License plate lamp• Side maker lamp• Tail lamp• Front fog lamp | 10 seconds |
| 4 | Headlamp | LO ⇔ HI 5 times |
| 5 | A/C compressor (magnet clutch) | ON ⇔ OFF 5 times |
| 6 | Cooling fan | LO for 5 seconds → MID for 3 seconds → HI for 2 seconds |

DIAGNOSIS SYSTEM (IPDM E/R)

< SYSTEM DESCRIPTION >

Concept of auto active test

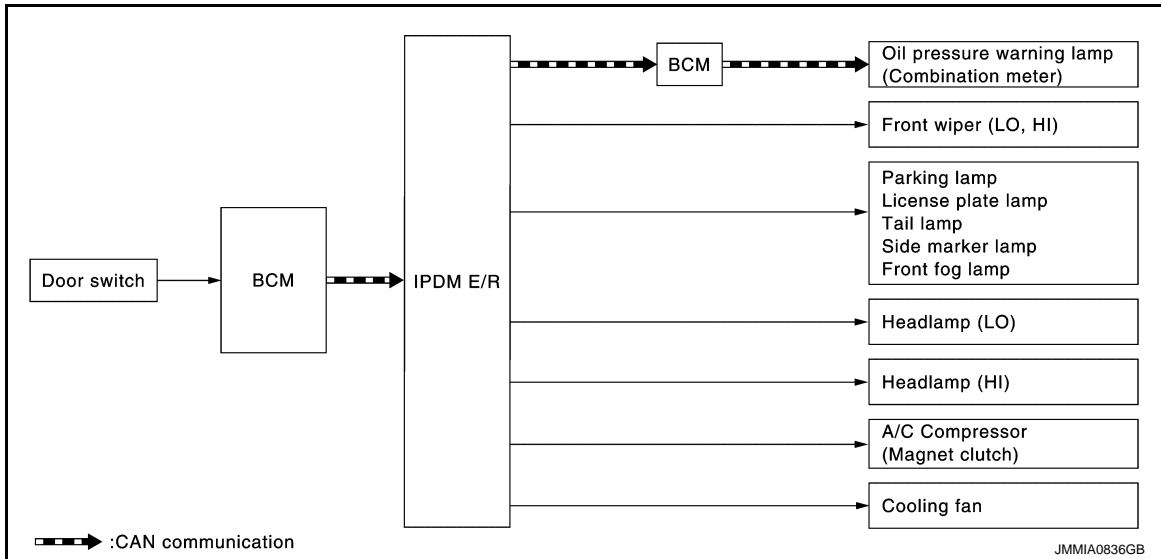

- IPDM E/R starts the auto active test with the door switch signals transmitted by BCM via CAN communication. Therefore, the CAN communication line between IPDM E/R and BCM is considered normal if the auto active test starts successfully.
- The auto active test facilitates troubleshooting if any systems controlled by IPDM E/R cannot be operated.

Diagnosis chart in auto active test mode

| Symptom | Inspection contents | Possible cause |
|---|--|--|
| Any of the following components do not operate <ul style="list-style-type: none"> • Parking lamp • License plate lamp • Side maker lamp • Tail lamp • Front fog lamp • Headlamp (HI, LO) • Front motor wiper | Perform auto active test. Does the applicable system operate? | YES BCM signal input circuit |
| | | NO <ul style="list-style-type: none"> • Lamp or motor • Lamp or motor ground circuit • Harness or connector between IPDM E/R and applicable system • IPDM E/R |
| A/C compressor does not operate | Perform auto active test. Does the magnet clutch operate? | YES <ul style="list-style-type: none"> • A/C amp. signal input circuit • CAN communication signal between A/C amp. and ECM • CAN communication signal between ECM and IPDM E/R |
| | | NO <ul style="list-style-type: none"> • Magnet clutch • Harness or connector between IPDM E/R and magnet clutch • IPDM E/R |
| Oil pressure warning lamp does not operate | Perform auto active test. Does the oil pressure warning lamp blink? | YES <ul style="list-style-type: none"> • Harness or connector between IPDM E/R and oil pressure switch • Oil pressure switch • IPDM E/R |
| | | NO <ul style="list-style-type: none"> • CAN communication signal between IPDM E/R and BCM • CAN communication signal between BCM and combination meter • Combination meter |

DIAGNOSIS SYSTEM (IPDM E/R)

< SYSTEM DESCRIPTION >

| Symptom | Inspection contents | Possible cause |
|------------------------------|--|---|
| Cooling fan does not operate | Perform auto active test. Does the cooling fan operate? | YES <ul style="list-style-type: none"> ECM signal input circuit CAN communication signal between ECM and IPDM E/R |
| | | NO <ul style="list-style-type: none"> Harness or connector between IPDM E/R and cooling fan motor Harness or connector between IPDM E/R and cooling fan relay Cooling fan motor Cooling fan relay IPDM E/R |

CONSULT Function (IPDM E/R)

INFOID:000000007805661

APPLICATION ITEM

CONSULT performs the following functions via CAN communication with IPDM E/R.

| Diagnosis mode | Description |
|--------------------------|---|
| Ecu Identification | Allows confirmation of IPDM E/R part number. |
| Self Diagnostic Result | Displays the diagnosis results judged by IPDM E/R. |
| Data Monitor | Displays the real-time input/output data from IPDM E/R input/output data. |
| Active Test | IPDM E/R can provide a drive signal to electronic components to check their operations. |
| CAN Diag Support Monitor | The results of transmit/receive diagnosis of CAN communication can be read. |

SELF DIAGNOSTIC RESULT

Refer to [PCS-23, "DTC Index"](#).

DATA MONITOR

Monitor item

| Monitor Item [Unit] | MAIN SIG- NALS | Description |
|----------------------------------|-------------------|---|
| MOTOR FAN REQ [1/2/3/4] | × | Displays the value of the cooling fan speed request signal received from ECM via CAN communication. |
| AC COMP REQ [Off/On] | × | Displays the status of the A/C compressor request signal received from ECM via CAN communication. |
| TAIL&CLR REQ [Off/On] | × | Displays the status of the position light request signal received from BCM via CAN communication. |
| HL LO REQ [Off/On] | × | Displays the status of the low beam request signal received from BCM via CAN communication. |
| HL HI REQ [Off/On] | × | Displays the status of the high beam request signal received from BCM via CAN communication. |
| FR FOG REQ [Off/On] | × | Displays the status of the front fog light request signal received from BCM via CAN communication. |
| FR WIP REQ [Stop/1LOW/Low/Hi] | × | Displays the status of the front wiper request signal received from BCM via CAN communication. |
| WIP AUTO STOP [STOP P/ACT P] | × | Displays the status of the front wiper auto stop signal judged by IPDM E/R. |
| WIP PROT [Off/BLOCK] | × | Displays the status of the front wiper fail-safe operation judged by IPDM E/R. |
| IGN RLY1 -REQ [Off/On] | | Displays the status of the ignition switch ON signal received from BCM via CAN communication. |
| IGN RLY [Off/On] | × | Displays the status of the ignition relay judged by IPDM E/R. |
| PUSH SW [Off/On] | | Displays the status of the push-button ignition switch judged by IPDM E/R. |

DIAGNOSIS SYSTEM (IPDM E/R)

< SYSTEM DESCRIPTION >

| Monitor Item [Unit] | MAIN SIG- NALS | Description |
|---|-------------------|---|
| INTER/NP SW [Off/On] | | Displays the status of the shift position judged by IPDM E/R. |
| ST RLY CONT [Off/On] | | Displays the status of the starter relay status signal received from BCM via CAN communication. |
| IHBT RLY -REQ [Off/On] | | Displays the status of the starter control relay signal received from BCM via CAN communication. |
| ST/INHI RLY [Off/ ST ON/INHI ON/UNKWN] | | Displays the status of the starter relay and starter control relay judged by IPDM E/R. |
| DETENT SW [Off/On] | | Displays the status of the CVT shift selector (detention switch) judged by IPDM E/R. |
| S/L RLY -REQ [Off/On] | | NOTE: The item is indicated, but not monitored. |
| S/L STATE [LOCK/UNLOCK/UNKWN] | | NOTE: The item is indicated, but not monitored. |
| DTRL REQ [Off/On] | | NOTE: The item is indicated, but not monitored. |
| OIL P SW [Open/Close] | | Displays the status of the oil pressure switch judged by IPDM E/R. |
| HOOD SW [Off/On] | | NOTE: The item is indicated, but not monitored. |
| HL WASHER REQ [Off/On] | | NOTE: The item is indicated, but not monitored. |
| THFT HRN REQ [Off/On] | | Displays the status of the theft warning horn request signal received from BCM via CAN communication. |
| HORN CHIRP [Off/On] | | Displays the status of the horn reminder signal received from BCM via CAN communication. |
| CRNRNG LMP REQ [Off/On] | | NOTE: The item is indicated, but not monitored. |

ACTIVE TEST

Test item

| Test item | Operation | Description |
|------------------|-----------|--|
| CORNERING LAMP | Off | NOTE: The item is indicated, but cannot be tested. |
| | LH | |
| | RH | |
| HORN | On | Operates horn relay for 20 ms. |
| FRONT WIPER | Off | OFF |
| | Lo | Operates the front wiper relay. |
| | Hi | Operates the front wiper relay and front wiper high relay. |
| MOTOR FAN | 1 | OFF |
| | 2 | Operates the cooling fan relay-1. |
| | 3 | Operates the cooling fan relay-2. |
| | 4 | Operates the cooling fan relay-2 and cooling fan relay-3. |
| HEAD LAMP WASHER | On | NOTE: The item is indicated, but cannot be tested. |

DIAGNOSIS SYSTEM (IPDM E/R)

< SYSTEM DESCRIPTION >

| Test item | Operation | Description | |
|----------------|-----------|---|---|
| EXTERNAL LAMPS | Off | OFF | A |
| | TAIL | Operates the tail lamp relay. | |
| | Lo | Operates the headlamp low relay. | B |
| | Hi | Operates the headlamp low relay and ON/OFF the headlamp high relay at 1 second intervals. | |
| | Fog | Operates the front fog lamp relay. | C |

D
E
F
G
H
I
J
K
M
N
O
P

WW

BCM, IPDM E/R

< ECU DIAGNOSIS INFORMATION >

ECU DIAGNOSIS INFORMATION

BCM, IPDM E/R

List of ECU Reference

INFOID:000000007566619

| ECU | Reference |
|----------|---|
| BCM | BCS-31, "Reference Value" |
| | BCS-53, "Fail-safe" |
| | BCS-53, "DTC Inspection Priority Chart" |
| | BCS-54, "DTC Index" |
| IPDM E/R | PCS-15, "Reference Value" |
| | PCS-21, "Fail-safe" |
| | PCS-23, "DTC Index" |

WIPER AND WASHER SYSTEM

< WIRING DIAGRAM >

WIRING DIAGRAM

WIPER AND WASHER SYSTEM

Wiring Diagram

INFOID:000000007566620

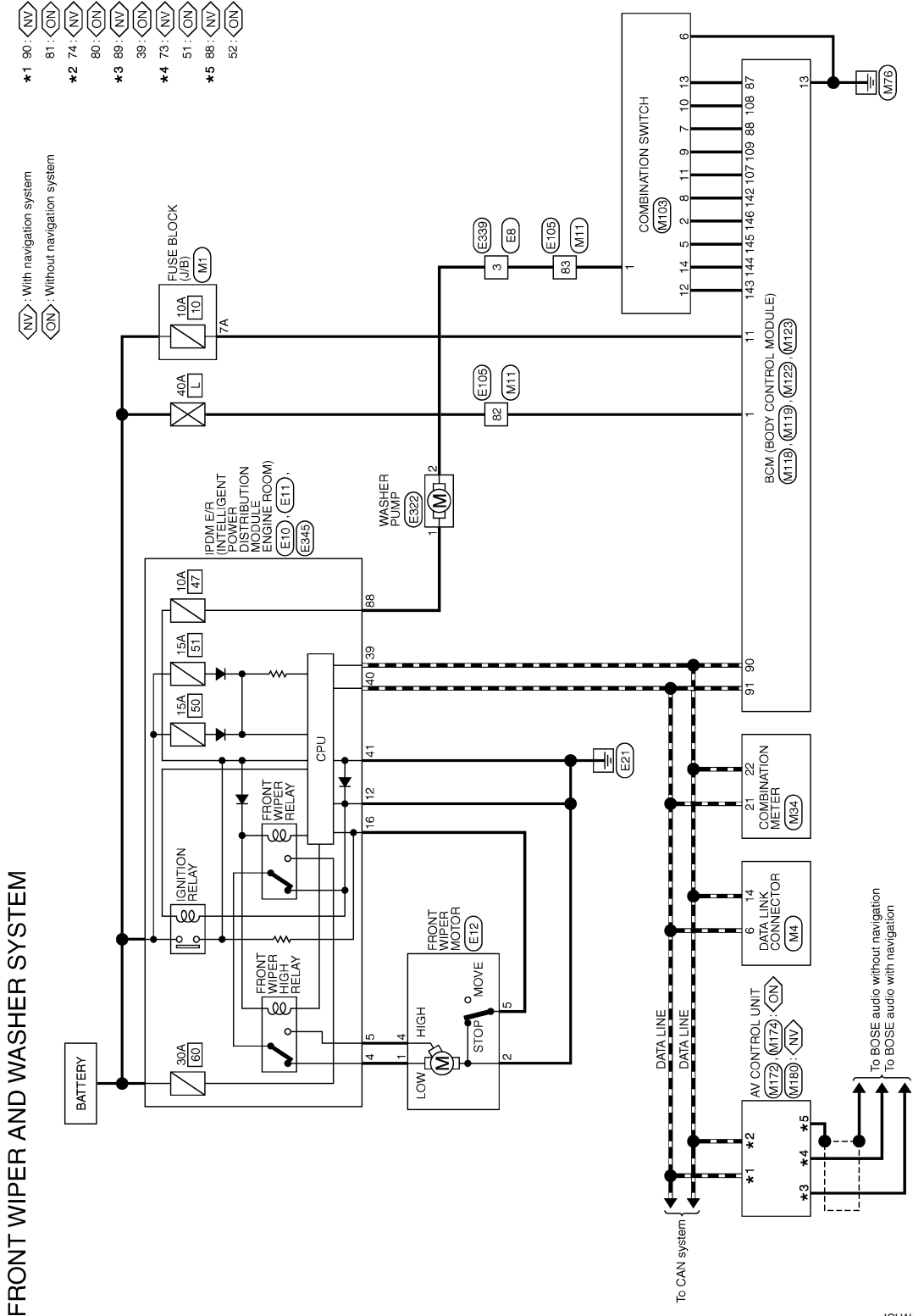

FRONT WIPER AND WASHER SYSTEM

2011/02/02

JCLWA5328GB

A
B
C
D
E
F
G
H
I
J
K
L
M
N
O
P

WW

DIAGNOSIS AND REPAIR WORK FLOW

< BASIC INSPECTION >

BASIC INSPECTION

DIAGNOSIS AND REPAIR WORK FLOW

Work Flow

INFOID:000000007805662

OVERALL SEQUENCE

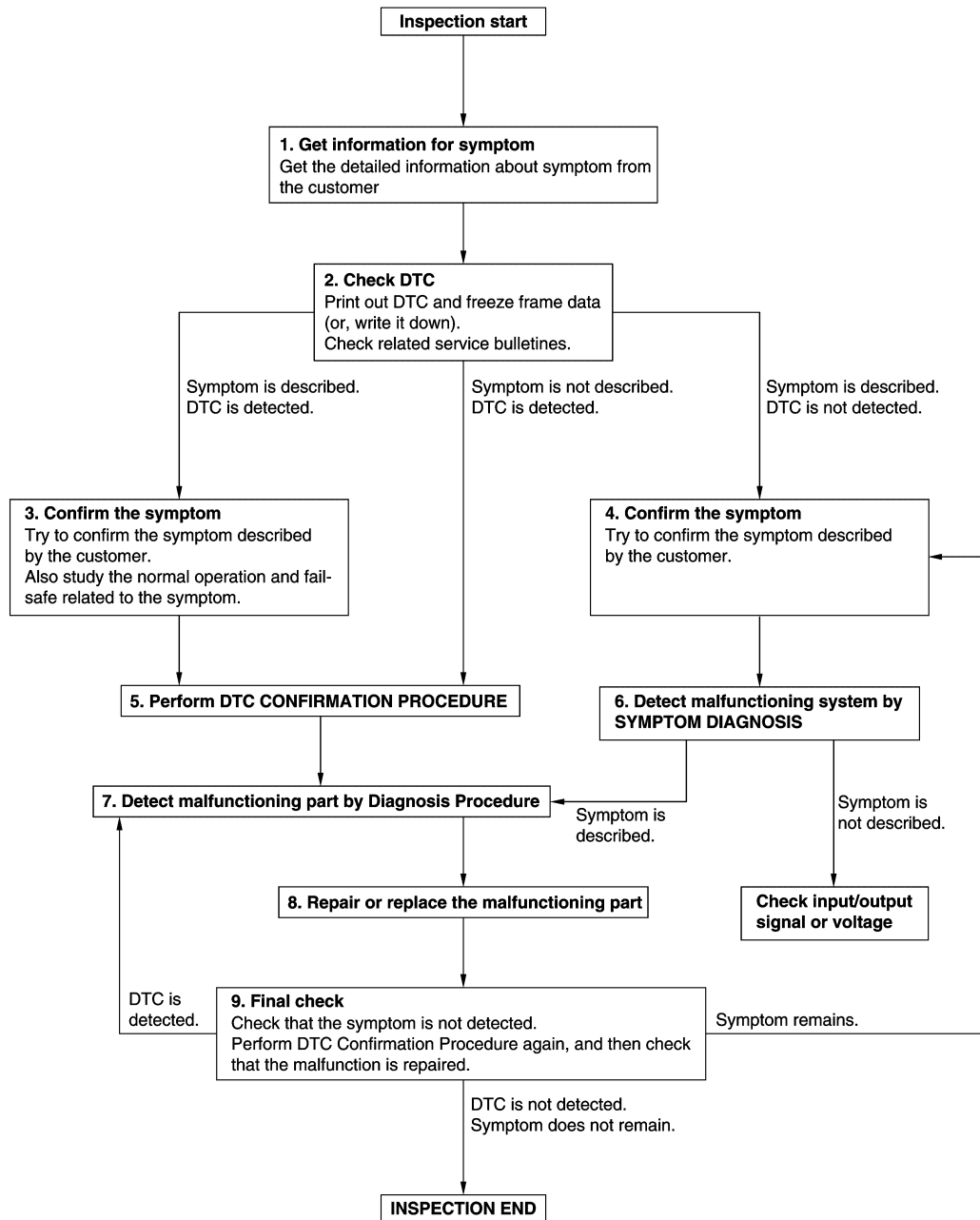

JMKIA8652GB

DETAILED FLOW

DIAGNOSIS AND REPAIR WORK FLOW

< BASIC INSPECTION >

1. GET INFORMATION FOR SYMPTOM

1. Get detailed information from the customer about the symptom (the condition and the environment when the incident/malfunction occurs).
2. Check operation condition of the function that is malfunctioning.

>> GO TO 2.

2. CHECK DTC

1. Check DTC.
2. Perform the following procedure if DTC is detected.
 - Record DTC and freeze frame data (Print them out using CONSULT.)
 - Erase DTC.
 - Study the relationship between the cause detected by DTC and the symptom described by the customer.
3. Check related service bulletins for information.

Are any symptoms described and any DTC detected?

Symptom is described, DTC is detected>>GO TO 3.

Symptom is described, DTC is not detected>>GO TO 4.

Symptom is not described, DTC is detected>>GO TO 5.

3. CONFIRM THE SYMPTOM

Try to confirm the symptom described by the customer.

Also study the normal operation and fail-safe related to the symptom.

Verify relation between the symptom and the condition when the symptom is detected.

>> GO TO 5.

4. CONFIRM THE SYMPTOM

Try to confirm the symptom described by the customer.

Verify relation between the symptom and the condition when the symptom is detected.

>> GO TO 6.

5. PERFORM DTC CONFIRMATION PROCEDURE

Perform DTC CONFIRMATION PROCEDURE for the detected DTC, and then check that DTC is detected again. At this time, always connect CONSULT to the vehicle, and check self diagnostic results in real time.

If two or more DTCs are detected, refer to [BCS-53. "DTC Inspection Priority Chart"](#) (BCM) or [PCS-23. "DTC Index"](#) (IPDM E/R), and determine trouble diagnosis order.

NOTE:

- Freeze frame data is useful if the DTC is not detected.
- Perform Component Function Check if DTC CONFIRMATION PROCEDURE is not included on Service Manual. This simplified check procedure is an effective alternative though DTC cannot be detected during this check.

If the result of Component Function Check is NG, it is the same as the detection of DTC by DTC CONFIRMATION PROCEDURE.

Is DTC detected?

YES >> GO TO 7.

NO >> Check according to [GI-40. "Intermittent Incident"](#).

6. DETECT MALFUNCTIONING SYSTEM BY SYMPTOM DIAGNOSIS

Detect malfunctioning system according to SYMPTOM DIAGNOSIS based on the confirmed symptom in step 4, and determine the trouble diagnosis order based on possible causes and symptom.

Is the symptom described?

YES >> GO TO 7.

NO >> Monitor input data from related sensors or check voltage of related module terminals using CONSULT.

7. DETECT MALFUNCTIONING PART BY DIAGNOSIS PROCEDURE

DIAGNOSIS AND REPAIR WORK FLOW

< BASIC INSPECTION >

Inspect according to Diagnosis Procedure of the system.

Is malfunctioning part detected?

YES >> GO TO 8.

NO >> Check according to [GI-40. "Intermittent Incident"](#).

8. REPAIR OR REPLACE THE MALFUNCTIONING PART

1. Repair or replace the malfunctioning part.
2. Reconnect parts or connectors disconnected during Diagnosis Procedure again after repair and replacement.
3. Check DTC. If DTC is detected, erase it.

>> GO TO 9.

9. FINAL CHECK

When DTC is detected in step 2, perform DTC CONFIRMATION PROCEDURE again, and then check that the malfunction is repaired securely.

When symptom is described by the customer, refer to confirmed symptom in step 3 or 4, and check that the symptom is not detected.

Is DTC detected and does symptom remain?

YES-1 >> DTC is detected: GO TO 7.

YES-2 >> Symptom remains: GO TO 4.

NO >> Before returning the vehicle to the customer, always erase DTC.

FRONT WIPER MOTOR LO CIRCUIT

< DTC/CIRCUIT DIAGNOSIS >

DTC/CIRCUIT DIAGNOSIS

FRONT WIPER MOTOR LO CIRCUIT

Component Function Check

INFOID:000000007566622

1. CHECK FRONT WIPER LO OPERATION

CONSULT ACTIVE TEST

1. Select "FRONT WIPER" of IPDM E/R active test item.
2. With operating the test item, check front wiper operation.

Lo : Front wiper (LO) operation

Off : Stop the front wiper.

Is front wiper (LO) operation normally?

- YES >> Front wiper motor LO circuit is normal.
 NO >> Refer to [WW-23, "Diagnosis Procedure"](#).

Diagnosis Procedure

INFOID:000000007566623

1. CHECK FRONT WIPER MOTOR (LO) OUTPUT VOLTAGE

1. Turn ignition switch OFF, and wait for 20 seconds or more.
2. Disconnect front wiper motor connector.
3. Turn ignition switch ON, and wait for 10 seconds.
4. Check voltage between front wiper motor harness connector and ground.

| (+) | | (-) | Voltage (Approx.) |
|-------------------|----------|--------|-------------------------------|
| Front wiper motor | | | |
| Connector | Terminal | | |
| E12 | 1 | Ground | Battery voltage (10 seconds)* |

*: According to front wiper protection function, IPDM E/R supplies voltage for 10 seconds (battery voltage) and then stops for 20 seconds (0 V). This operations repeats 5 times, and then IPDM E/R stops voltage supply. To perform the check again, turn ignition switch OFF, wait for 20 seconds or more, and then perform the check.

Is the inspection result normal?

- YES >> Replace front wiper motor.
 NO >> GO TO 2.

2. CHECK FRONT WIPER MOTOR (LO) CIRCUIT

1. Turn ignition switch OFF.
2. Disconnect IPDM E/R connector.
3. Check continuity between IPDM E/R harness connector and front wiper motor harness connector.

| IPDM E/R | | Front wiper motor | | Continuity |
|-----------|----------|-------------------|----------|------------|
| Connector | Terminal | Connector | Terminal | |
| E10 | 4 | E12 | 1 | Existed |

4. Check continuity between IPDM E/R harness connector and ground.

| IPDM E/R | | Ground | Continuity |
|-----------|----------|--------|-------------|
| Connector | Terminal | | |
| E10 | 4 | | Not existed |

Is the inspection result normal?

- YES >> Replace IPDM E/R.
 NO >> Repair or replace harness.

FRONT WIPER MOTOR HI CIRCUIT

< DTC/CIRCUIT DIAGNOSIS >

FRONT WIPER MOTOR HI CIRCUIT

Component Function Check

INFOID:000000007566624

1. CHECK FRONT WIPER HI OPERATION

CONSULT ACTIVE TEST

1. Select "FRONT WIPER" of IPDM E/R active test item.
2. With operating the test item, check front wiper operation.

Hi : Front wiper (HI) operation

Off : Stop the front wiper.

Is front wiper (HI) operation normally?

- YES >> Front wiper motor HI circuit is normal.
 NO >> Refer to [WW-24, "Diagnosis Procedure"](#).

Diagnosis Procedure

INFOID:000000007566625

1. CHECK FRONT WIPER MOTOR (HI) OUTPUT VOLTAGE

CONSULT ACTIVE TEST

1. Turn ignition switch OFF, and wait for 20 seconds or more.
2. Disconnect front wiper motor connector.
3. Turn ignition switch ON.
4. Select "FRONT WIPER" of IPDM E/R active test item.
5. With operating the test item, check voltage between front wiper motor harness connector and ground.

| (+) | | (-) | Condition | | Voltage (Approx.) |
|-------------------|----------|--------|-------------|----|-------------------------------|
| Front wiper motor | | | | | |
| Connector | Terminal | | | | |
| E12 | 4 | Ground | FRONT WIPER | Hi | Battery voltage (10 seconds)* |

*: According to front wiper protection function, IPDM E/R supplies voltage for 10 seconds (battery voltage) and then stops for 20 seconds (0 V). This operations repeats 5 times, and then IPDM E/R stops voltage supply. To perform the check again, turn ignition switch OFF, wait for 20 seconds or more, and then perform the check.

Is the inspection result normal?

- YES >> Replace front wiper motor.
 NO >> GO TO 2.

2. CHECK FRONT WIPER MOTOR (HI) CIRCUIT

1. Turn ignition switch OFF.
2. Disconnect IPDM E/R connector.
3. Check continuity between IPDM E/R harness connector and front wiper motor harness connector.

| IPDM E/R | | Front wiper motor | | Continuity |
|-----------|----------|-------------------|----------|------------|
| Connector | Terminal | Connector | Terminal | |
| E10 | 5 | E12 | 4 | Existed |

4. Check continuity between IPDM E/R harness connector and ground.

| IPDM E/R | | Ground | Continuity |
|-----------|----------|--------|-------------|
| Connector | Terminal | | |
| E10 | 5 | | Not existed |

Is the inspection result normal?

- YES >> Replace IPDM E/R.
 NO >> Repair or replace harness.

FRONT WIPER STOP POSITION SIGNAL CIRCUIT

< DTC/CIRCUIT DIAGNOSIS >

FRONT WIPER STOP POSITION SIGNAL CIRCUIT

Component Function Check

INFOID:000000007566626

1. CHECK FRONT WIPER STOP POSITION SIGNAL

CONSULT DATA MONITOR

1. Select "WIP AUTO STOP" of IPDM E/R data monitor item.
2. Operate the front wiper.
3. With the front wiper operation, check the monitor status.

| Monitor item | Condition | | Monitor status |
|---------------|-------------------|----------------------|----------------|
| WIP AUTO STOP | Front wiper motor | Stop position | STOP P |
| | | Except stop position | ACT P |

Is the status of item normal?

- YES >> Front wiper stop position signal circuit is normal.
 NO >> Refer to [WW-25. "Diagnosis Procedure"](#).

Diagnosis Procedure

INFOID:000000007566627

1. CHECK IPDM E/R OUTPUT VOLTAGE

1. Turn ignition switch OFF.
2. Disconnect front wiper motor connector.
3. Turn ignition switch ON.
4. Check voltage between front wiper motor harness connector and ground.

| (+) | | (-) | Voltage (Approx.) |
|-------------------|----------|--------|-------------------|
| Front wiper motor | | | |
| Connector | Terminal | Ground | Battery voltage |
| E12 | 5 | | |

Is the inspection result normal?

- YES >> Replace front wiper motor.
 NO >> GO TO 2.

2. CHECK FRONT WIPER MOTOR CIRCUIT

1. Turn ignition switch OFF.
2. Disconnect IPDM E/R connector.
3. Check continuity between IPDM E/R harness connector and front wiper motor harness connector.

| IPDM E/R | | Front wiper motor | | Continuity |
|-----------|----------|-------------------|----------|------------|
| Connector | Terminal | Connector | Terminal | |
| E10 | 16 | E12 | 5 | Existed |

4. Check continuity between IPDM E/R harness connector and ground.

| IPDM E/R | | Ground | Continuity |
|-----------|----------|--------|-------------|
| Connector | Terminal | | |
| E10 | 16 | | Not existed |

Is the inspection result normal?

- YES >> Replace IPDM E/R.
 NO >> Repair or replace harness.

A
B
C
D
E
F
G
H
I
J
K
M
N
O
P

WW

FRONT WIPER MOTOR GROUND CIRCUIT

< DTC/CIRCUIT DIAGNOSIS >

FRONT WIPER MOTOR GROUND CIRCUIT

Diagnosis Procedure

INFOID:000000007566628

1. CHECK FRONT WIPER MOTOR GROUND CIRCUIT

1. Turn ignition switch OFF.
2. Disconnect front wiper motor connector.
3. Check continuity between front wiper motor harness connector and ground.

| Front wiper motor | | Ground | Continuity |
|-------------------|----------|--------|------------|
| Connector | Terminal | | Existed |
| E12 | 2 | | |

Is the inspection result normal?

- YES >> INSPECTION END
NO >> Repair or replace harness.

WASHER SWITCH

< DTC/CIRCUIT DIAGNOSIS >

WASHER SWITCH

Description

INFOID:000000007566629

Washer switch is integrated with combination switch.

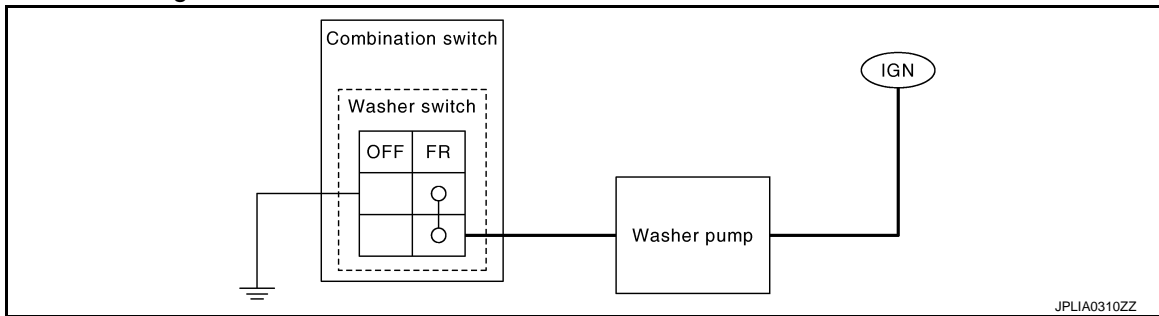

Component Inspection

INFOID:000000007566630

1. CHECK WIPER SWITCH

1. Turn the ignition switch OFF.
2. Disconnect combination switch connector.
3. Check continuity between the combination switch terminals.

| Combination switch | | Condition | Continuity |
|--------------------|---|------------------------|------------|
| Terminal | | | |
| 1 | 6 | Front washer switch ON | Existed |

Does continuity exist?

- YES >> Wiper and washer switch is normal.
 NO >> Replace wiper and washer switch.

A
B
C
D
E
F
G
H
I
J
K
M
N
O
P

WW

WIPER AND WASHER SYSTEM SYMPTOMS

< SYMPTOM DIAGNOSIS >

SYMPTOM DIAGNOSIS

WIPER AND WASHER SYSTEM SYMPTOMS

Symptom Table

INFOID:000000007566631

| Symptom | | Probable malfunction location | Inspection item | |
|--|---------------------------|---|--|--|
| Front wiper does not operate | HI only | <ul style="list-style-type: none"> Combination switch Harness between combination switch and BCM BCM | Combination switch Refer to BCS-74, "Symptom Table" . | |
| | | <ul style="list-style-type: none"> IPDM E/R Harness between IPDM E/R and front wiper motor Front wiper motor | Front wiper motor (HI) circuit Refer to WW-24, "Component Function Check" . | |
| | | Front wiper request signal <ul style="list-style-type: none"> BCM IPDM E/R | IPDM E/R Data monitor "FR WIP REQ" | |
| | LO and INT | <ul style="list-style-type: none"> Combination switch Harness between combination switch and BCM BCM | Combination switch Refer to BCS-74, "Symptom Table" . | |
| | | <ul style="list-style-type: none"> IPDM E/R Harness between IPDM E/R and front wiper motor Front wiper motor | Front wiper motor (LO) circuit Refer to WW-23, "Component Function Check" . | |
| | | Front wiper request signal <ul style="list-style-type: none"> BCM IPDM E/R | IPDM E/R Data monitor "FR WIP REQ" | |
| | INT only | <ul style="list-style-type: none"> Combination switch Harness between combination switch and BCM BCM | Combination switch Refer to BCS-74, "Symptom Table" . | |
| | | Front wiper request signal <ul style="list-style-type: none"> BCM IPDM E/R | IPDM E/R Data monitor "FR WIP REQ" | |
| | HI, LO and INT | SYMPTOM DIAGNOSIS Refer to WW-31, "Diagnosis Procedure" . | | |
| | Front wiper does not stop | HI only | <ul style="list-style-type: none"> Combination switch BCM | Combination switch Refer to BCS-74, "Symptom Table" . |
| Front wiper request signal <ul style="list-style-type: none"> BCM IPDM E/R | | | IPDM E/R Data monitor "FR WIP REQ" | |
| IPDM E/R | | | — | |
| LO only | | <ul style="list-style-type: none"> Combination switch BCM | Combination switch Refer to BCS-74, "Symptom Table" . | |
| | | Front wiper request signal <ul style="list-style-type: none"> BCM IPDM E/R | IPDM E/R Data monitor "FR WIP REQ" | |
| | | IPDM E/R | — | |
| INT only | | <ul style="list-style-type: none"> Combination switch BCM | Combination switch refer to BCS-74, "Symptom Table" . | |
| | | Front wiper request signal <ul style="list-style-type: none"> BCM IPDM E/R | IPDM E/R Data monitor "FR WIP REQ" | |

WIPER AND WASHER SYSTEM SYMPTOMS

< SYMPTOM DIAGNOSIS >

| Symptom | Probable malfunction location | Inspection item | |
|--|--|--|--|
| Front wiper does not operate normally | Intermittent adjustment cannot be performed | <ul style="list-style-type: none"> • Combination switch • Harness between combination switch and BCM • BCM Combination switch Refer to BCS-74, "Symptom Table" . | |
| | | BCM — | |
| | Intermittent control linked with vehicle speed cannot be performed | Check the wiper setting is linked with vehicle speed. Refer to WW-11, "WIPER : CONSULT Function - WIPER" . | |
| | Service positioning operation does not operate | <ul style="list-style-type: none"> • Combination switch • BCM • IPDM E/R Combination switch Refer to BCS-74, "Symptom Table" . | |
| | Wiper is not linked to the washer operation | <ul style="list-style-type: none"> • Combination switch • Harness between combination switch and BCM • BCM Combination switch Refer to BCS-74, "Symptom Table" . | |
| | | BCM — | |
| Does not return to stop position [Repeatedly operates for 10 seconds and then stops for 20 seconds. After that, it stops the operation. (Fail-safe)] | <ul style="list-style-type: none"> • IPDM E/R • Harness between IPDM E/R and front wiper motor • Front wiper motor Front wiper stop position signal circuit Refer to WW-25, "Component Function Check" . | | |

A
B
C
D
E
F
G
H
I
J
K
L
M
N
O
P

WW

NORMAL OPERATING CONDITION

< SYMPTOM DIAGNOSIS >

NORMAL OPERATING CONDITION

Description

INFOID:000000007566632

FRONT WIPER MOTOR PROTECTION FUNCTION

- IPDM E/R may stop the front wiper to protect the front wiper motor if any obstruction (operation resistance) such as a large amount of snow is detected during the front wiper operation.
- At that time turn OFF the front wiper and remove the foreign object. Then wait for approximately 20 seconds or more and reactivate the front wiper. The wiper will operate normally.

FRONT WIPER DOES NOT OPERATE

< SYMPTOM DIAGNOSIS >

FRONT WIPER DOES NOT OPERATE

Description

INFOID:000000007566633

The front wiper does not operate under any operation conditions.

Diagnosis Procedure

INFOID:000000007566634

1. CHECK WIPER RELAY OPERATION

CONSULT ACTIVE TEST

1. Select "FRONT WIPER" of IPDM E/R active test item.
2. With operating the test item, check front wiper operation.

Lo : Front wiper LO operation

Hi : Front wiper HI operation

Off : Stop the front wiper.

Is front wiper operation normally?

YES >> GO TO 4.

NO >> GO TO 2.

2. CHECK FRONT WIPER MOTOR FUSE

Check that the following fuses is not fusing.

| Unit | Location | No. | Capacity |
|-------------------|----------|-----|----------|
| Front wiper motor | IPDM E/R | 60 | 30 A |
| Washer pump | | 47 | 10 A |

Is the inspection result normal?

YES >> GO TO 3.

NO >> Replace the fuse after repairing the applicable circuit.

3. CHECK FRONT WIPER MOTOR GROUND CIRCUIT

Check front wiper motor ground circuit. Refer to [WW-26, "Diagnosis Procedure"](#).

Is the inspection result normal?

YES >> GO TO 4.

NO >> Repair or replace harness.

4. CHECK FRONT WIPER REQUEST SIGNAL INPUT

CONSULT DATA MONITOR

1. Select "FR WIP REQ" of IPDM E/R data monitor item.
2. Switch the front wiper switch to HI and LO.
3. With operating the front wiper switch, check the status of "FR WIP REQ".

| Monitor item | Condition | Monitor status | |
|--------------|-----------------------|----------------|------|
| FR WIP REQ | Front wiper switch HI | On | Hi |
| | | Off | Stop |
| | Front wiper switch LO | On | Low |
| | | Off | Stop |

Is the inspection result normal?

YES >> Replace IPDM E/R.

NO >> GO TO 5.

5. CHECK COMBINATION SWITCH

Perform the inspection of the combination switch. Refer to [BCS-74, "Symptom Table"](#).

Is combination switch normal?

FRONT WIPER DOES NOT OPERATE

< SYMPTOM DIAGNOSIS >

- YES >> Replace BCM. Refer to [BCS-76. "Removal and Installation"](#).
- NO >> Repair or replace the applicable parts.

WASHER TANK

< REMOVAL AND INSTALLATION >

REMOVAL AND INSTALLATION

WASHER TANK

Exploded View

INFOID:000000007566635

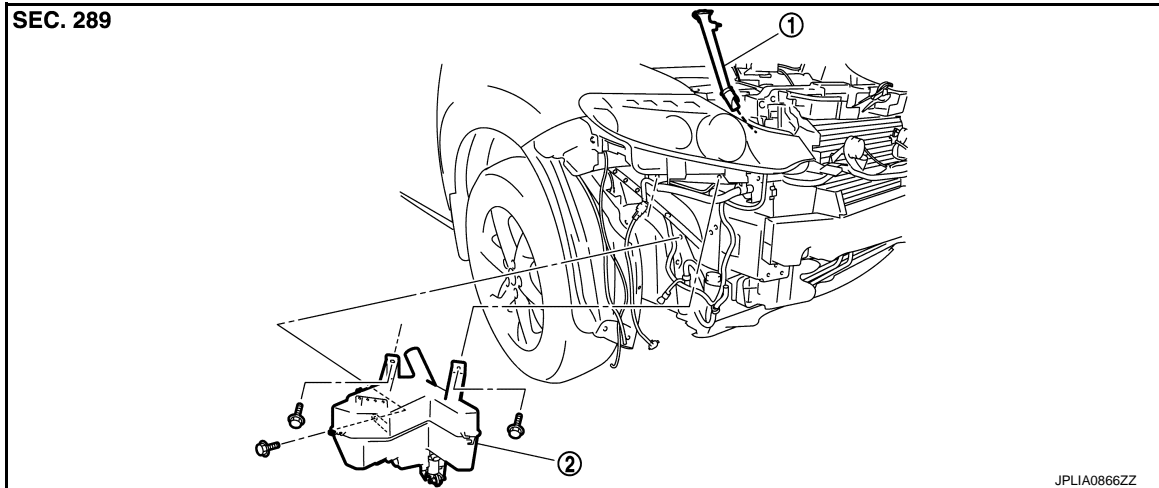

1. Washer tank inlet

2. Washer tank

Removal and Installation

INFOID:000000007566636

REMOVAL

1. Remove the clip (A).
2. Pull out the washer tank inlet (1) from the washer tank.

← : Vehicle front

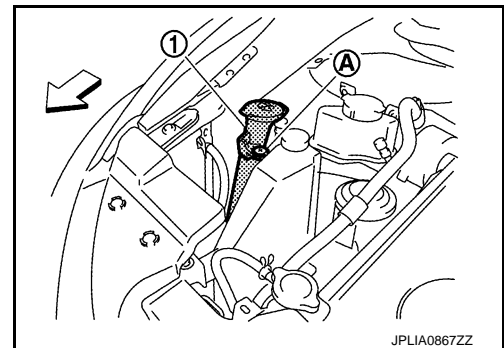

3. Remove the front bumper fascia. Refer to [EXT-13. "Removal and Installation"](#).
4. Disconnect washer pump connector.
5. Disconnect washer level switch connector.
6. Remove washer tube.
7. Remove washer tank mounting bolts.
8. Remove the washer tank from the vehicle.

INSTALLATION

Note the following, and install in the reverse order of removal.

CAUTION:

Add water up to the top of the washer tank inlet after installing. Check that there is no leakage.

WASHER PUMP

< REMOVAL AND INSTALLATION >

WASHER PUMP

Exploded View

INFOID:000000007566637

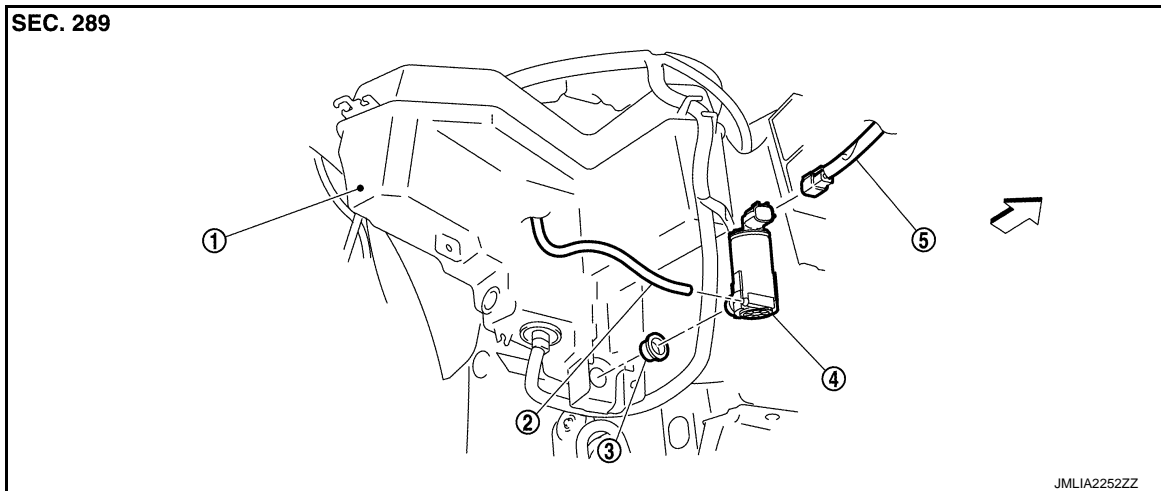

- | | | |
|----------------|----------------------------------|------------|
| 1. Washer tank | 2. Washer tube | 3. Packing |
| 4. Washer pump | 5. Washer pump harness connector | |

⇨ : Vehicle front

Removal and Installation

INFOID:000000007566638

REMOVAL

1. Remove the fender protector RH (front). Refer to [EXT-26, "FENDER PROTECTOR : Removal and Installation"](#).
2. Disconnect washer pump connector.
3. Remove washer tube.
4. Remove washer pump from the washer tank.
5. Remove the packing from the washer tank.

INSTALLATION

Note the following, and install in the reverse order of removal.

CAUTION:

Never twist the packing when installing the washer pump.

WASHER LEVEL SWITCH

< REMOVAL AND INSTALLATION >

WASHER LEVEL SWITCH

Removal and Installation

INFOID:000000007566639

The washer level switch must be replaced together with the washer tank as an assembly. Refer to [WW-33](#), "[Removal and Installation](#)".

A
B
C
D
E
F
G
H
I
J
K
M
N
O
P

WW

WASHER NOZZLE & TUBE

< REMOVAL AND INSTALLATION >

WASHER NOZZLE & TUBE

Exploded View

INFOID:000000007566640

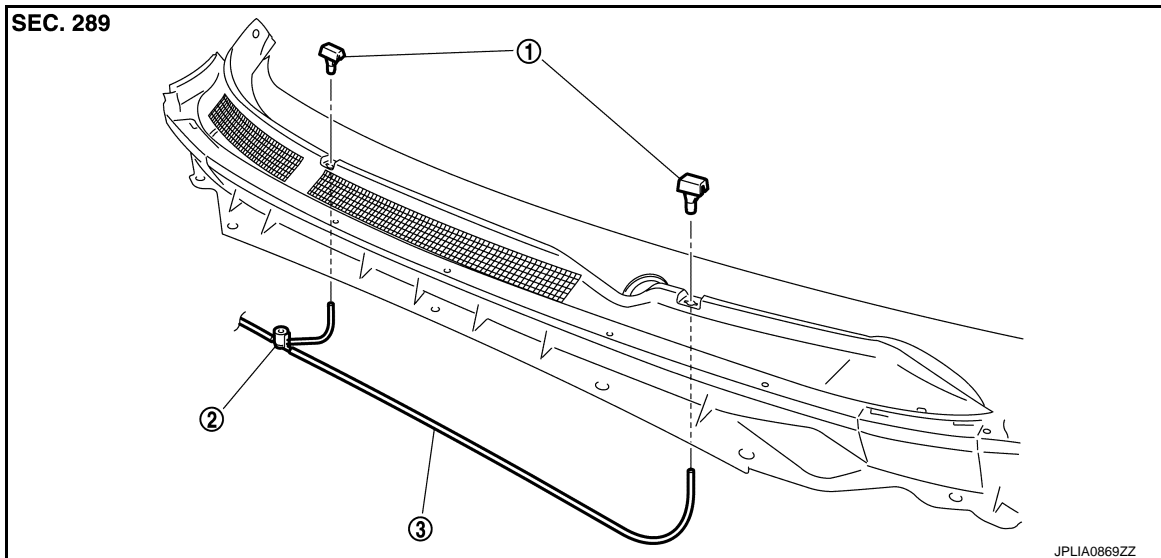

1. Front washer nozzle

2. Check valve

3. Front washer tube

Hydraulic Layout

INFOID:000000007566641

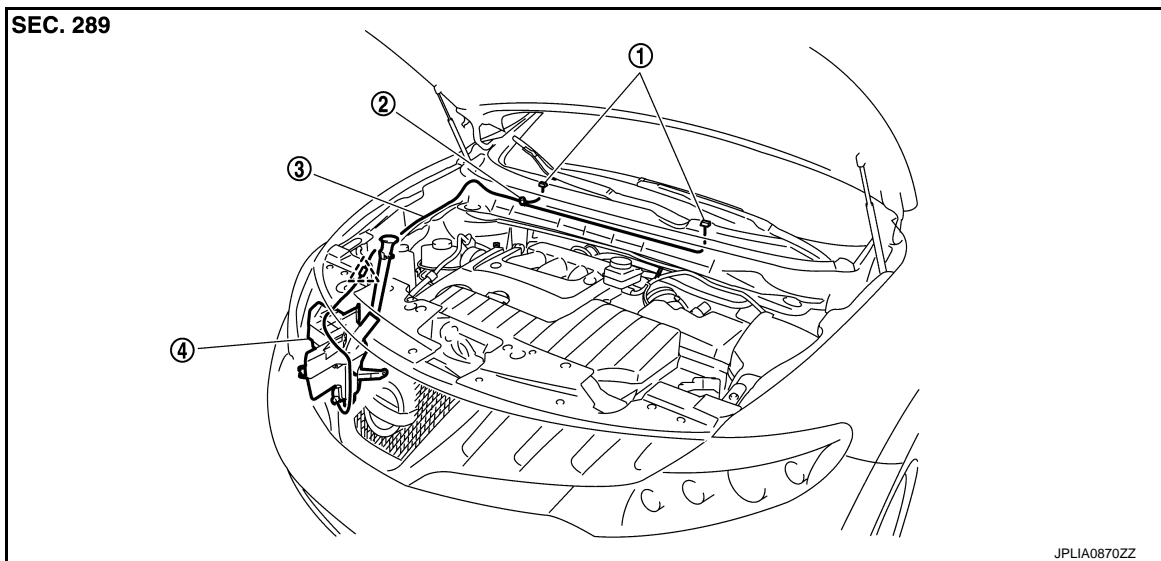

1. Front washer nozzle

2. Check valve

3. Front washer tube

4. Washer tank

 : Clip

WASHER NOZZLE

WASHER NOZZLE : Removal and Installation

INFOID:000000007566642

REMOVAL

1. Remove cowl top cover. Refer to [EXT-20. "Removal and Installation"](#).
2. Disconnect front washer tube from front washer nozzle.

WASHER NOZZLE & TUBE

< REMOVAL AND INSTALLATION >

- While pressing pawl (A) on the cowl top cover front side of front washer nozzle (1), remove front washer nozzle from cowl top cover.

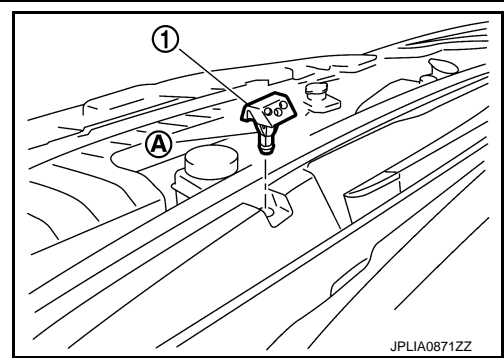

INSTALLATION

Note the following, and install in the reverse order of removal.

CAUTION:

The spray positions differ, check that left and right nozzles are installed correctly.

WASHER NOZZLE : Inspection and Adjustment

INFOID:000000007566643

INSPECTION

Check valve Inspection

Check that air can pass through the hose by blowing forward (toward the nozzle), and check that air cannot pass through by sucking.

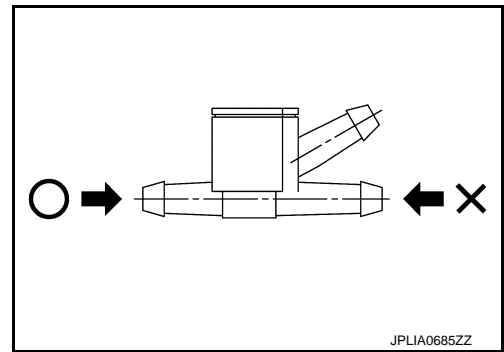

ADJUSTMENT

Washer Nozzle Spray Position Adjustment

Adjust spray positions to match the positions shown in the figure.

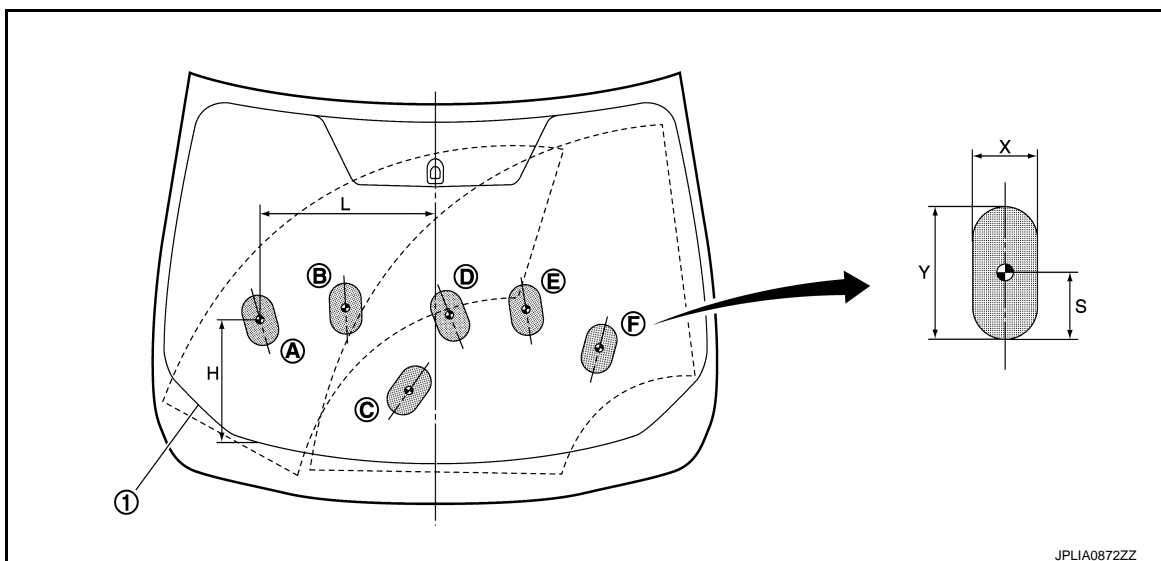

1. Black printed frame line

 : Spray area

 : Target spray position

A
B
C
D
E
F
G
H
I
J
K
M
N
O
P

WW

WASHER NOZZLE & TUBE

< REMOVAL AND INSTALLATION >

Unit: mm (in)

| Spray position | H | L | X | Y | S |
|----------------|-------------|-------------|-----------|------------|-----------|
| A | 285 (11.22) | 429 (16.89) | 80 (3.15) | 130 (5.12) | 65 (2.56) |
| B | 398 (15.67) | 232 (9.13) | 80 (3.15) | 130 (5.12) | 65 (2.56) |
| C | 185 (7.28) | 69 (2.72) | 80 (3.15) | 130 (5.12) | 65 (2.56) |
| D | 381 (15.00) | 37 (1.46) | 80 (3.15) | 130 (5.12) | 65 (2.56) |
| E | 398 (15.67) | 232 (9.13) | 80 (3.15) | 130 (5.12) | 65 (2.56) |
| F | 296 (11.65) | 421 (16.57) | 80 (3.15) | 130 (5.12) | 65 (2.56) |

Insert a needle or similar object (A) into the spray opening (1) and move up/down and left/right to adjust the spray position.

NOTE:

If wax or dust gets into the nozzle, remove wax or dust with a needle or small pin.

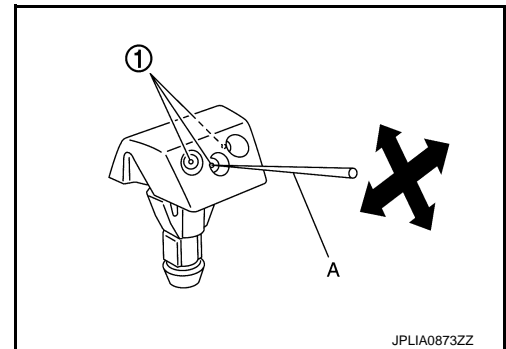

WASHER TUBE

WASHER TUBE : Removal and Installation

INFOID:000000007566644

REMOVAL

1. Fully open hood.
2. Remove washer tube from the washer pump. Refer to [WW-34, "Removal and Installation"](#).
3. Remove front washer tube from the front washer nozzle. Refer to [WW-36, "WASHER NOZZLE : Removal and Installation"](#).
4. Remove front washer tube mounting clip (A). Remove front washer tube (1) from the vehicle.

⇐ : Vehicle front

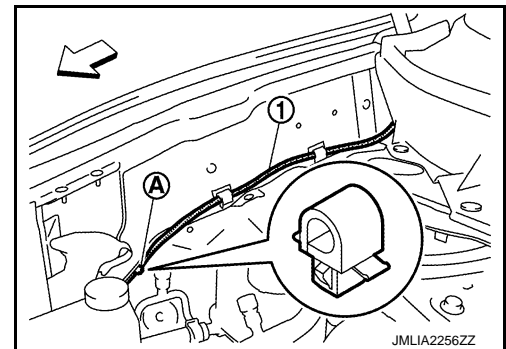

INSTALLATION

Install in the reverse order of removal.

FRONT WIPER ARM

< REMOVAL AND INSTALLATION >

FRONT WIPER ARM

Exploded View

INFOID:000000007566645

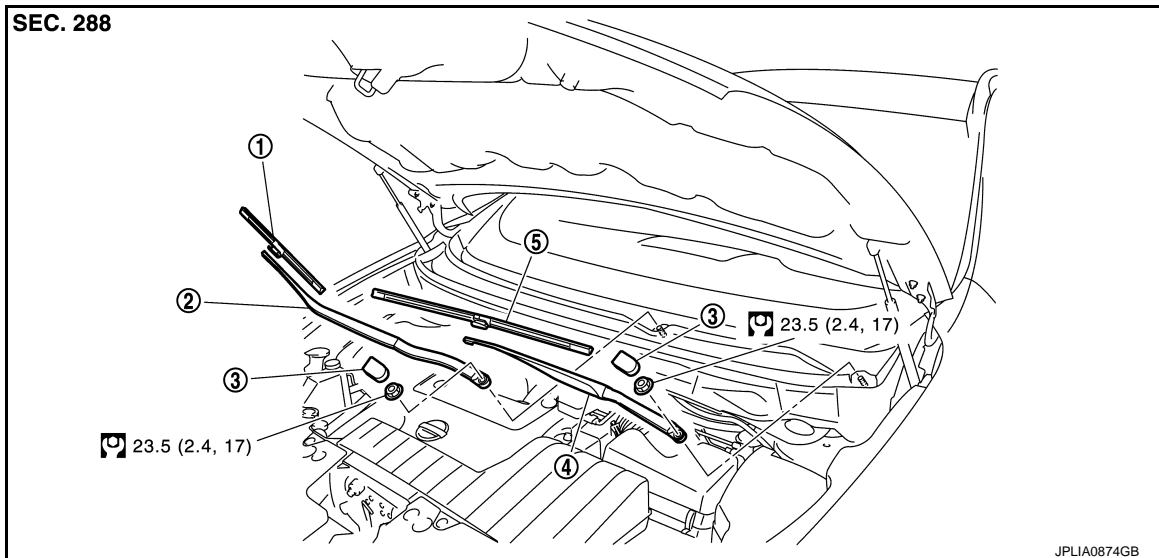

- 1. Front wiper blade RH
- 2. Front wiper arm RH
- 3. Front wiper arm cap
- 4. Front wiper arm LH
- 5. Front wiper blade LH

Refer to [GI-4, "Components"](#) for symbols in the figure.

Removal and Installation

INFOID:000000007566646

REMOVAL

1. Operate the front wiper to move it to the auto stop position.
2. Fully open hood.
3. Remove front wiper arm caps.
4. Remove the front wiper arm mounting nuts.
5. Raise front wiper arm, and remove front wiper arm from the vehicle.

INSTALLATION

1. Clean wiper arm mount as shown in the figure to prevent nuts from being loosened.

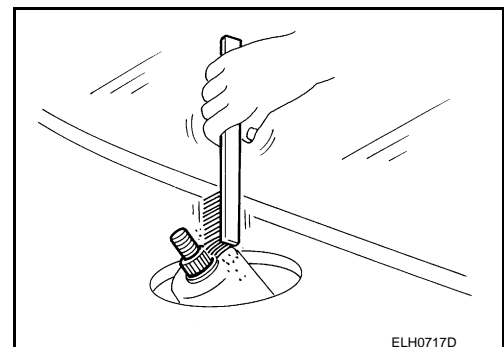

2. Operate the front wiper motor to move the front wiper to the auto stop position.
3. Adjust the front wiper blade position. Refer to [WW-40, "Adjustment"](#).
4. Install the front wiper arms by tightening the mounting nuts.
5. Inject the washer fluid.
6. Operate the front wiper to move it to the auto stop position.
7. Check that the front wiper blades stop at the specified position.

FRONT WIPER ARM

< REMOVAL AND INSTALLATION >

8. Install front wiper arm caps.

Adjustment

INFOID:000000007566647

WIPER BLADE POSITION ADJUSTMENT

Clearance between the end of cowl top cover and the top of front wiper blade center

Standard clearance

R : 51.0 ± 7.5 mm (2.008 ± 0.295 in)

L : 48.0 ± 7.5 mm (1.890 ± 0.295 in)

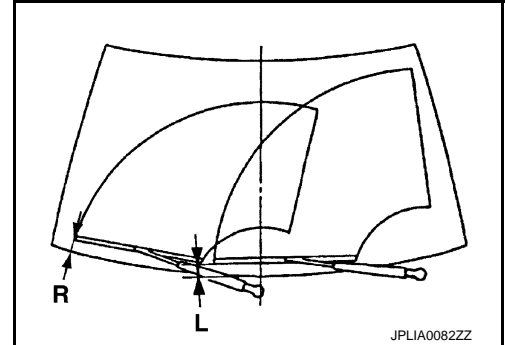

WIPER BLADE

< REMOVAL AND INSTALLATION >

WIPER BLADE

Exploded View

INFOID:000000007566648

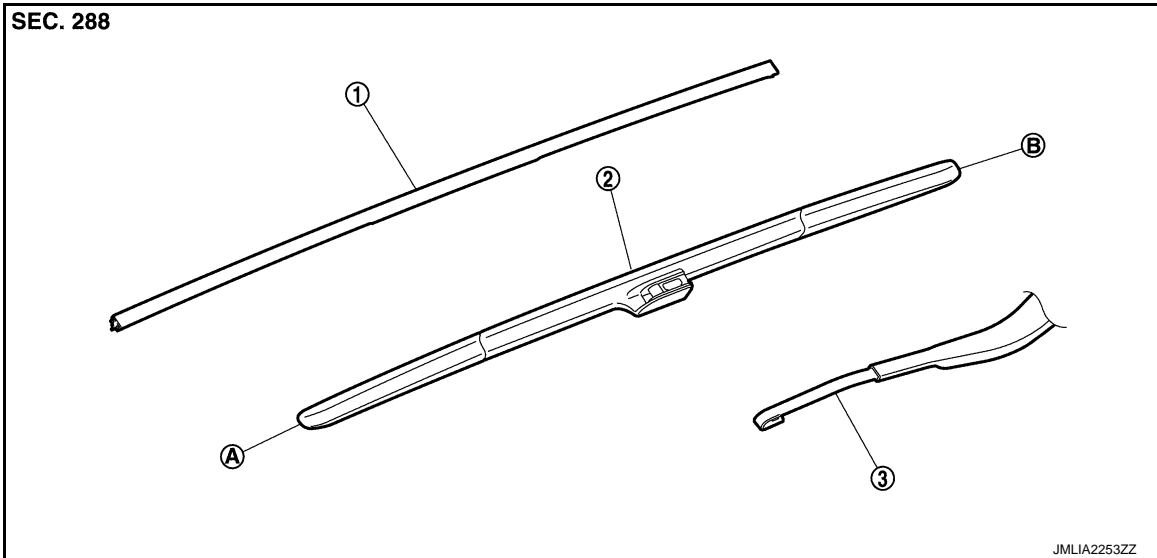

- 1. Wiper refill
- A. Wiper blade tip

- 2. Wiper blade
- B. Wiper blade end

- 3. Wiper arm

Removal and Installation

INFOID:000000007566649

REMOVAL

1. Lift up wiper arm, and set to the position where wiper arm can be locked back.
2. Press and hold lever (A) of wiper blade (1). Pull in the direction indicated by the arrow as shown in the figure, and remove wiper blade from wiper arm (2).

CAUTION:

Wrap wiper arm using a shop cloth so that wiper blade does not damage windshield glass.

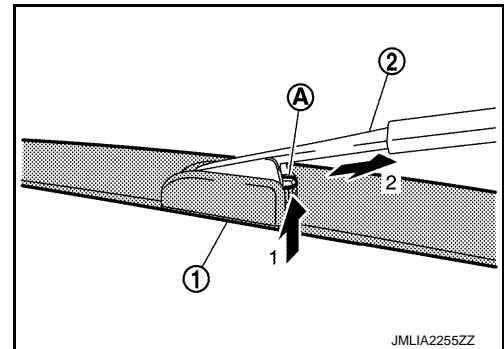

INSTALLATION

Installation is the reverse order of removal.

Replacement

INFOID:000000007566650

1. Remove wiper blade from the wiper arm.

WIPER BLADE

< REMOVAL AND INSTALLATION >

- From portion (A) of wiper refill (1), disengage wiper blade portion (B) and remove wiper refill in the direction indicated by the arrow as shown in the figure.

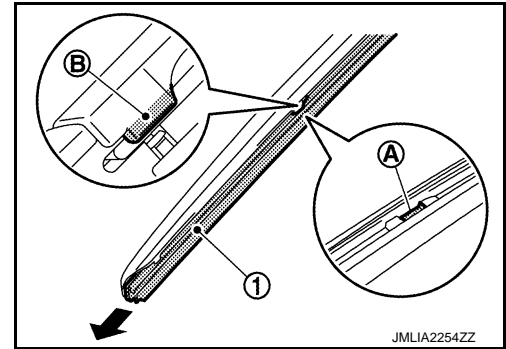

NOTE:

When the vertebra is detached.

- Insert the vertebra (1) into the wiper blade to the same bending direction.
- If a vertebra has a notch, fit it to a protrusion inside the wiper refill.

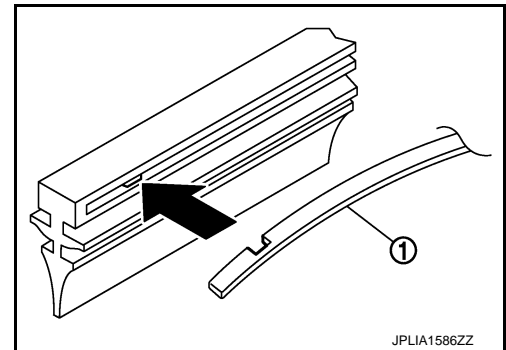

FRONT WIPER DRIVE ASSEMBLY

< REMOVAL AND INSTALLATION >

FRONT WIPER DRIVE ASSEMBLY

Exploded View

INFOID:000000007566651

REMOVAL VIEW

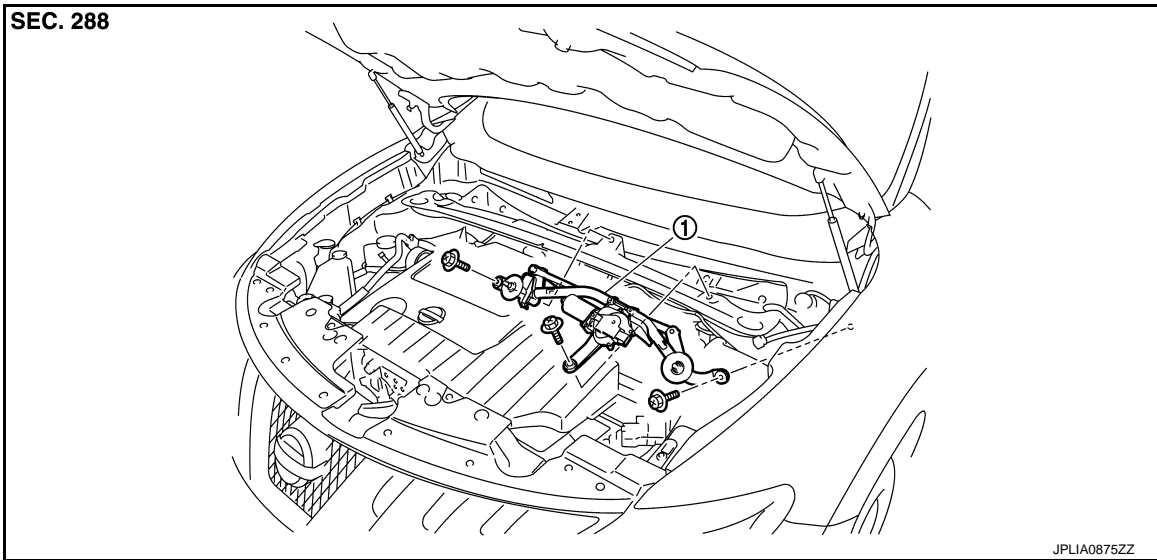

1. Front wiper drive assembly

DISASSEMBLY VIEW

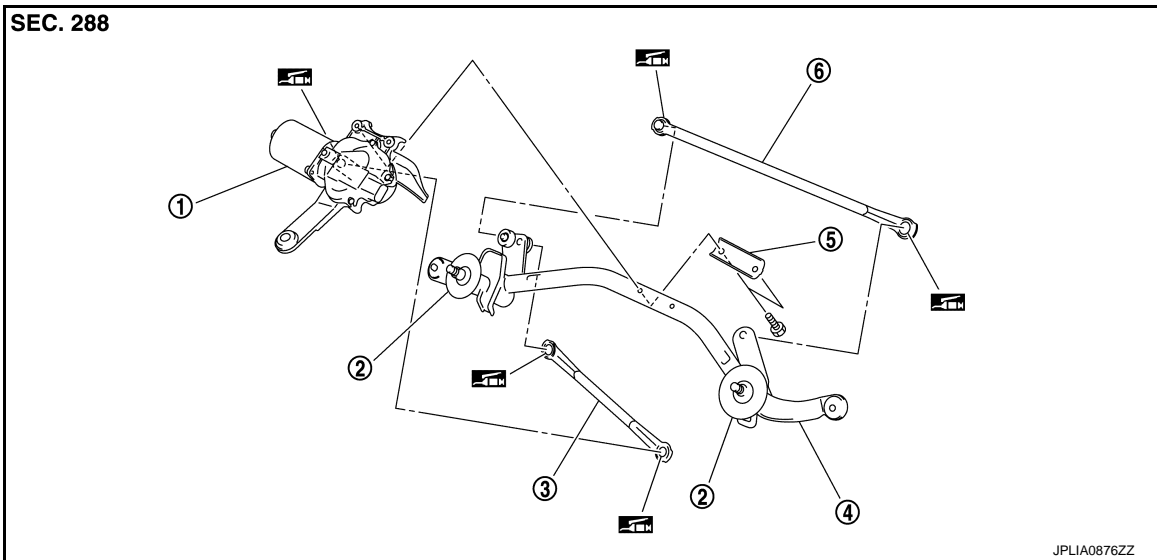

- | | | |
|----------------------|---------------|--------------------------|
| 1. Front wiper motor | 2. Shaft seal | 3. Front wiper linkage 2 |
| 4. Front wiper frame | 5. Bracket | 6. Front wiper linkage 1 |

: Multi-purpose grease or an equivalent

Removal and Installation

INFOID:000000007566652

REMOVAL

1. Remove front wiper arm. Refer to [WW-39, "Removal and Installation"](#).
2. Remove cowl top cover. Refer to [EXT-20, "Removal and Installation"](#).
3. Remove bolts from the front wiper drive assembly.

A
B
C
D
E
F
G
H
I
J
K
L
M
N
O
P

WW

FRONT WIPER DRIVE ASSEMBLY

< REMOVAL AND INSTALLATION >

4. Disconnect the front wiper motor connector.
5. Remove front wiper drive assembly from the vehicle.

INSTALLATION

1. Install the front wiper drive assembly to the vehicle.
2. Connect the front wiper motor connector.
3. Operate the front wiper to move it to the auto stop position.
4. Install the cowl top cover. Refer to [EXT-20, "Removal and Installation"](#).
5. Install front wiper arms. Refer to [WW-39, "Removal and Installation"](#).

Disassembly and Assembly

INFOID:000000007566653

DISASSEMBLY

1. Remove the front wiper linkage 1 and 2 from the front wiper drive assembly.
CAUTION:
Never bend the linkage or damage the plastic part of the ball joint when removing the front wiper linkage.
2. Remove the front wiper motor mounting screws, and then remove the front wiper motor from the front wiper frame.

ASSEMBLY

1. Connect the front wiper motor connector.
2. Operate the front wiper to move it to the auto stop position.
3. Disconnect the front wiper motor connector.
4. Install front wiper motor to front wiper frame.
5. Install the front wiper linkage 2 to the front wiper motor and the front wiper frame.
6. Install the front wiper linkage 1 to the front wiper frame.
CAUTION:
 - **Never drop front wiper motor or cause it to come into contact with other parts.**
 - **Be careful for the grease condition at the front wiper motor and front wiper linkage joint (retainer). Apply multi-purpose grease or an equivalent if necessary.**

WIPER AND WASHER SWITCH

< REMOVAL AND INSTALLATION >

WIPER AND WASHER SWITCH

Exploded View

INFOID:000000007566654

Refer to [BCS-77, "Exploded View"](#).

A

B

C

D

E

F

G

H

I

J

K

WW

M

N

O

P