

SECTION **PB**
PARKING BRAKE SYSTEM

A
B
C
D
E
PB
G
H
I
J
K
L
M
N
O
P

CONTENTS

PREPARATION	2	Removal and Installation	6
PREPARATION	2	Adjustment	7
Commercial Service Tool	2	PARKING BRAKE SHOE	8
PERIODIC MAINTENANCE	3	Exploded View	8
PARKING BRAKE SYSTEM	3	Removal and Installation	8
Inspection and Adjustment	3	Inspection and Adjustment	9
PARKING BRAKE SHOE	5	SERVICE DATA AND SPECIFICATIONS (SDS)	11
Adjustment	5	SERVICE DATA AND SPECIFICATIONS (SDS)	11
REMOVAL AND INSTALLATION	6	Parking Drum Brake	11
PARKING BRAKE CONTROL	6	Parking Brake Control	11
Exploded View	6		

PREPARATION

< PREPARATION >

PREPARATION

PREPARATION

Commercial Service Tool

INFOID:000000008459985

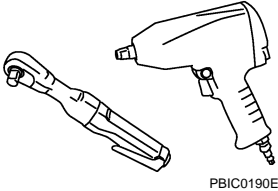
Tool name	Description
Power tool 	Loosening bolts and nuts

PARKING BRAKE SYSTEM

< PERIODIC MAINTENANCE >

PERIODIC MAINTENANCE

PARKING BRAKE SYSTEM

Inspection and Adjustment

INFOID:000000008459986

INSPECTION

Pedal Stroke

1. Operate the parking brake pedal with a force of 196 N (20 kg, 44 lb). Check that the pedal stroke is within the specified number of notches. (Check it by listening to the clicks of the ratchet.)

Standard

Number of notches : Refer to [PB-11, "Parking Brake Control"](#).

2. When brake warning lamp turns ON, check that the pedal stroke is within the specified number of notches. (Check it by listening to the clicks of the ratchet.)

Standard

Number of notches : Refer to [PB-11, "Parking Brake Control"](#).

Inspect Components

- Check each component for installation condition such as looseness.
- Check the parking brake pedal assembly for bend, damage and cracks. Replace if necessary.
- Check the cables for wear, damage and cracks. Replace if necessary.
- Check the parking brake switch, and replace it if necessary. Refer to [BRC-83, "Component Inspection"](#).

ADJUSTMENT

1. Fix the disc rotor using wheel nuts.
2. Remove fuse block lid. Refer to [IP-12, "Exploded View"](#).
3. Release the parking brake pedal (1) by turning the adjusting nut (2) with a deep socket wrench and loosening the cable.

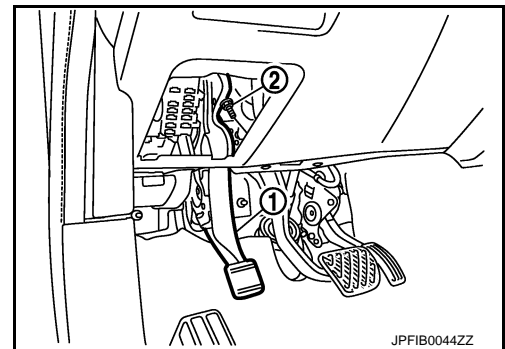

4. Remove the adjusting hole plug from the disc rotor. Turn the adjuster (1) in the direction (A) as shown in the figure using a suitable tool until the disc rotor is locked.
5. Turn back the adjuster 5 or 6 notches from the locked position.
6. Rotate the disc rotor to check that there is no drag. Install the adjusting hole plug.
7. Adjust the cable with the following procedure.
 - a. Operate the parking brake pedal with a force of 490 N (50 kg, 110 lb) for 10 strokes or more.
 - b. Adjust the parking brake pedal stroke by turning the adjusting nut with a deep socket wrench.

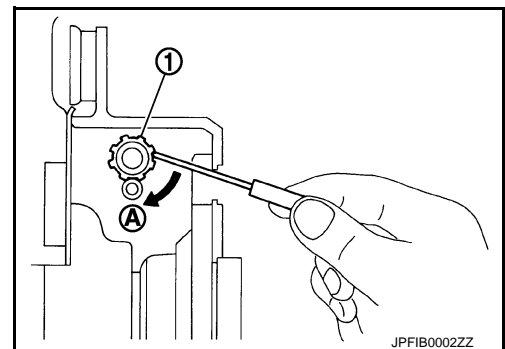

CAUTION:

Never reuse the adjusting nut if the nut is removed.

- c. Operate the parking brake pedal with a force of 196 N (20 kg, 44 lb). Check that the pedal stroke is within the specified number of notches. (Check it by listening to the clicks of the ratchet.)

PARKING BRAKE SYSTEM

< PERIODIC MAINTENANCE >

Standard

Number of notches : Refer to [PB-11, "Parking Brake Control"](#).

- d. Rotate the disc rotor with the parking brake pedal released and check that there is no drag. Refer to [PB-9, "Inspection and Adjustment"](#).

PARKING BRAKE SHOE

< PERIODIC MAINTENANCE >

PARKING BRAKE SHOE

Adjustment

INFOID:000000008459987

1. Adjust parking brake pedal stroke. Refer to [PB-3, "Inspection and Adjustment"](#).
2. Perform parking brake break-in (drag on) operation by driving vehicle under the following conditions:
 - Drive forward
 - Vehicle speed: Approx. 40 km/h (25 MPH) set (constant and forward)
 - Parking brake operating force: Approx. 145 N (15 kg, 33 lb)
 - Time: Approx. 10 sec.

CAUTION:

To prevent lining from getting too hot, allow a cool off period of approximately 5 minutes after every break-in operation.

3. After the break-in procedure, check parking pedal stroke of parking brake.

CAUTION:

If it is out of the specification, adjust again. Refer to [PB-3, "Inspection and Adjustment"](#).

A
B
C
D
E
G
H
I
J
K
L
M
N
O
P

PB

PARKING BRAKE CONTROL

< REMOVAL AND INSTALLATION >

REMOVAL AND INSTALLATION

PARKING BRAKE CONTROL

Exploded View

INFOID:000000008459988

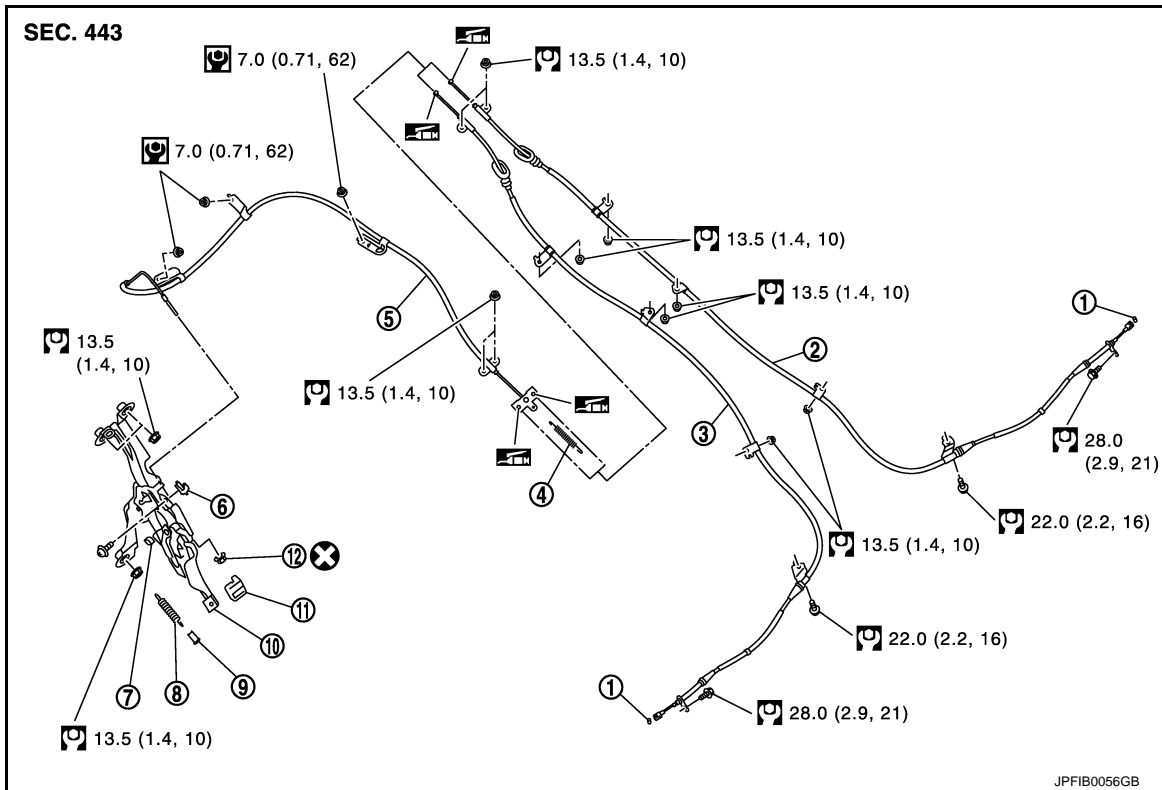

- | | | |
|----------------------------------|--------------------|-------------------------|
| 1. Pin | 2. Rear cable (RH) | 3. Rear cable (LH) |
| 4. Return spring | 5. Front cable | 6. Parking brake switch |
| 7. Stopper rubber | 8. Return spring | 9. Silencer |
| 10. Parking brake pedal assembly | 11. Pedal pad | 12. Adjusting nut |

 Apply multi-purpose grease.

Refer to [GI-4. "Components"](#) for symbols not described on the above.

Removal and Installation

INFOID:000000008459989

REMOVAL

1. Remove rear tires with power tool.
2. Remove instrument panel assembly. Refer to [IP-12. "Exploded View"](#).
3. Disconnect parking brake switch harness connector.
4. Remove adjusting nut and loosen front cable.
5. Remove parking brake pedal assembly.
6. Remove rear ventilator duct. Refer to [VTL-8. "Exploded View"](#).
7. Separate front cable from rear cable, and remove front cable and return spring.
8. Remove parking brake shoe, and remove rear cable from toggle lever. Refer to [PB-8. "Exploded View"](#).
9. Remove rear cable mounting bolts and nuts, pull out rear cable from vehicle.

INSTALLATION

Note the following, Install the reverse order of the removal.

- Never reuse the adjusting nut.

PARKING BRAKE CONTROL

< REMOVAL AND INSTALLATION >

Adjustment

INFOID:000000008459990

ADJUSTMENT AFTER INSTALLATION

Adjust the parking brake pedal stroke. Refer to [PB-3. "Inspection and Adjustment"](#).

A

B

C

D

E

PB

G

H

I

J

K

L

M

N

O

P

PARKING BRAKE SHOE

< REMOVAL AND INSTALLATION >

PARKING BRAKE SHOE

Exploded View

INFOID:000000008459991

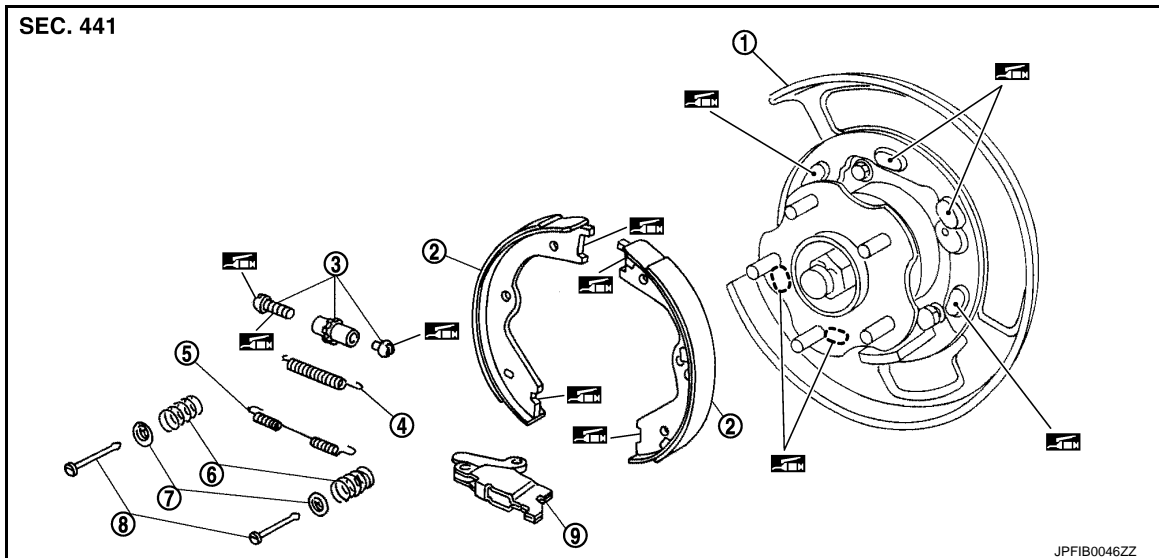

- | | | |
|--------------------|-----------------------|-----------------------|
| 1. Back plate | 2. Parking brake shoe | 3. Adjuster |
| 4. Adjuster spring | 5. Return spring | 6. Anti-rattle spring |
| 7. Retainer | 8. Anti-rattle pin | 9. Toggle lever |

 Apply PBC (Poly Butyl Cuprysil) grease or silicone-based grease.

Removal and Installation

INFOID:000000008459992

REMOVAL

WARNING:

Since dust covering the parking brake has an affect on human body, the dust must be removed with a dust collector. Never splatter the dust with an air blow gun.

1. Remove rear tires with power tool.
2. Remove disc rotor. Refer to [BR-47. "BRAKE CALIPER ASSEMBLY : Removal and Installation"](#).

CAUTION:

Parking brake completely in the released position.

3. If disc rotor cannot be removed, remove as follows:
 - a. Fix the disc rotor with wheel nuts and remove the adjusting hole plug.
 - b. Using suitable tool, rotate adjuster (1) in direction (B) to retract and loosen parking brake shoe.
4. Remove anti-rattle pins, retainers, anti-rattle spring, adjuster spring and return springs.

CAUTION:

Never drop the removed parts.

5. Remove parking brake shoes, adjuster assembly and toggle lever.

CAUTION:

- The parking brake shoes for the front side are made of different materials from those for the rear side. Never misidentify them when removing.
- Never drop the removed parts.

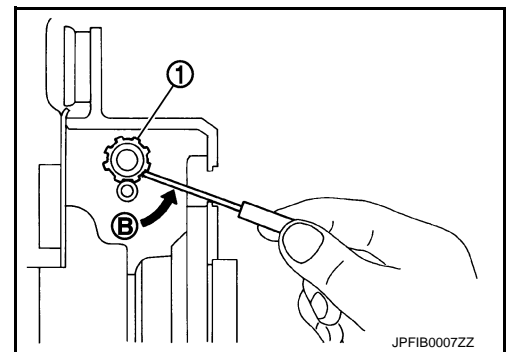

INSTALLATION

Install in the reverse order of removal.

- Apply PBC (Poly Butyl Cuprysil) grease or silicone-based grease to the back plate and brake shoe.

PARKING BRAKE SHOE

< REMOVAL AND INSTALLATION >

CAUTION:

The parking brake shoes for the front side are made of different materials from those for the rear side. Never misidentify them when removing and replacing.

- Assemble adjusters so that threaded part is expanded when rotating it in the direction shown by arrow.

- A : For RH brake
- B : For LH brake
- ↔ : Vehicle front
- ← : Adjuster expands

- Shorten adjuster by rotating it.
- When disassembling, apply PBC (Poly Butyl Cuprysil) grease or silicone-based grease to threads.
- Check parking brake shoe sliding surface and drum inner surface for grease. Wipe it off if it adhere on the surfaces.

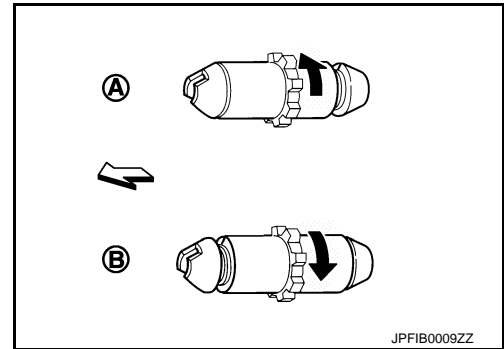

Inspection and Adjustment

INFOID:000000008459993

INSPECTION

Brake Lining Thickness Inspection

- Check thickness (A) of brake lining.

Limit

A : Refer to [PB-11, "Parking Drum Brake"](#).

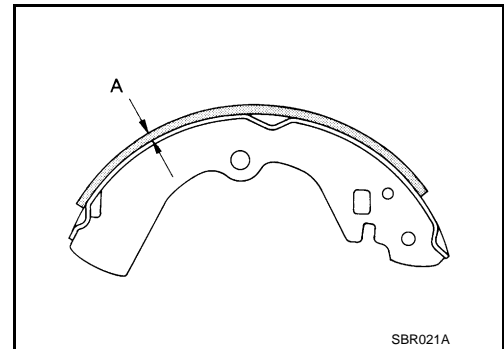

Drum Inner Diameter Inspection

- Check inner diameter (B) of drum.

Limit

B : Refer to [PB-11, "Parking Drum Brake"](#).

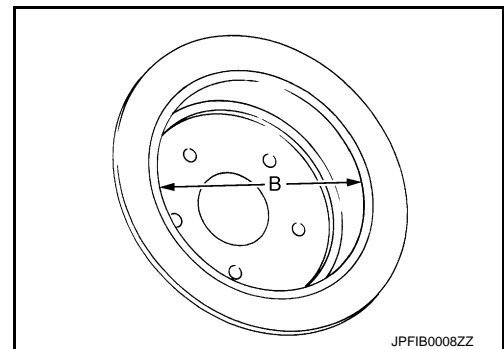

Other Inspections

- Check brake lining for excessive wear, damage, and peeling. Replace if necessary.
- Check parking brake shoe sliding surface for excessive wear and damage. Replace if necessary.
- Check anti-rattle pin and retainer for excessive wear, damage and rust. Replace if necessary.
- Check adjuster spring, anti-rattle spring and return springs for settling, excessive wear, damage, and rust. Replace if necessary.
- Check adjuster for smoothness. Replace if necessary.
- Check toggle lever for excessive wear, damage and rust. Replace if necessary.
- Visually check inside of the drum for excessive wear, cracks, and damage with a pair of vernier calipers. Replace if necessary.

ADJUSTMENT

- Adjust the parking brake pedal stroke. Refer to [PB-3, "Inspection and Adjustment"](#).
- Check a drag of the parking brake.

PARKING BRAKE SHOE

< REMOVAL AND INSTALLATION >

CAUTION:

If any drag is found, inspect the rear disc brake. Refer to [BR-48, "BRAKE CALIPER ASSEMBLY : Disassembly and Assembly"](#).

SERVICE DATA AND SPECIFICATIONS (SDS)

< SERVICE DATA AND SPECIFICATIONS (SDS)

SERVICE DATA AND SPECIFICATIONS (SDS)

SERVICE DATA AND SPECIFICATIONS (SDS)

Parking Drum Brake

INFOID:0000000008459994

Unit: mm (in)

Item		Limit
Brake lining	Wear thickness	1.5 (0.059)
Drum	Wear limit of inner diameter	191 (7.52)

Parking Brake Control

INFOID:0000000008459995

Item	Standard
Number of notches [under force of 196 N (20 kg, 44 lb)]	5 – 6 notches
Number of notches when brake warning lamp turns ON	1 notch

A
B
C
D
E
PB
G
H
I
J
K
L
M
N
O
P