

SECTION MA
MAINTENANCE

A
B
C
D
E
F
G
H
I
J
K
MA
M

CONTENTS

PREPARATION	3	INSTALLATION	20
Special Service Tools	3	Checking EVAP Vapor Lines	20
Commercial Service Tools	3	CHASSIS AND BODY MAINTENANCE	21
GENERAL MAINTENANCE	4	Checking Exhaust System	21
Explanation of General Maintenance	4	Checking CVT Fluid	21
PERIODIC MAINTENANCE	6	FLUID LEVEL CHECK	21
Introduction of Periodic Maintenance	6	FLUID CONDITION CHECK	22
Schedule 1	7	Changing CVT Fluid	22
EMISSION CONTROL SYSTEM MAINTENANCE	7	Checking Transfer Oil	22
CHASSIS AND BODY MAINTENANCE	8	Changing Transfer Oil	23
Schedule 2	8	Checking Propeller Shaft	23
EMISSION CONTROL SYSTEM MAINTENANCE	8	Checking Differential Gear Oil	23
CHASSIS AND BODY MAINTENANCE	9	Changing Differential Gear Oil	24
RECOMMENDED FLUIDS AND LUBRICANTS	10	Balancing Wheels (Bonding Weight Type)	24
Fluids and Lubricants	10	REMOVAL	24
SAE Viscosity Number	11	WHEEL BALANCE ADJUSTMENT	24
GASOLINE ENGINE OIL	11	Tire Rotation	25
Anti-Freeze Coolant Mixture Ratio	11	Checking Brake Fluid Level and Leaks	26
ENGINE MAINTENANCE	12	Checking Brake Lines and Cables	26
Checking Drive Belts	12	Changing Brake Fluid	26
Tension Adjustment	12	Checking Disc Brake	26
ALTERNATOR AND A/C COMPRESSOR BELT	13	ROTOR	26
POWER STEERING OIL PUMP BELT	13	CALIPER	27
Changing Engine Coolant	14	PAD	27
DRAINING ENGINE COOLANT	14	Checking Steering Gear and Linkage	27
REFILLING ENGINE COOLANT	14	STEERING GEAR	27
FLUSHING COOLING SYSTEM	16	STEERING LINKAGE	27
Checking Fuel Lines	16	Checking Power Steering Fluid and Lines	27
Changing Air Cleaner Filter	16	Axle and Suspension Parts	28
VISCOUS PAPER TYPE	16	Drive Shaft	28
Changing Engine Oil	17	Lubricating Locks, Hinges and Hood Latch	29
Changing Oil Filter	18	Checking Seat Belt, Buckles, Retractors, Anchors and Adjusters	29
REMOVAL	18	SERVICE DATA AND SPECIFICATIONS (SDS)	31
INSTALLATION	18	Standard and Limit	31
INSPECTION AFTER INSTALLATION	18	BELT DEFLECTION AND TENSION	31
Changing Spark Plugs (Platinum-Tipped Type)	19	ENGINE COOLANT CAPACITY (APPROXIMATE)	31
REMOVAL	19	RADIATOR	31
INSPECTION AFTER REMOVAL	19	ENGINE OIL CAPACITY (APPROXIMATE)	31

SPARK PLUG (PLATINUM-TIPPED TYPE) 31

WHEEL BALANCE32

Tightening Torque32

PREPARATION

PREPARATION

PFP:00002

Special Service Tools

NLS0004G

The actual shapes of Kent-Moore tools may differ from those of special service tools illustrated here.

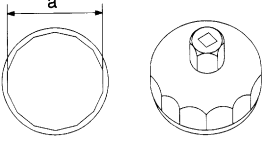
Tool number (Kent-Moore No.) Tool name	Description
KV10115801 (J38956) Oil filter wrench  <p style="text-align: center;">S-NT375</p>	Removing and installing oil filter a: 64.3 mm (2.531 in)

Commercial Service Tools

NLS0004H

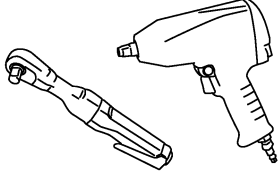
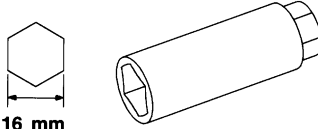
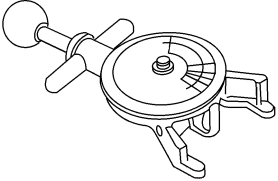
(Kent-Moore No.) Tool name	Description
(—) Power tool  <p style="text-align: center;">PBIC0190E</p>	Loosening nuts and bolts
(—) Spark plug wrench  <p style="text-align: center;">S-NT047</p>	Removing and installing spark plug
(BT3373-F) Belt tension gauge  <p style="text-align: center;">AMA126</p>	Checking drive belt tension

A
B
C
D
E
F
G
H
I
J
K
MA
M

GENERAL MAINTENANCE

GENERAL MAINTENANCE

PFP:00000

Explanation of General Maintenance

NLS0004I

General maintenance includes those items which should be checked during the normal day-to-day operation of the vehicle. They are essential if the vehicle is to continue operating properly. The owners can perform checks and inspections themselves or have their NISSAN dealers do them.

OUTSIDE THE VEHICLE

The maintenance items listed here should be performed from time to time, unless otherwise specified.

Item		Reference page
Tires	Check the pressure with a gauge, including the spare, at least once a month and always prior to a long distance trips. Adjust to the specified pressure if necessary. Check carefully for damage, cuts or excessive wear.	—
Wheel nuts	When checking the tires, make sure no nuts are missing, and check for any loose nuts. Tighten if necessary.	—
Windshield	Clean the windshield on a regular basis. Check the windshield at least every six months for cracks or other damage. Repair as necessary.	—
Tire rotation	Tires should be rotated every 12,000 km (7,500 miles).	MA-25
Wheel alignment and balance	If the vehicle pulls to either side while driving on a straight and level road, or if you detect uneven or abnormal tire wear, there may be a need for wheel alignment. If the steering wheel or seat vibrates at normal highway speeds, wheel balancing may be needed.	MA-24 , FSU-5
Windshield wiper blades	Check for cracks or wear if they do not wipe properly.	—
Doors and engine hood	Check that all doors and the engine hood operate smoothly as well as the trunk lid and back hatch. Also make sure that all latches lock securely. Lubricate if necessary. Make sure that the secondary latch keeps the hood from opening when the primary latch is released. When driving in areas using road salt or other corrosive materials, check lubrication frequently.	MA-29
Lamps	Make sure that the headlamps, stop lamps, tail lamps, turn signal lamps, and other lamps are all operating properly and installed securely. Also check headlamp aim. Clean the headlamps on a regular basis.	—

INSIDE THE VEHICLE

The maintenance items listed here should be checked on a regular basis, such as when performing periodic maintenance, cleaning the vehicle, etc.

Item		Reference page
Warning lamps and chimes	Make sure that all warning lamps and chimes are operating properly.	—
Windshield wiper and washer	Check that the wipers and washer operate properly and that the wipers do not streak.	—
Windshield defroster	Check that the air comes out of the defroster outlets properly and in sufficient quantity when operating the heater or air conditioner.	—
Steering wheel	Check that it has the specified play. Be sure to check for changes in the steering condition, such as excessive play, hard steering or strange noises. Free play: Less than 35 mm (1.37 in)	—
Seats	Check seat position controls such as seat adjusters, seatback recliner, etc. to make sure they operate smoothly and that all latches lock securely in every position. Check that the head restraints move up and down smoothly and that the locks (if equipped) hold securely in all latched positions. Check that the latches lock securely for folding-down rear seatbacks.	—
Seat belts	Check that all parts of the seat belt system (e.g. buckles, anchors, adjusters and retractors) operate properly and smoothly, and are installed securely. Check the belt webbing for cuts, fraying, wear or damage.	MA-29
Accelerator pedal	Check the pedal for smooth operation and make sure the pedal does not catch or require uneven effort. Keep the floor mats away from the pedal.	—
Brakes	Check that the brake does not pull the vehicle to one side when applied.	—

GENERAL MAINTENANCE

Item		Reference page
Brake pedal and booster	Check the pedal for smooth operation and make sure it has the proper distance under it when depressed fully. Check the brake booster function. Be sure to keep the floor mats away from the pedal.	BR-6 , BR-20
Parking brake	Check that the pedal has the proper travel and make sure that the vehicle is held securely on a fairly steep hill when only the parking brake is applied.	PB-2
CVT P (Park) position mechanism	On a fairly steep hill check that the vehicle is held securely with the selector lever in the P (Park) position without applying any brakes.	—

UNDER THE HOOD AND VEHICLE

The maintenance items listed here should be checked periodically (e.g. each time you check the engine oil or refuel).

Item		Reference page
Windshield washer fluid	Check that there is adequate fluid in the tank.	—
Engine coolant level	Check the coolant level when the engine is cold.	MA-14
Radiator and hoses	Check the front of the radiator and clean off any dirt, insects, leaves, etc., that may have accumulated. Make sure the hoses have no cracks, deformation, deterioration or loose connections.	—
Brake fluid level	Make sure that the brake fluid level is between the “MAX” and “MIN” lines on the reservoir.	MA-26
Battery	Check the fluid level in each cell. It should be between the “MAX” and “MIN” lines. Vehicles operated in high temperatures or under severe conditions require frequent checks of the battery fluid level.	—
Engine drive belts	Make sure that no belt is frayed, worn, cracked or oily.	MA-12
Engine oil level	Check the level on the oil level gauge after parking the vehicle on a level spot and turning off the engine.	MA-17
Power steering fluid level and lines	Check the level on the dipstick with the engine off. Check the lines for improper attachment, leaks, cracks, etc.	MA-27
Exhaust system	Make sure there are no loose supports, cracks or holes. If the sound of the exhaust seems unusual or there is a smell of exhaust fumes, immediately locate the trouble and correct it.	MA-21
Underbody	The underbody is frequently exposed to corrosive substances such as those used on icy roads or to control dust. It is very important to remove these substances, otherwise rust will form on the floor pan, frame, fuel lines and around the exhaust system. At the end of winter, the underbody should be thoroughly flushed with plain water, being careful to clean those areas where mud and dirt can easily accumulate.	—
Fluid leaks	Check under the vehicle for fuel, oil, water or other fluid leaks after the vehicle has been parked for a while. Water dripping from the air conditioner after use is normal. If you should notice any leaks or gasoline fumes are evident, check for the cause and correct it immediately.	—

PERIODIC MAINTENANCE

PERIODIC MAINTENANCE

PFP:00026

Introduction of Periodic Maintenance

NLS0004J

Two different maintenance schedules are provided, and should be used, depending upon the conditions in which the vehicle is mainly operated. **After 60,000 miles (96,000 km) or 48 months, continue the periodic maintenance at the same mileage/time intervals.**

Schedule 1	Follow Periodic Maintenance Schedule 1 if the driving habits frequently include one or more of the following driving conditions: <ul style="list-style-type: none"> ● Repeated short trips of less than 5 miles (8 km). ● Repeated short trips of less than 10 miles (16 km) with outside temperatures remaining below freezing. ● Operating in hot weather in stop-and-go "rush hour" traffic. ● Extensive idling and/or low speed driving for long distances, such as police, taxi or door-to-door delivery use. ● Driving in dusty conditions. ● Driving on rough, muddy, or salt spread roads. ● Towing a trailer, using a camper or a car-top carrier. 	Emission Control System Maintenance	MA-7
		Chassis and Body Maintenance	MA-8
Schedule 2	Follow Periodic Maintenance Schedule 2 if none of driving conditions shown in Schedule 1 apply to the driving habits.	Emission Control System Maintenance	MA-8
		Chassis and Body Maintenance	MA-9

PERIODIC MAINTENANCE

Schedule 1 EMISSION CONTROL SYSTEM MAINTENANCE

NLS0004K

Abbreviations: R = Replace. I = Inspect. Correct or replace if necessary. []: At the mileage intervals only

MAINTENANCE OPERATION		MAINTENANCE INTERVAL								Reference Section - Page or - Content Title
Perform at number of miles, kilometers or months, whichever comes first.	Miles x 1,000 (km x 1,000) Months	3.75 (6) 3	7.50 (12) 6	11.25 (18) 9	15 (24) 12	18.75 (30) 15	22.5 (36) 18	26.25 (42) 21	30 (48) 24	
Drive belts	NOTE (1)									MA-12
Air cleaner filter	NOTE (2)								[R]	MA-16
EVAP vapor lines									I*	MA-20
Fuel lines									I*	MA-16
Fuel filter	NOTE (3)									-
Engine coolant	NOTE (4)									MA-14
Engine oil		R	R	R	R	R	R	R	R	MA-17
Engine oil filter (Use part No. 15208 31U00 or 15208 65F00 or equivalent.)		R	R	R	R	R	R	R	R	MA-18
Spark plugs (PLATINUM-TIPPED type)		Replace every 105,000 miles (169,000 km).								MA-19
Intake & exhaust valve clearance*	NOTE (5)									EM-88. "Valve Clearance"

MAINTENANCE OPERATION		MAINTENANCE INTERVAL								Reference Section - Page or - Content Title
Perform at number of miles, kilometers or months, whichever comes first.	Miles x 1,000 (km x 1,000) Months	33.75 (54) 27	37.5 (60) 30	41.25 (66) 33	45 (72) 36	48.75 (78) 39	52.5 (84) 42	56.25 (90) 45	60 (96) 48	
Drive belts	NOTE (1)								I*	MA-12
Air cleaner filter	NOTE (2)								[R]	MA-16
EVAP vapor lines									I*	MA-20
Fuel lines									I*	MA-16
Fuel filter	NOTE (3)									-
Engine coolant	NOTE (4)								R*	MA-14
Engine oil		R	R	R	R	R	R	R	R	MA-17
Engine oil filter (Use part No. 15208 31U00 or 15208 65F00 or equivalent.)		R	R	R	R	R	R	R	R	MA-18
Spark plugs (PLATINUM-TIPPED type)		Replace every 105,000 miles (169,000 km).								MA-19
Intake & exhaust valve clearance*	NOTE (5)									EM-88. "Valve Clearance"

NOTE:

- (1) After 60,000 miles (96,000 km) or 48 months, inspect every 15,000 miles (24,000 km) or 12 months. Replace the drive belts if found damaged.
- (2) If operating mainly in dusty conditions, more frequent maintenance may be required.
- (3) Maintenance-free item. For service procedures, refer to FL section.
- (4) After 60,000 miles (96,000 km) or 48 months, replace every 30,000 miles (48,000 km) or 24 months.
- (5) If valve noise increases, inspect valve clearance.

* Maintenance items and intervals with "*" are recommended by NISSAN for reliable vehicle operation. The owner need not perform such maintenance in order to maintain the emission warranty or manufacturer recall liability. Other maintenance items and intervals are required.

PERIODIC MAINTENANCE

CHASSIS AND BODY MAINTENANCE

Abbreviations: R = Replace. I = Inspect. Correct or replace if necessary.

MAINTENANCE OPERATION		MAINTENANCE INTERVAL								Reference Section - Page or - Content Title
Perform at number of miles, kilometers or months, whichever comes first.	Miles x 1,000 (km x 1,000) Months	3.75 (6) 3	7.50 (12) 6	11.25 (18) 9	15 (24) 12	18.75 (30) 15	22.5 (36) 18	26.25 (42) 21	30 (48) 24	
Brake lines & cables					I				I	MA-26
Brake pads & rotors			I		I		I		I	MA-26
CVT fluid	NOTE (1)				I				I	MA-21, MA-22
Transfer oil & differential gear oil	NOTE (2)				I				I	MA-22, MA-23
Steering gear & linkage, axle & suspension parts			I		I		I		I	MA-27, MA-28
Tire rotation	NOTE (3)									MA-4, MA-25
Drive shaft boots and propeller shaft (AWD models)			I		I		I		I	MA-28, MA-23
Exhaust system			I		I		I		I	MA-21
In-cabin microfilter					R				R	ATC-117

MAINTENANCE OPERATION		MAINTENANCE INTERVAL								Reference Section - Page or - Content Title
Perform at number of miles, kilometers or months, whichever comes first.	Miles x 1,000 (km x 1,000) Months	33.75 (54) 27	37.5 (60) 30	41.25 (66) 33	45 (72) 36	48.75 (78) 39	52.5 (84) 42	56.25 (90) 45	60 (96) 48	
Brake lines & cables					I				I	MA-26
Brake pads & rotors			I		I		I		I	MA-26
CVT fluid	NOTE (1)				I				I	MA-21, MA-22
Transfer oil & differential gear oil	NOTE (2)				I				I	MA-22, MA-23
Steering gear & linkage, axle & suspension parts			I		I		I		I	MA-27, MA-28
Tire rotation	NOTE (3)									MA-4, MA-25
Drive shaft boots and propeller shaft (AWD models)			I		I		I		I	MA-28, MA-23
Exhaust system			I		I		I		I	MA-21
In-cabin microfilter					R				R	ATC-117

NOTE:

(1) If towing a trailer, using a camper or a car-top carrier, or driving on rough or muddy roads, inspect CVT fluid deterioration with CONSULT-II every 60,000 miles (96,000 km), then change CVT fluid NS-2 if necessary. (Refer to [CVT-64, "Check CVT Fluid Deterioration Date"](#) .) And if CONSULT-II is not available, change (not just inspect) CVT fluid NS-2 every 60,000 miles (96,000 km). **Using transmission fluid other than Genuine Nissan CVT Fluid NS-2 will damage the CVT, which is not covered by the NISSAN new vehicle limited warranty.**

(2) If towing a trailer, using a camper or a car-top carrier, or driving on rough or muddy roads, change (not just inspect) oil at every 30,000 miles (48,000) or 24 months.

(3) Refer to "Tire rotation" under the "GENERAL MAINTENANCE" heading earlier in this section.

Schedule 2 EMISSION CONTROL SYSTEM MAINTENANCE

NLS0004L

Abbreviations: R = Replace. I = Inspect. Correct or replace if necessary. []: At the mileage intervals only

MAINTENANCE OPERATION		MAINTENANCE INTERVAL								Reference Section - Page or - Content Title
Perform at number of miles, kilometers or months, whichever comes first.	Miles x 1,000 (km x 1,000) Months	7.5 (12) 6	15 (24) 12	22.5 (36) 18	30 (48) 24	37.5 (60) 30	45 (72) 36	52.5 (84) 42	60 (96) 48	
Drive belts	NOTE (1)								I*	MA-12
Air cleaner filter					[R]				[R]	MA-16

PERIODIC MAINTENANCE

MAINTENANCE OPERATION		MAINTENANCE INTERVAL								Reference Section - Page or - Content Title
Perform at number of miles, kilometers or months, whichever comes first.	Miles x 1,000 (km x 1,000) Months	7.5 (12) 6	15 (24) 12	22.5 (36) 18	30 (48) 24	37.5 (60) 30	45 (72) 36	52.5 (84) 42	60 (96) 48	
EVAP vapor lines					I*				I*	MA-20
Fuel lines					I*				I*	MA-16
Fuel filter	NOTE (2)									-
Engine coolant	NOTE (3)								R*	MA-14
Engine oil		R	R	R	R	R	R	R	R	MA-17
Engine oil filter (Use part No. 15208 31U00 or 15208 65F00 or equivalent.)		R	R	R	R	R	R	R	R	MA-18
Spark plugs (PLATINUM-TIPPED type)		Replace every 105,000 miles (169,000 km).								MA-19
Intake & exhaust valve clearance*	NOTE (4)									EM-88, "Valve Clearance"

NOTE:

- (1) After 60,000 miles (96,000 km) or 48 months, inspect every 15,000 miles (24,000 km) or 12 months. Replace the drive belts if found damaged.
 - (2) Maintenance-free item. For service procedures, refer to FL section.
 - (3) After 60,000 miles (96,000 km) or 48 months, replace every 30,000 miles (48,000 km) or 24 months.
 - (4) If valve noise increases, inspect valve clearance.
- * Maintenance items and intervals with "*" are recommended by NISSAN for reliable vehicle operation. The owner need not perform such maintenance in order to maintain the emission warranty or manufacturer recall liability. Other maintenance items and intervals are required

CHASSIS AND BODY MAINTENANCE

Abbreviations: R = Replace. I = Inspect. Correct or replace if necessary.

MAINTENANCE OPERATION		MAINTENANCE INTERVAL								Reference Section - Page or - Content Title
Perform at number of miles, kilometers or months, whichever comes first.	Miles x 1,000 (km x 1,000) Months	7.5 (12) 6	15 (24) 12	22.5 (36) 18	30 (48) 24	37.5 (60) 30	45 (72) 36	52.5 (84) 42	60 (96) 48	
Brake lines & cables			I		I		I		I	MA-26
Brake pads & rotors			I		I		I		I	MA-26
CVT fluid	NOTE (1)		I		I		I		I	MA-21
Transfer oil & differential gear oil			I		I		I		I	MA-22, MA-23
Steering gear & linkage, axle & suspension parts					I				I	MA-27, MA-28
Tire rotation	NOTE (2)									MA-4, MA-25
Drive shaft boots and propeller shaft (AWD models)			I		I		I		I	MA-28, MA-23
Exhaust system					I				I	MA-21
In-cabin microfilter			R		R		R		R	ATC-117

NOTE:

- (1) Using transmission fluid other than Genuine Nissan CVT Fluid NS-2 will damage the CVT, which is not covered by the NISSAN new vehicle limited warranty.
- (2) Refer to "Tire rotation" under the "GENERAL MAINTENANCE" heading earlier in this section.

RECOMMENDED FLUIDS AND LUBRICANTS

RECOMMENDED FLUIDS AND LUBRICANTS

PFP:00000

Fluids and Lubricants

NLS0004M

		Capacity (Approximate)			Recommended Fluids/Lubricants
		US measure	Imp measure	Liter	
Engine oil Drain and refill	With oil filter change	4-1/4 qt	3-1/2 qt	4.0	<ul style="list-style-type: none"> ● API Certification Mark*1 ● API grade SG/SH, Energy Conserving I & II or API grade SJ or SL, Energy Conserving*1 ● ILSAC grade GF-I, GF-II & GF-III *1
	Without oil filter change	3-7/8 qt	3-1/4 qt	3.7	
Dry engine (Overhaul)		5-1/4 qt	4-3/8 qt	5.0	
Cooling system	With reservoir tank	10-1/8 qt	8-1/2 qt	9.6	Genuine NISSAN Long Life Antifreeze/Coolant or equivalent
	Reservoir tank	7/8 qt	3/4 qt	0.8	
CVT fluid		10-6/8 qt	9 qt	10.2	Genuine NISSAN CVT Fluid NS-2 *2
Differential gear oil		1-1/8 pt	1 pt	0.55	API GL-5, Viscosity SAE 80 W-90 *3
Transfer oil		5/8 pt	1/2 pt	0.31	API GL-5, Viscosity SAE 80 W-90
Power steering fluid (PSF)		1-1/8 qt	7/8 qt	1.0	Genuine NISSAN PSF or equivalent*4
Brake fluid		—	—	—	Genuine NISSAN Super Heavy Duty Brake Fluid*5 or equivalent DOT 3 (US FMVSS No. 116)
Multi-purpose grease		—	—	—	NLGI No. 2 (Lithium soap base)
Windshield washer fluid		—	—	—	Genuine NISSAN Windshield Washer Concentrate Cleaner & Antifreeze or equivalent
Fuel recommendation		—	—	—	Refer to GI-6, "Precautions for Fuel (Unleaded Premium Gasoline Recommended)"

*1: For further details, see "SAE Viscosity Number".

***2: Using transmission fluid other than Genuine NISSAN CVT Fluid NS-2 will damage the CVT, which is not covered by the NISSAN new vehicle limited warranty.**

*3: For hot climates, viscosity SAE 90 is suitable for ambient temperatures above 0°C (32°F).

*4: For Canada, NISSAN Automatic Transmission Fluid (ATF), DEXRON™ III/ MERCON™ , or equivalent ATF may also be used.

*5: Available in mainland U.S.A. through your NISSAN dealer.

RECOMMENDED FLUIDS AND LUBRICANTS

SAE Viscosity Number GASOLINE ENGINE OIL

NLS0004N

SAE 5W-30 viscosity oil is preferred for all temperatures. SAE 10W-30 and 10W-40 viscosity oil may be used if the ambient temperature is above -18°C(0°F)

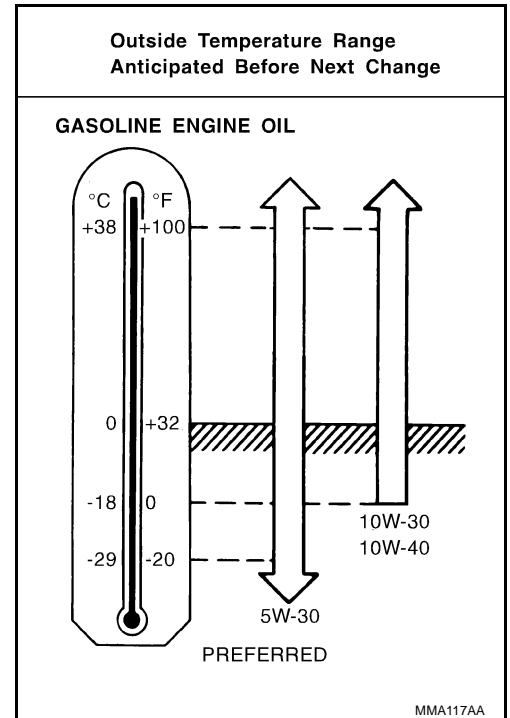

Anti-Freeze Coolant Mixture Ratio

NLS0004O

The engine cooling system is filled at the factory with a high-quality, year-round, anti-freeze coolant solution. The anti-freeze solution contains rust and corrosion inhibitors. Therefore, additional cooling system additives are not necessary.

CAUTION:

When adding or replacing coolant, be sure to use only Genuine Nissan Long Life Antifreeze/Coolant or equivalent with the proper mixture ratio of 50% anti-freeze and 50% demineralized water/distilled water.

Other types of coolant solutions may damage your cooling system.

Outside temperature down to		Anti-freeze	Demineralized water or distilled water
°C	°F		
-35	-30	50%	50%

SMA947CA

ENGINE MAINTENANCE

ENGINE MAINTENANCE

PFP:00000

Checking Drive Belts

NLS0004P

WARNING:

Be sure to perform when the engine is stopped.

1. Inspect belts for cracks, fraying, wear and oil. If necessary, replace.
2. Inspect drive belt deflection or tension at a point on belt midway between pulleys.
 - Inspection should be done only when engine is cold, or over 30 minutes after engine is stopped.
 - Measure belt tension with tension gauge (Commercial service tool: BT3373-F or equivalent) at points marked ▼ shown in the figure.
 - When measuring deflection, apply 98 N (10 kg, 22 lb) at the ▼ marked point.
 - Adjust if belt deflection exceeds the limit or if belt tension is not within specifications.

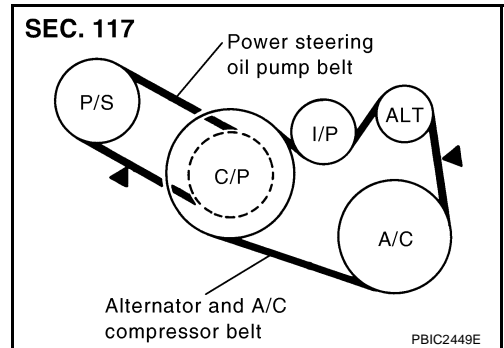

CAUTION:

- When checking belt deflection or tension immediately after installation, first adjust it to the specified value. Then, after turning the crankshaft two turns or more, re-adjust to the specified value to avoid variation in deflection between pulleys.
- Release the tension by loosening lock nut and turning adjusting bolt when adjusting the belt. Tighten once the lock nut at 4.9 N·m(0.50 Kg·m,43 in·lb). Then, adjust the belt tension by loosening lock nut between 45° and 90°.

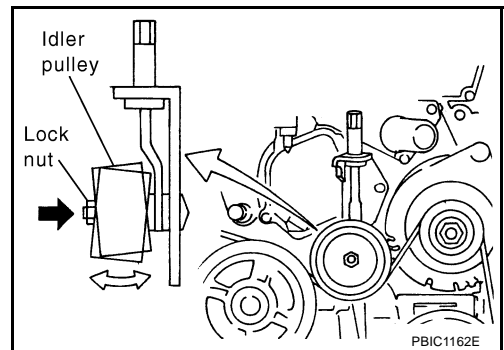

Belt Deflection and Tension

	Deflection adjustment		Unit: mm (in)	Tension adjustment*		Unit: N (kg, lb)
	Used belt			Used belt		
	Limit	After adjustment	New belt	Limit	After adjustment	New belt
Alternator and A/C compressor	7 (0.28)	4.2 - 4.6 (0.17 - 0.18)	3.7 - 4.1 (0.15 - 0.16)	294 (30, 66)	730 - 818 (74.5 - 83.5, 164 - 184)	838 - 926 (85.5 - 94.5, 188 - 208)
Power steering oil pump	11 (0.43)	7.3 - 8 (0.29 - 0.30)	6.5 - 7.2 (0.26 - 0.28)	196 (20, 44)	495 - 583 (50.5 - 59.5, 111 - 131)	603 - 691 (61.5 - 70.5, 135.6 - 155.4)
Applied pushing force	98 N (10 Kg, 22 lb)			—		

*: If belt tension gauge cannot be installed at check points shown, check drive belt tension at different location on the belt.

Tension Adjustment

NLS0004Q

Portion	Belt tightening method for adjustment
Power steering oil pump belt	Adjusting bolt on power steering oil pump
Alternator and air conditioner compressor belt	Adjusting bolt on idler pulley

CAUTION:

- When belt is replaced with a new one, adjust it to value for “New belt” to accommodate for insufficient adaptability with pulley grooves.

ENGINE MAINTENANCE

- When deflection or tension of belt being used exceeds “Limit”, adjust it to value for “After adjustment”.
- When checking belt deflection or tension immediately after installation, first adjust it to the specified value. Then, after turning the crankshaft two turns or more, re-adjust to the specified value to avoid variation in deflection between pulleys.
- Release the tension by loosening lock nut and turning adjusting nut when adjusting the belt. Tighten once the lock nut at 4.9 N·m (0.50 kg·m, 43 in·lb). Then, adjust the belt tension by loosening lock nut between 45° and 90°.
- When installing belt, make sure that it is correctly engaged with pulley groove.
- Keep engine oil, working fluid and engine coolant away from belt.
- Do not twist or bend belt excessively.

ALTERNATOR AND A/C COMPRESSOR BELT

1. Remove splash guard (RH).
2. Loosen idler pulley lock nut (A).
3. Release the belt tension on idler pulley by turning adjusting nut (B).
4. Tighten lock nut (A). Then, loosen lock nut between 45° and 90°.

 : 4.9 N·m (0.50 kg·m, 43 in·lb)

5. Adjust tension by turning adjusting nut (B).
 - For the specified belt tension, refer to [MA-12, "Checking Drive Belts"](#).
6. Tighten lock nut (A).

 : 34.8 N·m (3.5 kg·m, 26 ft·lb)

7. Tighten adjusting nut (B).

 : 5.4 N·m (0.55 kg·m, 48 in·lb)

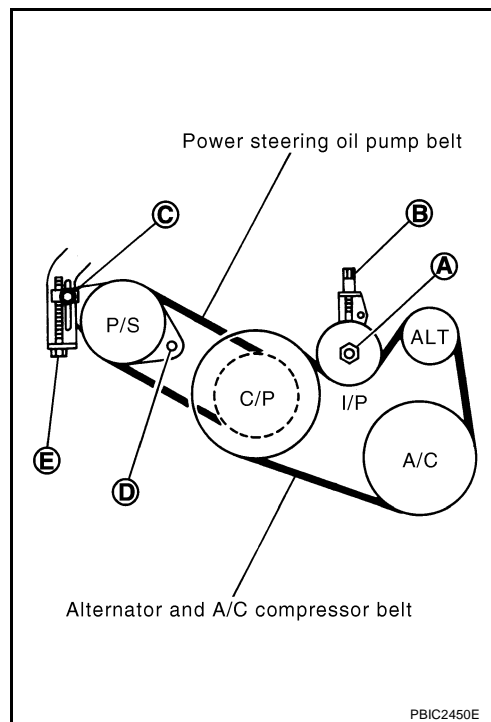

POWER STEERING OIL PUMP BELT

1. Remove splash guard (RH).
2. Loosen lock bolt (C).
3. Loosen power steering oil pump mounting bolt (D).
 - Bolt head (D) is engine rear side.
4. Adjust tension by turning adjusting bolt (E).
 - For specified belt tension, refer to [MA-12, "Checking Drive Belts"](#).

NOTE:

Adjusting bolt (E) is loosened with counterclockwise rotation.

5. Tighten lock bolt (C).

 : 28.0 N·m (2.9 kg·m, 21 ft·lb)

6. Tighten power steering oil pump mounting bolt (D).

ENGINE MAINTENANCE

 : 43.2 N·m (4.4 kg-m, 32 ft-lb)

Changing Engine Coolant

NLS0004R

WARNING:

- To avoid being scalded, never change engine coolant when the engine is hot.
- Wrap a thick cloth around radiator cap and carefully remove radiator cap. First, turn radiator cap a quarter of a turn to release built-up pressure. Then turn radiator cap all the way.

CAUTION:

Be careful not to allow engine coolant to contact drive belts.

DRAINING ENGINE COOLANT

1. Remove radiator drain hole cap on undercover.
2. Open radiator drain plug at the bottom of radiator, and then remove radiator cap.

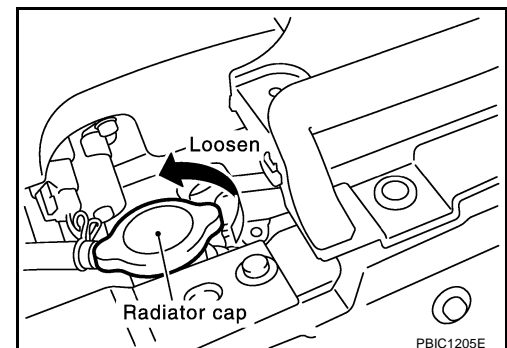
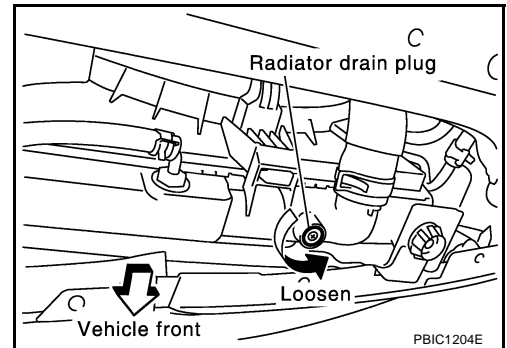

When draining all of engine coolant in the system, open water drain plugs on cylinder block. Refer to [EM-115, "DISASSEMBLY"](#) .

3. Remove reservoir tank as necessary, and drain engine coolant and clean reservoir tank before installing.
4. Check drained engine coolant for contaminants such as rust, corrosion or discoloration. If contaminated, flush the engine cooling system. Refer to [MA-16, "FLUSHING COOLING SYSTEM"](#) .

REFILLING ENGINE COOLANT

NOTE:

When engine coolant is drained from radiator only, step 3, 4 and 6 are unnecessary.

1. Install reservoir tank if removed, and radiator drain plug.

CAUTION:

Be sure to clean drain plug and install with new O-ring.

Radiator drain plug:

 : 0.78 - 1.56 N·m (0.08 - 0.15 kg-m, 7 - 13 in-lb)

If water drain plug on cylinder block are removed, close and tighten them. Refer to [EM-120, "ASSEMBLY"](#) .

2. Make sure that each hose clamp has been firmly tightened.
3. Remove air duct assembly. Refer to [EM-16, "AIR CLEANER AND AIR DUCT"](#) .

ENGINE MAINTENANCE

4. Disconnect heater hose (right side of vehicle) at the position in the figure.

- Enhance heater hose as high as possible.

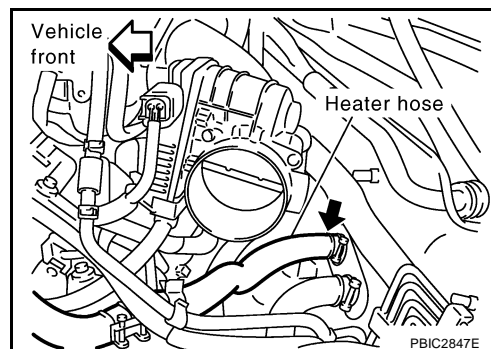

5. Fill radiator, and reservoir tank if removed, to specified level.

- **Pour engine coolant through engine coolant filler neck slowly of less than 2 ℓ (2-1/8 US qt, 1-3/4 Imp qt) a minute to allow air in system to escape.**
- **Use Genuine Nissan Long Life Antifreeze/Coolant or equivalent mixed with water (distilled or demineralized). Refer to [MA-10, "RECOMMENDED FLUIDS AND LUBRICANTS"](#).**

**Engine coolant capacity
(With reservoir tank at "MAX" level)**

: Approximately 9.6 ℓ (10-1/8 US qt, 8-1/2 Imp qt)

**Reservoir tank engine coolant capacity
(At "MAX" level)**

: 0.8 ℓ (7/8 US qt, 3/4 Imp qt)

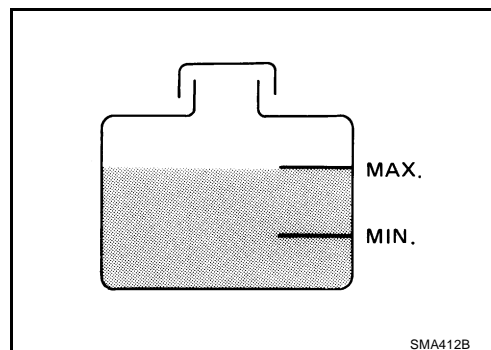
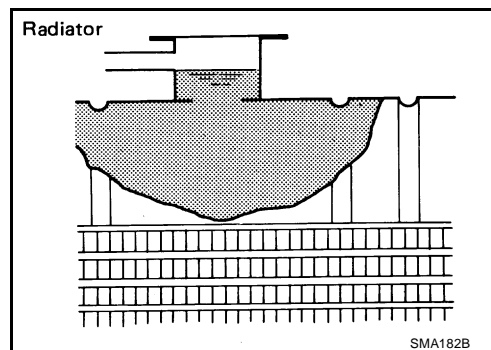

- When engine coolant overflows disconnected heater hose, connect heater hose, and continue filling the engine coolant, if heater hose is disconnected.

6. Install air duct assembly. Refer to [EM-16, "AIR CLEANER AND AIR DUCT"](#).

7. Install radiator cap.

8. Warm up until opening thermostat. Standard for warming-up time is approximately 10 minutes at 3000 rpm.

- Make sure thermostat opening condition by touching radiator hose (lower) to see a flow of warm water.

CAUTION:

Watch water temperature gauge so as not to overheat engine.

9. Stop the engine and cool down to less than approximately 50°C (122°F).

- Cool down using fan to reduce the time.
- If necessary, refill radiator up to filler neck with engine coolant.

10. Refill reservoir tank to "MAX" level line with engine coolant.

11. Repeat steps 5 through 9 two or more times with radiator cap installed until engine coolant level no longer drops.

12. Check cooling system for leaks with engine running.

13. Warm up the engine, and check for sound of engine coolant flow while running engine from idle up to 3,000 rpm with heater temperature controller set at several position between "COOL" and "WARM".

- Sound may be noticeable at heater unit.

ENGINE MAINTENANCE

- Repeat step 13 three times.
- If sound is heard, bleed air from cooling system by repeating step 5 through 9 until engine coolant level no longer drops.

FLUSHING COOLING SYSTEM

NOTE:

When engine coolant is drained from radiator only, step 2, 3 and 5 are unnecessary.

- Install reservoir tank if removed, and radiator drain plug.

Radiator drain plug:

 : 0.78 - 1.56 N·m (0.08 - 0.15 kg·m, 7 - 13 in·lb)

If water drain plug on cylinder block are removed, close and tighten them. Refer to [EM-120, "ASSEMBLY"](#).

- Remove air duct assembly. Refer to [EM-16, "AIR CLEANER AND AIR DUCT"](#).
- Disconnect heater hose (right side of vehicle) at the position in the figure.
 - Enhance heater hose as high as possible.

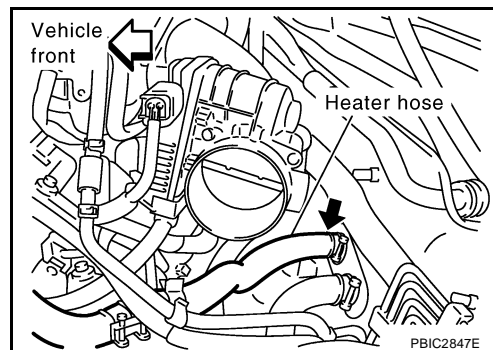

- Fill radiator and reservoir tank with water and install radiator cap.
 - When engine coolant overflows disconnected heater hose, connect heater hose, and continue filling the engine coolant, if heater hose is disconnected.
- Install air duct assembly. Refer to [EM-16, "AIR CLEANER AND AIR DUCT"](#).
- Run the engine and warm it up to normal operating temperature.
- Rev the engine two or three times under no-load.
- Stop the engine and wait until it cools down.
- Drain water from the system. Refer to [MA-14, "DRAINING ENGINE COOLANT"](#).
- Repeat steps 1 through 9 until clear water begins to drain from radiator.

Checking Fuel Lines

Inspect fuel lines, fuel filler cap and fuel tank for improper attachment, leaks, cracks, damage, loose connections, chafing or deterioration.

If necessary, repair or replace damaged parts.

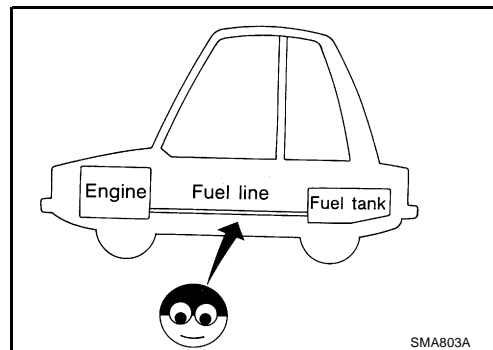

Changing Air Cleaner Filter VISCIOUS PAPER TYPE

The viscous paper type filter does not need cleaning between replacement intervals. Refer to [MA-6, "PERIODIC MAINTENANCE"](#).

- Unhook air cleaner case (lower) side clips and lift up air cleaner case (upper).

ENGINE MAINTENANCE

- Remove air cleaner filter.

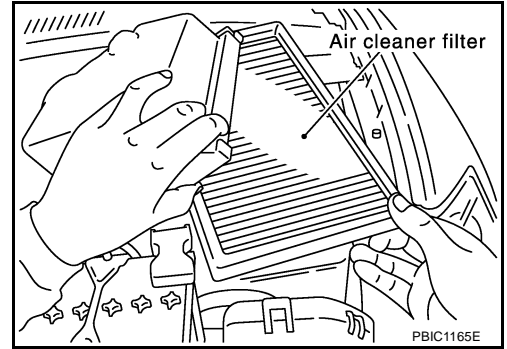

NLS0004U

Changing Engine Oil

WARNING:

- Be careful not to burn yourself, as engine oil may be hot.
- Prolonged and repeated contact with used engine oil may cause skin cancer; try to avoid direct skin contact with used engine oil. If skin contact is made, wash thoroughly with soap or hand cleaner as soon as possible.

- Warm up engine, put vehicle horizontally and check for engine oil leakage from engine components. Refer to [LU-6, "ENGINE OIL LEAKAGE"](#).
- Stop engine and wait for 10 minutes.
- Loosen oil filler cap, and then remove drain plug.
- Drain engine oil.
- Install drain plug with new washer. Refer to [EM-29, "OIL PAN AND OIL STRAINER"](#).

CAUTION:

Be sure to clean drain plug and install with new washer.

Oil pan drain plug:

 :34.3 N·m (3.5 kg·m, 25 ft·lb)

- Refill with new engine oil.
Engine oil specification and viscosity:
Refer to [MA-10, "RECOMMENDED FLUIDS AND LUBRICANTS"](#).

Engine oil capacity (Approximate):

Unit: ℓ (US qt, Imp qt)

Drain and refill	With oil filter change	4.0 (4-1/4, 3-1/2)
	Without oil filter change	3.7 (3-7/8, 3-1/4)
Dry engine (Overhaul)		5.0 (5-1/4, 4-3/8)

CAUTION:

- When filling engine oil, do not pull out oil level gauge.
 - The refill capacity depends on the engine oil temperature and drain time. Use these specifications for reference only.
 - Always use oil level gauge to determine the proper amount of engine oil in engine.
- Warm up engine and check area around drain plug and oil filter for oil leakage.
 - Stop engine and wait for 10 minutes.

ENGINE MAINTENANCE

9. Check the engine oil level.

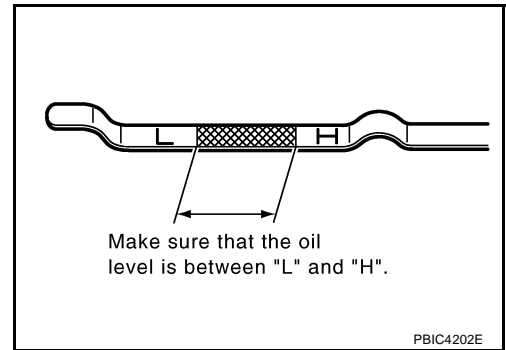

Changing Oil Filter REMOVAL

WARNING:

Be careful not to get burned when the engine and engine oil may be hot.

1. Remove splash guard (RH).
2. Using oil filter wrench [SST], remove oil filter.

CAUTION:

- Oil filter is provided with relief valve. Use genuine Nissan oil filter or equivalent.
- Be careful not to get burned when engine and engine oil may be hot.
- When removing, prepare a shop cloth to absorb any engine oil leakage or spillage.
- Do not allow engine oil to adhere to drive belts.
- Completely wipe off any engine oil that adheres to engine and vehicle.

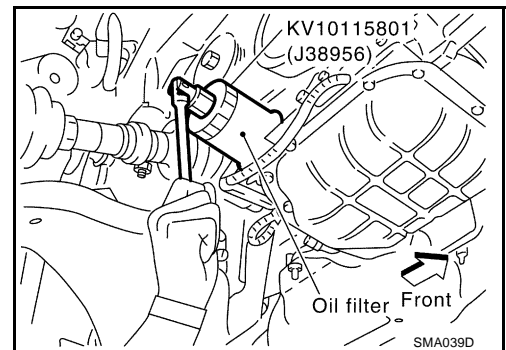

INSTALLATION

1. Remove foreign materials adhering to oil filter installation surface.
2. Apply engine oil to the oil seal contact surface of new oil filter.

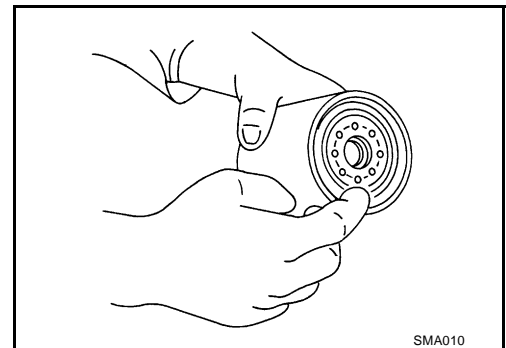

3. Screw oil filter manually until it touches the installation surface, then tighten it by 2/3 turn. Or tighten to specification.

Oil filter:

 : 17.6 N·m (1.8 kg·m, 13 ft·lb)

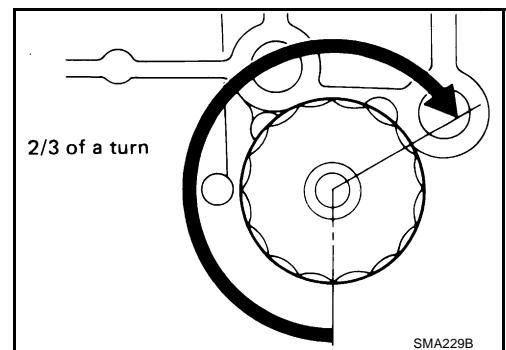

INSPECTION AFTER INSTALLATION

1. Check the engine oil level. Refer to [MA-17, "Changing Engine Oil"](#).
2. Start engine, and check there is no leak of engine oil.

ENGINE MAINTENANCE

3. Stop engine and wait for 10 minutes.
4. Check engine oil level and add engine oil. Refer to [MA-17, "Changing Engine Oil"](#) .

Changing Spark Plugs (Platinum-Tipped Type) REMOVAL

NLS0004W

1. Remove engine cover. Refer to [EM-18, "INTAKE MANIFOLD COLLECTOR"](#) .
2. Remove ignition coil. Refer to [EM-38, "IGNITION COIL"](#) .
3. Remove spark plug using spark plug wrench (commercial service tool).

CAUTION:

Do not drop or shock it.

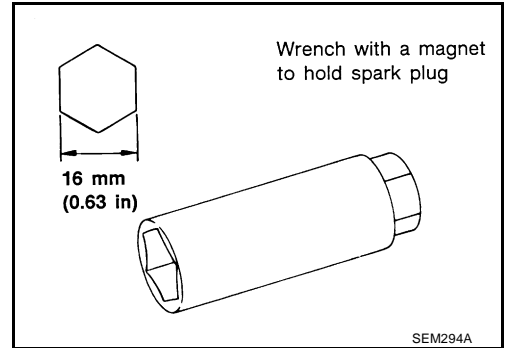

INSPECTION AFTER REMOVAL

Use standard type spark plug for normal condition.

Hot type spark plug is suitable when fouling occurs with standard type spark plug under conditions such as:

- Frequent engine starts
- Low ambient temperatures

Cold type spark plug is suitable when spark plug knock occurs with standard type spark plug under conditions such as:

- Extended highway driving
- Frequent high engine revolution

Make	NGK
Standard type	PLFR5A-11
Hot type	PLFR4A-11
Cold type	PLFR6A-11

Gap (Nominal) : 1.1 mm (0.043 in)

CAUTION:

- Do not drop or shock spark plug.
- Do not use wire brush for cleaning.
- If plug tip is covered with carbon, spark plug cleaner may be used.

Cleaner air pressure:

Less than 588 kPa (6 kg/cm² , 85 psi)

Cleaning time:

Less than 20 seconds

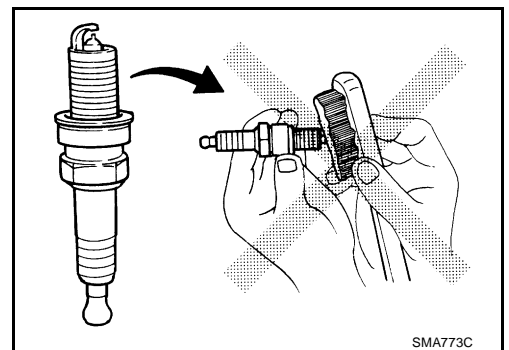

A
B
C
D
E
F
G
H
I
J
K

MA

M

ENGINE MAINTENANCE

- Checking and adjusting plug gap is not required between change intervals.

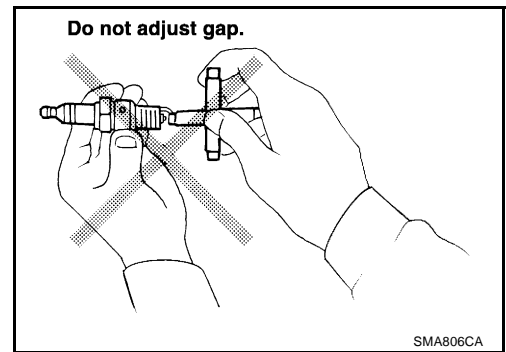

INSTALLATION

Install in the reverse order of removal.

 : 24.5 N·m (2.5 kg-m, 18 ft-lb)

Checking EVAP Vapor Lines

NLS0004X

1. Visually inspect EVAP vapor lines for improper attachment and for cracks, damage, loose connections, chafing and deterioration.
2. Inspect fuel tank filler cap vacuum relief valve for clogging, sticking, etc.
Refer to **EC-30, "EVAPORATIVE EMISSION SYSTEM"** .

CHASSIS AND BODY MAINTENANCE

PF0:00100

Checking Exhaust System

NLS0004Y

Check exhaust pipes, muffler and mounting for improper attachment, leaks, cracks, damage, chafing or deterioration.

- If anything is found, repair or replace damaged parts.

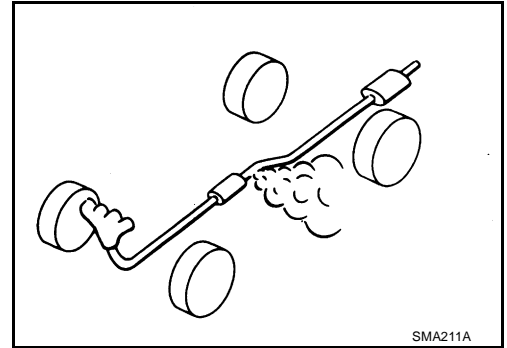

Checking CVT Fluid FLUID LEVEL CHECK

NLS0004Z

Fluid level should be checked with the fluid warmed up to 50 to 80°C (122 to 176°F). The fluid level check procedure is as follows:

1. Check for fluid leakage.
2. With the engine warmed up, drive the vehicle in an urban area. When ambient temperature is 20°C (68°F), it takes about 10 minutes for the transmission fluid to warm up to 50 - 80°C (122 - 176°F).
3. Park the vehicle on a level surface.
4. Apply parking brake firmly.
5. With engine at idle, while depressing brake pedal, move shift selector throughout the entire shift range.

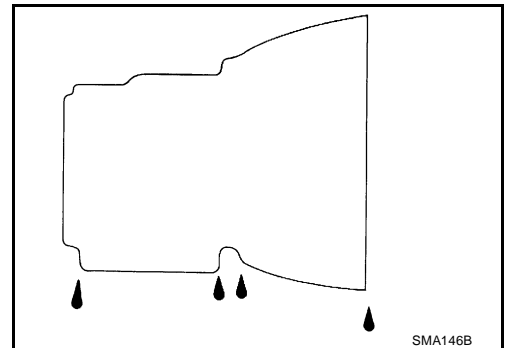

6. Pull out the CVT fluid level gauge from the CVT fluid charging pipe after pressing the tab on the CVT fluid level gauge to release the lock.

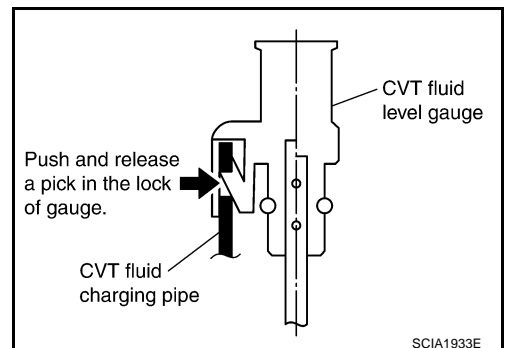

7. Wipe fluid off the CVT fluid level gauge and rotate the CVT fluid level gauge attached for 180° to securely insert the CVT fluid level gauge until it meets the end of the CVT fluid charging pipe.

CAUTION:

Always use paper towels to wipe fluid off the CVT fluid level gauge.

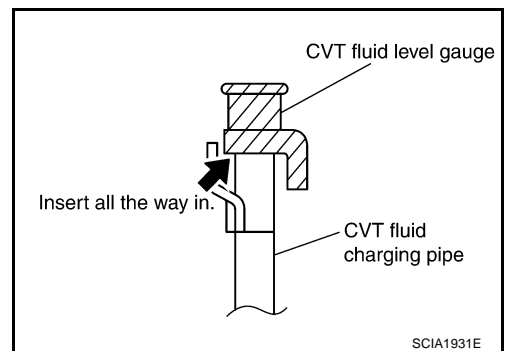

CHASSIS AND BODY MAINTENANCE

8. Place the selector lever in P or N and make sure the fluid level is within the specified range.

CAUTION:

- When CVT fluid level gauge reinstall, insert CVT fluid charging pipe until CVT fluid level gauge is locking surely.

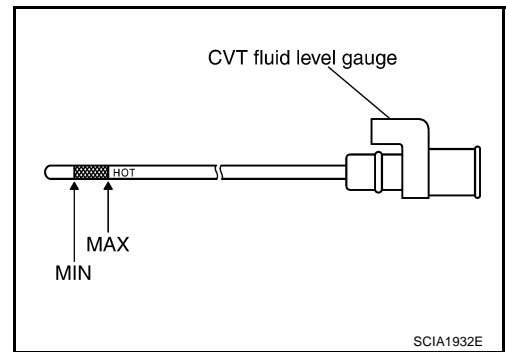

FLUID CONDITION CHECK

Fluid status	Conceivable Cause	Required Operation
Varnished (viscous varnish state)	Clutch, brake scorched	Replace the CVT fluid and check the CVT main unit and the vehicle for malfunctions (wire harnesses, cooler pipes, etc.)
Milky white or cloudy	Water in the fluid	Replace the CVT fluid and check for places where water is getting in.
Large amount of metal powder mixed in	Unusual wear of sliding parts within CVT	Replace the CVT fluid and check for improper operation of the CVT.

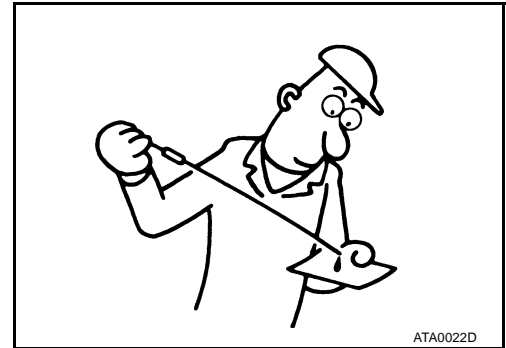

Changing CVT Fluid

NLS00050

1. Warm up CVT fluid by driving the vehicle for 10 minutes.
2. Drain CVT fluid from CVT fluid cooler hose (return side) and refill with new CVT fluid at CVT fluid charging pipe with the engine running at idle speed.
3. Refill until new CVT fluid comes out from CVT fluid cooler hose (return side). About 30 to 50% extra fluid will be required for this procedure.

Fluid capacity

Approx. 10.2 l (10-6/8 US qt, 9 Imp qt)

CAUTION:

Use Genuine Nissan CVT Fluid NS-2.

4. Check fluid level and condition.

Checking Transfer Oil

NLS00051

Check for oil leakage and oil level.

CAUTION:

Never start engine while checking oil level.

Filler plug:

 : 14.7 N·m (1.5 kg·m, 11 ft·lb)

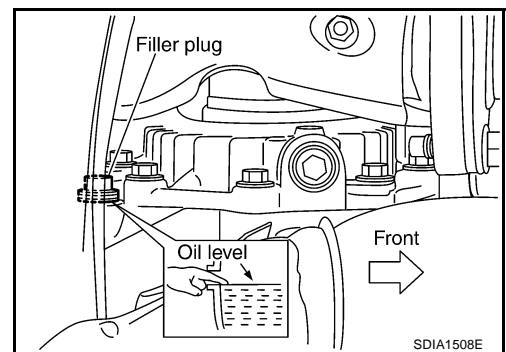

CHASSIS AND BODY MAINTENANCE

Changing Transfer Oil

NLS00052

CAUTION:

When draining oil, protect exhaust tube flange with cover.

1. Drain oil from drain plug and refill with new gear oil.
2. Check oil level.

CAUTION:

Carefully fill the oil. (Fill up for Approx. 3 minutes.)

Oil grade:

API GL-5

Viscosity:

Refer to [MA-10, "RECOMMENDED FLUIDS AND LUBRICANTS"](#)

Oil capacity:

: Approx. 0.31 ℓ (5/8 US pt, 1/2 Imp pt)

Drain plug:

 : 14.7 N·m (1.5 kg·m, 11 ft·lb)

Filler plug:

 : 14.7 N·m (1.5 kg·m, 11 ft·lb)

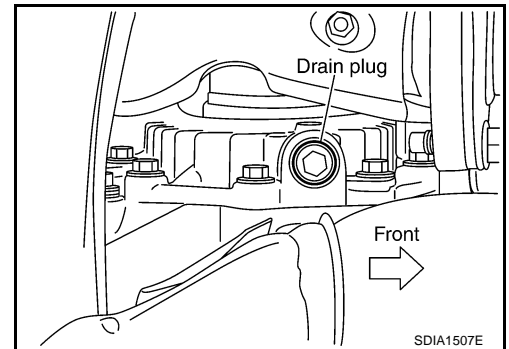

Checking Propeller Shaft

Check propeller shaft for damage, looseness or grease leakage.

Tightening torque:

Refer to [PR-4, "REAR PROPELLER SHAFT"](#)

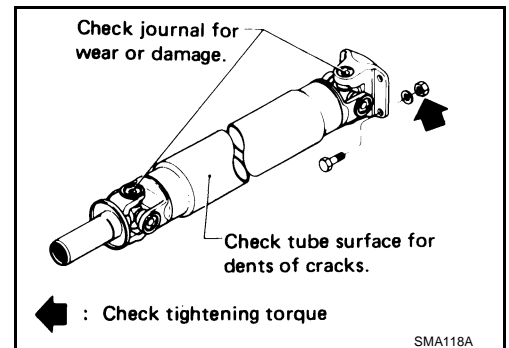

Checking Differential Gear Oil

1. Check for oil leakage. Refer to [RFD-8, "Checking Differential Gear Oil"](#).

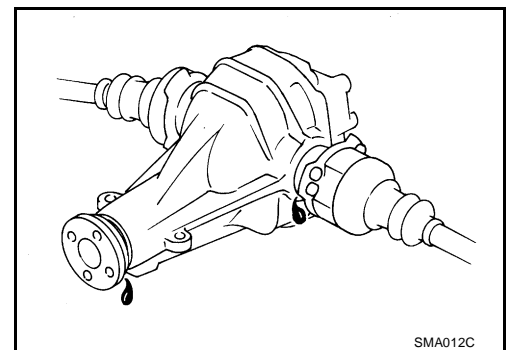

A
B
C
D
E
F
G
H
I
J
K
MA
M

CHASSIS AND BODY MAINTENANCE

Changing Differential Gear Oil

NLS00055

1. Drain oil from drain plug and refill with new gear oil. Refer to [RFD-8, "Changing Differential Gear Oil"](#).
2. Check oil level.

Oil grad and Viscosity:

Refer to [MA-10, "RECOMMENDED FLUIDS AND LUBRICANTS"](#).

Capacity:

0.55 l (1-1/8 US pt, 1 Imp pt)

Drain plug:

 : 34.5 N·m (3.5 kg·m, 25 ft·lb)

Filler plug:

 : 34.5 N·m (3.5 kg·m, 25 ft·lb)

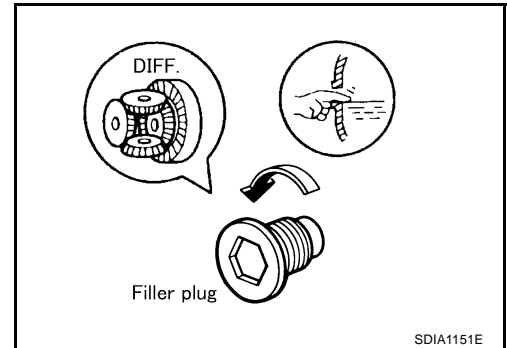

CAUTION:

Gaskets are not reusable. Never reuse them.

Balancing Wheels (Bonding Weight Type) REMOVAL

NLS00056

1. Remove inner and outer balance weights from the road wheel.

CAUTION:

Be careful not to scratch the road wheel during removal.

2. Using releasing agent, remove double-faced adhesive tape from the road wheel.

CAUTION:

- Be careful not to scratch the road wheel during removal.
- After removing double-faced adhesive tape, wipe clean traces of releasing agent from the road wheel.

WHEEL BALANCE ADJUSTMENT

- If a tire balance machine has adhesion balance weight mode settings and drive-in weight mode setting, select and adjust a drive-in weight mode suitable for road wheels.
1. Set road wheel on wheel balancer using the center hole as a guide. Start the tire balance machine.
 2. When inner and outer unbalance values are shown on the wheel balancer indicator, multiply outer unbalance value by 5/3 to determine balance weight that should be used. Select the outer balance weight with a value closest to the calculated value above and install it to the designated outer position of, or at the designated angle in relation to the road wheel.

CAUTION:

- Do not install the inner balance weight before installing the outer balance weight.
- Before installing the balance weight, be sure to clean the mating surface of the road wheel.

- a. Indicated unbalance value $\times 5/3 =$ balance weight to be installed
Calculation example:
 $23 \text{ g (0.81 oz)} \times 5/3 = 38.33 \text{ g (1.35 oz)} = 40 \text{ g (1.41 oz)}$ balance weight (closer to calculated balance weight value)

NOTE:

Note that balance weight value must be closer to the calculated balance weight value.

Example:

$37.4 = 35 \text{ g (1.23 oz)}$

$37.5 = 40 \text{ g (1.41 oz)}$

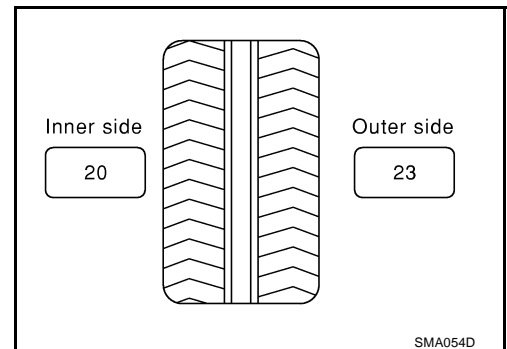

CHASSIS AND BODY MAINTENANCE

- b. Install balance weight in the position shown in the figure at left.
- c. When installing balance weight to road wheels, set it into the grooved area on the inner wall of the road wheel as shown in the figure so that the balance weight center is aligned with the wheel balancer indication position (angle).

CAUTION:

- Always use genuine Nissan adhesion balance weights.
- Balance weights are non-reusable; always replace with new ones.
- Do not install more than three sheets of balance weight.

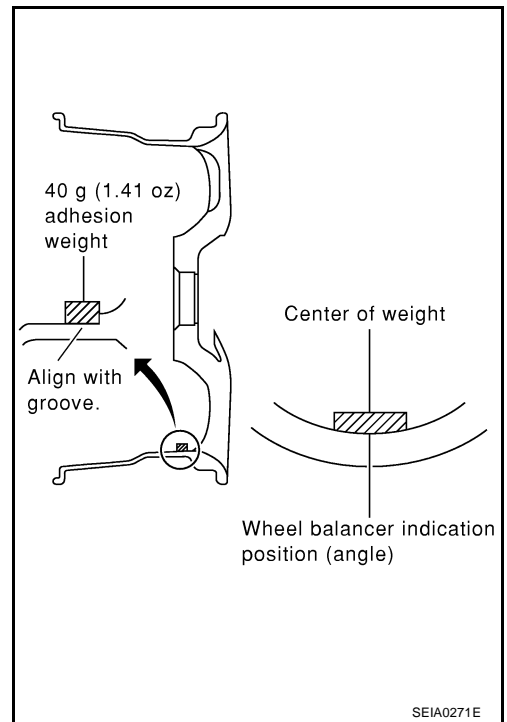

- d. If calculated balance weight value exceeds 50 g (1.76 oz), install two balance weight sheets in line with each other (as shown in the figure).

CAUTION:

Do not install one balance weight sheet on top of another.

3. Start wheel balancer again.
4. Install drive-in balance weight on inner side of road wheel in the wheel balancer indication position (angle).

CAUTION:

Do not install more than two balance weights.

5. Start wheel balancer. Make sure that inner and outer residual unbalance values are 5 g (0.17 oz) each or below.
6. If either residual unbalance value exceeds 5 g (0.17 oz), repeat installation procedures.

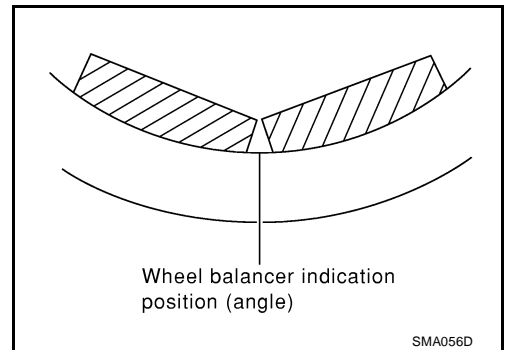

Wheel balance	Dynamic (At rim flange)	Static
Maximum allowable unbalance	5 g (0.17 oz) (one side)	10 g (0.35 oz)

Tire Rotation

1. Do not include the spare tire when rotating the tires.
2. When installing the wheel, tighten wheel nuts to the specified torque.

Wheel nuts : 108 N·m (11 kg·m, 80 ft·lb)

CAUTION:

- When installing wheels, tighten them diagonally by dividing the work two to three times in order to prevent the wheels from developing any distortion.
 - Be careful not to tighten wheel nut at torque exceeding the criteria for preventing strain of disc rotor.
3. Perform the ID registration, after tire rotation. Refer to [WT-21](#), "[WORK SUPPORT MODE](#)".

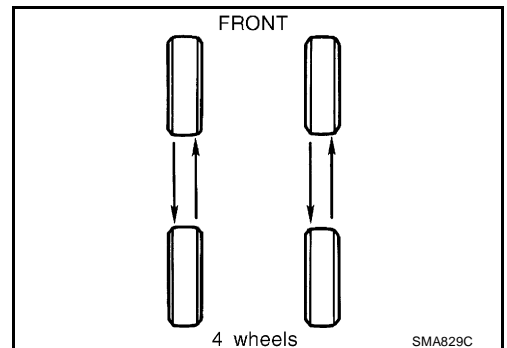

NLS0005T

A
B
C
D
E
F
G
H
I
J
K
MA
M

CHASSIS AND BODY MAINTENANCE

Checking Brake Fluid Level and Leaks

NLS00058

- If fluid level is extremely low, check brake system for leaks.

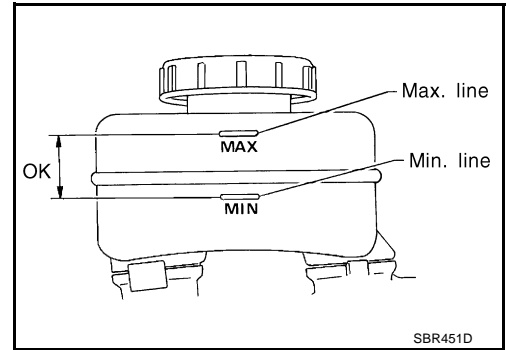

Checking Brake Lines and Cables

NLS00059

- Check brake fluid lines and parking brake cables for improper attachment, leaks, chafing, abrasions, deterioration, etc.

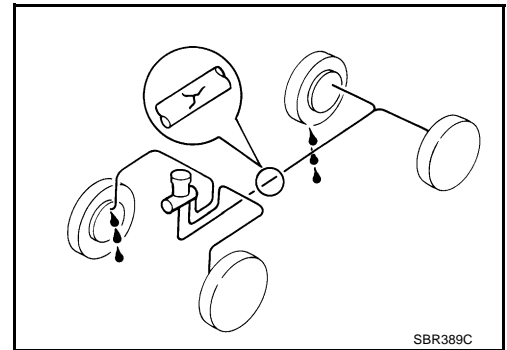

Changing Brake Fluid

NLS0005A

1. Drain brake fluid from each bleed valve.
2. Refill until new brake fluid comes out from each bleed valve. Use same procedure as in bleeding hydraulic system to refill brake fluid. Refer to [BR-11, "Bleeding Brake System"](#) .
 - Refill with recommended Genuine Brake Fluid or equivalent DOT 3 (US FMVSS No. 116). Refer to [MA-10, "RECOMMENDED FLUIDS AND LUBRICANTS"](#) .
 - Never reuse drained brake fluid.
 - Be careful not to splash brake fluid on painted areas.

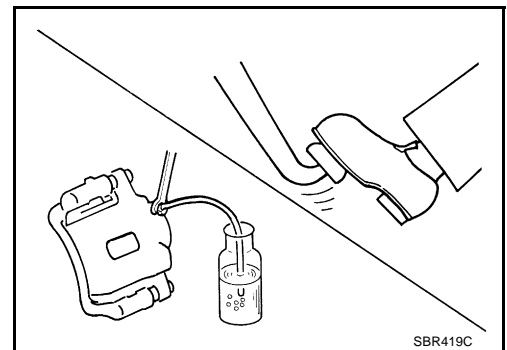

Checking Disc Brake ROTOR

NLS0005B

Check condition, wear, and damage.

	Front	Rear
Standard thickness (new)	28.0 mm (1.102 in)	16.0 mm (0.630 in)
Maximum runout (with it attached to the vehicle)	0.04 mm (0.0016 in)	0.05mm (0.0020 in)
Repair limit thickness	26.0 mm (1.024 in)	14.0 mm (0.551 in)

CHASSIS AND BODY MAINTENANCE

CALIPER

- Check for leakage.

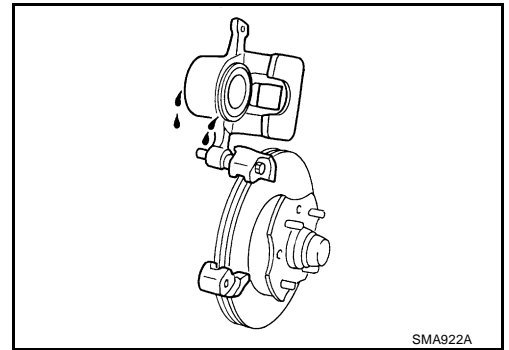

PAD

- Check for wear or damage.

Standard thickness (new)	9.5 mm (0.374 in)	8.5 mm (0.335 in)
Repair limit thickness	2.0 mm (0.079 in)	2.0 mm (0.079 in)

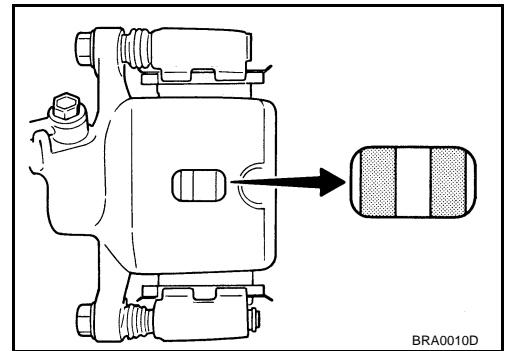

Checking Steering Gear and Linkage STEERING GEAR

- Check gear housing and boots for looseness, damage and grease leakage.
- Check connection with steering column for looseness.

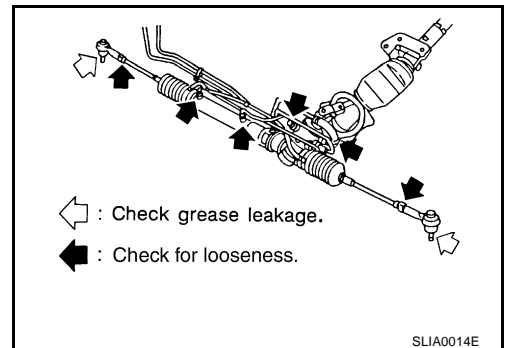

STEERING LINKAGE

Check ball joint, dust cover and other component parts for looseness, wear, damage and grease leakage.

Checking Power Steering Fluid and Lines

Check fluid level in reservoir tank with engine off.

Use "HOT" range at fluid temperatures of 50 to 80°C (122 to 176°F) or "COLD" range at fluid temperatures of 0 to 30°C (32 to 86°F).

CAUTION:

- Do not overfill.
- Recommended fluid is Genuine NISSAN PSF or equivalent. Refer to [MA-10, "RECOMMENDED FLUIDS AND LUBRICANTS"](#)

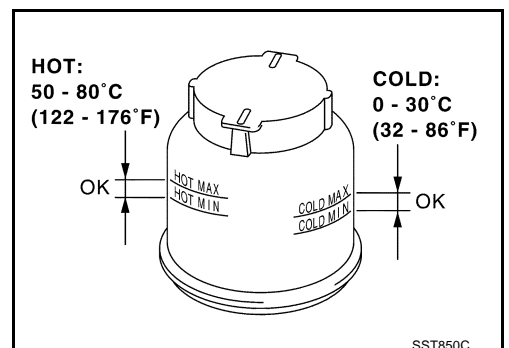

CHASSIS AND BODY MAINTENANCE

- Check lines for improper attachment, leaks, cracks, damage, loose connections, chafing and deterioration.
- Check rack boots for accumulation of power steering fluid.

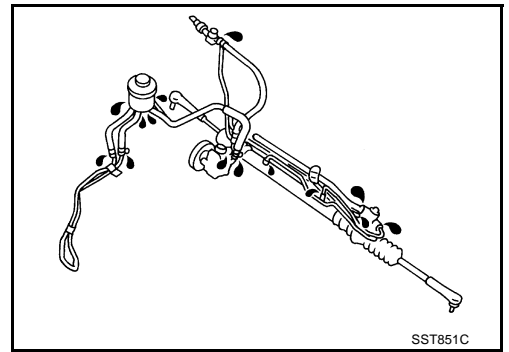

SST851C

NLS0005E

Axle and Suspension Parts

Check front and rear axle and suspension parts for excessive play, cracks, wear or other damage.

- Shake each wheel to check for excessive play.
- Check wheel bearings for smooth operation.
- Check axle and suspension nuts and bolts for looseness.
- Check strut (shock absorber) for oil leakage or other damage.
- Check suspension ball joint for grease leakage and ball joint dust cover for cracks or other damage.

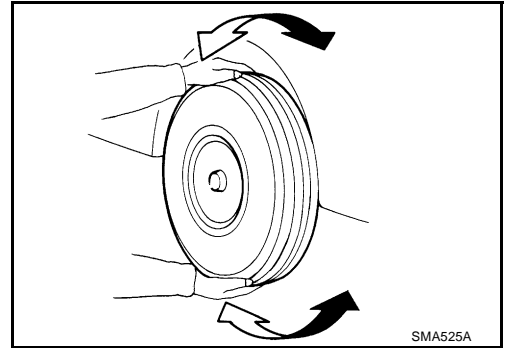

SMA525A

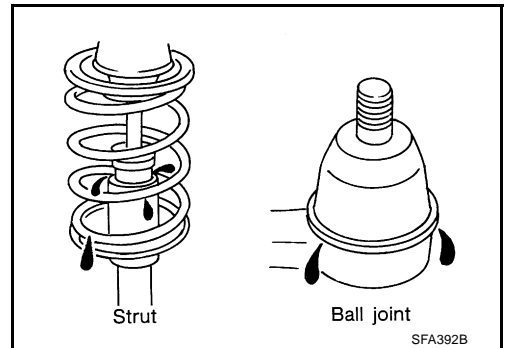

Strut

Ball joint

SFA392B

NLS0005F

Drive Shaft

Check boot and drive shaft for cracks, wear, damage and grease leakage.

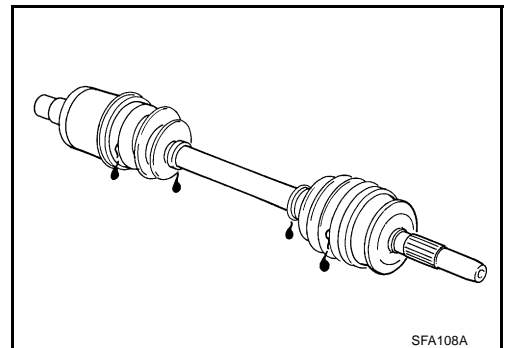

SFA108A

CHASSIS AND BODY MAINTENANCE

Lubricating Locks, Hinges and Hood Latch

NLS0005G

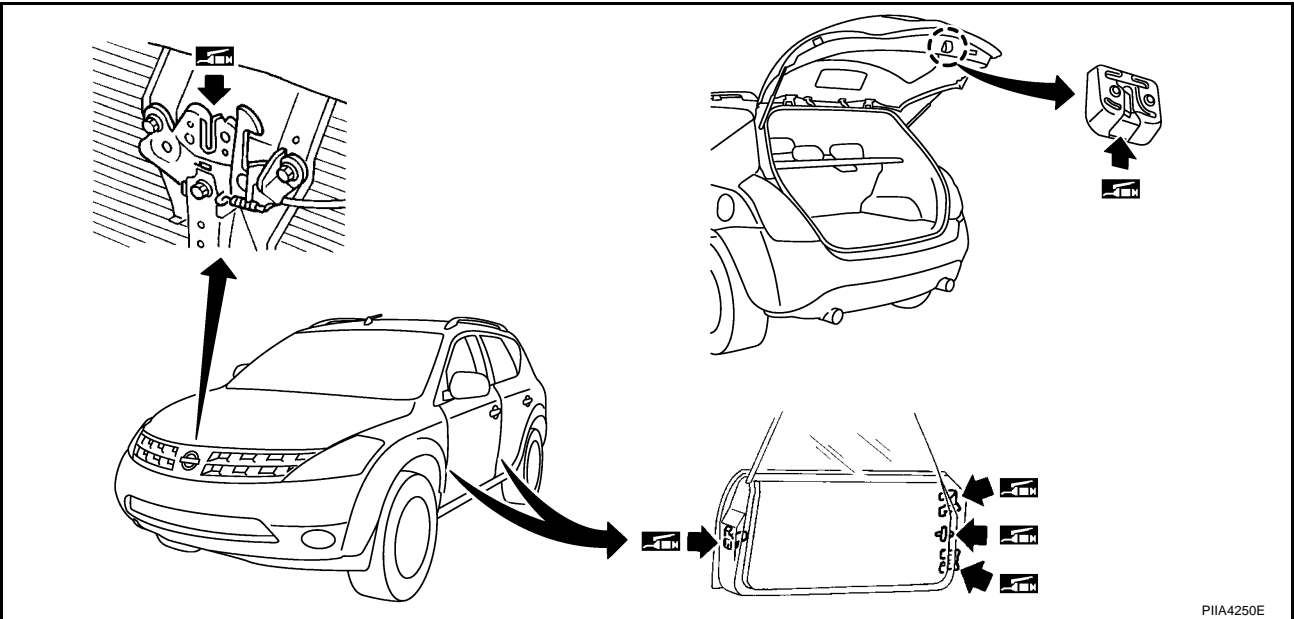

PIIA4250E

Checking Seat Belt, Buckles, Retractors, Anchors and Adjusters

NLS0005K

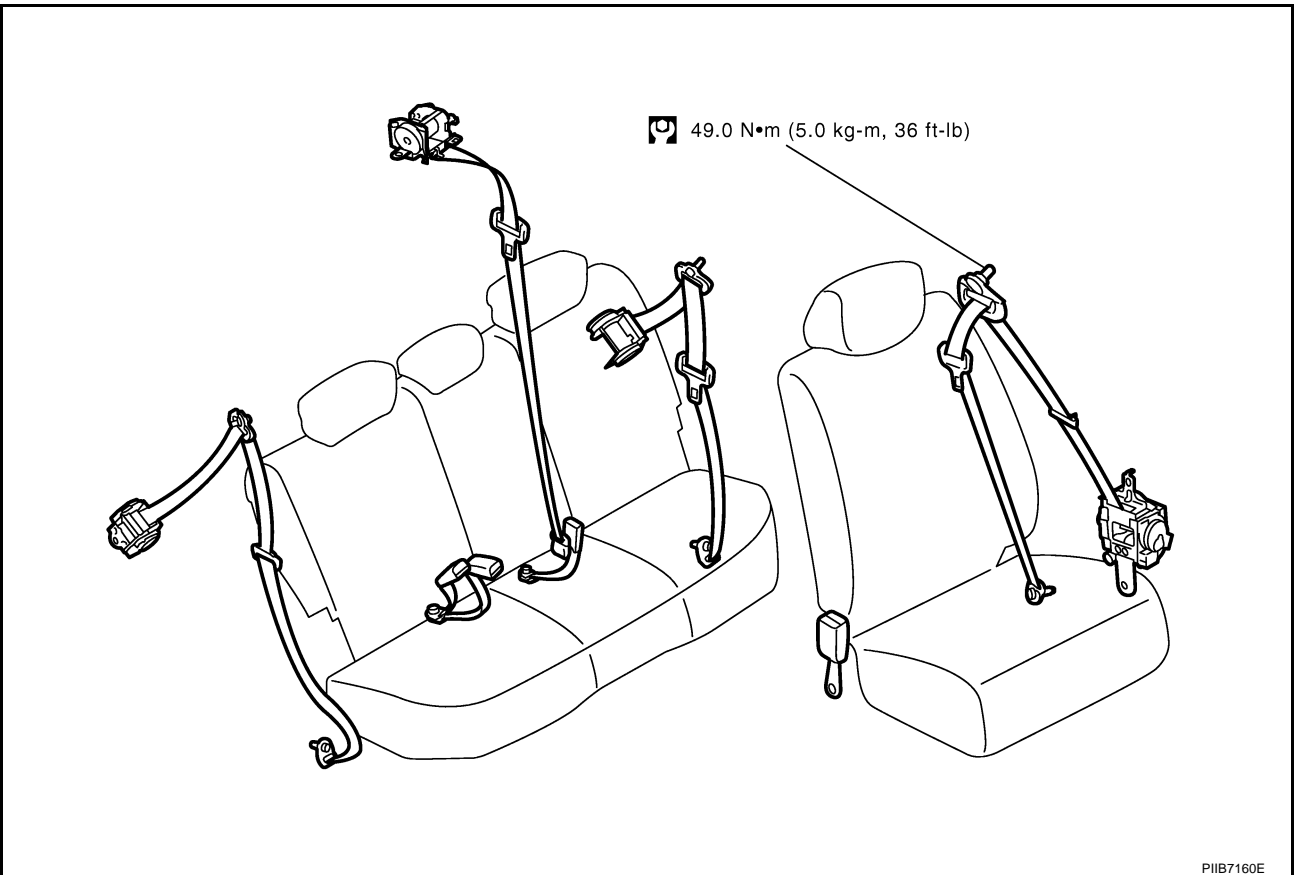

PIIB7160E

CAUTION:

- After any collision, inspect all seat belt assemblies, including retractors and other attached hardware (i.e. anchor bolt, guide rail set). Nissan recommends to replace all seat belt assemblies in use during a collision, unless not damaged and properly operating after minor collision. Also inspect seat belt assemblies not in use during a collision, and replace if damaged or improperly operating. Seat belt pre-tensioner should be replaced even if the seat belts are not in use during a frontal collision where the driver and passenger air bags are deployed.
- If any component of seat belt assembly is questionable, do not repair.

A
B
C
D
E
F
G
H
I
J
K
MA
M

CHASSIS AND BODY MAINTENANCE

Replace as seat belt assembly.

- **If webbing is cut, frayed, or damaged, replace belt assembly.**
- **Never oil tongue and buckle.**
- **Use a genuine NISSAN seat belt assembly.**

For details, refer to Refer to Service Manual in SB section.

- Check anchors for loose mounting
- Check belts for damage
- Check retractor for smooth operation
- Check function of buckles and tongues when buckled and released

SERVICE DATA AND SPECIFICATIONS (SDS)

SERVICE DATA AND SPECIFICATIONS (SDS)

PF0:00030

Standard and Limit BELT DEFLECTION AND TENSION

NLS00051

	Deflection adjustment		Unit: mm (in)	Tension adjustment*		Unit: N (kg, lb)
	Used belt		New belt	Used belt		New belt
	Limit	After adjustment		Limit	After adjustment	
Alternator and A/C compressor	7 (0.28)	4.2 - 4.6 (0.17 - 0.18)	3.7 - 4.1 (0.15 - 0.16)	294 (30, 66)	730 - 818 (74.5 - 83.5, 164 - 184)	838 - 926 (85.5 - 94.5, 188 - 208)
Power steering oil pump	11 (0.43)	7.3 - 8 (0.29 - 0.30)	6.5 - 7.2 (0.26 - 0.28)	196 (20, 44)	495 - 583 (50.5 - 59.5, 111 - 131)	603 - 691 (61.5 - 70.5, 135.6 - 155.4)
Applied pushing force	98 N (10 kg, 22 lb)			—		

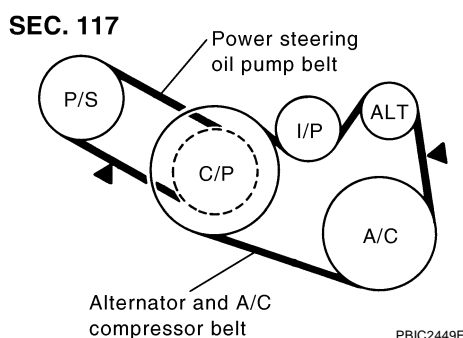

*: If belt tension gauge cannot be installed at check points shown, check drive belt tension at different location on the belt.

ENGINE COOLANT CAPACITY (APPROXIMATE)

Unit: ℓ (US qt, Imp qt)

Engine coolant capacity (With reservoir tank at "MAX" level)	9.6 (10-1/8, 8-1/2)
Reservoir tank engine coolant capacity (At "MAX" level)	0.8 (7/8, 3/4)

RADIATOR

Unit: kPa (kg/cm², psi)

Cap relief pressure	Standard	78 - 98 (0.8 - 1.0, 11 - 14)
	Limit	59 (0.6, 9)
Leakage testing pressure		157 (1.6, 23)

ENGINE OIL CAPACITY (APPROXIMATE)

Unit: ℓ (US qt, Imp qt)

Drain and refill	With oil filter change	4.0 (4-1/4, 3-1/2)
	Without oil filter change	3.7 (3-7/8, 3-1/4)
Dry engine (Overhaul)		5.0 (5-1/4, 4-3/8)

SPARK PLUG (PLATINUM-TIPPED TYPE)

Make	NGK
Standard type	PLFR5A-11
Hot type	PLFR4A-11
Cold type	PLFR6A-11
Gap (Nominal)	1.1 mm (0.043 in)

SERVICE DATA AND SPECIFICATIONS (SDS)

WHEEL BALANCE

Maximum allowable unbalance	Dynamic (At rim flange)	Less than 5 g (0.17 oz) (one side)
	Static (At rim flange)	Less than 10 g (0.35 oz)

Tightening Torque

NLS0005J

Unit: N·m (kg-m, ft-lb)

Unit: N·m (kg-m, in-lb)*

Drive belt idler pulley lock nut (A)	34.8 (3.5, 26)
Drive belt adjusting nut (B)	5.4 (0.55, 48)*
Drive belt adjusting bolt lock bolt (C)	28.0 (2.9, 21)
Power steering oil pump mounting bolt (D)	43.2 (4.4, 32)
Radiator drain plug	0.78 - 1.56 (0.08 - 0.15, 7 - 13)*
Oil pan drain plug	34.3 (3.5, 25)
Oil filter	17.6 (1.8, 13)
Spark plug	24.5 (2.5, 18)