

A  
B

# SECTION HAC

## HEATER & AIR CONDITIONING CONTROL SYSTEM C

### CONTENTS D

<b>WITHOUT 7 INCH DISPLAY</b>		
<b>BASIC INSPECTION</b> .....	5	
<b>DIAGNOSIS AND REPAIR WORKFLOW</b> .....	5	
Work Flow .....	5	
<b>INSPECTION AND ADJUSTMENT</b> .....	7	
Description & Inspection .....	7	
Temperature Setting Trimmer .....	9	
Foot Position Setting Trimmer .....	9	
Inlet Port Memory Function (FRE) .....	10	
Inlet Port Memory Function (REC) .....	10	
<b>SYSTEM DESCRIPTION</b> .....	11	
<b>COMPRESSOR CONTROL FUNCTION</b> .....	11	
Description .....	11	
Component Part Location .....	12	
Component's Role .....	14	
<b>AUTOMATIC AIR CONDITIONER SYSTEM</b> ....	15	
System Diagram .....	15	
System Description .....	15	
Component Part Location .....	23	
Component Description .....	26	
<b>MODE DOOR CONTROL SYSTEM</b> .....	27	
System Diagram .....	27	
System Description .....	27	
<b>UPPER VENTILATOR DOOR CONTROL SYSTEM</b> .....	29	
System Diagram .....	29	
System Description .....	29	
<b>AIR MIX DOOR CONTROL SYSTEM</b> .....	31	
System Diagram .....	31	
System Description .....	31	
<b>INTAKE DOOR CONTROL SYSTEM</b> .....	33	
System Diagram .....	33	
System Description .....	33	
System Description .....	33	F
<b>BLOWER MOTOR CONTROL SYSTEM</b> .....	35	
System Diagram .....	35	
System Description .....	35	G
<b>MAGNET CLUTCH CONTROL SYSTEM</b> .....	37	
System Diagram .....	37	
System Description .....	37	H
<b>CAN COMMUNICATION SYSTEM</b> .....	38	
System Description .....	38	HAC
<b>DIAGNOSIS SYSTEM (HVAC)</b> .....	39	
CONSULT-III Function .....	39	J
<b>DTC/CIRCUIT DIAGNOSIS</b> .....	43	
<b>U1000 CAN COMM CIRCUIT</b> .....	43	
Description .....	43	K
DTC Logic .....	43	
Diagnosis Procedure .....	43	L
<b>U1010 CONTROL UNIT (CAN)</b> .....	44	
Description .....	44	M
DTC Logic .....	44	
Diagnosis Procedure .....	44	
<b>B257B, B257C AMBIENT SENSOR</b> .....	45	
Description .....	45	N
DTC Logic .....	45	
Diagnosis Procedure .....	46	
Component Inspection .....	47	O
<b>B2578, B2579 IN-VEHICLE SENSOR</b> .....	48	
Description .....	48	P
DTC Logic .....	48	
Diagnosis Procedure .....	49	
Component Inspection .....	50	
<b>B2581, B2582 INTAKE SENSOR</b> .....	51	
Description .....	51	
DTC Logic .....	51	

Diagnosis Procedure .....	51	A/C CONTROL : Diagnosis Procedure .....	77
Component Inspection .....	52	<b>A/C DISPLAY .....</b>	<b>78</b>
<b>B2630, B2631 SUNLOAD SENSOR .....</b>	<b>54</b>	A/C DISPLAY : Diagnosis Procedure .....	78
Description .....	54	<b>ECU DIAGNOSIS INFORMATION .....</b>	<b>79</b>
DTC Logic .....	54	<b>ECM .....</b>	<b>79</b>
Diagnosis Procedure .....	55	Reference Value .....	79
Component Inspection .....	56	<b>A/C AUTO AMP. ....</b>	<b>94</b>
<b>B2632, B2633 AIR MIX DOOR MOTOR</b>		Reference Value .....	94
<b>(DRIVER SIDE) .....</b>	<b>57</b>	Wiring Diagram - AIR CONDITIONER CONTROL	
Description .....	57	SYSTEM - .....	96
DTC Logic .....	57	Fail-Safe .....	105
Diagnosis Procedure .....	58	DTC Inspection Priority Chart .....	106
<b>B2634, B2635 AIR MIX DOOR MOTOR (PAS-</b>		DTC Index .....	106
<b>SENGER SIDE) .....</b>	<b>59</b>	<b>SYMPTOM DIAGNOSIS .....</b>	<b>108</b>
Description .....	59	<b>AIR CONDITIONER CONTROL .....</b>	<b>108</b>
DTC Logic .....	59	Diagnosis Chart By Symptom .....	108
Diagnosis Procedure .....	60	<b>INSUFFICIENT COOLING .....</b>	<b>109</b>
<b>B2636, B2637, B2638, B2639, B2654, B2655</b>		Description .....	109
<b>MODE DOOR MOTOR .....</b>	<b>61</b>	Inspection procedure .....	109
Description .....	61	<b>INSUFFICIENT HEATING .....</b>	<b>112</b>
DTC Logic .....	61	Description .....	112
Diagnosis Procedure .....	62	Inspection procedure .....	112
<b>B263D, B263E, B263F INTAKE DOOR MO-</b>		<b>NOISE .....</b>	<b>115</b>
<b>TOR .....</b>	<b>64</b>	Description .....	115
Description .....	64	Inspection procedure .....	115
DTC Logic .....	64	<b>MEMORY FUNCTION DOES NOT OPERATE.</b>	<b>117</b>
Diagnosis Procedure .....	65	Description .....	117
<b>B2661, B2662, B2663 UPPER VENTILATOR</b>		Inspection procedure .....	117
<b>DOOR MOTOR .....</b>	<b>66</b>	<b>PRECAUTION .....</b>	<b>118</b>
Description .....	66	<b>PRECAUTIONS .....</b>	<b>118</b>
DTC Logic .....	66	<b>FOR USA AND CANADA .....</b>	<b>118</b>
Diagnosis Procedure .....	67	FOR USA AND CANADA : Precaution for Supple-	
<b>BLOWER MOTOR .....</b>	<b>69</b>	mental Restraint System (SRS) "AIR BAG" and	
Description .....	69	"SEAT BELT PRE-TENSIONER" .....	118
Component Function Check .....	69	<b>FOR MEXICO .....</b>	<b>118</b>
Diagnosis Procedure .....	69	FOR MEXICO : Precaution for Supplemental Re-	
Component Inspection .....	72	straint System (SRS) "AIR BAG" and "SEAT BELT	
<b>MAGNET CLUTCH .....</b>	<b>73</b>	PRE-TENSIONER" .....	118
Description .....	73	Precaution Necessary for Steering Wheel Rota-	
Component Function Check .....	73	tion after Battery Disconnect .....	119
Diagnosis Procedure .....	73	Precaution for Procedure without Cowl Top Cover.	119
<b>A/C CONTROL SIGNAL CIRCUIT .....</b>	<b>75</b>	Precautions For Xenon Headlamp Service .....	119
Diagnosis Procedure .....	75	Working with HFC-134a (R-134a) .....	120
<b>POWER SUPPLY AND GROUND CIRCUIT ....</b>	<b>76</b>	General Refrigerant Precaution .....	120
<b>A/C AUTO AMP. ....</b>	<b>76</b>	Refrigerant Connection .....	121
A/C AUTO AMP. : Description .....	76	Service Equipment .....	123
A/C AUTO AMP. : Component Function Check ....	76	<b>COMPRESSOR .....</b>	<b>125</b>
A/C AUTO AMP. : Diagnosis Procedure .....	76		
<b>A/C CONTROL .....</b>	<b>77</b>		

General Precautions .....	125	<b>DTC/CIRCUIT DIAGNOSIS .....</b>	<b>165</b>
<b>FLUORESCENT LEAK DETECTOR .....</b>	<b>126</b>	<b>U1000 CAN COMM CIRCUIT .....</b>	<b>165</b>
General Precautions .....	126	Description .....	165
<b>WITH 7 INCH DISPLAY</b>		DTC Logic .....	165
<b>BASIC INSPECTION .....</b>	<b>127</b>	Diagnosis Procedure .....	165
<b>DIAGNOSIS AND REPAIR WORKFLOW .....</b>	<b>127</b>	<b>U1010 CONTROL UNIT (CAN) .....</b>	<b>166</b>
Work Flow .....	127	Description .....	166
<b>INSPECTION AND ADJUSTMENT .....</b>	<b>129</b>	DTC Logic .....	166
Description & Inspection .....	129	Diagnosis Procedure .....	166
Temperature Setting Trimmer .....	131	<b>B257B, B257C AMBIENT SENSOR .....</b>	<b>167</b>
Foot Position Setting Trimmer .....	131	Description .....	167
Inlet Port Memory Function (FRE) .....	132	DTC Logic .....	167
Inlet Port Memory Function (REC) .....	132	Diagnosis Procedure .....	168
<b>SYSTEM DESCRIPTION .....</b>	<b>133</b>	Component Inspection .....	169
<b>COMPRESSOR CONTROL FUNCTION .....</b>	<b>133</b>	<b>B2578, B2579 IN-VEHICLE SENSOR .....</b>	<b>170</b>
Description .....	133	Description .....	170
Fail-Safe .....	134	DTC Logic .....	170
Component Part Location .....	134	Diagnosis Procedure .....	171
Component's Role .....	137	Component Inspection .....	172
<b>AUTOMATIC AIR CONDITIONER SYSTEM ..</b>	<b>138</b>	<b>B2581, B2582 INTAKE SENSOR .....</b>	<b>173</b>
System Diagram .....	138	Description .....	173
System Description .....	138	DTC Logic .....	173
Component Part Location .....	145	Diagnosis Procedure .....	173
Component Description .....	148	Component Inspection .....	174
<b>MODE DOOR CONTROL SYSTEM .....</b>	<b>149</b>	<b>B2630, B2631 SUNLOAD SENSOR .....</b>	<b>176</b>
System Diagram .....	149	Description .....	176
System Description .....	149	DTC Logic .....	176
<b>UPPER VENTILATOR DOOR CONTROL</b>		Diagnosis Procedure .....	177
<b>SYSTEM .....</b>	<b>151</b>	Component Inspection .....	178
System Diagram .....	151	<b>B2632, B2633 AIR MIX DOOR MOTOR</b>	
System Description .....	151	<b>(DRIVER SIDE) .....</b>	<b>179</b>
<b>AIR MIX DOOR CONTROL SYSTEM .....</b>	<b>153</b>	Description .....	179
System Diagram .....	153	DTC Logic .....	179
System Description .....	153	Diagnosis Procedure .....	180
<b>INTAKE DOOR CONTROL SYSTEM .....</b>	<b>155</b>	<b>B2634, B2635 AIR MIX DOOR MOTOR (PAS-</b>	
System Diagram .....	155	<b>SENGER SIDE) .....</b>	<b>181</b>
System Description .....	155	Description .....	181
<b>BLOWER MOTOR CONTROL SYSTEM .....</b>	<b>157</b>	DTC Logic .....	181
System Diagram .....	157	Diagnosis Procedure .....	182
System Description .....	157	<b>B2636, B2637, B2638, B2639, B2654, B2655</b>	
<b>MAGNET CLUTCH CONTROL SYSTEM .....</b>	<b>159</b>	<b>MODE DOOR MOTOR .....</b>	<b>183</b>
System Diagram .....	159	Description .....	183
System Description .....	159	DTC Logic .....	183
<b>CAN COMMUNICATION SYSTEM .....</b>	<b>160</b>	Diagnosis Procedure .....	184
System Description .....	160	<b>B263D, B263E, B263F INTAKE DOOR MO-</b>	
<b>DIAGNOSIS SYSTEM (HVAC) .....</b>	<b>161</b>	<b>TOR .....</b>	<b>186</b>
CONSULT-III Function .....	161	Description .....	186
		DTC Logic .....	186
		Diagnosis Procedure .....	187

A  
B  
C  
D  
E  
F  
G  
H  
HAC  
J  
K  
L  
M  
N  
O  
P

<b>B2661, B2662, B2663 UPPER VENTILATOR</b>	Description .....	229
<b>DOOR MOTOR</b> .....	Inspection procedure .....	229
Description .....		188
DTC Logic .....		188
Diagnosis Procedure .....		189
<b>BLOWER MOTOR</b> .....		191
Description .....		191
Component Function Check .....		191
Diagnosis Procedure .....		191
Component Inspection .....		194
<b>MAGNET CLUTCH</b> .....		195
Description .....		195
Component Function Check .....		195
Diagnosis Procedure .....		195
<b>POWER SUPPLY AND GROUND CIRCUIT</b> ..		197
<b>A/C AUTO AMP.</b> .....		197
A/C AUTO AMP. : Description .....		197
A/C AUTO AMP. : Component Function Check ...		197
A/C AUTO AMP. : Diagnosis Procedure .....		197
<b>ECU DIAGNOSIS INFORMATION</b> .....		199
<b>ECM</b> .....		199
Reference Value .....		199
<b>A/C AUTO AMP.</b> .....		214
Reference Value .....		214
Wiring Diagram - AIR CONDITIONER CONTROL		
SYSTEM - .....		216
Fail-Safe .....		225
DTC Inspection Priority Chart .....		226
DTC Index .....		226
<b>SYMPTOM DIAGNOSIS</b> .....		228
<b>AIR CONDITIONER CONTROL</b> .....		228
Diagnosis Chart By Symptom .....		228
<b>INSUFFICIENT COOLING</b> .....		229
	Description .....	229
	Inspection procedure .....	229
<b>INSUFFICIENT HEATING</b> .....		232
Description .....		232
Inspection procedure .....		232
<b>NOISE</b> .....		235
Description .....		235
Inspection procedure .....		235
<b>MEMORY FUNCTION DOES NOT OPERATE.</b>		237
Description .....		237
Inspection procedure .....		237
<b>PRECAUTION</b> .....		238
<b>PRECAUTIONS</b> .....		238
<b>FOR USA AND CANADA</b> .....		238
FOR USA AND CANADA : Precaution for Supple-		
mental Restraint System (SRS) "AIR BAG" and		
"SEAT BELT PRE-TENSIONER" .....		238
<b>FOR MEXICO</b> .....		238
FOR MEXICO : Precaution for Supplemental Re-		
straint System (SRS) "AIR BAG" and "SEAT BELT		
PRE-TENSIONER" .....		238
Precaution Necessary for Steering Wheel Rota-		
tion after Battery Disconnect .....		239
Precaution for Procedure without Cowl Top Cover.		239
Precautions For Xenon Headlamp Service .....		239
Working with HFC-134a (R-134a) .....		240
General Refrigerant Precaution .....		240
Refrigerant Connection .....		241
Service Equipment .....		243
<b>COMPRESSOR</b> .....		245
General Precautions .....		245
<b>FLUORESCENT LEAK DETECTOR</b> .....		246
General Precautions .....		246

**BASIC INSPECTION**

DIAGNOSIS AND REPAIR WORKFLOW

Work Flow

INFOID:000000005514569

OVERALL SEQUENCE

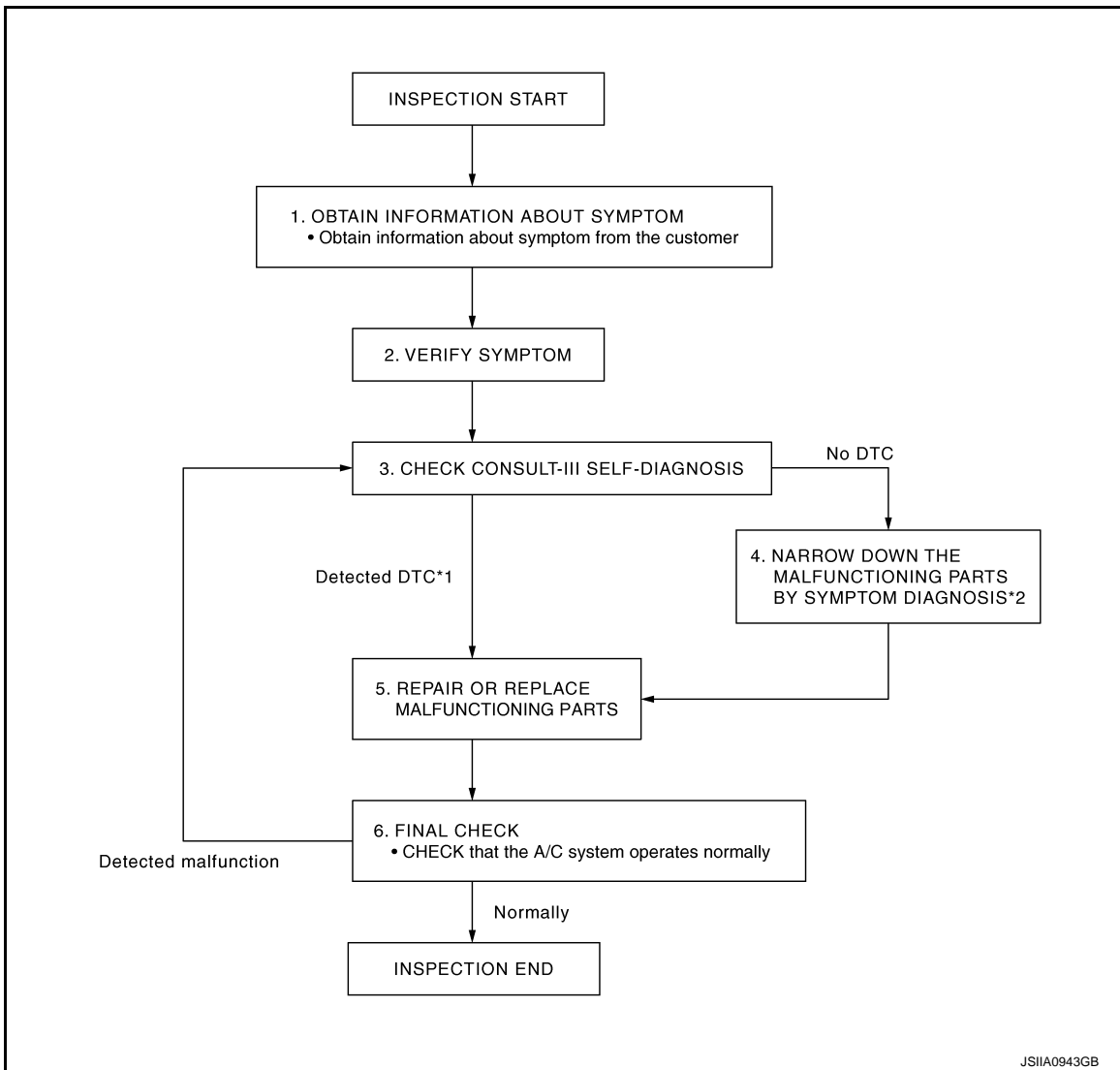

\*1: Refer to [HAC-106. "DTC Index"](#).

\*2: Refer to [HAC-108. "Diagnosis Chart By Symptom"](#).

DETAILED FLOW

**1. OBTAIN INFORMATION ABOUT SYMPTOM**

Interview the customer to obtain as much information as possible about the conditions and environment under which the malfunction occurred.

>> GO TO 2.

**2. VERIFY SYMPTOM**

Verify the symptom with operational check based on the information obtained from the customer. Refer to [HAC-7. "Description & Inspection"](#).

>> GO TO 3.

## DIAGNOSIS AND REPAIR WORKFLOW

< BASIC INSPECTION >

[WITHOUT 7 INCH DISPLAY]

---

### 3. CHECK WITH SELF-DIAGNOSIS FUNCTION OF CONSULT-III

---

Using CONSULT-III, perform "SELF-DIAGNOSIS RESULTS" of HVAC. Refer to [HAC-106, "DTC Index"](#).

Are self-diagnosis results normal?

YES >> GO TO 4.

NO >> GO TO 5.

### 4. NARROW DOWN THE MALFUNCTIONING PARTS BY SYMPTOM DIAGNOSIS

---

Perform symptom diagnosis and narrow down the malfunctioning parts. Refer to [HAC-108, "Diagnosis Chart By Symptom"](#).

>> GO TO 5.

### 5. REPAIR OR REPLACE

---

Repair or replace malfunctioning parts.

**NOTE:**

If DTC is displayed, erase DTC after repairing or replacing malfunctioning parts.

>> GO TO 6.

### 6. FINAL CHECK

---

Check that the A/C system operates normally.

Is the inspection result normal?

YES >> INSPECTION END

NO >> GO TO 3.

# INSPECTION AND ADJUSTMENT

< BASIC INSPECTION >

[WITHOUT 7 INCH DISPLAY]

## INSPECTION AND ADJUSTMENT

### Description & Inspection

INFOID:000000005514570

#### DESCRIPTION

The purpose of the operational check is to check that the individual system operates normally.

**Conditions : Engine running at normal operating temperature**

#### INSPECTION PROCEDURE

##### 1.CHECK MEMORY FUNCTION

1. Start the engine.
2. Operate the temperature control switch (driver side) and raise the temperature setting to 32°C (90°F).
3. Press the ON/OFF switch.
4. Turn the ignition switch OFF.
5. Turn the ignition switch ON.
6. Press the AUTO switch.
7. Check that the temperature setting before turning the ignition switch OFF is stored.

Is the inspection result normal?

YES >> GO TO 2.

NO >> Memory function malfunction: [HAC-117, "Inspection procedure"](#).

##### 2.CHECK BLOWER MOTOR SPEED

1. Start the engine.
2. Operate the fan control dial. Check that the fan speed changes. Check the operation for all fan speeds.
3. Set the fan speed to speed 7.

Is the inspection result normal?

YES >> GO TO 3.

NO >> Blower motor system malfunction: [HAC-69, "Diagnosis Procedure"](#).

##### 3.CHECK DISCHARGE AIR(MODE SWITCH AND DEF SWITCH)

1. Press the MODE switch and the DEF switch.
2. Check that the air outlets change according to each indicated air outlet by placing a hand in front of the outlets. Refer to [HAC-15, "System Description"](#).

#### NOTE:

Confirm that the compressor clutch is engaged (sound or visual inspection) and the intake door position is at the FRE when the D/F or DEF is selected.

Is the inspection result normal?

YES >> GO TO 4.

NO >> Mode door system malfunction: [HAC-62, "Diagnosis Procedure"](#).

##### 4.CHECK DISCHARGE AIR (UPPER VENT SWITCH)

1. Press the UPPER VENT switch.
2. The UPPER VENT switch indicator is turned ON.

A  
B  
C  
D  
E  
F  
G  
H  
HAC  
J  
K  
L  
M  
N  
O  
P

# INSPECTION AND ADJUSTMENT

< BASIC INSPECTION >

[WITHOUT 7 INCH DISPLAY]

3. Check that the air blown from the UPPER VENT does not greatly deviate from the air mix ratio.

Discharge air flow							
Mode position indication	Condition	Air outlet/distribution					
		VENT			FOOT		DEF
		Front	Upper	Rear	Front	Rear	
	DUAL switch: OFF UPPER VENT switch : ON	81%	8%	11%	—	—	—
		41%	10%	17%	24%	8%	—
		12%	12%	16%	27%	10%	23%
		11%	11%	14%	25%	10%	29%
		11%	11%	12%	—	—	66%

JPIIA0509GB

4. Press the UPPER VENT switch again.  
 5. The UPPER VENT switch indicator is turned OFF.  
 6. The air blown from the UPPER VENT stops.

Does it operate normally?

YES >> GO TO 5.

NO >> Upper ventilator door system malfunction: [HAC-67. "Diagnosis Procedure"](#).

## 5.CHECK INTAKE AIR

1. Press the intake switch. Indicator is turned ON (REC).  
 2. Press the intake switch again. Indicator is turned OFF (FRE).  
 3. Listen for the intake door position change. (Slight change of blower sound can be heard.)

**NOTE:**

Confirm that the compressor clutch is engaged (sound or visual inspection) and the intake door position is at the FRE when the D/F or DEF is selected.

Is the inspection result normal?

YES >> GO TO 6.

NO >> Intake door system malfunction: [HAC-65. "Diagnosis Procedure"](#).

## 6.CHECK A/C SWITCH

1. Press the A/C switch.  
 2. The A/C switch indicator is turned ON.  
 Confirm that the compressor clutch engages (sound or visual inspection).

Is the inspection result normal?

YES >> GO TO 7.

NO >> Magnet clutch system malfunction: [HAC-73. "Diagnosis Procedure"](#).

## 7.CHECK WITH TEMPERATURE SETTING LOWERED

1. Operate the compressor.  
 2. Operate the temperature control switch (driver side) and lower the temperature setting to 18°C (60°F).  
 3. Check that the cool air blows from the outlets.

Is the inspection result normal?

YES >> GO TO 8.

NO >> Insufficient cooling: [HAC-109. "Inspection procedure"](#).

## 8.CHECK WITH TEMPERATURE SETTING RAISED

1. Operate the temperature control switch (driver side) and raise the temperature setting to 32°C (90°F) after warming up the engine.  
 2. Check that the warm air blows from the outlets.

Is the inspection result normal?

YES >> GO TO 9.

NO >> Insufficient heating: [HAC-112. "Inspection procedure"](#).



# INSPECTION AND ADJUSTMENT

< BASIC INSPECTION >

[WITHOUT 7 INCH DISPLAY]

## 9. CHECK LH/RH INDEPENDENT TEMPERATURE ADJUSTMENT FUNCTION

1. Press the DUAL switch, and then check that "DUAL" is shown on the display.
2. Operate the temperature control switch (driver side). Check that the discharge air temperature (driver side) changes.
3. Operate the temperature control switch (passenger side). Check that the discharge air temperature (passenger side) changes.
4. Press the DUAL switch, and then check that the temperature setting (LH/RH) is unified to the driver side temperature setting.

Is the inspection result normal?

YES >> GO TO 10.

NO >> Refer to [HAC-108. "Diagnosis Chart By Symptom"](#) and perform the appropriate diagnosis.

## 10. CHECK AUTO MODE

1. Press the AUTO switch, and then check that "AUTO" is shown on the display.
2. Operate the temperature control switch (driver side). Check that the fan speed or outlet changes (the discharge air temperature or fan speed varies depending on the ambient temperature, in-vehicle temperature, and temperature setting).

Is the inspection result normal?

YES >> INSPECTION END

NO >> Refer to [HAC-108. "Diagnosis Chart By Symptom"](#) and perform the appropriate diagnosis.

## Temperature Setting Trimmer

INFOID:000000005514571

### Description

If the temperature felt by the customer is different than the air flow temperature controlled by the temperature setting, the auto amplifier control temperature can be adjusted to compensate for the temperature setting.

### How to set

Using CONSULT-III, perform "TEMP SET CORRECT" on "WORK SUPPORT" of HVAC.

Work support items	Display (°F)	Display (°C)
TEMP SET CORRECT	6	3.0
	5	2.5
	4	2.0
	3	1.5
	2	1.0
	1	0.5
	0 (initial status)	0 (initial status)
	-1	-0.5
	-2	-1.0
	-3	-1.5
	-4	-2.0
	-5	-2.5
	-6	-3.0

### NOTE:

- When the temperature setting is set to 25.0°C (77°F) and -3.0°C (-6°F), the temperature controlled by auto amp is 25.0°C (77°F) - 3.0°C (6°F) = 22.0°C (71°F) and the temperature becomes lower than the temperature setting.
- When the battery cable is disconnected from the negative terminal or when the battery voltage becomes 10V or less, the setting of the difference between the temperature setting and control temperature may be cancelled.

## Foot Position Setting Trimmer

INFOID:000000005514572

### Description

In the FOOT mode, the air blowing to the DEF can be turned ON/OFF.

# INSPECTION AND ADJUSTMENT

< BASIC INSPECTION >

[WITHOUT 7 INCH DISPLAY]

## How to set

Using CONSULT-III, perform "BLOW SET" on "WORK SUPPORT" of HVAC.

Work support items	Display	DEF door position	
		Auto control	Manual control
BLOW SET	Mode 1	OPEN	CLOSE
	Mode 2 (initial status)	OPEN	OPEN
	Mode 3	CLOSE	OPEN
	Mode 4	CLOSE	CLOSE

### NOTE:

When the battery cable is disconnected from the negative terminal or when the battery voltage becomes 10V or less, the setting of the discharge air mix ratio in FOOT mode may be cancelled.

## Inlet Port Memory Function (FRE)

INFOID:000000005514573

### Description

- If the ignition switch is turned to the OFF position while the FRE switch is set to ON (fresh air intake), "Perform the memory" or "Do not perform the memory" of the FRE switch ON (fresh air intake) condition can be selected.
- If "Perform the memory" was set, the FRE switch will be ON (fresh air intake) when turning the ignition switch to the ON position again.
- If "Do not perform the memory" was set, the air inlets will be controlled automatically when turning the ignition switch to the ON position again.

### How to set

Using CONSULT-III, perform "FRE MEMORY SET" on "WORK SUPPORT" of HVAC.

Work support items	Display	Setting
FRE MEMORY SET	WITHOUT	Perform the memory of manual FRE
	WITH (initial status)	Do not perform the memory of manual FRE (auto control)

### NOTE:

When the battery cable is disconnected from the negative terminal or when the battery voltage becomes 10V or less, the setting of the FRE switch memory function may be cancelled.

## Inlet Port Memory Function (REC)

INFOID:000000005514574

### Description

- If the ignition switch is turned to the OFF position while the REC switch is set to ON (recirculation), "Perform the memory" or "Do not perform the memory" of the REC switch ON (recirculation) condition can be selected.
- If "Perform the memory" was set, the REC switch will be ON (recirculation) when turning the ignition switch to the ON position again.
- If "Do not perform the memory" was set, the air inlets will be controlled automatically when turning the ignition switch to the ON position again.

### How to set

Using CONSULT-III, perform "REC MEMORY SET" on "WORK SUPPORT" of HVAC.

Work support items	Display	Setting
REC MEMORY SET	WITHOUT (initial status)	Perform the memory of manual REC
	WITH	Do not perform the memory of manual REC (auto control)

### NOTE:

When the battery cable is disconnected from the negative terminal or when the battery voltage becomes 10V or less, the setting of the REC switch memory function may be cancelled.

# COMPRESSOR CONTROL FUNCTION

< SYSTEM DESCRIPTION >

[WITHOUT 7 INCH DISPLAY]

## SYSTEM DESCRIPTION

### COMPRESSOR CONTROL FUNCTION

#### Description

INFOID:000000005514575

#### PRINCIPLE OF OPERATION

Compressor is not activated.

Functional circuit diagram

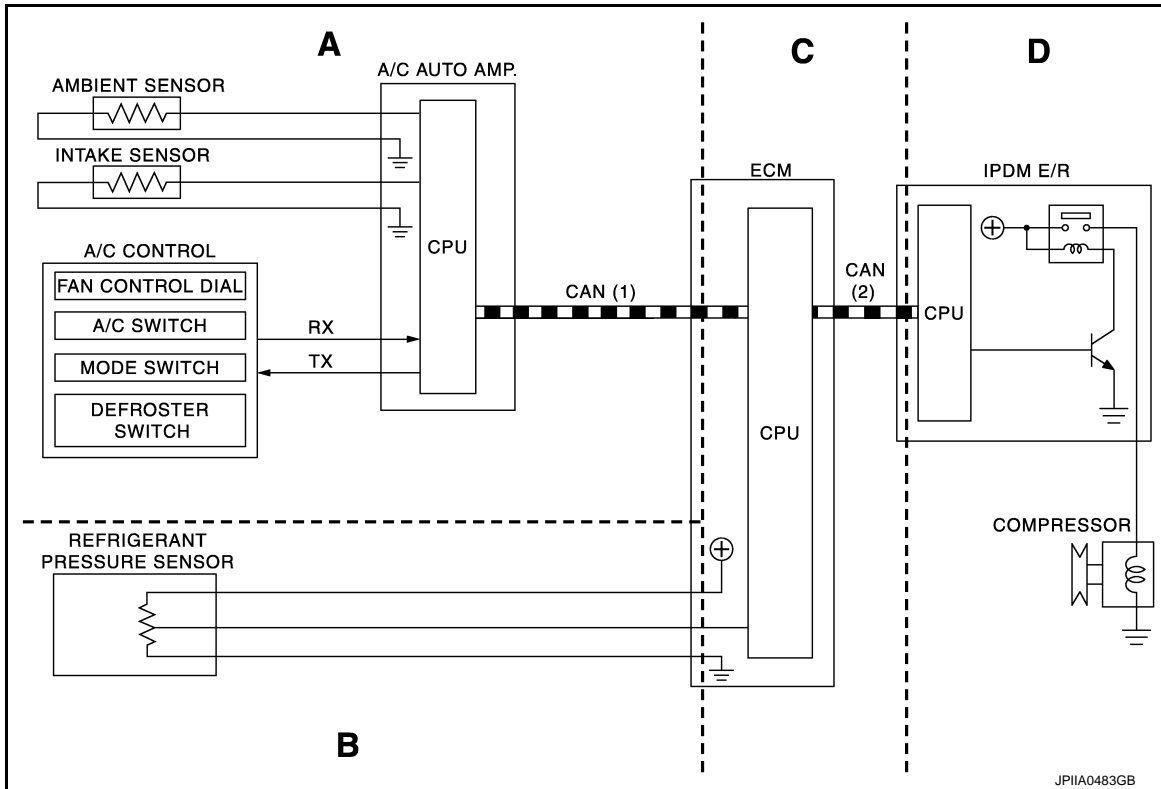

CAN (1) : A/C switch signal  
 : Blower fan motor switch signal  
 RX, TX : A/C switch signal  
 : Fan ON signal  
 : Defroster signal

CAN (2) : A/C Compressor request signal

#### Functional initial inspection chart

x: Applicable

Control unit	Diagnosis item	Location			
		A	B	C	D
A/C auto amp.	Self-diagnosis	x	—	—	—
	④ "HVAC" Data monitor	x	—	—	—
	Active test	x	—	—	x
ECM	Self-diagnosis function (CAN system diagnosis)	—	—	x	—
	Data monitor	—	x	x	—
IPDM E/R	Self-diagnosis function (CAN system diagnosis)	—	—	—	x
	Data monitor	—	—	x	—
	Auto active test	—	—	—	x

# COMPRESSOR CONTROL FUNCTION

< SYSTEM DESCRIPTION >

[WITHOUT 7 INCH DISPLAY]

## Component Part Location

INFOID:000000005514576

### ENGINE COMPARTMENT

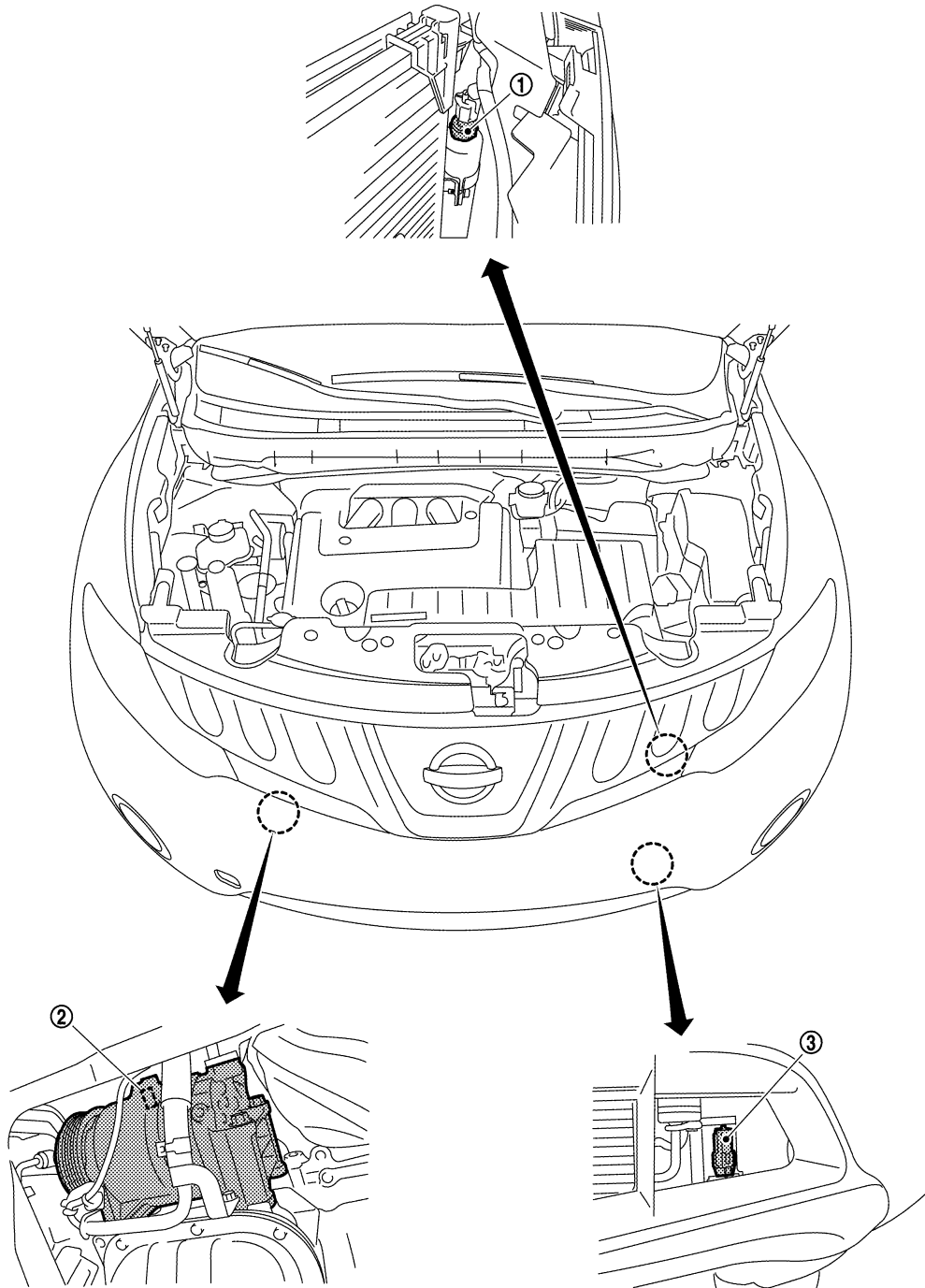

1. Refrigerant pressure sensor

2. Compressor (magnet clutch)

3. Ambient sensor

### PASSENGER COMPARTMENT

JPIIA0607ZZ

# COMPRESSOR CONTROL FUNCTION

< SYSTEM DESCRIPTION >

[WITHOUT 7 INCH DISPLAY]

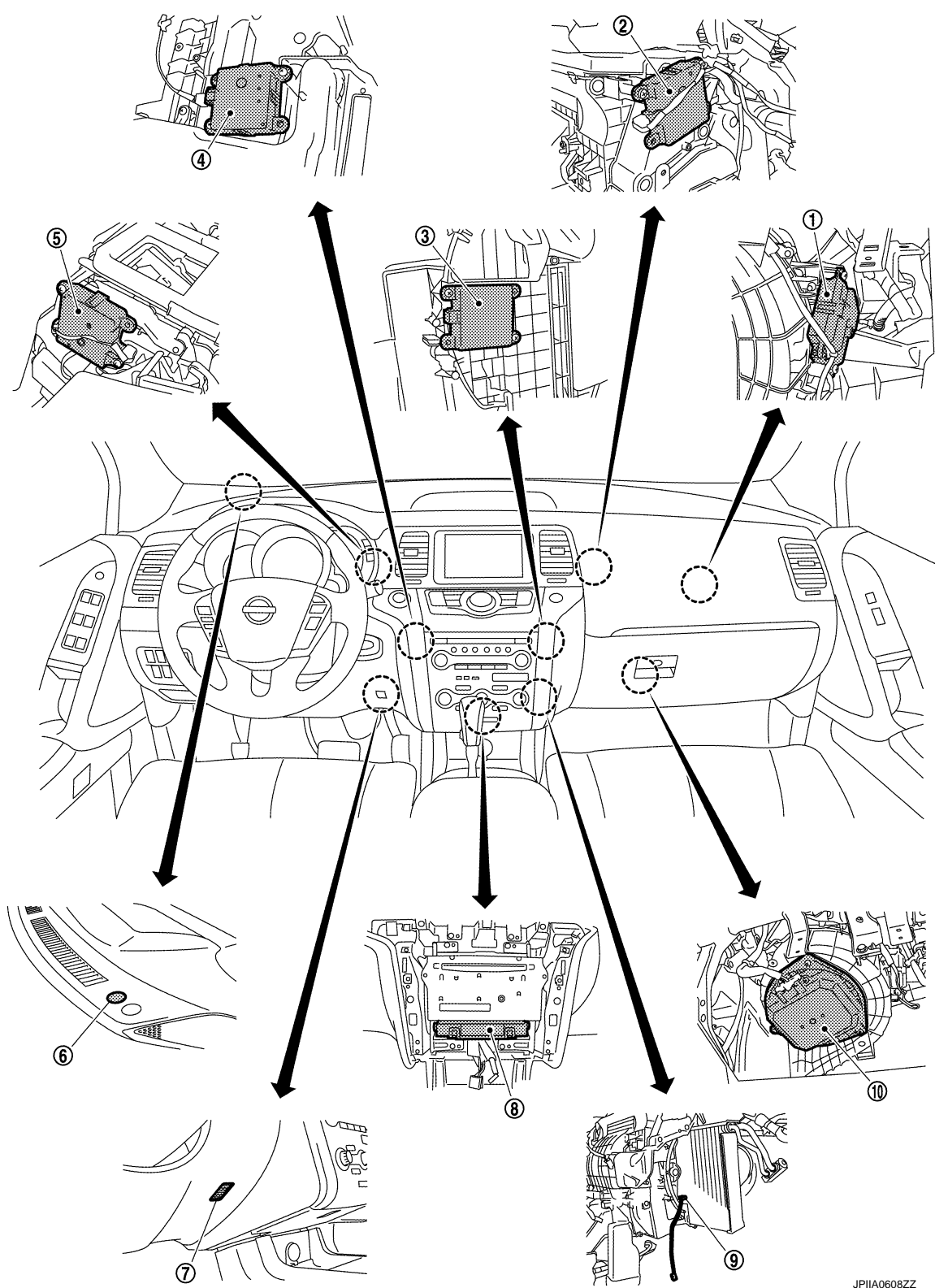

A  
B  
C  
D  
E  
F  
G  
H  
HAC  
J  
K  
L  
M  
N  
O  
P

- |                                     |                                |  |
|-------------------------------------|--------------------------------|--|
| 1. Intake door motor                | 2. Upper ventilator door motor | 3. Air mix door motor (passenger side) |
| 4. Air mix door motor (driver side) | 5. Mode door motor             | 6. Sunload sensor                      |
| 7. In-vehicle sensor                | 8. A/C auto amp.               | 9. Intake sensor                       |
| 10. Blower motor                    |                                |  |

JPIIA0608ZZ

# COMPRESSOR CONTROL FUNCTION

< SYSTEM DESCRIPTION >

[WITHOUT 7 INCH DISPLAY]

## Component's Role

INFOID:000000005514577

Component	Reference
Refrigerant pressure sensor	<a href="#">EC-457. "Description"</a>
Compressor	<a href="#">HAC-73. "Description"</a>
Ambient sensor	<a href="#">HAC-45. "Description"</a>
Intake door motor	<a href="#">HAC-64. "Description"</a>
Upper ventilator door motor	<a href="#">HAC-66. "Description"</a>
Air mix door motor (driver side)	<a href="#">HAC-57. "Description"</a>
Air mix door motor (passenger side)	<a href="#">HAC-59. "Description"</a>
Mode door motor	<a href="#">HAC-61. "Description"</a>
Sunload sensor	<a href="#">HAC-54. "Description"</a>
In-vehicle sensor	<a href="#">HAC-48. "Description"</a>
A/C auto amp.	<a href="#">HAC-76. "A/C AUTO AMP. : Description"</a>
Intake sensor	<a href="#">HAC-51. "Description"</a>
Blower motor	<a href="#">HAC-69. "Description"</a>

# AUTOMATIC AIR CONDITIONER SYSTEM

< SYSTEM DESCRIPTION >

[WITHOUT 7 INCH DISPLAY]

## AUTOMATIC AIR CONDITIONER SYSTEM

### System Diagram

INFOID:000000005514578

### CONTROL SYSTEM

The control system consists of input sensors, switches, the A/C auto amp. (microcomputer) and outputs. The relationship of these components is as shown in the figure below:

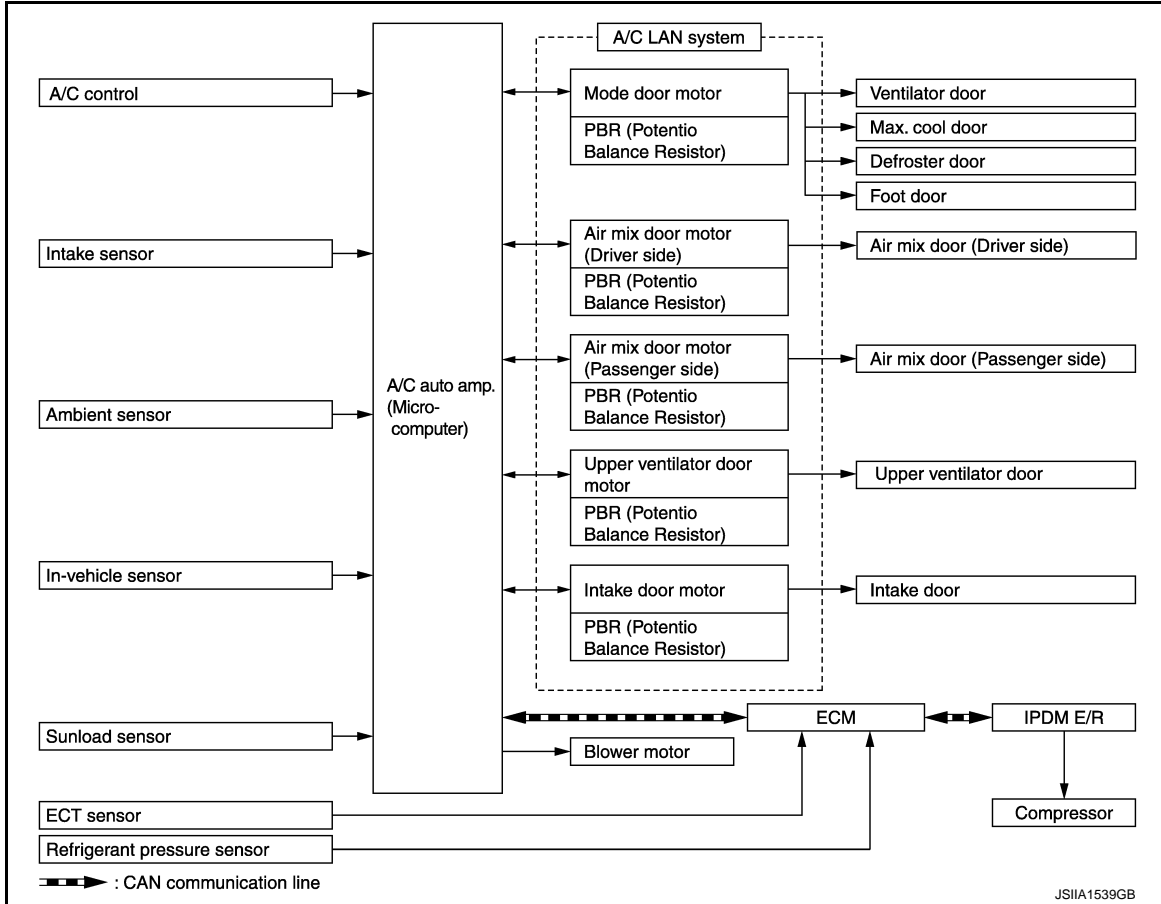

### System Description

INFOID:000000005514579

### CONTROL OPERATION

#### Display

The operation status of the system is displayed on the screen.

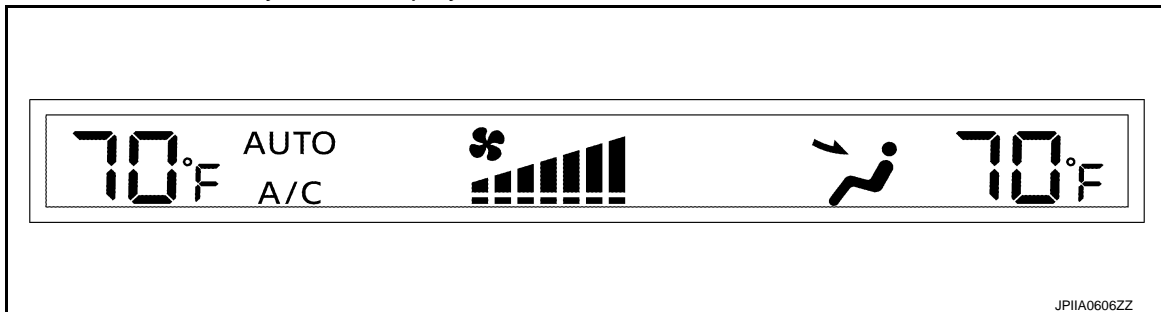





# AUTOMATIC AIR CONDITIONER SYSTEM

< SYSTEM DESCRIPTION >

[WITHOUT 7 INCH DISPLAY]

- When the intake switch indicator is turned OFF, shifting mode position to D/F or DEF, or when compressor is turned from ON to OFF, intake switch is automatically turned OFF (set to FRE mode). REC mode can be re-entered by pressing intake switch again, and then compressor is turned ON. (Except D/F or DEF position)

A

## DUAL Switch

- When the DUAL switch indicator is ON, the driver side and passenger side, temperature can each be set independently.
- When the DUAL switch indicator is OFF, the driver side outlet and setting temperature are applied to both sides.

B

C

D

E

F

G

H

HAC

J

K

L

M

N

O

P

# AUTOMATIC AIR CONDITIONER SYSTEM

< SYSTEM DESCRIPTION >

[WITHOUT 7 INCH DISPLAY]

## DISCHARGE AIR FLOW

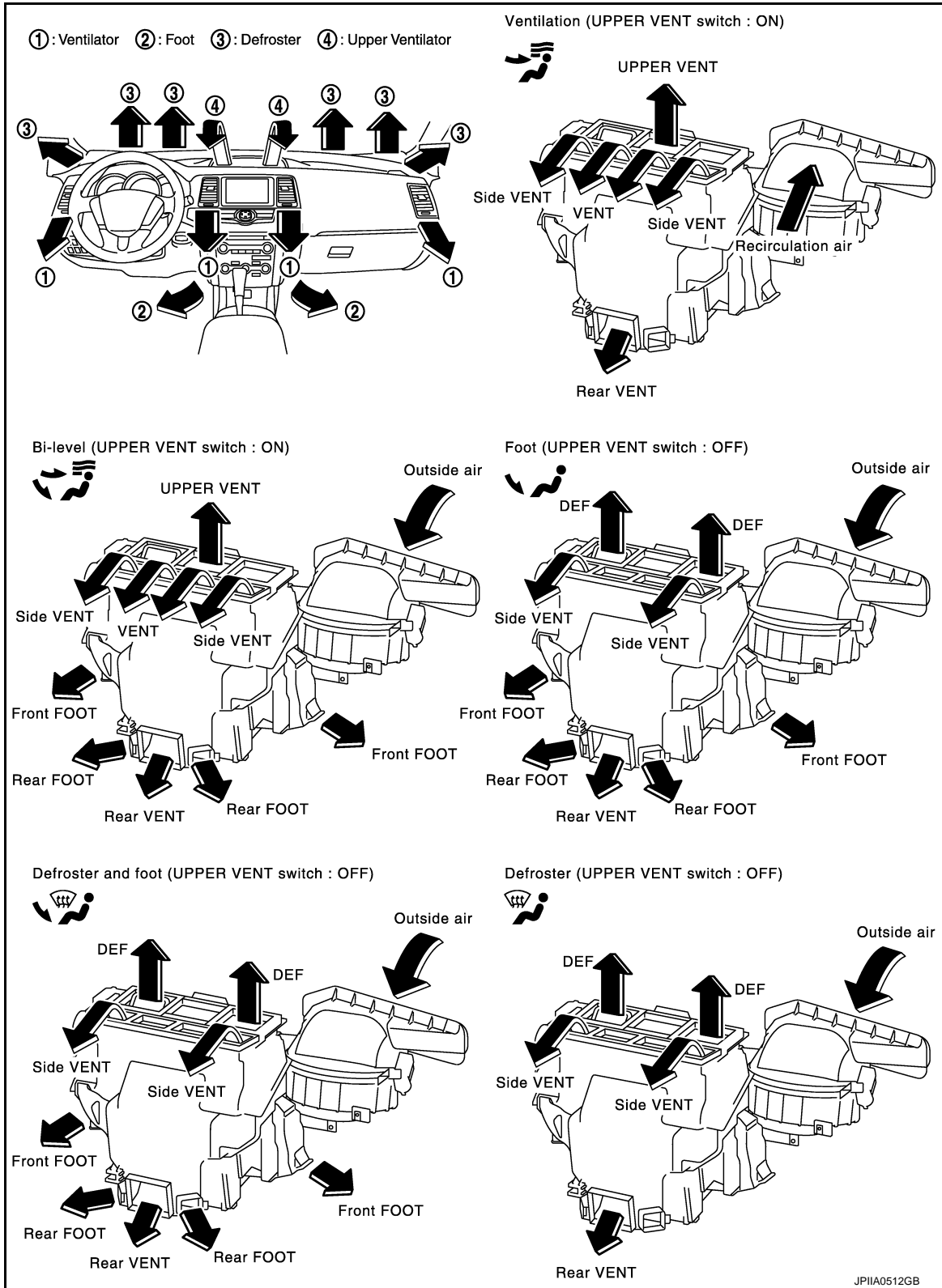

# AUTOMATIC AIR CONDITIONER SYSTEM

< SYSTEM DESCRIPTION >

[WITHOUT 7 INCH DISPLAY]

## AIR DISTRIBUTION

Discharge air flow							
Mode position indication	Condition	Air outlet/distribution					
		VENT			FOOT		DEF
		Front	Upper	Rear	Front	Rear	
	DUAL switch: OFF UPPER VENT switch : ON	81%	8%	11%	—	—	—
		41%	10%	17%	24%	8%	—
		12%	12%	16%	27%	10%	23%
		11%	11%	14%	25%	10%	29%
		11%	11%	12%	—	—	66%

JP1IA0509GB

Discharge air flow							
Mode position indication	Condition	Air outlet/distribution					
		VENT			FOOT		DEF
		Front	Upper	Rear	Front	Rear	
	DUAL switch: OFF UPPER VENT switch : OFF	88%	—	12%	—	—	—
		47%	—	18%	26%	9%	—
		13%	—	17%	33%	12%	25%
		12%	—	16%	28%	12%	32%
		11%	—	15%	—	—	74%

JP1IA0510GB

## SWITCHES AND THEIR CONTROL FUNCTION

A  
B  
C  
D  
E  
F  
G  
H  
HAC  
J  
K  
L  
M  
N  
O  
P

# AUTOMATIC AIR CONDITIONER SYSTEM

< SYSTEM DESCRIPTION >

[WITHOUT 7 INCH DISPLAY]

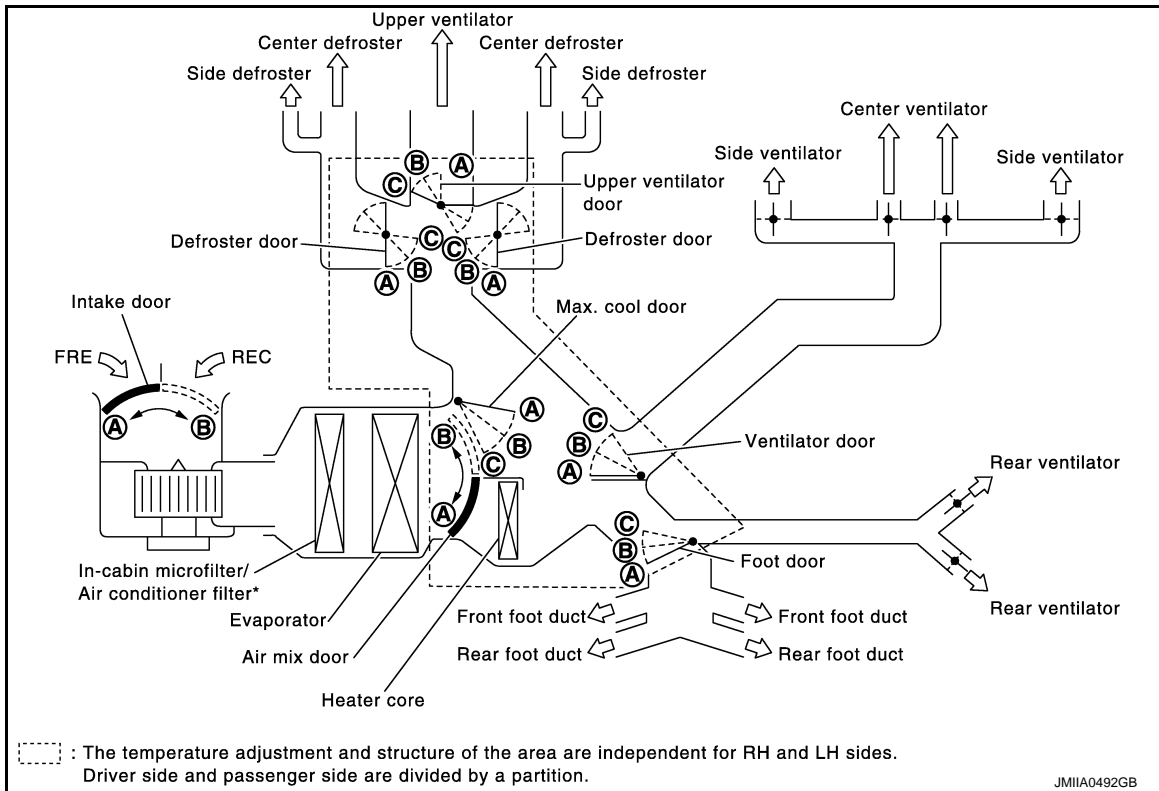

\* : Models for Mexico.

# AUTOMATIC AIR CONDITIONER SYSTEM

< SYSTEM DESCRIPTION >

[WITHOUT 7 INCH DISPLAY]

Switch position			Door position						Air mix door (Driver side)	Air mix door (Passenger side)	
			Ventilator door	Max. cool door	Defroster door	Foot door	Upper ventilator door	Intake door			
AUTO switch	☀		AUTO						AUTO		
MODE switch	VENT	☸	A	A	A	A	—	—			
	B/L	☸	B	B	A	B					
	FOOT	☷	C	B	B	C					
	D/F	☷☸	C	B	B	B					
DEF switch	☸☷	☀	C	C	C	A		B	—	—	
UPPER VENT switch	ON	☸☀	—				A-B	—			
	OFF	☸○					C				
Intake switch	ON	☸☀						A*			
	OFF	☸○						B*			
Temperature control switch (Driver side)	DUAL switch: OFF	18.0°C (60°F)						A			
		18.5°C ⇄ 31.5°C (61°F ⇄ 89°F)						AUTO			
		32.0°C (90°F)						B			
Temperature control switch (Driver side)	DUAL switch: ON	18.0°C (60°F)	—	—	—	—	—	A			
		18.5°C ⇄ 31.5°C (61°F ⇄ 89°F)	—	—	—	—	—	AUTO			
		32.0°C (90°F)	—	—	—	—	—	B			
Temperature control switch (Passenger side)	DUAL switch: ON	18.0°C (60°F)						A			
		18.5°C ⇄ 31.5°C (61°F ⇄ 89°F)						—			AUTO
		32.0°C (90°F)						—			B
ON/OFF switch			C	C	B	C	—	B	—	—	

\*: Inlet status is displayed by indicator when activating automatic control.

## AIR CONDITIONER LAN CONTROL SYSTEM

The LAN (Local Area Network) system consists of the A/C auto amp., the mode door motor, the air mix door motors, the upper ventilator door motor and the intake door motor.

A configuration of these components is as shown in the figure below.

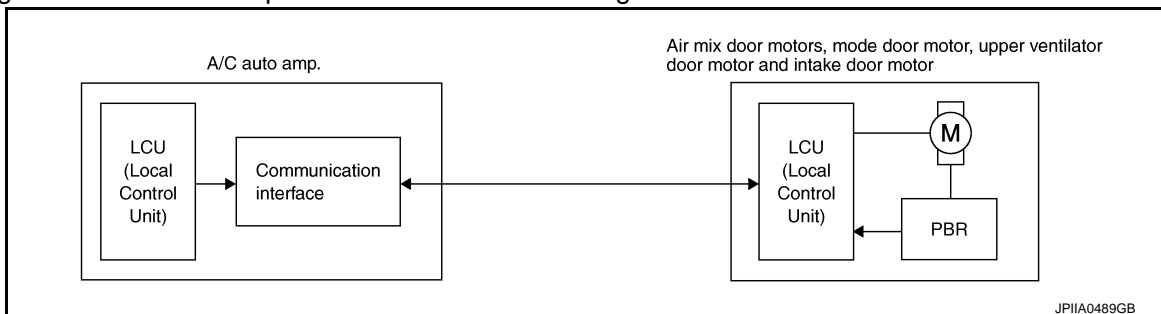

# AUTOMATIC AIR CONDITIONER SYSTEM

< SYSTEM DESCRIPTION >

[WITHOUT 7 INCH DISPLAY]

## SYSTEM CONSTRUCTION

A small network exists between the A/C auto amp., the mode door motor, the air mix door motors, the upper ventilator door motor and the intake door motor. The A/C auto amp. and motors are connected by data transmission lines and motor power supply lines. The LAN network is built through the ground circuits of each door motor.

Addresses, motor opening angle signals, motor stop signals and error checking messages are all transmitted through the data transmission lines connecting the A/C auto amp. and each door motor.

The following functions are contained in LCUs built into the mode door motor, the air mix door motors, the upper ventilator door motor and the intake door motor.

- Address
- Motor opening angle signals
- Data transmission
- Motor stop and drive decision
- Opening angle sensor (PBR function)
- Comparison
- Decision (A/C auto amp. indicated value and motor opening angle comparison)

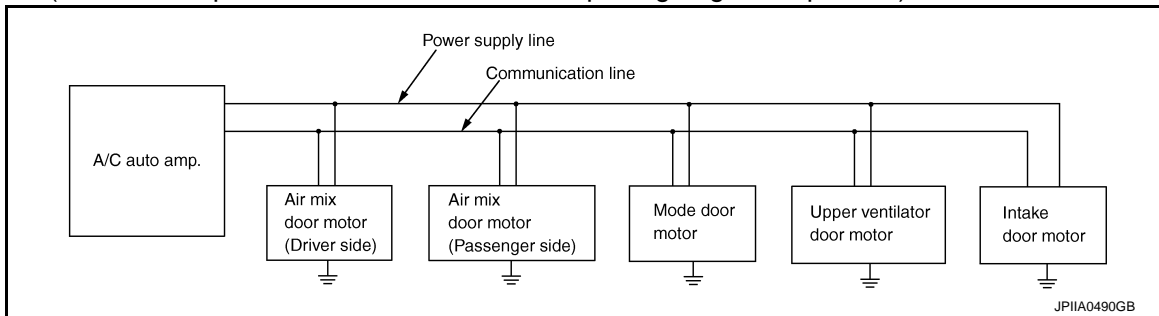

## Operation

The A/C auto amp. receives data from each of the sensors. The A/C auto amp. sends mode door, the air mix door and the intake door opening angle data to the mode door motor LCU, the air mix door motor LCUs, the upper ventilator door motor LCU and the intake door motor LCU.

The mode door motor, the air mix door motors, the upper ventilator door motor and the intake door motor read their respective signals according to the address signal. Opening angle indication signals received from the A/C auto amp. and each of the motor position sensors is compared by the LCUs in each door motor with the existing decision and opening angles. Next, HOT/COLD, DEF/VENT, OPEN/SHUT or FRE/REC operation is selected. The new selection data is returned to the A/C auto amp.

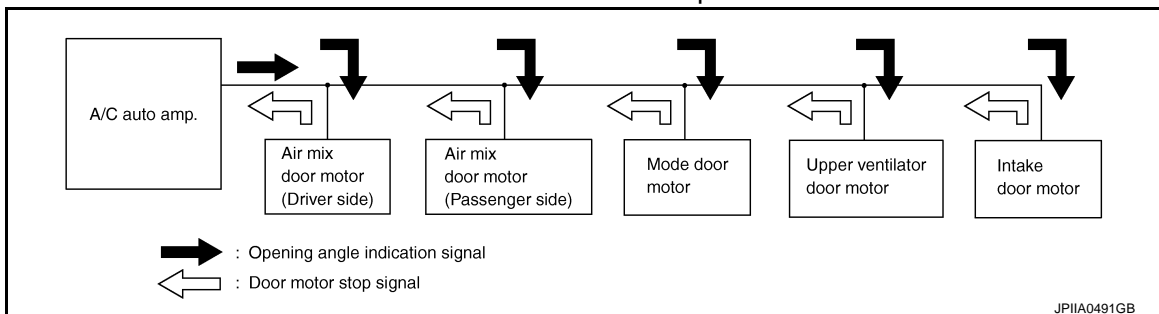

## Transmission Data and Transmission Order

A/C auto amp. data is transmitted consecutively to each of the door motors following the form as shown in the figure below.

### START:

- Initial compulsory signal is sent to each of the door motors.

### ADDRESS:

- Data sent from the A/C auto amp. is selected according to data-based decisions made by the mode door motor, the air mix door motors, the upper ventilator door motor and the intake door motor.
- If the addresses are identical, the opening angle data and error check signals are received by the door motor LCUs. The LCUs then make the appropriate error decision. If the opening angle data has no error, door control begins.
- If an error exists, the received data is rejected and the corrected data received. Finally, door control is based upon the corrected opening angle data.

# AUTOMATIC AIR CONDITIONER SYSTEM

[WITHOUT 7 INCH DISPLAY]

## < SYSTEM DESCRIPTION >

### OPENING ANGLE:

- Data that shows the indicated door opening angle of each door motor.

### ERROR CHECK:

- In this procedure, transmitted and received data is checked for errors. Error data is then compiled. The error check prevents corrupted data from being used by the mode door motor, the air mix door motors, the upper ventilator door motor and the intake door motor. Error data can be related to the following symptoms.
  - Malfunction of electrical frequency
  - Poor electrical connections
  - Signal leakage from transmission lines
  - Signal level fluctuation

### STOP SIGNAL:

- At the end of each transmission, a stop operation, in-operation, or internal malfunction message is delivered to the A/C auto amp. This completes one data transmission and control cycle.

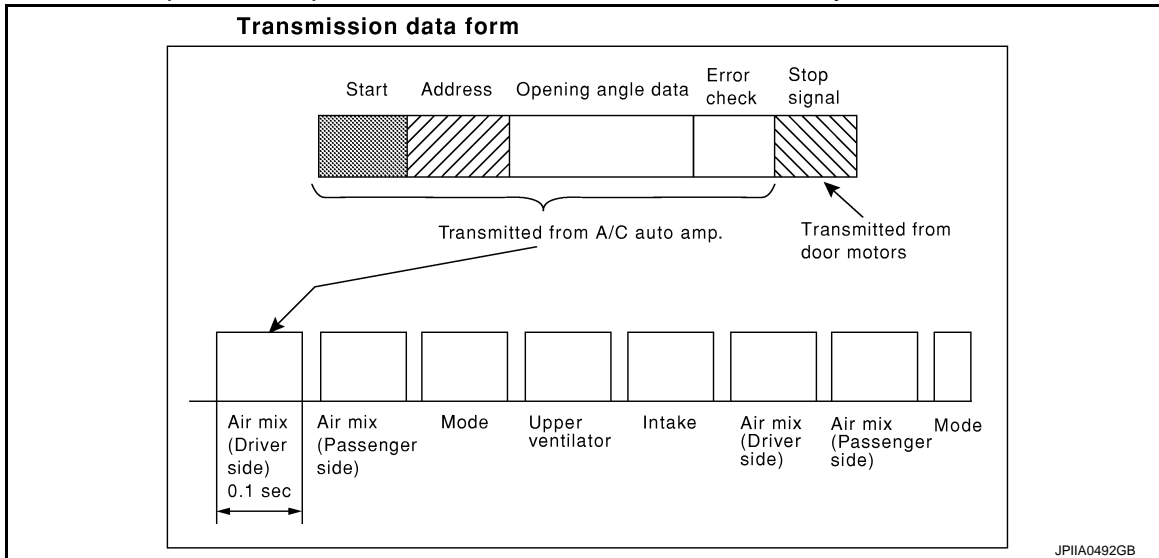

## Component Part Location

INFOID:000000005514580

## ENGINE COMPARTMENT

A  
B  
C  
D  
E  
F  
G  
H  
J  
K  
L  
M  
N  
O  
P

HAC

# AUTOMATIC AIR CONDITIONER SYSTEM

< SYSTEM DESCRIPTION >

[WITHOUT 7 INCH DISPLAY]

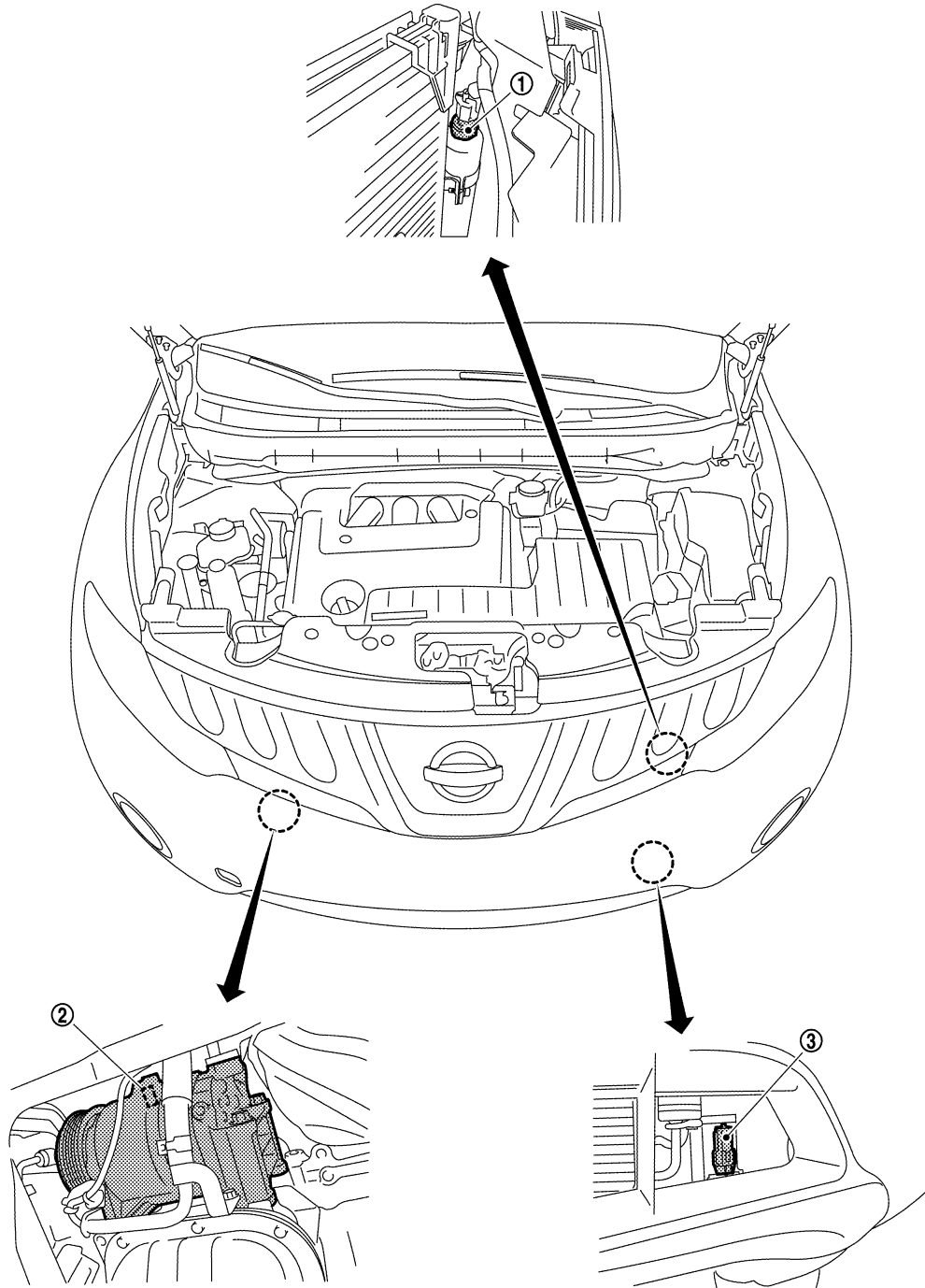

JPIIA0607ZZ

1. Refrigerant pressure sensor

2. Compressor (magnet clutch)

3. Ambient sensor

PASSENGER COMPARTMENT



# AUTOMATIC AIR CONDITIONER SYSTEM

< SYSTEM DESCRIPTION >

[WITHOUT 7 INCH DISPLAY]

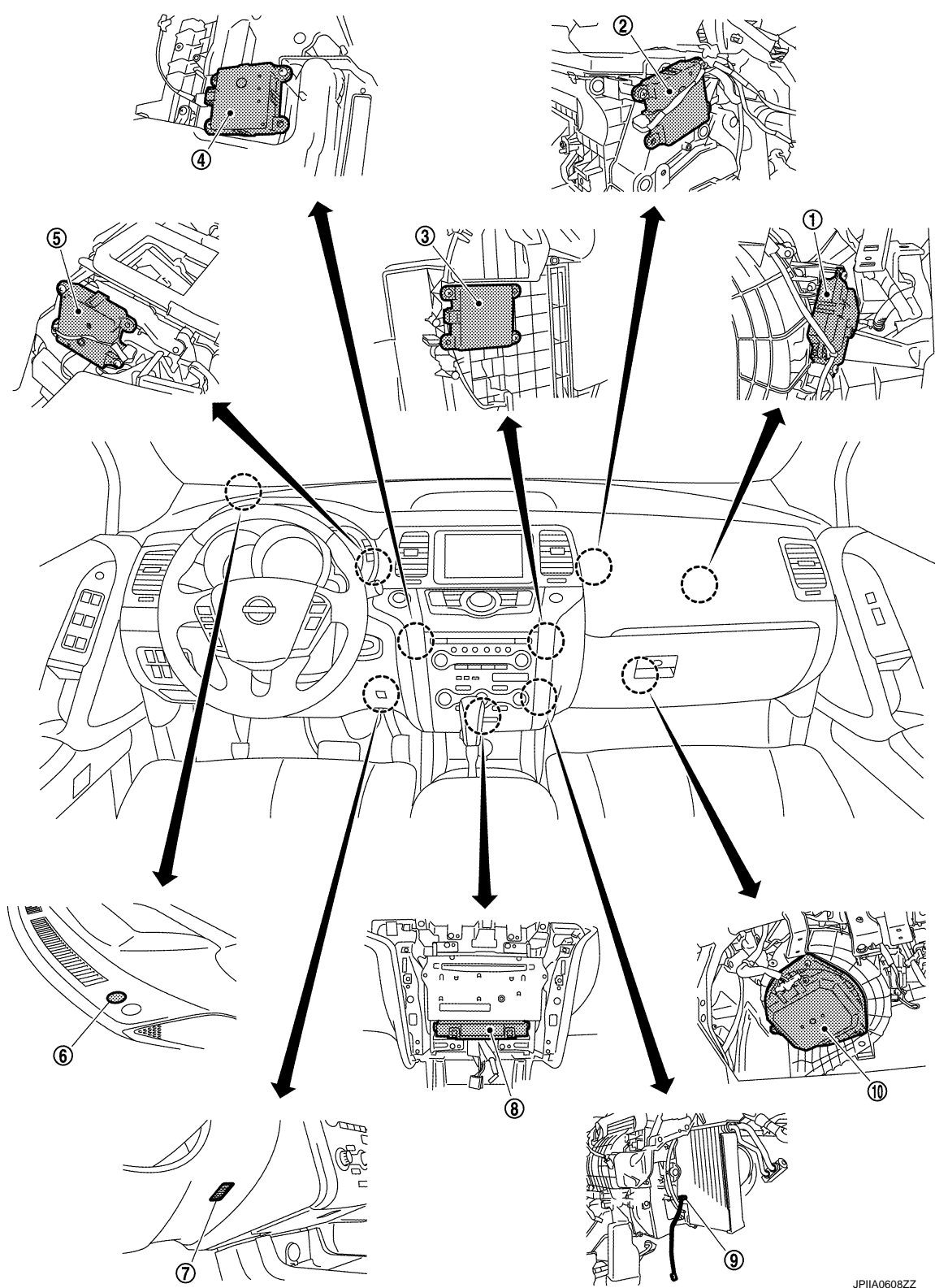

A  
B  
C  
D  
E  
F  
G  
H  
HAC  
J  
K  
L  
M  
N  
O  
P

- |                                     |                                |  |
|-------------------------------------|--------------------------------|--|
| 1. Intake door motor                | 2. Upper ventilator door motor | 3. Air mix door motor (passenger side) |
| 4. Air mix door motor (driver side) | 5. Mode door motor             | 6. Sunload sensor                      |
| 7. In-vehicle sensor                | 8. A/C auto amp.               | 9. Intake sensor                       |
| 10. Blower motor                    |                                |  |

JPIIA0608ZZ

# AUTOMATIC AIR CONDITIONER SYSTEM

< SYSTEM DESCRIPTION >

[WITHOUT 7 INCH DISPLAY]

## Component Description

INFOID:000000005514581

Component	Reference
Refrigerant pressure sensor	<a href="#">EC-457. "Description"</a>
Compressor	<a href="#">HAC-73. "Description"</a>
Ambient sensor	<a href="#">HAC-45. "Description"</a>
Intake door motor	<a href="#">HAC-64. "Description"</a>
Upper ventilator door motor	<a href="#">HAC-66. "Description"</a>
Air mix door motor (driver side)	<a href="#">HAC-57. "Description"</a>
Air mix door motor (passenger side)	<a href="#">HAC-59. "Description"</a>
Mode door motor	<a href="#">HAC-61. "Description"</a>
Sunload sensor	<a href="#">HAC-54. "Description"</a>
In-vehicle sensor	<a href="#">HAC-48. "Description"</a>
A/C auto amp.	<a href="#">HAC-76. "A/C AUTO AMP. : Description"</a>
Intake sensor	<a href="#">HAC-51. "Description"</a>
Blower motor	<a href="#">HAC-69. "Description"</a>

# MODE DOOR CONTROL SYSTEM

< SYSTEM DESCRIPTION >

[WITHOUT 7 INCH DISPLAY]

## MODE DOOR CONTROL SYSTEM

### System Diagram

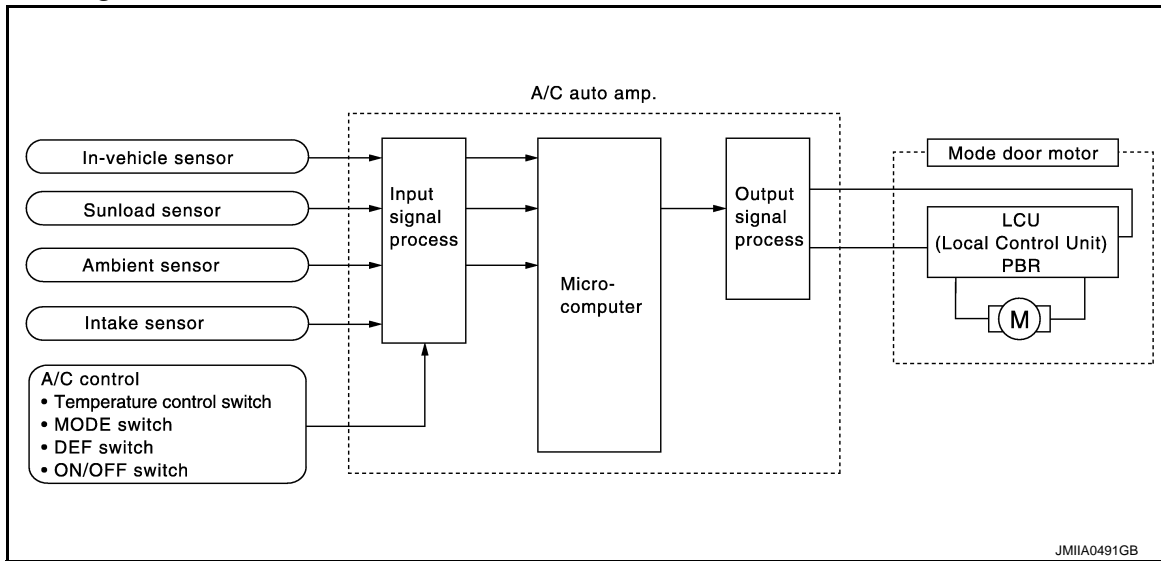

### System Description

The mode door is automatically controlled by the temperature setting, ambient temperature, in-vehicle temperature, intake temperature and amount of sunload.

### SYSTEM OPERATION

- The A/C auto amp. receives data from each of the sensors.
- The A/C auto amp. sends the air mix door, the mode door, the upper ventilator door and the intake door opening angle data to the air mix door motor LCU(s), the mode door motor LCU, the upper ventilator door motor LCU and the intake door motor LCU.
- The air mix door motor(s), the mode door motor, the upper ventilator door motor and the intake door motor read their respective signals according to the address signal. Opening angle indication signals received from the A/C auto amp. and each of the motor position sensors are compared by the LCUs in each door motor with the existing decision and opening angles.
- Next, HOT/COLD, DEF/VENT, OPEN/SHUT or FRE/REC operations is selected. The newly selected data is returned to the A/C auto amp.

### Door Motor Circuit

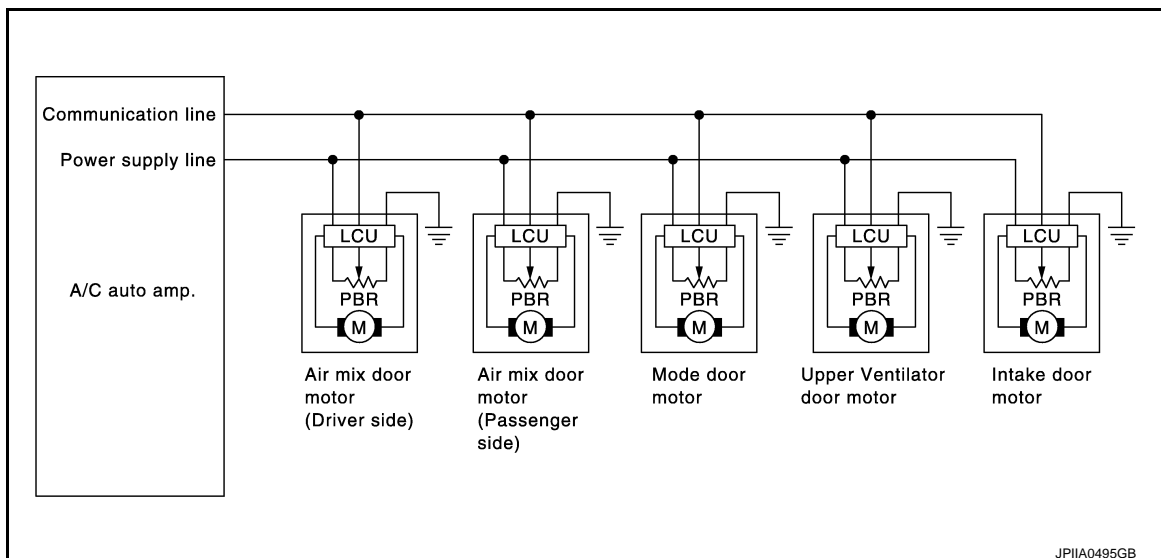

### Mode Door Control Specification

# MODE DOOR CONTROL SYSTEM

< SYSTEM DESCRIPTION >

[WITHOUT 7 INCH DISPLAY]

Mode position can be selected manually by pressing the MODE switch or the DEF switch on the A/C control. This enables to fix a mode position. Pressing the AUTO switch allows automatic control by the A/C auto amp. During the automatic control of a mode position, a mode door position (VENT, B/L, FOOT, or D/F) is selected based on a target the air mix door opening angle and sunload depending on the temperature calculated by the A/C auto amp. In addition, the D/F is selected to prevent windshield fogging only when ambient temperature is extremely low with mode position the FOOT.

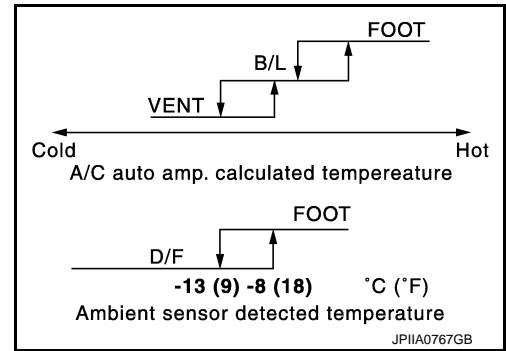

# UPPER VENTILATOR DOOR CONTROL SYSTEM

< SYSTEM DESCRIPTION >

[WITHOUT 7 INCH DISPLAY]

## UPPER VENTILATOR DOOR CONTROL SYSTEM

### System Diagram

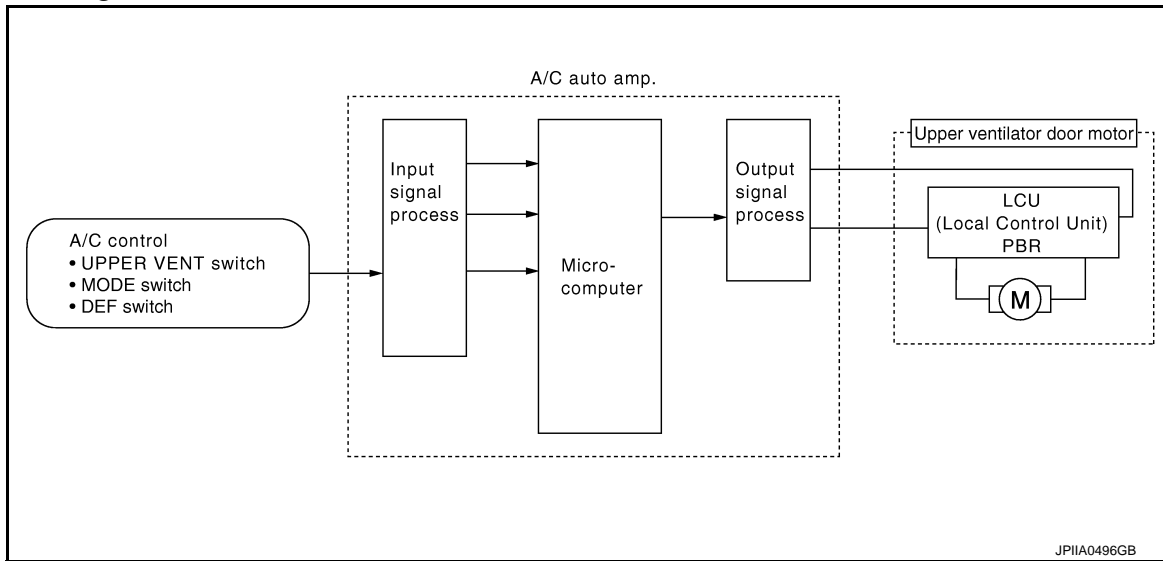

### System Description

INFOID:000000005514585

The upper ventilator door motor is attached to the heater & cooling unit assembly. The upper ventilator door motor operates by the UPPER VENT switch ON/OFF. Motor rotation is conveyed to a rod which activates the upper ventilator door.

### SYSTEM OPERATION

- The A/C auto amp. receives data from each of the sensors.
- The A/C auto amp. sends air mix door, the mode door, the upper ventilator door and the intake door opening angle data to the air mix door motor LCU(s), the mode door motor LCU, the upper ventilator door motor LCU and the intake door motor LCU.
- The air mix door motor(s), the mode door motor, the upper ventilator door motor and the intake door motor read their respective signals according to the address signal. Opening angle indication signals received from the A/C auto amp. and each of the motor position sensors are compared by the LCUs in each door motor with the existing decision and opening angles.
- Next, HOT/COLD, DEF/VENT, OPEN/SHUT or FRE/REC operations is selected. The newly selected data is returned to the A/C auto amp.

### Door Motor Circuit

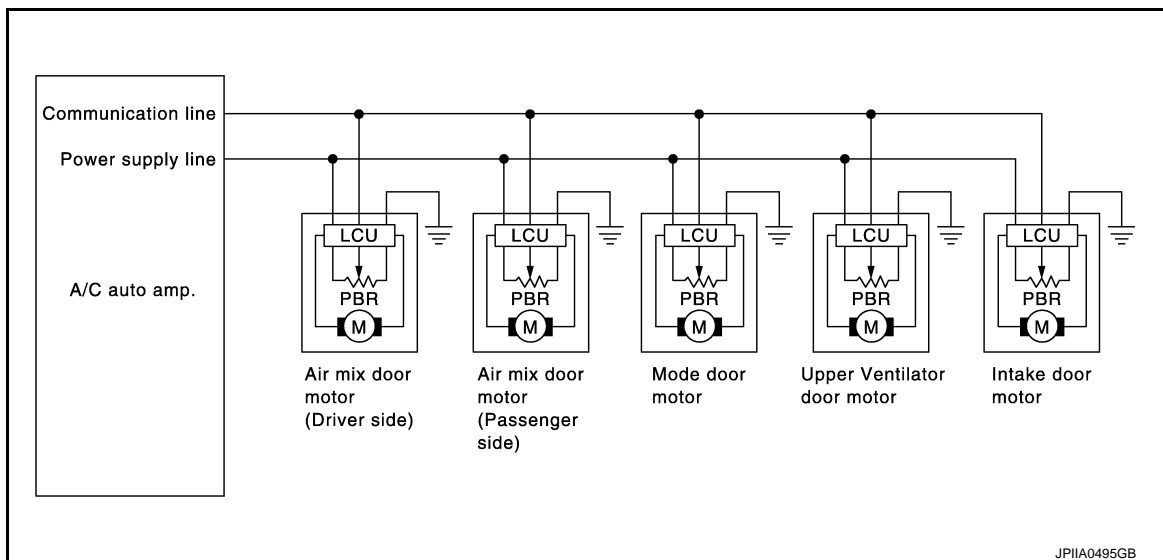

Upper Ventilator Specification

Revision: 2009 September

HAC-29

2010 Murano

# UPPER VENTILATOR DOOR CONTROL SYSTEM

< SYSTEM DESCRIPTION >

[WITHOUT 7 INCH DISPLAY]

UPPER VENT switch	MODE position	Upper ventilator door position
OFF	—	Close
ON	VENT or B/L	Open (Fully-open)
ON	FOOT or D/F	Open (Intermediate)
ON	DEF	Close

# AIR MIX DOOR CONTROL SYSTEM

< SYSTEM DESCRIPTION >

[WITHOUT 7 INCH DISPLAY]

## AIR MIX DOOR CONTROL SYSTEM

### System Diagram

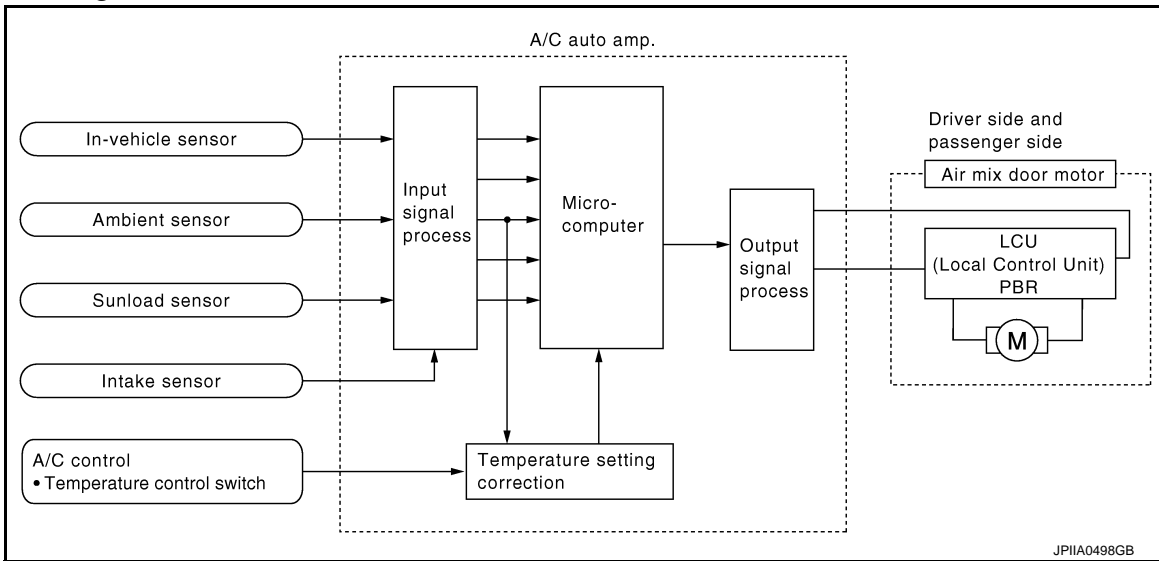

### System Description

INFOID:000000005514587

The air mix doors are automatically controlled so that in-vehicle temperature is maintained at a predetermined value by the temperature setting, ambient temperature, intake temperature and amount of sunload.

### SYSTEM OPERATION

- The A/C auto amp. receives data from each of the sensors.
- The A/C auto amp. sends air mix door, the mode door, the upper ventilator door and the intake door opening angle data to the air mix door motor LCU(s), the mode door motor LCU, the upper ventilator door motor LCU and the intake door motor LCU.
- The air mix door motor(s), the mode door motor, the upper ventilator door motor and the intake door motor read their respective signals according to the address signal. Opening angle indication signals received from the A/C auto amp. and each of the motor position sensors are compared by the LCUs in each door motor with the existing decision and opening angles.
- Next, HOT/COLD, DEF/VENT, OPEN/SHUT or FRE/REC operation is selected. The newly selected data is returned to the A/C auto amp.

### Door Motor Circuit

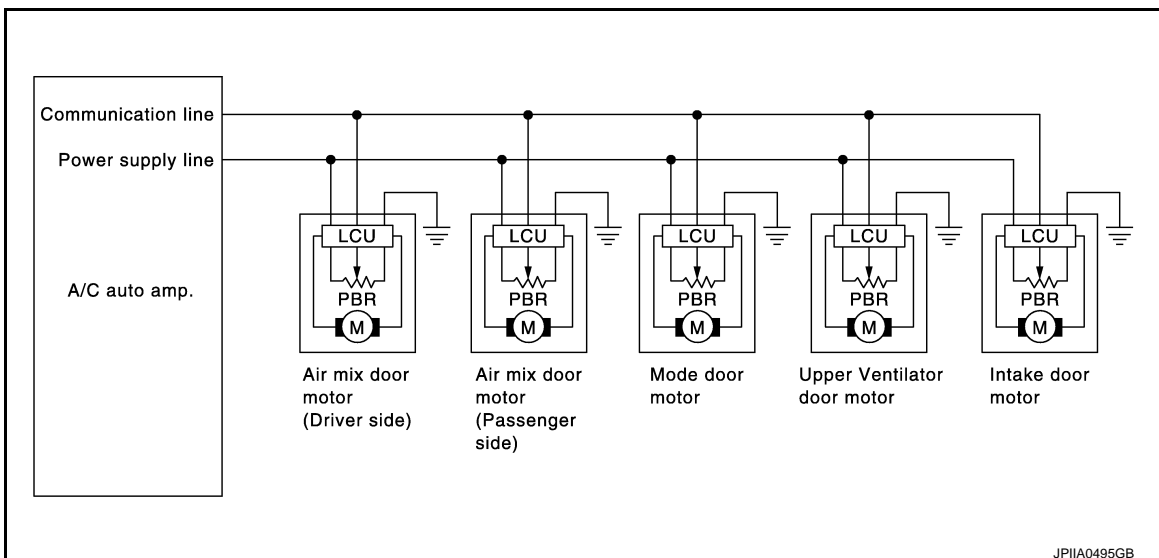

### Air Mix Door Control Specification

# AIR MIX DOOR CONTROL SYSTEM

## < SYSTEM DESCRIPTION >

[WITHOUT 7 INCH DISPLAY]

When ignition switch is ON, the A/C auto amp. continuously and automatically controls temperatures regardless of air conditioner operational condition. When setting a target temperature with the temperature control switch, the A/C auto amp. corrects the set temperature and decides a target air mix door opening angle. The A/C auto amp. controls air mix door according to the target air mix door opening angle and current air mix door opening angle, keeping an optimum air mix door opening angle. When the temperature is set at 18°C (60°F), air mix door is set on full cold, and when the temperature is set at 32°C (90°F), it is set to full hot.

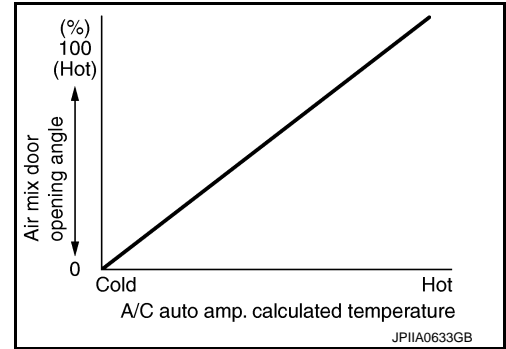



# INTAKE DOOR CONTROL SYSTEM

< SYSTEM DESCRIPTION >

[WITHOUT 7 INCH DISPLAY]

## INTAKE DOOR CONTROL SYSTEM

### System Diagram

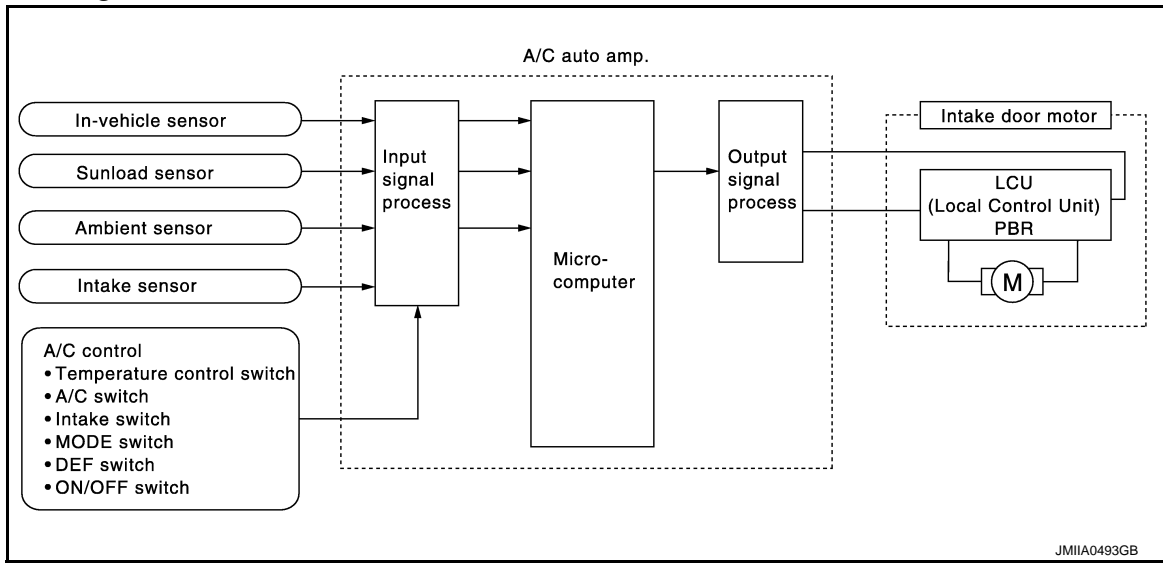

### System Description

INFOID:000000005514589

The intake doors are automatically controlled by the temperature setting, ambient temperature, in-vehicle temperature, intake temperature, amount of sunload and ON/OFF operation of the compressor.

### SYSTEM OPERATION

The intake door control judges intake door position based on the ambient temperature, the intake air temperature and the in-vehicle temperature. When in shifting mode position D/F, if the DEF or ON/OFF switches are pressed, or when the A/C switch is OFF, the A/C auto amp. sets the intake door to the FRE position.

### Door Motor Circuit

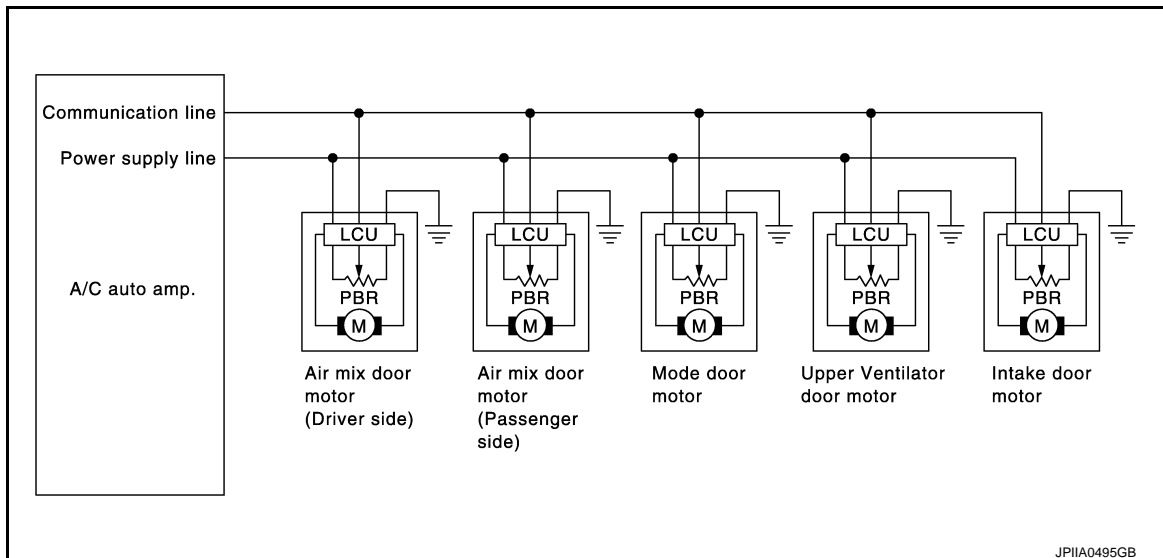

### Intake Door Control Specification

# INTAKE DOOR CONTROL SYSTEM

[WITHOUT 7 INCH DISPLAY]

## < SYSTEM DESCRIPTION >

Intake door position is basically set to the FRE when the FRE indicator of the DEF switch and the intake switch turn ON, and set on the REC when the REC indicator of intake switch turns ON.

The intake door automatic control selects the FRE, the 20%FRE, or the REC depending on the target air mix door opening angle, based on in-vehicle temperature, ambient temperature, and sunload.

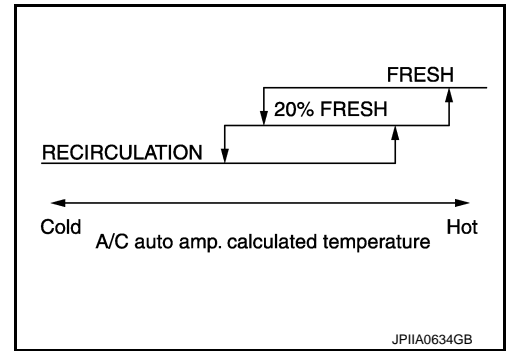

# BLOWER MOTOR CONTROL SYSTEM

< SYSTEM DESCRIPTION >

[WITHOUT 7 INCH DISPLAY]

## BLOWER MOTOR CONTROL SYSTEM

### System Diagram

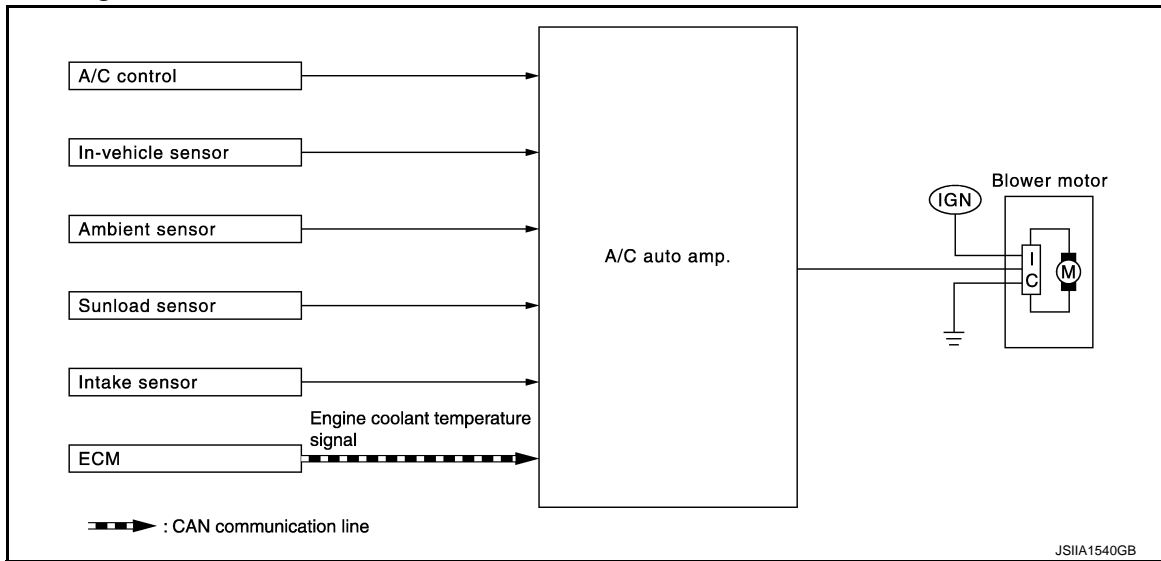

### System Description

INFOID:000000005514591

Blower speed is automatically controlled by the temperature setting, ambient temperature, in-vehicle temperature, intake temperature, amount of sunload and air mix door position.

By pressing the AUTO switch, the blower motor starts to gradually increase air flow volume.

When engine coolant temperature is low, the blower motor operation is delayed to prevent cool air from flowing.

### SYSTEM OPERATION

#### System operation

- For air flow, the manual selection (1-7) with the fan control dial has priority.
- If the AUTO switch is pressed or if the DEF switch is pressed while in the OFF condition, it changes to the automatic control by A/C auto amp.
- When increasing the air flow, it changes the duty ratio of the blower motor drive signal to prevent the air flow from suddenly increasing.
- There are the following types of air flow control: starting air flow control, starting air flow control at low coolant temperature, starting air flow control at high in-vehicle temperature, and air flow control at actuator operation in addition to manual control, normal automatic air flow control.

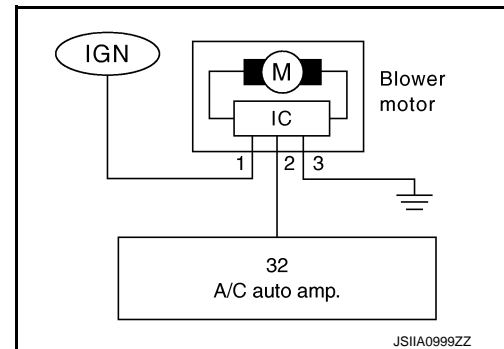

#### Normal automatic air flow control

- When the target temperature is set by the temperature control switch of A/C control, the A/C auto amp. performs the calculation and decides the target according to the signal from each sensor.
- The A/C auto amp. changes the duty ratio of blower motor drive signal and controls the air flow continuously so that the air flow becomes the target air flow.
- The minimum air flow will change according to the sunload when the air discharge outlet is VENT or B/L.

# BLOWER MOTOR CONTROL SYSTEM

< SYSTEM DESCRIPTION >

[WITHOUT 7 INCH DISPLAY]

Fan Speed Control Specification

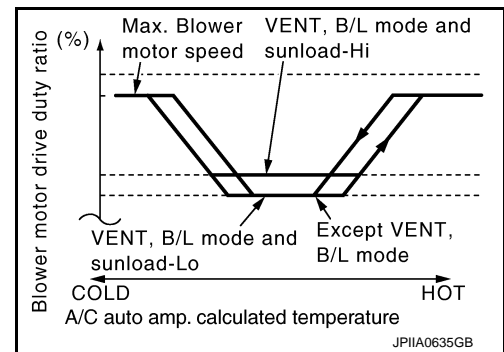

## Starting air flow control

- When starting the automatic control of air flow, the system gradually increases the duty ratio of the blower motor drive signal to prevent too much air from blowing.
- The time period from when the air flow changes from LO to HI is approximately 8 seconds.
- It becomes the starting air flow control at low coolant temperature according to the calculation result of the A/C auto amp. and engine coolant temperature [approximately 58°C (136°F) or less] during the automatic air flow control.
- Do not perform the starting air flow control when the air discharge outlet is set to DEF.

## Starting Fan Speed Control

### Start up from COLD SOAK Condition (Automatic mode)

In cold start up condition where the engine coolant temperature is below 58°C (136°F), the blower does not operate for a short period of time (up to 150 seconds). The exact start delay time varies depending on the ambient temperature and engine coolant temperature.

In the most extreme case (very low ambient temperature) the blower start delay is 150 seconds as described above. After this delay, the blower will operate at low speed until the engine coolant temperature rises above 58°C (136°F), and then the blower speed increases to the objective speed.

### Start up from usual or HOT SOAK Condition (Automatic mode)

The blower will begin operation momentarily after the AUTO switch is pressed. The blower speed rises gradually to the objective speed over a time period of 3 seconds or less (actual time depends on the objective blower speed).

# MAGNET CLUTCH CONTROL SYSTEM

< SYSTEM DESCRIPTION >

[WITHOUT 7 INCH DISPLAY]

## MAGNET CLUTCH CONTROL SYSTEM

### System Diagram

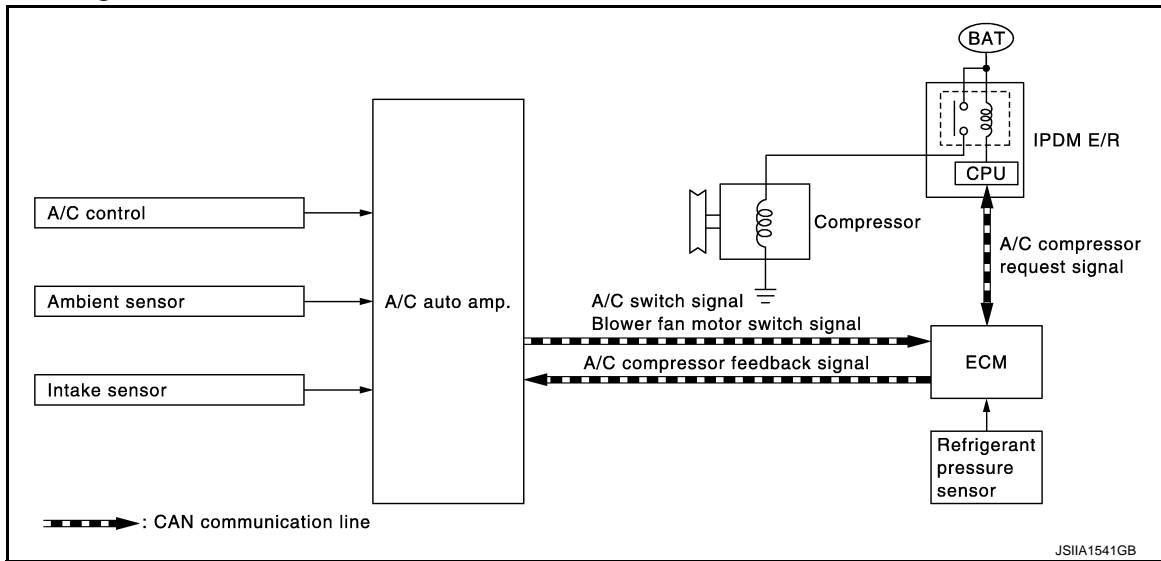

### System Description

INFOID:00000000514593

The A/C auto amp. controls compressor operation by ambient temperature, intake air temperature and signal from ECM.

#### SYSTEM OPERATION

When the A/C switch, the AUTO switch, or the DEF switch is pressed, or when shifting mode position D/F, A/C auto amp. transmit the A/C switch signal and blower fan motor switch signal to the ECM, via CAN communication.

ECM judges whether compressor can be turned ON, based on each sensor status (refrigerant-pressure sensor signal, throttle angle, etc.). If the ECM judges that the compressor can be turned ON, it sends A/C compressor request signal to the IPDM E/R, via CAN communication.

Upon receipt of A/C compressor request signal from the ECM, the IPDM E/R turns the A/C relay ON to operate the compressor.

When sending A/C compressor request signal to the IPDM E/R via CAN communication line, the ECM simultaneously sends A/C compressor feedback signal to A/C auto amp. via CAN communication line.

The ECM sends A/C compressor feedback signal to A/C auto amp., then, uses input A/C compressor feedback signal to control air inlet.

#### Compressor Protection Control

The ECM makes the A/C relay turn OFF and stops the compressor when pressure on the high-pressure side detected by the refrigerant pressure sensor is over approximately 3,119 kPa (31.8 kg/cm<sup>2</sup>, 452 psi), or below approximately 118 kPa (1.2 kg/cm<sup>2</sup>, 17 psi).

#### Low Temperature Protection Control

Turn the A/C relay to OFF and stop the compressor by the signal from the A/C auto amp according to the evaporator passing air temperature detected by the intake sensor and the ambient temperature detected by the ambient sensor.

## CAN COMMUNICATION SYSTEM

---

### System Description

INFOID:00000000514594

CAN (Controller Area Network) is a serial communication line for real time application. It is an on-vehicle multiplex communication line with high data communication speed and excellent error detection ability. Many electronic control units are equipped onto each vehicle, and each control unit shares information and links with other control units during operation (not independent). In CAN communication, control units are connected with 2 communication lines (CAN-H line, CAN-L line) allowing a high rate of information transmission with less wiring. Each control unit transmits/receives data but selectively reads required data only. For details, refer to [LAN-27. "CAN System Specification Chart"](#).

# DIAGNOSIS SYSTEM (HVAC)

< SYSTEM DESCRIPTION >

[WITHOUT 7 INCH DISPLAY]

## DIAGNOSIS SYSTEM (HVAC)

### CONSULT-III Function

INFOID:00000000514595

CONSULT-III can display each diagnosis item using the diagnosis test modes shown as per the following.

#### CONSULT-III application items

Diagnosis mode	Description
ECU Identification	Displays the A/C auto amp. number.
Self Diagnostic Result	Displays the diagnosis results judged by A/C auto amp.
Data Monitor	Displays A/C auto amp. input/output data in real time.
Active Test	The signals used to activate each device are forcibly supplied from A/C auto amp.
Work Support	Changes the setting for each system function. <ul style="list-style-type: none"> <li>• Temperature setting trimmer</li> <li>• Inlet port memory function (FRE)</li> <li>• Inlet port memory function (REC)</li> <li>• Foot position setting trimmer</li> </ul>

### SELF DIAGNOSTIC RESULT

Refer to [HAC-106, "DTC Index"](#).

#### Display Item List

DTC	Items (CONSULT-III screen terms)	Diagnostic item is detected when...	Possible cause
U1000	CAN COMM CIRCUIT	When A/C auto amp. is not transmitting or receiving CAN communication signal for 2 or more seconds.	CAN communication system
U1010	CONTROL UNIT (CAN)	When detecting error during the initial diagnosis of CAN controller of A/C auto amp.	A/C auto amp.
B257B	AMB TEMP SEN SHORT	Detected temperature at ambient sensor $-44^{\circ}\text{C}$ ( $-47^{\circ}\text{F}$ ) or less	<ul style="list-style-type: none"> <li>• Ambient sensor</li> <li>• A/C auto amp.</li> <li>• Harness and connector</li> </ul>
B257C	AMB TEMP SEN OPEN	Detected temperature at ambient sensor $100^{\circ}\text{C}$ ( $212^{\circ}\text{F}$ ) or more	(Ambient sensor circuit is open, or there is a short in the circuit)
B2578	IN CAR SEN SHORT	Detected temperature at in-vehicle sensor $-44^{\circ}\text{C}$ ( $-47^{\circ}\text{F}$ ) or less	<ul style="list-style-type: none"> <li>• In-vehicle sensor</li> <li>• A/C auto amp.</li> <li>• Harness and connector</li> </ul>
B2579	IN CAR SEN OPEN	Detected temperature at in-vehicle sensor $100^{\circ}\text{C}$ ( $212^{\circ}\text{F}$ ) or more	(In-vehicle sensor circuit is open, or there is a short in the circuit)
B2581	EVAP TEMP SEN SHORT	Detected temperature at intake sensor $-33^{\circ}\text{C}$ ( $-27^{\circ}\text{F}$ ) or less	<ul style="list-style-type: none"> <li>• Intake sensor</li> <li>• A/C auto amp.</li> <li>• Harness and connector</li> </ul>
B2582	EVAP TEMP SEN OPEN	Detected temperature at intake sensor $69^{\circ}\text{C}$ ( $156^{\circ}\text{F}$ ) or more	(Intake sensor circuit is open, or there is a short in the circuit)
B2630*	SUNLOAD SEN SHORT	Detected calorie at sunload sensor $64.7 \text{ w/m}^2$ ( $56 \text{ kcal/m}^2\cdot\text{h}$ ) or less	<ul style="list-style-type: none"> <li>• Sunload sensor</li> <li>• A/C auto amp.</li> <li>• Harness and connector</li> </ul>
B2631*	SUNLOAD SEN OPEN	Detected calorie at sunload sensor $2832 \text{ w/m}^2$ ( $2436 \text{ kcal/m}^2\cdot\text{h}$ ) or more	(Sunload sensor circuit is open, or there is a short in the circuit)
B2632	DR AIRMIX ACTR SHORT	Air mix door PBR (driver side) position 5% or less	<ul style="list-style-type: none"> <li>• Air mix door motor (driver side)</li> <li>• A/C auto amp.</li> <li>• Harness and connector</li> </ul>
B2633	DR AIRMIX ACTR OPEN	Air mix door PBR (driver side) position 95% or more	(CAN communication line is open or shorted) (Air mix door motor is open or shorted)

# DIAGNOSIS SYSTEM (HVAC)

< SYSTEM DESCRIPTION >

[WITHOUT 7 INCH DISPLAY]

DTC	Items (CONSULT-III screen terms)	Diagnostic item is detected when...	Possible cause
B2634	PASS AIRMIX ACTR SHORT	Air mix door PBR (passenger side) position 5% or less	<ul style="list-style-type: none"> <li>Air mix door motor (passenger side)</li> <li>A/C auto amp.</li> <li>Harness and connector (CAN communication line is open or shorted)</li> <li>(Air mix door motor is open or shorted)</li> </ul>
B2635	PASS AIRMIX ACTR OPEN	Air mix door PBR (passenger side) position 95% or more	<ul style="list-style-type: none"> <li>Mode door motor</li> <li>A/C auto amp.</li> <li>Harness and connector (CAN communication line is open or shorted)</li> <li>(Mode door motor is open or shorted)</li> </ul>
B2636	DR VENT DOOR FAIL	When the malfunctioning door position is detected at VENT position	<ul style="list-style-type: none"> <li>Mode door motor</li> <li>A/C auto amp.</li> <li>Harness and connector (CAN communication line is open or shorted)</li> <li>(Mode door motor is open or shorted)</li> </ul>
B2637	DR B/L DOOR FAIL	When the malfunctioning door position is detected at B/L position	
B2638	DR D/F1 DOOR FAIL	When the malfunctioning door position is detected at FOOT position	
B2639	DR DEF DOOR FAIL	When the malfunctioning door position is detected at DEF position	
B263D	FRE DOOR FAIL	When the malfunctioning intake door position is detected at FRE position	<ul style="list-style-type: none"> <li>Intake door motor</li> <li>A/C auto amp.</li> <li>Harness and connector (CAN communication line is open or shorted)</li> <li>(Intake door motor is open or shorted)</li> </ul>
B263E	20P FRE DOOR FAIL	When the malfunctioning intake door position is detected at 20%FRE position	
B263F	REC DOOR FAIL	When the malfunctioning intake door position is detected at REC position	
B2654	D/F2 DOOR FAIL	When the malfunctioning door position is detected at D/F position	<ul style="list-style-type: none"> <li>Mode door motor</li> <li>A/C auto amp.</li> <li>Harness and connector (CAN communication line is open or shorted)</li> <li>(Mode door motor is open or shorted)</li> </ul>
B2655	B/L2 DOOR FAIL	When the malfunctioning door position is detected at B/L2 position	
B2661	UPPER VENT DOOR OPEN POSI FAIL	When the malfunctioning upper ventilator door position is detected at open position.	<ul style="list-style-type: none"> <li>Upper ventilator door motor</li> <li>A/C auto amp.</li> <li>Harness and connector (CAN communication line is open or shorted)</li> <li>(Upper ventilator door motor is open or shorted)</li> </ul>
B2662	UPPER VENT DOOR MID POSI FAIL	When the malfunctioning upper ventilator door position is detected at middle position.	
B2663	UPPER VENT DOOR SHUT POSI FAIL	When the malfunctioning upper ventilator door position is detected at shut position.	

\*: Perform self-diagnosis under sunshine. When performing indoors, aim a light (more than 60 W) at sunload sensor, otherwise self-diagnosis indicates even though the sunload sensor is functioning normally.

## DATA MONITOR

Display item list

Monitor item [Unit]	Description
COMP REQ SIG [On/Off]	Displays A/C switch ON/OFF status transmitted to other units via CAN communication
FAN REQ SIG [On/Off]	Displays blower switch ON/OFF status transmitted to other units via CAN communication
AMB TEMP SEN [°C]	Ambient sensor value converted from ambient sensor signal received from ambient sensor
IN-VEH TEMP [°C]	In-vehicle sensor value converted from in-vehicle sensor signal received from in-vehicle sensor
INT TEMP SEN [°C]	Intake sensor value converted from intake sensor signal received from intake sensor
SUNLOAD SEN [w/m <sup>2</sup> ]	Sunload sensor value converted from sunload sensor signal received from sunload sensor



# DIAGNOSIS SYSTEM (HVAC)

< SYSTEM DESCRIPTION >

[WITHOUT 7 INCH DISPLAY]

Monitor item [Unit]	Description
AMB SEN CAL [°C]	Ambient sensor value calculated by A/C auto amp.
IN-VEH CAL [°C]	In-vehicle sensor value calculated by A/C auto amp.
INT TEMP CAL [°C]	Intake sensor value calculated by A/C auto amp.
SUNL SEN CAL [w/m <sup>2</sup> ]	Sunload sensor value calculated by A/C auto amp.
FAN DUTY	Duty ratio of blower motor judged by A/C auto amp.
XM	Target discharge air temperature judged by A/C auto amp. according to the temperature setting and the value from each sensor
ENG COOL TEMP [°C]	Water temperature signal value received from ECM via CAN communication
VEHICLE SPEED [Mph (km/h)]	Vehicle speed signal value received from meter via CAN communication

## ACTIVE TEST

Test item	Description
ALL SEG	<b>NOTE:</b> <ul style="list-style-type: none"> <li>Item can be displayed but cannot be tested.</li> <li>When choosing to turn "ALL SEG" on, error message is displayed but it is not malfunction.</li> </ul>
HVAC TEST	The operation check of A/C system can be performed by selecting the mode. Refer to the following table for the conditions of each mode.

## HVAC TEST

	Test item						
	MODE 1	MODE 2	MODE 3	MODE 4	MODE 5	MODE 6	MODE 7
Mode door position	VENT1	VENT2	B/L1	B/L2	FOOT	D/F	DEF
Intake door position	REC	REC	20%FRE	20%FRE	FRE	FRE	FRE
Air mix door position (driver & passenger side)	FULL COLD	FULL HOT	FULL COLD	FULL HOT	FULL HOT	FULL HOT	FULL HOT
Blower motor duty ratio	35%	35%	61%	61%	81%	81%	35%
Compressor (Magnet clutch)	ON	ON	ON	ON	OFF	OFF	ON
Upper ventilator door	OPEN	SHUT	OPEN	SHUT	SHUT	SHUT	SHUT

### NOTE:

Perform the inspection of each output device after starting the engine because the compressor is operated.

## WORK SUPPORT

Work item	Description	Reference
TEMP SET CORRECT (Setting of difference between temperature setting and control temperature)	If the temperature felt by the customer is different than the air flow temperature controlled by the temperature setting, the auto amplifier control temperature can be adjusted to compensate for the temperature setting.	<a href="#">HAC-9. "Temperature Setting Trimmer"</a>
BLOW SET (Blow setting to DEF in FOOT mode)	In the FOOT mode, the air blowing to the DEF can change ON/OFF.	<a href="#">HAC-9. "Foot Position Setting Trimmer"</a>

# DIAGNOSIS SYSTEM (HVAC)

< SYSTEM DESCRIPTION >

[WITHOUT 7 INCH DISPLAY]

Work item	Description	Reference
FRE MEMORY SET (FRE memory function setting)	<ul style="list-style-type: none"><li>• If the ignition switch is turned to the OFF position while the FRE switch is set to ON (fresh air intake), "Perform the memory" or "Do not perform the memory" of the FRE switch ON (fresh air intake) condition can be selected.</li><li>• If "Perform the memory" was set, the FRE switch will be ON (fresh air intake) when turning the ignition switch to the ON position again.</li><li>• If "Do not perform the memory" was set, the air inlets will be controlled automatically when turning the ignition switch to the ON position again.</li></ul>	<a href="#">HAC-10. "Inlet Port Memory Function (FRE)"</a>
REC MEMORY SET (REC memory function setting)	<ul style="list-style-type: none"><li>• If the ignition switch is turned to the OFF position while the REC switch is set to ON (recirculation), "Perform the memory" or "Do not perform the memory" of the REC switch ON (recirculation) condition can be selected.</li><li>• If "Perform the memory" was set, the REC switch will be ON (recirculation) when turning the ignition switch to the ON position again.</li><li>• If "Do not perform the memory" was set, the air inlets will be controlled automatically when turning the ignition switch to the ON position again.</li></ul>	<a href="#">HAC-10. "Inlet Port Memory Function (REC)"</a>

**NOTE:**

When the battery cable is disconnected from the negative terminal or when the battery voltage becomes 10 V or less, the setting of WORK SUPPORT may be cancelled.

## DTC/CIRCUIT DIAGNOSIS

### U1000 CAN COMM CIRCUIT

#### Description

INFOID:000000005514596

CAN (Controller Area Network) is a serial communication line for real time application. It is an on-vehicle multiplex communication line with high data communication speed and excellent error detection ability. Many electronic control units are equipped onto a vehicle, and each control unit shares information and links with other control units during operation (not independent). In CAN communication, control units are connected with two communication lines (CAN-H line, CAN-L line) allowing a high rate of information transmission with less wiring. Each control unit transmits/receives data but selectively reads required data only.

CAN Communication Signal Chart. Refer to [LAN-16, "How to Use CAN Communication Signal Chart"](#).

#### DTC Logic

INFOID:000000005514597

#### DTC DETECTION LOGIC

DTC	Items (CONSULT-III screen terms)	Diagnostic item is detected when...	Possible cause
U1000	CAN COMM CIRCUIT	When A/C auto amp. is not transmitting or receiving CAN communication signal for 2 or more seconds.	CAN communication system

#### Diagnosis Procedure

INFOID:000000005514598

#### 1. CHECK WITH SELF-DIAGNOSIS FUNCTION OF CONSULT-III

1. Turn ignition switch ON and wait for 2 or more seconds.
2. Using CONSULT-III, perform "SFLF-DIAGNOSIS RESULTS" of HVAC.

Is "CAN COMM CIRCUIT" displayed?

- YES >> Perform trouble diagnosis for the CAN communication system. Refer to [LAN-17, "Trouble Diagnosis Flow Chart"](#).
- NO >> Perform the intermittent malfunction diagnosis. Refer to [GI-39, "Intermittent Incident"](#).

# U1010 CONTROL UNIT (CAN)

< DTC/CIRCUIT DIAGNOSIS >

[WITHOUT 7 INCH DISPLAY]

## U1010 CONTROL UNIT (CAN)

### Description

INFOID:000000005514599

Initial diagnosis of A/C auto amp.

### DTC Logic

INFOID:000000005514600

### DTC DETECTION LOGIC

DTC	Items (CONSULT-III screen terms)	Diagnostic item is detected when...	Possible cause
U1010	CONTROL UNIT (CAN)	When detecting error during the initial diagnosis of CAN controller of A/C auto amp.	A/C auto amp.

### Diagnosis Procedure

INFOID:000000005514601

#### 1. CHECK WITH SELF-DIAGNOSIS FUNCTION OF CONSULT-III

Using CONSULT-III, perform "SELF-DIAGNOSIS RESULTS" of HVAC.

Is DTC No. "U1010" displayed?

- YES >> Replace A/C auto amp.
- NO >> INSPECTION END

# B257B, B257C AMBIENT SENSOR

< DTC/CIRCUIT DIAGNOSIS >

[WITHOUT 7 INCH DISPLAY]

## B257B, B257C AMBIENT SENSOR

### Description

INFOID:000000005514602

### COMPONENT DESCRIPTION

#### Ambient Sensor

- The ambient sensor (1) is installed to the front bumper (left back).
- It detects ambient temperature and converts it into a resistance value which is then input into the A/C auto amp.

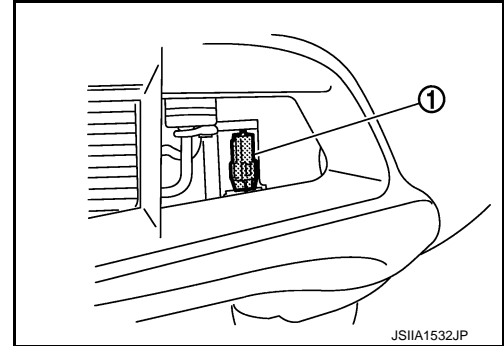

#### Ambient Sensor Circuit

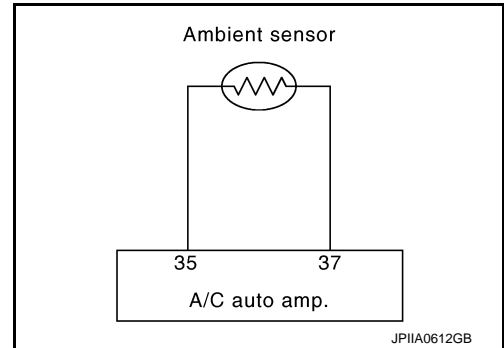

### AMBIENT TEMPERATURE INPUT PROCESS

The A/C auto amp. equips a processing circuit for the ambient sensor input. However, when the temperature detected by the ambient sensor increases quickly, the processing circuit retards the A/C auto amp. function. It only allows the A/C auto amp. to recognize an ambient temperature increase of 0.33°C (0.6°F) per 100 seconds.

As an example, consider stopping for a few minutes after high speed driving. Although the actual ambient temperature has not changed, the temperature detected by the ambient sensor increases. This is because the heat from the engine compartment can radiate to the front bumper area, the location of the ambient sensor.

### DTC Logic

INFOID:000000005514603

#### DTC DETECTION LOGIC

##### NOTE:

- If DTC is displayed along with DTC U1000 or U1010, first diagnose the DTC U1000 or U1010. Refer to [HAC-43, "DTC Logic"](#) or [HAC-44, "DTC Logic"](#).
- If there is an open circuit in the ambient sensor, A/C auto amp. registers extreme cold [-44°C (-47°F)] and adjusts the temperature control warmer.

DTC	Items (CONSULT-III screen terms)	Diagnostic item is detected when...	Possible cause
B257B	AMB TEMP SEN SHORT	Detected temperature at ambient sensor -44°C (-47°F) or less	<ul style="list-style-type: none"> <li>• Ambient sensor</li> <li>• A/C auto amp.</li> </ul>
B257C	AMB TEMP SEN OPEN	Detected temperature at ambient sensor 100°C (212°F) or more	<ul style="list-style-type: none"> <li>• Harness and connector (Ambient sensor circuit is open, or there is a short in the circuit)</li> </ul>

### DTC CONFIRMATION PROCEDURE

1. CHECK WITH SELF-DIAGNOSIS FUNCTION OF CONSULT-III

# B257B, B257C AMBIENT SENSOR

< DTC/CIRCUIT DIAGNOSIS >

[WITHOUT 7 INCH DISPLAY]

1. Using CONSULT-III, perform "SELF-DIAGNOSIS RESULTS" of HVAC.
2. Check if any DTC No. is displayed in the self-diagnosis results.

## NOTE:

- If DTC is displayed along with DTC U1000 or U1010, first diagnose the DTC U1000 or U1010. Refer to [HAC-43, "DTC Logic"](#) or [HAC-44, "DTC Logic"](#).
- If there is an open circuit in the ambient sensor, A/C auto amp. registers extreme cold [ $-44^{\circ}\text{C}$  ( $-47^{\circ}\text{F}$ )] and adjusts the temperature control warmer.

Is DTC No. "B257B" or "B257C" displayed?

- YES >> Perform trouble diagnosis for the ambient sensor. Refer to [HAC-46, "Diagnosis Procedure"](#).  
NO >> INSPECTION END

## Diagnosis Procedure

INFOID:000000005514604

### 1. CHECK VOLTAGE BETWEEN AMBIENT SENSOR AND GROUND

1. Disconnect ambient sensor connector.
2. Turn ignition switch ON.
3. Check voltage between ambient sensor harness connector and ground.

(+)		(-)	Voltage
Ambient sensor		—	
Connector	Terminal		
E337	1	Ground	Approx. 5 V

Is the inspection result normal?

- YES >> GO TO 2.  
NO >> GO TO 4.

### 2. CHECK CIRCUIT CONTINUITY BETWEEN AMBIENT SENSOR AND A/C AUTO AMP.

1. Turn ignition switch OFF.
2. Disconnect A/C auto amp. connector.
3. Check continuity between ambient sensor harness connector and A/C auto amp. harness connector.

Ambient sensor		A/C auto amp.		Continuity
Connector	Terminal	Connector	Terminal	
E337	2	M50	37	Existed

Is the inspection result normal?

- YES >> GO TO 3.  
NO >> Repair harness or connector.

### 3. CHECK AMBIENT SENSOR

Check ambient sensor. Refer to [HAC-47, "Component Inspection"](#).

Is the inspection result normal?

- YES >> Replace A/C auto amp.  
NO >> Replace ambient sensor.

### 4. CHECK CIRCUIT CONTINUITY BETWEEN AMBIENT SENSOR AND A/C AUTO AMP.

1. Turn ignition switch OFF.
2. Disconnect A/C auto amp. connector.
3. Check continuity between ambient sensor harness connector and A/C auto amp. harness connector.

Ambient sensor		A/C auto amp.		Continuity
Connector	Terminal	Connector	Terminal	
E337	1	M50	35	Existed

4. Check continuity between ambient sensor harness connector and ground.

# B257B, B257C AMBIENT SENSOR

< DTC/CIRCUIT DIAGNOSIS >

[WITHOUT 7 INCH DISPLAY]

Ambient sensor		—	Continuity
Connector	Terminal		
E337	1	Ground	Not existed

Is the inspection result normal?

YES >> Replace A/C auto amp.

NO >> Repair harness or connector.

## Component Inspection

INFOID:000000005514605

### 1. CHECK AMBIENT SENSOR

1. Turn ignition switch OFF.
2. Disconnect ambient sensor connector. Refer to [VTL-26. "Exploded View"](#).
3. Check resistance between ambient sensor terminals.

Terminal		Condition	Resistance kΩ
		Temperature °C (°F)	
1	2	-15 (5)	12.73
		-10 (14)	9.92
		-5 (23)	7.80
		0 (32)	6.19
		5 (41)	4.95
		10 (50)	3.99
		15 (59)	3.24
		20 (68)	2.65
		25 (77)	2.19
		30 (86)	1.81
		35 (95)	1.51
		40 (104)	1.27
45 (113)	1.07		

Is the inspection result normal?

YES >> INSPECTION END

NO >> Replace ambient sensor.

# B2578, B2579 IN-VEHICLE SENSOR

< DTC/CIRCUIT DIAGNOSIS >

[WITHOUT 7 INCH DISPLAY]

## B2578, B2579 IN-VEHICLE SENSOR

### Description

INFOID:000000005514606

#### In-vehicle Sensor

- The in-vehicle sensor (1) is located on instrument driver lower panel (2).
- It converts variations in compartment air temperature drawn from the aspirator into a resistance value. It is then input into the A/C auto amp.

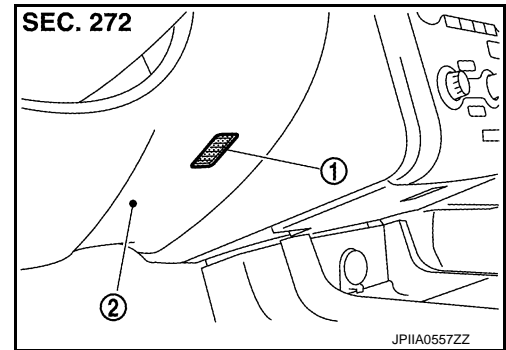

#### In-vehicle Sensor Circuit

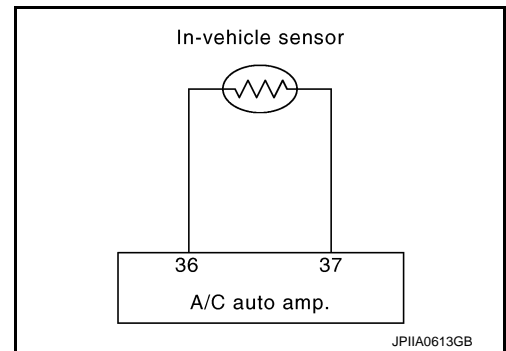

#### Aspirator

The aspirator (1) is located on driver side of heater & cooling unit assembly. It produces vacuum pressure due to air discharged from the heater & cooling unit assembly, continuously taking compartment air in the aspirator.

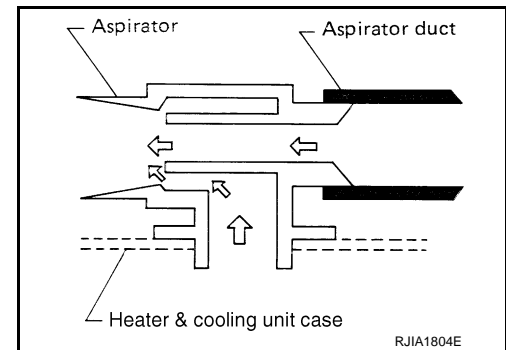
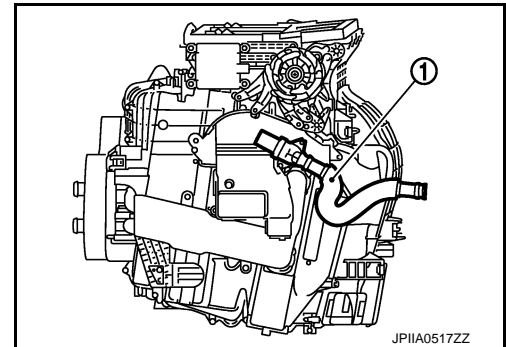

### DTC Logic

INFOID:000000005514607

### DTC DETECTION LOGIC



## B2578, B2579 IN-VEHICLE SENSOR

< DTC/CIRCUIT DIAGNOSIS >

[WITHOUT 7 INCH DISPLAY]

**NOTE:**

If DTC is displayed along with DTC U1000 or U1010, first diagnose the DTC U1000 or U1010. Refer to [HAC-43. "DTC Logic"](#) or [HAC-44. "DTC Logic"](#).

DTC	Items (CONSULT-III screen terms)	Diagnostic item is detected when...	Possible cause
B2578	IN CAR SEN SHORT	Detected temperature at in-vehicle sensor -44°C (-47°F) or less	<ul style="list-style-type: none"> <li>• In-vehicle sensor</li> <li>• A/C auto amp.</li> <li>• Harness and connector (In-vehicle sensor circuit is open, or there is a short in the circuit)</li> </ul>
B2579	IN CAR SEN OPEN	Detected temperature at in-vehicle sensor 100°C (212°F) or more	

### DTC CONFIRMATION PROCEDURE

#### 1. CHECK WITH SELF-DIAGNOSIS FUNCTION OF CONSULT-III

1. Using CONSULT-III, perform "SELF-DIAGNOSIS RESULTS" of HVAC.
2. Check if any DTC No. is displayed in the self-diagnosis results.

**NOTE:**

If DTC is displayed along with DTC U1000 or U1010, first diagnose the DTC U1000 or U1010. Refer to [HAC-43. "DTC Logic"](#) or [HAC-44. "DTC Logic"](#).

Is DTC No. "B2578" or "B2579" displayed?

- YES >> Perform trouble diagnosis for the in-vehicle sensor. Refer to [HAC-49. "Diagnosis Procedure"](#).  
 NO >> INSPECTION END

### Diagnosis Procedure

INFOID:000000005514608

#### 1. CHECK VOLTAGE BETWEEN IN-VEHICLE SENSOR AND GROUND

1. Disconnect in-vehicle sensor connector.
2. Turn ignition switch ON.
3. Check voltage between in-vehicle sensor harness connector and ground.

(+)		(-)	Voltage
Connector	Terminal		
M41	1	Ground	Approx. 5 V

Is the inspection result normal?

- YES >> GO TO 2.  
 NO >> GO TO 4.

#### 2. CHECK CIRCUIT CONTINUITY BETWEEN IN-VEHICLE SENSOR AND A/C AUTO AMP.

1. Turn ignition switch OFF.
2. Disconnect A/C auto amp. connector.
3. Check continuity between in-vehicle sensor harness connector and A/C auto amp. harness connector.

In-vehicle sensor		A/C auto amp.		Continuity
Connector	Terminal	Connector	Terminal	
M41	2	M50	37	Existed

Is the inspection result normal?

- YES >> GO TO 3.  
 NO >> Repair harness or connector.

#### 3. CHECK IN-VEHICLE SENSOR

Check in-vehicle sensor. Refer to [HAC-50. "Component Inspection"](#).

Is the inspection result normal?

- YES >> Replace A/C auto amp.

## B2578, B2579 IN-VEHICLE SENSOR

< DTC/CIRCUIT DIAGNOSIS >

[WITHOUT 7 INCH DISPLAY]

NO >> Replace in-vehicle sensor.

### 4. CHECK CIRCUIT CONTINUITY BETWEEN IN-VEHICLE SENSOR AND A/C AUTO AMP.

1. Turn ignition switch OFF.
2. Disconnect A/C auto amp. connector.
3. Check continuity between in-vehicle sensor harness connector and A/C auto amp. harness connector.

In-vehicle sensor		A/C auto amp.		Continuity
Connector	Terminal	Connector	Terminal	
M41	1	M50	36	Existed

4. Check continuity between in-vehicle sensor harness connector and ground.

In-vehicle sensor		—	Continuity
Connector	Terminal		
M41	1	Ground	Not existed

Is the inspection result normal?

YES >> Replace A/C auto amp.

NO >> Repair harness or connector.

## Component Inspection

INFOID:000000005514609

### 1. CHECK IN-VEHICLE SENSOR

1. Turn ignition switch OFF.
2. Disconnect in-vehicle sensor connector. Refer to [VTL-27. "Exploded View"](#).
3. Check resistance between in-vehicle sensor terminals.

Terminal	Condition		Resistance kΩ
	Temperature °C (°F)		
1	2	-15 (5)	12.73
		-10 (14)	9.92
		-5 (23)	7.80
		0 (32)	6.19
		5 (41)	4.95
		10 (50)	3.99
		15 (59)	3.24
		20 (68)	2.65
		25 (77)	2.19
		30 (86)	1.81
		35 (95)	1.51
		40 (104)	1.27
		45 (113)	1.07

Is the inspection result normal?

YES >> INSPECTION END

NO >> Replace in-vehicle sensor.

# B2581, B2582 INTAKE SENSOR

< DTC/CIRCUIT DIAGNOSIS >

[WITHOUT 7 INCH DISPLAY]

## B2581, B2582 INTAKE SENSOR

### Description

INFOID:000000005514610

#### Intake Sensor

- The intake sensor (1) is located on the evaporator (2).
- It converts air temperature after it passes through the evaporator into a resistance value which is then input to the A/C auto amp.

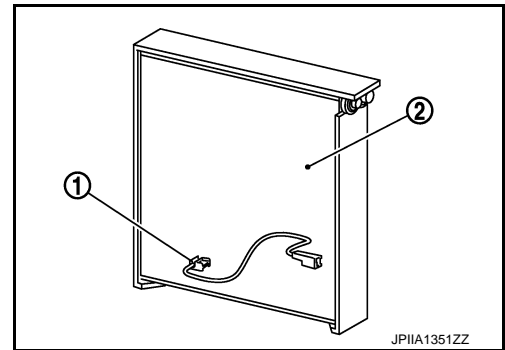

#### Intake Sensor Circuit

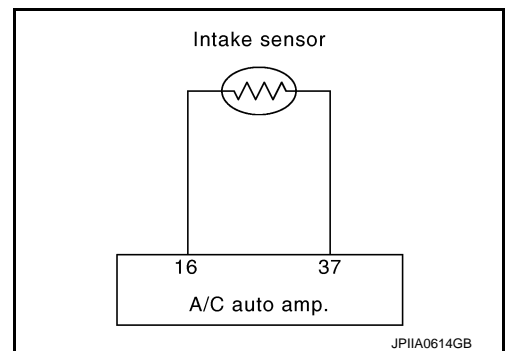

### DTC Logic

INFOID:000000005514611

#### DTC DETECTION LOGIC

##### NOTE:

If DTC is displayed along with DTC U1000 or U1010, first diagnose the DTC U1000 or U1010. Refer to [HAC-43, "DTC Logic"](#) or [HAC-44, "DTC Logic"](#).

DTC	Items (CONSULT-III screen terms)	Diagnostic item is detected when...	Possible cause
B2581	EVAP TEMP SEN SHORT	Detected temperature at intake sensor -33°C (-27°F) or less	<ul style="list-style-type: none"> <li>• Intake sensor</li> <li>• A/C auto amp.</li> <li>• Harness and connector (Intake sensor circuit is open, or there is a short in the circuit)</li> </ul>
B2582	EVAP TEMP SEN OPEN	Detected temperature at intake sensor 69°C (156°F) or more	

#### DTC CONFIRMATION PROCEDURE

##### 1. CHECK WITH SELF-DIAGNOSIS FUNCTION OF CONSULT-III

1. Using CONSULT-III, perform "SELF-DIAGNOSIS RESULTS" of HVAC.
2. Check if any DTC No. is displayed in the self-diagnosis results.

##### NOTE:

If DTC is displayed along with DTC U1000 or U1010, first diagnose the DTC U1000 or U1010. Refer to [HAC-43, "DTC Logic"](#) or [HAC-44, "DTC Logic"](#).

Is DTC No. "B2581" or "B2582" displayed?

- YES >> Perform trouble diagnosis for the intake sensor. Refer to [HAC-51, "Diagnosis Procedure"](#).
- NO >> INSPECTION END

### Diagnosis Procedure

INFOID:000000005514612

##### 1. CHECK VOLTAGE BETWEEN INTAKE SENSOR AND GROUND

# B2581, B2582 INTAKE SENSOR

< DTC/CIRCUIT DIAGNOSIS >

[WITHOUT 7 INCH DISPLAY]

1. Disconnect intake sensor connector.
2. Turn ignition switch ON.
3. Check voltage between intake sensor harness connector and ground.

(+)		(-)	Voltage
Intake sensor		—	
Connector	Terminal		
M42	1	Ground	Approx. 5 V

Is the inspection result normal?

- YES >> GO TO 2.  
NO >> GO TO 4.

## 2.CHECK CIRCUIT CONTINUITY BETWEEN INTAKE SENSOR AND A/C AUTO AMP.

1. Turn ignition switch OFF.
2. Disconnect A/C auto amp. connector.
3. Check continuity between intake sensor harness connector and A/C auto amp. harness connector.

Intake sensor		A/C auto amp.		Continuity
Connector	Terminal	Connector	Terminal	
M42	2	M50	37	Existed

Is the inspection result normal?

- YES >> GO TO 3.  
NO >> Repair harness or connector.

## 3.CHECK INTAKE SENSOR

Check intake sensor. Refer to [HAC-52, "Component Inspection"](#).

Is the inspection result normal?

- YES >> Replace A/C auto amp.  
NO >> Replace intake sensor.

## 4.CHECK CIRCUIT CONTINUITY BETWEEN INTAKE SENSOR AND A/C AUTO AMP.

1. Turn ignition switch OFF.
2. Disconnect A/C auto amp. connector.
3. Check continuity between intake sensor harness connector and A/C auto amp. harness connector.

Intake sensor		A/C auto amp.		Continuity
Connector	Terminal	Connector	Terminal	
M42	1	M50	16	Existed

4. Check continuity between intake sensor harness connector and ground.

Intake sensor		(-)	Continuity
Connector	Terminal		
M42	1	Ground	Not existed

Is the inspection result normal?

- YES >> Replace A/C auto amp.  
NO >> Repair harness or connector.

## Component Inspection

INFOID:000000005514613

## 1.CHECK INTAKE SENSOR

1. Turn ignition switch OFF.
2. Disconnect intake sensor connector.
3. Check resistance between intake sensor terminals.

# B2581, B2582 INTAKE SENSOR

< DTC/CIRCUIT DIAGNOSIS >

[WITHOUT 7 INCH DISPLAY]

Terminal		Condition	Resistance kΩ
		Temperature °C (°F)	
1	2	-15 (5)	18.63
		-10 (14)	14.15
		-5 (23)	10.86
		0 (32)	8.41
		5 (41)	6.58
		10 (50)	5.19
		15 (59)	4.12
		20 (68)	3.30
		25 (77)	2.67
		30 (86)	2.17
		35 (95)	1.78
		40 (104)	1.46
		45 (113)	1.21

Is the inspection result normal?

YES >> INSPECTION END

NO >> Replace intake sensor.

A

B

C

D

E

F

G

H

HAC

J

K

L

M

N

O

P

# B2630, B2631 SUNLOAD SENSOR

< DTC/CIRCUIT DIAGNOSIS >

[WITHOUT 7 INCH DISPLAY]

## B2630, B2631 SUNLOAD SENSOR

### Description

INFOID:000000005514614

### COMPONENT DESCRIPTION

#### Sunload Sensor

- The sunload sensor (1) is located on the driver's side instrument panel & pad.
- It detects sunload entering through windshield by means of a photo diode. The sensor converts the sunload into a current value which is then input into the A/C auto amp.

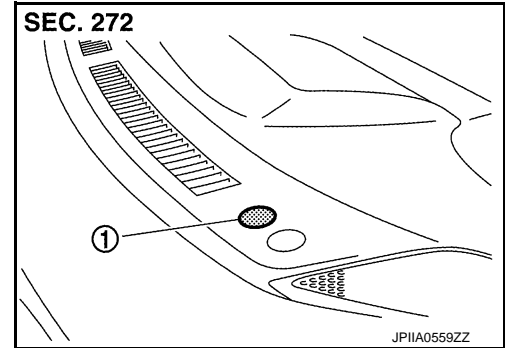

#### Sunload Sensor Circuit

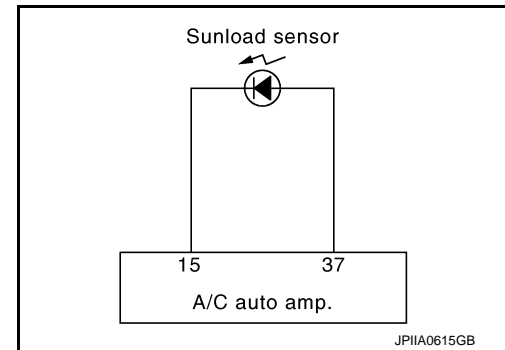

### SUNLOAD INPUT PROCESS

The A/C auto amp. also equips a processing circuit which averages the variations in detected sunload over a period of time. This prevents drastic swings in the air temperature control system operation due to small or quick variations in detected sunload.

For example, consider driving along a road bordered by an occasional group of large trees. The sunload detected by the sunload sensor varies whenever the trees obstruct the sunlight. The processing circuit averages the detected sunload over a period of time, so that the (insignificant) effect of the trees momentarily obstructing the sunlight does not cause any change in the air temperature control system operation. On the other hand, shortly after entering a long tunnel, the system recognizes the change in sunload, and the system reacts accordingly.

### DTC Logic

INFOID:000000005514615

### DTC DETECTION LOGIC

#### NOTE:

- If DTC is displayed along with DTC U1000 or U1010, first diagnose the DTC U1000 or U1010. Refer to [HAC-43. "DTC Logic"](#) or [HAC-44. "DTC Logic"](#).
- Sunload sensor may register a malfunction when indoors, at dusk, or at other times when light is insufficient. When performing the diagnosis indoors, light the sunload sensor with a lamp (60W or more).

DTC	Items (CONSULT-III screen terms)	Diagnostic item is detected when...	Possible cause
B2630	SUNLOAD SEN SHORT	Detected calorie at sunload sensor 64.7 w/m <sup>2</sup> (56 kcal/m <sup>2</sup> ·h) or less	<ul style="list-style-type: none"> <li>• Sunload sensor</li> <li>• A/C auto amp.</li> <li>• Harness and connector</li> </ul>
B2631	SUNLOAD SEN OPEN	Detected calorie at sunload sensor 2832 w/m <sup>2</sup> (2436 kcal/m <sup>2</sup> ·h) or more	(Sunload sensor circuit is open, or there is a short in the circuit)

# B2630, B2631 SUNLOAD SENSOR

< DTC/CIRCUIT DIAGNOSIS >

[WITHOUT 7 INCH DISPLAY]

## DTC CONFIRMATION PROCEDURE

### 1. CHECK WITH SELF-DIAGNOSIS FUNCTION OF CONSULT-III

- Using CONSULT-III, perform "SELF-DIAGNOSIS RESULTS" of HVAC.
- Check if any DTC No. is displayed in the self-diagnosis results.

#### NOTE:

- If DTC is displayed along with DTC U1000 or U1010, first diagnose the DTC U1000 or U1010. Refer to [HAC-43, "DTC Logic"](#) or [HAC-44, "DTC Logic"](#).
- Sunload sensor may register a malfunction when indoors, at dusk, or at other times when light is insufficient. When performing the diagnosis indoors, light the sunload sensor with a lamp (60W or more).

Is DTC No. "B2630" or "B2631" displayed?

- YES >> Perform trouble diagnosis for the sunload sensor. Refer to [HAC-55, "Diagnosis Procedure"](#).  
NO >> INSPECTION END

## Diagnosis Procedure

INFOID:000000005514616

### 1. CHECK VOLTAGE BETWEEN SUNLOAD SENSOR AND GROUND

- Disconnect sunload sensor connector.
- Turn ignition switch ON.
- Check voltage between sunload sensor harness connector and ground.

(+)		(-)	Voltage
Sunload sensor		—	
Connector	Terminal		
M74	1	Ground	Approx. 5 V

Is the inspection result normal?

- YES >> GO TO 2.  
NO >> GO TO 4.

### 2. CHECK CIRCUIT CONTINUITY BETWEEN SUNLOAD SENSOR AND A/C AUTO AMP.

- Turn ignition switch OFF.
- Disconnect A/C auto amp. connector.
- Check continuity between sunload sensor harness connector and A/C auto amp. harness connector.

Sunload sensor		A/C auto amp.		Continuity
Connector	Terminal	Connector	Terminal	
M74	2	M50	37	Existed

Is the inspection result normal?

- YES >> GO TO 3.  
NO >> Repair harness or connector.

### 3. CHECK SUNLOAD SENSOR

- Reconnect sunload sensor connector and A/C auto amp. connector.
- Check sunload sensor. Refer to [HAC-56, "Component Inspection"](#).

Is the inspection result normal?

- YES >> Replace A/C auto amp.  
NO >> Replace sunload sensor.

### 4. CHECK CIRCUIT CONTINUITY BETWEEN SUNLOAD SENSOR AND A/C AUTO AMP.

- Turn ignition switch OFF.
- Disconnect A/C auto amp. connector.
- Check continuity between sunload sensor harness connector and A/C auto amp. harness connector.

# B2630, B2631 SUNLOAD SENSOR

< DTC/CIRCUIT DIAGNOSIS >

[WITHOUT 7 INCH DISPLAY]

Sunload sensor		A/C auto amp.		Continuity
Connector	Terminal	Connector	Terminal	
M74	1	M50	15	Existed

4. Check continuity between sunload sensor harness connector and ground.

Sunload sensor		—	Continuity
Connector	Terminal		
M74	1	Ground	Not existed

Is the inspection result normal?

YES >> Replace A/C auto amp.

NO >> Repair harness or connector.

## Component Inspection

INFOID:000000005514617

### 1. CHECK SUNLOAD SENSOR

1. Turn ignition switch ON.
2. Check voltage between A/C auto amp. harness connector and ground.

(+) A/C auto amp.		(-)
Connector	Terminal	—
M50	15	Ground

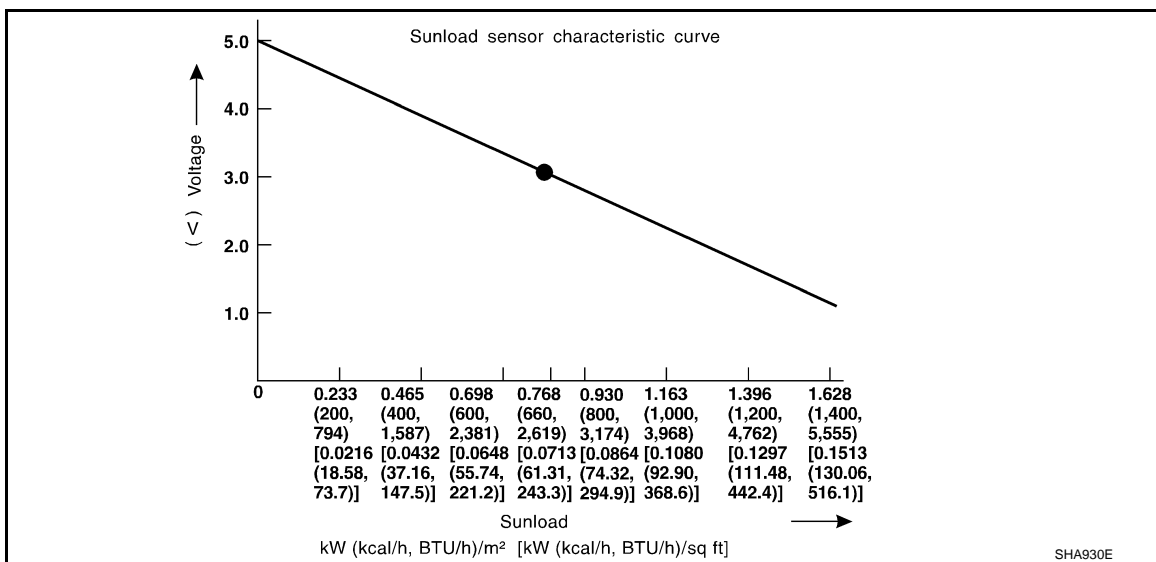

**NOTE:**

Select a place where sunshine directly on it when checking sunload sensor.

Is the inspection result normal?

YES >> INSPECTION END

NO >> Replace sunload sensor.



# B2632, B2633 AIR MIX DOOR MOTOR (DRIVER SIDE)

< DTC/CIRCUIT DIAGNOSIS >

[WITHOUT 7 INCH DISPLAY]

## B2632, B2633 AIR MIX DOOR MOTOR (DRIVER SIDE)

### Description

INFOID:000000005514618

### COMPONENT DESCRIPTION

Air Mix Door Motor (Driver Side)

- The air mix door motor (driver side) (1) are attached to the heater & cooling unit assembly.

←: Vehicle front

- It rotates so that the air mix door is opened or closed to a position set by the A/C auto amp.
- Motor rotation is then conveyed through a shaft and the air mix door position feedback is then sent to the A/C auto amp. by PBR built-in air mix door motor.

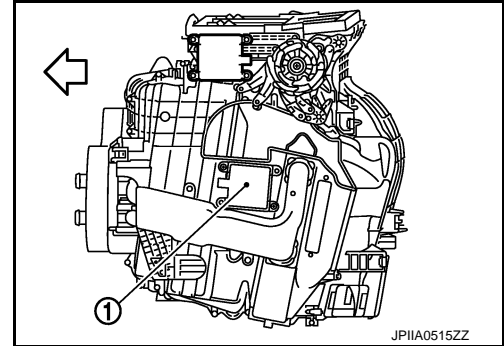

### DTC Logic

INFOID:000000005514619

### DTC DETECTION LOGIC

#### NOTE:

If DTC is displayed along with DTC U1000 or U1010, first diagnose the DTC U1000 or U1010. Refer to [HAC-43. "DTC Logic"](#) or [HAC-44. "DTC Logic"](#).

DTC	Items (CONSULT-III screen terms)	Diagnostic item is detected when...	Possible cause
B2632	DR AIRMIX ACTR SHORT	Air mix door PBR (driver side) position 95% or less	<ul style="list-style-type: none"><li>• Air mix door motor (PBR internal circuit is open or shorted)</li><li>• A/C auto amp.</li><li>• Harness and connector (LAN communication line is open or shorted)</li></ul>
B2633	DR AIRMIX ACTR OPEN	Air mix door PBR (driver side) position 5% or more	

HAC

### DTC CONFIRMATION PROCEDURE

#### 1. CHECK WITH SELF-DIAGNOSIS FUNCTION OF CONSULT-III

1. Using CONSULT-III, perform "SELF-DIAGNOSIS RESULTS" of HVAC.
2. Check if any DTC No. is displayed in the self-diagnosis results.

#### NOTE:

If DTC is displayed along with DTC U1000 or U1010, first diagnose the DTC U1000 or U1010. Refer to [HAC-43. "DTC Logic"](#) or [HAC-44. "DTC Logic"](#).

Is DTC No. "B2632" or "B2633" displayed?

YES >> Perform trouble diagnosis for the air mix door motor (driver side). Refer to [HAC-58. "Diagnosis Procedure"](#).

NO >> GO TO 2.

#### 2. FUNCTION INSPECTION

1. Press temperature control "UP" switch (driver side) until 32°C (90°F) is displayed.
2. Check for warm air at discharge air outlets.
3. Operate the compressor.
4. Press temperature control "DOWN" switch (driver side) until 18°C (60°F) is displayed.
5. Check for cool air at air discharge outlets.

Does it operate normally?

YES >> INSPECTION END

NO >> Check air mix door motor (driver side) installation, and repair or replace the malfunctioning parts.

# B2632, B2633 AIR MIX DOOR MOTOR (DRIVER SIDE)

< DTC/CIRCUIT DIAGNOSIS >

[WITHOUT 7 INCH DISPLAY]

INFOID:000000005514620

## Diagnosis Procedure

### 1. CHECK POWER SUPPLY FOR AIR MIX DOOR MOTOR (DRIVER SIDE)

Check voltage between air mix door motor (driver side) harness connector and ground.

(+)		(-)	Voltage
Air mix door motor (driver side)		—	
Connector	Terminal		
M306	1	Ground	Battery voltage

Is the inspection result normal?

YES >> GO TO 2.

NO >> Repair the harnesses or connectors.

### 2. CHECK SIGNAL FOR AIR MIX DOOR MOTOR (DRIVER SIDE)

Check the output waveform (LAN signal) between air mix door motor (driver side) harness connector and ground using an oscilloscope.

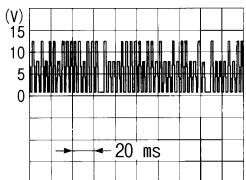
(+)		(-)	Voltage
Air mix door motor (driver side)		—	
Connector	Terminal		
M306	3	Ground	 SJIA1453J

Is the inspection result normal?

YES >> GO TO 3.

NO >> Repair the harnesses or connectors.

### 3. CHECK AIR MIX DOOR MOTOR (DRIVER SIDE) GROUND CIRCUIT

1. Turn ignition switch OFF.
2. Disconnect air mix door motor (driver side) connector.
3. Check continuity between air mix door motor (driver side) harness connector and ground.

Air mix door motor (driver side)		(-)	Continuity
		—	
Connector	Terminal		
M306	2	Ground	Existed

Is the inspection result normal?

YES >> Replace air mix door motor (driver side).

NO >> Repair harness or connector.

# B2634, B2635 AIR MIX DOOR MOTOR (PASSENGER SIDE)

< DTC/CIRCUIT DIAGNOSIS >

[WITHOUT 7 INCH DISPLAY]

## B2634, B2635 AIR MIX DOOR MOTOR (PASSENGER SIDE)

### Description

INFOID:000000005514621

### COMPONENT DESCRIPTION

Air Mix Door Motor (Passenger Side)

- The air mix door motor (passenger side) (1) are attached to the heater & cooling unit assembly.

←: Vehicle front

- It rotates so that the air mix door is opened or closed to a position set by the A/C auto amp.
- Motor rotation is then conveyed through a shaft and the air mix door position feedback is then sent to the A/C auto amp. by PBR built-in air mix door motor.

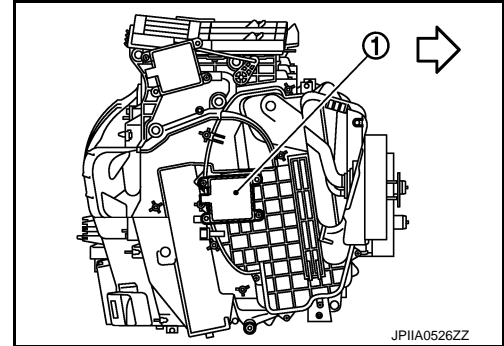

### DTC Logic

INFOID:000000005514622

### DTC DETECTION LOGIC

#### NOTE:

If DTC is displayed along with DTC U1000 or U1010, first diagnose the DTC U1000 or U1010. Refer to [HAC-43. "DTC Logic"](#) or [HAC-44. "DTC Logic"](#).

DTC	Items (CONSULT-III screen terms)	Diagnostic item is detected when...	Possible cause
B2634	PASS AIRMIX ACTR SHORT	Air mix door PBR (passenger side) position 95% or less	• Air mix door motor (PBR internal circuit is open or shorted) • A/C auto amp. • Harness and connector (LAN communication line is open or shorted)
B2635	PASS AIRMIX ACTR OPEN	Air mix door PBR (passenger side) position 5% or more	

HAC

### DTC CONFIRMATION PROCEDURE

#### 1. CHECK WITH SELF-DIAGNOSIS FUNCTION OF CONSULT-III

1. Using CONSULT-III, perform "SELF-DIAGNOSIS RESULTS" of HVAC.
2. Check if any DTC No. is displayed in the self-diagnosis results.

#### NOTE:

If DTC is displayed along with DTC U1000 or U1010, first diagnose the DTC U1000 or U1010. Refer to [HAC-43. "DTC Logic"](#) or [HAC-44. "DTC Logic"](#).

Is DTC No. "B2634" or "B2635" displayed?

YES >> Perform trouble diagnosis for the air mix door motor (passenger side). Refer to [HAC-60. "Diagnosis Procedure"](#).

NO >> GO TO 2.

#### 2. FUNCTION INSPECTION

1. Press temperature control "UP" switch (passenger side) until 32°C (90°F) is displayed.
2. Check for warm air at discharge air outlets.
3. Operate the compressor.
4. Press temperature control "DOWN" switch (passenger side) until 18°C (60°F) is displayed.
5. Check for cool air at air discharge outlets.

Does it operate normally?

YES >> INSPECTION END

NO >> Check air mix door motor (passenger side) installation, and repair or replace the malfunctioning parts.

# B2634, B2635 AIR MIX DOOR MOTOR (PASSENGER SIDE)

< DTC/CIRCUIT DIAGNOSIS >

[WITHOUT 7 INCH DISPLAY]

## Diagnosis Procedure

INFOID:000000005514623

### 1. CHECK POWER SUPPLY FOR AIR MIX DOOR MOTOR (PASSENGER SIDE)

Check voltage between air mix door motor (passenger side) harness connector and ground.

(+)		(-)	Voltage
Air mix door motor (passenger side)		—	
Connector	Terminal		
M307	1	Ground	Battery voltage

Is the inspection result normal?

YES >> GO TO 2.

NO >> Repair the harnesses or connectors.

### 2. CHECK SIGNAL FOR AIR MIX DOOR MOTOR (PASSENGER SIDE)

Check the output waveform (LAN signal) between air mix door motor (passenger side) harness connector and ground using an oscilloscope.

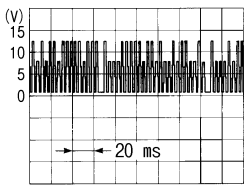
(+)		(-)	Voltage
Air mix door motor (passenger side)		—	
Connector	Terminal		
M307	3	Ground	

Is the inspection result normal?

YES >> GO TO 3.

NO >> Repair the harnesses or connectors.

### 3. CHECK AIR MIX DOOR MOTOR (PASSENGER SIDE) GROUND CIRCUIT

1. Turn ignition switch OFF.
2. Disconnect air mix door motor (passenger side) connector.
3. Check continuity between air mix door motor (passenger side) harness connector and ground.

Air mix door motor (passenger side)		(-)	Continuity
		—	
Connector	Terminal		
M307	2	Ground	Existed

Is the inspection result normal?

YES >> Replace air mix door motor (passenger side).

NO >> Repair harness or connector.

# B2636, B2637, B2638, B2639, B2654, B2655 MODE DOOR MOTOR

< DTC/CIRCUIT DIAGNOSIS >

[WITHOUT 7 INCH DISPLAY]

## B2636, B2637, B2638, B2639, B2654, B2655 MODE DOOR MOTOR

### Description

INFOID:000000005514624

### COMPONENT DESCRIPTION

#### Mode Door Motor

- The mode door motor (1) are attached to the heater & cooling unit assembly.
- It rotates so that air is discharged from the outlet set by the A/C auto amp. Motor rotation is conveyed to a link which activates the mode door.

←: Vehicle front

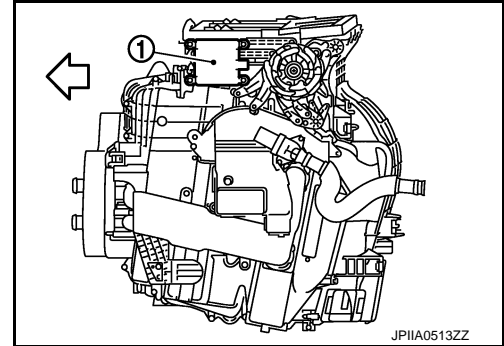

### DTC Logic

INFOID:000000005514625

### DTC DETECTION LOGIC

#### NOTE:

If DTC is displayed along with DTC U1000 or U1010, first diagnose the DTC U1000 or U1010. Refer to [HAC-43. "DTC Logic"](#) or [HAC-44. "DTC Logic"](#).

DTC	Items (CONSULT-III screen terms)	Diagnostic item is detected when...	Possible cause
B2636	DR VENT DOOR FAIL	When the malfunctioning door position is detected at VENT position	<ul style="list-style-type: none"> <li>• Mode door motor (PBR internal circuit is open or shorted)</li> <li>• A/C auto amp.</li> <li>• Harness and connector (LAN communication line is open or shorted)</li> </ul>
B2637	DR B/L DOOR FAIL	When the malfunctioning door position is detected at B/L position	
B2638	DR D/F1 DOOR FAIL	When the malfunctioning door position is detected at FOOT position	
B2639	DR DEF DOOR FAIL	When the malfunctioning door position is detected at DEF position	
B2654	D/F2 DOOR FAIL	When the malfunctioning door position is detected at D/F position	
B2655	B/L2 DOOR FAIL	When the malfunctioning door position is detected at B/L2 position	

### DTC CONFIRMATION PROCEDURE

#### 1. CHECK WITH SELF-DIAGNOSIS FUNCTION OF CONSULT-III

1. Using CONSULT-III, perform "SELF-DIAGNOSIS RESULTS" of HVAC.
2. Check if any DTC No. is displayed in the self-diagnosis results.

#### NOTE:

If DTC is displayed along with DTC U1000 or U1010, first diagnose the DTC U1000 or U1010. Refer to [HAC-43. "DTC Logic"](#) or [HAC-44. "DTC Logic"](#).

Is DTC No. "B2636", "B2637", "B2638", "B2639", "B2654" or "B2655" displayed?

- YES >> Perform trouble diagnosis for the mode door motor. Refer to [HAC-62. "Diagnosis Procedure"](#).
- NO >> GO TO 2.

#### 2. FUNCTION INSPECTION

1. Press MODE switch and DEF switch.
2. Each position indicator should change shape.

# B2636, B2637, B2638, B2639, B2654, B2655 MODE DOOR MOTOR

< DTC/CIRCUIT DIAGNOSIS >

[WITHOUT 7 INCH DISPLAY]

3. Confirm that air discharge comes out according to the air distribution table at below. Refer to [HAC-15](#), "[System Description](#)".

Discharge air flow							
Mode position indication	Condition	Air outlet/distribution					
		VENT			FOOT		DEF
		Front	Upper	Rear	Front	Rear	
	DUAL switch: OFF UPPER VENT switch : ON	81%	8%	11%	—	—	—
		41%	10%	17%	24%	8%	—
		12%	12%	16%	27%	10%	23%
		11%	11%	14%	25%	10%	29%
		11%	11%	12%	—	—	66%

JPIIA0509GB

Discharge air flow							
Mode position indication	Condition	Air outlet/distribution					
		VENT			FOOT		DEF
		Front	Upper	Rear	Front	Rear	
	DUAL switch: OFF UPPER VENT switch : OFF	88%	—	12%	—	—	—
		47%	—	18%	26%	9%	—
		13%	—	17%	33%	12%	25%
		12%	—	16%	28%	12%	32%
		11%	—	15%	—	—	74%

JPIIA0510GB

## NOTE:

Confirm that the compressor clutch is engaged (Sound or visual inspection) and intake door position is at FRE when DEF ( ) or D/F ( ) is selected.

### Does it operate normally?

YES >> INSPECTION END

NO >> Check mode door motor installation, and repair or replace the malfunctioning parts.

## Diagnosis Procedure

INFOID:000000005514626

### 1. CHECK POWER SUPPLY FOR MODE DOOR MOTOR

Check voltage between mode door motor harness connector and ground.

(+)		(-)	Voltage
Mode door motor		—	
Connector	Terminal		
M310	1	Ground	Battery voltage

### Is the inspection result normal?

YES >> GO TO 2.

NO >> Repair harness or connector.

### 2. CHECK SIGNAL FOR MODE DOOR MOTOR

Confirm A/C LAN signal between mode door motor harness connector and ground using an oscilloscope.

# B2636, B2637, B2638, B2639, B2654, B2655 MODE DOOR MOTOR

< DTC/CIRCUIT DIAGNOSIS >

[WITHOUT 7 INCH DISPLAY]

(+)		(-)	Voltage
Mode door motor		—	
Connector	Terminal		
M310	3	Ground	

Is the inspection result normal?

YES >> GO TO 3.

NO >> Repair harness or connector.

### 3.CHECK MODE DOOR MOTOR GROUND CIRCUIT

1. Turn ignition switch OFF.
2. Disconnect mode door motor connector.
3. Check continuity between mode door motor harness connector and ground.

Mode door motor		—	Continuity
Connector	Terminal		
M310	2	Ground	Existed

Is the inspection result normal?

YES >> Replace mode door motor.

NO >> Repair harness or connector.

A  
B  
C  
D  
E  
F  
G  
H  
J  
K  
L  
M  
N  
O  
P

HAC

# B263D, B263E, B263F INTAKE DOOR MOTOR

< DTC/CIRCUIT DIAGNOSIS >

[WITHOUT 7 INCH DISPLAY]

## B263D, B263E, B263F INTAKE DOOR MOTOR

### Description

INFOID:000000005514627

#### COMPONENT DESCRIPTION

Intake Door Motor

- The intake door motor (1) is attached to the blower unit.

←: Vehicle front

- It rotates so that air is drawn from inlets set by the A/C auto amp. Motor rotation is conveyed to a lever which activates the intake door.

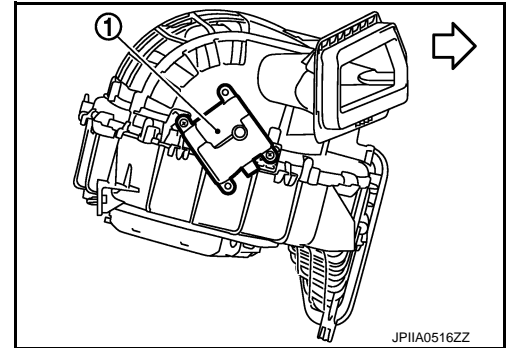

### DTC Logic

INFOID:000000005514628

#### DTC DETECTION LOGIC

##### NOTE:

If DTC is displayed along with DTC U1000 or U1010, first diagnose the DTC U1000 or U1010. Refer to [HAC-43. "DTC Logic"](#) or [HAC-44. "DTC Logic"](#).

DTC	Items (CONSULT-III screen terms)	Diagnostic item is detected when...	Possible cause
B263D	FRE DOOR FAIL	When the malfunctioning intake door position is detected at FRE position	<ul style="list-style-type: none"><li>• Intake door motor (PBR internal circuit is open or shorted)</li><li>• A/C auto amp.</li><li>• Harness and connector (LAN communication line is open or shorted)</li></ul>
B263E	20P FRE DOOR FAIL	When the malfunctioning intake door position is detected at 20%FRE position	
B263F	REC DOOR FAIL	When the malfunctioning intake door position is detected at REC position	

#### DTC CONFIRMATION PROCEDURE

##### 1. CHECK WITH SELF-DIAGNOSIS FUNCTION OF CONSULT-III

1. Using CONSULT-III, perform "SELF-DIAGNOSIS RESULTS" of HVAC.
2. Check if any DTC No. is displayed in the self-diagnosis results.

##### NOTE:

If DTC is displayed along with DTC U1000 or U1010, first diagnose the DTC U1000 or U1010. Refer to [HAC-43. "DTC Logic"](#) or [HAC-44. "DTC Logic"](#).

Is DTC No. "B263D", "B263E" or "B263F" displayed?

- YES >> Perform trouble diagnosis for the intake door motor. Refer to [HAC-65. "Diagnosis Procedure"](#).  
NO >> GO TO 2.

##### 2. FUNCTION INSPECTION

1. Press intake switch.
2. The intake switch indicator is turned ON. (REC position)
3. Listen for intake door position change (Slight change of blower sound can be heard.).
4. Press intake switch again.
5. The intake switch indicator is turned OFF. (FRE position)
6. Listen for intake door position change (Slight change of blower sound can be heard.).

Does it operate normally?

- YES >> INSPECTION END  
NO >> Check intake door motor installation, and repair or replace the malfunctioning parts.



# B263D, B263E, B263F INTAKE DOOR MOTOR

< DTC/CIRCUIT DIAGNOSIS >

[WITHOUT 7 INCH DISPLAY]

## Diagnosis Procedure

INFOID:00000000514629

### 1. CHECK POWER SUPPLY FOR INTAKE DOOR MOTOR

Check voltage between intake door motor harness connector and ground.

(+)		(-)	Voltage
Intake door motor		—	
Connector	Terminal		
M304	1	Ground	Battery voltage

Is the inspection result normal?

YES >> GO TO 2.

NO >> Repair harness or connector.

### 2. CHECK SIGNAL FOR INTAKE DOOR MOTOR

Confirm A/C LAN signal between intake door motor harness connector and ground using an oscilloscope.

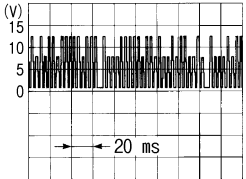
(+)		(-)	Voltage
Intake door motor		—	
Connector	Terminal		
M304	3	Ground	 SJIA1453J

Is the inspection result normal?

YES >> GO TO 3.

NO >> Repair harness or connector.

### 3. CHECK INTAKE DOOR MOTOR GROUND CIRCUIT

1. Turn ignition switch OFF.
2. Disconnect intake door motor connector.
3. Check continuity between intake door motor harness connector and ground.

Intake door motor		(-)	Continuity
Intake door motor		—	
Connector	Terminal		
M304	2	Ground	Existed

Is the inspection result normal?

YES >> Replace intake door motor.

NO >> Repair harness or connector.

A  
B  
C  
D  
E  
F  
G  
H  
I  
J  
K  
L  
M  
N  
O  
P

HAC

# B2661, B2662, B2663 UPPER VENTILATOR DOOR MOTOR

< DTC/CIRCUIT DIAGNOSIS >

[WITHOUT 7 INCH DISPLAY]

## B2661, B2662, B2663 UPPER VENTILATOR DOOR MOTOR

### Description

INFOID:000000005514630

#### COMPONENT DESCRIPTION

Upper Ventilator Door Motor

- The upper ventilator door motor (1) are attached to the heater & cooling unit assembly.

←: Vehicle front

- Upper ventilator door motor operates by UPPER VENT switch ON/OFF when the DEF switch is OFF.
- Motor rotation is conveyed to a link which activates the upper ventilator door.

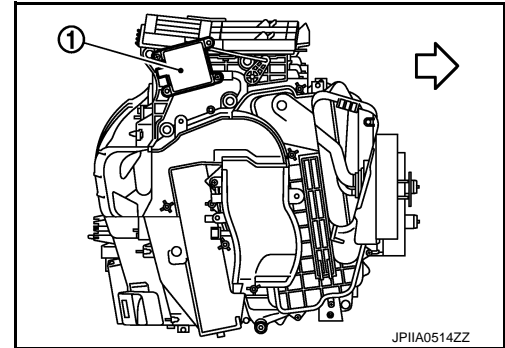

### DTC Logic

INFOID:000000005514631

#### DTC DETECTION LOGIC

##### NOTE:

If DTC is displayed along with DTC U1000 or U1010, first diagnose the DTC U1000 or U1010. Refer to [HAC-43. "DTC Logic"](#) or [HAC-44. "DTC Logic"](#).

DTC	Items (CONSULT-III screen terms)	Diagnostic item is detected when...	Possible cause
B2661	UPPER VENT DOOR OPEN POSI FAIL	When the malfunctioning upper ventilator door position is detected at open position.	<ul style="list-style-type: none"><li>• Upper ventilator door motor (PBR internal circuit is open or shorted)</li><li>• A/C auto amp.</li><li>• Harness and connector (LAN communication line is open or shorted)</li></ul>
B2662	UPPER VENT DOOR MID POSI FAIL	When the malfunctioning upper ventilator door position is detected at middle position.	
B2663	UPPER VENT DOOR SHUT POSI FAIL	When the malfunctioning upper ventilator door position is detected at shut position.	

#### DTC CONFIRMATION PROCEDURE

##### 1. CHECK WITH SELF-DIAGNOSIS FUNCTION OF CONSULT-III

1. Using CONSULT-III, perform "SELF-DIAGNOSIS RESULTS" of HVAC.
2. Check if any DTC No. is displayed in the self-diagnosis results.

##### NOTE:

If DTC is displayed along with DTC U1000 or U1010, first diagnose the DTC U1000 or U1010. Refer to [HAC-43. "DTC Logic"](#) or [HAC-44. "DTC Logic"](#).

Is DTC No. "B2661", "B2662" or "B2663" displayed?

YES >> Perform trouble diagnosis for the upper ventilator door motor. Refer to [HAC-67. "Diagnosis Procedure"](#).

NO >> GO TO 2.

##### 2. FUNCTION INSPECTION

1. Press the UPPER VENT switch.
2. The UPPER VENT switch indicator is turned ON.

# B2661, B2662, B2663 UPPER VENTILATOR DOOR MOTOR

< DTC/CIRCUIT DIAGNOSIS >

[WITHOUT 7 INCH DISPLAY]

3. Check that the air blown from UPPER VENT does not greatly deviate from the air mix ratio.

Discharge air flow							
Mode position indication	Condition	Air outlet/distribution					
		VENT			FOOT		DEF
		Front	Upper	Rear	Front	Rear	
	DUAL switch: OFF UPPER VENT switch : ON	81%	8%	11%	—	—	—
		41%	10%	17%	24%	8%	—
		12%	12%	16%	27%	10%	23%
		11%	11%	14%	25%	10%	29%
		11%	11%	12%	—	—	66%

JPIIA0509GB

4. Press the UPPER VENT switch again.
5. The UPPER VENT switch indicator is turned OFF.
6. The air blown from UPPER VENT stops.

Does it operate normally?

YES >> INSPECTION END

NO >> Check upper ventilator door motor installation, and repair or replace the malfunctioning parts.

## Diagnosis Procedure

INFOID:000000005514632

### 1.CHECK POWER SUPPLY FOR UPPER VENTILATOR DOOR MOTOR

Check voltage between upper ventilator door motor harness connector and ground.

(+)		(-)	Voltage
Upper ventilator door motor		—	
Connector	Terminal		
M308	1	Ground	Battery voltage

Is the inspection result normal?

YES >> GO TO 2.

NO >> Repair harness or connector.

### 2.CHECK SIGNAL FOR UPPER VENTILATOR DOOR MOTOR

Confirm A/C LAN signal between upper ventilator door motor harness connector and ground using an oscilloscope.

(+)		(-)	Voltage
Upper ventilator door motor		—	
Connector	Terminal		
M308	3	Ground	

SJIA1453J

Is the inspection result normal?

YES >> GO TO 3.

NO >> Repair harness or connector.

# B2661, B2662, B2663 UPPER VENTILATOR DOOR MOTOR

< DTC/CIRCUIT DIAGNOSIS >

[WITHOUT 7 INCH DISPLAY]

## 3. CHECK UPPER VENTILATOR DOOR MOTOR GROUND CIRCUIT

1. Turn ignition switch OFF.
2. Disconnect upper ventilator door motor connector.
3. Check continuity between upper ventilator door motor harness connector and ground.

Upper ventilator door motor		—	Continuity
Connector	Terminal		
M308	2	Ground	Existed

Is the inspection result normal?

- YES >> Replace upper ventilator door motor.  
NO >> Repair harness or connector.

# BLOWER MOTOR

< DTC/CIRCUIT DIAGNOSIS >

[WITHOUT 7 INCH DISPLAY]

## BLOWER MOTOR

### Description

INFOID:000000005514633

### COMPONENT DESCRIPTION

#### Brush-less Motor

The blower motor utilizes a brush-less motor with a rotating magnet. Quietness is improved over previous motors where the brush was the point of contact and the coil rotated.

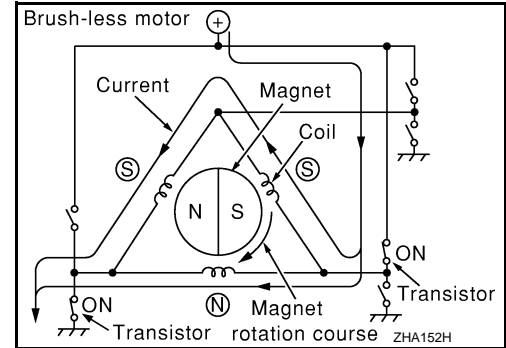

#### Blower Motor Circuit

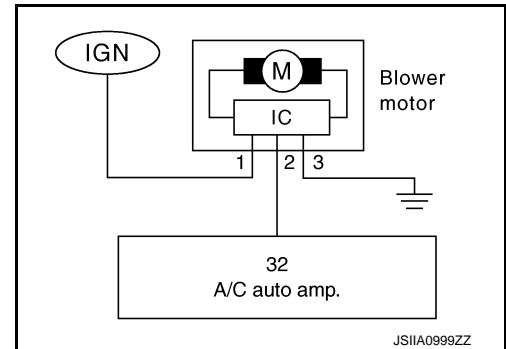

### Component Function Check

INFOID:000000005514634

#### 1. CHECK OPERATION

1. Warm up the engine.
2. Operate the fan control dial. Check that the fan speed and indicator are switched for all fan speeds.

#### Does it operate normally?

YES >> INSPECTION END

NO >> Perform trouble diagnosis for the blower motor. Refer to [HAC-69, "Diagnosis Procedure"](#).

### Diagnosis Procedure

INFOID:000000005514635

#### 1. CHECK WITH SELF-DIAGNOSIS FUNCTION OF CONSULT-III

1. Using CONSULT-III, perform "SELF-DIAGNOSIS RESULTS" of HVAC.
2. Check if any DTC No. is displayed in the self-diagnosis results.

#### **NOTE:**

If DTC is displayed along with DTC U1000 or U1010, first diagnose the DTC U1000 or U1010. Refer to [HAC-43, "DTC Logic"](#) or [HAC-44, "DTC Logic"](#).

#### Is any DTC No. displayed?

YES >> Perform the diagnosis that is applicable to the sensor and actuator. Refer to [HAC-106, "DTC Index"](#).

NO >> GO TO 2.

#### 2. CHECK WITH ACTIVE TEST OF CONSULT-III

1. Using CONSULT-III, perform "HVAC TEST" "ACTIVE TEST" of HVAC to check each output device. Refer to [HAC-39, "CONSULT-III Function"](#).

#### **NOTE:**

Perform the ACTIVE TEST after starting the engine because the compressor is operated.

# BLOWER MOTOR

< DTC/CIRCUIT DIAGNOSIS >

[WITHOUT 7 INCH DISPLAY]

- Check that the blower motor control signal changes according to each indicator signal.

	Test item						
	MODE 1	MODE 2	MODE 3	MODE 4	MODE 5	MODE 6	MODE 7
Mode door position	VENT1	VENT2	B/L1	B/L2	FOOT	D/F	DEF
Intake door position	REC	REC	20%FRE	20%FRE	FRE	FRE	FRE
Air mix door position (driver & passenger side)	FULL COLD	FULL HOT	FULL COLD	FULL HOT	FULL HOT	FULL HOT	FULL HOT
Blower motor duty ratio	35%	35%	61%	61%	81%	81%	35%
Compressor (Magnet clutch)	ON	ON	ON	ON	OFF	OFF	ON
Upper ventilator door	OPEN	SHUT	OPEN	SHUT	SHUT	SHUT	SHUT

**NOTE:**

Perform the inspection of each output device after starting the engine because the compressor is operated.

Does it operate normally?

- YES >> INSPECTION END  
 NO >> GO TO 3.

### 3.CHECK POWER SUPPLY FOR BLOWER MOTOR

- Disconnect blower motor connector.
- Turn ignition switch ON.
- Check voltage between blower motor harness connector and ground.

(+)		(-)	Voltage
Blower motor		—	
Connector	Terminal		
M98	1	Ground	

Is the inspection result normal?

- YES >> GO TO 4.  
 NO >> GO TO 7.

### 4.CHECK BLOWER MOTOR GROUND CIRCUIT

- Turn ignition switch OFF.
- Check continuity between blower motor harness connector and ground.

Blower motor		—	Continuity
Connector	Terminal		
M98	3	Ground	Existed

Is the inspection result normal?

- YES >> GO TO 5.  
 NO >> Repair harness or connector.

### 5.CHECK BLOWER MOTOR CIRCUIT CONTINUITY

- Disconnect A/C auto amp. connector.
- Check continuity between blower motor harness connector and A/C auto amp. harness connector.

Blower motor		A/C auto amp.		Continuity
Connector	Terminal	Connector	Terminal	
M98	2	M50	32	Existed

Is the inspection result normal?

- YES >> GO TO 6.

# BLOWER MOTOR

< DTC/CIRCUIT DIAGNOSIS >

[WITHOUT 7 INCH DISPLAY]

NO >> Repair harness or connector.

## 6. CHECK A/C AUTO AMP. OUTPUT SIGNAL

1. Reconnect blower motor connector and A/C auto amp. connector.
2. Turn ignition switch ON.
3. Set MODE switch to the VENT position.
4. Check the output waveform between blower motor harness connector and ground using an oscilloscope, while varying the fan speed from 1 to 7.

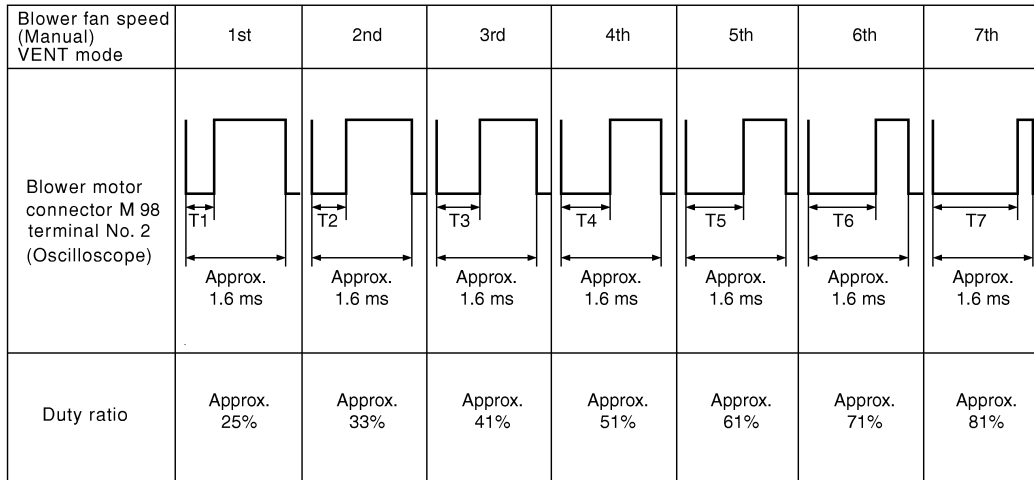

NOTE: Duty ratio =  $\frac{T_x}{\text{Approx. } 1.6 \text{ ms}} \times 100 (\%)$

JPIIA0616GB

Is the inspection result normal?

- YES >> Replace the blower motor.  
 NO >> Replace the A/C auto amp.

## 7. CHECK POWER VOLTAGE OF BLOWER RELAY

1. Turn the ignition switch OFF.
2. Remove the blower relay. Refer to [PG-113, "Fuse, Connector and Terminal Arrangement"](#).
3. Turn the ignition switch ON.
4. Check the voltage between blower relay fuse block side terminal and ground. Refer to [PG-113, "Fuse, Connector and Terminal Arrangement"](#) for relay terminal assignment.

(+)	(-)	Voltage
Blower relay	—	
1	Ground	Battery voltage
3		

Is the inspection result normal?

- YES >> GO TO 8.  
 NO >> Inspection the power supply circuit. Refer to [PG-67, "Wiring Diagram - IGNITION POWER SUPPLY -"](#).

## 8. CHECK BLOWER RELAY

1. Turn the ignition switch OFF.
2. Install the blower relay. Refer to [PG-113, "Fuse, Connector and Terminal Arrangement"](#).
3. Turn the ignition switch ON.
4. Check the operating sound of blower relay.

Is the inspection result normal?

- YES >> GO TO 9.  
 NO >> Replace the blower relay.

## 9. CHECK FUSE

Check 15A fuses (Nos. 21 and 22).

**NOTE:**

A  
B  
C  
D  
E  
F  
G  
H

HAC

J  
K  
L  
M

N  
O  
P

# BLOWER MOTOR

< DTC/CIRCUIT DIAGNOSIS >

[WITHOUT 7 INCH DISPLAY]

Refer to [PG-113, "Fuse, Connector and Terminal Arrangement"](#) for fuse location.

Is the inspection result normal?

YES >> Repair the harnesses or connectors.

NO >> Replace the fuse after repairing the applicable circuit.

## Component Inspection

INFOID:000000005514636

### 1. CHECK BLOWER MOTOR

1. Remove the blower motor. Refer to [VTL-33, "Exploded View"](#).

2. Check that the blower motor rotates smoothly.

Is the inspection result normal?

YES >> INSPECTION END

NO >> Replace blower motor.



## MAGNET CLUTCH

### Description

INFOID:000000005514637

The magnet clutch drives the compressor, by an IPDM E/R signal.

### Component Function Check

INFOID:000000005514638

#### 1. FUNCTION INSPECTION

1. Press AUTO switch.
2. "AUTO" is indicated on the display.
3. Press the A/C switch.
4. Check that the indicator of the A/C switch turns on. Check visually and by sound that the compressor is operating (the discharge air temperature or fan speed varies depending on the ambient temperature, in-vehicle temperature, and temperature setting).
5. Press the A/C switch again.
6. Check that the indicator of the A/C switch turns OFF. Check visually and by sound that the compressor stops.

#### Does it operate normally?

YES >> INSPECTION END

NO >> Perform trouble diagnosis for the compressor. Refer to [HAC-73, "Diagnosis Procedure"](#).

### Diagnosis Procedure

INFOID:000000005514639

#### 1. INSPECTION IN AUTO ACTIVE TEST MODE

Perform "AUTO ACTIVE TEST". Refer to [PCS-10, "Diagnosis Description"](#).

#### Does it operate normally?

YES >> GO TO 5.

NO >> GO TO 2.

#### 2. CHECK MAGNET CLUTCH

1. Turn the ignition switch OFF.
2. Disconnect the magnet clutch connector.
3. Directly apply the battery voltage to the magnet clutch. Check for operation visually and by sound.

#### Does it operate normally?

YES >> GO TO 3.

NO >> Replace the compressor.

#### 3. CHECK MAGNET CLUTCH CIRCUIT CONTINUITY

1. Turn the ignition switch OFF.
2. Disconnect IPDM E/R connector.
3. Check continuity between magnet clutch harness connector and IPDM E/R harness connector.

IPDM E/R		Compressor		Continuity
Connector	Terminal	Connector	Terminal	
F12	48	F18	1	Existed

#### Is the inspection result normal?

YES >> GO TO 4.

NO >> Repair harness or connector.

#### 4. CHECK FUSE

Check 10A fuse (No. 49).

#### **NOTE:**

Refer to [PG-115, "Fuse, Connector and Terminal Arrangement"](#) for fuse location.

#### Is the inspection result normal?

YES >> Replace IPDM E/R.

# MAGNET CLUTCH

[WITHOUT 7 INCH DISPLAY]

< DTC/CIRCUIT DIAGNOSIS >

NO >> Replace the fuse after repairing the applicable circuit.

## 5. CHECK WITH SELF-DIAGNOSIS FUNCTION OF CONSULT-III

1. Using CONSULT-III, perform "SELF-DIAGNOSIS RESULTS" of HVAC.
2. Check if any DTC No. is displayed in the self-diagnosis results.

### NOTE:

If DTC is displayed along with DTC U1000 or U1010, first diagnose the DTC U1000 or U1010. Refer to [HAC-43. "DTC Logic"](#) or [HAC-44. "DTC Logic"](#).

Is any DTC No. displayed?

YES >> Perform the diagnosis that is applicable to the sensor and actuator. Refer to [HAC-106. "DTC Index"](#).

NO >> GO TO 6.

## 6. CHECK A/C AUTO AMP. INPUT SIGNAL

Using CONSULT-III, check "On/Off" of "COMP REQ SIG" and "FAN REQ SIG" in "DATA MONITOR" of HVAC. Refer to [HAC-39. "CONSULT-III Function"](#).

A/C SWITCH ON	: COMP REQ SIG On
A/C SWITCH OFF	: COMP REQ SIG Off
FAN CONTROL DIAL ON	: FAN REQ SIG On
FAN CONTROL DIAL OFF	: FAN REQ SIG Off

Is the inspection result normal?

YES >> GO TO 7.

NO >> Replace A/C auto amp.

## 7. CHECK REFRIGERANT PRESSURE SENSOR

Check refrigerant pressure sensor. Refer to [EC-457. "Diagnosis Procedure"](#).

Is the inspection result normal?

YES >> INSPECTION END

NO >> Repair or replace malfunctioning parts.

# A/C CONTROL SIGNAL CIRCUIT

< DTC/CIRCUIT DIAGNOSIS >

[WITHOUT 7 INCH DISPLAY]

## A/C CONTROL SIGNAL CIRCUIT

### Diagnosis Procedure

INFOID:000000005514640

#### 1. CHECK WITH SELF-DIAGNOSIS FUNCTION OF CONSULT-III

1. Using CONSULT-III, perform "SELF-DIAGNOSIS RESULTS" of HVAC.
2. Check if any DTC No. is displayed in the self-diagnosis results.

**NOTE:**

If DTC is displayed along with DTC U1000 or U1010, first diagnose the DTC U1000 or U1010. Refer to [HAC-43. "DTC Logic"](#) or [HAC-44. "DTC Logic"](#).

Is any DTC No. displayed?

YES >> Perform the diagnosis that is applicable to the sensor and actuator. Refer to [HAC-106. "DTC Index"](#).

NO >> GO TO 2.

#### 2. CHECK TX (A/C CONTROL → A/C AUTO AMP.) CIRCUIT CONTINUITY

1. Disconnect the A/C control and the A/C auto amp. connector.
2. Check continuity between A/C control harness connector and A/C auto amp. harness connector.

A/C control		A/C auto amp.		Continuity
Connector	Terminal	Connector	Terminal	
M95	4	M50	7	Existed

3. Check continuity between A/C control harness connector and ground.

A/C control		—	Continuity
Connector	Terminal		
M95	4	Ground	Not existed

Is the inspection result normal?

YES >> GO TO 3.

NO >> Repair harness or connector.

#### 3. CHECK RX (A/C AUTO AMP. → A/C CONTROL) CIRCUIT CONTINUITY

1. Disconnect the A/C control and the A/C auto amp. connector.
2. Check continuity between A/C control harness connector and A/C auto amp. harness connector.

A/C control		A/C auto amp.		Continuity
Connector	Terminal	Connector	Terminal	
M95	3	M50	6	Existed

3. Check continuity between A/C control harness connector and ground.

A/C control		—	Continuity
Connector	Terminal		
M95	3	Ground	Not existed

Is the inspection result normal?

YES >> Perform trouble diagnosis for the A/C control. Refer to [HAC-77. "A/C CONTROL : Diagnosis Procedure"](#).

NO >> Repair harness or connector.

A  
B  
C  
D  
E  
F  
G  
H  
J  
K  
L  
M  
N  
O  
P

HAC

# POWER SUPPLY AND GROUND CIRCUIT

< DTC/CIRCUIT DIAGNOSIS >

[WITHOUT 7 INCH DISPLAY]

## POWER SUPPLY AND GROUND CIRCUIT

### A/C AUTO AMP.

#### A/C AUTO AMP. : Description

INFOID:000000005514641

#### COMPONENT DESCRIPTION

A/C Auto Amp. (Air Conditioner Automatic Amplifier)

The A/C auto amp. (1) has a built-in microcomputer that processes information sent from various sensors needed for air conditioner operation. The air mix door motor(s), the mode door motor, the intake door motor, the upper ventilator door motor, the blower motor and the compressor are then controlled.

When the various switches and temperature control switch are operated, data is input to the A/C auto amp. from the A/C control.

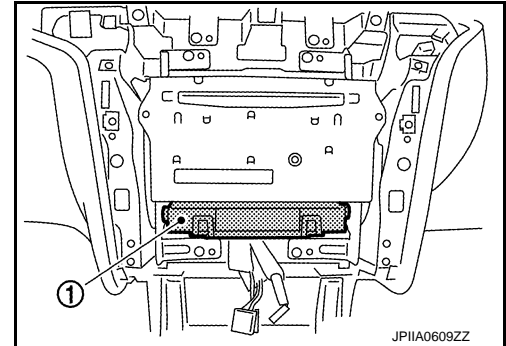

#### Power Supply and Ground Circuit for A/C Auto Amp.

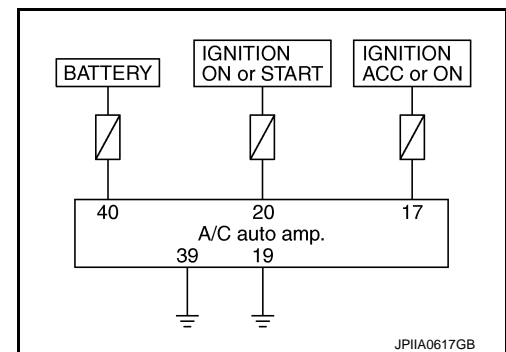

#### A/C AUTO AMP. : Component Function Check

INFOID:000000005514642

##### 1. CHECK OPERATION

1. Press the AUTO switch, and then check that "AUTO" is shown on the display.
2. Operate the temperature control switch (driver side). Check that the fan speed or outlet changes. (The discharge air temperature or fan speed varies depending on the ambient temperature, in-vehicle temperature, and temperature setting.)

##### Does it operate normally?

YES >> INSPECTION END

NO >> Perform trouble diagnosis for the A/C system. Refer to [HAC-76. "A/C AUTO AMP. : Diagnosis Procedure"](#).

#### A/C AUTO AMP. : Diagnosis Procedure

INFOID:000000005514643

##### 1. CHECK A/C AUTO AMP. POWER SUPPLY CIRCUIT

1. Disconnect the A/C auto amp. connector.
2. Check voltage between A/C auto amp. harness connector and ground.

# POWER SUPPLY AND GROUND CIRCUIT

< DTC/CIRCUIT DIAGNOSIS >

[WITHOUT 7 INCH DISPLAY]

(+)		(-)	Voltage		
A/C auto amp.		—	Ignition switch position		
Connector	Terminal		OFF	ACC	ON
M50	17	Ground	Approx. 0 V	Battery voltage	Battery voltage
	20		Approx. 0 V	Approx. 0 V	Battery voltage
	40		Battery voltage	Battery voltage	Battery voltage

Is the inspection result normal?

- YES >> GO TO 3.  
NO >> GO TO 2.

## 2.CHECK FUSE

Check 10A fuses [Nos. 3, 6 and 19, located in the fuse block (J/B)].

**NOTE:**

Refer to [PG-113, "Fuse, Connector and Terminal Arrangement"](#).

Is the inspection result normal?

- YES >> Repair the harnesses or connectors.  
NO >> Replace the fuse after repairing the applicable circuit.

## 3.CHECK A/C AUTO AMP. CIRCUIT CONTINUITY

1. Turn ignition switch OFF.
2. Check continuity between A/C auto amp. harness connector and ground.

A/C auto amp.		(-)	Continuity
Connector	Terminal	—	Ground
M50	19		
	39		

Is the inspection result normal?

- YES >> Replace the A/C auto amp.  
NO >> Repair the harnesses or connectors.

## A/C CONTROL

### A/C CONTROL : Diagnosis Procedure

INFOID:000000005514644

## 1.CHECK A/C CONTROL POWER SUPPLY CIRCUIT

1. Disconnect the A/C control connector.
2. Turn ignition switch ON.
3. Check voltage between A/C control harness connector and ground.

(+)		(-)	Voltage
A/C control		—	Ground
Connector	Terminal		
M95	1	Ground	Battery voltage

Is the inspection result normal?

- YES >> GO TO 2.  
NO >> Repair the harnesses or connectors.

## 2.CHECK A/C CONTROL CIRCUIT CONTINUITY

1. Turn ignition switch OFF.
2. Check continuity between A/C control harness connector and ground.

# POWER SUPPLY AND GROUND CIRCUIT

< DTC/CIRCUIT DIAGNOSIS >

[WITHOUT 7 INCH DISPLAY]

A/C control		—	Continuity
Connector	Terminal		
M95	2	Ground	Existed

Is the inspection result normal?

YES >> Replace the A/C control.

NO >> Repair the harnesses or connectors.

## A/C DISPLAY

### A/C DISPLAY : Diagnosis Procedure

INFOID:000000005514645

#### 1. CHECK A/C DISPLAY POWER SUPPLY CIRCUIT

1. Disconnect the A/C display connector.
2. Turn ignition switch ON.
3. Check voltage between A/C display harness connector and ground.

(+)		(-)		Voltage
A/C display		—		
Connector	Terminal			
M16	6	Ground		Battery voltage

Is the inspection result normal?

YES >> GO TO 2.

NO >> Repair the harnesses or connectors.

#### 2. CHECK A/C DISPLAY CIRCUIT CONTINUITY

1. Turn ignition switch OFF.
2. Check continuity between A/C display harness connector and ground.

A/C display		—	Continuity
Connector	Terminal		
M16	1	Ground	Existed

Is the inspection result normal?

YES >> Replace the A/C display.

NO >> Repair the harnesses or connectors.

# ECU DIAGNOSIS INFORMATION

## ECM

### Reference Value

INFOID:000000005683188

### VALUES ON THE DIAGNOSIS TOOL

#### Remarks:

- Specification data are reference values.
- Specification data are output/input values which are detected or supplied by the ECM at the connector.
- \* Specification data may not be directly related to their components signals/values/operations.

I.e. Adjust ignition timing with a timing light before monitoring IGN TIMING, because the monitor may show the specification data in spite of the ignition timing not being adjusted to the specification data. This IGN TIMING monitors the data calculated by the ECM according to the signals input from the camshaft position sensor and other ignition timing related sensors.

Monitor Item	Condition		Values/Status
ENG SPEED	Run engine and compare CONSULT-III value with the tachometer indication.		Almost the same speed as the tachometer indication.
MAS A/F SE-B1	See <a href="#">EC-126, "Description"</a> .		
B/FUEL SCHDL	See <a href="#">EC-126, "Description"</a> .		
A/F ALPHA-B1	See <a href="#">EC-126, "Description"</a> .		
A/F ALPHA-B2	See <a href="#">EC-126, "Description"</a> .		
COOLAN TEMP/S	• Engine: After warming up		More than 70°C (158°F)
A/F SEN1 (B1)	• Engine: After warming up	Maintaining engine speed at 2,000 rpm	Fluctuates around 2.2 V
A/F SEN1 (B2)	• Engine: After warming up	Maintaining engine speed at 2,000 rpm	Fluctuates around 2.2 V
HO2S2 (B1)	<ul style="list-style-type: none"> <li>• Revving engine from idle to 3,000 rpm quickly after the following conditions are met.</li> <li>- Engine: After warming up</li> <li>- After keeping engine speed between 3,500 and 4,000 rpm for 1 minute and at idle for 1 minute under no load</li> </ul>		0 - 0.3 V ↔ Approx. 0.6 - 1.0 V
HO2S2 (B2)	<ul style="list-style-type: none"> <li>• Revving engine from idle to 3,000 rpm quickly after the following conditions are met.</li> <li>- Engine: After warming up</li> <li>- After keeping engine speed between 3,500 and 4,000 rpm for 1 minute and at idle for 1 minute under no load</li> </ul>		0 - 0.3 V ↔ Approx. 0.6 - 1.0 V
HO2S2 MNTR (B1)	<ul style="list-style-type: none"> <li>• Revving engine from idle to 3,000 rpm quickly after the following conditions are met.</li> <li>- Engine: After warming up</li> <li>- After keeping engine speed between 3,500 and 4,000 rpm for 1 minute and at idle for 1 minute under no load</li> </ul>		LEAN ↔ RICH
HO2S2 MNTR (B2)	<ul style="list-style-type: none"> <li>• Revving engine from idle to 3,000 rpm quickly after the following conditions are met.</li> <li>- Engine: After warming up</li> <li>- After keeping engine speed between 3,500 and 4,000 rpm for 1 minute and at idle for 1 minute under no load</li> </ul>		LEAN ↔ RICH
VHCL SPEED SE	• Turn drive wheels and compare CONSULT-III value with the speedometer indication.		Almost the same speed as speedometer indication
BATTERY VOLT	• Ignition switch: ON (Engine stopped)		11 - 14 V
ACCEL SEN 1	• Ignition switch: ON (Engine stopped)	Accelerator pedal: Fully released	0.5 - 1.0 V
		Accelerator pedal: Fully depressed	4.2 - 4.8 V
ACCEL SEN 2*1	• Ignition switch: ON (Engine stopped)	Accelerator pedal: Fully released	0.5 - 1.0 V
		Accelerator pedal: Fully depressed	4.2 - 4.8 V

# ECM

< ECU DIAGNOSIS INFORMATION >

[WITHOUT 7 INCH DISPLAY]

Monitor Item	Condition		Values/Status
TP SEN 1-B1	<ul style="list-style-type: none"> <li>Ignition switch: ON (Engine stopped)</li> <li>Selector lever: D position</li> </ul>	Accelerator pedal: Fully released	More than 0.36 V
		Accelerator pedal: Fully depressed	Less than 4.75 V
TP SEN 2-B1*1	<ul style="list-style-type: none"> <li>Ignition switch: ON (Engine stopped)</li> <li>Selector lever: D position</li> </ul>	Accelerator pedal: Fully released	More than 0.36 V
		Accelerator pedal: Fully depressed	Less than 4.75 V
FUEL T/TMP SE	<ul style="list-style-type: none"> <li>Ignition switch: ON</li> </ul>		Indicates fuel tank temperature
INT/A TEMP SE	<ul style="list-style-type: none"> <li>Ignition switch: ON</li> </ul>		Indicates intake air temperature
EVAP SYS PRES	<ul style="list-style-type: none"> <li>Ignition switch: ON</li> </ul>		Approx. 1.8 - 4.8 V
FUEL LEVEL SE	<ul style="list-style-type: none"> <li>Ignition switch: ON</li> </ul>		Depending on fuel level of fuel tank
START SIGNAL	<ul style="list-style-type: none"> <li>Ignition switch: ON → START → ON</li> </ul>		OFF → ON → OFF
CLSD THL POS	<ul style="list-style-type: none"> <li>Ignition switch: ON (Engine stopped)</li> </ul>	Accelerator pedal: Fully released	ON
		Accelerator pedal: Slightly depressed	OFF
AIR COND SIG	<ul style="list-style-type: none"> <li>Engine: After warming up, idle the engine</li> </ul>	Air conditioner switch: OFF	OFF
		Air conditioner switch: ON (Compressor operates.)	ON
P/N POSI SW	<ul style="list-style-type: none"> <li>Ignition switch: ON</li> </ul>	Selector lever: P or N position	ON
		Selector lever: Except above position	OFF
PW/ST SIGNAL	<ul style="list-style-type: none"> <li>Engine: After warming up, idle the engine</li> </ul>	Steering wheel: Not being turned	OFF
		Steering wheel: Being turned	ON
LOAD SIGNAL	<ul style="list-style-type: none"> <li>Ignition switch: ON</li> </ul>	Rear window defogger switch: ON and/or Lighting switch: 2nd position	ON
		Rear window defogger switch and lighting switch: OFF	OFF
IGNITION SW	<ul style="list-style-type: none"> <li>Ignition switch: ON → OFF → ON</li> </ul>		ON → OFF → ON
HEATER FAN SW	<ul style="list-style-type: none"> <li>Engine: After warming up, idle the engine</li> </ul>	Heater fan switch: ON	ON
		Heater fan switch: OFF	OFF
BRAKE SW	<ul style="list-style-type: none"> <li>Ignition switch: ON</li> </ul>	Brake pedal: Fully released	OFF
		Brake pedal: Slightly depressed	ON
INJ PULSE-B1	<ul style="list-style-type: none"> <li>Engine: After warming up</li> <li>Selector lever: P or N position</li> <li>Air conditioner switch: OFF</li> <li>No load</li> </ul>	Idle	2.0 - 3.0 msec
		2,000 rpm	1.9 - 2.9 msec
INJ PULSE-B2	<ul style="list-style-type: none"> <li>Engine: After warming up</li> <li>Selector lever: P or N position</li> <li>Air conditioner switch: OFF</li> <li>No load</li> </ul>	Idle	2.0 - 3.0 msec
		2,000 rpm	1.9 - 2.9 msec
IGN TIMING	<ul style="list-style-type: none"> <li>Engine: After warming up</li> <li>Selector lever: P or N position</li> <li>Air conditioner switch: OFF</li> <li>No load</li> </ul>	Idle	7 - 17°BTDC
		2,000 rpm	25 - 45°BTDC
CAL/LD VALUE	<ul style="list-style-type: none"> <li>Engine: After warming up</li> <li>Selector lever: P or N position</li> <li>Air conditioner switch: OFF</li> <li>No load</li> </ul>	Idle	5 - 35%
		2,500 rpm	5 - 35%
MASS AIRFLOW	<ul style="list-style-type: none"> <li>Engine: After warming up</li> <li>Selector lever: P or N position</li> <li>Air conditioner switch: OFF</li> <li>No load</li> </ul>	Idle	2.0 - 6.0 g·m/s
		2,500 rpm	7.0 - 20.0 g·m/s



# ECM

< ECU DIAGNOSIS INFORMATION >

[WITHOUT 7 INCH DISPLAY]

Monitor Item	Condition		Values/Status
PURG VOL C/V	<ul style="list-style-type: none"> <li>Engine: After warming up</li> <li>Selector lever: P or N position</li> <li>Air conditioner switch: OFF</li> <li>No load</li> </ul>	Idle (Accelerator pedal: Not depressed even slightly, after engine starting.)	0%
		2,000 rpm	—
INT/V TIM (B1)	<ul style="list-style-type: none"> <li>Engine: After warming up</li> <li>Selector lever: P or N position</li> <li>Air conditioner switch: OFF</li> <li>No load</li> </ul>	Idle	-5 - 5°C
		2,000 rpm	Approx. 0 - 30°C
INT/V TIM (B2)	<ul style="list-style-type: none"> <li>Engine: After warming up</li> <li>Selector lever: P or N position</li> <li>Air conditioner switch: OFF</li> <li>No load</li> </ul>	Idle	-5 - 5°C
		2,000 rpm	Approx. 0 - 30°C
INT/V SOL (B1)	<ul style="list-style-type: none"> <li>Engine: After warming up</li> <li>Selector lever: P or N position</li> <li>Air conditioner switch: OFF</li> <li>No load</li> </ul>	Idle	0 - 2%
		2,000 rpm	Approx. 0 - 50%
INT/V SOL (B2)	<ul style="list-style-type: none"> <li>Engine: After warming up</li> <li>Selector lever: P or N position</li> <li>Air conditioner switch: OFF</li> <li>No load</li> </ul>	Idle	0 - 2%
		2,000 rpm	Approx. 0 - 50%
VIAS S/V-1	<ul style="list-style-type: none"> <li>Engine: After warming up</li> <li>Selector lever: P or N position</li> <li>Air conditioner switch: OFF</li> <li>No load</li> </ul>	When revving engine up to 5,000 rpm quickly	OFF → ON → OFF
VIAS S/V-2	<ul style="list-style-type: none"> <li>Engine: After warming up</li> <li>Selector lever: P or N position</li> <li>Air conditioner switch: OFF</li> <li>No load</li> </ul>	When revving engine up to 5,000 rpm quickly	OFF → ON → OFF
AIR COND RLY	<ul style="list-style-type: none"> <li>Engine: After warming up, idle the engine</li> </ul>	Air conditioner switch: OFF	OFF
		Air conditioner switch: ON (Compressor operates)	ON
ENGINE MOUNT	<ul style="list-style-type: none"> <li>Engine: After warming up</li> </ul>	Below 950 rpm	IDLE
		Above 950 rpm	TRVL
FUEL PUMP RLY	<ul style="list-style-type: none"> <li>For 1 second after turning ignition switch: ON</li> <li>Engine running or cranking</li> </ul>		ON
		<ul style="list-style-type: none"> <li>Except above</li> </ul>	OFF
VENT CONT/V	<ul style="list-style-type: none"> <li>Ignition switch: ON</li> </ul>		OFF
THRTL RELAY	<ul style="list-style-type: none"> <li>Ignition switch: ON</li> </ul>		ON
COOLING FAN	<ul style="list-style-type: none"> <li>Engine: After warming up, idle the engine</li> <li>Air conditioner switch: OFF</li> </ul>	Engine coolant temperature: 97°C (206°F) or less	OFF
		Engine coolant temperature: Between 98°C (208°F) and 99°C (210°F)	LOW
		Engine coolant temperature: Between 100°C (212°F) and 104°C (219°F)	MID
		Engine coolant temperature: 105°C (221°F) or more	HI
HO2S2 HTR (B1)	<ul style="list-style-type: none"> <li>Engine speed: Below 3,600 rpm after the following conditions are met.                             <ul style="list-style-type: none"> <li>Engine: After warming up</li> <li>Keeping the engine speed between 3,500 and 4,000 rpm for 1 minute and at idle for 1 minute under no load</li> </ul> </li> <li>Engine speed: Above 3,600 rpm</li> </ul>		ON
			OFF

A  
B  
C  
D  
E  
F  
G  
H  
HAC  
J  
K  
L  
M  
N  
O  
P

# ECM

< ECU DIAGNOSIS INFORMATION >

[WITHOUT 7 INCH DISPLAY]

Monitor Item	Condition		Values/Status
HO2S2 HTR (B2)	<ul style="list-style-type: none"> <li>Engine speed: Below 3,600 rpm after the following conditions are met.                             <ul style="list-style-type: none"> <li>Engine: After warming up</li> <li>Keeping the engine speed between 3,500 and 4,000 rpm for 1 minute and at idle for 1 minute under no load</li> </ul> </li> </ul>		ON
	<ul style="list-style-type: none"> <li>Engine speed: Above 3,600 rpm</li> </ul>		OFF
I/P PULLY SPD	<ul style="list-style-type: none"> <li>Vehicle speed: More than 20 km/h (12 MPH)</li> </ul>		Almost the same speed as the tachometer indication
VEHICLE SPEED	<ul style="list-style-type: none"> <li>Turn drive wheels and compare CONSULT-III value with the speedometer indication.</li> </ul>		Almost the same speed as the speedometer indication
IDL A/V LEARN	<ul style="list-style-type: none"> <li>Engine: Running</li> </ul>	Idle air volume learning has not been performed yet.	YET
		Idle air volume learning has already been performed successfully.	CMPLT
ENG OIL TEMP	<ul style="list-style-type: none"> <li>Engine: After warming up</li> </ul>		More than 70°C (158°F)
TRVL AFTER MIL	<ul style="list-style-type: none"> <li>Ignition switch: ON</li> </ul>	Vehicle has traveled after MIL has illuminated.	0 - 65,535 km (0 - 40,723 miles)
A/F S1 HTR (B1)	<ul style="list-style-type: none"> <li>Engine: After warming up, idle the engine (More than 140 seconds after starting engine)</li> </ul>		4 - 100%
A/F S1 HTR (B2)	<ul style="list-style-type: none"> <li>Engine: After warming up, idle the engine (More than 140 seconds after starting engine)</li> </ul>		4 - 100%
AC PRESS SEN	<ul style="list-style-type: none"> <li>Engine: Idle</li> <li>Both A/C switch and blower fan switch: ON (Compressor operates)</li> </ul>		1.0 - 4.0 V
VHCL SPEED SE	<ul style="list-style-type: none"> <li>Turn drive wheels and compare CONSULT-III value with the speedometer indication.</li> </ul>		Almost the same speed as the speedometer indication
SET VHCL SPD	<ul style="list-style-type: none"> <li>Engine: Running</li> </ul>	ASCD: Operating	The preset vehicle speed is displayed
MAIN SW	<ul style="list-style-type: none"> <li>Ignition switch: ON</li> </ul>	MAIN switch: Pressed	ON
		MAIN switch: Released	OFF
CANCEL SW	<ul style="list-style-type: none"> <li>Ignition switch: ON</li> </ul>	CANCEL switch: Pressed	ON
		CANCEL switch: Released	OFF
RESUME/ACC SW	<ul style="list-style-type: none"> <li>Ignition switch: ON</li> </ul>	RESUME/ACCELERATE switch: Pressed	ON
		RESUME/ACCELERATE switch: Released	OFF
SET SW	<ul style="list-style-type: none"> <li>Ignition switch: ON</li> </ul>	SET/COAST switch: Pressed	ON
		SET/COAST switch: Released	OFF
BRAKE SW1 (ASCD brake switch)	<ul style="list-style-type: none"> <li>Ignition switch: ON</li> </ul>	Brake pedal: Fully released	ON
		Brake pedal: Slightly depressed	OFF
BRAKE SW2 (Stop lamp switch)	<ul style="list-style-type: none"> <li>Ignition switch: ON</li> </ul>	Brake pedal: Fully released	OFF
		Brake pedal: Slightly depressed	ON
VHCL SPD CUT	<ul style="list-style-type: none"> <li>Ignition switch: ON</li> </ul>		NON
LO SPEED CUT	<ul style="list-style-type: none"> <li>Ignition switch: ON</li> </ul>		NON
AT OD MONITOR	<ul style="list-style-type: none"> <li>Ignition switch: ON</li> </ul>		OFF
AT OD CANCEL	<ul style="list-style-type: none"> <li>Ignition switch: ON</li> </ul>		OFF
CRUISE LAMP	<ul style="list-style-type: none"> <li>Ignition switch: ON</li> </ul>	MAIN switch: Pressed at the 1st time → at the 2nd time	ON → OFF
SET LAMP	<ul style="list-style-type: none"> <li>MAIN switch: ON</li> <li>When vehicle speed is between 40 km/h (25 MPH) and 144 km/h (89 MPH)</li> </ul>	ASCD: Operating	ON
		ASCD: Not operating	OFF

# ECM

## < ECU DIAGNOSIS INFORMATION >

[WITHOUT 7 INCH DISPLAY]

Monitor Item	Condition	Values/Status
ALT DUTY	• Engine: Idle	0 - 80%
A/F ADJ-B1	• Engine: Running	-0.330 - 0.330
A/F ADJ-B2	• Engine: Running	-0.330 - 0.330
BAT CUR SEN	• Engine speed: Idle • Battery: Fully charged*2 • Selector lever: P or N position • Air conditioner switch: OFF • No load	Approx. 2,600 - 3,500 mV
ALT DUTY SIG	• Power generation voltage variable control: Operating	ON
	• Power generation voltage variable control: Not operating	OFF
HO2 S2 DIAG1 (B1)	DTC P0139 self-diagnosis (delayed response) is incomplete.	INCMPT
	DTC P0139 self-diagnosis (delayed response) is complete.	CMPLT
HO2 S2 DIAG1 (B2)	DTC P0159 self-diagnosis (delayed response) is incomplete.	INCMPT
	DTC P0159 self-diagnosis (delayed response) is complete.	CMPLT
HO2 S2 DIAG2 (B1)	DTC P0139 self-diagnosis (slow response) is incomplete.	INCMPT
	DTC P0139 self-diagnosis (slow response) is complete.	CMPLT
HO2 S2 DIAG2 (B2)	DTC P0159 self-diagnosis (slow response) is incomplete.	INCMPT
	DTC P0159 self-diagnosis (slow response) is complete.	CMPLT

\*1: Accelerator pedal position sensor 2 signal and throttle position sensor 2 signal are converted by ECM internally. Thus, they differ from ECM terminals voltage signal.

\*2: Before measuring the terminal voltage, confirm that the battery is fully charged. Refer to [PG-3, "How to Handle Battery"](#).

### TERMINAL LAYOUT

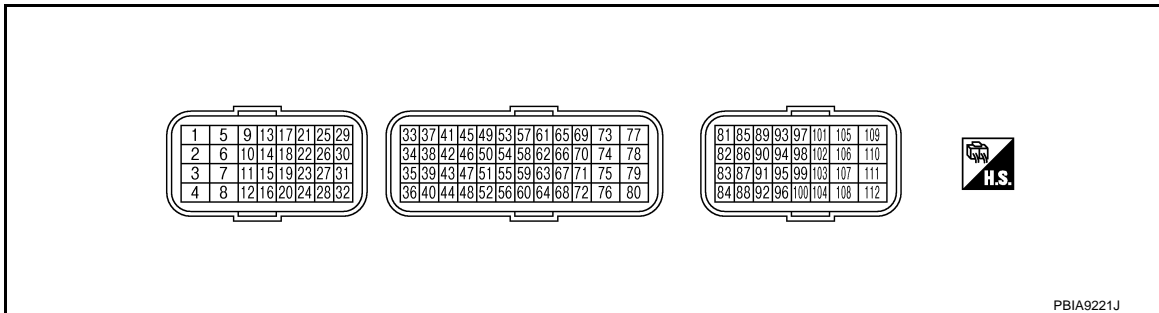

### PHYSICAL VALUES

**NOTE:**

- ECM is located in the engine room left side near battery.
- Specification data are reference values.
- Pulse signal is measured by CONSULT-III.

# ECM

< ECU DIAGNOSIS INFORMATION >

[WITHOUT 7 INCH DISPLAY]

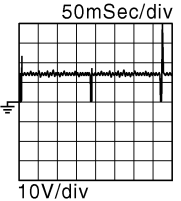
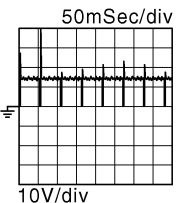
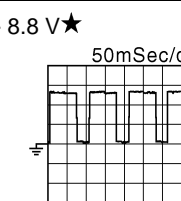
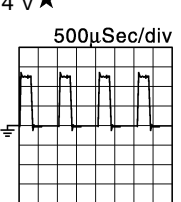
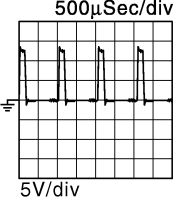
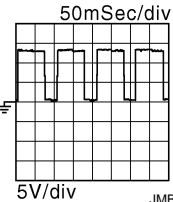
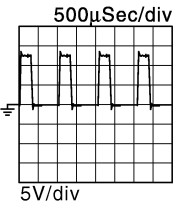
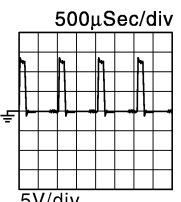
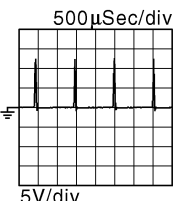
Terminal No.		Description		Condition	Value (Approx.)
+	-	Signal name	Input/Output		
1 (P/B)	112 (B)	Fuel injector No. 6	Output	[Engine is running] • Warm-up condition • Idle speed <b>NOTE:</b> The pulse cycle changes depending on rpm at idle	BATTERY VOLTAGE (11 - 14 V)★ 
3 (L/W)		Fuel injector No. 5			BATTERY VOLTAGE (11 - 14 V)★ 
29 (LG/R)		Fuel injector No. 4			BATTERY VOLTAGE (11 - 14 V)★ 
30 (R/Y)		Fuel injector No. 3			BATTERY VOLTAGE (11 - 14 V)★ 
31 (R/W)		Fuel injector No. 2			BATTERY VOLTAGE (11 - 14 V)★ 
32 (R/B)	Fuel injector No. 1				
2 (G/W)	112 (B)	Throttle control motor power supply	Input	[Ignition switch: ON]	BATTERY VOLTAGE (11 - 14 V)
4 (BR/Y)	112 (B)	A/F sensor 1 heater (bank 1)	Output	[Engine is running] • Warm-up condition • Idle speed (More than 140 seconds after starting engine)	2.9 - 8.8 V★ 
5 (L)	112 (B)	Throttle control motor (Open)	Output	[Ignition switch: ON] • Engine stopped • Selector lever: D position • Accelerator pedal: Fully depressed	0 - 14 V★ 
				[Ignition switch: ON] • Engine stopped • Selector lever: D position • Accelerator pedal: Fully released	0 - 14 V★ 
6 (P)	112 (B)	Throttle control motor (Close)	Output	[Ignition switch: ON] • Engine stopped • Selector lever: D position • Accelerator pedal: Fully released	0 - 14 V★ 

# ECM

< ECU DIAGNOSIS INFORMATION >

[WITHOUT 7 INCH DISPLAY]

Terminal No.		Description		Condition	Value (Approx.)
+	—	Signal name	Input/Output		
8 (SB)	112 (B)	A/F sensor 1 heater (bank 2)	Output	[Engine is running] • Warm-up condition • Idle speed (More than 140 seconds after starting engine)	2.9 - 8.8 V★ 
9 (L/B) 10 (G/R) 11 (Y/R) 18 (GR/R) 19 (P) 21 (W)	112 (B)	Ignition signal No. 3 Ignition signal No. 2 Ignition signal No. 1 Ignition signal No. 6 Ignition signal No. 5 Ignition signal No. 4	Output	[Engine is running] • Warm-up condition • Idle speed <b>NOTE:</b> The pulse cycle changes depending on rpm at idle	0 - 0.2 V★ 
				[Engine is running] • Warm-up condition • Engine speed: 2,000 rpm	0.1 - 0.4 V★ 
12 (B)	—	ECM ground	—	—	—
13 (P/B)	112 (B)	Heated oxygen sensor 2 heater (bank 1)	Output	[Engine is running] • Engine speed: Below 3,600 rpm after the following conditions are met - Engine: after warming up - Keeping the engine speed between 3,500 and 4,000 rpm for 1 minute and at idle for 1 minute under no load	10 V★ 
				[Ignition switch: ON] • Engine stopped [Engine is running] • Engine speed: Above 3,600 rpm	BATTERY VOLTAGE (11 - 14 V)
14 (GR)	112 (B)	Fuel pump relay	Output	[Ignition switch: ON] • For 1 second after turning ignition switch ON [Engine is running]	0 - 1.5 V
				[Ignition switch: ON] • More than 1 second after turning ignition switch ON	BATTERY VOLTAGE (11 - 14 V)
15 (O)	112 (B)	Throttle control motor relay	Output	[Ignition switch: ON → OFF]	0 - 1.0 V → BATTERY VOLTAGE (11 - 14 V) → 0 V
				[Ignition switch: ON]	0 - 1.0 V
16 (B/Y)	—	ECM ground	—	—	—

A  
B  
C  
D  
E  
F  
G  
H  
HAC

J  
K  
L  
M  
N  
O  
P

# ECM

< ECU DIAGNOSIS INFORMATION >

[WITHOUT 7 INCH DISPLAY]

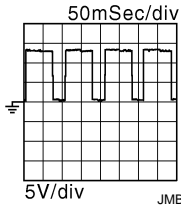
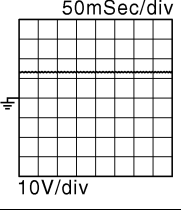
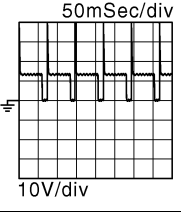
Terminal No.		Description		Condition	Value (Approx.)
+	-	Signal name	Input/Output		
17 (R)	112 (B)	Heated oxygen sensor 2 heater (bank 2)	Output	[Engine is running] • Engine speed: Below 3,600 rpm after the following conditions are met - Engine: after warming up - Keeping the engine speed between 3,500 and 4,000 rpm for 1 minute and at idle for 1 minute under no load	10 V★ 
				[Ignition switch: ON] • Engine stopped [Engine is running] • Engine speed: Above 3,600 rpm	BATTERY VOLTAGE (11 - 14 V)
24 (W/B)	112 (B)	ECM relay (Self shut-off)	Output	[Engine is running] [Ignition switch: OFF] • A few seconds after turning ignition switch OFF	0 - 1.5 V
				[Ignition switch: OFF] • More than a few seconds after turning ignition switch OFF	BATTERY VOLTAGE (11 - 14 V)
25 (P/L)	112 (B)	EVAP canister purge volume control solenoid valve	Output	[Engine is running] • Idle speed • Accelerator pedal: Not depressed even slightly, after engine starting	BATTERY VOLTAGE (11 - 14 V)★ 
				[Engine is running] • Engine speed: approximately 2,000 rpm (More than 100 seconds after starting engine)	BATTERY VOLTAGE (11 - 14 V)★ 
26 (GR/B)	112 (B)	VIAS control solenoid valve 2	Output	[Engine is running] • Warm-up condition • Idle speed	BATTERY VOLTAGE (11 - 14 V)
				[Engine is running] • Warm-up condition • When revving engine up to 5,000 rpm quickly	BATTERY VOLTAGE (11 - 14 V) ↓ 0 - 1.0 V ↓ BATTERY VOLTAGE (11 - 14 V)
27 (V)	112 (B)	VIAS control solenoid valve 1	Output	[Engine is running] • Warm-up condition • Idle speed	BATTERY VOLTAGE (11 - 14 V)
				[Engine is running] • Warm-up condition • When revving engine up to 5,000 rpm quickly	BATTERY VOLTAGE (11 - 14 V) ↓ 0 - 1.0 V ↓ BATTERY VOLTAGE (11 - 14 V)

# ECM

< ECU DIAGNOSIS INFORMATION >

[WITHOUT 7 INCH DISPLAY]

Terminal No.		Description		Condition	Value (Approx.)	
+	—	Signal name	Input/Output			
28 (BR/W)	112 (B)	Electronic controlled engine mount control solenoid valve	Output	[Engine is running] • Idle speed	0 - 1.0 V	A
				[Engine is running] • Engine speed: More than 950 rpm	BATTERY VOLTAGE (11 - 14 V)	B
33 (W)	112 (B)	Heated oxygen sensor 2 (bank 1)	Input	[Engine is running] • Revving engine from idle to 3,000 rpm quickly after the following conditions are met - Engine: after warming up - Keeping the engine speed between 3,500 and 4,000 rpm for 1 minute and at idle for 1 minute under no load	0 - 1.0 V	C
						D
34 (W/L)	112 (B)	Heated oxygen sensor 2 (bank 2)	Input	[Engine is running] • Revving engine from idle to 3,000 rpm quickly after the following conditions are met - Engine: after warming up - Keeping the engine speed between 3,500 and 4,000 rpm for 1 minute and at idle for 1 minute under no load	0 - 1.0 V	E
						F
35 (B)	—	Sensor ground (Heated oxygen sensor 2)	—	—	—	G
36 (B)	—	Sensor ground (Throttle position sensor)	—	—	—	H
37 (W)	112 (B)	Throttle position sensor 1	Input	[Ignition switch: ON] • Engine stopped • Selector lever: D position • Accelerator pedal: Fully released	More than 0.36 V	HAC
				[Ignition switch: ON] • Engine stopped • Selector lever: D position • Accelerator pedal: Fully depressed	Less than 4.75 V	J
38 (R)	112 (B)	Throttle position sensor 2	Input	[Ignition switch: ON] • Engine stopped • Selector lever: D position • Accelerator pedal: Fully released	Less than 4.75 V	K
				[Ignition switch: ON] • Engine stopped • Selector lever: D position • Accelerator pedal: Fully depressed	More than 0.36 V	L
39 (R)	40 (G)	Refrigerant pressure sensor	Input	[Engine is running] • Warm-up condition • Both A/C switch and blower fan motor switch: ON (Compressor operates)	1.0 - 4.0 V	M
						N
40 (G)	—	Sensor ground (Refrigerant pressure sensor)	—	—	—	O
						P

# ECM

< ECU DIAGNOSIS INFORMATION >

[WITHOUT 7 INCH DISPLAY]

Terminal No.		Description		Condition	Value (Approx.)
+	—	Signal name	Input/ Output		
41 (O/B)	48 (B/P)	Power steering pressure sensor	Output	[Engine is running] • Steering wheel: Being turned	0.5 - 4.5 V
				[Engine is running] • Steering wheel: Not being turned	0.4 - 0.8 V
42 (BR)	44 (G/B)	Battery current sensor	Input	[Engine is running] • Battery: Fully charged*2 • Idle speed	2.6 - 3.5 V
44 (G/B)	—	Sensor ground (Battery current sensor)	—	—	—
45 (P)	49 (L)	A/F sensor 1 (bank 1)	Input	[Ignition switch: ON]	2.2 V
46 (Y)	52 (B/R)	Engine coolant temperature sensor	Input	[Engine is running]	0 - 4.8 V Output voltage varies with engine coolant temperature.
47 (G)	36 (B)	Sensor power supply (Throttle position sensor)	—	[Ignition switch: ON]	5 V
48 (B/P)	—	Sensor ground (Power steering pressure sensor)	—	—	—
49 (L)	112 (B)	A/F sensor 1 (bank 1)	Input	[Engine is running] • Warm-up condition • Engine speed: 2,000 rpm	1.8 V Output voltage varies with air fuel ratio.
50 (L/Y)	56 (G/B)	Intake air temperature sensor	Input	[Engine is running]	0 - 4.8 V Output voltage varies with intake air temperature.
51 (R/Y)	44 (G/B)	Sensor power supply (Battery current sensor)	—	[Ignition switch: ON]	5 V
52 (B/R)	—	Sensor ground (Engine coolant temperature sensor/Engine oil temperature sensor)	—	—	—
53 (V)	57 (LG)	A/F sensor 1 (bank 2)	Input	[Ignition switch: ON]	2.2 V
54 (G)	52 (B/R)	Engine oil temperature sensor	Input	[Engine is running]	0 - 4.8 V Output voltage varies with engine oil temperature.
55 (SB)	48 (Y)	Sensor power supply (Power steering pressure sensor)	—	[Ignition switch: ON]	5 V
56 (G/B)	—	Sensor ground (Mass air flow sensor/Intake air temperature sensor)	—	—	—
57 (LG)	112 (B)	A/F sensor 1 (bank 2)	Input	[Engine is running] • Warm-up condition • Engine speed: 2,000 rpm	1.8 V Output voltage varies with air fuel ratio.
58 (O)	56 (G/B)	Mass air flow sensor	Input	[Engine is running] • Warm-up condition • Idle speed	0.9 - 1.2 V
				[Engine is running] • Warm-up condition • Engine speed: 2,500 rpm	1.6 - 1.9 V



# ECM

< ECU DIAGNOSIS INFORMATION >

[WITHOUT 7 INCH DISPLAY]

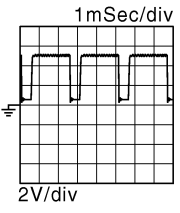
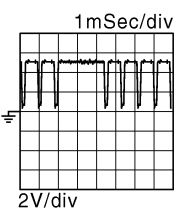
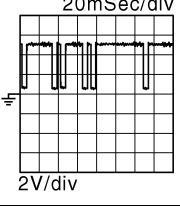
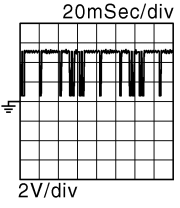
Terminal No.		Description		Condition	Value (Approx.)
+	—	Signal name	Input/Output		
59 (G/W)	64 (B/R)	Sensor power supply [Camshaft position sensor (PHASE) (bank 1)]	—	[Ignition switch: ON]	5 V
60 (Y/B)	—	Sensor ground [Crankshaft position sensor (POS)]	—	—	—
61 (B)	67 (—)	Knock sensor (bank 1)	Input	[Engine is running] • Idle speed	2.5 V*1
62 (W)	67 (—)	Knock sensor (bank 2)	Input	[Engine is running] • Idle speed	2.5 V*1
63 (R/W)	68 (Y/G)	Sensor power supply [Camshaft position sensor (PHASE) (bank 2)]	—	[Ignition switch: ON]	5 V
64 (B/R)	—	Sensor ground [Camshaft position sensor (PHASE) (bank 1)]	—	—	—
65 (W/B)	60 (Y/B)	Crankshaft position sensor (POS)	Input	[Engine is running] • Warm-up condition • Idle speed <b>NOTE:</b> The pulse cycle changes depending on rpm at idle	4.0 - 5.0 V★ 
				[Engine is running] • Engine speed: 2,000 rpm	4.0 - 5.0 V★ 
67 (—)	—	Sensor ground (Knock sensor)	—	—	—
68 (Y/G)	—	Sensor ground [Camshaft position sensor (PHASE) (bank 2)]	—	—	—
69 (BR/W)	68 (Y/G)	Camshaft position sensor (PHASE) (bank 2)	Input	[Engine is running] • Warm-up condition • Idle speed <b>NOTE:</b> The pulse cycle changes depending on rpm at idle	3.0 - 5.0 V★ 
				[Engine is running] • Engine speed is 2,000 rpm	3.0 - 5.0 V★ 

A

B

C

D

E

F

G

H

HAC

J

K

L

M

N

O

P

# ECM

< ECU DIAGNOSIS INFORMATION >

[WITHOUT 7 INCH DISPLAY]

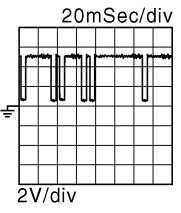
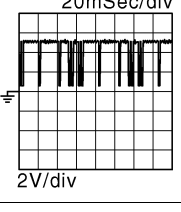
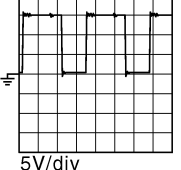
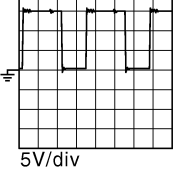
Terminal No.		Description		Condition	Value (Approx.)
+	-	Signal name	Input/Output		
70 (W/R)	64 (B/R)	Camshaft position sensor (PHASE) (bank 1)	Input	[Engine is running] • Warm-up condition • Idle speed <b>NOTE:</b> The pulse cycle changes depending on rpm at idle	3.0 - 5.0 V★  JMBIA0045GB
				[Engine is running] • Engine speed is 2,000 rpm	3.0 - 5.0 V★  JMBIA0046GB
72 (BR/W)	40 (G)	Sensor power supply (Refrigerant pressure sensor)	—	[Ignition switch: ON]	5 V
75 (Y)	112 (B)	Intake valve timing control solenoid valve (bank 2)	Output	[Engine is running] • Warm-up condition • Idle speed	BATTERY VOLTAGE (11 - 14 V)
				[Engine is running] • Warm-up condition • Engine speed: 2,000 rpm	7 - 12 V★  JMBIA0038GB
76 (R/G)	60 (Y/B)	Sensor power supply [Crankshaft position sensor (POS)]	—	[Ignition switch: ON]	5 V
77 (W/L)	112 (B)	Power supply for ECM (Back-up)	Input	[Ignition switch: OFF]	BATTERY VOLTAGE (11 - 14 V)
78 (R/L)	112 (B)	Intake valve timing control solenoid valve (bank 1)	Output	[Engine is running] • Warm-up condition • Idle speed	BATTERY VOLTAGE (11 - 14 V)
				[Engine is running] • Warm-up condition • Engine speed: 2,000 rpm	7 - 12 V★  JMBIA0038GB
81 (W)	84 (B)	Accelerator pedal position sensor 1	Input	[Ignition switch: ON] • Engine stopped • Accelerator pedal: Fully released	0.5 - 1.0 V
				[Ignition switch: ON] • Engine stopped • Accelerator pedal: Fully depressed	4.2 - 4.8 V

# ECM

< ECU DIAGNOSIS INFORMATION >

[WITHOUT 7 INCH DISPLAY]

Terminal No.		Description		Condition	Value (Approx.)	
+	—	Signal name	Input/Output			
82 (O)	100 (G)	Accelerator pedal position sensor 2	Input	[Ignition switch: ON] • Engine stopped • Accelerator pedal: Fully released	0.25 - 0.50 V	A
				[Ignition switch: ON] • Engine stopped • Accelerator pedal: Fully depressed	2.0 - 2.5 V	B
83 (BR)	84 (B)	Sensor power supply (Accelerator pedal position sensor 1)	—	[Ignition switch: ON]	5 V	C
84 (B)	—	Sensor ground (Accelerator pedal position sensor 1)	—	—	—	D
85 (Y)	92 (BR)	ASCDC steering switch	Input	[Ignition switch: ON] • ASCDC steering switch: OFF	4 V	E
				[Ignition switch: ON] • MAIN switch: Pressed	0 V	F
				[Ignition switch: ON] • CANCEL switch: Pressed	1 V	G
				[Ignition switch: ON] • RESUME/ACCELERATE switch: Pressed	3 V	H
				[Ignition switch: ON] • SET/COAST switch: Pressed	2 V	HAC
86 (SB)	96 (GR)	EVAP control system pressure sensor	Input	[Ignition switch: ON]	1.8 - 4.8 V	I
87 (GR)	100 (G)	Sensor power supply (Accelerator pedal position sensor 2)	—	[Ignition switch: ON]	5 V	J
88 (O)	—	Data link connector	Input/Output	—	—	K
91 (L)	96 (GR)	Sensor power supply (EVAP control system pressure sensor)	—	[Ignition switch: ON]	5 V	L
92 (BR)	—	Sensor ground (ASCDC steering switch)	—	—	—	M
93 (BR)	112 (B)	Ignition switch	Input	[Ignition switch: OFF]	0 V	N
				[Ignition switch: ON]	BATTERY VOLTAGE (11 - 14 V)	O

# ECM

< ECU DIAGNOSIS INFORMATION >

[WITHOUT 7 INCH DISPLAY]

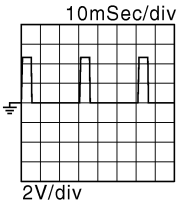
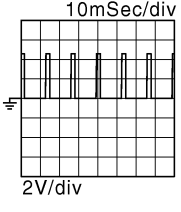
Terminal No.		Description		Condition	Value (Approx.)
+	—	Signal name	Input/Output		
94 (GR)	112 (B)	Engine speed output signal	Output	[Engine is running] • Warm-up condition • Idle speed <b>NOTE:</b> The pulse cycle changes depending on rpm at idle	1 V★ 
				[Engine is running] • Engine speed: 2,000 rpm	1 V★ 
95 (Y)	104 (SB)	Fuel tank temperature sensor	Input	[Engine is running]	0 - 4.8 V Output voltage varies with fuel tank temperature.
96 (GR)	—	Sensor ground (EVAP control system pressure sensor)	—	—	—
97 (P)	—	CAN communication line	Input/Output	—	—
98 (L)	—	CAN communication line	Input/Output	—	—
100 (G)	—	Sensor ground (Accelerator pedal position sensor 2)	—	—	—
102 (R)	112 (B)	PNP signal	Input	[Ignition switch: ON] • Selector lever: P or N position	BATTERY VOLTAGE (11 - 14 V)
				[Ignition switch: ON] • Selector lever: Except above position	0 V
104 (SB)	—	Sensor ground (Fuel tank temperature sensor)	—	—	—
105 (V)	112 (B)	Power supply for ECM	Input	[Ignition switch: ON]	BATTERY VOLTAGE (11 - 14 V)
106 (SB)	112 (B)	Stop lamp switch	Input	[Ignition switch: OFF] • Brake pedal: Fully released	0 V
				[Ignition switch: OFF] • Brake pedal: Slightly depressed	BATTERY VOLTAGE (11 - 14 V)
107 (B) 108 (B)	—	ECM ground	—	—	—
109 (W)	112 (B)	EVAP canister vent control valve	Output	[Ignition switch: ON]	BATTERY VOLTAGE (11 - 14 V)

# ECM

< ECU DIAGNOSIS INFORMATION >

[WITHOUT 7 INCH DISPLAY]

Terminal No.		Description		Condition	Value (Approx.)
+	—	Signal name	Input/Output		
110 (G)	112 (B)	ASCD brake switch	Input	[Ignition switch: ON] • Brake pedal: Slightly depressed	0 V
				[Ignition switch: ON] • Brake pedal: Fully released	BATTERY VOLTAGE (11 - 14 V)
111 (B) 112 (B)	—	ECM ground	—	—	—

★: Average voltage for pulse signal (Actual pulse signal can be confirmed by oscilloscope.)

\*1: This may vary depending on internal resistance of the tester.

\*2: Before measuring the terminal voltage, confirm that the battery is fully charged. Refer to [PG-3, "How to Handle Battery"](#).

A  
B  
C  
D  
E  
F  
G  
H  
J  
K  
L  
M  
N  
O  
P

HAC

# A/C AUTO AMP.

< ECU DIAGNOSIS INFORMATION >

[WITHOUT 7 INCH DISPLAY]

## A/C AUTO AMP.

### Reference Value

INFOID:000000005514647

### VALUES ON THE DIAGNOSIS TOOL

#### CONSULT-III MONITOR ITEM

Monitor item	Condition		Value/Status
COMP REQ SIG	Engine: Run at idle after warming up	A/C switch: ON (Compressor operation status)	On
		A/C switch: OFF	Off
FAN REQ SIG	Engine: Run at idle after warming up	Blower fan: ON	On
		Blower fan: OFF	Off
AMB TEMP SEN	Ignition switch ON	—	22 - 131°F (-30 - 55°C)
IN-VEH TEMP	Ignition switch ON	—	22 - 131°F (-30 - 55°C)
INT TEMP SEN	Ignition switch ON	—	22 - 131°F (-30 - 55°C)
SUNLOAD SEN	Ignition switch ON	—	0 - 1045 w/m <sup>2</sup> (0 - 900 kcal/m <sup>2</sup> ·h)
AMB SEN CAL	Ignition switch ON	—	22 - 131°F (-30 - 55°C)
IN-VEH CAL	Ignition switch ON	—	22 - 131°F (-30 - 55°C)
INT TEMP CAL	Ignition switch ON	—	22 - 131°F (-30 - 55°C)
SUNL SEN CAL	Ignition switch ON	—	0 - 1045 w/m <sup>2</sup> (0 - 900 kcal/m <sup>2</sup> ·h)
FAN DUTY	Engine: Run at idle after warming up	Blower fan: ON	25 - 81
		Blower fan: OFF	0
XM	Ignition switch ON	—	-100 - 155
ENG COOL TEMP	Ignition switch ON	—	Values according to coolant temperature
VEHICLE SPEED	Driving	—	Equivalent to speedometer reading

### TERMINAL LAYOUT

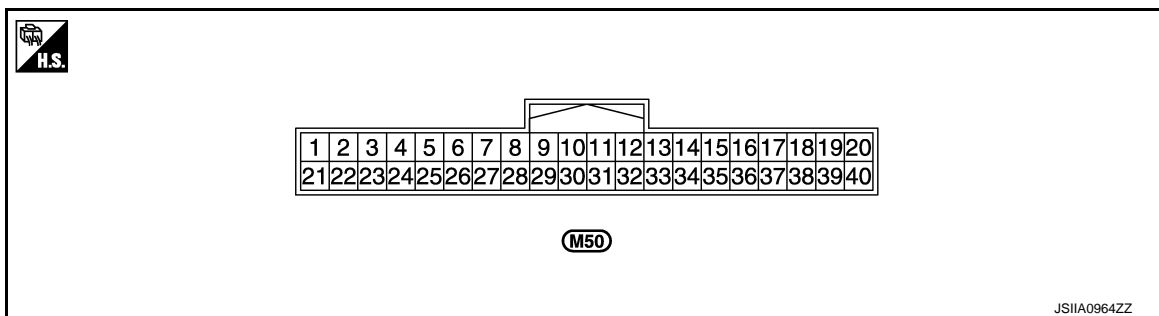

### PHYSICAL VALUES

# A/C AUTO AMP.

< ECU DIAGNOSIS INFORMATION >

[WITHOUT 7 INCH DISPLAY]

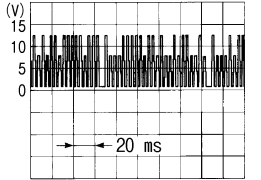
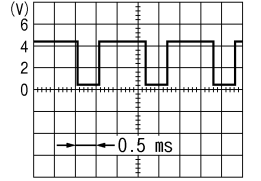
Terminal No. (Wire color)		Description		Condition	Value (Approx.)
+	-	Signal name	Input/ Output		
6 (L)	Ground	TX (AMP > SW-DISP)	Input	—	—
7 (P)	Ground	RX (SW > AMP)	Output	—	—
10 (L)	Ground	LAN signal	Input/ Output	—	 <p style="text-align: right; font-size: small;">SJIA1453J</p>
11 (R)	Ground	Power supply for each door motor	Input	Ignition switch ON	Battery voltage
15 (O)	Ground	Sunload sensor	Input	—	—
16 (G)	Ground	Intake sensor	Input	—	—
17 (R)	Ground	Power supply from ACC	—	Ignition switch ACC	Battery voltage
19 (B)	Ground	Ground	—	Ignition switch ON	0 V
20 (G)	Ground	Power supply from IGN	—	Ignition switch ON	Battery voltage
32 (L)	Ground	Blower motor control signal	Output	<ul style="list-style-type: none"> <li>• Ignition switch ON</li> <li>• Blower speed: 1st speed (manual)</li> </ul>	 <p style="text-align: right; font-size: small;">JSIIA0096ZZ</p>
34 (P)	Ground	Power supply for ambient meter	Output	Ignition switch ON	5V
35 (L)	Ground	Ambient sensor	Input	—	—
36 (LG)	Ground	In-vehicle sensor	Input	—	—
37 (Y)	Ground	Sensor ground	—	Ignition switch ON	0 V
39 (B)	Ground	Ground	—	Ignition switch ON	0 V
40 (Y)	Ground	Power supply from BATT	—	Ignition switch OFF	Battery voltage

A  
B  
C  
D  
E  
F  
G  
H  
HAC  
J  
K  
L  
M  
N  
O  
P





# A/C AUTO AMP.

< ECU DIAGNOSIS INFORMATION >

[WITHOUT 7 INCH DISPLAY]

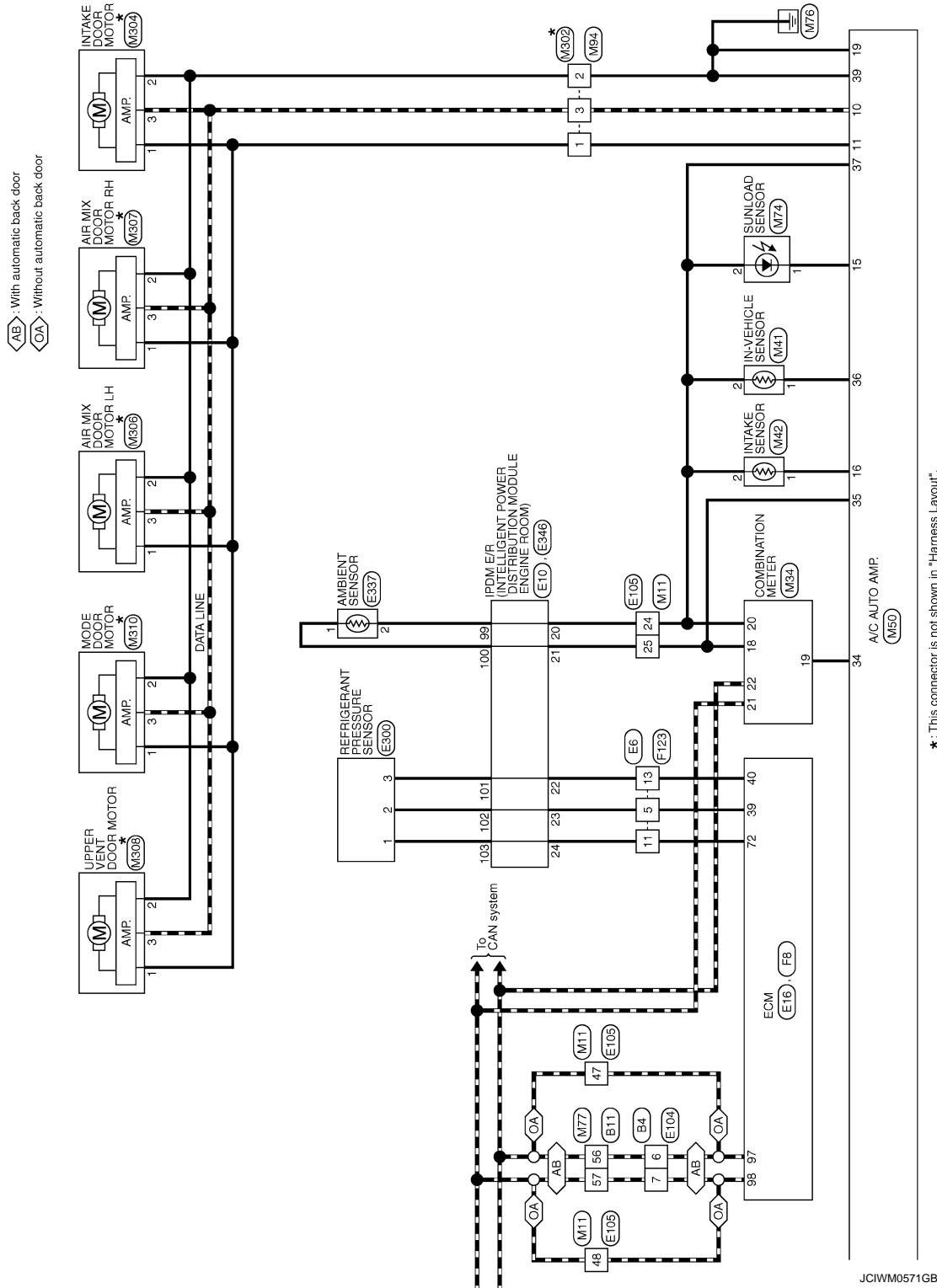

\*: This connector is not shown in "Harness Layout".

JCIWM0571GB

A  
B  
C  
D  
E  
F  
G  
H  
I  
J  
K  
L  
M  
N  
O  
P

HAC

AUTOMATIC AIR CONDITIONING SYSTEM

Connector No.	B4
Connector Name	WIRE TO WIRE
Connector Type	HS16MW-CS



1	2	3	4	5	6	7		
8	9	10	11	12	13	14	15	16

Terminal No.	Color of Wire	Signal Name [Specification]
1	SB	-
2	W	-
3	W	-
4	R	-
5	O	-
6	P	-
7	L	-
8	B	-
9	LG	-
10	Y	-
11	L	-
12	BR	-
13	P	-
14	BR	-
15	O	-
16	G	-

Connector No.	B11
Connector Name	WIRE TO WIRE
Connector Type	HS80MW-CS19



Terminal No.	Color of Wire	Signal Name [Specification]
1	SHIELD	-
2	B	-
3	R/L	-
4	R/W	-
5	SB	-
6	P	-

7	V	-
8	SHIELD	-
9	BP/L	-
10	V/G	-
11	V/L	-
12	W/L	-
13	L	-
14	BR	-
15	SB	-
16	BR	-
17	V	-
18	SB	-
19	R	-
20	P	-
21	LG	-
22	W	-
23	Y	-
24	GR	-
25	Y	-
27	V	-
28	W/L	-
30	P	-
31	O	-
32	BR	-
34	SB	-
35	SHIELD	-
36	L/O	-
37	LG	-
40	Y	-
41	O	-
42	SB	-
43	G	-
44	BR	-
45	L	-
46	GR	-
47	V	-
48	GR	- [With rear view camera and telephone]
48	BR	- [With rear view camera without telephone]
49	Y	-
50	SHIELD	-
51	B	-
52	B	-
53	Y	-
54	LG	-
55	BR	-
56	P	-
57	L	-
58	R	-
59	SHIELD	-
60	B	-
61	R/L	-
62	R/W	-

1	L	-
3	Y	-
4	R	-
5	GR	-
6	V	-
8	P	-
10	W	-
11	G	-
12	BR	-
13	SB	-
14	B	-
15	O	-

Connector No.	E7
Connector Name	WIRE TO WIRE
Connector Type	HS10MW-CS



1	2	3	4		
5	6	7	8	9	10

Terminal No.	Color of Wire	Signal Name [Specification]
1	B	-
2	L	-
5	R	-
6	B	-
7	O	-
10	B	-

63	LG	-
64	Y	-
66	GR	-
67	G	-
68	R	-
69	SHIELD	-
70	W/R	-
71	B/R	-
72	Y	-
73	LG	-
74	SB	-
75	L	-
76	G	-
77	R	-
78	SHIELD	-
79	B	-
80	W	-
81	R	-
82	L	-
83	BR	-
84	O	-
85	G	-
86	SB	-
87	R	-
88	G	-
89	GR	-
90	Y	-
91	G	-
92	BR	-
93	G	-
94	V	-
95	BR	-
96	GR	-
97	R	-
98	LG	-
99	O	-

Connector No.	E6
Connector Name	WIRE TO WIRE
Connector Type	TK16MGY-IV



1	2	3	4	5	6	7		
8	9	10	11	12	13	14	15	16

Terminal No.	Color of Wire	Signal Name [Specification]
--------------	---------------	-----------------------------

**AUTOMATIC AIR CONDITIONING SYSTEM**

Connector No.	E10
Connector Name	SMILE INTELLIGENT POWER DISTRIBUTION MODULE ENGINE ROOM
Connector Type	TH20PW-CS12-M4-TV

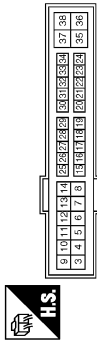

Connector No.	E11
Connector Name	SMILE INTELLIGENT POWER DISTRIBUTION MODULE ENGINE ROOM
Connector Type	TH20PW-MH



97	P	VEHCAN-L
98	L	VEHCAN-H
100	G	GND-A-APSZ
102	R	NEUT-H
104	SB	GND-TF
105	V	VBR
106	SB	BRAKE
107	B	GND
108	B	GND
109	W	ODCV
110	G	BNCSW
111	B	GND
112	B	GND

Connector No.	E104
Connector Name	WIRE TO WIRE
Connector Type	NS16FW-CS



Terminal No.	Color of Wire	Signal Name [Specification]
4	LG	-
5	Y	-
7	GR	-
10	BR	-
11	P	-
12	B	-
13	SB	-
15	W	-
16	L/Y	-
19	Y	-
20	L	-
21	O	-
22	SB	-
23	GR	-
24	G	-
25	GR	-
26	Y	-
27	W	-
28	SB	-
30	BR	-
32	V	-
33	G	-
34	O	-
35	P	-
36	G	-
38	GR	-

Terminal No.	Color of Wire	Signal Name [Specification]
39	P	-
40	L	-
41	B	-
42	SB	-
43	Y	-
44	W	-
45	O	-
46	BR	-

Connector No.	E16
Connector Name	ECM
Connector Type	RH24FE-RZ8-L-LH

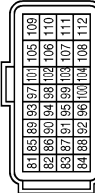

Terminal No.	Color of Wire	Signal Name [Specification]
81	W	APSI
82	O	APSZ
83	BR	AVCOI-APSI
84	B	GND-APSI
85	Y	ASCD SW
86	SB	FTPRES
87	GR	AVCCZ-APSZ
88	O	KLINE
91	L	AVCCZ-FTPRES
92	BR	GND-ASQDSW
93	BR	IGN SW
94	GR	TACHO(CABIN)
95	Y	TF
96	GR	GND-FTPRES

Terminal No.	Color of Wire	Signal Name [Specification]
1	Y	-
2	SB	-
3	L	-
4	R	-
5	L	-
6	P	-
7	L	-
8	B/W	-
9	SB	-
10	GR	-
11	R	-
12	W	-
13	P	-
14	V	-
15	Y	-
16	L	-

A  
B  
C  
D  
E  
F  
G  
H  
HAC  
J  
K  
L  
M  
N  
O  
P

AUTOMATIC AIR CONDITIONING SYSTEM

Connector No.	E105
Connector Name	WIRE TO WIRE
Connector Type	TH70MW-CS10-M3

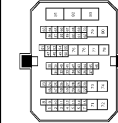

Terminal No.	Color of Wire	Signal Name [Specification]
2	BR	-
3	Y	-
4	W	-
5	LG	-
6	GR	-
8	G	-
11	P	-
12	L	-
13	Y	-
14	O	-
15	BR	-
20	Y	-
21	BR	-
22	P	-
23	P	-
24	L	-
25	O	-
26	G	-
27	V	-
28	SB	-
29	W	-
30	Y	-
43	P	-
46	L	-
49	SB	-
50	GR	-
51	LG	-
52	V	-
53	GR	-
54	BR	-
55	Y	-
56	W/L	-
60	V	-
61	BR	-
62	O	-
63	L/O	-
64	SHIELD	-
66	W	-

67	BR	-
68	Y	-
69	SB	-
70	GR	-
71	SB	-
72	Y	-
73	L	-
74	W	-
75	BR	-
76	GR	-
77	O	-
78	V	-
79	Y	-
80	R	-
81	W	-
82	LG	-
83	O	-

Connector No.	E300
Connector Name	REFRIGERANT PRESSURE SENSOR
Connector Type	RK03FB



Terminal No.	Color of Wire	Signal Name [Specification]
1	P	-
2	B	-
3	L	-

Connector No.	E337
Connector Name	AMBIENT SENSOR
Connector Type	RS02FB



Terminal No.	Color of Wire	Signal Name [Specification]
1	P	-
2	B	-
3	L	-

1	SB	-
2	BR	-

Connector No.	E336
Connector Name	SPRINKLER INTELLIGENT POWER DISTRIBUTION MODULE (SPRINKLER)
Connector Type	TH18FW-NH



Terminal No.	Color of Wire	Signal Name [Specification]
91	R	-
92	LG	-
93	BR	-
100	SB	-
101	L	-
102	B	-
103	P	-

Connector No.	F8
Connector Name	ECM
Connector Type	RH40FBR-R28-L-LH

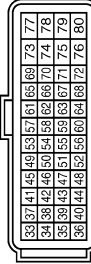

Terminal No.	Color of Wire	Signal Name [Specification]
33	W	-
34	W/L	OZSR1
35	B	OZSR2
36	B	GND-OZSR1,OZSR2
37	W	GND-TPS-BI
38	R	TPS2-BI
39	R	PDPRES
40	G	GND-PDPRES
41	O/B	PSPRES
42	BR	CURSEM
44	G/B	GND-CURSINTP

45	P	AF-1
46	Y	TW
47	G	AVCCI-TPS-BI
48	B/P	GND-PSPRES
49	L	AF-1
50	L/Y	TAI
51	R/Y	AVCCI-CURSINTP
52	B/R	GND-TWTO1
53	V	AF-2
54	G	TO1
55	SB	AVCCI-PSPRES
56	G/B	GA-GND-TAI
57	LG	AF-2
58	O	OAI+
59	G/W	AVCCI-PHASE1EP1
60	Y/B	GND-POS
61	B	KKK1
62	W	KKK2
63	R/W	AVCCI-PHASE2EP2
64	B/R	GND-PHASE1EP1
65	W/B	POS
67	SHIELD	GND-KKK1,KKK2
68	Y/G	GND-PHASE2EP2
69	BR/W	PHASE2
70	W/R	PHASE1
72	BR/W	AVCC2-PDPRES
75	Y	CVTCH2
76	R/G	AVCC2-POS
77	W/L	BAIT
78	R/L	CVTCH1

AUTOMATIC AIR CONDITIONING SYSTEM

Connector No.	F12
Connector Name	SWAYLE INTELLIGENT POWER DISTRIBUTION MODULE FUSE BLOCK
Connector Type	TH20PW-CS12-M4

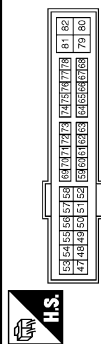

Connector No.	F121
Connector Name	WIRE TO WIRE
Connector Type	NS10PFW-CS



Connector No.	M1
Connector Name	FUSE BLOCK (J/B)
Connector Type	NS08FW-M2



Connector No.	M3
Connector Name	FUSE BLOCK (J/B)
Connector Type	NS12PFW-CS



Terminal No.	Color of Wire	Signal Name [Specification]
48	W	-
49	R/B	-
51	LG	-
52	Y/G	-
53	R/W	-
54	G/W	-
55	W/L	-
56	R/Y	-
57	O	-
58	Y	-
69	W/B	-
70	O	-
72	R/B	-
75	LG	-
76	SB	-
77	GR	-
80	B	-

Terminal No.	Color of Wire	Signal Name [Specification]
1	B/Y	-
2	R/Y	-
5	R/W	-
6	B	-
7	R/G	-
10	B	-

Connector No.	F123
Connector Name	WIRE TO WIRE
Connector Type	TK18FGY-1V



Connector No.	F18
Connector Name	COMPRESSOR
Connector Type	RH02FB



Terminal No.	Color of Wire	Signal Name [Specification]
1	W	-
2	B	-

Terminal No.	Color of Wire	Signal Name [Specification]
1A	Y	-
2A	G	-
3A	Y	-
4A	GR	-
5A	R	-
6A	W	-
7A	LG	-
8A	Y	-

Connector No.	M2
Connector Name	FUSE BLOCK (J/B)
Connector Type	NS10PFW-CS



Terminal No.	Color of Wire	Signal Name [Specification]
1B	W	-
3B	L	-
4B	G	-
5B	L	-
6B	Y	-
7B	R	-
8B	R	-
9B	GR	-

A  
B  
C  
D  
E  
F  
G  
H  
HAC  
J  
K  
L  
M  
N  
O  
P

AUTOMATIC AIR CONDITIONING SYSTEM

Connector No.	M11
Connector Name	WIRE TO WIRE
Connector Type	TH40PW-CS10-M3

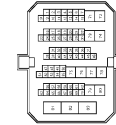

Terminal No.	Color of Wire	Signal Name [Specification]
2	L	-
3	P	-
4	O	-
5	O	-
6	G	-
8	R	-
11	P	-
12	L	-
13	V	-
14	Y	-
15	R	-
20	Y	-
21	BR	-
22	G	-
23	P	-
24	Y	-
25	L	-
26	L	-
27	O	-
28	BR	-
29	L	-
30	R	-
42	P	-
46	L	-
49	W	-
50	GR	-
51	LG	-
52	Y	-
53	V	-
54	SB	-
55	P	-
56	SB	-
60	V	-
61	GR	-
62	O	-
63	V	-
64	SHIELD	-
66	W	-

Connector No.	M16
Connector Name	A/C DISPLAY
Connector Type	TH10PE-NH

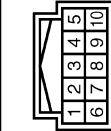

Terminal No.	Color of Wire	Signal Name [Specification]
1	B	GND
6	G	IGN
8	R	ILL+
9	BR	ILL-
10	L	RX(AMP/DISP)

Connector No.	M34
Connector Name	COMBINATION METER
Connector Type	TH40PW-NH



Terminal No.	Color of Wire	Signal Name [Specification]
1	Y	BAT
2	O	IGN
3	B	GROUND
4	B	GROUND
5	SB	ILLUMINATION CONTROL
8	SB	TRIP RESET SWITCH
9	W	SMALL POWER
10	O	METER CONTROL SW GND
11	L	ENTER SWITCH
12	R	SELECT SWITCH
13	V	ILLUMINATION CONTROL SWITCH (SWB automatic drive position)
13	Y	ILLUMINATION CONTROL SWITCH (VW automatic drive position)
14	GR	ILLUMINATION CONTROL SWITCH (-)
15	BR	AIR BAG
18	L	AMBIENT SENSOR
19	P	AMBIENT SENSOR POWER
20	Y	AMBIENT SENSOR GROUND
21	L	CAN-H
22	B	CAN-L
23	P	GROUND
24	W	FUEL LEVEL SENSOR GROUND
25	BR	CHG
26	G	PARKING BRAKE SWITCH
27	V	BRAKE FLUID LEVEL SWITCH
29	R	WASHER LEVEL SWITCH
30	P	VEHICLE SPEED (2-PULSE)
31	V	VEHICLE SPEED (8-PULSE)
32	LG	OD OFF/SPORTS
34	G	FUEL LEVEL SENSOR
35	SB	SEAT BELT BUCKLE SWITCH (DRIVER SIDE)
36	R	SEAT BELT BUCKLE SWITCH (PASSENGER SIDE)

Connector No.	M41
Connector Name	IN-VEHICLE SENSOR
Connector Type	A02FW



Terminal No.	Color of Wire	Signal Name [Specification]
1	LG	-
2	Y	-

Connector No.	M42
Connector Name	INTAKE SENSOR
Connector Type	C02FW



Terminal No.	Color of Wire	Signal Name [Specification]
1	G	-
2	Y	-

Connector No.	M60
Connector Name	A/C AUTO AMP.
Connector Type	ISAB0FW



Terminal No.	Color of Wire	Signal Name [Specification]
1	L	CAN-H
2	P	CAN-L
6	L	TX(AMP/SW&DISP)
7	P	RX(SW&AMP)
10	L	CAN SIG
11	R	VACTR
15	O	SUN SENS
16	G	INTAKE SENS
17	R	ACC
19	B	GND
20	G	IGN
26	GR	RR DEF F/B
27	BR	RR DEF ON
32	L	FAN PWM
34	P	AMB POWER
35	L	AMB SENS
36	LG	INCAR SENS
37	Y	SENS GND
39	B	GND(POWER)
40	Y	BAT

# A/C AUTO AMP.

< ECU DIAGNOSIS INFORMATION >

[WITHOUT 7 INCH DISPLAY]

## AUTOMATIC AIR CONDITIONING SYSTEM

Connector No.	M74
Connector Name	SUNLOAD SENSOR
Connector Type	K02PE



Terminal No.	Color of Wire	Signal Name [Specification]
1	O	-
2	Y	-

Connector No.	M77
Connector Name	WIRE TO WIRE
Connector Type	TH00FW-C319

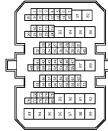

Terminal No.	Color of Wire	Signal Name [Specification]
1	SHIELD	-
2	B	-
3	W	-
4	R	-
5	Y	-
6	W	-
7	G	-
8	SHIELD	-
9	W	-
10	R	-
11	G	-
12	B	-
13	O	-
14	R	-
15	SB	-
16	R	-
17	V	-
18	P	-
19	P	-
20	LG	-

79	B	-
80	W	-
81	LG	-
82	L	-
83	W	- [With automatic drive positioner]
84	GR	- [With driver side power seat]
85	R	-
86	Y	- [With front heated seat and passenger side power seat]
87	GR	- [With front heated seat without passenger side power seat]
88	R	-
89	B	-
90	G	-
91	G	-
92	BR	-
93	P	-
94	V	-
95	O	-
96	SB	-
97	L	-
98	LG	-
99	Y	-

Connector No.	M84
Connector Name	WIRE TO WIRE
Connector Type	A03MW

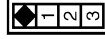

Terminal No.	Color of Wire	Signal Name [Specification]
1	R	-
2	B	-
3	L	-

Connector No.	M85
Connector Name	A/C CONTROL
Connector Type	TH12FW-NH

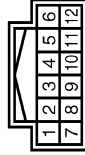

Terminal No.	Color of Wire	Signal Name [Specification]
1	G	IGN
2	B	GND
3	L	RX(AMP-SW)
4	P	TX(SW-AMP)
5	R	ILL*
6	BR	ILL*

Connector No.	M88
Connector Name	BLOWER MOTOR
Connector Type	NS03FW-M3



Terminal No.	Color of Wire	Signal Name [Specification]
1	Y	-
2	L	-
3	B	-

A  
B  
C  
D  
E  
F  
G  
H  
HAC  
J  
K  
L  
M  
N  
O  
P

**AUTOMATIC AIR CONDITIONING SYSTEM**

Connector No.	M125
Connector Name	MULTIFUNCTION SWITCH
Connector Type	TH16FW-NH

2	4	6	8	10	12	14	16
1	3	5	7	9	11	13	15



55	SHIELD	SHIELD
56	R	COMM (CONT->DISP)
57	R	VP
58	BR	INVERTER GND
59	Y	INVERTER VCC

Connector No.	M131
Connector Name	AV CONTROL UNIT WITH BOSE SYSTEM WITHOUT NAVIGATION SYSTEM
Connector Type	TH32FW-NH

91	90	89	88	87	86	85	84	83	82	81	80	79	78	77	76
107	106	105	104	103	102	101	100	99	98	97	96	95	94	93	92



Terminal No.	Color of Wire	Signal Name [Specification]
79	L	TEL VOICE SIGNAL (-)
80	R	TEL VOICE SIGNAL (+)
81	SHIELD	SHIELD
82	W	SOUND SIGNAL RH (-) [With DVD Player]
82	W	IPed SOUND SIGNAL RH (-) [Without DVD Player]
83	R	SOUND SIGNAL RH (+) [With DVD Player]
83	R	IPed SOUND SIGNAL RH (+) [Without DVD Player]
85	B	GND
86	L	CAN-H
87	P	CAN-L
88	R	AV COMM (H)
89	L	AV COMM (L)
90	G	AV COMM (H)
91	L	AV COMM (L)
95	R	AUX SOUND SIGNAL RH (+)
96	B	AUX SOUND SIGNAL LH (+)
97	W	AUX SOUND SIGNAL GND
98	G	SOUND SIGNAL LH (-) [With DVD Player]
98	L	IPed SOUND SIGNAL LH (-) [Without DVD Player]
99	B	SOUND SIGNAL LH (+) [With DVD Player]
99	BR	IPed SOUND SIGNAL LH (+) [Without DVD Player]
100	SHIELD	SHIELD [With DVD player]
100	SHIELD	SHIELD [Without DVD player]
101	V	SW GND
103	W	EJECT SIGNAL
104	G	IGNITION
105	SB	REVERSE
106	G	PARKING BRAKE
107	V	VEHICLE SPEED (8-PULSE)

Connector No.	M129
Connector Name	AV CONTROL UNIT WITH BOSE SYSTEM WITHOUT NAVIGATION SYSTEM
Connector Type	TH24FW-NH

47	46	45	44	43	42	41	40	39	38	37	36
59	58	57	56	55	54	53	52	51	50	49	48



Terminal No.	Color of Wire	Signal Name [Specification]
36	L	COMPOSITE IMAGE SIGNAL
37	P	COMPOSITE IMAGE GND
38	Y	RGB (BLUE) SIGNAL
39	L	RGB (GREEN) SIGNAL
40	G	RGB (RED) SIGNAL
41	B	RGB SYNC
42	SHIELD	SHIELD
43	W	RGB AREA (YS) SIGNAL
44	G	COMM (DISP->CONT)
45	G	HP
46	LG	SIGNAL GND
47	O	SIGNAL VCC
48	SHIELD	SHIELD
50	SHIELD	SHIELD

Connector No.	M145
Connector Name	AV CONTROL UNIT (WITH NAVIGATION SYSTEM)
Connector Type	TH40FW-NH

22	23	24	25	26	27	28	29	30	31	32	33	34	35	36	37	38	39	40	41	42	43	44	45	46	47	48	49	50	51	52	53	54	55	56	57	58	59	60
----	----	----	----	----	----	----	----	----	----	----	----	----	----	----	----	----	----	----	----	----	----	----	----	----	----	----	----	----	----	----	----	----	----	----	----	----	----	----



Terminal No.	Color of Wire	Signal Name [Specification]
21	B	GND
22	Y	BATTERY
23	B	GND
24	Y	BATTERY
25	R	ACC
26	B	MICROPHONE VCC
27	SHIELD	MICROPHONE GND
28	W	MICROPHONE SIGNAL
35	G	IGNITION
36	G	PARKING BRAKE
37	SB	REVERSE
38	V	VEHICLE SPEED (8-PULSE)
40	P	CONNECTION RECOGNITION
42	B	CONTROL SIGNAL
43	B	CONTROL SIGNAL
48	G	AV COMM (H)
49	L	AV COMM (L)
50	R	AV COMM (H)
51	L	AV COMM (L)
52	L	CAN-H
53	P	CAN-L

Connector No.	M146
Connector Name	AV CONTROL UNIT (WITH NAVIGATION SYSTEM)
Connector Type	TH12FW-NH

62	64	66	68	70	72
61	63	65	67	69	71



Terminal No.	Color of Wire	Signal Name [Specification]
61	G	RGB (RED) SIGNAL

62	R	RGB (GREEN) SIGNAL
63	W	RGB (BLUE) SIGNAL
64	SHIELD	SHIELD
65	B	RGB SYNC
66	SHIELD	SHIELD
67	W	RGB AREA (YS) SIGNAL
68	B	HP
69	R	VP
70	R	COMM (CONT->DISP)
71	G	COMM (DISP->CONT)
72	SHIELD	SHIELD

Connector No.	M302
Connector Name	WIRE TO WIRE
Connector Type	AQ3FW

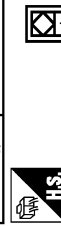

1	2	3
---	---	---

Terminal No.	Color of Wire	Signal Name [Specification]
1	-	-
2	-	-
3	-	-

Connector No.	M304
Connector Name	INTAKE DOOR MOTOR
Connector Type	AQ3FW



1	2	3
---	---	---

Terminal No.	Color of Wire	Signal Name [Specification]
1	-	-
2	-	-
3	-	-



A  
B  
C  
D  
E  
F  
G  
H  
HAC  
J  
K  
L  
M  
N  
O  
P

**AUTOMATIC AIR CONDITIONING SYSTEM**

Connector No.	M306
Connector Name	AIR MIX DOOR MOTOR LH
Connector Type	A03FW

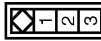

Terminal No.	Color of Wire	Signal Name [Specification]
1	-	-
2	-	-
3	-	-

Connector No.	M307
Connector Name	AIR MIX DOOR MOTOR RH
Connector Type	A03FW

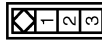

Terminal No.	Color of Wire	Signal Name [Specification]
1	-	-
2	-	-
3	-	-

Connector No.	M308
Connector Name	UPPER VENT DOOR MOTOR
Connector Type	A03FW

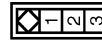

Terminal No.	Color of Wire	Signal Name [Specification]
1	-	-
2	-	-
3	-	-

1	-
2	-
3	-

Connector No.	M310
Connector Name	MODE DOOR MOTOR
Connector Type	A03FW

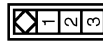

Terminal No.	Color of Wire	Signal Name [Specification]
1	-	-
2	-	-
3	-	-

JCIWM0579GB

INFOID:000000005514649

**Fail-Safe**

**FAIL-SAFE FUNCTION**

If a communication error exists between the A/C auto amp. and A/C control for 30 seconds or longer, air conditioner is controlled under the following conditions:

# A/C AUTO AMP.

< ECU DIAGNOSIS INFORMATION >

[WITHOUT 7 INCH DISPLAY]

**Compressor** : ON  
**Air outlet** : AUTO  
**Air inlet** : FRE (Fresh air intake)  
**Fan speed** : AUTO  
**Set temperature** : Setting before communication error occurs

## DTC Inspection Priority Chart

INFOID:000000005514650

If some DTCs are displayed at the same time, perform inspections one by one based on the following priority chart.

Priority	Detected items (DTC)
1	<ul style="list-style-type: none"> <li>U1000: CAN COMM CIRCUIT</li> <li>U1010: CONTROL UNIT (CAN)</li> </ul>
2	<ul style="list-style-type: none"> <li>B257B: AMB TEMP SEN SHORT</li> <li>B257C: AMB TEMP SEN OPEN</li> <li>B2578: IN CAR SEN SHORT</li> <li>B2579: IN CAR SEN OPEN</li> <li>B2581: EVAP TEMP SEN SHORT</li> <li>B2582: EVAP TEMP SEN OPEN</li> <li>B2630: SUNLOAD SEN SHORT</li> <li>B2631: SUNLOAD SEN OPEN</li> <li>B2632: DR AIRMIX ACTR SHORT</li> <li>B2633: DR AIRMIX ACTR OPEN</li> <li>B2634: PASS AIRMIX ACTR SHORT</li> <li>B2635: PASS AIRMIX ACTR OPEN</li> <li>B2636: DR VENT DOOR FAIL</li> <li>B2637: DR B/L DOOR FAIL</li> <li>B2638: DR D/F1 DOOR FAIL</li> <li>B2639: DR DEF DOOR FAIL</li> <li>B263D: FRE DOOR FAIL</li> <li>B263E: 20P FRE DOOR FAIL</li> <li>B263F: REC DOOR FAIL</li> <li>B2654: D/F2 DOOR FAIL</li> <li>B2655: B/L2 DOOR FAIL</li> <li>B2661: UPPER VENT DOOR OPEN POSI FAIL</li> <li>B2662: UPPER VENT DOOR MID POSI FAIL</li> <li>B2663: UPPER VENT DOOR SHUT POSI FAIL</li> </ul>

## DTC Index

INFOID:000000005514651

DTC	Items (CONSULT-III screen terms)	Reference
U1000	CAN COMM CIRCUIT	<a href="#">HAC-43, "DTC Logic"</a>
U1010	CONTROL UNIT (CAN)	<a href="#">HAC-44, "DTC Logic"</a>
B257B	AMB TEMP SEN SHORT	<a href="#">HAC-45, "DTC Logic"</a>
B257C	AMB TEMP SEN OPEN	<a href="#">HAC-45, "DTC Logic"</a>
B2578	IN CAR SEN SHORT	<a href="#">HAC-48, "DTC Logic"</a>
B2579	IN CAR SEN OPEN	<a href="#">HAC-48, "DTC Logic"</a>
B2581	EVAP TEMP SEN SHORT	<a href="#">HAC-51, "DTC Logic"</a>
B2582	EVAP TEMP SEN OPEN	<a href="#">HAC-51, "DTC Logic"</a>
B2630*	SUNLOAD SEN SHORT	<a href="#">HAC-54, "DTC Logic"</a>
B2631*	SUNLOAD SEN OPEN	<a href="#">HAC-54, "DTC Logic"</a>
B2632	DR AIRMIX ACTR SHORT	<a href="#">HAC-57, "DTC Logic"</a>
B2633	DR AIRMIX ACTR OPEN	<a href="#">HAC-57, "DTC Logic"</a>

# A/C AUTO AMP.

< ECU DIAGNOSIS INFORMATION >

[WITHOUT 7 INCH DISPLAY]

DTC	Items (CONSULT-III screen terms)	Reference
B2634	PASS AIRMIX ACTR SHORT	<a href="#">HAC-59, "DTC Logic"</a>
B2635	PASS AIRMIX ACTR OPEN	<a href="#">HAC-59, "DTC Logic"</a>
B2636	DR VENT DOOR FAIL	<a href="#">HAC-61, "DTC Logic"</a>
B2637	DR B/L DOOR FAIL	<a href="#">HAC-61, "DTC Logic"</a>
B2638	DR D/F1 DOOR FAIL	<a href="#">HAC-61, "DTC Logic"</a>
B2639	DR DEF DOOR FAIL	<a href="#">HAC-61, "DTC Logic"</a>
B263D	FRE DOOR FAIL	<a href="#">HAC-64, "DTC Logic"</a>
B263E	20P FRE DOOR FAIL	<a href="#">HAC-64, "DTC Logic"</a>
B263F	REC DOOR FAIL	<a href="#">HAC-64, "DTC Logic"</a>
B2654	D/F2 DOOR FAIL	<a href="#">HAC-61, "DTC Logic"</a>
B2655	B/L2 DOOR FAIL	<a href="#">HAC-61, "DTC Logic"</a>
B2661	UPPER VENT DOOR OPEN POSI FAIL	<a href="#">HAC-66, "DTC Logic"</a>
B2662	UPPER VENT DOOR MID POSI FAIL	<a href="#">HAC-66, "DTC Logic"</a>
B2663	UPPER VENT DOOR SHUT POSI FAIL	<a href="#">HAC-66, "DTC Logic"</a>

\*: Perform self-diagnosis under sunshine. When performing indoors, aim a light (more than 60 W) at sunload sensor, otherwise self-diagnosis indicates even though the sunload sensor is functioning normally.

A  
B  
C  
D  
E  
F  
G  
H  
J  
K  
L  
M  
N  
O  
P

HAC

# AIR CONDITIONER CONTROL

< SYMPTOM DIAGNOSIS >

[WITHOUT 7 INCH DISPLAY]

## SYMPTOM DIAGNOSIS

### AIR CONDITIONER CONTROL

#### Diagnosis Chart By Symptom

INFOID:000000005514652

Symptom	Reference	
A/C system does not activate.	Go to Trouble Diagnosis Procedure for A/C Control Signal Circuit.	<a href="#">HAC-75. "Diagnosis Procedure"</a>
A/C display dose not work.	Go to Trouble Diagnosis Procedure for A/C Display.	<a href="#">HAC-78. "A/C DISPLAY : Diagnosis Procedure"</a>
Air outlet does not change.	Go to Trouble Diagnosis Procedure for Mode Door Motor. (LAN)	<a href="#">HAC-62. "Diagnosis Procedure"</a>
Mode door motor does not operate normally.		
Discharge air temperature does not change.	Go to Trouble Diagnosis Procedure for Air Mix Door Motor. (LAN)	<a href="#">HAC-58. "Diagnosis Procedure"</a> (driver side) or <a href="#">HAC-60. "Diagnosis Procedure"</a> (passenger side)
Air mix door motor does not operate normally.		
Intake door does not change.	Go to Trouble Diagnosis Procedure for Intake Door Motor. (LAN)	<a href="#">HAC-65. "Diagnosis Procedure"</a>
Intake door motor does not operate normally.		
Blower motor operation is malfunctioning.	Go to Trouble Diagnosis Procedure for Blower Motor.	<a href="#">HAC-69. "Diagnosis Procedure"</a>
Magnet clutch does not engage.	Go to Trouble Diagnosis Procedure for Magnet Clutch.	<a href="#">HAC-73. "Diagnosis Procedure"</a>
Insufficient cooling	Go to Trouble Diagnosis Procedure for Insufficient Cooling.	<a href="#">HAC-109. "Inspection procedure"</a>
No cool air comes out. (Air flow volume is normal.)		
Insufficient heating	Go to Trouble Diagnosis Procedure for Insufficient Heating.	<a href="#">HAC-112. "Inspection procedure"</a>
No warm air comes out. (Air flow volume is normal.)		
Noise	Go to Trouble Diagnosis Procedure for Noise.	<a href="#">HAC-115. "Inspection procedure"</a>
Memory function does not operate.	Go to Trouble Diagnosis Procedure for Memory Function.	<a href="#">HAC-117. "Inspection procedure"</a>

# INSUFFICIENT COOLING

[WITHOUT 7 INCH DISPLAY]

< SYMPTOM DIAGNOSIS >

## INSUFFICIENT COOLING

### Description

INFOID:000000005514653

#### Symptom

- Insufficient cooling
- No cool air comes out. (Air flow volume is normal.)

### Inspection procedure

INFOID:000000005514654

#### 1. CHECK WITH A GAUGE OF RECOVERY/RECYCLING RECHARGING EQUIPMENT

Connect the recovery/recycling recharging equipment to the vehicle and perform the pressure inspection with the gauge.

##### Is there refrigerant?

YES >> GO TO 2.

NO-1 >> Check for refrigerant leakages with the refrigerant leakage detecting fluorescent leak detector. Refer to [HA-30, "Inspection"](#).

NO-2 >> GO TO 2 after repairing or replacing the parts according to the inspection results.

#### 2. CHECK CHARGED REFRIGERANT AMOUNT

1. Connect recovery/recycling recharging equipment to the vehicle and discharge the refrigerant.
2. Recharge with the proper amount of refrigerant and perform the inspection with the refrigerant leakage detecting fluorescent leak detector. Refer to [HA-30, "Inspection"](#).

##### Is the inspection result normal?

YES >> GO TO 3.

NO >> Refill the refrigerant and repair or replace the parts according to the inspection results.

#### 3. CHECK REFRIGERANT CYCLE PRESSURE

Connect recovery/recycling recharging equipment to the vehicle and perform the performance test. Refer to [HA-28, "Performance Chart"](#).

##### Is the inspection result normal?

YES >> GO TO 4.

NO >> Perform the diagnosis with the gauge pressure. Refer to [HA-8, "Trouble Diagnosis For Unusual Pressure"](#).

#### 4. CHECK SETTING OF TEMPERATURE SETTING TRIMMER

Using CONSULT-III, check the setting of "TEMP SET CORRECT" on "WORK SUPPORT" of HVAC. Refer to [HAC-9, "Temperature Setting Trimmer"](#).

1. Check that the temperature setting trimmer is set to "+ direction".

##### **NOTE:**

The control temperature can be set with the setting of the temperature setting trimmer.

2. Set temperature control dial to "0".

##### Are the malfunction solved?

YES >> Perform the setting separately if necessary. END.

NO >> GO TO 5.

#### 5. CHECK WITH SELF-DIAGNOSIS FUNCTION OF CONSULT-III

1. Using CONSULT-III, perform "SELF-DIAGNOSIS RESULTS" of HVAC.
2. Check if any DTC No. is displayed in the trouble diagnosis results.

##### **NOTE:**

If DTC is displayed along with DTC U1000 or U1010, first diagnose the DTC U1000 or U1010. Refer to [HAC-43, "DTC Logic"](#) or [HAC-44, "DTC Logic"](#).

##### Is any DTC No. displayed?

YES >> Perform the diagnosis that is applicable to the sensor and the door motor. Refer to [HAC-106, "DTC Index"](#).

NO >> GO TO 6.

#### 6. CHECK WITH ACTIVE TEST OF CONSULT-III

A

B

C

D

E

F

G

H

HAC

J

K

L

M

N

O

P

# INSUFFICIENT COOLING

< SYMPTOM DIAGNOSIS >

[WITHOUT 7 INCH DISPLAY]

- Using CONSULT-III, perform "HVAC TEST" "ACTIVE TEST" of HVAC to check each output device. Refer to [HAC-39, "CONSULT-III Function"](#).

**NOTE:**

Perform the ACTIVE TEST after starting the engine because the compressor is operated.

- Refer to the table and check the outlet, inlet, air flow temperature, blower motor control signal, magnet clutch operation, and air mix ratio. Visually check each operating condition, by listening for noise, touching air outlets with a hand, etc.

	Test item						
	MODE 1	MODE 2	MODE 3	MODE 4	MODE 5	MODE 6	MODE 7
Mode door position	VENT1	VENT2	B/L1	B/L2	FOOT	D/F	DEF
Intake door position	REC	REC	20%FRE	20%FRE	FRE	FRE	FRE
Air mix door position (driver & passenger side)	FULL COLD	FULL HOT	FULL COLD	FULL HOT	FULL HOT	FULL HOT	FULL HOT
Blower motor duty ratio	35%	35%	61%	61%	81%	81%	35%
Compressor (Magnet clutch)	ON	ON	ON	ON	OFF	OFF	ON
Upper ventilator door	OPEN	SHUT	OPEN	SHUT	SHUT	SHUT	SHUT

**NOTE:**

Perform the inspection of each output device after starting the engine because the compressor is operated.

Discharge air flow							
Mode position indication	Condition	Air outlet/distribution					
		VENT			FOOT		DEF
		Front	Upper	Rear	Front	Rear	
	DUAL switch: OFF UPPER VENT switch : ON	81%	8%	11%	—	—	—
		41%	10%	17%	24%	8%	—
		12%	12%	16%	27%	10%	23%
		11%	11%	14%	25%	10%	29%
		11%	11%	12%	—	—	66%

JPIIA0509GB

Discharge air flow							
Mode position indication	Condition	Air outlet/distribution					
		VENT			FOOT		DEF
		Front	Upper	Rear	Front	Rear	
	DUAL switch: OFF UPPER VENT switch : OFF	88%	—	12%	—	—	—
		47%	—	18%	26%	9%	—
		13%	—	17%	33%	12%	25%
		12%	—	16%	28%	12%	32%
		11%	—	15%	—	—	74%

JPIIA0510GB

Does it operate normally?

YES >> GO TO 7.

# INSUFFICIENT COOLING

< SYMPTOM DIAGNOSIS >

[WITHOUT 7 INCH DISPLAY]

- NO-1 >> Air outlet does not change. Refer to [HAC-62, "Diagnosis Procedure"](#).
- NO-2 >> Air inlet does not change. Refer to [HAC-65, "Diagnosis Procedure"](#).
- NO-3 >> Discharge air temperature does not change. Refer to [HAC-58, "Diagnosis Procedure"](#) and [HAC-60, "Diagnosis Procedure"](#).
- NO-4 >> Blower motor does not operate normally. Refer to [HAC-69, "Diagnosis Procedure"](#).
- NO-5 >> Magnet clutch does not operate. Refer to [HAC-73, "Diagnosis Procedure"](#).

A  
B

## 7. CHECK AMBIENT TEMPERATURE DISPLAY

Check that there is not much difference between actual ambient temperature and indicated temperature on information display in combination meter.

Is the inspection result normal?

- YES >> GO TO 8.
- NO >> Perform the diagnosis for the A/C auto amp. connection recognition signal. Refer to [MWI-55, "Diagnosis Procedure"](#).

C  
D

## 8. CHECK DRIVE BELT

Check tension of the drive belt. Refer to [EM-17, "Checking"](#).

Is the inspection result normal?

- YES >> GO TO 9.
- NO >> Adjust or replace drive belt.

E  
F

## 9. CHECK AIR LEAKAGE FROM DUCT

Check duct and nozzle, etc, of the A/C system for air leakage.

Is the inspection result normal?

- YES >> INSPECTION END
- NO >> Repair or replace parts according to the inspection results.

G  
H

HAC

J  
K  
L  
M  
N  
O  
P

## INSUFFICIENT HEATING

## Description

INFOID:000000005514655

## Symptom

- Insufficient heating
- No warm air comes out. (Air flow volume is normal.)

## Inspection procedure

INFOID:000000005514656

**1.CHECK COOLING SYSTEM**

1. Check engine coolant level and check for leakage. Refer to [CO-11, "Inspection"](#).
2. Check radiator cap. Refer to [CO-15, "RADIATOR CAP : Inspection"](#).
3. Check water flow sounds of engine coolant. Refer to [CO-12, "Refilling"](#).

Is the inspection result normal?

- YES >> GO TO 2.  
NO >> Refill the engine coolant and repair or replace the parts according to the inspection results.

**2.CHECK OPERATION**

1. Press temperature switch (driver side) and raise temperature setting to 32°C (90°F) after warming up the engine.
2. Check that warm air blows from the outlets.

Is the inspection result normal?

- YES >> INSPECTION END  
NO >> GO TO 3.

**3.CHECK SETTING OF TEMPERATURE SETTING TRIMMER**

Using CONSULT-III, check the setting of "TEMP SET CORRECT" on "WORK SUPPORT" of HVAC. Refer to [HAC-9, "Temperature Setting Trimmer"](#).

1. Check that the temperature setting trimmer is set to "– direction".  
**NOTE:**  
The control temperature can be set by the temperature setting trimmer.
2. Set temperature control dial to "0".

Are the malfunction solved?

- YES >> Perform the setting separately if necessary. END.  
NO >> GO TO 4.

**4.CHECK WITH SELF-DIAGNOSIS FUNCTION OF CONSULT-III**

1. Using CONSULT-III, perform "SELF-DIAGNOSIS RESULTS" of HVAC.
2. Check if any DTC No. is displayed in the trouble diagnosis results.

**NOTE:**

If DTC is displayed along with DTC U1000 or U1010, first diagnose the DTC U1000 or U1010. Refer to [HAC-43, "DTC Logic"](#) or [HAC-44, "DTC Logic"](#).

Is any DTC No. displayed?

- YES >> Perform the diagnosis that is applicable to the sensor and the door motor. Refer to [HAC-106, "DTC Index"](#).  
NO >> GO TO 5.

**5.CHECK WITH ACTIVE TEST OF CONSULT-III**

1. Using CONSULT-III, perform "HVAC TEST" in "ACTIVE TEST" of HVAC to check each output device. Refer to [HAC-39, "CONSULT-III Function"](#).

**NOTE:**

Perform the ACTIVE TEST after starting the engine because the compressor is operated.

2. Refer to the table and check the outlet, inlet, air flow temperature, blower motor control signal, magnet clutch operation, and air mix ratio. Visually check each operating condition, by listening for noise, touching air outlets with a hand, etc.



# INSUFFICIENT HEATING

< SYMPTOM DIAGNOSIS >

[WITHOUT 7 INCH DISPLAY]

	Test item						
	MODE 1	MODE 2	MODE 3	MODE 4	MODE 5	MODE 6	MODE 7
Mode door position	VENT1	VENT2	B/L1	B/L2	FOOT	D/F	DEF
Intake door position	REC	REC	20%FRE	20%FRE	FRE	FRE	FRE
Air mix door position (driver & passenger side)	FULL COLD	FULL HOT	FULL COLD	FULL HOT	FULL HOT	FULL HOT	FULL HOT
Blower motor duty ratio	35%	35%	61%	61%	81%	81%	35%
Compressor (Magnet clutch)	ON	ON	ON	ON	OFF	OFF	ON
Upper ventilator door	OPEN	SHUT	OPEN	SHUT	SHUT	SHUT	SHUT

**NOTE:**

Perform the inspection of each output device after starting the engine because the compressor is operated.

Discharge air flow							
Mode position indication	Condition	Air outlet/distribution					
		VENT			FOOT		DEF
		Front	Upper	Rear	Front	Rear	
	DUAL switch: OFF UPPER VENT switch : ON	81%	8%	11%	—	—	—
		41%	10%	17%	24%	8%	—
		12%	12%	16%	27%	10%	23%
		11%	11%	14%	25%	10%	29%
		11%	11%	12%	—	—	66%

JPIIA0509GB

Discharge air flow							
Mode position indication	Condition	Air outlet/distribution					
		VENT			FOOT		DEF
		Front	Upper	Rear	Front	Rear	
	DUAL switch: OFF UPPER VENT switch : OFF	88%	—	12%	—	—	—
		47%	—	18%	26%	9%	—
		13%	—	17%	33%	12%	25%
		12%	—	16%	28%	12%	32%
		11%	—	15%	—	—	74%

JPIIA0510GB

Does it operate normally?

YES >> GO TO 6.

NO-1 >> Air outlet does not change. Refer to [HAC-62, "Diagnosis Procedure"](#).

NO-2 >> Air inlet does not change. Refer to [HAC-65, "Diagnosis Procedure"](#).

NO-3 >> Discharge air temperature does not change. Refer to [HAC-58, "Diagnosis Procedure"](#) and [HAC-60, "Diagnosis Procedure"](#).

NO-4 >> Blower motor does not operate normally. Refer to [HAC-69, "Diagnosis Procedure"](#).

NO-5 >> Magnet clutch does not operate. Refer to [HAC-73, "Diagnosis Procedure"](#).

# INSUFFICIENT HEATING

< SYMPTOM DIAGNOSIS >

[WITHOUT 7 INCH DISPLAY]

---

## 6.CHECK AIR LEAKAGE FROM DUCT

---

Check duct and nozzle, etc, of the A/C system for air leakage.

Is the inspection result normal?

YES >> GO TO 7.

NO >> Repair or replace parts according to the inspection results.

---

## 7.CHECK HEATER HOSE INSTALLATION CONDITION

---

Check the heater hose installation condition visually (for twists, crushes, etc.).

Is the inspection result normal?

YES >> GO TO 8.

NO >> Repair or replace parts according to the inspection results.

---

## 8.CHECK TEMPERATURE OF HEATER HOSE

---

1. Check the temperature of inlet hose and outlet hose of heater core.
2. Check that the inlet side of heater core is hot and the outlet side is slightly lower than/almost equal to the inlet side.

**CAUTION:**

**Always perform the temperature inspection in a short period of time because the engine coolant temperature is very hot.**

Is the inspection result normal?

YES >> GO TO 9.

NO >> Replace the heater core after performing the procedures after the cooling system inspection. GO TO 1.

---

## 9.REPLACE HEATER CORE

---

Replace the heater core. Refer to heater core. Refer to [VTL-45, "Exploded View"](#).

Are the malfunction solved?

YES >> INSPECTION END

NO >> Perform the procedures again after the cooling system inspection. GO TO 1.

**NOISE****Description**

INFOID:000000005514657

## Symptom

- Noise
- Noise is heard when the A/C system operates.

**Inspection procedure**

INFOID:000000005514658

**1.CHECK OPERATION**

1. Operate the A/C system and check the operation. Refer to [HAC-7. "Description & Inspection"](#).
2. Check the parts where noise is occurring.

Can the parts where noise is occurring be checked?

- YES-1 >> Noise from blower motor: GO TO 2.  
 YES-2 >> Noise from compressor: GO TO 3.  
 YES-3 >> Noise from expansion valve: GO TO 4.  
 YES-4 >> Noise from A/C piping (pipe, flexible hose): GO TO 6.  
 YES-5 >> Noise from drive belt: GO TO 7.  
 NO >> INSPECTION END

**2.CHECK BLOWER MOTOR**

1. Remove blower motor.
2. Remove foreign materials that are in the blower unit.
3. Check the noise from blower motor again.

Is the inspection result normal?

- YES >> INSPECTION END  
 NO >> Replace blower motor.

**3.CHECK COMPRESSOR**

Perform trouble diagnosis for the compressor and check the compressor. Refer to [HA-11. "Symptom Table"](#).

Is the inspection result normal?

- YES >> INSPECTION END  
 NO >> Refill the refrigerant or replace the compressor according to the inspection results.

**4.CHECK WITH GAUGE PRESSURE**

Perform the diagnosis with the gauge pressure. Refer to [HA-8. "Trouble Diagnosis For Unusual Pressure"](#).

Is the inspection result normal?

- YES >> GO TO 5.  
 NO >> Repair or replace parts according to the inspection results.

**5.CHECK EXPANSION VALVE**

1. Correct the refrigerant with recovery/recycling recharging equipment.
2. Recharge with the proper amount of the collected refrigerant after recycling or new refrigerant.
3. Check for the noise from expansion valve again.

Are the malfunction solved?

- YES >> INSPECTION END  
 NO >> Replace expansion valve.

**6.CHECK A/C PIPING (PIPE, FLEXIBLE HOSE)**

1. Check the A/C piping (pipes, flexible hoses) (for deformation and damage, etc.).
2. Check the installation condition of clips and brackets, etc, of the A/C piping (pipes, flexible hoses).

Is the inspection result normal?

- YES >> Fix the line with rubber or come vibration absorbing material.  
 NO >> Repair or replace parts according to the inspection results.

**7.CHECK DRIVE BELT**A  
B  
C  
D  
E  
F  
G  
H  
J  
K  
L  
M  
N  
O  
P

HAC

## NOISE

< SYMPTOM DIAGNOSIS >

[WITHOUT 7 INCH DISPLAY]

Check tension of the drive belt. Refer to [EM-17. "Checking"](#).

Is the inspection result normal?

YES >> Check the noise from compressor: GO TO 3.

NO >> Adjust or replace drive belt according to the inspection results.

# MEMORY FUNCTION DOES NOT OPERATE

< SYMPTOM DIAGNOSIS >

[WITHOUT 7 INCH DISPLAY]

## MEMORY FUNCTION DOES NOT OPERATE

### Description

INFOID:000000005514659

#### Symptom

- Memory function does not operate normally.
- The setting is not maintained. (It returns to the initial condition.)

### Inspection procedure

INFOID:000000005514660

#### 1.CHECK OPERATION

1. Set temperature control switch to 32°C (90°F).
2. Press the ON/OFF switch.
3. Turn the ignition switch OFF.
4. Turn the ignition switch ON.
5. Press the AUTO switch.
6. Check that the set temperature is maintained.

#### Is the inspection result normal?

- YES >> INSPECTION END  
NO >> GO TO 2.

#### 2.CHECK POWER SUPPLY AND GROUND CIRCUIT OF A/C AUTO AMP.

Check power supply and ground circuit of the A/C auto amp. Refer to [HAC-76. "A/C AUTO AMP. : Diagnosis Procedure"](#).

#### Is the inspection result normal?

- YES >> Replace the A/C auto amp.  
NO >> Repair or replace malfunctioning parts.

A  
B  
C  
D  
E  
F  
G  
H  
J  
K  
L  
M  
N  
O  
P

HAC

&lt; PRECAUTION &gt;

**PRECAUTION****PRECAUTIONS****FOR USA AND CANADA****FOR USA AND CANADA : Precaution for Supplemental Restraint System (SRS) "AIR BAG" and "SEAT BELT PRE-TENSIONER"**

INFOID:00000000514661

The Supplemental Restraint System such as "AIR BAG" and "SEAT BELT PRE-TENSIONER", used along with a front seat belt, helps to reduce the risk or severity of injury to the driver and front passenger for certain types of collision. This system includes seat belt switch inputs and dual stage front air bag modules. The SRS system uses the seat belt switches to determine the front air bag deployment, and may only deploy one front air bag, depending on the severity of a collision and whether the front occupants are belted or unbelted.

Information necessary to service the system safely is included in the "SRS AIR BAG" and "SEAT BELT" of this Service Manual.

**WARNING:**

- To avoid rendering the SRS inoperative, which could increase the risk of personal injury or death in the event of a collision which would result in air bag inflation, all maintenance must be performed by an authorized NISSAN/INFINITI dealer.
- Improper maintenance, including incorrect removal and installation of the SRS, can lead to personal injury caused by unintentional activation of the system. For removal of Spiral Cable and Air Bag Module, see the "SRS AIR BAG".
- Do not use electrical test equipment on any circuit related to the SRS unless instructed to in this Service Manual. SRS wiring harnesses can be identified by yellow and/or orange harnesses or harness connectors.

**PRECAUTIONS WHEN USING POWER TOOLS (AIR OR ELECTRIC) AND HAMMERS****WARNING:**

- When working near the Air Bag Diagnosis Sensor Unit or other Air Bag System sensors with the ignition ON or engine running, DO NOT use air or electric power tools or strike near the sensor(s) with a hammer. Heavy vibration could activate the sensor(s) and deploy the air bag(s), possibly causing serious injury.
- When using air or electric power tools or hammers, always switch the ignition OFF, disconnect the battery, and wait at least 3 minutes before performing any service.

**FOR MEXICO****FOR MEXICO : Precaution for Supplemental Restraint System (SRS) "AIR BAG" and "SEAT BELT PRE-TENSIONER"**

INFOID:000000005716646

The Supplemental Restraint System such as "AIR BAG" and "SEAT BELT PRE-TENSIONER", used along with a front seat belt, helps to reduce the risk or severity of injury to the driver and front passenger for certain types of collision. Information necessary to service the system safely is included in the "SRS AIR BAG" and "SEAT BELT" of this Service Manual.

**WARNING:**

- To avoid rendering the SRS inoperative, which could increase the risk of personal injury or death in the event of a collision which would result in air bag inflation, all maintenance must be performed by an authorized NISSAN/INFINITI dealer.
- Improper maintenance, including incorrect removal and installation of the SRS, can lead to personal injury caused by unintentional activation of the system. For removal of Spiral Cable and Air Bag Module, see the "SRS AIR BAG".
- Do not use electrical test equipment on any circuit related to the SRS unless instructed to in this Service Manual. SRS wiring harnesses can be identified by yellow and/or orange harnesses or harness connectors.

**PRECAUTIONS WHEN USING POWER TOOLS (AIR OR ELECTRIC) AND HAMMERS****WARNING:**

- When working near the Air Bag Diagnosis Sensor Unit or other Air Bag System sensors with the ignition ON or engine running, DO NOT use air or electric power tools or strike near the sensor(s)

# PRECAUTIONS

< PRECAUTION >

[WITHOUT 7 INCH DISPLAY]

with a hammer. Heavy vibration could activate the sensor(s) and deploy the air bag(s), possibly causing serious injury.

- When using air or electric power tools or hammers, always switch the ignition OFF, disconnect the battery, and wait at least 3 minutes before performing any service.

## Precaution Necessary for Steering Wheel Rotation after Battery Disconnect

INFOID:000000005514663

### NOTE:

- Before removing and installing any control units, first turn the push-button ignition switch to the LOCK position, then disconnect both battery cables.
- After finishing work, confirm that all control unit connectors are connected properly, then re-connect both battery cables.
- Always use CONSULT-III to perform self-diagnosis as a part of each function inspection after finishing work. If a DTC is detected, perform trouble diagnosis according to self-diagnosis results.

For vehicle with steering lock unit, if the battery is disconnected or discharged, the steering wheel will lock and cannot be turned.

If turning the steering wheel is required with the battery disconnected or discharged, follow the operation procedure below before starting the repair operation.

### OPERATION PROCEDURE

1. Connect both battery cables.

#### NOTE:

Supply power using jumper cables if battery is discharged.

2. Turn the push-button ignition switch to ACC position. (At this time, the steering lock will be released.)
3. Disconnect both battery cables. The steering lock will remain released with both battery cables disconnected and the steering wheel can be turned.
4. Perform the necessary repair operation.
5. When the repair work is completed, re-connect both battery cables. With the brake pedal released, turn the push-button ignition switch from ACC position to ON position, then to LOCK position. (The steering wheel will lock when the push-button ignition switch is turned to LOCK position.)
6. Perform self-diagnosis check of all control units using CONSULT-III.

## Precaution for Procedure without Cowl Top Cover

INFOID:000000005514664

When performing the procedure after removing cowl top cover, cover the lower end of windshield with urethane, etc.

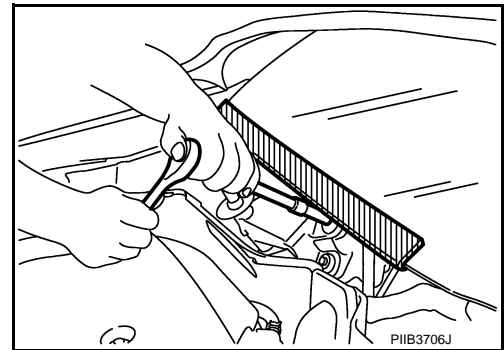

## Precautions For Xenon Headlamp Service

INFOID:000000005514665

### WARNING:

Comply with the following warnings to prevent any serious accident.

- Disconnect the battery cable (negative terminal) or the power supply fuse before installing, removing, or touching the xenon headlamp (bulb included). The xenon headlamp contains high-voltage generated parts.
- Never work with wet hands.
- Check the xenon headlamp ON-OFF status after assembling it to the vehicle. Never turn the xenon headlamp ON in other conditions. Connect the power supply to the vehicle-side connector. (Turning it ON outside the lamp case may cause fire or visual impairments.)
- Never touch the bulb glass immediately after turning it OFF. It is extremely hot.

### CAUTION:

A

B

C

D

E

F

G

H

HAC

J

K

L

M

N

O

P

# PRECAUTIONS

< PRECAUTION >

[WITHOUT 7 INCH DISPLAY]

Comply with the following cautions to prevent any error and malfunction.

- Install the xenon bulb securely. (Insufficient bulb socket installation may melt the bulb, the connector, the housing, etc. by high-voltage leakage or corona discharge.)
- Never perform HID circuit inspection with a tester.
- Never touch the xenon bulb glass with hands. Never put oil and grease on it.
- Dispose of the used xenon bulb after packing it in thick vinyl without breaking it.
- Never wipe out dirt and contamination with organic solvent (thinner, gasoline, etc.).

Working with HFC-134a (R-134a)

INFOID:000000005514666

## CAUTION:

- CFC-12 (R-12) refrigerant and HFC-134a (R-134a) refrigerant are not compatible. Compressor malfunction is likely to occur if the refrigerants are mixed, refer to “CONTAMINATED REFRIGERANT” below. To determine the purity of HFC-134a (R-134a) in the vehicle and recovery tank, use Refrigerant Recovery/Recycling Recharging equipment and Refrigerant Identifier.
- Use only specified lubricant for the HFC-134a (R-134a) A/C system and HFC-134a (R-134a) components. Compressor malfunction is likely to occur if lubricant other than that specified is used.
- The specified HFC-134a (R-134a) lubricant rapidly absorbs moisture from the atmosphere. The following handling precautions must be observed:
  - Immediately cap (seal) the component to minimize the entry of moisture from the atmosphere when removing refrigerant components from a vehicle.
  - Never remove the caps (unseal) until just before connecting the components when installing refrigerant components to a vehicle. Connect all refrigerant loop components as quickly as possible to minimize the entry of moisture into system.
  - Use only the specified lubricant from a sealed container. Immediately reseal containers of lubricant. Lubricant becomes moisture saturated and should not be used without proper sealing.
  - Never allow lubricant (NISSAN A/C System Oil Type S) to come in to contact with styrene foam parts. Damage may result.

## CONTAMINATED REFRIGERANT

Take the appropriate steps shown below if a refrigerant other than pure HFC-134a (R-134a) is identified in a vehicle:

- Explain to the customer that environmental regulations prohibit the release of contaminated refrigerant into the atmosphere.
- Explain that recovery of the contaminated refrigerant could damage service equipment and refrigerant supply.
- Suggest the customer return the vehicle to the location of previous service where the contamination may have occurred.
- If repairing, recover the refrigerant using only **dedicated equipment and containers. Never reintroduce contaminated refrigerant into the existing service equipment.** Contact a local refrigerant product retailer for available service if the facility does not have dedicated recovery equipment. This refrigerant must be disposed of in accordance with all federal and local regulations. In addition, replacement of all refrigerant system components on the vehicle is recommended.
- The air conditioner warranty is void if the vehicle is within the warranty period. Please contact Nissan Customer Affairs for further assistance.

## General Refrigerant Precaution

INFOID:000000005514667

## WARNING:

- Never breath A/C refrigerant, lubricant vapor or mist. Exposure may irritate eyes, nose and throat. Remove HFC-134a (R-134a) from the A/C system, using certified service equipment meeting requirements of SAE J-2210 [HFC-134a (R-134a) recycling equipment], or J-2209 [HFC-134a (R-134a) recovery equipment]. Ventilate work area before resuming service if accidental system discharge occurs. Additional health and safety information may be obtained from refrigerant and lubricant manufacturers.
- Never release refrigerant into the air. Use approved recovery/recycling equipment to capture the refrigerant each time an air conditioning system is discharged.
- Always wear eye and hand protection (goggles and gloves) when working with any refrigerant or air conditioning system.
- Never store or heat refrigerant containers above 52°C (126°F).
- Never heat a refrigerant container with an open flame. Place the bottom of the container in a warm pail of water if container warming is required.



# PRECAUTIONS

[WITHOUT 7 INCH DISPLAY]

## < PRECAUTION >

- Never intentionally drop, puncture, or incinerate refrigerant containers.
- Keep refrigerant away from open flames. Poisonous gas is produced if refrigerant burns.
- Refrigerant displaces oxygen, therefore be certain to work in well ventilated areas to prevent suffocation.
- Never pressure test or leakage test HFC-134a (R-134a) service equipment and/or vehicle air conditioning systems with compressed air during repair. Some mixtures of air and HFC-134a (R-134a) have been shown to be combustible at elevated pressures. These mixtures, if ignited, may cause injury or property damage. Additional health and safety information may be obtained from refrigerant manufacturers.

## Refrigerant Connection

INFOID:000000005514668

A new type refrigerant connection has been introduced to all refrigerant lines except the following location.

- Expansion valve to evaporator
- Refrigerant pressure sensor to liquid tank

## O-RING AND REFRIGERANT CONNECTION

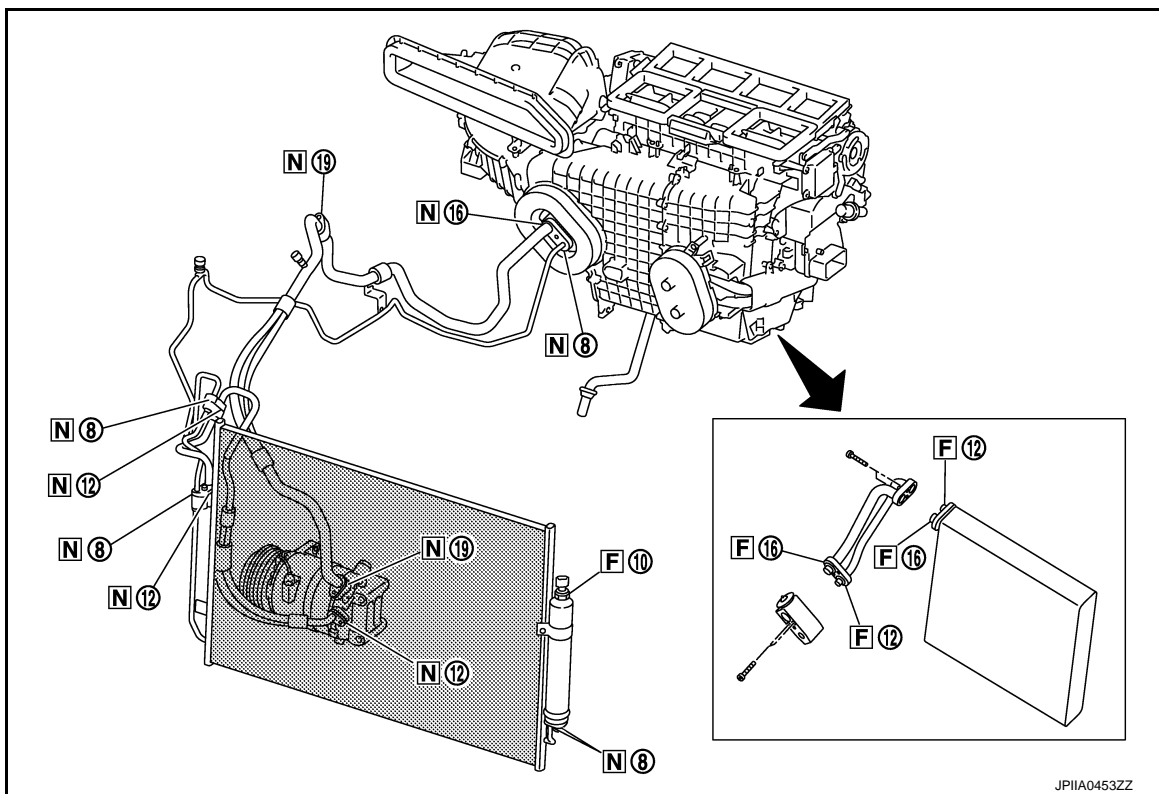

F. Former type refrigerant connection    N. New type refrigerant connection

O: O-ring size

### CAUTION:

The new and former refrigerant connections use different O-ring configurations. Never confuse O-rings since they are not interchangeable. Refrigerant may leak at the connection if a wrong O-ring is installed.

O-Ring Part Numbers and Specifications

# PRECAUTIONS

< PRECAUTION >

[WITHOUT 7 INCH DISPLAY]

Connection type	Piping connection point		Part number	QTY	O-ring size
New	Low-pressure flexible hose to low-pressure pipe		92474 N8210	1	φ19
	High-pressure pipe to condenser pipe assembly (Outlet)		92471 N8210	1	φ8
	Condenser pipe assembly (Inlet) to high-pressure flexible hose (One-touch joint)		92472 N8210	1	φ12
	Condenser assembly to condenser pipe assembly	Inlet	92472 N8210	1	φ12
		Outlet	92471 N8210	1	φ8
	Low-pressure pipe to expansion valve		92473 N8210	1	φ16
	High-pressure pipe to expansion valve		92471 N8210	1	φ8
	Compressor to low-pressure flexible hose		92474 N8210	1	φ19
	Compressor to high-pressure flexible hose		92472 N8210	1	φ12
	Liquid tank to condenser assembly	Inlet	92471 N8210	1	φ8
Outlet		1			
Former	Refrigerant pressure sensor to liquid tank		J2476 89956	1	φ10
	Expansion valve to evaporator pipe assembly	Inlet	92475 71L00	1	φ12
		Outlet	92475 72L00	1	φ16
	Evaporator to evaporator pipe assembly	Inlet	92475 71L00	1	φ12
		Outlet	92475 72L00	1	φ16

**WARNING:**

Check that all refrigerant is discharged into the recycling equipment and the pressure in the system is less than atmospheric pressure. Then gradually loosen the discharge side hose fitting and remove it.

**CAUTION:**

Observe the following when replacing or cleaning refrigerant cycle components.

- Store it in the same way as it is when mounted on the car when the compressor is removed. Failure to do so will cause lubricant to enter the low-pressure chamber.
- Always use a torque wrench and a back-up wrench when connecting tubes.
- Immediately plug all openings to prevent entry of dust and moisture after disconnecting tubes.
- Connect the pipes at the final stage of the operation when installing an air conditioner in the vehicle. Never remove the seal caps of pipes and other components until just before required for connection.
- Allow components stored in cool areas to warm to working area temperature before removing seal caps. This prevents condensation from forming inside A/C components.
- Thoroughly remove moisture from the refrigeration system before charging the refrigerant.
- Replace always used O-rings.
- Apply lubricant to circle of the O-rings shown in illustration when connecting tube. Be careful not to apply lubricant to threaded portion.

Name : NISSAN A/C System Oil Type S

- O-ring must be closely attached to the groove portion of tube.
- Be careful not to damage O-ring and tube when replacing the O-ring.
- Connect tube until a click can be heard. Then tighten the nut or bolt by hand. Check that the O-ring is installed to tube correctly.

# PRECAUTIONS

< PRECAUTION >

[WITHOUT 7 INCH DISPLAY]

- Perform leakage test and make sure that there is no leakage from connections after connecting line. Disconnect the line and replace the O-ring when the refrigerant leaking point is found. Then tighten the connections of seal seat to the specified torque.

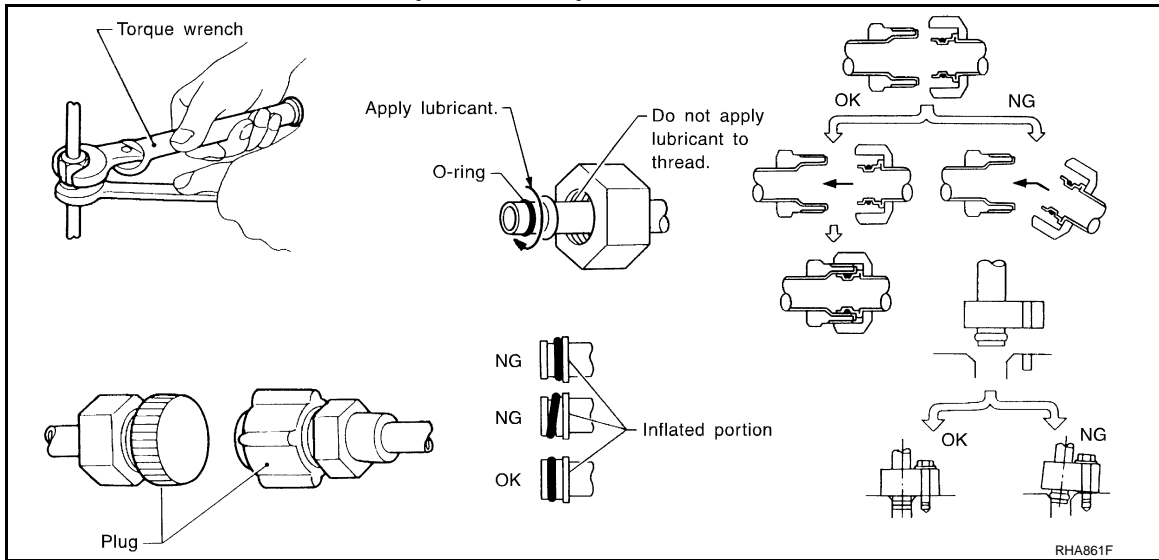

## Service Equipment

INFOID:00000000514669

### RECOVERY/RECYCLING EQUIPMENT

Be certain to follow the manufacturer instructions for machine operation and machine maintenance. Never introduce any refrigerant other than that specified into the machine.

### ELECTRICAL LEAK DETECTOR

Be certain to follow the manufacturer instructions for tester operation and tester maintenance.

### VACUUM PUMP

The lubricant contained inside the vacuum pump is not compatible with the specified lubricant for HFC-134a (R-134a) A/C systems. The vent side of the vacuum pump is exposed to atmospheric pressure. So the vacuum pump lubricant may migrate out of the pump into the service hose. This is possible when the pump is switched OFF after evacuation (vacuuming) and hose is connected to it. To prevent this migration, use a manual valve placed near the hose-to-pump connection, as per the following.

- Vacuum pumps usually have a manual isolator valve as part of the pump. Close this valve to isolate the service hose from the pump.
- Use a hose equipped with a manual shut-off valve near the pump end for pumps without an isolator. Close the valve to isolate the hose from the pump.
- Disconnect the hose from the pump if the hose has an automatic shut-off valve. As long as the hose is connected, the valve is open and lubricating oil may migrate.

Some one-way valves open when vacuum is applied and close under no vacuum condition. Such valves may restrict the ability of the pump to create a deep vacuum and are not recommended.

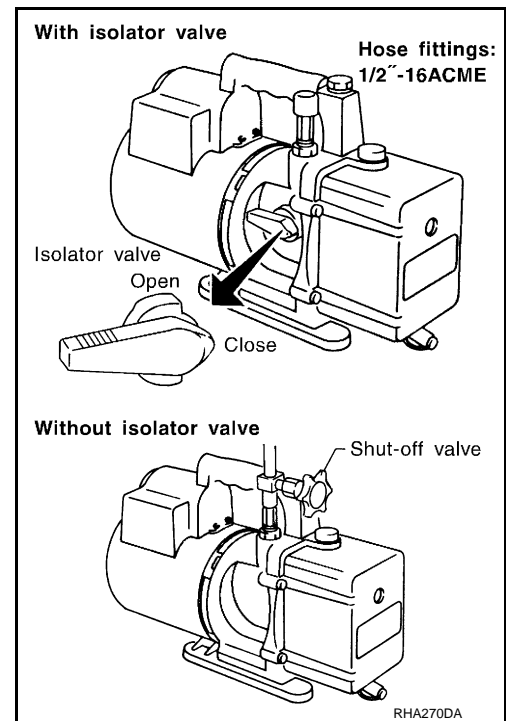

### MANIFOLD GAUGE SET

# PRECAUTIONS

## < PRECAUTION >

Be certain that the gauge face indicates HFC-134a or R-134a. Be sure the gauge set has 1/2"-16 ACME threaded connections for service hoses. Confirm the set has been used only with refrigerant HFC-134a (R-134a) and specified lubricants.

[WITHOUT 7 INCH DISPLAY]

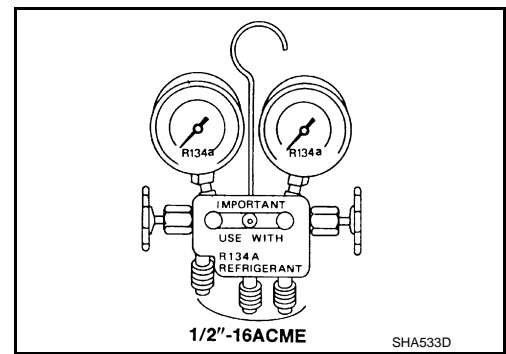

## SERVICE HOSES

Be certain that the service hoses display the markings described (colored hose with a black stripe). All hoses must equip positive shut-off devices (either manual or automatic) near the end of the hoses opposite to the manifold gauge.

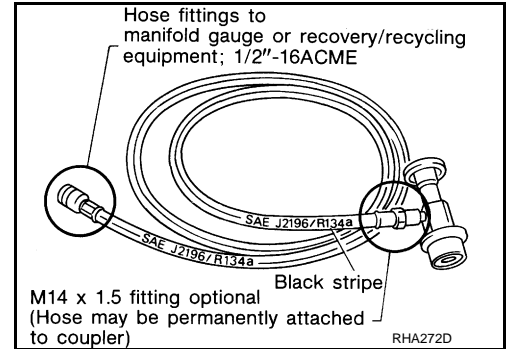

## SERVICE COUPLERS

Never attempt to connect HFC-134a (R-134a) service couplers to a CFC-12 (R-12) A/C system. The HFC-134a (R-134a) couplers do not properly connect to the CFC-12 (R-12) system. However, if an improper connection is attempted, discharge and contamination may occur.

Shut-off valve rotation	A/C service valve
Clockwise	Open
Counterclockwise	Close

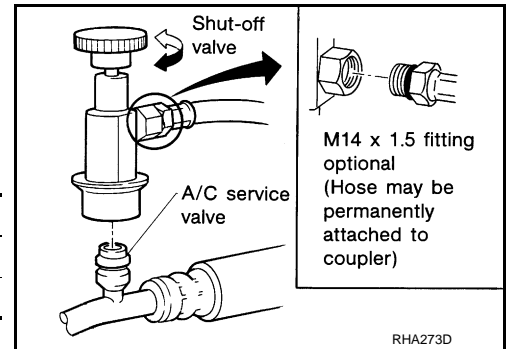

## REFRIGERANT WEIGHT SCALE

Verify that no refrigerant other than HFC-134a (R-134a) and specified lubricants have been used with the scale. The hose fitting must be 1/2"-16 ACME if the scale controls refrigerant flow electronically.

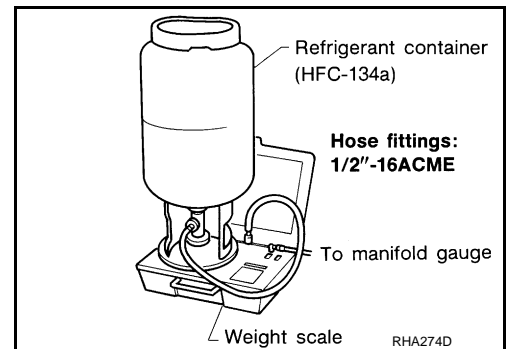

## CHARGING CYLINDER

Use of a charging cylinder is not recommended. Refrigerant may be vented into the air from the top valve of the cylinder when filling the cylinder with refrigerant. Also, the accuracy of the cylinder is generally less than that of an electronic scale or of quality recycle/recharge equipment.

## COMPRESSOR

### General Precautions

INFOID:000000005514670

**CAUTION:**

- Plug all openings to prevent moisture and foreign matter from entering.
- Store it in the same way as it is when mounted on the car when the compressor is removed.
- Follow “Maintenance of Lubricant Quantity in Compressor” exactly when replacing or repairing the compressor. Refer to [HA-25, "Maintenance of Lubricant Quantity"](#).
- Keep friction surfaces between clutch and pulley clean. Wipe it off by using a clean waste cloth moistened with thinner if the surface is contaminated with lubricant.
- Turn the compressor shaft by hand more than five turns in both directions after compressor service operation. This equally distributes lubricant inside the compressor. Let the engine idle and operate the compressor for one hour after the compressor is installed.
- Apply voltage to the new compressor and check for normal operation after replacing the compressor magnet clutch.

A  
B  
C  
D  
E  
F  
G  
H  
J  
K  
L  
M  
N  
O  
P

HAC

# FLUORESCENT LEAK DETECTOR

< PRECAUTION >

[WITHOUT 7 INCH DISPLAY]

## FLUORESCENT LEAK DETECTOR

### General Precautions

INFOID:000000005514671

#### CAUTION:

- The A/C system contains a fluorescent leak detection dye used for locating refrigerant leakages. An ultraviolet (UV) lamp is required to illuminate the dye when inspecting for leakages.
- Always wear fluorescence enhancing UV safety goggles to protect eyes and enhance the visibility of the fluorescent dye.
- The fluorescent dye leak detector is not a replacement for an electrical leak detector (SST: J-41995). The fluorescent dye leak detector should be used in conjunction with an electrical leak detector (SST: J-41995) to pin-point refrigerant leakages.
- Read and follow all manufacture operating instructions and precautions prior to performing the work for the purpose of safety and customer satisfaction.
- A compressor shaft seal should not necessarily be repaired because of dye seepage. The compressor shaft seal should only be repaired after confirming the leakage with an electrical leak detector (SST: J-41995).
- Always remove any remaining dye from the leakage area after repairs are completed to avoid a misdiagnosis during future service.
- Never allow dye to come into contact with painted body panels or interior components. Clean immediately with the approved dye cleaner if dye is spilled. Fluorescent dye left on a surface for an extended period of time cannot be removed.
- Never spray the fluorescent dye cleaning agent on hot surfaces (engine exhaust manifold, etc.).
- Never use more than one refrigerant dye bottle (1/4 ounce /7.4 cc) per A/C system.
- Leak detection dyes for HFC-134a (R-134a) and CFC-12 (R-12) A/C systems are different. Never use HFC-134a (R-134a) leak detection dye in CFC-12 (R-12) A/C system, or CFC-12 (R-12) leak detection dye in HFC-134a (R-134a) A/C system, or A/C system damage may result.
- The fluorescent properties of the dye remains for three or more years unless a compressor malfunction occurs.

### IDENTIFICATION

#### NOTE:

Vehicles with factory installed fluorescent dye have a green label.

Vehicles without factory installed fluorescent dye have a blue label.

### IDENTIFICATION LABEL FOR VEHICLE

Vehicles with factory installed fluorescent dye have an identification label on the front side of hood.

## BASIC INSPECTION

### DIAGNOSIS AND REPAIR WORKFLOW

#### Work Flow

INFOID:000000005514672

#### OVERALL SEQUENCE

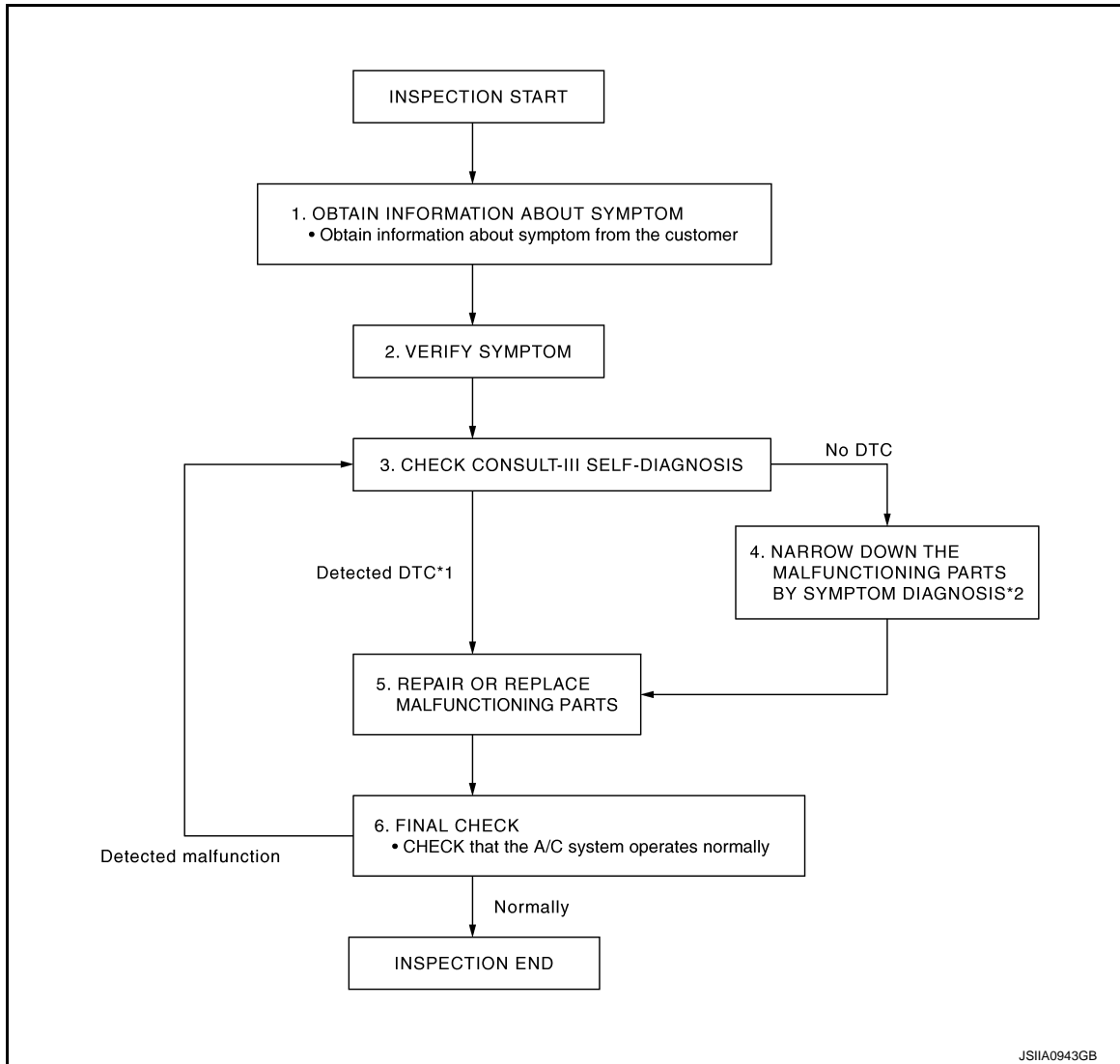

\*1: Refer to [HAC-226. "DTC Index"](#).

\*2: Refer to [HAC-228. "Diagnosis Chart By Symptom"](#).

#### DETAILED FLOW

##### 1. OBTAIN INFORMATION ABOUT SYMPTOM

Interview the customer to obtain as much information as possible about the conditions and environment under which the malfunction occurred.

>> GO TO 2.

##### 2. VERIFY SYMPTOM

Verify the symptom with operational check based on the information obtained from the customer. Refer to [HAC-129. "Description & Inspection"](#).

>> GO TO 3.

## DIAGNOSIS AND REPAIR WORKFLOW

< BASIC INSPECTION >

[WITH 7 INCH DISPLAY]

---

### 3. CHECK WITH SELF-DIAGNOSIS FUNCTION OF CONSULT-III

---

Using CONSULT-III, perform "SELF-DIAGNOSIS RESULTS" of HVAC. Refer to [HAC-226, "DTC Index"](#).

Are self-diagnosis results normal?

YES >> GO TO 4.

NO >> GO TO 5.

---

### 4. NARROW DOWN THE MALFUNCTIONING PARTS BY SYMPTOM DIAGNOSIS

---

Perform symptom diagnosis and narrow down the malfunctioning parts. Refer to [HAC-228, "Diagnosis Chart By Symptom"](#).

>> GO TO 5.

---

### 5. REPAIR OR REPLACE

---

Repair or replace malfunctioning parts.

**NOTE:**

If DTC is displayed, erase DTC after repairing or replacing malfunctioning parts.

>> GO TO 6.

---

### 6. FINAL CHECK

---

Check that the A/C system operates normally.

Is the inspection result normal?

YES >> INSPECTION END

NO >> GO TO 3.



## INSPECTION AND ADJUSTMENT

## Description &amp; Inspection

INFOID:000000005514673

## DESCRIPTION

The purpose of the operational check is to check that the individual system operates normally.

**Conditions : Engine running at normal operating temperature**

## INSPECTION PROCEDURE

**1.**CHECK MEMORY FUNCTION

1. Start the engine.
2. Operate the temperature control dial (driver side) and raise the temperature setting to 32°C (90°F).
3. Press the ON/OFF switch.
4. Turn the ignition switch OFF.
5. Turn the ignition switch ON.
6. Press the AUTO switch.
7. Check that the temperature setting before turning the ignition switch OFF is stored.

Is the inspection result normal?

YES >> GO TO 2.

NO >> Memory function malfunction: [HAC-237, "Inspection procedure"](#).

**2.**CHECK BLOWER MOTOR SPEED

1. Start the engine.
2. Operate the fan control dial. Check that the fan speed changes. Check the operation for all fan speeds.
3. Set the fan speed to speed 7.

Is the inspection result normal?

YES >> GO TO 3.

NO >> Blower motor system malfunction: [HAC-191, "Diagnosis Procedure"](#).

**3.**CHECK DISCHARGE AIR(MODE SWITCH AND DEF SWITCH)

1. Press the MODE switch and the DEF switch.
2. Check that the air outlets change according to each indicated air outlet by placing a hand in front of the outlets. Refer to [HAC-138, "System Description"](#).

**NOTE:**

Confirm that the compressor clutch is engaged (sound or visual inspection) and intake door position is at FRE when the D/F or DEF is selected.

Is the inspection result normal?

YES >> GO TO 4.

NO >> Mode door system malfunction: [HAC-184, "Diagnosis Procedure"](#).

**4.**CHECK DISCHARGE AIR (UPPER VENT SWITCH)

1. Press the UPPER VENT switch.
2. The UPPER VENT switch indicator is turned ON.

A  
B  
C  
D  
E  
F  
G  
H  
HAC  
J  
K  
L  
M  
N  
O  
P

# INSPECTION AND ADJUSTMENT

< BASIC INSPECTION >

[WITH 7 INCH DISPLAY]

3. Check that the air blown from UPPER VENT does not greatly deviate from the air mix ratio.

Discharge air flow							
Mode position indication	Condition	Air outlet/distribution					
		VENT			FOOT		DEF
		Front	Upper	Rear	Front	Rear	
	DUAL switch: OFF UPPER VENT switch : ON	81%	8%	11%	—	—	—
		41%	10%	17%	24%	8%	—
		12%	12%	16%	27%	10%	23%
		11%	11%	14%	25%	10%	29%
		11%	11%	12%	—	—	66%

JPIIA0509GB

4. Press the UPPER VENT switch again.
5. The UPPER VENT switch indicator is turned OFF.
6. The air blown from the UPPER VENT stops.

Does it operate normally?

YES >> GO TO 5.

NO >> Upper ventilator door system malfunction: [HAC-189, "Diagnosis Procedure"](#).

## 5. CHECK INTAKE AIR

1. Press the intake switch. Indicator is turned ON (REC).
2. Press the intake switch again. Indicator is turned OFF (FRE).
3. Listen for the intake door position change. (Slight change of blower sound can be heard.)

**NOTE:**

Confirm that the compressor clutch is engaged (sound or visual inspection) and intake door position is at FRE when the D/F or DEF is selected.

Is the inspection result normal?

YES >> GO TO 6.

NO >> Intake door system malfunction: [HAC-187, "Diagnosis Procedure"](#).

## 6. CHECK A/C SWITCH

1. Press the A/C switch.
2. The A/C switch indicator is turned ON.  
Confirm that the compressor clutch engages (sound or visual inspection).

Is the inspection result normal?

YES >> GO TO 7.

NO >> Magnet clutch system malfunction: [HAC-195, "Diagnosis Procedure"](#).

## 7. CHECK WITH TEMPERATURE SETTING LOWERED

1. Operate the compressor.
2. Operate the temperature control switch (driver side) and lower the temperature setting to 18°C (60°F).
3. Check that the cool air blows from the outlets.

Is the inspection result normal?

YES >> GO TO 8.

NO >> Insufficient cooling: [HAC-229, "Inspection procedure"](#).

## 8. CHECK WITH TEMPERATURE SETTING RAISED

1. Operate the temperature control dial (driver side) and raise the temperature setting to 32°C (90°F) after warming up the engine.
2. Check that the warm air blows from the outlets.

Is the inspection result normal?

YES >> GO TO 9.

NO >> Insufficient heating: [HAC-232, "Inspection procedure"](#).

# INSPECTION AND ADJUSTMENT

< BASIC INSPECTION >

[WITH 7 INCH DISPLAY]

## 9. CHECK LH/RH INDEPENDENT TEMPERATURE ADJUSTMENT FUNCTION

1. Press the DUAL switch, and then check that "DUAL" is shown on the display.
2. Operate the temperature control dial (driver side). Check that the discharge air temperature (driver side) changes.
3. Operate the temperature control dial (passenger side). Check that the discharge air temperature (passenger side) changes.
4. Press the DUAL switch, and then check that the temperature setting (LH/RH) is unified to the driver side temperature setting.

Is the inspection result normal?

YES >> GO TO 10.

NO >> Refer to [HAC-228, "Diagnosis Chart By Symptom"](#) and perform the appropriate diagnosis.

## 10. CHECK AUTO MODE

1. Press the AUTO switch, and then check that "AUTO" is shown on the display.
2. Operate the temperature control dial (driver side). Check that the fan speed or outlet changes (the discharge air temperature or fan speed varies depending on the ambient temperature, in-vehicle temperature, and temperature setting).

Is the inspection result normal?

YES >> INSPECTION END

NO >> Refer to [HAC-228, "Diagnosis Chart By Symptom"](#) and perform the appropriate diagnosis.

## Temperature Setting Trimmer

INFOID:000000005514674

### Description

If the temperature felt by the customer is different than the air flow temperature controlled by the temperature setting, the auto amplifier control temperature can be adjusted to compensate for the temperature setting.

### How to set

Using CONSULT-III, perform "TEMP SET CORRECT" on "WORK SUPPORT" of HVAC.

Work support items	Display (°F)	Display (°C)
TEMP SET CORRECT	6	3.0
	5	2.5
	4	2.0
	3	1.5
	2	1.0
	1	0.5
	0 (initial status)	0 (initial status)
	-1	-0.5
	-2	-1.0
	-3	-1.5
	-4	-2.0
	-5	-2.5
	-6	-3.0

### NOTE:

- When the temperature setting is set to 25.0°C (77°F) and -3.0°C (-6°F), the temperature controlled by auto amp is 25.0°C (77°F) - 3.0°C (6°F) = 22.0°C (71°F) and the temperature becomes lower than the temperature setting.
- When the battery cable is disconnected from the negative terminal or when the battery voltage becomes 10V or less, the setting of the difference between the temperature setting and control temperature may be cancelled.

## Foot Position Setting Trimmer

INFOID:000000005514675

### Description

In the FOOT mode, the air blowing to the DEF can be turned ON/OFF.

# INSPECTION AND ADJUSTMENT

< BASIC INSPECTION >

[WITH 7 INCH DISPLAY]

## How to set

Using CONSULT-III, perform "BLOW SET" on "WORK SUPPORT" of HVAC.

Work support items	Display	DEF door position	
		Auto control	Manual control
BLOW SET	Mode 1	OPEN	CLOSE
	Mode 2 (initial status)	OPEN	OPEN
	Mode 3	CLOSE	OPEN
	Mode 4	CLOSE	CLOSE

**NOTE:**

When the battery cable is disconnected from the negative terminal or when the battery voltage becomes 10V or less, the setting of the discharge air mix ratio in FOOT mode may be cancelled.

## Inlet Port Memory Function (FRE)

INFOID:000000005514676

### Description

- If the ignition switch is turned to the OFF position while the FRE switch is set to ON (fresh air intake), "Perform the memory" or "Do not perform the memory" of the FRE switch ON (fresh air intake) condition can be selected.
- If "Perform the memory" was set, the FRE switch will be ON (fresh air intake) when turning the ignition switch to the ON position again.
- If "Do not perform the memory" was set, the air inlets will be controlled automatically when turning the ignition switch to the ON position again.

### How to set

Using CONSULT-III, perform "FRE MEMORY SET" on "WORK SUPPORT" of HVAC.

Work support items	Display	Setting
FRE MEMORY SET	WITHOUT	Perform the memory of manual FRE
	WITH (initial status)	Do not perform the memory of manual FRE (auto control)

**NOTE:**

When the battery cable is disconnected from the negative terminal or when the battery voltage becomes 10V or less, the setting of the FRE switch memory function may be cancelled.

## Inlet Port Memory Function (REC)

INFOID:000000005514677

### Description

- If the ignition switch is turned to the OFF position while the REC switch is set to ON (recirculation), "Perform the memory" or "Do not perform the memory" of the REC switch ON (recirculation) condition can be selected.
- If "Perform the memory" was set, the REC switch will be ON (recirculation) when turning the ignition switch to the ON position again.
- If "Do not perform the memory" was set, the air inlets will be controlled automatically when turning the ignition switch to the ON position again.

### How to set

Using CONSULT-III, perform "REC MEMORY SET" on "WORK SUPPORT" of HVAC.

Work support items	Display	Setting
REC MEMORY SET	WITHOUT (initial status)	Perform the memory of manual REC
	WITH	Do not perform the memory of manual REC (auto control)

**NOTE:**

When the battery cable is disconnected from the negative terminal or when the battery voltage becomes 10V or less, the setting of the REC switch memory function may be cancelled.

# COMPRESSOR CONTROL FUNCTION

< SYSTEM DESCRIPTION >

[WITH 7 INCH DISPLAY]

## SYSTEM DESCRIPTION

### COMPRESSOR CONTROL FUNCTION

#### Description

INFOID:00000000514678

#### PRINCIPLE OF OPERATION

Compressor is not activated.

Functional circuit diagram

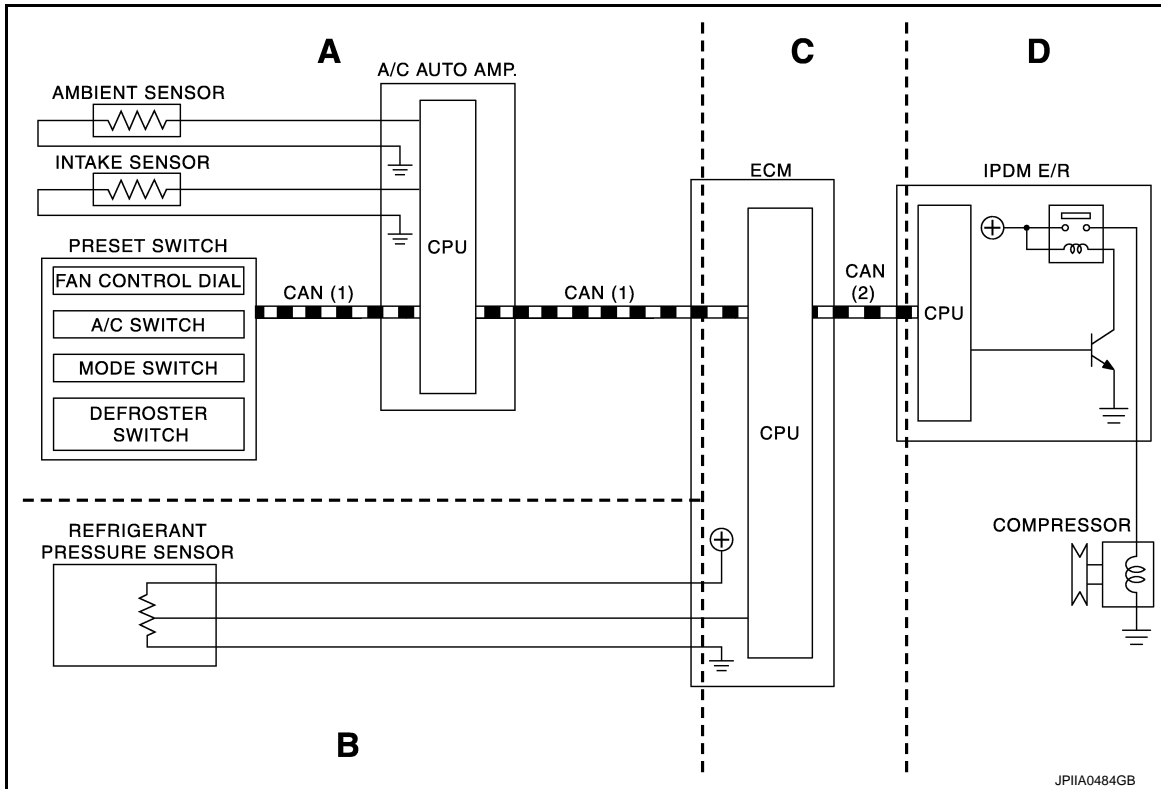

CAN (1) : A/C switch signal  
: Blower fan motor switch signal

CAN (2) : A/C compressor request signal

#### Functional initial inspection chart

x: Applicable

Control unit	Diagnosis item	Location				
		A	B	C	D	
A/C auto amp.	Ⓜ "HVAC"	Self-diagnosis	x	—	—	—
		Data monitor	x	—	—	—
		Active test	x	—	—	x
ECM	Ⓜ "ENGINE"	Self-diagnosis function (CAN system diagnosis)	—	—	x	—
		Data monitor	—	x	x	—
IPDM E/R	Ⓜ "IPDM E/R"	Self-diagnosis function (CAN system diagnosis)	—	—	—	x
		Data monitor	—	—	x	—
		Auto active test	—	—	—	x

# COMPRESSOR CONTROL FUNCTION

< SYSTEM DESCRIPTION >

[WITH 7 INCH DISPLAY]

## Fail-Safe

INFOID:000000005514679

### FAIL-SAFE FUNCTION

- If a communication error exists between the A/C auto amp., and the AV control unit and preset switch for 30 seconds or longer, air conditioner is controlled under the following conditions:

<b>Compressor</b>	<b>: ON</b>
<b>Air outlet</b>	<b>: AUTO</b>
<b>Air inlet</b>	<b>: FRE (Fresh)</b>
<b>Blower fan speed</b>	<b>: AUTO</b>
<b>Set temperature</b>	<b>: Setting before communication error occurs</b>

## Component Part Location

INFOID:000000005514680

### ENGINE COMPARTMENT

# COMPRESSOR CONTROL FUNCTION

< SYSTEM DESCRIPTION >

[WITH 7 INCH DISPLAY]

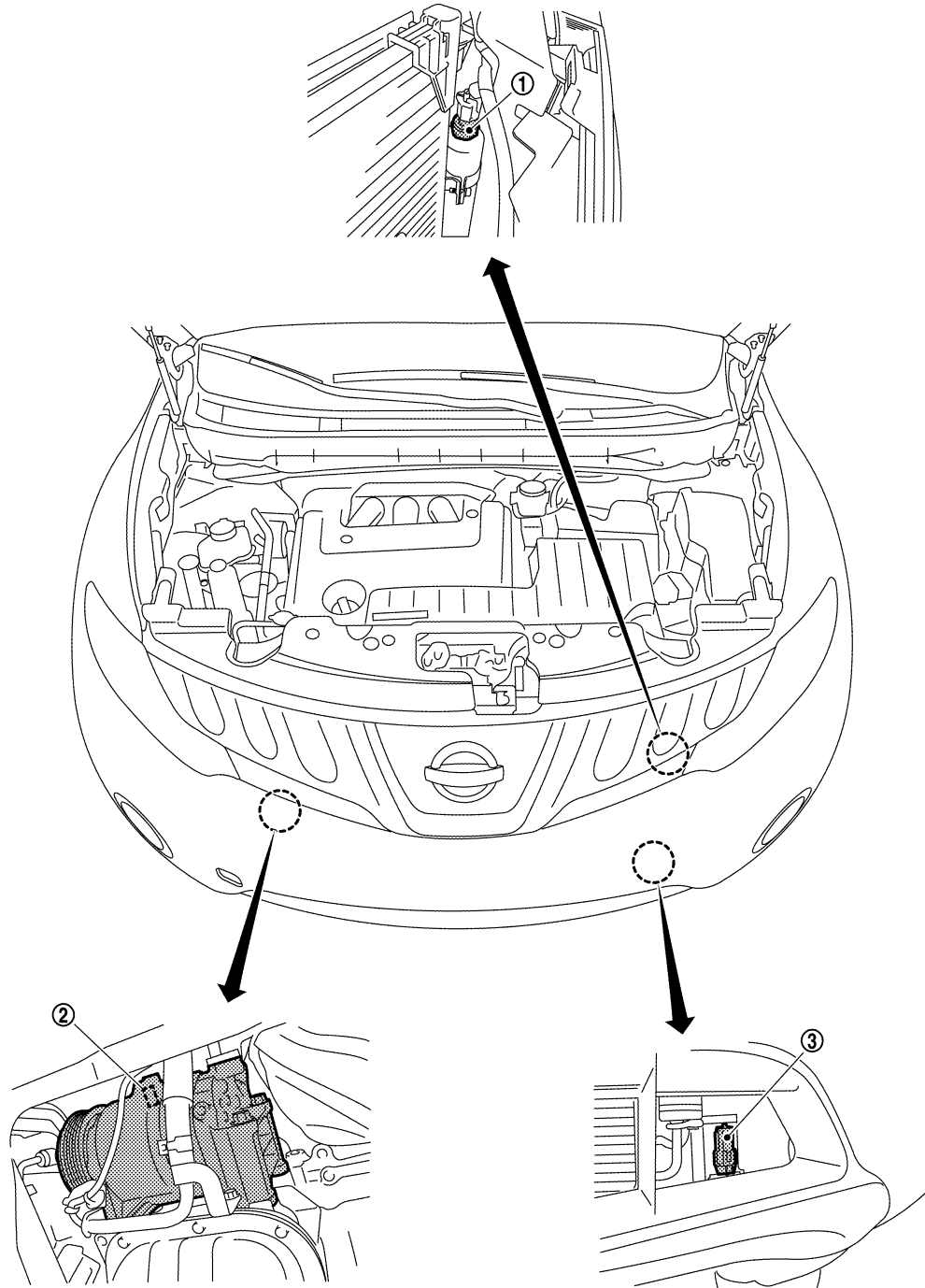

A  
B  
C  
D  
E  
F  
G  
H  
HAC  
J  
K  
L  
M  
N  
O  
P

1. Refrigerant pressure sensor

2. Compressor (magnet clutch)

3. Ambient sensor

PASSENGER COMPARTMENT

JPIIA0607ZZ

# COMPRESSOR CONTROL FUNCTION

< SYSTEM DESCRIPTION >

[WITH 7 INCH DISPLAY]

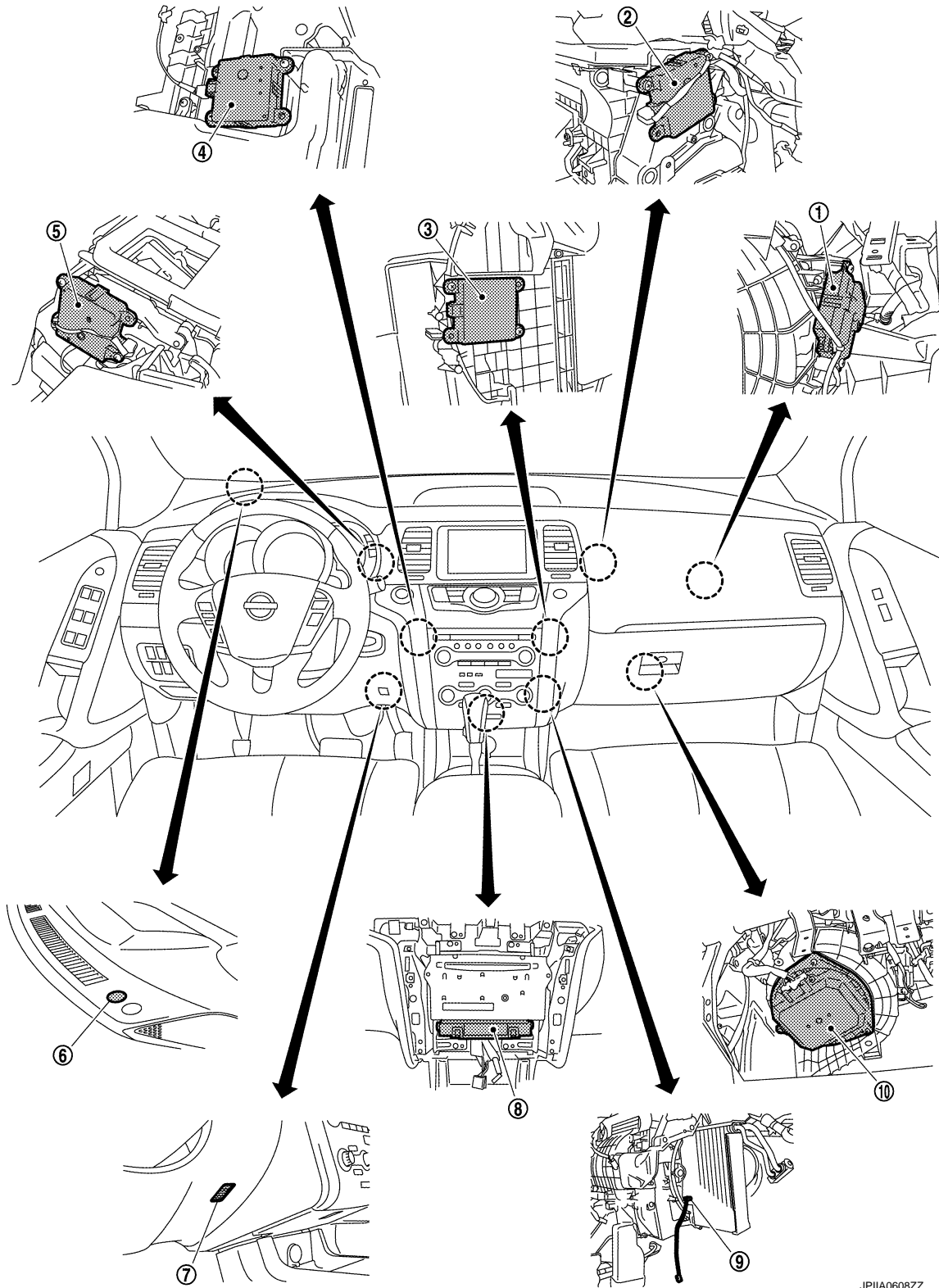

JPIIA0608ZZ

- |                                     |                                |  |
|-------------------------------------|--------------------------------|--|
| 1. Intake door motor                | 2. Upper ventilator door motor | 3. Air mix door motor (passenger side) |
| 4. Air mix door motor (driver side) | 5. Mode door motor             | 6. Sunload sensor                      |
| 7. In-vehicle sensor                | 8. A/C auto amp.               | 9. Intake sensor                       |
| 10. Blower motor                    |                                |  |



# COMPRESSOR CONTROL FUNCTION

< SYSTEM DESCRIPTION >

[WITH 7 INCH DISPLAY]

## Component's Role

INFOID:000000005514681

Component	Reference
Refrigerant pressure sensor	<a href="#">EC-457, "Description"</a>
Compressor	<a href="#">HAC-195, "Description"</a>
Ambient sensor	<a href="#">HAC-167, "Description"</a>
Intake door motor	<a href="#">HAC-186, "Description"</a>
Upper ventilator door motor	<a href="#">HAC-188, "Description"</a>
Air mix door motor (driver side)	<a href="#">HAC-179, "Description"</a>
Air mix door motor (passenger side)	<a href="#">HAC-181, "Description"</a>
Mode door motor	<a href="#">HAC-183, "Description"</a>
Sunload sensor	<a href="#">HAC-176, "Description"</a>
In-vehicle sensor	<a href="#">HAC-170, "Description"</a>
A/C auto amp.	<a href="#">HAC-197, "A/C AUTO AMP. : Description"</a>
Intake sensor	<a href="#">HAC-173, "Description"</a>
Blower motor	<a href="#">HAC-191, "Description"</a>

A  
B  
C  
D  
E  
F  
G  
H  
J  
K  
L  
M  
N  
O  
P

**HAC**

# AUTOMATIC AIR CONDITIONER SYSTEM

< SYSTEM DESCRIPTION >

[WITH 7 INCH DISPLAY]

## AUTOMATIC AIR CONDITIONER SYSTEM

### System Diagram

INFOID:000000005514682

### CONTROL SYSTEM

The control system consists of input sensors, switches, the A/C auto amp. (microcomputer) and outputs. The relationship of these components is as shown in the figure below:

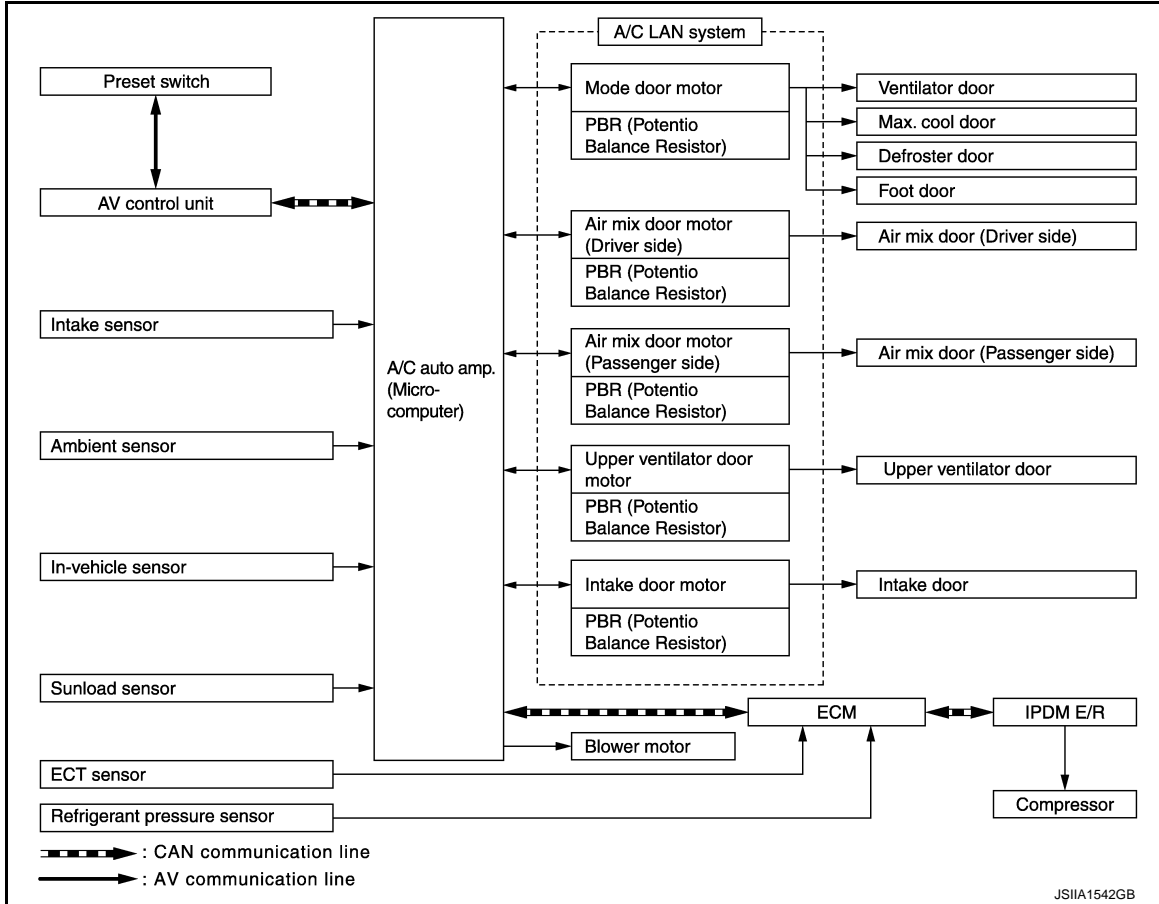

### System Description

INFOID:000000005514683

### CONTROL OPERATION

#### Display

The operation status of the system is displayed on the screen.

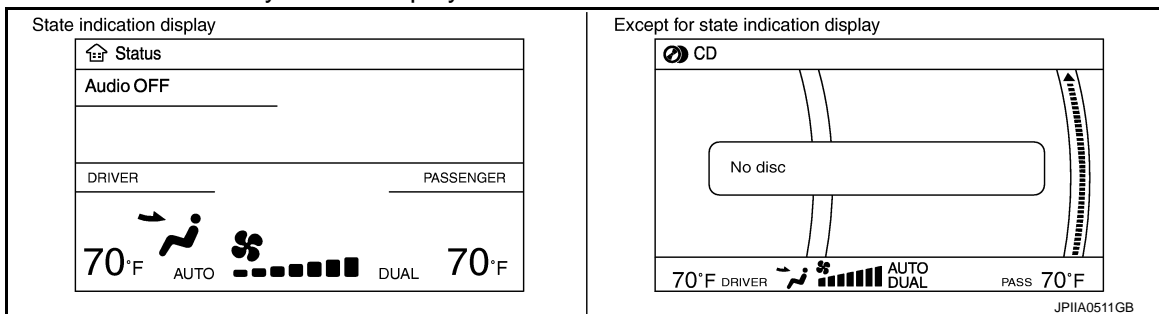

# AUTOMATIC AIR CONDITIONER SYSTEM

< SYSTEM DESCRIPTION >

[WITH 7 INCH DISPLAY]

Preset Switch

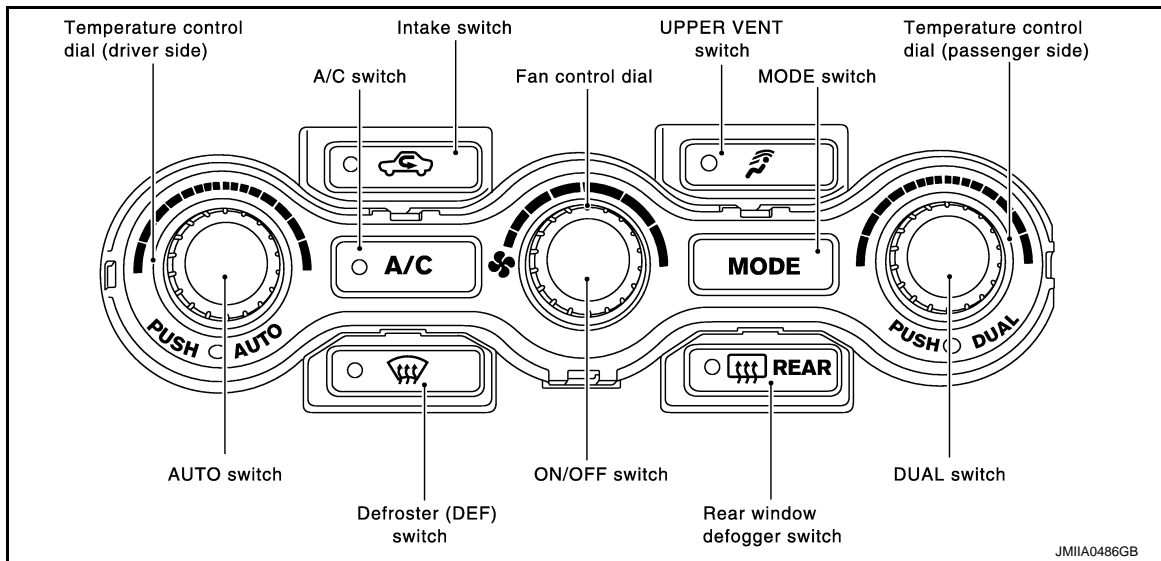

MODE Switch

The air discharge outlets are controlled with this switch.

Temperature Control Dial (Driver Side)

The set temperature is increased or decreased with this dial.

Temperature Control Dial (Passenger Side)

- The set temperature is increased or decreased with this dial.
- When the temperature control dial is turned, DUAL switch indicator is turned ON.

AUTO Switch

- The compressor, intake doors, air mix doors, mode doors and blower speed are automatically controlled so that the in-vehicle temperature will reach, and be maintained at the set temperature selected by the operator.
- When pressing the AUTO switch, air inlet, air outlet, fan speed, and discharge air temperature are automatically controlled.

Defroster (DEF) Switch

Mode doors are set to the defrost position with this switch. Also, intake doors are set to the outside air position, and compressor turns ON.

UPPER VENT Switch

- When the UPPER VENT switch is pressed, the UPPER VENT switch indicator is turned ON.
- When the UPPER VENT switch indicator is turned ON, the UPPER VENT switch indicator is turned OFF by pressing the defroster (DEF) switch (after the above operation, the UPPER VENT switch indicator is turned ON by pressing the UPPER VENT switch).

A/C Switch

Compressor turns ON or OFF with this switch.

(Pressing the A/C switch when the A/C switch is ON turns OFF the A/C switch and compressor.)

Fan Control Dial

The blower speed is manually controlled with this dial. Seven speeds are available for manual control (as shown on the display screen).

ON/OFF Switch

Compressor and blower turn OFF, intake doors and the mode doors are automatically controlled.

Rear Window Defogger Switch

When indicator is ON, rear window is defogged.

Intake Switch

- When the intake switch is ON, the intake switch indicator is turned ON, and air inlet is set to REC.
- When the intake switch is pressed again, the intake switch indicator is turned OFF, and air inlet is set to FRE.
- When the intake switch is pressed for approximately 1.5 seconds or longer, the intake switch indicator lamps blink twice. Then, automatic control mode is entered. Inlet status is displayed by indicator even when automatically controlled.

A  
B  
C  
D  
E  
F  
G  
H  
I  
J  
K  
L  
M  
N  
O  
P

HAC

## **AUTOMATIC AIR CONDITIONER SYSTEM**

< SYSTEM DESCRIPTION >

**[WITH 7 INCH DISPLAY]**

- When the intake switch indicator is turned OFF, shifting mode position to D/F or DEF, or when compressor is turned from ON to OFF, intake switch is automatically turned OFF (set to FRE mode). REC mode can be re-entered by pressing intake switch again, and then compressor is turned ON. (Except D/F or DEF position)

### DUAL Switch

- When the DUAL switch indicator is ON, the driver side and passenger side, temperature can each be set independently.
- When the DUAL switch indicator is OFF, the driver side outlet and setting temperature are applied to both sides.

# AUTOMATIC AIR CONDITIONER SYSTEM

< SYSTEM DESCRIPTION >

[WITH 7 INCH DISPLAY]

## DISCHARGE AIR FLOW

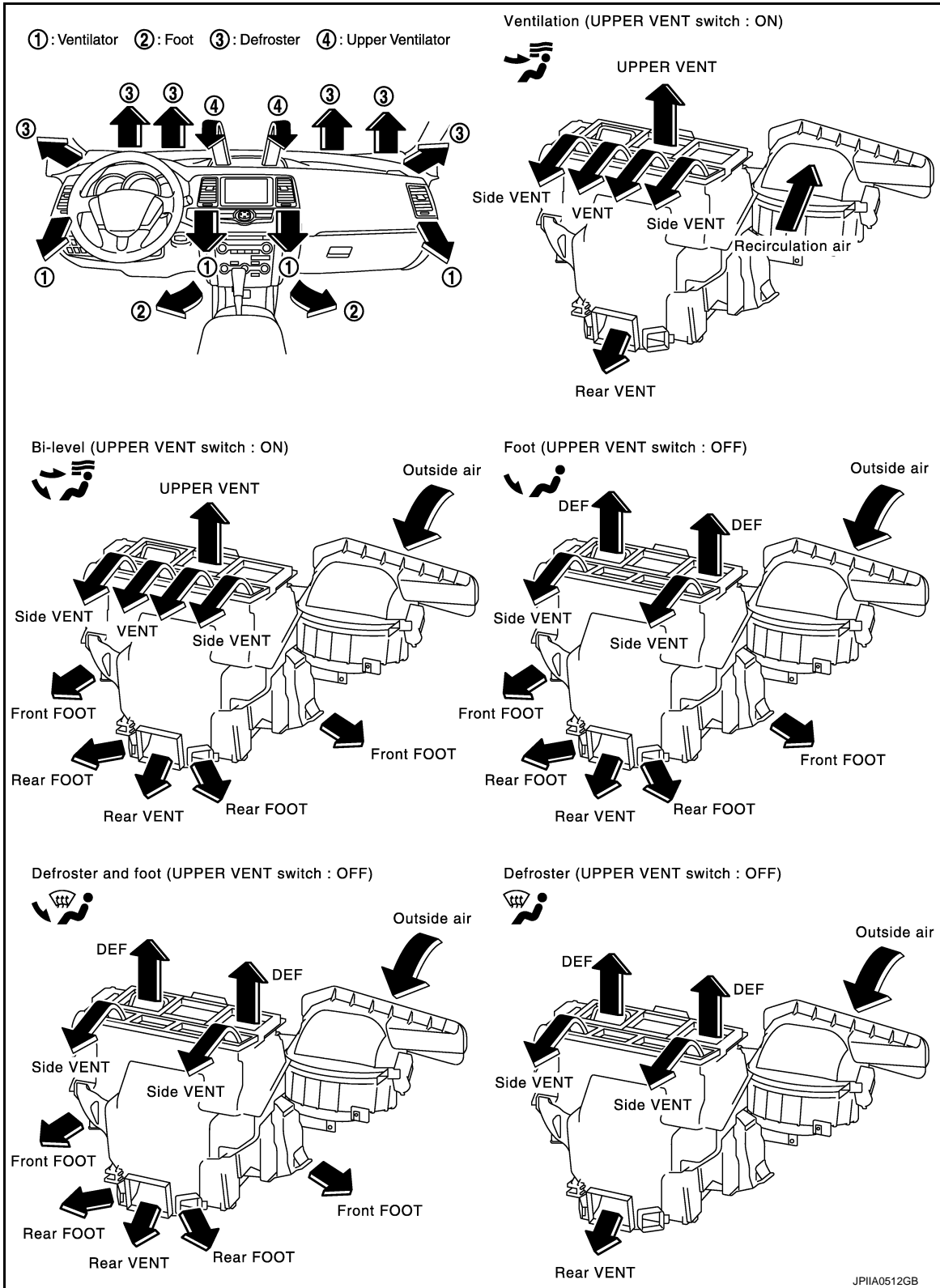

A  
B  
C  
D  
E  
F  
G  
H  
IAC  
J  
K  
L  
M  
N  
O  
P

# AUTOMATIC AIR CONDITIONER SYSTEM

< SYSTEM DESCRIPTION >

[WITH 7 INCH DISPLAY]

## SWITCHES AND THEIR CONTROL FUNCTION

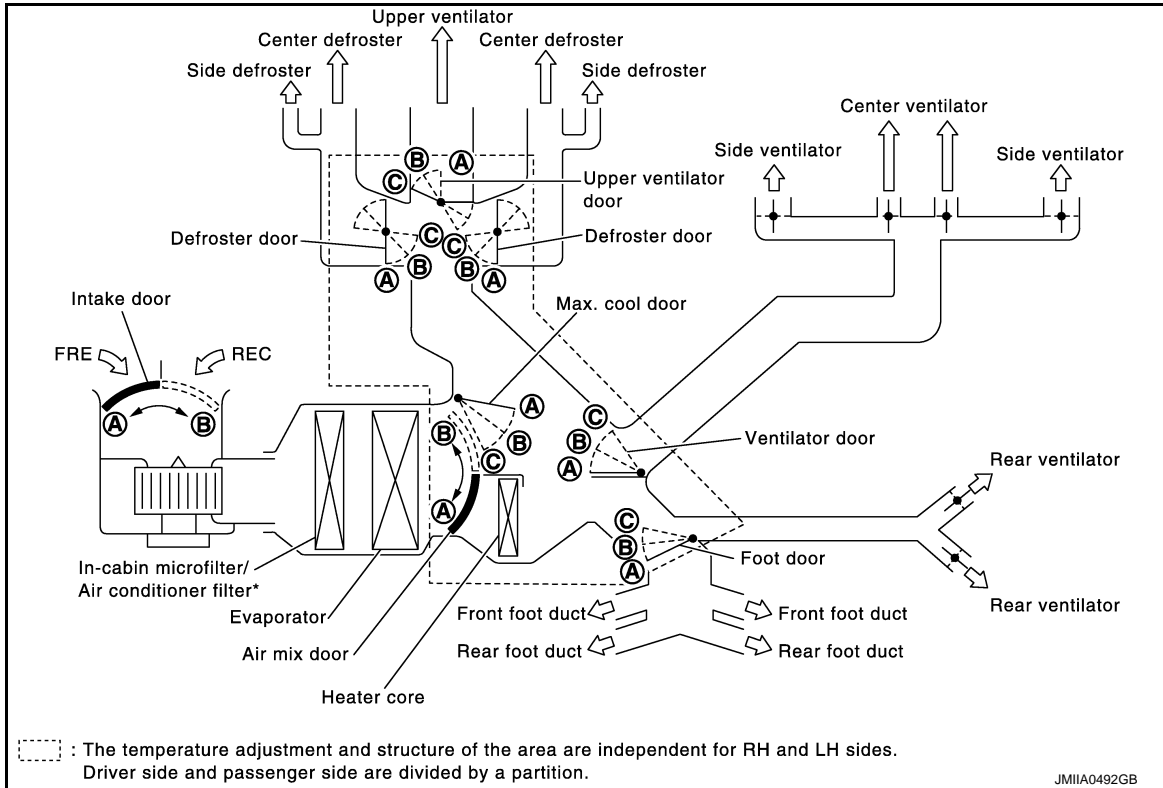

\* : Models for Mexico.

# AUTOMATIC AIR CONDITIONER SYSTEM

< SYSTEM DESCRIPTION >

[WITH 7 INCH DISPLAY]

Switch position			Door position						Air mix door (Driver side)	Air mix door (Passenger side)	
			Ventilator door	Max. cool door	Defroster door	Foot door	Upper ventilator door	Intake door			
AUTO switch	☀		AUTO						AUTO		
MODE switch	VENT	☰	A	A	A	A	—	—			
	B/L	☷	B	B	A	B					
	FOOT	☷	C	B	B	C					
	D/F	☷☰	C	B	B	B					
DEF switch	☷☰	☀	C	C	C	A		B	—	—	
UPPER VENT switch	ON	☷☰☀	—				A-B	—			
	OFF	☷☰○					C				
Intake switch	ON	☷☰☀	—	—	—	—	—	A*			
	OFF	☷☰○						B*			
Temperature control dial (Driver side)	DUAL switch: OFF	18.0°C (60°F)	—	—	—	—	—	—	A		
		18.5°C ⇔ 31.5°C (61°F ⇔ 89°F)							AUTO		
		32.0°C (90°F)							B		
Temperature control dial (Driver side)	DUAL switch: ON	18.0°C (60°F)	—	—	—	—	—	—	A	—	
		18.5°C ⇔ 31.5°C (61°F ⇔ 89°F)							AUTO		
		32.0°C (90°F)							B		
Temperature control dial (Passenger side)	DUAL switch: ON	18.0°C (60°F)	—	—	—	—	—	—	A	—	
		18.5°C ⇔ 31.5°C (61°F ⇔ 89°F)							AUTO		
		32.0°C (90°F)							B		
ON/OFF switch			C	C	B	C	—	B	—	—	

\*: Inlet status is displayed by indicator when activating automatic control.

## AIR CONDITIONER LAN CONTROL SYSTEM

The LAN (Local Area Network) system consists of the A/C auto amp., the mode door motor, the air mix door motors, the upper ventilator door motor and the intake door motor. A configuration of these components is as shown in the figure below.

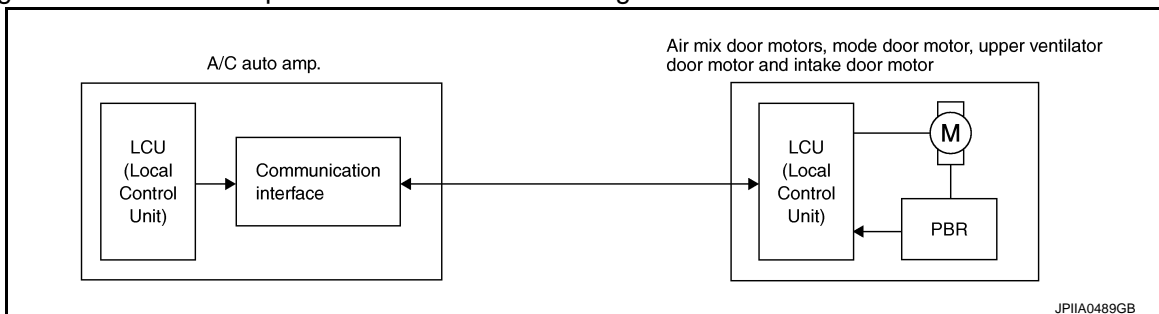

# AUTOMATIC AIR CONDITIONER SYSTEM

< SYSTEM DESCRIPTION >

[WITH 7 INCH DISPLAY]

## SYSTEM CONSTRUCTION

A small network exists between the A/C auto amp., the mode door motor, the air mix door motors, the upper ventilator door motor and the intake door motor. The A/C auto amp. and motors are connected by data transmission lines and motor power supply lines. The LAN network is built through the ground circuits of each door motor.

Addresses, motor opening angle signals, motor stop signals and error checking messages are all transmitted through the data transmission lines connecting the A/C auto amp. and each door motor.

The following functions are contained in LCUs built into the mode door motor, the air mix door motors, the upper ventilator door motor and the intake door motor.

- Address
- Motor opening angle signals
- Data transmission
- Motor stop and drive decision
- Opening angle sensor (PBR function)
- Comparison
- Decision (A/C auto amp. indicated value and motor opening angle comparison)

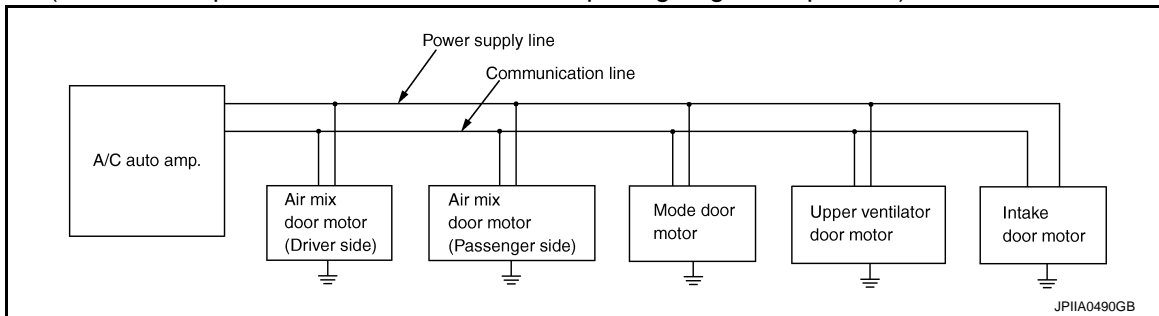

## Operation

The A/C auto amp. receives data from each of the sensors. The A/C auto amp. sends mode door, the air mix door and the intake door opening angle data to the mode door motor LCU, the air mix door motor LCUs, the upper ventilator door motor LCU and the intake door motor LCU.

The mode door motor, the air mix door motors, the upper ventilator door motor and the intake door motor read their respective signals according to the address signal. Opening angle indication signals received from the A/C auto amp. and each of the motor position sensors is compared by the LCUs in each door motor with the existing decision and opening angles. Next, HOT/COLD, DEF/VENT, OPEN/SHUT or FRE/REC operation is selected. The new selection data is returned to the A/C auto amp.

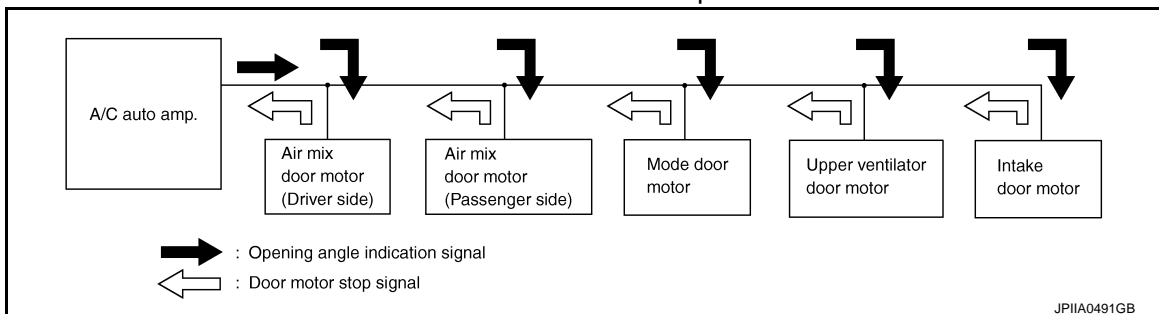

## Transmission Data and Transmission Order

A/C auto amp. data is transmitted consecutively to each of the door motors following the form as shown in the figure below.

### START:

- Initial compulsory signal is sent to each of the door motors.

### ADDRESS:

- Data sent from the A/C auto amp. is selected according to data-based decisions made by the mode door motor, the air mix door motors, the upper ventilator door motor and the intake door motor.
- If the addresses are identical, the opening angle data and error check signals are received by the door motor LCUs. The LCUs then make the appropriate error decision. If the opening angle data has no error, door control begins.
- If an error exists, the received data is rejected and corrected the data received. Finally, door control is based upon the corrected opening angle data.



# AUTOMATIC AIR CONDITIONER SYSTEM

< SYSTEM DESCRIPTION >

[WITH 7 INCH DISPLAY]

**OPENING ANGLE:**

- Data that shows the indicated door opening angle of each door motor.

**ERROR CHECK:**

- In this procedure, transmitted and received data is checked for errors. Error data is then compiled. The error check prevents corrupted data from being used by the mode door motor, the air mix door motors, the upper ventilator door motor and the intake door motor. Error data can be related to the following symptoms.
  - Malfunction of electrical frequency
  - Poor electrical connections
  - Signal leakage from transmission lines
  - Signal level fluctuation

**STOP SIGNAL:**

- At the end of each transmission, a stop operation, in-operation, or internal malfunction message is delivered to the A/C auto amp. This completes one data transmission and control cycle.

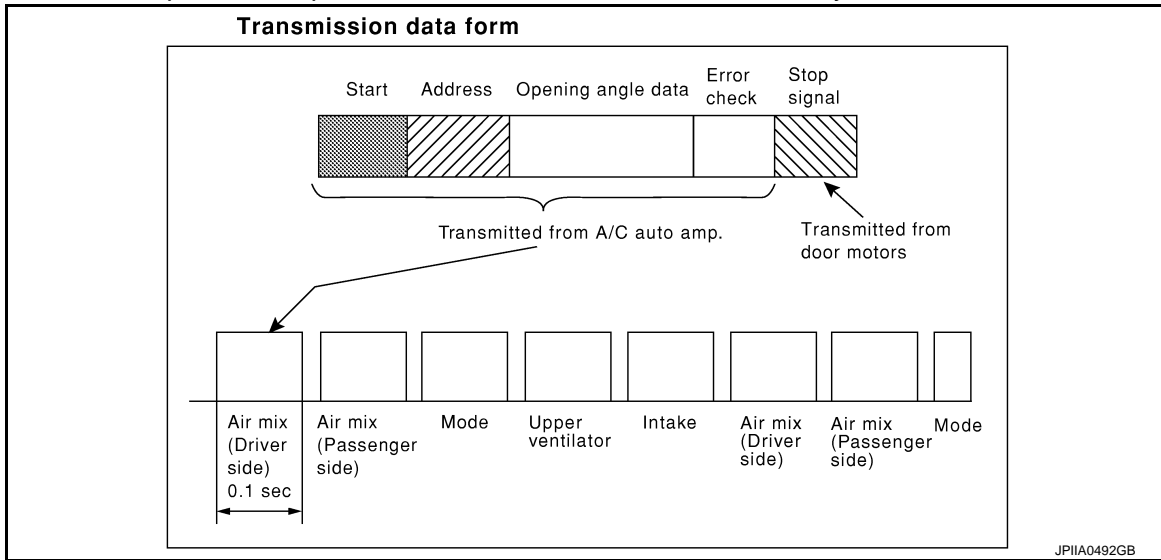

**Component Part Location**

INFOID:000000005514684

**ENGINE COMPARTMENT**

A  
B  
C  
D  
E  
F  
G  
H  
J  
K  
L  
M  
N  
O  
P

HAC

# AUTOMATIC AIR CONDITIONER SYSTEM

< SYSTEM DESCRIPTION >

[WITH 7 INCH DISPLAY]

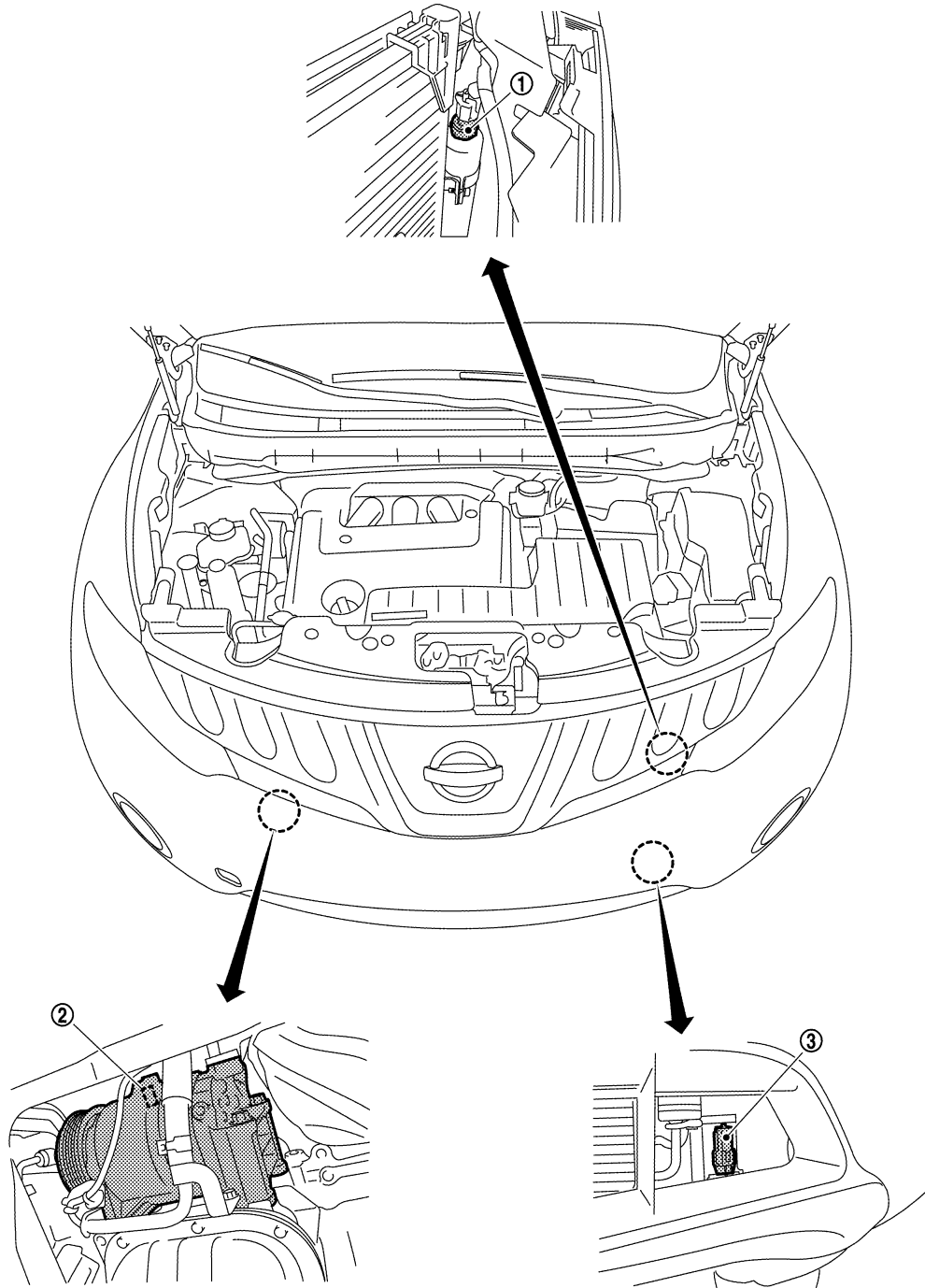

JPIIA0607ZZ

1. Refrigerant pressure sensor

2. Compressor (magnet clutch)

3. Ambient sensor

PASSENGER COMPARTMENT

# AUTOMATIC AIR CONDITIONER SYSTEM

< SYSTEM DESCRIPTION >

[WITH 7 INCH DISPLAY]

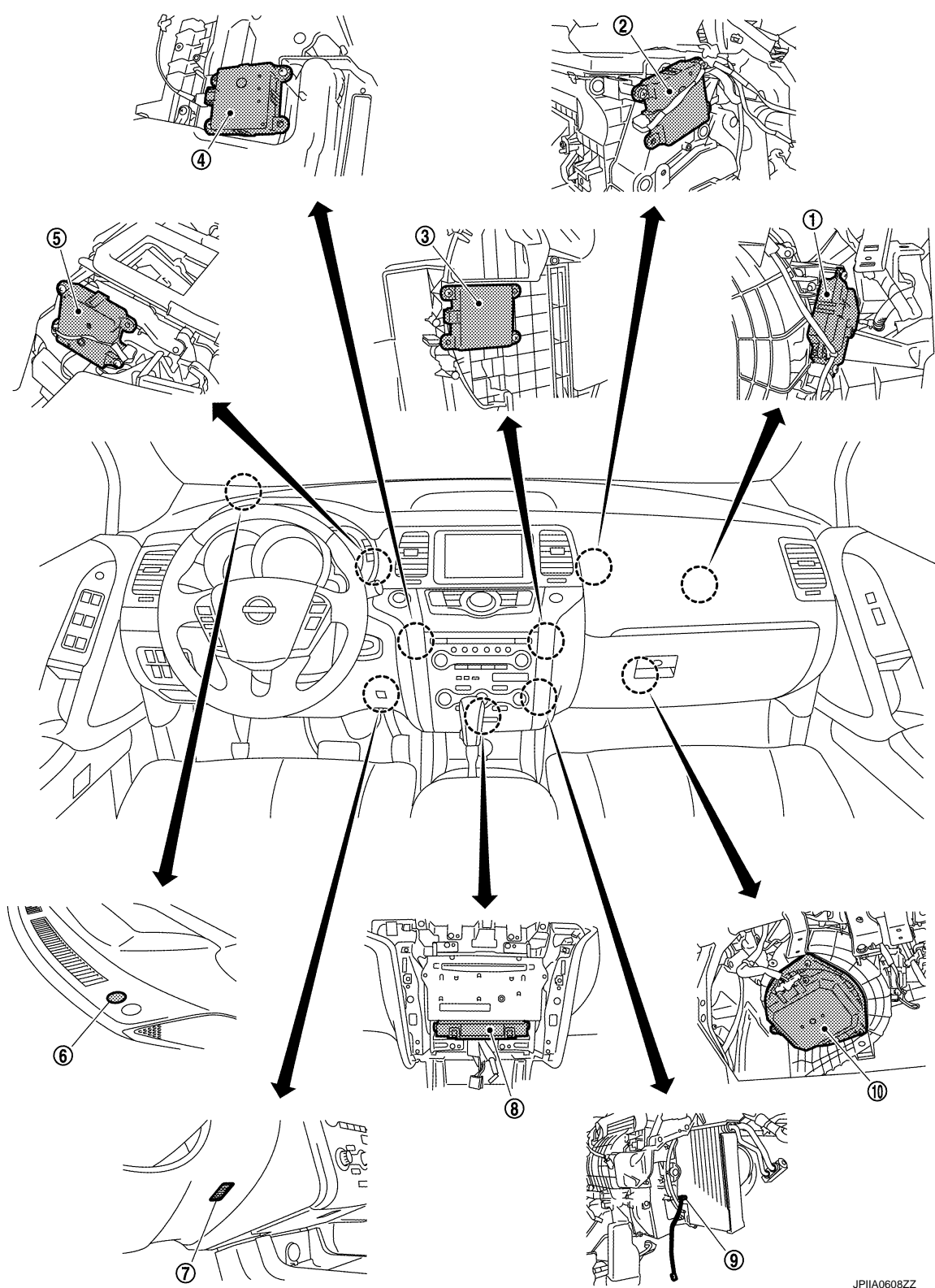

A  
B  
C  
D  
E  
F  
G  
H  
HAC  
J  
K  
L  
M  
N  
O  
P

- |                                     |                                |  |
|-------------------------------------|--------------------------------|--|
| 1. Intake door motor                | 2. Upper ventilator door motor | 3. Air mix door motor (passenger side) |
| 4. Air mix door motor (driver side) | 5. Mode door motor             | 6. Sunload sensor                      |
| 7. In-vehicle sensor                | 8. A/C auto amp.               | 9. Intake sensor                       |
| 10. Blower motor                    |                                |  |

JPIIA0608ZZ

# AUTOMATIC AIR CONDITIONER SYSTEM

< SYSTEM DESCRIPTION >

[WITH 7 INCH DISPLAY]

## Component Description

INFOID:000000005514685

Component	Reference
Refrigerant pressure sensor	<a href="#">EC-457, "Description"</a>
Compressor	<a href="#">HAC-195, "Description"</a>
Ambient sensor	<a href="#">HAC-167, "Description"</a>
Intake door motor	<a href="#">HAC-186, "Description"</a>
Upper ventilator door motor	<a href="#">HAC-188, "Description"</a>
Air mix door motor (driver side)	<a href="#">HAC-179, "Description"</a>
Air mix door motor (passenger side)	<a href="#">HAC-181, "Description"</a>
Mode door motor	<a href="#">HAC-183, "Description"</a>
Sunload sensor	<a href="#">HAC-176, "Description"</a>
In-vehicle sensor	<a href="#">HAC-170, "Description"</a>
A/C auto amp.	<a href="#">HAC-197, "A/C AUTO AMP. : Description"</a>
Intake sensor	<a href="#">HAC-173, "Description"</a>
Blower motor	<a href="#">HAC-191, "Description"</a>

# MODE DOOR CONTROL SYSTEM

< SYSTEM DESCRIPTION >

[WITH 7 INCH DISPLAY]

## MODE DOOR CONTROL SYSTEM

### System Diagram

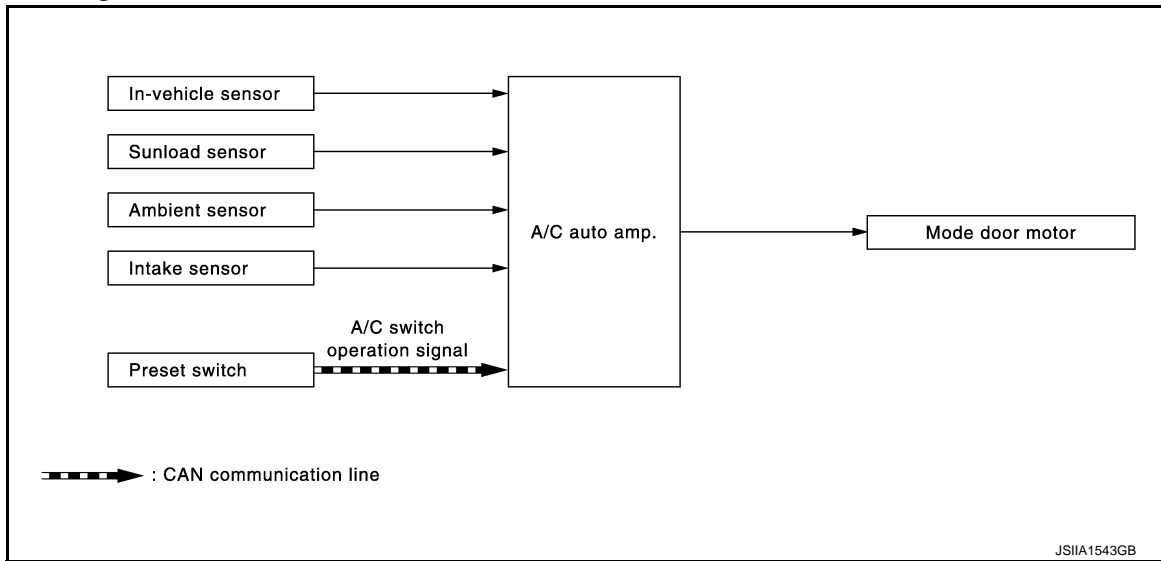

### System Description

INFOID:00000000514687

The mode door is automatically controlled by the temperature setting, ambient temperature, in-vehicle temperature, intake temperature and amount of sunload.

### SYSTEM OPERATION

- The A/C auto amp. receives data from each of the sensors.
- The A/C auto amp. sends the air mix door, the mode door, the upper ventilator door and the intake door opening angle data to the air mix door motor LCU(s), the mode door motor LCU, the upper ventilator door motor LCU and the intake door motor LCU.
- The air mix door motor(s), the mode door motor, the upper ventilator door motor and the intake door motor read their respective signals according to the address signal. Opening angle indication signals received from the A/C auto amp. and each of the motor position sensors are compared by the LCUs in each door motor with the existing decision and opening angles.
- Next, HOT/COLD, DEF/VENT, OPEN/SHUT or FRE/REC operations is selected. The newly selected data is returned to the A/C auto amp.

### Door Motor Circuit

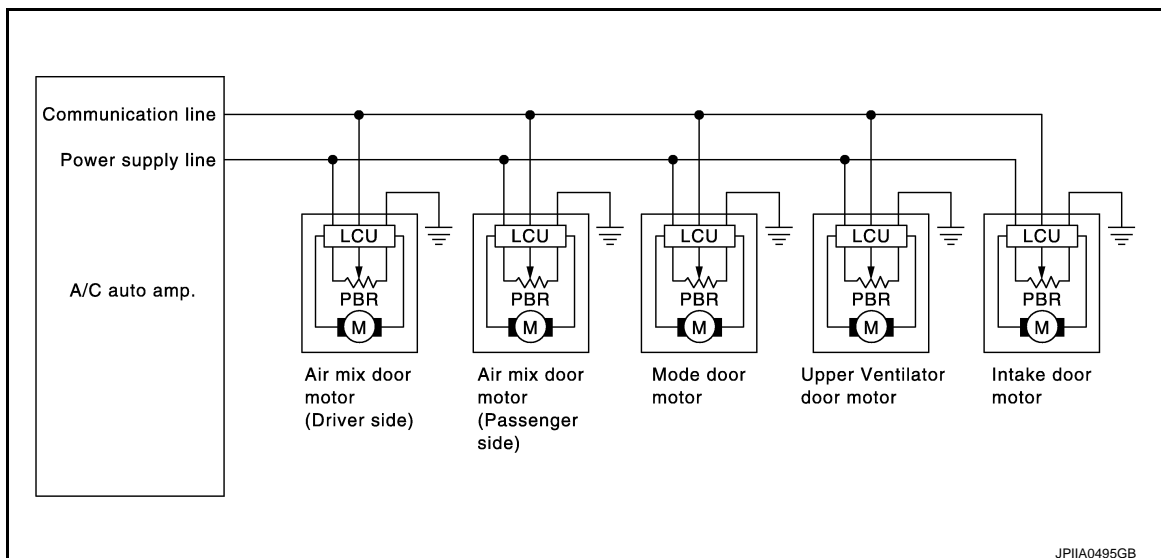

### Mode Door Control Specification

# MODE DOOR CONTROL SYSTEM

[WITH 7 INCH DISPLAY]

## < SYSTEM DESCRIPTION >

Mode position can be selected manually by pressing the MODE switch or the DEF switch on the A/C control. This enables to fix a mode position. Pressing the AUTO switch allows automatic control by the A/C auto amp. During the automatic control of a mode position, a mode door position (VENT, B/L, FOOT, or D/F) is selected based on a target the air mix door opening angle and sunload depending on the temperature calculated by the A/C auto amp. In addition, the D/F is selected to prevent windshield fogging only when ambient temperature is extremely low with mode position the FOOT.

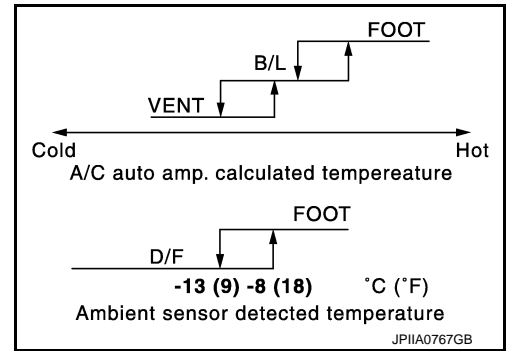

# UPPER VENTILATOR DOOR CONTROL SYSTEM

< SYSTEM DESCRIPTION >

[WITH 7 INCH DISPLAY]

## UPPER VENTILATOR DOOR CONTROL SYSTEM

### System Diagram

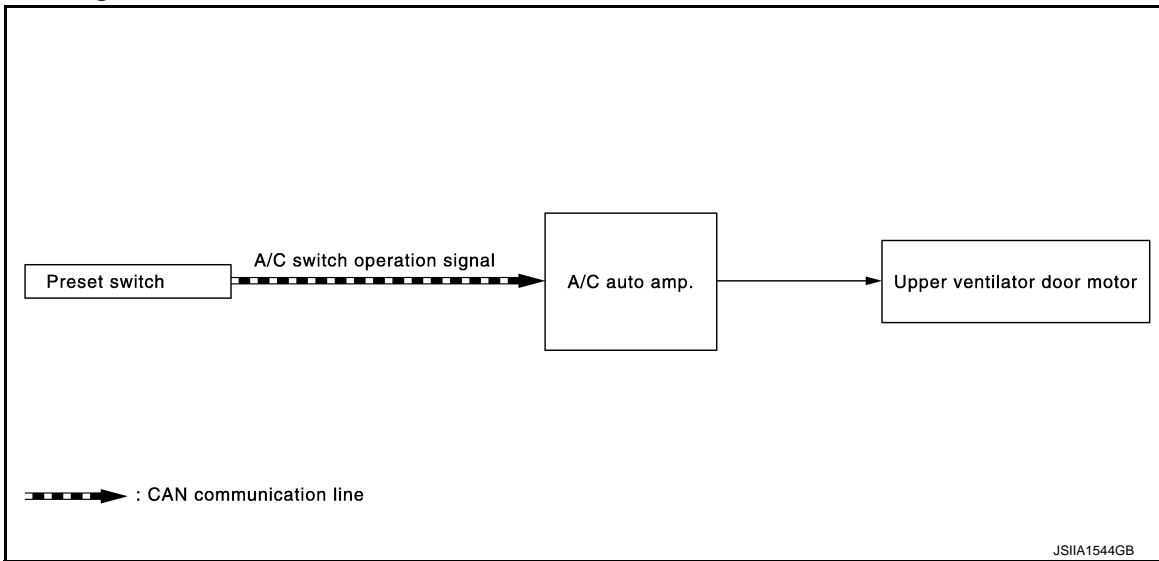

### System Description

INFOID:000000005514689

The upper ventilator door motor is attached to the heater & cooling unit assembly. The upper ventilator door motor operates by the UPPER VENT switch ON/OFF. Motor rotation is conveyed to a rod which activates the upper ventilator door.

### SYSTEM OPERATION

- The A/C auto amp. receives data from each of the sensors.
- The A/C auto amp. sends air mix door, the mode door, the upper ventilator door and the intake door opening angle data to the air mix door motor LCU(s), the mode door motor LCU, the upper ventilator door motor LCU and the intake door motor LCU.
- The air mix door motor(s), the mode door motor, the upper ventilator door motor and the intake door motor read their respective signals according to the address signal. Opening angle indication signals received from the A/C auto amp. and each of the motor position sensors are compared by the LCUs in each door motor with the existing decision and opening angles.
- Next, HOT/COLD, DEF/VENT, OPEN/SHUT or FRE/REC operations is selected. The newly selected data is returned to the A/C auto amp.

### Door Motor Circuit

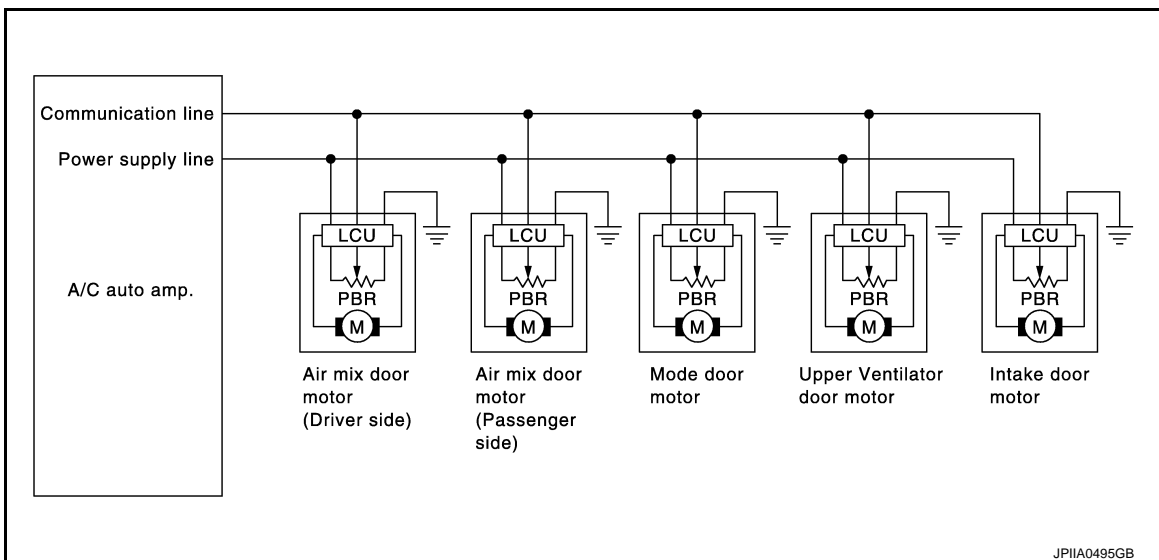

Upper Ventilator Specification

Revision: 2009 September

HAC-151

2010 Murano

# UPPER VENTILATOR DOOR CONTROL SYSTEM

< SYSTEM DESCRIPTION >

[WITH 7 INCH DISPLAY]

UPPER VENT switch	MODE position	Upper ventilator door position
OFF	—	Close
ON	VENT or B/L	Open (Fully-open)
ON	FOOT or D/F	Open (Intermediate)
ON	DEF	Close



# AIR MIX DOOR CONTROL SYSTEM

< SYSTEM DESCRIPTION >

[WITH 7 INCH DISPLAY]

## AIR MIX DOOR CONTROL SYSTEM

### System Diagram

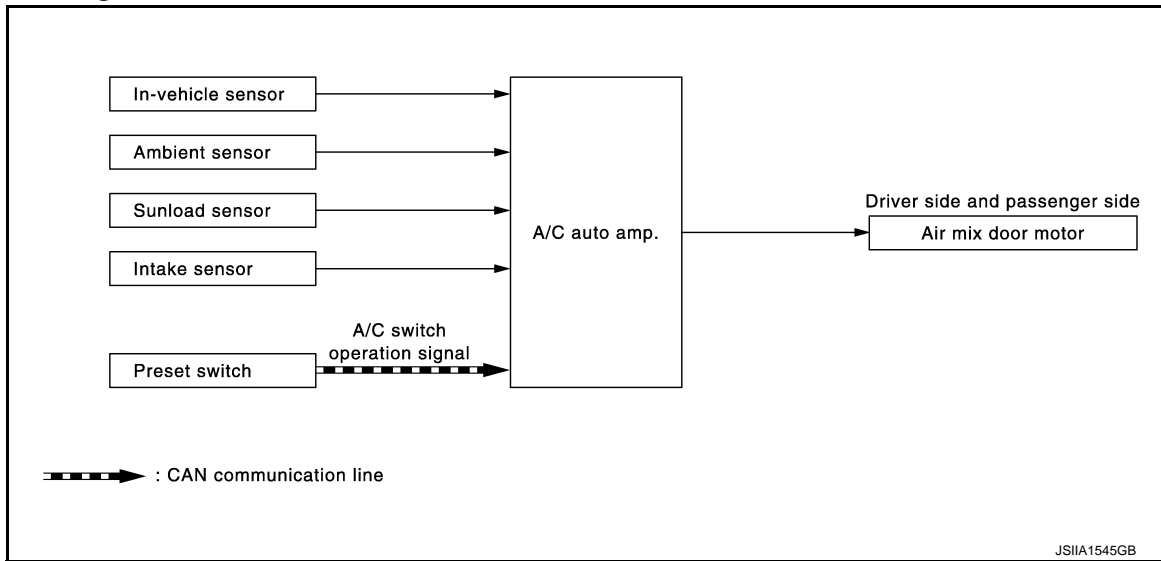

### System Description

INFOID:000000005514691

The air mix doors are automatically controlled so that in-vehicle temperature is maintained at a predetermined value by the temperature setting, ambient temperature, intake temperature and amount of sunload.

### SYSTEM OPERATION

- The A/C auto amp. receives data from each of the sensors.
- The A/C auto amp. sends air mix door, the mode door, the upper ventilator door and the intake door opening angle data to the air mix door motor LCU(s), the mode door motor LCU, the upper ventilator door motor LCU and the intake door motor LCU.
- The air mix door motor(s), the mode door motor, the upper ventilator door motor and the intake door motor read their respective signals according to the address signal. Opening angle indication signals received from the A/C auto amp. and each of the motor position sensors are compared by the LCUs in each door motor with the existing decision and opening angles.
- Next, HOT/COLD, DEF/VENT, OPEN/SHUT or FRE/REC operation is selected. The newly selected data is returned to the A/C auto amp.

### Door Motor Circuit

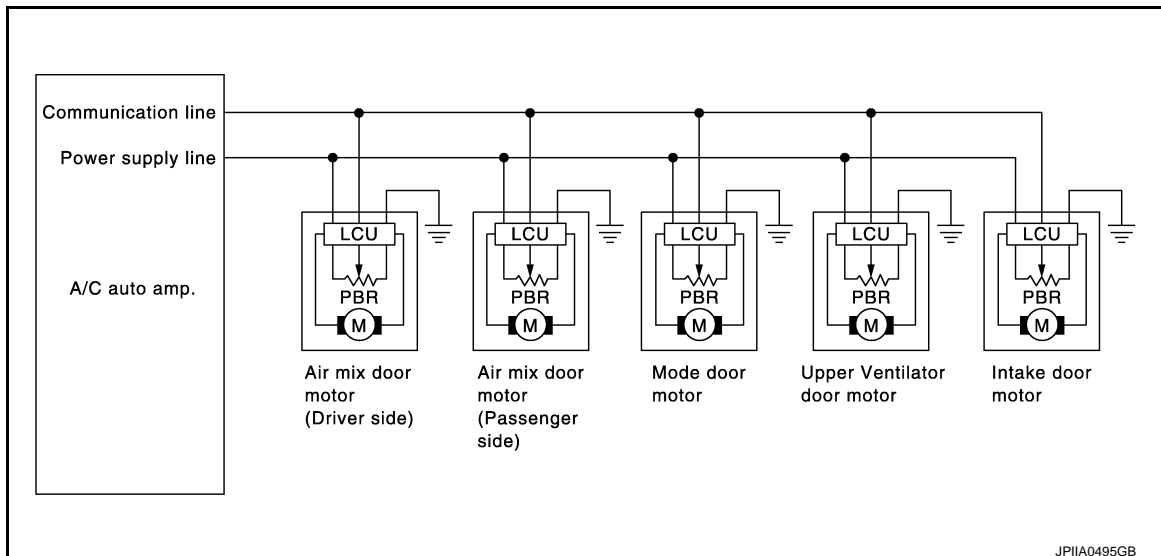

### Air Mix Door Control Specification

A  
B  
C  
D  
E  
F  
G  
H  
HAC  
J  
K  
L  
M  
N  
O  
P

# AIR MIX DOOR CONTROL SYSTEM

[WITH 7 INCH DISPLAY]

## < SYSTEM DESCRIPTION >

When ignition switch is ON, the A/C auto amp. continuously and automatically controls temperatures regardless of air conditioner operational condition. When setting a target temperature with the temperature control switch, the A/C auto amp. corrects the set temperature and decides a target air mix door opening angle. The A/C auto amp. controls air mix door according to the target air mix door opening angle and current air mix door opening angle, keeping an optimum air mix door opening angle. When the temperature is set at 18°C (60°F), air mix door is set on full cold, and when the temperature is set at 32°C (90°F), it is set to full hot.

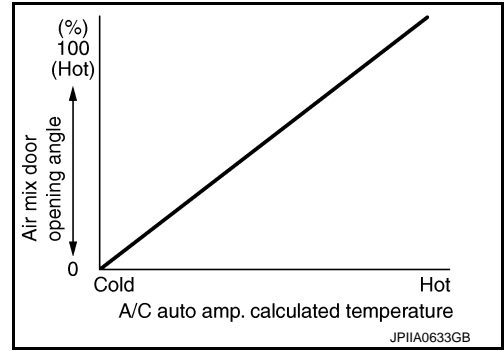

# INTAKE DOOR CONTROL SYSTEM

< SYSTEM DESCRIPTION >

[WITH 7 INCH DISPLAY]

## INTAKE DOOR CONTROL SYSTEM

### System Diagram

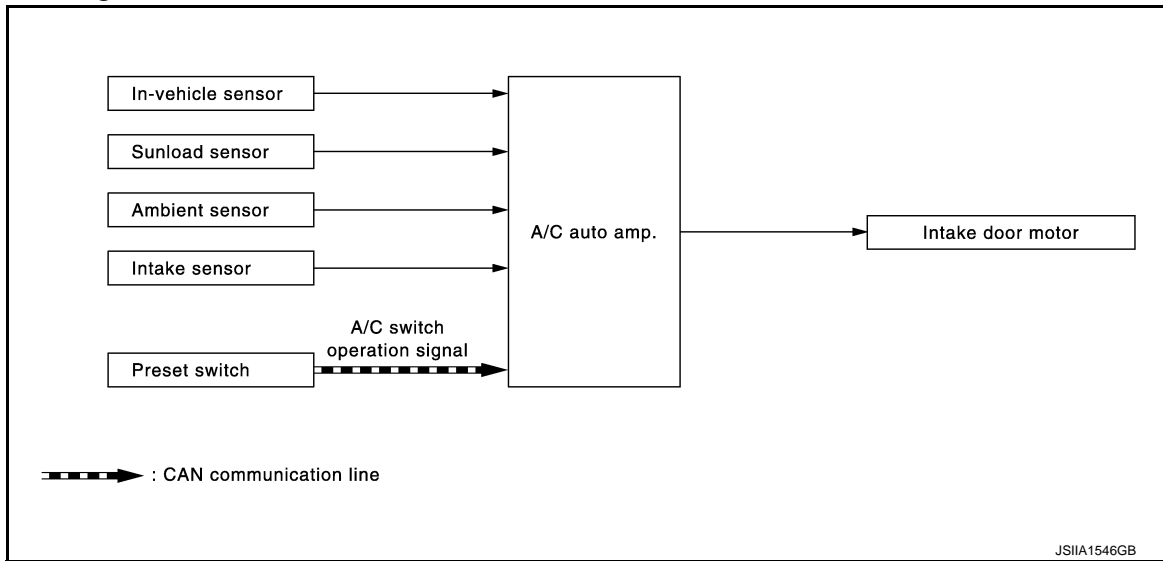

### System Description

INFOID:00000000514693

The intake doors are automatically controlled by the temperature setting, ambient temperature, in-vehicle temperature, intake temperature, amount of sunload and ON/OFF operation of the compressor.

### SYSTEM OPERATION

The intake door control judges intake door position based on the ambient temperature, the intake air temperature and the in-vehicle temperature. When in shifting mode position D/F, if the DEF or ON/OFF switches are pressed, or when the A/C switch is OFF, the A/C auto amp. sets the intake door to the FRE position.

### Door Motor Circuit

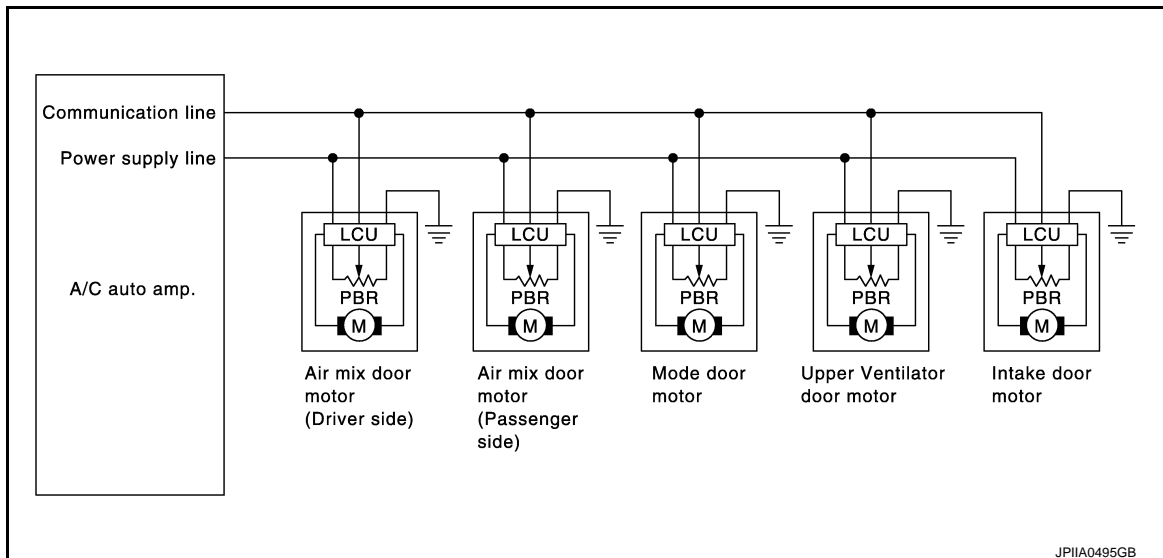

### Intake Door Control Specification

# INTAKE DOOR CONTROL SYSTEM

[WITH 7 INCH DISPLAY]

## < SYSTEM DESCRIPTION >

Intake door position is basically set to the FRE when the FRE indicator of the DEF switch and the intake switch turn ON, and set on the REC when the REC indicator of intake switch turns ON.

The intake door automatic control selects the FRE, the 20%FRE, or the REC depending on the target air mix door opening angle, based on in-vehicle temperature, ambient temperature, and sunload.

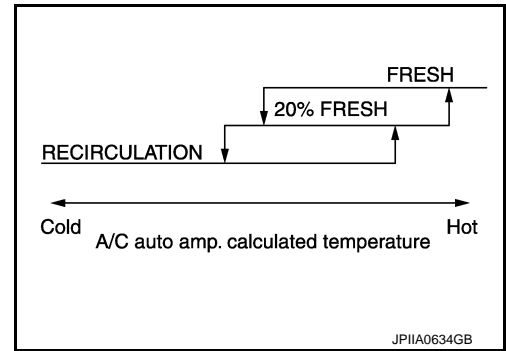

# BLOWER MOTOR CONTROL SYSTEM

< SYSTEM DESCRIPTION >

[WITH 7 INCH DISPLAY]

## BLOWER MOTOR CONTROL SYSTEM

### System Diagram

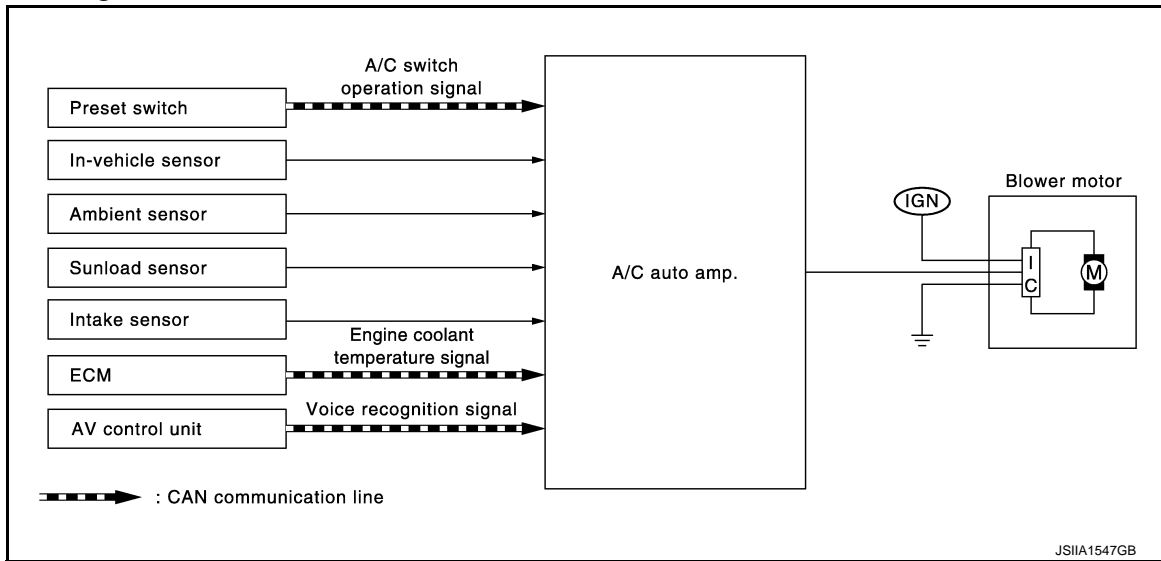

### System Description

INFOID:000000005514695

Blower speed is automatically controlled by the temperature setting, ambient temperature, in-vehicle temperature, intake temperature, amount of sunload and air mix door position.

By pressing the AUTO switch, the blower motor starts to gradually increase air flow volume.

When engine coolant temperature is low, the blower motor operation is delayed to prevent cool air from flowing.

### SYSTEM OPERATION

#### System operation

- For air flow, the manual selection (1-7) with the fan control dial has priority.
- If the AUTO switch is pressed or if the DEF switch is pressed while in the OFF condition, it changes to the automatic control by A/C auto amp.
- When increasing the air flow, it changes the duty ratio of the blower motor drive signal to prevent the air flow from suddenly increasing.
- There are the following types of air flow control: starting air flow control, starting air flow control at low coolant temperature, starting air flow control at high in-vehicle temperature, and air flow control at actuator operation in addition to manual control, normal automatic air flow control.

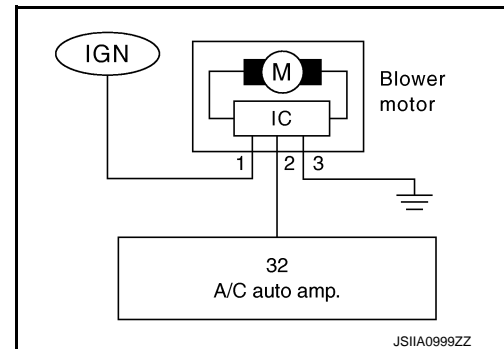

#### Normal automatic air flow control

- When the target temperature is set by the temperature control dial of preset switch, the A/C auto amp. performs the calculation and decides the target according to the signal from each sensor.
- The A/C auto amp. changes the duty ratio of blower motor drive signal and controls the air flow continuously so that the air flow becomes the target air flow.
- The minimum air flow will change according to the sunload when the air discharge outlet is VENT or B/L.

# BLOWER MOTOR CONTROL SYSTEM

< SYSTEM DESCRIPTION >

[WITH 7 INCH DISPLAY]

Fan Speed Control Specification

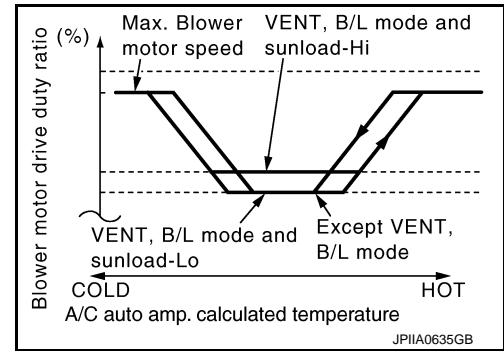

## Starting air flow control

- When starting the automatic control of air flow, the system gradually increases the duty ratio of the blower motor drive signal to prevent too much air from blowing.
- The time period from when the air flow changes from LO to HI is approximately 8 seconds.
- It becomes the starting air flow control at low coolant temperature according to the calculation result of the A/C auto amp. and engine coolant temperature [approximately 58°C (136°F) or less] during the automatic air flow control.
- Do not perform the starting air flow control when the air discharge outlet is set to DEF.

## Starting Fan Speed Control

### Start up from COLD SOAK Condition (Automatic mode)

In cold start up condition where the engine coolant temperature is below 58°C (136°F), the blower does not operate for a short period of time (up to 150 seconds). The exact start delay time varies depending on the ambient temperature and engine coolant temperature.

In the most extreme case (very low ambient temperature) the blower start delay is 150 seconds as described above. After this delay, the blower will operate at low speed until the engine coolant temperature rises above 58°C (136°F), and then the blower speed increases to the objective speed.

### Start up from usual or HOT SOAK Condition (Automatic mode)

The blower will begin operation momentarily after the AUTO switch is pressed. The blower speed rises gradually to the objective speed over a time period of 3 seconds or less (actual time depends on the objective blower speed).

# MAGNET CLUTCH CONTROL SYSTEM

< SYSTEM DESCRIPTION >

[WITH 7 INCH DISPLAY]

## MAGNET CLUTCH CONTROL SYSTEM

### System Diagram

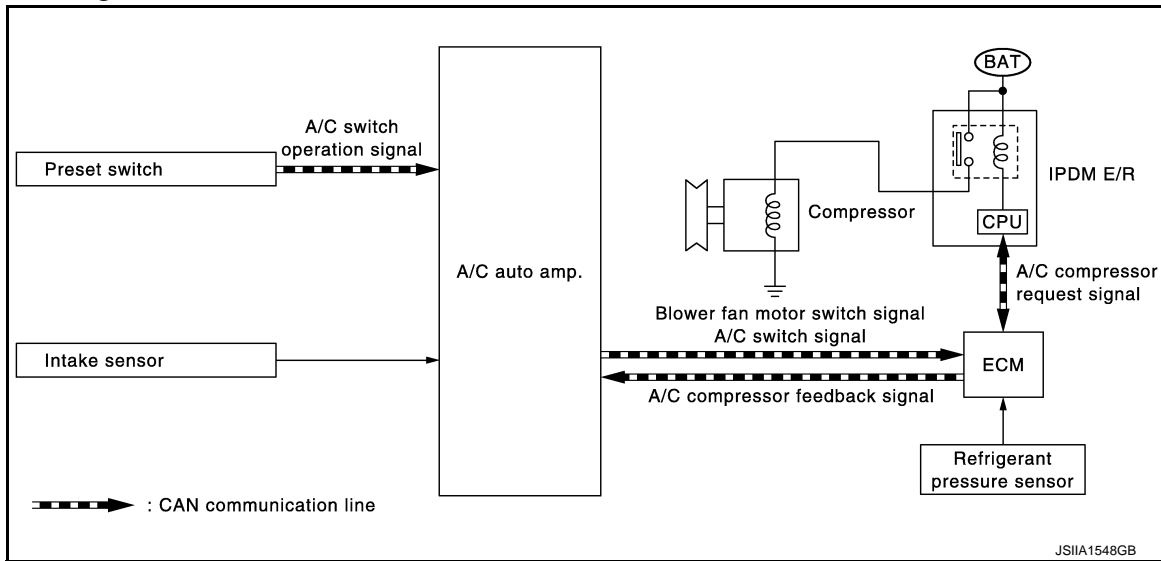

### System Description

INFOID:000000005514697

The A/C auto amp. controls compressor operation by ambient temperature, intake air temperature and signal from ECM.

#### SYSTEM OPERATION

When the A/C switch, the AUTO switch, or the DEF switch is pressed, or when shifting mode position D/F, A/C auto amp. transmit the A/C switch signal and blower fan motor switch signal to the ECM, via CAN communication.

ECM judges whether compressor can be turned ON, based on each sensor status (refrigerant-pressure sensor signal, throttle angle, etc.). If the ECM judges that the compressor can be turned ON, it sends A/C compressor request signal to the IPDM E/R, via CAN communication.

Upon receipt of A/C compressor request signal from the ECM, the IPDM E/R turns the A/C relay ON to operate the compressor.

When sending A/C compressor request signal to the IPDM E/R via CAN communication line, the ECM simultaneously sends A/C compressor feedback signal to A/C auto amp. via CAN communication line.

The ECM sends A/C compressor feedback signal to A/C auto amp., then, uses input A/C compressor feedback signal to control air inlet.

#### Compressor Protection Control

The ECM makes the A/C relay turn OFF and stops the compressor when pressure on the high-pressure side detected by the refrigerant pressure sensor is over approximately 3,119 kPa (31.8 kg/cm<sup>2</sup>, 452 psi), or below approximately 118 kPa (1.2 kg/cm<sup>2</sup>, 17 psi).

#### Low Temperature Protection Control

Turn the A/C relay to OFF and stop the compressor by the signal from the A/C auto amp according to the evaporator passing air temperature detected by the intake sensor and the ambient temperature detected by the ambient sensor.

## CAN COMMUNICATION SYSTEM

---

### System Description

INFOID:000000005514698

CAN (Controller Area Network) is a serial communication line for real time application. It is an on-vehicle multiplex communication line with high data communication speed and excellent error detection ability. Many electronic control units are equipped onto each vehicle, and each control unit shares information and links with other control units during operation (not independent). In CAN communication, control units are connected with 2 communication lines (CAN-H line, CAN-L line) allowing a high rate of information transmission with less wiring. Each control unit transmits/receives data but selectively reads required data only. For details, refer to [LAN-27. "CAN System Specification Chart"](#).



# DIAGNOSIS SYSTEM (HVAC)

< SYSTEM DESCRIPTION >

[WITH 7 INCH DISPLAY]

## DIAGNOSIS SYSTEM (HVAC)

### CONSULT-III Function

INFOID:00000000514699

CONSULT-III can display each diagnosis item using the diagnosis test modes shown as per the following.

#### CONSULT-III application items

Diagnosis mode	Description
ECU Identification	Displays the A/C auto amp. number.
Self Diagnostic Result	Displays the diagnosis results judged by A/C auto amp.
Data Monitor	Displays A/C auto amp. input/output data in real time.
Active Test	The signals used to activate each device are forcibly supplied from A/C auto amp.
Work Support	Changes the setting for each system function. <ul style="list-style-type: none"> <li>• Temperature setting trimmer</li> <li>• Inlet port memory function (FRE)</li> <li>• Inlet port memory function (REC)</li> <li>• Foot position setting trimmer</li> </ul>

### SELF DIAGNOSTIC RESULT

Refer to [HAC-226, "DTC Index"](#).

#### Display Item List

DTC	Items (CONSULT-III screen terms)	Diagnostic item is detected when...	Possible cause
U1000	CAN COMM CIRCUIT	When A/C auto amp. is not transmitting or receiving CAN communication signal for 2 or more seconds.	CAN communication system
U1010	CONTROL UNIT (CAN)	When detecting error during the initial diagnosis of CAN controller of A/C auto amp.	A/C auto amp.
B257B	AMB TEMP SEN SHORT	Detected temperature at ambient sensor $-44^{\circ}\text{C}$ ( $-47^{\circ}\text{F}$ ) or less	<ul style="list-style-type: none"> <li>• Ambient sensor</li> <li>• A/C auto amp.</li> <li>• Harness and connector</li> </ul>
B257C	AMB TEMP SEN OPEN	Detected temperature at ambient sensor $100^{\circ}\text{C}$ ( $212^{\circ}\text{F}$ ) or more	(Ambient sensor circuit is open, or there is a short in the circuit)
B2578	IN CAR SEN SHORT	Detected temperature at in-vehicle sensor $-44^{\circ}\text{C}$ ( $-47^{\circ}\text{F}$ ) or less	<ul style="list-style-type: none"> <li>• In-vehicle sensor</li> <li>• A/C auto amp.</li> <li>• Harness and connector</li> </ul>
B2579	IN CAR SEN OPEN	Detected temperature at in-vehicle sensor $100^{\circ}\text{C}$ ( $212^{\circ}\text{F}$ ) or more	(In-vehicle sensor circuit is open, or there is a short in the circuit)
B2581	EVAP TEMP SEN SHORT	Detected temperature at intake sensor $-33^{\circ}\text{C}$ ( $-27^{\circ}\text{F}$ ) or less	<ul style="list-style-type: none"> <li>• Intake sensor</li> <li>• A/C auto amp.</li> <li>• Harness and connector</li> </ul>
B2582	EVAP TEMP SEN OPEN	Detected temperature at intake sensor $69^{\circ}\text{C}$ ( $156^{\circ}\text{F}$ ) or more	(Intake sensor circuit is open, or there is a short in the circuit)
B2630*	SUNLOAD SEN SHORT	Detected calorie at sunload sensor $64.7 \text{ w/m}^2$ ( $56 \text{ kcal/m}^2\cdot\text{h}$ ) or less	<ul style="list-style-type: none"> <li>• Sunload sensor</li> <li>• A/C auto amp.</li> <li>• Harness and connector</li> </ul>
B2631*	SUNLOAD SEN OPEN	Detected calorie at sunload sensor $2832 \text{ w/m}^2$ ( $2436 \text{ kcal/m}^2\cdot\text{h}$ ) or more	(Sunload sensor circuit is open, or there is a short in the circuit)
B2632	DR AIRMIX ACTR SHORT	Air mix door PBR (driver side) position 5% or less	<ul style="list-style-type: none"> <li>• Air mix door motor (driver side)</li> <li>• A/C auto amp.</li> <li>• Harness and connector</li> </ul>
B2633	DR AIRMIX ACTR OPEN	Air mix door PBR (driver side) position 95% or more	(CAN communication line is open or shorted) (Air mix door motor is open or shorted)

# DIAGNOSIS SYSTEM (HVAC)

< SYSTEM DESCRIPTION >

[WITH 7 INCH DISPLAY]

DTC	Items (CONSULT-III screen terms)	Diagnostic item is detected when...	Possible cause
B2634	PASS AIRMIX ACTR SHORT	Air mix door PBR (passenger side) position 5% or less	<ul style="list-style-type: none"> <li>Air mix door motor (passenger side)</li> <li>A/C auto amp.</li> <li>Harness and connector (CAN communication line is open or shorted)</li> <li>(Air mix door motor is open or shorted)</li> </ul>
B2635	PASS AIRMIX ACTR OPEN	Air mix door PBR (passenger side) position 95% or more	<ul style="list-style-type: none"> <li>Mode door motor</li> <li>A/C auto amp.</li> <li>Harness and connector (CAN communication line is open or shorted)</li> <li>(Mode door motor is open or shorted)</li> </ul>
B2636	DR VENT DOOR FAIL	When the malfunctioning door position is detected at VENT position	<ul style="list-style-type: none"> <li>Mode door motor</li> <li>A/C auto amp.</li> <li>Harness and connector (CAN communication line is open or shorted)</li> <li>(Mode door motor is open or shorted)</li> </ul>
B2637	DR B/L DOOR FAIL	When the malfunctioning door position is detected at B/L position	
B2638	DR D/F1 DOOR FAIL	When the malfunctioning door position is detected at FOOT position	
B2639	DR DEF DOOR FAIL	When the malfunctioning door position is detected at DEF position	
B263D	FRE DOOR FAIL	When the malfunctioning intake door position is detected at FRE position	<ul style="list-style-type: none"> <li>Intake door motor</li> <li>A/C auto amp.</li> <li>Harness and connector (CAN communication line is open or shorted)</li> <li>(Intake door motor is open or shorted)</li> </ul>
B263E	20P FRE DOOR FAIL	When the malfunctioning intake door position is detected at 20%FRE position	
B263F	REC DOOR FAIL	When the malfunctioning intake door position is detected at REC position	
B2654	D/F2 DOOR FAIL	When the malfunctioning door position is detected at D/F position	<ul style="list-style-type: none"> <li>Mode door motor</li> <li>A/C auto amp.</li> <li>Harness and connector (CAN communication line is open or shorted)</li> <li>(Mode door motor is open or shorted)</li> </ul>
B2655	B/L2 DOOR FAIL	When the malfunctioning door position is detected at B/L2 position	
B2661	UPPER VENT DOOR OPEN POSI FAIL	When the malfunctioning upper ventilator door position is detected at open position.	<ul style="list-style-type: none"> <li>Upper ventilator door motor</li> <li>A/C auto amp.</li> <li>Harness and connector (CAN communication line is open or shorted)</li> <li>(Upper ventilator door motor is open or shorted)</li> </ul>
B2662	UPPER VENT DOOR MID POSI FAIL	When the malfunctioning upper ventilator door position is detected at middle position.	
B2663	UPPER VENT DOOR SHUT POSI FAIL	When the malfunctioning upper ventilator door position is detected at shut position.	

\*: Perform self-diagnosis under sunshine. When performing indoors, aim a light (more than 60 W) at sunload sensor, otherwise self-diagnosis indicates even though the sunload sensor is functioning normally.

## DATA MONITOR

Display item list

Monitor item [Unit]	Description
COMP REQ SIG [On/Off]	Displays A/C switch ON/OFF status transmitted to other units via CAN communication
FAN REQ SIG [On/Off]	Displays blower switch ON/OFF status transmitted to other units via CAN communication
AMB TEMP SEN [°C]	Ambient sensor value converted from ambient sensor signal received from ambient sensor
IN-VEH TEMP [°C]	In-vehicle sensor value converted from in-vehicle sensor signal received from in-vehicle sensor
INT TEMP SEN [°C]	Intake sensor value converted from intake sensor signal received from intake sensor
SUNLOAD SEN [w/m <sup>2</sup> ]	Sunload sensor value converted from sunload sensor signal received from sunload sensor

# DIAGNOSIS SYSTEM (HVAC)

< SYSTEM DESCRIPTION >

[WITH 7 INCH DISPLAY]

Monitor item [Unit]	Description
AMB SEN CAL [°C]	Ambient sensor value calculated by A/C auto amp.
IN-VEH CAL [°C]	In-vehicle sensor value calculated by A/C auto amp.
INT TEMP CAL [°C]	Intake sensor value calculated by A/C auto amp.
SUNL SEN CAL [w/m <sup>2</sup> ]	Sunload sensor value calculated by A/C auto amp.
FAN DUTY	Duty ratio of blower motor judged by A/C auto amp.
XM	Target discharge air temperature judged by A/C auto amp. according to the temperature setting and the value from each sensor
ENG COOL TEMP [°C]	Water temperature signal value received from ECM via CAN communication
VEHICLE SPEED [Mph (km/h)]	Vehicle speed signal value received from meter via CAN communication

## ACTIVE TEST

Test item	Description
ALL SEG	<b>NOTE:</b> <ul style="list-style-type: none"> <li>Item can be displayed but cannot be tested.</li> <li>When choosing to turn "ALL SEG" on, error message is displayed but it is not malfunction.</li> </ul>
HVAC TEST	The operation check of A/C system can be performed by selecting the mode. Refer to the following table for the conditions of each mode.

## HVAC TEST

	Test item						
	MODE 1	MODE 2	MODE 3	MODE 4	MODE 5	MODE 6	MODE 7
Mode door position	VENT1	VENT2	B/L1	B/L2	FOOT	D/F	DEF
Intake door position	REC	REC	20%FRE	20%FRE	FRE	FRE	FRE
Air mix door position (driver & passenger side)	FULL COLD	FULL HOT	FULL COLD	FULL HOT	FULL HOT	FULL HOT	FULL HOT
Blower motor duty ratio	35%	35%	61%	61%	81%	81%	35%
Compressor (Magnet clutch)	ON	ON	ON	ON	OFF	OFF	ON
Upper ventilator door	OPEN	SHUT	OPEN	SHUT	SHUT	SHUT	SHUT

### NOTE:

Perform the inspection of each output device after starting the engine because the compressor is operated.

## WORK SUPPORT

Work item	Description	Reference
TEMP SET CORRECT (Setting of difference between temperature setting and control temperature)	If the temperature felt by the customer is different than the air flow temperature controlled by the temperature setting, the auto amplifier control temperature can be adjusted to compensate for the temperature setting.	<a href="#">HAC-131. "Temperature Setting Trimmer"</a>
BLOW SET (Blow setting to DEF in FOOT mode)	In the FOOT mode, the air blowing to the DEF can change ON/OFF.	<a href="#">HAC-131. "Foot Position Setting Trimmer"</a>

# DIAGNOSIS SYSTEM (HVAC)

< SYSTEM DESCRIPTION >

[WITH 7 INCH DISPLAY]

Work item	Description	Reference
FRE MEMORY SET (FRE memory function setting)	<ul style="list-style-type: none"><li>• If the ignition switch is turned to the OFF position while the FRE switch is set to ON (fresh air intake), "Perform the memory" or "Do not perform the memory" of the FRE switch ON (fresh air intake) condition can be selected.</li><li>• If "Perform the memory" was set, the FRE switch will be ON (fresh air intake) when turning the ignition switch to the ON position again.</li><li>• If "Do not perform the memory" was set, the air inlets will be controlled automatically when turning the ignition switch to the ON position again.</li></ul>	<a href="#">HAC-132. "Inlet Port Memory Function (FRE)"</a>
REC MEMORY SET (REC memory function setting)	<ul style="list-style-type: none"><li>• If the ignition switch is turned to the OFF position while the REC switch is set to ON (recirculation), "Perform the memory" or "Do not perform the memory" of the REC switch ON (recirculation) condition can be selected.</li><li>• If "Perform the memory" was set, the REC switch will be ON (recirculation) when turning the ignition switch to the ON position again.</li><li>• If "Do not perform the memory" was set, the air inlets will be controlled automatically when turning the ignition switch to the ON position again.</li></ul>	<a href="#">HAC-132. "Inlet Port Memory Function (REC)"</a>

**NOTE:**

When the battery cable is disconnected from the negative terminal or when the battery voltage becomes 10 V or less, the setting of WORK SUPPORT may be cancelled.

**DTC/CIRCUIT DIAGNOSIS**

**U1000 CAN COMM CIRCUIT**

**Description**

INFOID:000000005514700

CAN (Controller Area Network) is a serial communication line for real time application. It is an on-vehicle multiplex communication line with high data communication speed and excellent error detection ability. Many electronic control units are equipped onto a vehicle, and each control unit shares information and links with other control units during operation (not independent). In CAN communication, control units are connected with two communication lines (CAN-H line, CAN-L line) allowing a high rate of information transmission with less wiring. Each control unit transmits/receives data but selectively reads required data only.  
 CAN Communication Signal Chart. Refer to [LAN-16, "How to Use CAN Communication Signal Chart"](#).

**DTC Logic**

INFOID:000000005514701

**DTC DETECTION LOGIC**

DTC	Items (CONSULT-III screen terms)	Diagnostic item is detected when...	Possible cause
U1000	CAN COMM CIRCUIT	When A/C auto amp. is not transmitting or receiving CAN communication signal for 2 or more seconds.	CAN communication system

**Diagnosis Procedure**

INFOID:000000005514702

**1. CHECK WITH SELF-DIAGNOSIS FUNCTION OF CONSULT-III**

1. Turn ignition switch ON and wait for 2 or more seconds.
2. Using CONSULT-III, perform "SFLF-DIAGNOSIS RESULTS" of HVAC.

Is "CAN COMM CIRCUIT" displayed?

- YES >> Perform trouble diagnosis for the CAN communication system. Refer to [LAN-17, "Trouble Diagnosis Flow Chart"](#).
- NO >> Perform the intermittent malfunction diagnosis. Refer to [GI-39, "Intermittent Incident"](#).

A  
B  
C  
D  
E  
F  
G  
H  
J  
K  
L  
M  
N  
O  
P

HAC

# U1010 CONTROL UNIT (CAN)

< DTC/CIRCUIT DIAGNOSIS >

[WITH 7 INCH DISPLAY]

## U1010 CONTROL UNIT (CAN)

### Description

INFOID:000000005514703

Initial diagnosis of A/C auto amp.

### DTC Logic

INFOID:000000005514704

### DTC DETECTION LOGIC

DTC	Items (CONSULT-III screen terms)	Diagnostic item is detected when...	Possible cause
U1010	CONTROL UNIT (CAN)	When detecting error during the initial diagnosis of CAN controller of A/C auto amp.	A/C auto amp.

### Diagnosis Procedure

INFOID:000000005514705

#### 1. CHECK WITH SELF-DIAGNOSIS FUNCTION OF CONSULT-III

Using CONSULT-III, perform "SELF-DIAGNOSIS RESULTS" of HVAC.

Is DTC No. "U1010" displayed?

YES >> Replace A/C auto amp.

NO >> INSPECTION END

# B257B, B257C AMBIENT SENSOR

< DTC/CIRCUIT DIAGNOSIS >

[WITH 7 INCH DISPLAY]

## B257B, B257C AMBIENT SENSOR

### Description

INFOID:000000005514706

### COMPONENT DESCRIPTION

#### Ambient Sensor

- The ambient sensor (1) is installed to the front bumper (left back).
- It detects ambient temperature and converts it into a resistance value which is then input into the A/C auto amp.

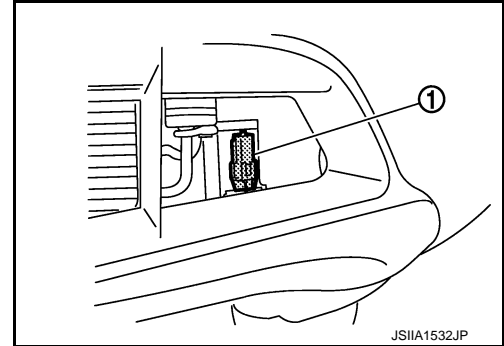

#### Ambient Sensor Circuit

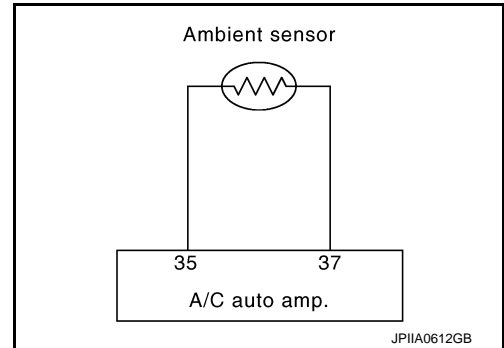

### AMBIENT TEMPERATURE INPUT PROCESS

The A/C auto amp. equips a processing circuit for the ambient sensor input. However, when the temperature detected by the ambient sensor increases quickly, the processing circuit retards the A/C auto amp. function. It only allows the A/C auto amp. to recognize an ambient temperature increase of 0.33°C (0.6°F) per 100 seconds.

As an example, consider stopping for a few minutes after high speed driving. Although the actual ambient temperature has not changed, the temperature detected by the ambient sensor increases. This is because the heat from the engine compartment can radiate to the front bumper area, the location of the ambient sensor.

### DTC Logic

INFOID:000000005514707

#### DTC DETECTION LOGIC

##### NOTE:

- If DTC is displayed along with DTC U1000 or U1010, first diagnose the DTC U1000 or U1010. Refer to [HAC-165, "DTC Logic"](#) or [HAC-166, "DTC Logic"](#).
- If there is an open circuit in the ambient sensor, A/C auto amp. registers extreme cold [-44°C (-47°F)] and adjusts the temperature control warmer.

DTC	Items (CONSULT-III screen terms)	Diagnostic item is detected when...	Possible cause
B257B	AMB TEMP SEN SHORT	Detected temperature at ambient sensor -44°C (-47°F) or less	<ul style="list-style-type: none"> <li>• Ambient sensor</li> <li>• A/C auto amp.</li> </ul>
B257C	AMB TEMP SEN OPEN	Detected temperature at ambient sensor 100°C (212°F) or more	<ul style="list-style-type: none"> <li>• Harness and connector (Ambient sensor circuit is open, or there is a short in the circuit)</li> </ul>

### DTC CONFIRMATION PROCEDURE

1. CHECK WITH SELF-DIAGNOSIS FUNCTION OF CONSULT-III

# B257B, B257C AMBIENT SENSOR

[WITH 7 INCH DISPLAY]

## < DTC/CIRCUIT DIAGNOSIS >

1. Using CONSULT-III, perform "SELF-DIAGNOSIS RESULTS" of HVAC.
2. Check if any DTC No. is displayed in the self-diagnosis results.

### NOTE:

- If DTC is displayed along with DTC U1000 or U1010, first diagnose the DTC U1000 or U1010. Refer to [HAC-165, "DTC Logic"](#) or [HAC-166, "DTC Logic"](#).
- If there is an open circuit in the ambient sensor, A/C auto amp. registers extreme cold [ $-44^{\circ}\text{C}$  ( $-47^{\circ}\text{F}$ )] and adjusts the temperature control warmer.

### Is DTC No. "B257B" or "B257C" displayed?

- YES >> Perform trouble diagnosis for the ambient sensor. Refer to [HAC-168, "Diagnosis Procedure"](#).  
NO >> INSPECTION END

## Diagnosis Procedure

INFOID:000000005514708

### 1. CHECK VOLTAGE BETWEEN AMBIENT SENSOR AND GROUND

1. Disconnect ambient sensor connector.
2. Turn ignition switch ON.
3. Check voltage between ambient sensor harness connector and ground.

(+)		(-)	Voltage
Ambient sensor		—	
Connector	Terminal		
E337	1	Ground	Approx. 5 V

### Is the inspection result normal?

- YES >> GO TO 2.  
NO >> GO TO 4.

### 2. CHECK CIRCUIT CONTINUITY BETWEEN AMBIENT SENSOR AND A/C AUTO AMP.

1. Turn ignition switch OFF.
2. Disconnect A/C auto amp. connector.
3. Check continuity between ambient sensor harness connector and A/C auto amp. harness connector.

Ambient sensor		A/C auto amp.		Continuity
Connector	Terminal	Connector	Terminal	
E337	2	M50	37	Existed

### Is the inspection result normal?

- YES >> GO TO 3.  
NO >> Repair harness or connector.

### 3. CHECK AMBIENT SENSOR

Check ambient sensor. Refer to [HAC-169, "Component Inspection"](#).

### Is the inspection result normal?

- YES >> Replace A/C auto amp.  
NO >> Replace ambient sensor.

### 4. CHECK CIRCUIT CONTINUITY BETWEEN AMBIENT SENSOR AND A/C AUTO AMP.

1. Turn ignition switch OFF.
2. Disconnect A/C auto amp. connector.
3. Check continuity between ambient sensor harness connector and A/C auto amp. harness connector.

Ambient sensor		A/C auto amp.		Continuity
Connector	Terminal	Connector	Terminal	
E337	1	M50	35	Existed

4. Check continuity between ambient sensor harness connector and ground.



# B257B, B257C AMBIENT SENSOR

< DTC/CIRCUIT DIAGNOSIS >

[WITH 7 INCH DISPLAY]

Ambient sensor		—	Continuity
Connector	Terminal		
E337	1	Ground	Not existed

Is the inspection result normal?

YES >> Replace A/C auto amp.

NO >> Repair harness or connector.

## Component Inspection

INFOID:000000005514709

### 1. CHECK AMBIENT SENSOR

1. Turn ignition switch OFF.
2. Disconnect ambient sensor connector. Refer to [VTL-88, "Exploded View"](#).
3. Check resistance between ambient sensor terminals.

Terminal		Condition	Resistance kΩ
		Temperature °C (°F)	
1	2	-15 (5)	12.73
		-10 (14)	9.92
		-5 (23)	7.80
		0 (32)	6.19
		5 (41)	4.95
		10 (50)	3.99
		15 (59)	3.24
		20 (68)	2.65
		25 (77)	2.19
		30 (86)	1.81
		35 (95)	1.51
		40 (104)	1.27
45 (113)	1.07		

Is the inspection result normal?

YES >> INSPECTION END

NO >> Replace ambient sensor.

A  
B  
C  
D  
E  
F  
G  
H  
J  
K  
L  
M  
N  
O  
P

HAC

# B2578, B2579 IN-VEHICLE SENSOR

< DTC/CIRCUIT DIAGNOSIS >

[WITH 7 INCH DISPLAY]

## B2578, B2579 IN-VEHICLE SENSOR

### Description

INFOID:000000005514710

#### In-vehicle Sensor

- The in-vehicle sensor (1) is located on instrument driver lower panel (2).
- It converts variations in compartment air temperature drawn from the aspirator into a resistance value. It is then input into the A/C auto amp.

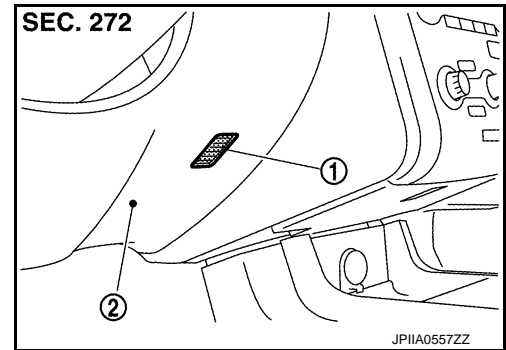

#### In-vehicle Sensor Circuit

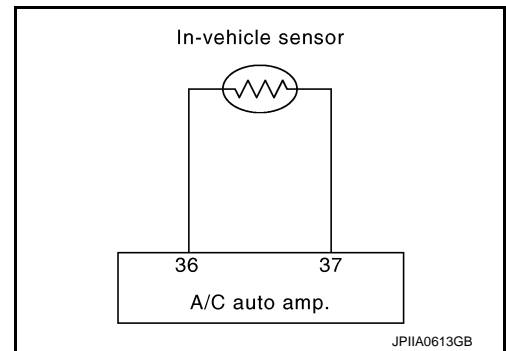

#### Aspirator

The aspirator (1) is located on driver side of heater & cooling unit assembly. It produces vacuum pressure due to air discharged from the heater & cooling unit assembly, continuously taking compartment air in the aspirator.

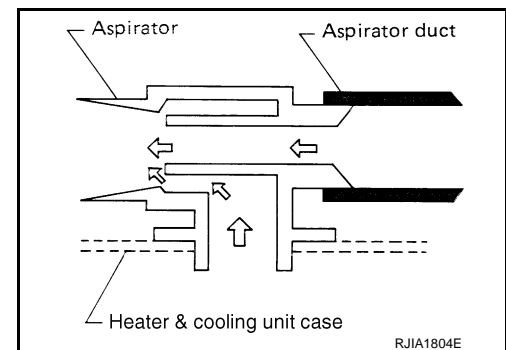
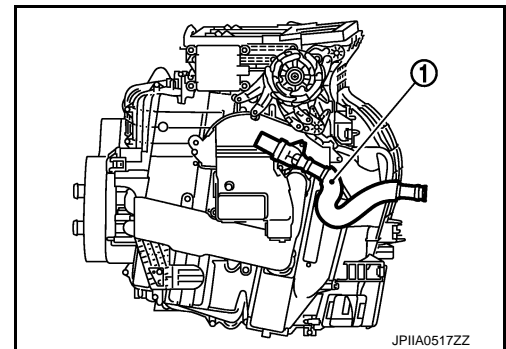

### DTC Logic

INFOID:000000005514711

### DTC DETECTION LOGIC

# B2578, B2579 IN-VEHICLE SENSOR

< DTC/CIRCUIT DIAGNOSIS >

[WITH 7 INCH DISPLAY]

**NOTE:**

If DTC is displayed along with DTC U1000 or U1010, first diagnose the DTC U1000 or U1010. Refer to [HAC-165. "DTC Logic"](#) or [HAC-166. "DTC Logic"](#).

DTC	Items (CONSULT-III screen terms)	Diagnostic item is detected when...	Possible cause
B2578	IN CAR SEN SHORT	Detected temperature at in-vehicle sensor -44°C (-47°F) or less	<ul style="list-style-type: none"> <li>In-vehicle sensor</li> <li>A/C auto amp.</li> <li>Harness and connector (In-vehicle sensor circuit is open, or there is a short in the circuit)</li> </ul>
B2579	IN CAR SEN OPEN	Detected temperature at in-vehicle sensor 100°C (212°F) or more	

**DTC CONFIRMATION PROCEDURE**

**1. CHECK WITH SELF-DIAGNOSIS FUNCTION OF CONSULT-III**

- Using CONSULT-III, perform "SELF-DIAGNOSIS RESULTS" of HVAC.
- Check if any DTC No. is displayed in the self-diagnosis results.

**NOTE:**

If DTC is displayed along with DTC U1000 or U1010, first diagnose the DTC U1000 or U1010. Refer to [HAC-165. "DTC Logic"](#) or [HAC-166. "DTC Logic"](#).

Is DTC No. "B2578" or "B2579" displayed?

- YES >> Perform trouble diagnosis for the in-vehicle sensor. Refer to [HAC-171. "Diagnosis Procedure"](#).
- NO >> INSPECTION END

**Diagnosis Procedure**

INFOID:000000005514712

**1. CHECK VOLTAGE BETWEEN IN-VEHICLE SENSOR AND GROUND**

- Disconnect in-vehicle sensor connector.
- Turn ignition switch ON.
- Check voltage between in-vehicle sensor harness connector and ground.

(+)		(-)	Voltage
Connector	Terminal		
M41	1	Ground	Approx. 5 V

Is the inspection result normal?

- YES >> GO TO 2.
- NO >> GO TO 4.

**2. CHECK CIRCUIT CONTINUITY BETWEEN IN-VEHICLE SENSOR AND A/C AUTO AMP.**

- Turn ignition switch OFF.
- Disconnect A/C auto amp. connector.
- Check continuity between in-vehicle sensor harness connector and A/C auto amp. harness connector.

In-vehicle sensor		A/C auto amp.		Continuity
Connector	Terminal	Connector	Terminal	
M41	2	M50	37	Existed

Is the inspection result normal?

- YES >> GO TO 3.
- NO >> Repair harness or connector.

**3. CHECK IN-VEHICLE SENSOR**

Check in-vehicle sensor. Refer to [HAC-172. "Component Inspection"](#).

Is the inspection result normal?

- YES >> Replace A/C auto amp.

## B2578, B2579 IN-VEHICLE SENSOR

< DTC/CIRCUIT DIAGNOSIS >

[WITH 7 INCH DISPLAY]

NO >> Replace in-vehicle sensor.

### 4. CHECK CIRCUIT CONTINUITY BETWEEN IN-VEHICLE SENSOR AND A/C AUTO AMP.

1. Turn ignition switch OFF.
2. Disconnect A/C auto amp. connector.
3. Check continuity between in-vehicle sensor harness connector and A/C auto amp. harness connector.

In-vehicle sensor		A/C auto amp.		Continuity
Connector	Terminal	Connector	Terminal	
M41	1	M50	36	Existed

4. Check continuity between in-vehicle sensor harness connector and ground.

In-vehicle sensor		—	Continuity
Connector	Terminal		
M41	1	Ground	Not existed

Is the inspection result normal?

YES >> Replace A/C auto amp.

NO >> Repair harness or connector.

## Component Inspection

INFOID:000000005514713

### 1. CHECK IN-VEHICLE SENSOR

1. Turn ignition switch OFF.
2. Disconnect in-vehicle sensor connector. Refer to [VTL-89. "Exploded View"](#).
3. Check resistance between in-vehicle sensor terminals.

Terminal		Condition	Resistance kΩ
		Temperature °C (°F)	
1	2	-15 (5)	12.73
		-10 (14)	9.92
		-5 (23)	7.80
		0 (32)	6.19
		5 (41)	4.95
		10 (50)	3.99
		15 (59)	3.24
		20 (68)	2.65
		25 (77)	2.19
		30 (86)	1.81
		35 (95)	1.51
		40 (104)	1.27
		45 (113)	1.07

Is the inspection result normal?

YES >> INSPECTION END

NO >> Replace in-vehicle sensor.

# B2581, B2582 INTAKE SENSOR

< DTC/CIRCUIT DIAGNOSIS >

[WITH 7 INCH DISPLAY]

## B2581, B2582 INTAKE SENSOR

### Description

INFOID:000000005514714

#### Intake Sensor

- The intake sensor (1) is located on the evaporator (2).
- It converts air temperature after it passes through the evaporator into a resistance value which is then input to the A/C auto amp.

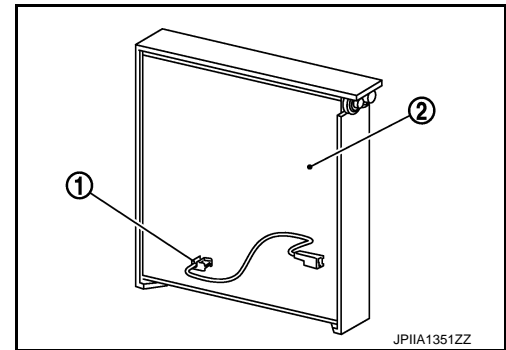

#### Intake Sensor Circuit

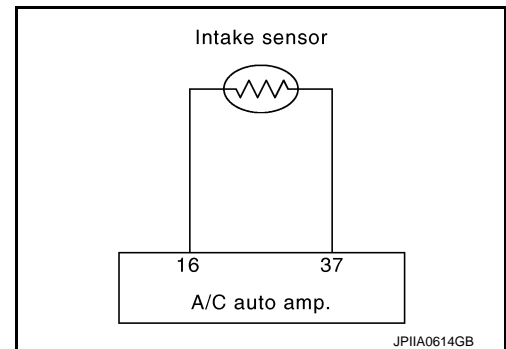

### DTC Logic

INFOID:000000005514715

#### DTC DETECTION LOGIC

##### NOTE:

If DTC is displayed along with DTC U1000 or U1010, first diagnose the DTC U1000 or U1010. Refer to [HAC-165, "DTC Logic"](#) or [HAC-166, "DTC Logic"](#).

DTC	Items (CONSULT-III screen terms)	Diagnostic item is detected when...	Possible cause
B2581	EVAP TEMP SEN SHORT	Detected temperature at intake sensor -33°C (-27°F) or less	<ul style="list-style-type: none"> <li>• Intake sensor</li> <li>• A/C auto amp.</li> <li>• Harness and connector (Intake sensor circuit is open, or there is a short in the circuit)</li> </ul>
B2582	EVAP TEMP SEN OPEN	Detected temperature at intake sensor 69°C (156°F) or more	

#### DTC CONFIRMATION PROCEDURE

##### 1. CHECK WITH SELF-DIAGNOSIS FUNCTION OF CONSULT-III

1. Using CONSULT-III, perform "SELF-DIAGNOSIS RESULTS" of HVAC.
2. Check if any DTC No. is displayed in the self-diagnosis results.

##### NOTE:

If DTC is displayed along with DTC U1000 or U1010, first diagnose the DTC U1000 or U1010. Refer to [HAC-165, "DTC Logic"](#) or [HAC-166, "DTC Logic"](#).

Is DTC No. "B2581" or "B2582" displayed?

YES >> Perform trouble diagnosis for the intake sensor. Refer to [HAC-173, "Diagnosis Procedure"](#).

NO >> INSPECTION END

### Diagnosis Procedure

INFOID:000000005514716

##### 1. CHECK VOLTAGE BETWEEN INTAKE SENSOR AND GROUND

# B2581, B2582 INTAKE SENSOR

[WITH 7 INCH DISPLAY]

## < DTC/CIRCUIT DIAGNOSIS >

1. Disconnect intake sensor connector.
2. Turn ignition switch ON.
3. Check voltage between intake sensor harness connector and ground.

(+)		(-)	Voltage
Intake sensor		—	
Connector	Terminal		
M42	1	Ground	Approx. 5 V

Is the inspection result normal?

- YES >> GO TO 2.  
NO >> GO TO 4.

## 2.CHECK CIRCUIT CONTINUITY BETWEEN INTAKE SENSOR AND A/C AUTO AMP.

1. Turn ignition switch OFF.
2. Disconnect A/C auto amp. connector.
3. Check continuity between intake sensor harness connector and A/C auto amp. harness connector.

Intake sensor		A/C auto amp.		Continuity
Connector	Terminal	Connector	Terminal	
M42	2	M50	37	Existed

Is the inspection result normal?

- YES >> GO TO 3.  
NO >> Repair harness or connector.

## 3.CHECK INTAKE SENSOR

Check intake sensor. Refer to [HAC-174, "Component Inspection"](#).

Is the inspection result normal?

- YES >> Replace A/C auto amp.  
NO >> Replace intake sensor.

## 4.CHECK CIRCUIT CONTINUITY BETWEEN INTAKE SENSOR AND A/C AUTO AMP.

1. Turn ignition switch OFF.
2. Disconnect A/C auto amp. connector.
3. Check continuity between intake sensor harness connector and A/C auto amp. harness connector.

Intake sensor		A/C auto amp.		Continuity
Connector	Terminal	Connector	Terminal	
M42	1	M50	16	Existed

4. Check continuity between intake sensor harness connector and ground.

Intake sensor		—	Continuity
Connector	Terminal		
M42	1	Ground	Not existed

Is the inspection result normal?

- YES >> Replace A/C auto amp.  
NO >> Repair harness or connector.

## Component Inspection

INFOID:000000005514717

## 1.CHECK INTAKE SENSOR

1. Turn ignition switch OFF.
2. Disconnect intake sensor connector.
3. Check resistance between intake sensor terminals.

# B2581, B2582 INTAKE SENSOR

< DTC/CIRCUIT DIAGNOSIS >

[WITH 7 INCH DISPLAY]

Terminal		Condition	Resistance kΩ
		Temperature °C (°F)	
1	2	-15 (5)	18.63
		-10 (14)	14.15
		-5 (23)	10.86
		0 (32)	8.41
		5 (41)	6.58
		10 (50)	5.19
		15 (59)	4.12
		20 (68)	3.30
		25 (77)	2.67
		30 (86)	2.17
		35 (95)	1.78
		40 (104)	1.46
		45 (113)	1.21

Is the inspection result normal?

YES >> INSPECTION END

NO >> Replace intake sensor.

A

B

C

D

E

F

G

H

HAC

J

K

L

M

N

O

P

# B2630, B2631 SUNLOAD SENSOR

< DTC/CIRCUIT DIAGNOSIS >

[WITH 7 INCH DISPLAY]

## B2630, B2631 SUNLOAD SENSOR

### Description

INFOID:000000005514718

### COMPONENT DESCRIPTION

#### Sunload Sensor

- The sunload sensor (1) is located on the driver's side instrument panel & pad.
- It detects sunload entering through windshield by means of a photo diode. The sensor converts the sunload into a current value which is then input into the A/C auto amp.

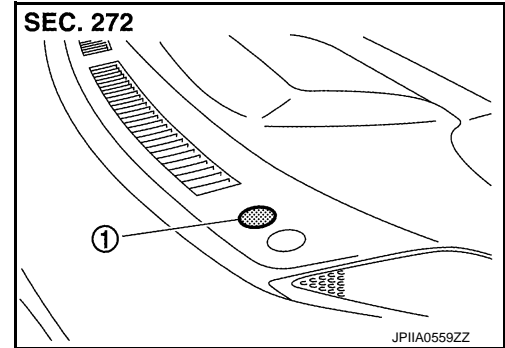

#### Sunload Sensor Circuit

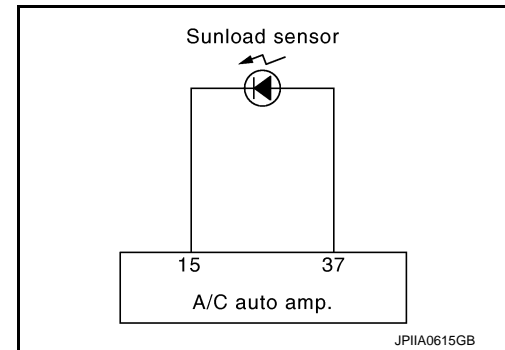

### SUNLOAD INPUT PROCESS

The A/C auto amp. also equips a processing circuit which averages the variations in detected sunload over a period of time. This prevents drastic swings in the air temperature control system operation due to small or quick variations in detected sunload.

For example, consider driving along a road bordered by an occasional group of large trees. The sunload detected by the sunload sensor varies whenever the trees obstruct the sunlight. The processing circuit averages the detected sunload over a period of time, so that the (insignificant) effect of the trees momentarily obstructing the sunlight does not cause any change in the air temperature control system operation. On the other hand, shortly after entering a long tunnel, the system recognizes the change in sunload, and the system reacts accordingly.

### DTC Logic

INFOID:000000005514719

### DTC DETECTION LOGIC

#### NOTE:

- If DTC is displayed along with DTC U1000 or U1010, first diagnose the DTC U1000 or U1010. Refer to [HAC-165. "DTC Logic"](#) or [HAC-166. "DTC Logic"](#).
- Sunload sensor may register a malfunction when indoors, at dusk, or at other times when light is insufficient. When performing the diagnosis indoors, light the sunload sensor with a lamp (60W or more).

DTC	Items (CONSULT-III screen terms)	Diagnostic item is detected when...	Possible cause
B2630	SUNLOAD SEN SHORT	Detected calorie at sunload sensor 64.7 w/m <sup>2</sup> (56 kcal/m <sup>2</sup> ·h) or less	<ul style="list-style-type: none"> <li>• Sunload sensor</li> <li>• A/C auto amp.</li> <li>• Harness and connector</li> </ul>
B2631	SUNLOAD SEN OPEN	Detected calorie at sunload sensor 2832 w/m <sup>2</sup> (2436 kcal/m <sup>2</sup> ·h) or more	(Sunload sensor circuit is open, or there is a short in the circuit)



# B2630, B2631 SUNLOAD SENSOR

< DTC/CIRCUIT DIAGNOSIS >

[WITH 7 INCH DISPLAY]

## DTC CONFIRMATION PROCEDURE

### 1. CHECK WITH SELF-DIAGNOSIS FUNCTION OF CONSULT-III

1. Using CONSULT-III, perform "SELF-DIAGNOSIS RESULTS" of HVAC.
2. Check if any DTC No. is displayed in the self-diagnosis results.

#### NOTE:

- If DTC is displayed along with DTC U1000 or U1010, first diagnose the DTC U1000 or U1010. Refer to [HAC-165, "DTC Logic"](#) or [HAC-166, "DTC Logic"](#).
- Sunload sensor may register a malfunction when indoors, at dusk, or at other times when light is insufficient. When performing the diagnosis indoors, light the sunload sensor with a lamp (60W or more).

Is DTC No. "B2630" or "B2631" displayed?

- YES >> Perform trouble diagnosis for the sunload sensor. Refer to [HAC-177, "Diagnosis Procedure"](#).  
NO >> INSPECTION END

## Diagnosis Procedure

INFOID:000000005514720

### 1. CHECK VOLTAGE BETWEEN SUNLOAD SENSOR AND GROUND

1. Disconnect sunload sensor connector.
2. Turn ignition switch ON.
3. Check voltage between sunload sensor harness connector and ground.

(+)		(-)	Voltage
Sunload sensor		—	
Connector	Terminal		
M74	1	Ground	Approx. 5 V

Is the inspection result normal?

- YES >> GO TO 2.  
NO >> GO TO 4.

### 2. CHECK CIRCUIT CONTINUITY BETWEEN SUNLOAD SENSOR AND A/C AUTO AMP.

1. Turn ignition switch OFF.
2. Disconnect A/C auto amp. connector.
3. Check continuity between sunload sensor harness connector and A/C auto amp. harness connector.

Sunload sensor		A/C auto amp.		Continuity
Connector	Terminal	Connector	Terminal	
M74	2	M50	37	Existed

Is the inspection result normal?

- YES >> GO TO 3.  
NO >> Repair harness or connector.

### 3. CHECK SUNLOAD SENSOR

1. Reconnect sunload sensor connector and A/C auto amp. connector.
2. Check sunload sensor. Refer to [HAC-178, "Component Inspection"](#).

Is the inspection result normal?

- YES >> Replace A/C auto amp.  
NO >> Replace sunload sensor.

### 4. CHECK CIRCUIT CONTINUITY BETWEEN SUNLOAD SENSOR AND A/C AUTO AMP.

1. Turn ignition switch OFF.
2. Disconnect A/C auto amp. connector.
3. Check continuity between sunload sensor harness connector and A/C auto amp. harness connector.

# B2630, B2631 SUNLOAD SENSOR

< DTC/CIRCUIT DIAGNOSIS >

[WITH 7 INCH DISPLAY]

Sunload sensor		A/C auto amp.		Continuity
Connector	Terminal	Connector	Terminal	
M74	1	M50	15	Existed

4. Check continuity between sunload sensor harness connector and ground.

Sunload sensor		—	Continuity
Connector	Terminal		
M74	1	Ground	Not existed

Is the inspection result normal?

YES >> Replace A/C auto amp.

NO >> Repair harness or connector.

## Component Inspection

INFOID:000000005514721

### 1. CHECK SUNLOAD SENSOR

1. Turn ignition switch ON.
2. Check voltage between A/C auto amp. harness connector and ground.

(+) A/C auto amp.		(-)
Connector	Terminal	—
M50	15	Ground

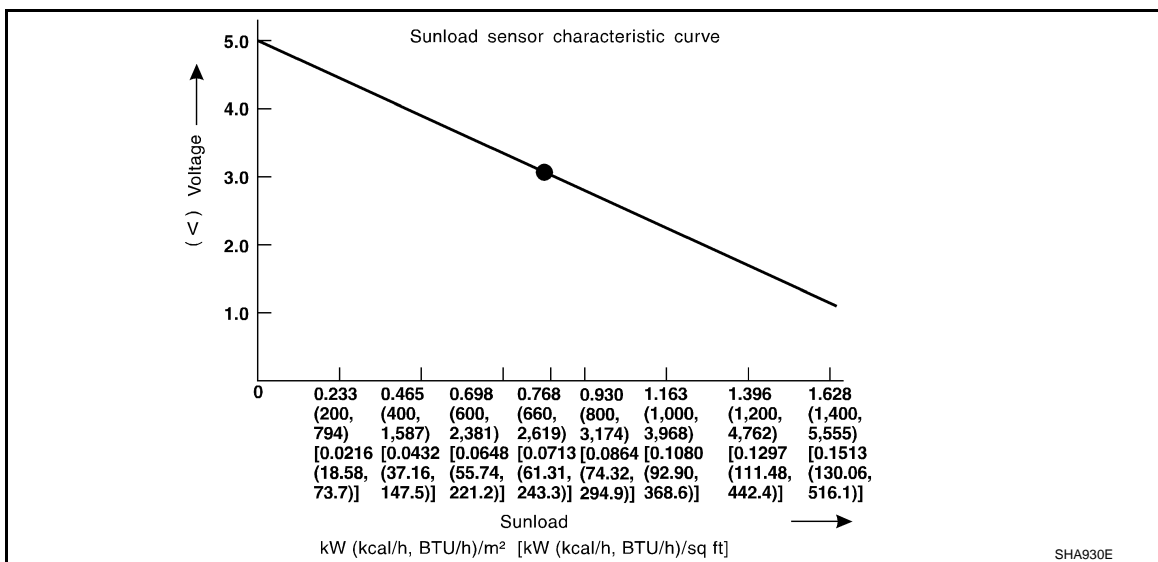

**NOTE:**

Select a place where sunshine directly on it when checking sunload sensor.

Is the inspection result normal?

YES >> INSPECTION END

NO >> Replace sunload sensor.

# B2632, B2633 AIR MIX DOOR MOTOR (DRIVER SIDE)

< DTC/CIRCUIT DIAGNOSIS >

[WITH 7 INCH DISPLAY]

## B2632, B2633 AIR MIX DOOR MOTOR (DRIVER SIDE)

### Description

INFOID:000000005514722

### COMPONENT DESCRIPTION

Air Mix Door Motor (Driver Side)

- The air mix door motor (driver side) (1) are attached to the heater & cooling unit assembly.

←: Vehicle front

- It rotates so that the air mix door is opened or closed to a position set by the A/C auto amp.
- Motor rotation is then conveyed through a shaft and the air mix door position feedback is then sent to the A/C auto amp. by PBR built-in air mix door motor.

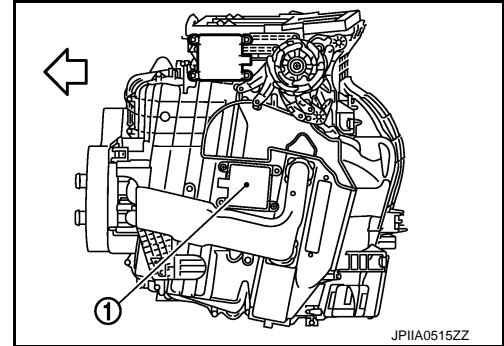

### DTC Logic

INFOID:000000005514723

### DTC DETECTION LOGIC

#### NOTE:

If DTC is displayed along with DTC U1000 or U1010, first diagnose the DTC U1000 or U1010. Refer to [HAC-165. "DTC Logic"](#) or [HAC-166. "DTC Logic"](#).

DTC	Items (CONSULT-III screen terms)	Diagnostic item is detected when...	Possible cause
B2632	DR AIRMIX ACTR SHORT	Air mix door PBR (driver side) position 95% or less	<ul style="list-style-type: none"><li>• Air mix door motor (PBR internal circuit is open or shorted)</li><li>• A/C auto amp.</li><li>• Harness and connector (LAN communication line is open or shorted)</li></ul>
B2633	DR AIRMIX ACTR OPEN	Air mix door PBR (driver side) position 5% or more	

HAC

### DTC CONFIRMATION PROCEDURE

#### 1. CHECK WITH SELF-DIAGNOSIS FUNCTION OF CONSULT-III

1. Using CONSULT-III, perform "SELF-DIAGNOSIS RESULTS" of HVAC.
2. Check if any DTC No. is displayed in the self-diagnosis results.

#### NOTE:

If DTC is displayed along with DTC U1000 or U1010, first diagnose the DTC U1000 or U1010. Refer to [HAC-165. "DTC Logic"](#) or [HAC-166. "DTC Logic"](#).

Is DTC No. "B2632" or "B2633" displayed?

YES >> Perform trouble diagnosis for the air mix door motor (driver side). Refer to [HAC-180. "Diagnosis Procedure"](#).

NO >> GO TO 2.

#### 2. FUNCTION INSPECTION

1. Press temperature control "UP" dial (driver side) until 32°C (90°F) is displayed.
2. Check for warm air at discharge air outlets.
3. Operate the compressor.
4. Press temperature control "DOWN" dial (driver side) until 18°C (60°F) is displayed.
5. Check for cool air at air discharge outlets.

Does it operate normally?

YES >> END.

NO >> Check air mix door motor (driver side) installation, and repair or replace the malfunctioning parts.

# B2632, B2633 AIR MIX DOOR MOTOR (DRIVER SIDE)

< DTC/CIRCUIT DIAGNOSIS >

[WITH 7 INCH DISPLAY]

INFOID:000000005514724

## Diagnosis Procedure

### 1. CHECK POWER SUPPLY FOR AIR MIX DOOR MOTOR (DRIVER SIDE)

Check voltage between air mix door motor (driver side) harness connector and ground.

(+)		(-)	Voltage
Air mix door motor (driver side)		—	
Connector	Terminal		
M306	1	Ground	Battery voltage

Is the inspection result normal?

YES >> GO TO 2.

NO >> Repair the harnesses or connectors.

### 2. CHECK SIGNAL FOR AIR MIX DOOR MOTOR (DRIVER SIDE)

Check the output waveform (LAN signal) between air mix door motor (driver side) harness connector and ground using an oscilloscope.

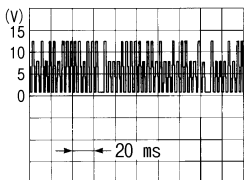
(+)		(-)	Voltage
Air mix door motor (driver side)		—	
Connector	Terminal		
M306	3	Ground	 SJIA1453J

Is the inspection result normal?

YES >> GO TO 3.

NO >> Repair the harnesses or connectors.

### 3. CHECK AIR MIX DOOR MOTOR (DRIVER SIDE) GROUND CIRCUIT

1. Turn ignition switch OFF.
2. Disconnect air mix door motor (driver side) connector.
3. Check continuity between air mix door motor (driver side) harness connector and ground.

Air mix door motor (driver side)		(-)	Continuity
		—	
Connector	Terminal		
M306	2	Ground	Existed

Is the inspection result normal?

YES >> Replace air mix door motor (driver side).

NO >> Repair harness or connector.

# B2634, B2635 AIR MIX DOOR MOTOR (PASSENGER SIDE)

< DTC/CIRCUIT DIAGNOSIS >

[WITH 7 INCH DISPLAY]

## B2634, B2635 AIR MIX DOOR MOTOR (PASSENGER SIDE)

### Description

INFOID:000000005514725

### COMPONENT DESCRIPTION

Air Mix Door Motor (Passenger Side)

- The air mix door motor (passenger side) (1) are attached to the heater & cooling unit assembly.

←: Vehicle front

- It rotates so that the air mix door is opened or closed to a position set by the A/C auto amp.
- Motor rotation is then conveyed through a shaft and the air mix door position feedback is then sent to the A/C auto amp. by PBR built-in air mix door motor.

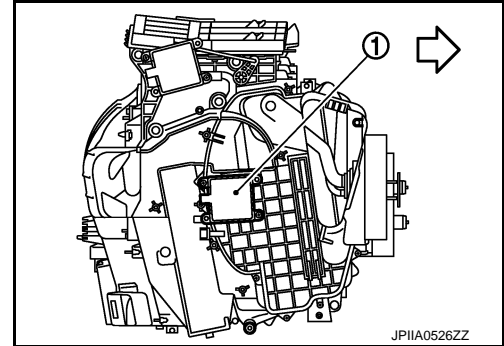

### DTC Logic

INFOID:000000005514726

### DTC DETECTION LOGIC

#### NOTE:

If DTC is displayed along with DTC U1000 or U1010, first diagnose the DTC U1000 or U1010. Refer to [HAC-165. "DTC Logic"](#) or [HAC-166. "DTC Logic"](#).

DTC	Items (CONSULT-III screen terms)	Diagnostic item is detected when...	Possible cause
B2634	PASS AIRMIX ACTR SHORT	Air mix door PBR (passenger side) position 95% or less	• Air mix door motor (PBR internal circuit is open or shorted) • A/C auto amp. • Harness and connector (LAN communication line is open or shorted)
B2635	PASS AIRMIX ACTR OPEN	Air mix door PBR (passenger side) position 5% or more	

HAC

### DTC CONFIRMATION PROCEDURE

#### 1. CHECK WITH SELF-DIAGNOSIS FUNCTION OF CONSULT-III

1. Using CONSULT-III, perform "SELF-DIAGNOSIS RESULTS" of HVAC.
2. Check if any DTC No. is displayed in the self-diagnosis results.

#### NOTE:

If DTC is displayed along with DTC U1000 or U1010, first diagnose the DTC U1000 or U1010. Refer to [HAC-165. "DTC Logic"](#) or [HAC-166. "DTC Logic"](#).

Is DTC No. "B2634" or "B2635" displayed?

YES >> Perform trouble diagnosis for the air mix door motor (passenger side). Refer to [HAC-182. "Diagnosis Procedure"](#).

NO >> GO TO 2.

#### 2. FUNCTION INSPECTION

1. Press temperature control "UP" dial (passenger side) until 32°C (90°F) is displayed.
2. Check for warm air at discharge air outlets.
3. Operate the compressor.
4. Press temperature control "DOWN" dial (passenger side) until 18°C (60°F) is displayed.
5. Check for cool air at air discharge outlets.

Does it operate normally?

YES >> END.

NO >> Check air mix door motor (passenger side) installation, and repair or replace the malfunctioning parts.

# B2634, B2635 AIR MIX DOOR MOTOR (PASSENGER SIDE)

< DTC/CIRCUIT DIAGNOSIS >

[WITH 7 INCH DISPLAY]

INFOID:000000005514727

## Diagnosis Procedure

### 1. CHECK POWER SUPPLY FOR AIR MIX DOOR MOTOR (PASSENGER SIDE)

Check voltage between air mix door motor (passenger side) harness connector and ground.

(+)		(-)	Voltage
Air mix door motor (passenger side)		—	
Connector	Terminal		
M307	1	Ground	Battery voltage

Is the inspection result normal?

YES >> GO TO 2.

NO >> Repair the harnesses or connectors.

### 2. CHECK SIGNAL FOR AIR MIX DOOR MOTOR (PASSENGER SIDE)

Check the output waveform (LAN signal) between air mix door motor (passenger side) harness connector and ground using an oscilloscope.

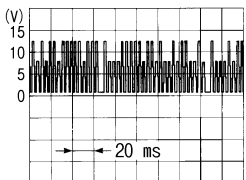
(+)		(-)	Voltage
Air mix door motor (passenger side)		—	
Connector	Terminal		
M307	3	Ground	 SJIA1453J

Is the inspection result normal?

YES >> GO TO 3.

NO >> Repair the harnesses or connectors.

### 3. CHECK AIR MIX DOOR MOTOR (PASSENGER SIDE) GROUND CIRCUIT

1. Turn ignition switch OFF.
2. Disconnect air mix door motor (passenger side) connector.
3. Check continuity between air mix door motor (passenger side) harness connector and ground.

Air mix door motor (passenger side)		(-)	Continuity
		—	
Connector	Terminal		
M307	2	Ground	Existed

Is the inspection result normal?

YES >> Replace air mix door motor (passenger side).

NO >> Repair harness or connector.

# B2636, B2637, B2638, B2639, B2654, B2655 MODE DOOR MOTOR

< DTC/CIRCUIT DIAGNOSIS >

[WITH 7 INCH DISPLAY]

## B2636, B2637, B2638, B2639, B2654, B2655 MODE DOOR MOTOR

### Description

INFOID:000000005514728

### COMPONENT DESCRIPTION

#### Mode Door Motor

- The mode door motor (1) are attached to the heater & cooling unit assembly.
- It rotates so that air is discharged from the outlet set by the A/C auto amp. Motor rotation is conveyed to a link which activates the mode door.

←: Vehicle front

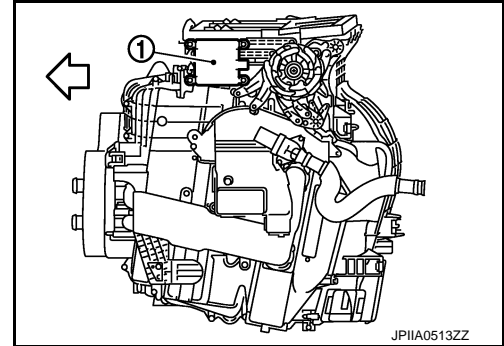

### DTC Logic

INFOID:000000005514729

### DTC DETECTION LOGIC

#### NOTE:

If DTC is displayed along with DTC U1000 or U1010, first diagnose the DTC U1000 or U1010. Refer to [HAC-165, "DTC Logic"](#) or [HAC-166, "DTC Logic"](#).

DTC	Items (CONSULT-III screen terms)	Diagnostic item is detected when...	Possible cause
B2636	DR VENT DOOR FAIL	When the malfunctioning door position is detected at VENT position	<ul style="list-style-type: none"> <li>• Mode door motor (PBR internal circuit is open or shorted)</li> <li>• A/C auto amp.</li> <li>• Harness and connector (LAN communication line is open or shorted)</li> </ul>
B2637	DR B/L DOOR FAIL	When the malfunctioning door position is detected at B/L position	
B2638	DR D/F1 DOOR FAIL	When the malfunctioning door position is detected at FOOT position	
B2639	DR DEF DOOR FAIL	When the malfunctioning door position is detected at DEF position	
B2654	D/F2 DOOR FAIL	When the malfunctioning door position is detected at D/F position	
B2655	B/L2 DOOR FAIL	When the malfunctioning door position is detected at B/L2 position	

### DTC CONFIRMATION PROCEDURE

#### 1. CHECK WITH SELF-DIAGNOSIS FUNCTION OF CONSULT-III

1. Using CONSULT-III, perform "SELF-DIAGNOSIS RESULTS" of HVAC.
2. Check if any DTC No. is displayed in the self-diagnosis results.

#### NOTE:

If DTC is displayed along with DTC U1000 or U1010, first diagnose the DTC U1000 or U1010. Refer to [HAC-165, "DTC Logic"](#) or [HAC-166, "DTC Logic"](#).

Is DTC No. "B2636", "B2637", "B2638", "B2639", "B2654" or "B2655" displayed?

- YES >> Perform trouble diagnosis for the mode door motor. Refer to [HAC-184, "Diagnosis Procedure"](#).  
 NO >> GO TO 2.

#### 2. FUNCTION INSPECTION

1. Press MODE switch and DEF switch.
2. Each position indicator should change shape.

# B2636, B2637, B2638, B2639, B2654, B2655 MODE DOOR MOTOR

< DTC/CIRCUIT DIAGNOSIS >

[WITH 7 INCH DISPLAY]

3. Confirm that air discharge comes out according to the air distribution table at below. Refer to [HAC-138](#), "[System Description](#)".

Discharge air flow							
Mode position indication	Condition	Air outlet/distribution					
		VENT			FOOT		DEF
		Front	Upper	Rear	Front	Rear	
	DUAL switch: OFF UPPER VENT switch : ON	81%	8%	11%	—	—	—
		41%	10%	17%	24%	8%	—
		12%	12%	16%	27%	10%	23%
		11%	11%	14%	25%	10%	29%
		11%	11%	12%	—	—	66%

JPIIA0509GB

Discharge air flow							
Mode position indication	Condition	Air outlet/distribution					
		VENT			FOOT		DEF
		Front	Upper	Rear	Front	Rear	
	DUAL switch: OFF UPPER VENT switch : OFF	88%	—	12%	—	—	—
		47%	—	18%	26%	9%	—
		13%	—	17%	33%	12%	25%
		12%	—	16%	28%	12%	32%
		11%	—	15%	—	—	74%

JPIIA0510GB

## NOTE:

Confirm that the compressor clutch is engaged (Sound or visual inspection) and intake door position is at FRE when DEF ( ) or D/F ( ) is selected.

### Does it operate normally?

YES >> INSPECTION END

NO >> Check mode door motor installation, and repair or replace the malfunctioning parts.

## Diagnosis Procedure

INFOID:000000005514730

### 1.CHECK POWER SUPPLY FOR MODE DOOR MOTOR

Check voltage between mode door motor harness connector and ground.

(+)		(-)	Voltage
Mode door motor		—	
Connector	Terminal		
M310	1	Ground	Battery voltage

### Is the inspection result normal?

YES >> GO TO 2.

NO >> Repair harness or connector.

### 2.CHECK SIGNAL FOR MODE DOOR MOTOR

Confirm A/C LAN signal between mode door motor harness connector and ground using an oscilloscope.



# B2636, B2637, B2638, B2639, B2654, B2655 MODE DOOR MOTOR

< DTC/CIRCUIT DIAGNOSIS >

[WITH 7 INCH DISPLAY]

(+)		(-)	Voltage
Mode door motor		—	
Connector	Terminal		
M310	3	Ground	

Is the inspection result normal?

YES >> GO TO 3.

NO >> Repair harness or connector.

### 3.CHECK MODE DOOR MOTOR GROUND CIRCUIT

1. Turn ignition switch OFF.
2. Disconnect mode door motor connector.
3. Check continuity between mode door motor harness connector and ground.

Mode door motor		—	Continuity
Connector	Terminal		
M310	2	Ground	Existed

Is the inspection result normal?

YES >> Replace mode door motor.

NO >> Repair harness or connector.

A  
B  
C  
D  
E  
F  
G  
H  
J  
K  
L  
M  
N  
O  
P

HAC

# B263D, B263E, B263F INTAKE DOOR MOTOR

< DTC/CIRCUIT DIAGNOSIS >

[WITH 7 INCH DISPLAY]

## B263D, B263E, B263F INTAKE DOOR MOTOR

### Description

INFOID:000000005514731

#### COMPONENT DESCRIPTION

Intake Door Motor

- The intake door motor (1) is attached to the blower unit.

←: Vehicle front

- It rotates so that air is drawn from inlets set by the A/C auto amp. Motor rotation is conveyed to a lever which activates the intake door.

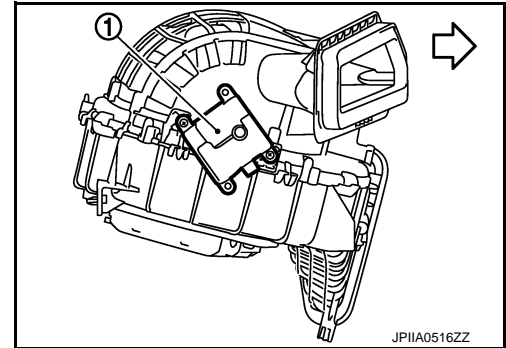

INFOID:000000005514732

### DTC Logic

#### DTC DETECTION LOGIC

##### NOTE:

If DTC is displayed along with DTC U1000 or U1010, first diagnose the DTC U1000 or U1010. Refer to [HAC-165. "DTC Logic"](#) or [HAC-166. "DTC Logic"](#).

DTC	Items (CONSULT-III screen terms)	Diagnostic item is detected when...	Possible cause
B263D	FRE DOOR FAIL	When the malfunctioning intake door position is detected at FRE position	<ul style="list-style-type: none"><li>• Intake door motor (PBR internal circuit is open or shorted)</li><li>• A/C auto amp.</li><li>• Harness and connector (LAN communication line is open or shorted)</li></ul>
B263E	20P FRE DOOR FAIL	When the malfunctioning intake door position is detected at 20%FRE position	
B263F	REC DOOR FAIL	When the malfunctioning intake door position is detected at REC position	

#### DTC CONFIRMATION PROCEDURE

##### 1. CHECK WITH SELF-DIAGNOSIS FUNCTION OF CONSULT-III

1. Using CONSULT-III, perform "SELF-DIAGNOSIS RESULTS" of HVAC.
2. Check if any DTC No. is displayed in the self-diagnosis results.

##### NOTE:

If DTC is displayed along with DTC U1000 or U1010, first diagnose the DTC U1000 or U1010. Refer to [HAC-165. "DTC Logic"](#) or [HAC-166. "DTC Logic"](#).

Is DTC No. "B263D", "B263E" or "B263F" displayed?

- YES >> Perform trouble diagnosis for the intake door motor. Refer to [HAC-187. "Diagnosis Procedure"](#).  
NO >> GO TO 2.

##### 2. FUNCTION INSPECTION

1. Press intake switch.
2. The intake switch indicator is turned ON. (REC position)
3. Listen for intake door position change (Slight change of blower sound can be heard.).
4. Press intake switch again.
5. The intake switch indicator is turned OFF. (FRE position)
6. Listen for intake door position change (Slight change of blower sound can be heard.).

Does it operate normally?

- YES >> INSPECTION END  
NO >> Check intake door motor installation, and repair or replace the malfunctioning parts.

# B263D, B263E, B263F INTAKE DOOR MOTOR

< DTC/CIRCUIT DIAGNOSIS >

[WITH 7 INCH DISPLAY]

## Diagnosis Procedure

INFOID:00000000514733

### 1. CHECK POWER SUPPLY FOR INTAKE DOOR MOTOR

Check voltage between intake door motor harness connector and ground.

(+)		(-)	Voltage
Intake door motor		—	
Connector	Terminal		
M304	1	Ground	Battery voltage

Is the inspection result normal?

YES >> GO TO 2.

NO >> Repair harness or connector.

### 2. CHECK SIGNAL FOR INTAKE DOOR MOTOR

Confirm A/C LAN signal between intake door motor harness connector and ground using an oscilloscope.

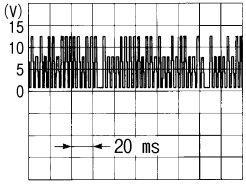
(+)		(-)	Voltage
Intake door motor		—	
Connector	Terminal		
M304	3	Ground	 SJIA1453J

Is the inspection result normal?

YES >> GO TO 3.

NO >> Repair harness or connector.

### 3. CHECK INTAKE DOOR MOTOR GROUND CIRCUIT

1. Turn ignition switch OFF.
2. Disconnect intake door motor connector.
3. Check continuity between intake door motor harness connector and ground.

Intake door motor		(-)	Continuity
Connector	Terminal	—	
M304	2	Ground	Existed

Is the inspection result normal?

YES >> Replace intake door motor.

NO >> Repair harness or connector.

A  
B  
C  
D  
E  
F  
G  
H  
I  
J  
K  
L  
M  
N  
O  
P

HAC

# B2661, B2662, B2663 UPPER VENTILATOR DOOR MOTOR

< DTC/CIRCUIT DIAGNOSIS >

[WITH 7 INCH DISPLAY]

## B2661, B2662, B2663 UPPER VENTILATOR DOOR MOTOR

### Description

INFOID:000000005514734

#### COMPONENT DESCRIPTION

Upper Ventilator Door Motor

- The upper ventilator door motor (1) are attached to the heater & cooling unit assembly.

←: Vehicle front

- Upper ventilator door motor operates by UPPER VENT switch ON/OFF when the DEF switch is OFF.
- Motor rotation is conveyed to a link which activates the upper ventilator door.

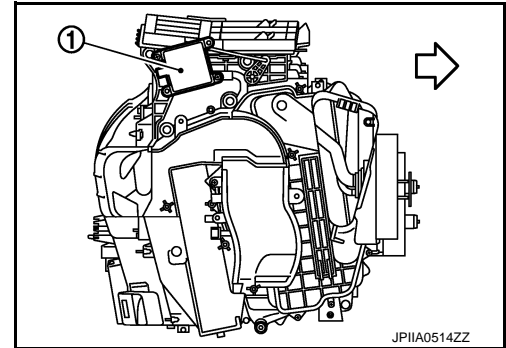

JPIIA0514ZZ

### DTC Logic

INFOID:000000005514735

#### DTC DETECTION LOGIC

##### NOTE:

If DTC is displayed along with DTC U1000 or U1010, first diagnose the DTC U1000 or U1010. Refer to [HAC-165. "DTC Logic"](#) or [HAC-166. "DTC Logic"](#).

DTC	Items (CONSULT-III screen terms)	Diagnostic item is detected when...	Possible cause
B2661	UPPER VENT DOOR OPEN POSI FAIL	When the malfunctioning upper ventilator door position is detected at open position.	<ul style="list-style-type: none"><li>• Upper ventilator door motor (PBR internal circuit is open or shorted)</li><li>• A/C auto amp.</li><li>• Harness and connector (LAN communication line is open or shorted)</li></ul>
B2662	UPPER VENT DOOR MID POSI FAIL	When the malfunctioning upper ventilator door position is detected at middle position.	
B2663	UPPER VENT DOOR SHUT POSI FAIL	When the malfunctioning upper ventilator door position is detected at shut position.	

#### DTC CONFIRMATION PROCEDURE

##### 1. CHECK WITH SELF-DIAGNOSIS FUNCTION OF CONSULT-III

1. Using CONSULT-III, perform "SELF-DIAGNOSIS RESULTS" of HVAC.
2. Check if any DTC No. is displayed in the self-diagnosis results.

##### NOTE:

If DTC is displayed along with DTC U1000 or U1010, first diagnose the DTC U1000 or U1010. Refer to [HAC-165. "DTC Logic"](#) or [HAC-166. "DTC Logic"](#).

Is DTC No. "B2661", "B2662" or "B2663" displayed?

- YES >> Perform trouble diagnosis for the upper ventilator door motor. Refer to [HAC-189. "Diagnosis Procedure"](#).
- NO >> GO TO 2.

##### 2. FUNCTION INSPECTION

1. Press the UPPER VENT switch.
2. The UPPER VENT switch indicator is turned ON.

# B2661, B2662, B2663 UPPER VENTILATOR DOOR MOTOR

< DTC/CIRCUIT DIAGNOSIS >

[WITH 7 INCH DISPLAY]

3. Check that the air blown from UPPER VENT does not greatly deviate from the air mix ratio.

Discharge air flow							
Mode position indication	Condition	Air outlet/distribution					
		VENT			FOOT		DEF
		Front	Upper	Rear	Front	Rear	
	DUAL switch: OFF UPPER VENT switch : ON	81%	8%	11%	—	—	—
		41%	10%	17%	24%	8%	—
		12%	12%	16%	27%	10%	23%
		11%	11%	14%	25%	10%	29%
		11%	11%	12%	—	—	66%

JPIIA0509GB

4. Press the UPPER VENT switch again.
5. The UPPER VENT switch indicator is turned OFF.
6. The air blown from UPPER VENT stops.

Does it operate normally?

YES >> INSPECTION END

NO >> Check upper ventilator door motor installation, and repair or replace the malfunctioning parts.

## Diagnosis Procedure

INFOID:000000005514736

### 1.CHECK POWER SUPPLY FOR UPPER VENTILATOR DOOR MOTOR

Check voltage between upper ventilator door motor harness connector and ground.

(+)		(-)	Voltage
Upper ventilator door motor		—	
Connector	Terminal		
M308	1	Ground	Battery voltage

Is the inspection result normal?

YES >> GO TO 2.

NO >> Repair harness or connector.

### 2.CHECK SIGNAL FOR UPPER VENTILATOR DOOR MOTOR

Confirm A/C LAN signal between upper ventilator door motor harness connector and ground using an oscilloscope.

(+)		(-)	Voltage
Upper ventilator door motor		—	
Connector	Terminal		
M308	3	Ground	

SJIA1453J

Is the inspection result normal?

YES >> GO TO 3.

NO >> Repair harness or connector.

# B2661, B2662, B2663 UPPER VENTILATOR DOOR MOTOR

< DTC/CIRCUIT DIAGNOSIS >

[WITH 7 INCH DISPLAY]

## 3. CHECK UPPER VENTILATOR DOOR MOTOR GROUND CIRCUIT

1. Turn ignition switch OFF.
2. Disconnect upper ventilator door motor connector.
3. Check continuity between upper ventilator door motor harness connector and ground.

Upper ventilator door motor		—	Continuity
Connector	Terminal		
M308	2	Ground	Existed

Is the inspection result normal?

- YES >> Replace upper ventilator door motor.  
NO >> Repair harness or connector.

# BLOWER MOTOR

< DTC/CIRCUIT DIAGNOSIS >

[WITH 7 INCH DISPLAY]

## BLOWER MOTOR

### Description

INFOID:000000005514737

### COMPONENT DESCRIPTION

#### Brush-less Motor

The blower motor utilizes a brush-less motor with a rotating magnet. Quietness is improved over previous motors where the brush was the point of contact and the coil rotated.

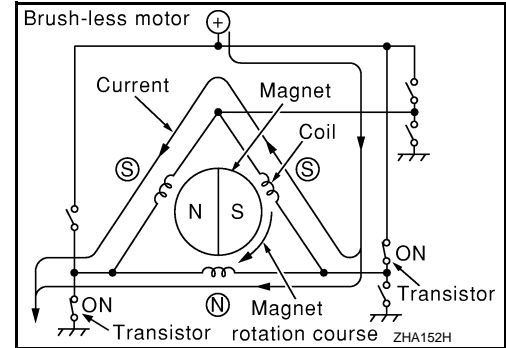

#### Blower Motor Circuit

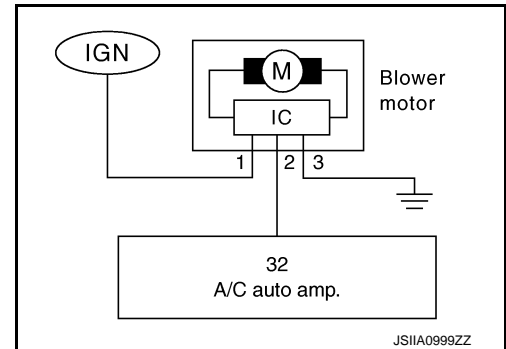

### Component Function Check

INFOID:000000005514738

#### 1. CHECK OPERATION

1. Warm up the engine.
2. Operate the fan control dial. Check that the fan speed and indicator are switched for all fan speeds.

#### Does it operate normally?

- YES >> INSPECTION END  
NO >> Perform trouble diagnosis for the blower motor. Refer to [HAC-191, "Diagnosis Procedure"](#).

### Diagnosis Procedure

INFOID:000000005514739

#### 1. CHECK WITH SELF-DIAGNOSIS FUNCTION OF CONSULT-III

1. Using CONSULT-III, perform "SELF-DIAGNOSIS RESULTS" of HVAC.
2. Check if any DTC No. is displayed in the self-diagnosis results.

#### **NOTE:**

If DTC is displayed along with DTC U1000 or U1010, first diagnose the DTC U1000 or U1010. Refer to [HAC-165, "DTC Logic"](#) or [HAC-166, "DTC Logic"](#).

#### Is any DTC No. displayed?

- YES >> Perform the diagnosis that is applicable to the sensor and actuator. Refer to [HAC-226, "DTC Index"](#).

- NO >> GO TO 2.

#### 2. CHECK WITH ACTIVE TEST OF CONSULT-III

1. Using CONSULT-III, perform "HVAC TEST" "ACTIVE TEST" of HVAC to check each output device. Refer to [HAC-161, "CONSULT-III Function"](#).

#### **NOTE:**

Perform the ACTIVE TEST after starting the engine because the compressor is operated.

# BLOWER MOTOR

< DTC/CIRCUIT DIAGNOSIS >

[WITH 7 INCH DISPLAY]

- Check that the blower motor control signal changes according to each indicator signal.

	Test item						
	MODE 1	MODE 2	MODE 3	MODE 4	MODE 5	MODE 6	MODE 7
Mode door position	VENT1	VENT2	B/L1	B/L2	FOOT	D/F	DEF
Intake door position	REC	REC	20%FRE	20%FRE	FRE	FRE	FRE
Air mix door position (driver & passenger side)	FULL COLD	FULL HOT	FULL COLD	FULL HOT	FULL HOT	FULL HOT	FULL HOT
Blower motor duty ratio	35%	35%	61%	61%	81%	81%	35%
Compressor (Magnet clutch)	ON	ON	ON	ON	OFF	OFF	ON
Upper ventilator door	OPEN	SHUT	OPEN	SHUT	SHUT	SHUT	SHUT

**NOTE:**

Perform the inspection of each output device after starting the engine because the compressor is operated.

Does it operate normally?

- YES >> INSPECTION END  
 NO >> GO TO 3.

### 3.CHECK POWER SUPPLY FOR BLOWER MOTOR

- Disconnect blower motor connector.
- Turn ignition switch ON.
- Check voltage between blower motor harness connector and ground.

(+)		(-)	Voltage
Blower motor		—	
Connector	Terminal		
M98	1	Ground	Battery voltage

Is the inspection result normal?

- YES >> GO TO 4.  
 NO >> GO TO 7.

### 4.CHECK BLOWER MOTOR GROUND CIRCUIT

- Turn ignition switch OFF.
- Check continuity between blower motor harness connector and ground.

Blower motor		—	Continuity
Connector	Terminal		
M98	3	Ground	Existed

Is the inspection result normal?

- YES >> GO TO 5.  
 NO >> Repair harness or connector.

### 5.CHECK BLOWER MOTOR CIRCUIT CONTINUITY

- Disconnect A/C auto amp. connector.
- Check continuity between blower motor harness connector and A/C auto amp. harness connector.

Blower motor		A/C auto amp.		Continuity
Connector	Terminal	Connector	Terminal	
M98	2	M50	32	Existed

Is the inspection result normal?

- YES >> GO TO 6.



# BLOWER MOTOR

< DTC/CIRCUIT DIAGNOSIS >

[WITH 7 INCH DISPLAY]

NO >> Repair harness or connector.

## 6. CHECK A/C AUTO AMP. OUTPUT SIGNAL

1. Reconnect blower motor connector and A/C auto amp. connector.
2. Turn ignition switch ON.
3. Set MODE switch to the VENT position.
4. Check the output waveform between blower motor harness connector and ground using an oscilloscope, while varying the fan speed from 1 to 7.

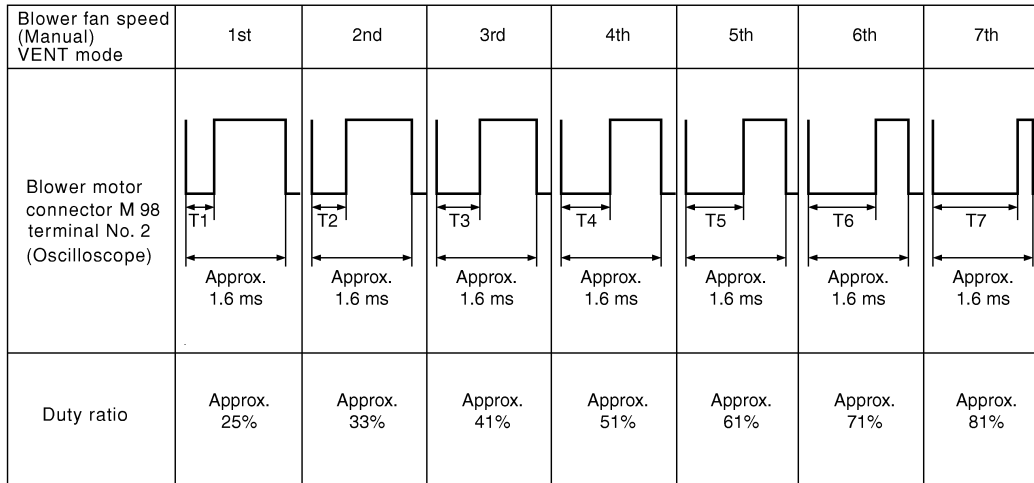

NOTE: Duty ratio =  $\frac{T_x}{\text{Approx. } 1.6 \text{ ms}} \times 100 (\%)$

JPIIA0616GB

Is the inspection result normal?

- YES >> Replace the blower motor.  
 NO >> Replace the A/C auto amp.

## 7. CHECK POWER VOLTAGE OF BLOWER RELAY

1. Turn the ignition switch OFF.
2. Remove the blower relay. Refer to [PG-113, "Fuse, Connector and Terminal Arrangement"](#).
3. Turn the ignition switch ON.
4. Check the voltage between blower relay fuse block side terminal and ground. Refer to [PG-113, "Fuse, Connector and Terminal Arrangement"](#) for relay terminal assignment.

(+)	(-)	Voltage
Blower relay	—	
1	Ground	Battery voltage
3		

Is the inspection result normal?

- YES >> GO TO 8.  
 NO >> Inspection the power supply circuit. Refer to [PG-67, "Wiring Diagram - IGNITION POWER SUPPLY -"](#).

## 8. CHECK BLOWER RELAY

1. Turn the ignition switch OFF.
2. Install the blower relay. Refer to [PG-113, "Fuse, Connector and Terminal Arrangement"](#).
3. Turn the ignition switch ON.
4. Check the operating sound of blower relay.

Is the inspection result normal?

- YES >> GO TO 9.  
 NO >> Replace the blower relay.

## 9. CHECK FUSE

Check 15A fuses (Nos. 21 and 22).

**NOTE:**

A  
B  
C  
D  
E  
F  
G  
H

HAC

J  
K  
L  
M

N  
O  
P

# BLOWER MOTOR

< DTC/CIRCUIT DIAGNOSIS >

[WITH 7 INCH DISPLAY]

Refer to [PG-113, "Fuse, Connector and Terminal Arrangement"](#) for fuse location.

Is the inspection result normal?

YES >> Repair the harnesses or connectors.

NO >> Replace the fuse after repairing the applicable circuit.

## Component Inspection

INFOID:000000005514740

### 1. CHECK BLOWER MOTOR

1. Remove the blower motor. Refer to [VTL-95, "Exploded View"](#).

2. Check that the blower motor rotates smoothly.

Is the inspection result normal?

YES >> INSPECTION END

NO >> Replace blower motor.

## MAGNET CLUTCH

### Description

INFOID:000000005514741

The magnet clutch drives the compressor, by an IPDM E/R signal.

### Component Function Check

INFOID:000000005514742

#### 1. FUNCTION INSPECTION

1. Press AUTO switch.
2. "AUTO" is indicated on the display.
3. Press the A/C switch.
4. Check that the indicator of the A/C switch turns on. Check visually and by sound that the compressor is operating (the discharge air temperature or fan speed varies depending on the ambient temperature, in-vehicle temperature, and temperature setting).
5. Press the A/C switch again.
6. Check that the indicator of the A/C switch turns OFF. Check visually and by sound that the compressor stops.

#### Does it operate normally?

YES >> INSPECTION END

NO >> Perform trouble diagnosis for the compressor. Refer to [HAC-195, "Diagnosis Procedure"](#).

### Diagnosis Procedure

INFOID:000000005514743

#### 1. INSPECTION IN AUTO ACTIVE TEST MODE

Perform "AUTO ACTIVE TEST". Refer to [PCS-10, "Diagnosis Description"](#).

#### Does it operate normally?

YES >> GO TO 5.

NO >> GO TO 2.

#### 2. CHECK MAGNET CLUTCH

1. Turn the ignition switch OFF.
2. Disconnect the magnet clutch connector.
3. Directly apply the battery voltage to the magnet clutch. Check for operation visually and by sound.

#### Does it operate normally?

YES >> GO TO 3.

NO >> Replace the compressor.

#### 3. CHECK MAGNET CLUTCH CIRCUIT CONTINUITY

1. Turn the ignition switch OFF.
2. Disconnect IPDM E/R connector.
3. Check continuity between magnet clutch harness connector and IPDM E/R harness connector.

IPDM E/R		Compressor		Continuity
Connector	Terminal	Connector	Terminal	
F12	48	F18	1	Existed

#### Is the inspection result normal?

YES >> GO TO 4.

NO >> Repair harness or connector.

#### 4. CHECK FUSE

Check 10A fuse (No. 49).

#### **NOTE:**

Refer to [PG-115, "Fuse, Connector and Terminal Arrangement"](#) for fuse location.

#### Is the inspection result normal?

YES >> Replace IPDM E/R.

# MAGNET CLUTCH

[WITH 7 INCH DISPLAY]

< DTC/CIRCUIT DIAGNOSIS >

NO >> Replace the fuse after repairing the applicable circuit.

## 5. CHECK WITH SELF-DIAGNOSIS FUNCTION OF CONSULT-III

1. Using CONSULT-III, perform "SELF-DIAGNOSIS RESULTS" of HVAC.
2. Check if any DTC No. is displayed in the self-diagnosis results.

### NOTE:

If DTC is displayed along with DTC U1000 or U1010, first diagnose the DTC U1000 or U1010. Refer to [HAC-165. "DTC Logic"](#) or [HAC-166. "DTC Logic"](#).

Is any DTC No. displayed?

YES >> Perform the diagnosis that is applicable to the sensor and actuator. Refer to [HAC-226. "DTC Index"](#).

NO >> GO TO 6.

## 6. CHECK A/C AUTO AMP. INPUT SIGNAL

Using CONSULT-III, check "On/Off" of "COMP REQ SIG" and "FAN REQ SIG" in "DATA MONITOR" of HVAC. Refer to [HAC-161. "CONSULT-III Function"](#).

A/C SWITCH ON	: COMP REQ SIG On
A/C SWITCH OFF	: COMP REQ SIG Off
FAN CONTROL DIAL ON	: FAN REQ SIG On
FAN CONTROL DIAL OFF	: FAN REQ SIG Off

Is the inspection result normal?

YES >> GO TO 7.

NO >> Replace A/C auto amp.

## 7. CHECK REFRIGERANT PRESSURE SENSOR

Check refrigerant pressure sensor. Refer to [EC-457. "Diagnosis Procedure"](#).

Is the inspection result normal?

YES >> INSPECTION END

NO >> Repair or replace malfunctioning parts.

# POWER SUPPLY AND GROUND CIRCUIT

< DTC/CIRCUIT DIAGNOSIS >

[WITH 7 INCH DISPLAY]

## POWER SUPPLY AND GROUND CIRCUIT

### A/C AUTO AMP.

#### A/C AUTO AMP. : Description

INFOID:000000005514744

#### COMPONENT DESCRIPTION

A/C Auto Amp. (Air Conditioner Automatic Amplifier)

The A/C auto amp. (1) has a built-in microcomputer that processes information sent from various sensors needed for air conditioner operation. The air mix door motor(s), the mode door motor, the intake door motor, the upper ventilator door motor, the blower motor and the compressor are then controlled.

When the various switches and temperature control dial are operated, data is input to the A/C auto amp. from the AV control unit using CAN communication.

The A/C auto amp. is operated with control mechanisms. Signals from various switches and Potentio Temperature Control (PTC) are directly entered into the A/C auto amp.

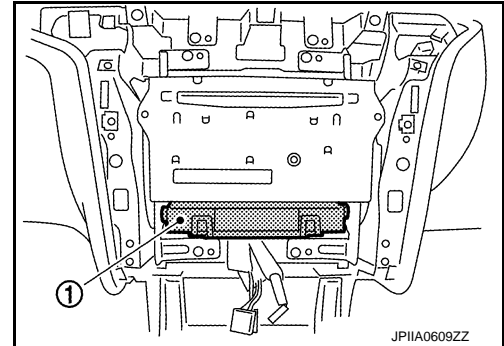

#### Power Supply and Ground Circuit for A/C Auto Amp.

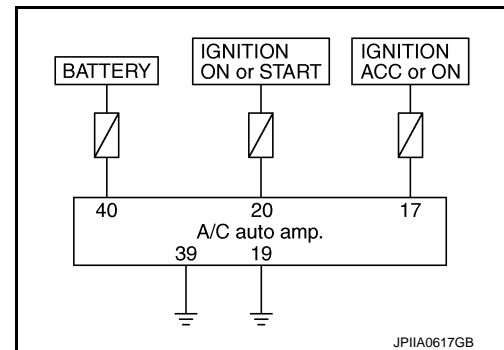

#### A/C AUTO AMP. : Component Function Check

INFOID:000000005514745

##### 1. CHECK OPERATION

1. Press the AUTO switch, and then check that "AUTO" is shown on the display.
2. Operate the temperature control dial (driver side). Check that the fan speed or outlet changes. (The discharge air temperature or fan speed varies depending on the ambient temperature, in-vehicle temperature, and temperature setting.)

##### Does it operate normally?

YES >> INSPECTION END

NO >> Perform trouble diagnosis for the A/C system. Refer to [HAC-197. "A/C AUTO AMP. : Diagnosis Procedure"](#).

#### A/C AUTO AMP. : Diagnosis Procedure

INFOID:000000005514746

##### 1. INSPECTION BY FAIL-SAFE FUNCTION

1. Turn the ignition switch ON.
2. After approximately 30 seconds, check that the air conditioner is operated by the fail-safe function (the operation display of air conditioner is not performed). Refer to [HAC-225. "Fail-Safe"](#).

##### Is the fail-safe function operated?

YES >> GO TO 5.

NO >> GO TO 2.

##### 2. CHECK A/C AUTO AMP. POWER SUPPLY CIRCUIT

1. Disconnect the A/C auto amp. connector.
2. Check voltage between A/C auto amp. harness connector and ground.

# POWER SUPPLY AND GROUND CIRCUIT

< DTC/CIRCUIT DIAGNOSIS >

[WITH 7 INCH DISPLAY]

(+) A/C auto amp.		(-)	Voltage		
A/C auto amp.		—	Ignition switch position		
Connector	Terminal		OFF	ACC	ON
M50	17	Ground	Approx. 0 V	Battery voltage	Battery voltage
	20		Approx. 0 V	Approx. 0 V	Battery voltage
	40		Battery voltage	Battery voltage	Battery voltage

Is the inspection result normal?

YES >> GO TO 4.  
NO >> GO TO 3.

## 3.CHECK FUSE

Check 10A fuses [Nos. 3, 6 and 19, located in the fuse block (J/B)].

**NOTE:**

Refer to [PG-113, "Fuse, Connector and Terminal Arrangement"](#).

Is the inspection result normal?

YES >> Repair the harnesses or connectors.  
NO >> Replace the fuse after repairing the applicable circuit.

## 4.CHECK A/C AUTO AMP. CIRCUIT CONTINUITY

1. Turn ignition switch OFF.
2. Check continuity between A/C auto amp. harness connector and ground.

A/C auto amp.		—	Continuity
Connector	Terminal	Ground	Existed
M50	19		
	39		

Is the inspection result normal?

YES >> GO TO 5.  
NO >> Repair the harnesses or connectors.

## 5.CHECK PRESET SWITCH

Check the preset switch. Refer to [AV-520, "Symptom Table"](#) (bose audio without navigation) or [AV-773, "Symptom Table"](#) (bose audio with navigation).

Is the inspection result normal?

YES >> Replace the A/C auto amp.  
NO >> Repair or replace parts according to the inspection results.

# ECU DIAGNOSIS INFORMATION

## ECM

### Reference Value

INFOID:000000005683189

#### VALUES ON THE DIAGNOSIS TOOL

##### Remarks:

- Specification data are reference values.
- Specification data are output/input values which are detected or supplied by the ECM at the connector.
- \* Specification data may not be directly related to their components signals/values/operations.

I.e. Adjust ignition timing with a timing light before monitoring IGN TIMING, because the monitor may show the specification data in spite of the ignition timing not being adjusted to the specification data. This IGN TIMING monitors the data calculated by the ECM according to the signals input from the camshaft position sensor and other ignition timing related sensors.

Monitor Item	Condition		Values/Status
ENG SPEED	Run engine and compare CONSULT-III value with the tachometer indication.		Almost the same speed as the tachometer indication.
MAS A/F SE-B1	See <a href="#">EC-126, "Description"</a> .		
B/FUEL SCHDL	See <a href="#">EC-126, "Description"</a> .		
A/F ALPHA-B1	See <a href="#">EC-126, "Description"</a> .		
A/F ALPHA-B2	See <a href="#">EC-126, "Description"</a> .		
COOLAN TEMP/S	• Engine: After warming up		More than 70°C (158°F)
A/F SEN1 (B1)	• Engine: After warming up	Maintaining engine speed at 2,000 rpm	Fluctuates around 2.2 V
A/F SEN1 (B2)	• Engine: After warming up	Maintaining engine speed at 2,000 rpm	Fluctuates around 2.2 V
HO2S2 (B1)	<ul style="list-style-type: none"> <li>• Revving engine from idle to 3,000 rpm quickly after the following conditions are met.</li> <li>- Engine: After warming up</li> <li>- After keeping engine speed between 3,500 and 4,000 rpm for 1 minute and at idle for 1 minute under no load</li> </ul>		0 - 0.3 V ↔ Approx. 0.6 - 1.0 V
HO2S2 (B2)	<ul style="list-style-type: none"> <li>• Revving engine from idle to 3,000 rpm quickly after the following conditions are met.</li> <li>- Engine: After warming up</li> <li>- After keeping engine speed between 3,500 and 4,000 rpm for 1 minute and at idle for 1 minute under no load</li> </ul>		0 - 0.3 V ↔ Approx. 0.6 - 1.0 V
HO2S2 MNTR (B1)	<ul style="list-style-type: none"> <li>• Revving engine from idle to 3,000 rpm quickly after the following conditions are met.</li> <li>- Engine: After warming up</li> <li>- After keeping engine speed between 3,500 and 4,000 rpm for 1 minute and at idle for 1 minute under no load</li> </ul>		LEAN ↔ RICH
HO2S2 MNTR (B2)	<ul style="list-style-type: none"> <li>• Revving engine from idle to 3,000 rpm quickly after the following conditions are met.</li> <li>- Engine: After warming up</li> <li>- After keeping engine speed between 3,500 and 4,000 rpm for 1 minute and at idle for 1 minute under no load</li> </ul>		LEAN ↔ RICH
VHCL SPEED SE	• Turn drive wheels and compare CONSULT-III value with the speedometer indication.		Almost the same speed as speedometer indication
BATTERY VOLT	• Ignition switch: ON (Engine stopped)		11 - 14 V
ACCEL SEN 1	• Ignition switch: ON (Engine stopped)	Accelerator pedal: Fully released	0.5 - 1.0 V
		Accelerator pedal: Fully depressed	4.2 - 4.8 V
ACCEL SEN 2*1	• Ignition switch: ON (Engine stopped)	Accelerator pedal: Fully released	0.5 - 1.0 V
		Accelerator pedal: Fully depressed	4.2 - 4.8 V

# ECM

## < ECU DIAGNOSIS INFORMATION >

[WITH 7 INCH DISPLAY]

Monitor Item	Condition	Values/Status
TP SEN 1-B1	• Ignition switch: ON (Engine stopped) • Selector lever: D position	Accelerator pedal: Fully released More than 0.36 V
		Accelerator pedal: Fully depressed Less than 4.75 V
TP SEN 2-B1*1	• Ignition switch: ON (Engine stopped) • Selector lever: D position	Accelerator pedal: Fully released More than 0.36 V
		Accelerator pedal: Fully depressed Less than 4.75 V
FUEL T/TMP SE	• Ignition switch: ON	Indicates fuel tank temperature
INT/A TEMP SE	• Ignition switch: ON	Indicates intake air temperature
EVAP SYS PRES	• Ignition switch: ON	Approx. 1.8 - 4.8 V
FUEL LEVEL SE	• Ignition switch: ON	Depending on fuel level of fuel tank
START SIGNAL	• Ignition switch: ON → START → ON	OFF → ON → OFF
CLSD THL POS	• Ignition switch: ON (Engine stopped)	Accelerator pedal: Fully released ON
		Accelerator pedal: Slightly depressed OFF
AIR COND SIG	• Engine: After warming up, idle the engine	Air conditioner switch: OFF OFF
		Air conditioner switch: ON (Compressor operates.) ON
P/N POSI SW	• Ignition switch: ON	Selector lever: P or N position ON
		Selector lever: Except above position OFF
PW/ST SIGNAL	• Engine: After warming up, idle the engine	Steering wheel: Not being turned OFF
		Steering wheel: Being turned ON
LOAD SIGNAL	• Ignition switch: ON	Rear window defogger switch: ON and/or Lighting switch: 2nd position ON
		Rear window defogger switch and lighting switch: OFF OFF
IGNITION SW	• Ignition switch: ON → OFF → ON	ON → OFF → ON
HEATER FAN SW	• Engine: After warming up, idle the engine	Heater fan switch: ON ON
		Heater fan switch: OFF OFF
BRAKE SW	• Ignition switch: ON	Brake pedal: Fully released OFF
		Brake pedal: Slightly depressed ON
INJ PULSE-B1	• Engine: After warming up • Selector lever: P or N position • Air conditioner switch: OFF • No load	Idle 2.0 - 3.0 msec
		2,000 rpm 1.9 - 2.9 msec
INJ PULSE-B2	• Engine: After warming up • Selector lever: P or N position • Air conditioner switch: OFF • No load	Idle 2.0 - 3.0 msec
		2,000 rpm 1.9 - 2.9 msec
IGN TIMING	• Engine: After warming up • Selector lever: P or N position • Air conditioner switch: OFF • No load	Idle 7 - 17°BTDC
		2,000 rpm 25 - 45°BTDC
CAL/LD VALUE	• Engine: After warming up • Selector lever: P or N position • Air conditioner switch: OFF • No load	Idle 5 - 35%
		2,500 rpm 5 - 35%
MASS AIRFLOW	• Engine: After warming up • Selector lever: P or N position • Air conditioner switch: OFF • No load	Idle 2.0 - 6.0 g·m/s
		2,500 rpm 7.0 - 20.0 g·m/s



# ECM

< ECU DIAGNOSIS INFORMATION >

[WITH 7 INCH DISPLAY]

Monitor Item	Condition		Values/Status
PURG VOL C/V	<ul style="list-style-type: none"> <li>Engine: After warming up</li> <li>Selector lever: P or N position</li> <li>Air conditioner switch: OFF</li> <li>No load</li> </ul>	Idle (Accelerator pedal: Not depressed even slightly, after engine starting.)	0%
		2,000 rpm	—
INT/V TIM (B1)	<ul style="list-style-type: none"> <li>Engine: After warming up</li> <li>Selector lever: P or N position</li> <li>Air conditioner switch: OFF</li> <li>No load</li> </ul>	Idle	-5 - 5°C
		2,000 rpm	Approx. 0 - 30°C
INT/V TIM (B2)	<ul style="list-style-type: none"> <li>Engine: After warming up</li> <li>Selector lever: P or N position</li> <li>Air conditioner switch: OFF</li> <li>No load</li> </ul>	Idle	-5 - 5°C
		2,000 rpm	Approx. 0 - 30°C
INT/V SOL (B1)	<ul style="list-style-type: none"> <li>Engine: After warming up</li> <li>Selector lever: P or N position</li> <li>Air conditioner switch: OFF</li> <li>No load</li> </ul>	Idle	0 - 2%
		2,000 rpm	Approx. 0 - 50%
INT/V SOL (B2)	<ul style="list-style-type: none"> <li>Engine: After warming up</li> <li>Selector lever: P or N position</li> <li>Air conditioner switch: OFF</li> <li>No load</li> </ul>	Idle	0 - 2%
		2,000 rpm	Approx. 0 - 50%
VIAS S/V-1	<ul style="list-style-type: none"> <li>Engine: After warming up</li> <li>Selector lever: P or N position</li> <li>Air conditioner switch: OFF</li> <li>No load</li> </ul>	When revving engine up to 5,000 rpm quickly	OFF → ON → OFF
VIAS S/V-2	<ul style="list-style-type: none"> <li>Engine: After warming up</li> <li>Selector lever: P or N position</li> <li>Air conditioner switch: OFF</li> <li>No load</li> </ul>	When revving engine up to 5,000 rpm quickly	OFF → ON → OFF
AIR COND RLY	<ul style="list-style-type: none"> <li>Engine: After warming up, idle the engine</li> </ul>	Air conditioner switch: OFF	OFF
		Air conditioner switch: ON (Compressor operates)	ON
ENGINE MOUNT	<ul style="list-style-type: none"> <li>Engine: After warming up</li> </ul>	Below 950 rpm	IDLE
		Above 950 rpm	TRVL
FUEL PUMP RLY	<ul style="list-style-type: none"> <li>For 1 second after turning ignition switch: ON</li> <li>Engine running or cranking</li> </ul>		ON
		<ul style="list-style-type: none"> <li>Except above</li> </ul>	OFF
VENT CONT/V	<ul style="list-style-type: none"> <li>Ignition switch: ON</li> </ul>		OFF
THRTL RELAY	<ul style="list-style-type: none"> <li>Ignition switch: ON</li> </ul>		ON
COOLING FAN	<ul style="list-style-type: none"> <li>Engine: After warming up, idle the engine</li> <li>Air conditioner switch: OFF</li> </ul>	Engine coolant temperature: 97°C (206°F) or less	OFF
		Engine coolant temperature: Between 98°C (208°F) and 99°C (210°F)	LOW
		Engine coolant temperature: Between 100°C (212°F) and 104°C (219°F)	MID
		Engine coolant temperature: 105°C (221°F) or more	HI
HO2S2 HTR (B1)	<ul style="list-style-type: none"> <li>Engine speed: Below 3,600 rpm after the following conditions are met.                             <ul style="list-style-type: none"> <li>Engine: After warming up</li> <li>Keeping the engine speed between 3,500 and 4,000 rpm for 1 minute and at idle for 1 minute under no load</li> </ul> </li> <li>Engine speed: Above 3,600 rpm</li> </ul>		ON
			OFF

A  
B  
C  
D  
E  
F  
G  
H  
J  
K  
L  
M  
N  
O  
P

HAC

# ECM

< ECU DIAGNOSIS INFORMATION >

[WITH 7 INCH DISPLAY]

Monitor Item	Condition		Values/Status
HO2S2 HTR (B2)	<ul style="list-style-type: none"> <li>Engine speed: Below 3,600 rpm after the following conditions are met.                             <ul style="list-style-type: none"> <li>Engine: After warming up</li> <li>Keeping the engine speed between 3,500 and 4,000 rpm for 1 minute and at idle for 1 minute under no load</li> </ul> </li> </ul>		ON
	<ul style="list-style-type: none"> <li>Engine speed: Above 3,600 rpm</li> </ul>		OFF
I/P PULLY SPD	<ul style="list-style-type: none"> <li>Vehicle speed: More than 20 km/h (12 MPH)</li> </ul>		Almost the same speed as the tachometer indication
VEHICLE SPEED	<ul style="list-style-type: none"> <li>Turn drive wheels and compare CONSULT-III value with the speedometer indication.</li> </ul>		Almost the same speed as the speedometer indication
IDL A/V LEARN	<ul style="list-style-type: none"> <li>Engine: Running</li> </ul>	Idle air volume learning has not been performed yet.	YET
		Idle air volume learning has already been performed successfully.	CMPLT
ENG OIL TEMP	<ul style="list-style-type: none"> <li>Engine: After warming up</li> </ul>		More than 70°C (158°F)
TRVL AFTER MIL	<ul style="list-style-type: none"> <li>Ignition switch: ON</li> </ul>	Vehicle has traveled after MIL has illuminated.	0 - 65,535 km (0 - 40,723 miles)
A/F S1 HTR (B1)	<ul style="list-style-type: none"> <li>Engine: After warming up, idle the engine (More than 140 seconds after starting engine)</li> </ul>		4 - 100%
A/F S1 HTR (B2)	<ul style="list-style-type: none"> <li>Engine: After warming up, idle the engine (More than 140 seconds after starting engine)</li> </ul>		4 - 100%
AC PRESS SEN	<ul style="list-style-type: none"> <li>Engine: Idle</li> <li>Both A/C switch and blower fan switch: ON (Compressor operates)</li> </ul>		1.0 - 4.0 V
VHCL SPEED SE	<ul style="list-style-type: none"> <li>Turn drive wheels and compare CONSULT-III value with the speedometer indication.</li> </ul>		Almost the same speed as the speedometer indication
SET VHCL SPD	<ul style="list-style-type: none"> <li>Engine: Running</li> </ul>	ASCD: Operating	The preset vehicle speed is displayed
MAIN SW	<ul style="list-style-type: none"> <li>Ignition switch: ON</li> </ul>	MAIN switch: Pressed	ON
		MAIN switch: Released	OFF
CANCEL SW	<ul style="list-style-type: none"> <li>Ignition switch: ON</li> </ul>	CANCEL switch: Pressed	ON
		CANCEL switch: Released	OFF
RESUME/ACC SW	<ul style="list-style-type: none"> <li>Ignition switch: ON</li> </ul>	RESUME/ACCELERATE switch: Pressed	ON
		RESUME/ACCELERATE switch: Released	OFF
SET SW	<ul style="list-style-type: none"> <li>Ignition switch: ON</li> </ul>	SET/COAST switch: Pressed	ON
		SET/COAST switch: Released	OFF
BRAKE SW1 (ASCD brake switch)	<ul style="list-style-type: none"> <li>Ignition switch: ON</li> </ul>	Brake pedal: Fully released	ON
		Brake pedal: Slightly depressed	OFF
BRAKE SW2 (Stop lamp switch)	<ul style="list-style-type: none"> <li>Ignition switch: ON</li> </ul>	Brake pedal: Fully released	OFF
		Brake pedal: Slightly depressed	ON
VHCL SPD CUT	<ul style="list-style-type: none"> <li>Ignition switch: ON</li> </ul>		NON
LO SPEED CUT	<ul style="list-style-type: none"> <li>Ignition switch: ON</li> </ul>		NON
AT OD MONITOR	<ul style="list-style-type: none"> <li>Ignition switch: ON</li> </ul>		OFF
AT OD CANCEL	<ul style="list-style-type: none"> <li>Ignition switch: ON</li> </ul>		OFF
CRUISE LAMP	<ul style="list-style-type: none"> <li>Ignition switch: ON</li> </ul>	MAIN switch: Pressed at the 1st time → at the 2nd time	ON → OFF
SET LAMP	<ul style="list-style-type: none"> <li>MAIN switch: ON</li> <li>When vehicle speed is between 40 km/h (25 MPH) and 144 km/h (89 MPH)</li> </ul>	ASCD: Operating	ON
		ASCD: Not operating	OFF

# ECM

## < ECU DIAGNOSIS INFORMATION >

[WITH 7 INCH DISPLAY]

Monitor Item	Condition	Values/Status
ALT DUTY	• Engine: Idle	0 - 80%
A/F ADJ-B1	• Engine: Running	-0.330 - 0.330
A/F ADJ-B2	• Engine: Running	-0.330 - 0.330
BAT CUR SEN	<ul style="list-style-type: none"> <li>• Engine speed: Idle</li> <li>• Battery: Fully charged*2</li> <li>• Selector lever: P or N position</li> <li>• Air conditioner switch: OFF</li> <li>• No load</li> </ul>	Approx. 2,600 - 3,500 mV
ALT DUTY SIG	• Power generation voltage variable control: Operating	ON
	• Power generation voltage variable control: Not operating	OFF
HO2 S2 DIAG1 (B1)	DTC P0139 self-diagnosis (delayed response) is incomplete.	INCMPT
	DTC P0139 self-diagnosis (delayed response) is complete.	CMPLT
HO2 S2 DIAG1 (B2)	DTC P0159 self-diagnosis (delayed response) is incomplete.	INCMPT
	DTC P0159 self-diagnosis (delayed response) is complete.	CMPLT
HO2 S2 DIAG2 (B1)	DTC P0139 self-diagnosis (slow response) is incomplete.	INCMPT
	DTC P0139 self-diagnosis (slow response) is complete.	CMPLT
HO2 S2 DIAG2 (B2)	DTC P0159 self-diagnosis (slow response) is incomplete.	INCMPT
	DTC P0159 self-diagnosis (slow response) is complete.	CMPLT

\*1: Accelerator pedal position sensor 2 signal and throttle position sensor 2 signal are converted by ECM internally. Thus, they differ from ECM terminals voltage signal.

\*2: Before measuring the terminal voltage, confirm that the battery is fully charged. Refer to [PG-3, "How to Handle Battery"](#).

### TERMINAL LAYOUT

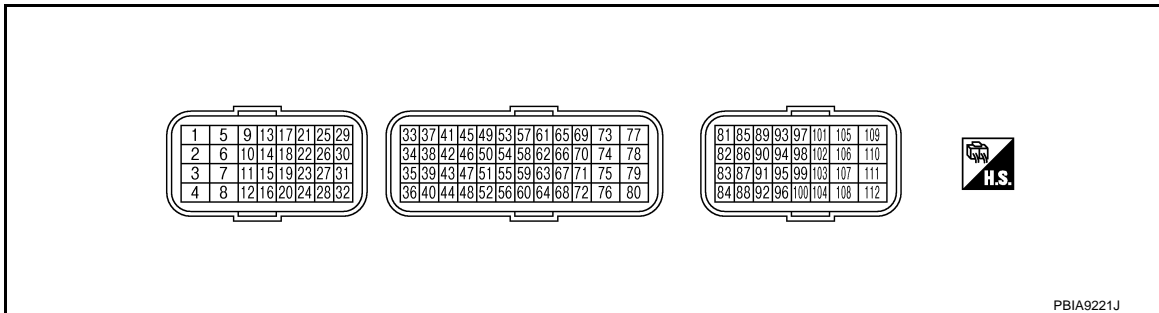

### PHYSICAL VALUES

**NOTE:**

- ECM is located in the engine room left side near battery.
- Specification data are reference values.
- Pulse signal is measured by CONSULT-III.

# ECM

< ECU DIAGNOSIS INFORMATION >

[WITH 7 INCH DISPLAY]

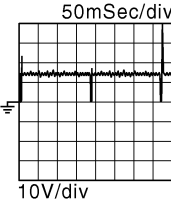
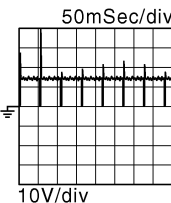
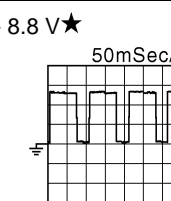
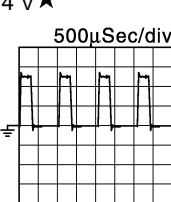
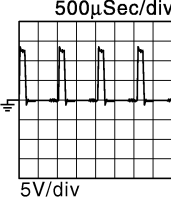
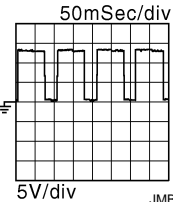
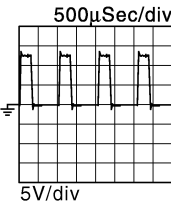
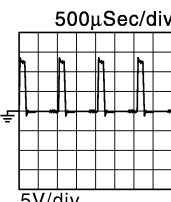
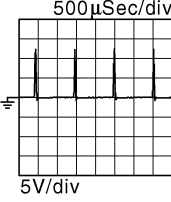
Terminal No.		Description		Condition	Value (Approx.)
+	-	Signal name	Input/Output		
1 (P/B)	112 (B)	Fuel injector No. 6	Output	[Engine is running] • Warm-up condition • Idle speed <b>NOTE:</b> The pulse cycle changes depending on rpm at idle	BATTERY VOLTAGE (11 - 14 V)★ 
3 (L/W)		Fuel injector No. 5			BATTERY VOLTAGE (11 - 14 V)★ 
29 (LG/R)		Fuel injector No. 4			BATTERY VOLTAGE (11 - 14 V)★ 
30 (R/Y)		Fuel injector No. 3			BATTERY VOLTAGE (11 - 14 V)★ 
31 (R/W)		Fuel injector No. 2			BATTERY VOLTAGE (11 - 14 V)★ 
32 (R/B)	Fuel injector No. 1				
2 (G/W)	112 (B)	Throttle control motor power supply	Input	[Ignition switch: ON]	BATTERY VOLTAGE (11 - 14 V)
4 (BR/Y)	112 (B)	A/F sensor 1 heater (bank 1)	Output	[Engine is running] • Warm-up condition • Idle speed (More than 140 seconds after starting engine)	2.9 - 8.8 V★ 
5 (L)	112 (B)	Throttle control motor (Open)	Output	[Ignition switch: ON] • Engine stopped • Selector lever: D position • Accelerator pedal: Fully depressed	0 - 14 V★ 
				[Ignition switch: ON] • Engine stopped • Selector lever: D position • Accelerator pedal: Fully released	0 - 14 V★ 
6 (P)	112 (B)	Throttle control motor (Close)	Output	[Ignition switch: ON] • Engine stopped • Selector lever: D position • Accelerator pedal: Fully released	0 - 14 V★ 

# ECM

< ECU DIAGNOSIS INFORMATION >

[WITH 7 INCH DISPLAY]

Terminal No.		Description		Condition	Value (Approx.)
+	—	Signal name	Input/Output		
8 (SB)	112 (B)	A/F sensor 1 heater (bank 2)	Output	[Engine is running] • Warm-up condition • Idle speed (More than 140 seconds after starting engine)	2.9 - 8.8 V★ 
9 (L/B) 10 (G/R) 11 (Y/R) 18 (GR/R) 19 (P) 21 (W)	112 (B)	Ignition signal No. 3 Ignition signal No. 2 Ignition signal No. 1 Ignition signal No. 6 Ignition signal No. 5 Ignition signal No. 4	Output	[Engine is running] • Warm-up condition • Idle speed <b>NOTE:</b> The pulse cycle changes depending on rpm at idle	0 - 0.2 V★ 
12 (B)	—	ECM ground	—	—	—
13 (P/B)	112 (B)	Heated oxygen sensor 2 heater (bank 1)	Output	[Engine is running] • Engine speed: Below 3,600 rpm after the following conditions are met - Engine: after warming up - Keeping the engine speed between 3,500 and 4,000 rpm for 1 minute and at idle for 1 minute under no load	10 V★ 
				[Ignition switch: ON] • Engine stopped [Engine is running] • Engine speed: Above 3,600 rpm	BATTERY VOLTAGE (11 - 14 V)
14 (GR)	112 (B)	Fuel pump relay	Output	[Ignition switch: ON] • For 1 second after turning ignition switch ON [Engine is running]	0 - 1.5 V
				[Ignition switch: ON] • More than 1 second after turning ignition switch ON	BATTERY VOLTAGE (11 - 14 V)
15 (O)	112 (B)	Throttle control motor relay	Output	[Ignition switch: ON → OFF] [Ignition switch: ON]	0 - 1.0 V → BATTERY VOLTAGE (11 - 14 V) → 0 V 0 - 1.0 V
16 (B/Y)	—	ECM ground	—	—	—

A  
B  
C  
D  
E  
F  
G  
H  
HAC

J  
K  
L  
M  
N  
O  
P

# ECM

< ECU DIAGNOSIS INFORMATION >

[WITH 7 INCH DISPLAY]

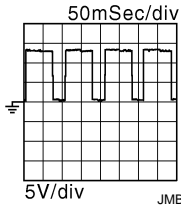
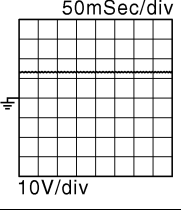
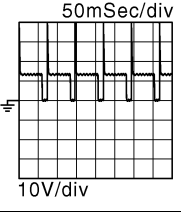
Terminal No.		Description		Condition	Value (Approx.)
+	-	Signal name	Input/Output		
17 (R)	112 (B)	Heated oxygen sensor 2 heater (bank 2)	Output	[Engine is running] <ul style="list-style-type: none"> <li>• Engine speed: Below 3,600 rpm after the following conditions are met</li> <li>- Engine: after warming up</li> <li>- Keeping the engine speed between 3,500 and 4,000 rpm for 1 minute and at idle for 1 minute under no load</li> </ul>	10 V★ 
				[Ignition switch: ON] <ul style="list-style-type: none"> <li>• Engine stopped</li> <li>[Engine is running]</li> <li>• Engine speed: Above 3,600 rpm</li> </ul>	BATTERY VOLTAGE (11 - 14 V)
24 (W/B)	112 (B)	ECM relay (Self shut-off)	Output	[Engine is running] <ul style="list-style-type: none"> <li>[Ignition switch: OFF]</li> <li>• A few seconds after turning ignition switch OFF</li> </ul>	0 - 1.5 V
				[Ignition switch: OFF] <ul style="list-style-type: none"> <li>• More than a few seconds after turning ignition switch OFF</li> </ul>	BATTERY VOLTAGE (11 - 14 V)
25 (P/L)	112 (B)	EVAP canister purge volume control solenoid valve	Output	[Engine is running] <ul style="list-style-type: none"> <li>• Idle speed</li> <li>• Accelerator pedal: Not depressed even slightly, after engine starting</li> </ul>	BATTERY VOLTAGE (11 - 14 V)★ 
				[Engine is running] <ul style="list-style-type: none"> <li>• Engine speed: approximately 2,000 rpm (More than 100 seconds after starting engine)</li> </ul>	BATTERY VOLTAGE (11 - 14 V)★ 
26 (GR/B)	112 (B)	VIAS control solenoid valve 2	Output	[Engine is running] <ul style="list-style-type: none"> <li>• Warm-up condition</li> <li>• Idle speed</li> </ul>	BATTERY VOLTAGE (11 - 14 V)
				[Engine is running] <ul style="list-style-type: none"> <li>• Warm-up condition</li> <li>• When revving engine up to 5,000 rpm quickly</li> </ul>	BATTERY VOLTAGE (11 - 14 V) ↓ 0 - 1.0 V ↓ BATTERY VOLTAGE (11 - 14 V)
27 (V)	112 (B)	VIAS control solenoid valve 1	Output	[Engine is running] <ul style="list-style-type: none"> <li>• Warm-up condition</li> <li>• Idle speed</li> </ul>	BATTERY VOLTAGE (11 - 14 V)
				[Engine is running] <ul style="list-style-type: none"> <li>• Warm-up condition</li> <li>• When revving engine up to 5,000 rpm quickly</li> </ul>	BATTERY VOLTAGE (11 - 14 V) ↓ 0 - 1.0 V ↓ BATTERY VOLTAGE (11 - 14 V)

# ECM

< ECU DIAGNOSIS INFORMATION >

[WITH 7 INCH DISPLAY]

Terminal No.		Description		Condition	Value (Approx.)
+	—	Signal name	Input/Output		
28 (BR/W)	112 (B)	Electronic controlled engine mount control solenoid valve	Output	[Engine is running] • Idle speed	0 - 1.0 V
				[Engine is running] • Engine speed: More than 950 rpm	BATTERY VOLTAGE (11 - 14 V)
33 (W)	112 (B)	Heated oxygen sensor 2 (bank 1)	Input	[Engine is running] • Revving engine from idle to 3,000 rpm quickly after the following conditions are met - Engine: after warming up - Keeping the engine speed between 3,500 and 4,000 rpm for 1 minute and at idle for 1 minute under no load	0 - 1.0 V
34 (W/L)	112 (B)	Heated oxygen sensor 2 (bank 2)	Input	[Engine is running] • Revving engine from idle to 3,000 rpm quickly after the following conditions are met - Engine: after warming up - Keeping the engine speed between 3,500 and 4,000 rpm for 1 minute and at idle for 1 minute under no load	0 - 1.0 V
35 (B)	—	Sensor ground (Heated oxygen sensor 2)	—	—	—
36 (B)	—	Sensor ground (Throttle position sensor)	—	—	—
37 (W)	112 (B)	Throttle position sensor 1	Input	[Ignition switch: ON] • Engine stopped • Selector lever: D position • Accelerator pedal: Fully released	More than 0.36 V
				[Ignition switch: ON] • Engine stopped • Selector lever: D position • Accelerator pedal: Fully depressed	Less than 4.75 V
38 (R)	112 (B)	Throttle position sensor 2	Input	[Ignition switch: ON] • Engine stopped • Selector lever: D position • Accelerator pedal: Fully released	Less than 4.75 V
				[Ignition switch: ON] • Engine stopped • Selector lever: D position • Accelerator pedal: Fully depressed	More than 0.36 V
39 (R)	40 (G)	Refrigerant pressure sensor	Input	[Engine is running] • Warm-up condition • Both A/C switch and blower fan motor switch: ON (Compressor operates)	1.0 - 4.0 V
40 (G)	—	Sensor ground (Refrigerant pressure sensor)	—	—	—

A  
B  
C  
D  
E  
F  
G  
H  
HAC  
J  
K  
L  
M  
N  
O  
P

# ECM

< ECU DIAGNOSIS INFORMATION >

[WITH 7 INCH DISPLAY]

Terminal No.		Description		Condition	Value (Approx.)
+	—	Signal name	Input/Output		
41 (O/B)	48 (B/P)	Power steering pressure sensor	Output	[Engine is running] • Steering wheel: Being turned	0.5 - 4.5 V
				[Engine is running] • Steering wheel: Not being turned	0.4 - 0.8 V
42 (BR)	44 (G/B)	Battery current sensor	Input	[Engine is running] • Battery: Fully charged*2 • Idle speed	2.6 - 3.5 V
44 (G/B)	—	Sensor ground (Battery current sensor)	—	—	—
45 (P)	49 (L)	A/F sensor 1 (bank 1)	Input	[Ignition switch: ON]	2.2 V
46 (Y)	52 (B/R)	Engine coolant temperature sensor	Input	[Engine is running]	0 - 4.8 V Output voltage varies with engine coolant temperature.
47 (G)	36 (B)	Sensor power supply (Throttle position sensor)	—	[Ignition switch: ON]	5 V
48 (B/P)	—	Sensor ground (Power steering pressure sensor)	—	—	—
49 (L)	112 (B)	A/F sensor 1 (bank 1)	Input	[Engine is running] • Warm-up condition • Engine speed: 2,000 rpm	1.8 V Output voltage varies with air fuel ratio.
50 (L/Y)	56 (G/B)	Intake air temperature sensor	Input	[Engine is running]	0 - 4.8 V Output voltage varies with intake air temperature.
51 (R/Y)	44 (G/B)	Sensor power supply (Battery current sensor)	—	[Ignition switch: ON]	5 V
52 (B/R)	—	Sensor ground (Engine coolant temperature sensor/Engine oil temperature sensor)	—	—	—
53 (V)	57 (LG)	A/F sensor 1 (bank 2)	Input	[Ignition switch: ON]	2.2 V
54 (G)	52 (B/R)	Engine oil temperature sensor	Input	[Engine is running]	0 - 4.8 V Output voltage varies with engine oil temperature.
55 (SB)	48 (Y)	Sensor power supply (Power steering pressure sensor)	—	[Ignition switch: ON]	5 V
56 (G/B)	—	Sensor ground (Mass air flow sensor/Intake air temperature sensor)	—	—	—
57 (LG)	112 (B)	A/F sensor 1 (bank 2)	Input	[Engine is running] • Warm-up condition • Engine speed: 2,000 rpm	1.8 V Output voltage varies with air fuel ratio.
58 (O)	56 (G/B)	Mass air flow sensor	Input	[Engine is running] • Warm-up condition • Idle speed	0.9 - 1.2 V
				[Engine is running] • Warm-up condition • Engine speed: 2,500 rpm	1.6 - 1.9 V



# ECM

< ECU DIAGNOSIS INFORMATION >

[WITH 7 INCH DISPLAY]

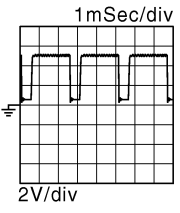
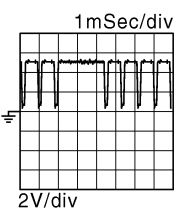
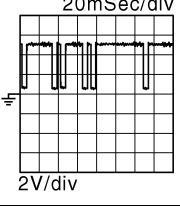
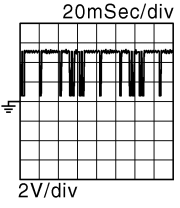
Terminal No.		Description		Condition	Value (Approx.)
+	-	Signal name	Input/Output		
59 (G/W)	64 (B/R)	Sensor power supply [Camshaft position sensor (PHASE) (bank 1)]	—	[Ignition switch: ON]	5 V
60 (Y/B)	—	Sensor ground [Crankshaft position sensor (POS)]	—	—	—
61 (B)	67 (—)	Knock sensor (bank 1)	Input	[Engine is running] • Idle speed	2.5 V*1
62 (W)	67 (—)	Knock sensor (bank 2)	Input	[Engine is running] • Idle speed	2.5 V*1
63 (R/W)	68 (Y/G)	Sensor power supply [Camshaft position sensor (PHASE) (bank 2)]	—	[Ignition switch: ON]	5 V
64 (B/R)	—	Sensor ground [Camshaft position sensor (PHASE) (bank 1)]	—	—	—
65 (W/B)	60 (Y/B)	Crankshaft position sensor (POS)	Input	[Engine is running] • Warm-up condition • Idle speed <b>NOTE:</b> The pulse cycle changes depending on rpm at idle	4.0 - 5.0 V★ 
				[Engine is running] • Engine speed: 2,000 rpm	4.0 - 5.0 V★ 
67 (—)	—	Sensor ground (Knock sensor)	—	—	—
68 (Y/G)	—	Sensor ground [Camshaft position sensor (PHASE) (bank 2)]	—	—	—
69 (BR/W)	68 (Y/G)	Camshaft position sensor (PHASE) (bank 2)	Input	[Engine is running] • Warm-up condition • Idle speed <b>NOTE:</b> The pulse cycle changes depending on rpm at idle	3.0 - 5.0 V★ 
				[Engine is running] • Engine speed is 2,000 rpm	3.0 - 5.0 V★ 

A

B

C

D

E

F

G

H

HAC

J

K

L

M

N

O

P

# ECM

< ECU DIAGNOSIS INFORMATION >

[WITH 7 INCH DISPLAY]

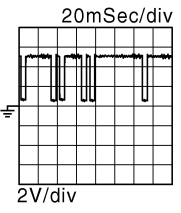
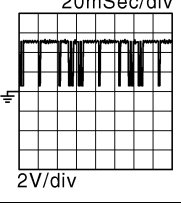
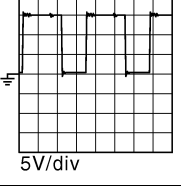
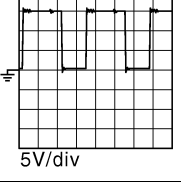
Terminal No.		Description		Condition	Value (Approx.)
+	-	Signal name	Input/Output		
70 (W/R)	64 (B/R)	Camshaft position sensor (PHASE) (bank 1)	Input	[Engine is running] • Warm-up condition • Idle speed <b>NOTE:</b> The pulse cycle changes depending on rpm at idle	3.0 - 5.0 V★ 
				[Engine is running] • Engine speed is 2,000 rpm	3.0 - 5.0 V★ 
72 (BR/W)	40 (G)	Sensor power supply (Refrigerant pressure sensor)	—	[Ignition switch: ON]	5 V
75 (Y)	112 (B)	Intake valve timing control solenoid valve (bank 2)	Output	[Engine is running] • Warm-up condition • Idle speed	BATTERY VOLTAGE (11 - 14 V)
				[Engine is running] • Warm-up condition • Engine speed: 2,000 rpm	7 - 12 V★ 
76 (R/G)	60 (Y/B)	Sensor power supply [Crankshaft position sensor (POS)]	—	[Ignition switch: ON]	5 V
77 (W/L)	112 (B)	Power supply for ECM (Back-up)	Input	[Ignition switch: OFF]	BATTERY VOLTAGE (11 - 14 V)
78 (R/L)	112 (B)	Intake valve timing control solenoid valve (bank 1)	Output	[Engine is running] • Warm-up condition • Idle speed	BATTERY VOLTAGE (11 - 14 V)
				[Engine is running] • Warm-up condition • Engine speed: 2,000 rpm	7 - 12 V★ 
81 (W)	84 (B)	Accelerator pedal position sensor 1	Input	[Ignition switch: ON] • Engine stopped • Accelerator pedal: Fully released	0.5 - 1.0 V
				[Ignition switch: ON] • Engine stopped • Accelerator pedal: Fully depressed	4.2 - 4.8 V

# ECM

< ECU DIAGNOSIS INFORMATION >

[WITH 7 INCH DISPLAY]

Terminal No.		Description		Condition	Value (Approx.)	
+	—	Signal name	Input/Output			
82 (O)	100 (G)	Accelerator pedal position sensor 2	Input	[Ignition switch: ON] • Engine stopped • Accelerator pedal: Fully released	0.25 - 0.50 V	A
				[Ignition switch: ON] • Engine stopped • Accelerator pedal: Fully depressed	2.0 - 2.5 V	B
83 (BR)	84 (B)	Sensor power supply (Accelerator pedal position sensor 1)	—	[Ignition switch: ON]	5 V	C
84 (B)	—	Sensor ground (Accelerator pedal position sensor 1)	—	—	—	D
85 (Y)	92 (BR)	ASCDC steering switch	Input	[Ignition switch: ON] • ASCDC steering switch: OFF	4 V	E
				[Ignition switch: ON] • MAIN switch: Pressed	0 V	F
				[Ignition switch: ON] • CANCEL switch: Pressed	1 V	G
				[Ignition switch: ON] • RESUME/ACCELERATE switch: Pressed	3 V	H
				[Ignition switch: ON] • SET/COAST switch: Pressed	2 V	HAC
86 (SB)	96 (GR)	EVAP control system pressure sensor	Input	[Ignition switch: ON]	1.8 - 4.8 V	I
87 (GR)	100 (G)	Sensor power supply (Accelerator pedal position sensor 2)	—	[Ignition switch: ON]	5 V	J
88 (O)	—	Data link connector	Input/Output	—	—	K
91 (L)	96 (GR)	Sensor power supply (EVAP control system pressure sensor)	—	[Ignition switch: ON]	5 V	L
92 (BR)	—	Sensor ground (ASCDC steering switch)	—	—	—	M
93 (BR)	112 (B)	Ignition switch	Input	[Ignition switch: OFF]	0 V	N
				[Ignition switch: ON]	BATTERY VOLTAGE (11 - 14 V)	O

# ECM

< ECU DIAGNOSIS INFORMATION >

[WITH 7 INCH DISPLAY]

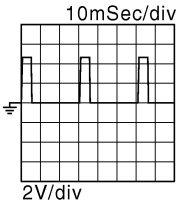
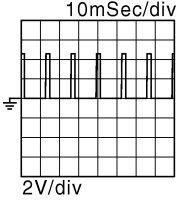
Terminal No.		Description		Condition	Value (Approx.)
+	—	Signal name	Input/Output		
94 (GR)	112 (B)	Engine speed output signal	Output	[Engine is running] • Warm-up condition • Idle speed <b>NOTE:</b> The pulse cycle changes depending on rpm at idle	1 V★ 
				[Engine is running] • Engine speed: 2,000 rpm	1 V★ 
95 (Y)	104 (SB)	Fuel tank temperature sensor	Input	[Engine is running]	0 - 4.8 V Output voltage varies with fuel tank temperature.
96 (GR)	—	Sensor ground (EVAP control system pressure sensor)	—	—	—
97 (P)	—	CAN communication line	Input/Output	—	—
98 (L)	—	CAN communication line	Input/Output	—	—
100 (G)	—	Sensor ground (Accelerator pedal position sensor 2)	—	—	—
102 (R)	112 (B)	PNP signal	Input	[Ignition switch: ON] • Selector lever: P or N position	BATTERY VOLTAGE (11 - 14 V)
				[Ignition switch: ON] • Selector lever: Except above position	0 V
104 (SB)	—	Sensor ground (Fuel tank temperature sensor)	—	—	—
105 (V)	112 (B)	Power supply for ECM	Input	[Ignition switch: ON]	BATTERY VOLTAGE (11 - 14 V)
106 (SB)	112 (B)	Stop lamp switch	Input	[Ignition switch: OFF] • Brake pedal: Fully released	0 V
				[Ignition switch: OFF] • Brake pedal: Slightly depressed	BATTERY VOLTAGE (11 - 14 V)
107 (B) 108 (B)	—	ECM ground	—	—	—
109 (W)	112 (B)	EVAP canister vent control valve	Output	[Ignition switch: ON]	BATTERY VOLTAGE (11 - 14 V)

# ECM

< ECU DIAGNOSIS INFORMATION >

[WITH 7 INCH DISPLAY]

Terminal No.		Description		Condition	Value (Approx.)
+	—	Signal name	Input/Output		
110 (G)	112 (B)	ASCD brake switch	Input	[Ignition switch: ON] • Brake pedal: Slightly depressed	0 V
				[Ignition switch: ON] • Brake pedal: Fully released	BATTERY VOLTAGE (11 - 14 V)
111 (B) 112 (B)	—	ECM ground	—	—	—

★: Average voltage for pulse signal (Actual pulse signal can be confirmed by oscilloscope.)

\*1: This may vary depending on internal resistance of the tester.

\*2: Before measuring the terminal voltage, confirm that the battery is fully charged. Refer to [PG-3, "How to Handle Battery"](#).

A  
B  
C  
D  
E  
F  
G  
H  
J  
K  
L  
M  
N  
O  
P

HAC

# A/C AUTO AMP.

< ECU DIAGNOSIS INFORMATION >

[WITH 7 INCH DISPLAY]

## A/C AUTO AMP.

### Reference Value

INFOID:000000005514748

### VALUES ON THE DIAGNOSIS TOOL

#### CONSULT-III MONITOR ITEM

Monitor item	Condition		Value/Status
COMP REQ SIG	Engine: Run at idle after warming up	A/C switch: ON (Compressor operation status)	On
		A/C switch: OFF	Off
FAN REQ SIG	Engine: Run at idle after warming up	Blower fan: ON	On
		Blower fan: OFF	Off
AMB TEMP SEN	Ignition switch ON	—	22 - 131°F (-30 - 55°C)
IN-VEH TEMP	Ignition switch ON	—	22 - 131°F (-30 - 55°C)
INT TEMP SEN	Ignition switch ON	—	22 - 131°F (-30 - 55°C)
SUNLOAD SEN	Ignition switch ON	—	0 - 1045 w/m <sup>2</sup> (0 - 900 kcal/m <sup>2</sup> ·h)
AMB SEN CAL	Ignition switch ON	—	22 -131°F (-30 - 55°C)
IN-VEH CAL	Ignition switch ON	—	22 -131°F (-30 - 55°C)
INT TEMP CAL	Ignition switch ON	—	22 -131°F (-30 - 55°C)
SUNL SEN CAL	Ignition switch ON	—	0 - 1045 w/m <sup>2</sup> (0 - 900 kcal/m <sup>2</sup> ·h)
FAN DUTY	Engine: Run at idle after warming up	Blower fan: ON	25 - 81
		Blower fan: OFF	0
XM	Ignition switch ON	—	-100 - 155
ENG COOL TEMP	Ignition switch ON	—	Values according to coolant temperature
VEHICLE SPEED	Driving	—	Equivalent to speedometer reading

### TERMINAL LAYOUT

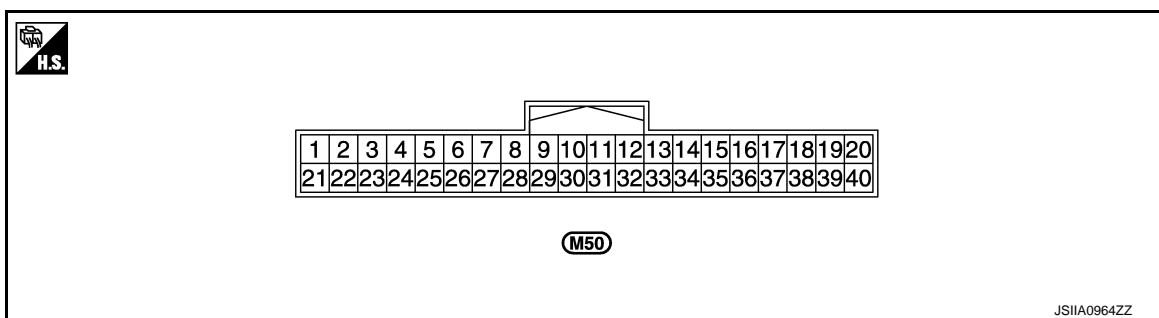

### PHYSICAL VALUES

# A/C AUTO AMP.

< ECU DIAGNOSIS INFORMATION >

[WITH 7 INCH DISPLAY]

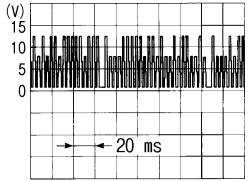
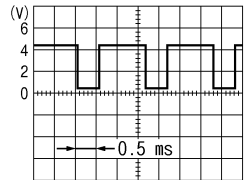
Terminal No. (Wire color)		Description		Condition	Value (Approx.)
+	-	Signal name	Input/ Output		
10 (L)	Ground	LAN signal	Input/ Output	—	 <p style="text-align: right; font-size: small;">SJIA1453J</p>
11 (R)	Ground	Power supply for each door motor	Input	Ignition switch ON	Battery voltage
15 (O)	Ground	Sunload sensor	Input	—	—
16 (G)	Ground	Intake sensor	Input	—	—
17 (R)	Ground	Power supply from ACC	—	Ignition switch ACC	Battery voltage
19 (B)	Ground	Ground	—	Ignition switch ON	0 V
20 (G)	Ground	Power supply from IGN	—	Ignition switch ON	Battery voltage
32 (L)	Ground	Blower motor control signal	Output	<ul style="list-style-type: none"> <li>• Ignition switch ON</li> <li>• Blower speed: 1st speed (manual)</li> </ul>	 <p style="text-align: right; font-size: small;">JSIA0096ZZ</p>
34 (P)	Ground	Power supply for ambient meter	Output	Ignition switch ON	5V
35 (L)	Ground	Ambient sensor	Input	—	—
36 (LG)	Ground	In-vehicle sensor	Input	—	—
37 (Y)	Ground	Sensor ground	—	Ignition switch ON	0 V
39 (B)	Ground	Ground	—	Ignition switch ON	0 V
40 (Y)	Ground	Power supply from BATT	—	Ignition switch OFF	Battery voltage

A  
B  
C  
D  
E  
F  
G  
H  
HAC  
J  
K  
L  
M  
N  
O  
P

# A/C AUTO AMP.

< ECU DIAGNOSIS INFORMATION >

[WITH 7 INCH DISPLAY]

## Wiring Diagram - AIR CONDITIONER CONTROL SYSTEM -

INFOID:000000005713284

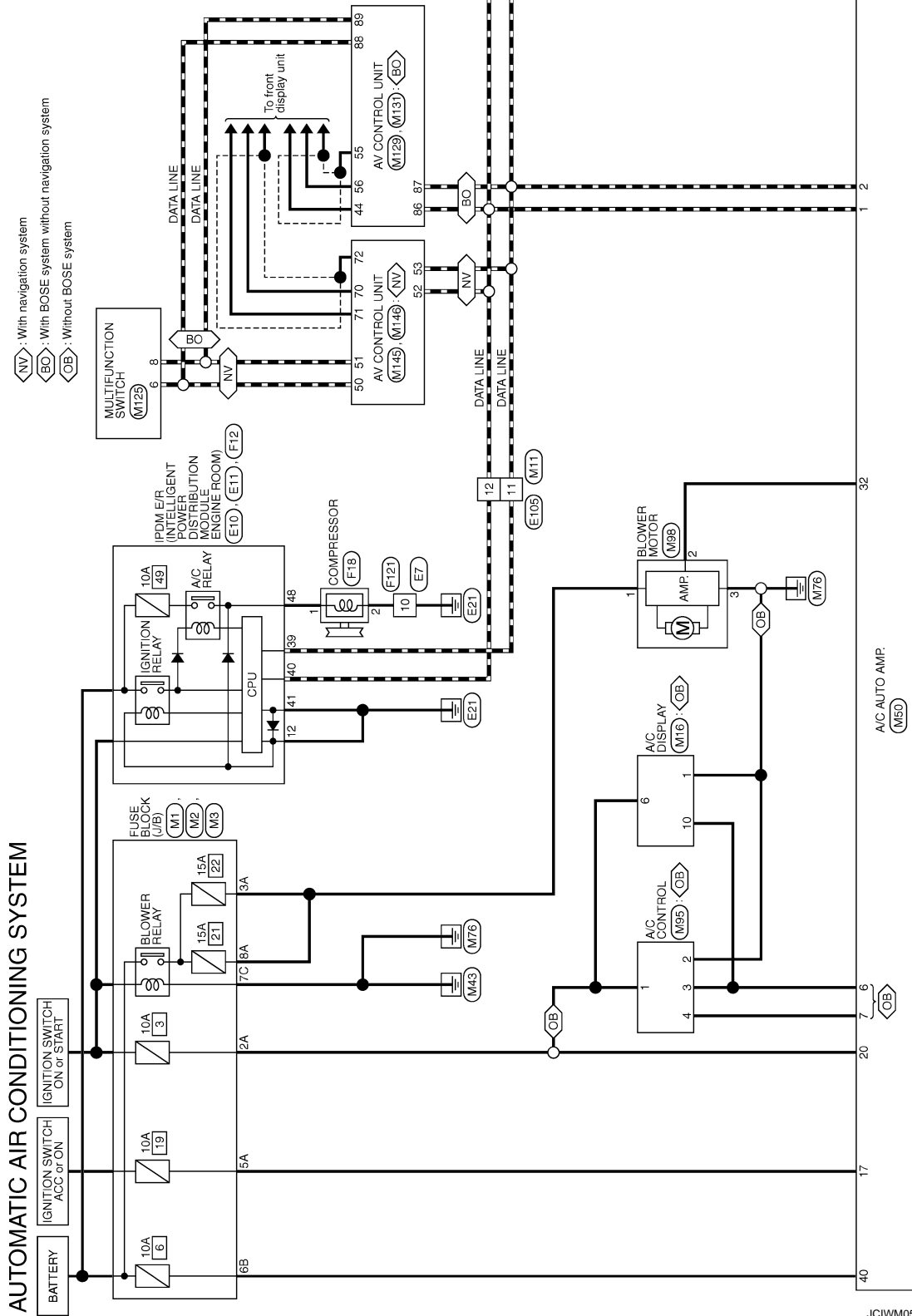



# A/C AUTO AMP.

< ECU DIAGNOSIS INFORMATION >

[WITH 7 INCH DISPLAY]

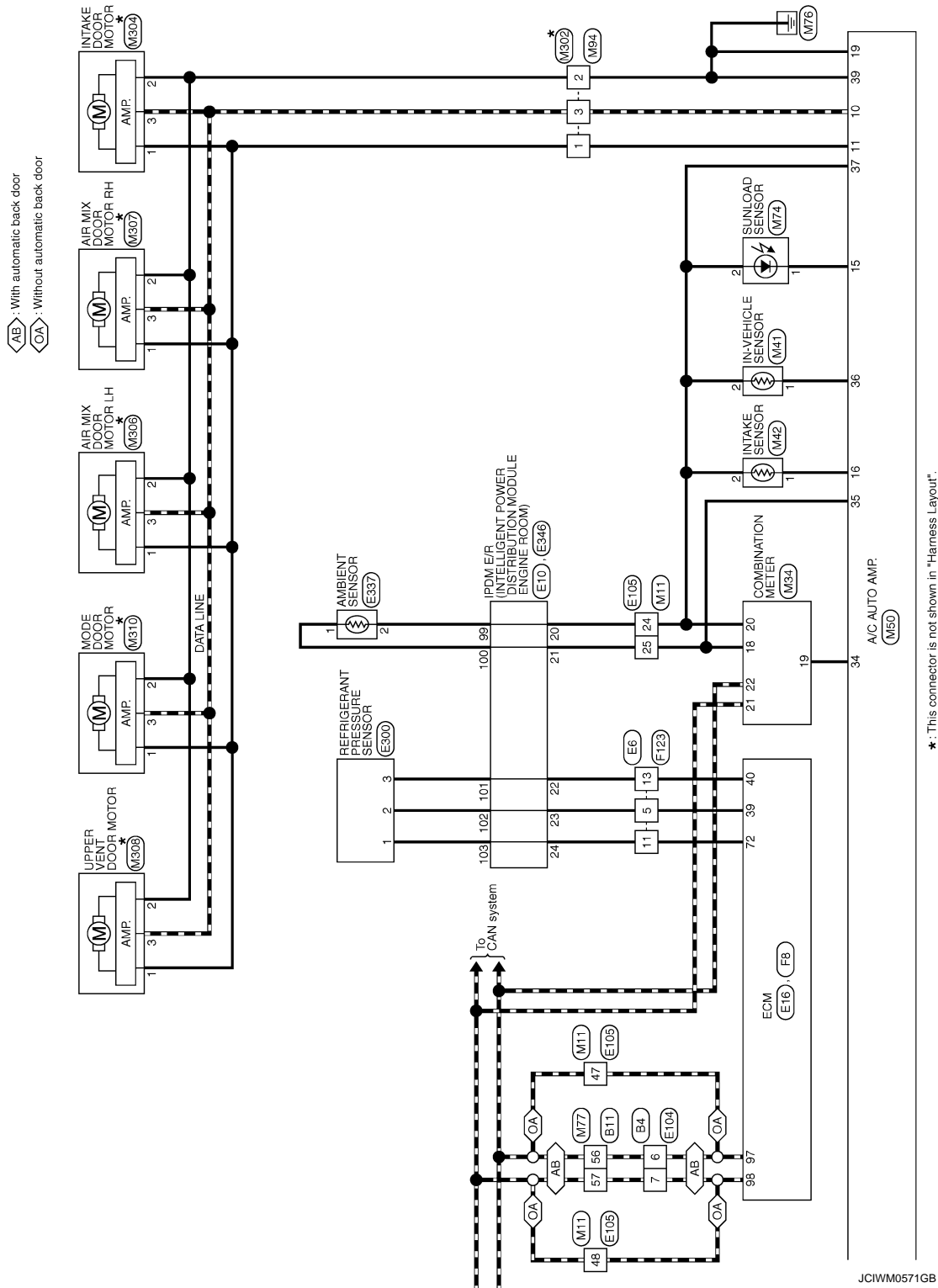

\*: This connector is not shown in "Harness Layout".

JCIWM0571GB

A  
B  
C  
D  
E  
F  
G  
H  
HAC  
J  
K  
L  
M  
N  
O  
P

AUTOMATIC AIR CONDITIONING SYSTEM

Connector No.	B4
Connector Name	WIRE TO WIRE
Connector Type	HS16MW-CS



1	2	3	4	5	6	7		
8	9	10	11	12	13	14	15	16

Terminal No.	Color of Wire	Signal Name [Specification]
1	SB	-
2	W	-
3	W	-
4	R	-
5	O	-
6	P	-
7	L	-
8	B	-
9	LG	-
10	V	-
11	L	-
12	BR	-
13	P	-
14	BR	-
15	O	-
16	G	-

Connector No.	B11
Connector Name	WIRE TO WIRE
Connector Type	HS80MW-CS19



Terminal No.	Color of Wire	Signal Name [Specification]
1	SHIELD	-
2	B	-
3	R/L	-
4	R/W	-
5	SB	-
6	P	-

7	V	-
8	SHIELD	-
9	BP/L	-
10	V/G	-
11	V/L	-
12	W/L	-
13	L	-
14	BR	-
15	SB	-
16	BR	-
17	V	-
18	SB	-
19	R	-
20	P	-
21	LG	-
22	W	-
23	Y	-
24	GR	-
25	Y	-
27	V	-
28	W/L	-
30	P	-
31	O	-
32	BR	-
34	SB	-
35	SHIELD	-
36	L/O	-
37	LG	-
40	Y	-
41	O	-
42	SB	-
43	G	-
44	BR	-
45	L	-
46	GR	-
47	V	-
48	GR	- [With rear view camera and telephone]
48	BR	- [With rear view camera without telephone]
49	Y	-
50	SHIELD	-
51	B	-
52	B	-
53	Y	-
54	LG	-
55	BR	-
56	P	-
57	L	-
58	R	-
59	SHIELD	-
60	B	-
61	R/L	-
62	R/W	-

1	L	-
3	Y	-
4	R	-
5	GR	-
6	V	-
8	P	-
10	W	-
11	G	-
12	BR	-
13	SB	-
14	B	-
15	O	-

Connector No.	E7
Connector Name	WIRE TO WIRE
Connector Type	HS10MW-CS



1	2	3	4		
5	6	7	8	9	10

Terminal No.	Color of Wire	Signal Name [Specification]
1	B	-
2	L	-
5	R	-
6	B	-
7	O	-
10	B	-

Connector No.	E6
Connector Name	WIRE TO WIRE
Connector Type	TK16MGY-IV



1	2	3	4	5	6	7		
8	9	10	11	12	13	14	15	16

Terminal No.	Color of Wire	Signal Name [Specification]
--------------	---------------	-----------------------------

**AUTOMATIC AIR CONDITIONING SYSTEM**

Connector No.	E10
Connector Name	SMALL INTELLIGENT POWER DISTRIBUTION MODULE ENGINE ROOM
Connector Type	TH20PW-CS12-M4-TV



Connector No.	E11
Connector Name	SMALL INTELLIGENT POWER DISTRIBUTION MODULE ENGINE ROOM
Connector Type	TH20PW-MH



97	P	VEHCAN-L
98	L	VEHCAN-H
100	G	GND-A-APSZ
102	R	NEUT-H
104	SB	GND-TF
105	V	VBR
106	SB	BRAKE
107	B	GND
108	B	GND
109	W	ODCV
110	G	BNCSW
111	B	GND
112	B	GND

Connector No.	E104
Connector Name	WIRE TO WIRE
Connector Type	NS16FW-CS

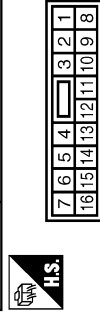

Terminal No.	Color of Wire	Signal Name [Specification]
4	LG	-
5	Y	-
7	GR	-
10	BR	-
11	P	-
12	B	-
13	SB	-
15	W	-
16	L/Y	-
19	Y	-
20	L	-
21	O	-
22	SB	-
23	GR	-
24	G	-
25	GR	-
26	Y	-
27	W	-
28	SB	-
30	BR	-
32	V	-
33	G	-
34	O	-
35	P	-
36	G	-
38	GR	-

Terminal No.	Color of Wire	Signal Name [Specification]
39	P	-
40	L	-
41	B	-
42	SB	-
43	Y	-
44	W	-
45	O	-
46	BR	-

Connector No.	E16
Connector Name	ECM
Connector Type	RH24FE-RZ8-L-LH

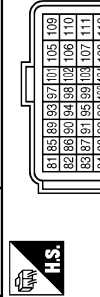

Terminal No.	Color of Wire	Signal Name [Specification]
81	W	APSI
82	O	APSZ
83	BR	AVCOI-APSI
84	B	GND-A-APSI
85	Y	ASCD SW
86	SB	FTPRES
87	GR	AVCCZ-APSZ
88	O	KLINE
91	L	AVCCZ-FTPRES
92	BR	GND-A-ASQDSW
93	BR	IGN SW
94	GR	TACHO(CABIN)
95	Y	TF
96	GR	GND-A-FTPRES

Terminal No.	Color of Wire	Signal Name [Specification]
1	Y	-
2	SB	-
3	L	-
4	R	-
5	L	-
6	P	-
7	L	-
8	B/W	-
9	SB	-
10	GR	-
11	R	-
12	W	-
13	P	-
14	V	-
15	Y	-
16	L	-

A  
B  
C  
D  
E  
F  
G  
H  
HAC  
J  
K  
L  
M  
N  
O  
P

AUTOMATIC AIR CONDITIONING SYSTEM

Connector No.	E105
Connector Name	WIRE TO WIRE
Connector Type	TH70MW-CS10-M3

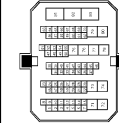

Terminal No.	Color of Wire	Signal Name [Specification]
2	BR	-
3	Y	-
4	W	-
5	LG	-
6	GR	-
8	G	-
11	P	-
12	L	-
13	Y	-
14	O	-
15	BR	-
20	Y	-
21	BR	-
22	P	-
23	P	-
24	L	-
25	O	-
26	G	-
27	V	-
28	SB	-
29	W	-
30	Y	-
43	P	-
46	L	-
49	SB	-
50	GR	-
51	LG	-
52	V	-
53	GR	-
54	BR	-
55	Y	-
56	W/L	-
60	V	-
61	BR	-
62	O	-
63	L/O	-
64	SHIELD	-
66	W	-

67	BR	-
68	Y	-
69	SB	-
70	GR	-
71	SB	-
72	Y	-
73	L	-
74	W	-
75	BR	-
76	GR	-
77	O	-
78	V	-
79	Y	-
80	R	-
81	W	-
82	LG	-
83	O	-

Connector No.	E200
Connector Name	REFRIGERANT PRESSURE SENSOR
Connector Type	RK03FB



Terminal No.	Color of Wire	Signal Name [Specification]
1	P	-
2	B	-
3	L	-

Connector No.	E337
Connector Name	AMBIENT SENSOR
Connector Type	RS02FB



Terminal No.	Color of Wire	Signal Name [Specification]
1	P	-
2	B	-
3	L	-

1	SB	-
2	BR	-

Connector No.	E316
Connector Name	SPRINKLER INTELLIGENT POWER DISTRIBUTION MODULE (SPRINKLER)
Connector Type	TH18FW-NH



Terminal No.	Color of Wire	Signal Name [Specification]
91	R	-
92	LG	-
93	BR	-
100	SB	-
101	L	-
102	B	-
103	P	-

Connector No.	F8
Connector Name	ECM
Connector Type	RH40FBR-R28-L-LH

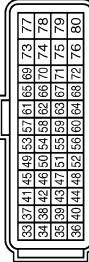

Terminal No.	Color of Wire	Signal Name [Specification]
33	W	OZSR1
34	W/L	OZSR2
35	B	GND-OZSR1,OZSR2
36	B	GND-TPS-BI
37	W	TPS1-BI
38	R	TPS2-BI
39	R	PDPRES
40	G	GND-PDPRES
41	O/B	PSPRES
42	BR	CURSEM
44	G/B	GND-CURSINTP

45	P	AF-1
46	Y	TW
47	G	AVCCI-TPS-BI
48	B/P	GND-PSPRES
49	L	AF-1
50	L/Y	TA1
51	R/Y	AVCCI-CURSINTP
52	B/R	GND-TW101
53	V	AF-2
54	G	TO1
55	SB	AVCCI-PSPRES
56	G/B	GA-GND-TA1
57	LG	AF-2
58	O	OAI+
59	G/W	AVCCI-PHASE1EP1
60	Y/B	GND-POS
61	B	KK1
62	W	KK2
63	R/W	AVCCI-PHASE2EP2
64	B/R	GND-PHASE1EP1
65	W/B	POS
67	SHIELD	GND-KK1,KK2
68	Y/G	GND-PHASE2EP2
69	BR/W	PHASE1
70	W/R	PHASE2
72	BR/W	AVCC2-PDPRES
75	Y	CVTCH2
76	R/G	AVCC2-POS
77	W/L	BAIT
78	R/L	CVTCH1

AUTOMATIC AIR CONDITIONING SYSTEM

Connector No.	F12
Connector Name	SWAYLE INTELLIGENT POWER DISTRIBUTION MODULE FUSE BLOCK
Connector Type	TH20PW-CS12-M4

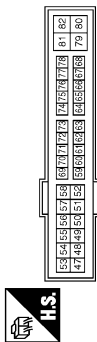

4	3	2	1
10	9	8	7
6	5	4	3
2	1	0	9

Connector No.	F121
Connector Name	WIRE TO WIRE
Connector Type	NS10PFW-CS



4	3	2	1
10	9	8	7
6	5	4	3
2	1	0	9

Terminal No.	Color of Wire	Signal Name [Specification]
48	W	-
49	R/B	-
51	LG	-
52	Y/G	-
53	R/W	-
54	G/W	-
55	W/L	-
56	R/Y	-
57	O	-
58	Y	-
69	W/B	-
70	O	-
72	R/B	-
75	LG	-
76	SB	-
77	GR	-
80	B	-

Connector No.	F18
Connector Name	COMPRESSOR
Connector Type	RH2ZFB

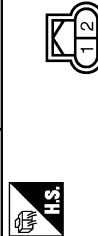

Terminal No.	Color of Wire	Signal Name [Specification]
1	W	-
2	B	-

Connector No.	M1
Connector Name	FUSE BLOCK (J/B)
Connector Type	NS08FW-M2



3	2	1
10	9	8
7	6	5
4	3	2

Terminal No.	Color of Wire	Signal Name [Specification]
1A	Y	-
2A	G	-
3A	Y	-
4A	GR	-
5A	R	-
6A	W	-
7A	LG	-
8A	Y	-

Connector No.	M2
Connector Name	FUSE BLOCK (J/B)
Connector Type	NS10PFW-CS



4	3	2	1
10	9	8	7
6	5	4	3
2	1	0	9

Terminal No.	Color of Wire	Signal Name [Specification]
1B	W	-
2B	L	-
3B	L	-
4B	G	-
5B	L	-
6B	Y	-
7B	R	-
8B	R	-
9B	GR	-

Connector No.	M3
Connector Name	FUSE BLOCK (J/B)
Connector Type	NS12PFW-CS



5	4	3	2	1
10	9	8	7	6
5	4	3	2	1
10	9	8	7	6

Terminal No.	Color of Wire	Signal Name [Specification]
6C	BR	-
7C	B	-
8C	G	-
9C	GR	-
10C	SB	-
11C	R	-
12C	O	-

A  
B  
C  
D  
E  
F  
G  
H  
HAC  
J  
K  
L  
M  
N  
O  
P

AUTOMATIC AIR CONDITIONING SYSTEM

Connector No.	M11
Connector Name	WIRE TO WIRE
Connector Type	TH40PW-CS10-M3

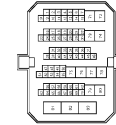

Terminal No.	Color of Wire	Signal Name [Specification]
2	L	-
3	P	-
4	O	-
5	O	-
6	G	-
8	R	-
11	P	-
12	L	-
13	V	-
14	Y	-
15	R	-
20	Y	-
21	BR	-
22	G	-
23	P	-
24	Y	-
25	L	-
26	L	-
27	O	-
28	BR	-
29	L	-
30	R	-
42	P	-
46	L	-
49	W	-
50	GR	-
51	LG	-
52	Y	-
53	V	-
54	SB	-
55	P	-
56	SB	-
60	V	-
61	GR	-
62	O	-
63	V	-
64	SHIELD	-
66	W	-

Connector No.	M16
Connector Name	A/C DISPLAY
Connector Type	TH10PE-NH

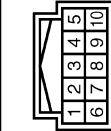

Terminal No.	Color of Wire	Signal Name [Specification]
1	B	GND
6	G	IGN
8	R	ILL+
9	BR	ILL-
10	L	RX(AMP/DISP)

Connector No.	M34
Connector Name	COMBINATION METER
Connector Type	TH40PW-NH



Terminal No.	Color of Wire	Signal Name [Specification]
1	Y	BAT
2	O	IGN
3	B	GROUND
4	B	GROUND
5	SB	ILLUMINATION CONTROL
8	SB	TRIP RESET SWITCH
9	W	SMALL POWER
10	O	METER CONTROL SW GND
11	L	ENTER SWITCH
12	R	SELECT SWITCH
13	V	ILLUMINATION CONTROL SWITCH (SWB automatic drive position)
13	Y	ILLUMINATION CONTROL SWITCH (VW automatic drive position)
14	GR	ILLUMINATION CONTROL SWITCH (-)
15	BR	AIR BAG
18	L	AMBIENT SENSOR
19	P	AMBIENT SENSOR POWER
20	Y	AMBIENT SENSOR GROUND
21	L	CAN-H
22	P	CAN-L
23	B	GROUND
24	W	FUEL LEVEL SENSOR GROUND
25	BR	CHG
26	G	PARKING BRAKE SWITCH
27	V	BRAKE FLUID LEVEL SWITCH
29	R	WASHER LEVEL SWITCH
30	P	VEHICLE SPEED (2-PULSE)
31	V	VEHICLE SPEED (8-PULSE)
32	LG	OD OFF/SPORTS
34	G	FUEL LEVEL SENSOR
35	SB	SEAT BELT BUCKLE SWITCH (DRIVER SIDE)
36	R	SEAT BELT BUCKLE SWITCH (PASSENGER SIDE)

Connector No.	M41
Connector Name	IN-VEHICLE SENSOR
Connector Type	A02FW



Terminal No.	Color of Wire	Signal Name [Specification]
1	LG	-
2	Y	-

Connector No.	M42
Connector Name	INTAKE SENSOR
Connector Type	C02FW



Terminal No.	Color of Wire	Signal Name [Specification]
1	G	-
2	Y	-

Connector No.	M60
Connector Name	A/C AUTO AMP.
Connector Type	ISAB0FW



Terminal No.	Color of Wire	Signal Name [Specification]
1	L	CAN-H
2	P	CAN-L
6	L	TX(AMP/SW&DISP)
7	P	RX(SW&AMP)
10	L	CAN SIG
11	R	VACTR
15	O	SUN SENS
16	G	INTAKE SENS
17	R	ACC
19	B	GND
20	G	IGN
26	GR	RR DEF F/B
27	BR	RR DEF ON
32	L	FAN PWM
34	P	AMB POWER
35	L	AMB SENS
36	LG	INCAR SENS
37	Y	SENS GND
39	B	GND(POWER)
40	Y	BAT

# A/C AUTO AMP.

< ECU DIAGNOSIS INFORMATION >

[WITH 7 INCH DISPLAY]

## AUTOMATIC AIR CONDITIONING SYSTEM

Connector No.	M74
Connector Name	SUNLOAD SENSOR
Connector Type	K02PE



Terminal No.	Color of Wire	Signal Name [Specification]
1	O	-
2	Y	-

Connector No.	M77
Connector Name	WIRE TO WIRE
Connector Type	TH00FW-C319

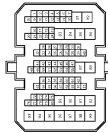

Terminal No.	Color of Wire	Signal Name [Specification]
1	SHIELD	-
2	B	-
3	W	-
4	R	-
5	Y	-
6	W	-
7	G	-
8	SHIELD	-
9	W	-
10	R	-
11	G	-
12	B	-
13	O	-
14	R	-
15	SB	-
16	R	-
17	V	-
18	P	-
19	P	-
20	LG	-

79	B	-
80	W	-
81	LG	-
82	L	-
83	W	- [With automatic drive positioner]
84	GR	- [With driver side power seat]
85	R	-
86	Y	- [With front heated seat and passenger side power seat]
87	GR	- [With front heated seat without passenger side power seat]
88	R	-
89	G	-
90	G	-
91	G	-
92	BR	-
93	P	-
94	V	-
95	O	-
96	SB	-
97	L	-
98	LG	-
99	Y	-

Connector No.	M84
Connector Name	WIRE TO WIRE
Connector Type	A03MW

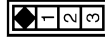

Terminal No.	Color of Wire	Signal Name [Specification]
1	R	-
2	B	-
3	L	-

Connector No.	M85
Connector Name	A/C CONTROL
Connector Type	TH12FW-NH

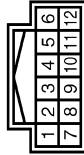

Terminal No.	Color of Wire	Signal Name [Specification]
1	G	IGN
2	B	GND
3	L	RX(AMP-SW)
4	P	TX(SW-AMP)
5	R	ILL*
6	BR	ILL*

Connector No.	M88
Connector Name	BLOWER MOTOR
Connector Type	NS03FW-M3



Terminal No.	Color of Wire	Signal Name [Specification]
1	Y	-
2	L	-
3	B	-

A  
B  
C  
D  
E  
F  
G  
H  
HAC  
J  
K  
L  
M  
N  
O  
P

AUTOMATIC AIR CONDITIONING SYSTEM

Connector No.	M125
Connector Name	MULTIFUNCTION SWITCH
Connector Type	TH16FW-NH

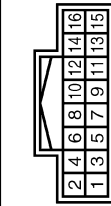

Connector No.	M131
Connector Name	AV CONTROL UNIT WITH BOSE SYSTEM WITHOUT NAVIGATION SYSTEM
Connector Type	TH32FW-NH

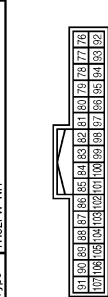

Terminal No.	Color of Wire	Signal Name [Specification]
1	B	GND
3	R	ACC
4	R	ILL
5	SB	ILL CONT
6	R	AV COMM (H)
8	L	AV COMM (L)
9	V	SW GND
14	W	EJECT SIGNAL

Connector No.	M129
Connector Name	AV CONTROL UNIT WITH BOSE SYSTEM WITHOUT NAVIGATION SYSTEM
Connector Type	TH24FW-NH

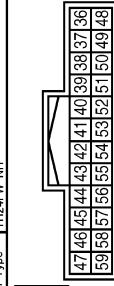

Terminal No.	Color of Wire	Signal Name [Specification]
36	L	COMPOSITE IMAGE SIGNAL
37	P	COMPOSITE IMAGE GND
38	Y	RGB (BLUE) SIGNAL
39	L	RGB (GREEN) SIGNAL
40	G	RGB (RED) SIGNAL
41	B	RGB SYNC
42	SHIELD	SHIELD
43	W	RGB AREA (YS) SIGNAL
44	G	COMM (DISP->CONT)
45	G	HP
46	LG	SIGNAL GND
47	O	SIGNAL V2C
48	SHIELD	SHIELD
50	SHIELD	SHIELD

Connector No.	M145
Connector Name	AV CONTROL UNIT (WITH NAVIGATION SYSTEM)
Connector Type	TH40FW-NH

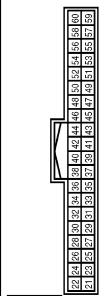

Connector No.	M146
Connector Name	AV CONTROL UNIT (WITH NAVIGATION SYSTEM)
Connector Type	TH12FW-NH

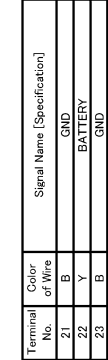

Terminal No.	Color of Wire	Signal Name [Specification]
55	SHIELD	SHIELD
56	R	COMM (CONT->DISP)
57	R	VP
58	BR	INVERTER GND
59	Y	INVERTER VCC
61	SHIELD	SHIELD
62	Y	BATTERY
63	B	BATTERY
64	Y	BATTERY
65	R	ACC
66	B	MICROPHONE VCC
67	SHIELD	MICROPHONE GND
68	W	MICROPHONE SIGNAL
69	G	IGNITION
70	G	PARKING BRAKE
71	SB	REVERSE
72	V	VEHICLE SPEED (8-PULSE)
73	P	CONNECTION RECOGNITION
74	P	CONTROL SIGNAL
75	B	CONTROL SIGNAL
76	G	AV COMM (H)
77	L	AV COMM (L)
78	L	AV COMM (H)
79	L	AV COMM (L)
80	L	CAN-H
81	P	CAN-L
82	W	SOUND SIGNAL RH (-) [With DVD Player]
83	R	IPed SOUND SIGNAL RH (-) [Without DVD Player]
84	R	SOUND SIGNAL RH (+) [With DVD Player]
85	R	IPed SOUND SIGNAL RH (+) [Without DVD Player]
86	L	GND
87	P	CAN-H
88	R	AV COMM (H)
89	L	AV COMM (L)
90	G	AV COMM (H)
91	L	AV COMM (L)
92	R	AUX SOUND SIGNAL RH (+)
93	R	AUX SOUND SIGNAL LH (+)
94	W	AUX SOUND SIGNAL GND
95	G	SOUND SIGNAL LH (-) [With DVD Player]
96	L	IPed SOUND SIGNAL LH (-) [Without DVD Player]
97	B	SOUND SIGNAL LH (+) [With DVD Player]
98	B	IPed SOUND SIGNAL LH (+) [Without DVD Player]
99	BR	SOUND SIGNAL LH (+) [With DVD Player]
100	SHIELD	SHIELD [With DVD player]
101	SHIELD	SHIELD [Without DVD player]
102	V	SW GND
103	W	EJECT SIGNAL
104	G	IGNITION
105	SB	REVERSE
106	G	PARKING BRAKE
107	V	VEHICLE SPEED (8-PULSE)

Terminal No.	Color of Wire	Signal Name [Specification]
62	R	RGB (GREEN) SIGNAL
63	W	RGB (BLUE) SIGNAL
64	SHIELD	SHIELD
65	B	RGB SYNC
66	SHIELD	SHIELD
67	W	RGB AREA (YS) SIGNAL
68	B	HP
69	R	VP
70	R	COMM (CONT->DISP)
71	G	COMM (DISP->CONT)
72	SHIELD	SHIELD

Connector No.	M302
Connector Name	WIRE TO WIRE
Connector Type	AQ3FW



Terminal No.	Color of Wire	Signal Name [Specification]
1	-	-
2	-	-
3	-	-

Connector No.	M304
Connector Name	INTAKE DOOR MOTOR
Connector Type	AQ3FW



Terminal No.	Color of Wire	Signal Name [Specification]
1	-	-
2	-	-
3	-	-



A  
B  
C  
D  
E  
F  
G  
H  
HAC  
J  
K  
L  
M  
N  
O  
P

**AUTOMATIC AIR CONDITIONING SYSTEM**

Connector No.	M306
Connector Name	AIR MIX DOOR MOTOR LH
Connector Type	A03FW

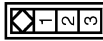

Terminal No.	Color of Wire	Signal Name [Specification]
1	-	-
2	-	-
3	-	-

Connector No.	M307
Connector Name	AIR MIX DOOR MOTOR RH
Connector Type	A03FW

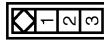

Terminal No.	Color of Wire	Signal Name [Specification]
1	-	-
2	-	-
3	-	-

Connector No.	M308
Connector Name	UPPER VENT DOOR MOTOR
Connector Type	A03FW

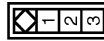

Terminal No.	Color of Wire	Signal Name [Specification]
1	-	-
2	-	-
3	-	-

1	-
2	-
3	-



Connector No.	M310
Connector Name	MODE DOOR MOTOR
Connector Type	A03FW

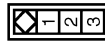

Terminal No.	Color of Wire	Signal Name [Specification]
1	-	-
2	-	-
3	-	-

JCIWM0579GB

INFOID:000000005514750

**Fail-Safe**

**FAIL-SAFE FUNCTION**

- If a communication error exists between the A/C auto amp., and the AV control unit and preset switch for 30 seconds or longer, air conditioner is controlled under the following conditions:

# A/C AUTO AMP.

< ECU DIAGNOSIS INFORMATION >

[WITH 7 INCH DISPLAY]

**Compressor** : ON  
**Air outlet** : AUTO  
**Air inlet** : FRE (Fresh)  
**Blower fan speed** : AUTO  
**Set temperature** : Setting before communication error occurs

## DTC Inspection Priority Chart

INFOID:000000005514751

If some DTCs are displayed at the same time, perform inspections one by one based on the following priority chart.

Priority	Detected items (DTC)
1	<ul style="list-style-type: none"> <li>U1000: CAN COMM CIRCUIT</li> <li>U1010: CONTROL UNIT (CAN)</li> </ul>
2	<ul style="list-style-type: none"> <li>B257B: AMB TEMP SEN SHORT</li> <li>B257C: AMB TEMP SEN OPEN</li> <li>B2578: IN CAR SEN SHORT</li> <li>B2579: IN CAR SEN OPEN</li> <li>B2581: EVAP TEMP SEN SHORT</li> <li>B2582: EVAP TEMP SEN OPEN</li> <li>B2630: SUNLOAD SEN SHORT</li> <li>B2631: SUNLOAD SEN OPEN</li> <li>B2632: DR AIRMIX ACTR SHORT</li> <li>B2633: DR AIRMIX ACTR OPEN</li> <li>B2634: PASS AIRMIX ACTR SHORT</li> <li>B2635: PASS AIRMIX ACTR OPEN</li> <li>B2636: DR VENT DOOR FAIL</li> <li>B2637: DR B/L DOOR FAIL</li> <li>B2638: DR D/F1 DOOR FAIL</li> <li>B2639: DR DEF DOOR FAIL</li> <li>B263D: FRE DOOR FAIL</li> <li>B263E: 20P FRE DOOR FAIL</li> <li>B263F: REC DOOR FAIL</li> <li>B2654: D/F2 DOOR FAIL</li> <li>B2655: B/L2 DOOR FAIL</li> <li>B2661: UPPER VENT DOOR OPEN POSI FAIL</li> <li>B2662: UPPER VENT DOOR MID POSI FAIL</li> <li>B2663: UPPER VENT DOOR SHUT POSI FAIL</li> </ul>

## DTC Index

INFOID:000000005514752

DTC	Items (CONSULT-III screen terms)	Reference
U1000	CAN COMM CIRCUIT	<a href="#">HAC-165, "DTC Logic"</a>
U1010	CONTROL UNIT (CAN)	<a href="#">HAC-166, "DTC Logic"</a>
B257B	AMB TEMP SEN SHORT	<a href="#">HAC-167, "DTC Logic"</a>
B257C	AMB TEMP SEN OPEN	<a href="#">HAC-167, "DTC Logic"</a>
B2578	IN CAR SEN SHORT	<a href="#">HAC-170, "DTC Logic"</a>
B2579	IN CAR SEN OPEN	<a href="#">HAC-170, "DTC Logic"</a>
B2581	EVAP TEMP SEN SHORT	<a href="#">HAC-173, "DTC Logic"</a>
B2582	EVAP TEMP SEN OPEN	<a href="#">HAC-173, "DTC Logic"</a>
B2630*	SUNLOAD SEN SHORT	<a href="#">HAC-176, "DTC Logic"</a>
B2631*	SUNLOAD SEN OPEN	<a href="#">HAC-176, "DTC Logic"</a>
B2632	DR AIRMIX ACTR SHORT	<a href="#">HAC-179, "DTC Logic"</a>
B2633	DR AIRMIX ACTR OPEN	<a href="#">HAC-179, "DTC Logic"</a>

# A/C AUTO AMP.

< ECU DIAGNOSIS INFORMATION >

[WITH 7 INCH DISPLAY]

DTC	Items (CONSULT-III screen terms)	Reference
B2634	PASS AIRMIX ACTR SHORT	<a href="#">HAC-181, "DTC Logic"</a>
B2635	PASS AIRMIX ACTR OPEN	<a href="#">HAC-181, "DTC Logic"</a>
B2636	DR VENT DOOR FAIL	<a href="#">HAC-183, "DTC Logic"</a>
B2637	DR B/L DOOR FAIL	<a href="#">HAC-183, "DTC Logic"</a>
B2638	DR D/F1 DOOR FAIL	<a href="#">HAC-183, "DTC Logic"</a>
B2639	DR DEF DOOR FAIL	<a href="#">HAC-183, "DTC Logic"</a>
B263D	FRE DOOR FAIL	<a href="#">HAC-186, "DTC Logic"</a>
B263E	20P FRE DOOR FAIL	<a href="#">HAC-186, "DTC Logic"</a>
B263F	REC DOOR FAIL	<a href="#">HAC-186, "DTC Logic"</a>
B2654	D/F2 DOOR FAIL	<a href="#">HAC-183, "DTC Logic"</a>
B2655	B/L2 DOOR FAIL	<a href="#">HAC-183, "DTC Logic"</a>
B2661	UPPER VENT DOOR OPEN POSI FAIL	<a href="#">HAC-188, "DTC Logic"</a>
B2662	UPPER VENT DOOR MID POSI FAIL	<a href="#">HAC-188, "DTC Logic"</a>
B2663	UPPER VENT DOOR SHUT POSI FAIL	<a href="#">HAC-188, "DTC Logic"</a>

\*: Perform self-diagnosis under sunshine. When performing indoors, aim a light (more than 60 W) at sunload sensor, otherwise self-diagnosis indicates even though the sunload sensor is functioning normally.

A  
B  
C  
D  
E  
F  
G  
H  
J  
K  
L  
M  
N  
O  
P

HAC

# AIR CONDITIONER CONTROL

< SYMPTOM DIAGNOSIS >

[WITH 7 INCH DISPLAY]

## SYMPTOM DIAGNOSIS

### AIR CONDITIONER CONTROL

#### Diagnosis Chart By Symptom

INFOID:000000005514753

Symptom	Reference	
A/C system does not activate.	Go to Trouble Diagnosis Procedure for A/C System.	<a href="#">HAC-197, "A/C AUTO AMP. : Diagnosis Procedure"</a>
A/C system cannot be controlled.	Go to Trouble Diagnosis Procedure for Preset Switch System.	<a href="#">AV-520, "Symptom Table"</a> (bose audio without navigation) or <a href="#">AV-773, "Symptom Table"</a> (bose audio with navigation)
Air outlet does not change.	Go to Trouble Diagnosis Procedure for Mode Door Motor. (LAN)	<a href="#">HAC-184, "Diagnosis Procedure"</a>
Mode door motor does not operate normally.		
Discharge air temperature does not change.	Go to Trouble Diagnosis Procedure for Air Mix Door Motor. (LAN)	<a href="#">HAC-180, "Diagnosis Procedure"</a> (driver side) or <a href="#">HAC-182, "Diagnosis Procedure"</a> (passenger side)
Air mix door motor does not operate normally.		
Intake door does not change.	Go to Trouble Diagnosis Procedure for Intake Door Motor. (LAN)	<a href="#">HAC-187, "Diagnosis Procedure"</a>
Intake door motor does not operate normally.		
Blower motor operation is malfunctioning.	Go to Trouble Diagnosis Procedure for Blower Motor.	<a href="#">HAC-191, "Diagnosis Procedure"</a>
Magnet clutch does not engage.	Go to Trouble Diagnosis Procedure for Magnet Clutch.	<a href="#">HAC-195, "Diagnosis Procedure"</a>
Insufficient cooling	Go to Trouble Diagnosis Procedure for Insufficient Cooling.	<a href="#">HAC-229, "Inspection procedure"</a>
No cool air comes out. (Air flow volume is normal.)		
Insufficient heating	Go to Trouble Diagnosis Procedure for Insufficient Heating.	<a href="#">HAC-232, "Inspection procedure"</a>
No warm air comes out. (Air flow volume is normal.)		
Noise	Go to Trouble Diagnosis Procedure for Noise.	<a href="#">HAC-235, "Inspection procedure"</a>
Memory function does not operate.	Go to Trouble Diagnosis Procedure for Memory Function.	<a href="#">HAC-237, "Inspection procedure"</a>

## INSUFFICIENT COOLING

## Description

INFOID:000000005514754

## Symptom

- Insufficient cooling
- No cool air comes out. (Air flow volume is normal.)

## Inspection procedure

INFOID:000000005514755

**1. CHECK WITH A GAUGE OF RECOVERY/RECYCLING RECHARGING EQUIPMENT**

Connect the recovery/recycling recharging equipment to the vehicle and perform the pressure inspection with the gauge.

Is there refrigerant?

- YES >> GO TO 2.  
 NO-1 >> Check for refrigerant leakages with the refrigerant leakage detecting fluorescent leak detector. Refer to [HA-30, "Inspection"](#).  
 NO-2 >> GO TO 2 after repairing or replacing the parts according to the inspection results.

**2. CHECK CHARGED REFRIGERANT AMOUNT**

1. Connect recovery/recycling recharging equipment to the vehicle and discharge the refrigerant.
2. Recharge with the proper amount of refrigerant and perform the inspection with the refrigerant leakage detecting fluorescent leak detector. Refer to [HA-30, "Inspection"](#).

Is the inspection result normal?

- YES >> GO TO 3.  
 NO >> Refill the refrigerant and repair or replace the parts according to the inspection results.

**3. CHECK REFRIGERANT CYCLE PRESSURE**

Connect recovery/recycling recharging equipment to the vehicle and perform the performance test. Refer to [HA-28, "Performance Chart"](#).

Is the inspection result normal?

- YES >> GO TO 4.  
 NO >> Perform the diagnosis with the gauge pressure. Refer to [HA-8, "Trouble Diagnosis For Unusual Pressure"](#).

**4. CHECK SETTING OF TEMPERATURE SETTING TRIMMER**

Using CONSULT-III, check the setting of "TEMP SET CORRECT" on "WORK SUPPORT" of HVAC. Refer to [HAC-131, "Temperature Setting Trimmer"](#).

1. Check that the temperature setting trimmer is set to "+ direction".

**NOTE:**

The control temperature can be set with the setting of the temperature setting trimmer.

2. Set temperature control dial to "0".

Are the malfunction solved?

- YES >> Perform the setting separately if necessary. END.  
 NO >> GO TO 5.

**5. CHECK WITH SELF-DIAGNOSIS FUNCTION OF CONSULT-III**

1. Using CONSULT-III, perform "SELF-DIAGNOSIS RESULTS" of HVAC.
2. Check if any DTC No. is displayed in the trouble diagnosis results.

**NOTE:**

If DTC is displayed along with DTC U1000 or U1010, first diagnose the DTC U1000 or U1010. Refer to [HAC-165, "DTC Logic"](#) or [HAC-166, "DTC Logic"](#).

Is any DTC No. displayed?

- YES >> Perform the diagnosis that is applicable to the sensor and the door motor. Refer to [HAC-226, "DTC Index"](#).  
 NO >> GO TO 6.

**6. CHECK WITH ACTIVE TEST OF CONSULT-III**

# INSUFFICIENT COOLING

< SYMPTOM DIAGNOSIS >

[WITH 7 INCH DISPLAY]

- Using CONSULT-III, perform "HVAC TEST" "ACTIVE TEST" of HVAC to check each output device. Refer to [HAC-161, "CONSULT-III Function"](#).  
**NOTE:**  
Perform the ACTIVE TEST after starting the engine because the compressor is operated.
- Refer to the table and check the outlet, inlet, air flow temperature, blower motor control signal, magnet clutch operation, and air mix ratio. Visually check each operating condition, by listening for noise, touching air outlets with a hand, etc.

	Test item						
	MODE 1	MODE 2	MODE 3	MODE 4	MODE 5	MODE 6	MODE 7
Mode door position	VENT1	VENT2	B/L1	B/L2	FOOT	D/F	DEF
Intake door position	REC	REC	20%FRE	20%FRE	FRE	FRE	FRE
Air mix door position (driver & passenger side)	FULL COLD	FULL HOT	FULL COLD	FULL HOT	FULL HOT	FULL HOT	FULL HOT
Blower motor duty ratio	35%	35%	61%	61%	81%	81%	35%
Compressor (Magnet clutch)	ON	ON	ON	ON	OFF	OFF	ON
Upper ventilator door	OPEN	SHUT	OPEN	SHUT	SHUT	SHUT	SHUT

**NOTE:**

Perform the inspection of each output device after starting the engine because the compressor is operated.

Discharge air flow							
Mode position indication	Condition	Air outlet/distribution					
		VENT			FOOT		DEF
		Front	Upper	Rear	Front	Rear	
	DUAL switch: OFF UPPER VENT switch : ON	81%	8%	11%	—	—	—
		41%	10%	17%	24%	8%	—
		12%	12%	16%	27%	10%	23%
		11%	11%	14%	25%	10%	29%
		11%	11%	12%	—	—	66%

JPIIA0509GB

Discharge air flow							
Mode position indication	Condition	Air outlet/distribution					
		VENT			FOOT		DEF
		Front	Upper	Rear	Front	Rear	
	DUAL switch: OFF UPPER VENT switch : OFF	88%	—	12%	—	—	—
		47%	—	18%	26%	9%	—
		13%	—	17%	33%	12%	25%
		12%	—	16%	28%	12%	32%
		11%	—	15%	—	—	74%

JPIIA0510GB

Does it operate normally?

YES >> GO TO 7.

# INSUFFICIENT COOLING

< SYMPTOM DIAGNOSIS >

[WITH 7 INCH DISPLAY]

- NO-1 >> Air outlet does not change. Refer to [HAC-184, "Diagnosis Procedure"](#).
- NO-2 >> Air inlet does not change. Refer to [HAC-187, "Diagnosis Procedure"](#).
- NO-3 >> Discharge air temperature does not change. Refer to [HAC-180, "Diagnosis Procedure"](#) and [HAC-182, "Diagnosis Procedure"](#).
- NO-4 >> Blower motor does not operate normally. Refer to [HAC-191, "Diagnosis Procedure"](#).
- NO-5 >> Magnet clutch does not operate. Refer to [HAC-195, "Diagnosis Procedure"](#).

A  
B

## 7. CHECK AMBIENT TEMPERATURE DISPLAY

Check that there is not much difference between actual ambient temperature and indicated temperature on information display in combination meter.

Is the inspection result normal?

- YES >> GO TO 8.
- NO >> Perform the diagnosis for the A/C auto amp. connection recognition signal. Refer to [MWI-55, "Diagnosis Procedure"](#).

C  
D

## 8. CHECK DRIVE BELT

Check tension of the drive belt. Refer to [EM-17, "Checking"](#).

Is the inspection result normal?

- YES >> GO TO 9.
- NO >> Adjust or replace drive belt.

E  
F

## 9. CHECK AIR LEAKAGE FROM DUCT

Check duct and nozzle, etc, of the A/C system for air leakage.

Is the inspection result normal?

- YES >> INSPECTION END
- NO >> Repair or replace parts according to the inspection results.

G  
H

HAC

J  
K  
L  
M  
N  
O  
P

## INSUFFICIENT HEATING

## Description

INFOID:000000005514756

## Symptom

- Insufficient heating
- No warm air comes out. (Air flow volume is normal.)

## Inspection procedure

INFOID:000000005514757

**1. CHECK COOLING SYSTEM**

1. Check engine coolant level and check for leakage. Refer to [CO-11, "Inspection"](#).
2. Check radiator cap. Refer to [CO-15, "RADIATOR CAP : Inspection"](#).
3. Check water flow sounds of engine coolant. Refer to [CO-12, "Refilling"](#).

Is the inspection result normal?

- YES >> GO TO 2.  
NO >> Refill the engine coolant and repair or replace the parts according to the inspection results.

**2. CHECK OPERATION**

1. Press temperature dial (driver side) and raise temperature setting to 32°C (90°F) after warming up the engine.
2. Check that warm air blows from the outlets.

Is the inspection result normal?

- YES >> INSPECTION END  
NO >> GO TO 3.

**3. CHECK SETTING OF TEMPERATURE SETTING TRIMMER**

Using CONSULT-III, check the setting of "TEMP SET CORRECT" on "WORK SUPPORT" of HVAC. Refer to [HAC-131, "Temperature Setting Trimmer"](#).

1. Check that the temperature setting trimmer is set to "– direction".

**NOTE:**

The control temperature can be set by the temperature setting trimmer.

2. Set temperature control dial to "0".

Are the malfunction solved?

- YES >> Perform the setting separately if necessary. END.  
NO >> GO TO 4.

**4. CHECK WITH SELF-DIAGNOSIS FUNCTION OF CONSULT-III**

1. Using CONSULT-III, perform "SELF-DIAGNOSIS RESULTS" of HVAC.
2. Check if any DTC No. is displayed in the trouble diagnosis results.

**NOTE:**

If DTC is displayed along with DTC U1000 or U1010, first diagnose the DTC U1000 or U1010. Refer to [HAC-165, "DTC Logic"](#) or [HAC-166, "DTC Logic"](#).

Is any DTC No. displayed?

- YES >> Perform the diagnosis that is applicable to the sensor and the door motor. Refer to [HAC-226, "DTC Index"](#).  
NO >> GO TO 5.

**5. CHECK WITH ACTIVE TEST OF CONSULT-III**

1. Using CONSULT-III, perform "HVAC TEST" in "ACTIVE TEST" of HVAC to check each output device. Refer to [HAC-161, "CONSULT-III Function"](#).

**NOTE:**

Perform the ACTIVE TEST after starting the engine because the compressor is operated.

2. Refer to the table and check the outlet, inlet, air flow temperature, blower motor control signal, magnet clutch operation, and air mix ratio. Visually check each operating condition, by listening for noise, touching air outlets with a hand, etc.



# INSUFFICIENT HEATING

< SYMPTOM DIAGNOSIS >

[WITH 7 INCH DISPLAY]

	Test item						
	MODE 1	MODE 2	MODE 3	MODE 4	MODE 5	MODE 6	MODE 7
Mode door position	VENT1	VENT2	B/L1	B/L2	FOOT	D/F	DEF
Intake door position	REC	REC	20%FRE	20%FRE	FRE	FRE	FRE
Air mix door position (driver & passenger side)	FULL COLD	FULL HOT	FULL COLD	FULL HOT	FULL HOT	FULL HOT	FULL HOT
Blower motor duty ratio	35%	35%	61%	61%	81%	81%	35%
Compressor (Magnet clutch)	ON	ON	ON	ON	OFF	OFF	ON
Upper ventilator door	OPEN	SHUT	OPEN	SHUT	SHUT	SHUT	SHUT

**NOTE:**

Perform the inspection of each output device after starting the engine because the compressor is operated.

Discharge air flow							
Mode position indication	Condition	Air outlet/distribution					
		VENT			FOOT		DEF
		Front	Upper	Rear	Front	Rear	
	DUAL switch: OFF UPPER VENT switch : ON	81%	8%	11%	—	—	—
		41%	10%	17%	24%	8%	—
		12%	12%	16%	27%	10%	23%
		11%	11%	14%	25%	10%	29%
		11%	11%	12%	—	—	66%

JPIIA0509GB

Discharge air flow							
Mode position indication	Condition	Air outlet/distribution					
		VENT			FOOT		DEF
		Front	Upper	Rear	Front	Rear	
	DUAL switch: OFF UPPER VENT switch : OFF	88%	—	12%	—	—	—
		47%	—	18%	26%	9%	—
		13%	—	17%	33%	12%	25%
		12%	—	16%	28%	12%	32%
		11%	—	15%	—	—	74%

JPIIA0510GB

Does it operate normally?

YES >> GO TO 6.

NO-1 >> Air outlet does not change. Refer to [HAC-184, "Diagnosis Procedure"](#).

NO-2 >> Air inlet does not change. Refer to [HAC-187, "Diagnosis Procedure"](#).

NO-3 >> Discharge air temperature does not change. Refer to [HAC-180, "Diagnosis Procedure"](#) and [HAC-182, "Diagnosis Procedure"](#).

NO-4 >> Blower motor does not operate normally. Refer to [HAC-191, "Diagnosis Procedure"](#).

NO-5 >> Magnet clutch does not operate. Refer to [HAC-195, "Diagnosis Procedure"](#).

# INSUFFICIENT HEATING

< SYMPTOM DIAGNOSIS >

[WITH 7 INCH DISPLAY]

---

## 6.CHECK AIR LEAKAGE FROM DUCT

---

Check duct and nozzle, etc, of the A/C system for air leakage.

Is the inspection result normal?

YES >> GO TO 7.

NO >> Repair or replace parts according to the inspection results.

---

## 7.CHECK HEATER HOSE INSTALLATION CONDITION

---

Check the heater hose installation condition visually (for twists, crushes, etc.).

Is the inspection result normal?

YES >> GO TO 8.

NO >> Repair or replace parts according to the inspection results.

---

## 8.CHECK TEMPERATURE OF HEATER HOSE

---

1. Check the temperature of inlet hose and outlet hose of heater core.
2. Check that the inlet side of heater core is hot and the outlet side is slightly lower than/almost equal to the inlet side.

**CAUTION:**

**Always perform the temperature inspection in a short period of time because the engine coolant temperature is very hot.**

Is the inspection result normal?

YES >> GO TO 9.

NO >> Replace the heater core after performing the procedures after the cooling system inspection. GO TO 1.

---

## 9.REPLACE HEATER CORE

---

Replace the heater core. Refer to heater core. Refer to [VTL-107, "Exploded View"](#).

Are the malfunction solved?

YES >> INSPECTION END

NO >> Perform the procedures again after the cooling system inspection. GO TO 1.

## NOISE

### Description

INFOID:000000005514758

#### Symptom

- Noise
- Noise is heard when the A/C system operates.

### Inspection procedure

INFOID:000000005514759

#### 1.CHECK OPERATION

1. Operate the A/C system and check the operation. Refer to [HAC-129. "Description & Inspection"](#).
2. Check the parts where noise is occurring.

##### Can the parts where noise is occurring be checked?

- YES-1 >> Noise from blower motor: GO TO 2.
- YES-2 >> Noise from compressor: GO TO 3.
- YES-3 >> Noise from expansion valve: GO TO 4.
- YES-4 >> Noise from A/C piping (pipe, flexible hose): GO TO 6.
- YES-5 >> Noise from drive belt: GO TO 7.
- NO >> INSPECTION END

#### 2.CHECK BLOWER MOTOR

1. Remove blower motor.
2. Remove foreign materials that are in the blower unit.
3. Check the noise from blower motor again.

##### Is the inspection result normal?

- YES >> INSPECTION END
- NO >> Replace blower motor.

#### 3.CHECK COMPRESSOR

Perform trouble diagnosis for the compressor and check the compressor. Refer to [HA-11. "Symptom Table"](#).

##### Is the inspection result normal?

- YES >> INSPECTION END
- NO >> Refill the refrigerant or replace the compressor according to the inspection results.

#### 4.CHECK WITH GAUGE PRESSURE

Perform the diagnosis with the gauge pressure. Refer to [HA-8. "Trouble Diagnosis For Unusual Pressure"](#).

##### Is the inspection result normal?

- YES >> GO TO 5.
- NO >> Repair or replace parts according to the inspection results.

#### 5.CHECK EXPANSION VALVE

1. Correct the refrigerant with recovery/recycling recharging equipment.
2. Recharge with the proper amount of the collected refrigerant after recycling or new refrigerant.
3. Check for the noise from expansion valve again.

##### Are the malfunction solved?

- YES >> INSPECTION END
- NO >> Replace expansion valve.

#### 6.CHECK A/C PIPING (PIPE, FLEXIBLE HOSE)

1. Check the A/C piping (pipes, flexible hoses) (for deformation and damage, etc.).
2. Check the installation condition of clips and brackets, etc, of the A/C piping (pipes, flexible hoses).

##### Is the inspection result normal?

- YES >> Fix the line with rubber or come vibration absorbing material.
- NO >> Repair or replace parts according to the inspection results.

#### 7.CHECK DRIVE BELT

A  
B  
C  
D  
E  
F  
G  
H  
J  
K  
L  
M  
N  
O  
P

HAC

## NOISE

< SYMPTOM DIAGNOSIS >

[WITH 7 INCH DISPLAY]

---

Check tension of the drive belt. Refer to [EM-17. "Checking"](#).

Is the inspection result normal?

YES >> Check the noise from compressor: GO TO 3.

NO >> Adjust or replace drive belt according to the inspection results.

# MEMORY FUNCTION DOES NOT OPERATE

< SYMPTOM DIAGNOSIS >

[WITH 7 INCH DISPLAY]

## MEMORY FUNCTION DOES NOT OPERATE

### Description

INFOID:000000005514760

#### Symptom

- Memory function does not operate normally.
- The setting is not maintained. (It returns to the initial condition.)

### Inspection procedure

INFOID:000000005514761

#### 1.CHECK OPERATION

1. Set temperature control dial to 32°C (90°F).
2. Press the ON/OFF switch.
3. Turn the ignition switch OFF.
4. Turn the ignition switch ON.
5. Press the AUTO switch.
6. Check that the set temperature is maintained.

#### Is the inspection result normal?

- YES >> INSPECTION END  
NO >> GO TO 2.

#### 2.CHECK POWER SUPPLY AND GROUND CIRCUIT OF A/C AUTO AMP.

Check power supply and ground circuit of the A/C auto amp. Refer to [HAC-197. "A/C AUTO AMP. : Diagnosis Procedure"](#).

#### Is the inspection result normal?

- YES >> Replace the A/C auto amp.  
NO >> Repair or replace malfunctioning parts.

A  
B  
C  
D  
E  
F  
G  
H  
J  
K  
L  
M  
N  
O  
P

HAC

**PRECAUTION****PRECAUTIONS****FOR USA AND CANADA****FOR USA AND CANADA : Precaution for Supplemental Restraint System (SRS) "AIR BAG" and "SEAT BELT PRE-TENSIONER"**

INFOID:000000005514762

The Supplemental Restraint System such as "AIR BAG" and "SEAT BELT PRE-TENSIONER", used along with a front seat belt, helps to reduce the risk or severity of injury to the driver and front passenger for certain types of collision. This system includes seat belt switch inputs and dual stage front air bag modules. The SRS system uses the seat belt switches to determine the front air bag deployment, and may only deploy one front air bag, depending on the severity of a collision and whether the front occupants are belted or unbelted.

Information necessary to service the system safely is included in the "SRS AIR BAG" and "SEAT BELT" of this Service Manual.

**WARNING:**

- To avoid rendering the SRS inoperative, which could increase the risk of personal injury or death in the event of a collision which would result in air bag inflation, all maintenance must be performed by an authorized NISSAN/INFINITI dealer.
- Improper maintenance, including incorrect removal and installation of the SRS, can lead to personal injury caused by unintentional activation of the system. For removal of Spiral Cable and Air Bag Module, see the "SRS AIR BAG".
- Do not use electrical test equipment on any circuit related to the SRS unless instructed to in this Service Manual. SRS wiring harnesses can be identified by yellow and/or orange harnesses or harness connectors.

**PRECAUTIONS WHEN USING POWER TOOLS (AIR OR ELECTRIC) AND HAMMERS****WARNING:**

- When working near the Air Bag Diagnosis Sensor Unit or other Air Bag System sensors with the ignition ON or engine running, DO NOT use air or electric power tools or strike near the sensor(s) with a hammer. Heavy vibration could activate the sensor(s) and deploy the air bag(s), possibly causing serious injury.
- When using air or electric power tools or hammers, always switch the ignition OFF, disconnect the battery, and wait at least 3 minutes before performing any service.

**FOR MEXICO****FOR MEXICO : Precaution for Supplemental Restraint System (SRS) "AIR BAG" and "SEAT BELT PRE-TENSIONER"**

INFOID:000000005716647

The Supplemental Restraint System such as "AIR BAG" and "SEAT BELT PRE-TENSIONER", used along with a front seat belt, helps to reduce the risk or severity of injury to the driver and front passenger for certain types of collision. Information necessary to service the system safely is included in the "SRS AIR BAG" and "SEAT BELT" of this Service Manual.

**WARNING:**

- To avoid rendering the SRS inoperative, which could increase the risk of personal injury or death in the event of a collision which would result in air bag inflation, all maintenance must be performed by an authorized NISSAN/INFINITI dealer.
- Improper maintenance, including incorrect removal and installation of the SRS, can lead to personal injury caused by unintentional activation of the system. For removal of Spiral Cable and Air Bag Module, see the "SRS AIR BAG".
- Do not use electrical test equipment on any circuit related to the SRS unless instructed to in this Service Manual. SRS wiring harnesses can be identified by yellow and/or orange harnesses or harness connectors.

**PRECAUTIONS WHEN USING POWER TOOLS (AIR OR ELECTRIC) AND HAMMERS****WARNING:**

- When working near the Air Bag Diagnosis Sensor Unit or other Air Bag System sensors with the ignition ON or engine running, DO NOT use air or electric power tools or strike near the sensor(s)

# PRECAUTIONS

< PRECAUTION >

[WITH 7 INCH DISPLAY]

with a hammer. Heavy vibration could activate the sensor(s) and deploy the air bag(s), possibly causing serious injury.

- When using air or electric power tools or hammers, always switch the ignition OFF, disconnect the battery, and wait at least 3 minutes before performing any service.

## Precaution Necessary for Steering Wheel Rotation after Battery Disconnect

INFOID:000000005514764

### NOTE:

- Before removing and installing any control units, first turn the push-button ignition switch to the LOCK position, then disconnect both battery cables.
- After finishing work, confirm that all control unit connectors are connected properly, then re-connect both battery cables.
- Always use CONSULT-III to perform self-diagnosis as a part of each function inspection after finishing work. If a DTC is detected, perform trouble diagnosis according to self-diagnosis results.

For vehicle with steering lock unit, if the battery is disconnected or discharged, the steering wheel will lock and cannot be turned.

If turning the steering wheel is required with the battery disconnected or discharged, follow the operation procedure below before starting the repair operation.

### OPERATION PROCEDURE

1. Connect both battery cables.

#### NOTE:

Supply power using jumper cables if battery is discharged.

2. Turn the push-button ignition switch to ACC position. (At this time, the steering lock will be released.)
3. Disconnect both battery cables. The steering lock will remain released with both battery cables disconnected and the steering wheel can be turned.
4. Perform the necessary repair operation.
5. When the repair work is completed, re-connect both battery cables. With the brake pedal released, turn the push-button ignition switch from ACC position to ON position, then to LOCK position. (The steering wheel will lock when the push-button ignition switch is turned to LOCK position.)
6. Perform self-diagnosis check of all control units using CONSULT-III.

## Precaution for Procedure without Cowl Top Cover

INFOID:000000005514765

When performing the procedure after removing cowl top cover, cover the lower end of windshield with urethane, etc.

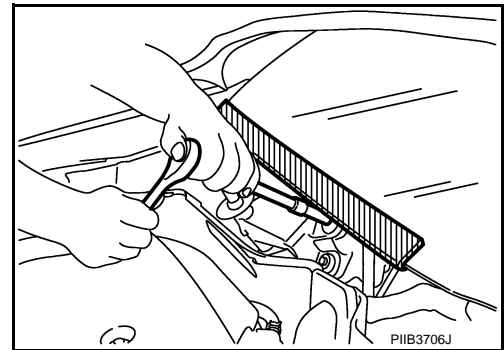

## Precautions For Xenon Headlamp Service

INFOID:000000005514766

### WARNING:

Comply with the following warnings to prevent any serious accident.

- Disconnect the battery cable (negative terminal) or the power supply fuse before installing, removing, or touching the xenon headlamp (bulb included). The xenon headlamp contains high-voltage generated parts.
- Never work with wet hands.
- Check the xenon headlamp ON-OFF status after assembling it to the vehicle. Never turn the xenon headlamp ON in other conditions. Connect the power supply to the vehicle-side connector. (Turning it ON outside the lamp case may cause fire or visual impairments.)
- Never touch the bulb glass immediately after turning it OFF. It is extremely hot.

### CAUTION:

A

B

C

D

E

F

G

H

HAC

J

K

L

M

N

O

P

# PRECAUTIONS

< PRECAUTION >

[WITH 7 INCH DISPLAY]

Comply with the following cautions to prevent any error and malfunction.

- Install the xenon bulb securely. (Insufficient bulb socket installation may melt the bulb, the connector, the housing, etc. by high-voltage leakage or corona discharge.)
- Never perform HID circuit inspection with a tester.
- Never touch the xenon bulb glass with hands. Never put oil and grease on it.
- Dispose of the used xenon bulb after packing it in thick vinyl without breaking it.
- Never wipe out dirt and contamination with organic solvent (thinner, gasoline, etc.).

Working with HFC-134a (R-134a)

INFOID:000000005514767

## CAUTION:

- CFC-12 (R-12) refrigerant and HFC-134a (R-134a) refrigerant are not compatible. Compressor malfunction is likely to occur if the refrigerants are mixed, refer to “CONTAMINATED REFRIGERANT” below. To determine the purity of HFC-134a (R-134a) in the vehicle and recovery tank, use Refrigerant Recovery/Recycling Recharging equipment and Refrigerant Identifier.
- Use only specified lubricant for the HFC-134a (R-134a) A/C system and HFC-134a (R-134a) components. Compressor malfunction is likely to occur if lubricant other than that specified is used.
- The specified HFC-134a (R-134a) lubricant rapidly absorbs moisture from the atmosphere. The following handling precautions must be observed:
  - Immediately cap (seal) the component to minimize the entry of moisture from the atmosphere when removing refrigerant components from a vehicle.
  - Never remove the caps (unseal) until just before connecting the components when installing refrigerant components to a vehicle. Connect all refrigerant loop components as quickly as possible to minimize the entry of moisture into system.
  - Use only the specified lubricant from a sealed container. Immediately reseal containers of lubricant. Lubricant becomes moisture saturated and should not be used without proper sealing.
  - Never allow lubricant (NISSAN A/C System Oil Type S) to come in to contact with styrene foam parts. Damage may result.

## CONTAMINATED REFRIGERANT

Take the appropriate steps shown below if a refrigerant other than pure HFC-134a (R-134a) is identified in a vehicle:

- Explain to the customer that environmental regulations prohibit the release of contaminated refrigerant into the atmosphere.
- Explain that recovery of the contaminated refrigerant could damage service equipment and refrigerant supply.
- Suggest the customer return the vehicle to the location of previous service where the contamination may have occurred.
- If repairing, recover the refrigerant using only **dedicated equipment and containers. Never reintroduce contaminated refrigerant into the existing service equipment.** Contact a local refrigerant product retailer for available service if the facility does not have dedicated recovery equipment. This refrigerant must be disposed of in accordance with all federal and local regulations. In addition, replacement of all refrigerant system components on the vehicle is recommended.
- The air conditioner warranty is void if the vehicle is within the warranty period. Please contact Nissan Customer Affairs for further assistance.

## General Refrigerant Precaution

INFOID:000000005514768

## WARNING:

- Never breath A/C refrigerant, lubricant vapor or mist. Exposure may irritate eyes, nose and throat. Remove HFC-134a (R-134a) from the A/C system, using certified service equipment meeting requirements of SAE J-2210 [HFC-134a (R-134a) recycling equipment], or J-2209 [HFC-134a (R-134a) recovery equipment]. Ventilate work area before resuming service if accidental system discharge occurs. Additional health and safety information may be obtained from refrigerant and lubricant manufacturers.
- Never release refrigerant into the air. Use approved recovery/recycling equipment to capture the refrigerant each time an air conditioning system is discharged.
- Always wear eye and hand protection (goggles and gloves) when working with any refrigerant or air conditioning system.
- Never store or heat refrigerant containers above 52°C (126°F).
- Never heat a refrigerant container with an open flame. Place the bottom of the container in a warm pail of water if container warming is required.



# PRECAUTIONS

[WITH 7 INCH DISPLAY]

## < PRECAUTION >

- Never intentionally drop, puncture, or incinerate refrigerant containers.
- Keep refrigerant away from open flames. Poisonous gas is produced if refrigerant burns.
- Refrigerant displaces oxygen, therefore be certain to work in well ventilated areas to prevent suffocation.
- Never pressure test or leakage test HFC-134a (R-134a) service equipment and/or vehicle air conditioning systems with compressed air during repair. Some mixtures of air and HFC-134a (R-134a) have been shown to be combustible at elevated pressures. These mixtures, if ignited, may cause injury or property damage. Additional health and safety information may be obtained from refrigerant manufacturers.

## Refrigerant Connection

INFOID:000000005514769

A new type refrigerant connection has been introduced to all refrigerant lines except the following location.

- Expansion valve to evaporator
- Refrigerant pressure sensor to liquid tank

## O-RING AND REFRIGERANT CONNECTION

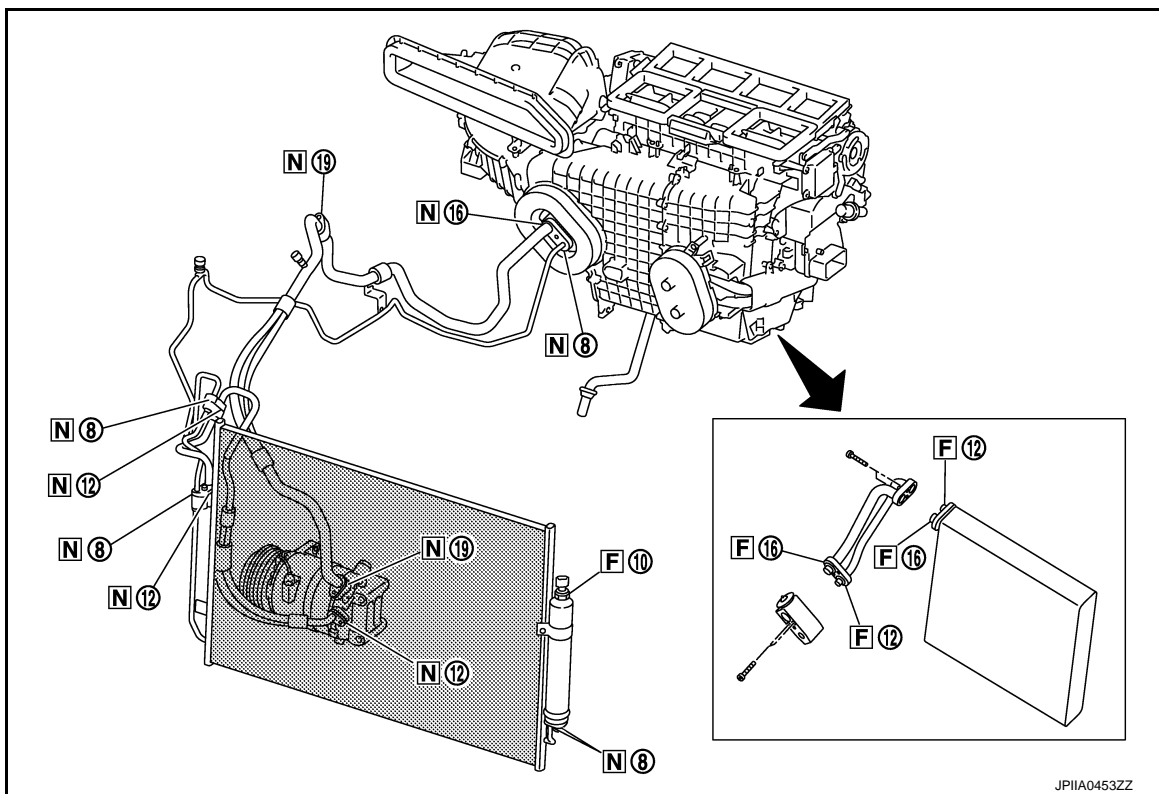

F. Former type refrigerant connection    N. New type refrigerant connection

O: O-ring size

### CAUTION:

The new and former refrigerant connections use different O-ring configurations. Never confuse O-rings since they are not interchangeable. Refrigerant may leak at the connection if a wrong O-ring is installed.

O-Ring Part Numbers and Specifications

# PRECAUTIONS

< PRECAUTION >

[WITH 7 INCH DISPLAY]

Connection type	Piping connection point		Part number	QTY	O-ring size
New	Low-pressure flexible hose to low-pressure pipe		92474 N8210	1	φ19
	High-pressure pipe to condenser pipe assembly (Outlet)		92471 N8210	1	φ8
	Condenser pipe assembly (Inlet) to high-pressure flexible hose (One-touch joint)		92472 N8210	1	φ12
	Condenser assembly to condenser pipe assembly	Inlet	92472 N8210	1	φ12
		Outlet	92471 N8210	1	φ8
	Low-pressure pipe to expansion valve		92473 N8210	1	φ16
	High-pressure pipe to expansion valve		92471 N8210	1	φ8
	Compressor to low-pressure flexible hose		92474 N8210	1	φ19
	Compressor to high-pressure flexible hose		92472 N8210	1	φ12
	Liquid tank to condenser assembly	Inlet	92471 N8210	1	φ8
Outlet		1			
Former	Refrigerant pressure sensor to liquid tank		J2476 89956	1	φ10
	Expansion valve to evaporator pipe assembly	Inlet	92475 71L00	1	φ12
		Outlet	92475 72L00	1	φ16
	Evaporator to evaporator pipe assembly	Inlet	92475 71L00	1	φ12
		Outlet	92475 72L00	1	φ16

**WARNING:**

Check that all refrigerant is discharged into the recycling equipment and the pressure in the system is less than atmospheric pressure. Then gradually loosen the discharge side hose fitting and remove it.

**CAUTION:**

Observe the following when replacing or cleaning refrigerant cycle components.

- Store it in the same way as it is when mounted on the car when the compressor is removed. Failure to do so will cause lubricant to enter the low-pressure chamber.
- Always use a torque wrench and a back-up wrench when connecting tubes.
- Immediately plug all openings to prevent entry of dust and moisture after disconnecting tubes.
- Connect the pipes at the final stage of the operation when installing an air conditioner in the vehicle. Never remove the seal caps of pipes and other components until just before required for connection.
- Allow components stored in cool areas to warm to working area temperature before removing seal caps. This prevents condensation from forming inside A/C components.
- Thoroughly remove moisture from the refrigeration system before charging the refrigerant.
- Replace always used O-rings.
- Apply lubricant to circle of the O-rings shown in illustration when connecting tube. Be careful not to apply lubricant to threaded portion.

**Name** : NISSAN A/C System Oil Type S

- O-ring must be closely attached to the groove portion of tube.
- Be careful not to damage O-ring and tube when replacing the O-ring.
- Connect tube until a click can be heard. Then tighten the nut or bolt by hand. Check that the O-ring is installed to tube correctly.

# PRECAUTIONS

[WITH 7 INCH DISPLAY]

## < PRECAUTION >

- Perform leakage test and make sure that there is no leakage from connections after connecting line. Disconnect the line and replace the O-ring when the refrigerant leaking point is found. Then tighten the connections of seal seat to the specified torque.

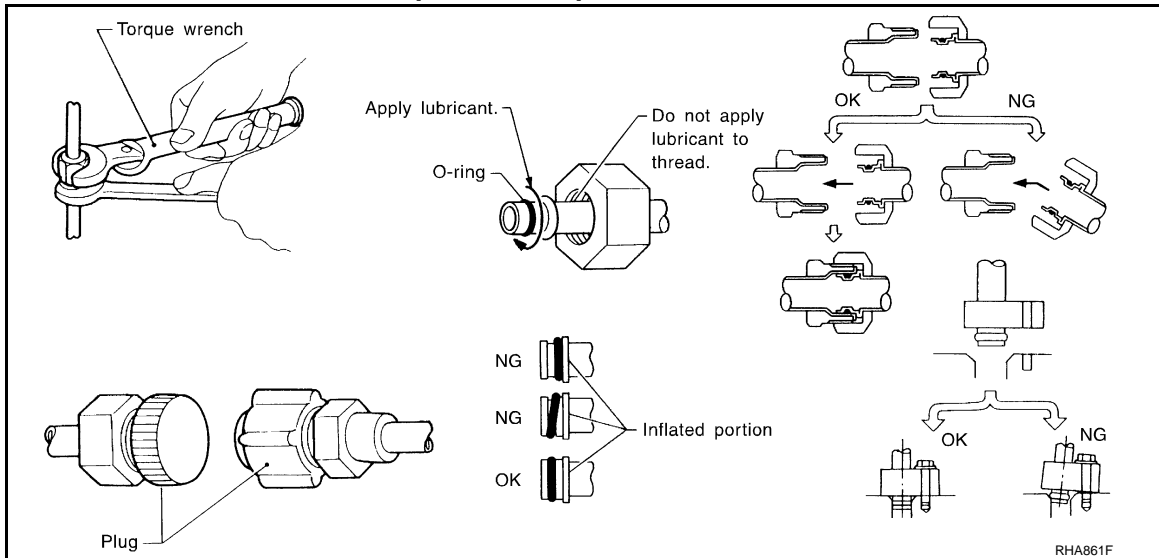

## Service Equipment

INFOID:00000000514770

## RECOVERY/RECYCLING EQUIPMENT

Be certain to follow the manufacturer instructions for machine operation and machine maintenance. Never introduce any refrigerant other than that specified into the machine.

## ELECTRICAL LEAK DETECTOR

Be certain to follow the manufacturer instructions for tester operation and tester maintenance.

## VACUUM PUMP

The lubricant contained inside the vacuum pump is not compatible with the specified lubricant for HFC-134a (R-134a) A/C systems. The vent side of the vacuum pump is exposed to atmospheric pressure. So the vacuum pump lubricant may migrate out of the pump into the service hose. This is possible when the pump is switched OFF after evacuation (vacuuming) and hose is connected to it. To prevent this migration, use a manual valve placed near the hose-to-pump connection, as per the following.

- Vacuum pumps usually have a manual isolator valve as part of the pump. Close this valve to isolate the service hose from the pump.
- Use a hose equipped with a manual shut-off valve near the pump end for pumps without an isolator. Close the valve to isolate the hose from the pump.
- Disconnect the hose from the pump if the hose has an automatic shut-off valve. As long as the hose is connected, the valve is open and lubricating oil may migrate.

Some one-way valves open when vacuum is applied and close under no vacuum condition. Such valves may restrict the ability of the pump to create a deep vacuum and are not recommended.

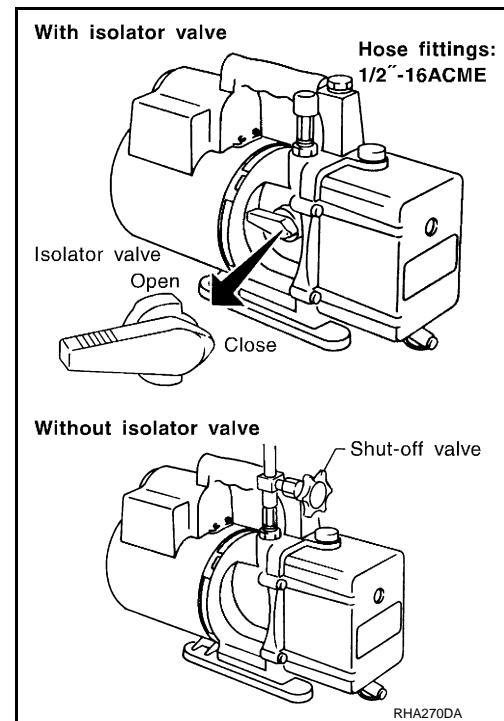

## MANIFOLD GAUGE SET

# PRECAUTIONS

## < PRECAUTION >

Be certain that the gauge face indicates HFC-134a or R-134a. Be sure the gauge set has 1/2"-16 ACME threaded connections for service hoses. Confirm the set has been used only with refrigerant HFC-134a (R-134a) and specified lubricants.

[WITH 7 INCH DISPLAY]

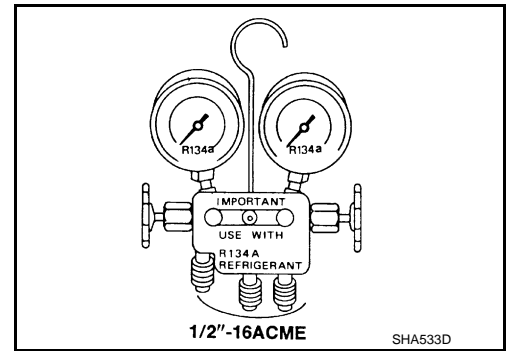

## SERVICE HOSES

Be certain that the service hoses display the markings described (colored hose with a black stripe). All hoses must equip positive shut-off devices (either manual or automatic) near the end of the hoses opposite to the manifold gauge.

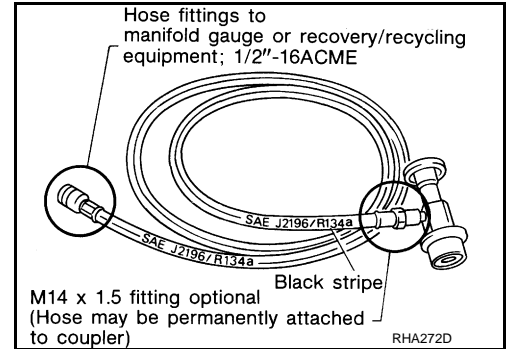

## SERVICE COUPLERS

Never attempt to connect HFC-134a (R-134a) service couplers to a CFC-12 (R-12) A/C system. The HFC-134a (R-134a) couplers do not properly connect to the CFC-12 (R-12) system. However, if an improper connection is attempted, discharge and contamination may occur.

Shut-off valve rotation	A/C service valve
Clockwise	Open
Counterclockwise	Close

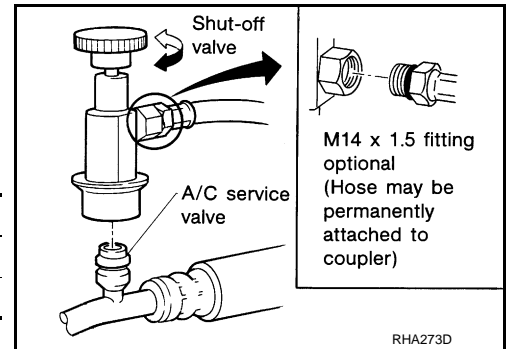

## REFRIGERANT WEIGHT SCALE

Verify that no refrigerant other than HFC-134a (R-134a) and specified lubricants have been used with the scale. The hose fitting must be 1/2"-16 ACME if the scale controls refrigerant flow electronically.

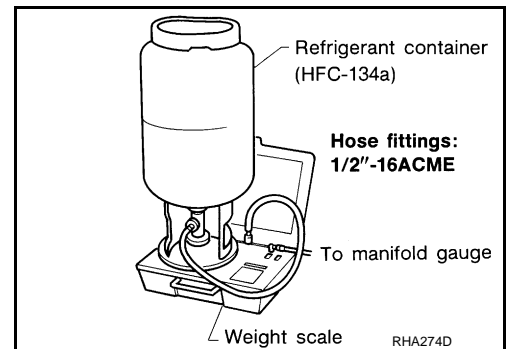

## CHARGING CYLINDER

Use of a charging cylinder is not recommended. Refrigerant may be vented into the air from the top valve of the cylinder when filling the cylinder with refrigerant. Also, the accuracy of the cylinder is generally less than that of an electronic scale or of quality recycle/recharge equipment.

## COMPRESSOR

### General Precautions

INFOID:000000005514771

**CAUTION:**

- Plug all openings to prevent moisture and foreign matter from entering.
- Store it in the same way as it is when mounted on the car when the compressor is removed.
- Follow “Maintenance of Lubricant Quantity in Compressor” exactly when replacing or repairing the compressor. Refer to [HA-25, "Maintenance of Lubricant Quantity"](#).
- Keep friction surfaces between clutch and pulley clean. Wipe it off by using a clean waste cloth moistened with thinner if the surface is contaminated with lubricant.
- Turn the compressor shaft by hand more than five turns in both directions after compressor service operation. This equally distributes lubricant inside the compressor. Let the engine idle and operate the compressor for one hour after the compressor is installed.
- Apply voltage to the new compressor and check for normal operation after replacing the compressor magnet clutch.

A  
B  
C  
D  
E  
F  
G  
H  
J  
K  
L  
M  
N  
O  
P

HAC

# FLUORESCENT LEAK DETECTOR

< PRECAUTION >

[WITH 7 INCH DISPLAY]

## FLUORESCENT LEAK DETECTOR

### General Precautions

INFOID:000000005514772

#### CAUTION:

- The A/C system contains a fluorescent leak detection dye used for locating refrigerant leakages. An ultraviolet (UV) lamp is required to illuminate the dye when inspecting for leakages.
- Always wear fluorescence enhancing UV safety goggles to protect eyes and enhance the visibility of the fluorescent dye.
- The fluorescent dye leak detector is not a replacement for an electrical leak detector (SST: J-41995). The fluorescent dye leak detector should be used in conjunction with an electrical leak detector (SST: J-41995) to pin-point refrigerant leakages.
- Read and follow all manufacture operating instructions and precautions prior to performing the work for the purpose of safety and customer satisfaction.
- A compressor shaft seal should not necessarily be repaired because of dye seepage. The compressor shaft seal should only be repaired after confirming the leakage with an electrical leak detector (SST: J-41995).
- Always remove any remaining dye from the leakage area after repairs are completed to avoid a misdiagnosis during future service.
- Never allow dye to come into contact with painted body panels or interior components. Clean immediately with the approved dye cleaner if dye is spilled. Fluorescent dye left on a surface for an extended period of time cannot be removed.
- Never spray the fluorescent dye cleaning agent on hot surfaces (engine exhaust manifold, etc.).
- Never use more than one refrigerant dye bottle (1/4 ounce /7.4 cc) per A/C system.
- Leak detection dyes for HFC-134a (R-134a) and CFC-12 (R-12) A/C systems are different. Never use HFC-134a (R-134a) leak detection dye in CFC-12 (R-12) A/C system, or CFC-12 (R-12) leak detection dye in HFC-134a (R-134a) A/C system, or A/C system damage may result.
- The fluorescent properties of the dye remains for three or more years unless a compressor malfunction occurs.

### IDENTIFICATION

#### NOTE:

Vehicles with factory installed fluorescent dye have a green label.

Vehicles without factory installed fluorescent dye have a blue label.

### IDENTIFICATION LABEL FOR VEHICLE

Vehicles with factory installed fluorescent dye have an identification label on the front side of hood.