

SECTION **DLN**
DRIVELINE

A
B
C

DLN

CONTENTS

E

TRANSFER: TY20A

BASIC INSPECTION	4	C1210 ECM	18
DIAGNOSIS AND REPAIR WORK FLOW	4	Description	18
Work Flow	4	DTC Logic	18
SYSTEM DESCRIPTION	5	Diagnosis Procedure	18
AWD SYSTEM	5	U1000 CAN COMM CIRCUIT	19
System Diagram	5	Description	19
System Description	6	DTC Logic	19
Component Parts Location	8	Diagnosis Procedure	19
Component Description	9	U1010 CONTROL UNIT (CAN)	20
DIAGNOSIS SYSTEM (AWD CONTROL UNIT)	10	Description	20
CONSULT-III Function	10	DTC Logic	20
DTC/CIRCUIT DIAGNOSIS	12	Diagnosis Procedure	20
C1201 AWD CONTROL UNIT	12	POWER SUPPLY AND GROUND CIRCUIT	21
Description	12	Description	21
DTC Logic	12	Diagnosis Procedure	21
Diagnosis Procedure	12	AWD LOCK SWITCH	23
C1203 ABS ACTUATOR AND ELECTRIC UNIT (CONTROL UNIT)	13	Description	23
Description	13	Component Function Check	23
DTC Logic	13	Diagnosis Procedure	23
Diagnosis Procedure	13	Component Inspection	24
C1204 AWD SOLENOID	14	AWD WARNING LAMP	25
Description	14	Description	25
DTC Logic	14	Component Function Check	25
Diagnosis Procedure	14	Diagnosis Procedure	25
Component Inspection	15	AWD LOCK INDICATOR LAMP	27
C1205 AWD ACTUATOR RELAY	16	Description	27
Description	16	Component Function Check	27
DTC Logic	16	Diagnosis Procedure	27
Diagnosis Procedure	16	ECU DIAGNOSIS INFORMATION	28
		AWD CONTROL UNIT	28
		Reference Value	28
		Wiring Diagram - AWD SYSTEM -	30
		Fail-Safe	34
		DTC Inspection Priority Chart	35

F

G

H

I

J

K

L

M

N

O

P

DTC Index	35	PERIODIC MAINTENANCE	49
SYMPTOM DIAGNOSIS	36	TRANSFER OIL	49
AWD WARNING LAMP DOES NOT TURN ON		Inspection	49
Description	36	Draining	49
Diagnosis Procedure	36	Refilling	49
AWD WARNING LAMP DOES NOT TURN OFF	37	REMOVAL AND INSTALLATION	51
Description	37	AWD CONTROL UNIT	51
Diagnosis Procedure	37	Exploded View	51
HEAVY TIGHT-CORNER BRAKING SYMPTOM OCCURS	38	Removal and Installation	51
Description	38	UNIT REMOVAL AND INSTALLATION	53
Diagnosis Procedure	38	TRANSFER ASSEMBLY	53
VEHICLE DOES NOT ENTER AWD MODE	39	Exploded View	53
Description	39	Removal and Installation	53
Diagnosis Procedure	39	UNIT DISASSEMBLY AND ASSEMBLY ...	55
AWD WARNING LAMP BLINKS QUICKLY	40	ADAPTER CASE	55
Description	40	Exploded View	55
AWD WARNING LAMP BLINKS SLOWLY	41	Disassembly	56
Description	41	Assembly	57
Diagnosis Procedure	41	Inspection After Disassembly	58
NOISE, VIBRATION AND HARSHNESS (NVH) TROUBLESHOOTING	42	GEAR RING	59
NVH Troubleshooting Chart	42	Exploded View	59
PRECAUTION	43	Disassembly	60
PRECAUTIONS	43	Assembly	61
FOR USA AND CANADA	43	Inspection After Disassembly	62
FOR USA AND CANADA : Precaution for Supplemental Restraint System (SRS) "AIR BAG" and "SEAT BELT PRE-TENSIONER"	43	DRIVE PINION	63
FOR USA AND CANADA : Precaution for Procedure without Cowl Top Cover	43	Exploded View	63
FOR USA AND CANADA : Service Notice or Precautions for Transfer	43	Disassembly	64
FOR MEXICO	44	Assembly	65
FOR MEXICO : Precaution for Supplemental Restraint System (SRS) "AIR BAG" and "SEAT BELT PRE-TENSIONER"	44	Adjustment	67
FOR MEXICO : Precaution for Procedure without Cowl Top Cover	44	Inspection After Disassembly	72
FOR MEXICO : Service Notice or Precautions for Transfer	45	TRANSFER CASE	74
PREPARATION	46	Exploded View	74
PREPARATION	46	Disassembly	75
Special Service Tool	46	Assembly	75
Commercial Service Tool	48	Inspection	77
		SERVICE DATA AND SPECIFICATIONS (SDS)	78
		SERVICE DATA AND SPECIFICATIONS (SDS)	78
		General Specifications	78
		Preload Torque	78
		Backlash	78
		Companion Flange Runout	78
		REAR PROPELLER SHAFT: 3F63A-EDJ75	
		SYMPTOM DIAGNOSIS	79
		NOISE, VIBRATION AND HARSHNESS (NVH) TROUBLESHOOTING	79

NVH Troubleshooting Chart	79	Refilling	92	
PREPARATION	80	REMOVAL AND INSTALLATION	93	A
PREPARATION	80	FRONT OIL SEAL	93	B
Commercial Service Tool	80	Exploded View	93	
PERIODIC MAINTENANCE	81	Removal and Installation	93	
REAR PROPELLER SHAFT	81	SIDE OIL SEAL	95	C
Inspection	81	Exploded View	95	
REMOVAL AND INSTALLATION	82	Removal and Installation	95	
REAR PROPELLER SHAFT	82	ELECTRIC CONTROLLED COUPLING	96	DLN
Exploded View	82	Exploded View	96	
Removal and Installation	82	Removal and Installation	96	
Inspection	84	UNIT REMOVAL AND INSTALLATION ...	100	E
SERVICE DATA AND SPECIFICATIONS (SDS)	85	REAR FINAL DRIVE ASSEMBLY	100	F
SERVICE DATA AND SPECIFICATIONS (SDS)	85	Exploded View	100	
General Specifications	85	Removal and Installation	100	
Propeller Shaft Runout	85	UNIT DISASSEMBLY AND ASSEMBLY .	103	G
Journal Axial Play	85	ELECTRIC CONTROLLED COUPLING	103	H
REAR FINAL DRIVE: R145		Exploded View	103	
SYSTEM DESCRIPTION	86	Disassembly	104	I
REAR FINAL DRIVE ASSEMBLY	86	Assembly	104	
System Diagram	86	Adjustment	106	
SYMPTOM DIAGNOSIS	87	Inspection After Disassembly	106	
NOISE, VIBRATION AND HARSHNESS (NVH) TROUBLESHOOTING	87	DIFFERENTIAL ASSEMBLY	108	J
NVH Troubleshooting Chart	87	Exploded View	108	
PRECAUTION	88	Disassembly	109	
PRECAUTIONS	88	Assembly	110	K
Service Notice or Precautions for Rear Final Drive...	88	Inspection After Disassembly	113	
PREPARATION	89	DRIVE PINION	115	L
PREPARATION	89	Exploded View	115	
Special Service Tools	89	Disassembly	116	
Commercial Service Tools	91	Assembly	117	
PERIODIC MAINTENANCE	92	Adjustment	120	
REAR DIFFERENTIAL GEAR OIL	92	Inspection After Disassembly	123	M
Inspection	92	SERVICE DATA AND SPECIFICATIONS (SDS)	125	N
Draining	92	SERVICE DATA AND SPECIFICATIONS (SDS)	125	O
		General Specification	125	
		Drive Gear Runout	125	
		Differential Side Gear Clearance	125	
		Preload Torque	125	
		Backlash	125	P
		Companion Flange Runout	125	

BASIC INSPECTION

DIAGNOSIS AND REPAIR WORK FLOW

Work Flow

INFOID:000000006260334

DETAILED FLOW

1. INTERVIEW FROM THE CUSTOMER

Clarify customer complaints before inspection. First of all, reproduce symptoms, and understand them fully. Ask customer about his/her complaints carefully. Check symptoms by driving vehicle with customer, if necessary.

CAUTION:

Customers are not professional. Never guess easily like “maybe the customer means that...,” or “maybe the customer mentions this symptom”.

>> GO TO 2.

2. CHECK AWD WARNING LAMP

Start the engine and drive at 30 km/h (19 MPH) or more for approximately 1 minute.

Does AWD warning lamp turn ON?

- YES >> GO TO 3.
- NO >> GO TO 6.

3. PERFORM SELF-DIAGNOSIS

Ⓟ With CONSULT-III

1. Perform self-diagnosis for “ALL MODE AWD/4WD”.
2. Check malfunction detected by self-diagnosis.
3. Erase self-diagnostic results for “ALL MODE AWD/4WD”.

>> GO TO 4.

4. CHECK TERMINALS AND HARNESS CONNECTORS

Check pin terminals for damage or loose connection with harness connector.

>> GO TO 5.

5. CHECK SYMPTOM REPRODUCTION

Ⓟ With CONSULT-III

Perform DTC reproduction procedure for the error system.

Is any error detected?

- YES >> GO TO 2.
- NO >> GO TO 6.

6. PERFORM SYMPTOM DIAGNOSIS

Perform the symptom diagnosis for each system.

Is any malfunction present?

- YES >> GO TO 2.
- NO >> GO TO 7.

7. FINAL CHECK

Ⓟ With CONSULT-III

Check input/output signal standard of “ALL MODE AWD/4WD”.

Is the input/output the standard value?

- YES >> INSPECTION END
- NO >> GO TO 2.

AWD SYSTEM

< SYSTEM DESCRIPTION >

[TRANSFER: TY20A]

SYSTEM DESCRIPTION

AWD SYSTEM

System Diagram

INFOID:000000006260335

CONTROL DIAGRAM

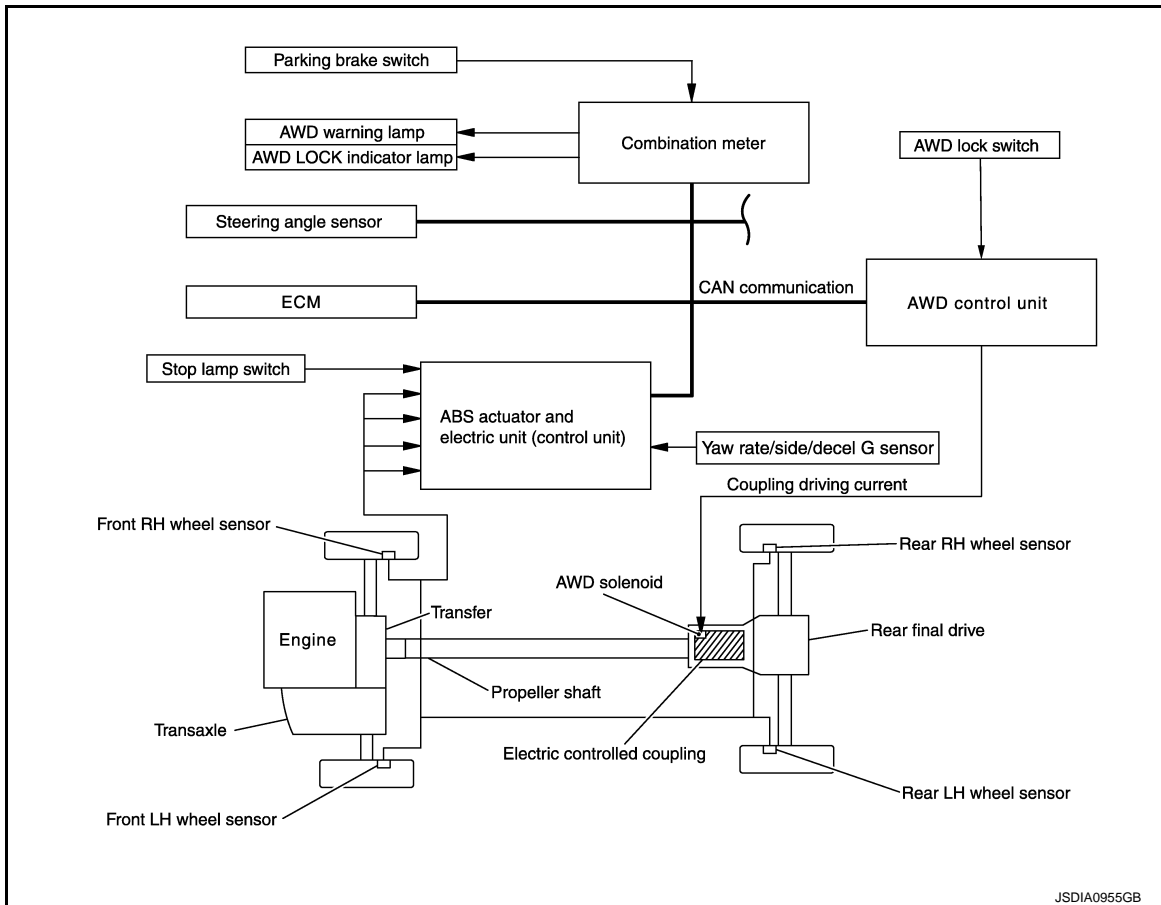

CROSS-SECTIONAL VIEW

A
B
C
DLN
E
F
G
H
I
J
K
L
M
N
O
P

AWD SYSTEM

< SYSTEM DESCRIPTION >

[TRANSFER: TY20A]

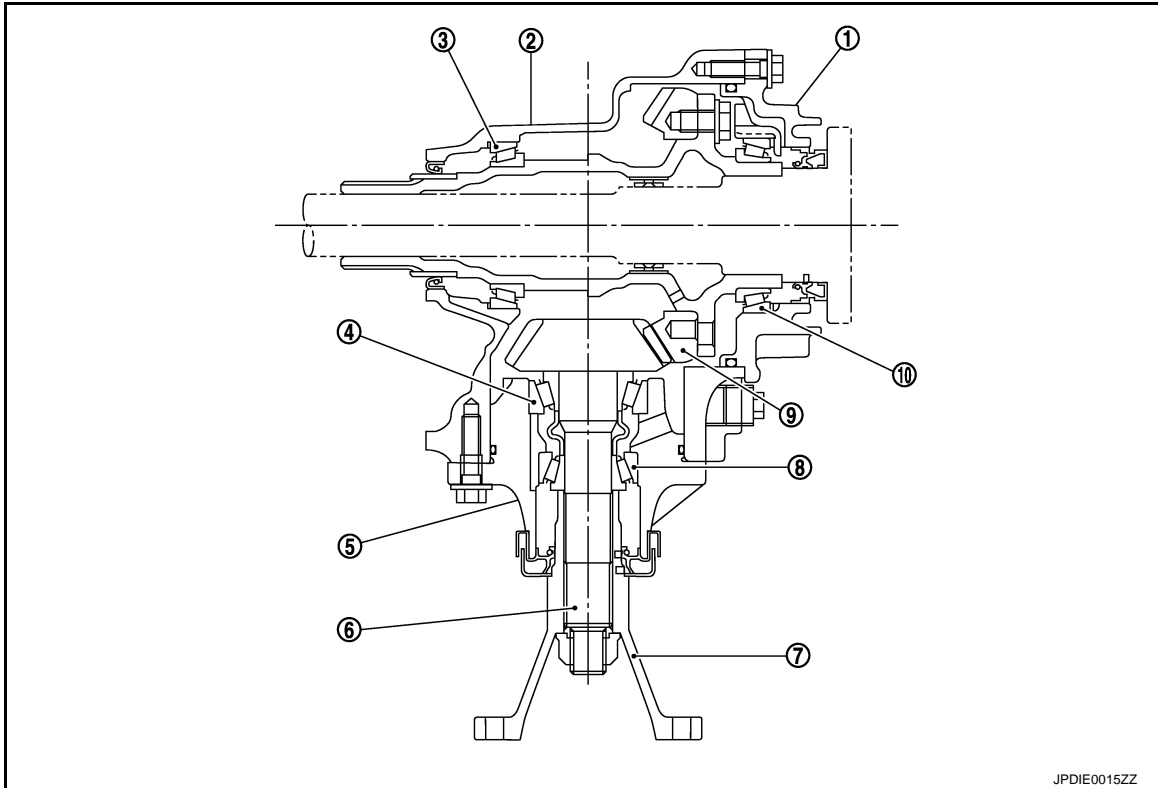

- | | | |
|---|------------------------|---|
| 1. Adapter case | 2. Transfer case | 3. Gear ring bearing (Transfer case side) |
| 4. Pinion front bearing | 5. Pinion sleeve | 6. Drive pinion |
| 7. Companion flange | 8. Pinion rear bearing | 9. Drive gear |
| 10. Gear ring bearing (Adapter case side) | | |

System Description

INFOID:0000000006260336

DESCRIPTION

- AWD controls distribution of drive power between front-wheel drive (100:0) and 4-wheel drive (50:50) conditions according to signals from sensors.
- By receiving the steering angle sensor signal, yaw rate sensor signal, side G sensor signal and decel G sensor signal, vehicle with VDC corrects a torque distribution for front and rear wheels according to a driving operation and a behavior of the vehicle during cornering and improves drivability and safety on a slippery road surface.
- It transmits/receives each signal from the following AWD control unit via CAN communication line.

Component parts	Function
ABS actuator and electric unit (control unit)	Transmits the following signals via CAN communication to AWD control unit. <ul style="list-style-type: none"> • Vehicle speed signal • Stop lamp switch signal (brake signal) • Yaw rate sensor signal • Side G sensor signal • Decel G sensor signal
ECM	Transmits the following signals via CAN communication to AWD control unit. <ul style="list-style-type: none"> • Accelerator pedal position signal • Engine speed signal

AWD SYSTEM

< SYSTEM DESCRIPTION >

[TRANSFER: TY20A]

Component parts	Function
Combination meter	Transmits conditions of parking brake switch signal via CAN communication to AWD control unit.
	Receives the following signals via CAN communication from AWD control unit. <ul style="list-style-type: none"> • AWD warning lamp signal • AWD LOCK indicator lamp signal
Steering angle sensor	Transmits conditions of steering angle sensor signal via CAN communication to AWD control unit.

AUTO Mode

- Electronic control allows optimal distribution of torque to front/rear wheels to match road conditions.
- AWD mode makes possible stable driving possible with no wheel spin, on snowy roads or other slippery surfaces.
- On roads which do not require 4-wheel drive, AUTO mode contributes to improved fuel economy by driving in conditions close to front-wheel drive.
- Sensor inputs determine the vehicle's turning condition, and tight cornering/braking are controlled by distributing optimum torque to rear wheels.

NOTE:

Light tight-corner braking symptom may occur depending on driving condition in AUTO mode. This is not malfunction.

LOCK Mode

- Front/rear wheel torque distribution is fixed, ensuring stable driving when climbing slopes.
- Vehicle will switch automatically to AUTO mode if vehicle speed increases. If vehicle speed then decreases, the vehicle automatically returns to direct 4-wheel driving conditions. The AWD LOCK indicator lamp keeps illuminating.
- LOCK mode will change to AUTO mode automatically, when the vehicle has been driven at a high speed. The AWD LOCK indicator lamp turns off.
- LOCK mode will change to AUTO mode automatically, when the ignition switch is turned "OFF".

NOTE:

- Every time AWD LOCK switch is pressed, AUTO mode and LOCK mode switch each other.
- If there is a significant difference in pressure or wear between tires, full vehicle performance is not available. Tire conditions are detected, and LOCK mode may be prohibited, or else speeds at which LOCK mode is enabled may be restricted.
- Heavy tight-corner braking symptom occurs when vehicle is driven in the following conditions: LOCK mode, steering wheel is turned fully to either sides, and accelerator pedal is depressed.

CAUTION:

Never switch to LOCK when rotation speed of front and rear wheel differs.

POWER TRANSFER DIAGRAM

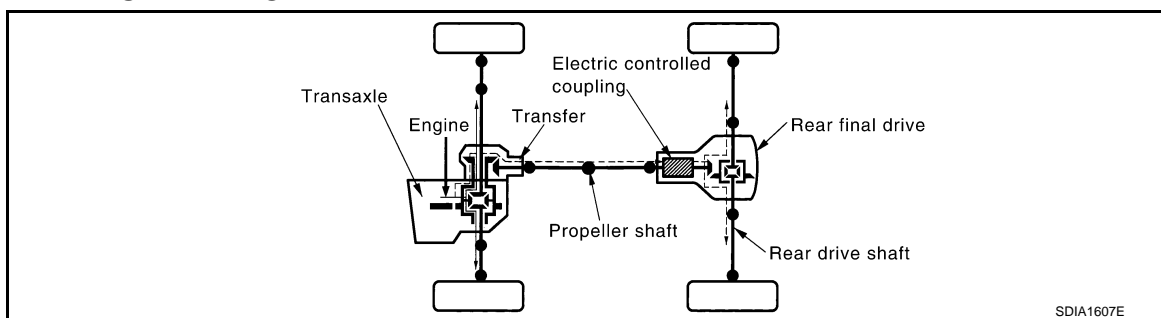

OPERATION PRINCIPLE

Electric Controlled Coupling

AWD SYSTEM

[TRANSFER: TY20A]

< SYSTEM DESCRIPTION >

1. The AWD control unit supplies command current to electric controlled coupling (AWD solenoid).
2. The control clutch is engaged by electromagnet and torque is detected in control clutch.
3. The cam operates in response to control clutch torque and applies pressure to main clutch.
4. The main clutch transmits torque to front wheels according to pressing power.

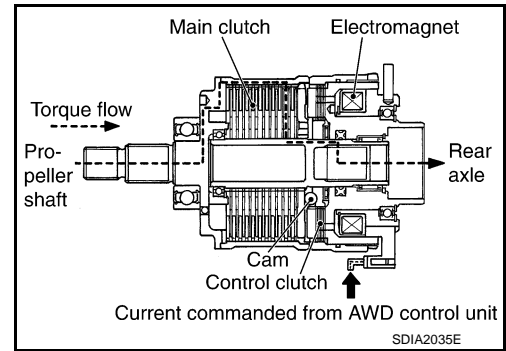

- Transmission torque to the rear wheels is determined according to command current.

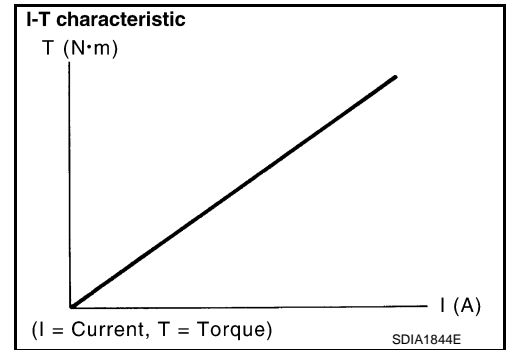

Component Parts Location

INFOID:000000006260337

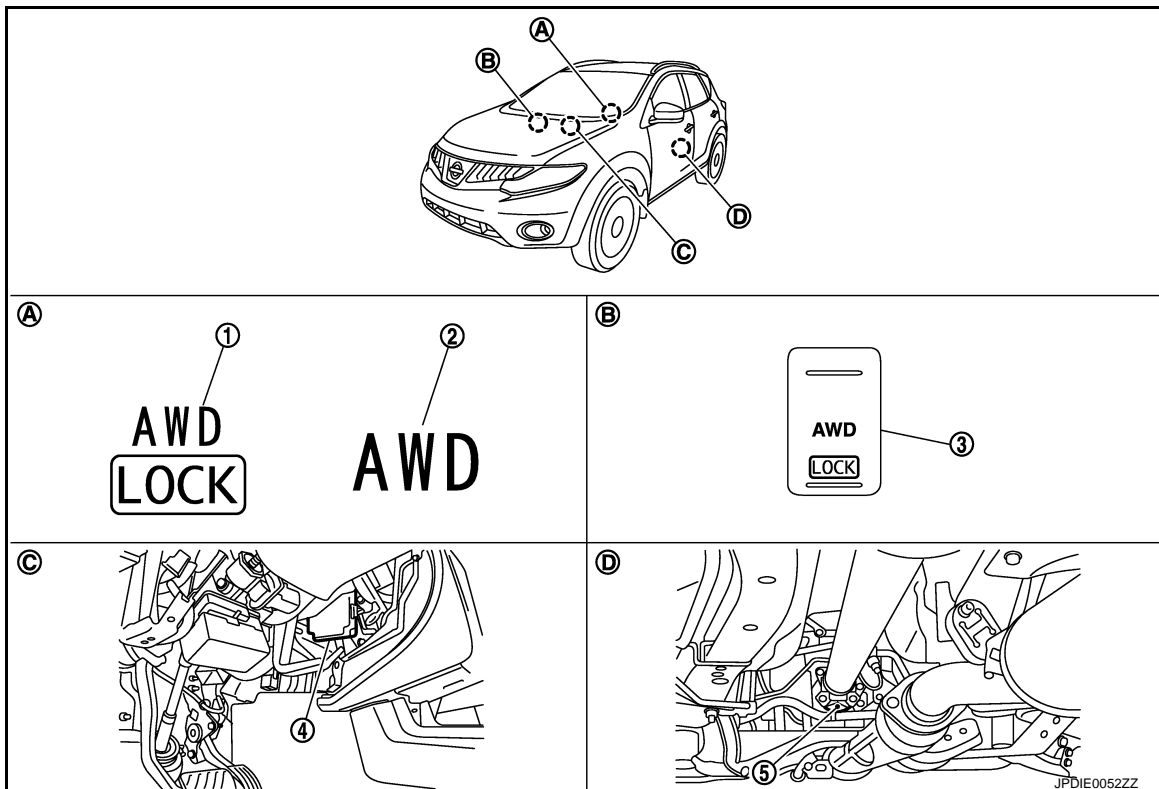

- | | | |
|------------------------------|---------------------------------------|--|
| 1. AWD LOCK indicator lamp | 2. AWD warning lamp | 3. AWD lock switch |
| 4. AWD control unit | 5. AWD solenoid (in rear final drive) | |
| A. Combination meter | B. Center console (Front side) | C. Instrument driver lower cover removed |
| D. Rear final drive assembly | | |

AWD SYSTEM

< SYSTEM DESCRIPTION >

[TRANSFER: TY20A]

Component Description

INFOID:000000006260338

Component parts	Reference/Function
AWD control unit	DLN-12. "Description"
Wheel sensors	BRC-33. "Description"
AWD solenoid	DLN-14. "Description"
Electric controlled coupling	Transmits driving force to rear final drive.
AWD warning lamp	DLN-25. "Description"
AWD LOCK indicator lamp	DLN-27. "Description"
AWD lock switch	DLN-23. "Description"
ABS actuator and electric unit (control unit)	DLN-13. "Description"
ECM	DLN-18. "Description"
Combination meter	DLN-27. "Description"
Steering angle sensor	BRC-69. "Description"

A
B
C
DLN
E
F
G
H
I
J
K
L
M
N
O
P

DIAGNOSIS SYSTEM (AWD CONTROL UNIT)

< SYSTEM DESCRIPTION >

[TRANSFER: TY20A]

DIAGNOSIS SYSTEM (AWD CONTROL UNIT)

CONSULT-III Function

INFOID:000000006260339

FUNCTION

CONSULT-III can display each diagnostic item using the diagnostic test modes as follows.

Diagnostic test mode	Function
ECU Identification	AWD control unit part number can be read.
Self Diagnostic Result	Self-diagnostic results can be read and erased quickly.
Data Monitor	Input/Output data in the AWD control unit can be read.
Active Test	Diagnostic Test Mode in which CONSULT-III drives some actuators apart from the AWD control unit and also shifts some parameters in a specified range.

ECU IDENTIFICATION

AWD control unit part number can be read.

SELF -DIAGNOSTIC RESULT

Before performing the self-diagnosis, start the engine and drive vehicle at 30 km/h (19 MPH) or more for approximately 1 minute.

Display Item List

Refer to [DLN-35, "DTC Index"](#).

How to Erase Self-Diagnostic Results

Before erasing DTC memory, start the engine and drive at 30 km/h (19 MPH) or more for approximately 1 minute. Check that ABS warning lamp turns OFF.

NOTE:

When AWD warning lamp is ON with system malfunction of DTC "C1203", run the vehicle at 30 km/h (19 MPH) or more for a minute and check that ABS warning lamp is turned OFF. Then turn ignition switch OFF, and start the engine again. Otherwise AWD warning lamp may not turned OFF even if it is normal.

DATA MONITOR

Display Item List

Monitor item (Unit)	Remarks
STOP LAMP SW [On/Off]	Stop lamp switch signal status via CAN communication line is displayed.
ENG SPEED SIG [Run/Stop]	Engine status is displayed.
ETS ACTUATOR [On/Off]	Operating condition of AWD actuator relay (integrated in AWD control unit) is displayed.
4WD WARN LAMP [On/Off]	Control status of AWD warning lamp is displayed.
4WD MODE SW [AUTO/LOCK]	Mode switch is not equipped, but displayed.
4WD MODE MON [AUTO/LOCK]	Control status of AWD is displayed.
DIS-TIRE MONI [mm]	Improper size tire installed condition is displayed.
P BRAKE SW [On/Off]	Parking switch signal status via CAN communication line is displayed.
BATTERY VOLT [V]	Power supply voltage for AWD control unit
THRTL POS SEN [%]	Throttle opening status is displayed.
ETS SOLENOID [A]	Monitored value of current at AWD solenoid
FR RH SENSOR [km/h] or [mph]	Wheel speed calculated by front RH wheel sensor signal is displayed.
FR LH SENSOR [km/h] or [mph]	Wheel speed calculated by front LH wheel sensor signal is displayed.
RR RH SENSOR [km/h] or [mph]	Wheel speed calculated by rear RH wheel sensor signal is displayed.
RR LH SENSOR [km/h] or [mph]	Wheel speed calculated by rear LH wheel sensor signal is displayed.

ACTIVE TEST

Description

DIAGNOSIS SYSTEM (AWD CONTROL UNIT)

< SYSTEM DESCRIPTION >

[TRANSFER: TY20A]

Use this mode to determine and identify the details of a malfunction based on self-diagnostic results or data monitor. AWD control unit gives drive signal to actuator with receiving command from CONSULT-III to check operation of actuator.

Test Item

Test item	Condition	Description
ETS S/V (Detects AWD solenoid)	<ul style="list-style-type: none">• Vehicle stopped• Engine running• No DTC detected	<p>Change command current value to AWD solenoid, and then change driving mode. (Monitor value is normal if it is within approx. $\pm 10\%$ of command value.)</p> <ul style="list-style-type: none">• Qu: Increase current value in increments of 0.2 A• Qd: Decrease current value in increments of 0.2 A• UP: Increase current value in increments of 0.02 A• DOWN: Decrease current value in increments of 0.02 A

CAUTION:

Never energize continuously for a long time.

A
B
C
DLN
E
F
G
H
I
J
K
L
M
N
O
P

DTC/CIRCUIT DIAGNOSIS

C1201 AWD CONTROL UNIT

Description

INFOID:000000006260340

- Controls driving force distribution by signals from each sensor from front wheel driving mode (100:0) to 4-wheel driving mode (50:50).
- Front wheel driving conditions is available by fail-safe function if malfunction is detected in AWD system.

DTC Logic

INFOID:000000006260341

DTC DETECTION LOGIC

DTC	Display item	Malfunction detected condition	Possible cause
C1201	CONTROLLER FAILURE	Malfunction has occurred inside AWD control unit.	Internal malfunction of AWD control unit

DTC CONFIRMATION PROCEDURE

1. DTC REPRODUCTION PROCEDURE

With CONSULT-III

1. Turn the ignition switch OFF to ON.
2. Perform self-diagnosis for "ALL MODE AWD/4WD".

Is DTC "C1201" detected?

- YES >> Proceed to diagnosis procedure. Refer to [DLN-12, "Diagnosis Procedure"](#).
 NO >> INSPECTION END

Diagnosis Procedure

INFOID:000000006260342

1. PERFORM SELF-DIAGNOSIS

With CONSULT-III

1. Erase self-diagnostic results for "ALL MODE AWD/4WD".
2. Turn the ignition switch OFF, and then wait 10 seconds or more.
3. Perform self-diagnosis for "ALL MODE AWD/4WD".

Is DTC "C1201" detected?

- YES >> Replace AWD control unit. Refer to [DLN-51, "Exploded View"](#).
 NO >> Check AWD control unit pin terminals for damage or loose connection with harness connector. If any items are damaged, repair or replace error-detected parts.

C1203 ABS ACTUATOR AND ELECTRIC UNIT (CONTROL UNIT)

< DTC/CIRCUIT DIAGNOSIS >

[TRANSFER: TY20A]

C1203 ABS ACTUATOR AND ELECTRIC UNIT (CONTROL UNIT)

Description

INFOID:000000006260343

- Transmits the following signals via CAN communication to AWD control unit.
- Vehicle speed signal
- Stop lamp switch signal (brake signal)
- Yaw rate sensor signal
- Side G sensor signal
- Decel G sensor signal

DTC Logic

INFOID:000000006260344

DTC DETECTION LOGIC

DTC	Display item	Malfunction detected condition	Possible cause
C1203	ABS SYSTEM	Malfunction related to wheel sensor has been detected by ABS actuator and electric unit (control unit).	ABS malfunction <ul style="list-style-type: none">• Vehicle speed signal error

DTC CONFIRMATION PROCEDURE

1. DTC REPRODUCTION PROCEDURE

With CONSULT-III

1. Start the engine and drive at 30 km/h (19 MPH) or more for approximately 1 minute.
2. Perform self-diagnosis for "ALL MODE AWD/4WD".

Is DTC "C1203" detected?

- YES >> Proceed to diagnosis procedure. Refer to [DLN-13, "Diagnosis Procedure"](#).
NO >> INSPECTION END

Diagnosis Procedure

INFOID:000000006260345

1. PERFORM ABS ACTUATOR AND ELECTRIC UNIT (CONTROL UNIT) SELF-DIAGNOSIS

With CONSULT-III

Perform self-diagnosis for "ABS".

Is any DTC detected?

- YES >> Check the DTC.
NO >> GO TO 2.

2. PERFORM SELF-DIAGNOSIS

With CONSULT-III

1. Erase self-diagnostic results for "ALL MODE AWD/4WD".
2. Start the engine and drive vehicle at 30 km/h (19 MPH) or more for approximately 1 minute.
3. Check that ABS warning lamp turns OFF.
4. Perform self-diagnosis for "ALL MODE AWD/4WD".

Is DTC "C1203" detected?

- YES >> Replace AWD control unit. Refer to [DLN-51, "Exploded View"](#).
NO >> Check AWD control unit pin terminals for damage or loose connection with harness connector. If any items are damaged, repair or replace error-detected parts.

C1204 AWD SOLENOID

< DTC/CIRCUIT DIAGNOSIS >

[TRANSFER: TY20A]

C1204 AWD SOLENOID

Description

INFOID:000000006260346

Controls electric controlled coupling by command current from AWD control unit.

DTC Logic

INFOID:000000006260347

DTC DETECTION LOGIC

DTC	Display item	Malfunction detected condition	Possible cause
C1204	4WD SOLENOID	Malfunction related to AWD solenoid has been detected.	<ul style="list-style-type: none">Internal malfunction of electronic controlled couplingMalfunction of AWD solenoid power supply circuit (open or short)Malfunction of AWD solenoid command current

DTC CONFIRMATION PROCEDURE

1. DTC REPRODUCTION PROCEDURE

With CONSULT-III

- Turn the ignition switch OFF to ON.
- Perform self-diagnosis for "ALL MODE AWD/4WD".

Is DTC "C1204" detected?

- YES >> Proceed to diagnosis procedure. Refer to [DLN-14, "Diagnosis Procedure"](#).
NO >> INSPECTION END

Diagnosis Procedure

INFOID:000000006260348

1. CHECK AWD SOLENOID POWER SUPPLY

- Turn the ignition switch OFF.
- Disconnect AWD control unit harness connector.
- Check the voltage between AWD control unit harness connector and ground.

AWD control unit		—	Voltage
Connector	Terminal		
M69	9	Ground	Battery voltage

Is the inspection result normal?

- YES >> GO TO 2.
NO >> Perform the trouble diagnosis for power supply circuit. Refer to [DLN-21, "Diagnosis Procedure"](#).

2. CHECK AWD SOLENOID GROUND

Check the continuity between AWD control unit harness connector and ground.

AWD control unit		—	Continuity
Connector	Terminal		
M69	10	Ground	Existed
	11		

Is the inspection result normal?

- YES >> GO TO 3.
NO >> Repair or replace error-detected parts.

3. CHECK AWD SOLENOID CIRCUIT

- Check the continuity between AWD control unit harness connector and AWD solenoid harness connector.

C1204 AWD SOLENOID

< DTC/CIRCUIT DIAGNOSIS >

[TRANSFER: TY20A]

AWD control unit		AWD solenoid		Continuity
Connector	Terminal	Connector	Terminal	
M69	1	C1	1	Existed
	2		2	

2. Check the continuity between AWD control unit harness connector and the ground.

AWD control unit		—	Continuity
Connector	Terminal		
M69	1	Ground	Not existed
	2		

3. Check the continuity between AWD solenoid harness connector and the ground.

AWD solenoid		—	Continuity
Connector	Terminal		
C1	1	Ground	Not existed
	2		

Is the inspection result normal?

YES >> GO TO 4.

NO >> Repair or replace error-detected parts.

4.CHECK AWD SOLENOID

Check AWD solenoid. Refer to [DLN-15, "Component Inspection"](#).

Is the inspection result normal?

YES >> GO TO 5.

NO >> AWD solenoid is malfunctioning. Replace electric controlled coupling. Refer to [DLN-96, "Exploded View"](#).

5.CHECK TERMINALS AND HARNESS CONNECTORS

1. Check AWD control unit pin terminals for damage or loose connection with harness connector.

2. Check AWD solenoid pin terminals for damage or loose connection with harness connector.

Is the inspection result normal?

YES >> Replace AWD control unit. Refer to [DLN-51, "Exploded View"](#).

NO >> Repair or replace error-detected parts.

Component Inspection

INFOID:000000006260349

1.CHECK AWD SOLENOID

1. Turn the ignition switch OFF.

2. Disconnect AWD solenoid harness connector.

3. Check the resistance between AWD solenoid harness connector terminals.

AWD solenoid		Resistance (Approx.)
Terminal		
1	2	2.45 Ω

Is the inspection result normal?

YES >> INSPECTION END

NO >> AWD solenoid is malfunctioning. Replace electric controlled coupling. Refer to [DLN-96, "Exploded View"](#).

C1205 AWD ACTUATOR RELAY

< DTC/CIRCUIT DIAGNOSIS >

[TRANSFER: TY20A]

C1205 AWD ACTUATOR RELAY

Description

INFOID:000000006260350

AWD solenoid is supplied with voltage by the internal circuit of AWD control unit.

DTC Logic

INFOID:000000006260351

DTC DETECTION LOGIC

DTC	Display item	Malfunction detected condition	Possible cause
C1205	4WD ACTUATOR RLY	Malfunction has been detected from AWD actuator relay integrated with AWD control unit, or malfunction related to AWD solenoid has been detected.	<ul style="list-style-type: none">Internal malfunction of AWD control unitMalfunction of AWD solenoid power supply circuit (open or short)

DTC CONFIRMATION PROCEDURE

1. DTC REPRODUCTION PROCEDURE

With CONSULT-III

- Turn the ignition switch OFF to ON.
- Perform self-diagnosis for "ALL MODE AWD/4WD".

Is DTC "C1205" detected?

- YES >> Proceed to diagnosis procedure. Refer to [DLN-16, "Diagnosis Procedure"](#).
NO >> INSPECTION END

Diagnosis Procedure

INFOID:000000006260352

1. CHECK AWD SOLENOID CIRCUIT (1)

- Turn the ignition switch OFF.
- Disconnect AWD control unit harness connector.
- Check the continuity between AWD control unit harness connector and the ground.

AWD control unit		—	Continuity
Connector	Terminal		
M69	1	Ground	Not existed
	2		

Is the inspection result normal?

- YES >> GO TO 2.
NO >> GO TO 3.

2. CHECK TERMINALS AND HARNESS CONNECTORS

- Check AWD control unit pin terminals for damage or loose connection with harness connector.
- Check AWD solenoid pin terminals for damage or loose connection with harness connector.

Is the inspection result normal?

- YES >> After connecting each harness connector, perform DTC confirmation procedure again. When DTC "C1205" is detected, replace AWD control unit. Refer to [DLN-51, "Exploded View"](#).
NO >> Repair or replace damaged parts.

3. CHECK AWD SOLENOID

- Disconnect AWD solenoid harness connector.
- Check the continuity between AWD solenoid harness connector and the ground.

C1205 AWD ACTUATOR RELAY

< DTC/CIRCUIT DIAGNOSIS >

[TRANSFER: TY20A]

AWD solenoid		
Terminal	—	Continuity
1	Ground	Not existed
2		

A

B

Is the inspection result normal?

YES >> GO TO 4.

NO >> AWD solenoid is malfunctioning. Replace electric controlled coupling. Refer to [DLN-96. "Exploded View"](#).

C

4. CHECK AWD SOLENOID CIRCUIT

DLN

Check the continuity between AWD control unit harness connector and the ground.

AWD control unit			
Connector	Terminal	—	Continuity
M69	1	Ground	Not existed
	2		

E

F

Is the inspection result normal?

YES >> GO TO 5.

NO >> Repair or replace damaged parts.

G

5. CHECK TERMINALS AND HARNESS CONNECTORS

H

1. Check AWD control unit pin terminals for damage or loose connection with harness connector.
2. Check AWD solenoid pin terminals for damage or loose connection with harness connector.

Is the inspection result normal?

YES >> After connecting each harness connector, perform DTC confirmation procedure again. When DTC "C1205" is detected, GO TO 1.

NO >> Repair or replace damaged parts.

I

J

K

L

M

N

O

P

C1210 ECM

Description

INFOID:000000006260353

Transmits the following signals via CAN communication to AWD control unit.

- Accelerator pedal position signal
- Engine speed signal

DTC Logic

INFOID:000000006260354

DTC DETECTION LOGIC

DTC	Display item	Malfunction detected condition	Possible cause
C1210	ENGINE SIGNAL 1	Malfunction related to engine signal has been detected.	Malfunction of engine control system

DTC CONFIRMATION PROCEDURE

1. DTC REPRODUCTION PROCEDURE

 **With CONSULT-III**

1. Start the engine. Drive the vehicle for a while.
2. Perform self-diagnosis for "ALL MODE AWD/4WD".

Is DTC "C1210" detected?

- YES >> Proceed to diagnosis procedure. Refer to [DLN-18, "Diagnosis Procedure"](#).
 NO >> INSPECTION END

Diagnosis Procedure

INFOID:000000006260355

1. PERFORM ECM SELF-DIAGNOSIS

 **With CONSULT-III**

Perform self-diagnosis for "ENGINE".

Is any DTC detected?

- YES >> Check the DTC.
 NO >> GO TO 2.

2. PERFORM SELF-DIAGNOSIS

 **With CONSULT-III**

1. Erase self-diagnostic results for "ALL MODE AWD/4WD".
2. Turn the ignition switch OFF.
3. Start the engine. Drive the vehicle for a while.
4. Check that malfunction indicator lamp (MIL) turns OFF.
5. Stop the vehicle. Perform self-diagnosis for "ALL MODE AWD/4WD".

Is DTC "C1210" detected?

- YES >> Replace AWD control unit. Refer to [DLN-51, "Exploded View"](#).
 NO >> Check AWD control unit pin terminals for damage or loose connection with harness connector. If any items are damaged, repair or replace error-detected parts.

U1000 CAN COMM CIRCUIT

Description

INFOID:000000006260356

CAN (Controller Area Network) is a serial communication line for real time application. It is an on-vehicle multiplex communication line with high data communication speed and excellent error detection ability. Many electronic control units are equipped onto a vehicle, and each control unit shares information and links with other control units during operation (not independent). In CAN communication, control units are connected with 2 communication lines (CAN-H line, CAN-L line) allowing a high rate of information transmission with less wiring. Each control unit communicate data but selectively reads required data only.

DTC Logic

INFOID:000000006260357

DTC DETECTION LOGIC

DTC	Display item	Malfunction detected condition	Possible cause
U1000	CAN COMM CIRCUIT	AWD control unit is not transmitting/receiving CAN communication signal for 2 seconds or more.	<ul style="list-style-type: none"> • CAN communication error • Malfunction of AWD control unit

DTC CONFIRMATION PROCEDURE

1. DTC REPRODUCTION PROCEDURE

With CONSULT-III

1. Turn the ignition switch OFF to ON.
2. Perform self-diagnosis for "ALL MODE AWD/4WD".

Is DTC "U1000" detected?

- YES >> Proceed to diagnosis procedure. Refer to [DLN-19, "Diagnosis Procedure"](#).
 NO >> INSPECTION END

Diagnosis Procedure

INFOID:000000006260358

1. PERFORM SELF-DIAGNOSIS

With CONSULT-III

Perform self-diagnosis for "ALL MODE AWD/4WD".

Is DTC "U1000" detected?

- YES >> Proceed to [LAN-15, "Trouble Diagnosis Flow Chart"](#).
 NO >> INSPECTION END

U1010 CONTROL UNIT (CAN)

< DTC/CIRCUIT DIAGNOSIS >

[TRANSFER: TY20A]

U1010 CONTROL UNIT (CAN)

Description

INFOID:000000006260359

CAN (Controller Area Network) is a serial communication line for real time application. It is an on-vehicle multiplex communication line with high data communication speed and excellent error detection ability. Many electronic control units are equipped onto a vehicle, and each control unit shares information and links with other control units during operation (not independent). In CAN communication, control units are connected with 2 communication lines (CAN-H line, CAN-L line) allowing a high rate of information transmission with less wiring. Each control unit communicate data but selectively reads required data only.

DTC Logic

INFOID:000000006260360

DTC DETECTION LOGIC

DTC	Display item	Malfunction detected condition	Possible cause
U1010	CONTROL UNIT (CAN)	Detecting error during the initial diagnosis of CAN controller of AWD control unit.	Malfunction of AWD control unit

DTC CONFIRMATION PROCEDURE

1. DTC REPRODUCTION PROCEDURE

Ⓔ With CONSULT-III

1. Turn the ignition switch OFF to ON.
2. Perform self-diagnosis for "ALL MODE AWD/4WD".

Is DTC "U1010" detected?

- YES >> Proceed to diagnosis procedure. Refer to [DLN-20, "Diagnosis Procedure"](#).
NO >> INSPECTION END

Diagnosis Procedure

INFOID:000000006260361

1. CHECK AWD CONTROL UNIT

Check AWD control unit harness connector for disconnection and deformation.

Is the inspection result normal?

- YES >> Replace AWD control unit. Refer to [DLN-51, "Exploded View"](#).
NO >> Repair or replace error-detected parts.

POWER SUPPLY AND GROUND CIRCUIT

< DTC/CIRCUIT DIAGNOSIS >

[TRANSFER: TY20A]

POWER SUPPLY AND GROUND CIRCUIT

Description

INFOID:000000006260362

Supplies power to AWD control unit.

Diagnosis Procedure

INFOID:000000006260363

1. CHECK AWD CONTROL UNIT POWER SUPPLY (1)

1. Turn the ignition switch OFF.
2. Disconnect AWD control unit harness connector.
3. Check the voltage between AWD control unit harness connector and ground.

AWD control unit		—	Voltage (Approx.)
Connector	Terminal		
M69	7	Ground	0 V

4. Turn the ignition switch ON.
CAUTION:
Never start the engine.
5. Check the voltage between AWD control unit harness connector and ground.

AWD control unit		—	Voltage
Connector	Terminal		
M69	7	Ground	Battery voltage

Is the inspection result normal?

- YES >> GO TO 3.
NO >> GO TO 2.

2. CHECK AWD CONTROL UNIT POWER SUPPLY (2)

1. Turn the ignition switch OFF.
2. Check the 10A fuse (#45).
3. Disconnect IPDM E/R harness connector.
4. Check the continuity between AWD control unit harness connector and IPDM E/R harness connector.

AWD control unit		IPDM E/R		Continuity
Connector	Terminal	Connector	Terminal	
M69	7	E10	26	Existed

5. Check the continuity between AWD control unit harness connector and the ground.

AWD control unit		—	Continuity
Connector	Terminal		
M69	7	Ground	Not existed

Is the inspection result normal?

- YES >> Perform the trouble diagnosis for ignition power supply circuit. Refer to [PG-63, "Wiring Diagram - IGNITION POWER SUPPLY -"](#).
- NO >> Repair or replace error-detected parts.

3. CHECK AWD SOLENOID POWER SUPPLY (1)

1. Turn the ignition switch OFF.
2. Disconnect AWD solenoid harness connector.
3. Check the voltage between AWD control unit harness connector and ground.

POWER SUPPLY AND GROUND CIRCUIT

< DTC/CIRCUIT DIAGNOSIS >

[TRANSFER: TY20A]

AWD control unit		—	Voltage
Connector	Terminal		
M69	9	Ground	Battery voltage

4. Turn the ignition switch ON.

CAUTION:

Never start the engine.

5. Check the voltage between AWD control unit harness connector and ground.

AWD control unit		—	Voltage
Connector	Terminal		
M69	9	Ground	Battery voltage

Is the inspection result normal?

YES >> GO TO 5.

NO >> GO TO 4.

4. CHECK AWD SOLENOID POWER SUPPLY (2)

1. Turn the ignition switch OFF.

2. Check the 10A fuse (#36).

Is the inspection result normal?

YES >> Perform the trouble diagnosis for power supply circuit. Refer to [PG-6. "Wiring Diagram - BATTERY POWER SUPPLY -"](#).

NO >> Repair or replace error-detected parts.

5. CHECK AWD CONTROL UNIT GROUND

1. Turn the ignition switch OFF.

2. Check the continuity between AWD control unit harness connector and ground.

AWD control unit		—	Continuity
Connector	Terminal		
M69	10	Ground	Existed
	11		

Is the inspection result normal?

YES >> INSPECTION END

NO >> Repair or replace error-detected parts.

AWD LOCK SWITCH

< DTC/CIRCUIT DIAGNOSIS >

[TRANSFER: TY20A]

AWD LOCK SWITCH

Description

INFOID:000000006260364

Able to select AUTO or LOCK mode.

Component Function Check

INFOID:000000006260365

1.CHECK AWD LOCK SWITCH OPERATION

Check that AWD LOCK indicator lamp is in a condition as shown in the following table.

Condition	AWD LOCK indicator lamp
When the switch is pressed in AWD mode.	ON
When the switch is pressed in 2WD mode.	OFF

Is the inspection result normal?

YES >> INSPECTION END

NO >> Proceed to diagnosis procedure. Refer to [DLN-23, "Diagnosis Procedure"](#).

Diagnosis Procedure

INFOID:000000006260366

1.CHECK AWD LOCK SWITCH

Check AWD lock switch. Refer to [DLN-24, "Component Inspection"](#).

Is the inspection result normal?

YES >> GO TO 2.

NO >> Replace AWD lock switch.

2.CHECK AWD LOCK SWITCH CIRCUIT (1)

Check the continuity between AWD lock switch harness connector and ground.

AWD lock switch		—	Continuity
Connector	Terminal		
M8	3	Ground	Existed

Is the inspection result normal?

YES >> GO TO 3.

NO >> Repair or replace error-detected parts.

3.CHECK AWD LOCK SWITCH CIRCUIT (2)

1. Disconnect AWD control unit harness connector.
2. Check the continuity between AWD control unit harness connector and AWD lock switch harness connector.

AWD control unit		AWD lock switch		Continuity
Connector	Terminal	Connector	Terminal	
M69	14	M8	1	Existed

3. Check the continuity between AWD control unit harness connector and ground.

AWD control unit		—	Continuity
Connector	Terminal		
M69	14	Ground	Not existed

Is the inspection result normal?

YES >> GO TO 4.

AWD LOCK SWITCH

[TRANSFER: TY20A]

< DTC/CIRCUIT DIAGNOSIS >

NO >> Repair or replace error-detected parts.

4.CHECK AWD CONTROL UNIT OUTPUT SIGNAL

1. Connect AWD control unit harness connector.
2. Turn the ignition switch ON.

CAUTION:

Never start the engine.

3. Check the voltage between AWD lock switch harness connector and ground.

AWD lock switch		—	Voltage
Connector	Terminal		
M8	1	Ground	Battery voltage

Is the inspection result normal?

- YES >> Check each harness connector pin terminal for disconnection.
NO >> Replace AWD control unit. Refer to [DLN-51. "Exploded View"](#).

Component Inspection

INFOID:000000006260367

1.CHECK AWD LOCK SWITCH

1. Turn the ignition switch OFF.
2. Remove AWD lock switch.
3. Check the continuity between AWD lock switch connector terminals.

AWD lock switch		Condition	Continuity
Terminal			
1	3	When releasing AWD lock switch.	Not existed
		When AWD lock switch is hold pressed.	Existed

Is the inspection result normal?

- YES >> INSPECTION END
NO >> Replace AWD lock switch.

AWD WARNING LAMP

< DTC/CIRCUIT DIAGNOSIS >

[TRANSFER: TY20A]

AWD WARNING LAMP

Description

INFOID:000000006260368

- Turns ON when there is a malfunction in AWD system. AWD warning lamp indicates the vehicle is in fail-safe mode and shifting to front-wheel drive or 4-wheel drive (rear-wheels still have some driving torque).
- Also turns ON when ignition switch is turned ON, for the purpose of lamp check. Turns OFF after the engine starts if system is normal.

AWD WARNING LAMP INDICATION

Condition	AWD warning lamp
Lamp check	Turns ON when ignition switch is turned ON. Turns OFF after the engine start.
AWD system malfunction	ON
Protection function is activated due to heavy load to electric controlled coupling. (AWD system is not malfunctioning and AWD system changes to front wheel drive.)	Quick blinking: 2 times/second (Blinking in approx. 1 minute and then turning OFF)
Large difference in diameter of front/rear tires	Slow blinking: 1 time/2 seconds (Continuing to blink until turning ignition switch OFF)
Other than above (system normal)	OFF

CAUTION:

- AWD warning lamp also turns ON due to data reception error, CAN communication error etc.

Component Function Check

INFOID:000000006260369

1. CHECK AWD WARNING LAMP FUNCTION

1. Turn ignition switch ON.
2. Check that AWD warning lamp lights up.

Is the inspection result normal?

YES >> INSPECTION END

NO >> Proceed to diagnosis procedure. Refer to [DLN-25, "Diagnosis Procedure"](#).

Diagnosis Procedure

INFOID:000000006260370

1. CHECK POWER SUPPLY AND GROUND CIRCUIT

Perform the trouble diagnosis for power supply and ground circuit. Refer to [DLN-21, "Diagnosis Procedure"](#).

Is the inspection result normal?

YES >> GO TO 2.

NO >> Repair or replace the error-detected parts.

2. PERFORM SELF-DIAGNOSIS

With CONSULT-III

Perform self-diagnosis for "ALL MODE AWD/4WD".

Is any detected?

YES >> Check the DTC.

NO >> GO TO 3.

3. CHECK AWD WARNING LAMP SIGNAL

With CONSULT-III

1. Turn the ignition switch ON.

CAUTION:

Never start the engine.

2. Check "4WD WARN LAMP" of CONSULT-III "DATA MONITOR" for "ALL MODE AWD/4WD".

Does the item on "DATA MONITOR" indicate "On"?

YES >> GO TO 4.

AWD WARNING LAMP

[TRANSFER: TY20A]

< DTC/CIRCUIT DIAGNOSIS >

NO >> Replace AWD control unit. Refer to [DLN-51, "Exploded View"](#).

4. CHECK COMBINATION METER POWER SUPPLY CIRCUIT

Perform the trouble diagnosis for combination meter power supply circuit. Refer to [MWI-44, "COMBINATION METER : Diagnosis Procedure"](#).

Is the inspection result normal?

YES >> INSPECTION END

NO >> Repair or replace the error-detected parts.

AWD LOCK INDICATOR LAMP

< DTC/CIRCUIT DIAGNOSIS >

[TRANSFER: TY20A]

AWD LOCK INDICATOR LAMP

Description

INFOID:000000006260371

The following is the indications of indicator lamp after the engine start.

AWD LOCK INDICATOR LAMP

Condition	AWD LOCK indicator lamp
Lamp check	Turns ON for approx. 1 second when ignition switch is turned ON.
AUTO mode	OFF
LOCK mode	ON

Component Function Check

INFOID:000000006260372

1. AWD LOCK INDICATOR LAMP OPERATION CHECK 1

Check that AWD LOCK indicator lamp turns on for approximately 1 second after the ignition switch is turned ON.

Is the inspection result normal?

YES >> INSPECTION END

NO >> Proceed to diagnosis procedure. Refer to [DLN-27, "Diagnosis Procedure"](#).

Diagnosis Procedure

INFOID:000000006260373

1. CHECK AWD WARNING LAMP

Start the engine and drive at 30 km/h (19 MPH) or more for approximately 1 minute.

Does AWD warning lamp turn ON?

YES >> Proceed to [DLN-25, "Diagnosis Procedure"](#).

NO >> GO TO 2.

2. CHECK AWD LOCK SWITCH

Perform the trouble diagnosis for AWD lock switch. Refer to [DLN-23, "Diagnosis Procedure"](#).

Is the inspection result normal?

YES >> GO TO 3.

NO >> Repair or replace the error-detected parts.

3. CHECK AWD LOCK INDICATOR LAMP SIGNAL

 **With CONSULT-III**

1. Start the engine.

CAUTION:

Stop the vehicle.

2. Change AWD lock switch to "LOCK" from "AUTO".

3. Check "4WD MODE MON" of CONSULT-III "DATA MONITOR" for "ALL MODE AWD/4WD".

Does the item on "DATA MONITOR" indicate "LOCK"?

YES >> GO TO 4.

NO >> Replace AWD control unit. Refer to [DLN-51, "Exploded View"](#).

4. CHECK COMBINATION METER POWER SUPPLY CIRCUIT

Perform the trouble diagnosis for combination meter power supply circuit. Refer to [MWI-44, "COMBINATION METER : Diagnosis Procedure"](#).

Is the inspection result normal?

YES >> INSPECTION END

NO >> Repair or replace the error-detected parts.

AWD CONTROL UNIT

< ECU DIAGNOSIS INFORMATION >

[TRANSFER: TY20A]

ECU DIAGNOSIS INFORMATION

AWD CONTROL UNIT

Reference Value

INFOID:000000006260374

VALUES ON THE DIAGNOSIS TOOL

Monitor item	Condition	Value/Status	
STOP LAMP SW	Brake pedal: Depressed	On	
	Brake pedal: Released	Off	
ENG SPEED SIG	Engine stopped (Engine speed: Less than 400 rpm)	Stop	
	Engine running (Engine speed: 400 rpm or more)	Run	
ETS ACTUATOR	Engine stopped (Ignition switch: ON)	Off	
	Engine running	On	
4WD WARN LAMP	AWD warning lamp: ON	On	
	AWD warning lamp: OFF	Off	
4WD MODE SW	Releasing AWD lock switch.	AUTO	
	AWD lock switch is hold pressed.	LOCK	
4WD MODE MON	AWD LOCK indicator lamp: OFF	AUTO	
	AWD LOCK indicator lamp: ON	Vehicle speed below 10 km/h (6 mph)	LOCK
		Vehicle speed above 10 km/h (6 mph)	AUTO
DIS-TIRE MONI	Vehicle running with normal size tire installed	0 – 4 mm	
	Vehicle running with improper size tire installed (Front/rear tire size difference, wear condition)	4 – 8 mm, 8 – mm	
P BRAKE SW	Parking brake operated	On	
	Parking brake not operated	Off	
BATTERY VOLT	Always	Battery voltage	
THRTL POS SEN	When depressing accelerator pedal (Value rises gradually in response to throttle position.)	0 – 100%	
ETS SOLENOID	Engine running • At idle speed	AWD LOCK indicator lamp: OFF	Approx. 0.000 A
		AWD LOCK indicator lamp: ON	Approx. 0.000 A
	Engine running • 3,000 rpm or more constant	AWD LOCK indicator lamp: OFF	Approx. 0.000 – 1.800 A*
		AWD LOCK indicator lamp: ON	Approx. 1.800 A
FR RH SENSOR	Vehicle stopped	0.00 km/h (0.00 mph)	
	Vehicle running CAUTION: Check air pressure of tire under standard condition.	Nearly matches the speed meter display (±10% or less)	
FR LH SENSOR	Vehicle stopped	0.00 km/h (0.00 mph)	
	Vehicle running CAUTION: Check air pressure of tire under standard condition.	Nearly matches the speed meter display (±10% or less)	
RR RH SENSOR	Vehicle stopped	0.00 km/h (0.00 mph)	
	Vehicle running CAUTION: Check air pressure of tire under standard condition.	Nearly matches the speed meter display (±10% or less)	

AWD CONTROL UNIT

< ECU DIAGNOSIS INFORMATION >

[TRANSFER: TY20A]

Monitor item	Condition	Value/Status
RR LH SENSOR	Vehicle stopped	0.00 km/h (0.00 mph)
	Vehicle running CAUTION: Check air pressure of tire under standard condition.	Nearly matches the speed meter display(±10%)

*: The values are changed by throttle opening and engine speed.

TERMINAL LAYOUT

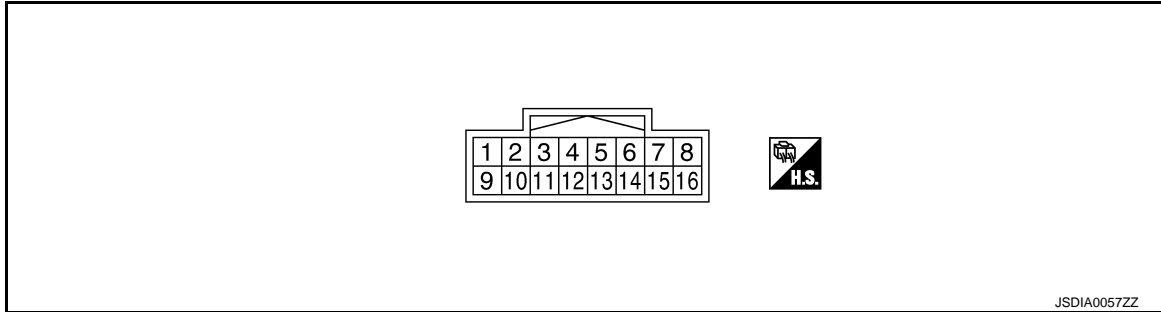

PHYSICAL VALUES

Terminal No. (Wire color)		Description		Condition	Value (Approx.)
+	-	Signal name	Input/ Output		
1 (LG)	Ground	AWD solenoid power supply	Output	Engine speed: At idle	AWD LOCK indicator lamp: OFF 0 V
					AWD LOCK indicator lamp: ON 0 V
				Engine speed: 3,000 rpm or more constant	AWD LOCK indicator lamp: OFF 2.5 V*
					AWD LOCK indicator lamp: ON 8 V
2 (L)	Ground	AWD solenoid ground	—	Engine speed: At idle	0 V
				Engine speed: 3,000 rpm or more constant	0 V
7 (R)	Ground	Ignition switch	Input	Ignition switch: ON	Battery voltage
				Ignition switch: OFF	0 V
8 (L)	—	CAN-H	Input/ Output	—	—
9 (G)	Ground	Power supply (AWD solenoid)	Input	Always	Battery voltage
10 (B)	Ground	Ground	—	Always	0 V
11 (B)	Ground	Ground	—	Always	0 V
14 (Y)	Ground	AWD lock switch	Output	Ignition switch: ON	Releasing AWD lock switch Battery voltage
					AWD lock switch is hold pressed. 0 V
16 (P)	—	CAN-L	Input/ Output	—	—

*: The values are changed by throttle opening and engine speed.

CAUTION:

When using circuit tester to measure voltage for inspection, be sure not to extend forcibly any connector terminals.

AWD CONTROL UNIT

< ECU DIAGNOSIS INFORMATION >

[TRANSFER: TY20A]

Wiring Diagram - AWD SYSTEM -

INFOID:000000006260375

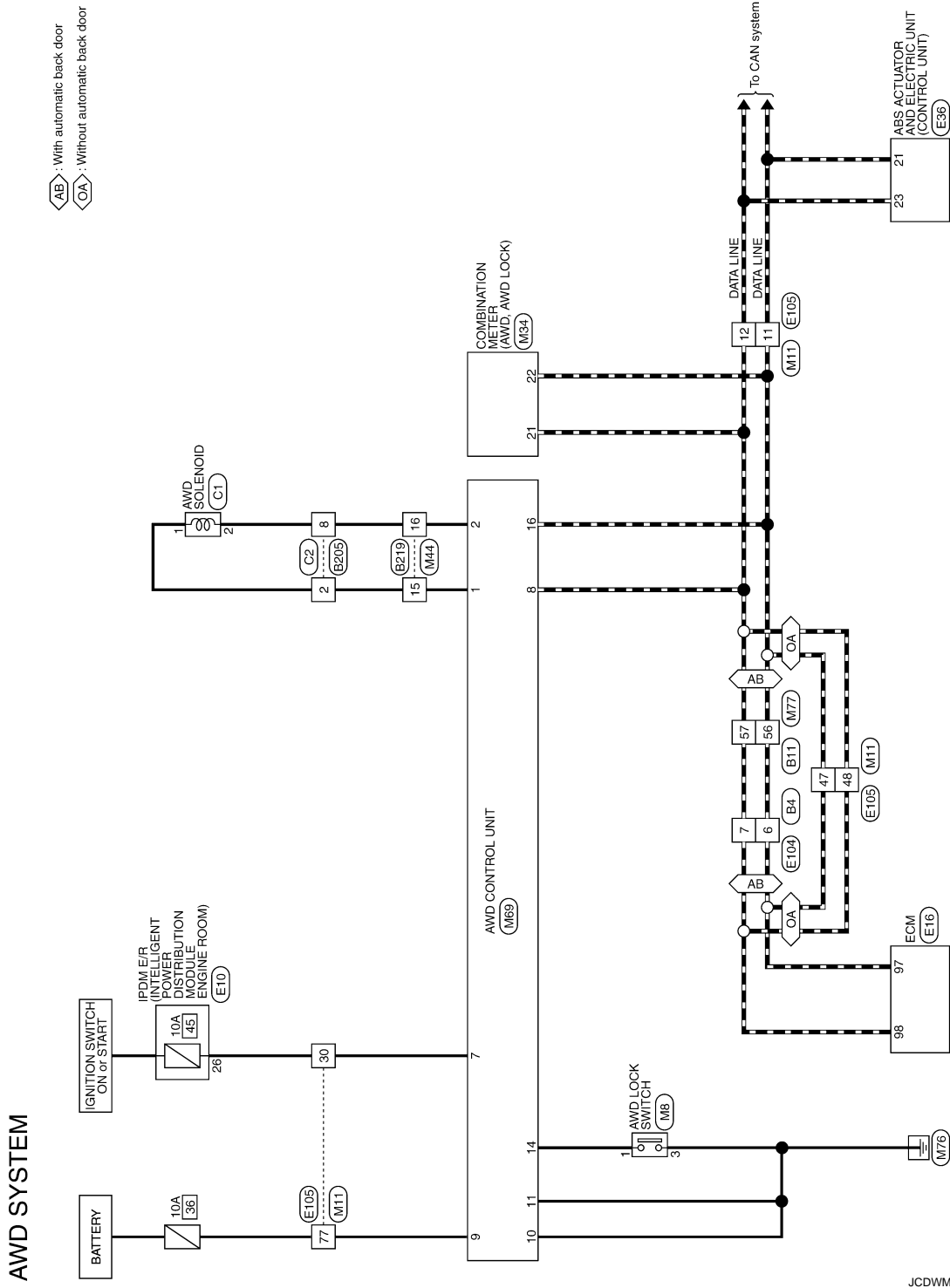

2008/09/23

JCDWM0487GB

AWD CONTROL UNIT

< ECU DIAGNOSIS INFORMATION >

[TRANSFER: TY20A]

AWD SYSTEM

Connector No.	B24
Connector Name	WIRE TO WIRE
Connector Type	THS2MW-ZS



1	2	3	4	5	6	7		
8	9	10	11	12	13	14	15	16

Terminal No.	Color of Wire	Signal Name [Specification]
1	SB	
2	W	
3	W	
4	R	
5	O	
6	P	
7	L	
8	B	
9	LG	
10	V	
11	L	
12	BR	
13	P	
14	BR	
15	O	
16	G	

Connector No.	B11
Connector Name	WIRE TO WIRE
Connector Type	THS2MW-ZS19



Terminal No.	Color of Wire	Signal Name [Specification]
1	SHIELD	
2	B	
3	R/L	
4	R/W	
5	SB	
6	P	

7	V	
8	SHIELD	
9	BR/L	
10	Y/G	
11	Y/L	
12	W/L	
13	L	
14	BR	
15	SB	
16	BR	
17	V	
18	SB	
19	R	
20	P	
21	LG	
22	W	
23	Y	
24	GR	
25	Y	
27	V	
28	W/L	
30	P	
31	O	
32	BR	
34	SB	
35	SHIELD	
36	L/O	
37	LG	
40	Y	
41	GR	
42	SB	
46	LG	
47	SB	
48	SHIELD	
48	B	
50	R/W	
51	R/L	
52	B	
53	Y	
54	LG	
55	BR	
56	P	
57	L	
58	R	
59	SHIELD	
60	B	
61	R/L	
62	R/W	
63	LG	
64	Y	
65	BR	
66	V	

67	GR	
68	R	
69	SHIELD	
70	W/R	
71	B/R	
72	Y	
73	LG	
74	SB	
75	L	
76	G	
77	R	
79	B	
80	W	
81	R	
82	L	
83	BR	
84	O	
85	G	
86	SB	
87	R	
88	G	
89	GR	
90	Y	
91	G	
92	BR	
93	G	
94	V	
95	BR	
96	GR	
97	R	
98	LG	
99	O	

Connector No.	B205
Connector Name	WIRE TO WIRE
Connector Type	RH1ZPB



6	5	4	3	2	1
12	11	10	9	8	7

Terminal No.	Color of Wire	Signal Name [Specification]
1	W	
2	SB	
3	V	
7	B	

8	Y	
9	P	

Connector No.	B219
Connector Name	WIRE TO WIRE
Connector Type	THS2MW-NH



1	2	3	4	5	6	7	8	9	10	11	12	13	14	15	16
17	18	19	20	21	22	23	24	25	26	27	28	29	30	31	32

Terminal No.	Color of Wire	Signal Name [Specification]
1	W/R	
2	B/R	
3	SHIELD	
4	W/R	
5	B/R	
6	SHIELD	
7	GR/V	
8	W/L	
9	SHIELD	
10	GR/V	
11	W/L	
12	SHIELD	
13	SB	
15	SB	
16	Y	
17	R	
18	W	
29	G	
30	P	
31	V	
32	BR	

A
B
C
DLN
E
F
G
H
I
J
K
L
M
N
O
P

AWD CONTROL UNIT

< ECU DIAGNOSIS INFORMATION >

[TRANSFER: TY20A]

AWD SYSTEM

Connector No.	C1
Connector Name	AWD SOLENOID
Connector Type	RS02FGY



Terminal No.	Color of Wire	Signal Name [Specification]
1	SB	-
2	L	-

Connector No.	C2
Connector Name	WIRE TO WIRE
Connector Type	RH12MB

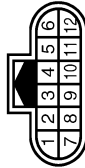

Terminal No.	Color of Wire	Signal Name [Specification]
1	L	-
2	SB	-
3	V	-
7	R	-
8	L	-
9	P	-

Connector No.	E10
Connector Name	IPW E/F INTELLIGENT POWER DISTRIBUTION MODULE (ENGINE ROOM)
Connector Type	TH20FW-CSI2-IM4-1V



Terminal No.	Color of Wire	Signal Name [Specification]
4	LG	-
5	Y	-
7	GR	-
10	BR	-
12	B	-
13	SB	-
15	W	-
16	R	-
19	Y	-
20	L	-
21	O	-
22	SB	-
23	GR	-
24	G	-
25	GR	-
26	Y	-
27	W	-
28	SB	-
30	BR	-
34	O	-
35	P	-
36	G	-
38	GR	-

Connector No.	E16
Connector Name	ECM
Connector Type	RH24FB-RZ8-L-LH

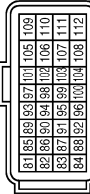

Terminal No.	Color of Wire	Signal Name [Specification]
81	W	ACCELERATOR PEDAL POSITION SENSOR 1
82	O	ACCELERATOR PEDAL POSITION SENSOR 2
83	BR	SENSOR POWER SUPPLY
84	B	SENSOR GROUND
85	Y	ASCD STEERING SWITCH
86	SB	EVAP CONTROL SYSTEM PRESSURE SENSOR
87	GR	SENSOR POWER SUPPLY
88	O	DATA LINK CONNECTOR
91	L	SENSOR POWER SUPPLY
92	BR	SENSOR GROUND
93	BR	IGNITION SWITCH

Terminal No.	Color of Wire	Signal Name [Specification]
94	GR	ENGINE SPEED OUTPUT SIGNAL
95	Y	FUEL TANK TEMPERATURE SENSOR
96	GR	SENSOR GROUND
97	P	CAN COMMUNICATION LINE(CAN-L)
98	L	CAN COMMUNICATION LINE(CAN-H)
100	G	SENSOR GROUND
102	R	PHP SIGNAL
104	SB	SENSOR GROUND
105	V	POWER SUPPLY FOR ECM
106	SB	STOP LAMP SWITCH
107	B	ECM GROUND
108	B	ECM GROUND
109	W	EVAP CANISTER VENT CONTROL VALVE
110	G	ASCD BRAKE SWITCH
111	B	ECM GROUND
112	B	ECM GROUND

Connector No.	E36
Connector Name	ABS ACTUATOR AND ELECTRIC UNIT (CONTROL UNIT)
Connector Type	AEZZ2FB-AJ24-LH

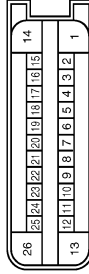

Terminal No.	Color of Wire	Signal Name [Specification]
1	R	VALVE / ECU SUPPLY
2	Y	WSS RL SIG (-)
3	L	WSS RL PWR (+)
4	GR	CLUSTER SUPPLY
5	B	WSS FR PWR (+)
6	W	WSS FR SIG (-)
7	LG	LIS
8	V	WSS FL SIG (-)
9	W	WSS FL PWR (+)
10	SB	CLUSTER GND
11	P	WSS RR PWR (+)
12	V	WSS RR SIG (-)
13	B/W	MOTOR GND
14	G	MOTOR SUPPLY
16	SB	BLS
19	BR	CAN 2 H
20	GR	IGN
21	P	CAN 1 L
22	Y	VDC OFF SW
23	L	CAN 1 H

25	W	CAN 2 L
26	B/W	VALVE / ECU GND

Connector No.	E104
Connector Name	WIRE TO WIRE
Connector Type	MS16FW-CS



Terminal No.	Color of Wire	Signal Name [Specification]
1	Y	-
2	SB	-
3	L	-
4	R	-
5	L	-
6	P	-
7	L	-
8	B/W	-
9	SB	-
10	GR	-
11	R	-
12	W	-
13	P	-
14	V	-
15	Y	-
16	L	-

AWD CONTROL UNIT

< ECU DIAGNOSIS INFORMATION >

[TRANSFER: TY20A]

AWD SYSTEM

Connector No.	E103
Connector Name	WIRE TO WIRE
Connector Type	TH70FW-ZS10-M3



Terminal No.	Color of Wire	Signal Name [Specification]
3	Y	
5	LG	
6	GR	
8	G	
11	P	
12	L	
13	Y	
14	O	
15	BR	
20	Y	
21	BR	
22	P	
24	L	
25	O	
28	SB	
29	W	
30	Y	
47	P	
48	L	
49	SB	
50	GR	
51	V	
53	GR	
54	BR	
55	Y	
56	W/L	
60	V	
61	BR	
82	O	
83	L/O	
64	SHIELD	
66	W	
67	BR	
68	Y	
69	SB	
70	GR	
71	SB	

72	Y	-
73	L	-
74	W	-
75	BR	-
76	GR	-
77	O	-
78	Y	- [With navigation system]
78	G	- [With iPod without navigation system]
78	V	- [Without iPod and navigation system]
79	Y	-
80	R	-
81	W	-
82	LG	-
83	O	-

Connector No.	M8
Connector Name	AWD LOCK SWITCH
Connector Type	TK08FW-1V



Terminal No.	Color of Wire	Signal Name [Specification]
1	Y	
2	SB	
3	B	
4	R	

Connector No.	M11
Connector Name	WIRE TO WIRE
Connector Type	TH70FW-CS10-M3



Terminal No.	Color of Wire	Signal Name [Specification]
3	P	
3	O	

6	G	-
8	R	-
11	P	-
12	L	-
13	V	-
14	Y	-
15	R	-
20	Y	-
21	BR	-
22	G	-
24	Y	-
25	L	-
28	BR	-
29	L	-
30	R	-
47	P	-
48	L	-
49	W	-
50	GR	-
51	LG	-
52	Y	-
53	V	-
54	SB	-
55	P	-
56	SB	-
60	V	-
61	GR	-
62	O	-
63	V	-
64	SHIELD	-
66	W	-
67	R	-
68	W	-
69	P	-
70	G	-
71	G	-
72	BR	-
73	L	-
74	W	-
75	BR	-
76	R	-
77	G	-
78	Y	-
79	G	-
80	R	-
81	W	-
82	W	-
83	O	-

Connector No.	M34
Connector Name	COMBINATION METER
Connector Type	TH08FW-1H

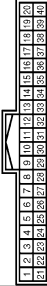

Terminal No.	Color of Wire	Signal Name [Specification]
1	Y	BAT
2	O	IGN
3	B	GROUND
4	B	GROUND
5	SB	ILLUMINATION CONTROL
8	SB	TRIP-RESET SWITCH
9	W	SW-ILL POWER
10	O	METER CONTROL SW GND
11	L	ENTER SWITCH
12	R	SELECT SWITCH
13	V	ILLUMINATION CONTROL SWITCH (+) [With automatic drive position]
13	Y	ILLUMINATION CONTROL SWITCH (+) [Without automatic drive position]
14	GR	ILLUMINATION CONTROL SWITCH (-)
15	BR	AIR BAG
18	L	AMBIENT SENSOR
19	P	AMBIENT SENSOR POWER
20	L	AMBIENT SENSOR GROUND
21	Y	CAN-H
22	P	CAN-L
23	B	GROUND
24	W	FUEL LEVEL SENSOR GROUND
25	BR	CHG
26	G	PARKING BRAKE SWITCH
27	V	BRAKE FLUID LEVEL SWITCH
29	R	WASHER LEVEL SWITCH
30	P	VEHICLE SPEED (2-PULSE)
31	V	VEHICLE SPEED (8-PULSE)
32	LG	OD OFF / SPORTS
34	G	FUEL LEVEL SENSOR
35	SB	SEAT BELT BUCKLE SWITCH (DRIVER SIDE)
36	R	SEAT BELT BUCKLE SWITCH (PASSENGER SIDE)

A
B
C
DLN
E
F
G
H
I
J
K
L
M
N
O
P

AWD CONTROL UNIT

< ECU DIAGNOSIS INFORMATION >

[TRANSFER: TY20A]

89	B	-
90	O	-
91	G	-
92	BR	-
93	P	-
94	V	-
95	O	-
96	SB	-
97	L	-
98	LG	-
99	Y	-

31	W	-
32	BR	-
34	Y	-
35	SHIELD	-
36	G	-
37	Y	-
40	O	-
41	LG	-
42	SB	-
46	LG	-
47	SB	-
48	SHIELD	-
49	R	-
50	LG	-
51	V	-
52	B	-
53	BR	-
54	B	-
55	G	-
56	P	-
57	L	-
58	SB	-
59	SHIELD	-
60	B	-
61	R	-
62	W	-
63	O	-
64	Y	-
65	V	-
66	V	-
67	GR	-
68	G	-
69	SHIELD	-
70	L	-
71	R	-
72	LG	-
73	Y	-
74	P	-
75	P	-
76	L	-
77	BR	-
79	B	-
80	W	-
81	LG	-
82	L	-
83	W	-
83	GR	- [With automatic drive positioner]
84	R	-
85	V	-
86	W	-
87	R	-
88	G	-

2	L	AWD SOL-
7	R	IGN
8	L	CAN-H
9	G	SOL BATT
10	B	GND
11	B	GND
14	Y	LOCK SW
16	P	CAN-L

Connector No.	M77
Connector Name	WIRE TO WIRE
Connector Type	TH60FW-C519

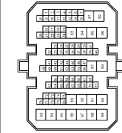

Terminal No.	Color of Wire	Signal Name [Specification]
1	SHIELD	-
2	B	-
3	W	-
4	R	-
5	Y	-
6	W	-
7	G	-
8	SHIELD	-
9	W	-
10	R	-
11	G	-
12	B	-
13	O	-
14	R	-
15	SB	-
16	R	-
17	V	-
18	P	-
19	P	-
20	LG	-
21	Y	-
22	O	-
23	LG	-
24	SB	-
25	Y	-
27	Y	-
28	R	-
30	Y	-

AWD SYSTEM

Connector No.	M44
Connector Name	WIRE TO WIRE
Connector Type	TH32FW-NH

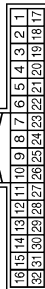

Terminal No.	Color of Wire	Signal Name [Specification]
1	G	-
2	R	-
3	SHIELD	-
4	B	-
5	W	-
6	SHIELD	-
7	L	-
8	R	-
9	SHIELD	-
10	V	-
11	LG	-
12	SHIELD	-
13	P	-
15	LG	-
16	L	-
17	R	-
18	W	-
29	LG	-
30	O	-
31	Y	-
32	V	-

Connector No.	M69
Connector Name	AWD CONTROL UNIT
Connector Type	TH16FW-NH

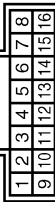

Terminal No.	Color of Wire	Signal Name [Specification]
1	LG	AWD SOL+

Fail-Safe

AWD system

- If any malfunction occurs in AWD electrical system, and control unit detects the malfunction, AWD warning lamp on combination meter turns ON to indicate system malfunction.
- When AWD warning lamp is ON, vehicle changes to front-wheel drive or shifts to 4-wheel drive (rear-wheels still have some driving torque).

JCDWM1233GB

INFOID:000000006260376

AWD CONTROL UNIT

< ECU DIAGNOSIS INFORMATION >

[TRANSFER: TY20A]

- AWD system activates its protection function (shuts down AWD system temporarily) if AWD system detects high load continuously or the front wheel tire size differs from the rear tire size. (AWD system is automatically restored if AWD system no longer detects any overload or the tire size difference is eliminated.)

Mode	Warning lamp	DTC	Detected area (Error area)	Error area and root cause
Protection function	Blinking *1	—	AWD control unit	Transfer assembly in protection mode. It is not malfunction. (Internal temperature rise of electronic controlled coupling)
	Blinking *2	—	AWD control unit	Malfunction in each tire or different tire diameter
Fail-safe	ON	C1201	AWD control unit	Internal malfunction of AWD control unit
		C1203	ABS actuator and electric unit (control unit)	ABS malfunction <ul style="list-style-type: none"> • Vehicle speed signal error
		C1204	AWD solenoid	<ul style="list-style-type: none"> • Internal malfunction of electronic controlled coupling • Malfunction of AWD solenoid power supply circuit (open or short) • Malfunction of AWD solenoid command current
		C1205	AWD control unit	Internal malfunction of AWD control unit
		C1210	ECM	Malfunction of engine control system
		U1000	CAN communication line	<ul style="list-style-type: none"> • CAN communication error • Malfunction of AWD control unit
		U1010	AWD control unit	Malfunction of AWD control unit

*1: Quick blinking: 2 times/second (blinking for approximately 1 minute and then turned OFF)

*2: Slow blinking: 1 time/2 seconds (continuing to blink until ignition switch is turned OFF)

DTC Inspection Priority Chart

INFOID:000000006260377

If some DTCs are displayed at the same time, perform inspections one by one based on the following priority chart.

Priority	Detected items (DTC)
1	<ul style="list-style-type: none"> • U1000 CAN COMM CIRCUIT • U1010 CONTROL UNIT (CAN)
2	<ul style="list-style-type: none"> • C1201 CONTROLLER FAILURE • C1205 4WD ACTUATOR RLY
3	<ul style="list-style-type: none"> • C1204 4WD SOLENOID
4	<ul style="list-style-type: none"> • C1203 ABS SYSTEM • C1210 ENGINE SIGNAL 1

DTC Index

INFOID:000000006260378

DTC	Display Item	Reference
C1201	CONTROLLER FAILURE	DLN-12, "DTC Logic"
C1203	ABS SYSTEM	DLN-13, "DTC Logic"
C1204	4WD SOLENOID	DLN-14, "DTC Logic"
C1205	4WD ACTUATOR RLY	DLN-16, "DTC Logic"
C1210	ENGINE SIGNAL 1	DLN-18, "DTC Logic"
U1000	CAN COMM CIRCUIT	DLN-19, "DTC Logic"
U1010	CONTROL UNIT (CAN)	DLN-20, "DTC Logic"

AWD WARNING LAMP DOES NOT TURN ON

< SYMPTOM DIAGNOSIS >

[TRANSFER: TY20A]

SYMPTOM DIAGNOSIS

AWD WARNING LAMP DOES NOT TURN ON

Description

INFOID:000000006260379

AWD warning lamp does not turn ON when the ignition switch is turned to ON.

Diagnosis Procedure

INFOID:000000006260380

1. CHECK AWD WARNING LAMP

Perform the trouble diagnosis for AWD warning lamp. Refer to [DLN-25. "Diagnosis Procedure"](#).

Is the inspection result normal?

- YES >> Check each harness connector pin terminal for malfunction or disconnection.
- NO >> Repair or replace the error-detected parts.

AWD WARNING LAMP DOES NOT TURN OFF

< SYMPTOM DIAGNOSIS >

[TRANSFER: TY20A]

AWD WARNING LAMP DOES NOT TURN OFF

Description

INFOID:000000006260381

AWD warning lamp does not turn OFF several seconds after the engine started.

Diagnosis Procedure

INFOID:000000006260382

1.PERFORM SELF-DIAGNOSIS

With CONSULT-III

Perform self-diagnosis for "ALL MODE AWD/4WD".

Is any DTC detected?

YES >> Check the DTC.

NO >> GO TO 2.

2.CHECK AWD WARNING LAMP

Perform the trouble diagnosis of the AWD warning lamp. Refer to [DLN-25, "Diagnosis Procedure"](#).

Is the inspection result normal?

YES >> GO TO 3.

NO >> Repair or replace the error-detected parts.

3.CHECK AWD CONTROL UNIT POWER SUPPLY AND GROUND CIRCUIT

Perform the trouble diagnosis of the power supply and ground circuit. Refer to [DLN-21, "Diagnosis Procedure"](#).

Is the inspection result normal?

YES >> Check each harness connector pin terminal for malfunction or disconnection.

NO >> Repair or replace the error-detected parts.

A
B
C
DLN
E
F
G
H
I
J
K
L
M
N
O
P

HEAVY TIGHT-CORNER BRAKING SYMPTOM OCCURS

< SYMPTOM DIAGNOSIS >

[TRANSFER: TY20A]

HEAVY TIGHT-CORNER BRAKING SYMPTOM OCCURS

Description

INFOID:000000006260383

Heavy tight-corner braking symptom occurs when the vehicle is driven and the steering wheel is turned fully to either side after the engine is started.

NOTE:

Light tight-corner braking symptom may occur depending on driving conditions. This is not malfunction.

Diagnosis Procedure

INFOID:000000006260384

1. PERFORM ECM SELF-DIAGNOSIS

With CONSULT-III

Perform self-diagnosis for "ENGINE".

Is any DTC detected?

- YES >> Check the DTC.
- NO >> GO TO 2.

2. PERFORM SELF-DIAGNOSIS

With CONSULT-III

Perform self-diagnosis for "ALL MODE AWD/4WD".

Is DTC "U1000" detected?

- YES >> Proceed to [LAN-15, "Trouble Diagnosis Flow Chart"](#).
- NO >> GO TO 3.

3. CHECK AWD SOLENOID

Perform the trouble diagnosis of the AWD solenoid. Refer to [DLN-14, "Diagnosis Procedure"](#).

Is the inspection result normal?

- YES >> GO TO 4.
- NO >> Repair or replace the error-detected parts.

4. CHECK ELECTRIC CONTROLLED COUPLING

1. Turn the ignition switch OFF.
2. Set the transaxle to neutral. Release the parking brake.
3. Lift up the vehicle.
4. Rotate the propeller shaft by hand.
5. Hold rear wheel of right and left lightly.

Does rear wheel rotate?

- YES >> Replace electric controlled coupling for mechanical malfunction (clutch sticking etc.). Refer to [DLN-96, "Exploded View"](#).
- NO >> Check each harness connector pin terminal for disconnection.

VEHICLE DOES NOT ENTER AWD MODE

< SYMPTOM DIAGNOSIS >

[TRANSFER: TY20A]

VEHICLE DOES NOT ENTER AWD MODE

Description

INFOID:000000006260385

Vehicle does not enter 4-wheel drive mode even though AWD warning lamp turned to OFF.

Diagnosis Procedure

INFOID:000000006260386

1. CHECK AWD WARNING LAMP

Turn the ignition switch ON.

Does AWD warning lamp turn ON?

YES >> GO TO 2.

NO >> Proceed to diagnosis procedure. Refer to [DLN-25, "Diagnosis Procedure"](#).

2. CHECK PARKING BRAKE SWITCH SIGNAL

 With CONSULT-III

Check "P BRAKE SW" of CONSULT-III "DATA MONITOR" for "ALL MODE AWD/4WD".

Monitor Item	Condition	Status
P BRAKE SW	When the parking brake pedal is operation.	ON
	When the parking brake pedal is not operation.	OFF

Is the inspection result normal?

YES >> GO TO 3.

NO >> Proceed to diagnosis procedure. Refer to [BRC-88, "Diagnosis Procedure"](#).

3. CRUISE TEST

Drive the vehicle for a period of time.

Does any symptom occur?

YES >> Replace electric controlled coupling for mechanical malfunction (mechanical engagement of clutch is not possible). Refer to [DLN-96, "Exploded View"](#).

NO >> Check each harness connector pin terminal for disconnection.

A
B
C
DLN
E
F
G
H
I
J
K
L
M
N
O
P

AWD WARNING LAMP BLINKS QUICKLY

< SYMPTOM DIAGNOSIS >

[TRANSFER: TY20A]

AWD WARNING LAMP BLINKS QUICKLY

Description

INFOID:000000006260387

While driving, AWD warning lamp blinks 2 times in 1 second and it turns OFF after 1 minute.

- This symptom protects drivetrain parts when a heavy load is applied to the electric controlled coupling and multiple disc clutch temperature increases. Also, optional distribution of torque sometimes becomes rigid before lamp blinks quickly. Both cases are not malfunction.
- When this symptom occurs, stop vehicle and allow it to idle for some times. Blinking will stop and system will be restored.

AWD WARNING LAMP BLINKS SLOWLY

< SYMPTOM DIAGNOSIS >

[TRANSFER: TY20A]

AWD WARNING LAMP BLINKS SLOWLY

Description

INFOID:000000006260388

AWD warning lamp blinks at approximately 2 seconds intervals while driving.

Diagnosis Procedure

INFOID:000000006260389

1.CHECK TIRE

Check the following.

- Tire pressure
- Wear condition
- Front and rear tire size (There is no difference between front and rear tires.)

Is the inspection result normal?

YES >> GO TO 2.

NO >> Repair or replace error-detected parts. And then, drive the vehicle at speed of 20 km/h (12 MPH) or more for 5 seconds or more. Improper size information is initialized accordingly.

2.CHECK INPUT SIGNAL OF TIRE DIAMETER

 **With CONSULT-III**

1. Start the engine.
2. Drive at 20 km/h (12 MPH) or more for approximately 4 minutes.
3. Check "DIS-TIRE MONI" of CONSULT-III "DATA MONITOR" for "ALL MODE AWD/4WD".

Does the item on "DATA MONITOR" indicate "0 - 4 mm"?

YES >> INSPECTION END

NO >> GO TO 3.

3.TERMINAL INSPECTION

Check AWD control unit harness connector for disconnection.

Is the inspection result normal?

YES >> Replace AWD control unit. Refer to [DLN-51. "Exploded View"](#).

NO >> Repair or replace the error-detected parts.

A
B
C
DLN
E
F
G
H
I
J
K
L
M
N
O
P

NOISE, VIBRATION AND HARSHNESS (NVH) TROUBLESHOOTING

< SYMPTOM DIAGNOSIS >

[TRANSFER: TY20A]

NOISE, VIBRATION AND HARSHNESS (NVH) TROUBLESHOOTING

NVH Troubleshooting Chart

INFOID:000000006260390

Use the chart below to find the cause of the symptom. The numbers indicate the order of the inspection. If necessary, repair or replace these parts.

Reference		DLN-49. "Inspection"			DLN-55. "Exploded View"	DLN-55. "Exploded View"	DLN-55. "Exploded View"	DLN-62. "Inspection After Disassembly"	DLN-62. "Inspection After Disassembly"
SUSPECTED PARTS (Possible cause)		TRANSFER OIL (Level low)	TRANSFER OIL (Wrong)	TRANSFER OIL (Level too high)	LIQUID GASKET (Damaged)	O-RING (Worn or damaged)	OIL SEAL (Worn or damaged)	GEAR (Worn or damaged)	BEARING (Worn or damaged)
Symptom	Noise	1	2				3	3	3
	Transfer oil leakage		3	1	2	2	2		

PRECAUTION

PRECAUTIONS
FOR USA AND CANADA

FOR USA AND CANADA : Precaution for Supplemental Restraint System (SRS) "AIR BAG" and "SEAT BELT PRE-TENSIONER"

INFOID:000000006260391

The Supplemental Restraint System such as "AIR BAG" and "SEAT BELT PRE-TENSIONER", used along with a front seat belt, helps to reduce the risk or severity of injury to the driver and front passenger for certain types of collision. This system includes seat belt switch inputs and dual stage front air bag modules. The SRS system uses the seat belt switches to determine the front air bag deployment, and may only deploy one front air bag, depending on the severity of a collision and whether the front occupants are belted or unbelted. Information necessary to service the system safely is included in the "SRS AIR BAG" and "SEAT BELT" of this Service Manual.

WARNING:

Always observe the following items for preventing accidental activation.

- To avoid rendering the SRS inoperative, which could increase the risk of personal injury or death in the event of a collision that would result in air bag inflation, all maintenance must be performed by an authorized NISSAN/INFINITI dealer.
- Improper maintenance, including incorrect removal and installation of the SRS, can lead to personal injury caused by unintentional activation of the system. For removal of Spiral Cable and Air Bag Module, see "SRS AIR BAG".
- Never use electrical test equipment on any circuit related to the SRS unless instructed to in this Service Manual. SRS wiring harnesses can be identified by yellow and/or orange harnesses or harness connectors.

PRECAUTIONS WHEN USING POWER TOOLS (AIR OR ELECTRIC) AND HAMMERS

WARNING:

Always observe the following items for preventing accidental activation.

- When working near the Air Bag Diagnosis Sensor Unit or other Air Bag System sensors with the ignition ON or engine running, never use air or electric power tools or strike near the sensor(s) with a hammer. Heavy vibration could activate the sensor(s) and deploy the air bag(s), possibly causing serious injury.
- When using air or electric power tools or hammers, always switch the ignition OFF, disconnect the battery, and wait at least 3 minutes before performing any service.

FOR USA AND CANADA : Precaution for Procedure without Cowl Top Cover

INFOID:000000006260392

When performing the procedure after removing cowl top cover, cover the lower end of windshield with urethane, etc to prevent damage to windshield.

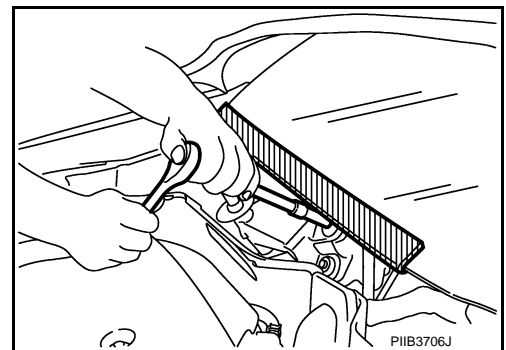

FOR USA AND CANADA : Service Notice or Precautions for Transfer

INFOID:000000006260393

- After overhaul refill the transfer with new transfer oil.
- Check the oil level or replace the oil only with the vehicle parked on level surface.
- During removal or installation, keep inside of transfer clear of dust or dirt.
- Replace all tires at the same time. Always use tires of the proper size and the same brand and pattern. Fitting improper size and unusual wear tires applies excessive force to vehicle mechanism and can cause longitudinal vibration.
- Disassembly should be done in a clean work area.

A
B
C
DLN
E
F
G
H
I
J
K
L
M
N
O
P

PRECAUTIONS

< PRECAUTION >

[TRANSFER: TY20A]

- Before proceeding with disassembly, thoroughly clean the transfer. It is important to prevent the internal parts from becoming contaminated by dirt or other foreign matter.
- Check for the correct installation status prior to removal or disassembly. If matching marks are required, be certain they do not interfere with the function of the parts when applied.
- All parts should be carefully cleaned with a general purpose, non-flammable solvent before inspection or reassembly.
- Check appearance of the disassembled parts for damage, deformation, and unusual wear. Replace them with a new one if necessary.
- Gaskets, seals, O-rings and lock nuts should be replaced any time when the transfer is disassembled.
- In principle, tighten bolts or nuts gradually in several steps working diagonally from inside to outside. If tightening sequence is specified, use it.
- Observe the specified torque when assembling.
- Clean and flush the parts sufficiently and blow-dry them.
- Be careful not to damage sliding surfaces and mating surfaces.
- Use lint-free cloth or towels for wiping parts clean. Common shop rags can leave fibers that could interfere with the operation of the transfer.

FOR MEXICO

FOR MEXICO : Precaution for Supplemental Restraint System (SRS) "AIR BAG" and "SEAT BELT PRE-TENSIONER"

INFOID:000000006260394

The Supplemental Restraint System such as "AIR BAG" and "SEAT BELT PRE-TENSIONER", used along with a front seat belt, helps to reduce the risk or severity of injury to the driver and front passenger for certain types of collision. Information necessary to service the system safely is included in the "SRS AIR BAG" and "SEAT BELT" of this Service Manual.

WARNING:

Always observe the following items for preventing accidental activation.

- **To avoid rendering the SRS inoperative, which could increase the risk of personal injury or death in the event of a collision that would result in air bag inflation, all maintenance must be performed by an authorized NISSAN/INFINITI dealer.**
- **Improper maintenance, including incorrect removal and installation of the SRS, can lead to personal injury caused by unintentional activation of the system. For removal of Spiral Cable and Air Bag Module, see "SRS AIR BAG".**
- **Never use electrical test equipment on any circuit related to the SRS unless instructed to in this Service Manual. SRS wiring harnesses can be identified by yellow and/or orange harnesses or harness connectors.**

PRECAUTIONS WHEN USING POWER TOOLS (AIR OR ELECTRIC) AND HAMMERS

WARNING:

Always observe the following items for preventing accidental activation.

- **When working near the Air Bag Diagnosis Sensor Unit or other Air Bag System sensors with the ignition ON or engine running, never use air or electric power tools or strike near the sensor(s) with a hammer. Heavy vibration could activate the sensor(s) and deploy the air bag(s), possibly causing serious injury.**
- **When using air or electric power tools or hammers, always switch the ignition OFF, disconnect the battery, and wait at least 3 minutes before performing any service.**

FOR MEXICO : Precaution for Procedure without Cowl Top Cover

INFOID:000000006260395

When performing the procedure after removing cowl top cover, cover the lower end of windshield with urethane, etc to prevent damage to windshield.

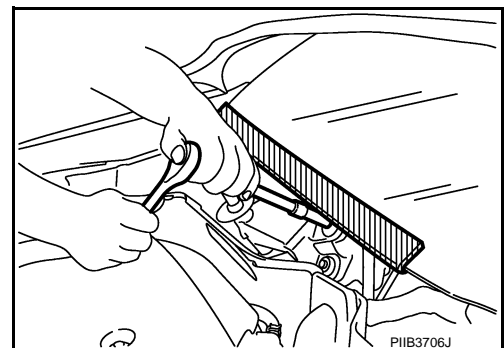

PRECAUTIONS

< PRECAUTION >

[TRANSFER: TY20A]

FOR MEXICO : Service Notice or Precautions for Transfer

INFOID:000000006260396

- After overhaul refill the transfer with new transfer oil.
- Check the oil level or replace the oil only with the vehicle parked on level surface.
- During removal or installation, keep inside of transfer clear of dust or dirt.
- Replace all tires at the same time. Always use tires of the proper size and the same brand and pattern. Fitting improper size and unusual wear tires applies excessive force to vehicle mechanism and can cause longitudinal vibration.
- Disassembly should be done in a clean work area.
- Before proceeding with disassembly, thoroughly clean the transfer. It is important to prevent the internal parts from becoming contaminated by dirt or other foreign matter.
- Check for the correct installation status prior to removal or disassembly. If matching marks are required, be certain they do not interfere with the function of the parts when applied.
- All parts should be carefully cleaned with a general purpose, non-flammable solvent before inspection or reassembly.
- Check appearance of the disassembled parts for damage, deformation, and unusual wear. Replace them with a new one if necessary.
- Gaskets, seals, O-rings and lock nuts should be replaced any time when the transfer is disassembled.
- In principle, tighten bolts or nuts gradually in several steps working diagonally from inside to outside. If tightening sequence is specified, use it.
- Observe the specified torque when assembling.
- Clean and flush the parts sufficiently and blow-dry them.
- Be careful not to damage sliding surfaces and mating surfaces.
- Use lint-free cloth or towels for wiping parts clean. Common shop rags can leave fibers that could interfere with the operation of the transfer.

A

B

C

DLN

E

F

G

H

I

J

K

L

M

N

O

P

PREPARATION

< PREPARATION >

[TRANSFER: TY20A]

PREPARATION

PREPARATION

Special Service Tool

INFOID:000000006260397

The actual shapes of Kent-Moore tools may differ from those of special service tools illustrated here.

Tool number (Kent-Moore No.) Tool name	Description
KV38101700 (—) Drift a: 82 mm (3.23 in) dia. b: 78 mm (3.07 in) dia.	Installing side oil seal (installing adapter case oil seal)
ST33200000 (J-26082) Drift a: 60 mm (2.36 in) dia. b: 44.5 mm (1.752 in) dia.	<ul style="list-style-type: none"> Removing gear ring bearing inner race (adapter case side) Installing companion flange
ST33220000 (J-25804-01) Drift a: 37 mm (1.46 in) dia. b: 31 mm (1.22 in) dia. c: 22 mm (0.87 in) dia.	Removing drive pinion
ST33061000 (J-8107-2) Drift a: 38 mm (1.50 in) dia. b: 28.5 mm (1.122 in) dia.	Removing gear ring bearing inner race (transfer case side)
KV381054S0 (J-34286) Puller	<ul style="list-style-type: none"> Removing pinion rear bearing outer race Removing pinion front bearing outer race Removing gear ring oil seal
ST33230000 (J-25805-01) Drift a: 51 mm (2.01 in) dia. b: 41 mm (1.61 in) dia. c: 28.5 mm (1.122 in) dia.	Installing gear ring oil seal

PREPARATION

< PREPARATION >

[TRANSFER: TY20A]

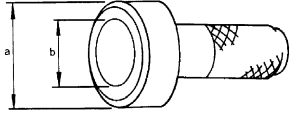
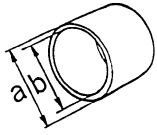
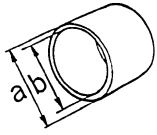
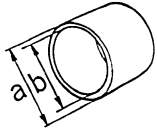
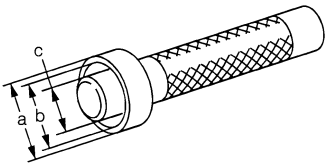
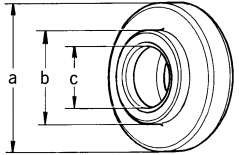
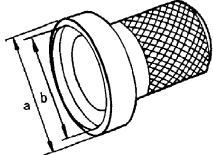
Tool number (Kent-Moore No.) Tool name	Description	
ST30720000 (J-25405) Drift a: 77 mm (3.03 in) dia. b: 55.5 mm (2.185 in) dia. <div style="text-align: center;">  <p>ZZA0811D</p> </div>	<ul style="list-style-type: none"> • Installing gear ring bearing outer race (transfer case side) • Installing gear ring bearing inner race (transfer case side) • Installing gear ring bearing inner race (adapter case side) • Installing gear ring bearing outer race (adapter case side) • Installing transfer case oil seal 	A B C DLN
ST27863000 (—) Drift a: 74.5 mm (2.933 in) dia. b: 62.5 mm (2.461 in) dia. <div style="text-align: center;">  <p>ZZA1003D</p> </div>	Installing gear ring bearing inner race (transfer case side)	E F
KV40101630 (J-35870) Drift a: 68 mm (2.68 in) dia. b: 60 mm (2.36 in) dia. <div style="text-align: center;">  <p>ZZA1003D</p> </div>	Installing gear ring bearing inner race (transfer case side)	G H
KV38102510 (—) Drift a: 71 mm (2.80 in) dia. b: 65 mm (2.56 in) dia. <div style="text-align: center;">  <p>ZZA1003D</p> </div>	Installing gear ring bearing inner race (adapter case side)	I J K
KV38100300 (J-25523) Drift a: 54 mm (2.13 in) dia. b: 46 mm (1.81 in) dia. c: 32 mm (1.26 in) dia. <div style="text-align: center;">  <p>ZZA1046D</p> </div>	Installing pinion rear bearing outer race	L M
ST30901000 (J-26010-01) Drift a: 79 mm (3.11 in) dia. b: 45 mm (1.77 in) dia. c: 35.2 mm (1.386 in) dia. <div style="text-align: center;">  <p>ZZA0978D</p> </div>	<ul style="list-style-type: none"> • Installing pinion front bearing outer race • Installing pinion front bearing inner race 	N O
ST33400001 (J-26082) Drift a: 60 mm (2.36 in) dia. b: 47 mm (1.85 in) dia. <div style="text-align: center;">  <p>ZZA0814D</p> </div>	<ul style="list-style-type: none"> • Installing pinion front bearing outer race • Installing pinion sleeve oil seal 	P

PREPARATION

< PREPARATION >

[TRANSFER: TY20A]

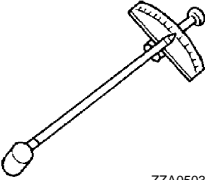
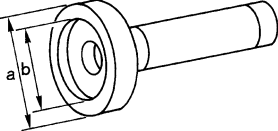
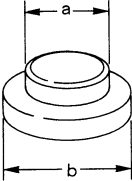
Tool number (Kent-Moore No.) Tool name	Description
ST3127S000 (J-25765-A) Preload gauge  ZZA0503D	Measuring preload torque
KV38100200 (—) Drift a: 65 mm (2.56 in) dia. b: 49 mm (1.93 in) dia.  ZZA1143D	Removing transfer case oil seal
KV40101840 (—) Drift a: 77 mm (3.03 in) dia. b: 85 mm (3.35 in) dia.  ZZA0881D	Installing gear ring bearing outer race (transfer case side)

Commercial Service Tool

INFOID:000000006260398

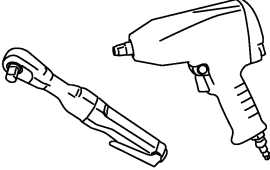
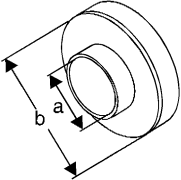
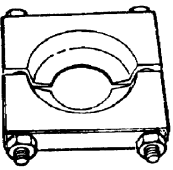
Tool name	Description
Power tool  PBIC0190E	Loosening nuts and bolts and nuts
Drift a: 89 mm (3.50 in) dia. b: 72 mm (2.83 in) dia.  NT660	Installing gear ring bearing outer race (adapter case side)
Replacer  ZZA0700D	Removing pinion front bearing inner race

PERIODIC MAINTENANCE

TRANSFER OIL

Inspection

INFOID:000000006260399

OIL LEAKAGE

Check transfer surrounding area (oil seal, drain plug, filler plug, and transfer case, etc.) for oil leakage.

OIL LEVEL

1. Remove filler plug (1) and gasket. Then check that oil is filled up (A) from mounting hole for the filler plug.
2. Before installing filler plug, set a new gasket. Install filler plug on transfer and tighten to the specified torque. Refer to [DLN-55, "Exploded View"](#).

↶ : Vehicle front

CAUTION:
Never reuse gaskets.

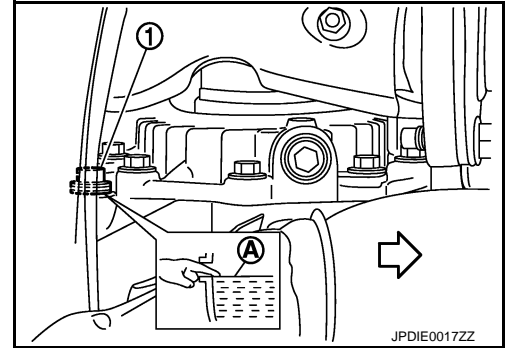

JPDIE0017ZZ

INFOID:000000006260400

Draining

1. Run the vehicle to warm up the transfer unit sufficiently.
2. Stop the engine and remove drain plug (1) and gaskets to drain the transfer oil.
3. Before installing drain plug, set a new gasket. Install drain plug on transfer and tighten to the specified torque. Refer to [DLN-55, "Exploded View"](#).

↶ : Vehicle front

CAUTION:
Never reuse gaskets.

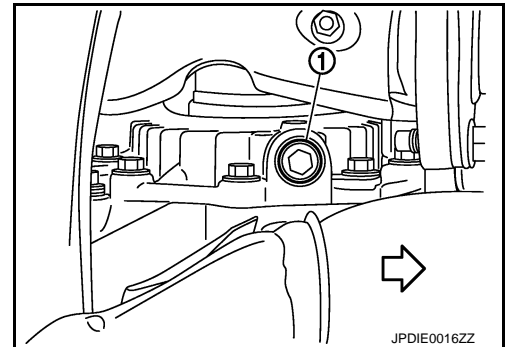

JPDIE0016ZZ

INFOID:000000006260401

Refilling

1. Remove filler plug (1) and gasket. Then fill oil up to mounting hole (A) for the filler plug.

↶ : Vehicle front

Oil grade and viscosity

: Refer to [MA-15, "FOR NORTH AMERICA : Fluids and Lubricants"](#) (for NORTH AMERICA), [MA-16, "FOR MEXICO : Fluids and Lubricants"](#) (for MEXICO).

Oil capacity

: Refer to [DLN-78, "General Specifications"](#).

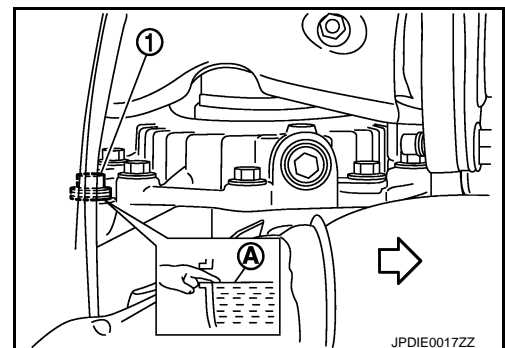

JPDIE0017ZZ

CAUTION:
Carefully fill the oil. (Fill up for approximately 3 minutes.)

2. Leave the vehicle for 3 minutes. Then check oil level again.
3. Before installing filler plug, set a new gasket. Install filler plug on transfer and tighten to the specified torque. Refer to [DLN-55, "Exploded View"](#).

A
B
C
DLN
E
F
G
H
I
J
K
L
M
N
O
P

TRANSFER OIL

< PERIODIC MAINTENANCE >

[TRANSFER: TY20A]

CAUTION:
Never reuse gasket.

REMOVAL AND INSTALLATION

AWD CONTROL UNIT

Exploded View

INFOID:000000006260402

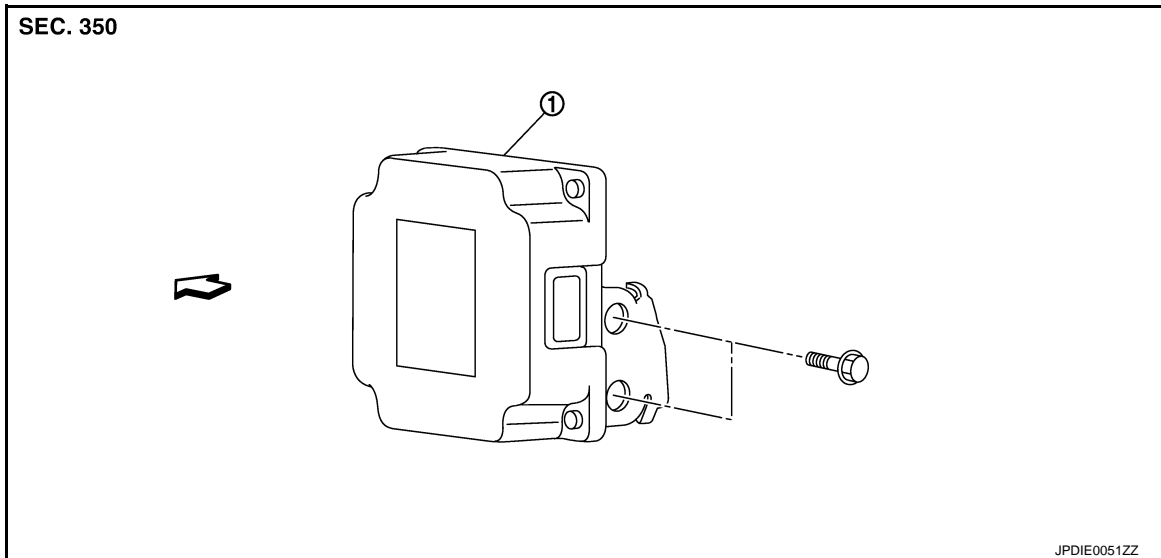

1. AWD control unit

← Vehicle front

Removal and Installation

INFOID:000000006260403

REMOVAL

1. Remove instrument lower panel LH. Refer to [IP-12, "Exploded View"](#).
2. Remove Knee protector (1).

← : Bolt

3. Disconnect AWD control unit harness connector.
4. Remove AWD control unit mounting bolts.

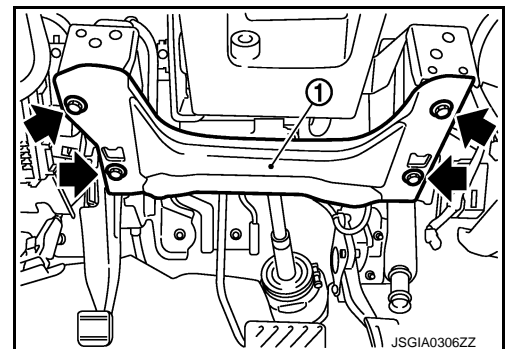

5. Remove AWD control unit (1).

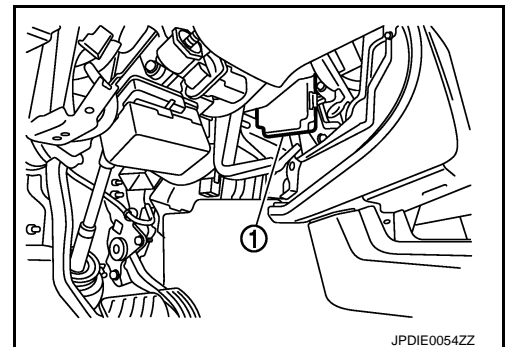

INSTALLATION

A
B
C
DLN
E
F
G
H
I
J
K
L
M
N
O
P

AWD CONTROL UNIT

< REMOVAL AND INSTALLATION >

[TRANSFER: TY20A]

Install in the reverse order of removal.

UNIT REMOVAL AND INSTALLATION

TRANSFER ASSEMBLY

Exploded View

INFOID:000000006260406

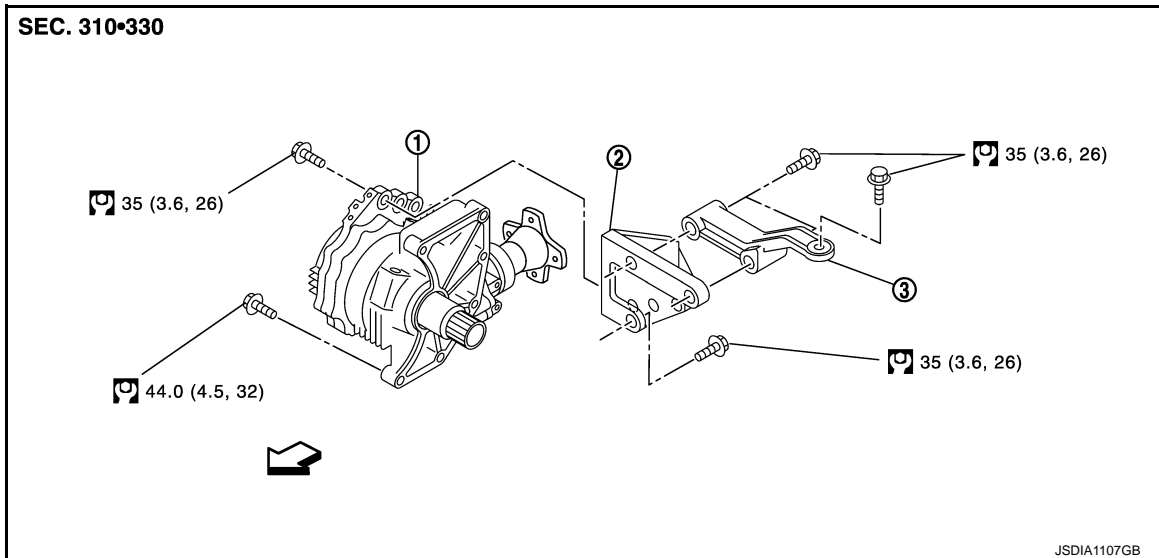

1. Transfer assembly

2. Transfer gusset

3. Rear gusset

Vehicle front

Refer to [GI-4, "Components"](#) for symbols not described on the above.

Removal and Installation

INFOID:000000006260407

REMOVAL

1. Remove extension cowl top panel (lower and upper). Refer to [EXT-20, "Exploded View"](#).
 2. Remove battery and battery tray.
 3. Remove air duct (inlet), air cleaner case (upper and lower) with mass air flow sensor and air duct assembly. Refer to [EM-31, "Exploded View"](#).
 4. Remove air fuel ratio sensor 1 (bank 1). Refer to [EM-38, "Exploded View"](#).
 5. Remove front road wheel and tires.
 6. Remove splash guards (RH and LH).
 7. Remove engine under cover.
 8. Remove air guide.
 9. Remove front drive shaft (right side). Refer to [FAX-43, "Exploded View"](#).
- CAUTION:**
Be careful not to damage gear ring oil seal inside of transfer.
10. Remove exhaust front tube. Refer to [EX-5, "Exploded View"](#).
 11. Separate the rear propeller shaft. Refer to [DLN-82, "Exploded View"](#).
 12. Disconnect oxygen sensor 2 (bank 1) harness connector.
 13. Remove heat insulator from front suspension member.
 14. Remove three way catalyst (bank 1). Refer to [EM-38, "Exploded View"](#).
- CAUTION:**
Handle carefully to avoid any shock to three way catalyst.
15. Remove power steering tube brackets from front suspension member.
 16. Remove high pressure piping and low pressure hose from power steering gear. Refer to [ST-62, "Exploded View"](#).

TRANSFER ASSEMBLY

< UNIT REMOVAL AND INSTALLATION >

[TRANSFER: TY20A]

CAUTION:

Never let the power steering fluid into the suspension member.

17. Remove rear engine mounting insulator mounting bolt (upper side). Refer to [EM-81, "AWD : Exploded View"](#).

18. Support transaxle assembly with a suitable jack.

CAUTION:

When setting the transmission jack, be careful not to allow it to collide against the drain plug.

19. Support front suspension member with a suitable jack.

20. Remove rear gusset and transfer gusset.

21. Remove rear engine mounting insulator mounting bolt (lower side). Refer to [EM-81, "AWD : Exploded View"](#).

22. Disconnect front and rear engine mounting insulator harness connector and harness clip.

23. Move rear engine mounting insulator to remove rear engine mounting bracket.

CAUTION:

Never damage power steering gear boot.

24. Remove rear engine mounting bracket. Refer to [EM-81, "AWD : Exploded View"](#).

25. Remove LH and RH engine mounting bracket. Refer to [EM-81, "AWD : Exploded View"](#).

26. Remove member stay, front suspension member fixing bolts and nuts. Refer to [FSU-16, "Exploded View"](#).

27. Lower the jack for the front suspension member to the height where the transfer assembly can be removed.

28. Remove bolts fitting transaxle assembly and transfer assembly.

Bolt No.	1	2
Quantity	4	2
Bolt length "ℓ" mm (in)	65 (2.56)	40 (1.57)

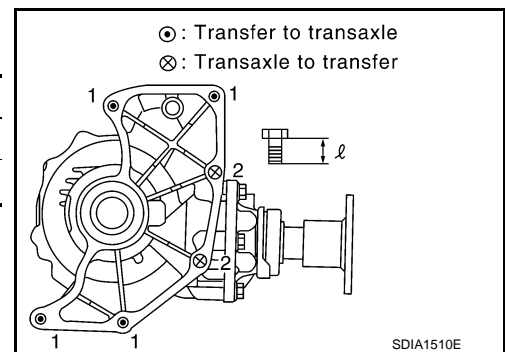

29. Remove transfer assembly from the vehicle.

CAUTION:

- **Never damage air breather hose.**
- **After removing transfer from transaxle, be sure to replace differential side oil seal of the transaxle side with new one. Refer to [TM-171, "AWD : Exploded View"](#).**

INSTALLATION

Note the following, and install in the reverse order of removal.

- When installing the transfer to the transaxle, install the mounting bolts following the standard below.

Bolt No.	1	2
Quantity	4	2
Bolt length "ℓ" mm (in)	65 (2.56)	40 (1.57)

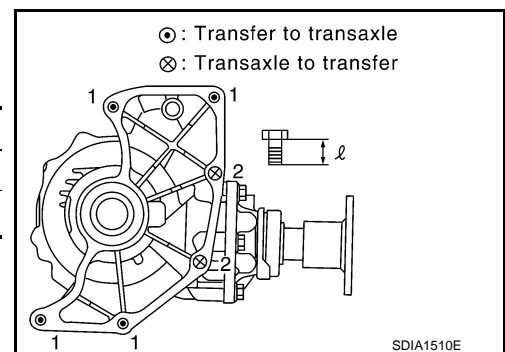

CAUTION:

When installing transfer to transaxle, be careful not to damage oil seal of transaxle.

- Check oil level and check for oil leakage after installation. Refer to [DLN-49, "Inspection"](#).

ADAPTER CASE

< UNIT DISASSEMBLY AND ASSEMBLY >

[TRANSFER: TY20A]

UNIT DISASSEMBLY AND ASSEMBLY

ADAPTER CASE

Exploded View

INFOID:000000006260408

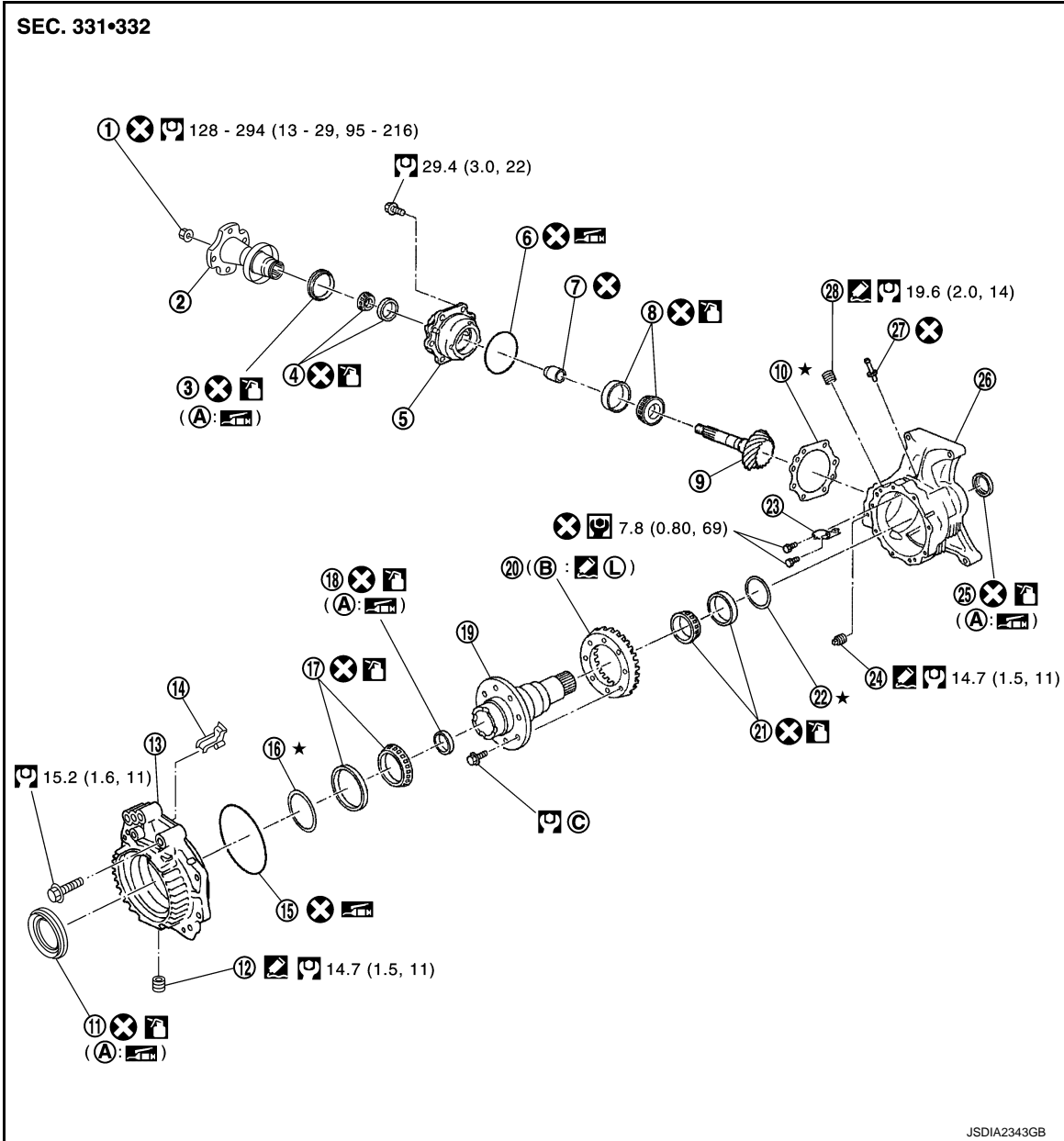

- | | | |
|---|---|--|
| 1. Pinion lock nut | 2. Companion flange | 3. Pinion sleeve oil seal |
| 4. Pinion rear bearing | 5. Pinion sleeve | 6. O-ring |
| 7. Collapsible spacer | 8. Pinion front bearing | 9. Drive pinion |
| 10. Pinion sleeve shim | 11. Adapter case oil seal | 12. Drain plug |
| 13. Adapter case | 14. Oil gutter | 15. O-ring |
| 16. Gear ring bearing adjusting shim (adapter case side) | 17. Gear ring bearing (adapter case side) | 18. Gear ring oil seal |
| 19. Gear ring | 20. Drive gear | 21. Gear ring bearing (transfer case side) |
| 22. Gear ring bearing adjusting shim (transfer case side) | 23. Oil defense | 24. Filler plug |

ADAPTER CASE

< UNIT DISASSEMBLY AND ASSEMBLY >

[TRANSFER: TY20A]

25. Transfer case oil seal

26. Transfer case

27. Breather tube

28. Plug

A. Oil seal lip

B. Screw hole

C. For the tightening torque, refer to [DLN-61, "Assembly"](#).

: Apply gear oil.

: Apply multi-purpose grease.

: Apply Genuine Silicone RTV or equivalent. Refer to [GI-22, "Recommended Chemical Products and Sealants"](#).

: Apply Genuine High Strength Thread Locking Sealant or equivalent. Refer to [GI-22, "Recommended Chemical Products and Sealants"](#).

Refer to [GI-4, "Components"](#) for symbols not described above.

Disassembly

INFOID:000000006260409

1. Remove adapter case mounting bolts (←).

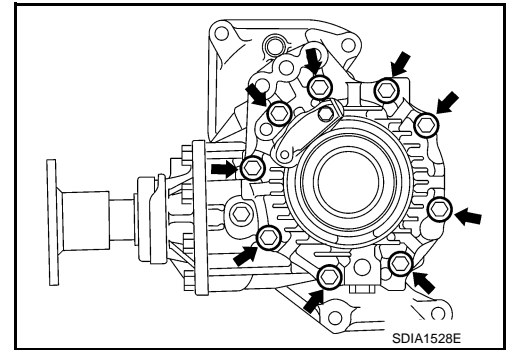

2. Lightly tap adapter case with a plastic hammer to remove adapter case.
3. Remove O-ring from adapter case.

CAUTION:

- Never use a tool.
- Never damage adapter case.

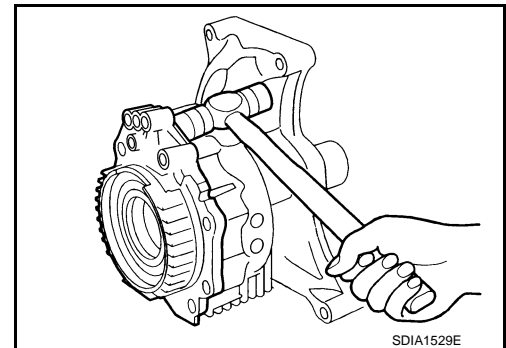

4. Lightly tap the metal part of adapter case oil seal with punch from back side of adapter case to remove adapter case oil seal.

CAUTION:

When removing, never damage the adapter case by scooping it out with a tool.

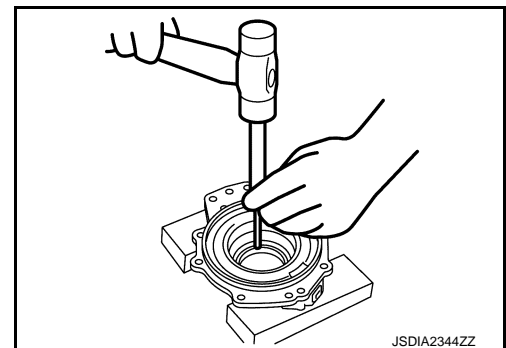

ADAPTER CASE

< UNIT DISASSEMBLY AND ASSEMBLY >

[TRANSFER: TY20A]

- Using a brass rod, tap the gear ring bearing adjusting shim at the cutout on the adapter case to remove the gear ring bearing adjusting shim (adapter case side) and gear ring bearing outer race (adapter case side).

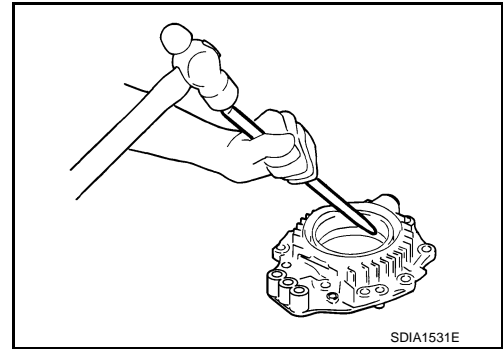

- Remove the oil gutter (1).
- Remove the drain plug.

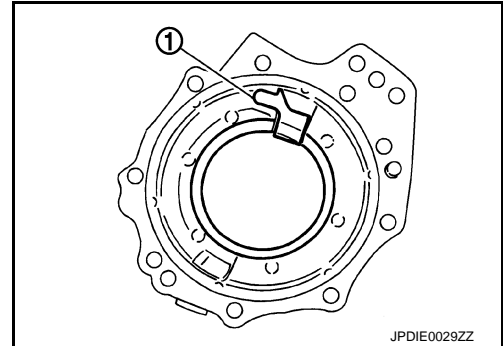

Assembly

INFOID:000000006260410

- Select the gear ring bearing adjusting shim (adapter case side). Refer to [DLN-67, "Adjustment"](#).
- Install the oil gutter.
- Using the drifts, install the selected gear ring bearing adjusting shim (adapter case side) and gear ring bearing outer race (adapter case side).

- A : Drift [SST: ST30720000 (J-25405)]
B : Drift (Commercial Service Tool)

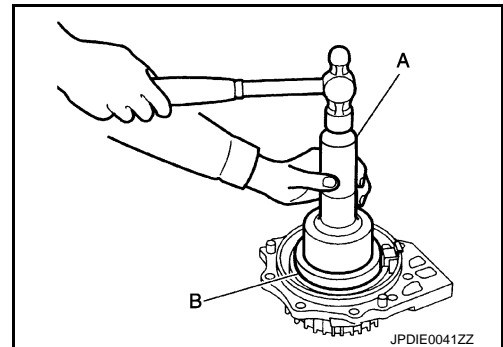

- Using the drift (A) [SST: KV38101700 (—)], drive the adapter case oil seal until it becomes flush with the case end.
Apply multi-purpose grease onto oil seal lips, and gear oil onto the circumference of the oil seal.

CAUTION:

- When checking the total preload torque, measure it without the oil seal, then install the oil seal.
- Never reuse the oil seal.
- Use the drift with larger diameter than outer diameter of oil seal.

- Apply sealant on drain plug and install it to the adapter case. Use Genuine Silicone RTV or equivalent. Refer to [GI-22, "Recommended Chemical Products and Sealants"](#).
- Apply multi-purpose grease lightly and evenly onto an O-ring, and install it to the adapter case.

CAUTION:

- Never reuse the O-ring.
- When installing the O-ring, never use a tool.
- Never damage adapter case.

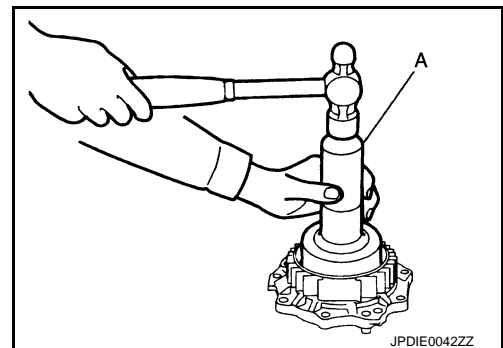

ADAPTER CASE

< UNIT DISASSEMBLY AND ASSEMBLY >

[TRANSFER: TY20A]

7. Install the adapter case to the transfer case, and apply anti-corrosive oil onto threads and seats on the mounting bolts. Tighten to the specified torque.

Bolt symbol	Bolt length "ℓ" mm (in)	Tightening torque N·m (kg·m, ft·lb)
A	45 (1.77)	15.2 (1.6, 11)
B	30 (1.18)	

8. Check backlash, tooth contact, total preload and companion flange runout. Refer to [DLN-67. "Adjustment"](#).

CAUTION:

Measure the total preload without the adapter case oil seal.

Inspection After Disassembly

Check items below. If necessary, replace them with new ones.

CASE

Check the bearing mounting surface for wear, cracks and damages.

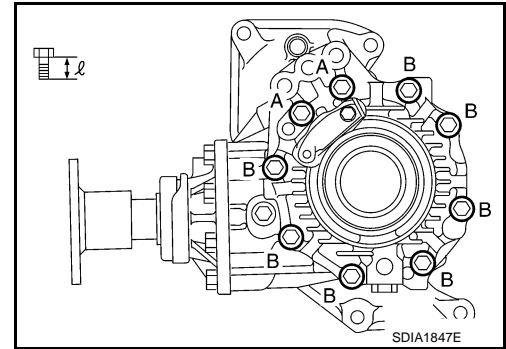

INFOID:000000006260411

GEAR RING

< UNIT DISASSEMBLY AND ASSEMBLY >

[TRANSFER: TY20A]

GEAR RING

Exploded View

INFOID:000000006260412

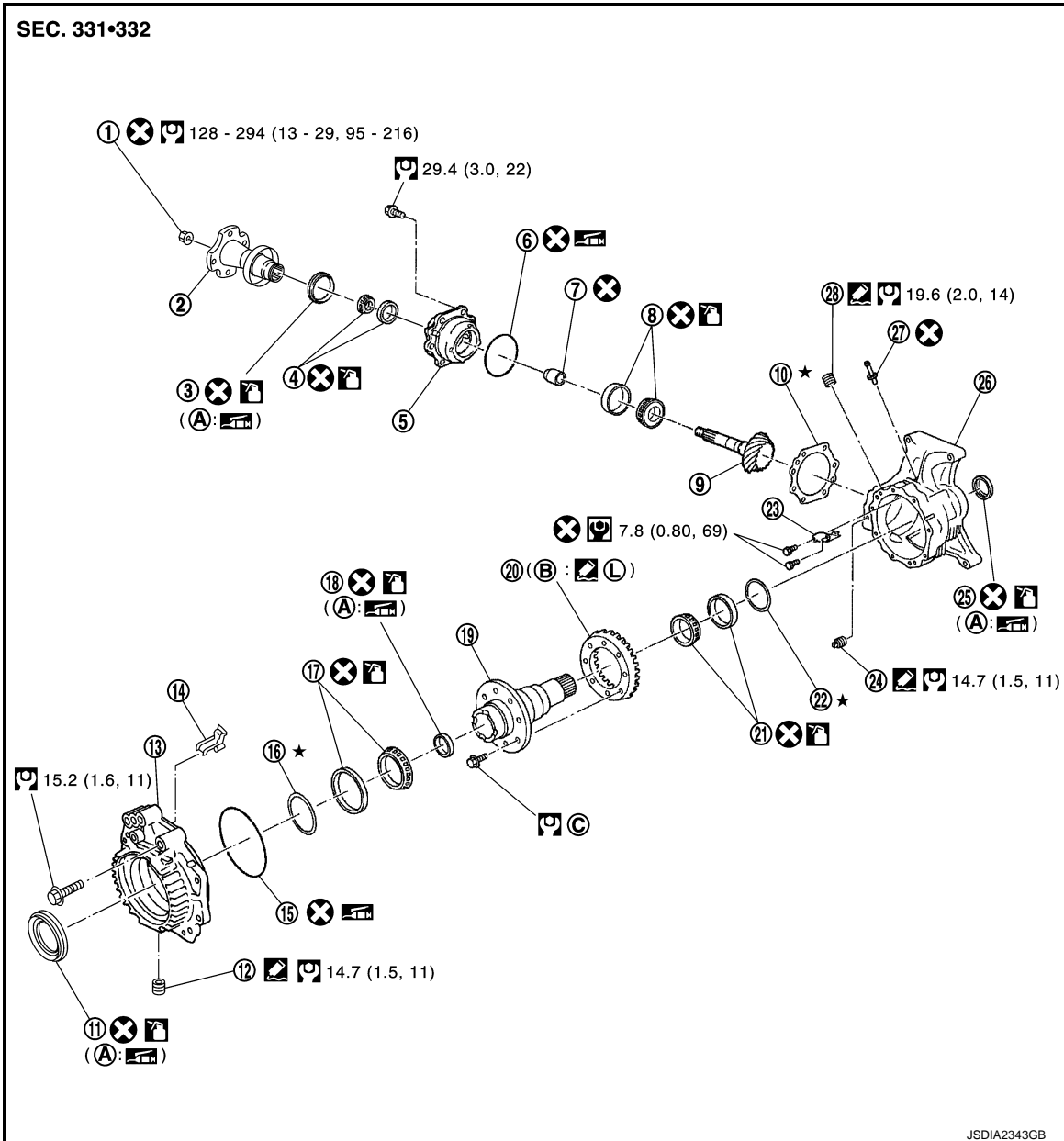

- | | | |
|---|---|--|
| 1. Pinion lock nut | 2. Companion flange | 3. Pinion sleeve oil seal |
| 4. Pinion rear bearing | 5. Pinion sleeve | 6. O-ring |
| 7. Collapsible spacer | 8. Pinion front bearing | 9. Drive pinion |
| 10. Pinion sleeve shim | 11. Adapter case oil seal | 12. Drain plug |
| 13. Adapter case | 14. Oil gutter | 15. O-ring |
| 16. Gear ring bearing adjusting shim (adapter case side) | 17. Gear ring bearing (adapter case side) | 18. Gear ring oil seal |
| 19. Gear ring | 20. Drive gear | 21. Gear ring bearing (transfer case side) |
| 22. Gear ring bearing adjusting shim (transfer case side) | 23. Oil defense | 24. Filler plug |
| 25. Transfer case oil seal | 26. Transfer case | 27. Breather tube |

GEAR RING

< UNIT DISASSEMBLY AND ASSEMBLY >

[TRANSFER: TY20A]

28. Plug

A. Oil seal lip

B. Screw hole

C. For the tightening torque, refer to [DLN-61, "Assembly"](#).

: Apply gear oil.

: Apply multi-purpose grease.

: Apply Genuine Silicone RTV or equivalent. Refer to [GI-22, "Recommended Chemical Products and Sealants"](#).

: Apply Genuine High Strength Thread Locking Sealant or equivalent. Refer to [GI-22, "Recommended Chemical Products and Sealants"](#).

Refer to [GI-4, "Components"](#) for symbols not described above.

Disassembly

INFOID:000000006260413

1. Remove adapter case. Refer to [DLN-56, "Disassembly"](#).
2. Remove drive gear assembly from the transfer case.
3. Remove gear ring bearing outer race (transfer case side) and gear ring bearing adjusting shim (transfer case side) from the transfer case. Refer to [DLN-75, "Disassembly"](#).
4. Remove gear ring bearing inner race (adapter case side) from ring gear shaft with the drift (A) [SST: ST33200000 (J-26082)] and a replacer.

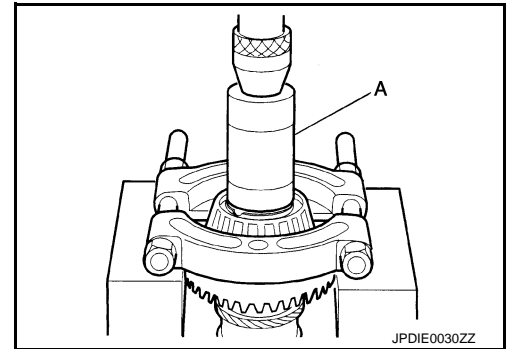

5. Remove gear ring bearing inner race (transfer case side) from gear ring with the drift (A) [SST: ST33061000 (J-8107-2)] and a puller.
6. Remove the drive gear mounting bolts.

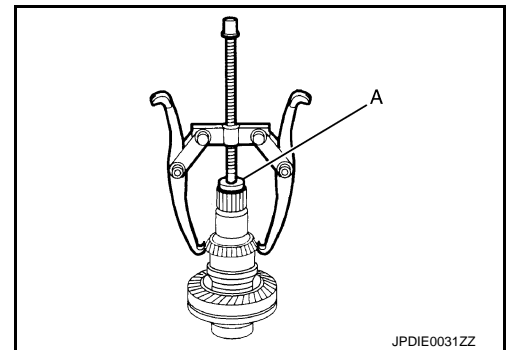

7. Lightly tap adapter case with a plastic hammer to remove drive gear from the gear ring.

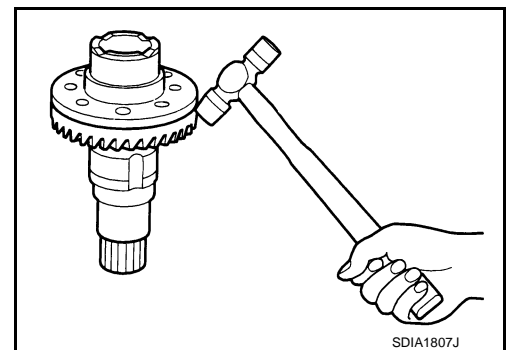

GEAR RING

< UNIT DISASSEMBLY AND ASSEMBLY >

[TRANSFER: TY20A]

8. Remove gear ring oil seal from the gear ring with a puller (A) [SST: KV381054S0 (J-34286)].

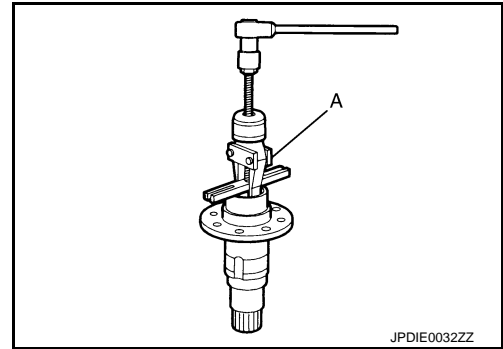

Assembly

INFOID:000000006260414

1. Install gear ring oil seal to the gear ring with the drift (A) [SST: ST33230000 (J-25805-01)]. Apply multi-purpose grease onto oil seal lips, and gear oil onto the circumference of the oil seal.

CAUTION:

- Never reuse the oil seal.
- The oil seal back position after the installation shall be 56.5 mm (2.224 in) from the gear ring end.

2. Select gear ring bearing adjusting shim (transfer case side). Refer to [DLN-67. "Adjustment"](#).

3. Assemble the selected gear ring bearing adjusting shim (transfer case side) and gear ring bearing outer race (transfer case side) to the transfer case. Refer to [DLN-75. "Assembly"](#).

Apply gear oil to the gear ring bearing (transfer case side).

CAUTION:

Never reuse gear ring bearing (transfer case side).

4. Apply thread locking sealant into the thread hole for the drive gear (1).

Use Genuine High Strength Thread Locking Sealant or equivalent. Refer to [GI-22. "Recommended Chemical Products and Sealants"](#).

- a. Completely clean and degrease the drive gear back face, thread holes, and drive gear mounting bolts.

- b. Apply thread locking sealant onto the first and second threads under the thread hole chamfering of the drive gear on 3 or more different points (A).

Use Genuine High Strength Thread Locking Sealant or equivalent. Refer to [GI-22. "Recommended Chemical Products and Sealants"](#).

5. Install the drive gear to gear ring, and apply anti-corrosive oil onto threads and seats on the mounting bolts.

CAUTION:

If the thread locking sealant is applied aside, quickly wipe it off.

6. The drive gear mounting bolts are tightened according to the following torque.

1st step : 27 N·m (2.8 kg·m, 20 ft·lb)

2nd step : 98.5 N·m (10 kg·m, 73 ft·lb)

CAUTION:

Temporary installation before tightening the bolts through to the completion of the tightening should be within 90 seconds.

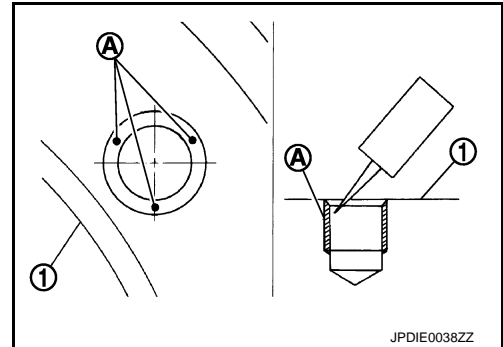
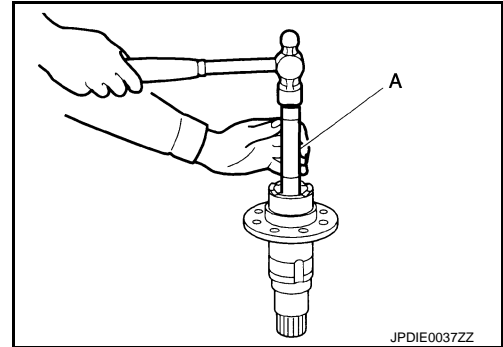

GEAR RING

< UNIT DISASSEMBLY AND ASSEMBLY >

[TRANSFER: TY20A]

7. Apply gear oil to gear ring bearing inner race (transfer case side). Install the gear ring bearing inner race (transfer case side) to gear ring with the drifts.

- A : Drift [SST: ST30720000 (J-25405)]
- B : Drift [SST: ST27863000 (—)]
- C : Drift [SST: KV40101630 (J-35870)]

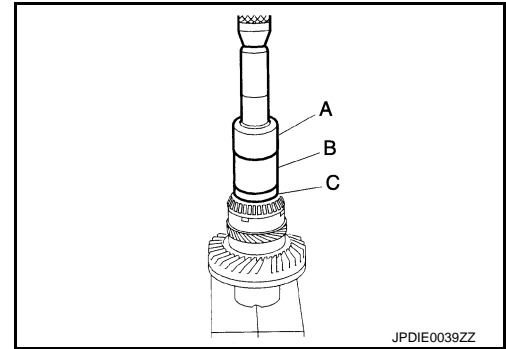

8. Install gear ring bearing inner race (adaptor case side) with the drifts.

- A : Drift [SST: ST30720000 (J-25405)]
- B : Drift [SST: KV38102510 (—)]

Apply gear oil to the gear ring bearing (adapter case side).

CAUTION:

Never reuse gear ring bearing (adapter case side).

9. Install the drive gear assembly to the transfer case.
10. Install adapter case. Refer to [DLN-57, "Assembly"](#).
11. Check backlash, tooth contact, total preload and companion flange runout. Refer to [DLN-67, "Adjustment"](#).

CAUTION:

Measure the total preload without the adapter case oil seal.

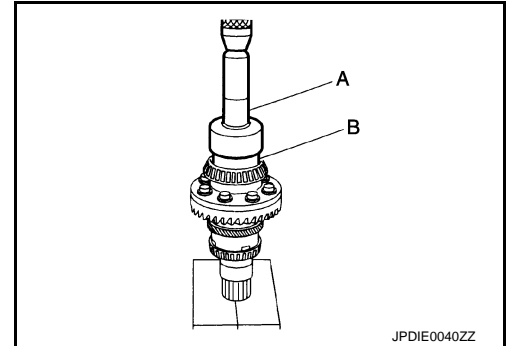

Inspection After Disassembly

INFOID:000000006260415

Check items below. If necessary, replace them with new ones.

GEAR

Check gear face and shaft for wear, cracks, damage, and seizure.

CAUTION:

If malfunction is detected on the drive gear or drive pinion, replace the drive gear and drive pinion as a set.

BEARING

Check for seizure, peeling, wear, corrosion, sticking, unusual noise, roughness in hand turning, and other damage.

CAUTION:

When replacing the bearing, always replace the inner race and outer race as a pair.

SHIM

Check for seizure, damage, and unusual wear.

CASE

Check the bearing mounting surface for wear, cracks and damages.

DRIVE PINION

< UNIT DISASSEMBLY AND ASSEMBLY >

[TRANSFER: TY20A]

DRIVE PINION

Exploded View

INFOID:000000006260416

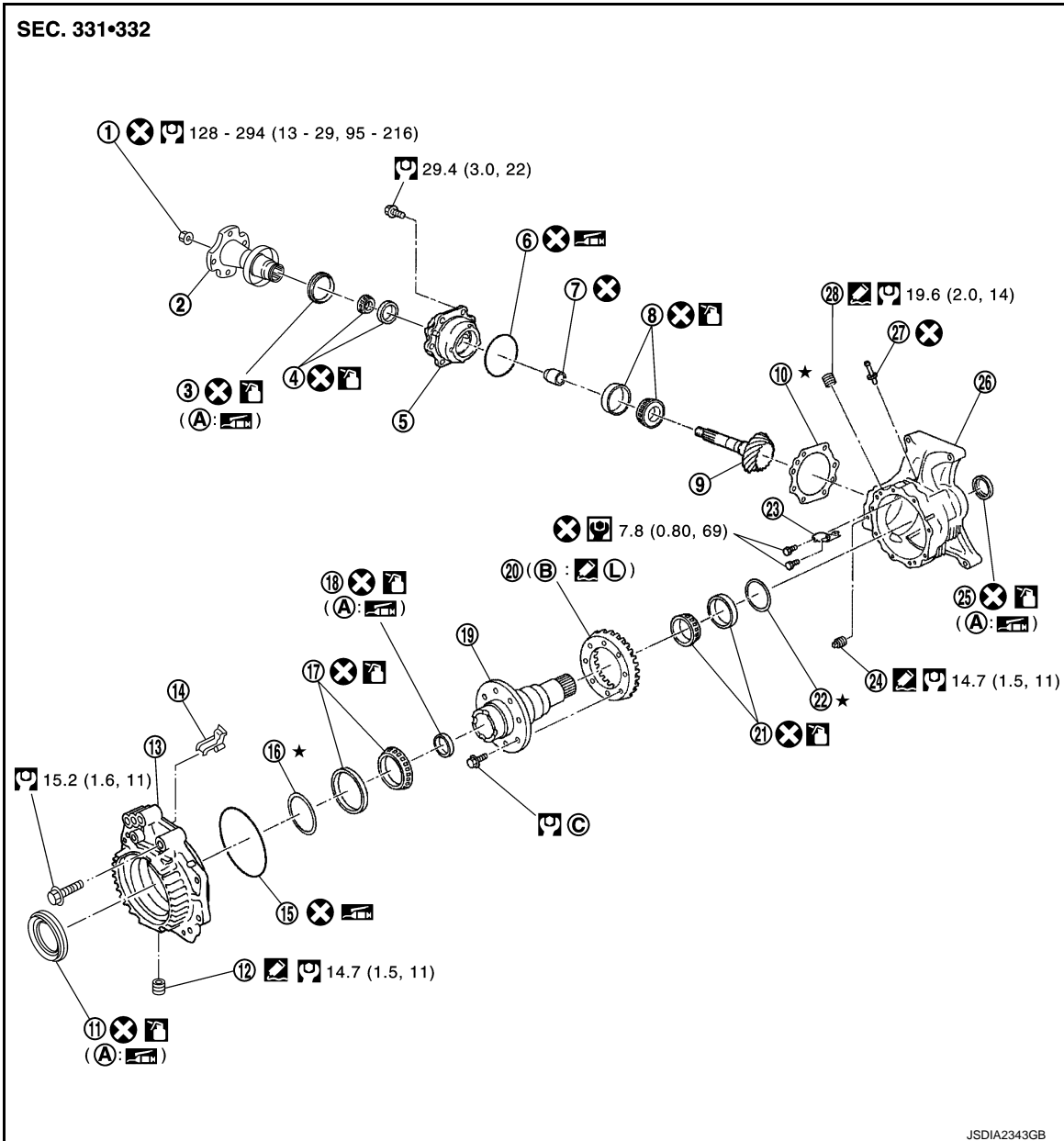

- | | | |
|---|---|--|
| 1. Pinion lock nut | 2. Companion flange | 3. Pinion sleeve oil seal |
| 4. Pinion rear bearing | 5. Pinion sleeve | 6. O-ring |
| 7. Collapsible spacer | 8. Pinion front bearing | 9. Drive pinion |
| 10. Pinion sleeve shim | 11. Adapter case oil seal | 12. Drain plug |
| 13. Adapter case | 14. Oil gutter | 15. O-ring |
| 16. Gear ring bearing adjusting shim (adapter case side) | 17. Gear ring bearing (adapter case side) | 18. Gear ring oil seal |
| 19. Gear ring | 20. Drive gear | 21. Gear ring bearing (transfer case side) |
| 22. Gear ring bearing adjusting shim (transfer case side) | 23. Oil defense | 24. Filler plug |
| 25. Transfer case oil seal | 26. Transfer case | 27. Breather tube |

JSDIA2343GB

DRIVE PINION

< UNIT DISASSEMBLY AND ASSEMBLY >

[TRANSFER: TY20A]

28. Plug

A. Oil seal lip

B. Screw hole

C. For the tightening torque, refer to [DLN-61, "Assembly"](#).

: Apply gear oil.

: Apply multi-purpose grease.

: Apply Genuine Silicone RTV or equivalent. Refer to [GI-22, "Recommended Chemical Products and Sealants"](#).

: Apply Genuine High Strength Thread Locking Sealant or equivalent. Refer to [GI-22, "Recommended Chemical Products and Sealants"](#).

Refer to [GI-4, "Components"](#) for symbols not described above.

Disassembly

INFOID:000000006260417

1. Remove pinion sleeve mounting bolts.

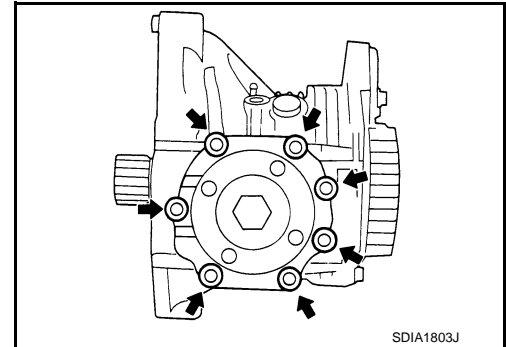

2. Lightly tap adapter case with a plastic hammer to remove pinion sleeve assembly.
3. Remove the pinion sleeve shim.
4. Remove the pinion lock nut.

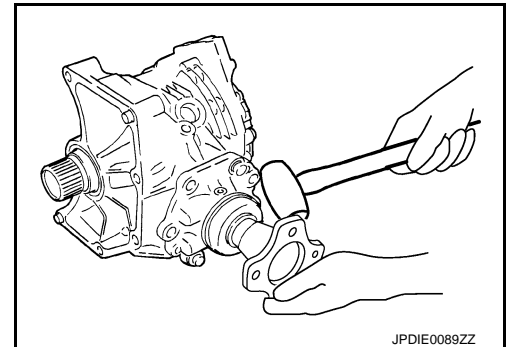

5. Remove drive pinion assembly from pinion sleeve with the drift (A) [SST: ST33220000 (J-25804-01)].
6. Remove companion flange.
7. Remove the O-ring from pinion sleeve.

CAUTION:

- Never use a tool.
- Never damage the pinion sleeve.

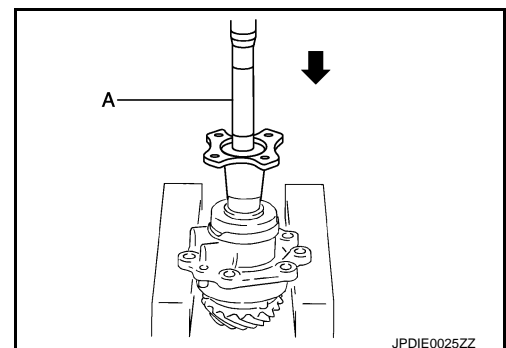

DRIVE PINION

< UNIT DISASSEMBLY AND ASSEMBLY >

[TRANSFER: TY20A]

- Put out the circumference of pinion sleeve oil seal from back side of pinion sleeve with punch to remove pinion sleeve oil seal.

CAUTION:

When removing oil seal, never damage the pinion sleeve by scooping it out with a tool.

- Remove pinion rear bearing inner race.

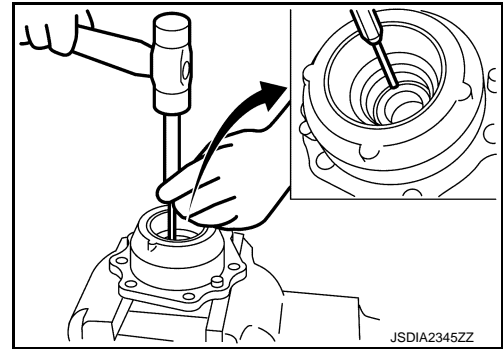

- Remove the pinion rear bearing outer race with the puller (A) [SST: KV381054S0 (J-34286)].

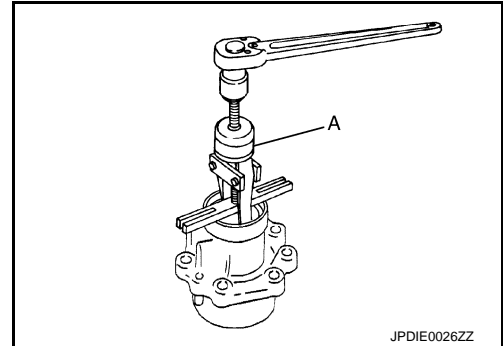

- Remove the pinion front bearing outer race with the puller (A) [SST: KV381054S0 (J-34286)].

- Remove the collapsible spacer from the drive pinion.

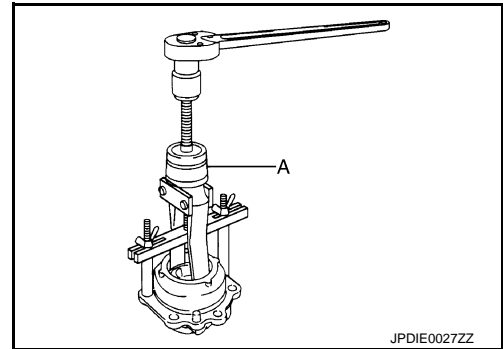

- Using the replacer (A) (commercial service tool), press the pinion front bearing inner race out of the drive pinion.

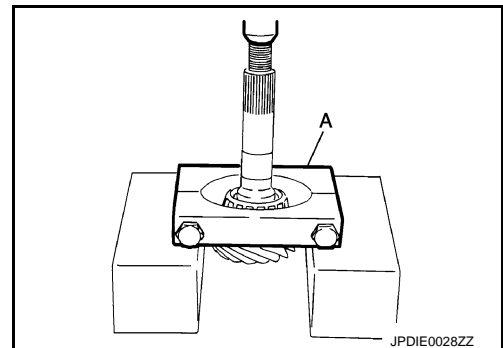

INFOID:000000006260418

Assembly

- Select the pinion sleeve shim. Refer to [DLN-67. "Adjustment"](#).

DRIVE PINION

< UNIT DISASSEMBLY AND ASSEMBLY >

[TRANSFER: TY20A]

2. Install the pinion rear bearing outer race with the drift (A) [SST: KV38100300 (J-25523)].

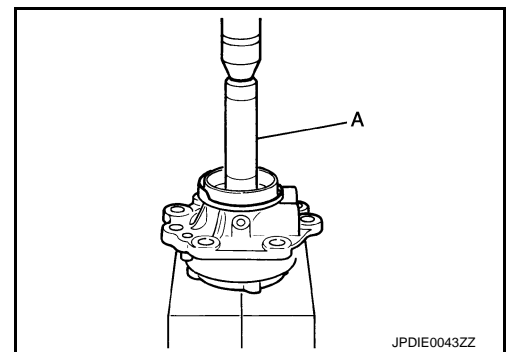

3. Install the pinion front bearing outer race with the drifts.

- A : Drift [SST: ST33400001 (J-26082)]
B : Drift [SST: ST30901000 (J-26010-01)]

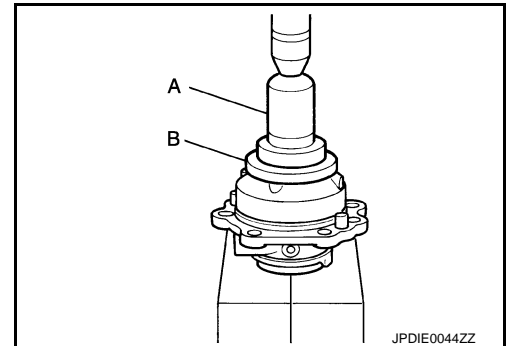

4. Install the pinion front bearing inner race to drive pinion with the drift (A) [SST: ST30901000 (J-26010-01)].
Apply gear oil to the pinion front bearing.

CAUTION:

- Never reuse pinion front bearing.

5. Install a collapsible spacer to the drive pinion.

CAUTION:

Never reuse collapsible spacer.

6. Install the pinion rear bearing inner race to pinion sleeve.
Apply gear oil to the pinion rear bearing.

CAUTION:

- Never reuse pinion rear bearing.

7. Install pinion sleeve oil seal to pinion sleeve with the drift (A) [SST: ST33400001 (J-26082)].
Apply multi-purpose grease onto oil seal lips, and gear oil onto the circumference.

CAUTION:

- Never reuse oil seal.
- Use the drift with larger diameter than outer diameter of oil seal.

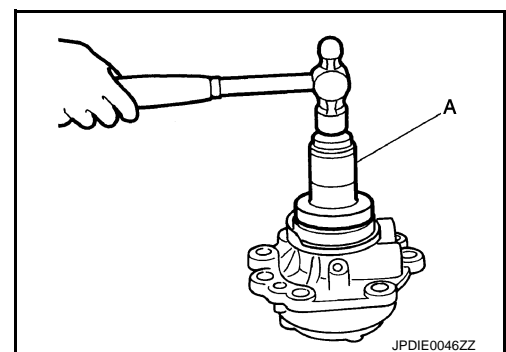
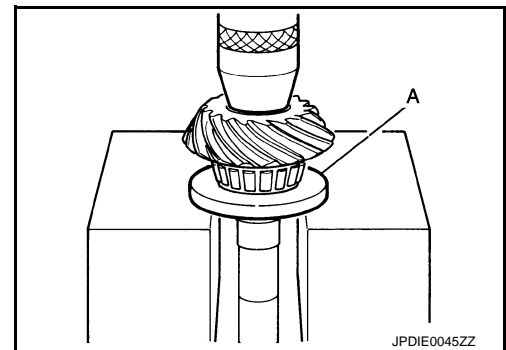

8. Install companion flange to pinion sleeve assembly with the drift (A) [SST: ST33200000 (J-26082)].

9. Apply anti-corrosive oil to the thread and seat of the lock nut, and adjust the pinion lock nut tightening torque and pinion bearing preload torque, using a preload gauge.

Standard

Drive pinion lock nut tighten torque : 128 – 294 N·m (13 – 29 kg·m, 95 – 216 ft·lb)

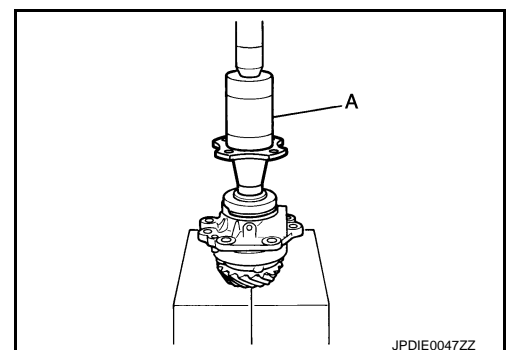

DRIVE PINION

< UNIT DISASSEMBLY AND ASSEMBLY >

[TRANSFER: TY20A]

Standard

Drive pinion bearing preload : Refer to [DLN-78, "Pre-load Torque"](#).

CAUTION:

- Never reuse lock nut.
- If specified preload torque is exceeded, replace the collapsible spacer and tighten again. Never loosen the pinion lock nut for further preload torque adjustment.

10. Apply multi-purpose grease lightly and evenly onto an O-ring, and install it to the pinion sleeve.

CAUTION:

- Never reuse O-ring.
- When installing O-ring, never use a tool.
- Never damage the pinion sleeve.

11. Assemble the selected pinion sleeve shim.

12. Install the pinion sleeve assembly, and apply anti-corrosive oil onto thread and seats on the mounting bolts. Tighten to the specified torque. Refer to [DLN-63, "Exploded View"](#).

13. Check backlash, tooth contact, total preload and companion flange runout. Refer to [DLN-67, "Adjustment"](#).

CAUTION:

Measure the total preload without the adapter case oil seal.

Adjustment

INFOID:000000006260419

BACKLASH

1. Install a bolt to the companion flange.
2. Fit a dial indicator onto the bolt.
3. Measure the circumference backlash of the companion flange, and Check that it satisfies the standard below.

Backlash : Refer to [DLN-78, "Backlash"](#).

- If measured value is out of the specification, disassemble it to check and adjust each part.

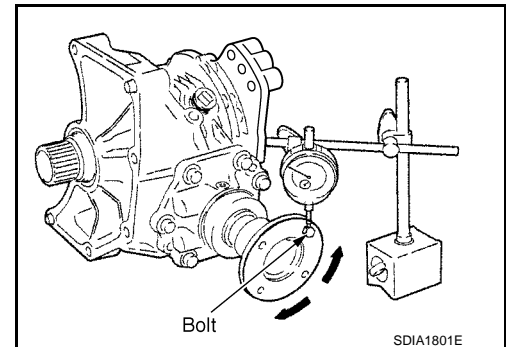

TOOTH CONTACT

1. Remove the pinion sleeve assembly. Refer to [DLN-64, "Disassembly"](#).

2. Apply red lead to the drive gear.

CAUTION:

Apply red lead to both the faces of 3 to 4 gears at 4 locations evenly spaced on the drive gear.

3. Install the pinion sleeve shims and pinion sleeve assembly. Refer to [DLN-65, "Assembly"](#).

4. Remove the plug on the upper side of the transfer case. When installing plug, apply sealant on screw part, and tighten it at the specified torque. Refer to [DLN-63, "Exploded View"](#).

Use Genuine Silicone RTV or equivalent. Refer to [GI-22, "Recommended Chemical Products and Sealants"](#).

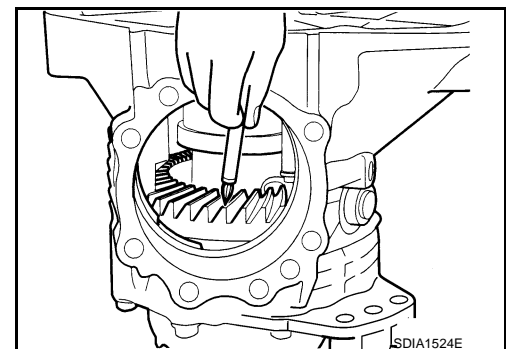

DRIVE PINION

< UNIT DISASSEMBLY AND ASSEMBLY >

[TRANSFER: TY20A]

- Rotate the companion flange back and forth several times, and check the drive pinion gear to drive gear tooth contact by viewing from the plug hole.

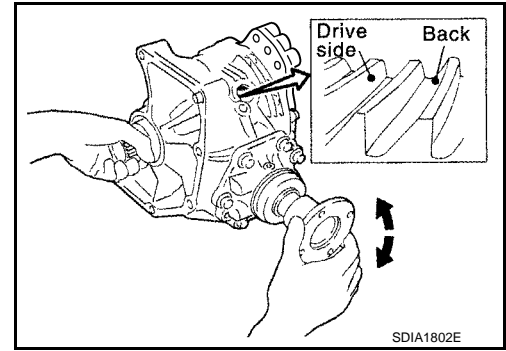

Pinion sleeve shim selection value mm (in)		Tooth contact condition		Need for adjustment
		Drive side	Back	
↑ Thicker	+0.12 (+0.0047)	Heel side 	Toe side 	Yes
	+0.09 (+0.0035)			
	+0.06 (+0.0024)			
	+0.03 (+0.0012)			
↓ Thinner	0 (0.0)			No
	-0.03 (-0.0012)			
	-0.06 (-0.0024)			
	-0.09 (-0.0035)			
	-0.12 (-0.0047)			

- If tooth contact is poorly adjusted, adjust pinion height (dimension X) in the following manner.

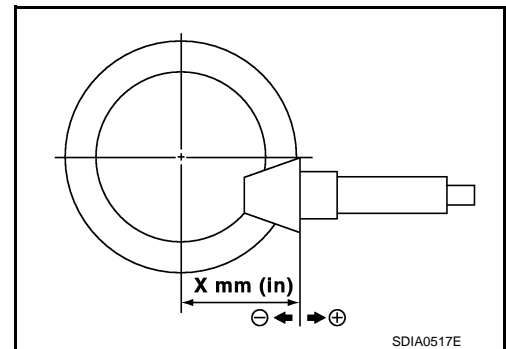

DRIVE PINION

< UNIT DISASSEMBLY AND ASSEMBLY >

[TRANSFER: TY20A]

- If the tooth contact is near the face (face contact), or near the heel (heel contact), thin the pinion sleeve shims to move the drive pinion closer to the drive gear.

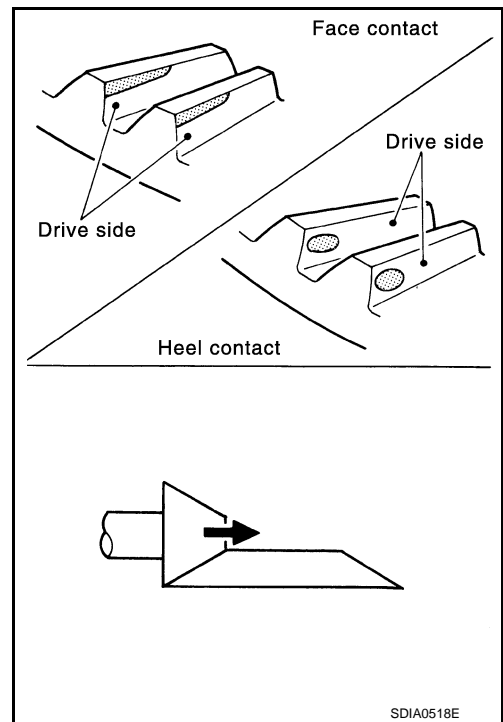

- If the tooth contact is near the flank (flank contact), or near the toe (toe contact), thicken the pinion sleeve shims to move the drive pinion farther from the drive gear.

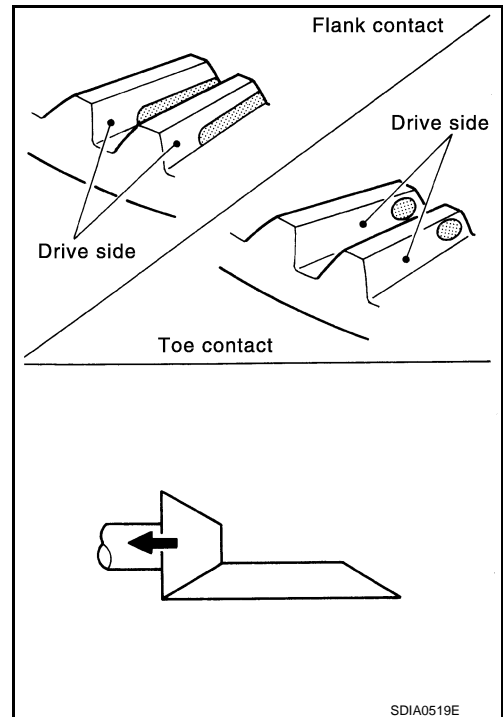

PINION BEARING PRELOAD

1. Remove the pinion sleeve assembly. Refer to [DLN-64, "Disassembly"](#).
2. Rotate the companion flange back and forth 2 to 3 times. Check for unusual noise, rotation malfunction, and other malfunctions.
3. Rotate the companion flange at least 20 times to check for smooth operation of the bearing.

DRIVE PINION

< UNIT DISASSEMBLY AND ASSEMBLY >

[TRANSFER: TY20A]

4. Measure the drive pinion bearing preload with the preload gauge (A) [SST: ST3127S000 (J-25765-A)].

Standard

Preload torque : Refer to [DLN-78, "Preload Torque"](#).

CAUTION:

- Every rotational part shall rotate smoothly with the specified gear oil.
 - Preload torque differs before disassembly and after reassembly.
- If measured value is out of the specification, disassemble the pinion sleeve assembly to check and adjust each part.

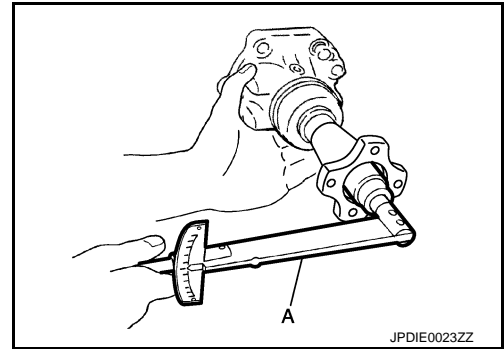

TOTAL PRELOAD

1. Measure pinion bearing preload torque (P1). Refer to [DLN-78, "Preload Torque"](#).
2. Install the pinion sleeve shims and pinion sleeve assembly.
3. Rotate the companion flange at least 20 times to check for smooth operation of the bearing.
4. Measure the total preload with the preload gauge (A) [SST: ST3127S000 (J-25765-A)].

Standard

Total Preload torque : Refer to [DLN-78, "Preload Torque"](#).

CAUTION:

Preload torque differs before disassembly and after reassembly.

- If measured value is out of the specification, disassemble it to check and adjust each part. When measuring the total preload torque after the disassembly, measure it with the transfer case oil seals and gear ring oil seals removed, then install the oil seals.

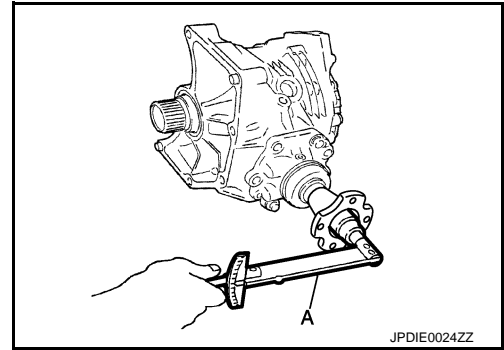

COMPANION FLANGE RUNOUT

1. Fit a dial indicator onto the companion flange face (inner side of the propeller shaft mounting bolt holes).
2. Rotate the companion flange to check for runout.

Limit

Companion flange runout : Refer to [DLN-78, "Companion Flange Runout"](#).

3. Fit a test indicator to the inner side of the companion flange (socket diameter).
4. Rotate the companion flange to check for runout.

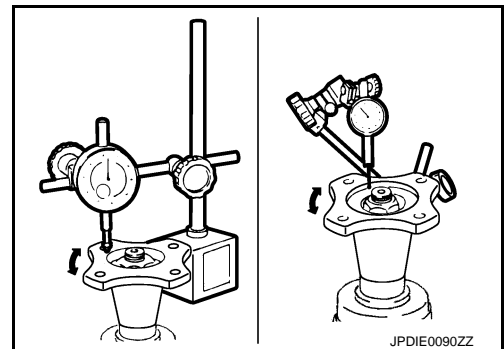

Limit

Companion flange runout : Refer to [DLN-78, "Companion Flange Runout"](#).

5. If the runout value is outside the repair limit, follow the procedure below to adjust.
 - a. While changing the phase between companion flange and drive pinion gear by 90° at a time, check runout and determine which phase angle minimizes the runout.
 - b. If the runout value is still outside of the limit after the phase has been changed, replace the companion flange.
 - c. If the runout is out of the specification after replacement of companion flange, adjust the assembly status of the pinion bearings and drive pinion gear, or replace the pinion bearings.

DRIVE PINION

< UNIT DISASSEMBLY AND ASSEMBLY >

[TRANSFER: TY20A]

SELECTING ADJUSTING SHIM

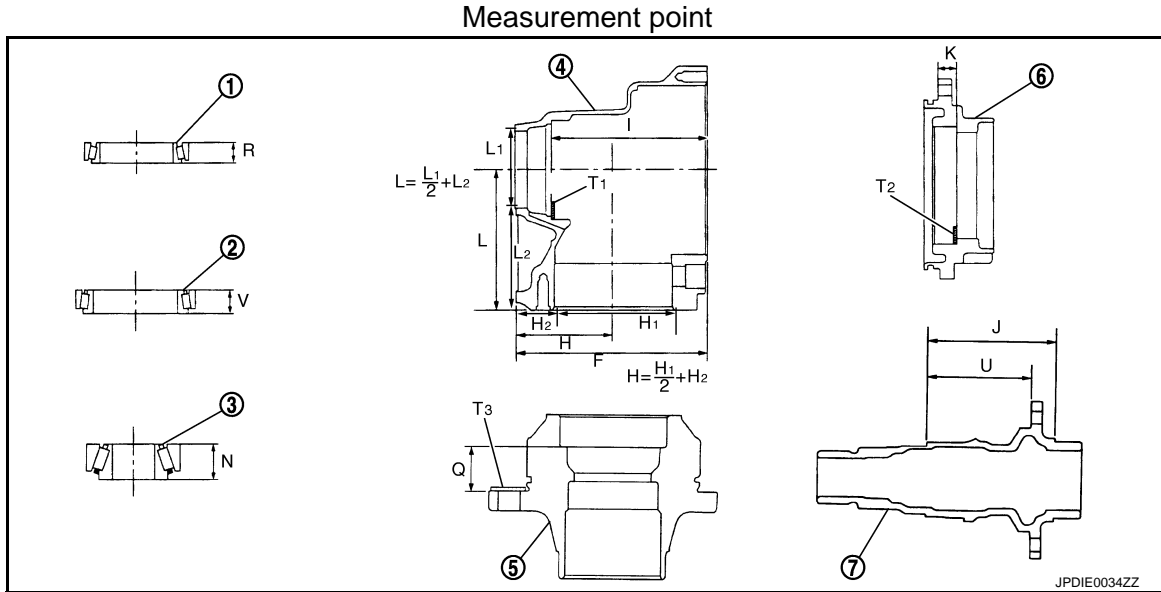

- | | | |
|---|--|-------------------------|
| 1. Gear ring bearing (transfer case side) | 2. Gear ring bearing (adapter case side) | 3. Pinion front bearing |
| 4. Transfer case | 5. Pinion sleeve | 6. Adapter case |
| 7. Gear ring | | |

Gear Ring Bearing Adjusting Shim (Transfer Case Side)

1. Measure F, H, I, R and U shown in the measurement points.
2. Convert the values F, H, I, R and U according to the standards below.

F: Value obtained by subtracting 163.00 mm (6.42 in) from the reading [in increments of 0.01 mm (0.0004 in)].

H: Value obtained by subtracting 83.00 mm (3.268 in) from the reading [in increments of 0.01 mm (0.0004 in)].

I: Value obtained by subtracting 131.90 mm (5.19 in) from the reading [in increments of 0.01 mm (0.0004 in)].

R: Value obtained by subtracting 17.00 mm (0.6693 in) from the reading [in increments of 0.01 mm (0.0004 in)].

U: Value obtained by subtracting 89.50 mm (3.5236 in) from the reading [in increments of 0.01 mm (0.0004 in)].

3. Check dimension Z on the drive gear side face.

NOTE:

Dimension Z indicates the difference between the optimum engagement and the standard dimensions in increments of 0.01mm (0.0004 in) written on the drive gear side face.

4. Use the formula below to calculate gear ring bearing adjusting shim (transfer case side) thickness T1.

$$T_1 = (I - F + H + Z - U - R) \times 0.01 \text{ mm (0.0004 in)} + 1.49 \text{ mm (0.0587 in)}$$

5. Select the gear ring bearing adjusting shim (transfer case side).

CAUTION:

- Only one adjusting shim can be selected.
- If no adjusting shim with the calculated value is available, select the thicker and closest one.

Gear Ring Bearing Adjusting Shim (Adapter Case Side)

1. Measure F, H, J, K, U and V shown in the measurement points.
2. Convert the values F, H, J, K, U and V according to the standards below.

DRIVE PINION

< UNIT DISASSEMBLY AND ASSEMBLY >

[TRANSFER: TY20A]

- F: Value obtained by subtracting 163.00 mm (6.42 in) from the reading [in increments of 0.01 mm (0.0004 in)].
- H: Value obtained by subtracting 83.00 mm (3.268 in) from the reading [in increments of 0.01 mm (0.0004 in)].
- J: Value obtained by subtracting 109.50 mm (4.31 in) from the reading [in increments of 0.01 mm (0.0004 in)].
- K: Value obtained by subtracting 14.40 mm (0.5669 in) from the reading [in increments of 0.01 mm (0.0004 in)].
- U: Value obtained by subtracting 89.50 mm (3.5236 in) from the reading [in increments of 0.01 mm (0.0004 in)].
- V: Value obtained by subtracting 17.00 mm (0.6693 in) from the reading [in increments of 0.01 mm (0.0004 in)].

3. Check dimension Z on the drive gear side face.

NOTE:

Dimension Z indicates the difference between the optimum engagement and the standard dimensions in increments of 0.01mm (0.0004 in) written on the drive gear side face.

4. Use the formula below to calculate gear ring bearing adjusting shim (adapter case side) thickness T₂.

$$T_2 = (K + F - H - Z + U - J - V) \times 0.01 \text{ mm (0.0004 in)} + 1.49 \text{ mm (0.0587 in)}$$

5. Select the gear ring bearing adjusting shim (adapter case side).

CAUTION:

- Only one adjusting shim can be selected.
- If no adjusting shim with the calculated value is available, select the thicker and closest one.

Pinion Sleeve Shim

1. Measure L, N and Q shown in the measurement points.
2. Check the dimension S written on the gear end of the drive pinion.

NOTE:

The dimension S indicates the difference between the optimum engagement and the standard dimensions in increments of 0.01 mm (0.0004 in) written on the gear end of the drive pinion.

3. Use the formula below to calculate pinion sleeve shim thickness T₃.

$$T_3 = [74.6 \text{ mm (2.937 in)} + S] + N + Q - L$$

4. Select the pinion sleeve shim.

CAUTION:

Only one pinion sleeve shim can be selected.

Inspection After Disassembly

INFOID:000000006260420

Check items below. If necessary, replace them with new ones.

GEAR

Check gear face and shaft for wear, cracks, damage, and seizure.

CAUTION:

Replace ring gear and drive pinion as a set (hypoid gear set) if any malfunction is detected on the ring gear or drive pinion.

BEARING

Check for seizure, peeling, wear, corrosion, sticking, unusual noise, roughness in hand turning, and other damage.

CAUTION:

Always replace inner race and outer race as a pair when replacing the bearing.

SHIM

Check for seizure, damage, and unusual wear.

DRIVE PINION

< UNIT DISASSEMBLY AND ASSEMBLY >

[TRANSFER: TY20A]

CASE

Check the bearing mounting surface for wear, cracks and damages.

A

B

C

DLN

E

F

G

H

I

J

K

L

M

N

O

P

TRANSFER CASE

< UNIT DISASSEMBLY AND ASSEMBLY >

[TRANSFER: TY20A]

TRANSFER CASE

Exploded View

INFOID:000000006260421

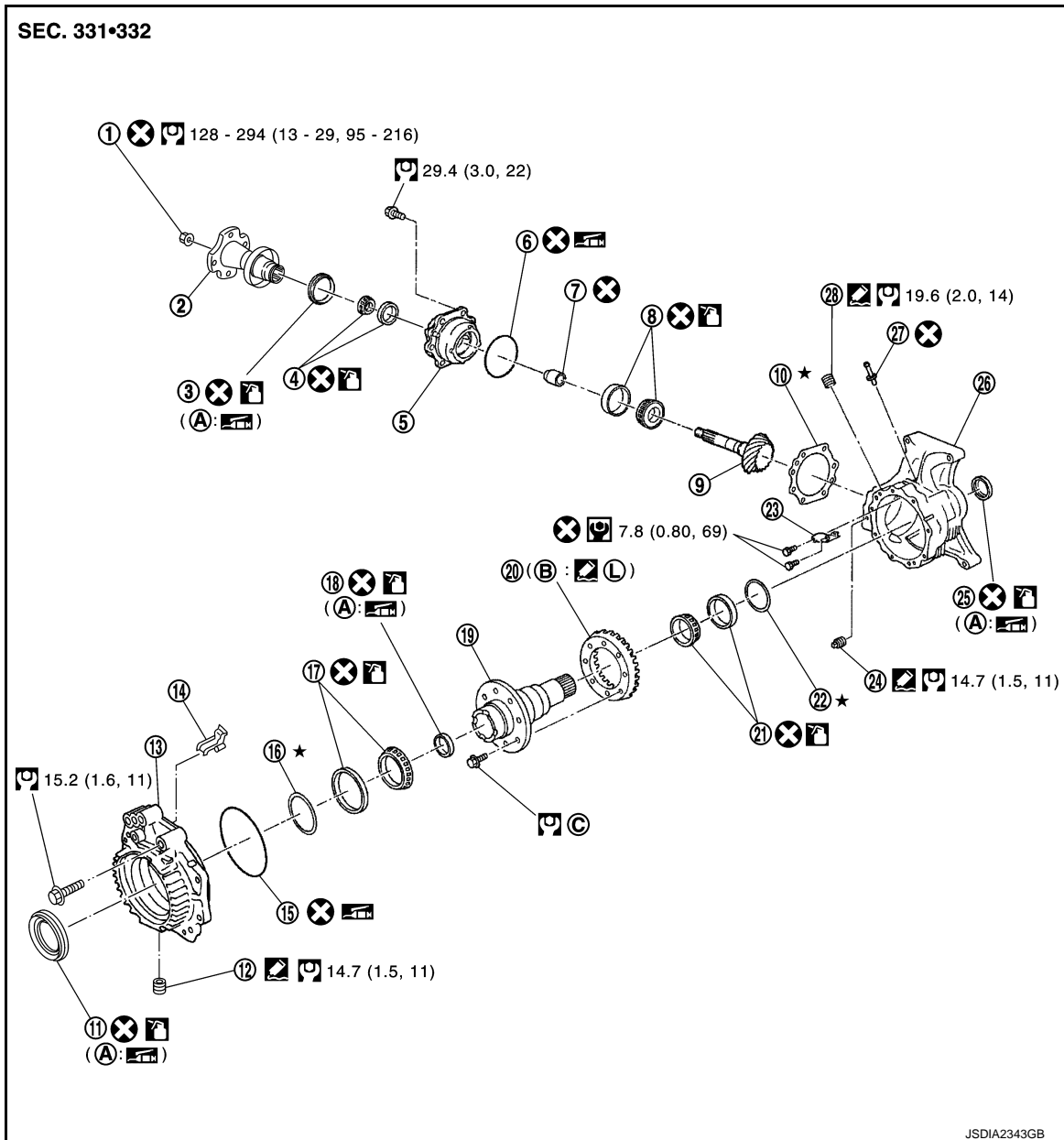

- | | | |
|---|---|--|
| 1. Pinion lock nut | 2. Companion flange | 3. Pinion sleeve oil seal |
| 4. Pinion rear bearing | 5. Pinion sleeve | 6. O-ring |
| 7. Collapsible spacer | 8. Pinion front bearing | 9. Drive pinion |
| 10. Pinion sleeve shim | 11. Adapter case oil seal | 12. Drain plug |
| 13. Adapter case | 14. Oil gutter | 15. O-ring |
| 16. Gear ring bearing adjusting shim (adapter case side) | 17. Gear ring bearing (adapter case side) | 18. Gear ring oil seal |
| 19. Gear ring | 20. Drive gear | 21. Gear ring bearing (transfer case side) |
| 22. Gear ring bearing adjusting shim (transfer case side) | 23. Oil defense | 24. Filler plug |
| 25. Transfer case oil seal | 26. Transfer case | 27. Breather tube |

TRANSFER CASE

< UNIT DISASSEMBLY AND ASSEMBLY >

[TRANSFER: TY20A]

28. Plug

A. Oil seal lip

B. Screw hole

C. For the tightening torque, refer to [DLN-61, "Assembly"](#).

: Apply gear oil.

: Apply multi-purpose grease.

: Apply Genuine Silicone RTV or equivalent. Refer to [GI-22, "Recommended Chemical Products and Sealants"](#).

: Apply Genuine High Strength Thread Locking Sealant or equivalent. Refer to [GI-22, "Recommended Chemical Products and Sealants"](#).

Refer to [GI-4, "Components"](#) for symbols not described above.

Disassembly

INFOID:000000006260422

1. Remove adapter case. Refer to [DLN-56, "Disassembly"](#).
2. Remove gear ring assembly. Refer to [DLN-60, "Disassembly"](#).
3. Remove drive pinion assembly. Refer to [DLN-64, "Disassembly"](#).
4. Using the drift (A) [SST: KV38100200 (—)], push out circumference of transfer case oil seal from front side and drop it to back side, to remove transfer case oil seal.

CAUTION:

Never damage transfer case.

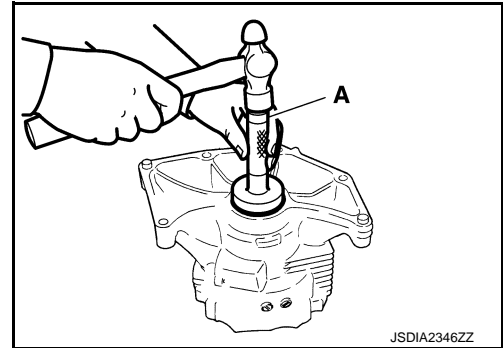

5. Remove the oil defense.

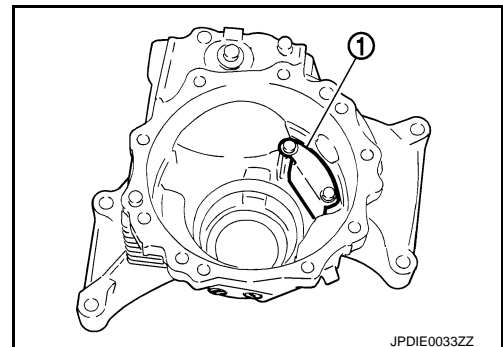

6. Using a brass rod, tap the gear ring bearing adjusting shim (transfer case side) evenly from the 2 cutouts on the transfer case to remove the gear ring bearing adjusting shim (transfer case side) and gear ring bearing outer race (transfer case side).
7. Remove air breather hose from transfer case.
CAUTION:
Never damage air breather hose.
8. Remove air breather tube from transfer case.
9. Remove the filler plug from the transfer case, and then remove each gasket.
10. Remove plug from transfer case.

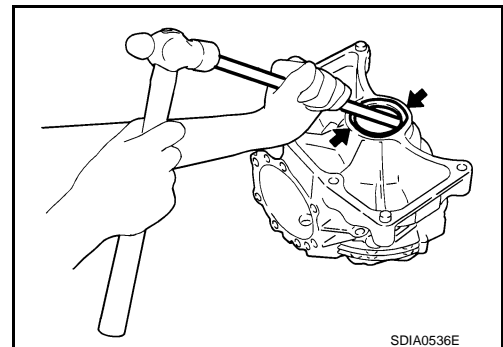

Assembly

INFOID:000000006260423

1. Select the gear ring bearing adjusting shim (transfer case side). Refer to [DLN-67, "Adjustment"](#).

TRANSFER CASE

< UNIT DISASSEMBLY AND ASSEMBLY >

[TRANSFER: TY20A]

2. Install the selected gear ring bearing adjusting shim (transfer side) and gear ring bearing outer race (transfer side) to the transfer case with drifts.
Apply gear oil to the drive pinion bearing (transfer side).

A : Drift [SST: ST30720000 (J-25405)]

B : Drift [SST: KV40101840 (—)]

CAUTION:

- **Never reuse drive pinion bearing (transfer side).**

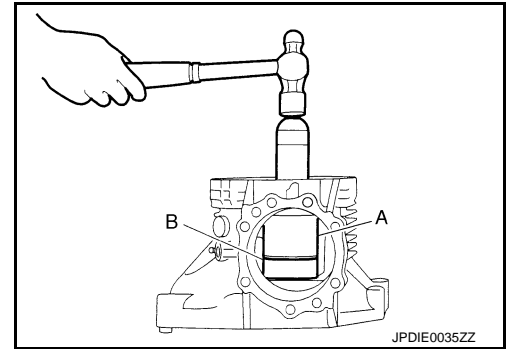

3. Install the oil defense, and tighten the mounting bolts to the specified torque. Refer to [DLN-74, "Exploded View"](#). The clearance (A) between the oil defense and transfer case should be the following.

Clearance between oil defense and transfer case

A : 1.0 - 3.5 mm (0.04 - 0.138 in)

CAUTION:

- **Never reuse mounting bolts.**

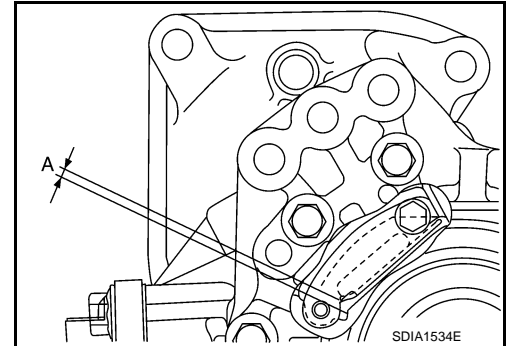

4. Install the transfer case oil seal until it becomes flush with the case end with drift (A) [SST: ST30720000 (J-25405)].

CAUTION:

- **When checking the total preload torque, measure it without the oil seal, then install the oil seal.**
- **Never reuse oil seal.**
- **Apply multi-purpose grease onto oil seal lips, and gear oil onto the circumference of the oil seal.**
- **Use the drift with larger diameter than outer diameter of oil seal.**

5. Apply sealant to filler plug and plug before installing them to the transfer case. Refer to [DLN-63, "Exploded View"](#). Use Genuine Silicone RTV or equivalent. Refer to [GI-22, "Recommended Chemical Products and Sealants"](#).

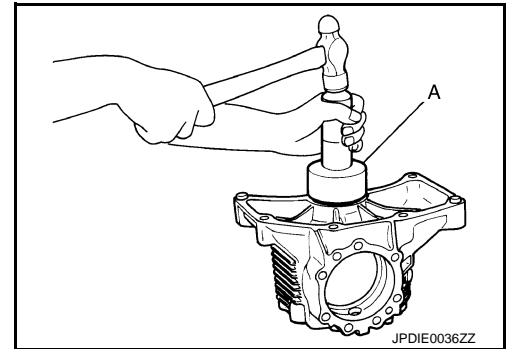

6. Install breather tube to the transfer case.

CAUTION:

- **Never reuse breather tube.**

7. Install drive gear assembly. Refer to [DLN-61, "Assembly"](#).
8. Install adapter case. Refer to [DLN-57, "Assembly"](#).
9. Install drive pinion assembly. Refer to [DLN-65, "Assembly"](#).
10. Install air breather hose.

CAUTION:

- **Check that there are no pinched or restricted areas on the breather hose caused by bending or winding when installing it.**

TRANSFER CASE

< UNIT DISASSEMBLY AND ASSEMBLY >

[TRANSFER: TY20A]

- Be sure to insert air breather hose into breather tube (metal connector) until hose end reaches the tube's base.
- Be sure to insert air breather hose in the hole of the transfer case.

11. Check backlash, tooth contact, total preload and companion flange runout. Refer to [DLN-67, "Adjustment"](#).

CAUTION:

Measure the total preload without the adapter case oil seals.

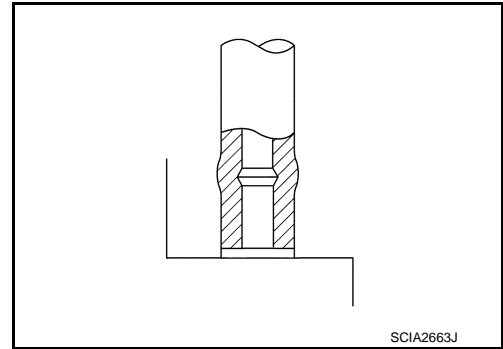

INFOID:000000006260424

Inspection

Check items below. If necessary, replace them with new ones.

CASE

Check the bearing mounting surface for wear, cracks and damages.

A
B
C
DLN
E
F
G
H
I
J
K
L
M
N
O
P

SERVICE DATA AND SPECIFICATIONS (SDS)

< SERVICE DATA AND SPECIFICATIONS (SDS)

[TRANSFER: TY20A]

SERVICE DATA AND SPECIFICATIONS (SDS)

SERVICE DATA AND SPECIFICATIONS (SDS)

General Specifications

INFOID:000000006260425

Applied model	AWD	
	VQ35DE	
	CVT	
Transfer model	TY20A	
Oil capacity (Approx.)	ℓ (US pt, Imp pt)	0.31 (5/8, 1/2)
Gear ratio	0.404	
Number of teeth	Ring gear	42
	Drive pinion	17

Preload Torque

INFOID:000000006260426

BEFORE DISASSEMBLY

Unit: N·m (kg·m, in·lb)

Item	Standard
Drive pinion bearing preload (P1)	0.10 – 0.39 (0.01 – 0.03, 1.0 – 3.0)
Total preload	With all oil seals P1 + 0.16 – 0.22 (0.017 – 0.022, 1.5 – 1.9)
	Without transfer oil seal and adapter case oil seal P1 + 0.06 – 0.12 (0.007 – 0.012, 0.6 – 1.0)

AFTER DISASSEMBLY AND REASSEMBLY

Unit: N·m (kg·m, in·lb)

Item	Standard
Drive pinion bearing preload (P1)	0.50 – 0.99 (0.06 – 0.10, 5 – 8)
Total preload	With all oil seals P1 + 0.49 – 0.63 (0.05 – 0.06, 4.4 – 5.5)
	Without transfer oil seal and adapter case oil seal P1 + 0.27 – 0.41 (0.03 – 0.04, 2.4 – 3.6)

Backlash

INFOID:000000006260427

Unit: mm (in)

Item	Standard
Ring gear to drive pinion	0.17 – 0.24 (0.0067 – 0.0094)

Companion Flange Runout

INFOID:000000006260428

Unit: mm (in)

Item	Limit
Companion flange face (inner side of the propeller shaft bolt holes)	0.15 (0.0059)
Inside of companion flange (socket diameter)	0.2 (0.008)

NOISE, VIBRATION AND HARSHNESS (NVH) TROUBLESHOOTING

< SYMPTOM DIAGNOSIS >

[REAR PROPELLER SHAFT: 3F63A-EDJ75]

SYMPTOM DIAGNOSIS

NOISE, VIBRATION AND HARSHNESS (NVH) TROUBLESHOOTING

NVH Troubleshooting Chart

INFOID:000000006260429

Use the chart below to find the cause of the symptom. If necessary, repair or replace these parts.

Symptom	Possible cause and SUSPECTED PARTS													
	Uneven rotating torque	Center bearing improper installation	Excessive center bearing axial end play	Center bearing mounting (insulator) cracks, damage or deterioration	Excessive joint angle	Rotation imbalance	Excessive runout	DIFFERENTIAL	AXLE AND SUSPENSION	TIRE	ROAD WHEEL	DRIVE SHAFT	BRAKE	STEERING
Noise	x	x	x	x	x	x	x	x	x	x	x	x	x	x
Shake		x			x				x	x	x	x	x	x
Vibration	x	x	x	x	x	x	x		x	x		x		x

x: Applicable

A
B
C
DLN
E
F
G
H
I
J
K
L
M
N
O
P

PREPARATION

[REAR PROPELLER SHAFT: 3F63A-EDJ75]

< PREPARATION >

PREPARATION

PREPARATION

Commercial Service Tool

INFOID:000000006260430

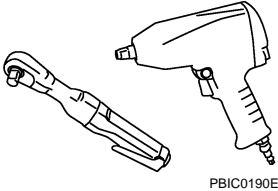
Tool name	Description
<p data-bbox="162 415 267 441">Power tool</p>  <p data-bbox="868 634 941 651">PBIC0190E</p>	<p data-bbox="1063 415 1323 441">Loosening bolts and nuts</p>

REAR PROPELLER SHAFT

< PERIODIC MAINTENANCE >

[REAR PROPELLER SHAFT: 3F63A-EDJ75]

PERIODIC MAINTENANCE

REAR PROPELLER SHAFT

Inspection

INFOID:000000006260431

NOISE

- Check the propeller shaft tube surface for dents or cracks. If damaged, replace propeller shaft assembly.
- If center bearing is noisy or damaged, replace propeller shaft assembly.

VIBRATION

If vibration is present at high speed, inspect propeller shaft runout first.

1. With a dial indicator, measure propeller shaft runout at runout measuring points by rotating final drive companion flange with hands.

Limit

Propeller shaft runout : Refer to [DLN-85, "Propeller Shaft Runout"](#).

2. If runout still exceeds specifications, separate propeller shaft at final drive companion flange or transfer companion flange; then rotate companion flange 90, 180, 270 degrees and install propeller shaft.
3. Check runout again. If runout still exceeds specifications, replace propeller shaft assembly.
4. Check the vibration by driving vehicle.

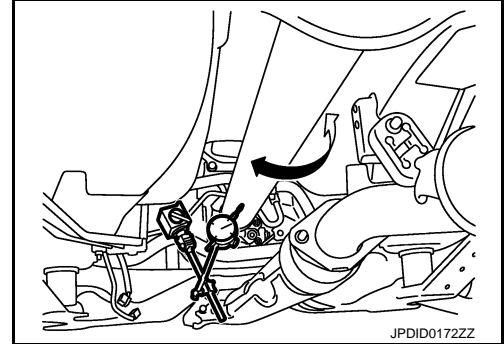

RUNOUT MEASURING POINT

Propeller shaft runout measuring point (Point "△").

↔ : Vehicle front

Dimension

A: 506.5 mm (19.94 in)

B: 497.5 mm (19.59 in)

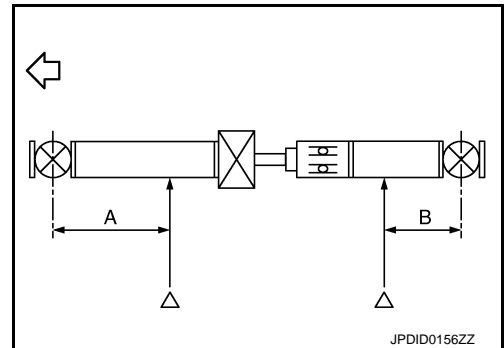

REAR PROPELLER SHAFT

< REMOVAL AND INSTALLATION >

[REAR PROPELLER SHAFT: 3F63A-EDJ75]

REMOVAL AND INSTALLATION

REAR PROPELLER SHAFT

Exploded View

INFOID:000000006260432

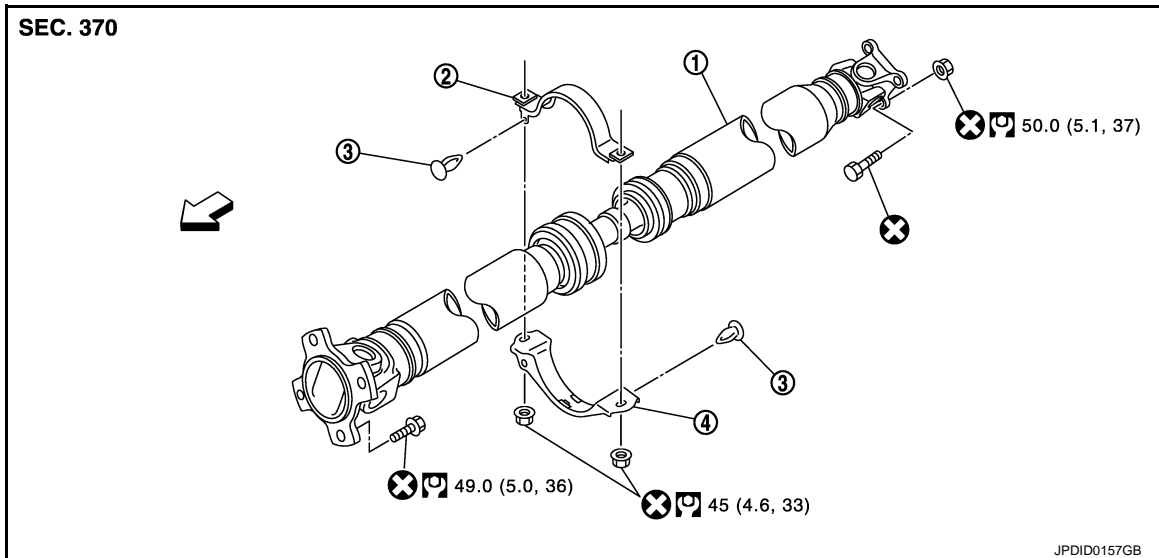

1. Propeller shaft assembly
2. Center bearing mounting bracket (upper)
3. Clip
4. Center bearing mounting bracket (lower)

↔: Vehicle front

Refer to [GI-4, "Components"](#) for symbols in the figure.

Removal and Installation

INFOID:000000006260433

REMOVAL

1. Shift the transaxle to the neutral position, and then release the parking brake.
2. Put matching marks onto propeller shaft flange yoke and final drive and transfer companion flanges.

CAUTION:

For matching marks, use paint. Never damage propeller shaft flange yoke and transfer companion flange.

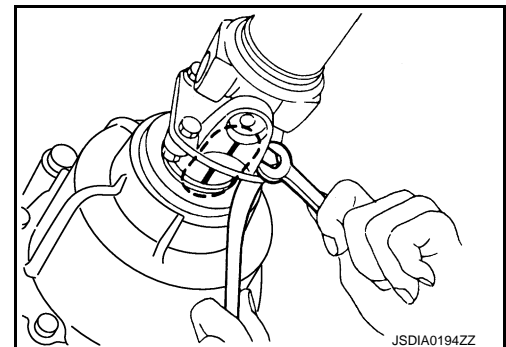

REAR PROPELLER SHAFT

< REMOVAL AND INSTALLATION >

[REAR PROPELLER SHAFT: 3F63A-EDJ75]

- Loosen mounting nuts of center bearing mounting brackets (upper/lower).

↔ : Vehicle front

CAUTION:

Tighten mounting nuts temporarily.

- Remove propeller shaft assembly fixing bolts and nuts.
- Remove center bearing mounting bracket fixing nuts.
- Remove propeller shaft assembly.

CAUTION:

If constant velocity joint was bent during propeller shaft assembly removal, installation, or transportation, its boot may be damaged. Wrap boot interference area to metal part with shop cloth or rubber to protect boot from breakage.

- Remove clips and center bearing mounting bracket (upper/lower).

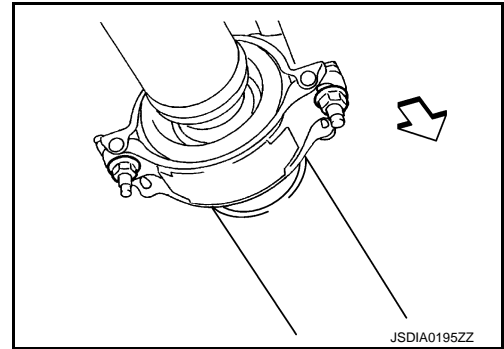

JSDIA0195ZZ

INSTALLATION

Note the following, and install in the reverse order of removal.

- Install center bearing mounting bracket (upper) (1) with its arrow mark (A) facing forward.
- Adjust position of center bearing mounting bracket (upper), center bearing mounting bracket (lower) (2) sliding back and forth to prevent play in thrust direction of center bearing insulator (3). Install center bearing mounting bracket (upper/lower) to vehicle.
- Align matching marks to install propeller shaft assembly to final drive and transfer companion flanges.
- After assembly, perform a driving test to check propeller shaft vibration. If vibration occurred, separate propeller shaft from final drive. Reinstall companion flange after rotating it by 90, 180, 270 degrees. Then perform driving test and check propeller shaft vibration again at each point.

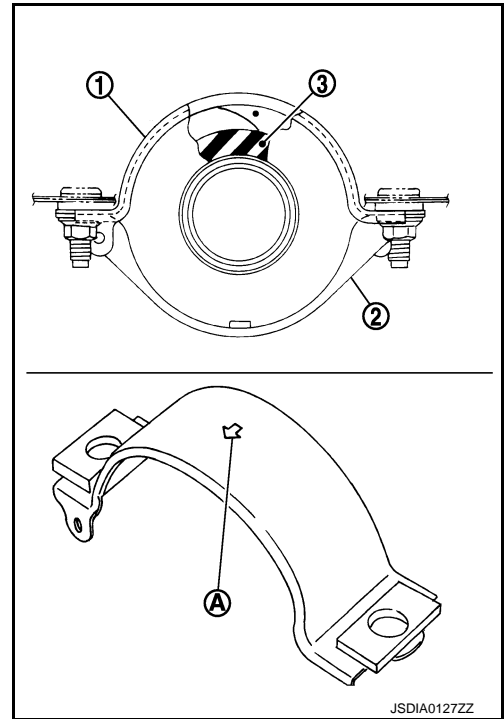

JSDIA0127ZZ

- After tightening the bolts and nuts to the specified torque, check that the bolts (3) on the flange side is tightened as shown in the figure.

1 : Final drive assembly

2 : Propeller shaft assembly

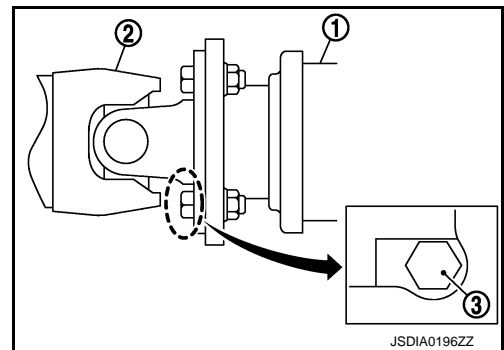

JSDIA0196ZZ

- If propeller shaft assembly or final drive assembly has been replaced, connect them as follows:

A
B
C
DLN
E
F
G
H
I
J
K
L
M
N
O
P

REAR PROPELLER SHAFT

< REMOVAL AND INSTALLATION >

[REAR PROPELLER SHAFT: 3F63A-EDJ75]

- Install propeller shaft (1) while aligning its matching mark (A) with the matching mark (B) of the final drive (2) on the joint as close as possible.
- Tighten mounting bolts and nuts of propeller shaft and final drive to the specified torque.

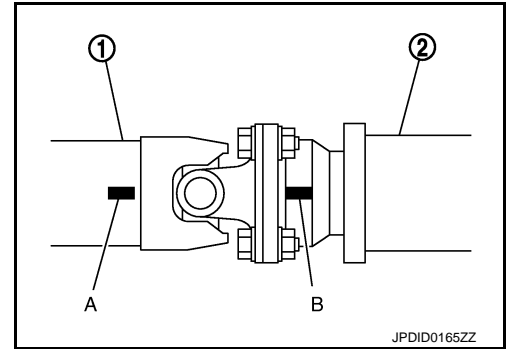

Inspection

APPEARANCE

Check propeller shaft for bend and damage. If damage is detected, replace propeller shaft assembly.

PROPELLER SHAFT RUNOUT

Check propeller shaft runout at measuring points with a dial indicator. If runout exceeds specifications, replace propeller shaft assembly. For measuring point, refer to [DLN-81, "Inspection"](#).

Limit

Propeller shaft runout : Refer to [DLN-85, "Propeller Shaft Runout"](#).

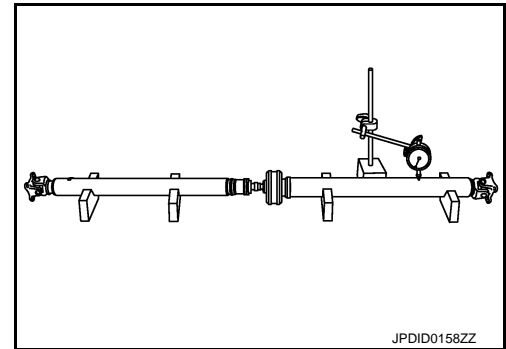

JOURNAL AXIAL PLAY

As shown in the figure, while fixing yoke on one side, check axial play of joint. If it is outside the standard, replace propeller shaft assembly.

Standard

Journal axial play : Refer to [DLN-85, "Journal Axial Play"](#).

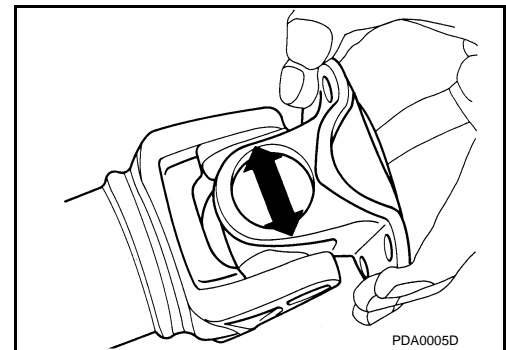

CAUTION:

Never disassemble joints.

CENTER BEARING

Check center bearing for noise and damage. If noise or damage is detected, replace propeller shaft assembly.

CAUTION:

Never disassemble center bearing.

SERVICE DATA AND SPECIFICATIONS (SDS)

< SERVICE DATA AND SPECIFICATIONS (SDS)

[REAR PROPELLER SHAFT: 3F63A-EDJ75]

SERVICE DATA AND SPECIFICATIONS (SDS)

SERVICE DATA AND SPECIFICATIONS (SDS)

General Specifications

INFOID:0000000006260435

Applied model		AWD
		VQ35DE
		CVT
Propeller shaft model		3F63A-EDJ75
Number of joints		3
Type of journal bearings (Non-disassembly type)	1st joint	Shell type
	2nd joint	EDJ type
	3rd joint	Shell type
Coupling method with transfer		Flange type
Coupling method with rear final drive		Flange type
Shaft length	1st (Spider to EDJ joint center)	1142 mm (44.96 in)
	2nd (EDJ joint center to spider)	987 mm (38.86 in)
Shaft outer diameter	1st	63.5 mm (2.500 in)
	2nd	75 mm (2.95 in)

Propeller Shaft Runout

INFOID:0000000006260436

Unit: mm (in)

Item	Limit
Propeller shaft runout	0.8 (0.031)

Journal Axial Play

INFOID:0000000006260437

Unit: mm (in)

Item	Standard
Journal axial play	0 (0)

REAR FINAL DRIVE ASSEMBLY

< SYSTEM DESCRIPTION >

[REAR FINAL DRIVE: R145]

SYSTEM DESCRIPTION

REAR FINAL DRIVE ASSEMBLY

System Diagram

INFOID:000000006260438

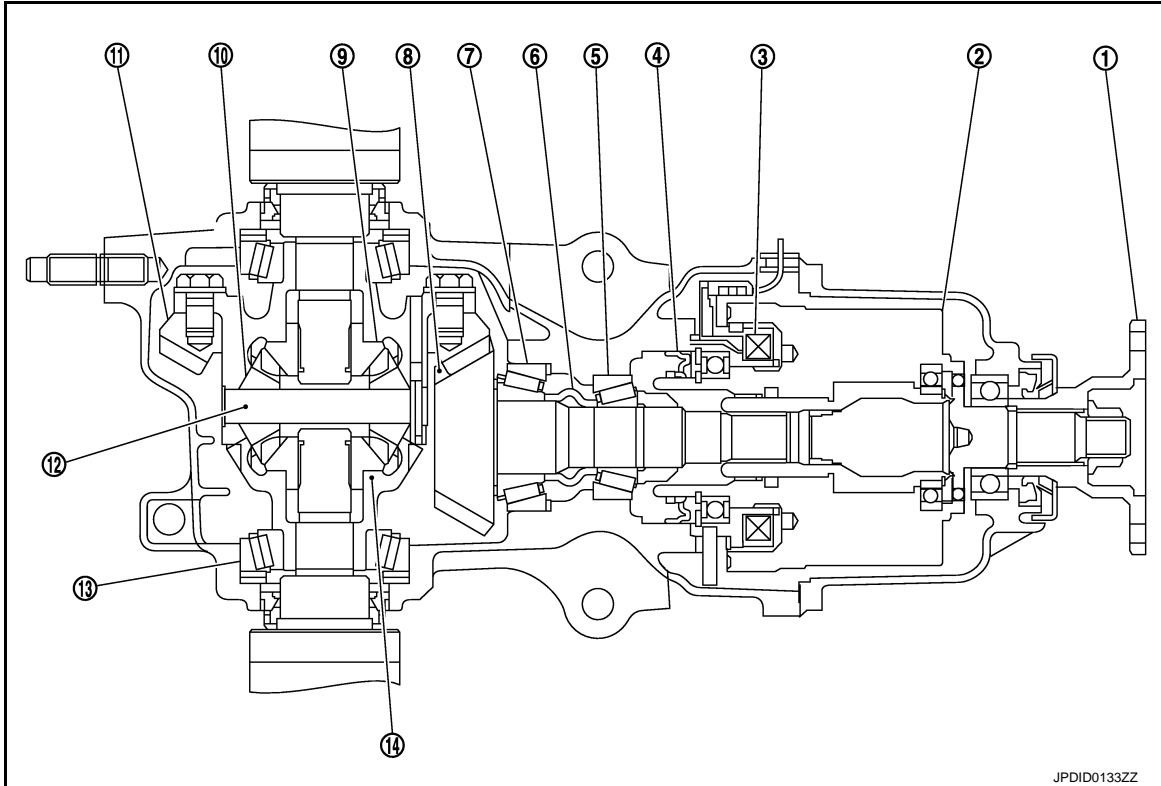

- | | | |
|------------------------|---------------------------------|-----------------------|
| 1. Companion flange | 2. Electric controlled coupling | 3. AWD solenoid |
| 4. Center oil seal | 5. Pinion front bearing | 6. Collapsible spacer |
| 7. Pinion rear bearing | 8. Drive pinion | 9. Side gear |
| 10. Pinion mate gear | 11. Drive gear | 12. Pinion mate shaft |
| 13. Side bearing | 14. Differential case | |

NOISE, VIBRATION AND HARSHNESS (NVH) TROUBLESHOOTING

< SYMPTOM DIAGNOSIS >

[REAR FINAL DRIVE: R145]

SYMPTOM DIAGNOSIS

NOISE, VIBRATION AND HARSHNESS (NVH) TROUBLESHOOTING

NVH Troubleshooting Chart

INFOID:000000006260439

Use the chart below to find the cause of the symptom. If necessary, repair or replace these parts.

Symptom		Possible cause and SUSPECTED PARTS												
Reference	Noise	x	x	x	x	x	x	x	x	x	x	x	x	x
		Gear tooth rough	Gear contact improper	Tooth surfaces worn	Backlash incorrect	Companion flange excessive runout	Gear oil improper	PROPELLER SHAFT	AXLE AND SUSPENSION	TIRE	ROAD WHEEL	DRIVE SHAFT	BRAKE	STEERING
		DLN-123, "Inspection After Disassembly"	DLN-120, "Adjustment"	DLN-123, "Inspection After Disassembly"	DLN-120, "Adjustment"	DLN-120, "Adjustment"	DLN-92, "Inspection"	NVH in DLN section	NVH in FAX, RAX, FSU and RSU sections	NVH in WT section	NVH in WT section	NVH in FAX and RAX section	NVH in BR section	NVH in ST section

x: Applicable

A
B
C
DLN
E
F
G
H
I
J
K
L
M
N
O
P

PRECAUTION

PRECAUTIONS

Service Notice or Precautions for Rear Final Drive

INFOID:000000006260440

- Check for the correct installation status prior to removal or disassembly. If matching marks are required, be certain they never interfere with the function of the parts when applied.
- Overhaul should be done in a clean work area, it is preferable to work in dustproof area.
- Before disassembly, using steam or white gasoline, completely remove sand and mud from the exterior of the unit, preventing them from entering into the unit during disassembly or assembly.
- Check appearance of the disassembled parts for damage, deformation, and unusual wear. Replace them with a new one if necessary.
- Gaskets, seals and O-rings should be replaced any time when the unit is disassembled.
- In principle, tighten bolts or nuts gradually in several steps working diagonally from inside to outside. If tightening sequence is specified, observe it.
- Clean and flush the parts sufficiently and blow-dry them.
- Be careful not to damage sliding surfaces and mating surfaces.
- When applying sealant, remove the old sealant from the mounting surface; then remove any moisture, oil, and foreign materials from the application and mounting surfaces.
- Always use shop paper for cleaning the inside of components.
- Avoid using cotton gloves or shop rags to prevent entering of lint.
- During assembly, observe the specified tightening torque, and apply new gear oil, petroleum jelly, or multi-purpose grease as specified for each vehicle, if necessary.

PREPARATION

[REAR FINAL DRIVE: R145]

< PREPARATION >

PREPARATION

PREPARATION

Special Service Tools

INFOID:000000006260441

The actual shapes of Kent-More tools may differ from those of special service tools illustrated here.

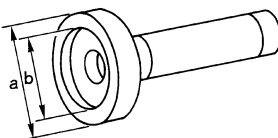
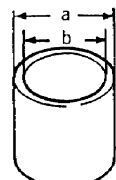
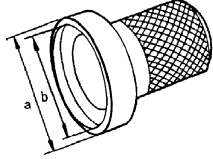
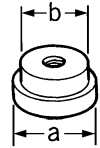
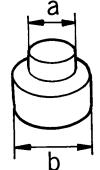
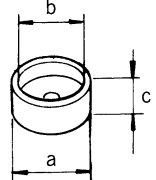
Tool number (Kent-More No.) Tool name	Description
KV38100200 (J-26233) Drift a: 65 mm (2.56 in) dia. b: 49 mm (1.93 in) dia.	 <p style="text-align: center;">ZZA1143D</p> <ul style="list-style-type: none"> • Installing front oil seal • Installing side oil seal
ST27861000 (—) Drift a: 62 mm (2.44 in) dia. b: 52 mm (2.05 in) dia.	Installing front oil seal
ST35271000 (J-26091) Drift a: 72 mm (2.83 in) dia. b: 63 mm (2.48 in) dia.	 <p style="text-align: center;">ZZA0832D</p> Installing center oil seal
KV40100610 (J-26089) Drift a: 63 mm (2.48 in) dia. b: 54.3 mm (2.138 in) dia.	 <p style="text-align: center;">ZZA0814D</p> Removing and installing gear carrier and rear cover (2 pieces are used)
KV4010520 (—) Drift a: 63 mm (2.48 in) dia. b: 54.3 mm (2.138 in) dia.	 <p style="text-align: center;">ZZA1000D</p> Removing side bearing inner race
ST33052000 (—) Drift a: 22 mm (0.87 in) dia. b: 28 mm (1.10 in) dia.	 <p style="text-align: center;">ZZA1023D</p> Removing side bearing inner race
KV4010520 (—) Drift a: 39.7 mm (1.563 in) dia. b: 35 mm (1.38 in) dia. c: 15 mm (0.59 in) dia.	 <p style="text-align: center;">ZZA1133D</p> Installing side bearing inner race

A
B
C
DLN
E
F
G
H
I
J
K
L
M
N
O
P

PREPARATION

< PREPARATION >

[REAR FINAL DRIVE: R145]

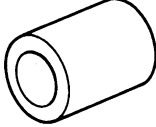
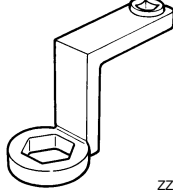
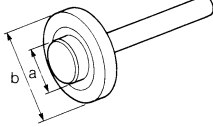
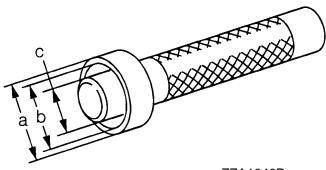
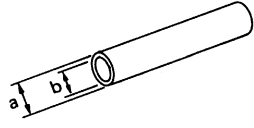
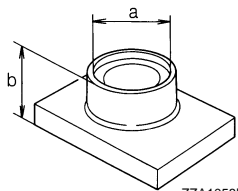
Tool number (Kent-More No.) Tool name	Description
KV38109500 (—) Drive pinion socket	 <p style="text-align: center;">ZZA1205D</p> <ul style="list-style-type: none"> • Removing and installing drive pinion nut • Measuring preload torque
KV38109400 (—) Pinion nut wrench	 <p style="text-align: center;">ZZA1206D</p> <p>Removing and installing drive pinion nut</p>
ST17130000 (—) Drift a: 31.8 mm (1.252 in) dia. b: 58 mm (2.28 in) dia.	 <p style="text-align: center;">ZZA0836D</p> <p>Installing pinion rear bearing outer race</p>
ST33230000 (J-25805-01) Drift a: 51 mm (2.01 in) dia. b: 41 mm (1.61 in) dia. c: 28.5 mm (1.122 in) dia.	 <p style="text-align: center;">ZZA1046D</p> <p>Installing pinion front bearing outer race</p>
ST23860000 (—) Drift a: 38 mm (1.50 in) dia. b: 33 mm (1.30 in) dia.	 <p style="text-align: center;">ZZA0534D</p> <ul style="list-style-type: none"> • Installing pinion rear bearing inner race • Installing pinion front bearing inner race
ST38220000 (—) Press stand a: 63 mm (2.48 in) dia. b: 65 mm (2.56 in) dia.	 <p style="text-align: center;">ZZA1058D</p> <p>Installing pinion front bearing inner race</p>

PREPARATION

< PREPARATION >

[REAR FINAL DRIVE: R145]

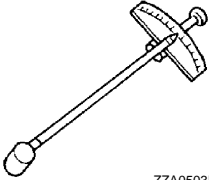
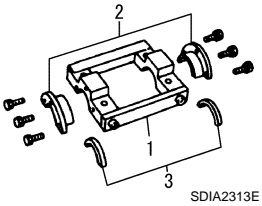
Tool number (Kent-More No.) Tool name	Description	
ST3127S000 (J-25765-A) Preload gauge	 ZZA0503D	A B C
KV381086S1 (—) Dummy cover set 1. KV38108610 (—) Dummy cover 2. KV38108621 (—) Dummy cover spacer 3. KV38108630 (—) Dummy cover shim	 SDIA2313E	DLN E F G

Commercial Service Tools

INFOID:000000006260442

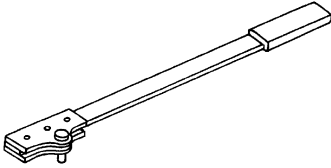
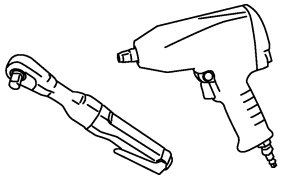
Tool name	Description	
Flange wrench	 NT771	H I J
Power tool	 PBIC0190E	K L M

A
B
C
DLN
E
F
G
H
I
J
K
L
M
N
O
P

PERIODIC MAINTENANCE

REAR DIFFERENTIAL GEAR OIL

Inspection

INFOID:000000006260443

OIL LEAKAGE

Check that oil is not leaking from final drive assembly or around it.

OIL LEVEL

- Remove filler plug (1) and check oil level from filler plug mounting hole as shown in the figure.

CAUTION:

Never start engine while checking oil level.

- Set a new gasket on filler plug and install it on final drive assembly. Refer to [DLN-103, "Exploded View"](#).

CAUTION:

Never reuse gasket.

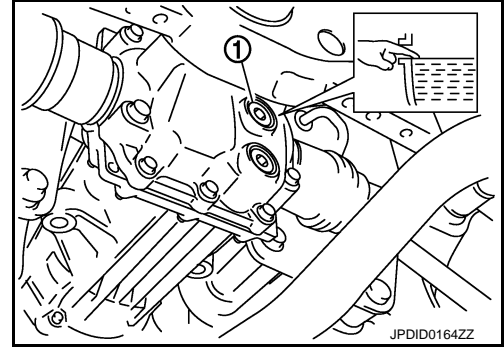

Draining

INFOID:000000006260444

- Stop engine.
- Remove drain plug (1) and drain gear oil.
- Set a new gasket on drain plug and install it to final drive assembly and tighten to the specified torque. Refer to [DLN-103, "Exploded View"](#).

CAUTION:

Never reuse gasket.

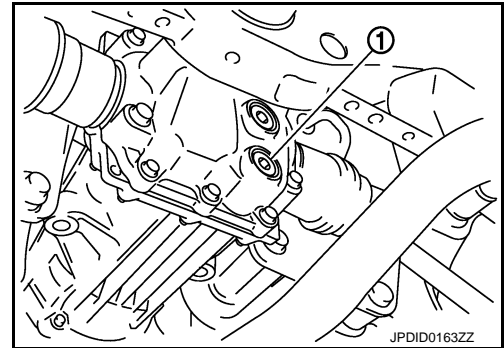

Refilling

INFOID:000000006260445

- Remove filler plug (1). Fill with new gear oil until oil level reaches the specified level near filler plug mounting hole.

Oil grade and viscosity

: Refer to [MA-15, "FOR NORTH AMERICA : Fluids and Lubricants"](#) (for NORTH AMERICA), [MA-16, "FOR MEXICO : Fluids and Lubricants"](#) (for MEXICO).

Oil capacity

: Refer to [DLN-125, "General Specification"](#).

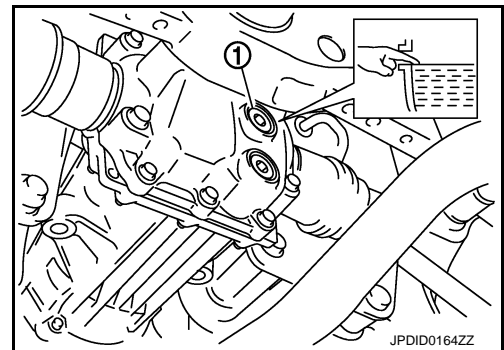

- After refilling oil, check oil level. Set a new gasket to filler plug, then install it to final drive assembly. Refer to [DLN-103, "Exploded View"](#).

CAUTION:

Never reuse gasket.

FRONT OIL SEAL

< REMOVAL AND INSTALLATION >

[REAR FINAL DRIVE: R145]

REMOVAL AND INSTALLATION

FRONT OIL SEAL

Exploded View

INFOID:000000006260446

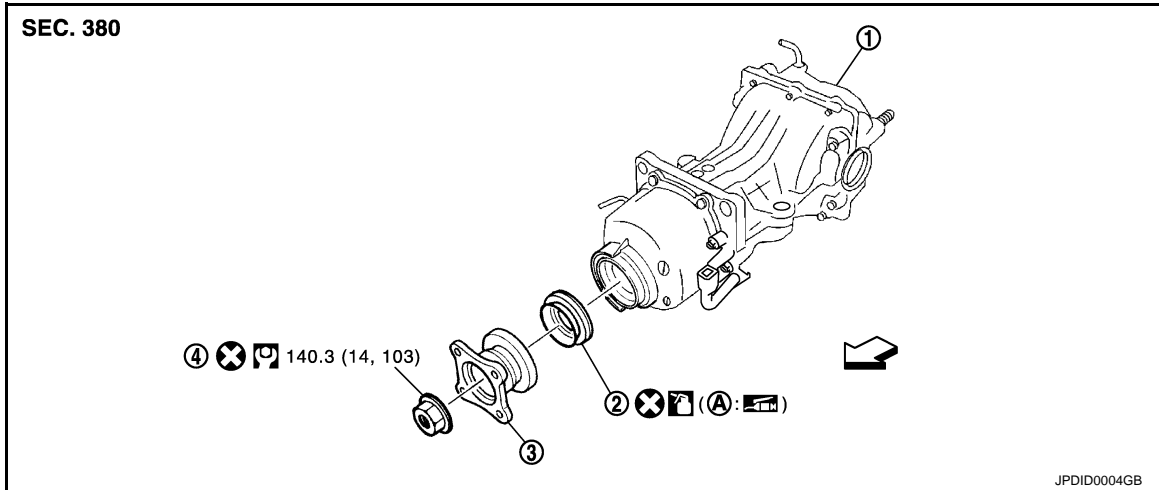

- 1. Final drive assembly
- 2. Front oil seal
- 3. Companion flange
- 4. Companion flange lock nut
- A. Oil seal lip

↔: Vehicle front

: Apply gear oil.

Refer to [GI-4. "Components"](#) for symbols not described above.

Removal and Installation

INFOID:000000006260447

REMOVAL

1. Remove rear propeller shaft. Refer to [DLN-82. "Exploded View"](#).
2. Put matching mark on the thread edge of electric controlled coupling. The matching mark should be in line with the matching mark on companion flange.

CAUTION:

For matching mark, use paint. Never damage electric controlled coupling.

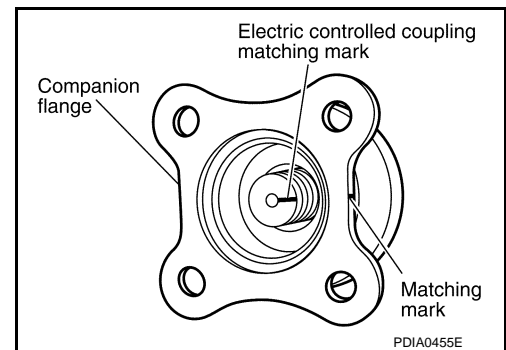

FRONT OIL SEAL

< REMOVAL AND INSTALLATION >

[REAR FINAL DRIVE: R145]

3. Remove companion flange lock nut, using a flange wrench (commercial service tool). Then remove companion flange.

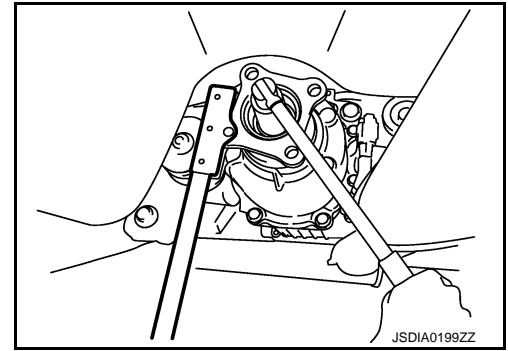

4. Remove front oil seal from coupling cover, using a suitable tool.
CAUTION:
Be careful not to damage coupling cover.

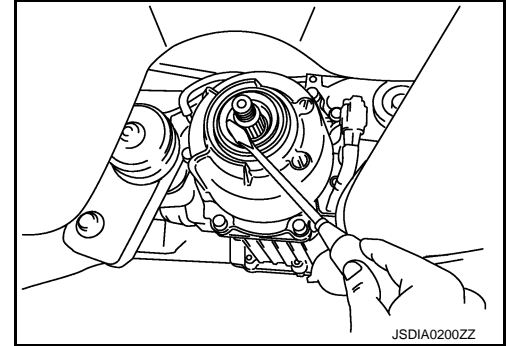

INSTALLATION

1. Install front oil seal until it becomes flush with the coupling cover end, using the drifts.

A : Drift [SST: KV38100200 (J-26233)]

B : Drift [SST: ST27861000 (—)]

CAUTION:

- Never reuse oil seal.
- When installing, never incline oil seal.
- Apply multi-purpose grease onto oil seal lips, and gear oil onto the circumference of oil seal.

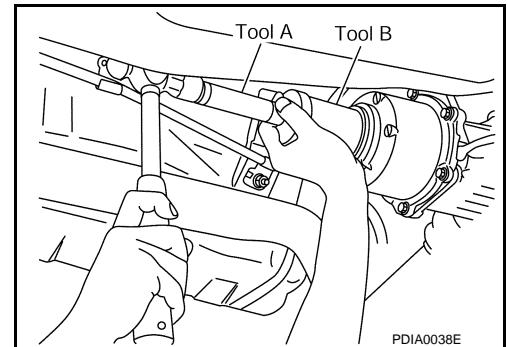

2. Align the matching mark of electric controlled coupling with the matching mark of companion flange, then install the companion flange.
3. Install companion flange lock nut with a flange wrench (commercial service tool), tighten to the specified torque.

CAUTION:

Never reuse companion flange lock nut.

4. Install rear propeller shaft. Refer to [DLN-82, "Exploded View"](#).
5. When oil leaks while removing, check oil level after the installation. Refer to [DLN-92, "Inspection"](#).

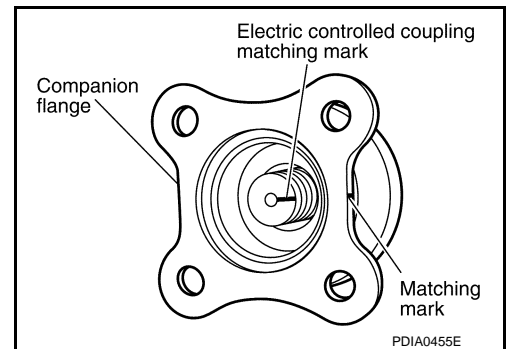

SIDE OIL SEAL

< REMOVAL AND INSTALLATION >

[REAR FINAL DRIVE: R145]

SIDE OIL SEAL

Exploded View

INFOID:000000006260448

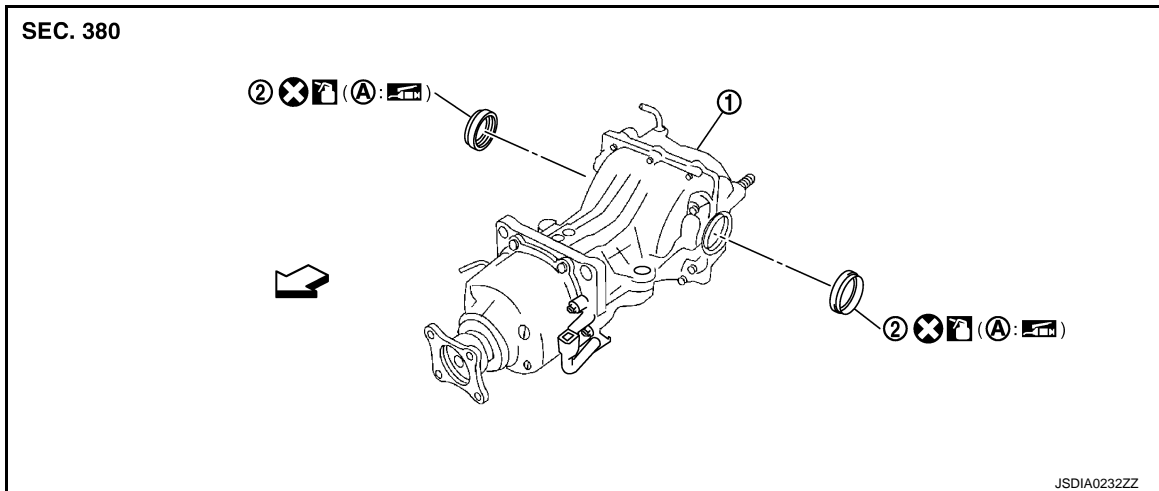

1. Final drive assembly
 2. Side oil seal
- A. Oil seal lip

 Vehicle front

 Apply gear oil.

Refer to [GI-4, "Components"](#) for symbols not described above.

Removal and Installation

INFOID:000000006260449

REMOVAL

1. Remove rear drive shafts with power tool. Refer to [RAX-15, "Exploded View"](#).
2. Remove side oil seals, using a suitable tool.

CAUTION:

Be careful not to damage gear carrier and rear cover.

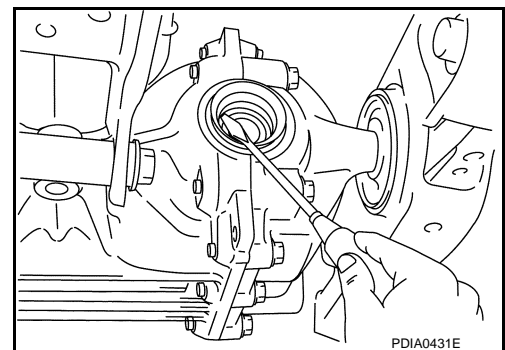

INSTALLATION

1. Install side oil seals until it becomes flush with the carrier end, using the drift (A) [SST: KV38100200 (J-26233)].

CAUTION:

- Never reuse oil seals.
- When installing, never incline oil seals.
- Apply multi-purpose grease onto oil seal lips, and gear oil onto the circumference of oil seal.

2. Install rear drive shafts. Refer to [RAX-15, "Exploded View"](#).
3. When oil leaks while removing, check oil level after the installation. Refer to [DLN-92, "Inspection"](#).

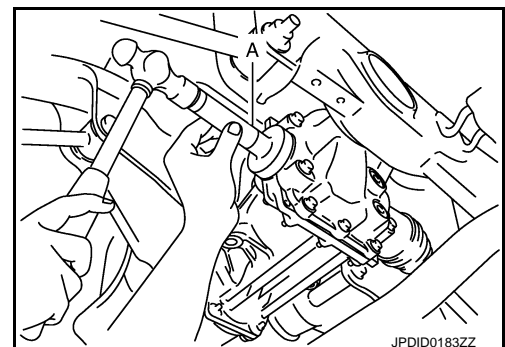

ELECTRIC CONTROLLED COUPLING

< REMOVAL AND INSTALLATION >

[REAR FINAL DRIVE: R145]

ELECTRIC CONTROLLED COUPLING

Exploded View

INFOID:000000006260450

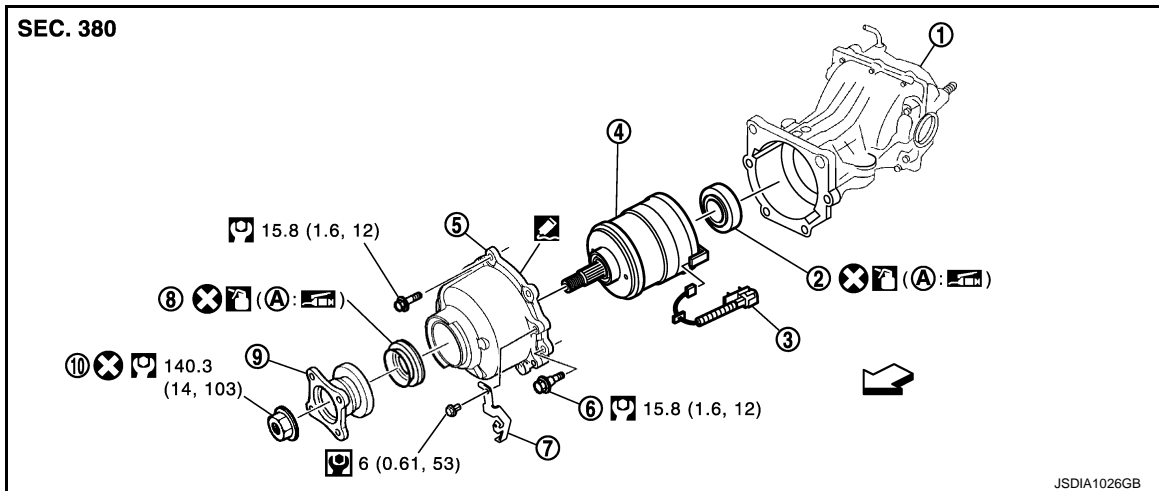

- | | | |
|----------------------------------|---------------------|-------------------------|
| 1. Final drive assembly | 2. Center oil seal* | 3. AWD solenoid harness |
| 4. Electric controlled coupling* | 5. Coupling cover | 6. Reamer bolt |
| 7. Connector bracket | 8. Front oil seal | 9. Companion flange |
| 10. Companion flange lock nut | | |
| A. Oil seal lip | | |

*: When replacing electric controlled coupling, replace center oil seal.

←: Vehicle front

: Apply gear oil.

: Apply Genuine Silicone RTV or equivalent. Refer to [GI-22, "Recommended Chemical Products and Sealants"](#).

Refer to [GI-4, "Components"](#) for symbols not described above.

Removal and Installation

INFOID:000000006260451

REMOVAL

1. Remove rear propeller shaft. Refer to [DLN-82, "Exploded View"](#).
2. Disconnect AWD solenoid harness connector.
3. Remove connector bracket.
4. Put matching mark on the thread edge of electric controlled coupling. The matching mark should be in line with the matching mark on the companion flange.

CAUTION:

For matching mark, use paint. Never damage electric controlled coupling.

NOTE:

When replacing electric controlled coupling, matching mark is not necessary.

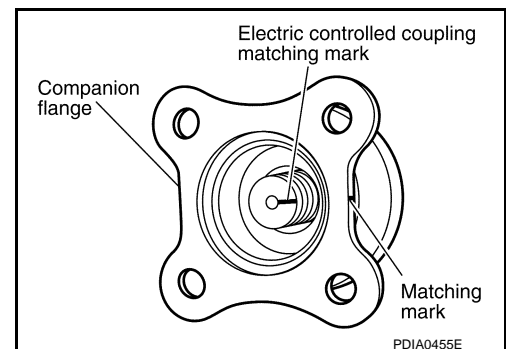

ELECTRIC CONTROLLED COUPLING

< REMOVAL AND INSTALLATION >

[REAR FINAL DRIVE: R145]

5. Remove companion flange lock nut, using a flange wrench (commercial service tool).
6. Remove companion flange.
7. Remove electric controlled coupling breather hose from coupling cover.

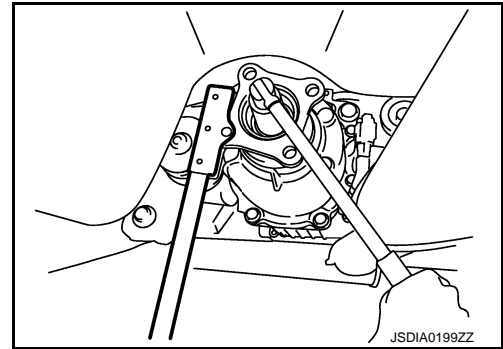

8. Remove coupling cover with electric controlled coupling from final drive assembly.
9. Remove center oil seal from final drive assembly.
CAUTION:
When removing electric controlled coupling, replace center oil seal.
10. Remove electric controlled coupling from coupling cover.
11. Remove AWD solenoid harness.

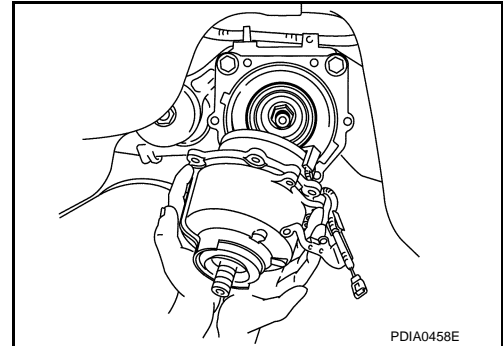

12. Remove front oil seal from coupling cover, using a suitable tool.
CAUTION:
Never damage coupling cover.

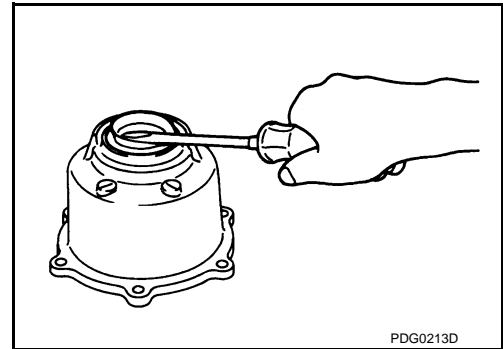

INSTALLATION

1. Using the drift (A) [SST: ST35271000 (J-26091)], install center oil seal (1) as shown in the figure.

D : 0.8 – 1.2 mm (0.031 – 0.047 in)

CAUTION:

- Never reuse oil seal.
- When installing, never incline oil seal.
- Apply multi-purpose grease onto oil seal lips, and gear oil onto the circumference of oil seal.
- The specifications of center oil seals depend on the vehicle-mounted electric controlled coupling. Therefore, when replacing only a center oil seal, measure the inner diameter of the removed center oil seal to install a new one appropriate to the electric controlled coupling. For selecting oil seal, refer to the latest parts information.

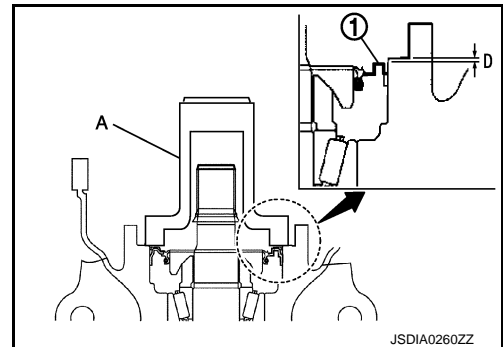

2. Connect AWD solenoid harness to electric controlled coupling.

A
B
C
DLN
E
F
G
H
I
J
K
L
M
N
O
P

ELECTRIC CONTROLLED COUPLING

< REMOVAL AND INSTALLATION >

[REAR FINAL DRIVE: R145]

3. Install electric controlled coupling to spline of drive pinion inside gear carrier.
 - CAUTION:**
 - Align the pin on electric controlled coupling with the groove of gear carrier.
 - Be careful not to damage center oil seal.
4. Set AWD solenoid harness guide to gear carrier.

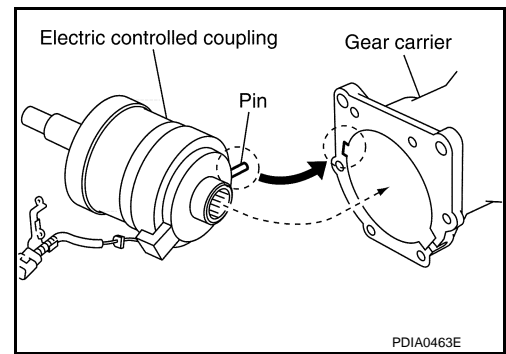

5. Using the drifts, drive front oil seal until it becomes flush with the coupling cover end.

- A : Drift [SST: KV38100200 (J-26233)]
- B : Drift [SST: ST27861000 (—)]

- CAUTION:**
 - Never reuse oil seal.
 - When installing, never incline oil seal.
 - Apply multi-purpose grease onto oil seal lips, and gear oil onto the circumference of oil seal.

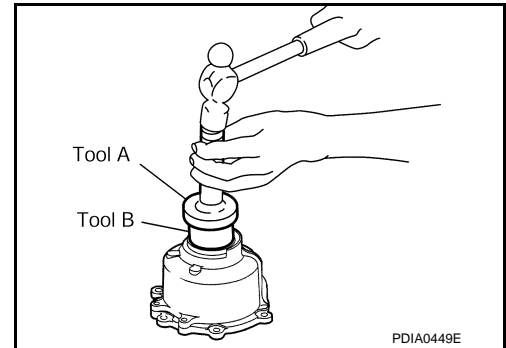

6. Apply liquid gasket to mating surface of coupling cover. Overlap both ends of the bead for at least 3 mm (0.12 in). Use Genuine Silicone RTV or equivalent. Refer to [GI-22. "Recommended Chemical Products and Sealants"](#).

- CAUTION:**
 - Remove old gasket adhering to the mounting surfaces.
 - Also remove any moisture, oil, or foreign material adhering to the mounting surfaces.

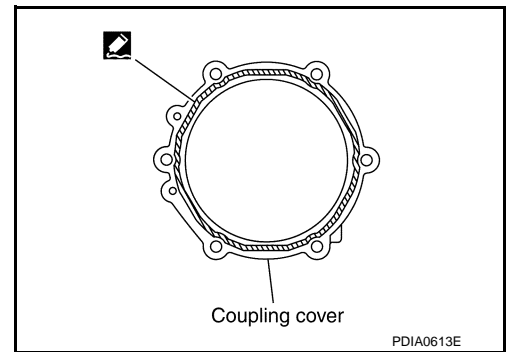

7. Install coupling cover to final drive assembly with arrow facing upward, temporarily tighten reamer bolts to the positions shown in the figure.
8. Tighten reamer bolts and coupling cover mounting bolts to the specified torque.
9. Install electric controlled coupling breather hose to coupling cover.
10. Install connector bracket, and tighten bolts to the specified torque.
11. Connect AWD solenoid harness connector.

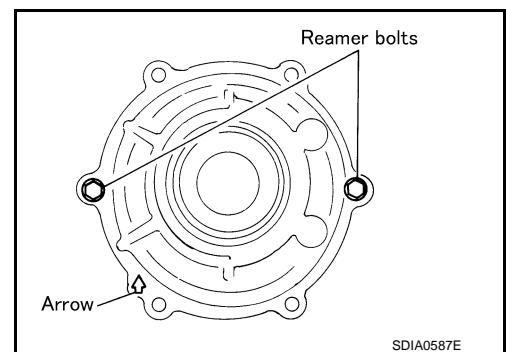

12. Install companion flange.
 - NOTE:**
 - When reusing electric controlled coupling, align the matching mark of electric controlled coupling with the matching mark of companion flange, then install companion flange.
13. Install companion flange lock nut with flange wrench (commercial service tool), tighten to the specified torque.

- CAUTION:**
 - Never reuse companion flange lock nut.

14. Check companion flange runout. Refer to [DLN-106. "Adjustment"](#).

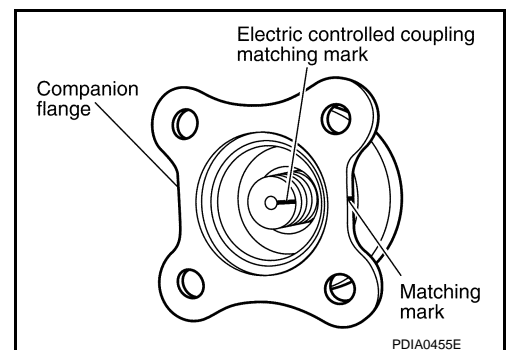

ELECTRIC CONTROLLED COUPLING

< REMOVAL AND INSTALLATION >

[REAR FINAL DRIVE: R145]

15. Install rear propeller shaft. Refer to [DLN-82, "Exploded View"](#).
16. When oil leaks while removing, check oil level after the installation. Refer to [DLN-92, "Inspection"](#).

A
B
C
DLN
E
F
G
H
I
J
K
L
M
N
O
P

REAR FINAL DRIVE ASSEMBLY

< UNIT REMOVAL AND INSTALLATION >

[REAR FINAL DRIVE: R145]

UNIT REMOVAL AND INSTALLATION

REAR FINAL DRIVE ASSEMBLY

Exploded View

INFOID:000000006260452

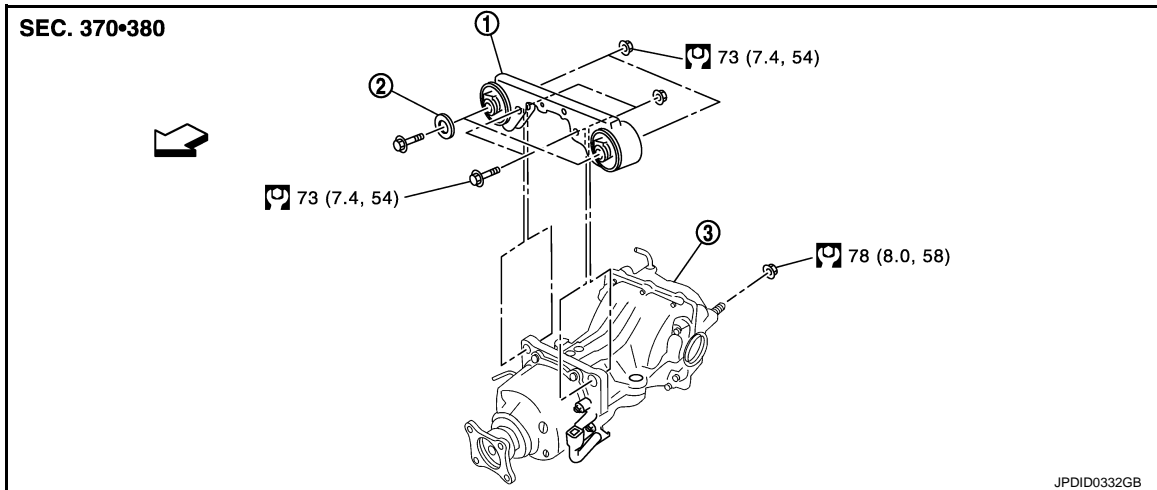

1. Final drive mounting bracket

2. Washer

3. Final drive assembly

↔: Vehicle front

Refer to [GI-4, "Components"](#) for symbols in the figure.

Removal and Installation

INFOID:000000006260453

REMOVAL

1. Remove rear propeller shaft. Refer to [DLN-82, "Exploded View"](#).
2. Remove stabilizer bar. Refer to [RSU-15, "Exploded View"](#).
3. Remove EVAP canister. Refer to [FL-15, "Exploded View"](#).
4. Disconnect rear drive shafts (final drive side). Refer to [RAX-15, "Exploded View"](#).
5. Disconnect AWD solenoid harness connector.
6. Remove rear final drive breather hose and electric controlled coupling breather hose.
7. Support final drive assembly with a suitable jack.
8. Remove rear final drive mounting nut (↔) at rear suspension member.

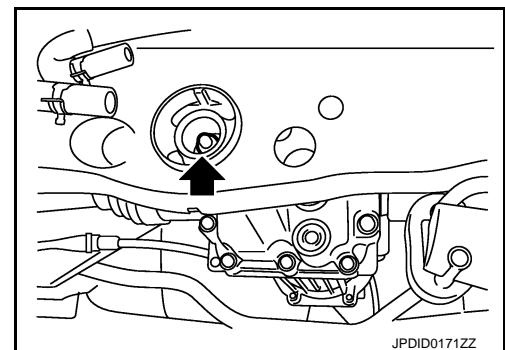

REAR FINAL DRIVE ASSEMBLY

< UNIT REMOVAL AND INSTALLATION >

[REAR FINAL DRIVE: R145]

9. Remove final drive mounting nuts and final drive mounting bolts with power tool. If necessary, remove final drive mounting bracket and washer with power tool.

CAUTION:

Secure final drive assembly to a suitable jack while removing it.

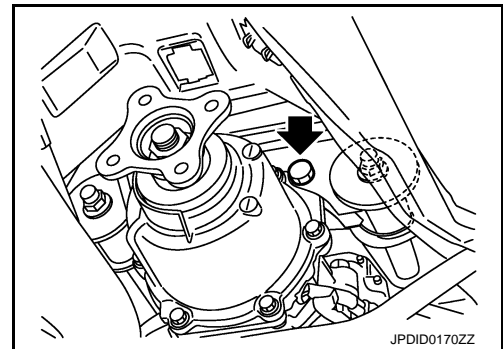

INSTALLATION

Note the following, and install in the reverse order of removal.

- Install the breather hose (1) to breather connector until dimension (A) shown as follows.

A:

Final drive side : 20 mm (0.79 in)

Suspension member side : 20.7 mm (0.815 in)

CAUTION:

- **Never reuse hose clamp.**
- **Make sure there are no pinched or restricted areas on the breather hose caused by bending or winding when installing it.**
- **Install the hose clamp at the final drive side, with the tab facing to the vehicle front.**
- **Install the hose clamp at the suspension member side, with the tab facing down ward.**
- If remove breather connector (2) and metal connector (3), install breather hose (1), breather connector and metal connector as shown in the figure.
- For installation, insert breather connector into the square hole of rear suspension. Install metal connector to rear cover with aiming painted marking to the front of vehicle.

↔ : Vehicle front

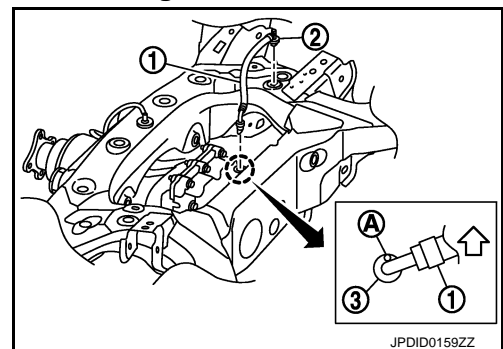
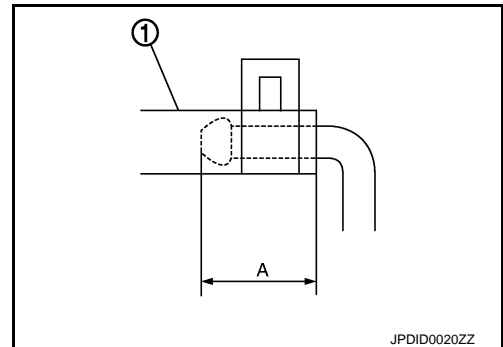

- Install the electric controlled coupling breather hose (1) as shown in the figure.
- Install electric controlled coupling breather hose at the coupling side to the metal tube (3) of the coupling cover (2) all the way to the point shown by the solid arrow (↔).

↔ : Vehicle front

- Install electric controlled coupling breather hose at the suspension member side until dimension (L) shown as follows.

L : 15 mm

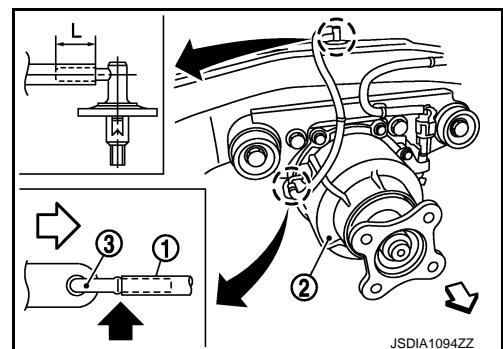

- Install the hose clip at the position 152 mm from breather hose end on the breather connector side.

CAUTION:

- **Make sure there are no pinched or restricted areas on the breather hose caused by bending or winding when installing it.**
- **Make sure that insert hose clip into the hole of final drive mounting bracket.**

A
B
C
DLN
E
F
G
H
I
J
K
L
M
N
O
P

REAR FINAL DRIVE ASSEMBLY

< UNIT REMOVAL AND INSTALLATION >

[REAR FINAL DRIVE: R145]

- If remove breather connector of the electric controlled coupling (1) and metal tube (2), install them as shown in the figure.
- Install the breather connector at the insertion side to the suspension member, facing to the vehicle front.
- Install the metal tube to the coupling cover, facing to the vehicle front.

CAUTION:

Never reuse breather connector and metal connector.

- When oil leaks while removing final drive assembly, check oil level after the installation. Refer to [DLN-92. "Inspection"](#).

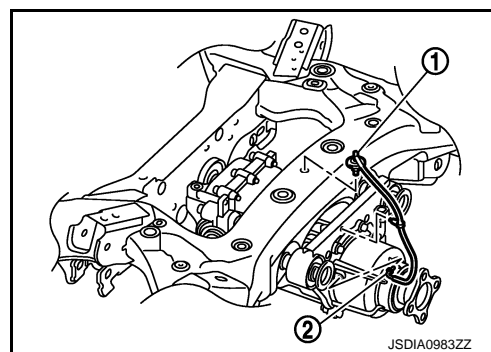

ELECTRIC CONTROLLED COUPLING

< UNIT DISASSEMBLY AND ASSEMBLY >

[REAR FINAL DRIVE: R145]

UNIT DISASSEMBLY AND ASSEMBLY

ELECTRIC CONTROLLED COUPLING

Exploded View

INFOID:000000006260454

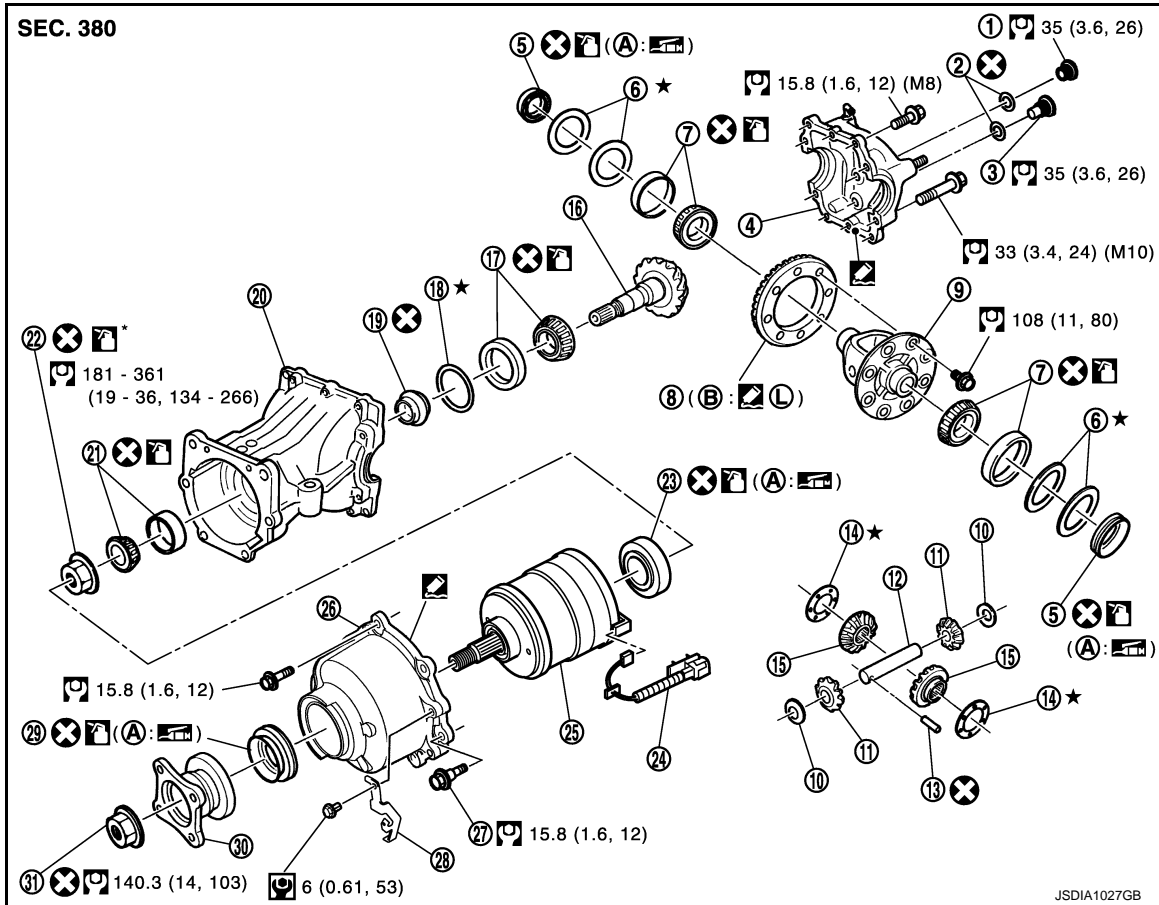

- | | | |
|-----------------------------------|-----------------------------|---------------------------------|
| 1. Filler plug | 2. Gasket | 3. Drain plug |
| 4. Rear cover | 5. Side oil seal | 6. Side bearing adjusting shim |
| 7. Side bearing | 8. Drive gear | 9. Differential case |
| 10. Pinion mate thrust washer | 11. Pinion mate gear | 12. Pinion mate shaft |
| 13. Lock pin | 14. Side gear thrust washer | 15. Side gear |
| 16. Drive pinion | 17. Pinion rear bearing | 18. Drive pinion adjusting shim |
| 19. Collapsible spacer | 20. Gear carrier | 21. Pinion front bearing |
| 22. Drive pinion nut | 23. Center oil seal* | 24. AWD solenoid harness |
| 25. Electric controlled coupling* | 26. Coupling cover | 27. Reamer bolt |
| 28. Connector bracket | 29. Front oil seal | 30. Companion flange |
| 31. Companion flange lock nut | | |

A. Oil seal lip B. Screw hole

*: When replacing electric controlled coupling, replace center oil seal.

: Apply gear oil.

*: Apply anti-corrosive oil.

: Apply Genuine Silicone RTV or equivalent. Refer to [GI-22. "Recommended Chemical Products and Sealants"](#).

ELECTRIC CONTROLLED COUPLING

< UNIT DISASSEMBLY AND ASSEMBLY >

[REAR FINAL DRIVE: R145]

: Apply Genuine Medium Strength Thread Locking Sealant or equivalent. Refer to [GI-22. "Recommended Chemical Products and Sealants"](#).

Refer to [GI-4. "Components"](#) for symbols not described above.

Disassembly

INFOID:000000006260455

1. Remove connector bracket.
2. Put matching mark on the thread edge of electric controlled coupling. The matching mark should be in line with the matching mark on companion flange.

CAUTION:

For matching mark, use paint. Never damage electric controlled coupling.

NOTE:

When replacing electric controlled coupling, matching mark is not necessary.

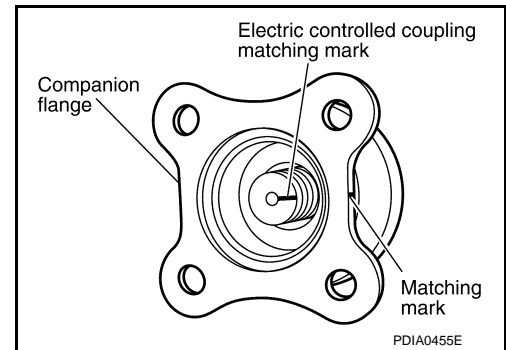

3. Remove companion flange lock nut, using a flange wrench (commercial service tool).
4. Remove companion flange.
5. Remove coupling cover.

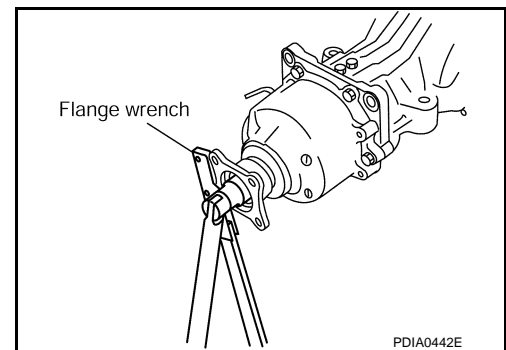

6. Remove front oil seal from coupling cover, using a suitable tool.

CAUTION:

Never damage coupling cover.

7. Remove electric controlled coupling.
8. Remove center oil seal from gear carrier.

CAUTION:

When removing electric controlled coupling, replace center oil seal.

9. Remove AWD solenoid harness.

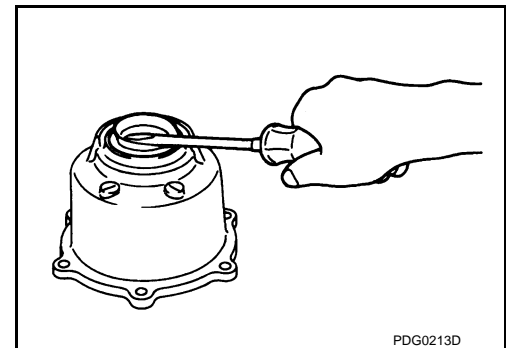

Assembly

INFOID:000000006260456

1. Using the drift (A) [SST: ST35271000 (J-26091)], install center oil seal (1) as shown in the figure.

D : 0.8 – 1.2 mm (0.031 – 0.047 in)

CAUTION:

- Never reuse oil seal.
- When installing, never incline oil seal.
- Apply multi-purpose grease onto oil seal lips, and gear oil onto the circumference of oil seal.
- The specifications of center oil seals depend on the vehicle-mounted electric controlled coupling. Therefore, when replacing only a center oil seal, measure the inner diame-

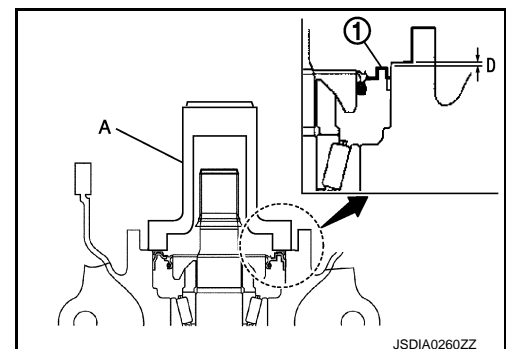

ELECTRIC CONTROLLED COUPLING

< UNIT DISASSEMBLY AND ASSEMBLY >

[REAR FINAL DRIVE: R145]

ter of the removed center oil seal to install a new one appropriate to the electric controlled coupling. For selecting oil seal, refer to the latest parts information.

2. Connect AWD solenoid harness to electric controlled coupling.
3. Install electric controlled coupling to spline of drive pinion inside gear carrier.
CAUTION:
 - Align the pin on electric controlled coupling with the groove of gear carrier.
 - Be careful not to damage center oil seal.
4. Set AWD solenoid harness guide to gear carrier.

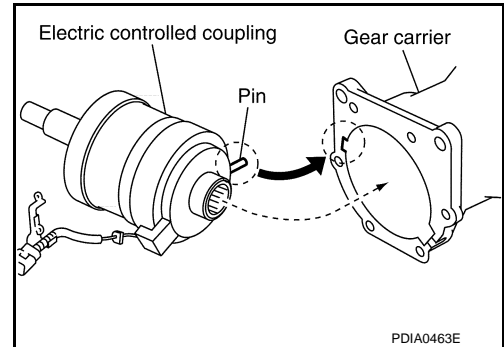

5. Using the drifts, drive front oil seal until it becomes flush with the coupling cover end.

A : Drift [SST: KV38100200 (J-26233)]

B : Drift [SST: ST27861000 (—)]

CAUTION:

- Never reuse oil seal.
- When installing, never incline oil seal.
- Apply multi-purpose grease onto oil seal lips, and gear oil onto the circumference of oil seal.

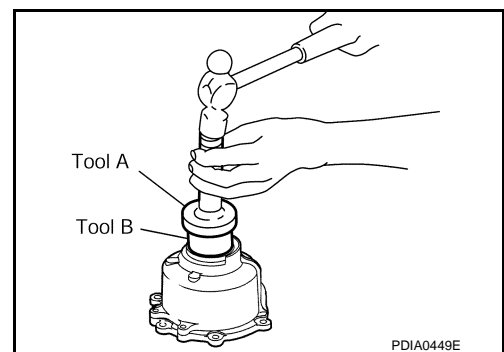

6. Apply liquid gasket to mating surface of coupling cover. Overlap both ends of the bead for at least 3 mm (0.12 in). Use Genuine Silicone RTV or equivalent. Refer to [GI-22. "Recommended Chemical Products and Sealants"](#).

CAUTION:

Remove old gasket adhering to the mounting surfaces. Also remove any moisture, oil, or foreign material adhering to the mounting surfaces.

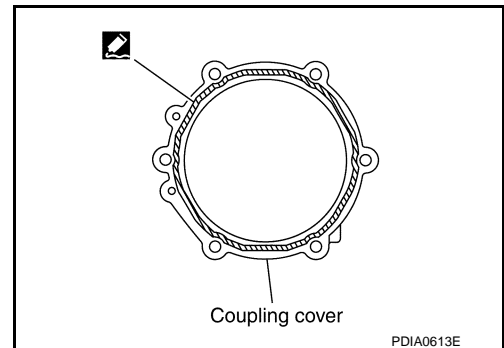

7. Install coupling cover to gear carrier with arrow facing upward, temporarily tighten reamer bolts to the positions shown in the figure.
8. Tighten reamer bolts and coupling cover mounting bolts to the specified torque.
9. Install connector bracket, and tighten bolts to the specified torque.

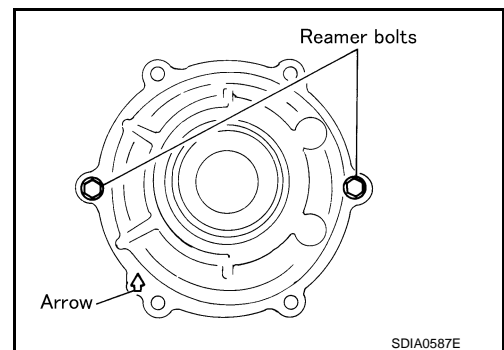

ELECTRIC CONTROLLED COUPLING

< UNIT DISASSEMBLY AND ASSEMBLY >

[REAR FINAL DRIVE: R145]

10. Install companion flange.

NOTE:

When reusing electric controlled coupling, align the matching mark of electric controlled coupling with the matching mark of companion flange, then install companion flange.

11. Install companion flange lock nut with flange wrench (commercial service tool), tighten to the specified torque.

CAUTION:

Never reuse companion flange lock nut.

12. Check companion flange runout. Refer to [DLN-106. "Adjustment"](#).

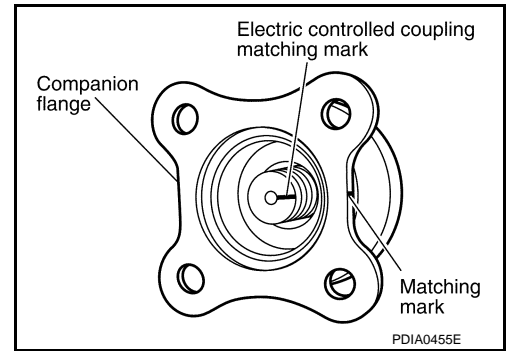

INFOID:000000006260457

Adjustment

COMPANION FLANGE RUNOUT

1. Fit a dial indicator onto the companion flange face (inner side of the rear propeller shaft mounting bolt holes).
2. Rotate companion flange to check for runout.

Limit

Companion flange runout : Refer to [DLN-125. "Companion Flange Runout"](#).

3. Fit a test indicator to the inner side of companion flange (socket diameter).
4. Rotate companion flange to check for runout.

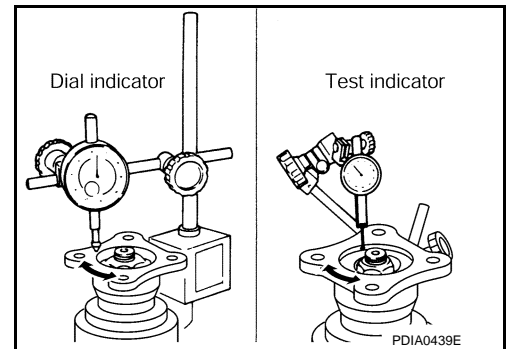

Limit

Companion flange runout : Refer to [DLN-125. "Companion Flange Runout"](#).

5. If the runout value is outside the runout limit, follow the procedure below to adjust.
 - a. Check for runout while changing the phase between companion flange and drive pinion by 90° step, and search for the position where the runout is the minimum.
 - b. If the runout value is still outside of the limit after the phase has been changed, replace companion flange.
 - c. If the runout value is still outside of the limit after companion flange has been replaced, possible cause will be an assembly malfunction of drive pinion and electric controlled coupling, malfunctioning coupling bearing, or malfunctioning of electric controlled coupling.

Inspection After Disassembly

INFOID:000000006260458

DRIVE GEAR AND DRIVE PINION

- Clean up the disassembled parts.
- If the gear teeth never mesh or line-up correctly, determine the cause and adjust or replace as necessary.
- If the gears are worn, cracked, damaged, pitted or chipped (by friction) noticeably, replace with new drive gear and drive pinion as a set.

BEARING

- Clean up the disassembled parts.
- If any chipped (by friction), pitted, worn, rusted or scratched marks, or unusual noise from the bearing is observed, replace as a bearing assembly (as a new set).

SIDE GEAR AND PINION MATE GEAR

- Clean up the disassembled parts.
- If any cracks or damage on the surface of the tooth is found, replace.
- If any worn or chipped mark on the contact sides of the thrust washer is found, replace.

SIDE GEAR THRUST WASHER AND PINION MATE THRUST WASHER

- Clean up the disassembled parts.

ELECTRIC CONTROLLED COUPLING

< UNIT DISASSEMBLY AND ASSEMBLY >

[REAR FINAL DRIVE: R145]

- If it is chipped (by friction), damaged, or unusually worn, replace.

OIL SEAL

- Whenever disassembled, replace.
- If wear, deterioration of adherence (sealing force lips), or damage is detected on the lips, replace them.

DIFFERENTIAL CASE

- Clean up the disassembled parts.
- If any wear or crack on the contact sides of the differential case is found, replace.

COMPANION FLANGE

- Clean up the disassembled parts.
- If any chipped mark [about 0.1 mm, (0.004 in)] or other damage on the contact sides of the lips of the companion flange is found, replace.

A

B

C

DLN

E

F

G

H

I

J

K

L

M

N

O

P

DIFFERENTIAL ASSEMBLY

< UNIT DISASSEMBLY AND ASSEMBLY >

[REAR FINAL DRIVE: R145]

DIFFERENTIAL ASSEMBLY

Exploded View

INFOID:000000006260459

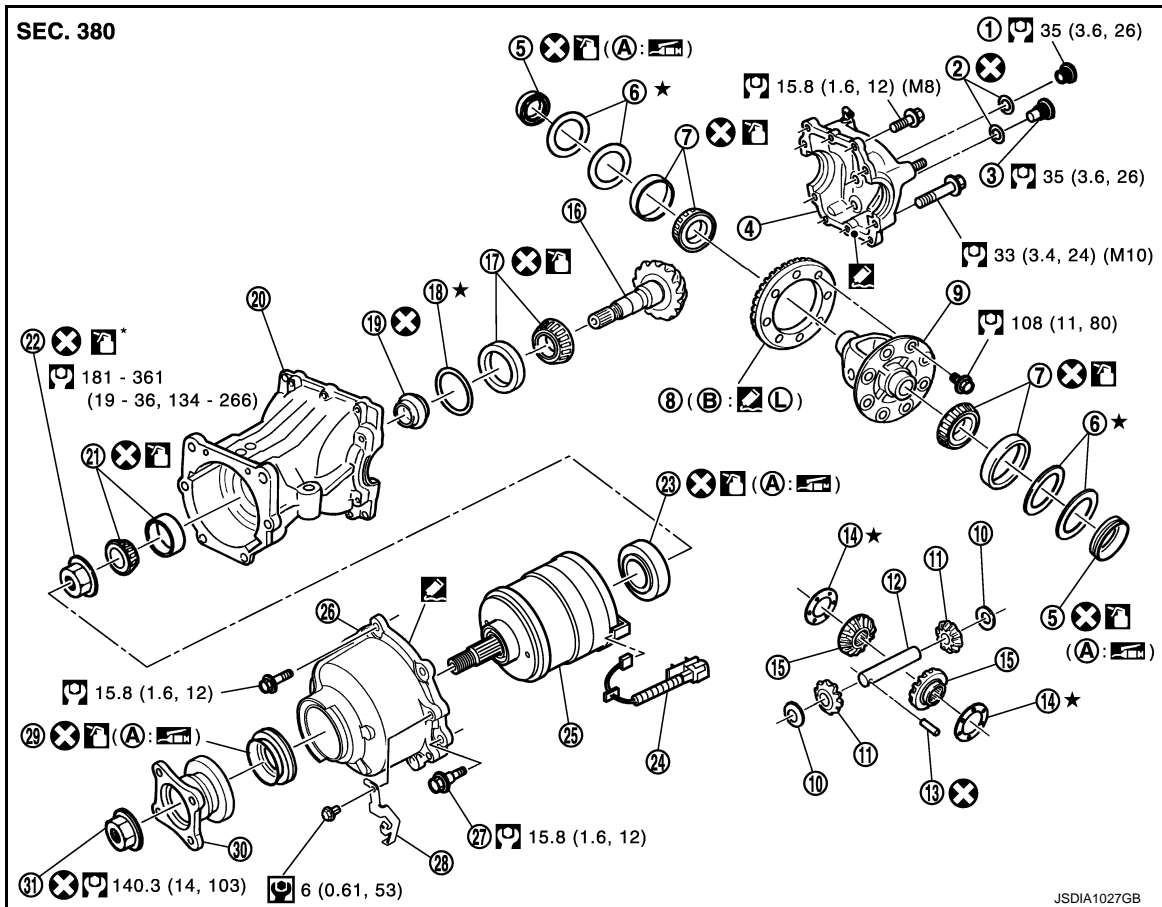

- | | | |
|-----------------------------------|-----------------------------|---------------------------------|
| 1. Filler plug | 2. Gasket | 3. Drain plug |
| 4. Rear cover | 5. Side oil seal | 6. Side bearing adjusting shim |
| 7. Side bearing | 8. Drive gear | 9. Differential case |
| 10. Pinion mate thrust washer | 11. Pinion mate gear | 12. Pinion mate shaft |
| 13. Lock pin | 14. Side gear thrust washer | 15. Side gear |
| 16. Drive pinion | 17. Pinion rear bearing | 18. Drive pinion adjusting shim |
| 19. Collapsible spacer | 20. Gear carrier | 21. Pinion front bearing |
| 22. Drive pinion nut | 23. Center oil seal* | 24. AWD solenoid harness |
| 25. Electric controlled coupling* | 26. Coupling cover | 27. Reamer bolt |
| 28. Connector bracket | 29. Front oil seal | 30. Companion flange |
| 31. Companion flange lock nut | | |

A. Oil seal lip B. Screw hole

*: When replacing electric controlled coupling, replace center oil seal.

: Apply gear oil.

: Apply anti-corrosive oil.

: Apply Genuine Silicone RTV or equivalent. Refer to [GI-22, "Recommended Chemical Products and Sealants"](#).

: Apply Genuine Medium Strength Thread Locking Sealant or equivalent. Refer to [GI-22, "Recommended Chemical Products and Sealants"](#).

Refer to [GI-4, "Components"](#) for symbols not described above.

DIFFERENTIAL ASSEMBLY

< UNIT DISASSEMBLY AND ASSEMBLY >

[REAR FINAL DRIVE: R145]

Disassembly

INFOID:000000006260460

1. Remove side oil seals, using a suitable tool.
CAUTION:
Be careful not to damage gear carrier and rear cover.
2. Remove rear cover mounting bolts.

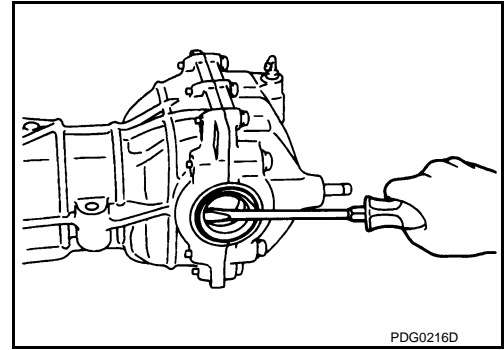

3. Set drifts [SST: KV40100610 (J-26089)] to the right and left side bearing adjusting shims individually. Press differential case assembly with side bearing to remove gear carrier assembly and rear cover assembly.

CAUTION:

The pressure shall be as low as possible to remove gear carrier assembly and rear cover assembly. The maximum pressure shall be 10 kN (1 ton, 1.1 US ton, 1.0 Imp ton).

NOTE:

Differential case assembly, side bearings, and adjusting shims are compressed and integrated in gear carrier and rear cover.

4. Remove drain plug and filler plug.
5. Remove side bearing adjusting shims and side bearing outer races.

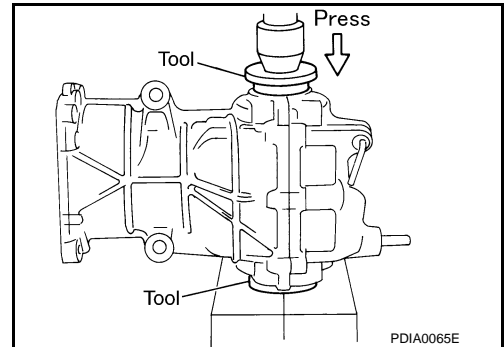

CAUTION:

Mark the side bearing adjusting shims so that the original mounting positions (right/left) can be identified later.

6. Remove drive gear mounting bolts and then remove drive gear from differential case.

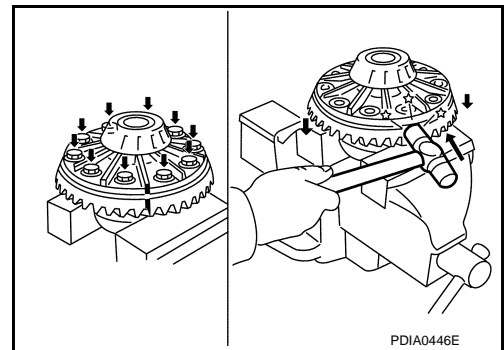

7. Remove side bearing inner races, using pullers and the drift [SST: ST33052000 (—)].

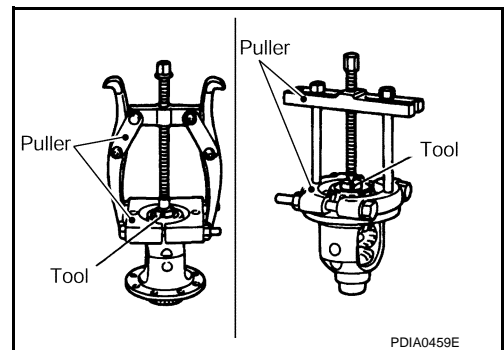

A
B
C
DLN
E
F
G
H
I
J
K
L
M
N
O
P

DIFFERENTIAL ASSEMBLY

< UNIT DISASSEMBLY AND ASSEMBLY >

[REAR FINAL DRIVE: R145]

8. Pull the lock pin out of pinion mate shaft, using the pin punch.

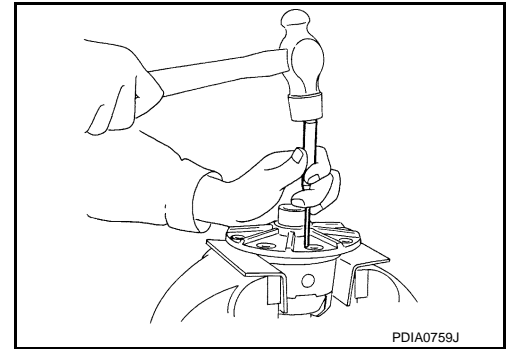

9. Remove pinion mate shaft, pinion mate gears, pinion mate thrust washers, side gears, side gear thrust washers from differential case.

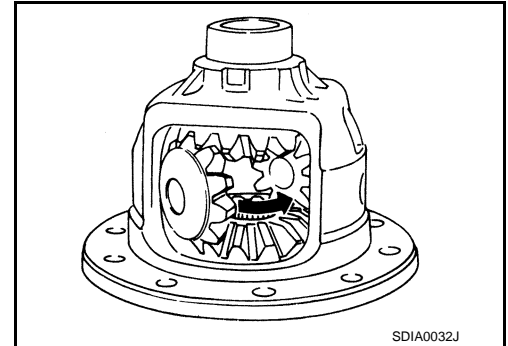

INFOID:000000006260461

Assembly

1. Install new side gear thrust washers with the same thickness as the ones installed prior to disassembly or reinstall the old ones on the side gears.
2. Install side gears and side gear thrust washers into differential case.

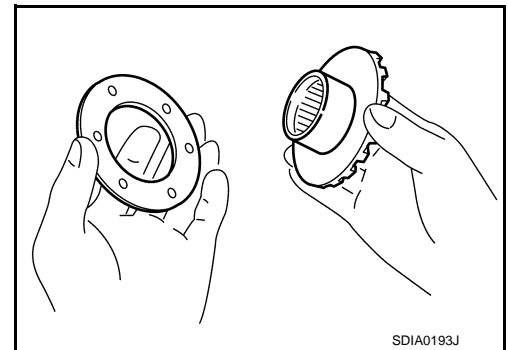

3. Align 2 pinion mate gears in diagonally opposite positions, then rotate and install them into differential case after installing pinion mate thrust washers to pinion mate gears.

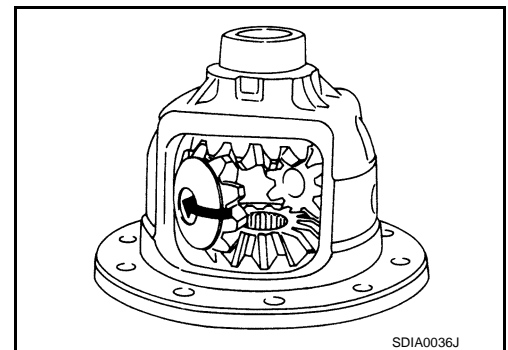

DIFFERENTIAL ASSEMBLY

< UNIT DISASSEMBLY AND ASSEMBLY >

[REAR FINAL DRIVE: R145]

4. Align the lock pin holes on differential case with shaft, and install pinion mate shaft.

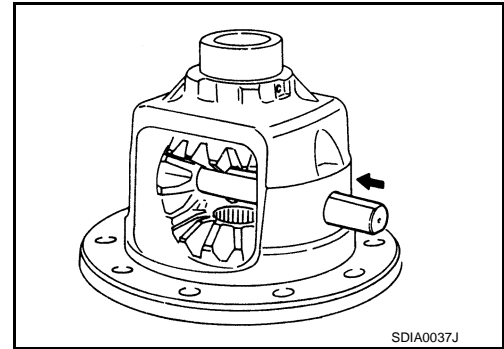

5. Measure side gear end play following the procedure below, and select the appropriate side gear thrust washers.
 - a. Place differential case straight up so that side gear to be measured comes upward.

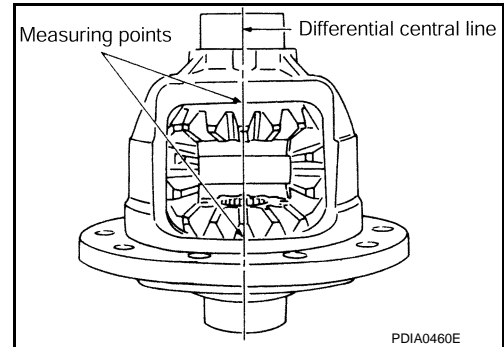

- b. Using thickness gauges, measure the clearance between side gear back and differential case at 3 different positions, while rotating side gear. Average the 3 readings, and then decide the clearance. (Measure the clearance of the other side as well.)

Standard

Side gear back clearance : Refer to [DLN-125, "Differential Side Gear Clearance"](#).

CAUTION:

To prevent side gear from tilting, insert thickness gauges with the same thickness from both sides.

- c. If the back clearance is outside the specification, use a thicker/thinner side gear thrust washer to adjust.

When the back clearance is large:

Use a thicker thrust washer.

When the back clearance is small:

Use a thinner thrust washer.

CAUTION:

Select a side gear thrust washer for right and left individually.

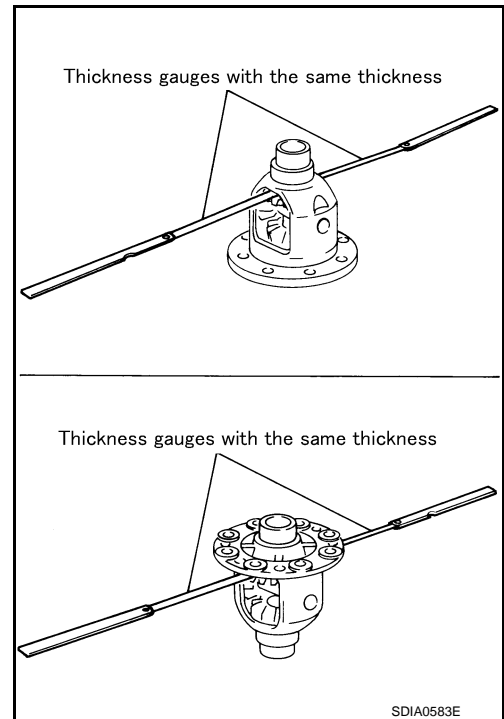

A
B
C
DLN
E
F
G
H
I
J
K
L
M
N
O
P

DIFFERENTIAL ASSEMBLY

< UNIT DISASSEMBLY AND ASSEMBLY >

[REAR FINAL DRIVE: R145]

6. Drive a lock pin into pinion mate shaft, using the pin punch.

CAUTION:
Never reuse lock pin.

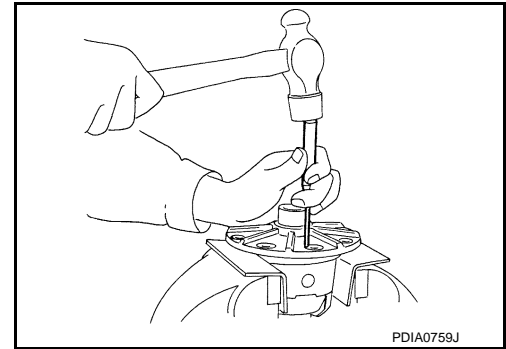

7. Press side bearing inner races to differential case, using the drift [SST: KV40105020 (—)].

CAUTION:
Never reuse side bearing inner races.

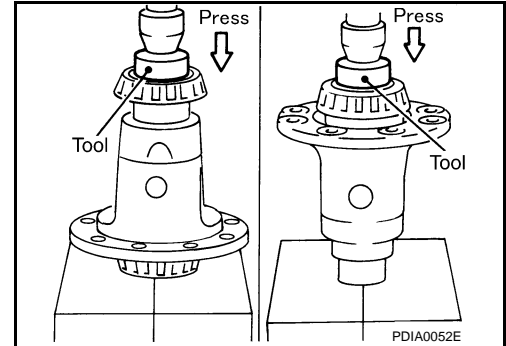

8. Apply locking sealant into the thread hole of drive gear. Use Genuine Medium Strength Thread Locking Sealant or equivalent. Refer to [GI-22. "Recommended Chemical Products and Sealants"](#).

CAUTION:
The drive gear back and threaded holes shall be cleaned and decreased sufficiently.

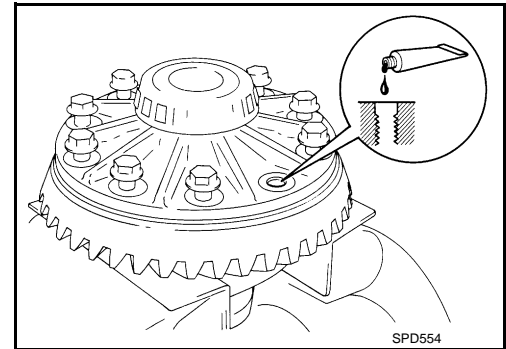

9. Install drive gear to the differential case, and then tighten to the specified torque.

10. Apply gear oil to side bearings, and install new side bearing adjusting shims (2 pieces for one side) with the same thickness as the ones installed prior to disassembly or re-install the old ones, with side bearing outer race to differential case. If side bearing adjusting shims have been already selected, use them.

CAUTION:
Never reuse side bearing outer race.

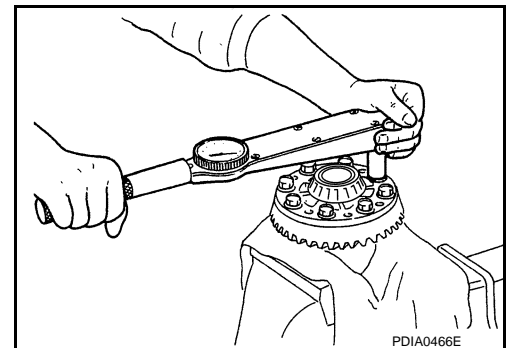

11. Set the drifts [SST: KV40100610 (J-26089)] to the right and left side bearing adjusting shims individually. Compress differential case assembly and side bearing to install gear carrier assembly to differential case assembly.

CAUTION:

- The drift shall be placed on the center of the adjusting shims.
- The pressure shall be as low as possible to install differential assembly into gear carrier assembly. The maximum pressure shall be 10 kN (1 ton, 1.1 US ton, 1.0 Imp ton).
- If the adjusting shims are installed by tapping, the gear carrier may be damaged. Avoid tapping.

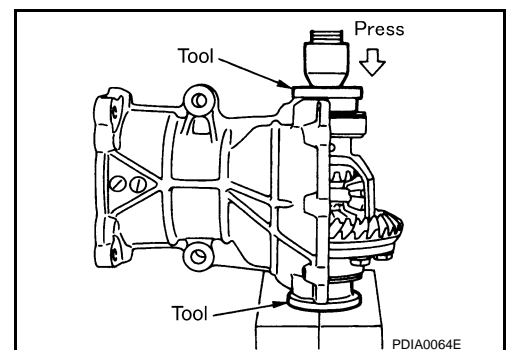

DIFFERENTIAL ASSEMBLY

< UNIT DISASSEMBLY AND ASSEMBLY >

[REAR FINAL DRIVE: R145]

12. Install dummy cover set, check and adjust drive gear runout, tooth contact, backlash, and total preload torque. Refer to [DLN-120, "Adjustment"](#).
13. Remove dummy cover set.
14. Apply liquid gasket to mating surface of rear cover. Overlap both ends of the bead for at least 3 mm (0.12 in). Use Genuine Silicone RTV or equivalent. Refer to [GI-22, "Recommended Chemical Products and Sealants"](#).

CAUTION:

Remove old gasket adhering to the mounting surfaces. Also remove any moisture, oil, or foreign material adhering to the mounting surfaces.

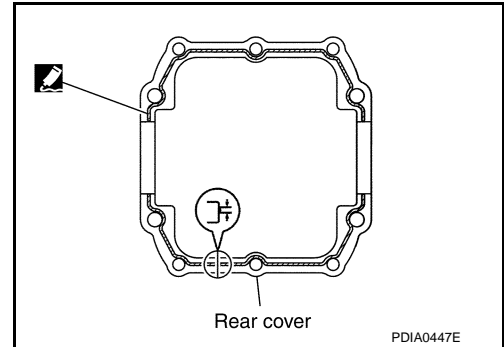

15. Set the drifts [SST: KV40100610 (J-26089)] to the right and left side bearing adjusting shims individually. Compress differential case assembly and side bearing to install rear cover.

CAUTION:

- The drift shall be placed on the center of the adjusting shims.
- The pressure shall be as low as possible to install the rear cover. The maximum pressure shall be 10 kN (1 ton, 1.0 Imp ton).
- If rear cover is forced in by tapping, rear cover may be damaged by adjusting shims. Avoid tapping.

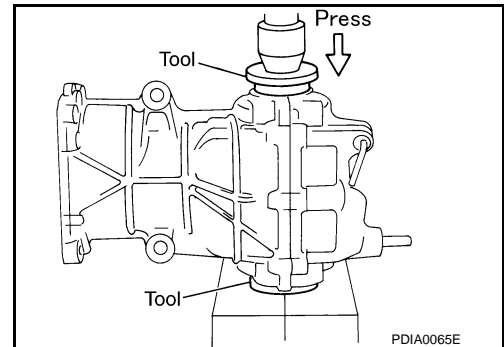

16. Tighten rear cover mounting bolts to the specified torque.
17. Using the drift [SST: KV38100200 (J-26233)], drive side oil seals until it becomes flush with the carrier end.

CAUTION:

- Never reuse oil seals.
- When installing, do not incline oil seals.
- Apply multi-purpose grease onto oil seal lips, and gear oil onto the circumference of oil seal.

18. Check total preload torque. Refer to [DLN-120, "Adjustment"](#).

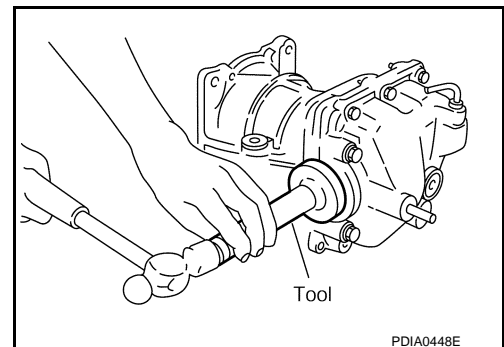

Inspection After Disassembly

INFOID:000000006260462

DRIVE GEAR AND DRIVE PINION

- Clean up the disassembled parts.
- If the gear teeth never mesh or line-up correctly, determine the cause and adjust or replace as necessary.
- If the gears are worn, cracked, damaged, pitted or chipped (by friction) noticeably, replace with new drive gear and drive pinion as a set.

BEARING

- Clean up the disassembled parts.
- If any chipped (by friction), pitted, worn, rusted or scratched marks, or unusual noise from the bearing is observed, replace as a bearing assembly (as a new set).

SIDE GEAR AND PINION MATE GEAR

- Clean up the disassembled parts.
- If any cracks or damage on the surface of the tooth is found, replace.
- If any worn or chipped mark on the contact sides of the thrust washer is found, replace.

SIDE GEAR THRUST WASHER AND PINION MATE THRUST WASHER

- Clean up the disassembled parts.
- If it is chipped (by friction), damaged, or unusually worn, replace.

A
B
C
DLN
E
F
G
H
I
J
K
L

DIFFERENTIAL ASSEMBLY

< UNIT DISASSEMBLY AND ASSEMBLY >

[REAR FINAL DRIVE: R145]

OIL SEAL

- Whenever disassembled, replace.
- If wear, deterioration of adherence (sealing force lips), or damage is detected on the lips, replace them.

DIFFERENTIAL CASE

- Clean up the disassembled parts.
- If any wear or crack on the contact sides of the differential case is found, replace.

COMPANION FLANGE

- Clean up the disassembled parts.
- If any chipped mark [about 0.1 mm, (0.004 in)] or other damage on the contact sides of the lips of the companion flange is found, replace.

DRIVE PINION

< UNIT DISASSEMBLY AND ASSEMBLY >

[REAR FINAL DRIVE: R145]

DRIVE PINION

Exploded View

INFOID:000000006260463

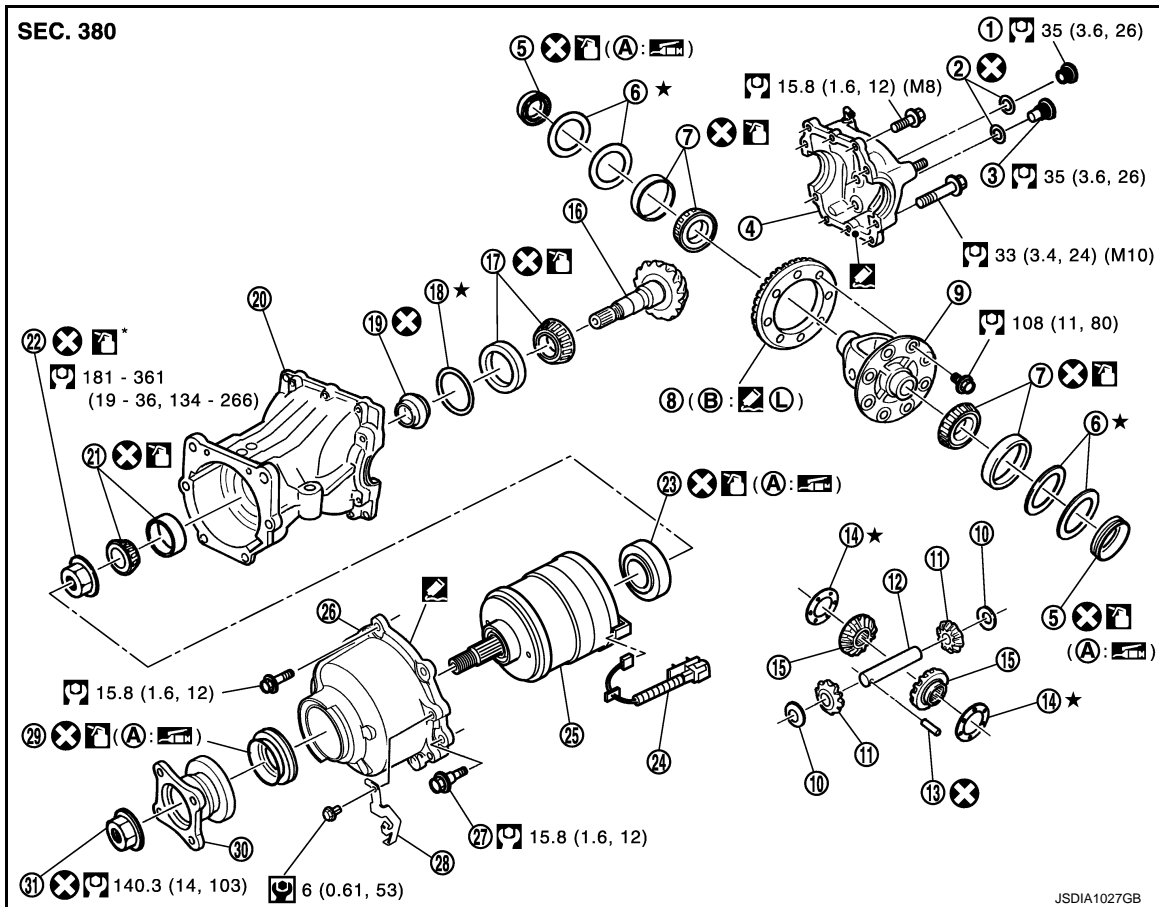

- | | | |
|-----------------------------------|-----------------------------|---------------------------------|
| 1. Filler plug | 2. Gasket | 3. Drain plug |
| 4. Rear cover | 5. Side oil seal | 6. Side bearing adjusting shim |
| 7. Side bearing | 8. Drive gear | 9. Differential case |
| 10. Pinion mate thrust washer | 11. Pinion mate gear | 12. Pinion mate shaft |
| 13. Lock pin | 14. Side gear thrust washer | 15. Side gear |
| 16. Drive pinion | 17. Pinion rear bearing | 18. Drive pinion adjusting shim |
| 19. Collapsible spacer | 20. Gear carrier | 21. Pinion front bearing |
| 22. Drive pinion nut | 23. Center oil seal* | 24. AWD solenoid harness |
| 25. Electric controlled coupling* | 26. Coupling cover | 27. Reamer bolt |
| 28. Connector bracket | 29. Front oil seal | 30. Companion flange |
| 31. Companion flange lock nut | | |

A. Oil seal lip B. Screw hole

*: When replacing electric controlled coupling, replace center oil seal.

: Apply gear oil.

: Apply anti-corrosive oil.

: Apply Genuine Silicone RTV or equivalent. Refer to [GI-22. "Recommended Chemical Products and Sealants"](#).

: Apply Genuine Medium Strength Thread Locking Sealant or equivalent. Refer to [GI-22. "Recommended Chemical Products and Sealants"](#).

Refer to [GI-4. "Components"](#) for symbols not described above.

DRIVE PINION

< UNIT DISASSEMBLY AND ASSEMBLY >

[REAR FINAL DRIVE: R145]

INFOID:00000006260464

Disassembly

1. Remove electric controlled coupling assembly. Refer to [DLN-104, "Disassembly"](#).
2. Remove differential case assembly. Refer to [DLN-109, "Disassembly"](#).
3. Fit drive pinion socket (A) onto drive pinion spline. Remove drive pinion nut, using the pinion nut wrench (B).

- A : Drive pinion socket [SST: KV38109500 (—)]
B : Pinion nut wrench [SST: KV38109400 (—)]

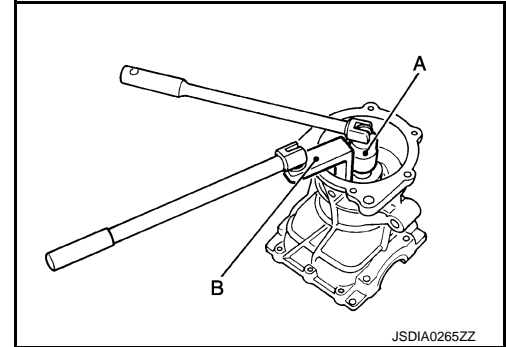

4. Press drive pinion assembly out of gear carrier.

CAUTION:

Never drop drive pinion assembly.

5. Remove pinion front bearing inner race.
6. Remove collapsible spacer.

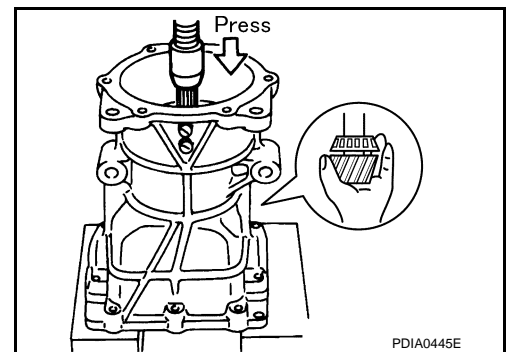

7. Remove pinion rear bearing inner race from drive pinion, using puller and bearing puller.

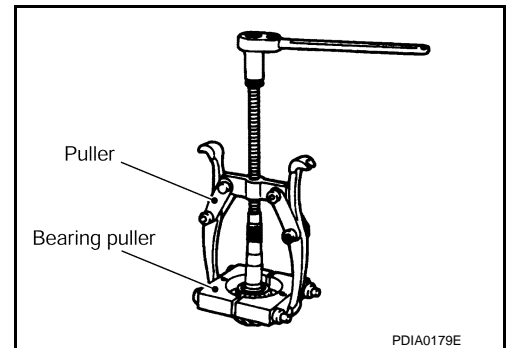

8. Using a brass rod, tap pinion front bearing outer race evenly from the 2 cutouts on gear carrier and remove pinion front bearing outer race.

CAUTION:

Be careful not to damage gear carrier.

9. Using a brass rod, tap drive pinion adjusting shim evenly from the 2 cutouts on gear carrier and remove drive pinion adjusting shim and pinion rear bearing outer race.

CAUTION:

Be careful not to damage the gear carrier.

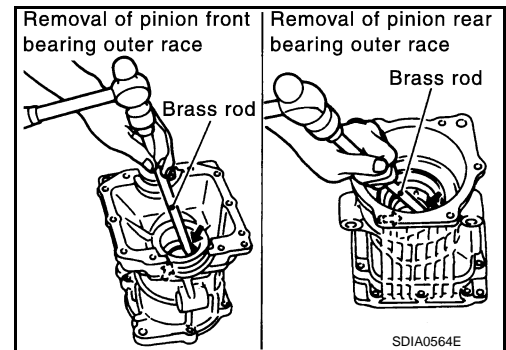

DRIVE PINION

< UNIT DISASSEMBLY AND ASSEMBLY >

[REAR FINAL DRIVE: R145]

INFOID:000000006260465

Assembly

1. Install a drive pinion adjusting shim of the same thickness as was installed prior to disassembly. Press pinion rear bearing outer race into gear carrier, using the drift [SST: ST1713000 (—)].

CAUTION:

- At first, using a hammer, tap bearing outer race until it becomes flush to gear carrier.
- Never reuse pinion rear bearing outer race.

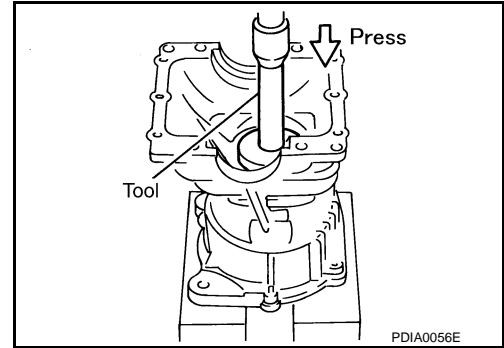

2. Press pinion front bearing outer race into gear carrier, using the drift [SST: ST33230000 (J-25805-01)].

CAUTION:

- At first, using a hammer, tap bearing outer race until it becomes flush to gear carrier.
- Never reuse pinion front bearing outer race.

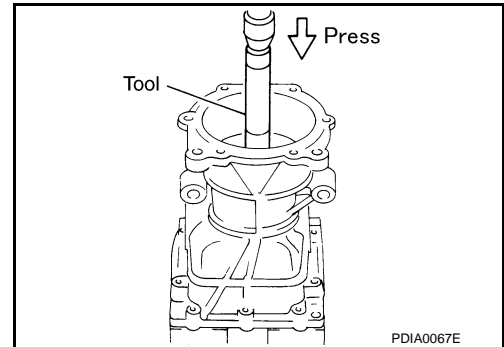

3. Press pinion rear bearing inner race to drive pinion, using the drift [SST: ST23860000 (—)].

CAUTION:

- Never reuse pinion rear bearing inner race.

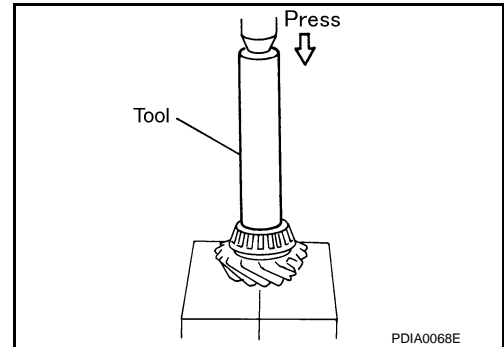

4. After checking and adjusting the tooth contact and backlash of the drive gear and drive pinion following the procedure below.

- a. Apply gear oil to the pinion rear bearing, and assemble the drive pinion to the gear carrier.

CAUTION:

- Never assemble a collapsible spacer.

- b. Apply gear oil to pinion front bearing, and assemble pinion front bearing inner race to drive pinion. Using the drifts and stand, press pinion front bearing inner race to drive pinion as far as drive pinion nut can be tightened.

A : Drift [SST: KV40100610 (J-26089)]

B : Drift [SST: ST38220000 (—)]

C : Drift [SST: ST23860000 (—)]

CAUTION:

- Never reuse pinion front bearing inner race.

- c. Temporarily tighten removed drive pinion nut to drive pinion.

NOTE:

- Use removed drive pinion nut only for the preload measurement.

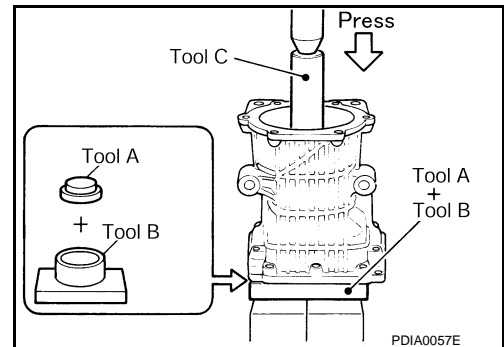

A
B
C
DLN
E
F
G
H
I
J
K
L
M
N
O
P

DRIVE PINION

< UNIT DISASSEMBLY AND ASSEMBLY >

[REAR FINAL DRIVE: R145]

- d. Fit the drive pinion socket onto the drive pinion spline. Using the pinion nut wrench, tighten drive pinion nut to the specified preload torque.

- A : Drive pinion socket [SST: KV38109500 (—)]
- B : Pinion nut wrench [SST: KV38109400 (—)]
- C : Preload gauge [SST: ST3127S000 (J-25765-A)]

Standard

Pinion bearing preload : Refer to [DLN-125, "Preload Torque"](#).

CAUTION:

Drive pinion nut is tightened with no collapsible spacer. Be careful not to overtighten it. While measuring the preload, tighten it by 5° to 10°.

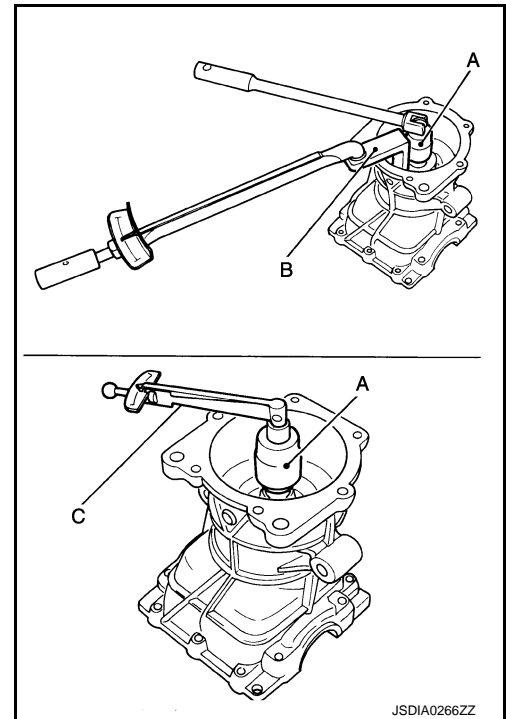

- e. Apply gear oil to side bearings, and install new side bearing adjusting shims with the same thickness or re-install the old ones to the same mounting position they were in prior to disassembly. Set the drifts [SST: KV40100610 (J-26089)] to the right and left. Install differential case assembly to gear carrier.

CAUTION:

- The drifts shall be placed on the center of the adjusting shims.
- The pressure shall be as low as possible to install gear carrier assembly to differential assembly. The maximum pressure shall be 10 kN (1 ton, 1.1 US ton, 1.0 Imp ton).
- If adjusting shims are installed by tapping, gear carrier may be damaged. Avoid tapping.

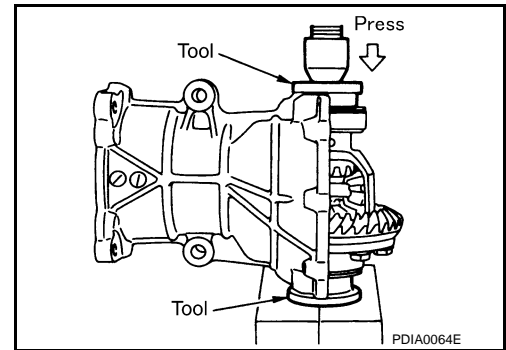

- f. Check and adjust the tooth contact. Refer to [DLN-120, "Adjustment"](#).
 g. Check and adjust the backlash. Refer to [DLN-120, "Adjustment"](#).
 h. Remove dummy cover set, and remove differential case assembly.

- i. Remove drive pinion nut and press drive pinion assembly out of gear carrier.

CAUTION:

Never drop drive pinion assembly.

- j. Remove pinion front bearing inner race.

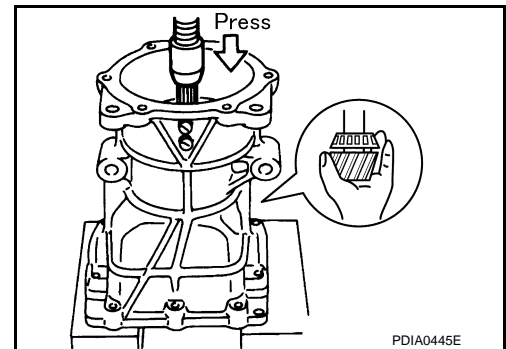

DRIVE PINION

< UNIT DISASSEMBLY AND ASSEMBLY >

[REAR FINAL DRIVE: R145]

5. Assemble collapsible spacer to drive pinion.

CAUTION:

- Be careful of the mounting direction of collapsible spacer.
- Never reuse collapsible spacer.

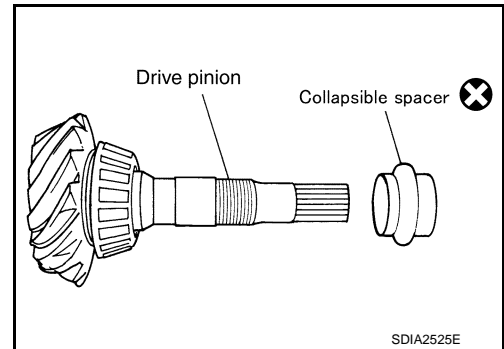

6. Apply gear oil to pinion front bearing, and assemble pinion front bearing inner race to drive pinion. Using the drifts and stand, press pinion front bearing inner race to drive pinion as far as drive pinion nut can be tightened.

- A : Drift [SST: KV40100610 (J-26089)]
 B : Drift [SST: ST38220000 (—)]
 C : Drift [SST: ST23860000 (—)]

CAUTION:

Never reuse pinion front bearing inner race.

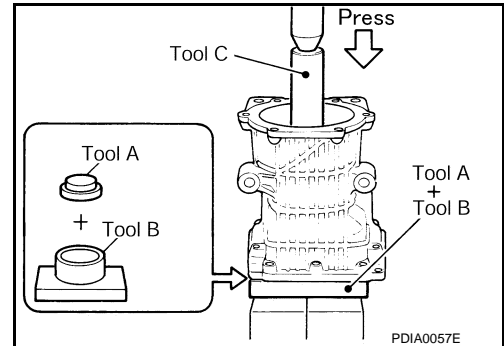

7. Apply anti-corrosive oil to the thread and seat of drive pinion nut, and temporarily tighten drive pinion nut to drive pinion.

CAUTION:

Never reuse drive pinion nut.

8. Fit the drive pinion socket onto the drive pinion spline. Using the pinion nut wrench, tighten drive pinion nut to the specified preload torque.

- A : Drive pinion socket [SST: KV38109500 (—)]
 B : Pinion nut wrench [SST: KV38109400 (—)]
 C : Preload gauge [SST: ST3127S000 (J-25765-A)]

Drive pinion tightening torque : Refer to [DLN-115, "Exploded View"](#).

Standard

Pinion bearing preload : Refer to [DLN-125, "Pre-load Torque"](#).

CAUTION:

- Adjust the lower limit of the drive pinion nut tightening torque first.
- If the preload torque exceeds the specified value, replace collapsible spacer and tighten it again to adjust. Never loosen drive pinion nut to adjust the preload torque.
- After adjustment, rotate drive pinion back and forth 2 to 3 times to check for unusual noise, rotation malfunction, and other malfunctions.

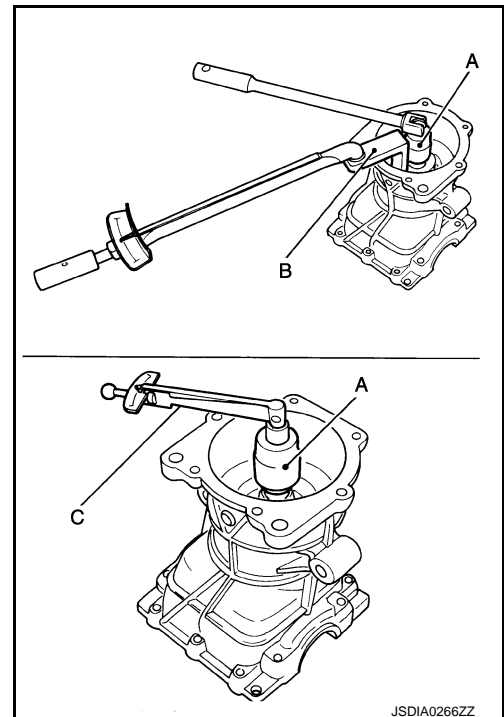

9. Install differential case assembly. Refer to [DLN-110, "Assembly"](#).

CAUTION:

Never install rear cover.

10. Install dummy cover set [SST: KV381086S1 (—)], and check drive gear runout, tooth contact, and backlash. Refer to [DLN-120, "Adjustment"](#).
11. Remove dummy cover set [SST: KV381086S1 (—)], then install rear cover, and side oil seal. Refer to [DLN-110, "Assembly"](#).
12. Check total preload torque. Refer to [DLN-120, "Adjustment"](#).

DRIVE PINION

< UNIT DISASSEMBLY AND ASSEMBLY >

[REAR FINAL DRIVE: R145]

13. Install electric controlled coupling assembly. Refer to [DLN-104, "Assembly"](#).
14. Check companion flange runout. Refer to [DLN-106, "Adjustment"](#).

Adjustment

INFOID:000000006260466

TOTAL PRELOAD TORQUE

1. Remove electric controlled coupling assembly. Refer to [DLN-104, "Disassembly"](#).
2. Rotate drive pinion back and forth 2 to 3 times to check for unusual noise and rotation malfunction.
3. Rotate drive pinion at least 20 times to check for smooth operation of the bearing.
4. Fit drive pinion socket onto drive pinion spline. Measure the total preload, using the preload gauge and drive pinion socket.

- A : Preload gauge [SST: ST3127S000 (J-27565-A)]
B : Drive pinion socket [SST: KV38109500 (—)]

Standard

Total preload torque : Refer to [DLN-125, "Preload Torque"](#).

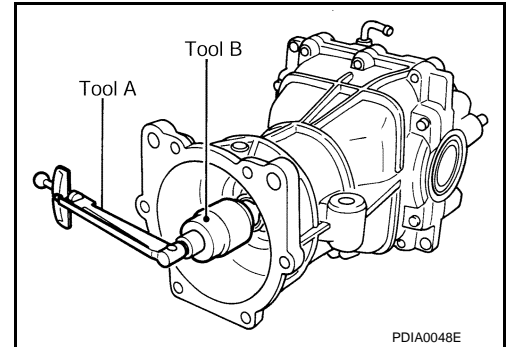

NOTE:

Total preload torque = Pinion bearing torque + Side bearing torque

- If measured value is out of the specification, disassemble it to check and adjust each part. Adjust the pinion bearing preload and side bearing preload.
Adjust the pinion bearing preload first, then adjust the side bearing preload.

When the preload torque is large

- On pinion bearings:** Replace the collapsible spacer.
- On side bearings:** Use thinner side bearing adjusting shims.

When the preload is small

- On pinion bearings:** Tighten the drive pinion nut.
- On side bearings:** Use thicker side bearing adjusting shims.

DRIVE GEAR RUNOUT

1. Remove rear cover. Refer to [DLN-109, "Disassembly"](#).
2. Following the procedure below, install a dummy cover set [SST: KV381086S1 (—)] to gear carrier.
 - a. Set dummy cover shims [SST: KV38108630 (—)] to the right and left side bearing adjusting shims.
 - b. Temporarily tighten dummy cover [SST: KV38108610 (—)] to gear carrier.
 - c. Position dummy cover spacers [SST: KY38108621 (—)] to dummy cover [SST: KV38108610 (—)].
 - d. Tighten rear cover mounting bolts to the specified torque. Refer to [DLN-115, "Exploded View"](#).
 - e. Tighten dummy cover spacer mounting bolts evenly to the specified torque.

 : 5.9 N·m (0.6 kg-m, 52 in-lb)

DRIVE PINION

< UNIT DISASSEMBLY AND ASSEMBLY >

[REAR FINAL DRIVE: R145]

3. Fit a dial indicator to the drive gear back face.
4. Rotate the drive gear to measure runout.

Limit

Drive gear back face runout

: Refer to [DLN-125, "Drive Gear Runout"](#).

- If the runout is outside of the repair limit, check drive gear assembly condition; foreign material may be caught between drive gear and differential case, or differential case or drive gear may be deformed, etc.

CAUTION:

Replace drive gear and drive pinion as a set.

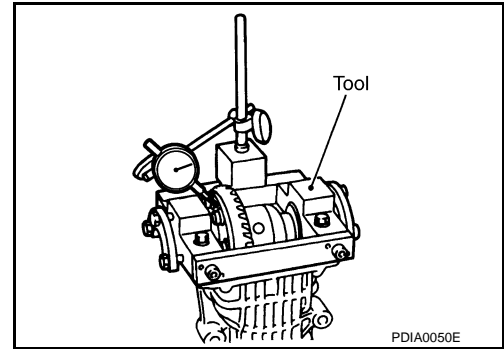

A

B

C

DLN

TOOTH CONTACT

1. Remove rear cover. Refer to [DLN-109, "Disassembly"](#).
2. Following the procedure below, install a dummy cover set [SST: KV381086S1 (—)] to gear carrier.
 - a. Set dummy cover shims [SST: KV38108630 (—)] to the right and left side bearing adjusting shims.
 - b. Temporarily tighten dummy cover [SST: KV38108620 (—)] to gear carrier.
 - c. Position dummy cover spacers [SST: KV38108621 (—)] to dummy cover [SST: KV38108620 (—)].
 - d. Tighten rear cover mounting bolts to the specified torque. Refer to [DLN-115, "Exploded View"](#).
 - e. Tighten dummy cover spacer mounting bolts evenly to the specified torque.

 : 5.9 N·m (0.6 kg·m, 52 in·lb)

3. Apply red lead to drive gear.

CAUTION:

Apply red lead to both the faces of 3 to 4 gears at 4 locations evenly spaced on drive gear.

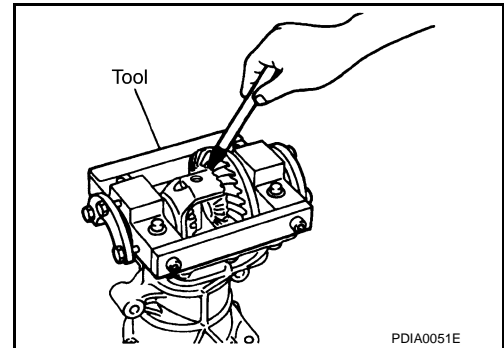

E

F

G

H

I

J

K

L

4. Rotate drive gear back and forth several times, check drive pinion gear to drive gear tooth contact.

CAUTION:

Check tooth contact on drive side and reverse side.

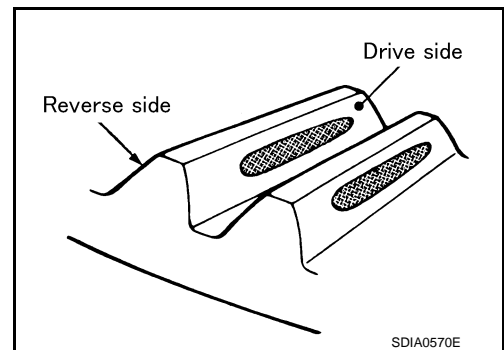

M

N

O

P

DRIVE PINION

< UNIT DISASSEMBLY AND ASSEMBLY >

[REAR FINAL DRIVE: R145]

Tooth Contact Judgment Guide

Tooth contact condition		Drive pinion adjusting shim selection value [mm (in)]	Adjustment (Yes/No)	Possible cause
Drive side	Back side			
Heel side 	Toe side 	↑ Thicker	Yes	Occurrence of noise and scoring sound in all speed ranges.
				+0.09 (+0.0035)
		+0.06 (+0.0024)	No	-
		+0.03 (+0.0012)		
		0		
		↓ Thinner	Yes	Occurrence of noise at constant speed and decreasing speed.
				-0.03 (-0.0012)
		-0.06 (-0.0024)	Yes	Occurrence of noise and scoring sound in all speed ranges.
		-0.09 (-0.0035)		

SDIA2549E

5. If tooth contact is improperly adjusted, follow the procedure below to adjust the pinion height (dimension X).

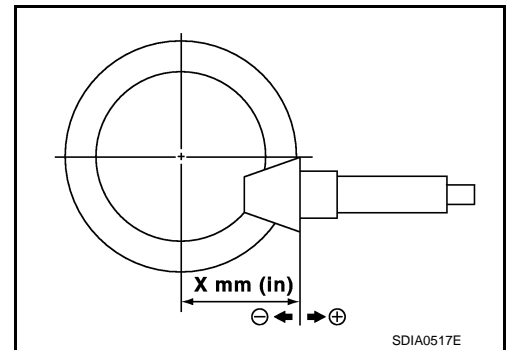

- If the tooth contact is near the face (face contact), or near the heel (heel contact), thicken drive pinion gear adjusting shim to move drive pinion closer to drive gear.

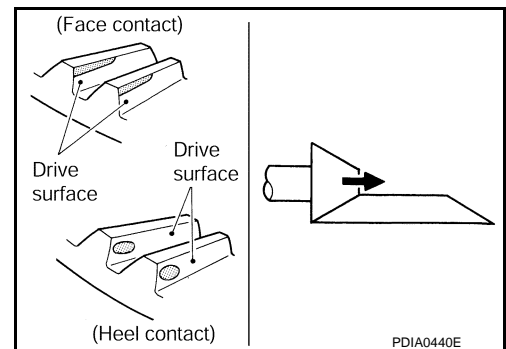

DRIVE PINION

< UNIT DISASSEMBLY AND ASSEMBLY >

[REAR FINAL DRIVE: R145]

- If the tooth contact is near the flank (flank contact), or near the toe (toe contact), thin drive pinion gear adjusting shim to move drive pinion farther from drive gear.

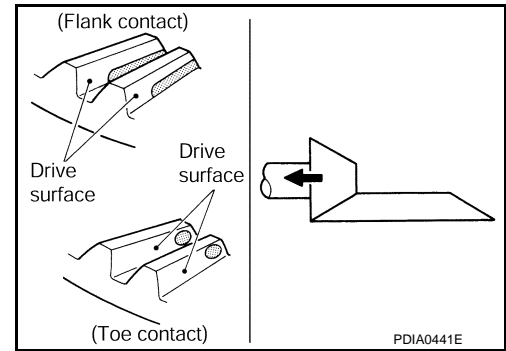

BACKLASH

1. Remove rear cover. Refer to [DLN-109, "Disassembly"](#).
2. Following the procedure below, install a dummy cover set [SST: KV381086S1 (—)] to gear carrier.
 - a. Set dummy cover shims [SST: KV38108630 (—)] to the right and left side bearing adjusting shims.
 - b. Temporarily tighten dummy cover [SST: KV38108610 (—)] to gear carrier.
 - c. Position dummy cover spacers [SST: KV38108621 (—)] to dummy cover [SST: KV38108610 (—)].
 - d. Tighten rear cover mounting bolts to the specified torque. Refer to [DLN-115, "Exploded View"](#).
 - e. Tighten dummy cover spacer mounting bolts evenly to the specified torque.

 : 5.9 N·m (0.6 kg·m, 52 in·lb)

3. Fit a dial indicator to the drive gear face to measure the backlash.

**Standard
Backlash**

: Refer to [DLN-125, "Backlash"](#).

- If the backlash is outside of the specified value, change the thickness of side bearing adjusting shims.

When the backlash is large:

Make drive gear back adjusting shims thicker, and drive gear front adjusting shims thinner.

When the backlash is small:

Make drive gear back adjusting shims thinner, and drive gear front adjusting shims thicker.

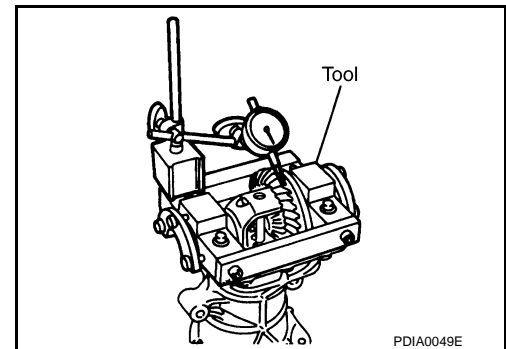

Inspection After Disassembly

INFOID:000000006260467

DRIVE GEAR AND DRIVE PINION

- Clean up the disassembled parts.
- If the gear teeth never mesh or line-up correctly, determine the cause and adjust or replace as necessary.
- If the gears are worn, cracked, damaged, pitted or chipped (by friction) noticeably, replace with new drive gear and drive pinion as a set.

BEARING

- Clean up the disassembled parts.
- If any chipped (by friction), pitted, worn, rusted or scratched marks, or unusual noise from the bearing is observed, replace as a bearing assembly (as a new set).

SIDE GEAR AND PINION MATE GEAR

DRIVE PINION

< UNIT DISASSEMBLY AND ASSEMBLY >

[REAR FINAL DRIVE: R145]

- Clean up the disassembled parts.
- If any cracks or damage on the surface of the tooth is found, replace.
- If any worn or chipped mark on the contact sides of the thrust washer is found, replace.

SIDE GEAR THRUST WASHER AND PINION MATE THRUST WASHER

- Clean up the disassembled parts.
- If it is chipped (by friction), damaged, or unusually worn, replace.

OIL SEAL

- Whenever disassembled, replace.
- If wear, deterioration of adherence (sealing force lips), or damage is detected on the lips, replace them.

DIFFERENTIAL CASE

- Clean up the disassembled parts.
- If any wear or crack on the contact sides of the differential case is found, replace.

COMPANION FLANGE

- Clean up the disassembled parts.
- If any chipped mark [about 0.1 mm, (0.004 in)] or other damage on the contact sides of the lips of the companion flange is found, replace.

SERVICE DATA AND SPECIFICATIONS (SDS)

< SERVICE DATA AND SPECIFICATIONS (SDS)

[REAR FINAL DRIVE: R145]

SERVICE DATA AND SPECIFICATIONS (SDS)

SERVICE DATA AND SPECIFICATIONS (SDS)

General Specification

INFOID:000000006260468

Applied model	AWD
	VQ35DE
	CVT
Final drive model	R145
Gear ratio	2.466
Number of teeth (Drive gear/Drive pinion)	37/15
Oil capacity (Approx.) ℓ (US pt, Imp pt)	0.55 (1-1/8, 1)
Number of pinion gears	2
Drive pinion adjustment spacer type	Collapsible

Drive Gear Runout

INFOID:000000006260469

Unit: mm (in)

Item	Limit
Drive gear back face runout	0.05 (0.0020)

Differential Side Gear Clearance

INFOID:000000006260470

Unit: mm (in)

Item	Standard
Side gear backlash (Clearance between side gear and differential case)	0.2 (0.008) or less (Each gear should rotate smoothly without excessive resistance during differential motion.)

Preload Torque

INFOID:000000006260471

Unit: N·m (kg·m, in·lb)

Item	Standard
Pinion bearing (P1)	0.69 – 1.18 (0.07 – 0.12, 7 – 10)
Side bearing (P2)	0.64 – 0.98 (0.07 – 0.09, 6 – 8)
Side bearing to pinion bearing (Total preload) (Total preload = P1 + P2)	1.33 – 2.16 (0.14 – 0.22, 12 – 19)

Backlash

INFOID:000000006260472

Unit: mm (in)

Item	Standard
Drive gear to drive pinion gear	0.10 – 0.15 (0.0039 – 0.0059)

Companion Flange Runout

INFOID:000000006260473

Unit: mm (in)

Item	Limit
Companion flange face	0.13 (0.0051)
Inner side of the companion flange	0.19 (0.0075)