

A
EM
C
D
E
F
G
H
I
J
K
L
M
N
O
P

SECTION **EM**

ENGINE MECHANICAL

CONTENTS

<p>SYMPTOM DIAGNOSIS 4</p> <p>NOISE, VIBRATION AND HARSHNESS (NVH) TROUBLESHOOTING 4</p> <p style="padding-left: 20px;">NVH Troubleshooting - Engine Noise4</p> <p style="padding-left: 20px;">Use the Chart Below to Help You Find the Cause of the Symptom5</p> <p>PRECAUTION 6</p> <p>PRECAUTIONS 6</p> <p>FOR USA AND CANADA6</p> <p style="padding-left: 20px;">FOR USA AND CANADA : Precaution for Procedure without Cowl Top Cover6</p> <p style="padding-left: 20px;">FOR USA AND CANADA : Precaution for Supplemental Restraint System (SRS) "AIR BAG" and "SEAT BELT PRE-TENSIONER"6</p> <p style="padding-left: 20px;">FOR USA AND CANADA : Precautions Necessary for Steering Wheel Rotation After Battery Disconnection6</p> <p style="padding-left: 20px;">FOR USA AND CANADA : Precaution for Drain Engine Coolant and Engine Oil7</p> <p style="padding-left: 20px;">FOR USA AND CANADA : Precaution for Disconnecting Fuel Piping7</p> <p style="padding-left: 20px;">FOR USA AND CANADA : Precaution for Removal and Disassembly7</p> <p style="padding-left: 20px;">FOR USA AND CANADA : Precaution for Inspection, Repair and Replacement7</p> <p style="padding-left: 20px;">FOR USA AND CANADA : Precaution for Assembly and Installation7</p> <p style="padding-left: 20px;">FOR USA AND CANADA : Precaution for Angle Tightening8</p> <p style="padding-left: 20px;">FOR USA AND CANADA : Precaution for Liquid Gasket8</p> <p>FOR MEXICO9</p> <p style="padding-left: 20px;">FOR MEXICO : Precaution for Procedure without Cowl Top Cover9</p>	<p style="padding-left: 20px;">FOR MEXICO : Precaution for Supplemental Restraint System (SRS) "AIR BAG" and "SEAT BELT PRE-TENSIONER" 9</p> <p style="padding-left: 20px;">FOR MEXICO : Precautions Necessary for Steering Wheel Rotation After Battery Disconnection 9</p> <p style="padding-left: 20px;">FOR MEXICO : Precaution for Drain Engine Coolant and Engine Oil10</p> <p style="padding-left: 20px;">FOR MEXICO : Precaution for Disconnecting Fuel Piping10</p> <p style="padding-left: 20px;">FOR MEXICO : Precaution for Removal and Disassembly10</p> <p style="padding-left: 20px;">FOR MEXICO : Precaution for Inspection, Repair and Replacement10</p> <p style="padding-left: 20px;">FOR MEXICO : Precaution for Assembly and Installation10</p> <p style="padding-left: 20px;">FOR MEXICO : Precaution for Angle Tightening11</p> <p style="padding-left: 20px;">FOR MEXICO : Precaution for Liquid Gasket11</p> <p>PREPARATION13</p> <p>PREPARATION13</p> <p style="padding-left: 20px;">Special Service Tool13</p> <p style="padding-left: 20px;">Commercial Service Tool14</p> <p>PERIODIC MAINTENANCE17</p> <p>DRIVE BELT17</p> <p style="padding-left: 20px;">Exploded View17</p> <p style="padding-left: 20px;">Checking17</p> <p style="padding-left: 20px;">Tension Adjustment17</p> <p style="padding-left: 20px;">Removal and Installation17</p> <p>AIR CLEANER FILTER19</p> <p style="padding-left: 20px;">Removal and Installation19</p> <p>SPARK PLUG20</p> <p style="padding-left: 20px;">Exploded View20</p> <p style="padding-left: 20px;">Removal and Installation20</p> <p style="padding-left: 20px;">Inspection21</p> <p>CAMSHAFT VALVE CLEARANCE22</p> <p style="padding-left: 20px;">Inspection and Adjustment22</p>
---	---

COMPRESSION PRESSURE	27	AWD	81
Inspection	27	AWD : Exploded View	81
REMOVAL AND INSTALLATION	29	AWD : Removal and Installation	82
ENGINE COVER	29	AWD : Inspection	89
Exploded View	29	UNIT DISASSEMBLY AND ASSEMBLY ...	90
Removal and Installation	29	ENGINE STAND SETTING	90
DRIVE BELT AUTO TENSIONER AND IDLER		Setting	90
PULLEY	30	ENGINE UNIT	92
Exploded View	30	Disassembly	92
Removal and Installation	30	Assembly	92
AIR CLEANER AND AIR DUCT	31	REAR TIMING CHAIN CASE	93
Exploded View	31	Exploded View	93
Removal and Installation	31	Disassembly and Assembly	94
Inspection	32	CAMSHAFT	98
INTAKE MANIFOLD COLLECTOR	33	Exploded View	98
Exploded View	33	Removal and Installation	98
Removal and Installation	33	Inspection	102
INTAKE MANIFOLD	36	OIL SEAL	108
Exploded View	36	VALVE OIL SEAL	108
Removal and Installation	36	VALVE OIL SEAL : Removal and Installation	108
Inspection	37	FRONT OIL SEAL	108
EXHAUST MANIFOLD AND THREE WAY		FRONT OIL SEAL : Removal and Installation	108
CATALYST	38	REAR OIL SEAL	109
Exploded View	38	REAR OIL SEAL : Removal and Installation	109
Removal and Installation	38	CYLINDER HEAD	111
Inspection	42	Exploded View	111
OIL PAN AND OIL STRAINER	43	Removal and Installation	112
Exploded View	43	Disassembly and Assembly	115
Removal and Installation	43	Inspection	119
Inspection	47	CYLINDER BLOCK	122
FUEL INJECTOR AND FUEL TUBE	49	Exploded View	122
Exploded View	49	Disassembly and Assembly	123
Removal and Installation	49	Inspection	131
Inspection	53	HOW TO SELECT PISTON AND BEARING ..	141
IGNITION COIL, SPARK PLUG AND ROCK-		Description	141
ER COVER	54	Piston	141
Exploded View	54	Connecting Rod Bearing	142
Removal and Installation	54	Main Bearing	143
TIMING CHAIN	57	SERVICE DATA AND SPECIFICATIONS	
Exploded View	57	(SDS)	146
Removal and Installation	58	SERVICE DATA AND SPECIFICATIONS	
Inspection	70	(SDS)	146
UNIT REMOVAL AND INSTALLATION	72	General Specification	146
ENGINE ASSEMBLY	72	Drive Belt	146
2WD	72	Spark Plug	147
2WD : Exploded View	72	Intake Manifold	147
2WD : Removal and Installation	73	Exhaust Manifold	147
2WD : Inspection	80	Camshaft	147

Cylinder Head	149	Main Bearing	154
Cylinder Block	151	Connecting Rod Bearing	155

A

EM

C

D

E

F

G

H

I

J

K

L

M

N

O

P

NOISE, VIBRATION AND HARSHNESS (NVH) TROUBLESHOOTING

< SYMPTOM DIAGNOSIS >

SYMPTOM DIAGNOSIS

NOISE, VIBRATION AND HARSHNESS (NVH) TROUBLESHOOTING

NVH Troubleshooting - Engine Noise

INFOID:000000006260574

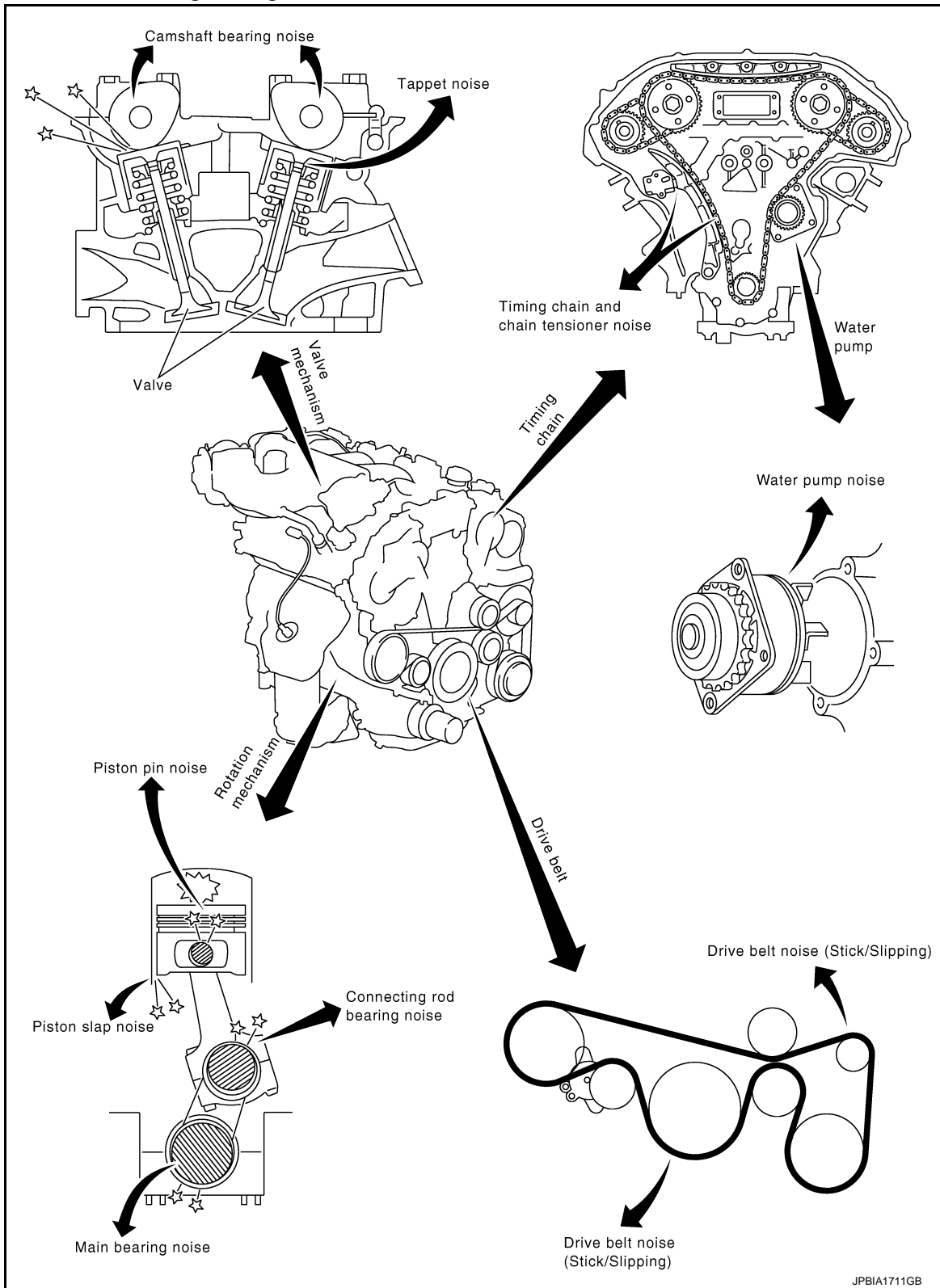

NOISE, VIBRATION AND HARSHNESS (NVH) TROUBLESHOOTING

< SYMPTOM DIAGNOSIS >

Use the Chart Below to Help You Find the Cause of the Symptom

INFOID:000000006260575

1. Locate the area where noise occurs.
2. Confirm the type of noise.
3. Specify the operating condition of the engine.
4. Check specified noise source.
If necessary, repair or replace these parts.

Location of noise	Type of noise	Operating condition of engine						Source of noise	Check item	Reference page
		Before warm-up	After warm-up	When starting	When idling	When racing	While driving			
Top of engine Rocker cover Cylinder head	Ticking or clicking	C	A	—	A	B	—	Tappet noise	Valve clearance	EM-22
	Rattle	C	A	—	A	B	C	Camshaft bearing noise	Camshaft runout Camshaft journal oil clearance	EM-147
Crankshaft pulley Cylinder block (Side of engine) Oil pan	Slap or knock	—	A	—	B	B	—	Piston pin noise	Piston to piston pin oil clearance Connecting rod bushing oil clearance	EM-151
	Slap or rap	A	—	—	B	B	A	Piston slap noise	Piston to cylinder bore clearance Piston ring side clearance Piston ring end gap Connecting rod bend and torsion	EM-151
	Knock	A	B	C	B	B	B	Connecting rod bearing noise	Connecting rod bushing oil clearance Connecting rod bearing oil clearance	EM-151 EM-155
	Knock	A	B	—	A	B	C	Main bearing noise	Main bearing oil clearance Crankshaft runout	EM-154 EM-151
Front of engine Timing chain case	Tapping or ticking	A	A	—	B	B	B	Timing chain and timing chain tensioner noise	Timing chain cracks and wear Timing chain tensioner operation	EM-70 EM-57
Front of engine	Squeaking or fizzing	A	B	—	B	—	C	Drive belt (Sticking or slipping)	Drive belt deflection	EM-17
	Creaking	A	B	A	B	A	B	Drive belt (Slipping)	Idler pulley bearing operation	
	Squall Creak	A	B	—	B	A	B	Water pump noise	Water pump operation	CO-21, "Exploded View"

A: Closely related B: Related C: Sometimes related —: Not related

PRECAUTIONS

< PRECAUTION >

PRECAUTION

PRECAUTIONS

FOR USA AND CANADA

FOR USA AND CANADA : Precaution for Procedure without Cowl Top Cover

INFOID:000000006260576

When performing the procedure after removing cowl top cover, cover the lower end of windshield with urethane, etc to prevent damage to windshield.

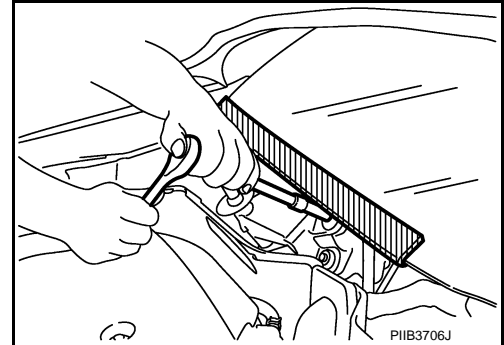

FOR USA AND CANADA : Precaution for Supplemental Restraint System (SRS) "AIR BAG" and "SEAT BELT PRE-TENSIONER"

INFOID:000000006260577

The Supplemental Restraint System such as "AIR BAG" and "SEAT BELT PRE-TENSIONER", used along with a front seat belt, helps to reduce the risk or severity of injury to the driver and front passenger for certain types of collision. This system includes seat belt switch inputs and dual stage front air bag modules. The SRS system uses the seat belt switches to determine the front air bag deployment, and may only deploy one front air bag, depending on the severity of a collision and whether the front occupants are belted or unbelted. Information necessary to service the system safely is included in the "SRS AIR BAG" and "SEAT BELT" of this Service Manual.

WARNING:

Always observe the following items for preventing accidental activation.

- To avoid rendering the SRS inoperative, which could increase the risk of personal injury or death in the event of a collision that would result in air bag inflation, all maintenance must be performed by an authorized NISSAN/INFINITI dealer.
- Improper maintenance, including incorrect removal and installation of the SRS, can lead to personal injury caused by unintentional activation of the system. For removal of Spiral Cable and Air Bag Module, see "SRS AIR BAG".
- Never use electrical test equipment on any circuit related to the SRS unless instructed to in this Service Manual. SRS wiring harnesses can be identified by yellow and/or orange harnesses or harness connectors.

PRECAUTIONS WHEN USING POWER TOOLS (AIR OR ELECTRIC) AND HAMMERS

WARNING:

Always observe the following items for preventing accidental activation.

- When working near the Air Bag Diagnosis Sensor Unit or other Air Bag System sensors with the ignition ON or engine running, never use air or electric power tools or strike near the sensor(s) with a hammer. Heavy vibration could activate the sensor(s) and deploy the air bag(s), possibly causing serious injury.
- When using air or electric power tools or hammers, always switch the ignition OFF, disconnect the battery, and wait at least 3 minutes before performing any service.

FOR USA AND CANADA : Precautions Necessary for Steering Wheel Rotation After Battery Disconnection

INFOID:000000006260578

CAUTION:

Comply with the following cautions to prevent any error and malfunction.

- Before removing and installing any control units, first turn the ignition switch to the LOCK position, then disconnect both battery cables.

PRECAUTIONS

< PRECAUTION >

- After finishing work, confirm that all control unit connectors are connected properly, then re-connect both battery cables.
- Always use CONSULT to perform self-diagnosis as a part of each function inspection after finishing work. If a DTC is detected, perform trouble diagnosis according to self-diagnosis results.

For vehicle with steering lock unit, if the battery is disconnected or discharged, the steering wheel will lock and cannot be turned.

If turning the steering wheel is required with the battery disconnected or discharged, follow the operation procedure below before starting the repair operation.

OPERATION PROCEDURE

1. Connect both battery cables.

NOTE:

Supply power using jumper cables if battery is discharged.

2. Turn the ignition switch to ACC position.
(At this time, the steering lock will be released.)
3. Disconnect both battery cables. The steering lock will remain released with both battery cables disconnected and the steering wheel can be turned.
4. Perform the necessary repair operation.
5. When the repair work is completed, re-connect both battery cables. With the brake pedal released, turn the ignition switch from ACC position to ON position, then to LOCK position. (The steering wheel will lock when the ignition switch is turned to LOCK position.)
6. Perform self-diagnosis check of all control units using CONSULT.

FOR USA AND CANADA : Precaution for Drain Engine Coolant and Engine Oil

INFOID:0000000006260579

Drain engine coolant and engine oil when the engine is cooled.

FOR USA AND CANADA : Precaution for Disconnecting Fuel Piping

INFOID:0000000006260580

- Before starting work, check no fire or spark producing items are in the work area.
- Release fuel pressure before disconnecting and disassembly.
- After disconnecting pipes, plug openings to stop fuel leakage.

FOR USA AND CANADA : Precaution for Removal and Disassembly

INFOID:0000000006260581

- When instructed to use SST, use the specified tools. Always be careful to work safely, avoid forceful or uninstructed operations.
- Exercise maximum care to avoid damage to mating or sliding surfaces.
- Dowel pins are used for several parts alignment. When replacing and reassembling parts with dowel pins, check that dowel pins are installed in the original position.
- Cover openings of engine system with a tape or the equivalent, if necessary, to seal out foreign materials.
- Mark and arrange disassembly parts in an organized way for easy troubleshooting and reassembly.
- When loosening nuts and bolts, as a basic rule, start with the one furthest outside, then the one diagonally opposite, and so on. If the order of loosening is specified, do exactly as specified. Power tools may be used in the step.

FOR USA AND CANADA : Precaution for Inspection, Repair and Replacement

INFOID:0000000006260582

Before repairing or replacing, thoroughly inspect parts. Inspect new replacement parts in the same way, and replace if necessary.

FOR USA AND CANADA : Precaution for Assembly and Installation

INFOID:0000000006260583

- Use torque wrench to tighten bolts or nuts to specification.
- When tightening nuts and bolts, as a basic rule, equally tighten in several different steps starting with the ones in center, then ones on inside and outside diagonally in this order. If the order of tightening is specified, do exactly as specified.
- Replace with new gasket, packing, oil seal or O-ring.
- Dowel pins are used for several parts alignment. When replacing and reassembling parts with dowel pins, check that dowel pins are installed in the original position.

PRECAUTIONS

< PRECAUTION >

- Thoroughly wash, clean, and air-blow each part. Carefully check engine oil or engine coolant passages for any restriction and blockage.
- Avoid damaging sliding or mating surfaces. Completely remove foreign materials such as cloth lint or dust. Before assembly, oil sliding surfaces well.
- Release air within route when refilling after draining engine coolant.
- After repairing, start the engine and increase engine speed to check engine coolant, fuel, engine oil, and exhaust gases for leakage.

FOR USA AND CANADA : Precaution for Angle Tightening

INFOID:000000006260584

- Use the angle wrench [SST: KV10112100 (BT8653-A)] for the final tightening of the following engine parts:
 - Cylinder head bolts
 - Main bearing cap bolts
 - Connecting rod cap bolts
 - Crankshaft pulley bolt (No the angle wrench is required as bolt flange is provided with notches for angle tightening)
- Never use a torque value for final tightening.
- The torque value for these parts are for a preliminary step.
- Ensure thread and seat surfaces are clean and coated with engine oil.

FOR USA AND CANADA : Precaution for Liquid Gasket

INFOID:000000006260585

REMOVAL OF LIQUID GASKET SEALING

- After removing mounting nuts and bolts, separate the mating surface using the seal cutter [SST: KV10111100 (J-37228)] (A) and remove old liquid gasket sealing.

CAUTION:

Be careful not to damage the mating surfaces.

- Tap (B) the seal cutter [SST: KV10111100 (J-37228)] to insert it, and then slide (C) it by tapping on the side as shown in the figure.
- In areas where the seal cutter [SST: KV10111100 (J-37228)] is difficult to use, use a plastic hammer to lightly tap the parts, to remove it.

CAUTION:

If for some unavoidable reason tool such as a screwdriver is used, be careful not to damage the mating surfaces.

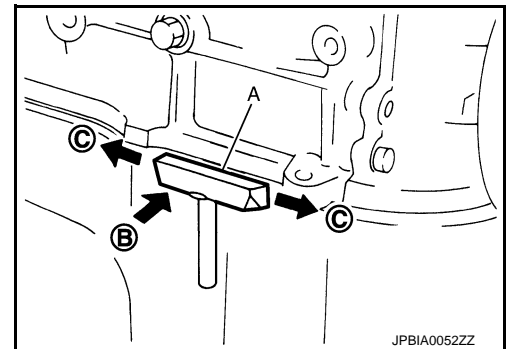

LIQUID GASKET APPLICATION PROCEDURE

1. Using a scraper (A), remove old liquid gasket adhering to the gasket application surface and the mating surface.
 - Remove liquid gasket completely from the groove of the gasket application surface, mounting bolts, and bolt holes.
2. Wipe the liquid gasket application surface and the mating surface with white gasoline (lighting and heating use) to remove adhering moisture, grease and foreign materials.

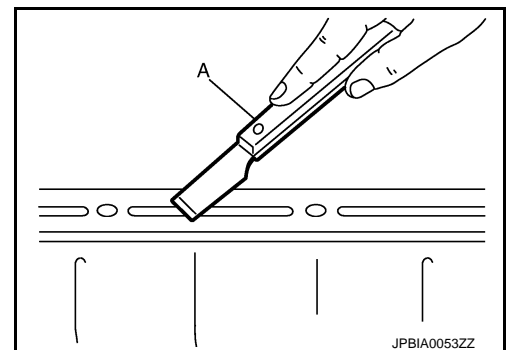

3. Attach liquid gasket tube to the tube presser (commercial service tool).
Use Genuine RTV Silicone Sealant or equivalent. Refer to [GI-22. "Recommended Chemical Products and Sealants"](#).
4. Apply liquid gasket without breaks to the specified location with the specified dimensions.
 - If there is a groove for liquid gasket application, apply liquid gasket to the groove.

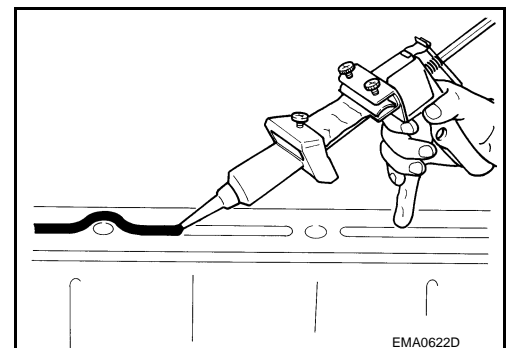

PRECAUTIONS

< PRECAUTION >

- As for bolt holes, normally apply liquid gasket inside the holes. Occasionally, it should be applied outside the holes. Check to read the text of this manual.
- Within 5 minutes of liquid gasket application, install the mating component.
- If liquid gasket protrudes, wipe it off immediately.
- Never retighten mounting bolts or nuts after the installation.
- After 30 minutes or more have passed from the installation, fill engine oil and engine coolant.

CAUTION:

If there are specific instructions in this manual, observe them.

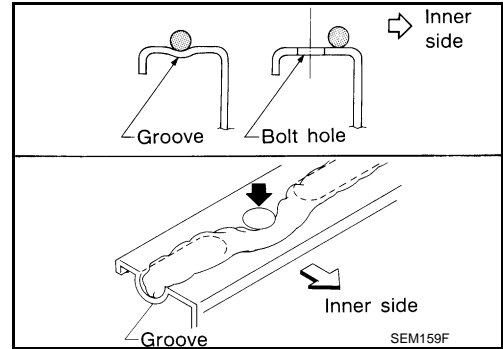

FOR MEXICO

FOR MEXICO : Precaution for Procedure without Cowl Top Cover

INFOID:000000006260586

When performing the procedure after removing cowl top cover, cover the lower end of windshield with urethane, etc to prevent damage to windshield.

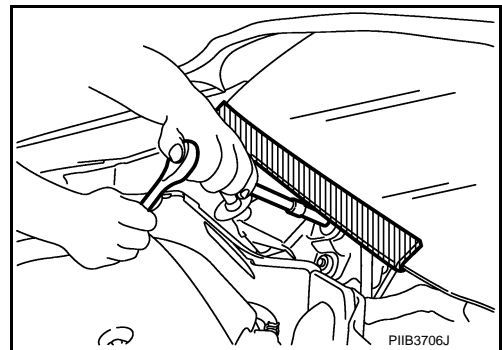

FOR MEXICO : Precaution for Supplemental Restraint System (SRS) "AIR BAG" and "SEAT BELT PRE-TENSIONER"

INFOID:000000006260587

The Supplemental Restraint System such as "AIR BAG" and "SEAT BELT PRE-TENSIONER", used along with a front seat belt, helps to reduce the risk or severity of injury to the driver and front passenger for certain types of collision. Information necessary to service the system safely is included in the "SRS AIR BAG" and "SEAT BELT" of this Service Manual.

WARNING:

Always observe the following items for preventing accidental activation.

- To avoid rendering the SRS inoperative, which could increase the risk of personal injury or death in the event of a collision that would result in air bag inflation, all maintenance must be performed by an authorized NISSAN/INFINITI dealer.
- Improper maintenance, including incorrect removal and installation of the SRS, can lead to personal injury caused by unintentional activation of the system. For removal of Spiral Cable and Air Bag Module, see "SRS AIR BAG".
- Never use electrical test equipment on any circuit related to the SRS unless instructed to in this Service Manual. SRS wiring harnesses can be identified by yellow and/or orange harnesses or harness connectors.

PRECAUTIONS WHEN USING POWER TOOLS (AIR OR ELECTRIC) AND HAMMERS

WARNING:

Always observe the following items for preventing accidental activation.

- When working near the Air Bag Diagnosis Sensor Unit or other Air Bag System sensors with the ignition ON or engine running, never use air or electric power tools or strike near the sensor(s) with a hammer. Heavy vibration could activate the sensor(s) and deploy the air bag(s), possibly causing serious injury.
- When using air or electric power tools or hammers, always switch the ignition OFF, disconnect the battery, and wait at least 3 minutes before performing any service.

FOR MEXICO : Precautions Necessary for Steering Wheel Rotation After Battery Dis-

PRECAUTIONS

< PRECAUTION >

connection

INFOID:000000006260588

CAUTION:

Comply with the following cautions to prevent any error and malfunction.

- Before removing and installing any control units, first turn the ignition switch to the LOCK position, then disconnect both battery cables.
- After finishing work, confirm that all control unit connectors are connected properly, then re-connect both battery cables.
- Always use CONSULT to perform self-diagnosis as a part of each function inspection after finishing work. If a DTC is detected, perform trouble diagnosis according to self-diagnosis results.

For vehicle with steering lock unit, if the battery is disconnected or discharged, the steering wheel will lock and cannot be turned.

If turning the steering wheel is required with the battery disconnected or discharged, follow the operation procedure below before starting the repair operation.

OPERATION PROCEDURE

1. Connect both battery cables.

NOTE:

Supply power using jumper cables if battery is discharged.

2. Turn the ignition switch to ACC position.
(At this time, the steering lock will be released.)
3. Disconnect both battery cables. The steering lock will remain released with both battery cables disconnected and the steering wheel can be turned.
4. Perform the necessary repair operation.
5. When the repair work is completed, re-connect both battery cables. With the brake pedal released, turn the ignition switch from ACC position to ON position, then to LOCK position. (The steering wheel will lock when the ignition switch is turned to LOCK position.)
6. Perform self-diagnosis check of all control units using CONSULT.

FOR MEXICO : Precaution for Drain Engine Coolant and Engine Oil

INFOID:000000006260589

Drain engine coolant and engine oil when the engine is cooled.

FOR MEXICO : Precaution for Disconnecting Fuel Piping

INFOID:000000006260590

- Before starting work, check no fire or spark producing items are in the work area.
- Release fuel pressure before disconnecting and disassembly.
- After disconnecting pipes, plug openings to stop fuel leakage.

FOR MEXICO : Precaution for Removal and Disassembly

INFOID:000000006260591

- When instructed to use SST, use the specified tools. Always be careful to work safely, avoid forceful or uninstructed operations.
- Exercise maximum care to avoid damage to mating or sliding surfaces.
- Dowel pins are used for several parts alignment. When replacing and reassembling parts with dowel pins, check that dowel pins are installed in the original position.
- Cover openings of engine system with a tape or the equivalent, if necessary, to seal out foreign materials.
- Mark and arrange disassembly parts in an organized way for easy troubleshooting and reassembly.
- When loosening nuts and bolts, as a basic rule, start with the one furthest outside, then the one diagonally opposite, and so on. If the order of loosening is specified, do exactly as specified. Power tools may be used in the step.

FOR MEXICO : Precaution for Inspection, Repair and Replacement

INFOID:000000006260592

Before repairing or replacing, thoroughly inspect parts. Inspect new replacement parts in the same way, and replace if necessary.

FOR MEXICO : Precaution for Assembly and Installation

INFOID:000000006260593

- Use torque wrench to tighten bolts or nuts to specification.

PRECAUTIONS

< PRECAUTION >

- When tightening nuts and bolts, as a basic rule, equally tighten in several different steps starting with the ones in center, then ones on inside and outside diagonally in this order. If the order of tightening is specified, do exactly as specified.
- Replace with new gasket, packing, oil seal or O-ring.
- Dowel pins are used for several parts alignment. When replacing and reassembling parts with dowel pins, check that dowel pins are installed in the original position.
- Thoroughly wash, clean, and air-blow each part. Carefully check engine oil or engine coolant passages for any restriction and blockage.
- Avoid damaging sliding or mating surfaces. Completely remove foreign materials such as cloth lint or dust. Before assembly, oil sliding surfaces well.
- Release air within route when refilling after draining engine coolant.
- After repairing, start the engine and increase engine speed to check engine coolant, fuel, engine oil, and exhaust gases for leakage.

FOR MEXICO : Precaution for Angle Tightening

INFOID:000000006260594

- Use the angle wrench [SST: KV10112100 (BT8653-A)] for the final tightening of the following engine parts:
 - Cylinder head bolts
 - Main bearing cap bolts
 - Connecting rod cap bolts
 - Crankshaft pulley bolt (No the angle wrench is required as bolt flange is provided with notches for angle tightening)
- Never use a torque value for final tightening.
- The torque value for these parts are for a preliminary step.
- Ensure thread and seat surfaces are clean and coated with engine oil.

FOR MEXICO : Precaution for Liquid Gasket

INFOID:000000006260595

REMOVAL OF LIQUID GASKET SEALING

- After removing mounting nuts and bolts, separate the mating surface using the seal cutter [SST: KV10111100 (J-37228)] (A) and remove old liquid gasket sealing.

CAUTION:

Be careful not to damage the mating surfaces.

- Tap (B) the seal cutter [SST: KV10111100 (J-37228)] to insert it, and then slide (C) it by tapping on the side as shown in the figure.
- In areas where the seal cutter [SST: KV10111100 (J-37228)] is difficult to use, use a plastic hammer to lightly tap the parts, to remove it.

CAUTION:

If for some unavoidable reason tool such as a screwdriver is used, be careful not to damage the mating surfaces.

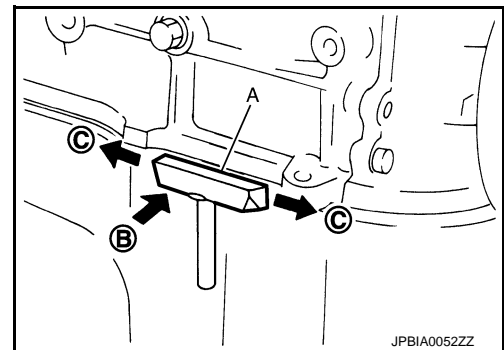

LIQUID GASKET APPLICATION PROCEDURE

1. Using a scraper (A), remove old liquid gasket adhering to the gasket application surface and the mating surface.
 - Remove liquid gasket completely from the groove of the gasket application surface, mounting bolts, and bolt holes.
2. Wipe the liquid gasket application surface and the mating surface with white gasoline (lighting and heating use) to remove adhering moisture, grease and foreign materials.

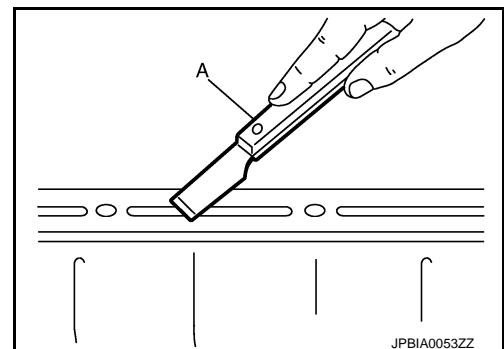

PRECAUTIONS

< PRECAUTION >

3. Attach liquid gasket tube to the tube presser (commercial service tool).
Use Genuine RTV Silicone Sealant or equivalent. Refer to [GI-22. "Recommended Chemical Products and Sealants"](#).
4. Apply liquid gasket without breaks to the specified location with the specified dimensions.
 - If there is a groove for liquid gasket application, apply liquid gasket to the groove.

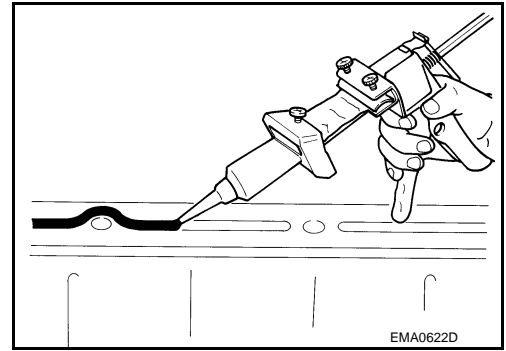

- As for bolt holes, normally apply liquid gasket inside the holes. Occasionally, it should be applied outside the holes. Check to read the text of this manual.
- Within 5 minutes of liquid gasket application, install the mating component.
- If liquid gasket protrudes, wipe it off immediately.
- Never retighten mounting bolts or nuts after the installation.
- After 30 minutes or more have passed from the installation, fill engine oil and engine coolant.

CAUTION:

If there are specific instructions in this manual, observe them.

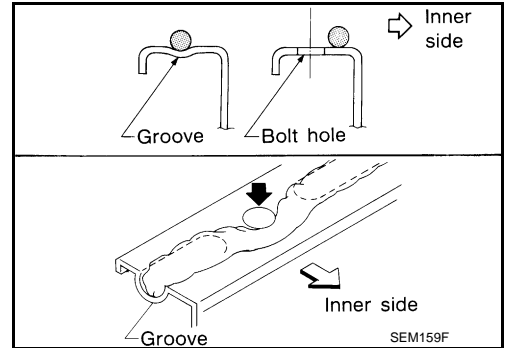

PREPARATION

< PREPARATION >

PREPARATION

PREPARATION

Special Service Tool

INFOID:000000006260596

A

EM

The actual shapes of Kent-Moore tools may differ from those of special service tools illustrated here.

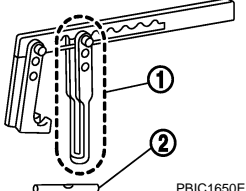
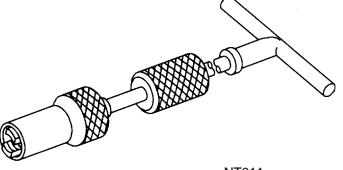
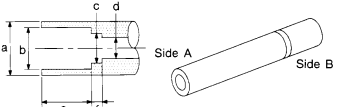
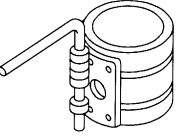
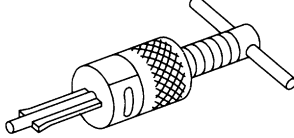
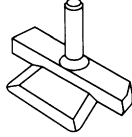
Tool number (Kent-Moore No.) Tool name	Description
KV10116200 (J-26336-A) Valve spring compressor 1. KV10115900 (J-26336-20) Attachment 2. KV10109220 (—) Adapter	 Disassembling valve mechanism Part (1) is a component of KV10116200 (J-26336-A), but Part (2) is not so.
KV10107902 (J-38959) Valve oil seal puller	 Replacing valve oil seal
KV10115600 (J-38958) Valve oil seal drift	 Installing valve oil seal Use side A. a: 20 mm (0.79 in) dia. b: 13 mm (0.51 in) dia. c: 10.3 mm (0.406 in) dia. d: 8 mm (0.31 in) dia. e: 10.7 mm (0.421 in) f: 5 mm (0.20 in)
EM03470000 (J-8037) Piston ring compressor	 Installing piston assembly into cylinder bore
ST16610001 (J-23907) Pilot bushing puller	 Removing pilot converter
KV10111100 (J-37228) Seal cutter	 Removing oil pan (lower and upper), front and rear timing chain case, etc.

C

D

E

F

G

H

I

J

K

L

M

N

O

P

PREPARATION

< PREPARATION >

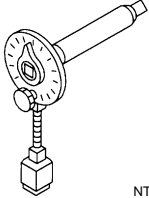
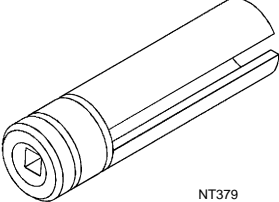
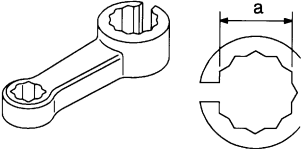
Tool number (Kent-Moore No.) Tool name	Description
KV10112100 (BT8653-A) Angle wrench  NT014	Tightening bolts for connecting rod bearing cap, cylinder head, etc. in angle
KV10117100 (J-3647-A) Heated oxygen sensor wrench  NT379	Loosening or tightening air fuel ratio sensor 1 For 22 mm (0.87 in) width hexagon nut
KV10114400 (J-38365) Heated oxygen sensor wrench  NT636	Loosening or tightening heated oxygen sensor 2 a: 22 mm (0.87 in)

Commercial Service Tool

INFOID:000000006260597

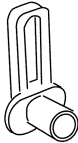
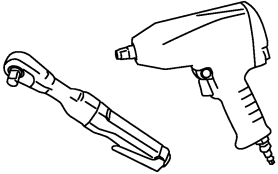
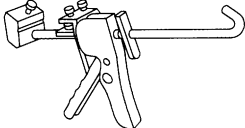
(Kent-Moore No.) Tool name	Description
(J-45488) Quick connector release  PBIC0198E	Removing fuel tube quick connectors in engine room
(—) Power tool  PBIC0190E	Loosening bolts and nuts
(—) Tube presser  NT052	Pressing the tube of liquid gasket



PREPARATION

< PREPARATION >

(Kent-Moore No.) Tool name	Description	
(—) Manual lift table caddy	Removing and installing engine	A EM C
(J-24239-01) Cylinder head bolt wrench	Loosening and tightening cylinder head bolt, and used with the angle wrench [SST: KV10112100 (BT8653-A)] a: 13 mm (0.51 in) dia. b: 12 mm (0.47 in) c: 10 mm (0.39 in)	D E
(—) 1. Compression tester 2. Adapter	Checking compression pressure	F G H
(—) Spark plug wrench	Removing and installing spark plug a: 14 mm (0.55 in)	I J
(—) Pulley holder	Removing and installing crankshaft pulley	K L M
(—) Valve seat cutter set	Finishing valve seat dimensions	N O
(—) Piston ring expander	Removing and installing piston ring	P

PREPARATION

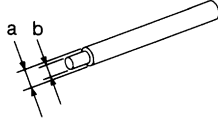
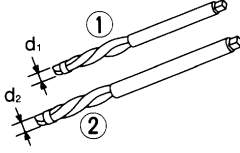
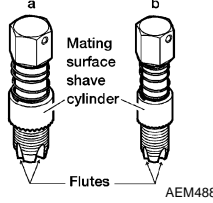
< PREPARATION >

(Kent-Moore No.) Tool name	Description
(—) Valve guide drift  NT015	Removing and installing valve guide Intake and Exhaust: a: 9.5 mm (0.374 in) dia. b: 5.5 mm (0.217 in) dia.
(—) Valve guide reamer  NT016	(1): Reaming valve guide inner hole (2): Reaming hole for oversize valve guide Intake and Exhaust: d1: 6.0 mm (0.236 in) dia. d2: 10.2 mm (0.402 in) dia.
a: (J-43897-18) b: (J-43897-12) Oxygen sensor thread cleaner  AEM488	Reconditioning the exhaust system threads before installing a new air fuel ratio sensor and heated oxygen sensor (Use with anti-seize lubricant shown below.) a: J-43897-18 [18 mm (0.71 in) dia.] for zirconia heated oxygen sensor and air fuel ratio sensor b: J-43897-12 [12 mm (0.47 in) dia.] for titania heated oxygen sensor
(—) Anti-seize lubricant (Permatex 133AR or equivalent meeting MIL specification MIL-A-907)  AEM489	Lubricating air fuel ratio sensor and oxygen sensor threads cleaning tool when reconditioning exhaust system threads

DRIVE BELT

< PERIODIC MAINTENANCE >

PERIODIC MAINTENANCE

DRIVE BELT

Exploded View

INFOID:000000006260598

A

EM

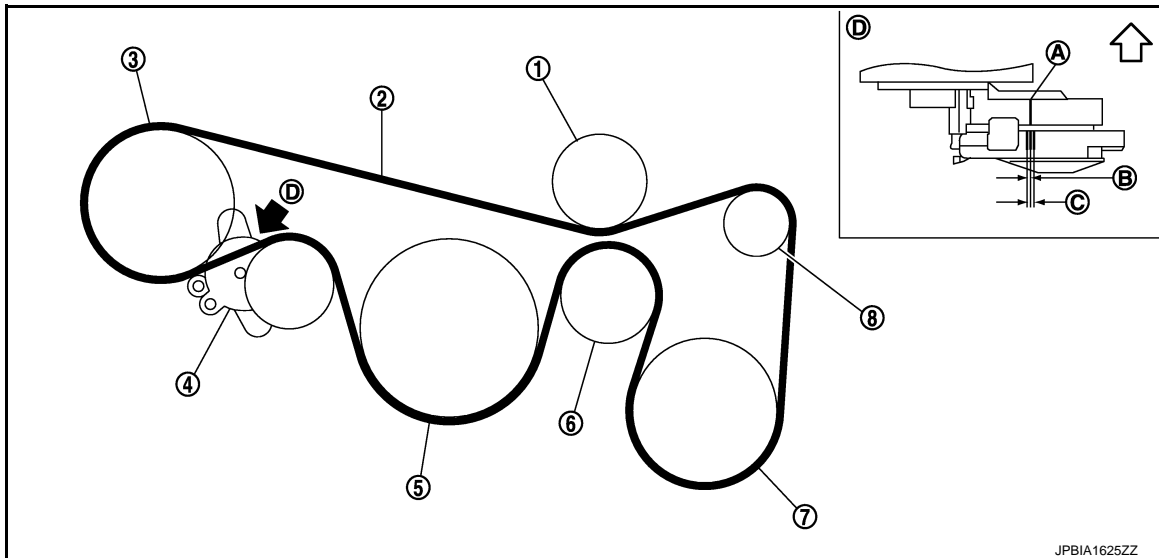

- | | | |
|------------------------------|---|----------------------------|
| 1. Idler pulley | 2. Drive belt | 3. Power steering oil pump |
| 4. Drive belt auto-tensioner | 5. Crankshaft pulley | 6. Idler pulley |
| 7. A/C compressor | 8. Alternator | |
| A. Indicator | B. Range when new drive belt is installed | C. Possible use range |
| D. View D | | |
- ↶ : Engine front

C

D

E

F

G

H

I

J

Checking

INFOID:000000006260599

WARNING:

Be sure to perform the this step when engine is stopped.

- Check that the indicator (A) of drive belt auto-tensioner is within the possible use range (C).

K

L

M

N

O

P

NOTE:

- Check the drive belt auto-tensioner indication when the engine is cold.
- When new drive belt is installed, the indicator should be within the range (B) in the figure.
- Visually check entire drive belt for wear, damage or cracks.
- If the indicator is out of the possible use range or belt is damaged, replace drive belt.

Tension Adjustment

INFOID:000000006260600

Refer to [EM-146. "Drive Belt"](#).

Removal and Installation

INFOID:000000006260601

REMOVAL

1. Remove front wheel and tire (RH).
2. Remove splash guard (RH). Refer to [EXT-23. "FENDER PROTECTOR : Exploded View"](#).

DRIVE BELT

< PERIODIC MAINTENANCE >

3. Hold the hexagonal part in center of drive belt auto-tensioner pulley with a box wrench securely. Then move the wrench handle in the direction of arrow (loosening direction of drive belt).

CAUTION:

- Avoid placing hand in a location where pinching may occur if the holding tool accidentally comes off.
- Never loosen the hexagonal part in center of drive belt auto-tensioner pulley (Never turn it counterclockwise). If turned counterclockwise, the complete drive belt auto-tensioner must be replaced as a unit, including the pulley.

4. Insert a rod approximately 6 mm (0.24 in) in diameter such as short-length screwdriver into the hole (A) of the retaining boss to fix drive belt auto-tensioner pulley.
5. Loosen drive belt from water pump pulley in sequence, and remove it.

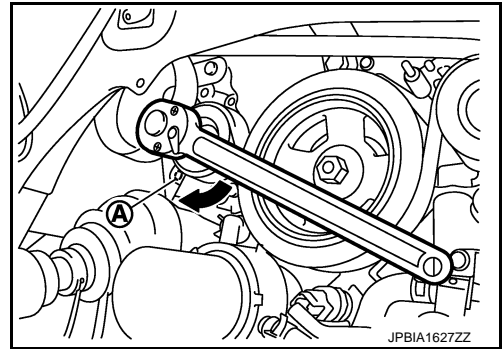

INSTALLATION

1. Hold the hexagonal part in center of drive belt auto-tensioner pulley with a box wrench securely. Then move the wrench handle in the direction of arrow (loosening direction of drive belt).

CAUTION:

- Avoid placing hand in a location where pinching may occur if the holding tool accidentally comes off.
- Never loosen the hexagonal part in center of drive belt auto-tensioner pulley (Never turn it counterclockwise). If turned counterclockwise, the complete drive belt auto-tensioner must be replaced as a unit, including the pulley.

2. Insert a rod approximately 6 mm (0.24 in) in diameter such as short-length screwdriver into the hole (A) of retaining boss to fix drive belt auto-tensioner pulley.
3. Hook drive belt onto all pulleys except for drive belt auto-tensioner pulley, and then onto drive belt auto-tensioner pulley finally.

CAUTION:

- Confirm drive belt is completely set to pulleys.
- Check for engine oil, working fluid and engine coolant are not adhered to drive belt and each pulley groove.

4. Release drive belt auto-tensioner, and apply tension to drive belt.
5. Turn crankshaft pulley clockwise several times to equalize tension between each pulley.
6. Confirm tension of drive belt at indicator is within the possible use range. Refer to [EM-17. "Exploded View"](#).

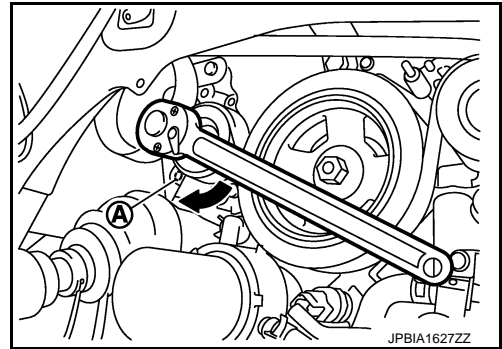

AIR CLEANER FILTER

< PERIODIC MAINTENANCE >

AIR CLEANER FILTER

Removal and Installation

INFOID:000000006260602

REMOVAL

1. Unhook air cleaner case (lower) side clips and lift up air cleaner case (upper).
2. Remove air cleaner filter and holder assembly from air cleaner case (lower).
3. Remove the air cleaner filter from the holder.

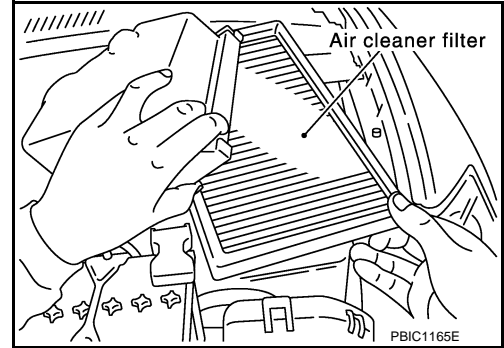

INSTALLATION

Note the following, and install in the reverse order of removal.

- Install the air cleaner filter by aligning the seal with the notch of air cleaner case.

A

EM

C

D

E

F

G

H

I

J

K

L

M

N

O

P

SPARK PLUG

< PERIODIC MAINTENANCE >

SPARK PLUG

Exploded View

INFOID:000000006260603

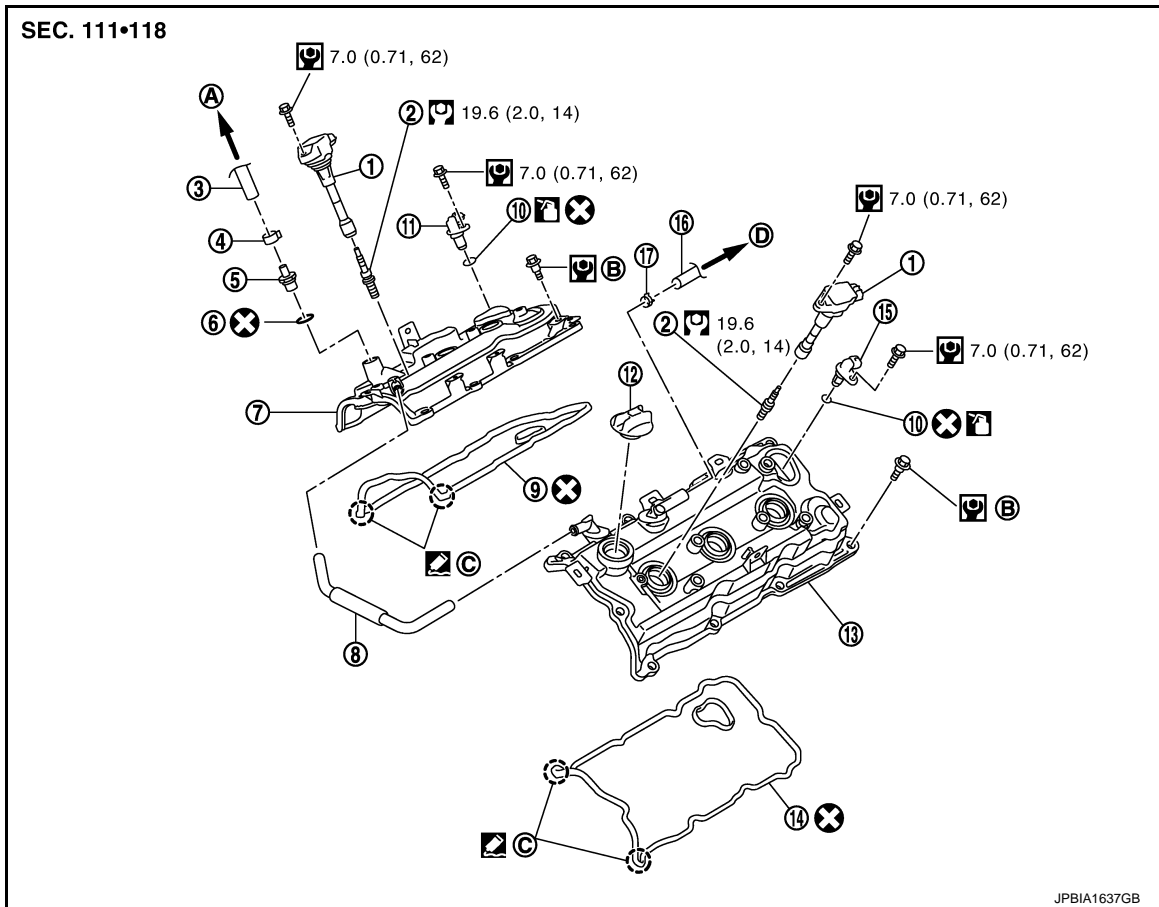

- | | | |
|---------------------------------|---|---|
| 1. Ignition coil | 2. Spark plug | 3. PCV hose |
| 4. Clamp | 5. PCV valve | 6. O-ring |
| 7. Rocker cover (bank 1) | 8. PCV hose | 9. Rocker cover gasket (bank 1) |
| 10. O-ring | 11. Camshaft position sensor (PHASE) (bank 1) | 12. Oil filler cap |
| 13. Rocker cover (bank 2) | 14. Rocker cover gasket (bank 2) | 15. Camshaft position sensor (PHASE) (bank 2) |
| 16. PCV hose | 17. Clamp | |
| A. To intake manifold collector | B. Comply with the assembly procedure when tightening. Refer to EM-54 | C. Camshaft bracket side |
| D. To air duct | | |

Refer to [GI-4, "Components"](#) for symbols in the figure.

Removal and Installation

INFOID:000000006260604

REMOVAL

1. Remove engine cover. Refer to [EM-29, "Exploded View"](#).
2. Remove air cleaner cases (upper and lower) and air duct assembly. Refer to [EM-31, "Exploded View"](#).
3. Remove electric throttle control actuator. Refer to [EM-33, "Exploded View"](#).
4. Remove intake manifold collector. Refer to [EM-33, "Exploded View"](#).
5. Remove ignition coil. Refer to [EM-54, "Exploded View"](#).

SPARK PLUG

< PERIODIC MAINTENANCE >

- Remove spark plug with a spark plug wrench (commercial service tool).

a : 14 mm (0.55 in)

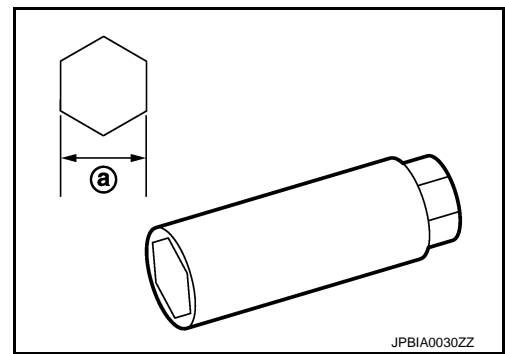

INSTALLATION

Install in the reverse order of removal.

Inspection

INFOID:000000006260605

INSPECTION AFTER REMOVAL

Use the standard type spark plug for normal condition.

Spark plug (Standard type) : Refer to [EM-147, "Spark Plug"](#).

CAUTION:

- Never drop or shock spark plug.
- Never use a wire brush for cleaning.
- If plug tip is covered with carbon, spark plug cleaner may be used.

Cleaner air pressure: Less than 588 kPa (6 kg/cm², 85 psi)

Cleaning time: Less than 20 seconds

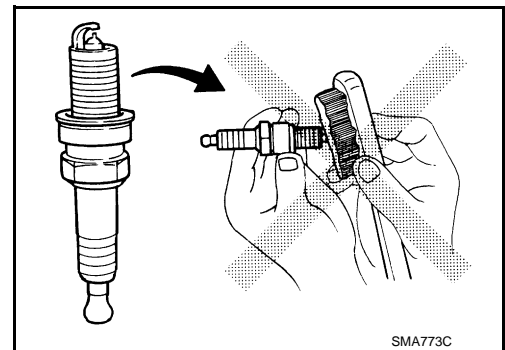

- Spark plug gap adjustment is not required between replacement intervals.
- Measure spark plug gap. When it exceeds the limit, replace spark plug even if it is within the specified replacement mileage. Refer to [EM-147, "Spark Plug"](#).

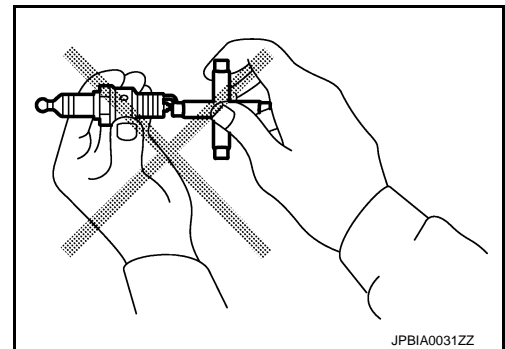

CAMSHAFT VALVE CLEARANCE

< PERIODIC MAINTENANCE >

CAMSHAFT VALVE CLEARANCE

Inspection and Adjustment

INFOID:00000006260606

INSPECTION

Perform inspection as follows after removal, installation or replacement of camshaft or valve-related parts, or if there is unusual engine conditions regarding valve clearance.

In cases of removing/installing or replacing camshaft and valve-related parts, or of unusual engine conditions due to changes in valve clearance (found malfunctions during starting, idling or causing noise), perform inspection as follows:

↔ : Engine front

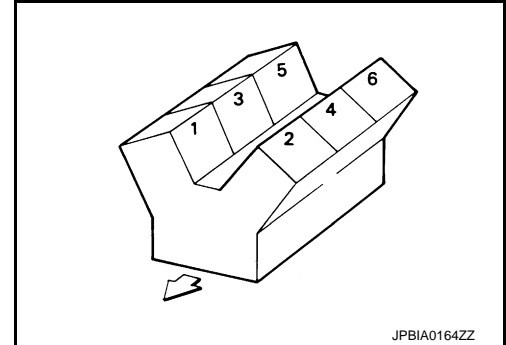

1. Remove rocker covers (bank 1 and bank 2). Refer to [EM-54. "Exploded View"](#).
2. Measure the valve clearance as follows:
 - a. Set No. 1 cylinder at TDC of its compression stroke.
 - Rotate crankshaft pulley clockwise to align timing mark (grooved line without color) (↻) with timing indicator.

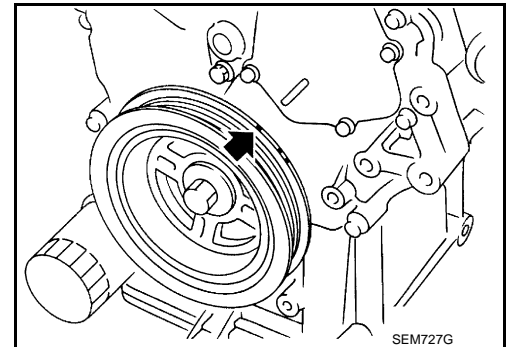

- Check that intake and exhaust cam nose on No. 1 cylinder (engine front side of bank 1) are located as shown in the figure.
- If not, turn crankshaft one revolution (360 degrees) and align as shown in the figure.

↔ : Engine front

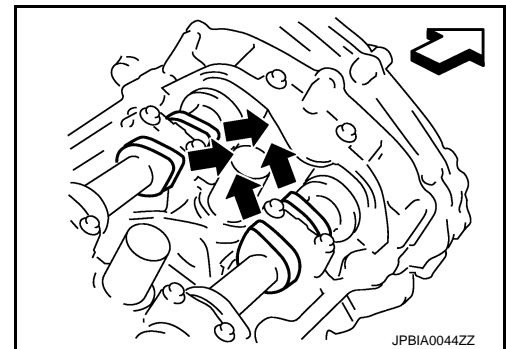

- b. Use a feeler gauge, measure the clearance between valve lifter and camshaft.

Valve clearance : Refer to [EM-147. "Camshaft"](#).

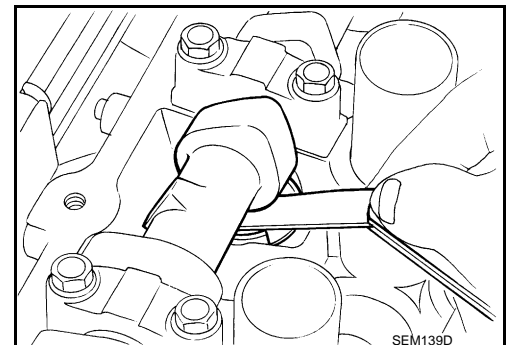

CAMSHAFT VALVE CLEARANCE

< PERIODIC MAINTENANCE >

- By referring to the figure, measure the valve clearances at locations marked "x" as shown in the table below (locations indicated in the figure).

← : Engine front

- No. 1 cylinder at compression TDC

Measuring position [bank 1 (A)]		No. 1 CYL.	No. 3 CYL.	No. 5 CYL.
No. 1 cylinder at compression TDC	EXH (C)		x (B)	
	INT (D)	x (E)		
Measuring position [bank 2 (H)]		No. 2 CYL.	No. 4 CYL.	No. 6 CYL.
No. 1 cylinder at compression TDC	INT (D)			x (F)
	EXH (C)	x (G)		

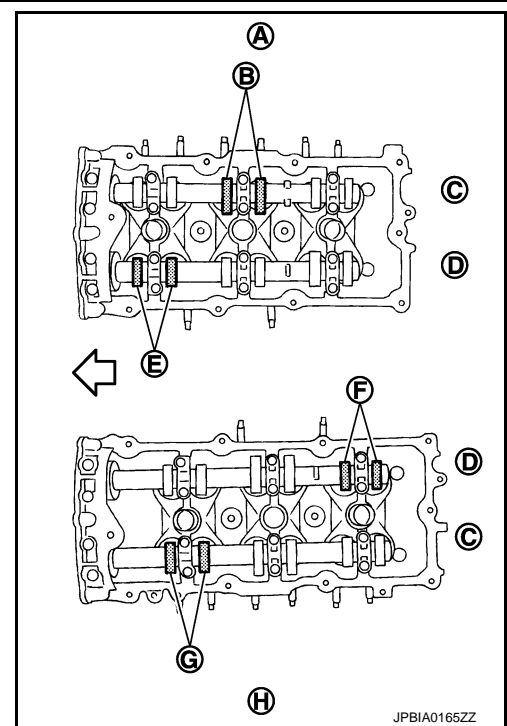

- c. Rotate crankshaft by 240 degrees clockwise (when viewed from engine front) to align No. 3 cylinder at TDC its compression stroke.

NOTE:

Mark a position 240 degrees (b) from a corner of the hexagonal part of crankshaft pulley mounting bolt as shown in the figure. Use the hexagonal part as a guide.

- 1 : Crankshaft pulley
- A : Paint mark

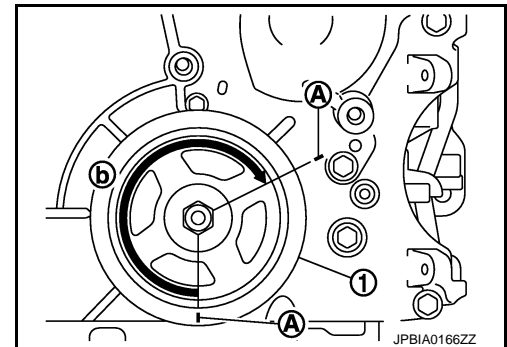

A
EM
C
D
E
F
G
H
I
J
K
L
M
N
O
P

CAMSHAFT VALVE CLEARANCE

< PERIODIC MAINTENANCE >

- By referring to the figure, measure the valve clearances at locations marked "×" as shown in the table below (locations indicated in the figure).

← : Engine front

- No. 3 cylinder at compression TDC

Measuring position [bank 1 (A)]		No. 1 CYL.	No. 3 CYL.	No. 5 CYL.
No. 3 cylinder at compression TDC	EXH (C)			× (B)
	INT (D)		× (E)	
Measuring position [bank 2 (H)]		No. 2 CYL.	No. 4 CYL.	No. 6 CYL.
No. 3 cylinder at compression TDC	INT (D)	× (F)		
	EXH (C)		× (G)	

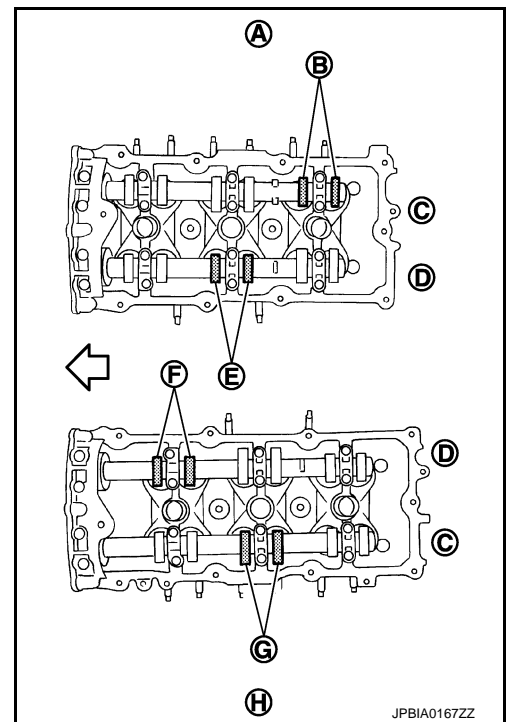

- d. Rotate crankshaft by 240 degrees clockwise (when viewed from engine front) to align No. 5 cylinder at TDC of compression stroke.

NOTE:

Mark a position 240 degrees (b) from a corner of the hexagonal part of crankshaft pulley mounting bolt as shown in the figure. Use the hexagonal part as a guide.

- 1 : Crankshaft pulley
- A : Paint mark

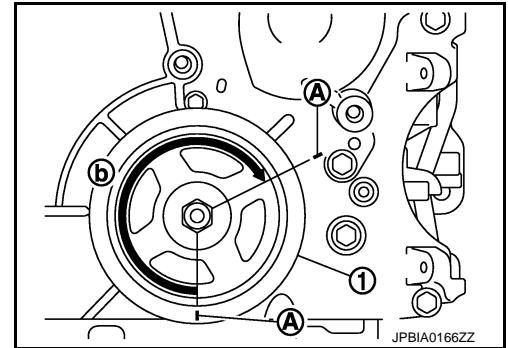

CAMSHAFT VALVE CLEARANCE

< PERIODIC MAINTENANCE >

- By referring to the figure, measure the valve clearances at locations marked "x" as shown in the table below (locations indicated in the figure).

← : Engine front

- No. 5 cylinder at compression TDC

Measuring position [bank 1 (A)]		No. 1 CYL.	No. 3 CYL.	No. 5 CYL.
No. 5 cylinder at compression TDC	EXH (C)	x (B)		
	INT (D)			x (E)
Measuring position [bank 2 (H)]		No. 2 CYL.	No. 4 CYL.	No. 6 CYL.
No. 5 cylinder at compression TDC	INT (D)		x (F)	
	EXH (C)			x (G)

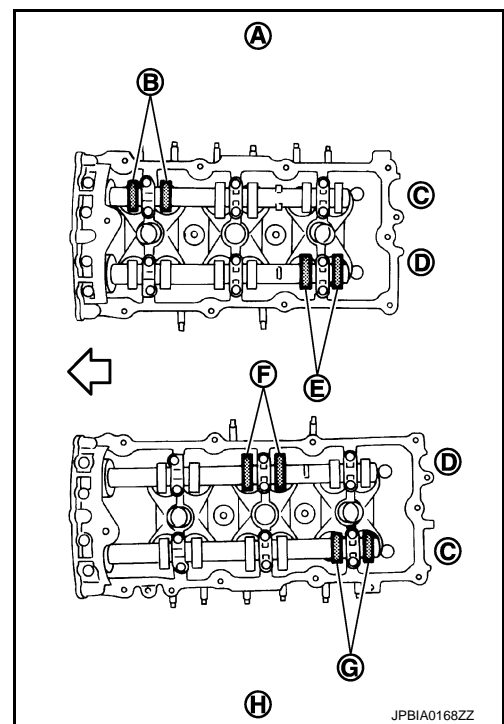

- Perform adjustment if the measured value is out of the standard. Refer to "ADJUSTMENT".

ADJUSTMENT

- Perform adjustment depending on selected head thickness of valve lifter.
 - Measure the valve clearance. Refer to "INSPECTION".
 - Remove camshaft. Refer to [EM-98. "Exploded View"](#).
 - Remove valve lifters at the locations that are out of the standard.
 - Measure the center thickness of the removed valve lifters with a micrometer (A).

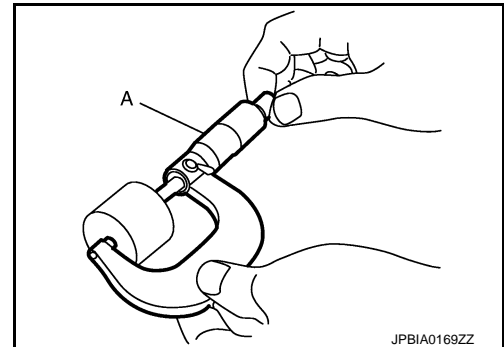

- Use the equation below to calculate valve lifter thickness for replacement.

Valve lifter thickness calculation: $t = t_1 + (C_1 - C_2)$

t = Valve lifter thickness to be replaced

t₁ = Removed valve lifter thickness

C₁ = Measured valve clearance

C₂ = Standard valve clearance:

Intake : 0.30 mm (0.012 in)

Exhaust : 0.33 mm (0.013 in)

CAMSHAFT VALVE CLEARANCE

< PERIODIC MAINTENANCE >

- Thickness of new valve lifter can be identified by stamp marks on the reverse side (inside the cylinder).
Stamp mark 788P indicates 7.88 mm (0.3102 in) in thickness.

A : Stamp

B : Thickness of valve lifter

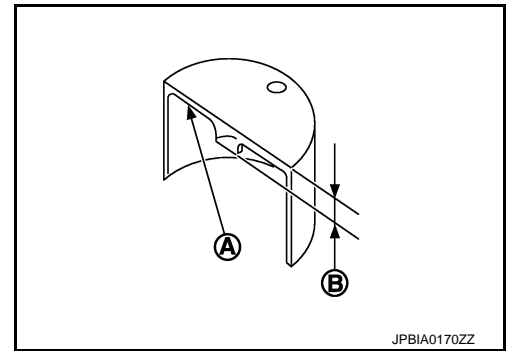

Available thickness of valve lifter: 27 sizes with range 7.88 to 8.40 mm (0.3102 to 0.3307 in) in steps of 0.02 mm (0.0008 in) (when manufactured at factory). Refer to [EM-147, "Camshaft"](#).

6. Install selected valve lifter.
7. Install camshaft. Refer to [EM-98, "Exploded View"](#).
8. Manually turn crankshaft pulley a few turns.
9. Check that the valve clearances for cold engine are within the specifications by referring to the specified values.
10. Install all removal parts in the reverse order of removal.
11. Warm up the engine, and check for unusual noise and vibration.

COMPRESSION PRESSURE

< PERIODIC MAINTENANCE >

COMPRESSION PRESSURE

Inspection

INFOID:000000006260607

1. Warm up engine thoroughly. Then, stop it.
2. Release fuel pressure. Refer to [EC-546, "Inspection"](#).
3. Disconnect fuel pump fuse to avoid fuel injection during measurement. Refer to [EC-36, "Component Parts Location"](#).
4. Remove engine cover. Refer to [EM-29, "Exploded View"](#).
5. Remove ignition coil and spark plug from each cylinder. Refer to [EM-54, "Exploded View"](#).
6. Connect engine tachometer (not required in use of CONSULT-III).
7. Install compression gauge with an adapter (commercial service tool) onto spark plug hole.

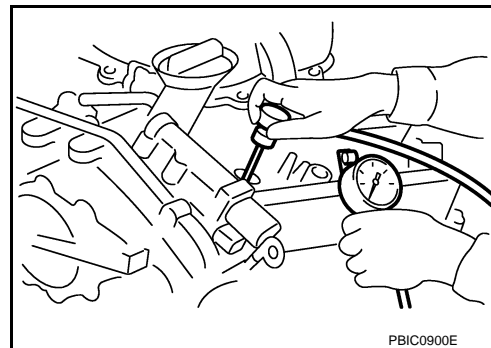

- Use the adapter whose picking up end inserted to spark plug hole is smaller than 20 mm (0.79 in) in diameter. Otherwise, it may be caught by cylinder head during removal.

a : 20 mm (0.79 in)

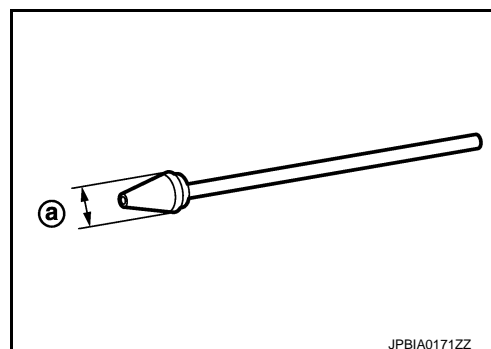

8. With accelerator pedal fully depressed, turn ignition switch to "START" for cranking. When the gauge pointer stabilizes, read the compression pressure and the engine rpm. Perform these steps to check each cylinder.

Compression pressure : Refer to [EM-146, "General Specification"](#).

CAUTION:

Always use a fully charged battery to obtain the specified engine speed.

- If the engine speed is out of the specified range, check battery liquid for proper gravity. Check the engine speed again with normal battery gravity.
 - If compression pressure is below minimum value, check valve clearances and parts associated with combustion chamber (valve, valve seat, piston, piston ring, cylinder bore, cylinder head, cylinder head gasket). After the checking, measure compression pressure again.
 - If some cylinder has low compression pressure, pour small amount of engine oil into the spark plug hole of the cylinder to recheck it for compression.
 - If the added engine oil improves the compression, piston rings may be worn out or damaged. Check piston rings and replace if necessary.
 - If the compression pressure remains at low level despite the addition of engine oil, valves may be malfunctioning. Check valves for damage. Replace valve or valve seat accordingly.
 - If two adjacent cylinders have respectively low compression pressure and their compression remains low even after the addition of engine oil, cylinder head gaskets are leaking. In such a case, replace cylinder head gaskets.
9. After inspection is completed, install removed parts.

COMPRESSION PRESSURE

< PERIODIC MAINTENANCE >

10. Start the engine, and check that the engine runs smoothly.
11. Perform trouble diagnosis. If DTC appears, erase it. Refer to [EC-139, "Description"](#).

ENGINE COVER

< REMOVAL AND INSTALLATION >

REMOVAL AND INSTALLATION

ENGINE COVER

Exploded View

INFOID:000000006260608

A

EM

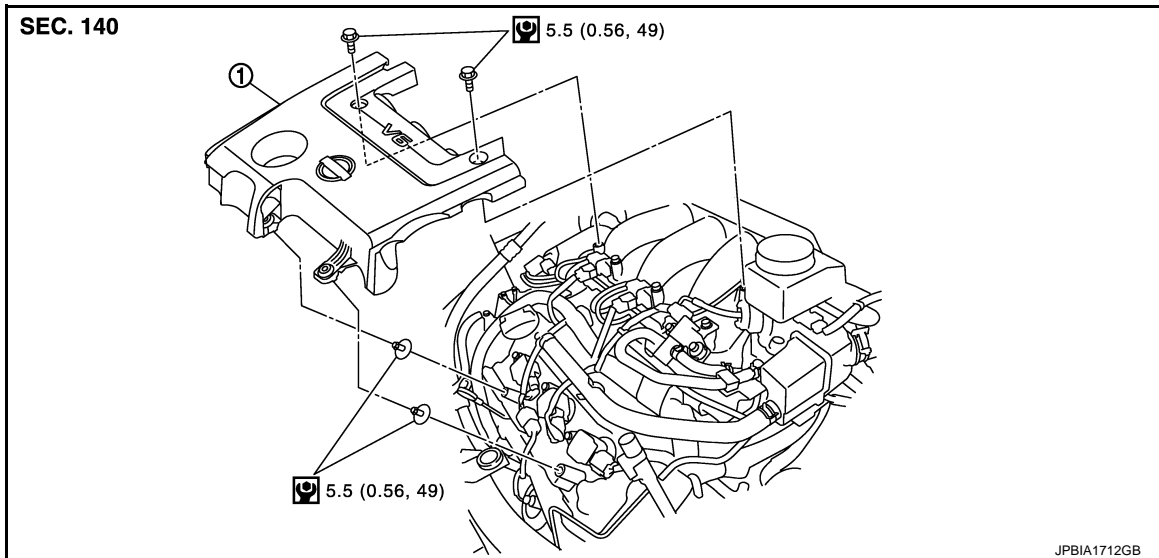

1. Engine cover

Refer to [GI-4, "Components"](#) for symbols in the figure.

Removal and Installation

INFOID:000000006260609

REMOVAL

1. Remove radiator core support covers (RH and LH) and air duct (inlet). Refer to [EM-31, "Exploded View"](#).
2. Remove engine cover mounting bolts (A) and (B).

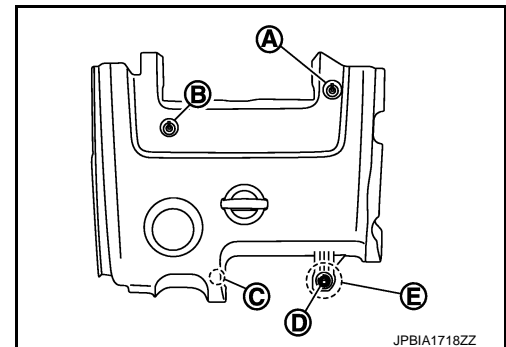

3. Draw and pull out engine cover from engine cover mounting bolts (C) and (D).

CAUTION:

Pull engine cover from mounting bolt (D) holding with hand the position (E) as shown in the figure.

4. Remove engine cover mounting bolts (C) and (D) if necessary.

INSTALLATION

Install in the reverse order of removal.

C

D

E

F

G

H

I

J

K

L

M

N

O

P

DRIVE BELT AUTO TENSIONER AND IDLER PULLEY

< REMOVAL AND INSTALLATION >

DRIVE BELT AUTO TENSIONER AND IDLER PULLEY

Exploded View

INFOID:000000006260610

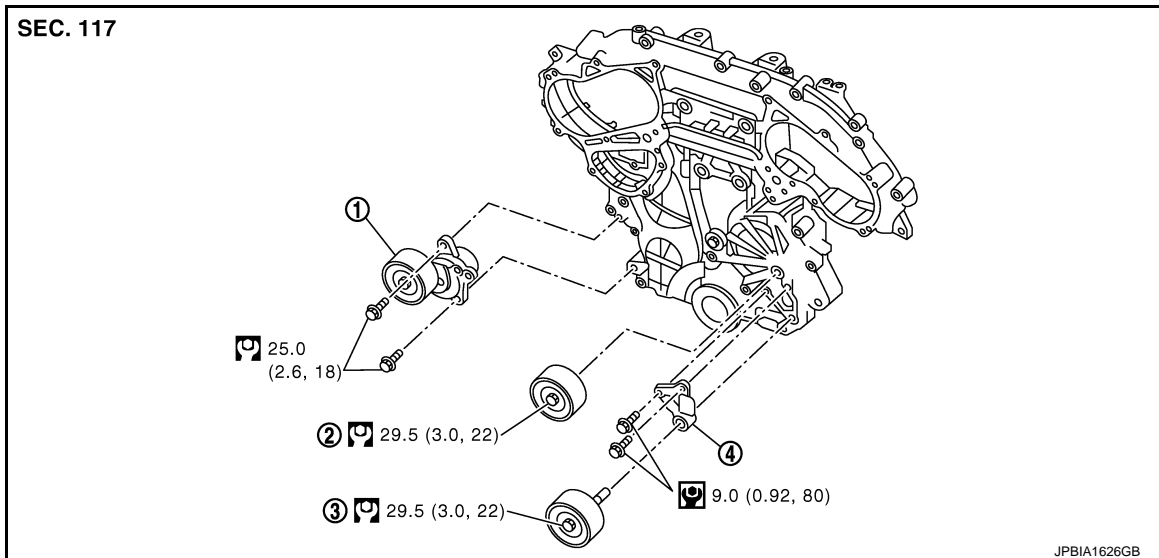

1. Drive belt auto-tensioner
2. Idler pulley
3. Idler pulley
4. Bracket

Refer to [GI-4, "Components"](#) for symbols in the figure.

Removal and Installation

INFOID:000000006260611

Removal

1. Remove drive belt. Refer to [EM-17, "Removal and Installation"](#).
 - Keep auto-tensioner pulley arm locked after drive belt is removed.
2. Remove auto-tensioner and idler pulley.
 - Keep auto-tensioner pulley arm locked to install or remove auto-tensioner.

Installation

Install in the reverse order of removal.

CAUTION:

If there is damage greater than peeled paint, replace drive belt auto-tensioner.

AIR CLEANER AND AIR DUCT

< REMOVAL AND INSTALLATION >

AIR CLEANER AND AIR DUCT

Exploded View

INFOID:000000006260612

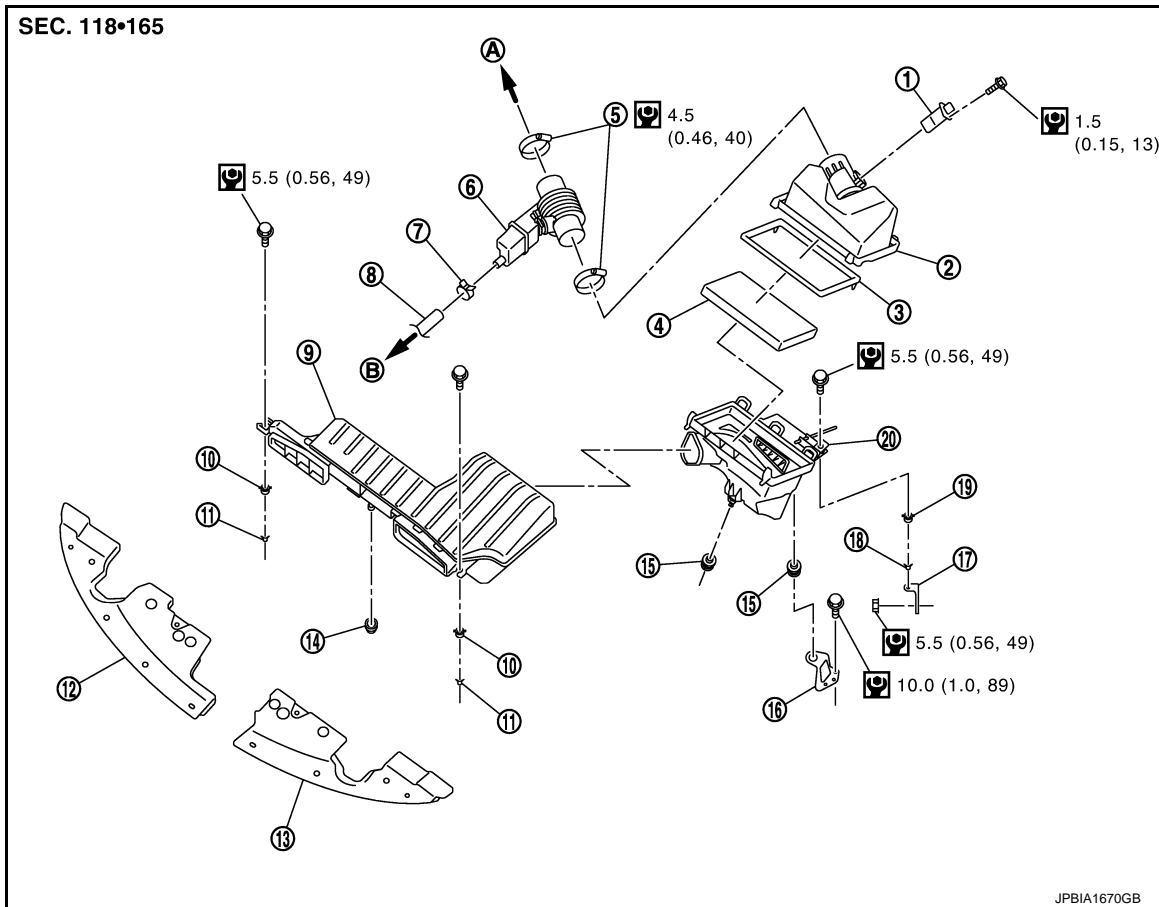

- | | | |
|--|------------------------------|--------------------------------------|
| 1. Mass air flow sensor | 2. Air cleaner case (upper) | 3. Holder |
| 4. Air cleaner filter | 5. Clamp | 6. Air duct assembly |
| 7. Clamp | 8. PCV hose | 9. Air duct (inlet) |
| 10. Grommet | 11. Collar | 12. Radiator core support cover (RH) |
| 13. Radiator core support cover (LH) | 14. Grommet | 15. Grommet |
| 16. Bracket | 17. Bracket | 18. Collar |
| 19. Grommet | 20. Air cleaner case (lower) | |
| A. To electric throttle control actuator | B. To rocker cover (bank 2) | |

Refer to [GI-4, "Components"](#) for symbols in the figure.

Removal and Installation

INFOID:000000006260613

REMOVAL

NOTE:

Mass air flow sensor is removable under the car-mounted condition.

- Remove radiator core support covers (RH and LH).
- Remove air duct (inlet).
- Disconnect harness connector from mass air flow sensor.
- Disconnect PCV hose.
- Remove air cleaner cases (upper and lower) with mass air flow sensor and air duct assembly disconnecting their joints.
 - Add mating marks if necessary for easier installation.

AIR CLEANER AND AIR DUCT

< REMOVAL AND INSTALLATION >

6. Remove mass air flow sensor from air cleaner case (upper), if necessary.

CAUTION:

Handle the mass air flow sensor with following cares.

- **Never shock the mass air flow sensor.**
- **Never disassemble the mass air flow sensor.**
- **Never touch the sensor of the mass air flow sensor.**

INSTALLATION

Note the following, and install in the reverse order of removal.

- Align marks. Attach each joint. Screw clamps firmly.

Inspection

INFOID:000000006260614

INSPECTION AFTER REMOVAL

Inspect air duct assembly for crack or tear.

- If anything found, replace air duct assembly.

INTAKE MANIFOLD COLLECTOR

< REMOVAL AND INSTALLATION >

INTAKE MANIFOLD COLLECTOR

Exploded View

INFOID:000000006260615

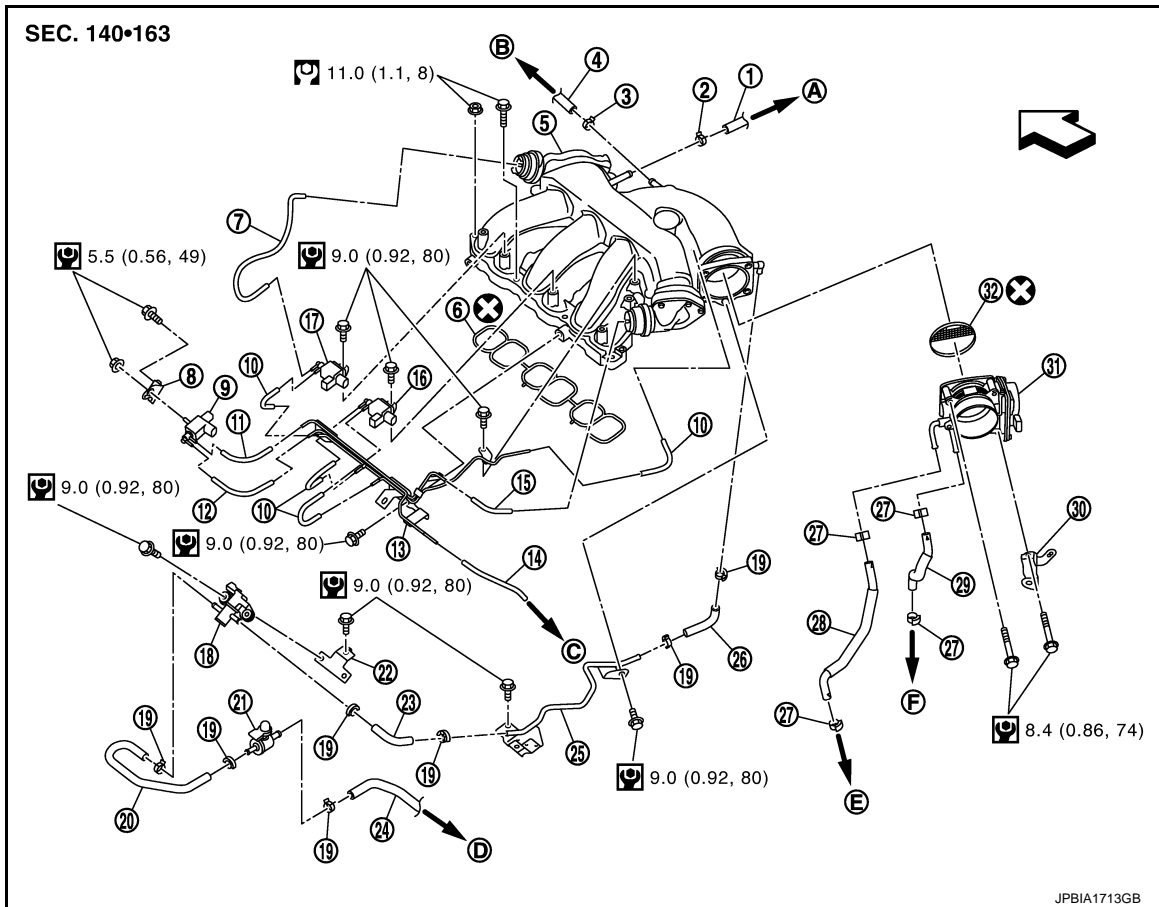

- | | | |
|--|-----------------------------------|--|
| 1. Vacuum hose | 2. Clamp | 3. Clamp |
| 4. PCV hose | 5. Intake manifold collector | 6. Gasket |
| 7. Vacuum hose | 8. Bracket | 9. Electronic controlled engine mount control solenoid valve |
| 10. Vacuum hose | 11. Vacuum hose | 12. Vacuum hose |
| 13. Vacuum gallery | 14. Vacuum hose | 15. Vacuum hose |
| 16. VIAS control solenoid valve 2 | 17. VIAS control solenoid valve 1 | 18. EVAP canister purge control solenoid valve |
| 19. Clamp | 20. EVAP hose | 21. Service port |
| 22. Bracket | 23. EVAP hose | 24. EVAP hose |
| 25. EVAP pipe | 26. EVAP hose | 27. Clamp |
| 28. Water hose | 29. Water hose | 30. Bracket |
| 31. Electric throttle control actuator | 32. Gasket | |
- A. To brake booster
 B. To rocker cover (bank 1)
 C. To vacuum tube
 D. To vacuum pipe
 E. To heater pipe
 F. To water outlet

↔ : Engine front

Refer to [GI-4. "Components"](#) for symbols in the figure.

Removal and Installation

INFOID:000000006260616

REMOVAL

WARNING:

INTAKE MANIFOLD COLLECTOR

< REMOVAL AND INSTALLATION >

To avoid the danger of being scalded, never drain engine coolant when the engine is hot.

1. Remove engine cover. Refer to [EM-29, "Exploded View"](#).
CAUTION:
Be careful not to damage or scratch engine cover.
2. Remove air cleaner cases (upper and lower) with mass air flow sensor and air duct assembly. Refer to [EM-31, "Exploded View"](#).
3. Drain engine coolant, or when water hoses are disconnected, attach plug to prevent engine coolant leakage. Refer to [CO-11, "Draining"](#).
CAUTION:
Perform this step when the engine is cold.
4. Remove front wiper arm and extension cowl top. Refer to [WW-117, "Exploded View"](#) and [EXT-20, "Exploded View"](#).
5. Disconnect water hoses from electric throttle control actuator.
 - When engine coolant is not drained from radiator, attach plug to water hoses to prevent engine coolant leakage.

6. Remove electric throttle control actuator as follows:
 - a. Disconnect harness connector.
 - b. Loosen mounting bolts in the reverse order as shown in the figure.

CAUTION:

- Handle carefully to avoid any shock to electric throttle control actuator.
- Never disassemble.

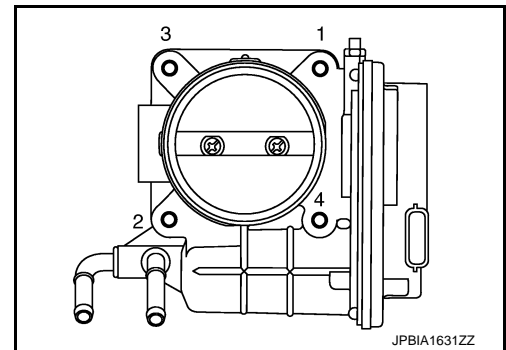

7. Remove the following parts:
 - Vacuum hose
 - PCV hose
 - High pressure piping from intake manifold: Refer to [ST-62, "Exploded View"](#).
 - Electronic controlled engine mount control solenoid valve
8. Disconnect EVAP hoses and harness connector from EVAP canister purge volume control solenoid valve.
9. Remove EVAP canister purge volume control solenoid valve and bracket assembly.
10. Remove VIAS control solenoid valve mounting bolts and vacuum gallery mounting bolts, and then move vacuum gallery.
 - Add mating marks if necessary for easier installation.
11. Loosen mounting nuts and bolts in the reverse order as shown in the figure, and remove intake manifold collector and gasket.

← : Engine front

CAUTION:

Cover engine openings to avoid entry of foreign materials.

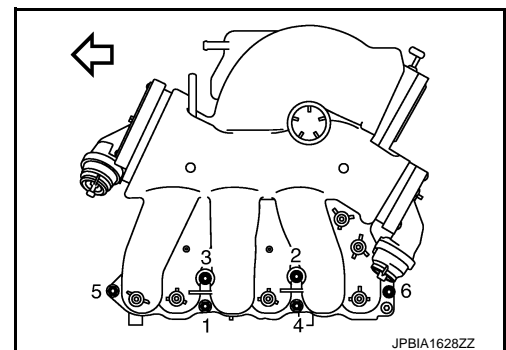

INSTALLATION

Note the following, and install in the reverse order of removal.

Intake Manifold Collector

INTAKE MANIFOLD COLLECTOR

< REMOVAL AND INSTALLATION >

Tighten mounting nuts and bolts in numerical order as shown in the figure.

↶ : Engine front

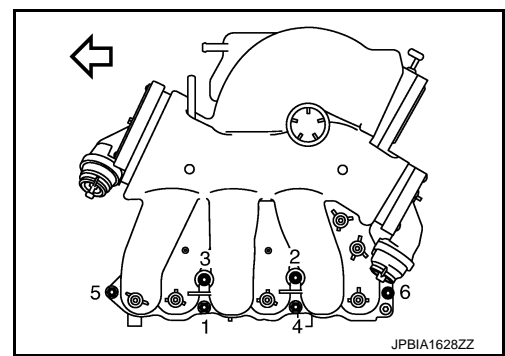

Electric Throttle Control Actuator

- Tighten mounting bolts in numerical order as shown in the figure.
- Perform the "Throttle Valve Closed Position Learning" when harness connector of electric throttle control actuator is disconnected. Refer to [EC-19, "THROTTLE VALVE CLOSED POSITION LEARNING : Description"](#).
- Perform the "Idle Air Volume Learning" and "Throttle Valve Closed Position Learning" when electric throttle control actuator is replaced. Refer to [EC-20, "IDLE AIR VOLUME LEARNING : Description"](#).

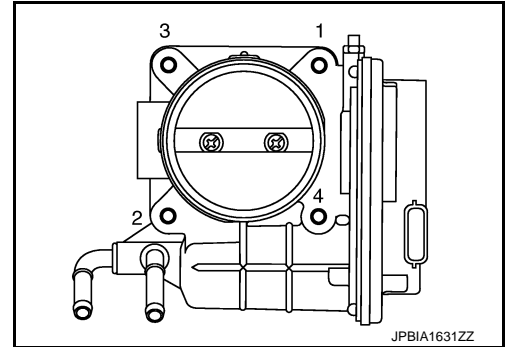

A

EM

C

D

E

F

G

H

I

J

K

L

M

N

O

P

INTAKE MANIFOLD

< REMOVAL AND INSTALLATION >

INTAKE MANIFOLD

Exploded View

INFOID:000000006260617

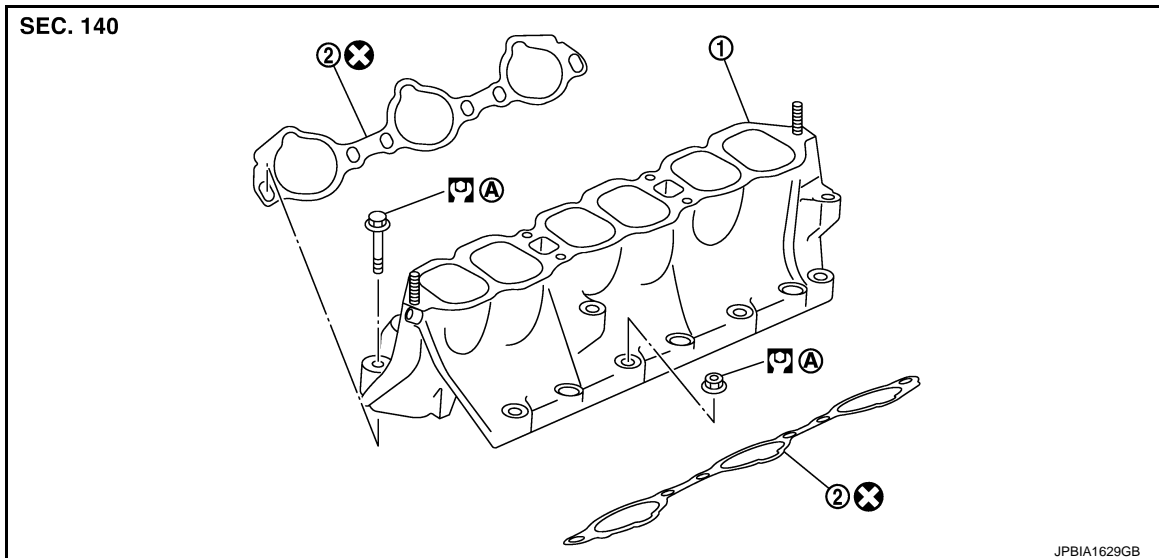

1. Intake manifold
2. Gasket

A. Comply with the assembly procedure when tightening. Refer to [EM-36](#)

Refer to [GI-4, "Components"](#) for symbols in the figure.

Removal and Installation

INFOID:000000006260618

REMOVAL

1. Release fuel pressure. Refer to [EC-546, "Inspection"](#).
2. Remove intake manifold collector. Refer to [EM-33, "Exploded View"](#).
3. Remove fuel tube and fuel injector assembly. Refer to [EM-49, "Exploded View"](#).
4. Loosen mounting nuts and bolts in the reverse order as shown in the figure to remove intake manifold with power tool.

← : Engine front

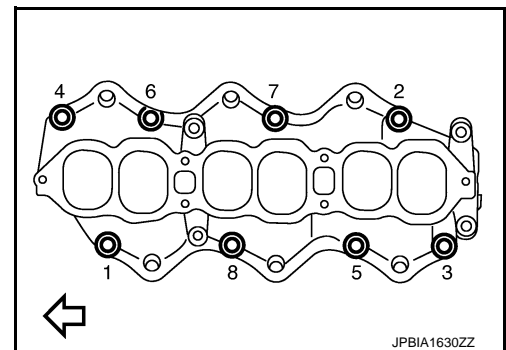

5. Remove gaskets.
CAUTION:
Cover engine openings to avoid entry of foreign materials.

INSTALLATION

Note the following, and install in the reverse order of removal.

Intake Manifold

- If stud bolts were removed, install them and tighten to the specified torque below.

: 10.8 N·m (1.1 kg·m, 8 ft·lb)

INTAKE MANIFOLD

< REMOVAL AND INSTALLATION >

- Tighten all mounting nuts and bolts to the specified torque in two or more steps in numerical order shown in the figure.

← : Engine front

 **1st step** : 7.4 N·m (0.75 kg·m, 5 ft·lb)

 **2nd step and after** : 25.5 N·m (2.6 kg·m, 19 ft·lb)

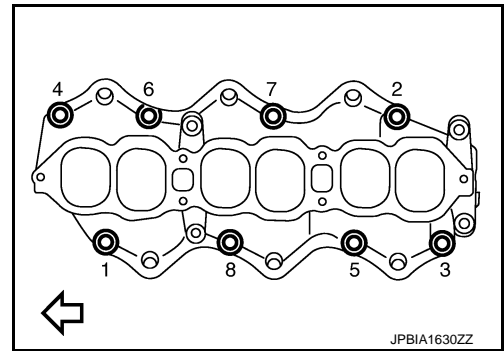

INFOID:000000006260619

Inspection

INSPECTION AFTER REMOVAL

Surface Distortion

- Check the surface distortion of the intake manifold mating surface with a straightedge (A) and a feeler gauge (B).

Limit : Refer to [EM-147, "Intake Manifold"](#).

- If it exceeds the limit, replace intake manifold.

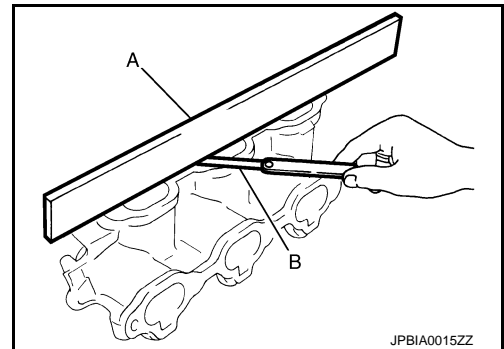

EXHAUST MANIFOLD AND THREE WAY CATALYST

< REMOVAL AND INSTALLATION >

EXHAUST MANIFOLD AND THREE WAY CATALYST

Exploded View

INFOID:000000006260620

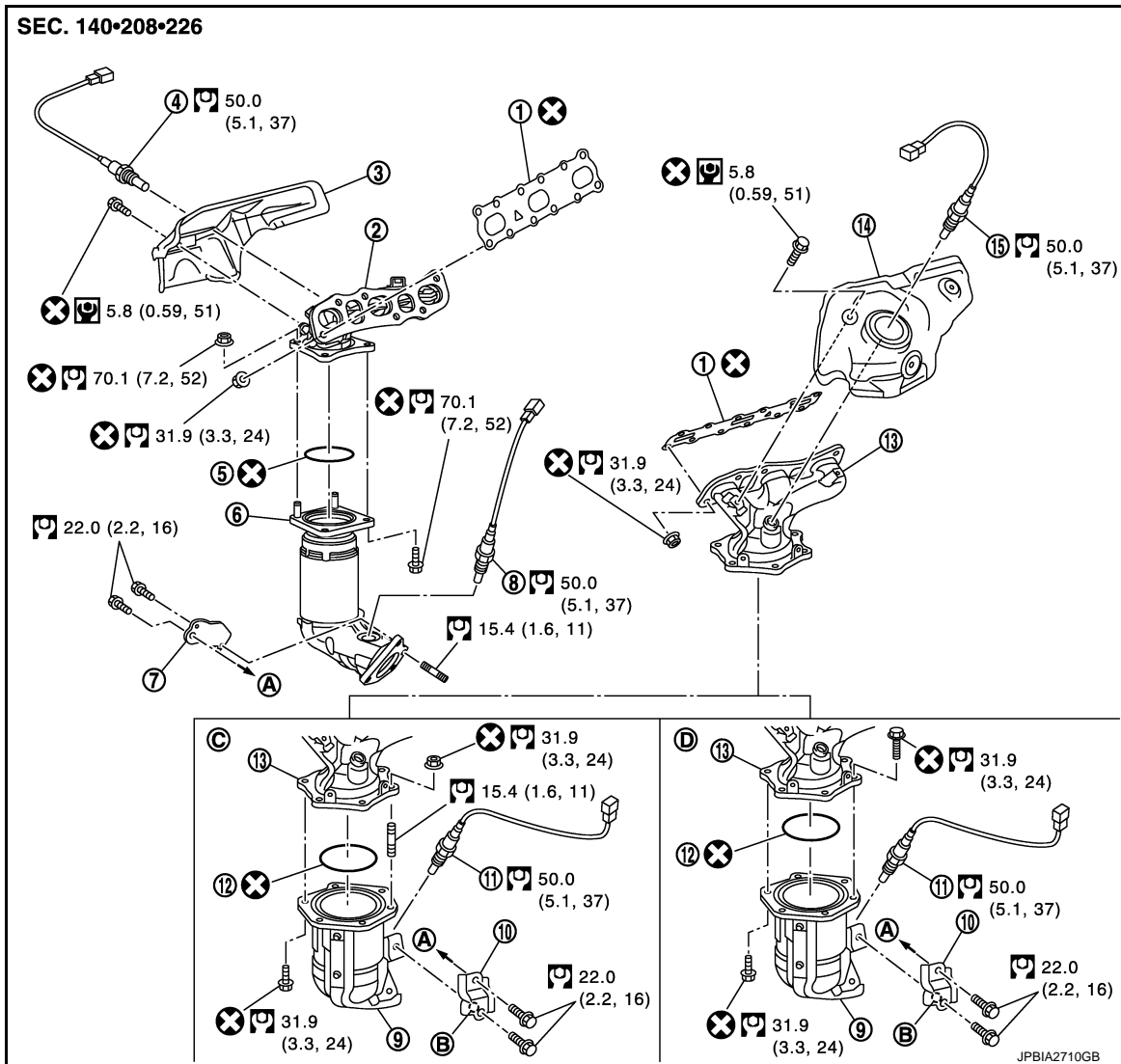

- | | | |
|---|-------------------------------------|--|
| 1. Gasket | 2. Exhaust manifold (bank 1) | 3. Exhaust manifold cover (bank 1) |
| 4. Air fuel ratio sensor 1 (bank 1) | 5. Ring gasket | 6. Three way catalyst (bank 1) |
| 7. Three way catalyst support (bank 1) | 8. Heated oxygen sensor 2 (bank 1) | 9. Three way catalyst (bank 2) |
| 10. Three way catalyst support (bank 2) | 11. Heated oxygen sensor 2 (bank 2) | 12. Ring gasket |
| 13. Exhaust manifold (bank 2) | 14. Exhaust manifold cover (bank 2) | 15. Air fuel ratio sensor 1 (bank 2) |
| A. To oil pan (upper) | B. Upper mark | C. Stud bolt and flange bolt type (bank 2) |
| D. Flange bolt type (bank 2) | | |

Refer to [GI-4, "Components"](#) for symbols in the figure.

Removal and Installation

INFOID:000000006260621

REMOVAL

WARNING:

Perform the work when the exhaust and cooling system have completely cooled down.

1. Remove following parts:

EXHAUST MANIFOLD AND THREE WAY CATALYST

< REMOVAL AND INSTALLATION >

- Radiator core support covers (RH and LH), air duct (inlet), air cleaner case (upper) with mass air flow sensor and air duct assembly: Refer to [EM-31, "Exploded View"](#).
 - Engine cover: Refer to [EM-29, "Exploded View"](#).
 - Front wiper arm: Refer to [WW-117, "Exploded View"](#).
 - Extension cowl top: Refer to [EXT-20, "Exploded View"](#).
2. Remove exhaust front tube. Refer to [EX-5, "Exploded View"](#).

3. Disconnect harness connector and remove air fuel ratio sensor 1 on both banks with the heated oxygen sensor wrench [SST: KV10117100 (J-3647-A)] (B).
 - Put marks to identify installation positions of each air fuel ratio sensor 1.

CAUTION:

- Discard air fuel ratio sensor 1 which has been dropped from a height of more than 0.5 m (19.7 in) onto a hard surface such as a concrete floor; use a new one.
- Before installing new air fuel ratio sensor 1, clean exhaust system threads using oxygen sensor thread cleaner (commercial service tool) and approved Antiseize lubricant (commercial service tool).

NOTE:

Figure is shown as an example of bank 2 (A).

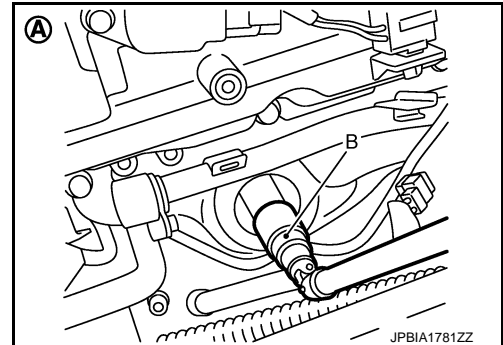

4. Disconnect harness connector and remove heated oxygen sensor 2 on both banks with the heated oxygen sensor wrench [SST: KV10114400 (J-38365)] (B).

A : Bank 2

C : Bank 1

- Put marks to identify installation positions of each heated oxygen sensor 2.

CAUTION:

- Discard heated oxygen sensor 2 which has been dropped from a height of more than 0.5 m (19.7 in) onto a hard surface such as a concrete floor; use a new one.
- Before installing new heated oxygen sensor 2, clean exhaust system threads using oxygen sensor thread cleaner (commercial service tool) and approved Antiseize lubricant (commercial service tool).

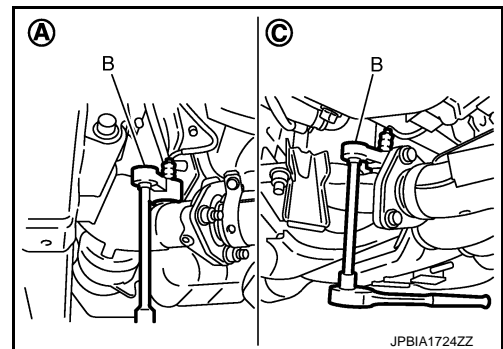

5. Remove exhaust manifold covers (bank 1 and bank 2).
6. Remove three way catalyst support mounting bolts (bank 1 and bank 2).
7. Remove three way catalysts by loosening bolts first and then removing nuts. (Stud bolt and flange bolt type)

CAUTION:

Handle carefully to avoid any shock to three way catalyst.

EXHAUST MANIFOLD AND THREE WAY CATALYST

< REMOVAL AND INSTALLATION >

8. Loosen mounting nuts in the reverse order as shown in the figure to remove exhaust manifolds (bank 1 and bank 2).

- A : Bank 1
 B : Bank 2
 ⇐ : Engine front

NOTE:

Disregard No. 7 and 8 when loosening.

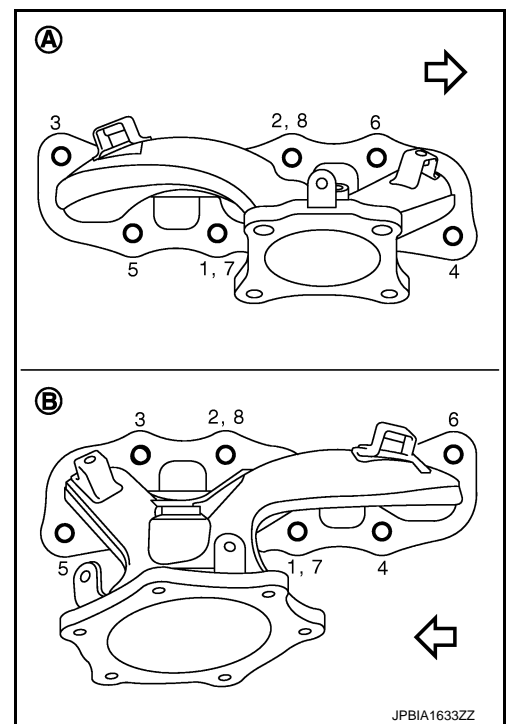

9. Remove gaskets.

CAUTION:

Cover engine openings to avoid entry of foreign materials.

INSTALLATION

Note the following, and install in the reverse order of removal.

Exhaust Manifold Gasket

Install in the direction indicated in the figure.

- A : Bank 1
 B : Triangle press
 C : Bank 2
 ⇐ : Engine front

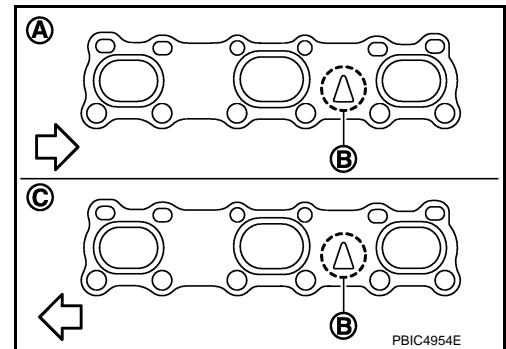

Exhaust Manifold

- If stud bolts were removed, install them and tighten to the torque specified below.

: 15.4 N·m (1.6 kg-m, 11 ft-lb)

EXHAUST MANIFOLD AND THREE WAY CATALYST

< REMOVAL AND INSTALLATION >

- Tighten mounting nuts in numerical order as shown in the figure.

A : Bank 1
 B : Bank 2
 : Engine front

NOTE:

No. 7 and 8 mean double tightening of nuts No. 1 and 2.

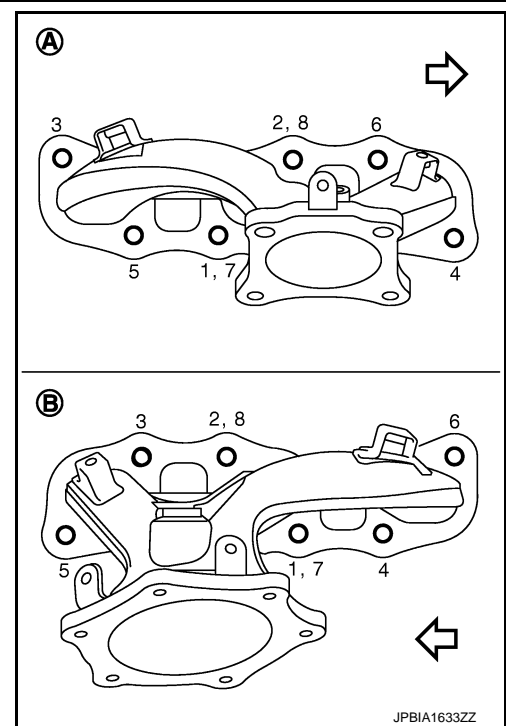

Three Way Catalyst (bank 2) Flange Bolt Type

1. Temporarily tighten upper side bolts (B) and lower side bolt (A) shown in the figure.

 : Engine front

2. Tighten the upper side bolts (B) shown in the figure. (specified torque)
3. Tighten all the lower side bolts [the other four except (B)]. (specified torque)

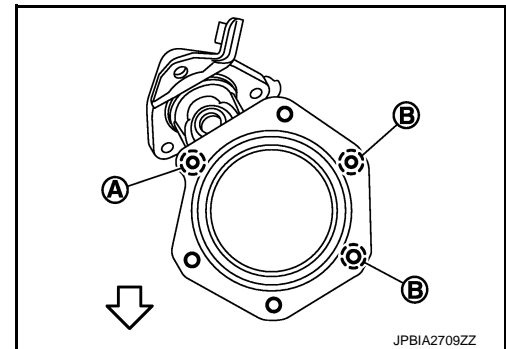

Three Way Catalyst Supports

1. Temporarily tighten three way catalyst support mounting bolts.
2. Tighten three way catalyst support mounting bolts to oil pan (upper).
3. Tighten three way catalyst support mounting bolts to three way catalyst.

Air Fuel Ratio Sensor 1 and Heated Oxygen Sensor 2

- Install air fuel ratio sensor 1 and heated oxygen sensor 2 in the original position.
- Install referring the following if the installation positions cannot be identified.

Glass tube color

Air fuel ratio sensor 1 : Black

Heated oxygen sensor 2 : White

CAUTION:

- Before installing a new air fuel ratio sensor and a new heated oxygen sensor, clean exhaust system threads using oxygen sensor thread cleaner (commercial service tool: J-43897-18 or J-43897-12) and apply anti-seize lubricant (commercial service tool).
- Never over torque air fuel ratio sensor and heated oxygen sensor. Doing so may cause damage to air fuel ratio sensor and heated oxygen sensor, resulting in "MIL" coming on.

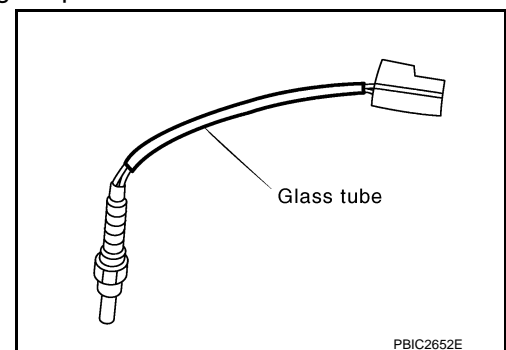

EXHAUST MANIFOLD AND THREE WAY CATALYST

< REMOVAL AND INSTALLATION >

- Prevent rust preventives from adhering to the sensor body.

Inspection

INFOID:000000006260622

INSPECTION AFTER REMOVAL

Surface Distortion

- Check the surface distortion of the exhaust manifold mating surface with a straightedge and a feeler gauge.

Limit : Refer to [EM-147, "Exhaust Manifold"](#).

- If it exceeds the limit, replace exhaust manifold.

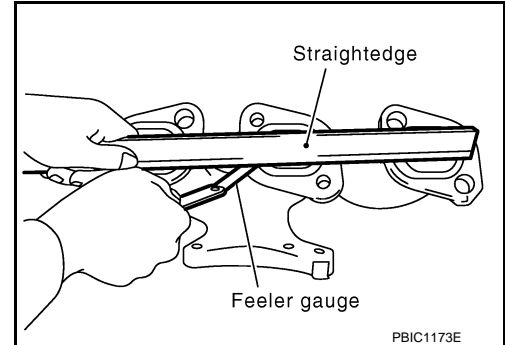

OIL PAN AND OIL STRAINER

< REMOVAL AND INSTALLATION >

OIL PAN AND OIL STRAINER

Exploded View

INFOID:000000006260623

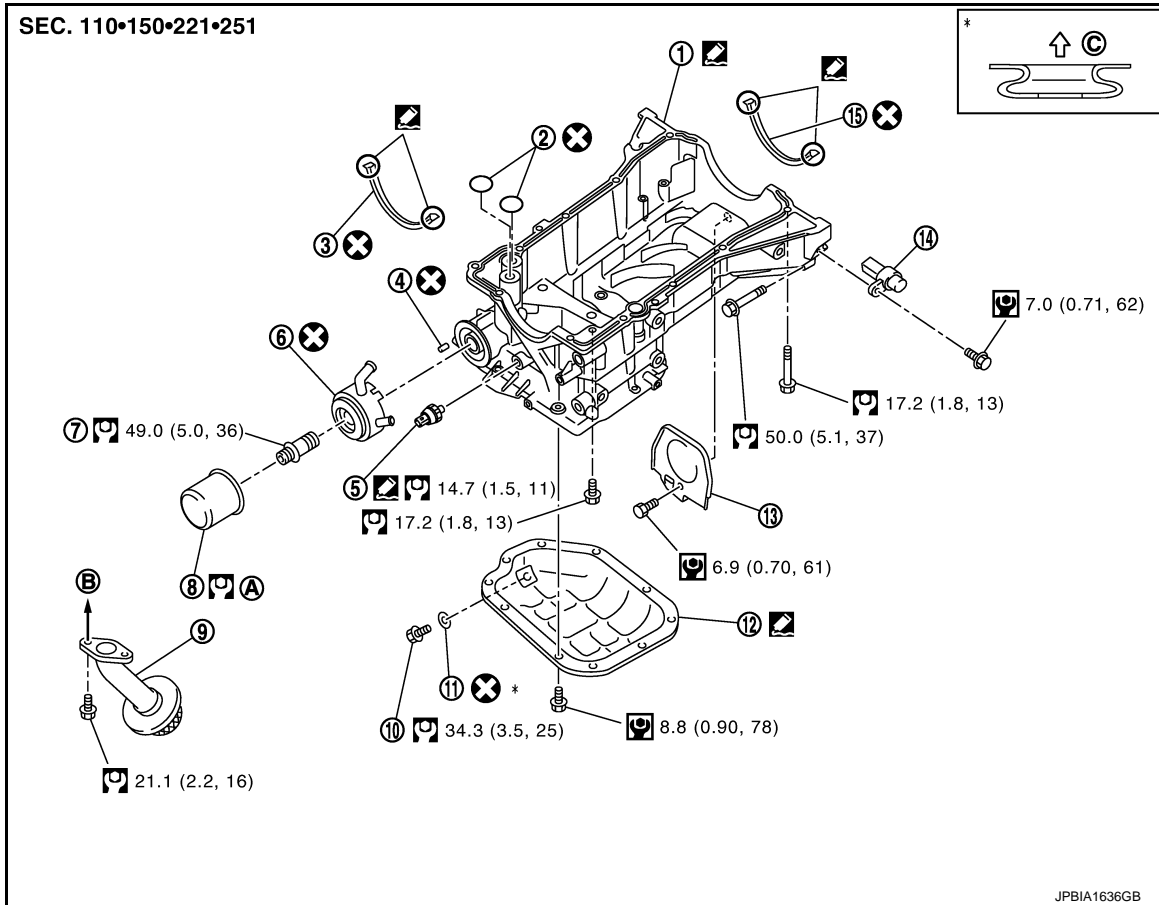

- | | | |
|-----------------------------------|--------------------------------------|---------------------------|
| 1. Oil pan (upper) | 2. O-ring | 3. Oil pan gasket (front) |
| 4. Relief valve | 5. Oil pressure switch | 6. Oil cooler |
| 7. Connector bolt | 8. Oil filter | 9. Oil strainer |
| 10. Drain plug | 11. Drain plug washer | 12. Oil pan (lower) |
| 13. Rear plate cover | 14. Crankshaft position sensor (POS) | 15. Oil pan gasket (rear) |
| A. Refer to LU-10 | B. To oil pump | C. Oil pan side |

Refer to [GI-4, "Components"](#) for symbols in the figure.

Removal and Installation

INFOID:000000006260624

REMOVAL

CAUTION:

To avoid the danger of being scalded, never drain engine oil when the engine is hot.

NOTE:

When removing oil pan (lower) or oil strainer only, take step 1 then step 19 and 20.

1. Drain engine oil. Refer to [LU-8, "Draining"](#).
CAUTION:
Never spill engine oil on drive belt.
2. Drain engine coolant. Refer to [CO-11, "Draining"](#).
CAUTION:
Never spill engine coolant on drive belt.
3. Remove following parts:
 - Front road wheel and tires (RH and LH).

OIL PAN AND OIL STRAINER

< REMOVAL AND INSTALLATION >

- Splash guard (RH and LH): Refer to [EXT-23, "FENDER PROTECTOR : Exploded View"](#).
 - Exhaust front tube: Refer to [EX-5, "Exploded View"](#).
 - Drive belt: Refer to [EM-17, "Removal and Installation"](#).
4. Remove A/C compressor with piping connected, and temporarily secure it to aside. Refer to [HA-37, "Exploded View"](#).
 5. Remove oil level gauge. Refer to [EM-111, "Exploded View"](#).
 6. Remove front drive shaft (RH). Refer to [FAX-17, "Exploded View"](#) (2WD models) or [FAX-43, "Exploded View"](#) (AWD models).
 7. Remove three way catalyst (bank 1 and bank 2) from exhaust manifolds (bank 1 and bank 2). Refer to [EM-38, "Exploded View"](#).
 8. Remove oil pressure switch.
 9. Remove oil filter. Refer to [LU-10, "Removal and Installation"](#).
 10. Remove oil cooler and water pipes. Refer to [LU-11, "Exploded View"](#).
 11. Support transaxle assembly with a suitable jack.

CAUTION:

When setting the transmission jack, be careful not to allow it to collide against the drain plug.

12. Support front suspension member with a suitable jack.
13. Remove engine mounting insulator (rear). Refer to [EM-72, "2WD : Exploded View"](#) (2WD models) or [EM-81, "AWD : Exploded View"](#) (AWD models).
14. Remove engine mounting insulator (LH) mounting bolts from transaxle. Refer to [EM-72, "2WD : Exploded View"](#) (2WD models) or [EM-81, "AWD : Exploded View"](#) (AWD models).
15. Remove rear torque rod through bolts from rear torque rod bracket. Refer to [EM-72, "2WD : Exploded View"](#) (2WD models) or [EM-81, "AWD : Exploded View"](#) (AWD models).
16. Remove member stay, front suspension member fixing bolts and nuts. Refer to [FSU-16, "Exploded View"](#).
17. Lower the jack for the front suspension member to the height.
18. Remove transfer assembly. Refer to [DLN-53, "Exploded View"](#) (AWD models).
19. Remove oil pan (lower) as follows:
 - a. Loosen mounting bolts in the reverse order as shown in the figure to remove.

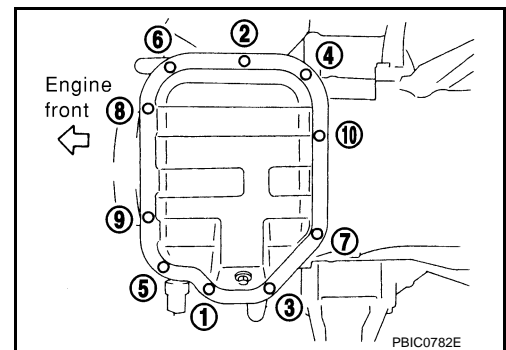

- b. Insert the seal cutter [SST: KV10111100 (J-37228)] (A) between oil pan (upper) and oil pan (lower).

CAUTION:

- **Be careful not to damage the mating surfaces.**
- **Never insert a screwdriver, this will damage the mating surfaces.**

- c. Slide the seal cutter by tapping on the side of tool with a hammer. Remove oil pan (lower).

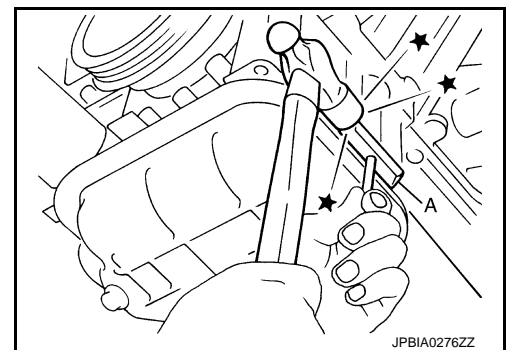

20. Remove oil strainer.

OIL PAN AND OIL STRAINER

< REMOVAL AND INSTALLATION >

21. Loosen mounting bolts in the reverse order as shown in the figure to remove.
- Insert the seal cutter [SST: KV10111100 (J-37228)] between oil pan (upper) and cylinder block. Slide seal cutter by tapping on the side of tool with a hammer. Remove oil pan (upper).

CAUTION:

- Be careful not to damage the mating surfaces.
- Never insert a screwdriver, this will damage the mating surfaces.

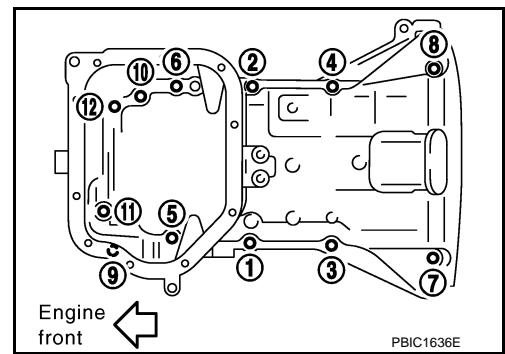

22. Remove O-rings (2) from bottom of cylinder block (1) and oil pump (3).

← : Engine front

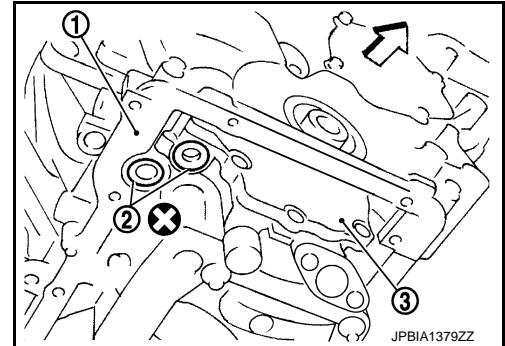

23. Remove oil pan gaskets (1).

A : Notch

B : Protrusion

← : Engine front

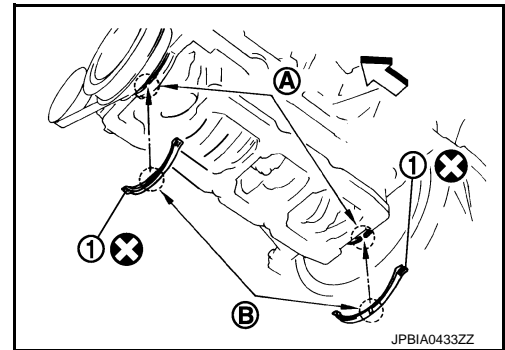

INSTALLATION

CAUTION:

Do not reuse O-rings and drain plug washer.

1. Install oil pan (upper) as follows:
- a. Use a scraper to remove old liquid gasket from mating surfaces.

CAUTION:

Never scratch or damage the mating surfaces when cleaning off old liquid gasket.

- Also remove old liquid gasket from mating surface of cylinder block.
- Remove old liquid gasket from the bolt holes and threads.

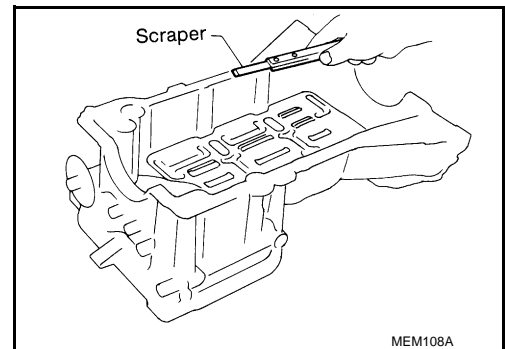

- b. Install new oil pan gaskets.

A
EM
C
D
E
F
G
H
I
J
K
L
M
N
O
P

OIL PAN AND OIL STRAINER

< REMOVAL AND INSTALLATION >

- Apply liquid gasket to new oil pan gaskets as shown in the figure.

C : Sealing point
 a : 15 mm (0.59 in)
 b : 5 mm (0.20 in)

Use Genuine RTV Silicone Sealant or equivalent. Refer to [GI-22, "Recommended Chemical Products and Sealants"](#).

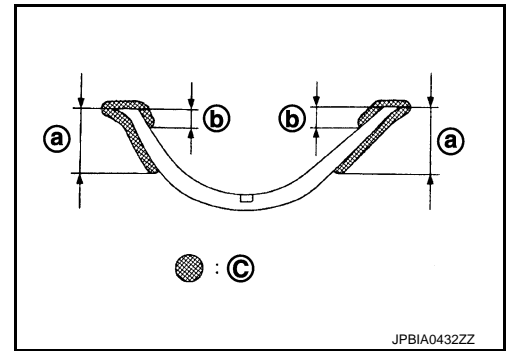

- To install, align protrusion (B) of oil pan gasket with notches (A) of front timing chain case and rear oil seal retainer.

⇐ : Engine front

- Install oil pan gasket (1) with smaller arc to front timing chain case side.

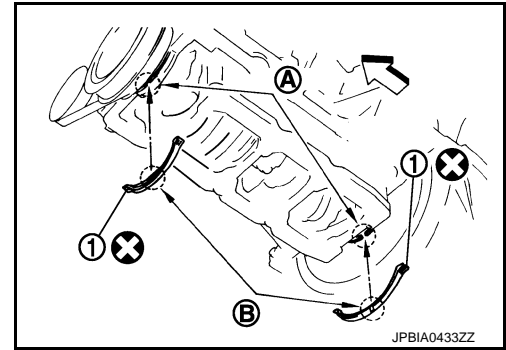

- c. Install new O-rings (2) on the bottom of cylinder block (1) and oil pump (3).

⇐ : Engine front

CAUTION:
Do not reuse O-rings.

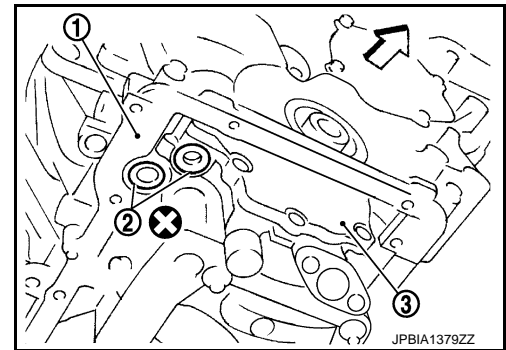

- d. Apply a continuous bead of liquid gasket with the tube presser (commercial service tool) to the cylinder block mating surface of oil pan (upper) to a limited portion as shown in the figure.

b : 35 mm (1.38 in)
 c : $\phi 3.5 - 4.5$ mm (0.138 - 0.177 in)

⇐ : Engine front

Use Genuine RTV Silicone Sealant or equivalent. Refer to [GI-22, "Recommended Chemical Products and Sealants"](#).

CAUTION:

- For bolt holes with ▲ marks (5 locations), apply liquid gasket outside the holes.
- Apply a bead of 4.5 to 5.5 mm (0.177 to 0.217 in) diameter to area (a).
- Attaching should be done within 5 minutes after coating.

- e. Install oil pan (upper).

CAUTION:

Install avoiding misalignment of both O-rings.

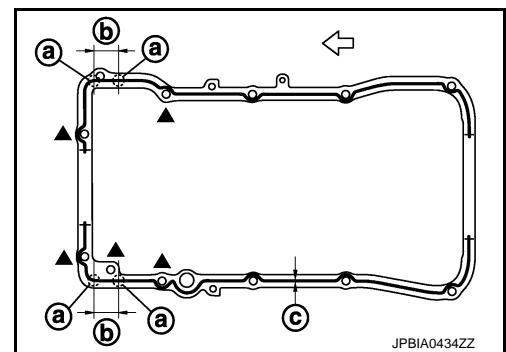

OIL PAN AND OIL STRAINER

< REMOVAL AND INSTALLATION >

- Tighten mounting bolts in numerical order as shown in the figure.
- There are three types of mounting bolts. Refer to the following for locating bolts.

M8 × 135 mm (5.31 in) : 11
M8 × 92 mm (3.62 in) : 5, 7, 8
M8 × 25 mm (0.98 in) : Except the above

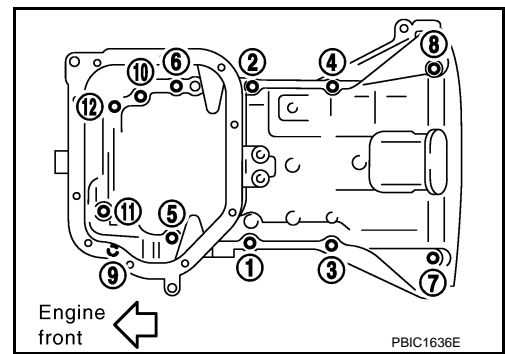

2. Install oil strainer to oil pump.
3. Install oil pan (lower) as follows:
- a. Use scraper (A) to remove old liquid gasket from mating surfaces.

- Remove old liquid gasket from the bolt holes and thread.

CAUTION:

Never scratch or damage the mating surfaces when cleaning off old liquid gasket.

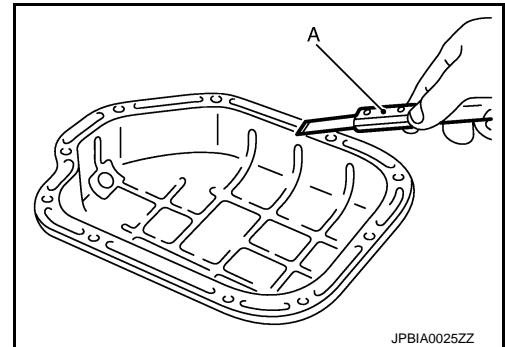

- b. Apply a continuous bead of liquid gasket with the tube presser (commercial service tool) (A) to the oil pan (lower) as shown in the figure.

b : $\phi 4.0 - 5.0$ mm (0.157 - 0.197 in)

Use Genuine RTV Silicone Sealant or equivalent. Refer to [GI-22. "Recommended Chemical Products and Sealants"](#).

CAUTION:

Attaching should be done within 5 minutes after coating.

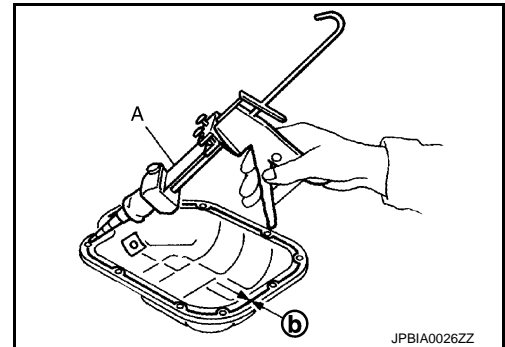

- c. Install oil pan (lower).
- Tighten mounting bolts in numerical order as shown in the figure.

4. Install oil pan drain plug.

CAUTION:

Do not reuse drain plug washer.

- Refer to the figure of components of former page for installation direction of drain plug washer. Refer to [EM-43. "Exploded View"](#).

5. Install in the reverse order of removal after this step.

NOTE:

At least 30 minutes after oil pan is installed, pour engine oil.

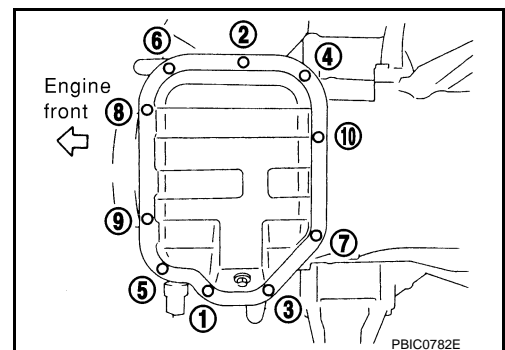

Inspection

INFOID:000000006260625

INSPECTION AFTER REMOVAL

Clean oil strainer if any object attached.

INSPECTION AFTER INSTALLATION

1. Check the engine oil level and adjust engine oil. Refer to [LU-7. "Inspection"](#).
2. Start engine, and check there is no leakage of engine oil.

OIL PAN AND OIL STRAINER

< REMOVAL AND INSTALLATION >

3. Stop engine and wait for 10 minutes.
4. Check the engine oil level again. Refer to [LU-7, "Inspection"](#).

FUEL INJECTOR AND FUEL TUBE

< REMOVAL AND INSTALLATION >

FUEL INJECTOR AND FUEL TUBE

Exploded View

INFOID:000000006260626

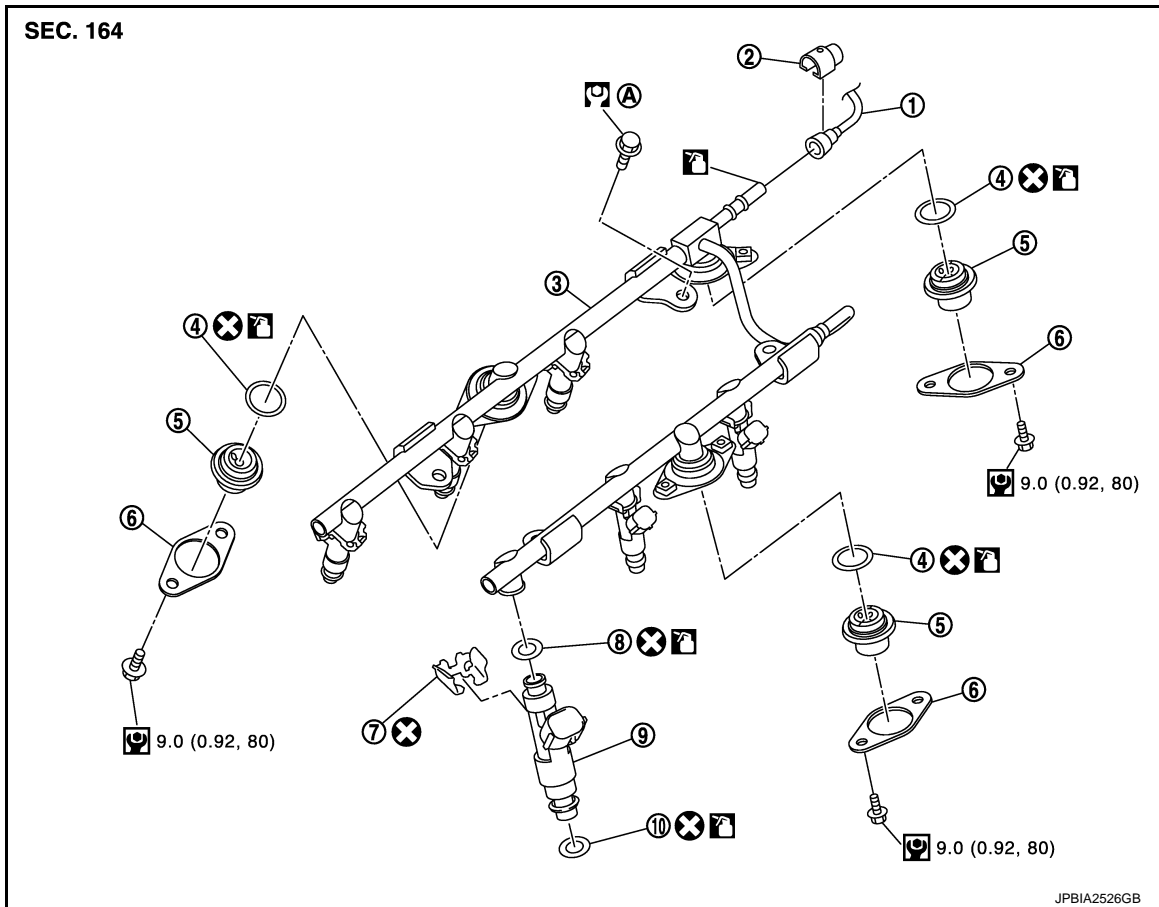

- | | | |
|--------------------|------------------------|--------------------|
| 1. Fuel feed hose | 2. Quick connector cap | 3. Fuel tube |
| 4. O-ring | 5. Fuel damper | 6. Fuel damper cap |
| 7. Clip | 8. O-ring (black) | 9. Fuel injector |
| 10. O-ring (green) | | |

A. Comply with the assembly procedure when tightening. Refer to [EM-49](#)

Refer to [GI-4, "Components"](#) for symbols in the figure.

CAUTION:

Never remove or disassemble parts unless instructed as shown in the figure.

Removal and Installation

INFOID:000000006260627

REMOVAL

WARNING:

- Put a "CAUTION: FLAMMABLE" sign in the workshop.
 - Be sure to work in a well ventilated area and furnish workshop with a CO2 fire extinguisher.
 - Never smoke while servicing fuel system. Keep open flames and sparks away from the work area.
 - To avoid the danger of being scalded, never drain engine coolant when engine is hot.
1. Remove radiator core support covers (RH and LH), air duct (inlet), air cleaner cases (upper and lower) with mass air flow sensor and air duct assembly. Refer to [EM-31, "Exploded View"](#).
 2. Remove engine cover. Refer to [EM-29, "Exploded View"](#).
 3. Release the fuel pressure. Refer to [EC-546, "Inspection"](#).

FUEL INJECTOR AND FUEL TUBE

< REMOVAL AND INSTALLATION >

4. Remove front wiper arm and extension cowl top. Refer to [WW-117. "Exploded View"](#) and [EXT-20. "Exploded View"](#).
5. Drain engine coolant, or when water hoses are disconnected, attach plug to prevent engine coolant leakage. Refer to [CO-11. "Draining"](#) or [EM-33. "Exploded View"](#).

CAUTION:

Perform this step when the engine is cold.

6. Remove intake manifold collector. Refer to [EM-33. "Exploded View"](#).
7. When separating fuel feed hose and fuel tube connection, disconnect quick connector as follows:
 - a. Remove quick connector cap from quick connector.
 - b. Disconnect quick connector from fuel tube as follows:

CAUTION:

Disconnect quick connector by using the quick connector release (commercial service tool: J-45488), not by picking out retainer tabs.

- i. With the sleeve side of quick connector release facing to quick connector, install the quick connector release onto fuel tube.
- ii. Insert the quick connector release (A) into quick connector (2) until sleeve (B) contacts and goes no further. Hold quick connector release on that position.

C : Insert and retain

CAUTION:

Inserting quick connector release hard will not disconnect quick connector. Hold quick connector release where it contacts and goes no further.

- iii. Draw and pull out quick connector straight from fuel tube (1).

CAUTION:

- Pull quick connector (E) holding position (D) as shown in the figure.
- Never pull with lateral force applied. O-ring inside quick connector may be damaged.
- Prepare container and cloth beforehand as fuel will leakage out.
- Avoid fire and sparks.
- Keep parts away from heat source. Especially, be careful when welding is performed around them.
- Never expose parts to battery electrolyte or other acids.
- Never bend or twist connection between quick connector and fuel feed hose (with damper) during installation/removal.
- To keep clean the connecting portion and to avoid damage and foreign materials, cover them completely with plastic bags, etc. (A) or something similar.

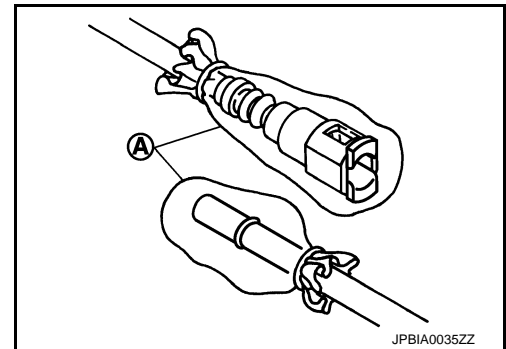
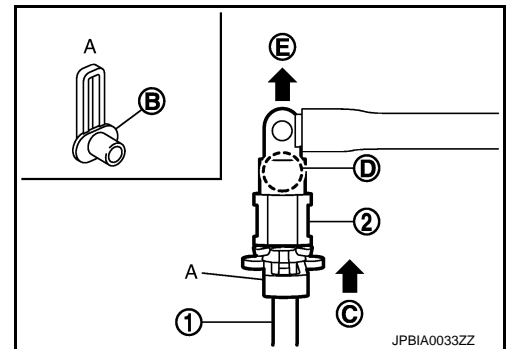

8. Disconnect harness connector from fuel injector.

FUEL INJECTOR AND FUEL TUBE

< REMOVAL AND INSTALLATION >

9. Loosen mounting bolts in the reverse order as shown in the figure, and remove fuel tube and fuel injector assembly.

← : Engine front

CAUTION:

Never tilt fuel tube, or remaining fuel in pipes may flow out from pipes.

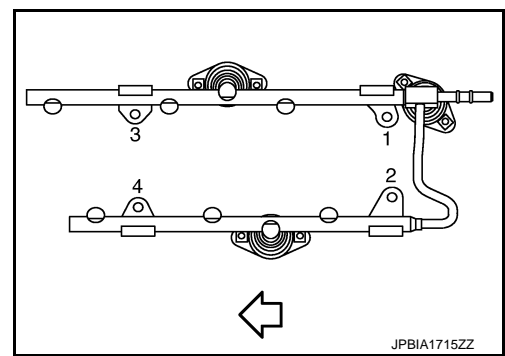

10. Remove fuel injector from fuel tube as follows:

- a. Open and remove clip (1).

3 : O-ring (green)

4 : O-ring (black)

A : Installed condition

B : Clip mounting groove

- b. Remove fuel injector (2) from fuel tube (5) by pulling straight.

CAUTION:

- Be careful with remaining fuel that may go out from fuel tube.
- Be careful not to damage injector nozzle during removal.
- Never bump or drop fuel injector.
- Never disassemble fuel injector.

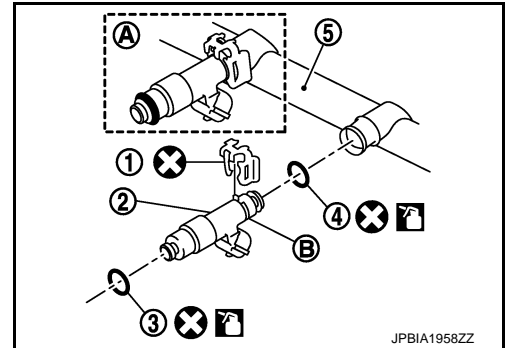

11. Remove fuel damper from fuel tube.

INSTALLATION

CAUTION:

Do not reuse O-rings.

1. Install fuel damper as follows:

- a. Install new O-ring (2) to fuel tube (1) as shown. When handling new O-ring, be careful of the following caution:

CAUTION:

- Do not reuse O-ring.
- Handle O-ring with bare hands. Never wear gloves.
- Lubricate O-ring with new engine oil.
- Never clean O-ring with solvent.
- Check that O-ring and its mating part are free of foreign material.
- When installing O-ring, be careful not to scratch it with tool or fingernails. Also be careful not to twist or stretch O-ring. If O-ring was stretched while it was being attached, never insert it quickly into fuel tube.
- Insert new O-ring straight into fuel tube. Never twist it.

- b. Install spacer (3) to fuel damper (4).

- c. Insert fuel damper straight into fuel tube.

CAUTION:

- Insert straight, checking that the axis is lined up.
- Never pressure-fit with excessive force.

Reference value : 130 N (13.3 kg, 29.2 lb)

- Insert fuel damper until (B) is touching (A) of fuel tube.

- d. Tighten bolts evenly in turn.

- After tightening bolts, check that there is no gap between fuel damper cap (5) and fuel tube.

2. Install new O-rings to fuel injector paying attention to the following.

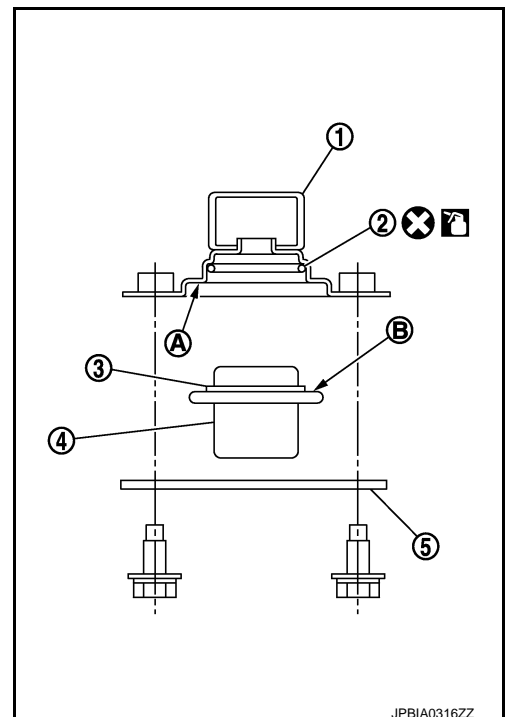

FUEL INJECTOR AND FUEL TUBE

< REMOVAL AND INSTALLATION >

CAUTION:

- Do not reuse O-rings.
- Upper and lower O-ring are different. Be careful not to confuse them.

Fuel tube side : Black

Nozzle side : Green

- Handle O-ring with bare hands. Never wear gloves.
- Lubricate O-ring with new engine oil.
- Never clean O-ring with solvent.
- Check that O-ring and its mating part are free of foreign material.
- When installing O-ring, be careful not to scratch it with tool or fingernails. Also be careful not to twist or stretch O-ring. If O-ring was stretched while it was being attached, never insert it quickly into fuel tube.
- Insert O-ring straight into fuel injector. Never decenter or twist it.

3. Install fuel injector to fuel tube as follows:

a. Insert clip (3) into clip mounting groove (F) on fuel injector (5).

2 : O-ring (black)

4 : O-ring (green)

- Insert clip so that protrusion (E) of fuel injector matches cutout (C) of clip.

CAUTION:

- Never reuse clip. Replace it with new one.
- Be careful to keep clip from interfering with O-ring. If interference occurs, replace O-ring.

b. Insert fuel injector into fuel tube (1) with clip attached.

- Insert it while matching it to the axial center.
- Insert fuel injector so that protrusion (A) of fuel tube matches cutout (B) of clip.
- Check that fuel tube flange (G) is securely fixed in flange fixing groove (D) on clip.

c. Check that installation is complete by checking that fuel injector does not rotate or come off.

- Check that protrusions of fuel injectors and fuel tubes are aligned with cutouts of clips after installation.

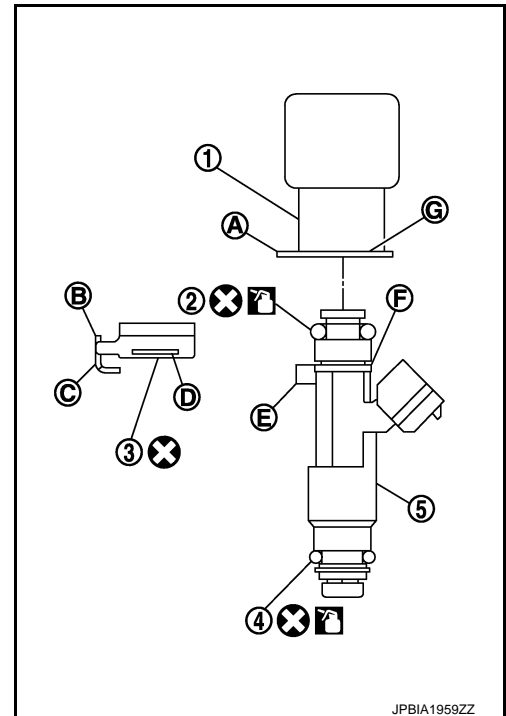

JPBIA1959ZZ

4. Install fuel tube and fuel injector assembly to intake manifold.

CAUTION:

Be careful not to let tip of injector nozzle come in contact with other parts.

- Tighten mounting bolts in two steps in numerical order as shown in the figure.

← : Engine front

 1st step : 10.1 N·m (1.0 kg·m, 7 ft·lb)

 2nd step : 22.0 N·m (2.2 kg·m, 16 ft·lb)

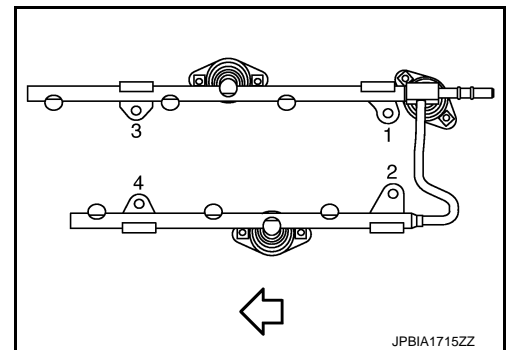

JPBIA1715ZZ

5. Connect fuel injector harness.

6. Install intake manifold collector. Refer to [EM-33, "Exploded View"](#).

7. Connect quick connector between fuel feed hose and fuel tube connection with the following procedure:

FUEL INJECTOR AND FUEL TUBE

< REMOVAL AND INSTALLATION >

- a. Check no foreign substances are deposited in and around fuel tube and quick connector, and no damage on them.
- b. Thinly apply new engine oil around fuel tube from tip end to spool end.
- c. Align center to insert quick connector straightly into fuel tube.
 - Insert quick connector (1) to fuel tube until top spool (2) is completely inside quick connector, and 2nd level spool (3) exposes right below quick connector.

B : Fitted condition

⇐ : Upright insertion

CAUTION:

- Hold (A) position as shown in the figure when inserting fuel tube into quick connector.
- Carefully align center to avoid inclined insertion to prevent damage to O-ring inside quick connector.
- Insert until you hear a “click” sound and actually feel the engagement.
- To avoid misidentification of engagement with a similar sound, be sure to perform the next step.

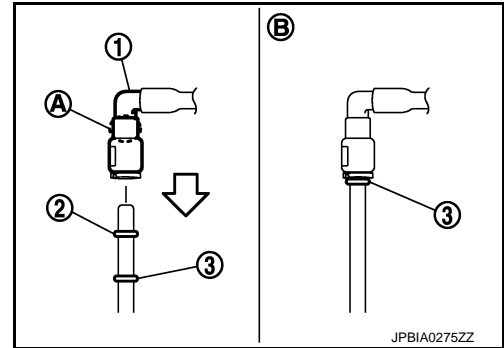

- d. Pull quick connector by hand holding position. Check it is completely engaged (connected) so that it does not come out from fuel tube.
- e. Install quick connector cap (3) to quick connector.

1 : Fuel feed hose

2 : Fuel tube

B : Upper view

- Install quick connector cap with arrow (A) on surface facing in direction of quick connector (fuel feed hose side).

CAUTION:

If quick connector cap cannot be installed smoothly, quick connector may have not been installed correctly. Check connection again.

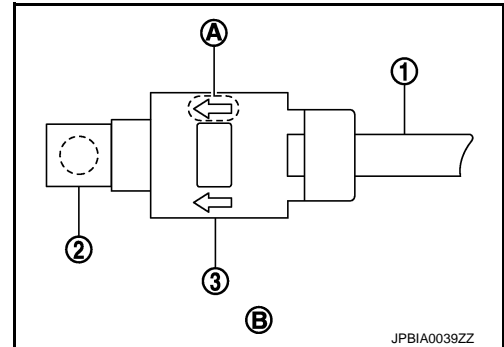

- f. Secure fuel feed hose to clamp of quick connector cap.
8. Install in the reverse order of removal after this step.

Inspection

INFOID:000000006260628

INSPECTION AFTER INSTALLATION

Check on Fuel Leakage

1. Turn ignition switch “ON” (with the engine stopped). With fuel pressure applied to fuel piping, check there are no fuel leakage at connection points.

NOTE:

Use mirrors for checking at points out of clear sight.

2. Start the engine. With engine speed increased, check again that there are no fuel leakage at connection points.

CAUTION:

Never touch the engine immediately after stopped, as the engine becomes extremely hot.

IGNITION COIL, SPARK PLUG AND ROCKER COVER

< REMOVAL AND INSTALLATION >

IGNITION COIL, SPARK PLUG AND ROCKER COVER

Exploded View

INFOID:000000006260629

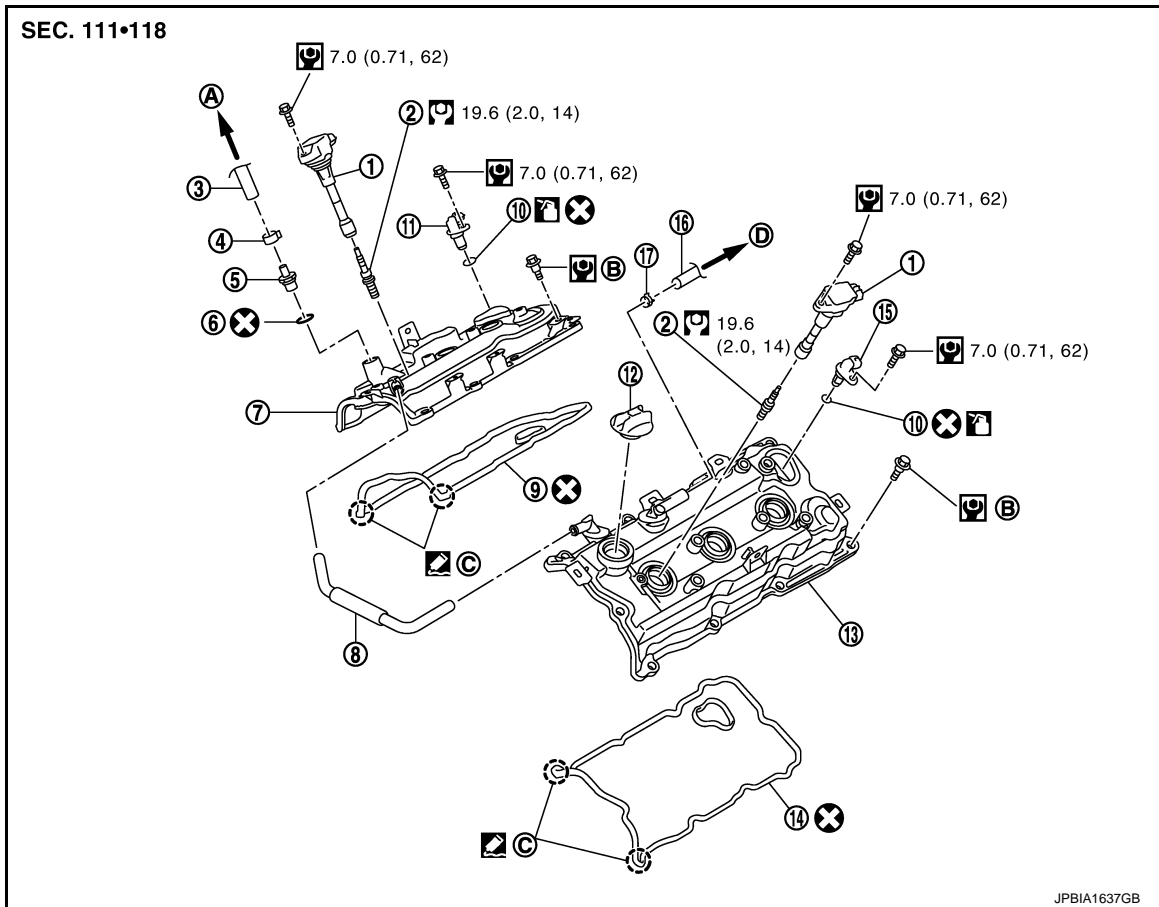

- | | | |
|---------------------------------|---|---|
| 1. Ignition coil | 2. Spark plug | 3. PCV hose |
| 4. Clamp | 5. PCV valve | 6. O-ring |
| 7. Rocker cover (bank 1) | 8. PCV hose | 9. Rocker cover gasket (bank 1) |
| 10. O-ring | 11. Camshaft position sensor (PHASE) (bank 1) | 12. Oil filler cap |
| 13. Rocker cover (bank 2) | 14. Rocker cover gasket (bank 2) | 15. Camshaft position sensor (PHASE) (bank 2) |
| 16. PCV hose | 17. Clamp | |
| A. To intake manifold collector | B. Comply with the assembly procedure when tightening. Refer to EM-54 | C. Camshaft bracket side |
| D. To air duct assembly | | |

Refer to [GI-4, "Components"](#) for symbols in the figure.

Removal and Installation

INFOID:000000006260630

REMOVAL

- Remove the following parts:
 - Engine cover: Refer to [EM-29, "Exploded View"](#).
 - Air cleaner cases (upper and lower) and air duct assembly: Refer to [EM-31, "Exploded View"](#).
 - Intake manifold collector: Refer to [EM-33, "Exploded View"](#).
- Disconnect PCV hose from rocker cover.

IGNITION COIL, SPARK PLUG AND ROCKER COVER

< REMOVAL AND INSTALLATION >

3. Remove camshaft position sensor (PHASE) (bank 1 and bank 2).

A : Keep off any magnetic materials

CAUTION:

- Handle carefully to avoid dropping and shocks.
- Never disassemble
- Never allow metal powder to adhere to magnetic part at sensor tip.
- Never place sensors in a location where they are exposed to magnetism.

4. Remove PCV valve and O-ring from rocker cover, if necessary.
5. Remove oil filler cap from rocker cover, if necessary.
6. Remove ignition coil.

CAUTION:

Never shock ignition coil.

7. Remove harness clips on the rocker cover.
8. Loosen bolts in the reverse order shown in the figure.

⇐ : Engine front

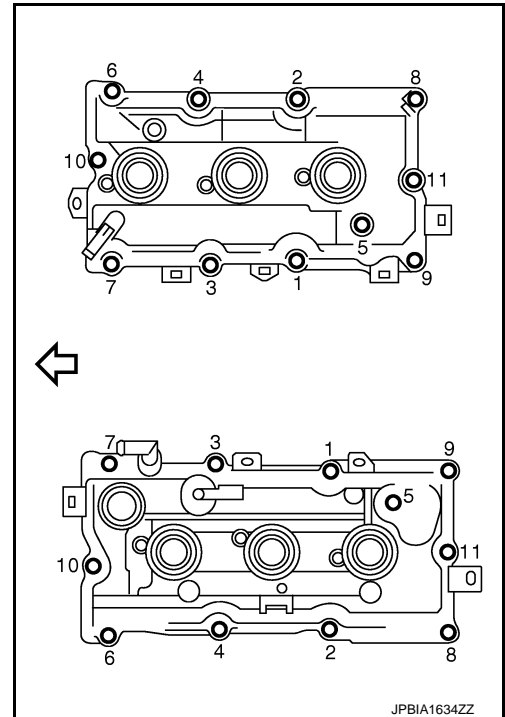
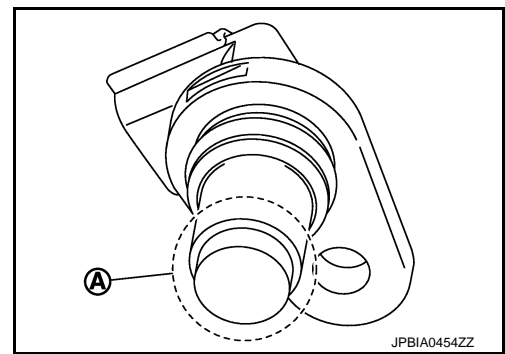

9. Remove rocker cover gasket from rocker cover.
10. Use scraper to remove all traces of liquid gasket from cylinder head and camshaft bracket (No. 1).

CAUTION:

Never scratch or damage the mating surface when cleaning off old liquid gasket.

INSTALLATION

CAUTION:

Do not reuse O-rings.

IGNITION COIL, SPARK PLUG AND ROCKER COVER

< REMOVAL AND INSTALLATION >

1. Apply liquid gasket to the position shown in the figure with the following procedure:

- A : Liquid gasket application point
- F : View F
- l : End surface of camshaft bracket (No. 1)
- b : 4 mm (0.16 in)
- c : $\phi 2.5 - 3.5$ mm (0.098 - 0.138 in)
- d : 5 mm (0.20 in)
- g : 10 mm (0.39 in)
- ↔ : Engine front

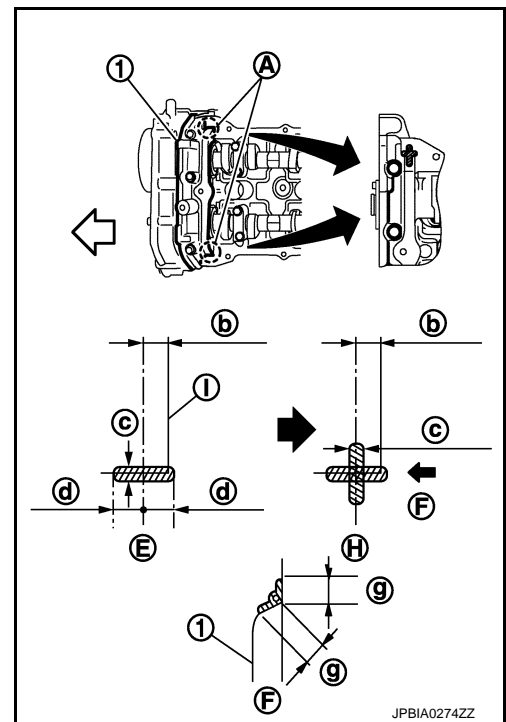

Use Genuine RTV silicone sealant or equivalent. Refer to [GI-22, "Recommended Chemical Products and Sealants"](#).

- a. Refer to figure (E) to apply liquid gasket to joint part of camshaft bracket (No. 1) (1) and cylinder head.
- b. Refer to figure (H) to apply liquid gasket in 90 degrees to figure.



2. Install rocker cover gasket to rocker cover.
3. Install rocker cover.
 - Check if rocker cover gasket is not dropped from the installation groove of rocker cover.
4. Tighten bolts in two steps separately in numerical order as shown in the figure.

↔ : Engine front

-  **1st step : 1.96 N-m (0.20 kg-m, 17 in-lb)**
-  **2nd step : 8.33 N-m (0.85 kg-m, 74 in-lb)**

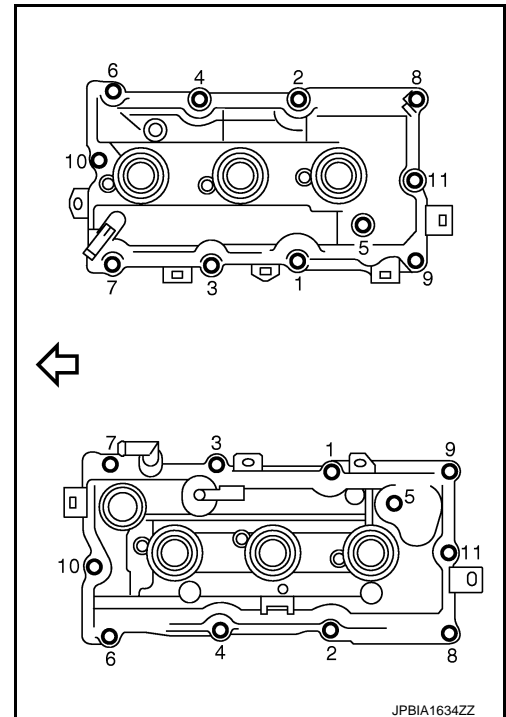

5. Install in the reverse order of removal after this step.

TIMING CHAIN

< REMOVAL AND INSTALLATION >

TIMING CHAIN

Exploded View

INFOID:000000006260631

A

EM

C

D

E

F

G

H

I

J

K

L

M

N

O

P

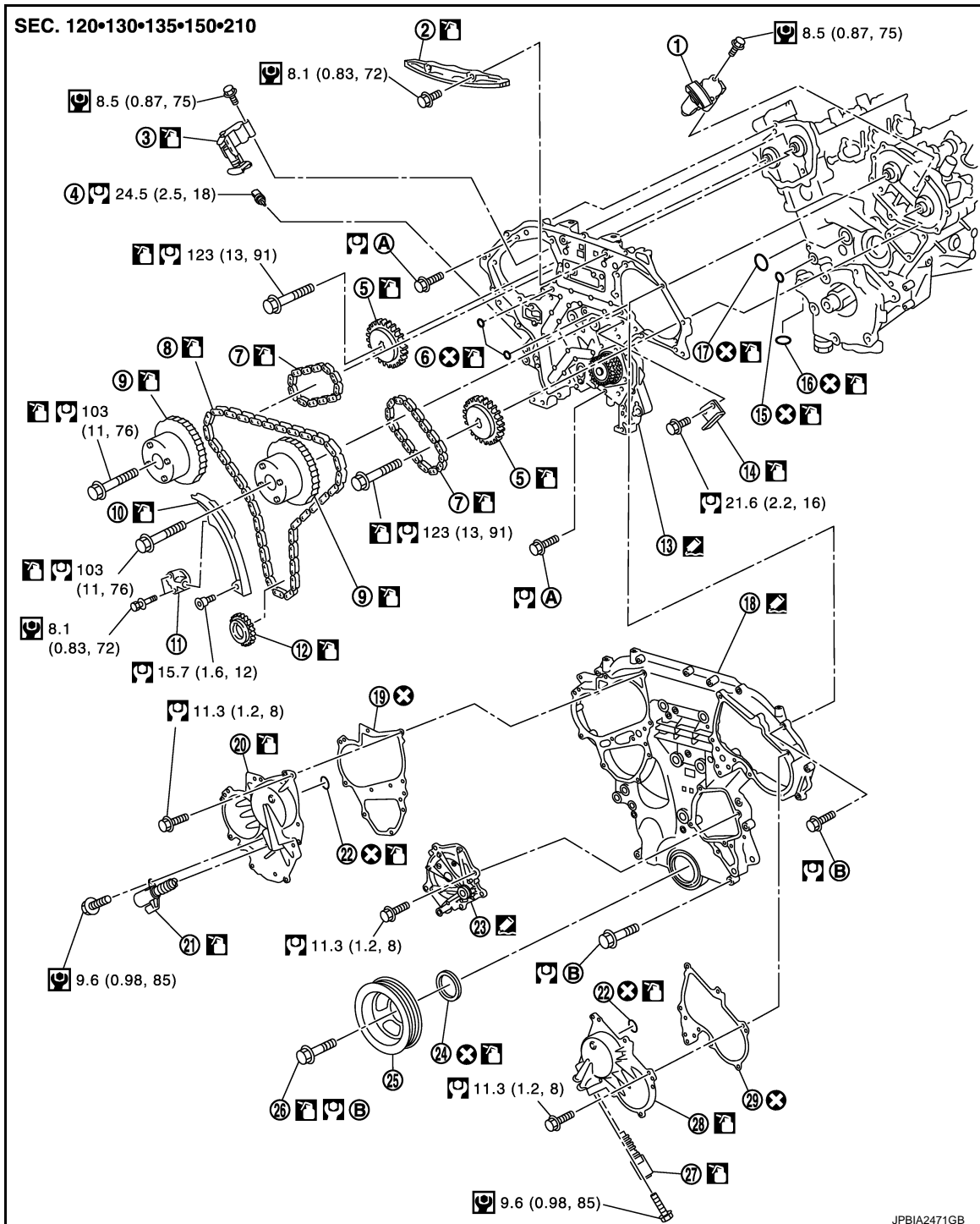

JPBIA2471GB

- | | | |
|--|--------------------------------------|--|
| 1. Timing chain tensioner (secondary) (bank 2) | 2. Internal chain guide | 3. Timing chain tensioner (secondary) (bank 1) |
| 4. Oil temperature sensor | 5. Camshaft sprocket (EXH) | 6. O-ring |
| 7. Timing chain (secondary) | 8. Timing chain (primary) | 9. Camshaft sprocket (INT) |
| 10. Slack guide | 11. Timing chain tensioner (primary) | 12. Crankshaft sprocket |
| 13. Rear timing chain case | 14. Tension guide | 15. O-ring |
| 16. O-ring | 17. O-ring | 18. Front timing chain case |

TIMING CHAIN

< REMOVAL AND INSTALLATION >

- | | | |
|--|--|---|
| 19. Valve timing control cover gasket (bank 1) | 20. Valve timing control cover (bank 1) | 21. Intake valve timing control solenoid valve (bank 1) |
| 22. Seal ring | 23. Water pump cover | 24. Front oil seal |
| 25. Crankshaft pulley | 26. Crankshaft pulley bolt | 27. Intake valve timing control solenoid valve (bank 2) |
| 28. Valve timing control cover (bank 2) | 29. Valve timing control cover gasket (bank 2) | |
- A. Comply with the assembly procedure when tightening. Refer to [EM-94](#)
- B. Comply with the assembly procedure when tightening. Refer to [EM-58](#)

Refer to [GI-4, "Components"](#) for symbols in the figure.

Removal and Installation

INFOID:000000006260632

REMOVAL

1. Drain engine oil. Refer to [LU-8, "Draining"](#).
2. Drain engine coolant from inside engine. Refer to [EM-90, "Setting"](#).
3. Remove intake manifold collector. Refer to [EM-33, "Exploded View"](#).
4. Remove rocker covers (bank 1 and bank 2). Refer to [EM-54, "Exploded View"](#).
5. Remove oil pans (lower and upper) and oil strainer. Refer to [EM-43, "Exploded View"](#).
6. Remove drive belt, idler pulleys and bracket. Refer to [EM-17, "Removal and Installation"](#) and [EM-30, "Exploded View"](#).
7. Remove power steering oil pump with piping connected, and temporarily secure it to aside. Refer to [ST-56, "Exploded View"](#).
8. Separate engine harness removing their brackets from front timing chain case.
9. Remove valve timing control covers.
 - Loosen mounting bolts in the reverse order as shown in the figure.

- A : Bank 1
 B : Bank 2
 C : Dowel pin hole

CAUTION:

Shaft is internally jointed with camshaft sprocket (INT) center hole. When removing, keep it horizontal until it is completely disconnected.

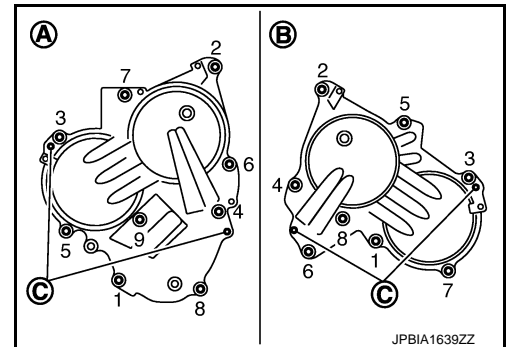

10. Obtain No. 1 cylinder at TDC of its compression stroke as follows:
 - a. Rotate crankshaft pulley clockwise to align timing mark (grooved line without color) (←) with timing indicator.

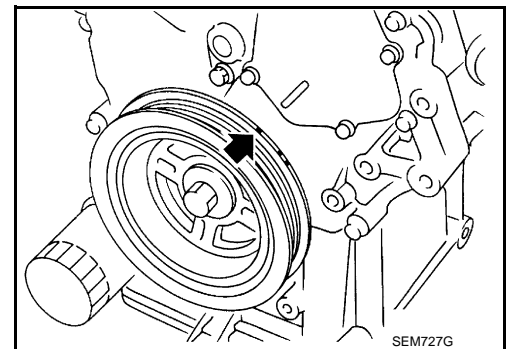

TIMING CHAIN

< REMOVAL AND INSTALLATION >

- b. Check that intake and exhaust cam noses on No. 1 cylinder (engine front side of bank 1) are located as shown in the figure.

↔ : Engine front

- If not, turn crankshaft one revolution (360 degrees) and align as shown in the figure.

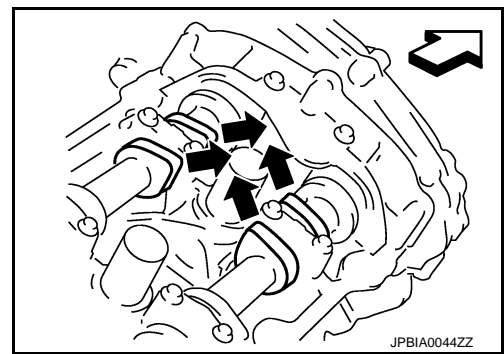

11. Remove crankshaft pulley as follows:

- a. Fix crankshaft with the pulley holder (commercial service tool) (A).

1 : Crankshaft pulley

- b. Loosen crankshaft pulley bolt and locate bolt seating surface at 10 mm (0.39 in) from its original position.

CAUTION:

Never remove crankshaft pulley bolt as it will be used as a supporting point for suitable puller.

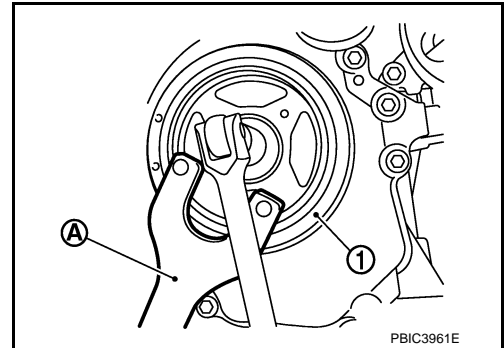

- c. Place suitable puller tab on holes of crankshaft pulley, and pull crankshaft pulley through.

CAUTION:

Never put suitable puller tab on crankshaft pulley periphery, as this will damage internal damper.

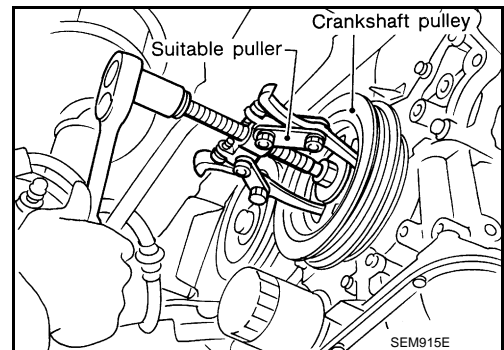

12. Remove front timing chain case as follows:

- a. Loosen mounting bolts in the reverse order as shown in the figure.

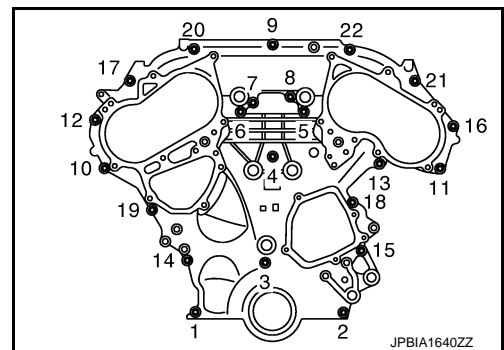

A
EM
C
D
E
F
G
H
I
J
K
L
M
N
O
P

TIMING CHAIN

< REMOVAL AND INSTALLATION >

- b. Insert a suitable tool (A) into the notch at the top of front timing chain case as shown in the figure.
- c. Pry off case by moving the tool as shown.
 - Use the seal cutter [SST: KV10111100 (J-37228)] to cut liquid gasket for removal.

CAUTION:

- Never use screwdrivers or something similar.
- After removal, handle front timing chain case carefully so it does not tilt, cant, or warp under a load.

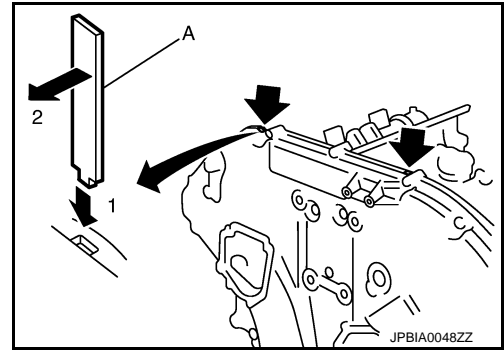

13. Remove water pump cover from front timing chain case.
 - Use the seal cutter [SST: KV10111100 (J-37228)] to cut liquid gasket for removal.

14. Remove front oil seal from front timing chain case using a suitable tool.
 - Use a screwdriver for removal.

CAUTION:

Be careful not to damage front timing chain case.

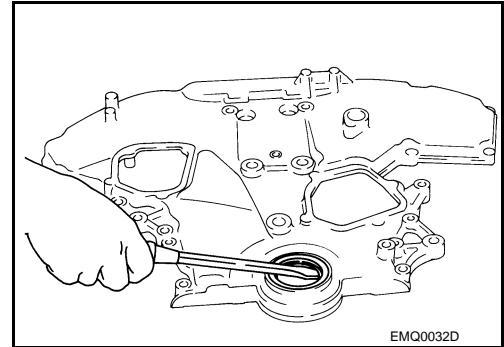

15. Remove O-ring (1) from rear timing chain case.

- A : Bank 1
- B : Bank 2

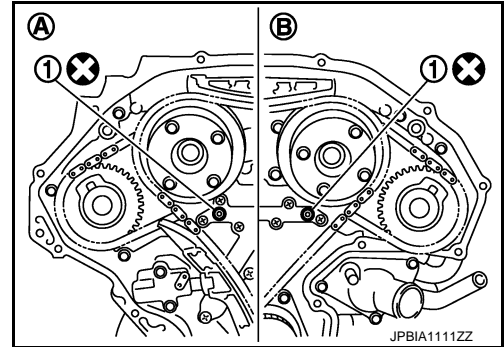

16. Remove timing chain tensioner (primary) as follows:

- a. Remove lower mounting bolt (1).
- b. Loosen upper mounting bolt (2) slowly, and then turn timing chain tensioner (primary) (3) on the mounting bolt so that plunger (4) is fully expanded.

NOTE:

Even if plunger is fully expanded, it is not dropped from the body of timing chain tensioner (primary).

- c. Remove upper mounting bolt, and then remove timing chain tensioner (primary).

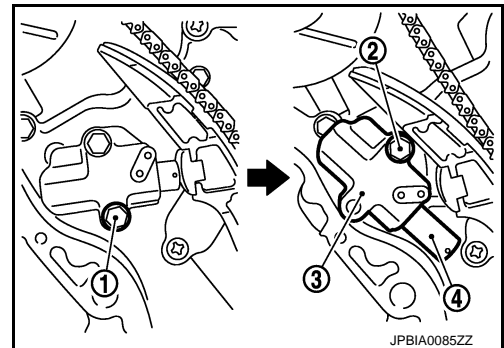

TIMING CHAIN

< REMOVAL AND INSTALLATION >

17. Remove internal chain guide, tension guide and slack guide.

NOTE:

Tension guide can be removed after removing timing chain (primary).

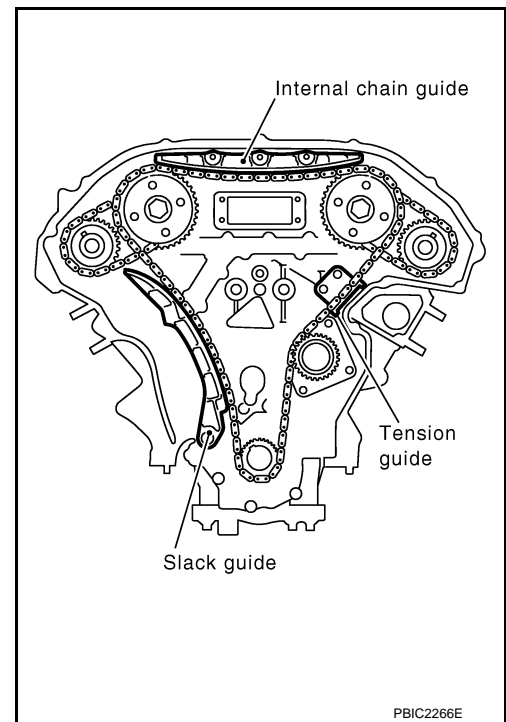

18. Remove timing chain (primary) and crankshaft sprocket.

CAUTION:

After removing timing chain (primary), never turn crankshaft and camshaft separately, or valves will strike the piston heads.

19. Remove timing chain (secondary) and camshaft sprockets as follows:

- a. Attach a suitable stopper pin (B) to the bank 1 (A) and bank 2 (C) timing chain tensioners (secondary) (1).

NOTE:

- Use approximately 0.5 mm (0.02 in) dia. hard metal pin as a stopper pin.
- For removal of timing chain tensioner (secondary), refer to [EM-98, "Exploded View"](#). [Removing camshaft bracket (No. 1) is required.]

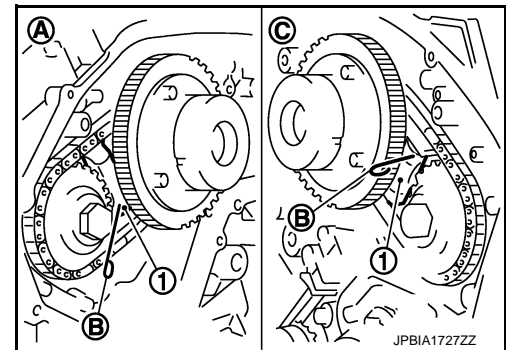

- b. Remove camshaft sprockets (INT and EXH) mounting bolts.

- Secure the hexagonal portion of camshaft using a wrench to loosen mounting bolts.

CAUTION:

Never loosen mounting bolts with securing anything other than the camshaft hexagonal portion or with tensioning the timing chain.

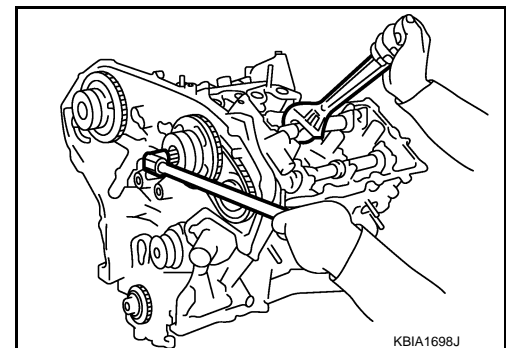

- c. Remove timing chain (secondary) together with camshaft sprockets.

- Turn camshaft slightly to secure slackness of timing chain on timing chain tensioner (secondary) side.

TIMING CHAIN

< REMOVAL AND INSTALLATION >

- Insert 0.5 mm (0.020 in) thick metal or resin plate between timing chain and timing chain tensioner plunger (guide) (E). Remove timing chain (secondary) (2) together with camshaft sprockets with timing chain loose from guide groove.

- 1 : Timing chain tensioner (secondary)
- A : Bank 1
- B : View B
- C : Stopper pin
- D : Plate
- F : Timing chain tensioner (body)

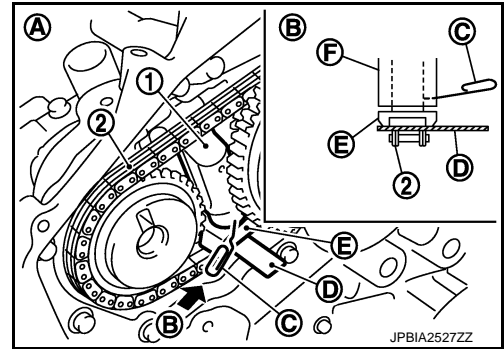

CAUTION:

Be careful of plunger coming-off when removing timing chain (secondary). This is because plunger of timing chain tensioner (secondary) moves during operation, leading to coming-off of fixed stopper pin.

NOTE:

- Camshaft sprocket (INT) is two-for-one structure of sprockets for timing chain (primary) and for timing chain (secondary).
- Figure is shown as an example of bank 1.
- When handling camshaft sprocket (INT), be careful of the following caution:

CAUTION:

- Handle carefully to avoid any shock to camshaft sprocket.
- Never disassemble. [Never loosen bolts (A) as shown in the figure].

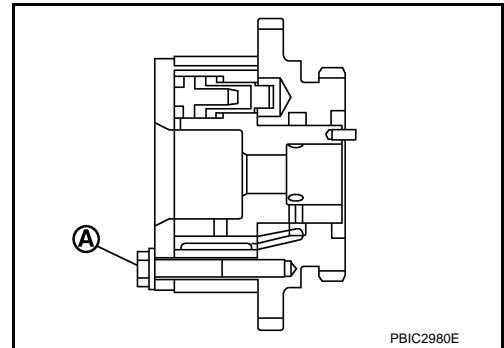

20. Remove timing chain tensioners (secondary) from cylinder head as follows, if necessary.

- Remove timing chain tensioners (secondary) with a stopper pin attached.

21. Use a scraper to remove all traces of old liquid gasket from front timing chain case, and opposite mating surfaces.

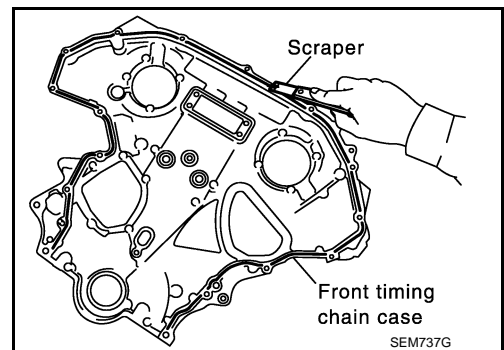

- Remove old liquid gasket from bolt hole (B) and thread.

- A : Remove sticking old liquid gasket

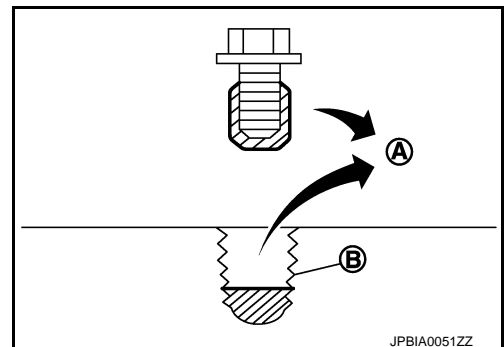

TIMING CHAIN

< REMOVAL AND INSTALLATION >

- Use a scraper to remove all traces of old liquid gasket from water pump cover.

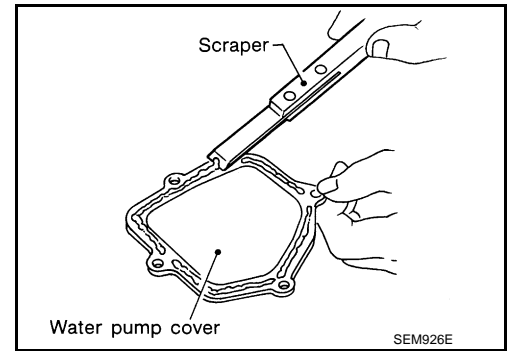

INSTALLATION

CAUTION:

Do not reuse O-rings.

NOTE:

The below figure shows the relationship between the mating mark on each timing chain and that on the corresponding sprocket, with the components installed.

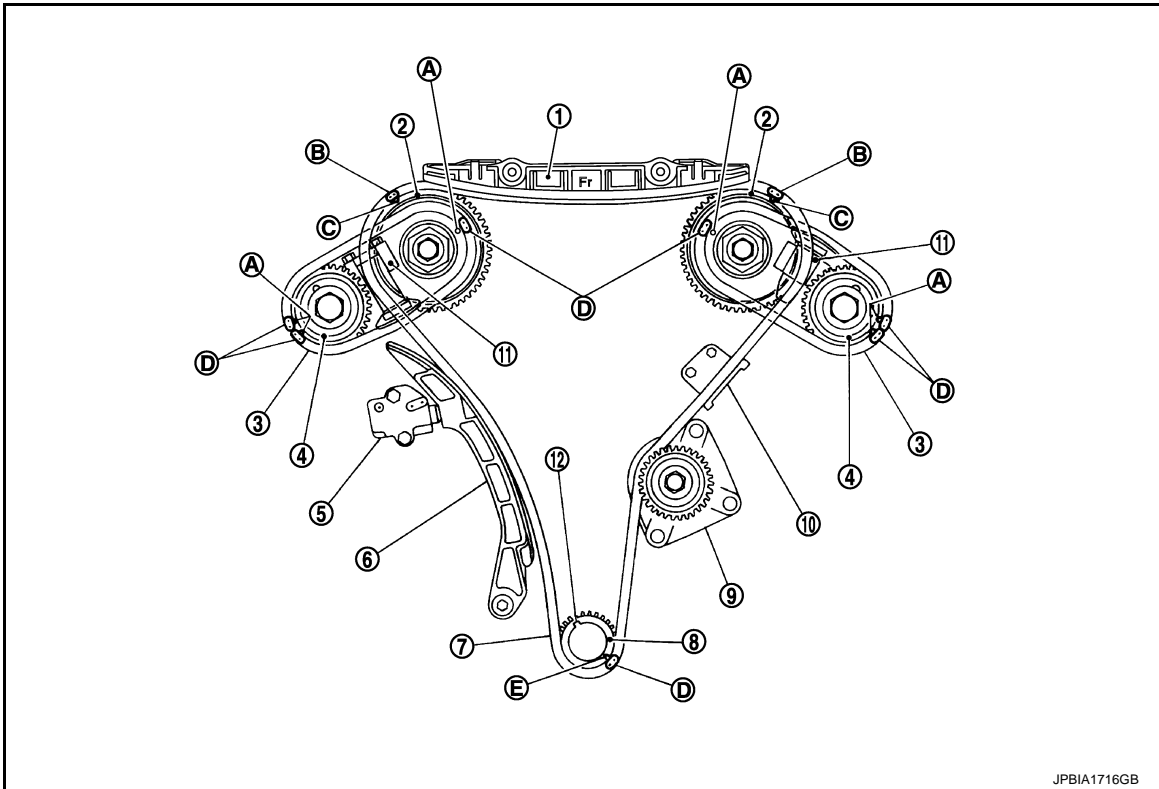

- | | | |
|----------------------------|--|-----------------------------|
| 1. Internal chain guide | 2. Camshaft sprocket (INT) | 3. Timing chain (secondary) |
| 4. Camshaft sprocket (EXH) | 5. Timing chain tensioner (primary) | 6. Slack guide |
| 7. Timing chain (primary) | 8. Crankshaft sprocket | 9. Water pump |
| 10. Tension guide | 11. Timing chain tensioner (secondary) | 12. Crankshaft key |
| A. Mating mark | B. Mating mark (pink link) | C. Mating mark (punched) |
| D. Mating mark (orange) | E. Mating mark (notched) | |

- Install timing chain tensioners (secondary) to cylinder head as follows if removed. Refer to [EM-98, "Exploded View"](#).
 - Install timing chain tensioners (secondary) with a stopper pin attached and new O-ring.

TIMING CHAIN

< REMOVAL AND INSTALLATION >

2. Check that dowel pin (A) and crankshaft key (1) are located as shown in the figure. (No. 1 cylinder at compression TDC)

NOTE:

Though camshaft does not stop at the position as shown in the figure, for the placement of cam nose, it is generally accepted camshaft is placed for the same direction of the figure.

Camshaft dowel pin

: At cylinder head upper face side in each bank

Crankshaft key

: At cylinder head side of bank 1

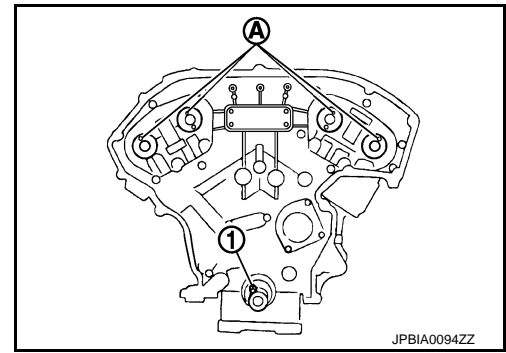

CAUTION:

Hole on small dia. side must be used for intake side dowel pin hole. Never misidentify (ignore big dia. side).

3. Install timing chain (secondary) and camshaft sprockets (INT and EXH) as follows:

CAUTION:

Mating marks between timing chain and sprockets slip easily. Confirm all mating mark positions repeatedly during the installation process.

- a. Push plunger of timing chain tensioner (secondary) and keep it pressed in with stopper pin (A).

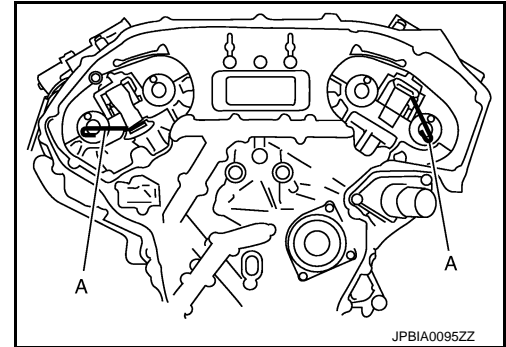

- b. Install timing chain (secondary) (1) and camshaft sprockets (INT and EXH).

- A : Camshaft sprocket (INT) back face
- B : Orange link
- C : Mating mark (Circle)
- D : Camshaft sprocket (EXH) back face
- E : Mating mark (2 circle on front face)
- F : Dowel pin groove
- G : Mating mark (2 ovals on front face)
- H : Mating mark (Oval)
- I : Dowel pin hole

NOTE:

Figure shows bank 1 (rear view).

- Align the mating marks on timing chain (secondary) (orange link) with the ones on camshaft sprockets (INT and EXH) (punched), and install them.

NOTE:

- Mating marks for camshaft sprocket (INT) are on the back side of camshaft sprocket (secondary).
- There are two types of mating mark, circle and oval types. They should be used for the bank 1 and bank 2, respectively.

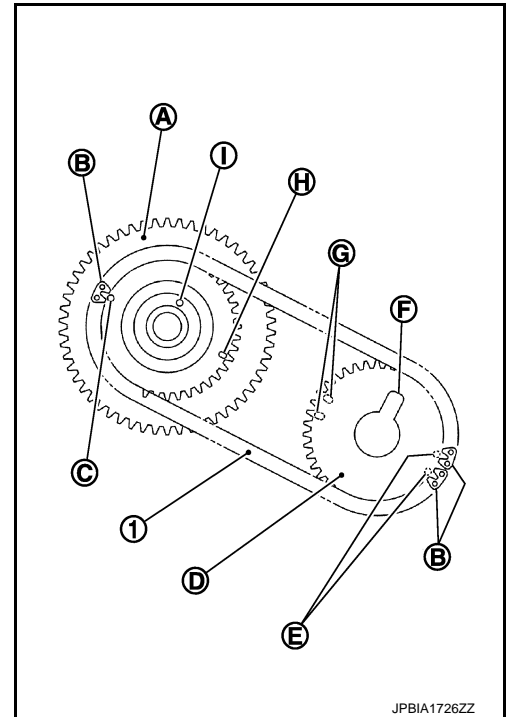

Bank 1 : Use circle type.

Bank 2 : Use oval type.

- Align dowel pin on camshafts with the groove or hole on sprockets, and install them.

TIMING CHAIN

< REMOVAL AND INSTALLATION >

- On the intake side, align dowel pin on the camshaft front end with dowel pin hole on the back side of camshaft sprocket, and install them.
- On the exhaust side, align dowel pin on camshaft front end with dowel pin groove on camshaft sprocket, and install them.
- In case that positions of each mating mark and each dowel pin are not fit on mating parts, make fine adjustment to the position holding the hexagonal portion on camshaft with wrench or equivalent.
- Mounting bolts for camshaft sprockets must be tightened in the next step. Tightening them by hand is enough to prevent the dislocation of dowel pins.
- It may be difficult to visually check the dislocation of mating marks during and after installation. To make the matching easier, make a mating mark (A) on the top of sprocket teeth and its extended line in advance with paint.

B : Mating mark (orange link)

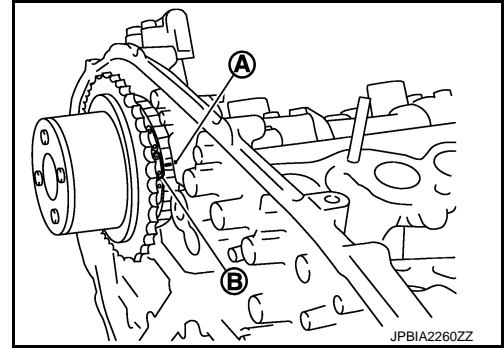

- c. After confirming the mating marks are aligned, tighten camshaft sprocket mounting bolts.
- Secure camshaft using wrench at the hexagonal portion to tighten mounting bolts.

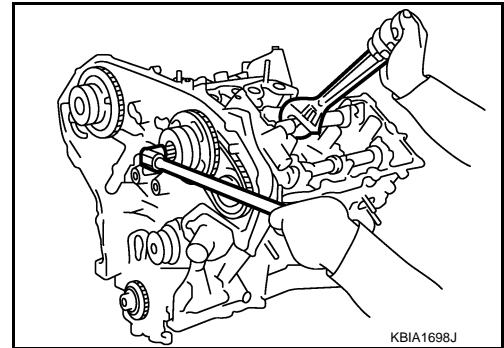

- d. Pull stopper pins (B) out from timing chain tensioners (secondary) (1).

A : Bank 1

C : Bank 2

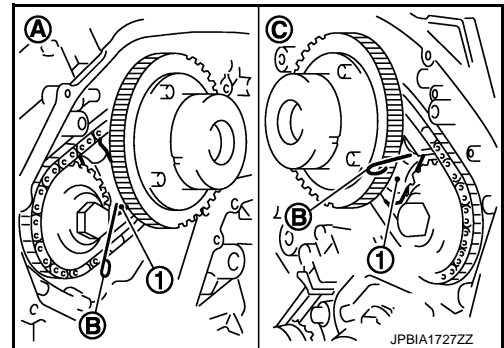

4. Install tension guide.
5. Install timing chain (primary) as follows:
- a. Install crankshaft sprocket (1).

A : Crankshaft side

B : Engine front

C : Mating mark (front side)

- Check the mating marks on crankshaft sprocket face the front of the engine.

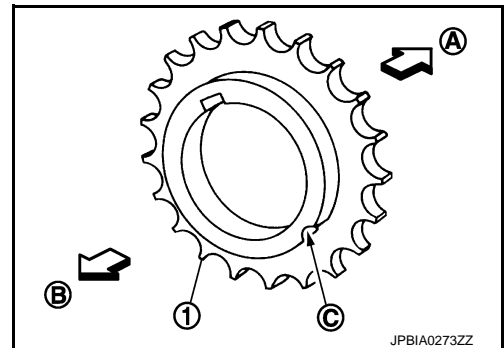

- b. Install timing chain (primary).

TIMING CHAIN

< REMOVAL AND INSTALLATION >

- Install timing chain (primary) so the mating mark (punched) (B) on camshaft sprocket (INT) (1) is aligned with the pink link (A) on timing chain, while the mating mark (notched) (C) on crankshaft sprocket (2) is aligned with the orange link (D) on timing chain, as shown in the figure.

3 : Water pump

- When it is difficult to align mating marks of timing chain (primary) with each sprocket, gradually turn camshaft using wrench on the hexagonal portion to align it with the mating marks.
- During alignment, be careful to prevent dislocation of mating mark alignments of timing chains (secondary).

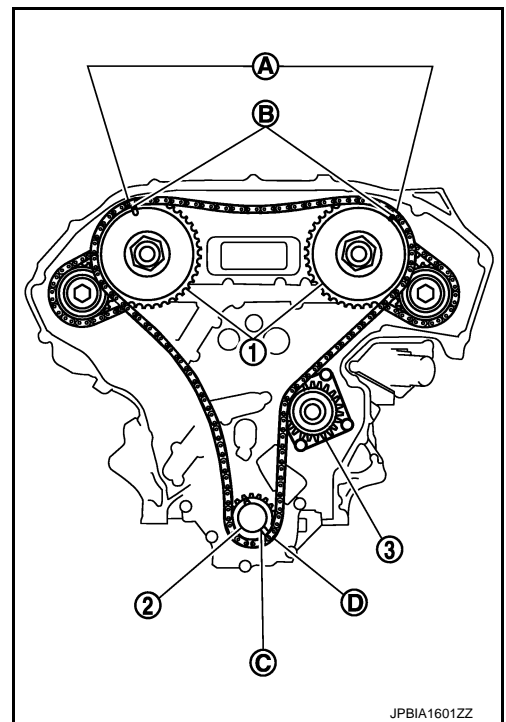

6. Install internal chain guide (1) and slack guide (2).

3 : Tension guide

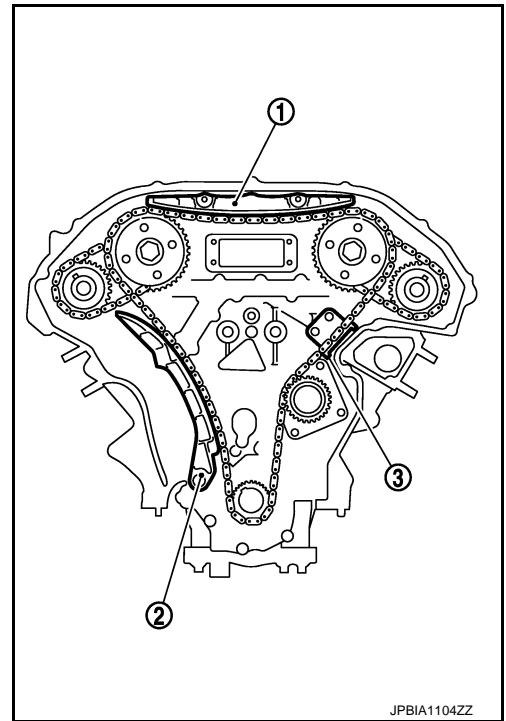

CAUTION:

Never over tighten slack guide mounting bolt (2). It is normal for a gap (A) to exist under the bolt seat when mounting bolt is tightened to specification.

1 : Slack guide

3 : Cylinder block

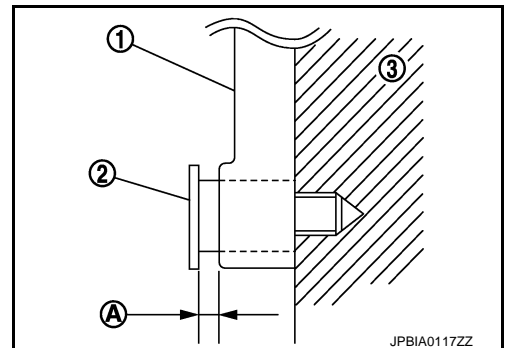

TIMING CHAIN

< REMOVAL AND INSTALLATION >

7. Install the timing chain tensioner (primary) with the following procedure:

- a. Pull plunger stopper tab (A) up (or turn lever downward) so as to remove plunger stopper tab from the ratchet of plunger (D).

NOTE:

Plunger stopper tab and lever (C) are synchronized.

- b. Push plunger into the inside of tensioner body.
- c. Hold plunger in the fully compressed position by engaging plunger stopper tab with the tip of ratchet.
- d. To secure lever, insert stopper pin (E) through hole of lever into tensioner body hole (B).
 - The lever parts and the tab are synchronized. Therefore, the plunger will be secured under this condition.

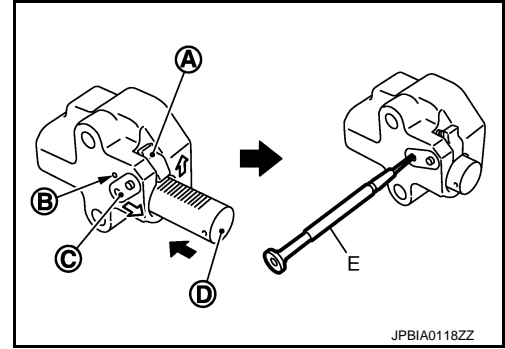

JPBIA0118ZZ

NOTE:

Figure shows the example of 1.2 mm (0.047 in) diameter thin screwdriver being used as the stopper pin.

- e. Install timing chain tensioner (primary) (1).
 - Remove any dirt and foreign materials completely from the back and the mounting surfaces of timing chain tensioner (primary).
- f. Pull out stopper pin (A) after installing, and then release plunger.

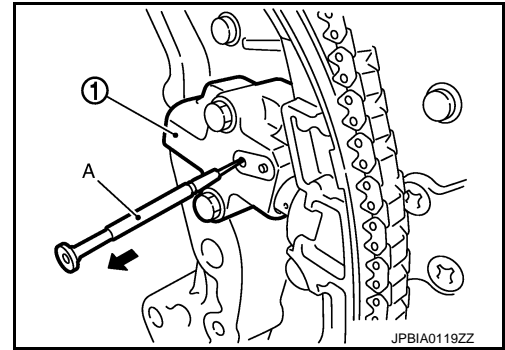

JPBIA0119ZZ

8. Check again that the mating marks on each sprocket and each timing chain have not slipped out of alignment.
9. Install new O-rings (1) on rear timing chain case.

- A : Bank 1
- B : Bank 2

CAUTION:

Do not reuse O-rings.

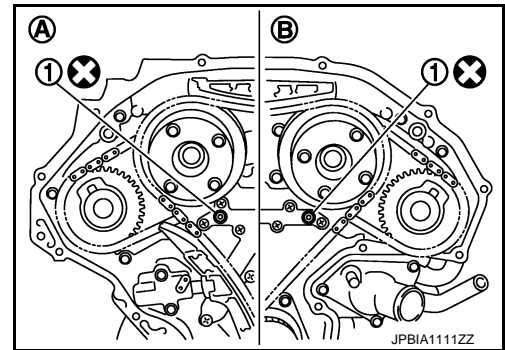

JPBIA1111ZZ

10. Install new front oil seal on front timing chain case.
 - Apply new engine oil to both oil seal lip and dust seal lip.
 - Install it so that each seal lip is oriented as shown in the figure.

- A : Oil seal lip
- B : Dust seal lip
- ← : Engine inside
- : Engine outside

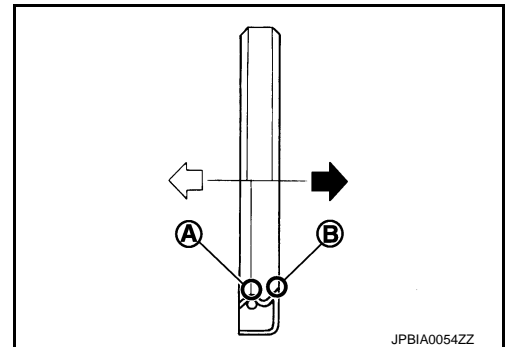

JPBIA0054ZZ

A
EM
C
D
E
F
G
H
I
J
K
L
M
N
O
P

TIMING CHAIN

< REMOVAL AND INSTALLATION >

- Using a suitable drift [outer diameter: 60 mm (2.36 in)], press-fit oil seal until it becomes flush with front timing chain case end face.
- Check the garter spring is in position and seal lip is not inverted.

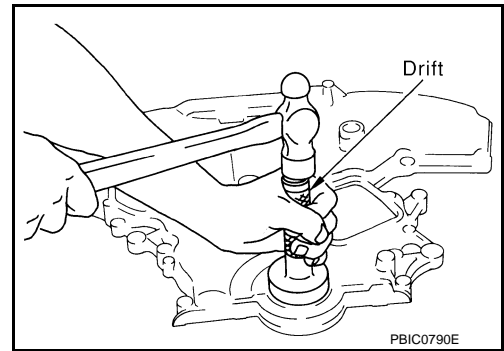

11. Install water pump cover to front timing chain case.
- Apply a continuous bead of liquid gasket with the tube presser (commercial service tool) to water pump cover (1) as shown in the figure.

a : ϕ 2.3 - 3.3 mm (0.091 - 0.130 in)

Use Genuine RTV Silicone Sealant or equivalent. Refer to [GI-22, "Recommended Chemical Products and Sealants"](#).

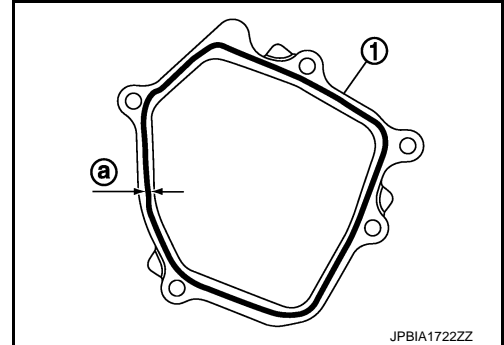

12. Install front timing chain case as follows:
- a. Apply a continuous bead of liquid gasket with the tube presser (commercial service tool) to front timing chain case back side as shown in the figure.

D : Bolt hole

E : Protrusion

f : ϕ 2.6 - 3.6 mm (0.102 - 0.142 in)

Use Genuine RTV Silicone Sealant or equivalent. Refer to [GI-22, "Recommended Chemical Products and Sealants"](#).

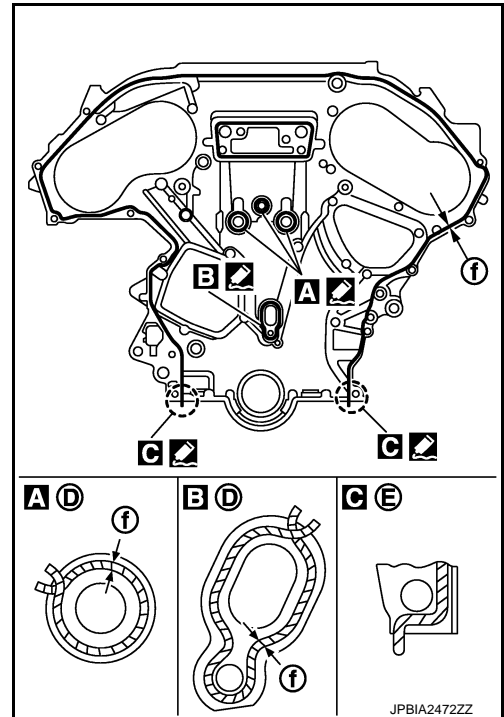

- b. Install front timing chain case as to fit its dowel pin hole together dowel pin on rear timing chain case.

TIMING CHAIN

< REMOVAL AND INSTALLATION >

- c. Tighten mounting bolts to the specified torque in numerical order as shown in the figure.
- There are two types of mounting bolt. Refer to the following for locating bolts.

M8 bolts : 1, 2

: 28.4 N·m (2.9 kg-m, 21 ft-lb)

M6 bolts : Except the above

: 12.7 N·m (1.3 kg-m, 9 ft-lb)

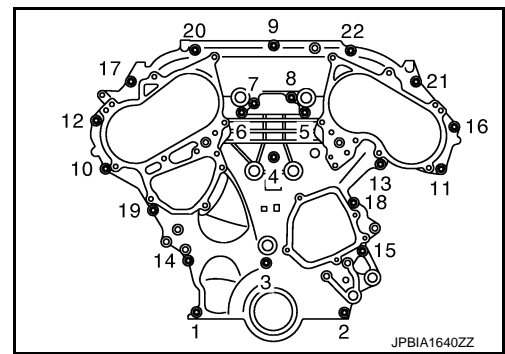

- d. After all bolts tightening, retighten them to the specified torque in numerical order as shown in the figure.

CAUTION:

Be sure to wipe off any excessive liquid gasket leaking on surface mating with oil pan (upper).

- e. After installing front timing chain case, check the surface height difference between the following parts on the oil pan (upper) mounting surface.

Standard

Front timing chain case to rear timing chain case:
-0.14 to 0.14 mm (-0.006 to 0.006 in)

- If not within the standard, repeat the installation procedure.

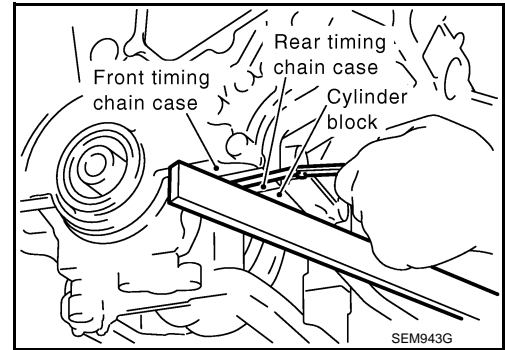

13. Install intake valve timing control covers as follows:

- Install new seal rings in shaft grooves.
- Being careful not to move seal rings from the installation grooves, align dowel pins on front timing chain case with the holes to install valve timing control covers.
- Tighten mounting bolts in numerical order as shown in the figure.

- A : Bank 1
- B : Bank 2
- C : Dowel pin hole

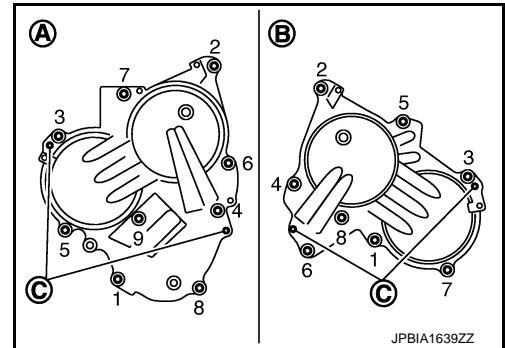

14. Install crankshaft pulley as follows:

- Install crankshaft pulley, taking care not to damage front oil seal.
 - When press-fitting crankshaft pulley with a plastic hammer, tap on its center portion (not circumference).
- Fix crankshaft with the pulley holder (commercial service tool).
- Tighten crankshaft pulley bolt.

: 44.1 N·m (4.5 kg-m, 33 ft-lb)

A
EM
C
D
E
F
G
H
I
J
K
L
M
N
O
P

TIMING CHAIN

< REMOVAL AND INSTALLATION >

- d. Place a paint mark (A) on crankshaft pulley (1) aligning with the angle mark (B) on crankshaft pulley bolt (2). Tighten the bolt 90 degrees (angle tightening).

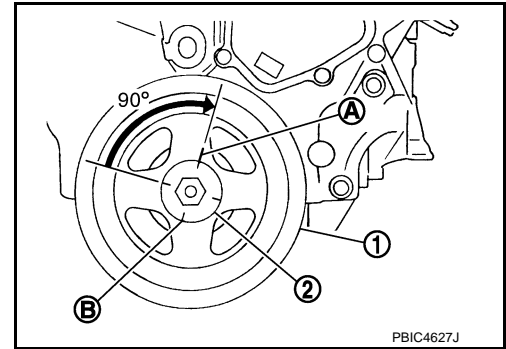

15. Rotate crankshaft pulley in normal direction (clockwise when viewed from engine front) to confirm it turns smoothly.
 16. Install in the reverse order of removal after this step.

Inspection

INFOID:000000006260633

INSPECTION AFTER REMOVAL

Timing Chain

Check for cracks and any excessive wear at link plates and roller links of timing chain. Replace timing chain if necessary.

- A : Crack
 B : Wear

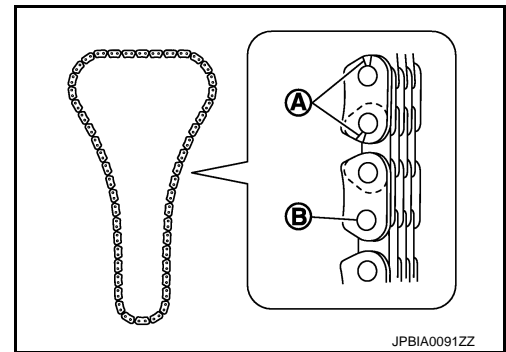

INSPECTION AFTER INSTALLATION

Inspection for Leakage

The following are procedures for checking fluids leakage and lubricates leakage.

- Before starting engine, check oil/fluid levels including engine coolant and engine oil. If less than required quantity, fill to the specified level. Refer to [MA-15. "FOR NORTH AMERICA : Fluids and Lubricants"](#) (for North America) or [MA-16. "FOR MEXICO : Fluids and Lubricants"](#) (for Mexico).
- Use procedure below to check for fuel leakage.
 - Turn ignition switch "ON" (with engine stopped). With fuel pressure applied to fuel piping, check for fuel leakage at connection points.
 - Start engine. With engine speed increased, check again for fuel leakage at connection points.
- Run engine to check for unusual noise and vibration.

NOTE:

If hydraulic pressure inside chain tensioner drops after removal/installation, slack in guide may generate a pounding noise during and just after the engine start. However, this does not indicate an unusualness. Noise will stop after hydraulic pressure rises.

- Warm up engine thoroughly to check there is no leakage of fuel, or any oil/fluids including engine oil and engine coolant.
- Bleed air from lines and hoses of applicable lines, such as in cooling system.
- After cooling down engine, again check oil/fluid levels including engine oil and engine coolant. Refill to the specified level, if necessary.

Summary of the inspection items:

Items	Before starting engine	Engine running	After engine stopped
Engine coolant	Level	Leakage	Level
Engine oil	Level	Leakage	Level

TIMING CHAIN

< REMOVAL AND INSTALLATION >

Transmission / transaxle fluid	AT & CVT Models	Leakage	Level / Leakage	Leakage
	MT Models	Level / Leakage	Leakage	Level / Leakage
Other oils and fluids*		Level	Leakage	Level
Fuel		Leakage	Leakage	Leakage
Exhaust gases		—	Leakage	—

A

EM

C

D

E

F

G

H

I

J

K

L

M

N

O

P

*: Power steering fluid, brake fluid, etc.

ENGINE ASSEMBLY

< UNIT REMOVAL AND INSTALLATION >

UNIT REMOVAL AND INSTALLATION

ENGINE ASSEMBLY

2WD

2WD : Exploded View

INFOID:000000006260634

Without Vacuum Tube (Rear) Models

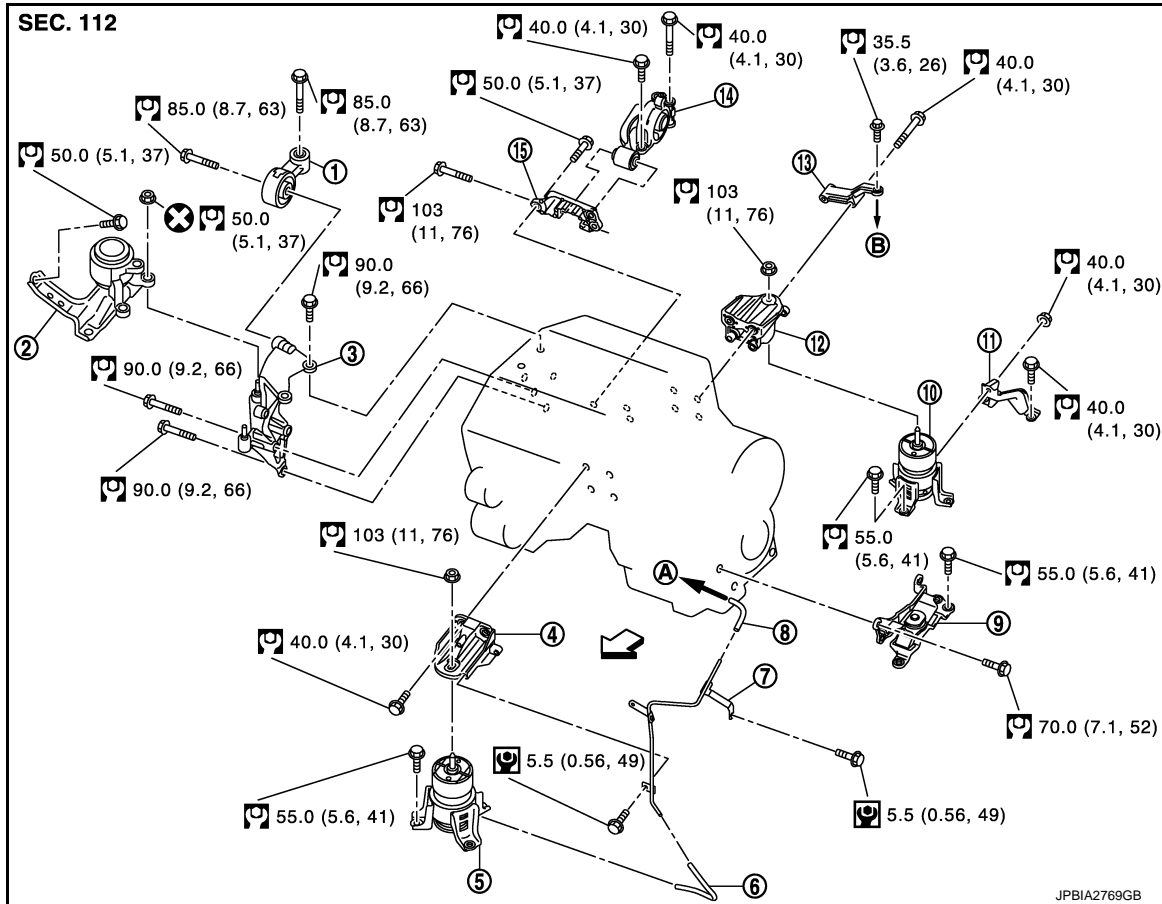

- | | | |
|--------------------------------------|--------------------------------------|------------------------------------|
| 1. Upper torque rod | 2. Engine mounting insulator (RH) | 3. Engine mounting bracket (RH) |
| 4. Engine mounting bracket (front) | 5. Engine mounting insulator (front) | 6. Vacuum hose |
| 7. Vacuum tube (front) | 8. Vacuum hose | 9. Engine mounting insulator (LH) |
| 10. Engine mounting insulator (rear) | 11. Engine mounting stay (rear) | 12. Engine mounting bracket (rear) |
| 13. Gusset | 14. Rear torque rod | 15. Rear torque rod bracket |
- A. To electronic controlled engine mount control solenoid valve
 B. To transaxle

← : Vehicle front

Refer to [GI-4, "Components"](#) for symbols in the figure.

ENGINE ASSEMBLY

< UNIT REMOVAL AND INSTALLATION >

With Vacuum Tube (Rear) Models

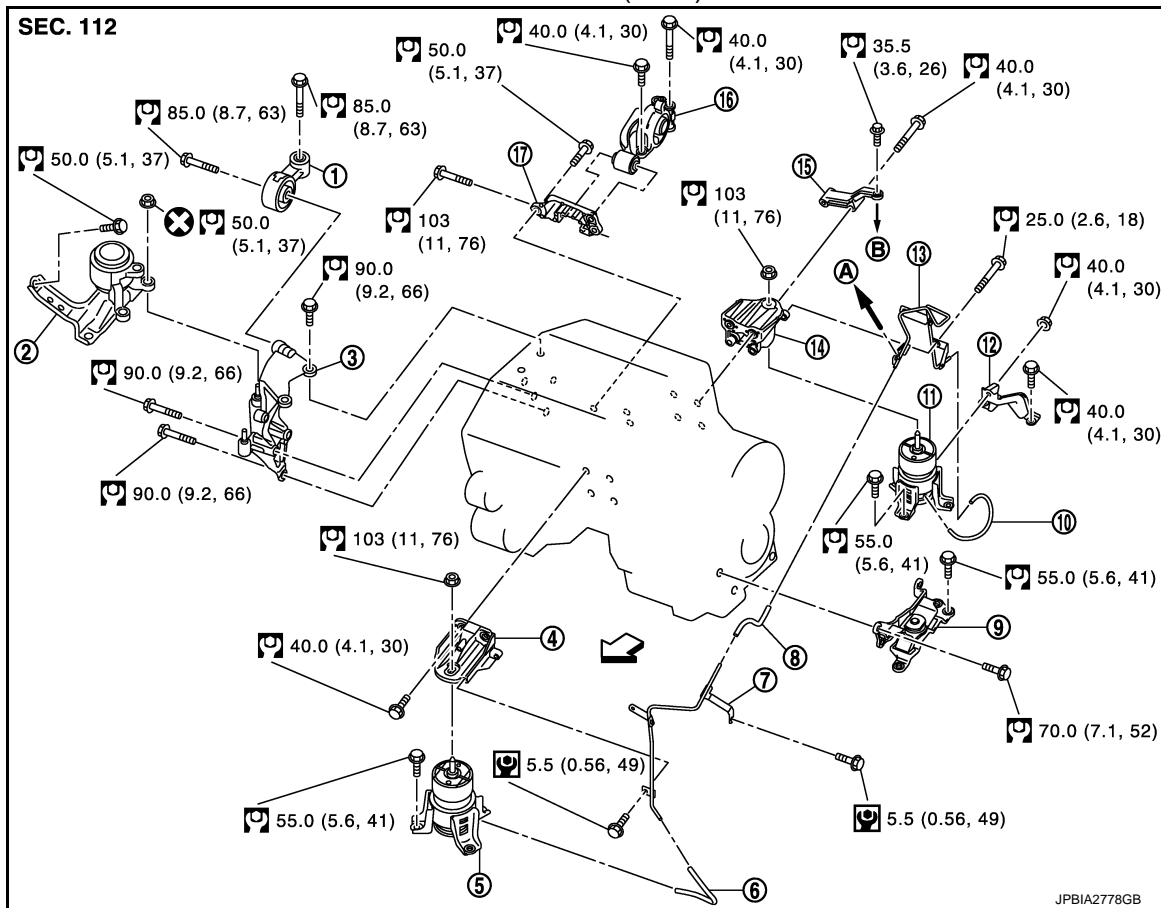

- | | | |
|------------------------------------|--------------------------------------|-----------------------------------|
| 1. Upper torque rod | 2. Engine mounting insulator (RH) | 3. Engine mounting bracket (RH) |
| 4. Engine mounting bracket (front) | 5. Engine mounting insulator (front) | 6. Vacuum hose |
| 7. Vacuum tube (front) | 8. Vacuum hose | 9. Engine mounting insulator (LH) |
| 10. Vacuum hose | 11. Engine mounting insulator (rear) | 12. Engine mounting stay (rear) |
| 13. Vacuum tube (rear) | 14. Engine mounting bracket (rear) | 15. Gusset |
| 16. Rear torque rod | 17. Rear torque rod bracket | |
- A. To electronic controlled engine mount control solenoid valve
 B. To transaxle

← : Vehicle front

Refer to [GI-4. "Components"](#) for symbols in the figure.

2WD : Removal and Installation

INFOID:000000006260635

WARNING:

- Situate the vehicle on a flat and solid surface.
- Place chocks at front and back of rear wheels.
- For engines not equipped with engine slingers, attach proper slingers and bolts described in PARTS CATALOG.

CAUTION:

- Always be careful to work safely, avoid forceful or uninstructed operations.
- Never start working until exhaust system and engine coolant are cool enough.
- If items or work required are not covered by the engine section, refer to the applicable sections.
- Always use the support point specified for lifting.
- Use either 2-pole lift type or separate type lift as best you can. If board-on type is used for unavoidable reasons, support at the rear axle jacking point with transmission jack or similar tool before starting work, in preparation for the backward shift of center of gravity.
- For supporting points for lifting and jacking point at rear axle, refer to [GI-35. "Garage Jack and Safety Stand and 2-Pole Lift"](#).

ENGINE ASSEMBLY

< UNIT REMOVAL AND INSTALLATION >

NOTE:

When removing components such as hoses, tubes/lines, etc., cap or plug openings to prevent fluid from spilling.

REMOVAL

Outline

At first, remove the engine and the transaxle assembly with front suspension member downward. Then separate the engine and the transaxle.

Preparation

1. Release fuel pressure. Refer to [EC-546, "Inspection"](#).
2. Drain engine coolant. Refer to [CO-11, "Draining"](#).
CAUTION:
 - Perform this step when the engine is cold.
 - Never spill engine coolant on drive belt.
3. Remove the following parts:
 - Engine cover: Refer to [EM-29, "Exploded View"](#).
 - Front road wheel and tires
 - Splash guards (RH and LH): Refer to [EXT-23, "FENDER PROTECTOR : Exploded View"](#).
 - Air duct (inlet), air cleaner cases (upper and lower) with mass air flow sensor and air duct assembly: Refer to [EM-31, "Exploded View"](#).
 - Battery and battery tray: Refer to [PG-118, "Removal and Installation"](#).
 - Drive belt: Refer to [EM-17, "Removal and Installation"](#).
 - Reservoir tank of radiator: Refer to [CO-16, "Exploded View"](#).
 - Front wiper arm and extension cowl top: Refer to [WW-117, "Exploded View"](#) and [EXT-20, "Exploded View"](#).
4. Disconnect engine room harness at the TCM, ECM, and other sides.
CAUTION:
To keep clean harness connector and avoid damage and foreign materials, cover them completely with plastic bags or something similar.
5. Remove battery bracket with ECM and TCM.
6. Remove sub-tank bracket mounting nut, and then temporarily secure sub-tank and bracket assembly to aside. Refer to [BR-26, "Exploded View"](#).

Engine Room

1. Disconnect heater hoses. Refer to [CO-28, "Exploded View"](#).
2. Remove EVAP hose. Refer to [EM-33, "Exploded View"](#).
3. Disconnect fuel feed hose quick connector at fuel tube side. Refer to [EM-49, "Exploded View"](#).
4. Disconnect transaxle shift control cable at transaxle side. Refer to [TM-165, "Exploded View"](#).
5. Disconnect brake booster vacuum hose at engine side. Refer to [EM-33, "Exploded View"](#).
6. Disconnect ground cable.
7. Remove A/C compressor with piping connected, and temporarily secure it to aside. Refer to [HA-37, "Exploded View"](#).
8. Disconnect suction hoses of power steering oil pump at reservoir tank side. Refer to [ST-56, "Exploded View"](#).
9. Disconnect CVT fluid cooler hoses from radiator. Refer to [CO-16, "Exploded View"](#).
10. Remove starter motor. Refer to [STR-16, "Exploded View"](#).

Vehicle Underbody

1. Remove front drive shafts (RH and LH). Refer to [FAX-17, "Exploded View"](#).
2. Remove air guide. Refer to [FSU-16, "Removal and Installation"](#).
3. Remove exhaust front tube. Refer to [EX-5, "Exploded View"](#).
4. Remove heat insulator.
5. Disconnect steering lower joint at power steering gear assembly side, and release steering lower shaft. Refer to [ST-41, "Exploded View"](#).
6. Disconnect front stabilizer connecting rod. Refer to [FSU-14, "Exploded View"](#).

ENGINE ASSEMBLY

< UNIT REMOVAL AND INSTALLATION >

7. Remove strut assembly and steering knuckle fixing nuts and bolts. Refer to [FSU-9. "Exploded View"](#) and [FAX-10. "Exploded View"](#).
8. Remove front wheel sensor (RH and LH) for ABS from steering knuckle. Refer to [BRC-119. "FRONT WHEEL SENSOR : Exploded View"](#).
9. Remove front brake caliper assembly with piping connected, and temporarily secure it to aside for vehicle side. Refer to [BR-35. "BRAKE CALIPER ASSEMBLY : Exploded View"](#).
10. Disconnect power steering piping at a point between vehicle and engine. Refer to [ST-62. "Exploded View"](#).
11. Remove rear plate cover from oil pan (upper). Then remove bolts fixing drive plate to torque converter. Refer to [EM-43. "Exploded View"](#) and [TM-174. "Removal and Installation"](#).
12. Remove transaxle joint bolts which pierce at oil pan (upper) lower rear side. Refer to [EM-43. "Exploded View"](#).
13. Remove crankshaft position sensor (POS). Refer to [EM-43. "Exploded View"](#).
CAUTION:
 - Handle carefully to avoid dropping and shocks.
 - Never disassemble.
 - Never allow metal powder to adhere to magnetic part at sensor tip.
 - Never place sensors in a location where they are exposed to magnetism.

Removal

1. Use a manual lift table caddy (commercial service tool) or equivalently rigid tool such as a transmission jack. Securely support bottom of front suspension member.

CAUTION:

Put a piece of wood or something similar as the supporting surface, secure a completely stable condition.

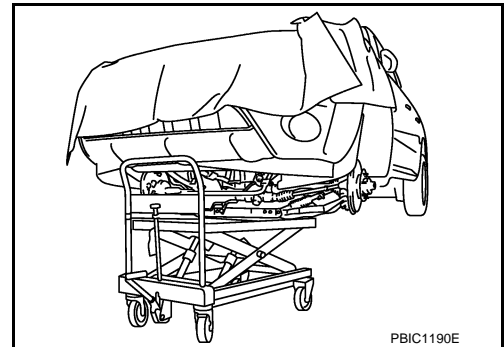

2. Remove engine mounting insulator (RH) and engine mounting bracket (RH).
3. Remove mounting bolt between transverse link and front suspension member with power tool.
4. Remove front suspension member mounting nuts and bolts. Refer to [FSU-16. "Exploded View"](#).
5. Carefully lower jack, or raise lift to remove the engine and the transaxle assembly and front suspension member. When performing work, observe the following caution:
CAUTION:
 - Confirm there is no interference with the vehicle.
 - Check all connection points have been disconnected.
 - Keep in mind the center of vehicle gravity changes. If necessary, use jack(s) to support the vehicle at rear jacking point(s) to prevent it from falling off the lift.

Separation

ENGINE ASSEMBLY

< UNIT REMOVAL AND INSTALLATION >

1. Install engine slingers into front of cylinder head (bank 1) (3) and rear of cylinder head (bank 2) (2).

- 1 : Engine rear slinger
- 4 : Engine front slinger (upper)
- 5 : Engine front slinger (lower)
- ⇐ : Engine front

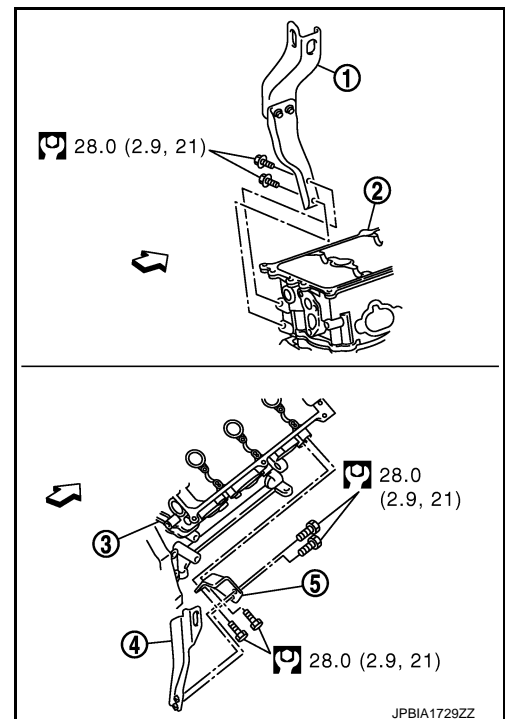

2. Remove power steering oil pump, power steering piping and power steering bracket from engine and transaxle assembly. Refer to [ST-56, "Exploded View"](#).
3. Disconnect vacuum hoses of front engine mounting insulator.
4. Disconnect vacuum hoses of rear engine mounting insulator. [With Vacuum Tube (Rear) Models]
5. Lift with hoist the engine and the transaxle assembly and front suspension member.
CAUTION:
 - Before and during this lifting, always check if any harnesses are left connected.
 - Avoid damage to and oil/grease smearing or spills onto engine mounting insulator.
6. Remove rear torque rod and rear torque rod bracket.
7. Remove each engine mounting insulator and each engine mounting bracket from engine, transaxle and front suspension member.
8. Separate engine and transaxle assembly from front suspension member.
CAUTION:
 - Before and during this lifting, always check if any harnesses are left connected.
 - Avoid damage to and oil/grease smearing or spills onto engine mounting insulator.
9. Separate engine and transaxle assembly. Refer to [TM-174, "Exploded View"](#).

INSTALLATION

Note the following, and install in the reverse order of removal.

CAUTION:

- Never allow engine mounting insulator to be damage and careful no oil gets on it.
- Check all mounting insulators are seated properly, then tighten mounting nuts and bolts.

Preparation

1. Install the engine mounting bracket (RH) to the engine as follows:

ENGINE ASSEMBLY

< UNIT REMOVAL AND INSTALLATION >

- a. Tighten the bolt No. 7 as shown in the figure. (temporarily)

↔ : Vehicle front

- b. Tighten the bolts in numerical order as shown in the figure. (specified torque)

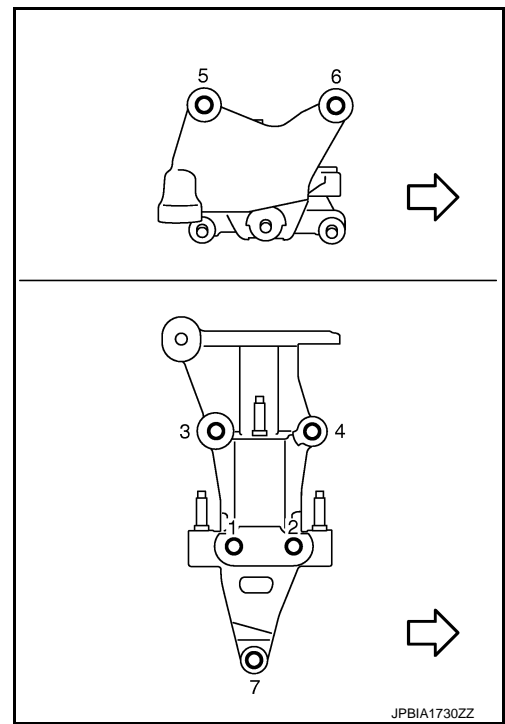

2. Install the engine mounting bracket (front) to the engine as follows:

- a. Tighten the bolt No. 4 as shown in the figure. (temporarily)

↔ : Engine front

- b. Tighten the bolts in numerical order as shown in the figure. (specified torque)

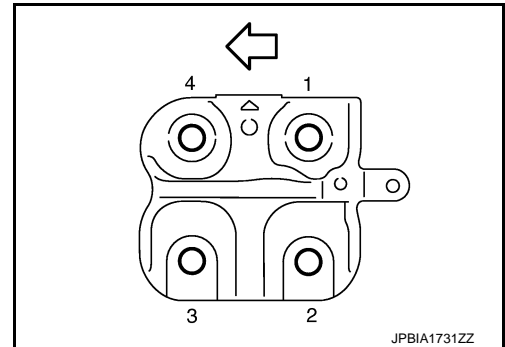

3. Install the engine mounting bracket (rear) and gusset to the engine as follows:

- a. Tighten the bolt No. 4 as shown in the figure. (temporarily)

↔ : Engine front

- b. Tighten the bolts in numerical order as shown in the figure. (specified torque)

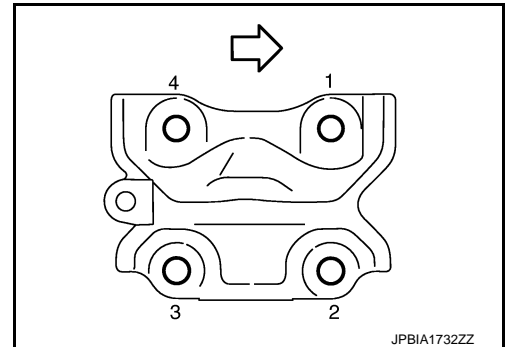

4. Install the rear torque rod bracket to the engine as follows:

A
EM
C
D
E
F
G
H
I
J
K
L
M
N
O
P

ENGINE ASSEMBLY

< UNIT REMOVAL AND INSTALLATION >

- a. Tighten the bolt No. 3 as shown in the figure. (temporarily)

⇐ : Engine front

- b. Tighten the bolts in numerical order as shown in the figure. (specified torque)

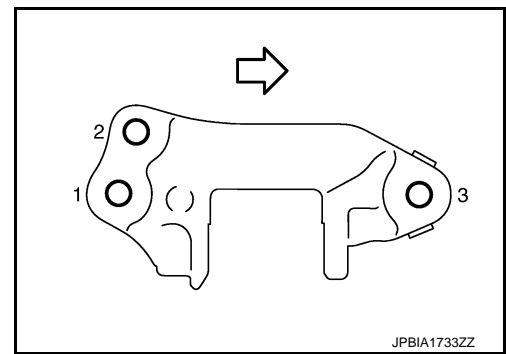

5. Install the engine mounting insulator (LH) to the transaxle as follows:

- a. Tighten the bolt No. 3 as shown in the figure. (temporarily)

⇐ : Vehicle front

- b. Tighten the bolts in numerical order as shown in the figure. (specified torque)

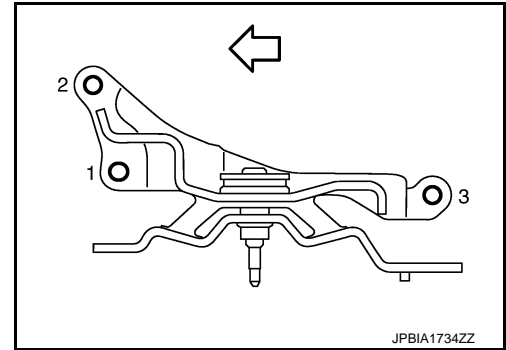

6. Install the engine mounting insulator (front) to the front suspension member as follows:

- a. Tighten the bolt No. 3 as shown in the figure. (temporarily)

⇐ : Vehicle front

- b. Tighten the bolts in numerical order as shown in the figure. (specified torque)

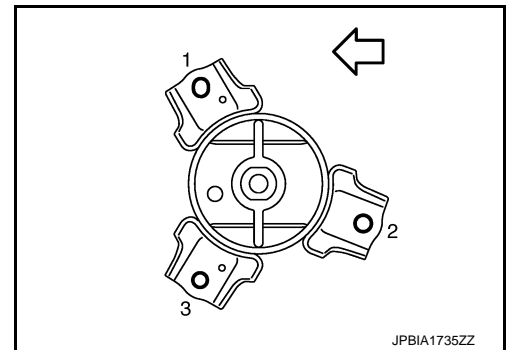

7. Install the engine mounting insulator (rear) to the front suspension member as follows:

- a. Tighten the bolt No. 3 as shown in the figure. (temporarily)

⇐ : Vehicle front

- b. Tighten the bolts in numerical order as shown in the figure. (specified torque)

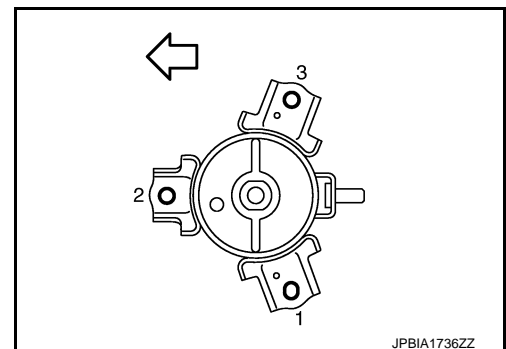

8. Install the engine mounting stay (rear) as follows:

ENGINE ASSEMBLY

< UNIT REMOVAL AND INSTALLATION >

- a. Tighten the nut No. 3 as shown in the figure. (temporarily)

← : Vehicle front

- b. Tighten the bolts and nut in numerical order as shown in the figure. (specified torque)

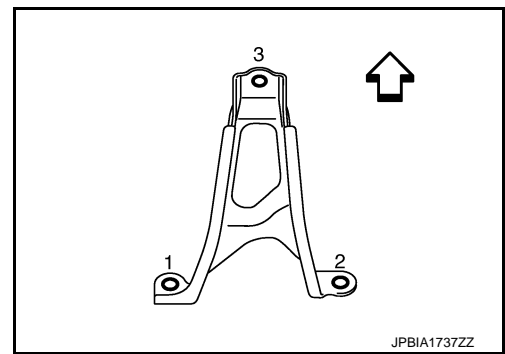

9. Install the rear torque rod to the front suspension member as follows:

- a. Tighten the bolt No. 3 as shown in the figure. (temporarily)

← : Vehicle front

- b. Tighten the bolts in numerical order as shown in the figure. (specified torque)

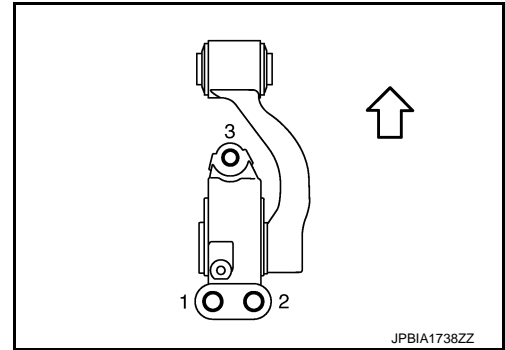

10. Install the engine mounting brackets (front and rear) to the engine mounting insulators (front and rear).

11. Install the engine mounting insulator (LH) to the front suspension member.

- Tighten the bolts in numerical order as shown in the figure.

← : Vehicle front

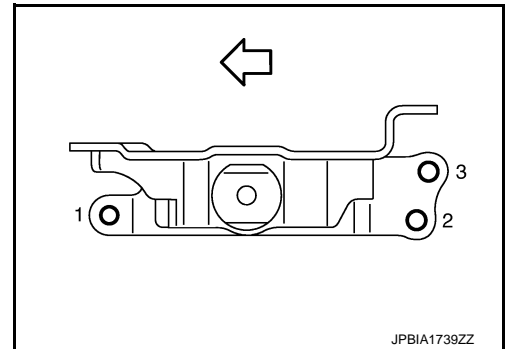

12. Install the rear torque rod to the rear torque rod bracket.

13. Install the vacuum tube (front) as follows:

- a. Tighten the bolt No. 3 as shown in the figure. (temporarily)

← : Engine front

- b. Tighten the bolts in numerical order as shown in the figure. (specified torque)

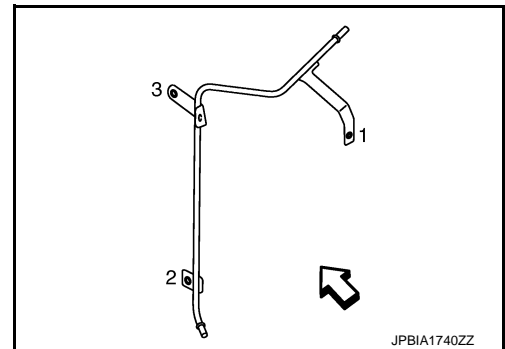

With vacuum tube (rear) models

14. Install the vacuum tube (rear) as follows:

ENGINE ASSEMBLY

< UNIT REMOVAL AND INSTALLATION >

- a. Tighten the bolt No. 3 as shown in the figure. (temporarily)

⇐ : Engine front

- b. Tighten the bolts in numerical order as shown in the figure. (specified torque)

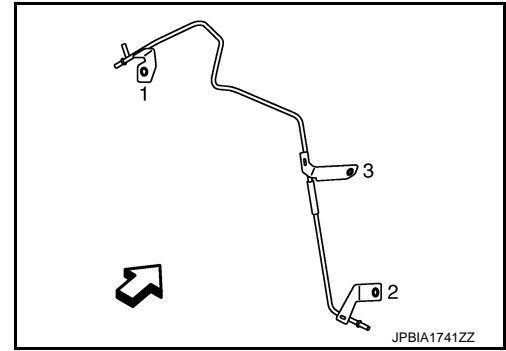

Installation

1. Install the engine mounting insulator (RH) as follows:

- a. Tighten the bolt No. 1 as shown in the figure. (temporarily)

⇐ : Vehicle front

- b. Tighten the bolts No. 2, 3 in numerical order as shown in the figure. (specified torque)
- c. Tighten the bolt No. 1 as shown in the figure. (specified torque)
- d. Tighten the bolts No. 4, 5, 6 in numerical order as shown in the figure. (specified torque)

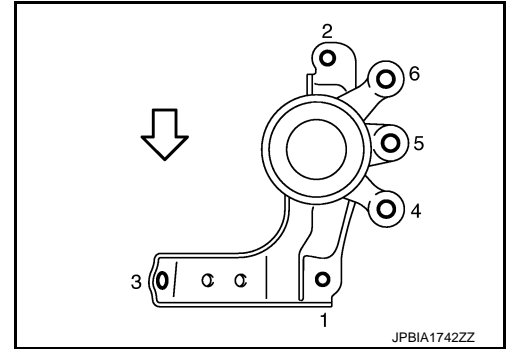

2. Install the upper torque rod as follows:

- a. Tighten the bolt No. 2 as shown in the figure. (temporarily)

⇐ : Vehicle front

- b. Tighten the bolts in numerical order as shown in the figure. (specified torque)

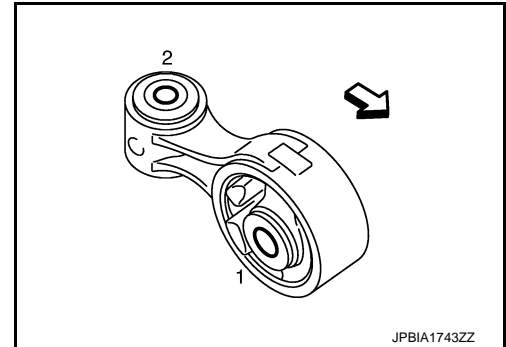

2WD : Inspection

INFOID:000000006260636

INSPECTION AFTER INSTALLATION

Inspection for Leakage

The following are procedures for checking fluids leakage, lubricates leakage, and exhaust gases leakage.

- Before starting engine, check oil/fluid levels including engine coolant and engine oil. If less than required quantity, fill to the specified level. Refer to [MA-15, "FOR NORTH AMERICA : Fluids and Lubricants"](#) (for North America) or [MA-16, "FOR MEXICO : Fluids and Lubricants"](#) (for Mexico).
- Use procedure below to check for fuel leakage.
 - Turn ignition switch "ON" (with engine stopped). With fuel pressure applied to fuel piping, check for fuel leakage at connection points.
 - Start engine. With engine speed increased, check again for fuel leakage at connection points.
- Run engine to check for unusual noise and vibration.
- Warm up engine thoroughly to check there is no leakage of fuel, exhaust gases, or any oil/fluids including engine oil and engine coolant.
- Bleed air from lines and hoses of applicable lines, such as in cooling system.
- After cooling down engine, again check oil/fluid levels including engine oil and engine coolant. Refill to the specified level, if necessary.

ENGINE ASSEMBLY

< UNIT REMOVAL AND INSTALLATION >

Summary of the inspection items:

Items		Before starting engine	Engine running	After engine stopped
Engine coolant		Level	Leakage	Level
Engine oil		Level	Leakage	Level
Transmission / transaxle fluid	AT & CVT Models	Leakage	Level / Leakage	Leakage
	MT Models	Level / Leakage	Leakage	Level / Leakage
Other oils and fluids*		Level	Leakage	Level
Fuel		Leakage	Leakage	Leakage
Exhaust gases		—	Leakage	—

*: Power steering fluid, brake fluid, etc.

AWD

AWD : Exploded View

INFOID:000000006260637

Without Vacuum Tube (Rear) Models

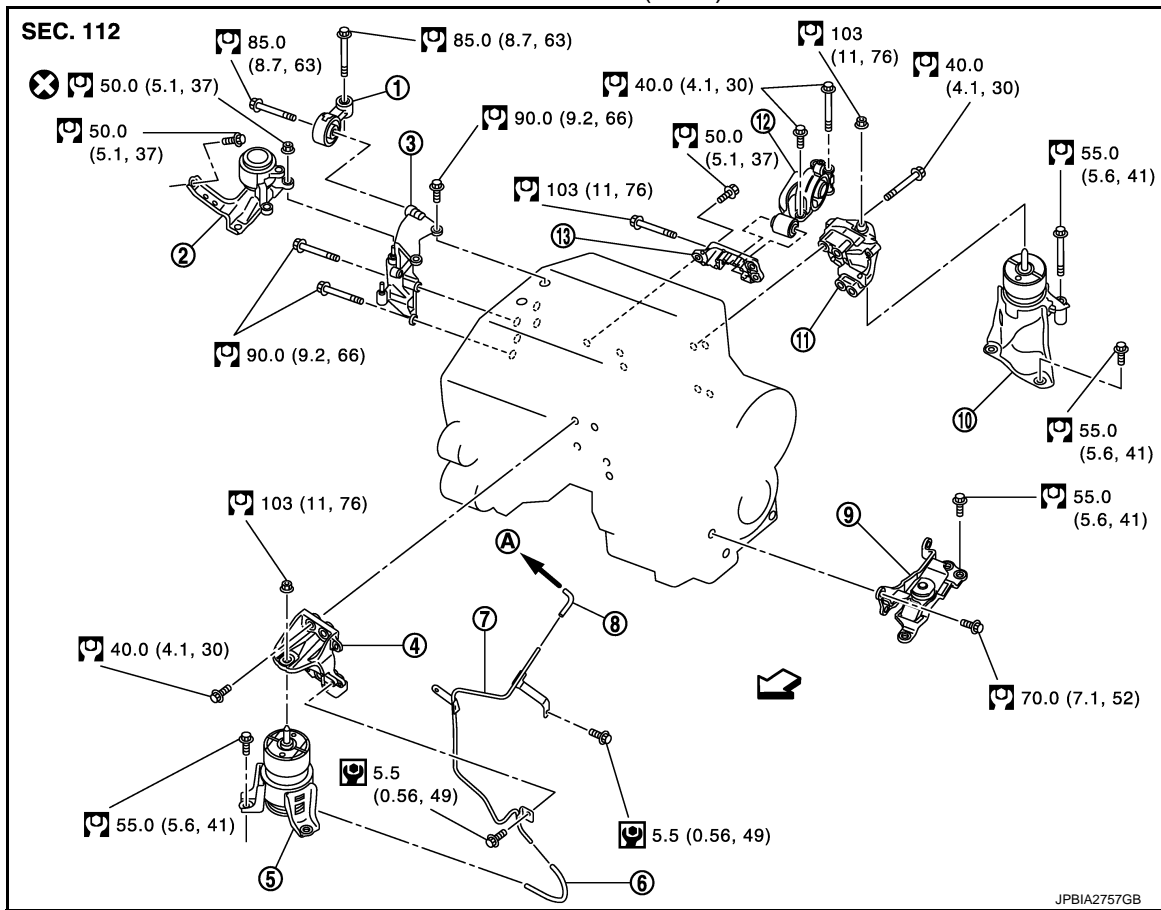

- 1. Upper torque rod
- 2. Engine mounting insulator (RH)
- 3. Engine mounting bracket (RH)
- 4. Engine mounting bracket (front)
- 5. Engine mounting insulator (front)
- 6. Vacuum hose
- 7. Vacuum tube (front)
- 8. Vacuum hose
- 9. Engine mounting insulator (LH)
- 10. Engine mounting insulator (rear)
- 11. Vacuum hose
- 12. Rear torque rod
- 13. Rear torque rod bracket

A. To electronic controlled engine mount control solenoid valve

← : Vehicle front

Refer to [GI-4. "Components"](#) for symbols in the figure.

ENGINE ASSEMBLY

< UNIT REMOVAL AND INSTALLATION >

With Vacuum Tube (Rear) Models

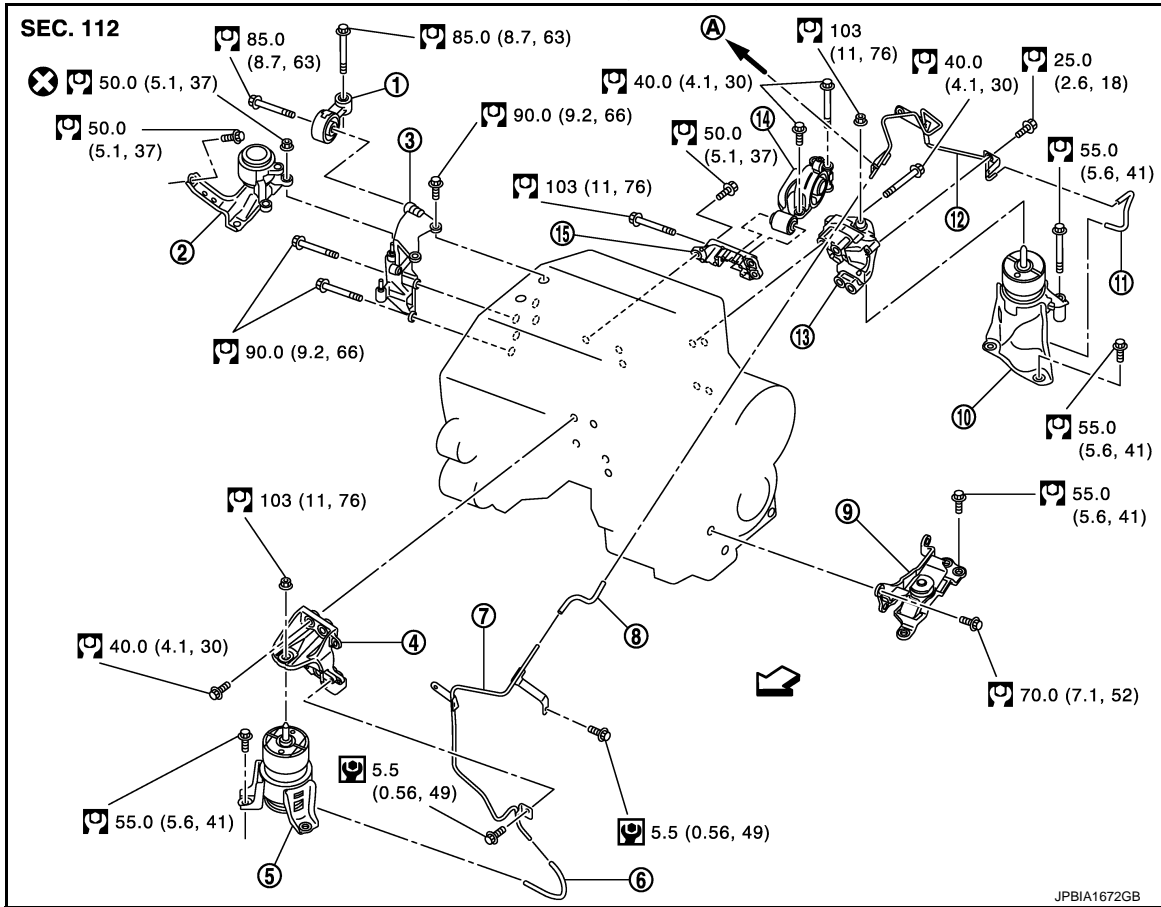

- | | | |
|--------------------------------------|--------------------------------------|-----------------------------------|
| 1. Upper torque rod | 2. Engine mounting insulator (RH) | 3. Engine mounting bracket (RH) |
| 4. Engine mounting bracket (front) | 5. Engine mounting insulator (front) | 6. Vacuum hose |
| 7. Vacuum tube (front) | 8. Vacuum hose | 9. Engine mounting insulator (LH) |
| 10. Engine mounting insulator (rear) | 11. Vacuum hose | 12. Vacuum tube (rear) |
| 13. Engine mounting bracket (rear) | 14. Rear torque rod | 15. Rear torque rod bracket |
- A. To electronic controlled engine mount control solenoid valve

← : Vehicle front

Refer to [GI-4, "Components"](#) for symbols in the figure.

AWD : Removal and Installation

INFOID:000000006260638

WARNING:

- Situate the vehicle on a flat and solid surface.
- Place chocks at front and back of rear wheels.
- For engines not equipped with engine slingers, attach proper slingers and bolts described in PARTS CATALOG.

CAUTION:

- Always be careful to work safely, avoid forceful or uninstructed operations.
- Never start working until exhaust system and engine coolant are cool enough.
- If items or work required are not covered by the engine section, refer to the applicable sections.
- Always use the support point specified for lifting.
- Use either 2-pole lift type or separate type lift as best you can. If board-on type is used for unavoidable reasons, support at the rear axle jacking point with transmission jack or similar tool before starting work, in preparation for the backward shift of center of gravity.
- For supporting points for lifting and jacking point at rear axle, refer to [GI-35, "Garage Jack and Safety Stand and 2-Pole Lift"](#).

NOTE:

ENGINE ASSEMBLY

< UNIT REMOVAL AND INSTALLATION >

When removing components such as hoses, tubes/lines, etc., cap or plug openings to prevent fluid from spilling.

REMOVAL

Outline

At first, remove the engine, the transaxle and the transfer assembly with front suspension member downward. Then separate the engine, the transaxle and the transfer.

Preparation

1. Release fuel pressure. Refer to [EC-546, "Inspection"](#).
2. Drain engine coolant. Refer to [CO-11, "Draining"](#).
CAUTION:
 - Perform this step when the engine is cold.
 - Never spill engine coolant on drive belt.
3. Remove the following parts:
 - Engine cover: Refer to [EM-29, "Exploded View"](#).
 - Front road wheel and tires
 - Splash guards (RH and LH): Refer to [EXT-23, "FENDER PROTECTOR : Exploded View"](#).
 - Air duct (inlet), air cleaner cases (upper and lower) with mass air flow sensor and air duct assembly: Refer to [EM-31, "Exploded View"](#).
 - Battery and battery tray: Refer to [PG-118, "Removal and Installation"](#).
 - Drive belt: Refer to [EM-17, "Removal and Installation"](#).
 - Reservoir tank of radiator: Refer to [CO-16, "Exploded View"](#).
 - Front wiper arm and extension cowl top: Refer to [WW-117, "Exploded View"](#) and [EXT-20, "Exploded View"](#).
4. Disconnect engine room harness at the TCM, ECM, and other sides.
CAUTION:
To keep clean harness connector and avoid damage and foreign materials, cover them completely with plastic bags or something similar.
5. Remove battery bracket with ECM and TCM.
6. Remove sub-tank bracket mounting nut, and then temporarily secure sub-tank and bracket assembly to aside. Refer to [BR-26, "Exploded View"](#).

Engine Room

1. Disconnect heater hoses. Refer to [CO-28, "Exploded View"](#).
2. Remove EVAP hose. Refer to [EM-33, "Exploded View"](#).
3. Disconnect fuel feed hose quick connector at fuel tube side. Refer to [EM-49, "Exploded View"](#).
4. Disconnect transaxle shift control cable at transaxle side. Refer to [TM-165, "Exploded View"](#).
5. Disconnect brake booster vacuum hose at engine side. Refer to [EM-33, "Exploded View"](#).
6. Disconnect ground cable.
7. Remove A/C compressor with piping connected, and temporarily secure it to aside. Refer to [HA-37, "Exploded View"](#).
8. Disconnect suction hoses of power steering oil pump at reservoir tank side. Refer to [ST-62, "Exploded View"](#).
9. Disconnect CVT fluid cooler hoses from radiator. Refer to [CO-16, "Exploded View"](#).
10. Remove starter motor. Refer to [STR-16, "Exploded View"](#).

Vehicle Underbody

1. Remove front drive shafts (RH and LH). Refer to [FAX-43, "Exploded View"](#).
2. Remove air guide. Refer to [FSU-16, "Removal and Installation"](#).
3. Remove exhaust front tube. Refer to [EX-5, "Exploded View"](#).
4. Remove propeller shaft. Refer to [DLN-82, "Exploded View"](#).
5. Remove heat insulator.
6. Disconnect steering lower joint at power steering gear assembly side, and release steering lower shaft. Refer to [ST-41, "Exploded View"](#).
7. Disconnect front stabilizer connecting rod. Refer to [FSU-14, "Exploded View"](#).

ENGINE ASSEMBLY

< UNIT REMOVAL AND INSTALLATION >

8. Remove strut assembly and steering knuckle fixing nuts and bolts. Refer to [FSU-9, "Exploded View"](#) and [FAX-36, "Exploded View"](#).
9. Remove front wheel sensor (RH and LH) for ABS from steering knuckle. Refer to [BRC-119, "FRONT WHEEL SENSOR : Exploded View"](#).
10. Remove front brake caliper assembly with piping connected, and temporarily secure it to aside for vehicle side. Refer to [BR-35, "BRAKE CALIPER ASSEMBLY : Exploded View"](#).
11. Disconnect power steering piping at a point between vehicle and engine. Refer to [ST-62, "Exploded View"](#).
12. Remove rear plate cover from oil pan (upper). Then remove bolts fixing drive plate to torque converter. Refer to [EM-43, "Exploded View"](#) and [TM-174, "Removal and Installation"](#).
13. Remove transaxle joint bolts which pierce at oil pan (upper) lower rear side. Refer to [EM-43, "Exploded View"](#).
14. Remove crankshaft position sensor (POS). Refer to [EM-43, "Exploded View"](#).
CAUTION:
 - Handle carefully to avoid dropping and shocks.
 - Never disassemble.
 - Never allow metal powder to adhere to magnetic part at sensor tip.
 - Never place sensors in a location where they are exposed to magnetism.

Removal

1. Use a manual lift table caddy (commercial service tool) or equivalently rigid tool such as a transmission jack. Securely support bottom of front suspension member.

CAUTION:

Put a piece of wood or something similar as the supporting surface, secure a completely stable condition.

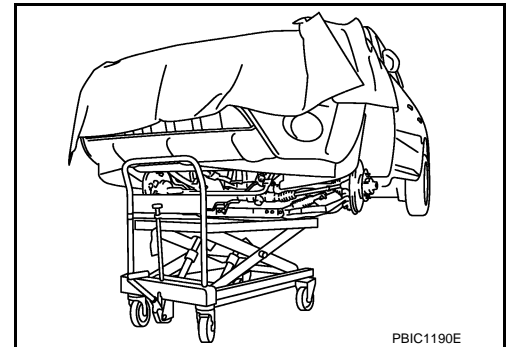

2. Remove engine mounting insulator (RH) and engine mounting bracket (RH).
3. Remove mounting bolt between transverse link and front suspension member with power tool.
4. Remove front suspension member mounting nuts and bolts. Refer to [FSU-16, "Exploded View"](#).
5. Carefully lower jack, or raise lift to remove the engine, the transaxle and transfer assembly and front suspension member. When performing work, observe the following caution:
CAUTION:
 - Confirm there is no interference with the vehicle.
 - Check all connection points have been disconnected.
 - Keep in mind the center of vehicle gravity changes. If necessary, use jack(s) to support the vehicle at rear jacking point(s) to prevent it from falling it off the lift.

Separation

ENGINE ASSEMBLY

< UNIT REMOVAL AND INSTALLATION >

1. Install engine slingers into front of cylinder head (bank 1) (3) and rear of cylinder head (bank 2) (2).

- 1 : Engine rear slinger
- 4 : Engine front slinger (upper)
- 5 : Engine front slinger (lower)
- ⇐ : Engine front

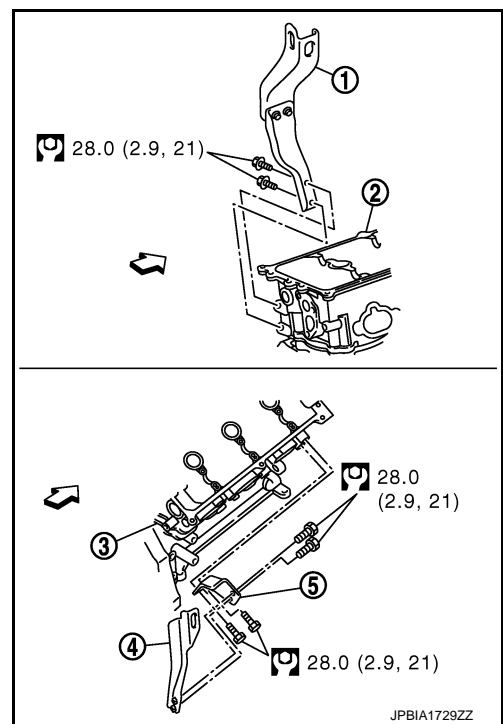

2. Remove power steering oil pump, power steering piping and power steering bracket from engine, transaxle and transfer assembly. Refer to [ST-56, "Exploded View"](#).
3. Disconnect vacuum hoses of front engine mounting insulator.
4. Disconnect vacuum hoses of rear engine mounting insulator. [With Vacuum Tube (rear) Models]
5. Lift with hoist the engine, the transaxle and the transfer assembly and front suspension member.
CAUTION:
 - Before and during this lifting, always check if any harnesses are left connected.
 - Avoid damage to and oil/grease smearing or spills onto engine mounting insulator.
6. Remove rear torque rod and rear torque rod bracket.
7. Remove each engine mounting insulator and each engine mounting bracket from engine, transaxle and front suspension member.
8. Separate engine, transaxle and transfer assembly from front suspension member.
CAUTION:
 - Before and during this lifting, always check if any harnesses are left connected.
 - Avoid damage to and oil/grease smearing or spills onto engine mounting insulator.
9. Remove exhaust manifold. Refer to [EM-38, "Exploded View"](#).
10. Remove transfer. Refer to [DLN-53, "Exploded View"](#).
11. Separate engine and transaxle assembly. Refer to [TM-174, "Exploded View"](#).

INSTALLATION

Note the following, and install in the reverse order of removal.

CAUTION:

- Never allow engine mounting insulator to be damage and careful no oil gets on it.
- Check all mounting insulators are seated properly, then tighten mounting nuts and bolts.

Preparation

1. Install the engine mounting bracket (RH) to the engine as follows:

ENGINE ASSEMBLY

< UNIT REMOVAL AND INSTALLATION >

- a. Tighten the bolt No. 7 as shown in the figure. (temporarily)

⇐ : Vehicle front

- b. Tighten the bolts in numerical order as shown in the figure. (specified torque)

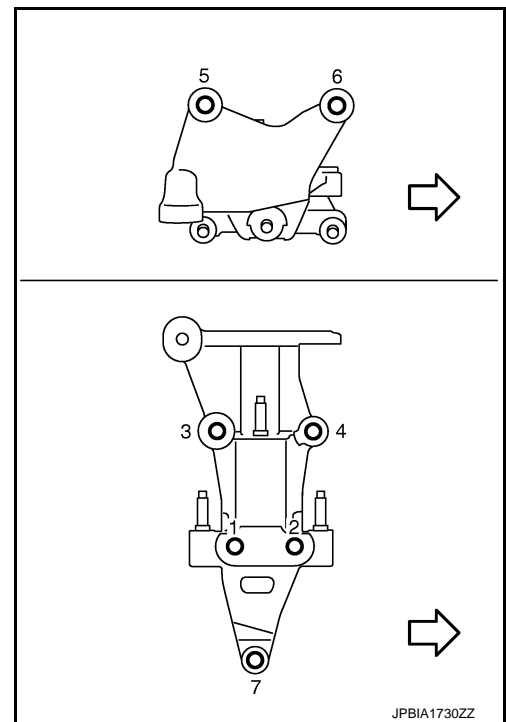

2. Install the engine mounting bracket (front) to the engine as follows:

- a. Tighten the bolt No. 4 as shown in the figure. (temporarily)

⇐ : Engine front

- b. Tighten the bolts in numerical order as shown in the figure. (specified torque)

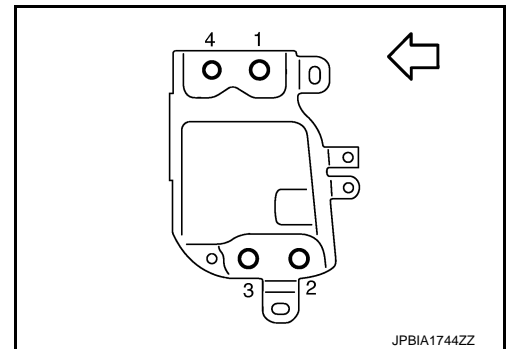

3. Install the engine mounting bracket (rear) to the engine as follows:

- a. Tighten the bolt No. 4 as shown in the figure. (temporarily)

⇐ : Engine front

- b. Tighten the bolts in numerical order as shown in the figure. (specified torque)

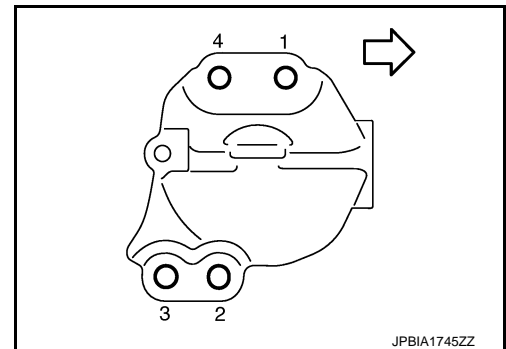

4. Install the rear torque rod bracket to the engine as follows:

ENGINE ASSEMBLY

< UNIT REMOVAL AND INSTALLATION >

- a. Tighten the bolt No. 3 as shown in the figure. (temporarily)

⇐ : Engine front

- b. Tighten the bolts in numerical order as shown in the figure. (specified torque)

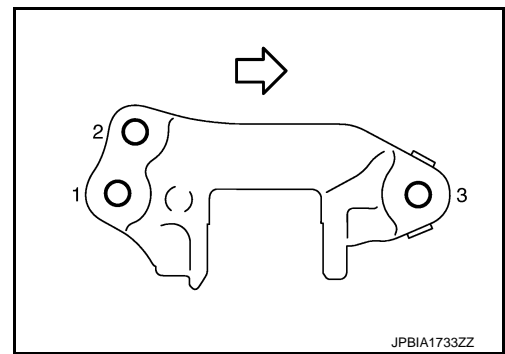

5. Install the engine mounting insulator (LH) to the transaxle as follows:

- a. Tighten the bolt No. 3 as shown in the figure. (temporarily)

⇐ : Vehicle front

- b. Tighten the bolts in numerical order as shown in the figure. (specified torque)

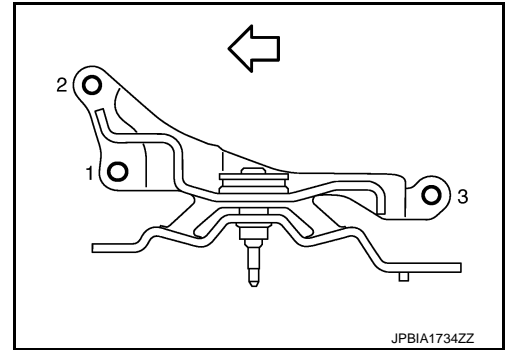

6. Install the engine mounting insulator (front) to the front suspension member as follows:

- a. Tighten the bolt No. 3 as shown in the figure. (temporarily)

⇐ : Vehicle front

- b. Tighten the bolts in numerical order as shown in the figure. (specified torque)

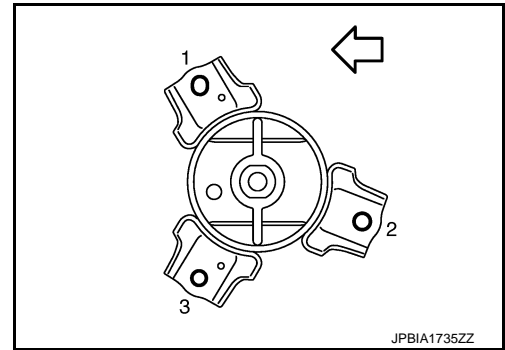

7. Install the engine mounting insulator (rear) to the front suspension member as follows:

- a. Tighten the bolt No. 4 as shown in the figure. (temporarily)

⇐ : Vehicle front

- b. Tighten the bolts in numerical order as shown in the figure. (specified torque)

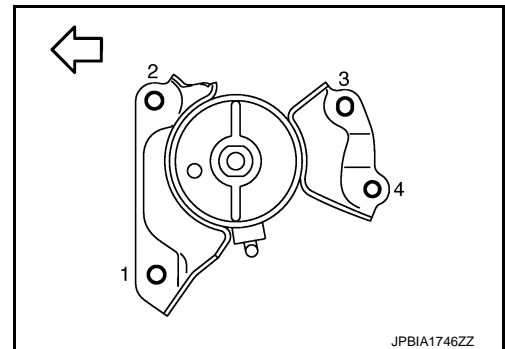

8. Install the rear torque rod to the front suspension member as follows:

A
EM
C
D
E
F
G
H
I
J
K
L
M
N
O
P

ENGINE ASSEMBLY

< UNIT REMOVAL AND INSTALLATION >

- a. Tighten the bolt No. 3 as shown in the figure. (temporarily)

⇐ : Vehicle front

- b. Tighten the bolts in numerical order as shown in the figure. (specified torque)

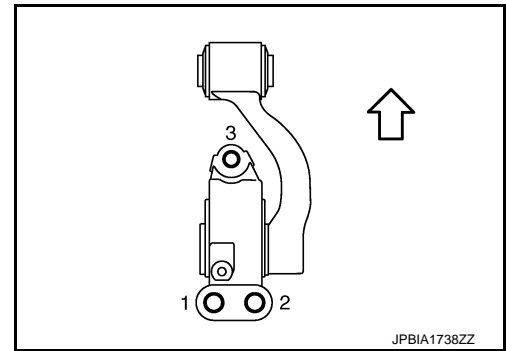

9. Install the engine mounting brackets (front and rear) to the engine mounting insulators (front and rear).
10. Install the engine mounting insulator (LH) to the front suspension member.
• Tighten the bolts in numerical order as shown in the figure.

⇐ : Vehicle front

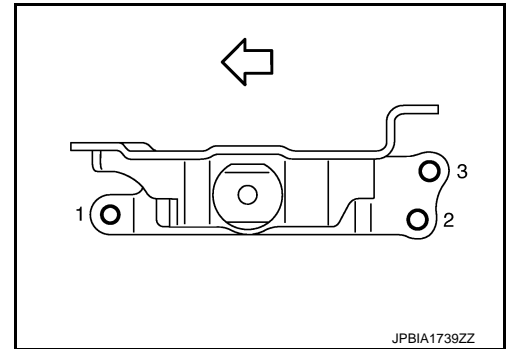

11. Install the rear torque rod to the rear torque rod bracket.
12. Install the vacuum tube (front) as follows:
a. Tighten the bolt No. 3 as shown in the figure. (temporarily)

⇐ : Engine front

- b. Tighten the bolts in numerical order as shown in the figure. (specified torque)

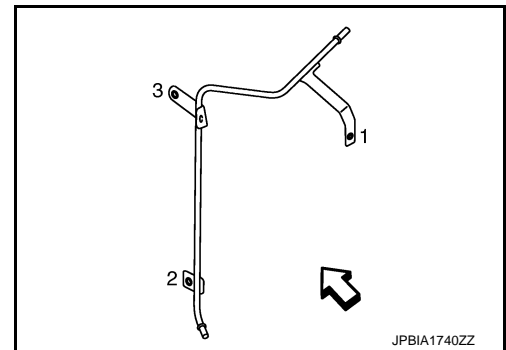

With vacuum tube (rear) models

13. Install the vacuum tube (rear) as follows:
a. Tighten the bolt No. 3 as shown in the figure. (temporarily)

⇐ : Engine front

- b. Tighten the bolts in numerical order as shown in the figure. (specified torque)

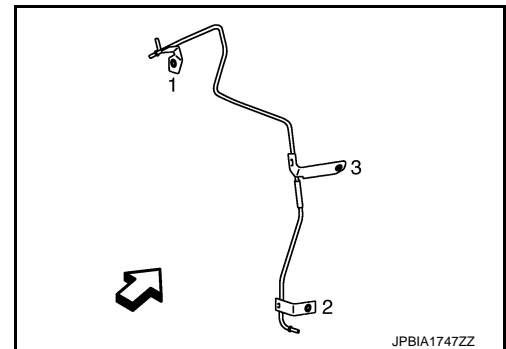

Installation

1. Install the engine mounting insulator (RH) as follows:

ENGINE ASSEMBLY

< UNIT REMOVAL AND INSTALLATION >

- a. Tighten the bolt No. 1 as shown in the figure. (temporarily)

↶ : Vehicle front

- b. Tighten the bolts No. 2, 3 in numerical order as shown in the figure. (specified torque)
 c. Tighten the bolt No. 1 as shown in the figure. (specified torque)
 d. Tighten the bolts No. 4, 5, 6 in numerical order as shown in the figure. (specified torque)

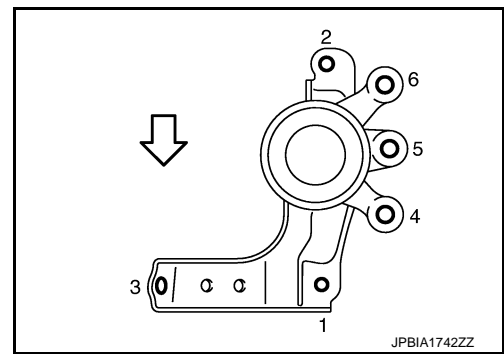

2. Install the upper torque rod as follows:

- a. Tighten the bolt No. 2 as shown in the figure. (temporarily)

↶ : Vehicle front

- b. Tighten the bolts in numerical order as shown in the figure. (specified torque)

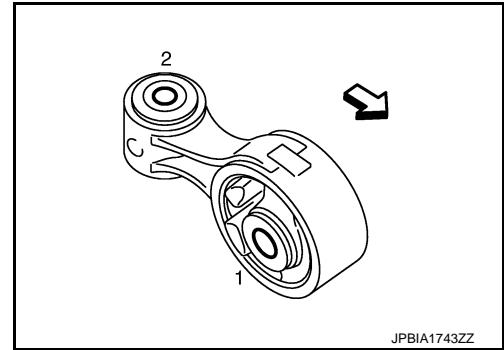

INFOID:000000006260639

AWD : Inspection

INSPECTION AFTER INSTALLATION

Inspection for Leakage

The following are procedures for checking fluids leakage, lubricates leakage, and exhaust gases leakage.

- Before starting engine, check oil/fluid levels including engine coolant and engine oil. If less than required quantity, fill to the specified level. Refer to [MA-15. "FOR NORTH AMERICA : Fluids and Lubricants"](#) (for North America) or [MA-16. "FOR MEXICO : Fluids and Lubricants"](#) (for Mexico).
- Use procedure below to check for fuel leakage.
 - Turn ignition switch "ON" (with engine stopped). With fuel pressure applied to fuel piping, check for fuel leakage at connection points.
 - Start engine. With engine speed increased, check again for fuel leakage at connection points.
- Run engine to check for unusual noise and vibration.
- Warm up engine thoroughly to check there is no leakage of fuel, exhaust gases, or any oil/fluids including engine oil and engine coolant.
- Bleed air from lines and hoses of applicable lines, such as in cooling system.
- After cooling down engine, again check oil/fluid levels including engine oil and engine coolant. Refill to the specified level, if necessary.

Summary of the inspection items:

Items		Before starting engine	Engine running	After engine stopped
Engine coolant		Level	Leakage	Level
Engine oil		Level	Leakage	Level
Transmission / transaxle fluid	AT & CVT Models	Leakage	Level / Leakage	Leakage
	MT Models	Level / Leakage	Leakage	Level / Leakage
Other oils and fluids*		Level	Leakage	Level
Fuel		Leakage	Leakage	Leakage
Exhaust gases		—	Leakage	—

*: Power steering fluid, brake fluid, etc.

ENGINE STAND SETTING

< UNIT DISASSEMBLY AND ASSEMBLY >

UNIT DISASSEMBLY AND ASSEMBLY

ENGINE STAND SETTING

Setting

INFOID:000000006260640

NOTE:

Explained here is how to disassemble with engine stand supporting transaxle surface. When using different type of engine stand, note with difference in steps and etc.

1. Remove the engine assembly from the vehicle. Refer to [EM-72, "2WD : Exploded View"](#) (2WD models) or [EM-81, "AWD : Exploded View"](#) (AWD models).
2. Remove the parts that may restrict installation of engine to widely use engine stand.

NOTE:

The procedure is described assuming that you use a widely use engine stand holding the surface, to which transaxle is installed.

- Remove drive plate. Fix crankshaft pulley with the pulley holder (commercial service tool), and remove mounting bolts.
- Loosen mounting bolts in diagonal order.
- Check for deformation or damage drive plate.

CAUTION:

- **Never disassemble drive plate.**
- **Never place drive plate with signal plate facing down.**
- **When handling signal plate, take care not to damage or scratch it.**
- **Handle signal plate in a manner that prevents it from becoming magnetized.**

3. Remove pilot converter using the pilot bushing puller (SST) if necessary.

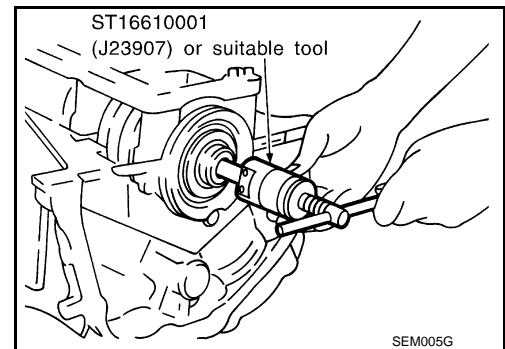

4. Lift the engine with hoist to install it onto the widely use engine stand.

CAUTION:

Use an engine stand that has a load capacity [220 kg (485 lb) or more] large enough for supporting the engine weight.

- If the load capacity of the stand is not adequate, remove the following parts beforehand to reduce the potential risk of overturning the stand.
 - Remove intake manifold collector. Refer to [EM-33, "Exploded View"](#).
 - Remove intake manifold. Refer to [EM-36, "Exploded View"](#).
 - Remove fuel injector and fuel tube assembly. Refer to [EM-49, "Exploded View"](#).
 - Remove ignition coil. Refer to [EM-54, "Exploded View"](#).
 - Remove rocker cover. Refer to [EM-54, "Exploded View"](#).
 - Remove exhaust manifold. Refer to [EM-38, "Exploded View"](#).
 - Other removable brackets.

NOTE:

ENGINE STAND SETTING

< UNIT DISASSEMBLY AND ASSEMBLY >

The figure shows an example of widely use engine stand (A) that can hold mating surface of transaxle with drive plate removed.

CAUTION:

Before removing the hanging chains, check the engine stand is stable and there is no risk of overturning.

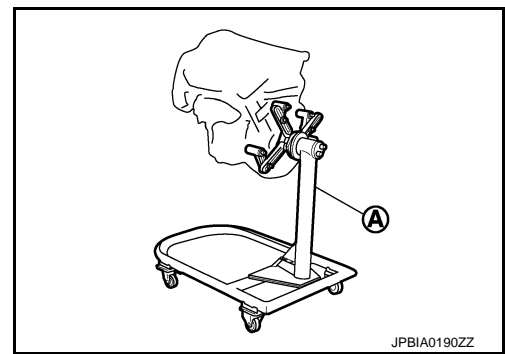

5. Drain engine oil. Refer to [LU-8. "Draining"](#).
6. Drain engine coolant by removing water drain plugs (A) and (B) from cylinder block both sides as shown in the figure.

C : Plug

D : Connector bolt

Tightening torque : Refer to [EM-123. "Disassembly and Assembly"](#).

NOTE:

For Canada, water drain plug (A) in the figure is not water drain plug but block heater. Refer to [EM-122. "Exploded View"](#).

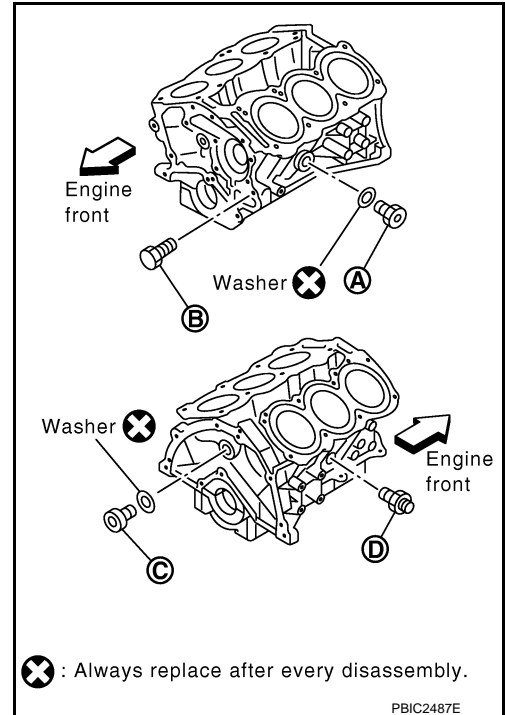

A
EM
C
D
E
F
G
H
I
J
K
L
M
N
O
P

ENGINE UNIT

< UNIT DISASSEMBLY AND ASSEMBLY >

ENGINE UNIT

Disassembly

INFOID:000000006260641

1. Remove intake manifold collector. Refer to [EM-33, "Exploded View"](#).
2. Remove intake manifold. Refer to [EM-36, "Exploded View"](#).
3. Remove exhaust manifold. Refer to [EM-38, "Exploded View"](#).
4. Remove oil pan (lower and upper). Refer to [EM-43, "Exploded View"](#).
5. Remove ignition coil, spark plug and rocker cover. Refer to [EM-54, "Exploded View"](#).
6. Remove fuel injector and fuel tube. Refer to [EM-49, "Exploded View"](#).
7. Remove timing chain and rear timing chain case. Refer to [EM-57, "Exploded View"](#) and [EM-93, "Exploded View"](#).
8. Remove camshaft. Refer to [EM-98, "Exploded View"](#).
9. Remove cylinder head. Refer to [EM-111, "Exploded View"](#).

Assembly

INFOID:000000006260642

Assembly in the reverse order of disassembly.

REAR TIMING CHAIN CASE

< UNIT DISASSEMBLY AND ASSEMBLY >

REAR TIMING CHAIN CASE

Exploded View

INFOID:000000006260643

A

EM

C

D

E

F

G

H

I

J

K

L

M

N

O

P

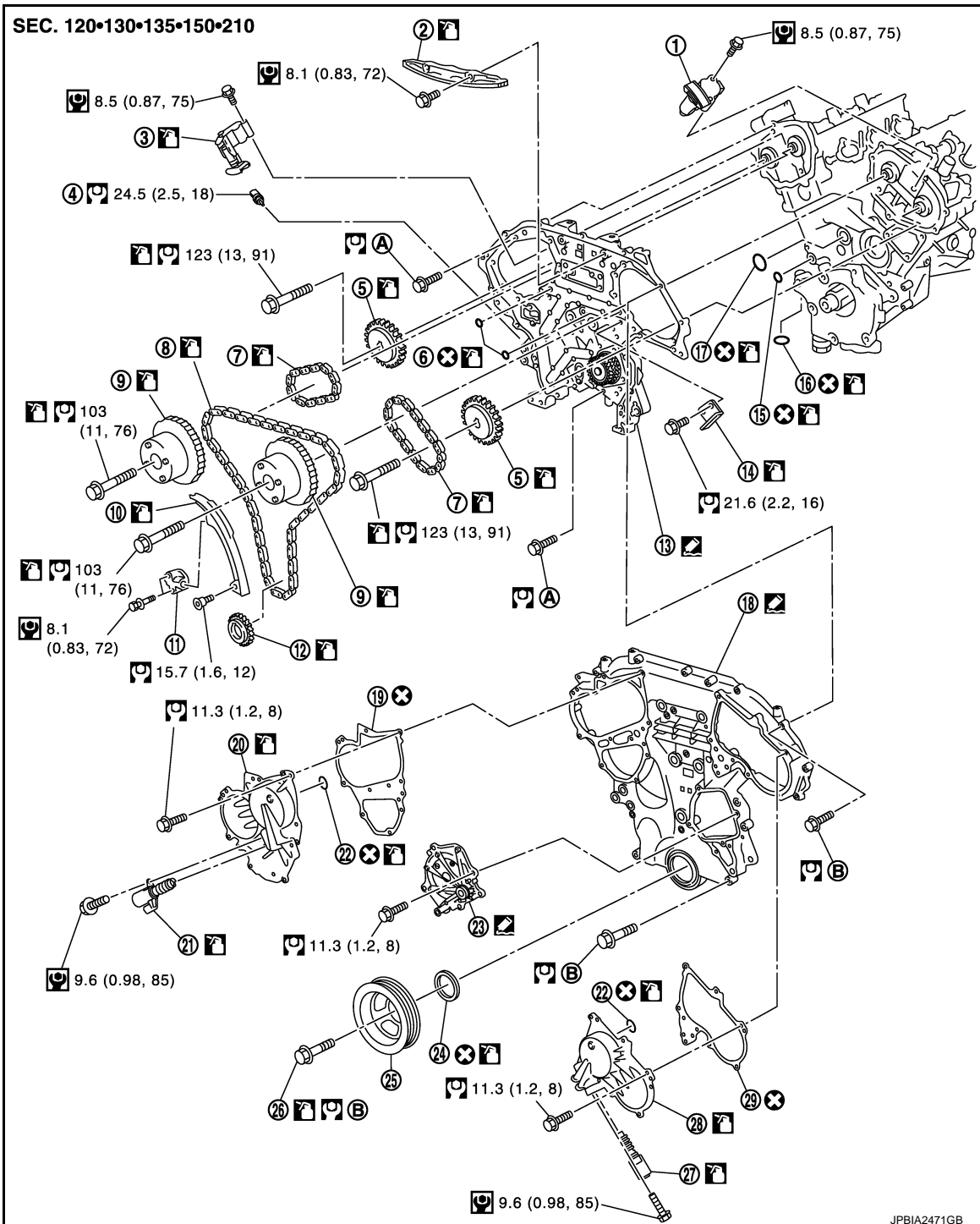

- | | | |
|--|--------------------------------------|--|
| 1. Timing chain tensioner (secondary) (bank 2) | 2. Internal chain guide | 3. Timing chain tensioner (secondary) (bank 1) |
| 4. Oil temperature sensor | 5. Camshaft sprocket (EXH) | 6. O-ring |
| 7. Timing chain (secondary) | 8. Timing chain (primary) | 9. Camshaft sprocket (INT) |
| 10. Slack guide | 11. Timing chain tensioner (primary) | 12. Crankshaft sprocket |
| 13. Rear timing chain case | 14. Tension guide | 15. O-ring |
| 16. O-ring | 17. O-ring | 18. Front timing chain case |

REAR TIMING CHAIN CASE

< UNIT DISASSEMBLY AND ASSEMBLY >

- | | | |
|--|--|---|
| 19. Valve timing control cover gasket (bank 1) | 20. Valve timing control cover (bank 1) | 21. Intake valve timing control solenoid valve (bank 1) |
| 22. Seal ring | 23. Water pump cover | 24. Front oil seal |
| 25. Crankshaft pulley | 26. Crankshaft pulley bolt | 27. Intake valve timing control solenoid valve (bank 2) |
| 28. Valve timing control cover (bank 2) | 29. Valve timing control cover gasket (bank 2) | |
- A. Comply with the assembly procedure when tightening. Refer to [EM-94](#)
- B. Comply with the assembly procedure when tightening. Refer to [EM-58](#)

Refer to [GI-4, "Components"](#) for symbols in the figure.

Disassembly and Assembly

INFOID:000000006260644

DISASSEMBLY

- Remove front timing chain case and timing chain. Refer to [EM-57, "Exploded View"](#).
- Remove water pump. Refer to [CO-21, "Exploded View"](#).
- Remove oil pans (upper and lower) and oil strainer. Refer to [EM-43, "Exploded View"](#).
- Remove rear timing chain case as follows:
 - Loosen and remove mounting bolts in the reverse order as shown in the figure.
 - Cut liquid gasket using the seal cutter [SST: KV10111100 (J-37228)] and remove rear timing chain case.

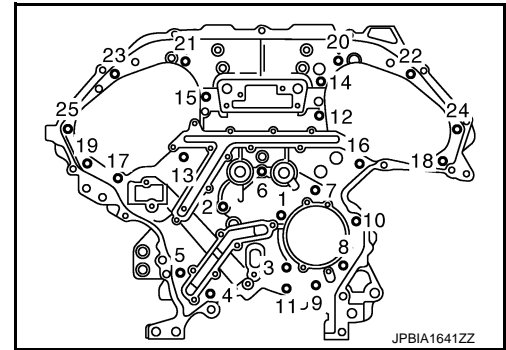

CAUTION:

- Never remove plate metal cover (1) of oil passage.
- After removal, handle rear timing chain case carefully so it does not tilt, cant, or warp under a load.

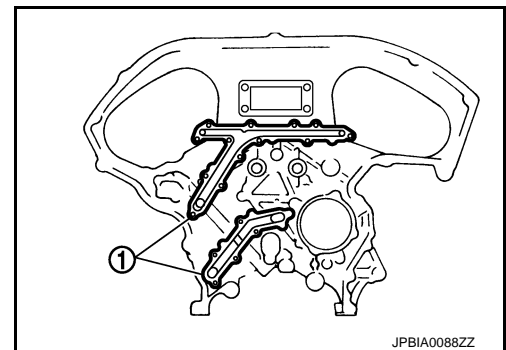

- Remove O-rings (1) from cylinder block.

⇐ : Engine front

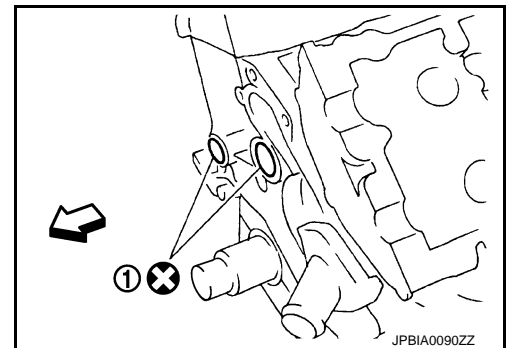

- Remove timing chain tensioners (secondary) from cylinder head as follows, if necessary.

REAR TIMING CHAIN CASE

< UNIT DISASSEMBLY AND ASSEMBLY >

- Remove camshaft brackets (No. 1). Refer to [EM-98. "Exploded View"](#).
- Remove timing chain tensioners (secondary) (1) with a stopper pin (B) attached.

A : Bank 1
B : Bank 2

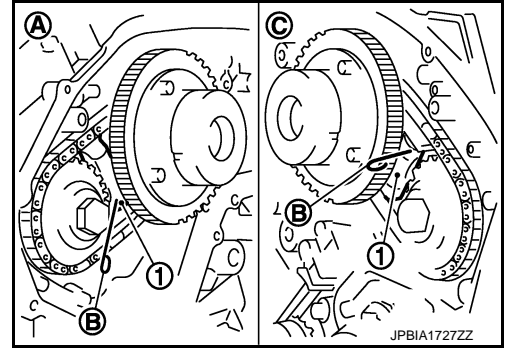

- Use a scraper to remove all traces of old liquid gasket from front and rear timing chain cases, and opposite mating surfaces.
 - Remove old liquid gasket from bolt hole (B) and thread.

A : Remove sticking old liquid gasket

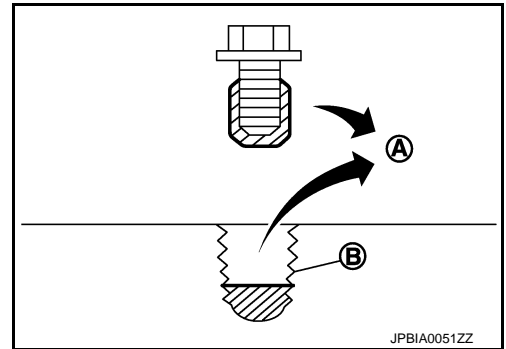

ASSEMBLY

CAUTION:

Do not reuse O-rings.

- Install rear timing chain case as follows:
 - Install new O-rings (1) onto cylinder block.

⇐ : Engine front

CAUTION:

Do not reuse O-rings.

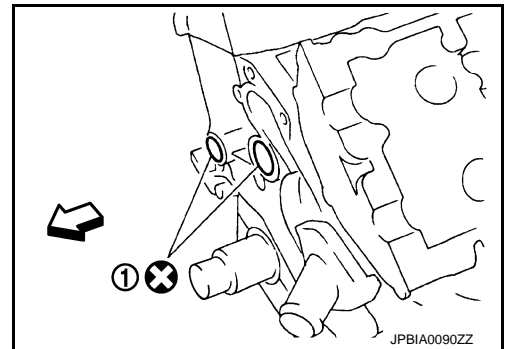

- Apply liquid gasket with the tube presser (commercial service tool) to rear timing chain case back side as shown in the figure.

Use Genuine RTV Silicone Sealant or equivalent. Refer to [GI-22. "Recommended Chemical Products and Sealants"](#).

CAUTION:

- For "A" in the figure, completely wipe out liquid gasket extended on a portion touching at engine coolant.

REAR TIMING CHAIN CASE

< UNIT DISASSEMBLY AND ASSEMBLY >

- Apply liquid gasket on installation position of water pump and cylinder head very completely.

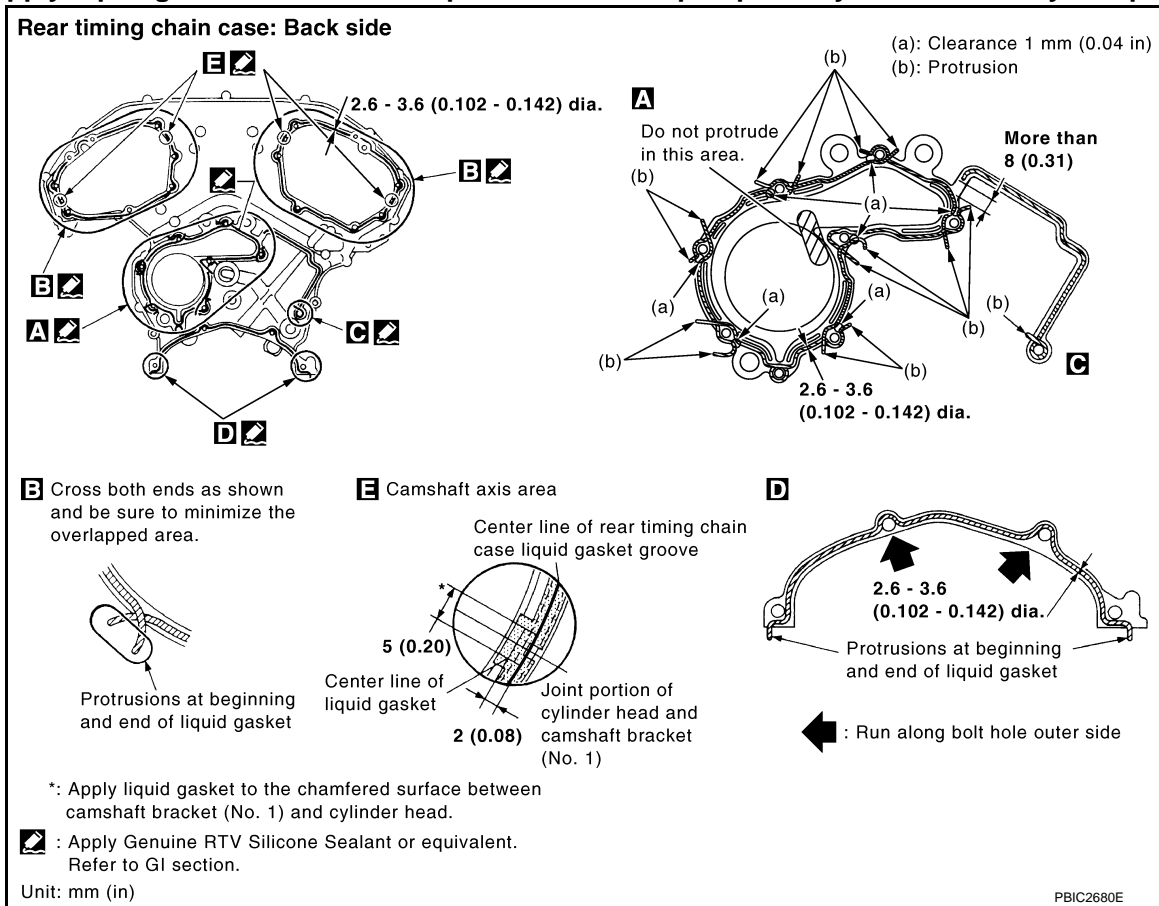

- b. Align rear timing chain case with dowel pins (bank 1 and bank 2) on cylinder block and install rear timing chain case.
- Check O-rings stay in place during installation to cylinder block and cylinder head.
- c. Tighten mounting bolts in numerical order as shown in the figure.
- There are two types of mounting bolts. Refer to the following for locating bolts.

Bolt length:	Bolt position
20 mm (0.79 in)	: 1, 2, 3, 6, 7, 8, 9, 10
16 mm (0.63 in)	: Except the above

: 12.7 N·m (1.3 kg·m, 9 ft·lb)

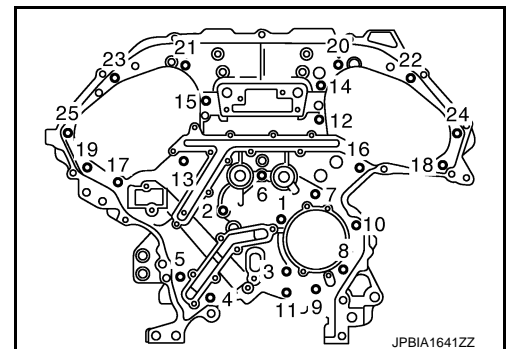

- d. After all bolts tightening, retighten them to the specified in numerical order as shown in the figure.
- If liquid gasket protrudes, wipe it off immediately.
- e. After installing rear timing chain case (1), check the surface height difference between the following parts on the oil pan (upper) mounting surface.

2 : Cylinder block

Standard

Rear timing chain case to cylinder block:

-0.24 to 0.14 mm (-0.009 to 0.006 in)

- If not within the standard, repeat the installation procedure.

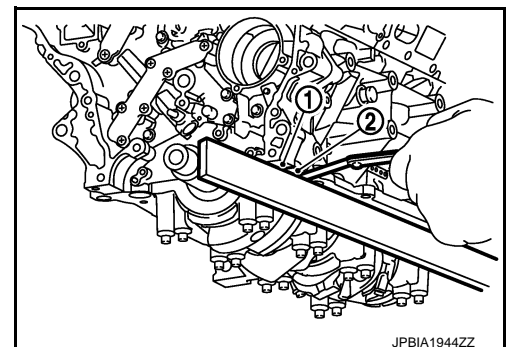

REAR TIMING CHAIN CASE

< UNIT DISASSEMBLY AND ASSEMBLY >

2. Install water pump with new O-rings. Refer to [CO-21. "Exploded View"](#).

CAUTION:

Do not reuse O-rings.

3. Install front timing chain case and timing chain. Refer to [EM-57. "Exploded View"](#).
4. After installing front timing chain case, check the surface height difference between the following parts on the oil pan (upper) mounting surface.

Standard

Front timing chain case to rear timing chain case:

-0.14 to 0.14 mm (-0.006 to 0.006 in)

- If not within the standard, repeat the installation procedure.

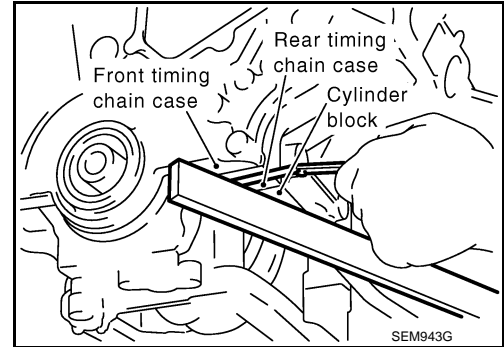

5. Install in the reverse order of removal after this step.

A

EM

C

D

E

F

G

H

I

J

K

L

M

N

O

P

CAMSHAFT

< UNIT DISASSEMBLY AND ASSEMBLY >

CAMSHAFT

Exploded View

INFOID:000000006260645

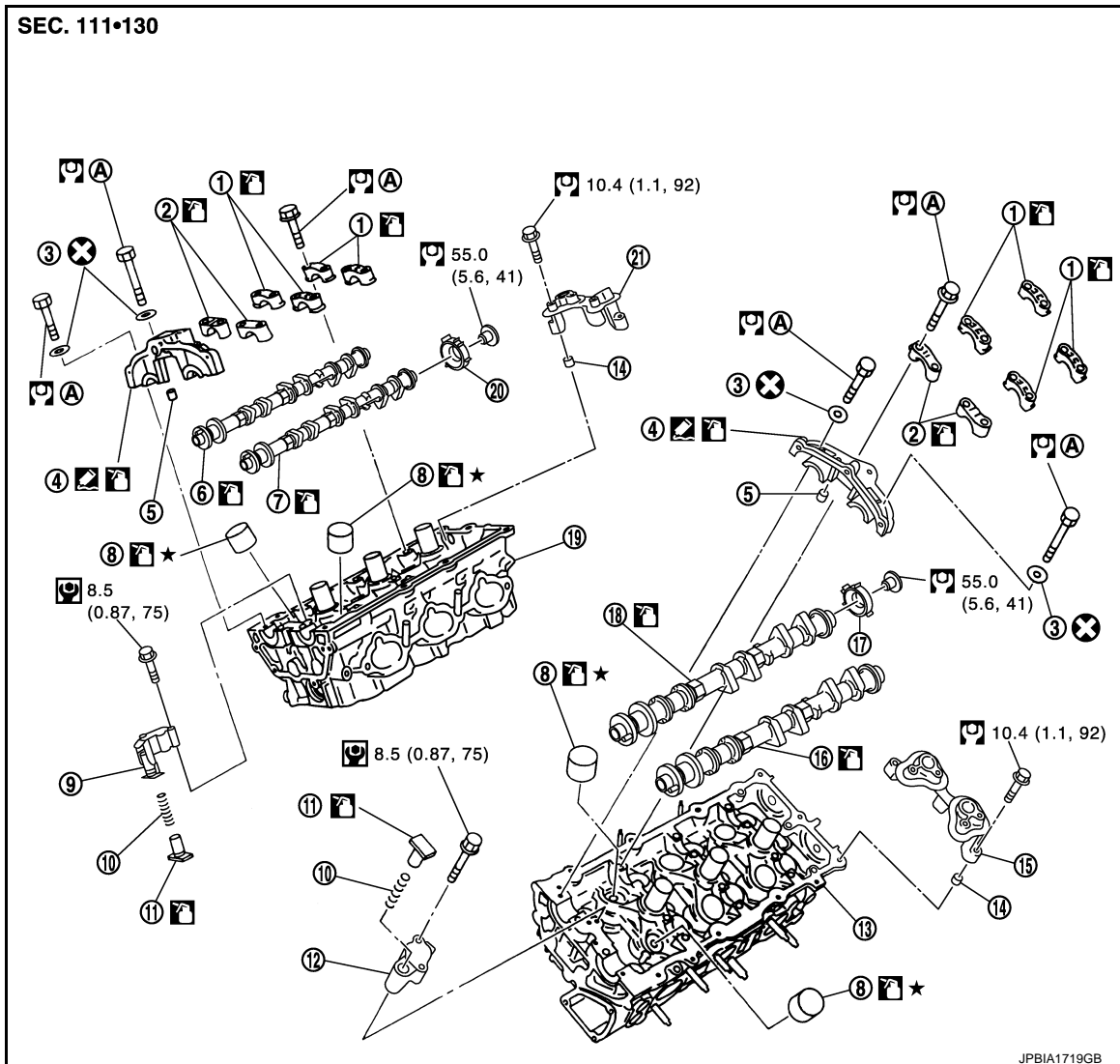

- | | | |
|--------------------------------|------------------------------------|---|
| 1. Camshaft bracket (No. 3, 4) | 2. Camshaft bracket (No. 2) | 3. Seal washer |
| 4. Camshaft bracket (No. 1) | 5. Dowel pin | 6. Camshaft (EXH) (bank 1) |
| 7. Camshaft (INT) (bank 1) | 8. Valve lifter | 9. Timing chain tensioner (secondary) (bank 1) |
| 10. Spring | 11. Plunger | 12. Timing chain tensioner (secondary) (bank 2) |
| 13. Cylinder head (bank 2) | 14. Dowel pin | 15. Camshaft sensor bracket (bank 2) |
| 16. Camshaft (EXH) (bank 2) | 17. Camshaft signal plate (bank 2) | 18. Camshaft (INT) (bank 2) |
| 19. Cylinder head (bank 1) | 20. Camshaft signal plate (bank 1) | 21. Camshaft sensor bracket (bank 1) |

A. Comply with the assembly procedure when tightening. Refer to [EM-98](#)

Refer to [GI-4, "Components"](#) for symbols in the figure.

Removal and Installation

INFOID:000000006260646

REMOVAL

CAMSHAFT

< UNIT DISASSEMBLY AND ASSEMBLY >

1. Remove front timing chain case, camshaft sprocket, timing chain and rear timing chain case. Refer to [EM-57, "Exploded View"](#) and [EM-93, "Exploded View"](#).
2. Loosen camshaft sensor bracket bolts in the reverse order as shown in the figure.

⇐ : Engine front

NOTE:

The order of loosening bolts in the same for bank 1 and bank 2.

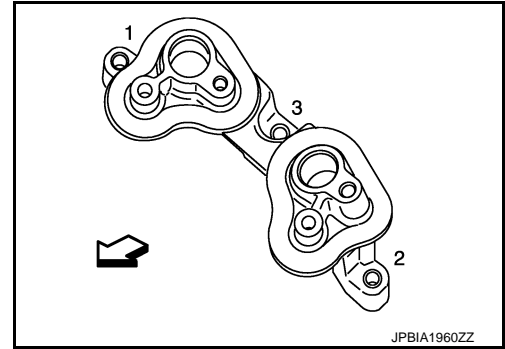

3. Remove camshaft brackets.
 - Mark camshafts, camshaft brackets and bolts so they are placed in the same position and direction for installation.
 - Equally loosen camshaft bracket bolts in several steps in the reverse order as shown in the figure.

⇐ : Engine front

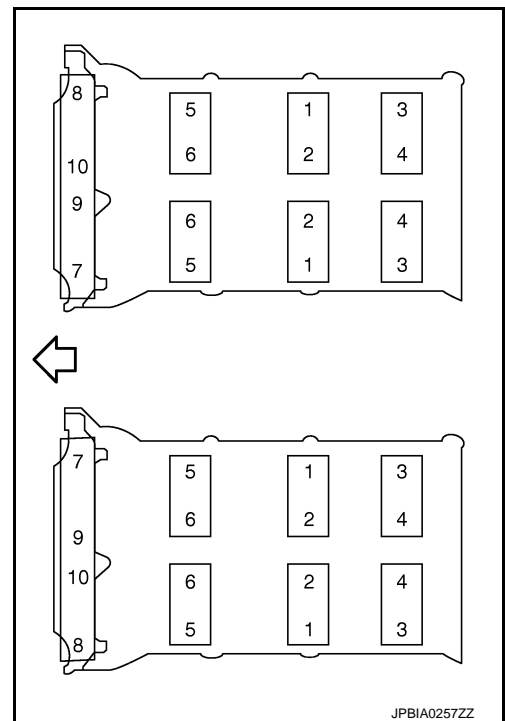

4. Remove camshafts.
5. Remove valve lifters.
 - Identify installation positions, and store them without mixing them up.
6. Remove timing chain tensioners (secondary) (1) from cylinder head.

A : Bank 1

B : Bank 2

- Remove timing chain tensioner (secondary) with its stopper pin (C) attached.

NOTE:

Stopper pin was attached when timing chain (secondary) was removed.

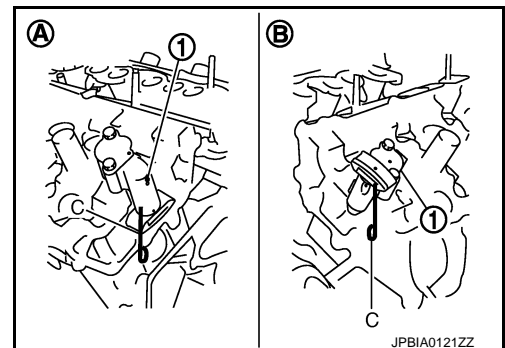

INSTALLATION

CAUTION:

Do not reuse washers.

CAMSHAFT

< UNIT DISASSEMBLY AND ASSEMBLY >

1. Install timing chain tensioners (secondary) (1) on both sides of cylinder head.

A : Bank 1

B : Bank 2

- Install timing chain tensioner (secondary) with its stopper pin (C) attached.
- Install timing chain tensioner (secondary) with sliding part facing downward on cylinder head (bank 1), and with sliding part facing upward on cylinder head (bank 2).

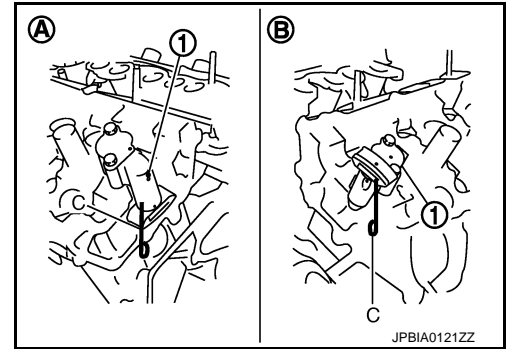

JPBIA0121ZZ

2. Install valve lifters.
 - Install it in the original position.
3. Install camshafts.

⇐ : Engine front

- Follow your identification marks made during removal, or follow the identification marks that are present on new camshafts for proper placement and direction.

Bank	INT/EXH	Dowel pin (1)	Paint marks		
			M1 (D)	M2 (E)	M3 (C)
1	EXH (B)	Yes	No	Light blue	Light blue
	INT (A)	Yes	Pink	No	Light blue
2	INT (A)	Yes	Pink	No	Light blue
	EXH (B)	Yes	No	Light blue	Light blue

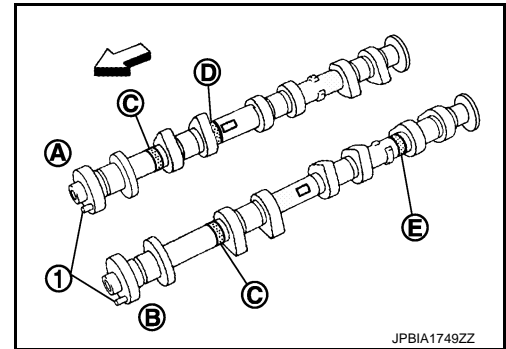

JPBIA1749ZZ

- Install camshaft so dowel pin (A) on front end face are positioned as shown in the figure. (No. 1 cylinder TDC on its compression stroke)

NOTE:

Though camshaft does not stop at the portion as shown in the figure, for the placement of cam nose, it is generally accepted camshaft is placed for the same direction of the figure.

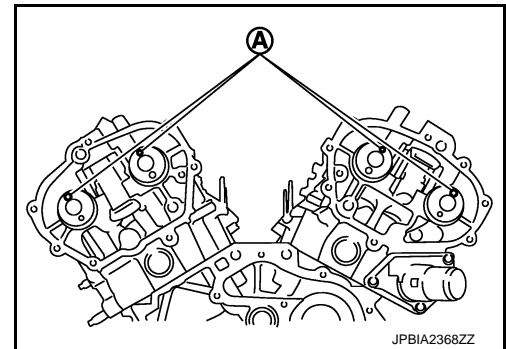

JPBIA2368ZZ

4. Install camshaft brackets.
 - Remove foreign material completely from camshaft bracket backside and from cylinder head installation face.

CAMSHAFT

< UNIT DISASSEMBLY AND ASSEMBLY >

- Install camshaft bracket in original position and direction as shown in the figure.

- A : No. 1
- B : No. 2
- C : No. 3
- D : No. 4
- E : Bank 1
- F : Exhaust side
- G : Intake side
- H : Bank 2
- I : Intake side
- J : Exhaust side
- ← : Engine front

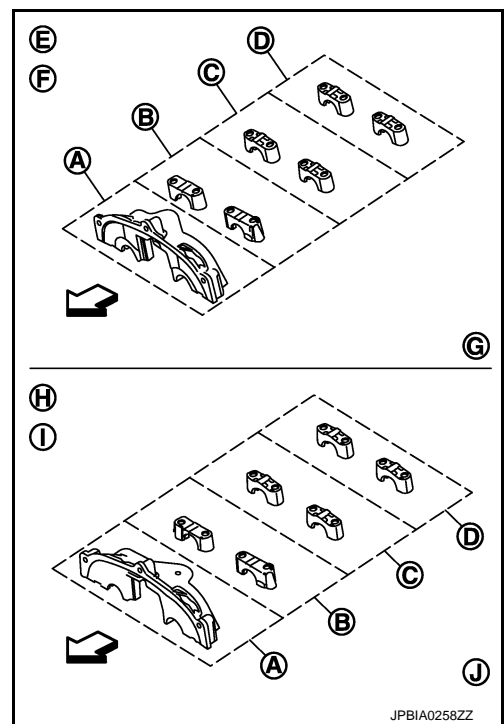

- Install camshaft brackets (No. 2 to 4) aligning the stamp marks (A) as shown in the figure.

- B : Bank 1
- C : Bank 2
- ← : Engine front

NOTE:

There are no identification marks indicating left and right for camshaft bracket (No. 1).

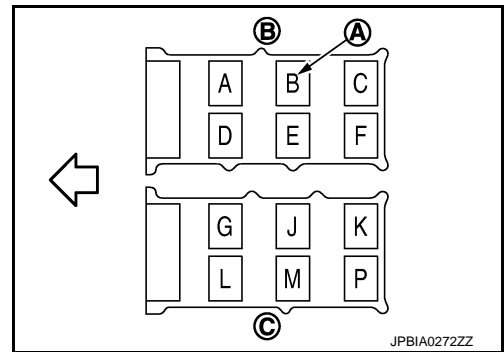

- Apply liquid gasket to mating surface of camshaft bracket (No. 1) as shown on bank 1 and bank 2.

- a : 8.5 mm (0.335 in)
- b : 2 mm (0.08 in)
- c : Clearance 5 mm (0.20 in)
- d : $\phi 2.0 - 2.3$ mm (0.079 - 0.091 in)
- * : Apply liquid gasket to rear timing chain case side

Use Genuine RTV Silicone Sealant or equivalent. Refer to [GI-22. "Recommended Chemical Products and Sealants"](#).

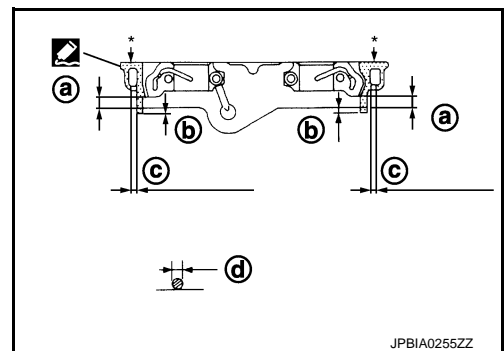

A
EM
C
D
E
F
G
H
I
J
K
L
M
N
O
P

CAMSHAFT

< UNIT DISASSEMBLY AND ASSEMBLY >

5. Tighten camshaft bracket bolts in the following steps, in numerical order as shown in the figure.

← : Engine front

CAUTION:

Do not reuse washers.

- a. Tighten No. 7 to 10 in order as shown.

: **1.96 N·m (0.20 kg-m, 1 ft-lb)**

- b. Tighten No. 1 to 6 in order as shown.

: **1.96 N·m (0.20 kg-m, 1 ft-lb)**

- c. Tighten No. 1 to 10 in numerical order as shown.

: **5.88 N·m (0.60 kg-m, 4 ft-lb)**

- d. Tighten No. 1 to 10 in numerical order as shown.

: **10.4 N·m (1.1 kg-m, 8 ft-lb)**

CAUTION:

After tightening mounting bolts of camshaft brackets (No. 1), be sure to wipe off excessive liquid gasket from the parts list below.

- Mating surface of rocker cover
- Mating surface of rear timing chain case

6. Tighten camshaft sensor bracket bolts in numerical order as shown in the figure.

← : Engine front

NOTE:

The order of tightening bolts in the same for bank 1 and bank 2.

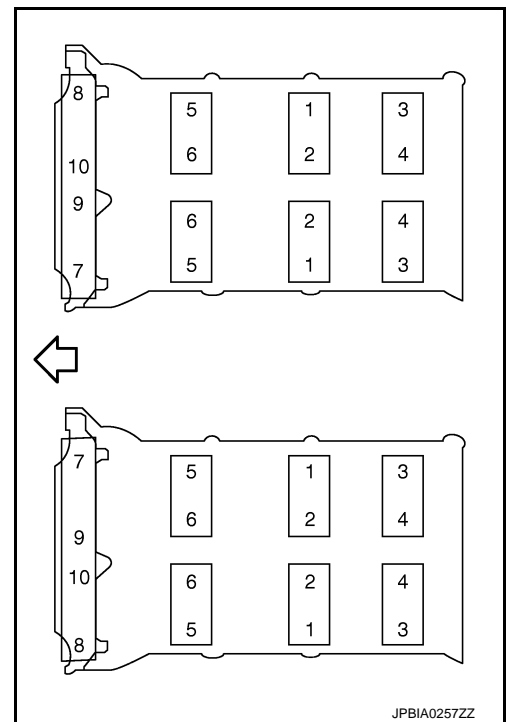

JPBIA0257ZZ

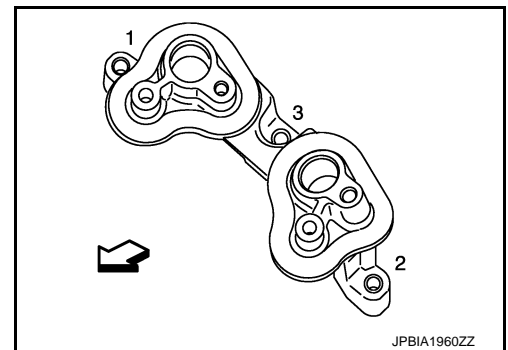

JPBIA1960ZZ

7. Measure difference in levels between front end faces of camshaft bracket (No. 1) and cylinder head.

Standard : -0.14 to 0.14 mm (-0.0055 to 0.0055 in)

- Measure two positions (both intake and exhaust side) for a single bank.
- If the measured value is out of the standard, reinstall camshaft bracket (No. 1).

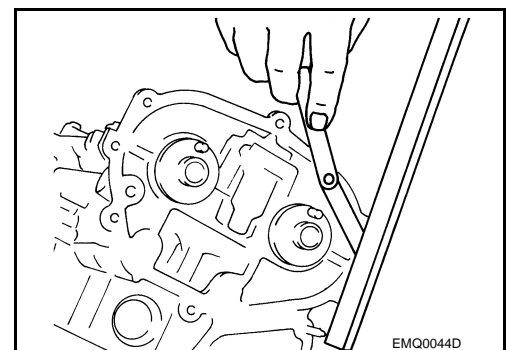

EMQ0044D

8. Inspect and adjust the valve clearance. Refer to [EM-22, "Inspection and Adjustment"](#).

9. Install in the reverse order of removal after this step.

Inspection

INFOID:000000006260647

INSPECTION AFTER REMOVAL

Camshaft Runout

CAMSHAFT

< UNIT DISASSEMBLY AND ASSEMBLY >

1. Put V-block on precise flat table, and support No. 2 and 4 journals of camshaft.

CAUTION:

Never support No. 1 journal (on the side of camshaft sprocket) because it has a different diameter from the other three locations.

2. Set a dial indicator vertically to No. 3 journal.
3. Turn camshaft to one direction with hands, and measure the camshaft runout on a dial indicator. (Total indicator reading)

Standard and limit : Refer to [EM-147, "Camshaft"](#).

4. If it exceeds the limit, replace camshaft.

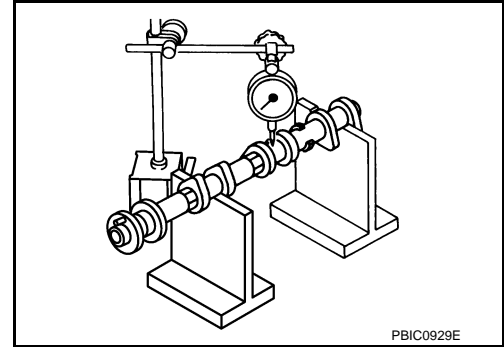

Camshaft Cam Height

1. Measure the camshaft cam height with a micrometer.

Standard cam height (Intake and exhaust) : Refer to [EM-147, "Camshaft"](#).

Cam wear limit : Refer to [EM-147, "Camshaft"](#).

2. If wear exceeds the limit, replace camshaft.

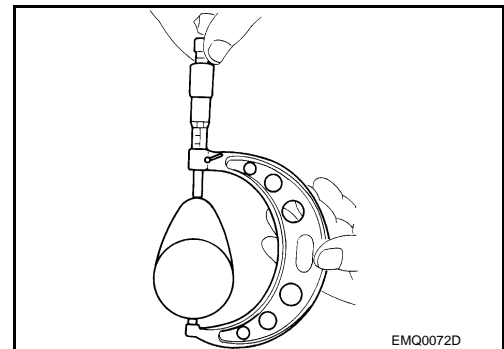

Camshaft Journal Oil Clearance

CAMSHAFT JOURNAL DIAMETER

- Measure the outer diameter of camshaft journal with a micrometer (A).

Standard and limit : Refer to [EM-147, "Camshaft"](#).

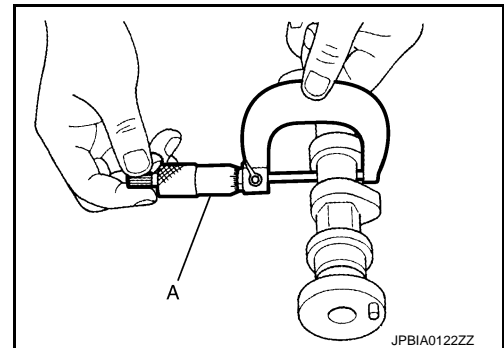

CAMSHAFT BRACKET INNER DIAMETER

- Tighten camshaft bracket bolt with the specified torque. Refer to "INSTALLATION" for the tightening procedure.
- Measure inner diameter (A) of camshaft bracket with a bore gauge.

Standard : Refer to [EM-147, "Camshaft"](#).

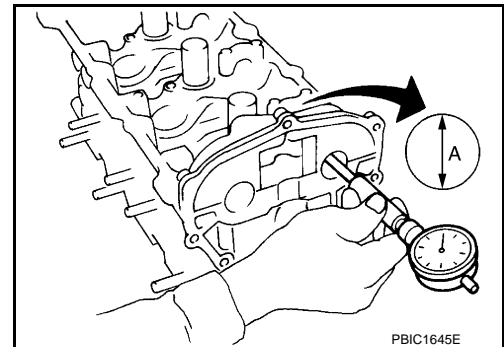

CAMSHAFT JOURNAL OIL CLEARANCE

CAMSHAFT

< UNIT DISASSEMBLY AND ASSEMBLY >

- (Oil clearance) = (Camshaft bracket inner diameter) – (Camshaft journal diameter).

Standard and limit : Refer to [EM-147, "Camshaft"](#).

- If the calculated value exceeds the limit, replace either or both camshaft and cylinder head.

NOTE:

Camshaft brackets cannot be replaced as single parts, because there are machined together with cylinder head. Replace whole cylinder head assembly.

Camshaft End Play

- Install a dial indicator in thrust direction on front end of camshaft. Measure the end play of a dial indicator when camshaft is moved forward/backward (in direction to axis).

Standard and limit : Refer to [EM-147, "Camshaft"](#).

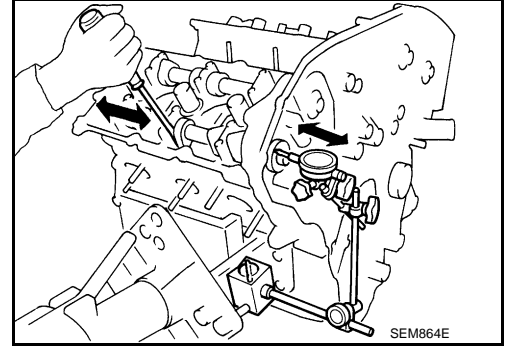

- Measure the following parts if out of the limit.
 - Dimension "A" for camshaft No. 1 journal

Standard : 27.500 - 27.548 mm (1.0827 - 1.0846 in)

- Dimension "B" for cylinder head No. 1 journal bearing

Standard : 27.360 - 27.385 mm (1.0772 - 1.0781 in)

- Refer to the standards above, and then replace camshaft and/or cylinder head.

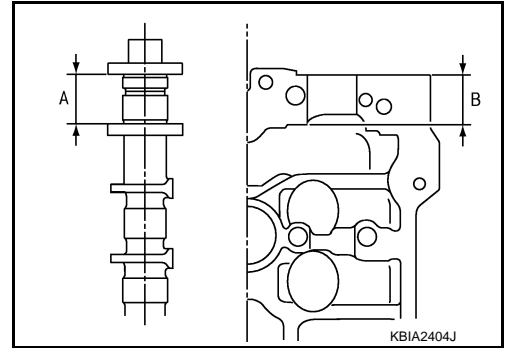

Camshaft Sprocket Runout

1. Put V-block on precise flat table, and support No. 2 and 4 journals of camshaft.

CAUTION:

Never support No. 1 journal (on the side of camshaft sprocket) because it has a different diameter from the other three locations.

2. Measure the camshaft sprocket runout with a dial indicator. (Total indicator reading)

Limit : Refer to [EM-147, "Camshaft"](#).

- If it exceeds the limit, replace camshaft sprocket.

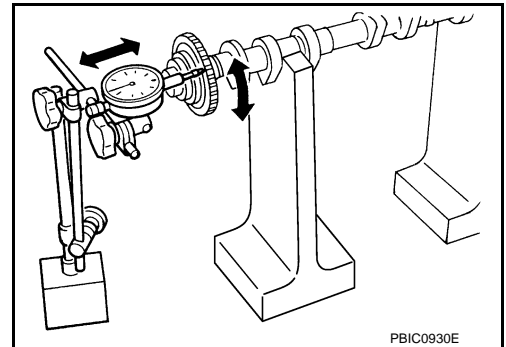

Valve Lifter

CAMSHAFT

< UNIT DISASSEMBLY AND ASSEMBLY >

Check if surface of valve lifter has any wear or cracks.

- If anything above is found, replace valve lifter. Refer to [EM-147, "Camshaft"](#).

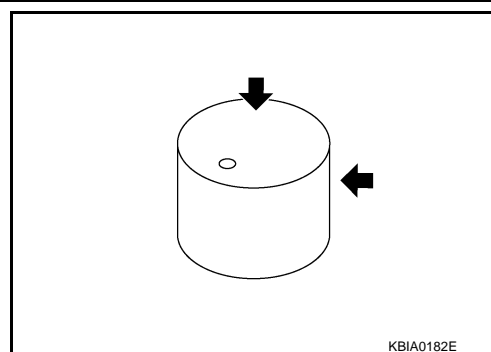

Valve Lifter Clearance

VALVE LIFTER OUTER DIAMETER

- Measure the outer diameter at 1/2 height of valve lifter with a micrometer (A) since valve lifter is in barrel shape.

Standard (Intake and exhaust) : Refer to [EM-147, "Camshaft"](#).

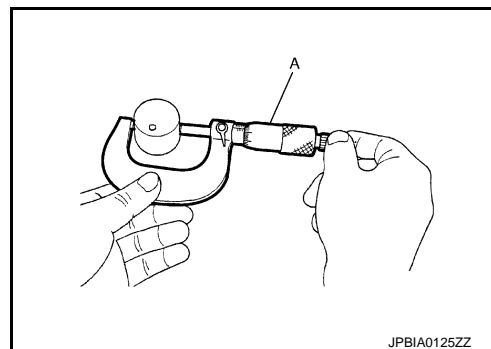

VALVE LIFTER HOLE DIAMETER

- Measure the inner diameter of valve lifter hole of cylinder head with an inside micrometer.

Standard (Intake and exhaust) : Refer to [EM-147, "Camshaft"](#).

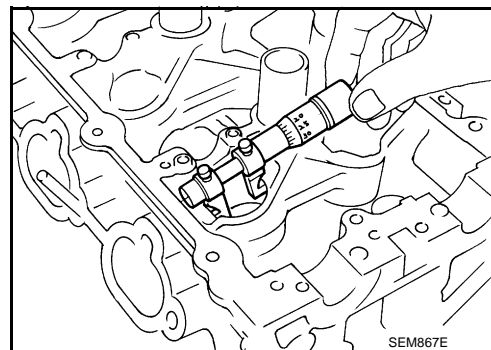

VALVE LIFTER CLEARANCE

- (Valve lifter clearance) = (Valve lifter hole diameter) – (Valve lifter outer diameter)

Standard (Intake and exhaust) : Refer to [EM-147, "Camshaft"](#).

- If the calculated value is out of the standard, referring to each standard of valve lifter outer diameter and valve lifter hole diameter, replace either or both valve lifter and cylinder head.

INSPECTION AFTER INSTALLATION

Inspection of Camshaft Sprocket (INT) Oil Groove

CAUTION:

- Perform this inspection only when DTC P0011 is detected in self-diagnostic results of CONSULT-III and it is directed according to inspection procedure of EC section. Refer to [EC-154, "Diagnosis Procedure"](#).
- Check when engine is cold so as to prevent burns from the splashing engine oil.
 1. Check engine oil level. Refer to [LU-7, "Inspection"](#).
 2. Perform the following procedure so as to prevent the engine from being unintentionally started while checking.
 - a. Release the fuel pressure. Refer to [EC-546, "Inspection"](#).

CAMSHAFT

< UNIT DISASSEMBLY AND ASSEMBLY >

- b. Disconnect ignition coil and injector harness connectors. Refer to [EM-54. "Exploded View"](#) and [EM-49. "Exploded View"](#).
3. Remove intake valve timing control solenoid valve. Refer to [EM-93. "Exploded View"](#).
4. Crank engine, and then check that engine oil comes out from intake valve timing control solenoid valve hole (A). End crank after checking.

1 : Valve timing control cover (bank 2)

⇐ : Engine front

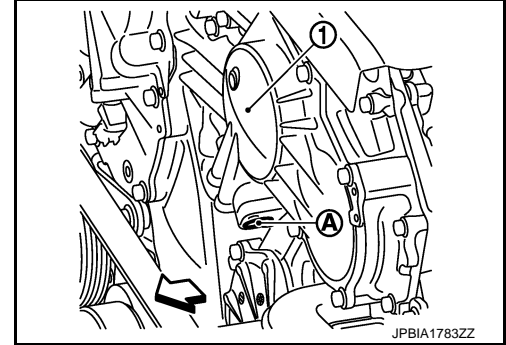

WARNING:

Be careful not to touch rotating parts. (drive belt, idler pulley, and crankshaft pulley, etc.)

CAUTION:

- Prevent splashing by using a shop cloth so as to prevent the worker from injury from engine oil and so as to prevent engine oil contamination.
 - Prevent splashing by using a shop cloth so as to prevent engine oil from being splashed to engine and vehicle. Especially, be careful no to apply engine oil to rubber parts of drive belt, engine mounting insulator, etc. Wipe engine oil off immediately if it is splashed.
5. Perform the following inspection if engine oil does not come out from intake valve timing control solenoid valve oil hole of the cylinder head.
 - Remove oil filter, and then clean it. Refer to [LU-10. "Removal and Installation"](#).
 - Clean oil groove between oil strainer and intake valve timing control solenoid valve. Refer to [LU-2. "Engine Lubrication System"](#).
 6. Remove components between intake valve timing control solenoid valve and camshaft sprocket (INT), and then check each oil groove for clogging.
 - Clean oil groove if necessary. Refer to [LU-2. "Engine Lubrication System"](#).
 7. After inspection, install removed parts in the reverse order.

Inspection for Leakage

The following are procedures for checking fluids leakage and lubricates leakage.

- Before starting engine, check oil/fluid levels including engine coolant and engine oil. If less than required quantity, fill to the specified level. Refer to [MA-15. "FOR NORTH AMERICA : Fluids and Lubricants"](#) (for North America) or [MA-16. "FOR MEXICO : Fluids and Lubricants"](#) (for Mexico).
- Use procedure below to check for fuel leakage.
 - Turn ignition switch "ON" (with engine stopped). With fuel pressure applied to fuel piping, check for fuel leakage at connection points.
 - Start engine. With engine speed increased, check again for fuel leakage at connection points.
- Run engine to check for unusual noise and vibration.

NOTE:

If hydraulic pressure inside timing chain tensioner drops after removal/installation, slack in the guide may generate a pounding noise during and just after engine start. However, this is normal. Noise will stop after hydraulic pressure rises.

- Warm up engine thoroughly to check there is no leakage of fuel, or any oil/fluids including engine oil and engine coolant.
- Bleed air from lines and hoses of applicable lines, such as in cooling system.
- After cooling down engine, again check oil/fluid levels including engine oil and engine coolant. Refill to the specified level, if necessary.

Summary of the inspection items:

Items		Before starting engine	Engine running	After engine stopped
Engine coolant		Level	Leakage	Level
Engine oil		Level	Leakage	Level
Transmission / transaxle fluid	AT & CVT Models	Leakage	Level / Leakage	Leakage
	MT Models	Level / Leakage	Leakage	Level / Leakage
Other oils and fluids*		Level	Leakage	Level
Fuel		Leakage	Leakage	Leakage
Exhaust gases		—	Leakage	—

CAMSHAFT

< UNIT DISASSEMBLY AND ASSEMBLY >

*: Power steering fluid, brake fluid, etc.

A

EM

C

D

E

F

G

H

I

J

K

L

M

N

O

P

OIL SEAL

< UNIT DISASSEMBLY AND ASSEMBLY >

OIL SEAL

VALVE OIL SEAL

VALVE OIL SEAL : Removal and Installation

INFOID:000000006260648

REMOVAL

1. Remove camshaft relating to valve oil seal to be removed. Refer to [EM-98. "Exploded View"](#).
2. Remove valve lifters. Refer to [EM-98. "Exploded View"](#).
3. Turn crankshaft until the cylinder requiring new oil seals is at TDC. This will prevent valve from dropping into cylinder.

4. Remove valve collet.

- Compress valve spring with the valve spring compressor [SST: KV10116200 (J-26336-A)] (A), the attachment [SST: KV10115900 (J-26336-20)] (C), the adapter [SST: KV10109220 (—)] (B). Remove valve collet with a magnet hand.

CAUTION:

When working, take care not to damage valve lifter holes.

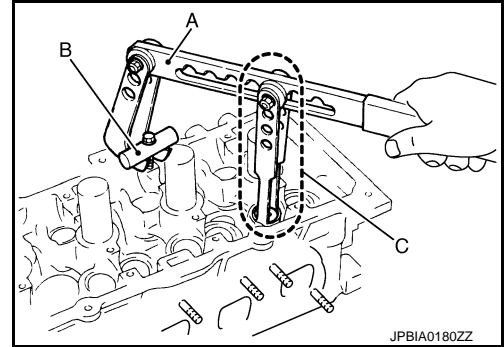

5. Remove valve spring retainer, and valve spring.

6. Remove valve oil seal using the valve oil seal puller [SST: KV10107902 (J-38959)] (A).

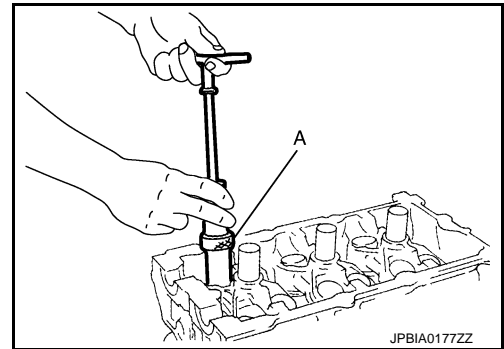

INSTALLATION

1. Apply new engine oil on new valve oil seal joint and seal lip.
2. Using the valve oil seal drift [SST: KV10115600 (J-38958)] (A), press fit valve seal to height (b) shown in the figure.

NOTE:

Dimension: Height measured before valve spring seat installation

Intake and exhaust : 14.3 - 14.9 mm (0.563 - 0.587 in)

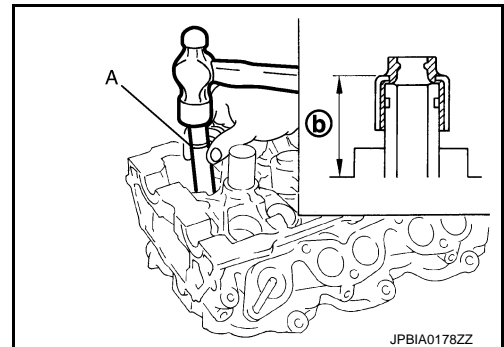

3. Install in the reverse order of removal after this step.

FRONT OIL SEAL

FRONT OIL SEAL : Removal and Installation

INFOID:000000006260649

REMOVAL

OIL SEAL

< UNIT DISASSEMBLY AND ASSEMBLY >

1. Remove the following parts:
 - Road wheel and tire (RH)
 - Splash guard (RH): Refer to [EXT-23, "FENDER PROTECTOR : Exploded View"](#).
 - Drive belt: Refer to [EM-17, "Removal and Installation"](#).
 - Crankshaft pulley: Refer to [EM-57, "Exploded View"](#).

2. Remove front oil seal using a suitable tool.

CAUTION:

Be careful not to damage front timing chain case and crankshaft.

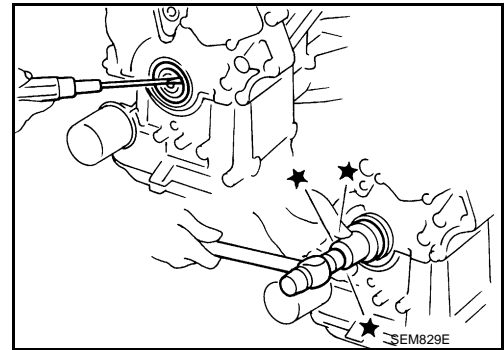

INSTALLATION

1. Apply new engine oil to both oil seal lip and dust seal lip of new front oil seal.
2. Install front oil seal.
 - Install front oil seal so that each seal lip is oriented as shown in the figure.

- A : Oil seal lip
- B : Dust seal lip
- ⇐ : Engine inside
- ➡ : Engine outside

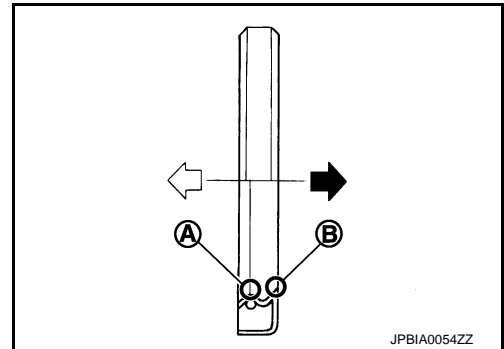

- Using a suitable drift, press-fit until the height of front oil seal is level with the mounting surface.
- Suitable drift: outer diameter 60 mm (2.36 in), inner diameter 50 mm (1.97 in).
- Check the garter spring is in position and seal lips not inverted.

CAUTION:

- **Be careful not to damage front timing chain case and crankshaft.**
- **Press-fit straight and avoid causing burrs or tilting oil seal.**

3. Install in the reverse order of removal after this step.

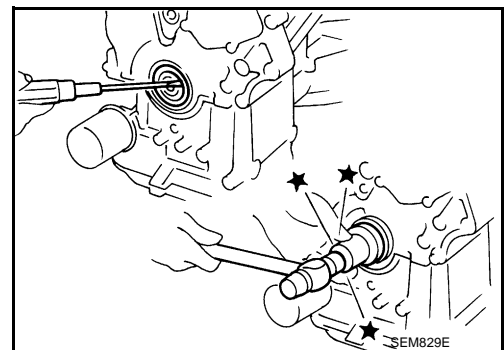

REAR OIL SEAL

REAR OIL SEAL : Removal and Installation

INFOID:000000006260650

REMOVAL

1. Remove transaxle assembly. Refer to [TM-174, "Exploded View"](#).
2. Remove drive plate. Refer to [EM-122, "Exploded View"](#).
3. Remove oil pan (upper). Refer to [EM-43, "Exploded View"](#).

OIL SEAL

< UNIT DISASSEMBLY AND ASSEMBLY >

4. Use a seal cutter (SST) to cut away liquid gasket and remove rear oil seal retainer.

CAUTION:

Be careful not to damage mating surfaces.

NOTE:

Regard both rear oil seal and retainer an assembly.

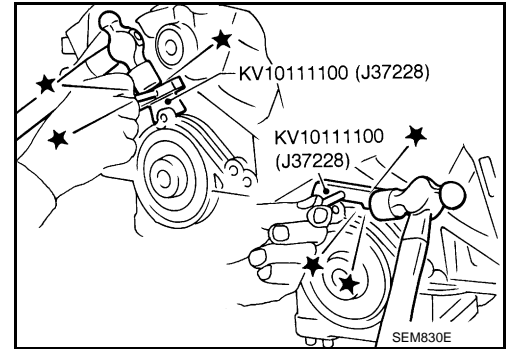

INSTALLATION

1. Remove old liquid gasket on mating surfaces of cylinder block and oil pan (upper) using scraper.
2. Apply new engine oil to both oil seal lip and dust seal lip of new oil seal retainer.
3. Apply a continuous bead of liquid gasket with the tube presser (commercial service tool) to rear oil seal retainer as shown in the figure.

a : $\phi 2.0 - 3.0$ mm (0.08 - 0.12 in)

Use Genuine RTV Silicone Sealant or equivalent. Refer to [GI-22, "Recommended Chemical Products and Sealants"](#).

CAUTION:

Attaching should be done within 5 minutes after coating.

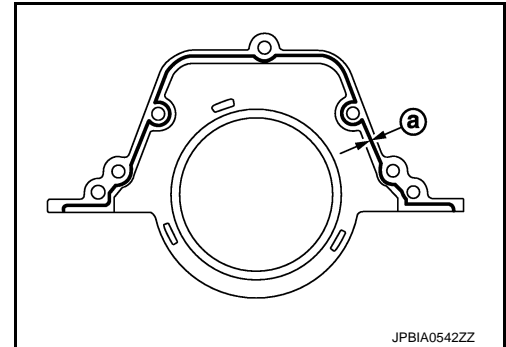

4. Install rear oil seal retainer to cylinder block. Refer to [EM-122, "Exploded View"](#).
 - Check the garter spring is in position and seal lips not inverted.
5. Install in the reverse order of removal after this step.

CYLINDER HEAD

< UNIT DISASSEMBLY AND ASSEMBLY >

CYLINDER HEAD

Exploded View

INFOID:000000006260651

REMOVAL

A

EM

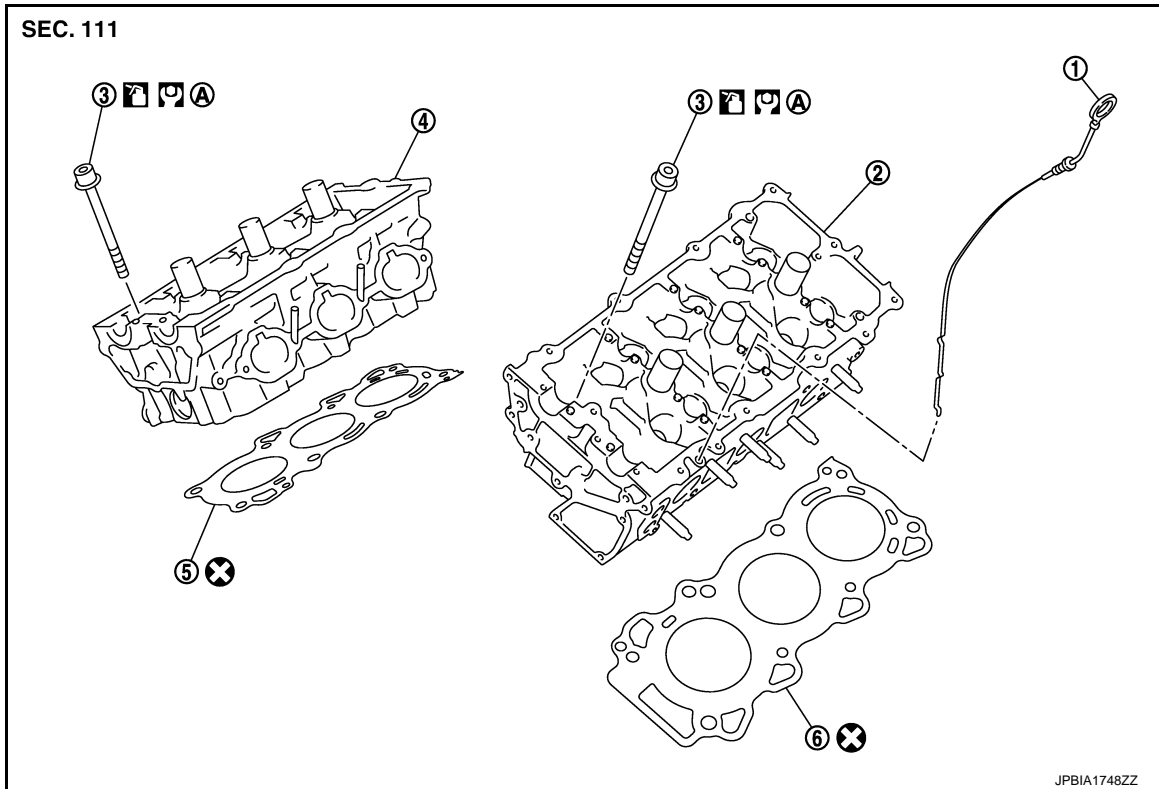

- | | | |
|--|----------------------------------|----------------------------------|
| 1. Oil level gauge | 2. Cylinder head (bank 2) | 3. Cylinder head bolt |
| 4. Cylinder head (bank 1) | 5. Cylinder head gasket (bank 1) | 6. Cylinder head gasket (bank 2) |
| A. Comply with the assembly procedure when tightening. Refer to EM-112 | | |

Refer to [GI-4, "Components"](#) for symbols in the figure.

DISASSEMBLY

C

D

E

F

G

H

I

J

K

L

M

N

O

P

CYLINDER HEAD

< UNIT DISASSEMBLY AND ASSEMBLY >

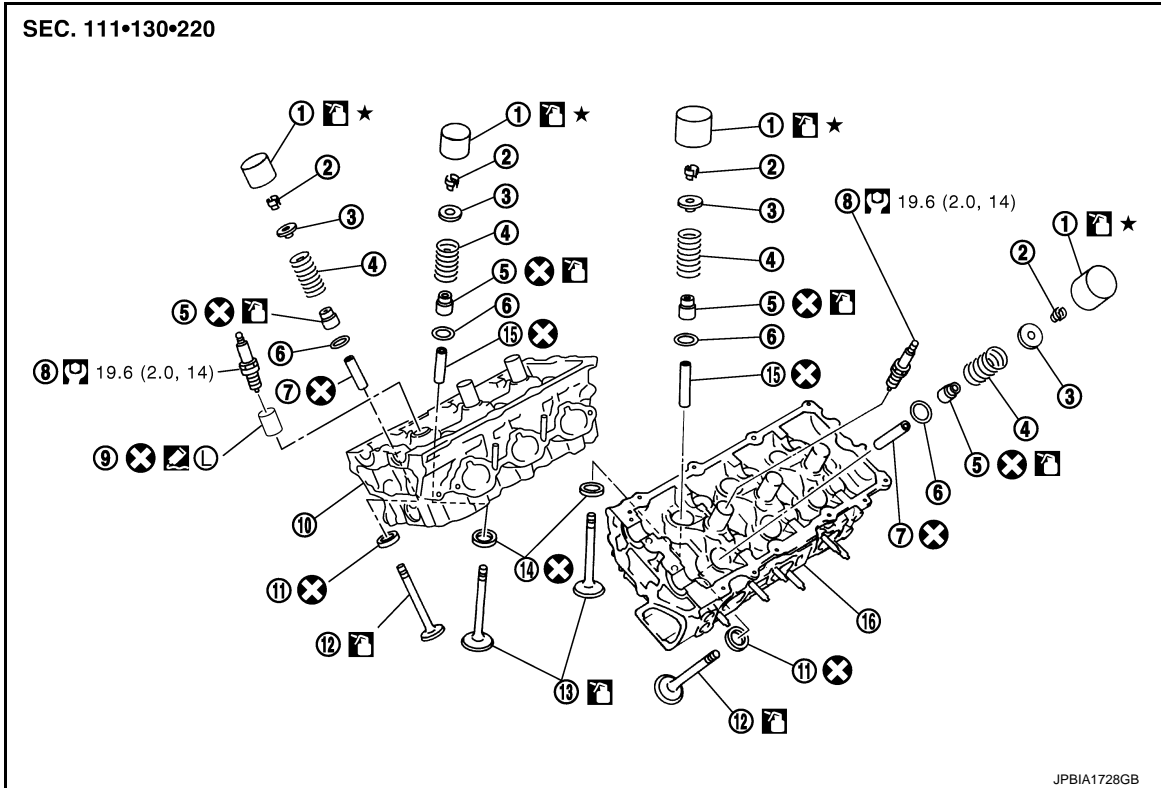

- | | | |
|----------------------------|----------------------|--------------------------|
| 1. Valve lifter | 2. Valve collet | 3. Valve spring retainer |
| 4. Valve spring | 5. Valve oil seal | 6. Valve spring seat |
| 7. Valve guide (EXH) | 8. Spark plug | 9. Spark plug tube |
| 10. Cylinder head (bank 1) | 11. Valve seat (EXH) | 12. Valve (EXH) |
| 13. Valve (INT) | 14. Valve seat (INT) | 15. Valve guide (INT) |
| 16. Cylinder head (bank 2) | | |

: Apply genuine high strength thread locking sealant or equivalent.

Refer to [GI-4, "Components"](#) for symbols not described on the above.

Removal and Installation

INFOID:000000006260652

REMOVAL

- Remove the following parts:
 - Oil level gauge
 - Intake manifold collector: Refer to [EM-33, "Exploded View"](#).
 - Rocker cover: Refer to [EM-54, "Exploded View"](#).
 - Fuel tube and fuel injector assembly: Refer to [EM-49, "Exploded View"](#).
 - Intake manifold: Refer to [EM-36, "Exploded View"](#).
 - Exhaust manifold: Refer to [EM-38, "Exploded View"](#).
 - Water inlet and thermostat assembly: Refer to [CO-26, "Exploded View"](#).
 - Water outlet, water connector, water bypass pipe, and heater pipe: Refer to [CO-28, "Exploded View"](#).
 - Timing chain and rear timing chain case: Refer to [EM-57, "Exploded View"](#) and [EM-93, "Exploded View"](#).
 - Camshaft: Refer to [EM-98, "Exploded View"](#).

CYLINDER HEAD

< UNIT DISASSEMBLY AND ASSEMBLY >

- Remove cylinder head bolts in the reverse order as shown in the figure with cylinder head bolt wrench (commercial service tool) and power tool to remove cylinder heads (bank 1 and bank 2).

- A : Bank 1
 B : Bank 2
 ← : Engine front

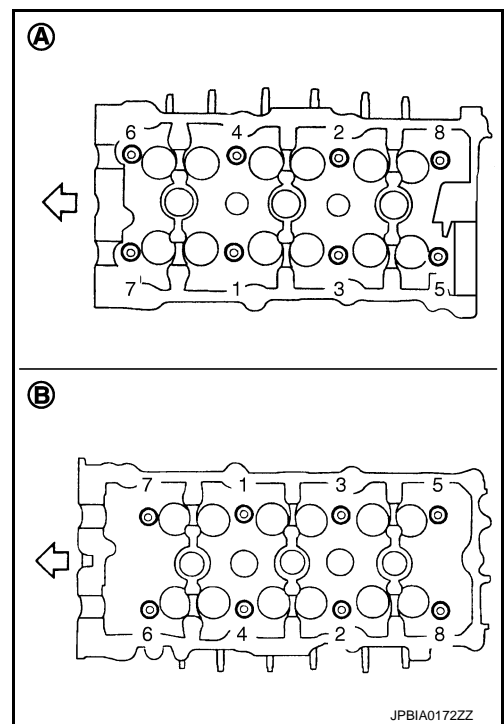

- Remove cylinder head gaskets.

INSTALLATION

- Install new cylinder head gaskets.
- Turn crankshaft until No. 1 piston is set at TDC.
 - Crankshaft key (1) should line up with the bank 1 cylinder center line as shown in the figure.

- ← : Bank 1 side

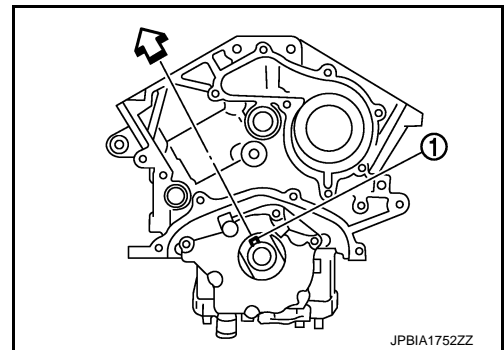

A
 EM
 C
 D
 E
 F
 G
 H
 I
 J
 K
 L
 M
 N
 O
 P

CYLINDER HEAD

< UNIT DISASSEMBLY AND ASSEMBLY >

3. Install cylinder head follow the steps below to tighten cylinder head bolts in numerical order as shown in the figure with cylinder head bolts wrench (commercial service tool).

- A : Bank 1
 B : Bank 2
 : Engine front

CAUTION:

- If cylinder head bolts reused, check their outer diameters before installation. Refer to [EM-119, "Inspection"](#).
- Before installing cylinder head, inspect cylinder head distortion. Refer to [EM-119, "Inspection"](#).

- a. Apply new engine oil to threads and seat surfaces of cylinder head bolts.
 b. Tighten all cylinder head bolts.

: 98.1 N·m (10 kg-m, 72 ft-lb)

- c. Completely loosen all cylinder head bolts.

: 0 N·m (0 kg-m, 0 ft-lb)

CAUTION:

In step "c", loosen bolts in the reverse order of that indicated in the figure.

- d. Tighten all cylinder head bolts.

: 39.2 N·m (4.0 kg-m, 29 ft-lb)

- e. Turn all cylinder head bolts 103 degrees clockwise (angle tightening).

CAUTION:

Check the tightening angle by using the angle wrench [SST: KV10112100 (BT8653-A)] (A). Avoid judgment by visual inspection without.

- Check tightening angle indicated on the angle wrench indicator plate.

- f. Turn all cylinder head bolts 103 degrees clockwise again (angle tightening).

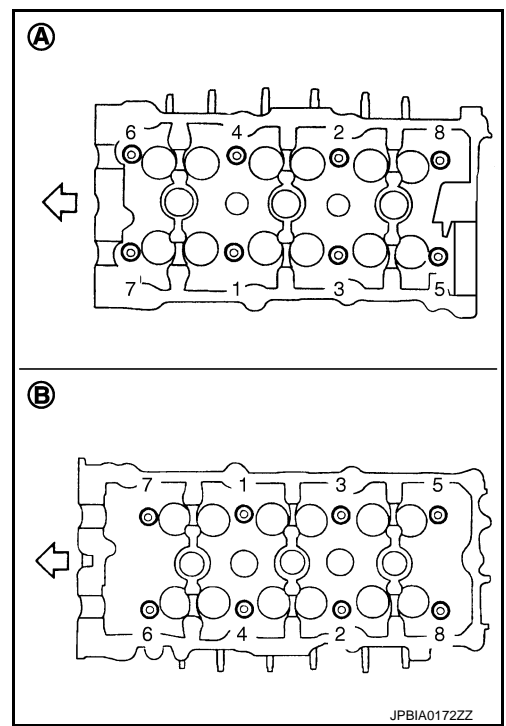

JPBIA0172ZZ

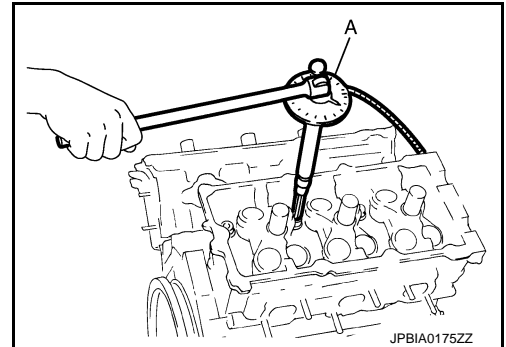

JPBIA0175ZZ

4. After installing cylinder head, measure distance between front end faces of cylinder block and cylinder head (bank 1 and bank 2).

Standard : 14.1 - 14.9 mm (0.555 - 0.587 in)

- If measured value is out of the standard, reinstall cylinder head.

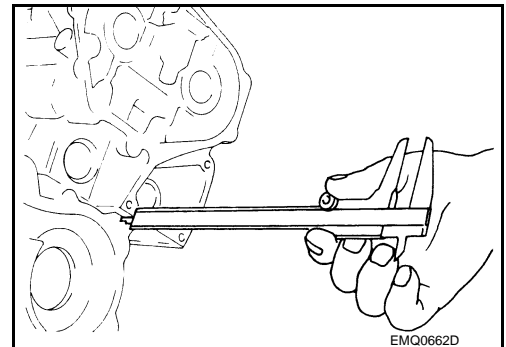

EMQ0662D

5. Install in the reverse order of removal after this step.

CYLINDER HEAD

< UNIT DISASSEMBLY AND ASSEMBLY >

Disassembly and Assembly

INFOID:000000006260653

DISASSEMBLY

1. Remove spark plug with spark plug wrench (commercial service tool).
2. Remove valve lifter.
 - Identify installation positions, and store them without mixing them up.
3. Remove valve collet.
 - Compress valve spring with the valve spring compressor [SST: KV10116200 (J-26336-A)] (A), the attachment [SST: KV10115900 (J-26336-20)] (C) and the adapter [SST: KV10109220 (—)] (B). Remove valve collet with a magnet hand.

CAUTION:

When working, take care not to damage valve lifter holes.

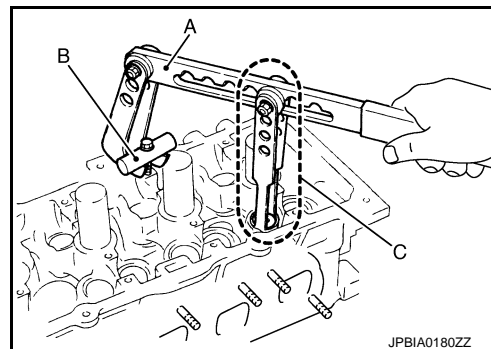

4. Remove valve spring retainer, valve spring and valve spring seat.
5. Push valve stem to combustion chamber side, and remove valve.
 - Identify installation positions, and store them without mixing them up.
6. Remove valve oil seal with the valve oil seal puller [SST: KV10107902 (J-38959)] (A).

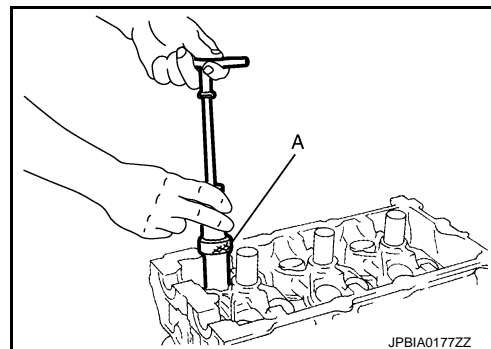

7. Remove valve seat, if valve seat must be replaced.
 - Bore out old seat until it collapses. Boring should not continue beyond the bottom face of the seat recess in cylinder head. Set the machine depth stop to ensure this. Refer to [EM-149, "Cylinder Head"](#).

CAUTION:

Prevent to scratch cylinder head by excessive boring.

8. Remove valve guide, if valve guide must be replaced.
 - a. To remove valve guide, heat cylinder head to 110 to 130°C (230 to 266°F) by soaking in heated oil (A).

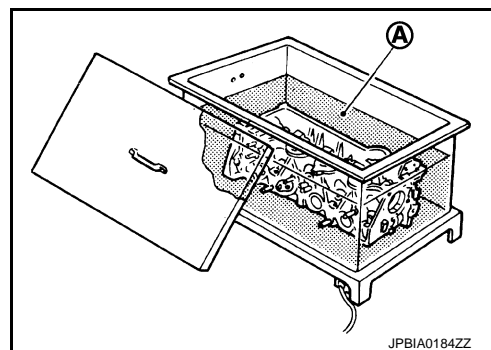

CYLINDER HEAD

< UNIT DISASSEMBLY AND ASSEMBLY >

- b. Drive out valve guide with a press [under a 20 kN (2 ton, 2.2 US ton, 2.0 Imp ton) pressure] or a hammer and the valve guide drift (commercial service tool).

WARNING:

Cylinder head contains heat. When working, wear protective equipment to avoid getting burned.

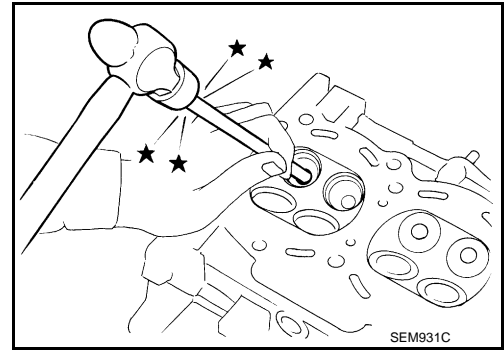

9. Remove spark plug tube if necessary.
- Using a pliers, pull spark plug tube out of cylinder head.

CAUTION:

- Take care not to damage cylinder head.
- Once removed, spark plug tube will be deformed and cannot be reused. Never remove it unless absolutely necessary.

ASSEMBLY

1. If valve guide is removed in step 8 (DISASSEMBLY), install it.
- Replace with oversized [0.2 mm (0.008 in)] valve guide.
- a. Using the valve guide reamer (commercial service tool) (A), ream cylinder head valve guide hole.

Valve guide hole diameter (for service parts):

Intake and exhaust

: Refer to [EM-149, "Cylinder Head"](#).

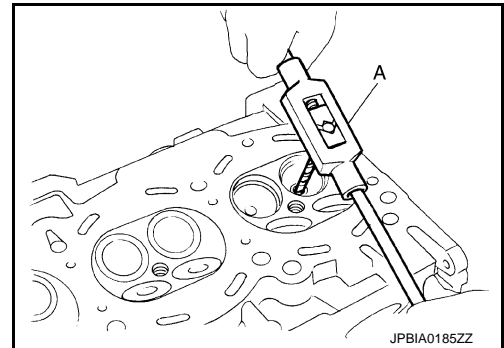

- b. Heat cylinder head to 110 to 130°C (230 to 266°F) by soaking in heated oil (A).

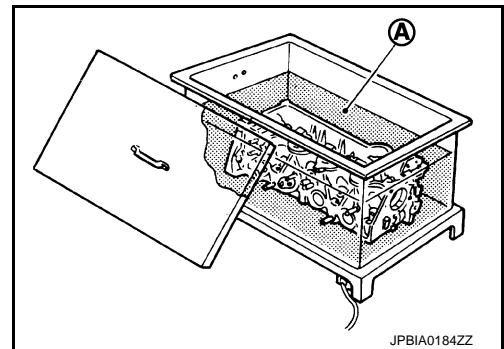

- c. Using the valve guide drift (commercial service tool), press valve guide from camshaft side to the dimensions as in the figure.

Projection (A)

Intake and exhaust

: Refer to [EM-149, "Cylinder Head"](#).

WARNING:

Cylinder head contains heat. When working, wear protective equipment to avoid getting burned.

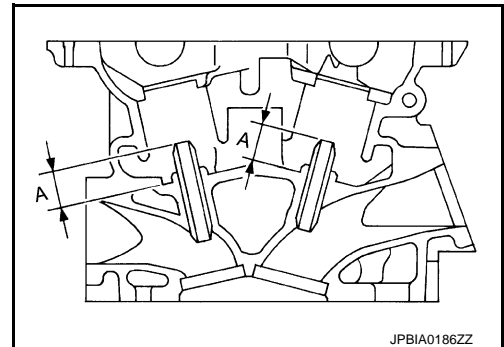

CYLINDER HEAD

< UNIT DISASSEMBLY AND ASSEMBLY >

- d. Using the valve guide reamer (commercial service tool) (A), apply reamer finish to valve guide.

Standard : Refer to [EM-149](#).
(Intake and exhaust) "[Cylinder Head](#)".

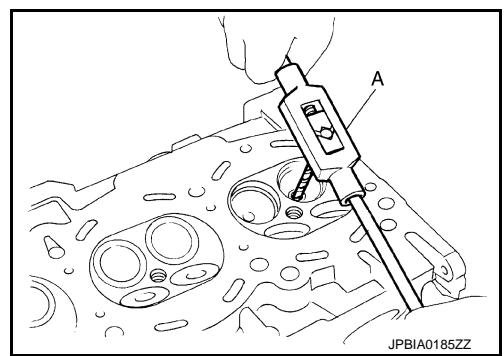

2. If valve seat is removed in step 7 (DISASSEMBLY), install it. Replace with oversize [0.5 mm (0.020 in)] valve seat.
- a. Ream cylinder head recess diameter (a) for service valve seat.

Oversize : Refer to [EM-149](#).
(Intake and exhaust) "[Cylinder Head](#)".

- Be sure to ream in circles concentric to valve guide center. This will enable valve to fit correctly.

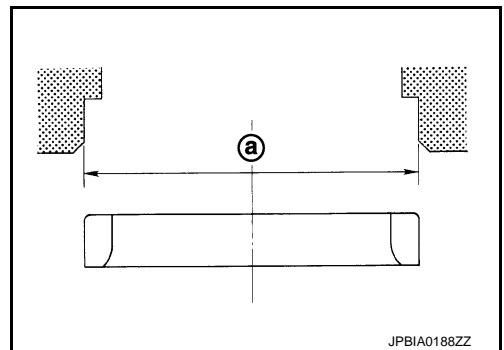

- b. Heat cylinder head to 110 to 130°C (230 to 266°F) by soaking in heated oil (A).

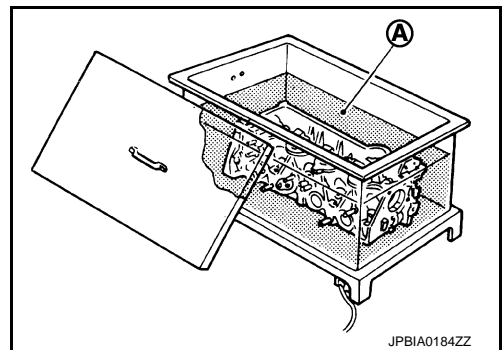

- c. Provide valve seats cooled well with dry ice. Force fit valve seat into cylinder head.

WARNING:

Cylinder head contains heat. When working, wear protective equipment to avoid getting burned.

CAUTION:

Avoid directly touching cold valve seats.

- d. Using the valve seat cutter set (commercial service tool) or valve seat grinder, finish seat to the specified dimensions. Refer to [EM-149](#), "[Cylinder Head](#)".

CAUTION:

When using the valve seat cutter, firmly grip cutter handle with both hands. Then, press on the contacting surface all around the circumference to cut in a single drive. Improper pressure on with cutter or cutting many different times may result in stage valve seat.

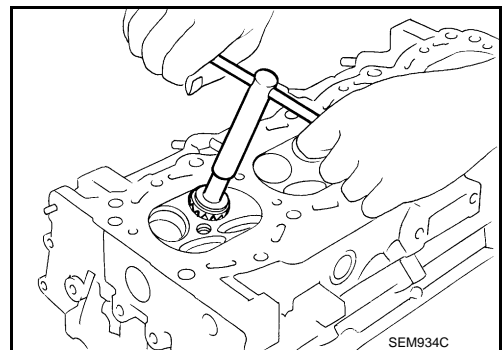

- e. Using compound, grind to adjust valve fitting.
- f. Check again for normal contact. Refer to [EM-119](#), "[Inspection](#)".
3. Install new valve oil seals as follows:

CYLINDER HEAD

< UNIT DISASSEMBLY AND ASSEMBLY >

- a. Apply new engine oil on valve oil seal joint and seal lip.
- b. Install with the valve oil seal drift [SST: KV10115600 (J-38958)] (A) press fit valve seal to height (b) shown in the figure.

NOTE:

Dimension: Height measured before valve spring seat installation.

Intake and exhaust : 14.3 - 14.9 mm (0.563 - 0.587 in)

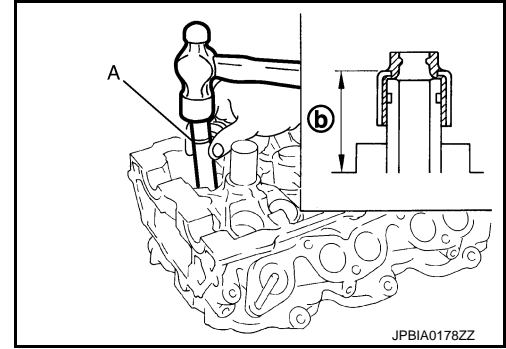

4. Install valve spring seat.
5. Install valve.
 - Install it in the original position.

NOTE:

Larger diameter valves are for intake side.

6. Install valve spring (uneven pitch type).
 - Install narrow pitch end (paint mark) to cylinder head side (valve spring seat side).

- A : Wide pitch
- B : Narrow pitch
- C : Paint mark
- ⇐ : Cylinder head side

Paint mark color: Blue

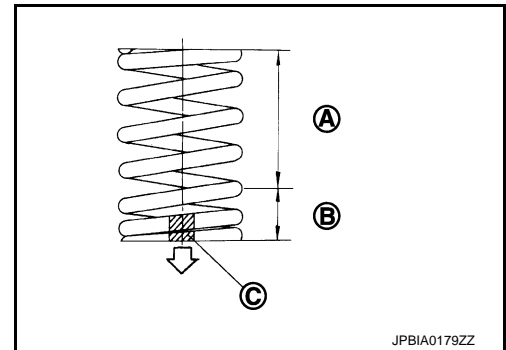

7. Install valve spring retainer.
8. Install valve collet.
 - Compress valve spring with the valve spring compressor [SST: KV10116200 (J-26336-A)] (A), the attachment [SST: KV10115900 (J-26336-20)] (C) and the adapter [SST: KV10109220 (—)] (B). Install valve collet with a magnet hand.

CAUTION:

When working, take care not to damage valve lifter holes.

- Tap valve stem edge lightly with plastic hammer after installation to check its installed condition.

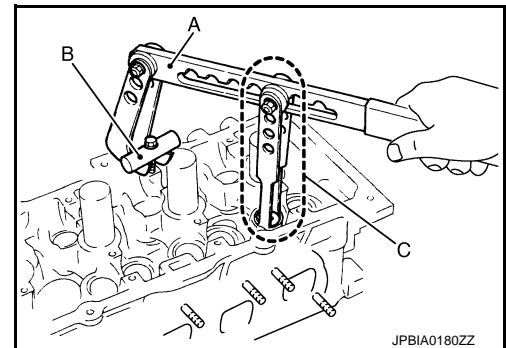

9. Install valve lifter.
 - Install it in the original position.
10. Install spark plug tube.
 - Press-fit spark plug tube as follows:
 - a. Remove old liquid gasket adhering to cylinder head mounting hole.
 - b. Apply sealant to area within approximately 12 mm (0.47 in) from edge of spark plug tube press-fit side.
Use genuine high strength thread locking sealant or equivalent. Refer to [GI-22. "Recommended Chemical Products and Sealants"](#).

CYLINDER HEAD

< UNIT DISASSEMBLY AND ASSEMBLY >

- c. Using a drift, press-fit spark plug tube so that its height (A) is as specified in the figure.

B : Genuine high strength thread locking sealant application area

Standard press-fit height: 37.7 - 38.7 mm (1.484 - 1.524 in)

CAUTION:

- When press-fitting, take care not to deform spark plug tube.
- After press-fitting, wipe off liquid gasket protruding onto cylinder-head upper face.

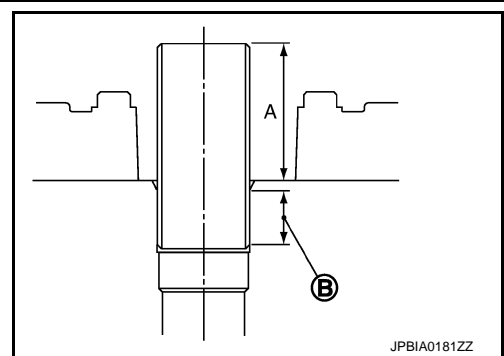

11. Install spark plug with the spark plug wrench (commercial service tool).

Inspection

INFOID:000000006260654

INSPECTION AFTER REMOVAL

Cylinder Head Bolts Outer Diameter

- Cylinder head bolts are tightened by plastic zone tightening method. Whenever the size difference between (C) and (B) exceeds the limit, replace them with new one.

A : Measuring point

d : 11 mm (0.43 in)

e : 48 mm (1.89 in)

Limit [(C) - (B)] : 0.11 mm (0.0043 in)

- If reduction of outer diameter appears in a position other than (B), use it as (B) point.

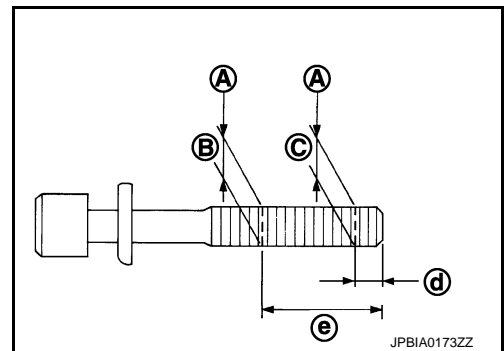

Cylinder Head Distortion

NOTE:

When performing this inspection, cylinder block distortion should be also checking. Refer to [EM-131. "Inspection"](#).

1. Using a scraper, wipe off oil, scale, gasket, sealant and carbon deposits from surface of cylinder head.

CAUTION:

Never allow gasket fragments to enter engine oil or engine coolant passages.

2. At each of several locations on bottom surface of cylinder head, measure the distortion in six directions (A), (B), (C), (D), (E), and (F).

Limit : Refer to [EM-149. "Cylinder Head"](#).

- If it exceeds the limit, replace cylinder head.

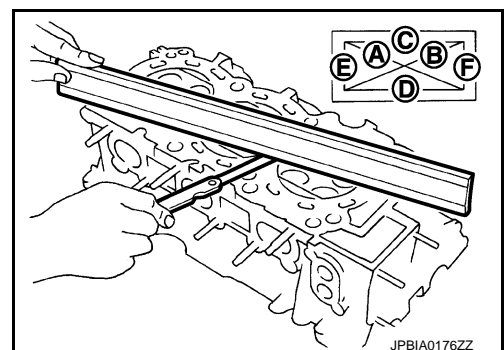

INSPECTION AFTER DISASSEMBLY

Valve Dimensions

- Check the dimensions of each valve. For the dimensions, refer to [EM-149. "Cylinder Head"](#).
- If dimensions are out of the standard, replace valve and check valve seat contact. Refer to "Valve Seat Contact".

Valve Guide Clearance

Valve Stem Diameter

CYLINDER HEAD

< UNIT DISASSEMBLY AND ASSEMBLY >

- Measure the diameter of valve stem with micrometer (A).

Standard (Intake and exhaust) : Refer to [EM-149, "Cylinder Head"](#).

Valve Guide Inner Diameter

- Measure the inner diameter of valve guide with bore gauge.

Standard (Intake and exhaust) : Refer to [EM-149, "Cylinder Head"](#).

Valve Guide Clearance

- (Valve guide clearance) = (Valve guide inner diameter) – (Valve stem diameter)

Valve guide clearance Standard and limit (Intake and exhaust) : Refer to [EM-149, "Cylinder Head"](#).

- If the calculated value exceeds the limit, replace valve and/or valve guide. When valve guide must be replaced, refer to [EM-115, "Disassembly and Assembly"](#).

Valve Seat Contact

- After confirming that the dimensions of valve guides and valves are within the specifications, perform this procedure.
- Apply prussian blue (or white lead) onto contacting surface of valve seat to check the condition of the valve contact on the surface.
- Check if the contact area band is continuous all around the circumference.
- If not, grind to adjust valve fitting and check again. If the contacting surface still has "NG" conditions (B) even after the recheck, replace valve seat. Refer to [EM-115, "Disassembly and Assembly"](#).

A : OK

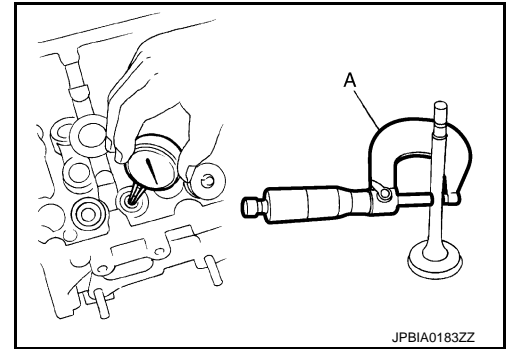

Valve Spring Squareness

- Set a try square (A) along the side of valve spring and rotate spring. Measure the maximum clearance between the top of spring and try square.

B : Contact

Limit : Refer to [EM-149, "Cylinder Head"](#).

- If it exceeds the limit, replace valve spring.

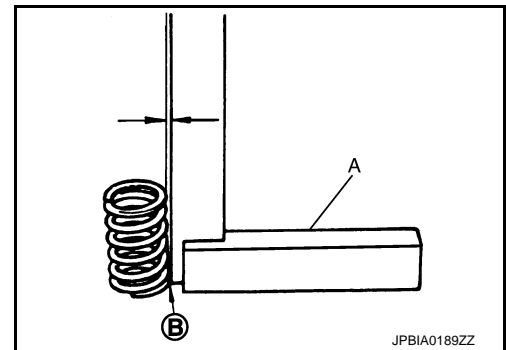
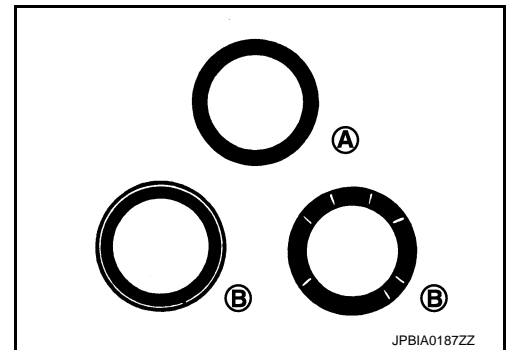

Valve Spring Dimensions and Valve Spring Pressure Load

CYLINDER HEAD

< UNIT DISASSEMBLY AND ASSEMBLY >

- Check the valve spring pressure at specified spring height.

Standard (Intake and exhaust)

Free height

Installation height

Installation load

Height during valve open

Load with valve open

: Refer to [EM-149](#),
"[Cylinder Head](#)".

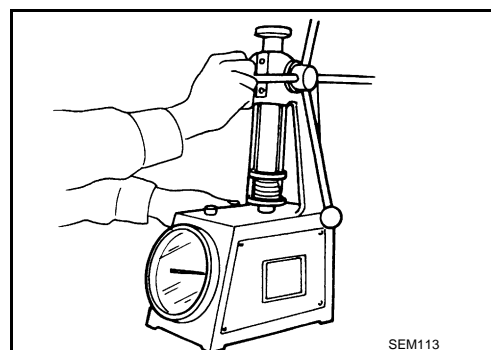

- If the installation load or load with valve open is out of the standard, replace valve spring.

INSPECTION AFTER INSTALLATION

Inspection for Leakage

The following are procedures for checking fluids leakage, lubricates leakage, and exhaust gases leakage.

- Before starting engine, check oil/fluid levels including engine coolant and engine oil. If less than required quantity, fill to the specified level. Refer to [MA-15, "FOR NORTH AMERICA : Fluids and Lubricants"](#) (for North America) or [MA-16, "FOR MEXICO : Fluids and Lubricants"](#) (for Mexico).
- Use procedure below to check for fuel leakage.
 - Turn ignition switch "ON" (with engine stopped). With fuel pressure applied to fuel piping, check for fuel leakage at connection points.
 - Start engine. With engine speed increased, check again for fuel leakage at connection points.
- Run engine to check for unusual noise and vibration.
- Warm up engine thoroughly to check there is no leakage of fuel, exhaust gases, or any oil/fluids including engine oil and engine coolant.
- Bleed air from lines and hoses of applicable lines, such as in cooling system.
- After cooling down engine, again check oil/fluid levels including engine oil and engine coolant. Refill to the specified level, if necessary.

Summary of the inspection items:

Items		Before starting engine	Engine running	After engine stopped
Engine coolant		Level	Leakage	Level
Engine oil		Level	Leakage	Level
Transmission / transaxle fluid	AT & CVT Models	Leakage	Level / Leakage	Leakage
	MT Models	Level / Leakage	Leakage	Level / Leakage
Other oils and fluids*		Level	Leakage	Level
Fuel		Leakage	Leakage	Leakage
Exhaust gases		—	Leakage	—

*: Power steering fluid, brake fluid, etc.

CYLINDER BLOCK

< UNIT DISASSEMBLY AND ASSEMBLY >

CYLINDER BLOCK

Exploded View

INFOID:00000006260655

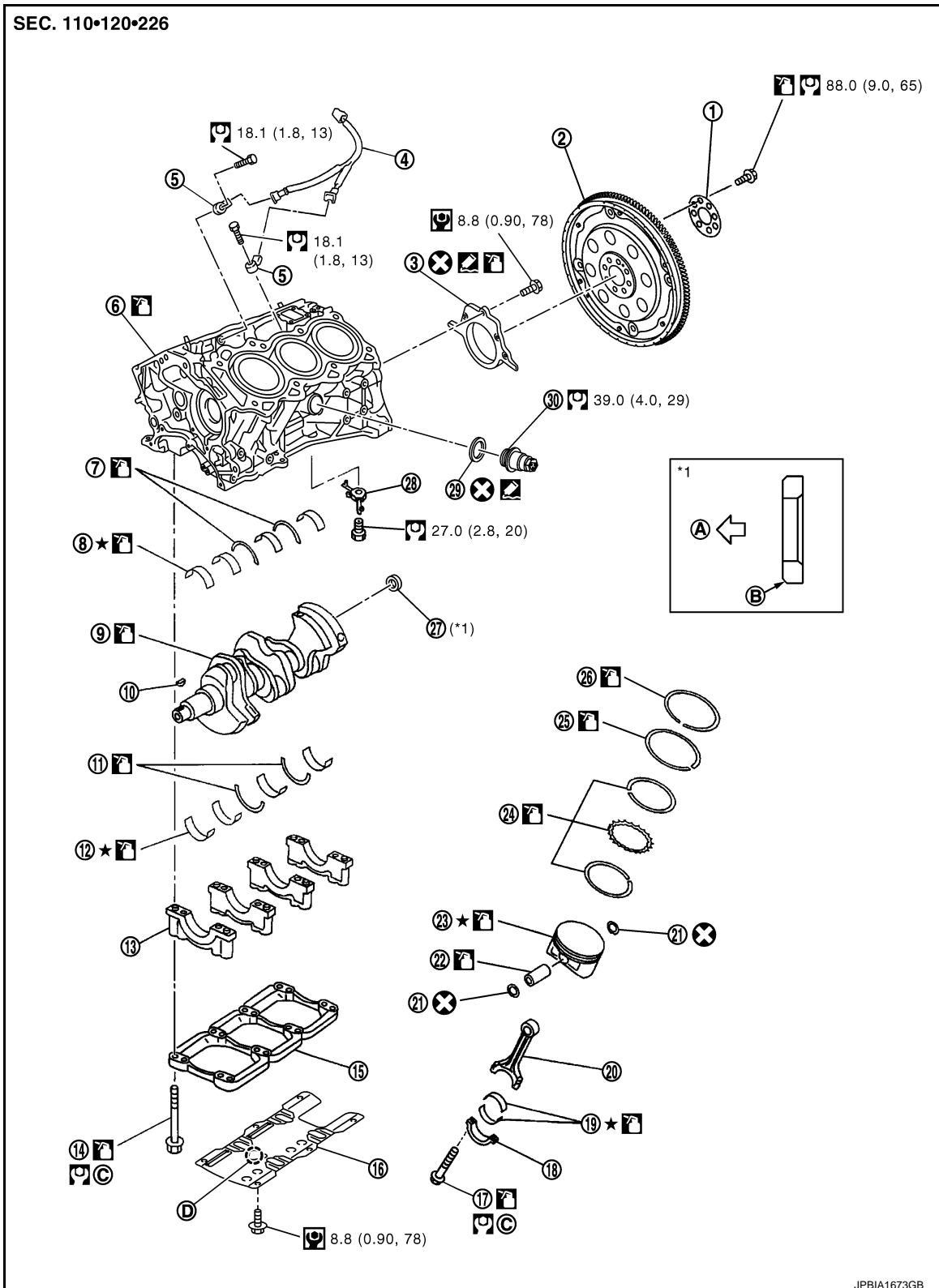

- 1. Reinforcement plate
- 4. Sub harness
- 7. Thrust bearing (upper)

- 2. Drive plate
- 5. Knock sensor
- 8. Main bearing (upper)

- 3. Rear oil seal retainer
- 6. Cylinder block
- 9. Crankshaft

CYLINDER BLOCK

< UNIT DISASSEMBLY AND ASSEMBLY >

- | | | |
|----------------------------|----------------------------|--|
| 10. Crankshaft key | 11. Thrust bearing (lower) | 12. Main bearing (lower) |
| 13. Main bearing cap | 14. Main bearing cap bolt | 15. Main bearing beam |
| 16. Baffle plate | 17. Connecting rod bolt | 18. Connecting rod bearing cap |
| 19. Connecting rod bearing | 20. Connecting rod | 21. Snap ring |
| 22. Piston pin | 23. Piston | 24. Oil ring |
| 25. Second ring | 26. Top ring | 27. Pilot converter |
| 28. Oil jet | 29. Gasket (for Canada) | 30. Cylinder block heater (for Canada) |
| A. Crankshaft side | B. Chamfered | C. Comply with the assembly procedure when tightening. Refer to EM-123 |
| D. Front mark | | |

Refer to [GI-4, "Components"](#) for symbols in the figure.

Disassembly and Assembly

INFOID:000000006260656

DISASSEMBLY

- Remove the following parts:
 - Intake manifold collector: Refer to [EM-33, "Exploded View"](#).
 - Intake manifold: Refer to [EM-36, "Exploded View"](#).
 - Oil pans (lower and upper): Refer to [EM-43, "Exploded View"](#).
 - Front and rear timing chain case: Refer to [EM-93, "Exploded View"](#).
 - Cylinder head: Refer to [EM-111, "Exploded View"](#).
- Remove knock sensor.
CAUTION:
Carefully handle sensor avoiding shocks.
- Remove rear oil seal retainer.
 - Remove by inserting screwdriver between main bearing cap and rear oil seal retainer.
 - CAUTION:**
If rear oil seal retainer is removed, replace it with new one.
 - NOTE:**
Regard both rear oil seal and retainer as an assembly.
- Remove baffle plate from main bearing beam.
- Remove piston and connecting rod assembly with the following procedure:
 - Before removing piston and connecting rod assembly, check the connecting rod side clearance. Refer to [EM-131, "Inspection"](#).
 - CAUTION:**
Be careful not to drop connecting rod bearing, and to scratch the surface.
 - Position crankshaft pin corresponding to connecting rod to be removed onto the bottom dead center.
 - Remove connecting rod bearing cap.
 - Using a hammer handle or similar tool, push piston and connecting rod assembly out to the cylinder head side.
CAUTION:
Be careful not to damage the cylinder wall and crankshaft pin, resulting from an interference of the connecting rod big end.
- Remove connecting rod bearings from connecting rod and connecting rod bearing cap.
CAUTION:
 - Be careful not to drop connecting rod bearing, and to scratch the surface.**
 - Identify installation positions, and store them without mixing them up.**
- Remove piston rings from piston.
 - Before removing piston rings, check the piston ring side clearance. Refer to [EM-131, "Inspection"](#).

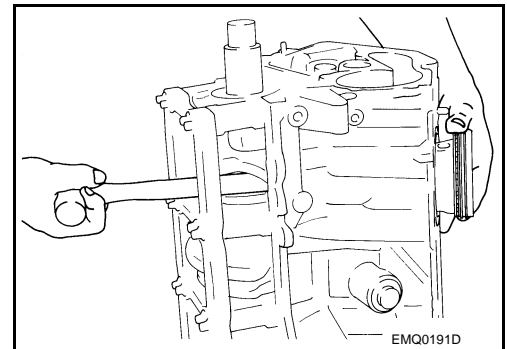

CYLINDER BLOCK

< UNIT DISASSEMBLY AND ASSEMBLY >

- Use a piston ring expander (commercial service tool) (A).

CAUTION:

- When removing piston rings, be careful not to damage piston.
- Be careful not to damage piston rings by expanding them excessively.

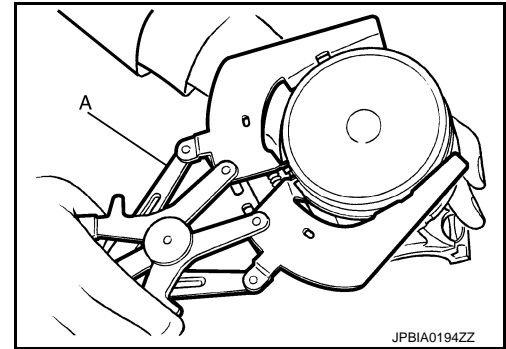

8. Remove piston from connecting rod as follows:

- a. Using a snap ring pliers (A), remove snap rings.

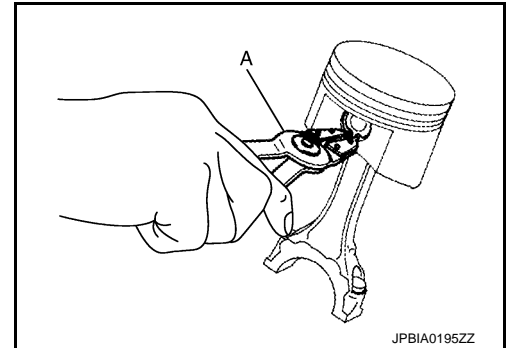

- b. Heat piston to 60 to 70°C (140 to 158°F) with an industrial use drier (A) or equivalent.

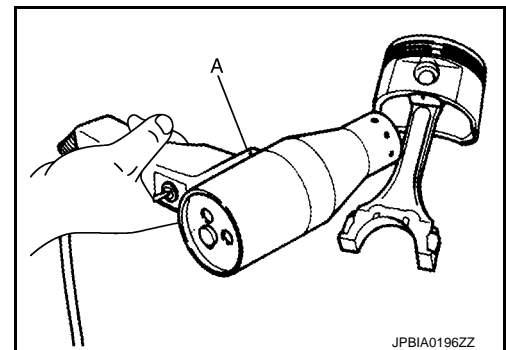

- c. Push out piston pin with stick of outer diameter approximately 20 mm (0.79 in).

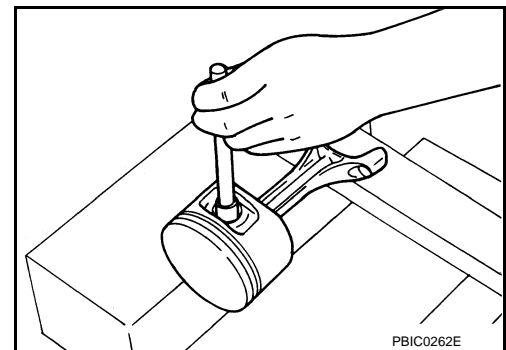

9. Remove main bearing cap bolts.

NOTE:

- Before loosening main bearing cap bolts, measure the crankshaft end play. Refer to [EM-131, "Inspection"](#).

CYLINDER BLOCK

< UNIT DISASSEMBLY AND ASSEMBLY >

- Loosen main bearing cap bolts in the reverse order shown in the figure in several different steps.

↶ : Engine front

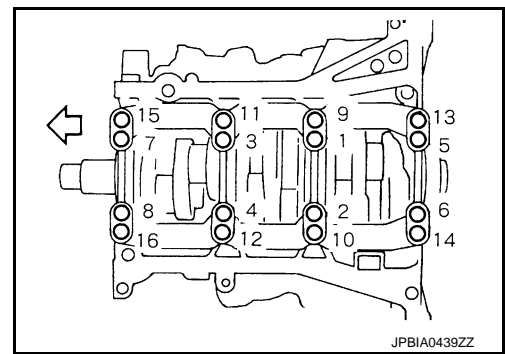

- Remove main bearing beam.

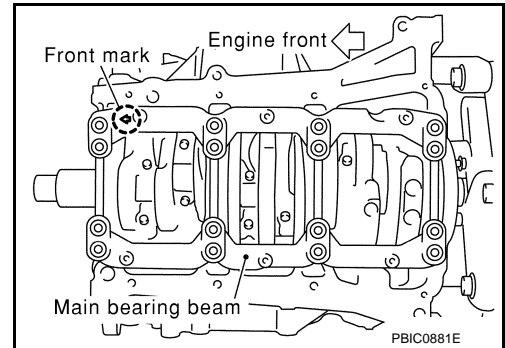

- Remove main bearing caps.

CAUTION:

Be careful not to drop main bearing, and to scratch the surface.

- Using main bearing cap bolts, remove main bearing cap while shaking it back-and-forth.

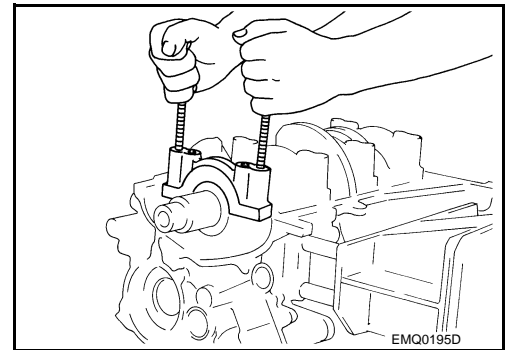

- Remove crankshaft.

- Remove main bearings and thrust bearings from cylinder block and main bearing caps.

CAUTION:

- Be careful not to drop main bearing, and to scratch the surface.**
- Identify installation positions, and store them without mixing them up.**

- Remove oil jet.

ASSEMBLY

CAUTION:

Do not reuse washers.

- Fully air-blow engine coolant and engine oil passages in cylinder block, cylinder bore and crankcase to remove any foreign material.

CAUTION:

Use a goggles to protect your eye.

A

EM

C

D

E

F

G

H

I

J

K

L

M

N

O

P

CYLINDER BLOCK

< UNIT DISASSEMBLY AND ASSEMBLY >

2. Install each plug to cylinder block as shown in the figure.

B : Water drain plug

CAUTION:

Do not reuse washers.

- Apply sealant to the thread of water drain plug (A).
Use **Anaerobic Liquid Gasket or equivalent**. Refer to [GI-22, "Recommended Chemical Products and Sealants"](#).

NOTE:

- For Canada, water drain plug (A) in the figure is not water drain plug but block heater. Refer to [EM-122, "Exploded View"](#).
- Apply sealant to the thread of connector bolt (D).
Use **Genuine RTV Silicone Sealant or equivalent**. Refer to [GI-22, "Recommended Chemical Products and Sealants"](#).
- Apply sealant to the thread of plug (C).
Use **genuine high strength thread locking sealant or equivalent**. Refer to [GI-22, "Recommended Chemical Products and Sealants"](#).

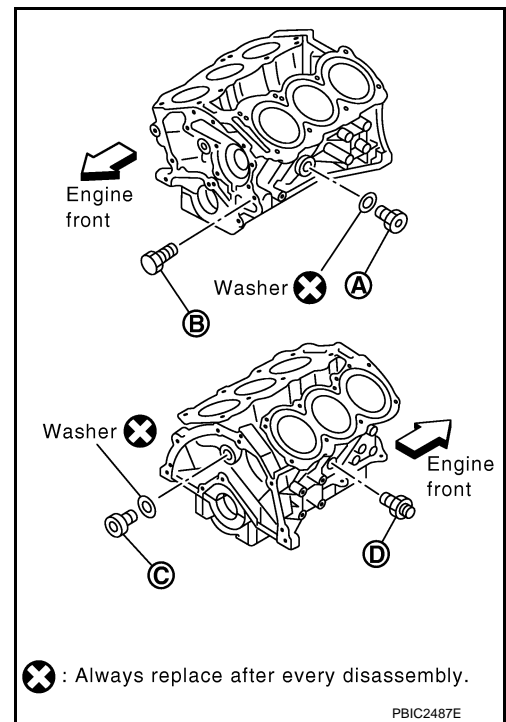

Tighten each plug and connector bolt as specified below.

Part	Washer	Tightening torque
A	Yes	62.0 N·m (6.3 kg·m, 46 ft·lb)
B	No	9.8 N·m (1.0 kg·m, 87 in·lb)
C	Yes	62.0 N·m (6.3 kg·m, 46 ft·lb)
D	No	39.2 N·m (4.0 kg·m, 29 ft·lb)

3. Install oil jet.

- Insert oil jet dowel pin (A) into cylinder block dowel pin hole, and tighten mounting bolts.

← : Engine front

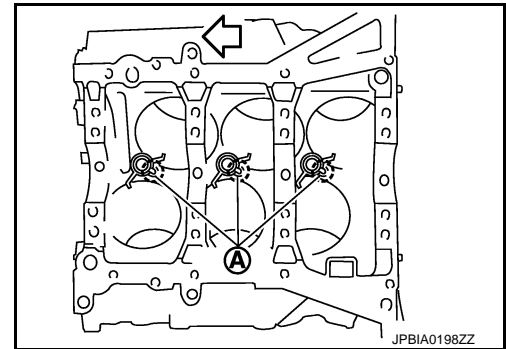

4. Install main bearings and thrust bearings as follows:

CAUTION:

Be careful not to drop main bearing, and to scratch the surface.

- Remove dust, dirt, and engine oil on bearing mating surfaces of cylinder block and main bearing caps.

CYLINDER BLOCK

< UNIT DISASSEMBLY AND ASSEMBLY >

- b. Install thrust bearings (1) to the both sides of the No. 3 journal housing on cylinder block and main bearing cap.

- A : No. 1
- B : No. 2
- C : No. 3
- D : No. 4
- F : Thrust bearing installation position
- ↔ : Engine front

- Install thrust bearings with the oil groove (E) facing crankshaft arm (outside).
- Install thrust bearing with a projection on one end on cylinder block, and thrust bearing with a projection at center on main bearing cap. Align each projection with mating notch.

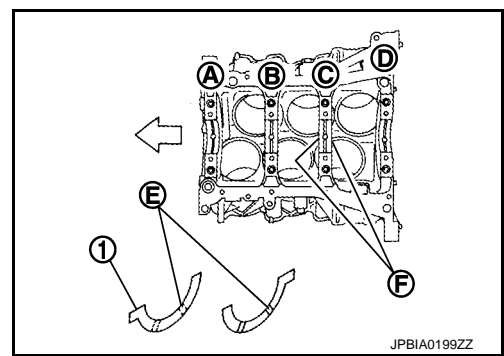

- c. Install main bearings paying attention to the direction.

- Main bearing with oil hole (B) and groove (C) goes on cylinder block. The one without them goes on main bearing cap.

- A : Cylinder block side
- D : Main bearing cap side
- ↔ : Engine front

- Before installing main bearings, apply engine oil to the bearing surface (inside). Do not apply engine oil to the back surface, but thoroughly clean it.
- When installing, align main bearing stopper protrusion to cut-out of cylinder block and main bearing caps.
- Ensure the oil holes on cylinder block and those on the corresponding bearing are aligned.

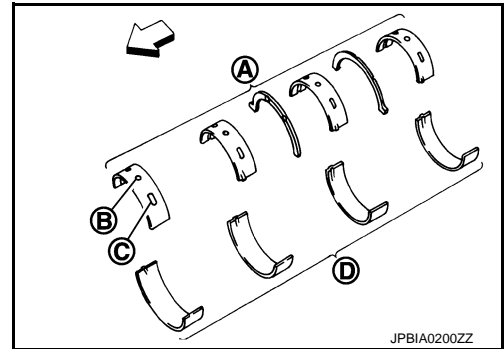

5. Install crankshaft to cylinder block.

- While turning crankshaft by hand, check that it turns smoothly.

6. Install main bearing caps.

- Main bearing caps are identified by identification mark cast on them. For installation, face front mark (E) to front side.

- A : No. 1
- B : No. 2
- C : No. 3
- D : No. 4
- ↔ : Engine front

NOTE:

Main bearing cap cannot be replaced as a single part, because it is machined together with cylinder block.

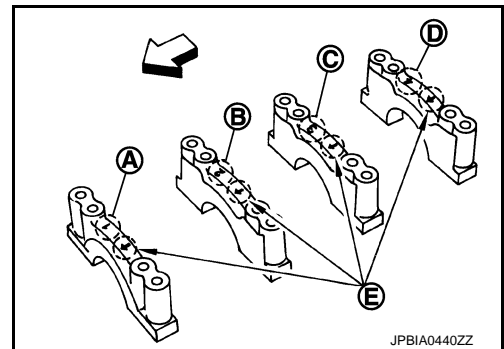

7. Install main bearing beam.

- Install main bearing beam with front mark facing downward (oil pan side).
- Install main bearing beam with front mark facing front of the engine.

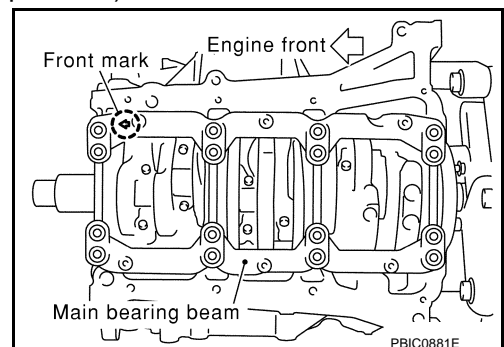

A
EM
C
D
E
F
G
H
I
J
K
L
M
N
O
P

CYLINDER BLOCK

< UNIT DISASSEMBLY AND ASSEMBLY >

8. Install main bearing cap bolts in numerical order as shown in the figure as follows:

↔ : Engine front

- Inspect the outer diameter of main bearing cap bolt. Refer to [EM-131, "Inspection"](#).
- Apply new engine oil to threads and seat surfaces of main bearing cap bolts.
- Tighten main bearing cap bolts in several different steps.

: **35.3 N·m (3.6 kg-m, 26 ft-lb)**

- Turn all main bearing cap bolts 90 degrees clockwise (angle tightening).

CAUTION:

Use the angle wrench [SST: KV10112100 (BT8653-A)] to check tightening angle. Never make judgment by visual inspection.

- After installing main bearing cap bolts, check that crankshaft can be rotated smoothly by hand.
- Check the crankshaft end play. Refer to [EM-131, "Inspection"](#).

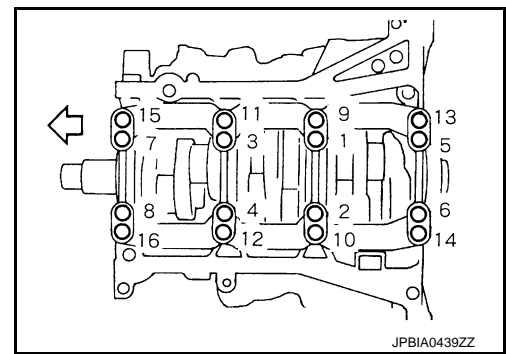

JPBIA0439ZZ

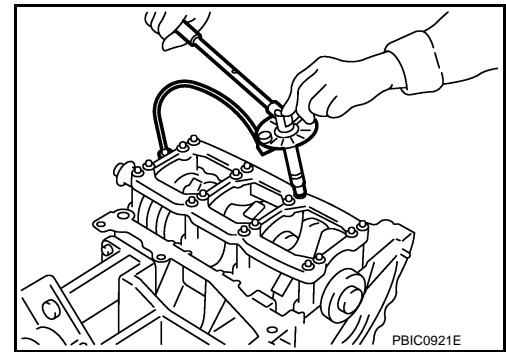

PBIC0921E

9. Install piston to connecting rod as follows:

- Using snap ring pliers, install new snap ring to the groove of piston rear side.
 - Insert it fully into groove to install.
- Install piston to connecting rod.
 - Using an industrial drier or similar tool, heat piston until piston pin can be pushed in by hand without excess force [approximately 60 to 70°C (140 to 158°F)]. From the front to the rear, insert piston pin into piston and connecting rod.
 - Assemble so that the front mark on the piston crown and the cylinder number on connecting rod are positioned as shown in the figure.
- Install new snap ring to the groove of the piston front side.
 - Insert it fully into groove to install.
 - After installing, check that connecting rod moves smoothly.

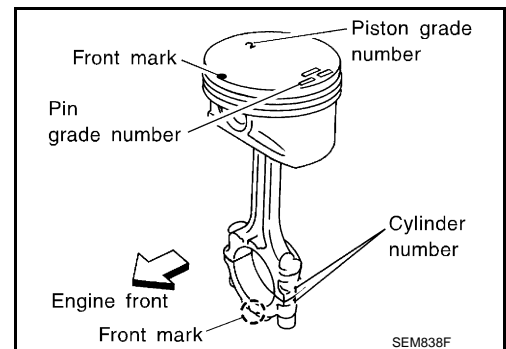

SEM838F

10. Using a piston ring expander (commercial service tool) (A), install piston rings.

CAUTION:

- When installing piston rings, be careful not to damage piston.
- Be careful not to damage piston rings by expanding them excessively.

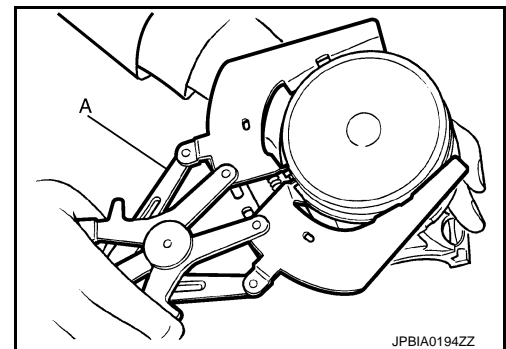

JPBIA0194ZZ

CYLINDER BLOCK

< UNIT DISASSEMBLY AND ASSEMBLY >

- If there is stamped mark on ring, mount it with marked side up.
NOTE:
If there is no stamp on ring, no specific orientation is required for installation.

Stamped mark:

Top ring (A) : —
Second ring (B) : 2 R

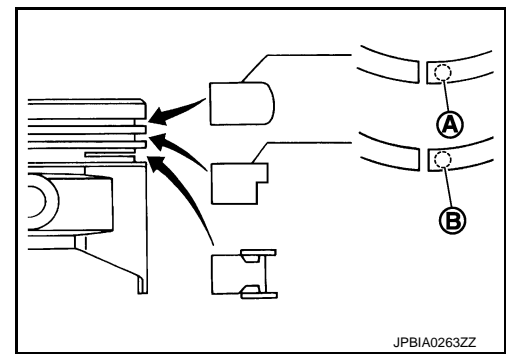

- Position each ring with the gap as shown in the figure referring to the piston front mark (D).

C : Top ring gap
E : Oil ring upper or lower rail gap (either of them)
F : Second ring and oil ring spacer gap
a : 90 degrees
b : 45 degrees

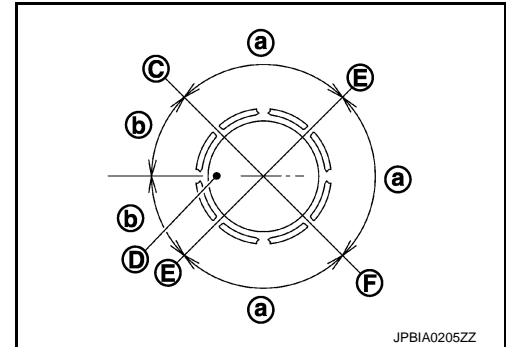

- Check the piston rings side clearance. Refer to [EM-131, "Inspection"](#).

11. Install connecting rod bearings to connecting rod and connecting rod bearing cap.

CAUTION:

Be careful not to drop connecting rod bearing, and to scratch the surface.

- Before installing connecting rod bearings, apply engine oil to the bearing surface (inside). Do not apply engine oil to the back surface, but thoroughly clean it.
- When installing, align connecting rod bearing stopper protrusion (B) with cutout (C) of connecting rod and connecting rod bearing cap to install.
- Ensure the oil hole (A) on connecting rod and that on the corresponding bearing are aligned.

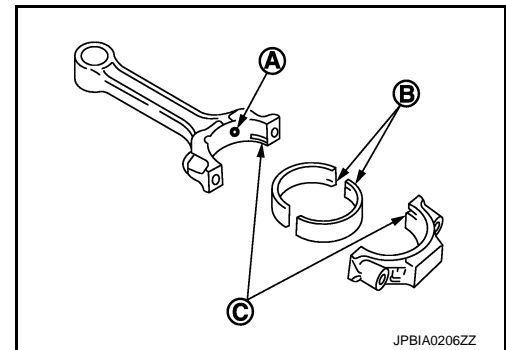

12. Install piston and connecting rod assembly to crankshaft.

- Position crankshaft pin corresponding to connecting rod to be installed onto the bottom dead center.
- Apply engine oil sufficiently to the cylinder bore, piston and crankshaft pin journal.
- Match the cylinder position with the cylinder number on connecting rod to install.
- Be sure that front mark on piston crown is facing front of engine.
- Using a piston ring compressor [SST: EM03470000 (J-8037)] (A) or suitable tool, install piston with the front mark on the piston crown facing the front of the engine.

CAUTION:

Be careful not to damage the cylinder wall and crankshaft pin, resulting from an interference of the connecting rod big end.

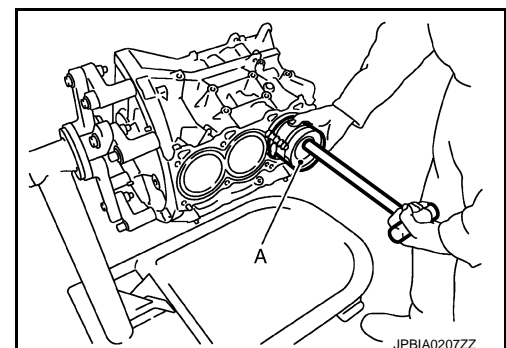

CYLINDER BLOCK

< UNIT DISASSEMBLY AND ASSEMBLY >

13. Install connecting rod bearing cap.

- Match the stamped cylinder number marks on connecting rod with those on connecting rod bearing cap to install.

- A : Sample codes
- B : Bearing stopper groove
- C : Small-end diameter grade
- D : Standard stamp
- E : Weight grade
- F : Cylinder No.
- G : Management code
- I : Management code

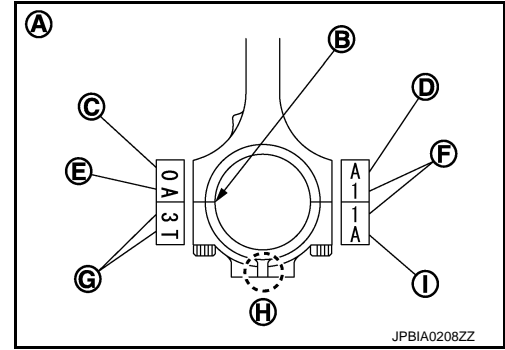

- Be sure that front mark (H) on connecting rod bearing cap is facing front of the engine.

14. Tighten connecting rod bolt as follows:

- Inspect the outer diameter of connecting rod bolt. Refer to [EM-131. "Inspection"](#).
- Apply engine oil to the threads and seats of connecting rod bolts.
- Tighten connecting rod bolts.

: 19.6 N·m (2.0 kg-m, 14 ft-lb)

- Then tighten all connecting rod bolts 90 degrees clockwise (angle tightening).

CAUTION:

Always use the angle wrench [SST: KV10112100 (BT8653-A)]. Avoid tightening based on visual check alone.

- After tightening connecting rod bolts, check that crankshaft rotates smoothly.
- Check the connecting rod side clearance. Refer to [EM-131. "Inspection"](#).

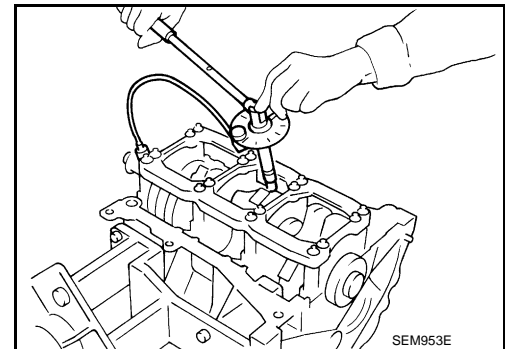

15. Install baffle plate to main bearing beam.

16. Install new rear oil seal retainer to cylinder block. Refer to [EM-109. "REAR OIL SEAL : Removal and Installation"](#).

17. Install pilot converter.

- With drift [outer diameter: approximately 33 mm (1.30 in)], press-fit as far as it will go.

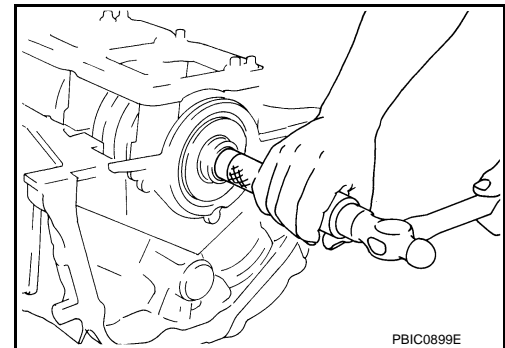

CYLINDER BLOCK

< UNIT DISASSEMBLY AND ASSEMBLY >

- Press-fit pilot converter with its chamfer facing crankshaft as shown in the figure.

⇐ : Crankshaft side

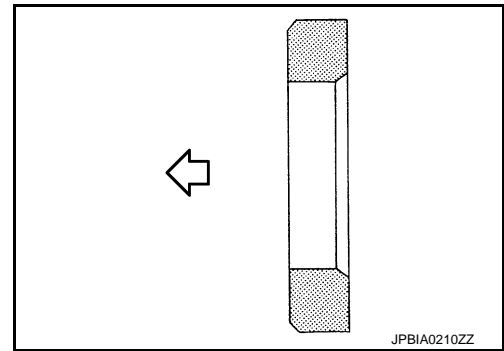

18. Install knock sensors.

- Install knock sensor so that connector faces the rear of the engine.

A : Bank 1

B : Bank 2

⇐ : Engine front

- After installing knock sensor, connect harness connector, and lay it out to rear of engine.

CAUTION:

- **Never tighten mounting bolts while holding connector.**
- **If any impact by dropping is applied to knock sensor, replace it with new one.**

NOTE:

- Check that there is no foreign material on the cylinder block mating surface and the back surface of knock sensor.
- Check that knock sensor does not interfere with other parts.

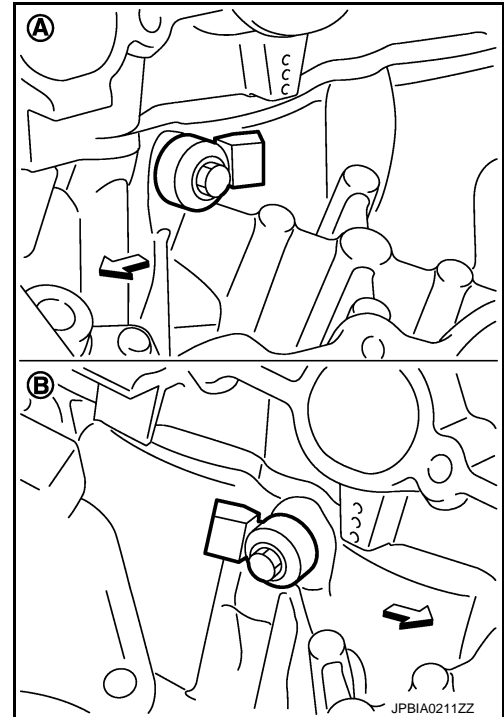

19. Note the following, assemble in the reverse order of disassembly after this step.

Drive plate

- When installing drive plate to crankshaft, be sure to correctly align crankshaft side dowel pin and drive plate side dowel pin hole.
- If these are not aligned correctly, engine runs roughly and "MIL" turns on.
- Install drive plate (2) and reinforcement plate (3) as shown in the figure.

1 : Ring gear

4 : Pilot converter

5 : Crankshaft

A : Rounded

⇐ : Engine front

- Holding ring gear with the pulley holder (commercial service tool).
- Tighten mounting bolts crosswise over several times.

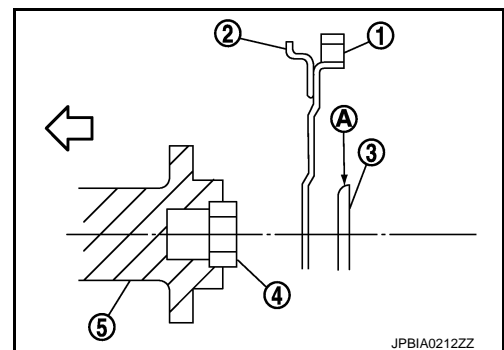

Inspection

INFOID:000000006260657

CRANKSHAFT END PLAY

CYLINDER BLOCK

< UNIT DISASSEMBLY AND ASSEMBLY >

- Measure the clearance between thrust bearings and crankshaft arm when crankshaft is moved fully forward or backward with a dial indicator.

Standard and limit : Refer to [EM-151, "Cylinder Block"](#).

- If the measured value exceeds the limit, replace thrust bearings, and measure again. If it still exceeds the limit, replace crankshaft also.

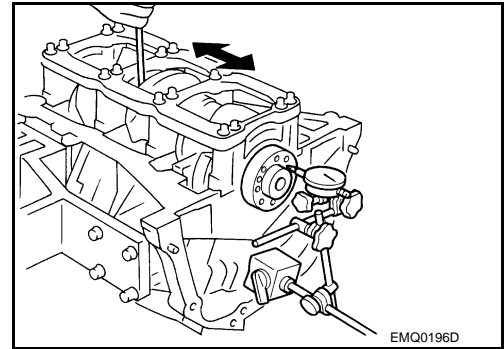

CONNECTING ROD SIDE CLEARANCE

- Measure the side clearance between connecting rod and crankshaft arm with a feeler gauge (A).

Standard and limit : Refer to [EM-151, "Cylinder Block"](#).

- If the measured value exceeds the limit, replace connecting rod, and measure again. If it still exceeds the limit, replace crankshaft also.

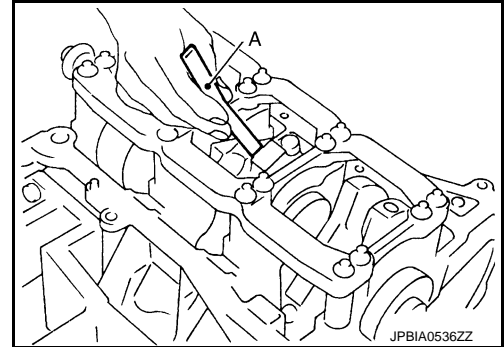

PISTON TO PISTON PIN OIL CLEARANCE

Piston Pin Hole Diameter

Measure the inner diameter of piston pin hole with an inside micrometer (A).

Standard : Refer to [EM-151, "Cylinder Block"](#).

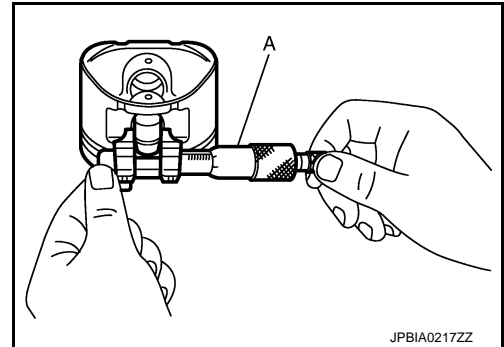

Piston Pin Outer Diameter

Measure the outer diameter of piston pin with a micrometer (A).

Standard : Refer to [EM-151, "Cylinder Block"](#).

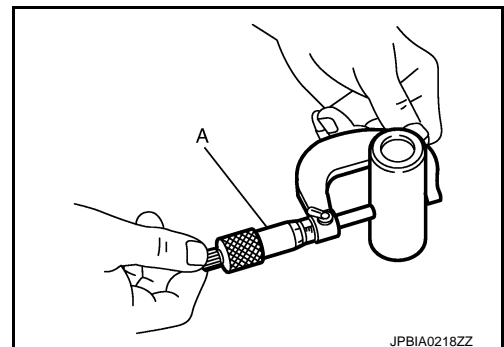

Piston to Piston Pin Oil Clearance

(Piston to piston pin oil clearance) = (Piston pin hole diameter) – (Piston pin outer diameter)

Standard : Refer to [EM-151, "Cylinder Block"](#).

- If the calculated value is out of the standard, replace piston and piston pin assembly.
- When replacing piston and piston pin assembly, refer to [EM-141, "Description"](#).

NOTE:

- Piston is available together with piston pin as assembly.

CYLINDER BLOCK

< UNIT DISASSEMBLY AND ASSEMBLY >

- Piston pin (piston pin hole) grade is provided only for the parts installed at the plant. For service parts, no piston pin grades can be selected. (Only "0" grade is available.)

PISTON RING SIDE CLEARANCE

- Measure the side clearance of piston ring (1) and piston ring groove with a feeler gauge (C).

A : NG

B : OK

Standard and limit : Refer to [EM-151, "Cylinder Block"](#).

- If the measured value exceeds the limit, replace piston ring, and measure again. If it still exceeds the limit, replace piston also.

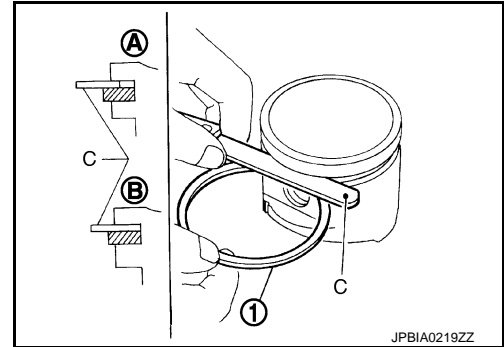

PISTON RING END GAP

- Check that the cylinder bore inner diameter is within the specification. Refer to [EM-151, "Cylinder Block"](#).
- Lubricate with new engine oil to piston (1) and piston ring (2), and then insert piston ring until middle of cylinder with piston, and measure the piston ring end gap with a feeler gauge (B).

A : Press-fit

C : Measuring point

Standard and limit : Refer to [EM-151, "Cylinder Block"](#).

- If the measured value exceeds the limit, replace piston ring, and measure again. If it still exceeds the limit, rebore cylinder and use oversize piston and piston rings.

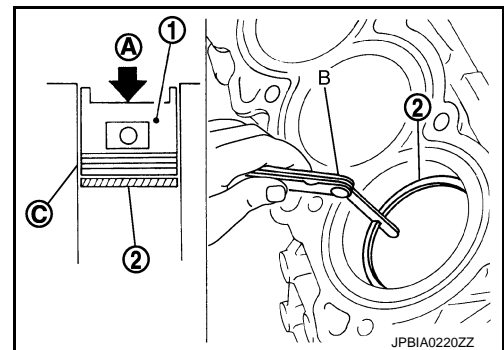

CONNECTING ROD BEND AND TORSION

- Check with a connecting rod aligner.

A : Bend

B : Torsion

C : Feeler gauge

Bend limit
Torsion limit : Refer to [EM-151, "Cylinder Block"](#).

- If it exceeds the limit, replace connecting rod assembly.

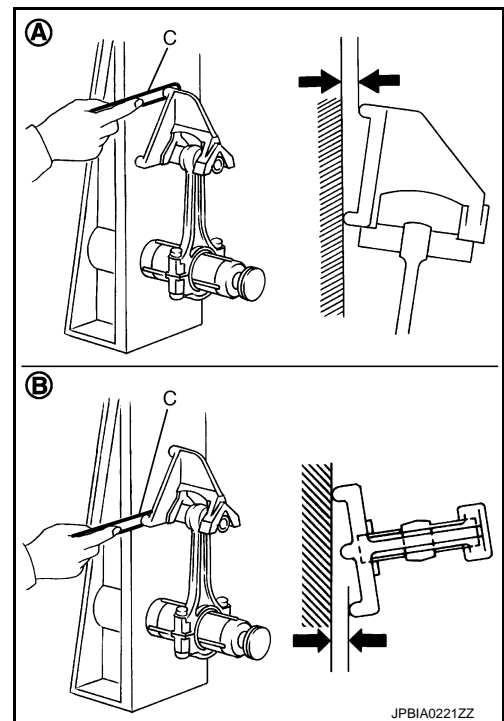

CONNECTING ROD BIG END DIAMETER

- Install connecting rod bearing cap without installing connecting rod bearing, and tightening connecting rod bolts to the specified torque. Refer to [EM-123, "Disassembly and Assembly"](#) for the tightening procedure.

CYLINDER BLOCK

< UNIT DISASSEMBLY AND ASSEMBLY >

- Measure the inner diameter of connecting rod big end with an inside micrometer.

1 : Connecting rod

Standard : Refer to [EM-151, "Cylinder Block"](#).

- If out of the standard, replace connecting rod assembly.

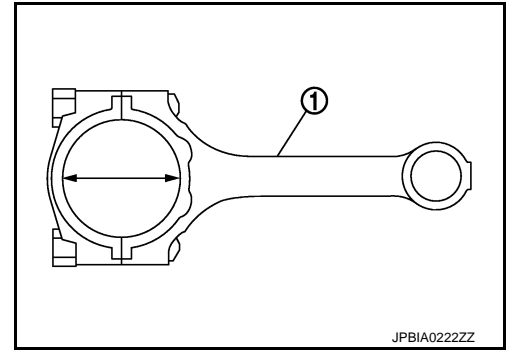

CONNECTING ROD BUSHING OIL CLEARANCE

Connecting Rod Bushing Inner Diameter

Measure the inner diameter of connecting rod bushing with an inside micrometer (A).

Standard : Refer to [EM-151, "Cylinder Block"](#).

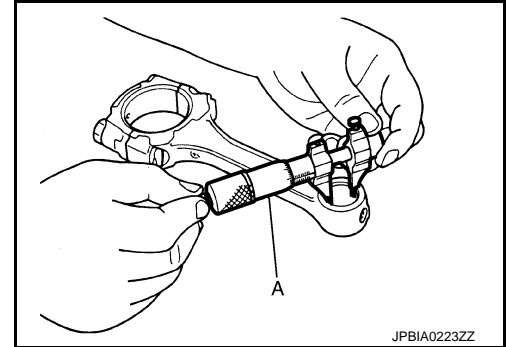

Piston Pin Outer Diameter

Measure the outer diameter of piston pin with a micrometer (A).

Standard : Refer to [EM-151, "Cylinder Block"](#).

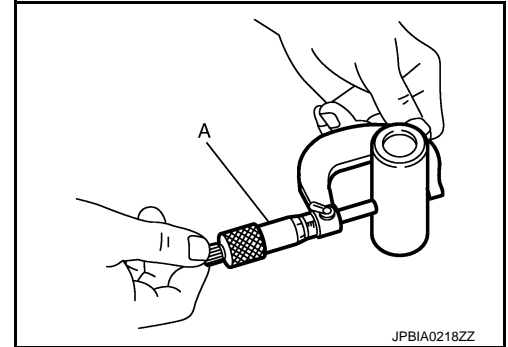

Connecting Rod Bushing Oil Clearance

(Connecting rod bushing oil clearance) = (Connecting rod bushing inner diameter) – (Piston pin outer diameter)

Standard and limit : Refer to [EM-151, "Cylinder Block"](#).

- If the calculated value exceeds the limit, replace connecting rod assembly and/or piston and piston pin assembly.
- If replacing piston and piston pin assembly, refer to [EM-141, "Description"](#).
- If replacing connecting rod assembly, refer to [EM-142, "Connecting Rod Bearing"](#) to select the connecting rod bearing.

- A : Sample codes
- B : Bearing stopper groove
- C : Small-end diameter grade
- D : Standard stamp
- E : Weight grade
- F : Cylinder No.
- G : Management code

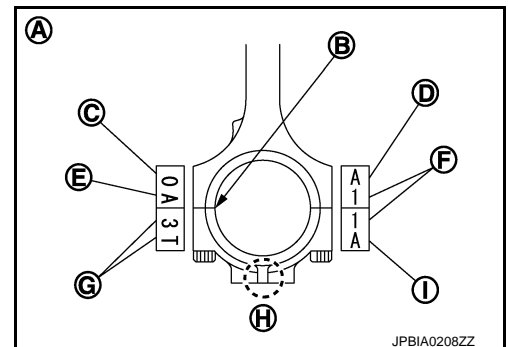

CYLINDER BLOCK

< UNIT DISASSEMBLY AND ASSEMBLY >

- H : Front mark
- I : Management code

Factory installed parts grading:

- Service parts apply only to grade "0".

- A : Piston grade number
- B : Front mark
- C : Piston pin grade number
- D : Identification code

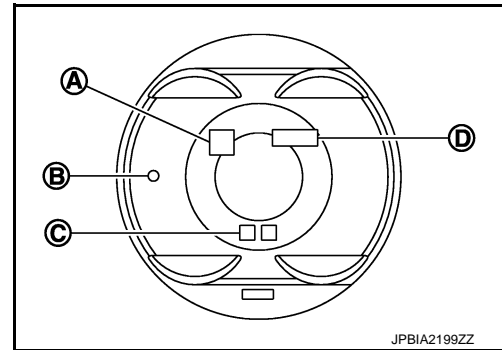

Unit: mm (in)

Grade	0	1
Connecting rod bushing inner diameter *	22.000 - 22.006 (0.8661 - 0.8664)	22.006 - 22.012 (0.8664 - 0.8666)
Piston pin hole diameter	21.993 - 21.999 (0.8659 - 0.8661)	21.999 - 22.005 (0.8661 - 0.8663)
Piston pin outer diameter	21.989 - 21.995 (0.8657 - 0.8659)	21.995 - 22.001 (0.8659 - 0.8662)

*: After installing in connecting rod

CYLINDER BLOCK DISTORTION

- Using a scraper, remove gasket on the cylinder block surface, and also remove engine oil, scale, carbon, or other contamination.

CAUTION:

Be careful not to allow gasket flakes to enter engine oil or engine coolant passages.

- Measure the distortion on the cylinder block upper face at some different points in six directions (C), (D), (E), (F), (G), and (H) with a straightedge (A) and a feeler gauge (B).

Limit : Refer to [EM-151, "Cylinder Block"](#).

- If it exceeds the limit, replace cylinder block.

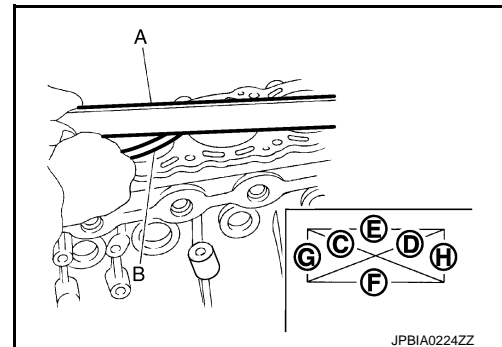

MAIN BEARING HOUSING INNER DIAMETER

- Install main bearing caps and main bearing beam without installing main bearings, and tighten main bearing cap bolts to the specified torque. Refer to [EM-123, "Disassembly and Assembly"](#) for the tightening procedure.
- Measure the inner diameter of main bearing housing with a bore gauge.

Standard : Refer to [EM-151, "Cylinder Block"](#).

- If out of the standard, replace cylinder block (1) and main bearing caps (2) as assembly.

NOTE:

Cylinder block cannot be replaced as a single part, because it is machined together with main bearing caps.

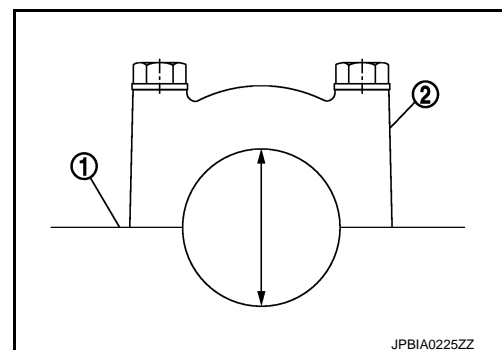

CYLINDER BLOCK

< UNIT DISASSEMBLY AND ASSEMBLY >

PISTON TO CYLINDER BORE CLEARANCE

Cylinder Bore inner Diameter

- Using a bore gauge, measure cylinder bore for wear, out-of-round and taper at six different points on each cylinder. [(A) and (B) directions at (C), (D) and (E)] is in longitudinal direction of engine.

f : 10 mm (0.39 in)

g : 60 mm (2.36 in)

h : 120 mm (4.72 in)

Standard and limit : Refer to [EM-151, "Cylinder Block"](#).

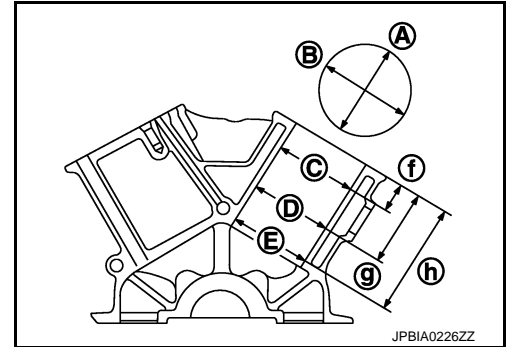

- If the measured value exceeds the limit, or if there are scratches and/or seizure on the cylinder inner wall, hone or rebore the inner wall.
- Oversize piston is provided. When using oversize piston, rebore cylinder so that the clearance of the piston to cylinder bore satisfies the standard.

CAUTION:

When using oversize piston, use oversize pistons for all cylinders with oversize piston rings.

Oversize (O/S) : 0.2 mm (0.008 in)

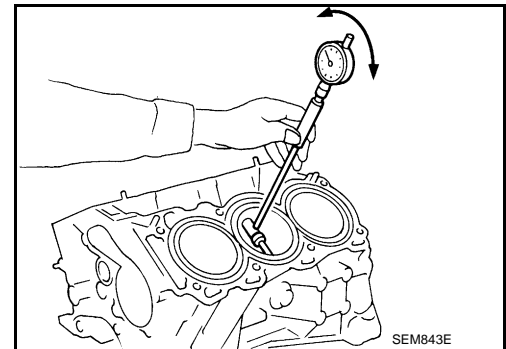

Piston Skirt Diameter

Measure the outer diameter of piston skirt with a micrometer (A).

Measure point
Standard : Refer to [EM-151, "Cylinder Block"](#).

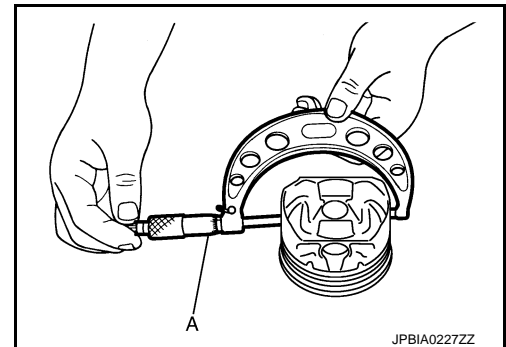

Piston-to-Cylinder Bore Clearance

Calculate by piston skirt diameter and cylinder bore inner diameter [direction (B), position (D)].

A : Direction A

C : Position C

E : Position E

f : 10 mm (0.39 in)

g : 60 mm (2.36 in)

h : 120 mm (4.72 in)

(Clearance) = (Cylinder bore inner diameter) – (Piston skirt diameter).

Standard and limit : Refer to [EM-151, "Cylinder Block"](#).

- If the calculated value exceeds the limit, replace piston and piston pin assembly. Refer to [EM-141, "Piston"](#).

Reboring Cylinder Bore

- Cylinder bore size is determined by adding piston to cylinder bore clearance to piston skirt diameter.

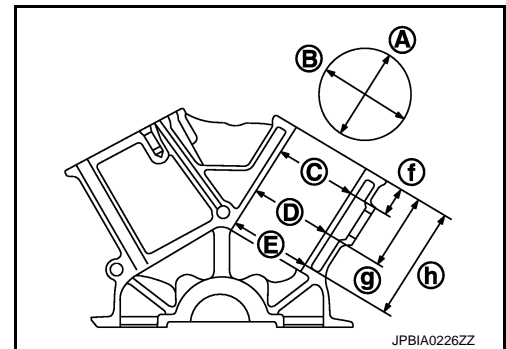

CYLINDER BLOCK

< UNIT DISASSEMBLY AND ASSEMBLY >

Rebored size calculation: $D = A + B - C$

where,

A: Piston skirt diameter as measured

B: Piston to cylinder bore clearance (standard value)

C: Honing allowance 0.02 mm (0.0008 in)

D: Bored diameter

2. Install main bearing caps and main bearing beam, and tighten to the specified torque. Otherwise, cylinder bores may be distorted in final assembly.

3. Cut cylinder bores.

NOTE:

- When any cylinder needs boring, all other cylinders must also be bored.
- Do not cut too much out of cylinder bore at a time. Cut only 0.05 mm (0.0020 in) or so in diameter at a time.

4. Hone cylinders to obtain the specified piston to cylinder bore clearance.

5. Measure finished cylinder bore for the out-of-round and taper.

NOTE:

Measurement should be done after cylinder bore cools down.

CRANKSHAFT MAIN JOURNAL DIAMETER

- Measure the outer diameter of crankshaft main journals with a micrometer.

Standard : Refer to [EM-151, "Cylinder Block"](#).

- If out of the standard, measure the main bearing oil clearance. Then use undersize bearing. Refer to [EM-143, "Main Bearing"](#).

CRANKSHAFT PIN JOURNAL DIAMETER

- Measure the outer diameter of crankshaft pin journal with a micrometer (A).

Standard : Refer to [EM-151, "Cylinder Block"](#).

- If out of the standard, measure the connecting rod bearing oil clearance. Then use undersize bearing. Refer to [EM-142, "Connecting Rod Bearing"](#).

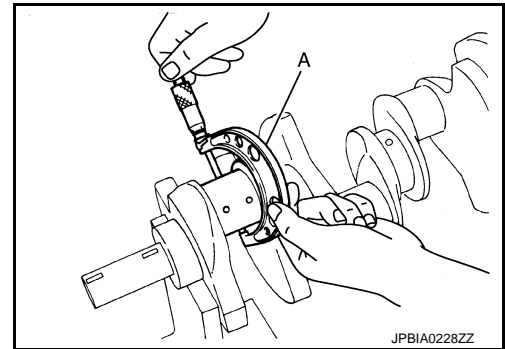

CRANKSHAFT OUT-OF-ROUND AND TAPER

- Measure the dimensions at four different points as shown in the figure on each main journal and pin journal with a micrometer.
- Out-of-round is indicated by the difference in the dimensions between (d) and (c) at (a) and (b).
- Taper is indicated by the difference in the dimensions between.

Limit : Refer to [EM-151, "Cylinder Block"](#).

- If the measured value exceeds the limit, correct or replace crankshaft.
- If corrected, measure the bearing oil clearance of the corrected main journal and/or pin journal. Then select the main bearing and/or connecting rod bearing. Refer to [EM-143, "Main Bearing"](#) and/or [EM-142, "Connecting Rod Bearing"](#).

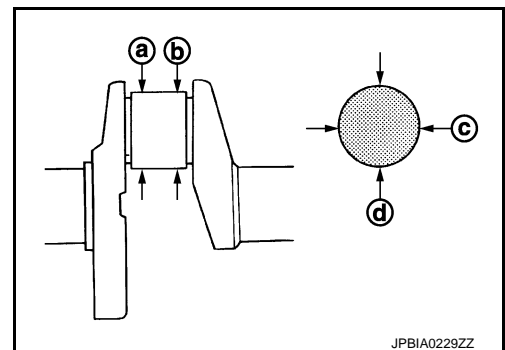

CRANKSHAFT RUNOUT

- Place V-block on precise flat table, and support the journals on the both end of crankshaft.

CYLINDER BLOCK

< UNIT DISASSEMBLY AND ASSEMBLY >

- Place a dial indicator straight up on the No. 3 journal.
- While rotating crankshaft, read the movement of the pointer on a dial indicator. (Total indicator reading)

Standard and limit : Refer to [EM-151, "Cylinder Block"](#).

- If it exceeds the limit, replace crankshaft.

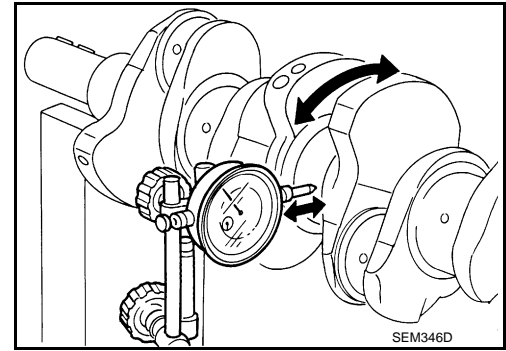

CONNECTING ROD BEARING OIL CLEARANCE

Method by Calculation

- Install connecting rod bearings (1) to connecting rod (2) and connecting rod cap, and tighten connecting rod bolts to the specified torque. Refer to [EM-123, "Disassembly and Assembly"](#) for the tightening procedure.
 - Measure the inner diameter of connecting rod bearing with an inside micrometer.
- (Oil clearance) = (Connecting rod bearing inner diameter) – (Crankshaft pin journal diameter)

Standard and limit : Refer to [EM-155, "Connecting Rod Bearing"](#).

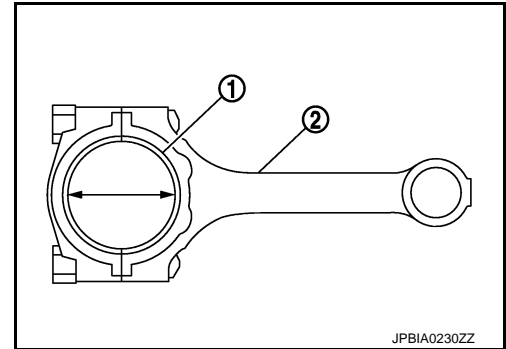

- If the calculated value exceeds the limit, select proper connecting rod bearing according to connecting rod big end diameter and crankshaft pin journal diameter to obtain the specified bearing oil clearance. Refer to [EM-142, "Connecting Rod Bearing"](#).

Method of Using Plastigage

- Remove oil and dust on crankshaft pin journal and the surfaces of each bearing completely.
- Cut a plastigage slightly shorter than the bearing width, and place it in crankshaft axial direction, avoiding oil holes.
- Install connecting rod bearings to connecting rod and connecting rod bearing cap, and tighten connecting rod bolts to the specified torque. Refer to [EM-123, "Disassembly and Assembly"](#) for the tightening procedure.

CAUTION:

Never rotate crankshaft.

- Remove connecting rod bearing cap and bearings, and using the scale on the plastigage bag, measure the plastigage width.

NOTE:

The procedure when the measured value exceeds the limit is same as that described in the "Method by Calculation".

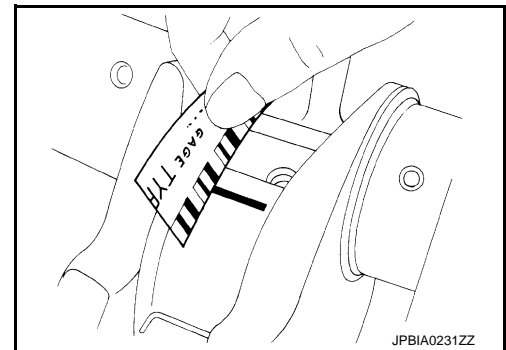

MAIN BEARING OIL CLEARANCE

Method by Calculation

CYLINDER BLOCK

< UNIT DISASSEMBLY AND ASSEMBLY >

- Install main bearings (3) to cylinder block (1) and main bearing caps (2), and main bearing cap bolts with main bearing beam to the specified torque. Refer to [EM-123, "Disassembly and Assembly"](#) for the tightening procedure.
- Measure the inner diameter of main bearing with a bore gauge.
(Oil clearance) = (Main bearing inner diameter) – (Crankshaft main journal diameter)

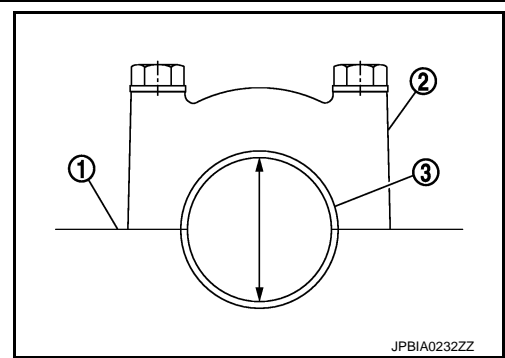

Standard and limit : Refer to [EM-154, "Main Bearing"](#).

- If the calculated value exceeds the limit, select proper main bearing according to main bearing inner diameter and crankshaft main journal diameter to obtain the specified bearing oil clearance. Refer to [EM-143, "Main Bearing"](#).

Method of Using Plastigage

- Remove engine oil and dust on crankshaft journal and the surfaces of each bearing completely.
- Cut a plastigage slightly shorter than the bearing width, and place it in crankshaft axial direction, avoiding oil holes.
- Install main bearing to cylinder block and main bearing caps, and tighten main bearing cap bolts with main bearing beam to the specified torque. Refer to [EM-123, "Disassembly and Assembly"](#) for the tightening procedure.

CAUTION:

Never rotate crankshaft.

- Remove main bearing caps and bearings, and using the scale on the plastigage bag, measure the plastigage width.

NOTE:

The procedure when the measured value exceeds the limit is same as that described in the "Method by Calculation".

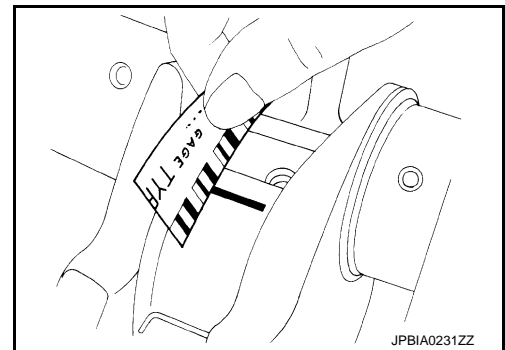

MAIN BEARING CRUSH HEIGHT

- When main bearing cap is removed after being tightened to the specified torque with main bearings (1) installed, the tip end of bearing must protrude. Refer to [EM-123, "Disassembly and Assembly"](#) for the tightening procedure.

A : Crush height

Standard : There must be crush height.

- If the standard is not met, replace main bearings.

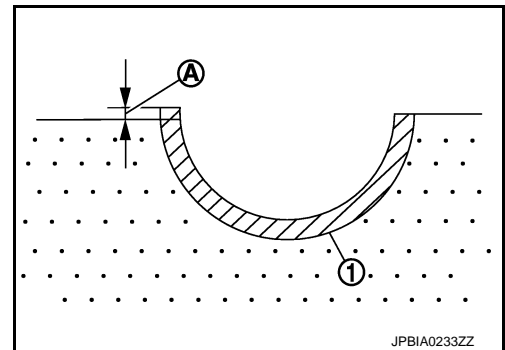

CONNECTING ROD BEARING CRUSH HEIGHT

- When connecting rod bearing cap is removed after being tightened to the specified torque with connecting rod bearings (1) installed, the tip end of bearing must protrude. Refer to [EM-123, "Disassembly and Assembly"](#) for the tightening procedure.

A : Crush height

Standard : There must be crush height.

- If the standard is not met, replace connecting rod bearings.

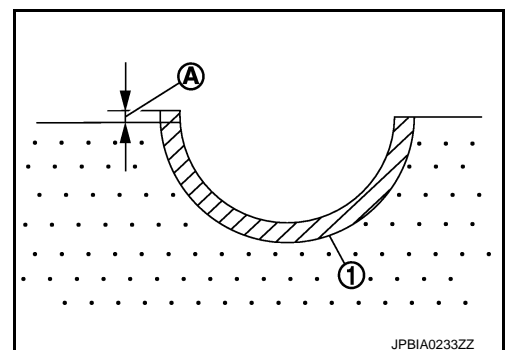

CYLINDER BLOCK

< UNIT DISASSEMBLY AND ASSEMBLY >

MAIN BEARING CAP BOLT OUTER DIAMETER

- Measure the outer diameters (c), (d) at two positions as shown in the figure.

a : 20 mm (0.79 in)

b : 30 mm (1.18 in)

e : 10 mm (0.39 in)

- If reduction appears in (a) range, regard it (c).

Limit [(d) – (c)] : 0.11 mm (0.0043 in)

- If it exceeds the limit (large difference in dimensions), replace main bearing cap bolt with new one.

CONNECTING ROD BOLT OUTER DIAMETER

- Measure the outer diameter (d) at position shown in the figure.
- If the reduction appears in a position other than (d), regard it as (d).

Standard : 7.90 - 8.00 mm (0.3110 - 0.3150 in)

Limit : 7.75 mm (0.3051 in)

- When (d) exceeds the limit (when it becomes thinner), replace connecting rod bolt with new one.

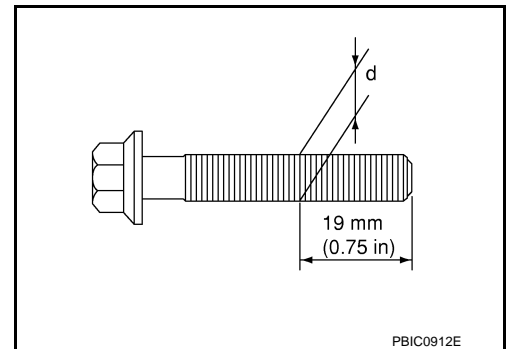
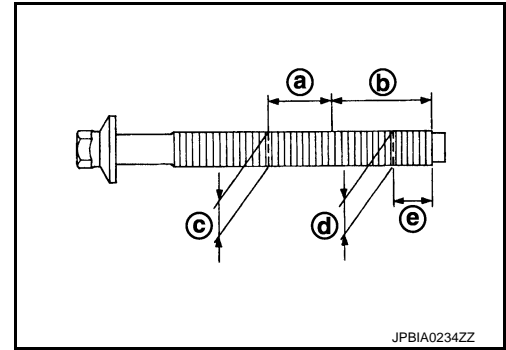

DRIVE PLATE

- Check drive plate and signal plate for deformation or damage.

CAUTION:

- **Never disassemble drive plate.**
- **Never place drive plate with signal plate facing down.**
- **When handling signal plate, take care not to damage or scratch it.**
- **Handle signal plate in a manner that prevents it from becoming magnetized.**
- If anything is found, replace drive plate.

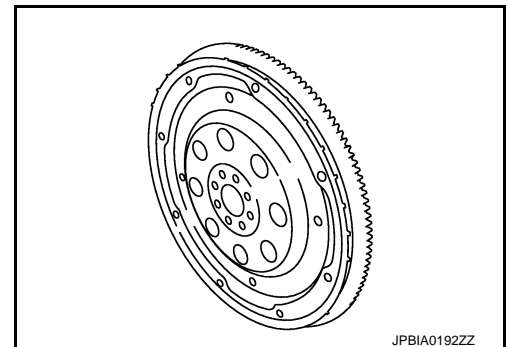

OIL JET

- Check nozzle for deformation and damage.
- Blow compressed air from nozzle, and check for clogs.
- If it is not satisfied, clean or replace oil jet.

OIL JET RELIEF VALVE

- Using a clean plastic stick, press check valve in oil jet relief valve. Check that valve moves smoothly with proper reaction force.
- If it is not satisfied, replace oil jet relief valve.

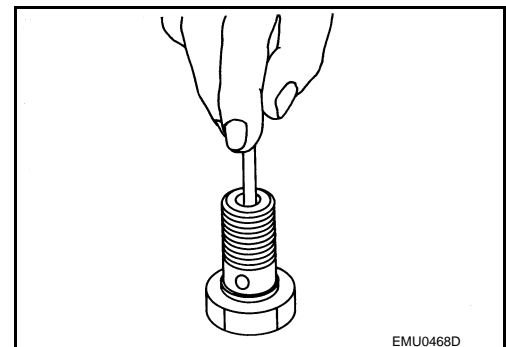

HOW TO SELECT PISTON AND BEARING

< UNIT DISASSEMBLY AND ASSEMBLY >

HOW TO SELECT PISTON AND BEARING

Description

INFOID:000000006260658

Selection points	Selection parts	Selection items	Selection methods
Between cylinder block and crankshaft	Main bearing	Main bearing grade (bearing thickness)	Determined by match of cylinder block bearing housing grade (inner diameter of housing) and crankshaft journal grade (outer diameter of journal)
Between crankshaft and connecting rod	Connecting rod bearing	Connecting rod bearing grade (bearing thickness)	Combining service grades for connecting rod big end diameter and crankshaft pin outer diameter determine connecting rod bearing selection.
Between cylinder block and piston	Piston and piston pin assembly (Piston is available together with piston pin as assembly.)	Piston grade (piston skirt diameter)	Piston grade = cylinder bore grade (inner diameter of bore)
Between piston and connecting rod*	—	—	—

*: For the service parts, the grade for fitting cannot be selected between piston pin and connecting rod. (Only "0" grade is available.) The information at the shipment from the plant is described as a reference.

- The identification grade stamped on each part is the grade for the dimension measured in new condition. This grade cannot apply to reused parts.
- For reused or repaired parts, measure the dimension accurately. Determine the grade by comparing the measurement with the values of each selection table.
- For details of the measurement method of each part, the reuse standards and the selection method of the selective fitting parts, refer to the text.

Piston

INFOID:000000006260659

WHEN NEW CYLINDER BLOCK IS USED

Check the cylinder bore grade ("1", "2" or "3") on rear side of cylinder block, and select piston of the same grade.

NOTE:

Piston is available with piston pin as a set for the service part. (Only "0" grade piston pin is available.)

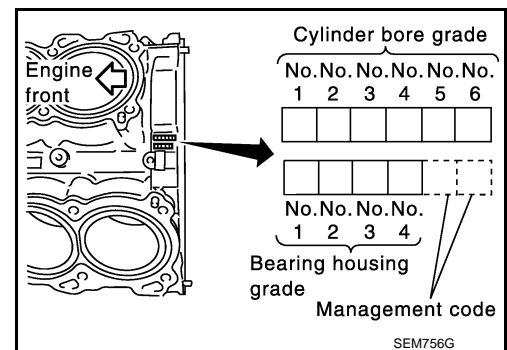

WHEN NEW CYLINDER BLOCK IS REUSED

1. Measure the cylinder bore inner diameter. Refer to [EM-131, "Inspection"](#).
2. Determine the bore grade by comparing the measurement with the values under the cylinder bore inner diameter of the "PISTON SELECTION TABLE".

HOW TO SELECT PISTON AND BEARING

< UNIT DISASSEMBLY AND ASSEMBLY >

3. Select piston of the same grade.

- A : Piston grade number
- B : Front mark
- C : Piston pin grade number
- D : Identification code

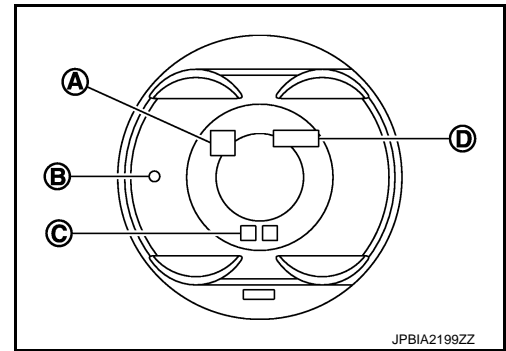

PISTON SELECTION TABLE

Unit: mm (in)

Grade	1	2	3
Cylinder bore inner diameter	95.500 - 95.510 (3.7598 - 3.7602)	95.510 - 95.520 (3.7602 - 3.7606)	95.520 - 95.530 (3.7606 - 3.7610)
Piston skirt diameter	95.480 - 95.490 (3.7590 - 3.7594)	95.490 - 95.500 (3.7594 - 3.7598)	95.500 - 95.510 (3.7598 - 3.7602)

NOTE:

- Piston is available together with piston pin as assembly.
- Piston pin (piston pin hole) grade is provided only for the parts installed at the plant. For service parts, no piston pin grades can be selected. (Only "0" grade is available.)
- No second grade mark is available on piston.

Connecting Rod Bearing

INFOID:000000006260660

WHEN NEW CONNECTING ROD AND CRANKSHAFT ARE USED

- Check pin diameter grade ("0", "1" or "2") on front of crankshaft, and select connecting rod bearing of the same grade.

- A : Journal diameter grade No. 1
- B : Journal diameter grade No. 2
- C : Journal diameter grade No. 3
- D : Journal diameter grade No. 4
- E : Pin diameter grade No. 1
- F : Pin diameter grade No. 2
- G : Pin diameter grade No. 3
- H : Pin diameter grade No. 4
- I : Pin diameter grade No. 5
- J : Pin diameter grade No. 6
- K : Identification

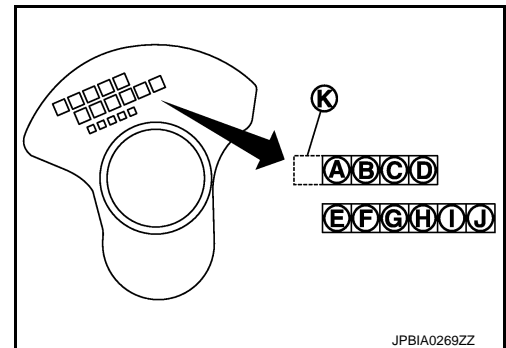

NOTE:

There is no grading for connecting rod big end diameter.

WHEN CONNECTING ROD AND CRANKSHAFT ARE REUSED

1. Measure the connecting rod big end diameter. Refer to [EM-131. "Inspection"](#).
2. Check that the connecting rod big end diameter is within the standard value.
3. Measure the crankshaft pin journal diameter. Refer to [EM-131. "Inspection"](#).
4. Determine the grade of crankshaft pin diameter grade by corresponding to the measured dimension in "Crankshaft pin journal diameter" column of "CONNECTING ROD BEARING SELECTION TABLE".
5. Select connecting rod bearing of the same grade.

CONNECTING ROD BEARING SELECTION TABLE

Unit: mm (in)

Connecting rod big end diameter	55.000 - 55.013 (2.1654 - 2.1659)
---------------------------------	-----------------------------------

HOW TO SELECT PISTON AND BEARING

< UNIT DISASSEMBLY AND ASSEMBLY >

Unit: mm (in)

Crankshaft		Connecting rod bearing		
Crankshaft pin journal diameter	Grade (Mark)	Dimension (Bearing thickness range)	Bearing grade No.	Color
51.968 - 51.974 (2.0460 - 2.0462)	0	1.500 - 1.503 (0.0591 - 0.0592)	STD 0	Black
51.962 - 51.968 (2.0457 - 2.0460)	1	1.503 - 1.506 (0.0592 - 0.0593)	STD 1	Brown
51.956 - 51.962 (2.0455 - 2.0457)	2	1.506 - 1.509 (0.0593 - 0.0594)	STD 2	Green

CONNECTING ROD BEARING GRADE TABLE

Connecting rod bearing grade table : Refer to [EM-155. "Connecting Rod Bearing"](#).

UNDERSIZE BEARING USAGE GUIDE

- When the specified connecting rod bearing oil clearance is not obtained with standard size connecting rod bearings, use undersize (US) bearings.
- When using undersize (US) bearing, measure the connecting rod bearing inner diameter with bearing installed, and grind crankshaft pin so that the connecting rod bearing oil clearance satisfies the standard.

CAUTION:

In grinding crankshaft pin to use undersize bearings, keep the fillet R (A) [1.5 - 1.7 mm (0.059 - 0.067 in)].

Bearing undersize table : Refer to [EM-155. "Connecting Rod Bearing"](#).

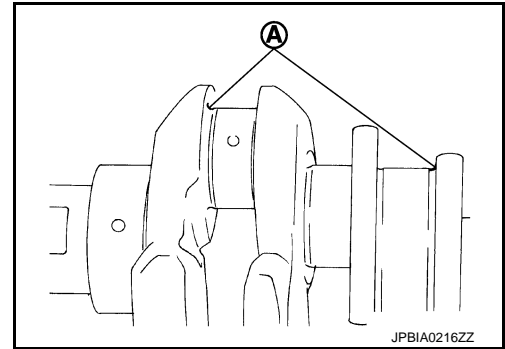

INFOID:000000006260661

Main Bearing

WHEN NEW CYLINDER BLOCK AND CRANKSHAFT ARE USED

1. "MAIN BEARING SELECTION TABLE" rows correspond to bearing housing grade on rear left side of cylinder block.

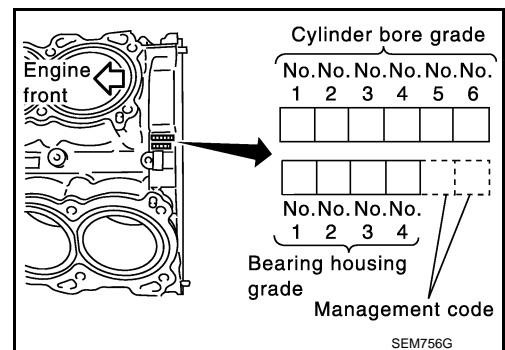

2. "MAIN BEARING SELECTION TABLE" columns correspond to journal diameter grade on front side of crankshaft.

- A : Journal diameter grade No. 1
- B : Journal diameter grade No. 2
- C : Journal diameter grade No. 3
- D : Journal diameter grade No. 4
- E : Pin diameter grade No. 1
- F : Pin diameter grade No. 2
- G : Pin diameter grade No. 3
- H : Pin diameter grade No. 4
- I : Pin diameter grade No. 5

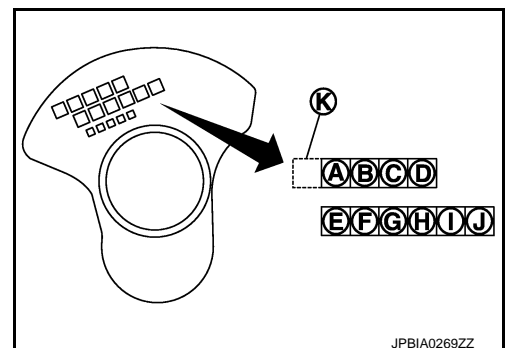

HOW TO SELECT PISTON AND BEARING

< UNIT DISASSEMBLY AND ASSEMBLY >

UNDERSIZE BEARING USAGE GUIDE

- When the specified main bearing oil clearance is not obtained with standard size main bearings, use under-size (US) bearing.
- When using under-size (US) bearing, measure the main bearing inner diameter with bearing installed, and grind main journal so that the main bearing oil clearance satisfies the standard.

CAUTION:

In grinding crankshaft main journal to use under-size bearings, keep the fillet R (A) [1.5 - 1.7 mm (0.059 - 0.067 in)].

Bearing undersize table : Refer to [EM-154](#), "[Main Bearing](#)".

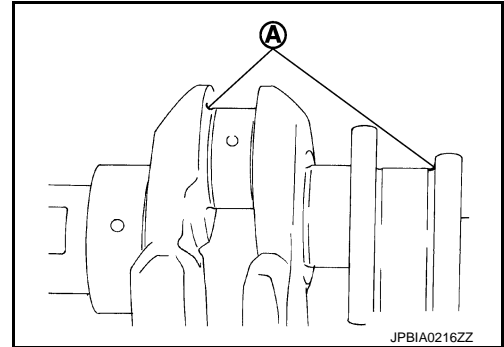

A

EM

C

D

E

F

G

H

I

J

K

L

M

N

O

P

SERVICE DATA AND SPECIFICATIONS (SDS)

< SERVICE DATA AND SPECIFICATIONS (SDS)

SERVICE DATA AND SPECIFICATIONS (SDS)

SERVICE DATA AND SPECIFICATIONS (SDS)

General Specification

INFOID:000000006260662

GENERAL SPECIFICATIONS

Cylinder arrangement		V-6
Displacement cm ³ (cu in)		3,498 (213.45)
Bore and stroke mm (in)		95.5 x 81.4 (3.760 x 3.205)
Valve arrangement		DOHC
Firing order		1-2-3-4-5-6
Number of piston rings	Compression	2
	Oil	1
Number of main bearings		4
Compression ratio		10.3
Compression pressure kPa (kg/cm ² , psi)/300 rpm	Standard	1,275 (13.0, 185)
	Minimum	981 (10.0, 142)
	Differential limit between cylinders	98 (1.0, 14)

Cylinder number

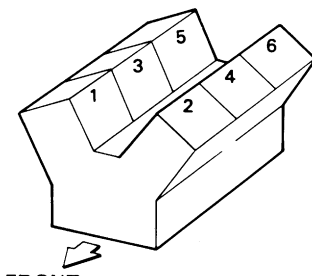

SEM713A

Valve timing
(Valve timing control - "OFF")

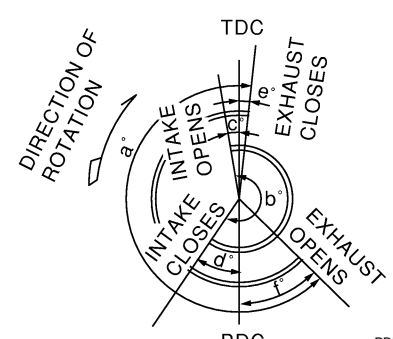

PBIC0187E

Unit: degree

a	b	c	d	e	f
240	240	-10	70	10	50

Drive Belt

INFOID:000000006260663

DRIVE BELT

Tension of drive belt	Belt tension is not necessary, as it is automatically adjusted by drive belt auto-tensioner.
-----------------------	--

SERVICE DATA AND SPECIFICATIONS (SDS)

< SERVICE DATA AND SPECIFICATIONS (SDS)

Spark Plug

INFOID:000000006260664

SPARK PLUG

Unit: mm (in)

Make	DENSO	
Standard type	FXE22HR11	
Gap	Standard	1.1 (0.043)
	Limit	1.4 (0.055)

Intake Manifold

INFOID:000000006260665

INTAKE MANIFOLD

Unit: mm (in)

Items		Limit
Surface distortion	Intake manifold	0.1 (0.004)

Exhaust Manifold

INFOID:000000006260666

EXHAUST MANIFOLD

Unit: mm (in)

Items		Limit
Surface distortion	Exhaust manifold	0.3 (0.012)

Camshaft

INFOID:000000006260667

CAMSHAFT

Unit: mm (in)

Items		Standard	Limit
Camshaft journal oil clearance	No. 1	0.045 - 0.086 (0.0018 - 0.0034)	0.15 (0.0059)
	No. 2, 3, 4	0.035 - 0.076 (0.0014 - 0.0030)	
Camshaft bracket inner diameter	No. 1	26.000 - 26.021 (1.0236 - 1.0244)	—
	No. 2, 3, 4	23.500 - 23.521 (0.9252 - 0.9260)	—
Camshaft journal diameter	No. 1	25.935 - 25.955 (1.0211 - 1.0218)	—
	No. 2, 3, 4	23.445 - 23.465 (0.9230 - 0.9238)	—
Camshaft end play		0.115 - 0.188 (0.0045 - 0.0074)	0.24 (0.0094)
Camshaft cam height "A"	Intake	45.465 - 45.655 (1.7900 - 1.7974)	0.2 (0.008)* ¹
	Exhaust	45.475 - 45.665 (1.7904 - 1.7978)	0.2 (0.008)* ¹
Camshaft runout [TIR* ²]		Less than 0.02 mm (0.0008)	0.05 (0.0020)
Camshaft sprocket runout [TIR* ²]		—	0.15 (0.0059)

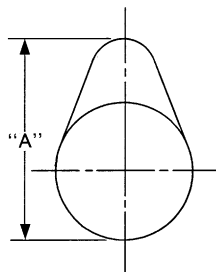

SEM671

SERVICE DATA AND SPECIFICATIONS (SDS)

< SERVICE DATA AND SPECIFICATIONS (SDS)

*1: Cam wear limit

*2: Total indicator reading

VALVE LIFTER

Unit: mm (in)

Items	Standard
Valve lifter outer diameter	33.980 - 33.990 (1.3378 - 1.3382)
Valve lifter hole diameter	34.000 - 34.016 (1.3386 - 1.3392)
Valve lifter clearance	0.010 - 0.036 (0.0004 - 0.0014)

VALVE CLEARANCE

Unit: mm (in)

Items	Cold	Hot* (reference data)
Intake	0.26 - 0.34 (0.010 - 0.013)	0.304 - 0.416 (0.012 - 0.016)
Exhaust	0.29 - 0.37 (0.011 - 0.015)	0.308 - 0.432 (0.012 - 0.017)

*: Approximately 80°C (176°F)

AVAILABLE VALVE LIFTER

Unit: mm (in)

Identification (stamped) mark	Thickness
788	7.88 (0.3102)
790	7.90 (0.3110)
792	7.92 (0.3118)
794	7.94 (0.3126)
796	7.96 (0.3134)
798	7.98 (0.3142)
800	8.00 (0.3150)
802	8.02 (0.3157)
804	8.04 (0.3165)
806	8.06 (0.3173)
808	8.08 (0.3181)
810	8.10 (0.3189)
812	8.12 (0.3197)
814	8.14 (0.3205)
816	8.16 (0.3213)
818	8.18 (0.3220)
820	8.20 (0.3228)
822	8.22 (0.3236)
824	8.24 (0.3244)
826	8.26 (0.3252)
828	8.28 (0.3260)
830	8.30 (0.3268)
832	8.32 (0.3276)
834	8.34 (0.3283)
836	8.36 (0.3291)
838	8.38 (0.3299)

SERVICE DATA AND SPECIFICATIONS (SDS)

< SERVICE DATA AND SPECIFICATIONS (SDS)

Identification (stamped) mark	Thickness
840	8.40 (0.3307)

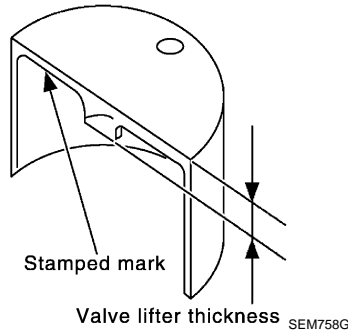

Cylinder Head

INFOID:000000006260668

CYLINDER HEAD

Unit: mm (in)

Items	Standard	Limit
Head surface distortion	Less than 0.03 (0.0012)	0.1 (0.004)
Normal cylinder head height "H"	126.3 - 126.5 (4.97 - 4.98)	—

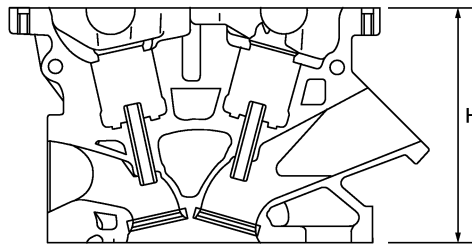

PBIC0924E

VALVE DIMENSIONS

Unit: mm (in)

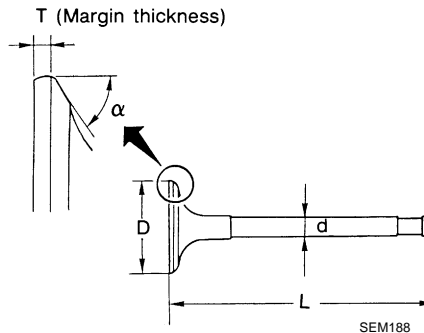

Valve head diameter "D"	Intake	36.6 - 36.9 (1.441 - 1.453)
	Exhaust	30.2 - 30.5 (1.189 - 1.201)
Valve length "L"	Intake	97.13 (3.8240)
	Exhaust	94.67 (3.7272)
Valve stem diameter "d"	Intake	5.965 - 5.980 (0.2348 - 0.2354)
	Exhaust	5.962 - 5.970 (0.2347 - 0.2350)

SERVICE DATA AND SPECIFICATIONS (SDS)

< SERVICE DATA AND SPECIFICATIONS (SDS)

Valve seat angle "α"	Intake	45°15' - 45°45'
	Exhaust	
Valve margin "T"	Intake	1.1 (0.043)
	Exhaust	1.3 (0.051)
Valve margin "T" limit		0.5 (0.020)
Valve stem end surface grinding limit		0.2 (0.008)

VALVE GUIDE

Unit: mm (in)

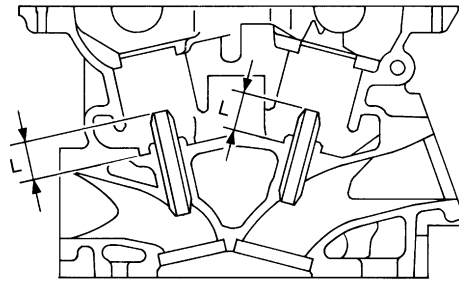

SEM950E

Items		Standard	Oversize (Service) [0.2 (0.008)]
Valve guide	Outer diameter	10.023 - 10.034 (0.3946 - 0.3950)	10.223 - 10.234 (0.4025 - 0.4029)
	Inner diameter (Finished size)	6.000 - 6.018 (0.2362 - 0.2369)	
Cylinder head valve guide hole diameter		9.975 - 9.996 (0.3927 - 0.3935)	10.175 - 10.196 (0.4006 - 0.4014)
Interference fit of valve guide		0.027 - 0.059 (0.0011 - 0.0023)	
Items		Standard	Limit
Valve guide clearance	Intake	0.020 - 0.053 (0.0008 - 0.0021)	0.08 (0.0031)
	Exhaust	0.030 - 0.056 (0.0012 - 0.0022)	0.09 (0.0035)
Projection length "L"		12.6 - 12.8 (0.496 - 0.504)	

VALVE SEAT

Unit: mm (in)

Items	Standard	Oversize (Service) [0.5 (0.02)]
-------	----------	---------------------------------

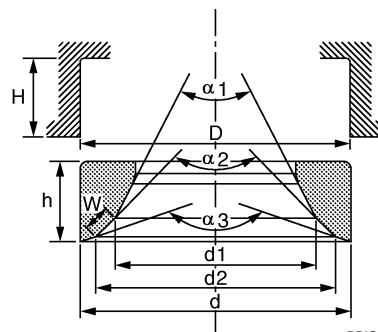

PBIC2745E

Cylinder head seat recess diameter "D"	Intake	38.000 - 38.016 (1.4961 - 1.4967)	38.500 - 38.516 (1.5157 - 1.5164)
	Exhaust	31.600 - 31.616 (1.2441 - 1.2447)	32.100 - 32.116 (1.2638 - 1.2644)
Valve seat outer diameter "d"	Intake	38.097 - 38.113 (1.4999 - 1.5005)	38.597 - 38.613 (1.5196 - 1.5202)
	Exhaust	31.680 - 31.696 (1.2472 - 1.2479)	32.180 - 32.196 (1.2669 - 1.2676)
Valve seat interference fit	Intake	0.081 - 0.113 (0.0032 - 0.0044)	
	Exhaust	0.064 - 0.096 (0.0025 - 0.0038)	

SERVICE DATA AND SPECIFICATIONS (SDS)

< SERVICE DATA AND SPECIFICATIONS (SDS)

Items		Standard	Oversize (Service) [0.5 (0.02)]
Diameter "d1"*1	Intake	34.6 (1.362)	
	Exhaust	27.7 (1.091)	
Diameter "d2"*2	Intake	35.9 - 36.4 (1.413 - 1.433)	
	Exhaust	29.3 - 29.8 (1.154 - 1.173)	
Angle "α1"	Intake	60°	
	Exhaust	60°	
Angle "α2"	Intake	88°45' - 90°15'	
	Exhaust	88°45' - 90°15'	
Angle "α3"	Intake	120°	
	Exhaust	120°	
Contacting width "W"*3	Intake	1.0 - 1.4 (0.039 - 0.055)	
	Exhaust	1.2 - 1.6 (0.047 - 0.063)	
Height "h"	Intake	5.9 - 6.0 (0.232 - 0.236)	5.0 - 5.1 (0.197 - 0.201)
	Exhaust	5.9 - 6.0 (0.232 - 0.236)	4.9 - 5.0 (0.193 - 0.197)
Depth "H"	6.0 (0.236)		

*1: Diameter made by intersection point of conic angles "α1" and "α2"

*2: Diameter made by intersection point of conic angles "α2" and "α3"

*3: Machining data

VALVE SPRING

Items	Standard
Free height	47.07 mm (1.8531 in)
Installation height	37.00 mm (1.4567 in)
Installation load	166 - 188 N (16.9 - 19.2 kg, 37 - 42 lb)
Height during valve open	27.20 mm (1.0709 in)
Load with valve open	373 - 421 N (38.0 - 42.9 kg, 84 - 95 lb)

Unit: mm (in)

Items	Limit
Squareness	2.1 (0.083)

Cylinder Block

INFOID:0000000006260669

CYLINDER BLOCK

Unit: mm (in)

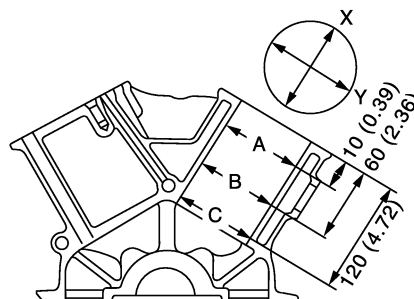

JPBIA2238GB

SERVICE DATA AND SPECIFICATIONS (SDS)

< SERVICE DATA AND SPECIFICATIONS (SDS)

Surface flatness		Standard		Less than 0.03 (0.0012)
		Limit		0.1 (0.004)
Main bearing housing inner diameter		Standard		63.993 - 64.017 (2.5194 - 2.5203)
Cylinder bore	Inner diameter	Standard	Grade No. 1	95.500 - 95.510 (3.7598 - 3.7602)
			Grade No. 2	95.510 - 95.520 (3.7602 - 3.7606)
			Grade No. 3	95.520 - 95.530 (3.7606 - 3.7610)
		Wear limit		0.2 (0.008)
Out-of-round		Limit		0.015 (0.0006)
Taper				0.010 (0.0004)
Main bearing housing inner diameter grade (Without bearing)		Grade No. A		63.993 - 63.994 (2.5194 - 2.5194)
		Grade No. B		63.994 - 63.995 (2.5194 - 2.5195)
		Grade No. C		63.995 - 63.996 (2.5195 - 2.5195)
		Grade No. D		63.996 - 63.997 (2.5195 - 2.5196)
		Grade No. E		63.997 - 63.998 (2.5196 - 2.5196)
		Grade No. F		63.998 - 63.999 (2.5196 - 2.5196)
		Grade No. G		63.999 - 64.000 (2.5196 - 2.5197)
		Grade No. H		64.000 - 64.001 (2.5197 - 2.5197)
		Grade No. J		64.001 - 64.002 (2.5197 - 2.5198)
		Grade No. K		64.002 - 64.003 (2.5198 - 2.5198)
		Grade No. L		64.003 - 64.004 (2.5198 - 2.5198)
		Grade No. M		64.004 - 64.005 (2.5198 - 2.5199)
		Grade No. N		64.005 - 64.006 (2.5199 - 2.5199)
		Grade No. P		64.006 - 64.007 (2.5199 - 2.5200)
		Grade No. R		64.007 - 64.008 (2.5200 - 2.5200)
		Grade No. S		64.008 - 64.009 (2.5200 - 2.5200)
		Grade No. T		64.009 - 64.010 (2.5200 - 2.5201)
Grade No. U		64.010 - 64.011 (2.5201 - 2.5201)		
Grade No. V		64.011 - 64.012 (2.5201 - 2.5202)		
Grade No. W		64.012 - 64.013 (2.5202 - 2.5202)		
Grade No. X		64.013 - 64.014 (2.5202 - 2.5202)		
Grade No. Y		64.014 - 64.015 (2.5202 - 2.5203)		
Grade No. 4		64.015 - 64.016 (2.5203 - 2.5203)		
Grade No. 7		64.016 - 64.017 (2.5203 - 2.5203)		
Difference in inner diameter between cylinders		Standard		Less than 0.03 (0.0012)

AVAILABLE PISTON

Unit: mm (in)

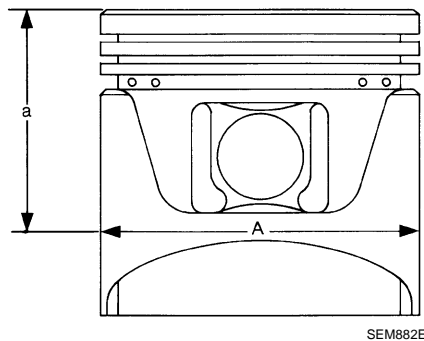

Items		Standard	Oversize (Service) [0.2 (0.008)]
Piston skirt diameter "A"	Grade No. 1	95.480 - 95.490 (3.7590 - 3.7594)	—
	Grade No. 2	95.490 - 95.500 (3.7594 - 3.7598)	—
	Grade No. 3	95.500 - 95.510 (3.7598 - 3.7602)	—
	Service	—	95.680 - 95.710 (3.7669 - 3.7681)
Items		Standard	Limit
"a" dimension		38.0 (1.496)	—

SERVICE DATA AND SPECIFICATIONS (SDS)

< SERVICE DATA AND SPECIFICATIONS (SDS)

Piston pin hole diameter	Grade No. 0	21.993 - 21.999 (0.8659 - 0.8661)	—
	Grade No. 1	21.999 - 22.005 (0.8661 - 0.8663)	—
Piston to cylinder bore clearance		0.010 - 0.030 (0.0004 - 0.0012)	0.08 (0.0031)

PISTON RING

Unit: mm (in)

Items		Standard	Limit
Side clearance	Top	0.045 - 0.080 (0.0018 - 0.0031)	0.11 (0.0043)
	2nd	0.030 - 0.070 (0.0012 - 0.0028)	0.10 (0.0039)
	Oil ring	0.065 - 0.125 (0.0026 - 0.0049)	—
End gap	Top	0.23 - 0.33 (0.0091 - 0.0130)	0.54 (0.0213)
	2nd	0.23 - 0.33 (0.0091 - 0.0130)	0.80 (0.0315)
	Oil (rail ring)	0.20 - 0.45 (0.0079 - 0.0177)	0.95 (0.0374)

PISTON PIN

Unit: mm (in)

Items		Standard	Limit
Piston pin outer diameter	Grade No. 0	21.989 - 21.995 (0.8657 - 0.8659)	—
	Grade No. 1	21.995 - 22.001 (0.8659 - 0.8662)	—
Piston to piston pin oil clearance		0.002 - 0.006 (0.0001 - 0.0002)	—
Connecting rod bushing oil clearance		0.005 - 0.017 (0.0002 - 0.0007)	0.030 (0.0012)

CONNECTING ROD

Unit: mm (in)

Items		Standard	Limit
Center distance		144.15 - 144.25 (5.68 - 5.68)	—
Bend [per 100 (3.94)]		—	0.15 (0.0059)
Torsion [per 100 (3.94)]		—	0.30 (0.0118)
Connecting rod bushing inner diameter*	Grade No. 0	22.000 - 22.006 (0.8661 - 0.8664)	—
	Grade No. 1	22.006 - 22.012 (0.8664 - 0.8666)	—
Connecting rod big end diameter (Without bearing)		55.000 - 55.013 (2.1654 - 2.1659)	—
Side clearance		0.20 - 0.35 (0.0079 - 0.0138)	0.40 (0.0157)

*: After installing in connecting rod

CRANKSHAFT

SERVICE DATA AND SPECIFICATIONS (SDS)

< SERVICE DATA AND SPECIFICATIONS (SDS)

Unit: mm (in)

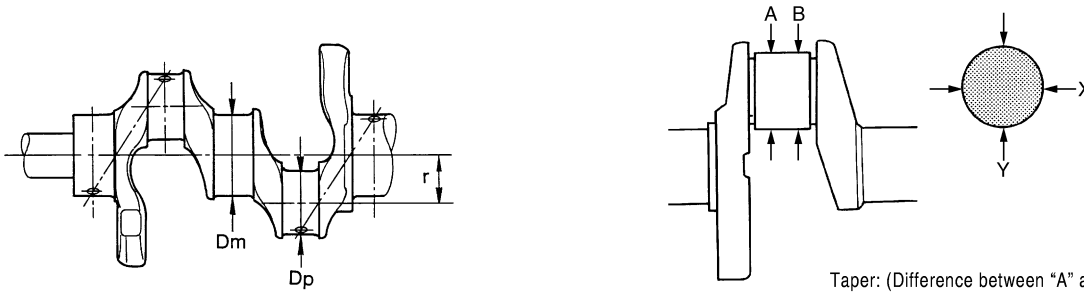

SEM645

SBIA0535E

Main journal diameter. "Dm" grade	Standard	Grade No. A	59.975 - 59.974 (2.3612 - 2.3612)
		Grade No. B	59.974 - 59.973 (2.3612 - 2.3611)
		Grade No. C	59.973 - 59.972 (2.3611 - 2.3611)
		Grade No. D	59.972 - 59.971 (2.3611 - 2.3611)
		Grade No. E	59.971 - 59.970 (2.3611 - 2.3610)
		Grade No. F	59.970 - 59.969 (2.3610 - 2.3610)
		Grade No. G	59.969 - 59.968 (2.3610 - 2.3609)
		Grade No. H	59.968 - 59.967 (2.3609 - 2.3609)
		Grade No. J	59.967 - 59.966 (2.3609 - 2.3609)
		Grade No. K	59.966 - 59.965 (2.3609 - 2.3608)
		Grade No. L	59.965 - 59.964 (2.3608 - 2.3608)
		Grade No. M	59.964 - 59.963 (2.3608 - 2.3607)
		Grade No. N	59.963 - 59.962 (2.3607 - 2.3607)
		Grade No. P	59.962 - 59.961 (2.3607 - 2.3607)
		Grade No. R	59.961 - 59.960 (2.3607 - 2.3606)
		Grade No. S	59.960 - 59.959 (2.3606 - 2.3606)
		Grade No. T	59.959 - 59.958 (2.3606 - 2.3605)
		Grade No. U	59.958 - 59.957 (2.3605 - 2.3605)
		Grade No. V	59.957 - 59.956 (2.3605 - 2.3605)
		Grade No. W	59.956 - 59.955 (2.3605 - 2.3604)
Grade No. X	59.955 - 59.954 (2.3604 - 2.3604)		
Grade No. Y	59.954 - 59.953 (2.3604 - 2.3603)		
Grade No. 4	59.953 - 59.952 (2.3603 - 2.3603)		
Grade No. 7	59.952 - 59.951 (2.3603 - 2.3603)		
Pin journal diameter. "Dp" grade	Standard	Grade No. 0	51.968 - 51.974 (2.0460 - 2.0462)
		Grade No. 1	51.962 - 51.968 (2.0457 - 2.0460)
		Grade No. 2	51.956 - 51.962 (2.0445 - 2.0457)
Center distance "r"			40.66 - 40.74 (1.6008 - 1.6039)
Taper (Difference between "A" and "B")	Limit		0.002 (0.0001)
Out-of-round (Difference between "X" and "Y")			0.002 (0.0001)
Crankshaft runout [TIR*]	Standard		Less than 0.05 (0.0020)
	Limit		0.10 (0.0039)
Crankshaft end play	Standard		0.10 - 0.25 (0.0039 - 0.0098)
	Limit		0.30 (0.0118)

*: Total indicator reading

Main Bearing

INFOID:000000006260670

MAIN BEARING

SERVICE DATA AND SPECIFICATIONS (SDS)

< SERVICE DATA AND SPECIFICATIONS (SDS)

Unit: mm (in)

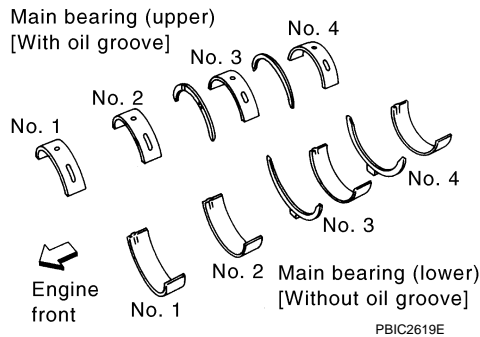

Grade number		Thickness	Width	Identification color	Remarks
0		2.000 - 2.003 (0.0787 - 0.0789)	19.9 - 20.1 (0.783 - 0.791)	Black	Grade is the same for upper and lower bearings.
1		2.003 - 2.006 (0.0789 - 0.0790)		Brown	
2		2.006 - 2.009 (0.0790 - 0.0791)		Green	
3		2.009 - 2.012 (0.0791 - 0.0792)		Yellow	
4		2.012 - 2.015 (0.0792 - 0.0793)		Blue	
5		2.015 - 2.018 (0.0793 - 0.0794)		Pink	
6		2.018 - 2.021 (0.0794 - 0.0796)		Purple	
7		2.021 - 2.024 (0.0796 - 0.0797)		White	Grade and color are different for upper and lower bearings.
01	UPR	2.003 - 2.006 (0.0789 - 0.0790)		Brown	
	LWR	2.000 - 2.003 (0.0787 - 0.0789)		Black	
12	UPR	2.006 - 2.009 (0.0790 - 0.0791)		Green	
	LWR	2.003 - 2.006 (0.0789 - 0.0790)		Brown	
23	UPR	2.009 - 2.012 (0.0791 - 0.0792)		Yellow	
	LWR	2.006 - 2.009 (0.0790 - 0.0791)		Green	
34	UPR	2.012 - 2.015 (0.0792 - 0.0793)	Blue		
	LWR	2.009 - 2.012 (0.0791 - 0.0792)	Yellow		
45	UPR	2.015 - 2.018 (0.0793 - 0.0794)	Pink		
	LWR	2.012 - 2.015 (0.0792 - 0.0793)	Blue		
56	UPR	2.018 - 2.021 (0.0794 - 0.0796)	Purple		
	LWR	2.015 - 2.018 (0.0793 - 0.0794)	Pink		
67	UPR	2.021 - 2.024 (0.0796 - 0.0797)	White		
	LWR	2.018 - 2.021 (0.0794 - 0.0796)	Purple		

UNDERSIZE

Unit: mm (in)

Items	Thickness	Main journal diameter
0.25 (0.0098)	2.132 - 2.140 (0.0839 - 0.0843)	Grind so that bearing clearance is the specified value.

MAIN BEARING OIL CLEARANCE

Unit: mm (in)

Items	Standard	Limit
Main bearing oil clearance	0.035 - 0.045 (0.0014 - 0.0018)*	0.065 (0.0026)

*: Actual clearance

Connecting Rod Bearing

INFOID:000000006260671

CONNECTING ROD BEARING

SERVICE DATA AND SPECIFICATIONS (SDS)

< SERVICE DATA AND SPECIFICATIONS (SDS)

Unit: mm (in)

Grade number	Thickness	Identification color (mark)
0	1.500 - 1.503 (0.0591 - 0.0592)	Black
1	1.503 - 1.506 (0.0592 - 0.0593)	Brown
2	1.506 - 1.509 (0.0593 - 0.0594)	Green

UNDERSIZE

Unit: mm (in)

Items	Thickness	Crank pin journal diameter
0.25 (0.0098)	1.626 - 1.634 (0.0640 - 0.0643)	Grind so that bearing clearance is the specified value.

CONNECTING ROD BEARING OIL CLEARANCE

Unit: mm (in)

Items	Standard	Limit
Connecting rod bearing oil clearance	0.020 - 0.045 (0.0008 - 0.0018)*	0.070 (0.0028)

*: Actual clearance