

# MWI

## SECTION

# METER, WARNING LAMP & INDICATOR

A  
B  
C  
D  
E  
F  
G  
H  
I  
J  
K  
L  
M  
O  
P

## CONTENTS

<b>BASIC INSPECTION</b> .....	4	<b>ODO/TRIP METER</b> .....	18
<b>DIAGNOSIS AND REPAIR WORKFLOW</b> .....	4	ODO/TRIP METER : System Diagram .....	18
Work flow .....	4	ODO/TRIP METER : System Description .....	18
<b>SYSTEM DESCRIPTION</b> .....	6	ODO/TRIP METER : Component Parts Location .....	19
<b>METER SYSTEM</b> .....	6	ODO/TRIP METER : Component Description .....	20
<b>METER SYSTEM</b> .....	6	<b>SHIFT POSITION INDICATOR</b> .....	20
METER SYSTEM : System Diagram .....	6	SHIFT POSITION INDICATOR : System Diagram .....	20
METER SYSTEM : System Description .....	6	SHIFT POSITION INDICATOR : System Description .....	20
METER SYSTEM : Component Parts Location .....	9	SHIFT POSITION INDICATOR : Component Parts Location .....	21
METER SYSTEM : Component Description .....	10	SHIFT POSITION INDICATOR : Component Description .....	22
<b>SPEEDOMETER</b> .....	10	<b>WARNING LAMPS/INDICATOR LAMPS</b> .....	22
SPEEDOMETER : System Diagram .....	10	WARNING LAMPS/INDICATOR LAMPS : System Diagram .....	22
SPEEDOMETER : System Description .....	10	WARNING LAMPS/INDICATOR LAMPS : System Description .....	22
SPEEDOMETER : Component Parts Location .....	11	WARNING LAMPS/INDICATOR LAMPS : Component Parts Location .....	23
SPEEDOMETER : Component Description .....	12	WARNING LAMPS/INDICATOR LAMPS : Component Description .....	24
<b>TACHOMETER</b> .....	12	<b>METER ILLUMINATION CONTROL</b> .....	24
TACHOMETER : System Diagram .....	12	METER ILLUMINATION CONTROL : System Diagram .....	24
TACHOMETER : System Description .....	12	METER ILLUMINATION CONTROL : System Description .....	24
TACHOMETER : Component Parts Location .....	13	METER ILLUMINATION CONTROL : Component Parts Location .....	25
TACHOMETER : Component Description .....	14	METER ILLUMINATION CONTROL : Component Description .....	26
<b>ENGINE COOLANT TEMPERATURE GAUGE</b> .....	14	<b>INFORMATION DISPLAY</b> .....	26
ENGINE COOLANT TEMPERATURE GAUGE : System Diagram .....	14	INFORMATION DISPLAY : System Diagram .....	26
ENGINE COOLANT TEMPERATURE GAUGE : System Description .....	14	INFORMATION DISPLAY : System Description .....	26
ENGINE COOLANT TEMPERATURE GAUGE : Component Parts Location .....	15	INFORMATION DISPLAY : Component Parts Location .....	30
ENGINE COOLANT TEMPERATURE GAUGE : Component Description .....	16	INFORMATION DISPLAY : Component Description .....	31
<b>FUEL GAUGE</b> .....	16		
FUEL GAUGE : System Diagram .....	16		
FUEL GAUGE : System Description .....	16		
FUEL GAUGE : Component Parts Location .....	17		
FUEL GAUGE : Component Description .....	18		

MWI

<b>COMPASS</b> .....	<b>32</b>	Component Function Check .....	52
Description .....	32	Diagnosis Procedure .....	52
Component Parts Location .....	33	Component Inspection .....	52
Special Repair Requirement .....	33		
<b>DIAGNOSIS SYSTEM (METER)</b> .....	<b>34</b>	<b>PARKING BRAKE SWITCH SIGNAL CIR-</b>	
Diagnosis Description .....	34	<b>CUIT</b> .....	<b>54</b>
CONSULT-III Function (METER/M&A) .....	35	Description .....	54
		Diagnosis Procedure .....	54
		Component Inspection .....	54
<b>DTC/CIRCUIT DIAGNOSIS</b> .....	<b>39</b>	<b>WASHER LEVEL SWITCH SIGNAL CIRCUIT..</b>	<b>55</b>
<b>U1000 CAN COMM CIRCUIT</b> .....	<b>39</b>	Description .....	55
Description .....	39	Diagnosis Procedure .....	55
DTC Logic .....	39	Component Inspection .....	55
Diagnosis Procedure .....	39		
<b>U1010 CONTROL UNIT (CAN)</b> .....	<b>40</b>	<b>A/C AUTO AMP. CONNECTION RECOGNI-</b>	
Description .....	40	<b>TION SIGNAL CIRCUIT</b> .....	<b>56</b>
DTC Logic .....	40	Description .....	56
Diagnosis Procedure .....	40	Diagnosis Procedure .....	56
<b>B2205 VEHICLE SPEED</b> .....	<b>41</b>		
Description .....	41	<b>COMPASS</b> .....	<b>57</b>
DTC Logic .....	41	Wiring Diagram - COMPASS - .....	57
Diagnosis Procedure .....	41		
<b>B2267 ENGINE SPEED</b> .....	<b>42</b>	<b>ECU DIAGNOSIS INFORMATION</b> .....	<b>59</b>
Description .....	42		
DTC Logic .....	42	<b>COMBINATION METER</b> .....	<b>59</b>
Diagnosis Procedure .....	42	Reference Value .....	59
		Wiring Diagram - METER - .....	65
<b>B2268 WATER TEMP</b> .....	<b>43</b>	Fail-Safe .....	76
Description .....	43	DTC Index .....	77
DTC Logic .....	43	<b>IPDM E/R (INTELLIGENT POWER DISTRI-</b>	
Diagnosis Procedure .....	43	<b>BUTION MODULE ENGINE ROOM)</b> .....	<b>79</b>
<b>POWER SUPPLY AND GROUND CIRCUIT</b> ....	<b>44</b>	Reference Value .....	79
		Wiring Diagram - IPDM E/R - .....	87
<b>COMBINATION METER</b> .....	<b>44</b>	Fail-safe .....	90
COMBINATION METER : Diagnosis Procedure ...	44	DTC Index .....	92
<b>IPDM E/R (INTELLIGENT POWER DISTRI-</b>		<b>SYMPTOM DIAGNOSIS</b> .....	<b>93</b>
<b>BUTION MODULE ENGINE ROOM)</b> .....	<b>44</b>		
IPDM E/R (INTELLIGENT POWER DISTRI-		<b>THE FUEL GAUGE POINTER DOES NOT</b>	
<b>BUTION MODULE ENGINE ROOM) : Diagnosis Pro-</b>		<b>MOVE</b> .....	<b>93</b>
<b>cedure</b> .....	<b>44</b>	Description .....	93
<b>FUEL LEVEL SENSOR SIGNAL CIRCUIT</b> ....	<b>46</b>	Diagnosis Procedure .....	93
Description .....	46	<b>THE METER CONTROL SWITCH IS INOPER-</b>	
Component Function Check .....	46	<b>ATIVE</b> .....	<b>94</b>
Diagnosis Procedure .....	46	Description .....	94
Component Inspection .....	47	Diagnosis Procedure .....	94
<b>METER CONTROL SWITCH SIGNAL CIR-</b>		<b>THE OIL PRESSURE WARNING LAMP</b>	
<b>CUIT</b> .....	<b>49</b>	<b>DOES NOT TURN ON</b> .....	<b>95</b>
Description .....	49	Description .....	95
Diagnosis Procedure .....	49	Diagnosis Procedure .....	95
Component Inspection .....	50	<b>THE OIL PRESSURE WARNING LAMP</b>	
<b>OIL PRESSURE SWITCH SIGNAL CIRCUIT</b> ...	<b>52</b>	<b>DOES NOT TURN OFF</b> .....	<b>96</b>
Description .....	52	Description .....	96
		Diagnosis Procedure .....	96

<b>THE PARKING BRAKE RELEASE WARNING CONTINUES DISPLAYING, OR DOES NOT DISPLAY</b> .....	<b>97</b>	<b>PRECAUTIONS</b> .....	<b>102</b>	
Description .....	97	<b>FOR USA AND CANADA</b> .....	<b>102</b>	A
Diagnosis Procedure .....	97	FOR USA AND CANADA : Precaution for Supplemental Restraint System (SRS) "AIR BAG" and "SEAT BELT PRE-TENSIONER" .....	102	B
<b>THE LOW WASHER FLUID WARNING CONTINUES DISPLAYING, or DOES NOT DISPLAY</b> .....	<b>98</b>	<b>FOR MEXICO</b> .....	<b>102</b>	C
Description .....	98	FOR MEXICO : Precaution for Supplemental Restraint System (SRS) "AIR BAG" and "SEAT BELT PRE-TENSIONER" .....	102	
Diagnosis Procedure .....	98	<b>PREPARATION</b> .....	<b>104</b>	D
<b>THE DOOR OPEN WARNING CONTINUES DISPLAYING, OR DOES NOT DISPLAY</b> .....	<b>99</b>	<b>PREPARATION</b> .....	<b>104</b>	E
Description .....	99	Commercial Service Tools .....	104	
Diagnosis Procedure .....	99	<b>REMOVAL AND INSTALLATION</b> .....	<b>105</b>	F
<b>THE AMBIENT TEMPERATURE DISPLAY IS INCORRECT</b> .....	<b>100</b>	<b>COMBINATION METER</b> .....	<b>105</b>	G
Description .....	100	Exploded View .....	105	
Diagnosis Procedure .....	100	Removal and Installation .....	105	
<b>NORMAL OPERATING CONDITION</b> .....	<b>101</b>	Disassembly and Assembly .....	105	H
<b>COMPASS</b> .....	<b>101</b>	<b>METER CONTROL SWITCH</b> .....	<b>106</b>	I
COMPASS : Description .....	101	Exploded View .....	106	
<b>INFORMATION DISPLAY</b> .....	<b>101</b>	Removal and Installation .....	106	J
INFORMATION DISPLAY : Description .....	101	<b>COMPASS</b> .....	<b>107</b>	K
<b>PRECAUTION</b> .....	<b>102</b>	Exploded View .....	107	L
		Removal and Installation .....	107	M

# DIAGNOSIS AND REPAIR WORKFLOW

< BASIC INSPECTION >

## BASIC INSPECTION

### DIAGNOSIS AND REPAIR WORKFLOW

Work flow

INFOID:000000006262101

#### OVERALL SEQUENCE

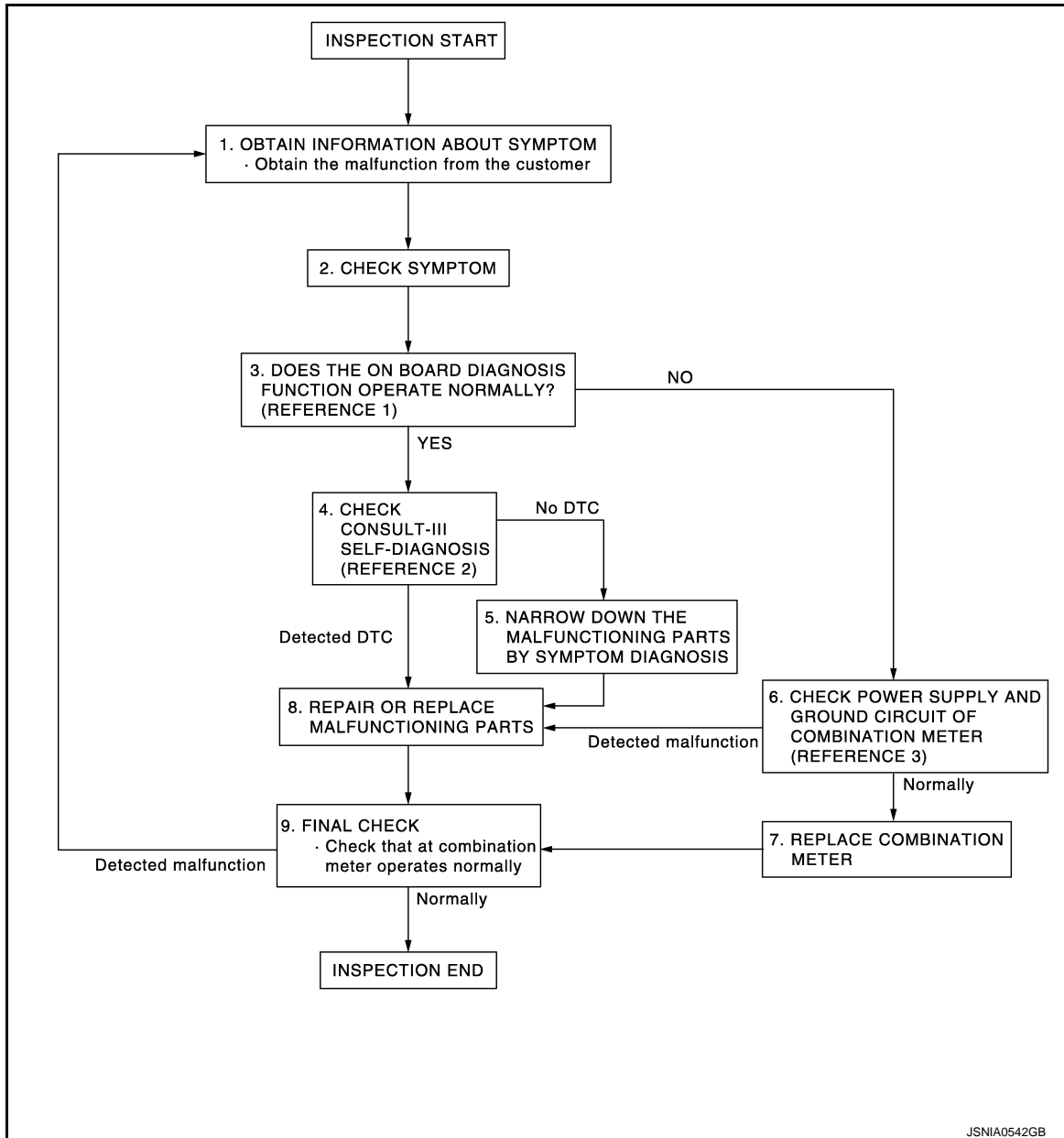

- Reference 1...[MWI-34, "Diagnosis Description"](#).
- Reference 2...[MWI-77, "DTC Index"](#).
- Reference 3...[MWI-44, "COMBINATION METER : Diagnosis Procedure"](#).

#### DETAILED FLOW

##### 1.OBTAIN INFORMATION ABOUT SYMPTOM

Interview the customer to obtain as much information as possible about the conditions and environment under which the malfunction occurred.

>> GO TO 2.

##### 2.CHECK SYMPTOM

# DIAGNOSIS AND REPAIR WORKFLOW

## < BASIC INSPECTION >

- Check the symptom based on the information obtained from the customer.
- Check that any other malfunctions are present.

>> GO TO 3.

## 3.CHECK ON BOARD DIAGNOSIS OPERATION

Check that the on board diagnosis function operates. Refer to [MWI-34, "Diagnosis Description"](#).

Does the on board diagnosis function operate normally?

YES >> GO TO 4.

NO >> GO TO 6.

## 4.CHECK CONSULT-III SELF-DIAGNOSIS RESULTS

Connect CONSULT-III and perform self-diagnosis. Refer to [MWI-35, "CONSULT-III Function \(METER/M&A\)"](#).

Are self-diagnosis results normal?

YES >> GO TO 5.

NO >> GO TO 8.

## 5.NARROW DOWN THE MALFUNCTIONING PARTS BY SYMPTOM DIAGNOSIS

Perform symptom diagnosis and narrow down the malfunctioning parts.

>> GO TO 8.

## 6.CHECK COMBINATION METER POWER SUPPLY AND GROUND CIRCUITS

Inspect combination meter power supply and ground circuits. Refer to [MWI-44, "COMBINATION METER : Diagnosis Procedure"](#).

Is inspection result OK?

YES >> GO TO 7.

NO >> GO TO 8.

## 7.REPLACE COMBINATION METER

Replace combination meter.

>> GO TO 9.

## 8.REPAIR OR REPLACE MALFUNCTIONING PARTS

Repair or replace the malfunctioning parts.

### **NOTE:**

If DTC is displayed, erase DTC after repair or replace malfunctioning parts.

>> GO TO 9.

## 9.FINAL CHECK

Check that the combination meter operates normally.

Do they operate normally?

YES >> INSPECTION END

NO >> GO TO 1.

A

B

C

D

E

F

G

H

I

J

K

L

M

MWI

O

P

# METER SYSTEM

< SYSTEM DESCRIPTION >

## SYSTEM DESCRIPTION

### METER SYSTEM

### METER SYSTEM

### METER SYSTEM : System Diagram

INFOID:000000006262102

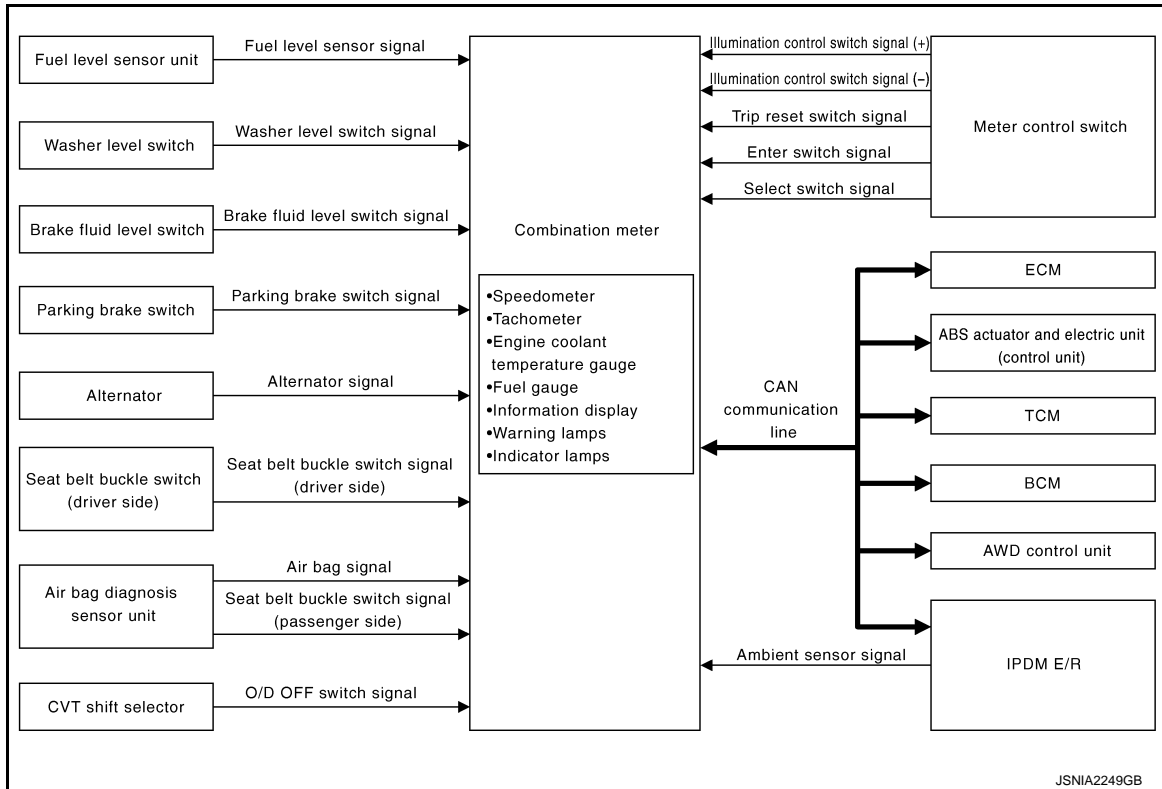

### METER SYSTEM : System Description

INFOID:000000006262103

#### COMBINATION METER

- The combination meter receives the information required to control the operation of each gauge, indicator/warning lamp, and information display via CAN communication from each unit, each switch, and sensor.
- The combination meter incorporates a trip computer that displays warnings and messages on the information display according to the information received from various units.
- The combination meter incorporates a buzzer function that sounds an audible alarm with the integrated buzzer device. Refer to [WCS-5. "WARNING CHIME SYSTEM : System Description"](#) for further details.
- The combination meter integrates the meter circuit check function and the segment check function that checks the information display operation.

#### IPDM E/R

- IPDM E/R reads the ON/OFF signals of the oil pressure switch and transmits the oil pressure switch signal to the combination meter via BCM with the CAN communication line.
- IPDM E/R is equipped with the diagnosis function. It can perform the operation check of oil pressure warning lamp with the auto active test and the diagnosis with CONSULT-III.

#### METER CONTROL FUNCTION LIST

# METER SYSTEM

## < SYSTEM DESCRIPTION >

System		Description	Signal source	
Meter/gauge	Speedometer	Receives vehicle speed signal and indicates vehicle speed.	ABS actuator and electric unit (control unit)	A
	Tachometer	Receives engine speed signal and indicates engine speed.	ECM	B
	Fuel gauge	Receives fuel level sensor signal and indicates fuel level.	Fuel level sensor unit	
	Engine coolant temperature gauge	Receives engine coolant temperature signal and indicates coolant temperature.	ECM	C
Warning lamp/indicator lamp	Oil pressure warning lamp	Receives oil pressure warning lamp signal and illuminates warning lamp.	IPDM E/R	
	Master warning	Illuminates according to warning output on information display.	—	D
Information display	Door open warning	Receives door switch signals and displays warning.	BCM	
	Parking brake release warning	Receives parking brake switch signal and vehicle speed signal and displays warnings.	Parking brake switch	E
			ABS actuator and electric unit (control unit)	
	Low fuel warning	Receives fuel gauge signal and displays warning if fuel level decreases to 11 ℓ (2-7/8 US gal, 2-3/8 Imp gal) or less.	Fuel level sensor unit	F
	Low washer fluid warning	Receives washer level switch signal and displays warning.	Washer level switch	
	Low outside temperature warning	Monitors ambient sensor signal and displays warning if ambient temperature decreases to 3°C (37°F) or less. (If enabled)	Ambient sensor	G
	Low tire pressure warning	Receives TPMS display signals and displays warning.	BCM	H
	Fuel filler cap warning	Receives fuel filler cap warning display signals and displays warning.	ECM	
	Instantaneous fuel consumption	Calculates instantaneous fuel consumption based on received vehicle speed signals and fuel consumption monitor signal and displays it.	ECM	I
			ABS actuator and electric unit (control unit)	J
	Average fuel consumption	Calculates average fuel consumption in a reset-to-reset interval based on received vehicle speed signals and fuel consumption monitor signal and displays it.	ECM	
			ABS actuator and electric unit (control unit)	K
	Average vehicle speed	Calculates average vehicle speed in a reset-to-reset interval based on received vehicle speed signals and displays it.	ABS actuator and electric unit (control unit)	
	Travel time	Displays accumulated key switch ON time from reset to reset.	—	L
	Travel distance	Calculates accumulated travel distance in a reset-to-reset interval based on received vehicle speed signals and displays it.	ABS actuator and electric unit (control unit)	
Possible driving distance	Calculates possible driving distance based on received fuel consumption monitor signal, vehicle speed signals and fuel level sensor signal and displays it.	ABS actuator and electric unit (control unit)	M	
		ECM		
		Fuel level sensor unit	MWI	
Ambient air temperature	Corrects ambient air temperature value based on received ambient sensor signals and displays it.	Ambient sensor		

# METER SYSTEM

< SYSTEM DESCRIPTION >

## ARRANGEMENT OF COMBINATION METER

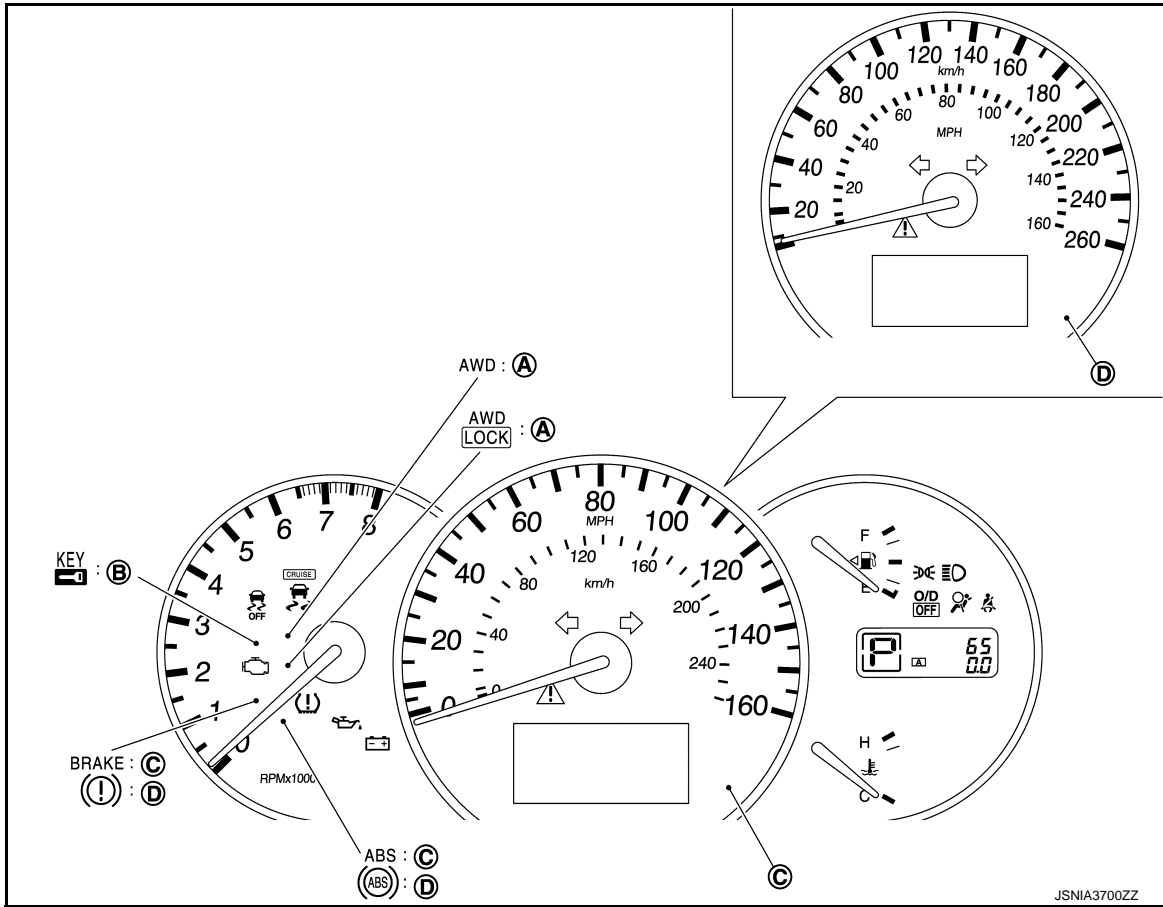

A. With AWD models

B. With Intelligent Key models

C. For U.S.A.

D. Except for U.S.A.

JSNIA3700ZZ



# METER SYSTEM

< SYSTEM DESCRIPTION >

## METER SYSTEM : Component Parts Location

INFOID:000000006262104

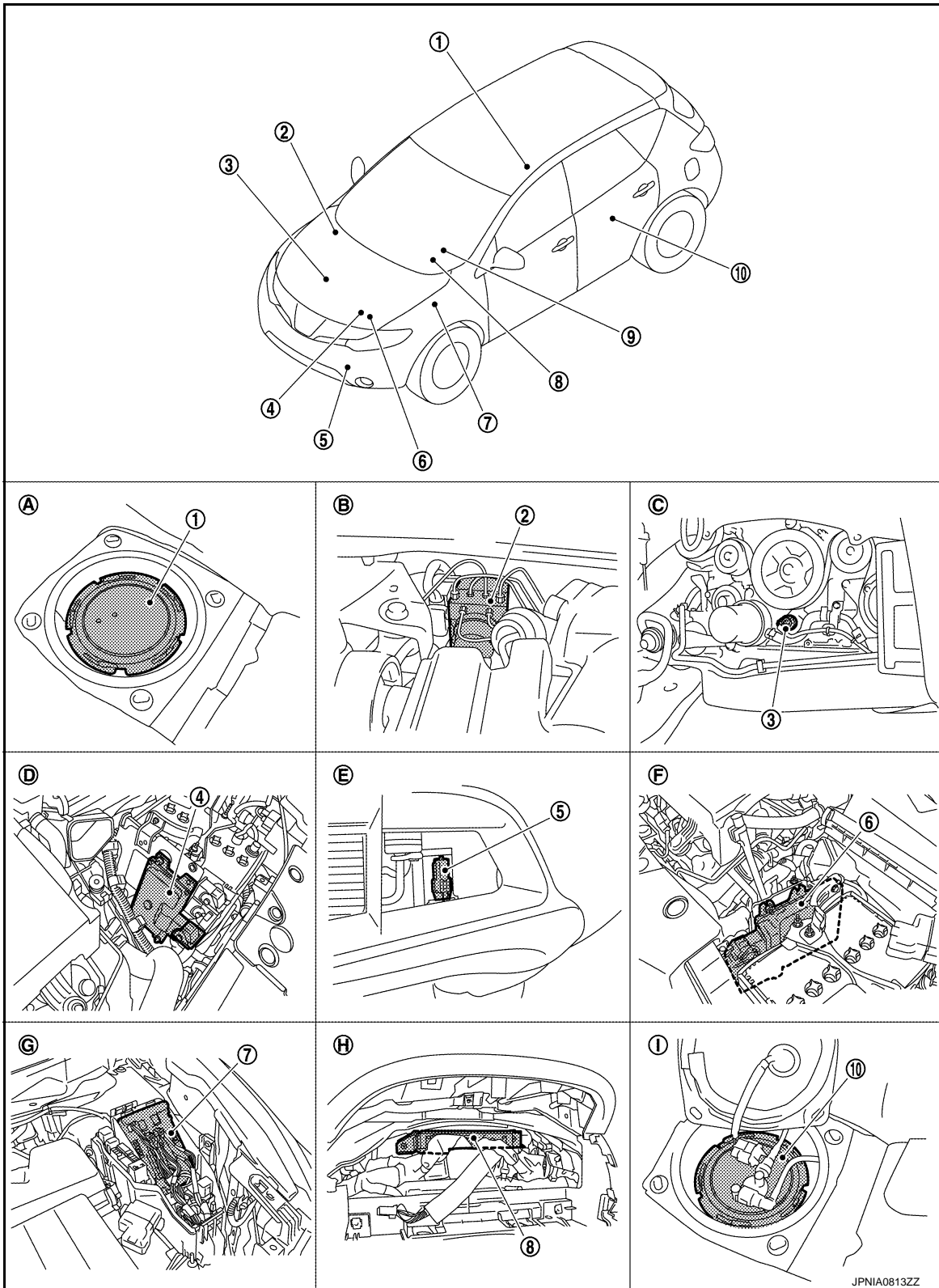

- |   |  |                        |
|---|--|------------------------|
| 1. Fuel level sensor unit (sub)                 | 2. ABS actuator and electric unit (control unit) | 3. Oil pressure switch |
| 4. TCM  | 5. Ambient sensor                                | 6. ECM                 |
| 7. IPDM E/R                                     | 8. BCM   | 9. Combination meter   |
| 10. Fuel level sensor unit and fuel pump (main) |  |                        |

A  
B  
C  
D  
E  
F  
G  
H  
I  
J  
K  
L  
M  
N  
O  
P

MWI

# METER SYSTEM

## < SYSTEM DESCRIPTION >

- |                                  |                                 |                                 |
|----------------------------------|---------------------------------|---------------------------------|
| A. Lower right side of rear seat | B. Engine room (RH)             | C. Engine front side            |
| D. Engine room (LH)              | E. Front bumper (left back)     | F. Engine room (LH)             |
| G. Engine room (LH)              | H. Behind the combination meter | I. Lower left side of rear seat |

## METER SYSTEM : Component Description

INFOID:000000006262105

Unit	Description
Combination meter	Controls the following with the signals received from each unit via CAN communication and the signals from switches and sensors. <ul style="list-style-type: none"> <li>• Speedometer</li> <li>• Engine coolant temperature gauge</li> <li>• Warning lamps</li> <li>• Information display</li> <li>• Tachometer</li> <li>• Fuel gauge</li> <li>• Indicator lamps</li> </ul>
IPDM E/R	IPDM E/R reads the ON/OFF signals of the oil pressure switch and transmits the oil pressure switch signal to the combination meter via BCM with CAN communication line.
Fuel level sensor unit	Refer to <a href="#">MWI-46, "Description"</a> .
Oil pressure switch	Refer to <a href="#">MWI-52, "Description"</a> .
ECM	Transmits the following signals to the combination meter with CAN communication line. <ul style="list-style-type: none"> <li>• Engine speed signal</li> <li>• Fuel consumption monitor signal</li> <li>• Engine coolant temperature signal</li> <li>• Fuel filler cap warning display signal</li> </ul>
ABS actuator and electric unit (control unit)	Transmits the vehicle speed signal to the combination meter with CAN communication line.
BCM	Transmits signals provided by various units to the combination meter with CAN communication line.
CVT shift selector	Transmits the O/D OFF switch signal to the combination meter.
TCM	Transmits the shift position signal to the combination meter with CAN communication line.
Meter control switch	Refer to <a href="#">MWI-49, "Description"</a> .
Washer level switch	Transmits the washer level signal to the combination meter.
Brake fluid level switch	Transmits the brake fluid level switch signal to the combination meter.
Parking brake switch	Refer to <a href="#">MWI-54, "Description"</a> .

## SPEEDOMETER

### SPEEDOMETER : System Diagram

INFOID:000000006262106

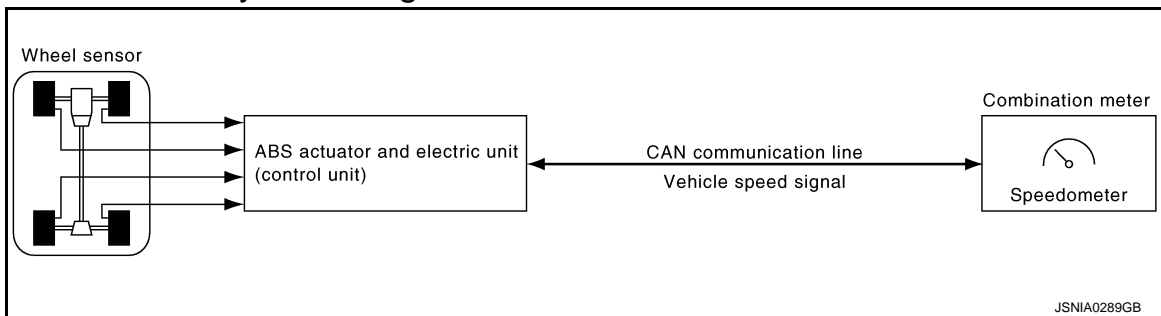

### SPEEDOMETER : System Description

INFOID:000000006262107

- The ABS actuator and electric unit (control unit) converts the rectangular wave signal provided by the wheel sensor to a vehicle speed signal and transmits it to the combination meter via CAN communication.
- The combination meter indicates the vehicle speed to the speedometer according to the vehicle speed signal received via CAN communication.

# METER SYSTEM

< SYSTEM DESCRIPTION >

## SPEEDOMETER : Component Parts Location

INFOID:000000006262108

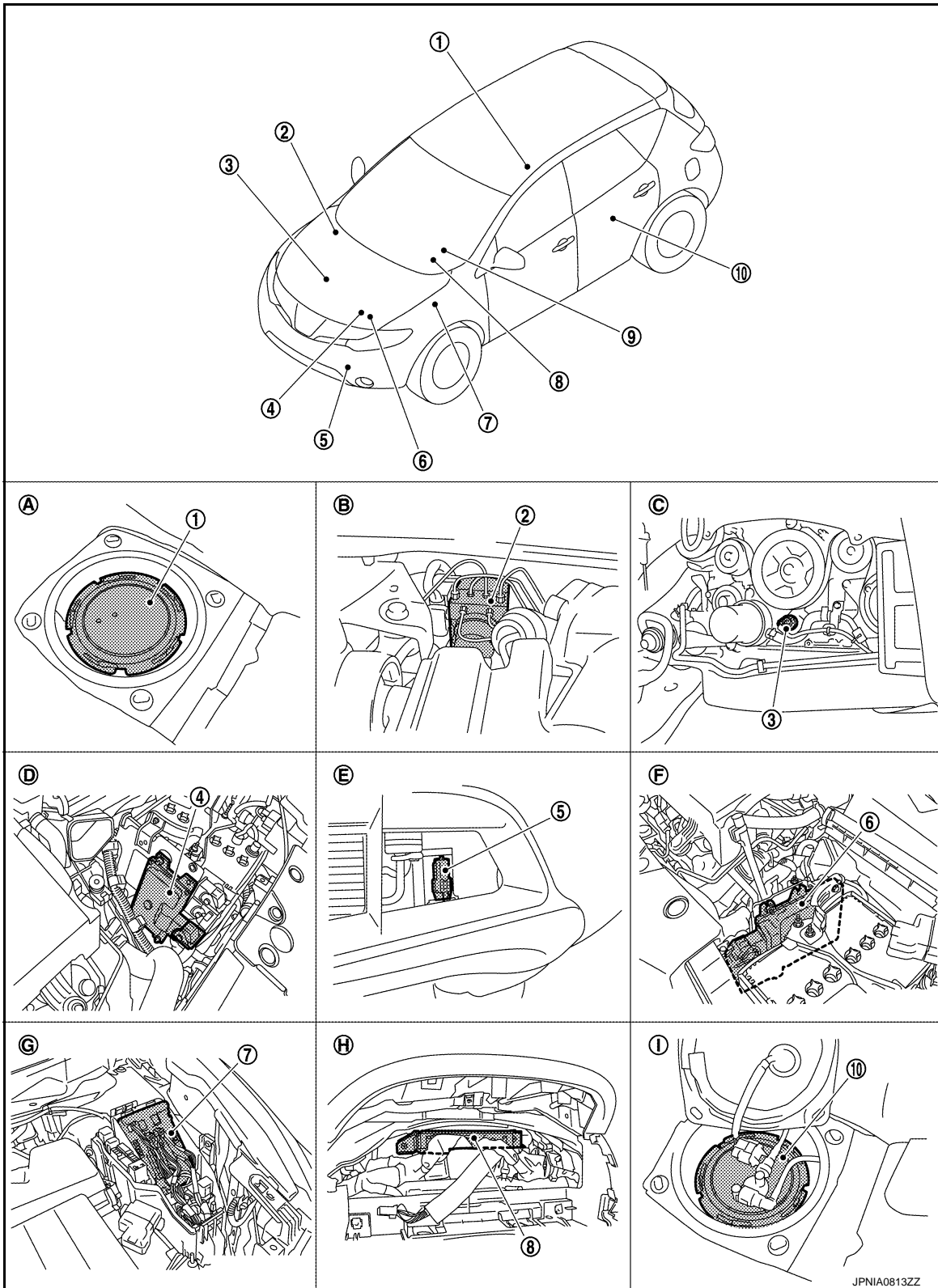

- |   |  |                        |
|---|--|------------------------|
| 1. Fuel level sensor unit (sub)                 | 2. ABS actuator and electric unit (control unit) | 3. Oil pressure switch |
| 4. TCM  | 5. Ambient sensor                                | 6. ECM                 |
| 7. IPDM E/R                                     | 8. BCM   | 9. Combination meter   |
| 10. Fuel level sensor unit and fuel pump (main) |  |                        |

JPNIA0813ZZ

A  
B  
C  
D  
E  
F  
G  
H  
I  
J  
K  
L  
M  
N  
O  
P

MWI

# METER SYSTEM

## < SYSTEM DESCRIPTION >

- |                                  |                                 |                                 |
|----------------------------------|---------------------------------|---------------------------------|
| A. Lower right side of rear seat | B. Engine room (RH)             | C. Engine front side            |
| D. Engine room (LH)              | E. Front bumper (left back)     | F. Engine room (LH)             |
| G. Engine room (LH)              | H. Behind the combination meter | I. Lower left side of rear seat |

## SPEEDOMETER : Component Description

INFOID:000000006262109

Unit	Description
Combination meter	Indicates the vehicle speed to the speedometer according to the vehicle speed signal received from ABS actuator and electric unit (control unit) via CAN communication.
ABS actuator and electric unit (control unit)	Transmits the vehicle speed signal to the combination meter with CAN communication line.

## TACHOMETER

### TACHOMETER : System Diagram

INFOID:000000006262110

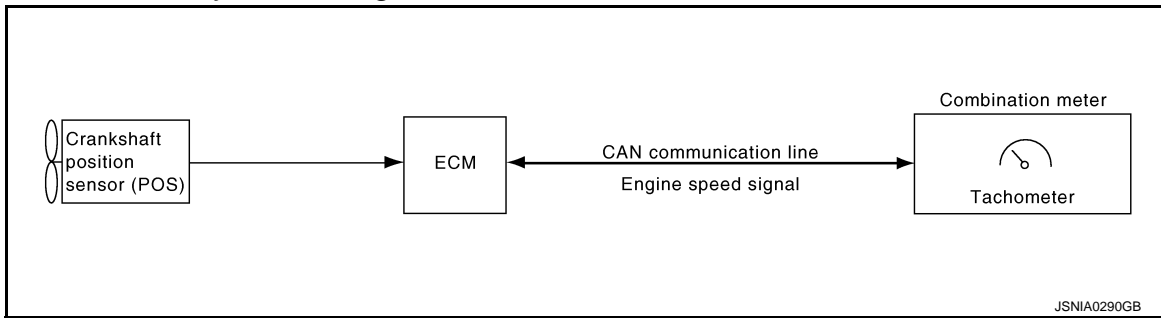

### TACHOMETER : System Description

INFOID:000000006262111

- ECM converts the pulse signal provided by the crankshaft position sensor to an engine speed signal and transmits it to the combination meter with CAN communication line.
- The combination meter indicates the engine speed to the tachometer according to the engine speed signal received via CAN communication.

# METER SYSTEM

< SYSTEM DESCRIPTION >

## TACHOMETER : Component Parts Location

INFOID:000000006262112

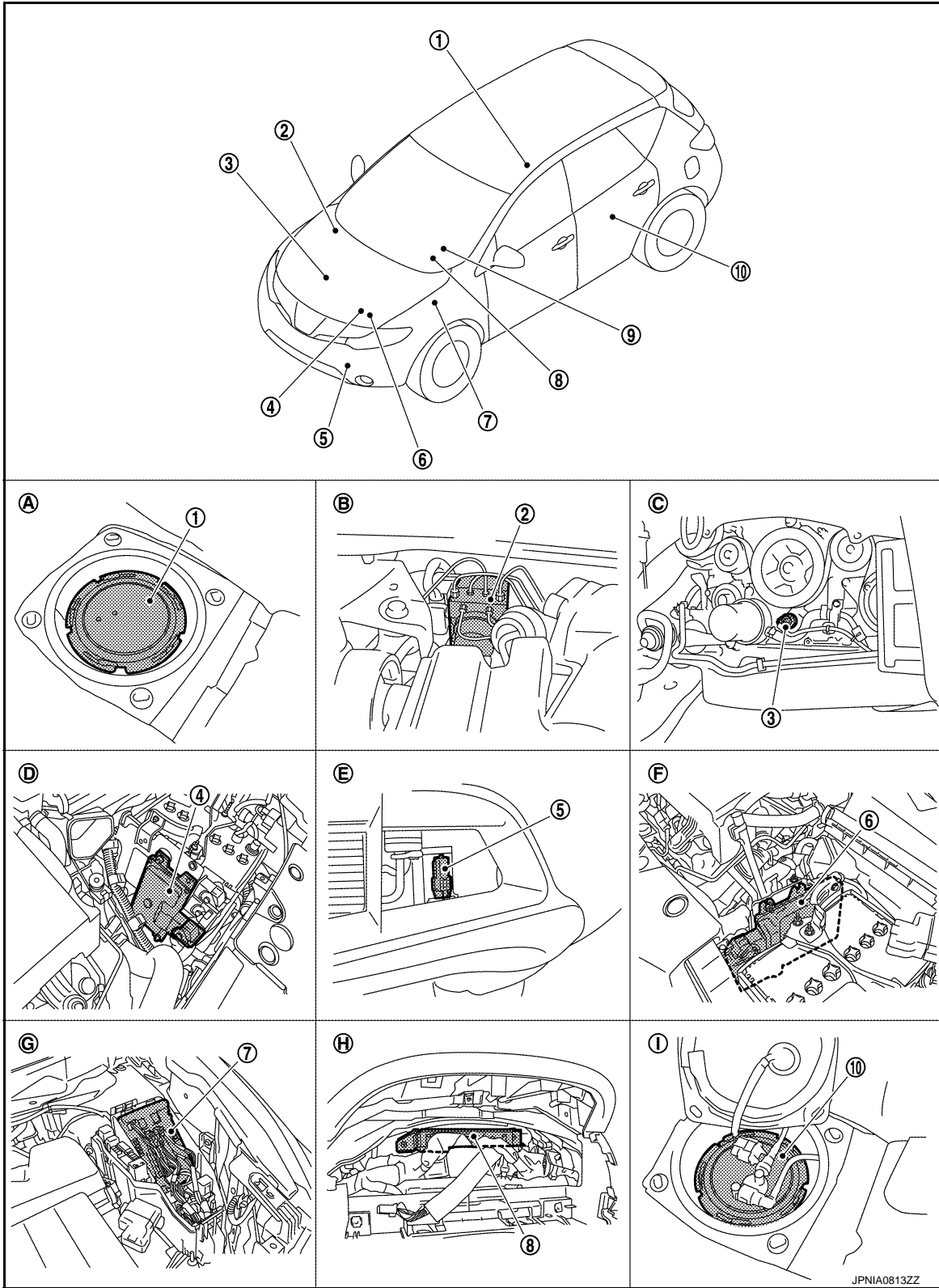

- |   |  |                        |
|---|--|------------------------|
| 1. Fuel level sensor unit (sub)                 | 2. ABS actuator and electric unit (control unit) | 3. Oil pressure switch |
| 4. TCM  | 5. Ambient sensor                                | 6. ECM                 |
| 7. IPDM E/R                                     | 8. BCM   | 9. Combination meter   |
| 10. Fuel level sensor unit and fuel pump (main) |  |                        |

JPNIA0813ZZ

A  
B  
C  
D  
E  
F  
G  
H  
I  
J  
K  
L  
M  
N  
O  
P

MWI

# METER SYSTEM

## < SYSTEM DESCRIPTION >

- |                                  |                                 |                                 |
|----------------------------------|---------------------------------|---------------------------------|
| A. Lower right side of rear seat | B. Engine room (RH)             | C. Engine front side            |
| D. Engine room (LH)              | E. Front bumper (left back)     | F. Engine room (LH)             |
| G. Engine room (LH)              | H. Behind the combination meter | I. Lower left side of rear seat |

## TACHOMETER : Component Description

INFOID:000000006262113

Unit	Description
Combination meter	Indicates the engine speed to the tachometer according to the engine speed signal received from ECM via CAN communication.
ECM	Transmits the engine speed signal to the combination meter with CAN communication line.

## ENGINE COOLANT TEMPERATURE GAUGE

### ENGINE COOLANT TEMPERATURE GAUGE : System Diagram

INFOID:000000006262114

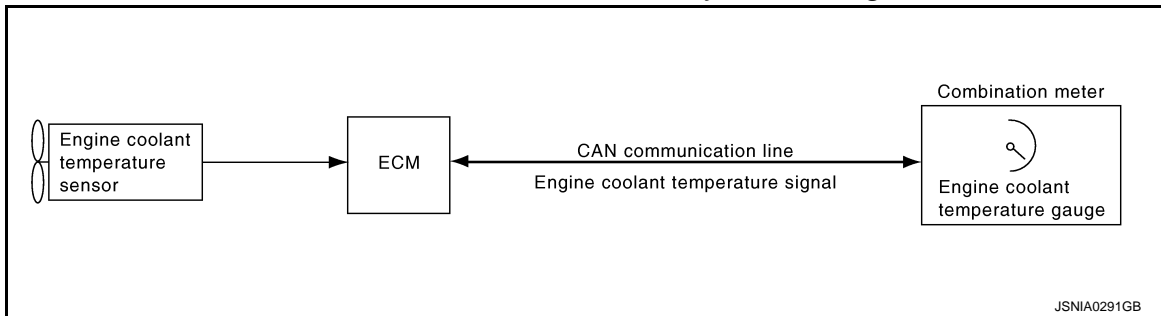

### ENGINE COOLANT TEMPERATURE GAUGE : System Description

INFOID:000000006262115

- ECM reads the engine coolant temperature signal from the engine coolant temperature sensor and transmits the signal to the combination meter via CAN communication.
- The combination meter indicates the engine coolant temperature to the engine coolant temperature gauge according to the engine coolant temperature signal received via CAN communication.

# METER SYSTEM

< SYSTEM DESCRIPTION >

## ENGINE COOLANT TEMPERATURE GAUGE : Component Parts Location

INFOID:000000006262116

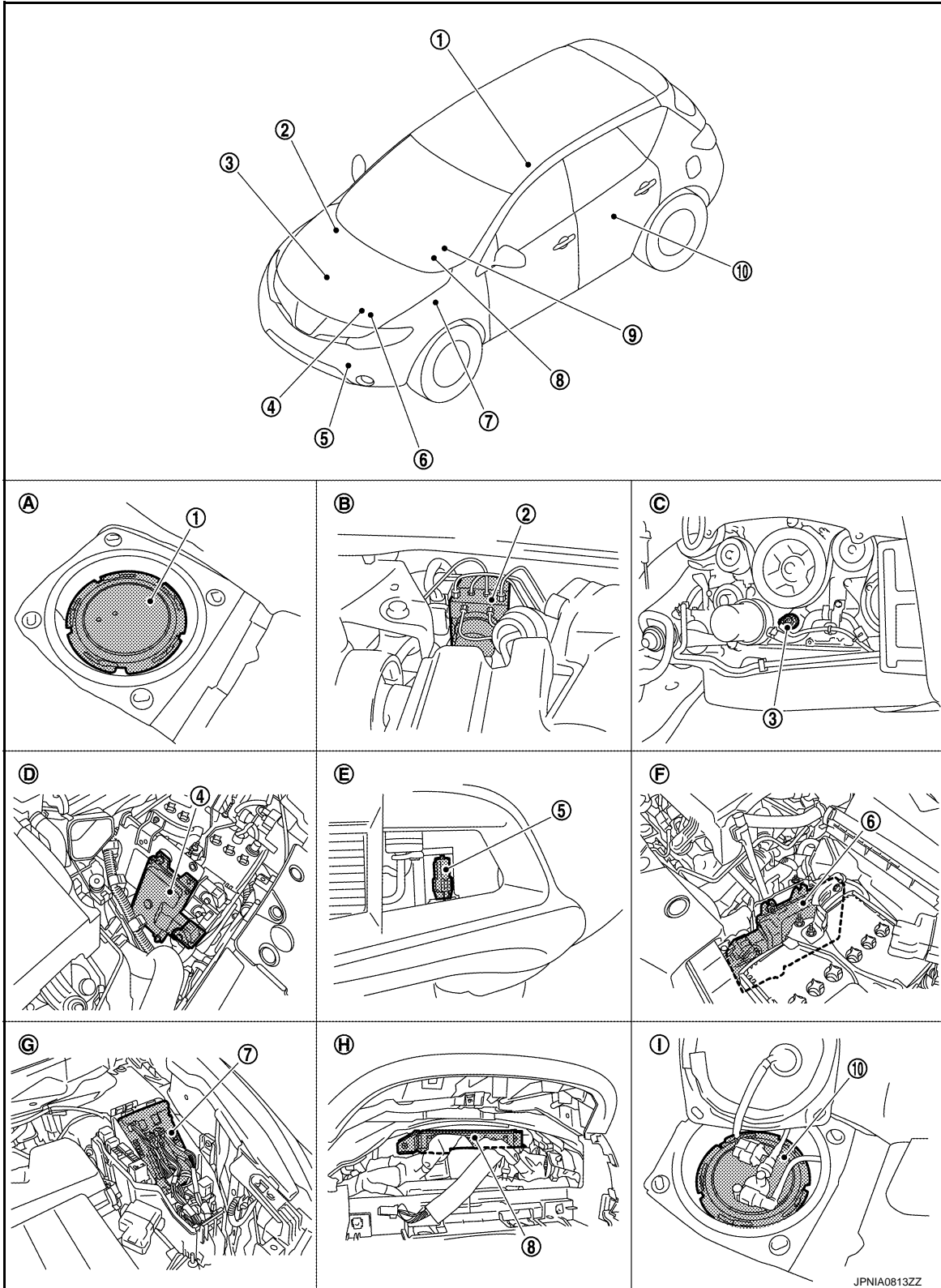

- |   |  |                        |
|---|--|------------------------|
| 1. Fuel level sensor unit (sub)                 | 2. ABS actuator and electric unit (control unit) | 3. Oil pressure switch |
| 4. TCM  | 5. Ambient sensor                                | 6. ECM                 |
| 7. IPDM E/R                                     | 8. BCM   | 9. Combination meter   |
| 10. Fuel level sensor unit and fuel pump (main) |  |                        |

A  
B  
C  
D  
E  
F  
G  
H  
I  
J  
K  
L  
M  
N  
O  
P

MWI

# METER SYSTEM

## < SYSTEM DESCRIPTION >

- |                                  |                                 |                                 |
|----------------------------------|---------------------------------|---------------------------------|
| A. Lower right side of rear seat | B. Engine room (RH)             | C. Engine front side            |
| D. Engine room (LH)              | E. Front bumper (left back)     | F. Engine room (LH)             |
| G. Engine room (LH)              | H. Behind the combination meter | I. Lower left side of rear seat |

## ENGINE COOLANT TEMPERATURE GAUGE : Component Description

INFOID:000000006262117

Unit	Description
Combination meter	Indicates the engine coolant temperature to the engine coolant temperature gauge according to the engine coolant temperature signal received from ECM via CAN communication.
ECM	Transmits the engine coolant temperature signal to the combination meter via CAN communication.

## FUEL GAUGE

### FUEL GAUGE : System Diagram

INFOID:000000006262118

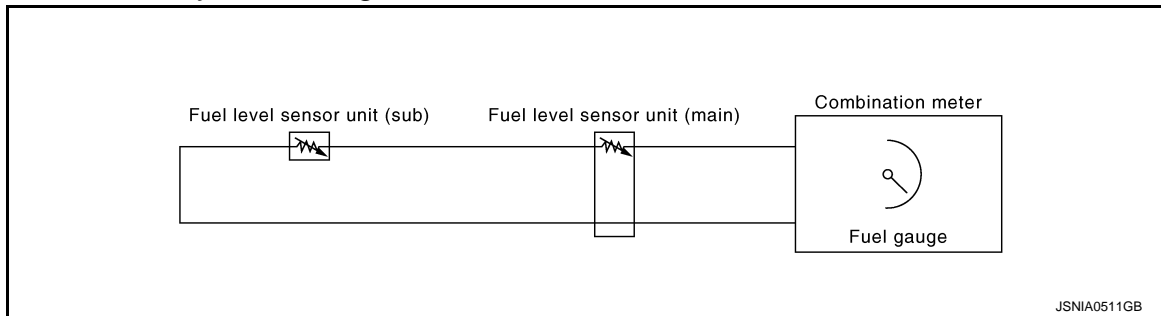

### FUEL GAUGE : System Description

INFOID:000000006262119

#### CONTROL OUTLINE

The combination meter reads the fuel level sensor signal from the fuel level sensor unit and indicates the fuel level to the fuel gauge.

#### REFUEL CONTROL

The combination meter accelerates the fuel gauge segment if the all conditions listed below are met, or the ignition switch is ON from OFF.

- Ignition switch is ON position.
- The vehicle is not moving.
- The fuel level change by 15 ℓ (4 US gal, 3-1/4 Imp gal) or more.



# METER SYSTEM

< SYSTEM DESCRIPTION >

## FUEL GAUGE : Component Parts Location

INFOID:000000006262120

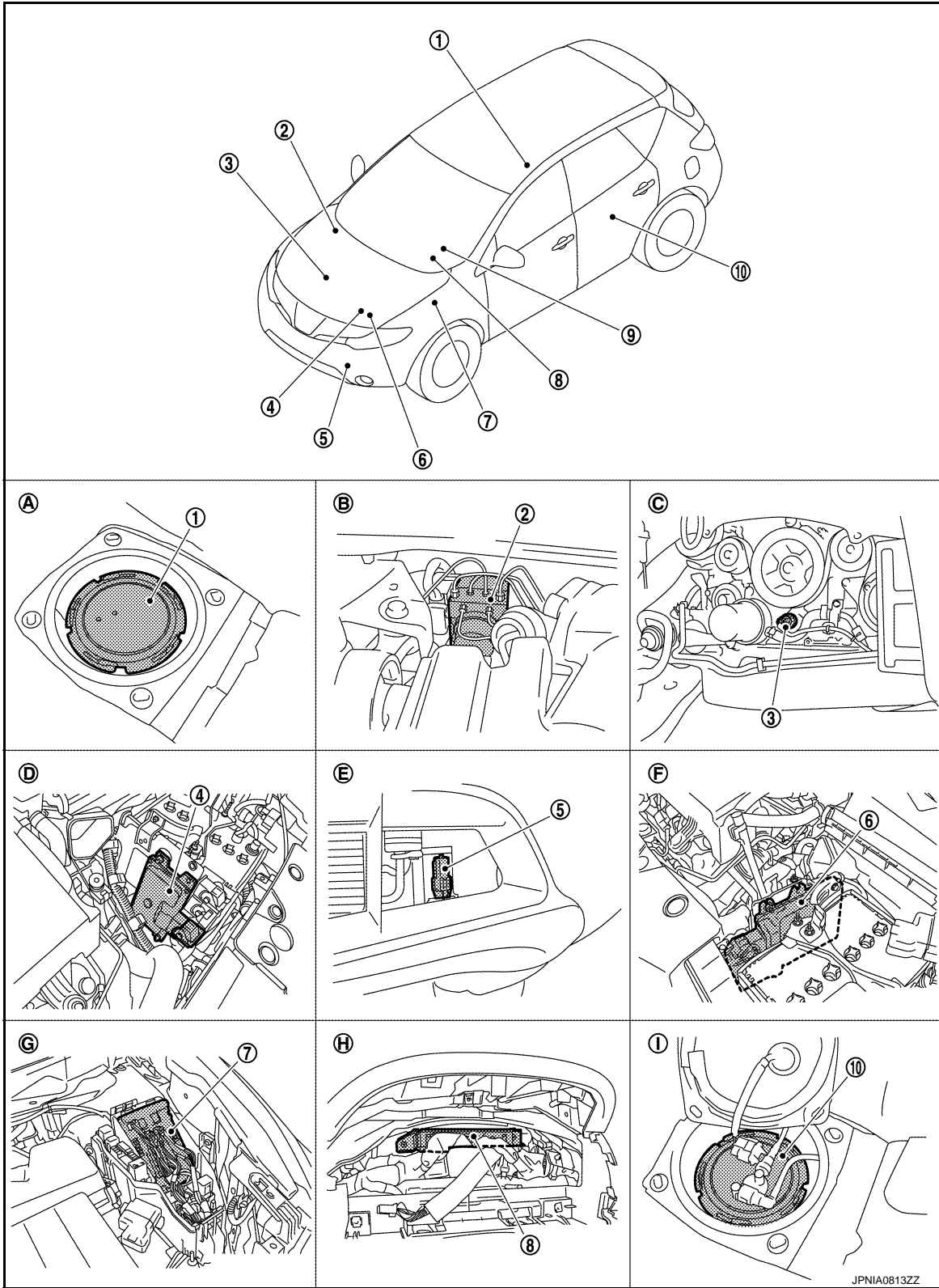

- |   |  |                        |
|---|--|------------------------|
| 1. Fuel level sensor unit (sub)                 | 2. ABS actuator and electric unit (control unit) | 3. Oil pressure switch |
| 4. TCM  | 5. Ambient sensor                                | 6. ECM                 |
| 7. IPDM E/R                                     | 8. BCM   | 9. Combination meter   |
| 10. Fuel level sensor unit and fuel pump (main) |  |                        |

JPNIA0813ZZ

A  
B  
C  
D  
E  
F  
G  
H  
I  
J  
K  
L  
M  
N  
O  
P

MWI

# METER SYSTEM

## < SYSTEM DESCRIPTION >

- |                                  |                                 |                                 |
|----------------------------------|---------------------------------|---------------------------------|
| A. Lower right side of rear seat | B. Engine room (RH)             | C. Engine front side            |
| D. Engine room (LH)              | E. Front bumper (left back)     | F. Engine room (LH)             |
| G. Engine room (LH)              | H. Behind the combination meter | I. Lower left side of rear seat |

## FUEL GAUGE : Component Description

INFOID:000000006262121

Unit	Description
Combination meter	Indicates the fuel gauge according to the fuel level sensor signal received from the fuel level sensor unit.
Fuel level sensor unit	Refer to <a href="#">MWI-46. "Description"</a> .

## ODO/TRIP METER

### ODO/TRIP METER : System Diagram

INFOID:000000006262122

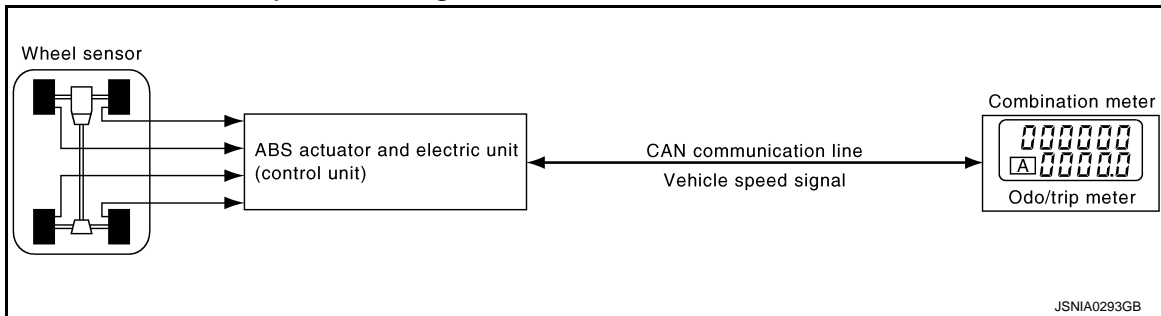

### ODO/TRIP METER : System Description

INFOID:000000006262123

- The ABS actuator and electric unit (control unit) reads the rectangular wave signal provided by the wheel sensor and transmits the vehicle speed signal to the combination meter via CAN communication.
- The combination meter converts the vehicle speed signal received via CAN communication to mileage, and it displays the accumulated mileage to the odo/trip meter.

# METER SYSTEM

< SYSTEM DESCRIPTION >

## ODO/TRIP METER : Component Parts Location

INFOID:000000006262124

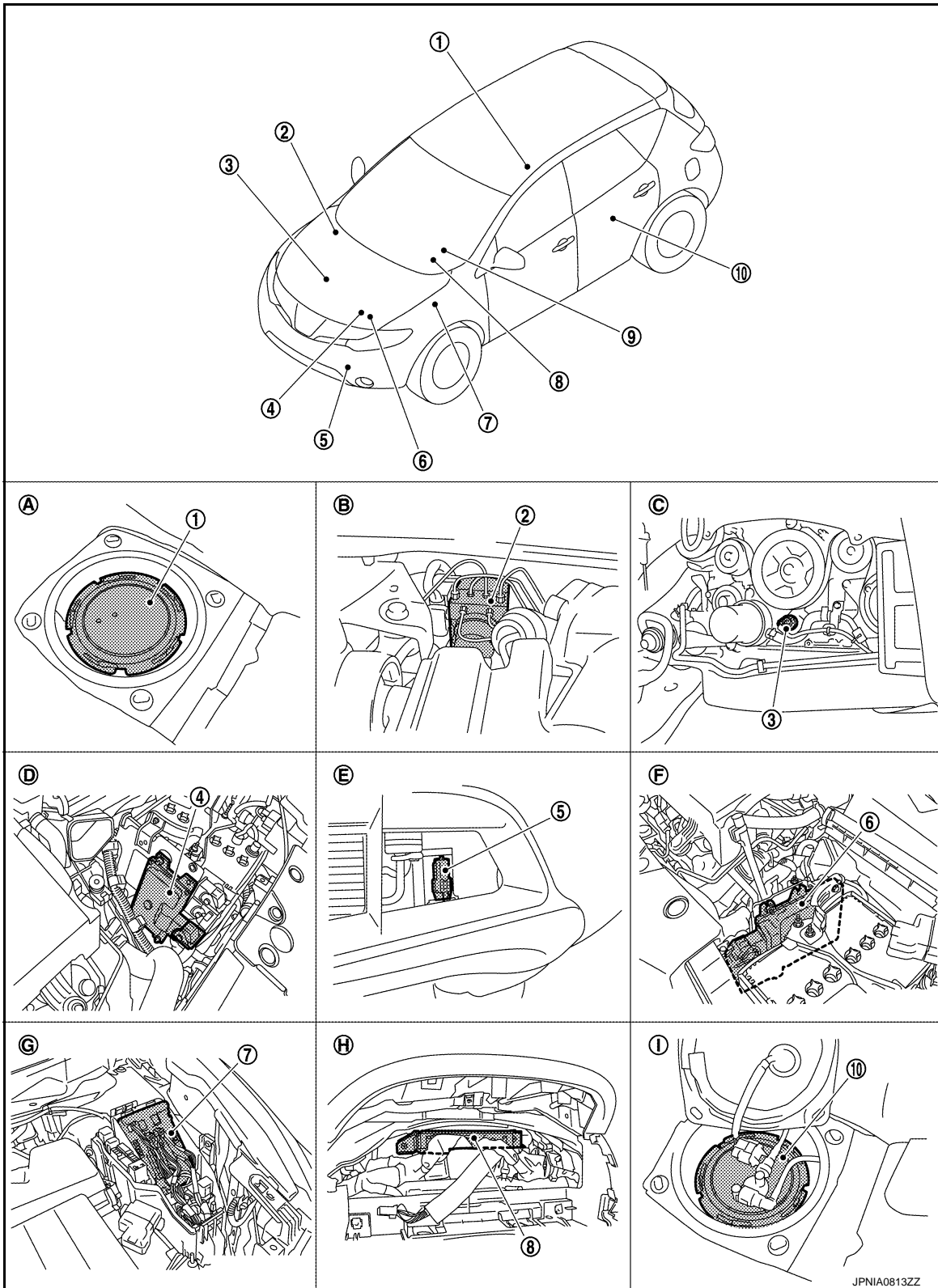

- |   |  |                        |
|---|--|------------------------|
| 1. Fuel level sensor unit (sub)                 | 2. ABS actuator and electric unit (control unit) | 3. Oil pressure switch |
| 4. TCM  | 5. Ambient sensor                                | 6. ECM                 |
| 7. IPDM E/R                                     | 8. BCM   | 9. Combination meter   |
| 10. Fuel level sensor unit and fuel pump (main) |  |                        |

JPNIA0813ZZ

A  
B  
C  
D  
E  
F  
G  
H  
I  
J  
K  
L  
M  
N  
O  
P

MWI

# METER SYSTEM

## < SYSTEM DESCRIPTION >

- |                                  |                                 |                                 |
|----------------------------------|---------------------------------|---------------------------------|
| A. Lower right side of rear seat | B. Engine room (RH)             | C. Engine front side            |
| D. Engine room (LH)              | E. Front bumper (left back)     | F. Engine room (LH)             |
| G. Engine room (LH)              | H. Behind the combination meter | I. Lower left side of rear seat |

## ODO/TRIP METER : Component Description

INFOID:000000006262125

Unit	Description
Combination meter	Converts the vehicle speed signal received from the ABS actuator and electric unit (control unit) via CAN communication to mileage, and it displays the accumulated mileage to the odo/trip meter.
ABS actuator and electric unit (control unit)	Transmits the vehicle speed signal to the combination meter via CAN communication.

## SHIFT POSITION INDICATOR

### SHIFT POSITION INDICATOR : System Diagram

INFOID:000000006262126

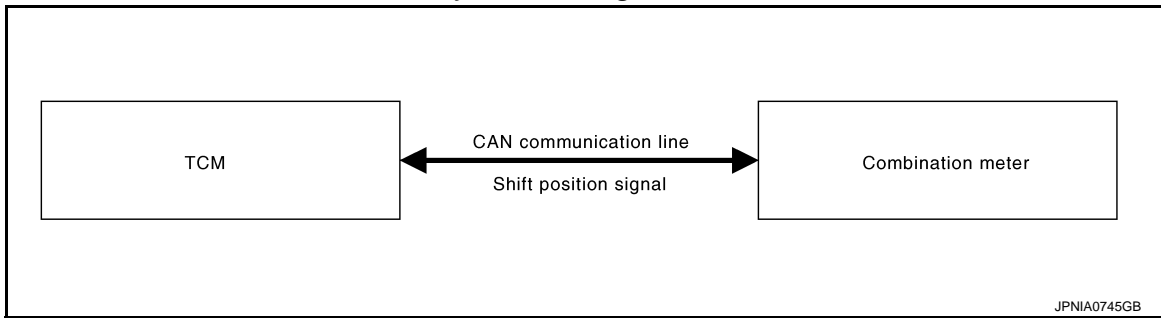

### SHIFT POSITION INDICATOR : System Description

INFOID:000000006262127

- Shift position is displayed in the shift position indicator in the combination meter.
- TCM transmits the shift position signal to the combination meter via CAN communication.
- The combination meter indicates shift position according to the shift position signal received via CAN communication.

# METER SYSTEM

< SYSTEM DESCRIPTION >

## SHIFT POSITION INDICATOR : Component Parts Location

INFOID:000000006262128

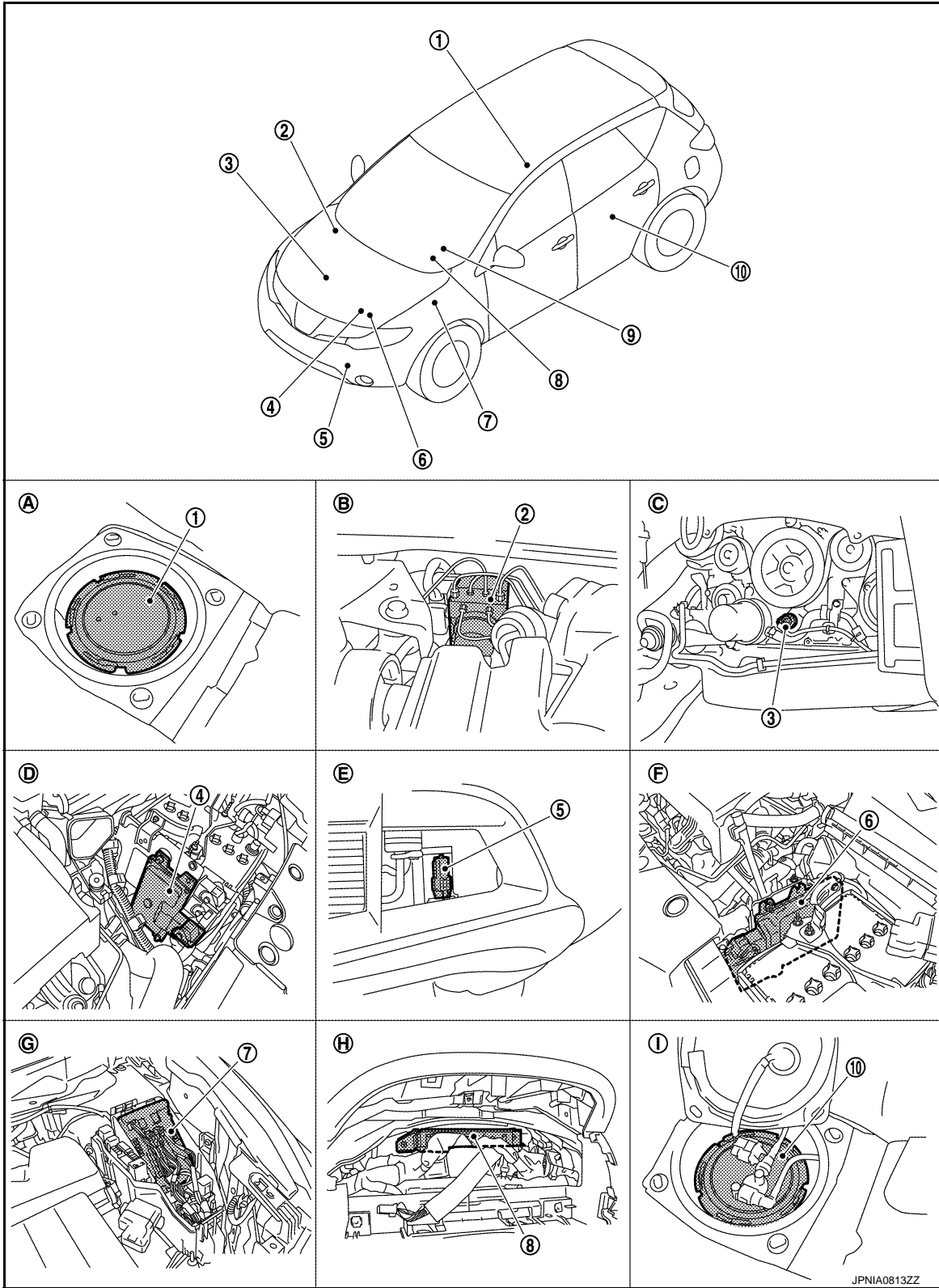

- |   |  |                        |
|---|--|------------------------|
| 1. Fuel level sensor unit (sub)                 | 2. ABS actuator and electric unit (control unit) | 3. Oil pressure switch |
| 4. TCM  | 5. Ambient sensor                                | 6. ECM                 |
| 7. IPDM E/R                                     | 8. BCM   | 9. Combination meter   |
| 10. Fuel level sensor unit and fuel pump (main) |  |                        |

JPNIA0813ZZ

A  
B  
C  
D  
E  
F  
G  
H  
I  
J  
K  
L  
M  
N  
O  
P

MWI

# METER SYSTEM

## < SYSTEM DESCRIPTION >

- |                                  |                                 |                                 |
|----------------------------------|---------------------------------|---------------------------------|
| A. Lower right side of rear seat | B. Engine room (RH)             | C. Engine front side            |
| D. Engine room (LH)              | E. Front bumper (left back)     | F. Engine room (LH)             |
| G. Engine room (LH)              | H. Behind the combination meter | I. Lower left side of rear seat |

## SHIFT POSITION INDICATOR : Component Description

INFOID:000000006262129

Unit	Description
Combination meter	Displays the shift position on the shift position indicator with shift position signal received from TCM via CAN communication.
TCM	Transmits shift position signal to the combination meter with CAN communication.

## WARNING LAMPS/INDICATOR LAMPS

### WARNING LAMPS/INDICATOR LAMPS : System Diagram

INFOID:000000006262130

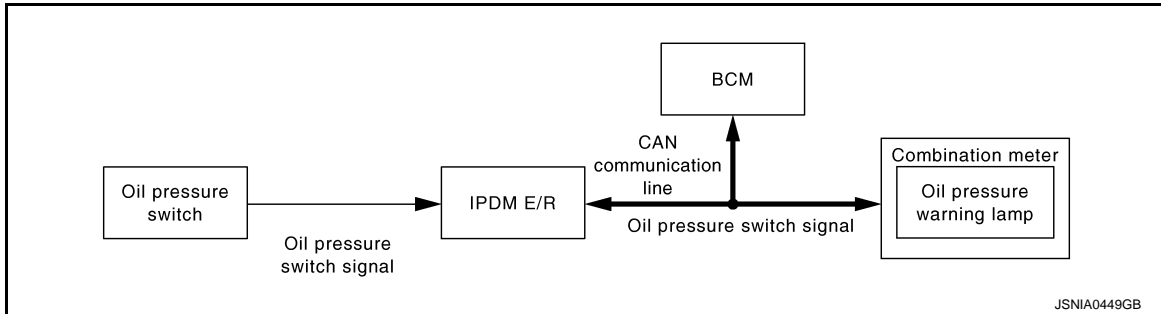

### WARNING LAMPS/INDICATOR LAMPS : System Description

INFOID:000000006262131

#### OIL PRESSURE WARNING LAMP

- IPDM E/R reads the ON/OFF signals from the oil pressure switch and transmits the oil pressure switch signal to the combination meter via BCM with the CAN communication line.
- The combination meter turns the oil pressure warning lamp ON/OFF according to the oil pressure switch signal received via CAN communication.

# METER SYSTEM

< SYSTEM DESCRIPTION >

## WARNING LAMPS/INDICATOR LAMPS : Component Parts Location

INFOID:000000006262132

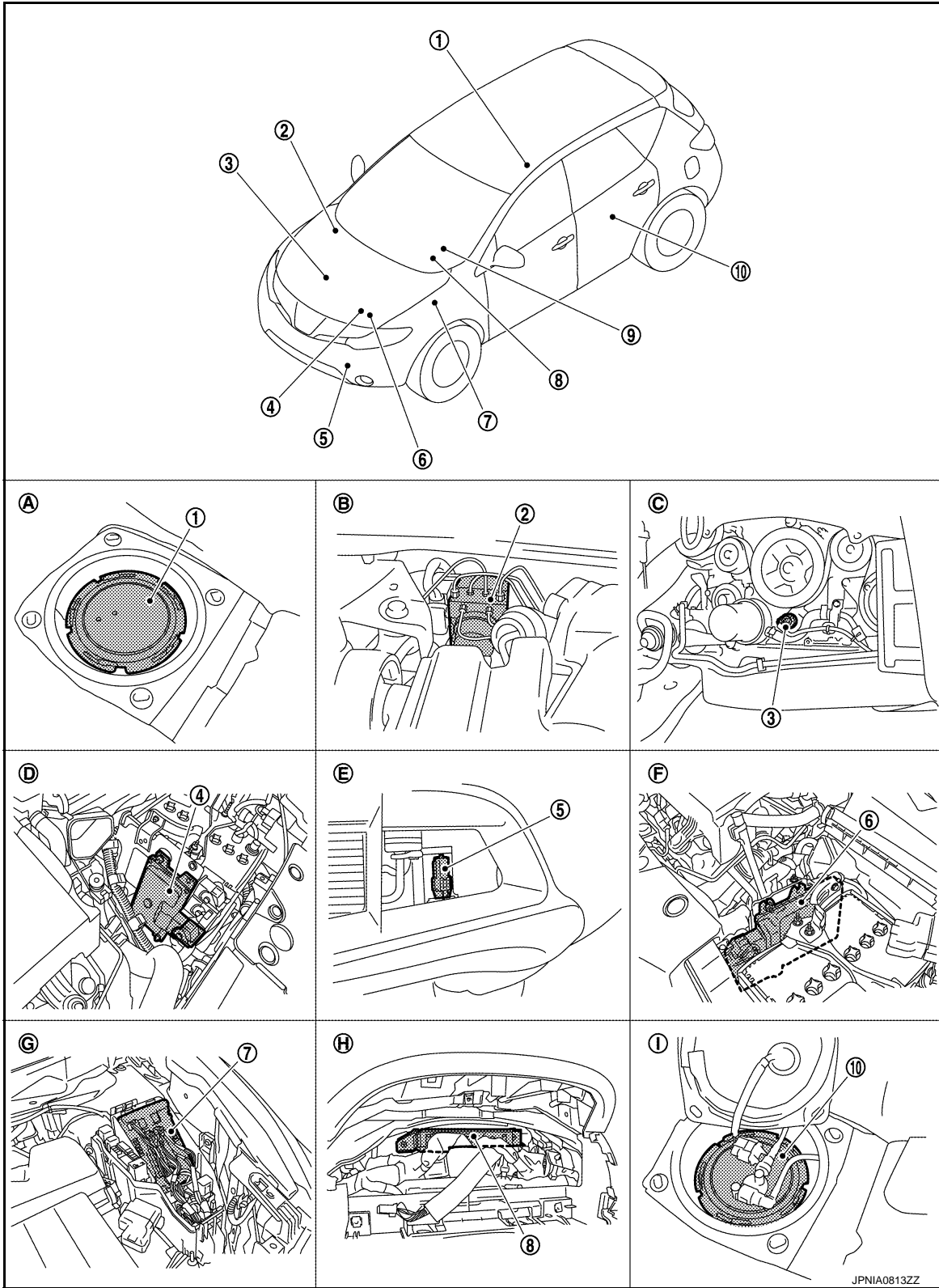

- |   |  |                        |
|---|--|------------------------|
| 1. Fuel level sensor unit (sub)                 | 2. ABS actuator and electric unit (control unit) | 3. Oil pressure switch |
| 4. TCM  | 5. Ambient sensor                                | 6. ECM                 |
| 7. IPDM E/R                                     | 8. BCM   | 9. Combination meter   |
| 10. Fuel level sensor unit and fuel pump (main) |  |                        |

JPNIA0813ZZ

A  
B  
C  
D  
E  
F  
G  
H  
I  
J  
K  
L  
M  
N  
O  
P

MWI

# METER SYSTEM

## < SYSTEM DESCRIPTION >

- |                                  |                                 |                                 |
|----------------------------------|---------------------------------|---------------------------------|
| A. Lower right side of rear seat | B. Engine room (RH)             | C. Engine front side            |
| D. Engine room (LH)              | E. Front bumper (left back)     | F. Engine room (LH)             |
| G. Engine room (LH)              | H. Behind the combination meter | I. Lower left side of rear seat |

## WARNING LAMPS/INDICATOR LAMPS : Component Description

INFOID:000000006262133

Unit	Description
Combination meter	Turns the oil pressure warning lamp ON/OFF according to the oil pressure switch signal received from BCM via CAN communication.
IPDM E/R	Reads the ON/OFF signals from the oil pressure switch and transmits the oil pressure switch signal to the combination meter via BCM and CAN communication.
Oil pressure switch	Refer to <a href="#">MWI-52, "Description"</a> .
BCM	Transmits the oil pressure switch signal received from IPDM E/R via CAN communication to the combination meter via CAN communication.

## METER ILLUMINATION CONTROL

### METER ILLUMINATION CONTROL : System Diagram

INFOID:000000006262134

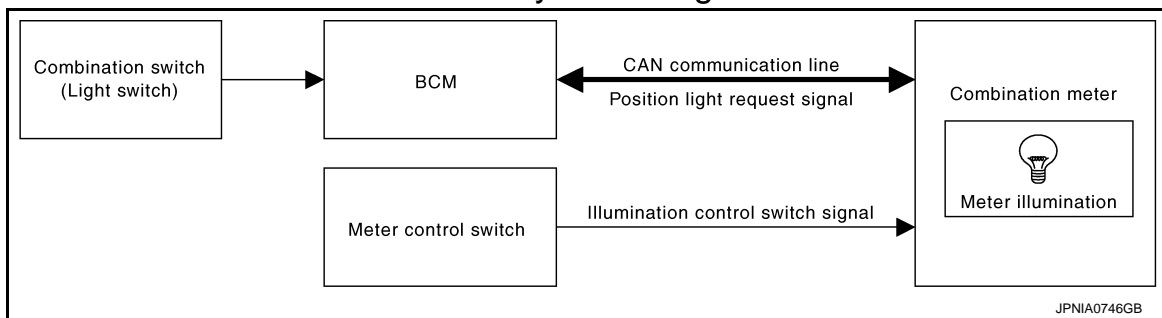

### METER ILLUMINATION CONTROL : System Description

INFOID:000000006262135

#### SYSTEM DESCRIPTION

The combination meter controls the meter illumination by the illumination control switch signal from the meter control switch and the position light request signal transmitted by the BCM via CAN communication.

#### Daytime Mode

Meter illumination level can be adjusted in 22 steps using the illumination control switch (1) in daytime mode.

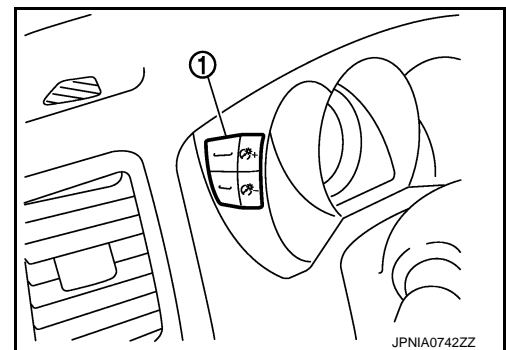

#### Nighttime Mode

- Combination meter changes the meter illumination to the nighttime mode by the position light request signal from BCM via CAN communication.
- Meter illumination can be adjusted in 22 steps using the illumination control switch in nighttime mode.

#### Driver Welcome Function

Ring illumination gradually turns ON when a driver gets in the vehicle with intelligent key and closes the driver side door.

#### NOTE:

Ring illumination gradually turns OFF when not turning the ignition switch ON at a certain period of time.



# METER SYSTEM

## < SYSTEM DESCRIPTION >

### Dial Effects Function

Combination meter detects the engine start when input engine speed signal at first. Pointers of speed meter and tachometer sweep and ring illumination gradually turns ON when combination meter detects the engine start. Then, combination meter starts the normal control.

### NOTE:

- Engine coolant temperature gauge and fuel gauge do not function.
- Dial Effects Function can be turned ON/OFF from "SETTING" on the information display.

## METER ILLUMINATION CONTROL : Component Parts Location

INFOID:000000006262136

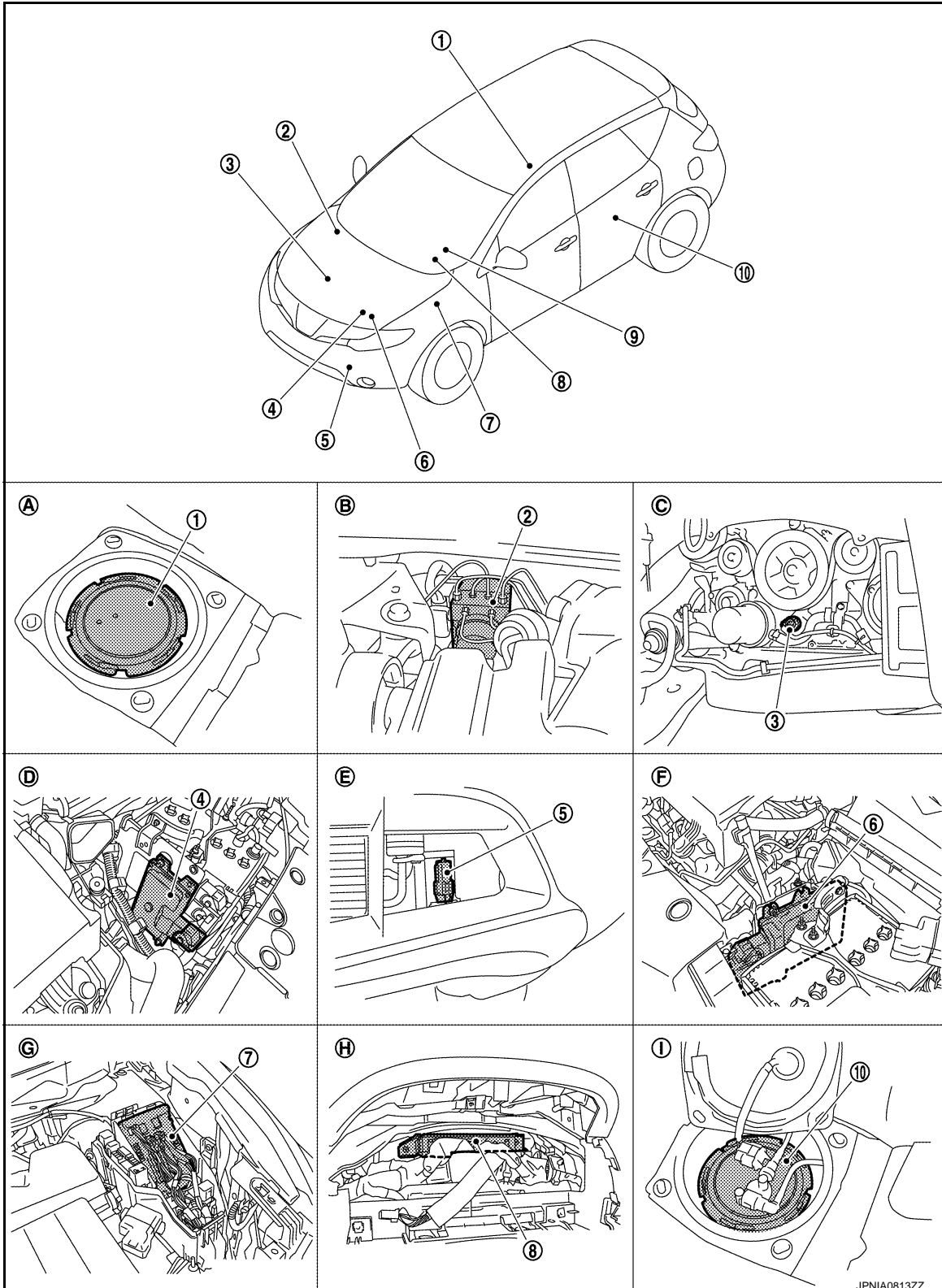

JPNIA0813ZZ

A  
B  
C  
D  
E  
F  
G  
H  
I  
J  
K  
L  
M  
N  
O  
P

MWI

# METER SYSTEM

## < SYSTEM DESCRIPTION >

- |   |  |                                 |
|---|--|---------------------------------|
| 1. Fuel level sensor unit (sub)                 | 2. ABS actuator and electric unit (control unit) | 3. Oil pressure switch          |
| 4. TCM  | 5. Ambient sensor                                | 6. ECM                          |
| 7. IPDM E/R                                     | 8. BCM   | 9. Combination meter            |
| 10. Fuel level sensor unit and fuel pump (main) |  |                                 |
| A. Lower right side of rear seat                | B. Engine room (RH)                              | C. Engine front side            |
| D. Engine room (LH)                             | E. Front bumper (left back)                      | F. Engine room (LH)             |
| G. Engine room (LH)                             | H. Behind the combination meter                  | I. Lower left side of rear seat |

## METER ILLUMINATION CONTROL : Component Description

INFOID:000000006262137

Unit	Description
Combination meter	Controls the meter illumination with the illumination control switch signal from the meter control switch and the position light request signal from BCM via CAN communication.
BCM	Transmits the position light request signal to the combination meter via CAN communication.
Meter control switch	Transmits the following signals to the combination meter. <ul style="list-style-type: none"> <li>• Illumination control switch signal (+)</li> <li>• Illumination control switch signal (-)</li> </ul>

## INFORMATION DISPLAY

### INFORMATION DISPLAY : System Diagram

INFOID:000000006262138

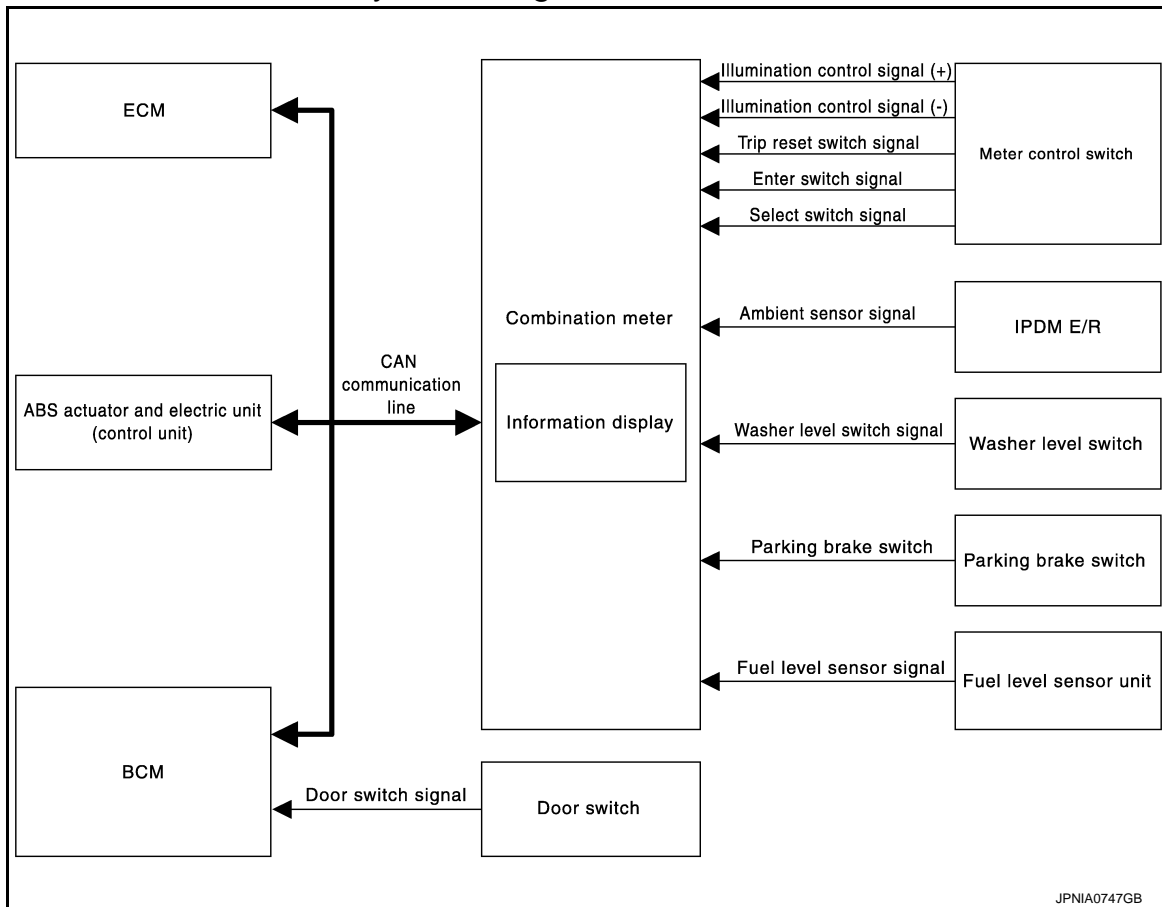

## INFORMATION DISPLAY : System Description

INFOID:000000006262139

### DESCRIPTION

# METER SYSTEM

## < SYSTEM DESCRIPTION >

- The combination meter receives the information required for controlling the operations of the information display from the BCM via CAN communication.
- The combination meter incorporates a trip computer that displays the warning / information according to the information received from various units.

### PARKING BRAKE RELEASE WARNING

The combination meter indicates the parking brake release warning judged by the vehicle speed signal received from the ABS actuator and electric unit (control unit) via CAN communication and the parking brake switch signal from the parking brake switch.

#### Warning Operation Condition

Parking brake release warning is judged if all of the following conditions are fulfilled.

- Vehicle speed is 7 km/h (4.3 MPH) or higher
- Parking brake switch ON

### LOW FUEL WARNING

The combination meter indicates the low fuel warning judged by the fuel level sensor signal received from the fuel level sensor unit.

#### Warning Operation Condition

- Fuel level: Approx. 11 ℓ (2-7/8 US gal, 2-3/8 Imp gal) or less

### LOW WASHER FLUID WARNING

The combination meter indicates the low washer fluid warning judged by the signal from the washer level switch.

#### Warning Operation Condition

- Indicates the warning when the washer level switch is ON for 180 seconds or more. Stops indicating the warning when the washer level switch is OFF for 30 seconds or more.

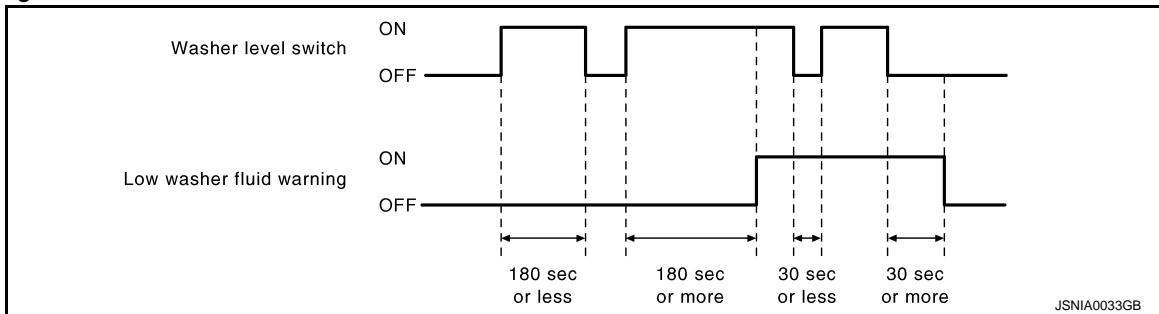

### LOW TIRE PRESSURE WARNING

- The combination meter receives remaining TPMS display signal from the BCM with CAN communication line.
- The combination meter indicates low tire pressure warning when receiving remaining TPMS display signal.
- The combination meter indicates low tire pressure warning judged with the TPMS display signal received from the BCM.

For details, refer to [WT-8, "System Description"](#).

### FUEL FILLER CAP WARNING

- The combination meter receives remaining fuel filler cap warning display signal from the ECM with CAN communication line.
- The combination meter indicates fuel filler cap warning when receiving remaining fuel filler cap warning display signal.
- The combination meter indicates fuel filler cap warning judged with the fuel filler cap warning display signal received from the ECM.

For details, refer to [EC-108, "System Description"](#).

### DOOR OPEN WARNING

- The combination meter indicates the door open warning judged by each door switch signal received from the BCM via CAN communication line.

### INSTANTANEOUS FUEL CONSUMPTION

- The combination meter receives the fuel consumption monitor signal from the ECM and the vehicle speed signal from the ABS actuator and electric unit (control unit) via CAN communication.

A  
B  
C  
D  
E  
F  
G  
H  
I  
J  
K  
L  
M  
O  
P

MWI

# METER SYSTEM

## < SYSTEM DESCRIPTION >

---

- The combination meter calculates instantaneous fuel consumption according to the fuel consumption monitor signal and the vehicle speed signal received via CAN communication.

### AVERAGE FUEL CONSUMPTION

- The combination meter receives the fuel consumption monitor signal from the ECM and the vehicle speed signal from the ABS actuator and electric unit (control unit) via CAN communication.
- The combination meter calculates the average fuel consumption according to the fuel consumption monitor signal and the vehicle speed signal received via CAN communication.
- The average fuel consumption displayed on the information display is uploaded in approximately 30-second intervals.

#### **NOTE:**

When turning ON the ignition switch after triggering a reset or removing/installing the battery, “—” is indicated until 30-seconds/500 m (0.31 miles) of driving.

### AVERAGE VEHICLE SPEED

- The combination meter receives the vehicle speed signal from the ABS actuator and electric unit (control unit) via CAN communication.
- Measures the time while the ignition switch is ON through the combination meter.
- The combination meter the average vehicle speed according to the above signals.
- The average vehicle speed displayed on the information display is uploaded in approximately 30-second intervals.

#### **NOTE:**

When turning ON the ignition switch after triggering a reset or removing/installing the battery, “—” is indicated until 30 seconds.

### TRAVEL TIME

Measures the time while the ignition switch is ON through the combination meter.

### TRAVEL DISTANCE

- The combination meter receives the vehicle speed signal from the ABS actuator and electric unit (control unit) via CAN communication.
- The combination meter calculates the vehicle distance according to the vehicle speed signal. The vehicle distance is displayed.

### POSSIBLE DRIVING DISTANCE

The combination meter calculates possible driving distance according to the vehicle speed signal and fuel consumption monitor signal transmitted via CAN communication and the fuel level sensor signal transmitted from the fuel level sensor.

#### **NOTE:**

- When turning ON the ignition switch after removing/installing the battery, “—” is indicated until 30 seconds.
- The indicated values may not match each other when refueling with the ignition switch ON. Refer to [MWI-101, "INFORMATION DISPLAY : Description"](#).

### AMBIENT AIR TEMPERATURE

- The combination meter receives the ambient sensor signal from the ambient sensor.
- The combination meter calculates the ambient temperature according to the ambient sensor signal.
- The indicated temperature does not increase if the vehicle speed is less than 20 km/h (12 MPH).

#### **NOTE:**

- The ambient sensor input value that is displayed on “Data Monitor” of CONSULT-III is the value before the correction. It may not match the indicated temperature on the information display.
- The ambient temperature may be indicated higher than the actual temperature, depending on heat in the engine, the road surface temperature, and so on.

### SETTING

# METER SYSTEM

## < SYSTEM DESCRIPTION >

### Setting item list

Items		Setting range	Setting unit	Description
ALERT	TIME TO REST	No setting - 6 hours	30 minutes, [60 minutes]*	Time to rest is displayed on the information display if the vehicle reached the set travel distance.
	ICY	ON/OFF	—	Low outside temp is displayed on the information display if the ambient temperature is 3°C (37°F) or less.
MAINTENANCE	ENGINE OIL	No setting - 18,500 miles, (No setting - 30,000 km)	250 miles (500 km), [500 miles (1,000 km)]*	The engine oil replacement interval is displayed on the information display if the vehicle reached the set distance.
	OIL FILTER	No setting - 18,500 miles, (No setting - 30,000 km)	250 miles (500 km), [500 miles (1,000 km)]*	The oil filter replacement interval is displayed on the information display if the vehicle reached the set distance.
	TIRE	No setting - 18,500 miles, (No setting - 30,000 km)	250 miles (500 km), [500 miles (1,000 km)]*	The tire replacement interval is displayed on the information display if the vehicle reached the set distance.
	OTHER	No setting - 18,500 miles, (No setting - 30,000 km)	250 miles (500 km), [500 miles (1,000 km)]*	The other replacement interval is displayed on the information display if the vehicle reached the set distance.
DISPLAY	LANGUAGE	ENGLISH/FRANCAIS	—	The language setting can be changed.
	UNIT	US/METRIC	—	The unit setting can be changed.
	DIAL EFFECTS	ON/OFF	—	The dial effects setting can be changed.

\* : Press and hold the switch (1 second or more).

A  
B  
C  
D  
E  
F  
G  
H  
I  
J  
K  
L  
M  
N  
O  
P

MWI

# METER SYSTEM

< SYSTEM DESCRIPTION >

## INFORMATION DISPLAY : Component Parts Location

INFOID:000000006262140

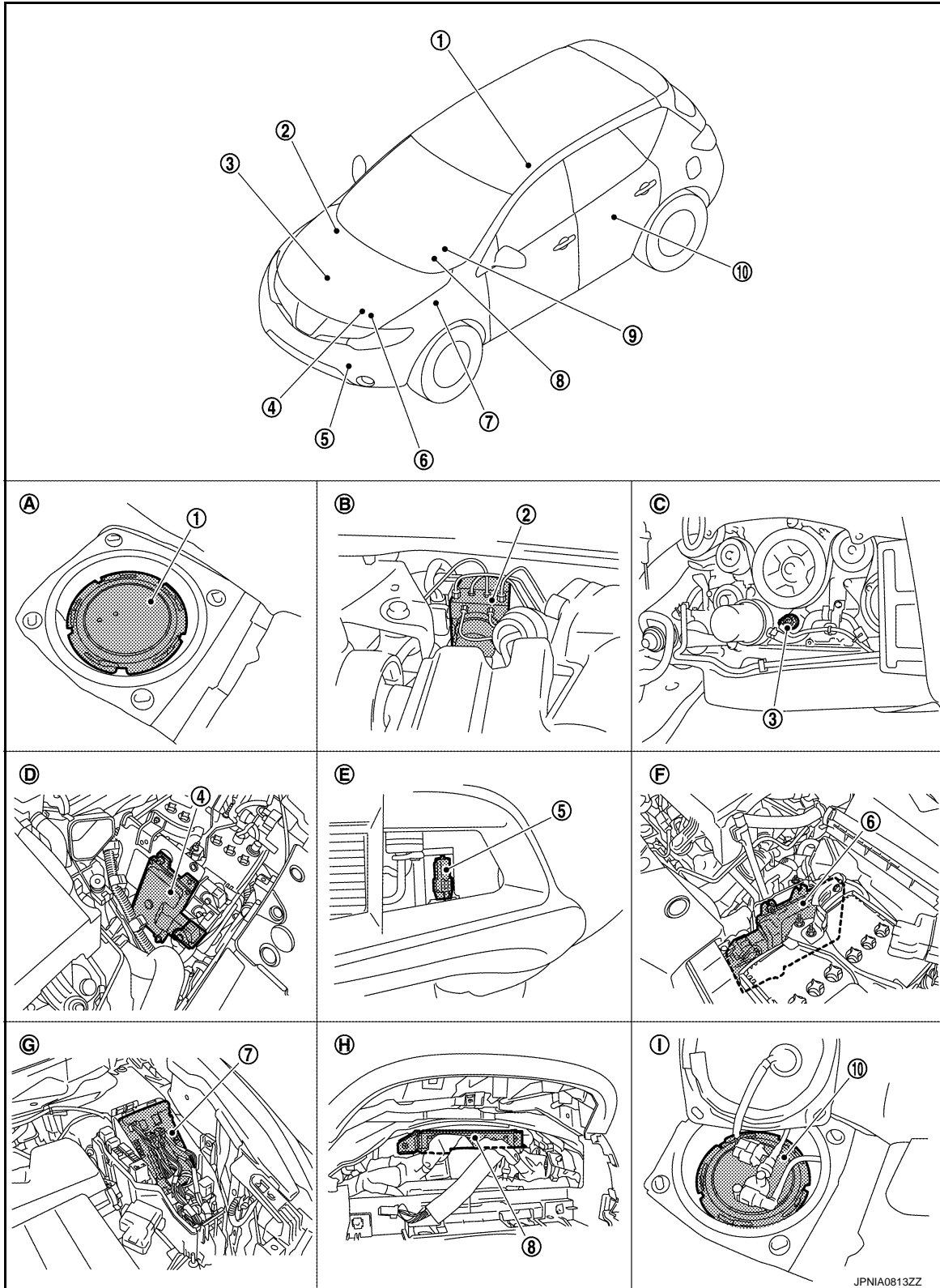

- |   |  |                        |
|---|--|------------------------|
| 1. Fuel level sensor unit (sub)                 | 2. ABS actuator and electric unit (control unit) | 3. Oil pressure switch |
| 4. TCM  | 5. Ambient sensor                                | 6. ECM                 |
| 7. IPDM E/R                                     | 8. BCM   | 9. Combination meter   |
| 10. Fuel level sensor unit and fuel pump (main) |  |                        |

# METER SYSTEM

## < SYSTEM DESCRIPTION >

- |                                  |                                 |                                 |
|----------------------------------|---------------------------------|---------------------------------|
| A. Lower right side of rear seat | B. Engine room (RH)             | C. Engine front side            |
| D. Engine room (LH)              | E. Front bumper (left back)     | F. Engine room (LH)             |
| G. Engine room (LH)              | H. Behind the combination meter | I. Lower left side of rear seat |

## INFORMATION DISPLAY : Component Description

INFOID:000000006262141

Unit	Description
Combination meter	Controls the information display according to the signal received from each unit.
Fuel level sensor unit	Refer to <a href="#">MWI-46, "Description"</a> .
ECM	Transmits the following signals to the combination meter via CAN communication. <ul style="list-style-type: none"> <li>• Engine speed signal</li> <li>• Fuel filler cap warning display signal</li> <li>• Fuel consumption monitor signal</li> </ul>
ABS actuator and electric unit (control unit)	Transmits the vehicle speed signal to the combination meter via CAN communication.
BCM	Transmits signals provided by various units to the combination meter via CAN communication.
Meter control switch	Transmits the following signals to the combination meter. <ul style="list-style-type: none"> <li>• Enter switch signal</li> <li>• Select switch signal</li> </ul>
Washer level switch	Transmits the washer level signal to the combination meter.
Parking brake switch	Refer to <a href="#">MWI-54, "Description"</a> .
Door switch	Transmits the door switch signals to BCM.
IPDM E/R	Transmits the ambient sensor signal to the combination meter.
Ambient sensor	Detects the ambient air temperature and transmits the ambient sensor signal to the IPDM E/R.

A  
B  
C  
D  
E  
F  
G  
H  
I  
J  
K  
L  
M  
N  
O  
P

MWI

# COMPASS

< SYSTEM DESCRIPTION >

## COMPASS

### Description

INFOID:000000006262142

### DESCRIPTION

- This electronic compass is able to display 8 primary directions: N, NE, E, SE, S, SW, W, NW.
- The compass switch (1) is used to operate the compass.

#### Switch Operation

Press	Compass is turned ON/OFF
Press and hold (for 3- 9 sec.)	Compass display (2) turns to zone variation change mode
Press and hold (for more than 9 sec.)	Compass display turns to calibration mode

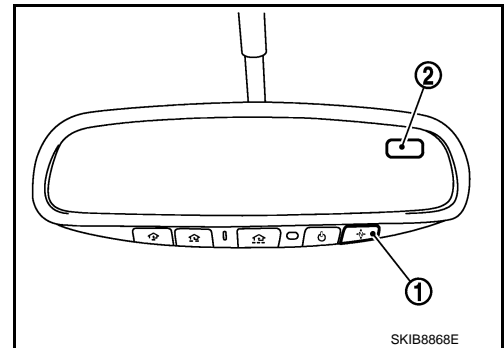

- All standard compasses determine direction relative to magnetic north, however, this electronic compass is designed to display direction relative to true north.
- The difference between magnetic north and true north varies from place to place across the surface of the earth.
- This electronic compass must be “told” approximately where it is on the earth’s surface so that the magnetic north reading can be properly converted into a true north display.
- To tell the electronic compass where it’s at, the earth is separated into numbered “Zone Variances”. The zone variance number in which the compass is to function must be entered into this electronic compass.
- Each zone is magnetically about 4.2° wide. Typically, anything under a 22.5° total zone change is not noticed on the electronic compass display. However, if a change over 22.5° occurs, a reading may be off by one or more primary directions.
- On long trips, the vehicle may leave its original zone and enter one or more new zones. Generally, you do not need to reset the compass zone if you travel between 3 or 4 zones, such as business travel or vacation. The typical driver will not notice any difference on the display within 3 or 4 zones. However, if the vehicle is “permanently” moved to a new location, it is recommended that the compass zone be reset.

### ZONE VARIATION SETTING PROCEDURE

1. Press and hold the compass switch for 3 – 9 seconds.
2. The current zone setting appears on the compass display.
3. Find the current geographical location number in the zone variation chart.
4. Select the new zone number. (Press the compass switch until the new zone number appears on the compass display.)
5. After select the new zone number, the compass display will automatically shows a direction within a few seconds.
6. Perform the following calibration procedure for more accurate indications.

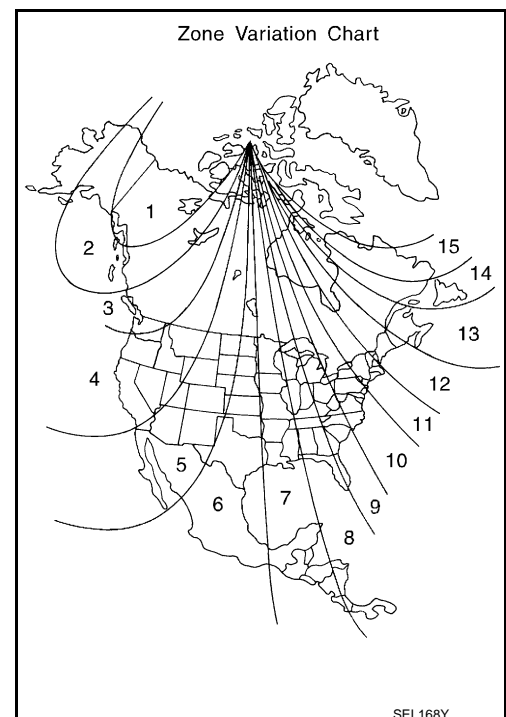



# COMPASS

## < SYSTEM DESCRIPTION >

### CALIBRATION PROCEDURE

#### NOTE:

The compass calibrates itself under normal driving conditions. However, occasional circumstances may cause the compass to operate inaccurately. Example: Driving from rural (wide open) areas to crowded city areas, or if an aftermarket (i.e., non original equipment) antenna with a magnetic base is attached to the vehicle. Calibrate the mirror compass if the display shows only one direction or a limited number of directions.

#### NOTE:

- If “magnetic hats” are used in the dealership for vehicle identification, remove the hat from the vehicle before performing the following steps. Do not put the hat back on the vehicle after the procedure is completed.
- Drive the vehicle to an open level area; away from large metallic objects, structures, and overhead power lines.
- Turn off “non-essential” electrical accessories (rear window defrost, heater/air conditioning, wipers) and close the doors.

1. Verify the correct compass zone setting for the geographical location.
2. Press and hold the compass switch for more than 9 seconds.
3. “C” is displayed on the compass display when calibration starts.
4. Drive slowly [less than 8 km/h (5 MPH)] in a circle until the “C / CAL” is replaced with primary headings (N, NE, E, SE, S, SW, W, or NW).

#### NOTE:

This will require driving at least 2 complete 360 degree circles, 3 complete circles may be required.

5. The compass calibration procedure is now complete. The compass should operate normally.

#### NOTE:

If at any time the compass continually displays the incorrect direction or the reading is erratic or locked, repeat the calibration procedure.

### Component Parts Location

INFOID:000000006262143

- 1 : Compass switch
- 2 : Compass display

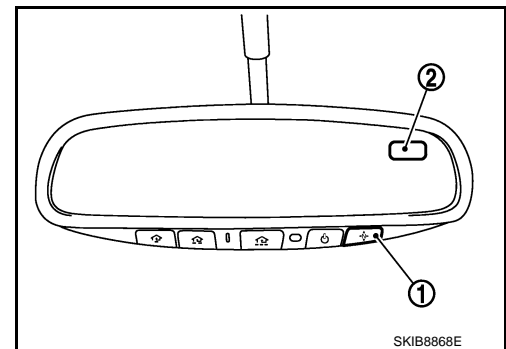

### Special Repair Requirement

INFOID:000000006262144

#### 1.PERFORM ZONE VARIATION SETTING

Perform the zone variation setting. Refer to [MWI-32, "Description"](#).

>> GO TO 2.

#### 2.PERFORM CALIBRATION

Perform the calibration. Refer to [MWI-32, "Description"](#).

>> Setting completion

# DIAGNOSIS SYSTEM (METER)

< SYSTEM DESCRIPTION >

## DIAGNOSIS SYSTEM (METER)

### Diagnosis Description

INFOID:000000006262145

### SELF-DIAGNOSIS MODE

- Information display LCD segment operation can be checked in self-diagnosis mode.
- Meters/gauges can be checked in self-diagnosis mode.

### OPERATION PROCEDURE

1. Turn ignition switch OFF.
2. While pressing the trip reset switch (1), turn ignition switch ON.  
**NOTE:**  
If the diagnosis function is activated with "trip A" displayed, the mileage on "trip A" is reset to "0000.0". (The same way for "trip B".)
3. Make sure that the trip meter displays "0000.0".
4. Press the trip reset switch at least 3 times. (Within 7 seconds after the ignition switch is turned ON.)

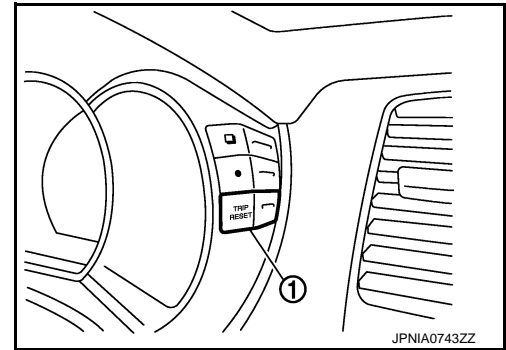

5. The unified meter control unit is turned to self-diagnosis mode.
  - All the segments on the odo/trip meter and shift position indicator illuminate.
  - The segment dots of the information display LCD (1) blink alternately.
  - Engine coolant temperature gauge and fuel gauge return to zero, simultaneously.

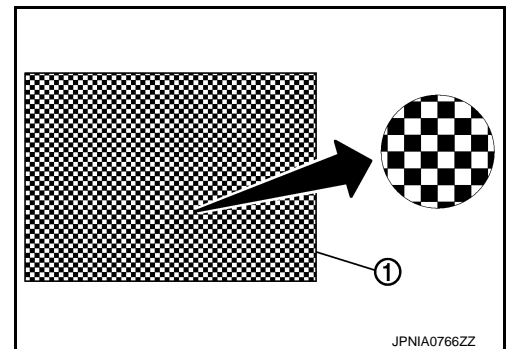

### NOTE:

- Check combination meter power supply and ground circuit when the self-diagnosis mode of the combination meter does not start. Replace combination meter if abnormal.
  - If any of the segments are not displayed, replace combination meter.
6. Each meter activates by pressing the trip reset switch.

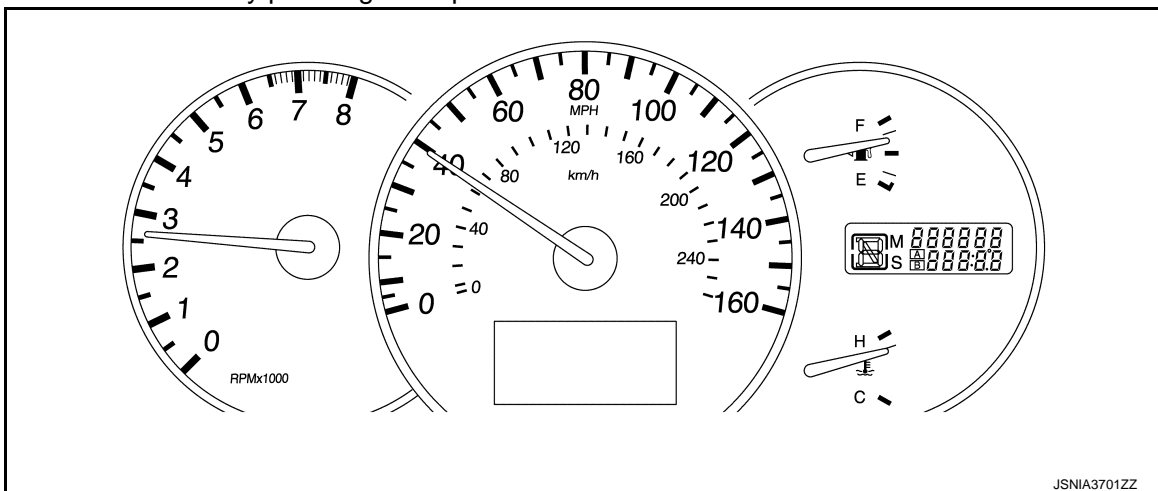

### NOTE:

# DIAGNOSIS SYSTEM (METER)

## < SYSTEM DESCRIPTION >

- If any of the meters or gauges are not activated, replace combination meter.
- The figure is reference.

## CONSULT-III Function (METER/M&A)

INFOID:000000006262146

### CONSULT-III APPLICATION ITEMS

CONSULT-III can perform the following diagnosis modes via CAN communication and the combination meter.

System	Diagnosis mode	Description
METER/M&A	Self Diagnostic Result	The combination meter checks the conditions and displays memorized errors.
	Data Monitor	Displays the combination meter input/output data in real time.
	Special function	Lighting history of the warning lamp and indicator lamp can be checked.

### SELF DIAG RESULT

Refer to [MWI-77, "DTC Index"](#).

### DATA MONITOR

#### Display Item List

X: Applicable

Display item [Unit]	MAIN SIGNALS	Description
SPEED METER [km/h]	X	Value of vehicle speed signal received from ABS actuator and electric unit (control unit) via CAN communication. <b>NOTE:</b> 655.35 is displayed when the malfunction signal is received.
SPEED OUTPUT [km/h]	X	Vehicle speed signal value transmitted to other units via CAN communication. <b>NOTE:</b> 655.35 is displayed when the malfunction signal is received.
ODO OUTPUT [km/h or mph]		Odometer signal value transmitted to other units via CAN communication.
TACHO METER [rpm]	X	Value of the engine speed signal received from ECM via CAN communication. <b>NOTE:</b> 8191.875 is displayed when the malfunction signal is received.
FUEL METER [L]	X	Fuel level indicated on combination meter.
W TEMP METER [°C]	X	Value of engine coolant temperature signal is received from ECM via CAN communication. <b>NOTE:</b> 215 is displayed when the malfunction signal is input.
FUEL CAP W/L [On/Off]		Status of fuel filler cap warning display detected from fuel filler cap warning display signal received from ECM via CAN communication.
ABS W/L [On/Off]		Status of ABS warning lamp detected from ABS warning lamp signal is received from ABS actuator and electric unit (control unit) via CAN communication.
VDC/TCS IND [On/Off]		Status of VDC OFF indicator lamp detected from VDC OFF indicator lamp signal is received from ABS actuator and electric unit (control unit) via CAN communication.
SLIP IND [On/Off]		Status of SLIP indicator lamp detected from slip indicator lamp signal received from ABS actuator and electric unit (control unit) via CAN communication.
BRAKE W/L [On/Off]		Status of brake warning lamp detected from brake warning lamp signal is received from ABS actuator and electric unit (control unit) via CAN communication. <b>NOTE:</b> Displays "Off" if the brake warning lamp is illuminated when the valve check starts, the parking brake switch is turned ON or the brake fluid level switch is turned ON.
DOOR W/L [On/Off]		Status of door warning detected from door switch signal received from BCM via CAN communication.



## DIAGNOSIS SYSTEM (METER)

### < SYSTEM DESCRIPTION >

Display item [Unit]	MAIN SIGNALS	Description
HI-BEAM IND [On/Off]		Status of high beam indicator lamp detected from high beam request signal is received from BCM via CAN communication.
TURN IND [On/Off]		Status of turn indicator lamp detected from turn indicator signal is received from BCM via CAN communication.
LIGHT IND [On/Off]		Status of light indicator lamp detected from position light request signal is received from BCM via CAN communication.
OIL W/L [On/Off]		Status of oil pressure warning lamp detected from oil pressure switch signal is received from BCM via CAN communication.
MIL [On/Off]		Status of malfunction indicator lamp detected from malfunctioning indicator lamp signal is received from ECM via CAN communication.
CRUISE IND [On/Off]		Status of CRUISE indicator detected from ASCD status signal is received from ECM via CAN communication.
O/D OFF IND [On/Off]		Status of O/D OFF indicator detected from O/D OFF indicator signal is received from CVT shift selector.
4WD W/L [On/Off]		Status of AWD warning lamp detected from AWD warning lamp signal is received from AWD control unit via CAN communication.
4WD LOCK IND [On/Off]		Status of AWD LOCK warning lamp detected from AWD LOCK warning lamp signal is received from AWD control unit via CAN communication.
FUEL W/L [On/Off]		Low-fuel warning lamp status detected by the identified fuel level.
WASHER W/L [On/Off]		Status of washer warning lamp judged from washer level switch input to combination meter.
AIR PRES W/L [On/Off]		Status of low tire pressure warning lamp detected from tire pressure signal is received from BCM via CAN communication.
KEY G/W W/L [On/Off]		Status of key warning lamp (G/Y) detected from key warning signal is received from BCM via CAN communication.
LCD [B&P N, B&P I, ID NG, ROTAT, SFT P, INSRT, BATT, NO KY, OUTKY, LK WN]		Displays status of Intelligent Key system warning detected from meter display signal is received from BCM via CAN communication.
SHIFT IND [P, R, N, D, L]		Status of shift position indicator detected from shift position signal is received from TCM via CAN communication.
O/D OFF SW [On/Off]		Status of O/D OFF switch.
M RANGE SW [Off]		This item is displayed, but cannot be monitored.
NM RANGE SW [Off]		This item is displayed, but cannot be monitored.
AT SFT UP SW [Off]		This item is displayed, but cannot be monitored.
AT SFT DWN SW [Off]		This item is displayed, but cannot be monitored.
ST SFT UP SW [Off]		This item is displayed, but cannot be monitored.
ST SFT DWN SW [Off]		This item is displayed, but cannot be monitored.
PKB SW [On/Off]		Status of parking brake switch.
BUCKLE SW [On/Off]		Status of seat belt buckle switch (driver side).
BRAKE OIL SW [On/Off]		Status of brake fluid level switch.

# DIAGNOSIS SYSTEM (METER)

## < SYSTEM DESCRIPTION >

Display item [Unit]	MAIN SIGNALS	Description
DISTANCE [km]		Value of possible driving distance calculated by combination meter.
A/C AMP CONN [On/Off]		Status of A/C auto amp. connection recognition signal.
ENTER SW [On/Off]		Status of  (ENTER) switch.
SELECT SW [On/Off]		Status of  (SELECT) switch.
OUTSIDE TEMP [°C or °F]		Ambient air temperature value converted from ambient sensor signal received from ambient sensor. <b>NOTE:</b> This may not match with the temperature value indicated on the information display. (Because the information display value is a corrected value from the ambient sensor input value.)
FUEL LOW SIG [On/Off]		Status of fuel level low warning signal to output to AV control unit via CAN communication.
BUZZER [On/Off]	X	Buzzer status (in the combination meter) is detected from the buzzer output signal received from each unit via CAN communication and the warning output condition of the combination meter.

### NOTE:

Some items are not available according to vehicle specification.

## SPECIAL FUNCTION

### Special menu

Display item	Description
W/L ON HISTORY	Lighting history of warning lamp and indicator lamp can be checked.

### W/L ON HISTORY

- Stores histories when warning/indicator lamp is turned on.
- “W/L ON HISTORY” indicates the “TIME” when the warning/indicator lamp is turned on.
- The “TIME” above is :
  - 0 : The condition that the warning/indicator lamp has been turned on 1 or more times after starting the engine and waiting for 30 seconds.
  - 1 - 39 : The number of times the engine was restarted after the 0 condition.
  - NO W/L ON HISTORY : Stores NO (0) turning on history of warning/indicator lamp.

### NOTE:

- W/L ON HISTORY is not stored for approximately 30 seconds after the engine starts.
- Brake warning lamp does not store any history when the parking the brake is applied or the brake fluid level gets low.

### Display Item

Display item	Description
ABS W/L	Lighting history of ABS warning lamp.
VDC/TCS IND	Lighting history of VDC OFF indicator lamp.
SLIP IND	Lighting history of SLIP indicator lamp.
BRAKE W/L	Lighting history of brake warning lamp.
DOOR W/L	Lighting history of door warning.
OIL W/L	Lighting history of oil pressure warning lamp.
C-ENG W/L	Lighting history of malfunction indicator lamp.
CRUISE IND	Lighting history of CRUISE indicator lamp.
SET IND	Lighting history of SET indicator.

## DIAGNOSIS SYSTEM (METER)

### < SYSTEM DESCRIPTION >

Display item	Description
O/D OFF IND	Lighting history of O/D OFF indicator lamp.
4WD W/L	Lighting history of AWD warning lamp.
FUEL W/L	Lighting history of low fuel level warning.
WASHER W/L	Lighting history of low washer fluid warning
AIR PRES W/L	Lighting history of low tire pressure warning lamp.
KEY G/Y W/L	Lighting history of key warning lamp (green/yellow).
KEY R W/L	Lighting history of key warning lamp (red).
CHAGE W/L	Lighting history of charge warning lamp.

**NOTE:**

In items displayed on the CONSULT screen, only those listed in the above table are used.

# U1000 CAN COMM CIRCUIT

< DTC/CIRCUIT DIAGNOSIS >

## DTC/CIRCUIT DIAGNOSIS

### U1000 CAN COMM CIRCUIT

#### Description

INFOID:000000006262147

CAN (Controller Area Network) is a serial communication system for real time application. It is an on-vehicle multiplex communication system with high data communication speed and excellent error detectability. Many electronic control units are equipped onto vehicles, and each control unit shares information and links with other control units during operation (not independent). In CAN communication, control units are connected with two communication lines (CAN-H line, CAN-L line) allowing a high rate of information transmission with less wiring. Each control unit transmits/receives data but selectively reads required data only. CAN Communication Signal Chart. Refer to [LAN-25, "CAN Communication Signal Chart"](#).

#### DTC Logic

INFOID:000000006262148

#### DTC DETECTION LOGIC

DTC	Display contents of CONSULT-III	Diagnostic item is detected when ...	Probable malfunction location
U1000	CAN COMM CIRCUIT	When combination meter is not transmitting or receiving CAN communication signal for 2 seconds or more.	CAN communication system

#### Diagnosis Procedure

INFOID:000000006262149

#### 1.PERFORM SELF DIAGNOSTIC

1. Turn ignition switch ON and wait for 2 seconds or more.
2. Check "Self Diagnostic Result" of "METER/M&A".

Is "CAN COMM CIRCUIT" displayed?

- YES >> Refer to [LAN-15, "Trouble Diagnosis Flow Chart"](#).  
NO >> Refer to [GI-44, "Intermittent Incident"](#).

A  
B  
C  
D  
E  
F  
G  
H  
I  
J  
K  
L  
M  
O  
P

MWI

# U1010 CONTROL UNIT (CAN)

< DTC/CIRCUIT DIAGNOSIS >

## U1010 CONTROL UNIT (CAN)

### Description

INFOID:000000006262150

Initial diagnosis of combination meter.

### DTC Logic

INFOID:000000006262151

### DTC DETECTION LOGIC

DTC	Display contents of CONSULT-III	Diagnostic item is detected when ...	Probable malfunction location
U1010	CONTROL UNIT (CAN)	If any malfunction is detected during initial diagnosis of combination meter CAN controller	Combination meter

### Diagnosis Procedure

INFOID:000000006262152

#### 1. REPLACE COMBINATION METER

When DTC "U1010" is detected, replace combination meter.

>> INSPECTION END



# B2205 VEHICLE SPEED

< DTC/CIRCUIT DIAGNOSIS >

## B2205 VEHICLE SPEED

### Description

INFOID:000000006262153

Vehicle speed signal is transmitted from ABS actuator and electric unit (control unit) via CAN communication to combination meter.

### DTC Logic

INFOID:000000006262154

### DTC DETECTION LOGIC

DTC	Display contents of CONSULT-III	Diagnostic item is detected when ...	Probable malfunction location
B2205	VEHICLE SPEED	An abnormal vehicle speed signal is input from ABS actuator and electric unit (control unit) for 2 seconds or more	<ul style="list-style-type: none"><li>• Wheel sensor</li><li>• ABS actuator and electric unit (control unit)</li></ul>

### Diagnosis Procedure

INFOID:000000006262155

#### 1. PERFORM SELF-DIAGNOSIS OF ABS ACTUATOR AND ELECTRIC UNIT (CONTROL UNIT)

Perform "Self Diagnostic Result" of ABS actuator and electric unit (control unit), and repair or replace malfunctioning parts.

>> Refer to [BRC-28, "CONSULT-III Function"](#).

A  
B  
C  
D  
E  
F  
G  
H  
I  
J  
K  
L  
M  
O  
P

MWI

## B2267 ENGINE SPEED

< DTC/CIRCUIT DIAGNOSIS >

### B2267 ENGINE SPEED

#### Description

INFOID:000000006262156

The engine speed signal is transmitted from ECM to the combination meter via CAN communication.

#### DTC Logic

INFOID:000000006262157

#### DTC DETECTION LOGIC

DTC	Display contents of CONSULT-III	Diagnostic item is detected when ...	Probable malfunction location
B2267	ENGINE SPEED	ECM continuously transmits abnormal engine speed signals for 2 seconds or more	<ul style="list-style-type: none"><li>• Crankshaft position sensor (POS)</li><li>• ECM</li></ul>

#### Diagnosis Procedure

INFOID:000000006262158

##### 1. PERFORM SELF-DIAGNOSIS OF ECM

Perform "Self Diagnostic Result" of ECM, and repair or replace malfunctioning parts.

>> Refer to [EC-129, "CONSULT-III Function"](#).

# B2268 WATER TEMP

< DTC/CIRCUIT DIAGNOSIS >

## B2268 WATER TEMP

### Description

INFOID:000000006262159

The engine coolant temperature signal is transmitted from ECM to the combination meter via CAN communication.

### DTC Logic

INFOID:000000006262160

### DTC DETECTION LOGIC

DTC	Display contents of CONSULT-III	Diagnostic item is detected when ...	Probable malfunction location
B2268	WATER TEMP	ECM continuously transmits abnormal engine coolant temperature signals for 60 seconds or more	<ul style="list-style-type: none"><li>• Engine coolant temperature sensor</li><li>• ECM</li></ul>

### Diagnosis Procedure

INFOID:000000006262161

#### 1. PERFORM SELF-DIAGNOSIS OF ECM

Perform "Self Diagnosis Result" of ECM, and repair or replace malfunctioning parts.

>> Refer to [EC-129, "CONSULT-III Function"](#).

A  
B  
C  
D  
E  
F  
G  
H  
I  
J  
K  
L  
M  
O  
P

MWI

# POWER SUPPLY AND GROUND CIRCUIT

< DTC/CIRCUIT DIAGNOSIS >

## POWER SUPPLY AND GROUND CIRCUIT COMBINATION METER

### COMBINATION METER : Diagnosis Procedure

INFOID:000000006262162

#### 1. CHECK FUSE

Check for blown fuses.

Power source	Fuse No.
Battery	11
Ignition switch ON or START	4

Is the inspection result normal?

YES >> GO TO 2.

NO >> Be sure to eliminate cause of malfunction before installing new fuse.

#### 2. CHECK POWER SUPPLY CIRCUIT

Check voltage between combination meter harness connector terminals and ground.

Terminals		Ignition switch position	Voltage (Approx.)
(+)	(-)		
Combination meter		Ground	Battery voltage
Connector	Terminal		
M34	1		
	2		
		OFF	
		ON	

Is the inspection result normal?

YES >> GO TO 3.

NO >> Check harness between combination meter and fuse.

#### 3. CHECK GROUND CIRCUIT

1. Turn ignition switch OFF.
2. Disconnect combination meter connector.
3. Check continuity between combination meter harness connector terminals and ground.

Terminals		Continuity	
(+)	(-)		
Combination meter		Ground	Existed
Connector	Terminal		
M34	3		
	23		

Is the inspection result normal?

YES >> INSPECTION END

NO >> Repair harness or connector.

## IPDM E/R (INTELLIGENT POWER DISTRIBUTION MODULE ENGINE ROOM)

### IPDM E/R (INTELLIGENT POWER DISTRIBUTION MODULE ENGINE ROOM) : Diagnosis Procedure

INFOID:000000006845206

#### 1. CHECK FUSES AND FUSIBLE LINK

Check that the following IPDM E/R fuses or fusible links are not blown.

# POWER SUPPLY AND GROUND CIRCUIT

## < DTC/CIRCUIT DIAGNOSIS >

Signal name	Fuses and fusible link No.
Battery power supply	E
	50
	51

### Is the fuse fusing?

YES >> Replace the blown fuse or fusible link after repairing the affected circuit if a fuse or fusible link is blown.

NO >> GO TO 2.

## 2.CHECK POWER SUPPLY CIRCUIT

1. Turn the ignition switch OFF.
2. Disconnect IPDM E/R connector.
3. Check voltage between IPDM E/R harness connector and the ground.

Terminals		Voltage (Approx.)
(+)	(-)	
IPDM E/R		Battery voltage
Connector	Terminal	
E9	1	

### Is the measurement value normal?

YES >> GO TO 3.

NO >> Repair the harness or connector.

## 3.CHECK GROUND CIRCUIT

Check continuity between IPDM E/R harness connectors and the ground.

IPDM E/R		Ground	Continuity
Connector	Terminal		
E10	12		Existed
E11	41		

### Does continuity exist?

YES >> INSPECTION END

NO >> Repair the harness or connector.

A  
B  
C  
D  
E  
F  
G  
H  
I  
J  
K  
L  
M  
O  
P

MWI

# FUEL LEVEL SENSOR SIGNAL CIRCUIT

< DTC/CIRCUIT DIAGNOSIS >

## FUEL LEVEL SENSOR SIGNAL CIRCUIT

### Description

INFOID:000000006262164

The fuel level sensor unit and fuel pump (main) and the fuel level sensor unit (sub) detect the fuel level in the fuel tank and transmit the fuel gauge signal to the combination meter.

### Component Function Check

INFOID:000000006262165

#### 1.CHECK COMBINATION METER OUTPUT SIGNAL

Select the "Data Monitor" for the "METER/M&A" and compare the "FUEL METER" monitor value with the fuel gauge reading on the combination meter.

Fuel gauge pointer	Reference value of data monitor [lit.]
Full	Approx. 77.8
Three quarters	Approx. 63.0
Half	Approx. 42.5
A quarter	Approx. 22.0
Empty	Approx. 7.1

Does monitor value match fuel gauge reading?

- YES >> INSPECTION END
- NO >> Replace combination meter.

### Diagnosis Procedure

INFOID:000000006262166

#### 1.CHECK COMBINATION METER INPUT SIGNAL

1. Turn ignition switch ON.
2. Check voltage between combination meter harness connector terminal and ground.

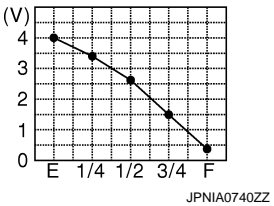
Terminals		Voltage (Approx.)
(+)	(-)	
Combination meter		 <p>JPNIA0740ZZ</p>
Terminal	Connector	
M34	34	
	Ground	

Does it match fuel gauge reading?

- YES >> GO TO 2.
- NO >> Replace the combination meter.

#### 2.CHECK FUEL LEVEL SENSOR CIRCUIT

1. Turn ignition switch OFF.
2. Disconnect combination meter connector and fuel level sensor unit (main) connector.
3. Check continuity between combination meter harness connector terminal and fuel level sensor unit (main) harness connector terminal.

# FUEL LEVEL SENSOR SIGNAL CIRCUIT

## < DTC/CIRCUIT DIAGNOSIS >

Terminals				Continuity
(+)		(-)		
Combination meter		Fuel level sensor unit (main)		
Connector	Terminal	Connector	Terminal	Existed
M34	34	B40	2	

4. Check continuity between combination meter harness connector terminal and ground.

Terminals				Continuity
(+)		(-)		
Combination meter		Ground		
Connector	Terminal			Not existed
M34	34			

Is the inspection result normal?

YES >> GO TO 3.

NO >> Repair harness or connector.

### 3.CHECK FUEL LEVEL SENSOR GROUND CIRCUIT

Check continuity between fuel level sensor unit (main) harness connector terminal and combination meter harness connector terminal.

Terminals				Continuity
(+)		(-)		
Fuel level sensor unit (main)		Combination meter		
Connector	Terminal	Connector	Terminal	Existed
B40	5	M34	24	

Is the inspection result normal?

YES >> INSPECTION END

NO >> Repair harness or connector.

### Component Inspection

INFOID:0000000006262167

#### 1.REMOVE FUEL LEVEL SENSOR UNIT

Remove the fuel level sensor unit. Refer to [FL-6, "Removal and Installation"](#).

>> GO TO 2.

#### 2.CHECK FUEL LEVEL SENSOR UNIT AND FUEL PUMP (MAIN)

Check the resistance between fuel level sensor unit and fuel pump (main).

Terminals		Condition	Resistance (Ω) (Approx.)	Height [mm (in)] (Approx.)
Fuel level sensor unit (main)				
5	6	Full (A)	2.5	193 (7.6)
		Empty (B)	81.5	15 (0.59)
2	7	—	0	—

Is the inspection result normal?

YES >> GO TO 3.

NO >> Replace fuel level sensor unit and fuel pump (main).

#### 3.CHECK FUEL LEVEL SENSOR UNIT (SUB)

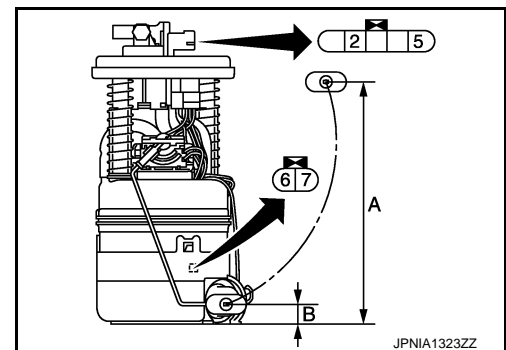

# FUEL LEVEL SENSOR SIGNAL CIRCUIT

## < DTC/CIRCUIT DIAGNOSIS >

Inspect the resistance of fuel level sensor unit (sub).

Terminals		Condi- tion	Resistance ( $\Omega$ ) (Approx.)	Height [mm (in)] (Approx.)
Fuel level sen- sor unit (sub)	(+)			
6	7	Full (A)	2.5	198 (7.8)
		Empty (B)	45.2	10 (0.39)

Is the inspection result normal?

YES >> INSPECTION END

NO >> Replace fuel level sensor unit (sub).

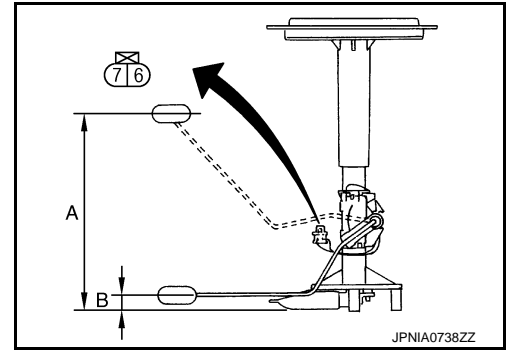



# METER CONTROL SWITCH SIGNAL CIRCUIT





< DTC/CIRCUIT DIAGNOSIS >

## METER CONTROL SWITCH SIGNAL CIRCUIT

### Description

INFOID:000000006262168

Transmits the following signals to the combination meter.





-  (illumination control) switch signal (+)
-  (illumination control) switch signal (-)
- Trip reset switch signal
-  (select) switch signal
-  (enter) switch is pressed

### Diagnosis Procedure

INFOID:000000006262169

#### 1. CHECK METER CONTROL SWITCH INPUT SIGNAL

1. Turn the ignition switch ON.
2. Check voltage between the following terminals of the combination meter.

Terminals				Condition	Voltage (Approx.)
Combination meter					
(+)		(-)			
Connector	Terminal	Connector	Terminal		
M34	12	M34	10	When  (select) switch is pressed	0 V
				Other than the above	5 V
	11			When  (enter) switch is pressed	0 V
				Other than the above	5 V
	8			When trip reset switch is pressed	0 V
				Other than the above	5 V
	14			When  (illumination control) switch is pressed	0 V
				Other than the above	5 V
13	When  (illumination control) switch is pressed	0 V			
	Other than the above	5 V			

Is the inspection result normal?

- YES >> INSPECTION END  
 NO >> GO TO 2.

#### 2. CHECK METER CONTROL SWITCH SIGNAL CIRCUIT

1. Turn the ignition switch OFF.
2. Disconnect the combination meter and meter control switch connectors.
3. Check continuity between combination meter harness connector terminals and meter control switch harness connector terminals.

MWI

# METER CONTROL SWITCH SIGNAL CIRCUIT

## < DTC/CIRCUIT DIAGNOSIS >

Terminals				Continuity
Combination meter		Meter control switch		
(+)		(-)		
Connector	Terminal	Connector	Terminal	Existed
M34	8	M83	11	
	10		5	
	11		12	
	12		1	
	13		6	
	14		4	

4. Check continuity between combination meter harness connector terminals and ground.

Terminals			Continuity
(+)		(-)	
Combination meter		Ground	Not existed
Connector	Terminal		
M34	8		
	10		
	11		
	12		
	13		
	14		

Is the inspection result normal?

YES >> INSPECTION END



NO >> Repair harness or connector.

## Component Inspection

INFOID:000000006262170

### 1. CHECK METER CONTROL SWITCH

1. Turn the ignition switch OFF.
2. Disconnect the meter control switch connector.
3. Check continuity between the following terminals of the meter control switch.

Terminal No.	Operation and status	Continuity
1	5 Press the ● (select) switch	Existed
	Other than the above	Not existed
12	5 Press the □ (enter) switch	Existed
	Other than the above	Not existed
11	5 Press the trip reset switch.	Existed
	Other than the above	Not existed
4	5 Press the  (illumination control) switch	Existed
	Other than the above	Not existed
6	5 Press the  (illumination control) switch	Existed
	Other than the above	Not existed

Is the inspection result normal?

YES >> INSPECTION END

# METER CONTROL SWITCH SIGNAL CIRCUIT

< DTC/CIRCUIT DIAGNOSIS >

---

NO >> Replace the meter control switch.

A

B

C

D

E

F

G

H

I

J

K

L

M

MWI

O

P

# OIL PRESSURE SWITCH SIGNAL CIRCUIT

< DTC/CIRCUIT DIAGNOSIS >

## OIL PRESSURE SWITCH SIGNAL CIRCUIT

### Description

INFOID:000000006262171

Detects the engine oil pressure and transmits the oil pressure switch signal to IPDM E/R.

### Component Function Check

INFOID:000000006262172

#### 1.CHECK COMBINATION METER INPUT SIGNAL

Select the "Data Monitor" for the "METER/M&A" and check the "OIL W/L" monitor value.

"OIL W/L"  
Ignition switch ON : On  
Engine running : Off

>> INSPECTION END

### Diagnosis Procedure

INFOID:000000006262173

#### 1.CHECK OIL PRESSURE SWITCH CIRCUIT

1. Turn ignition switch OFF.
2. Disconnect IPDM E/R connector and oil pressure switch connector.
3. Check continuity between IPDM E/R harness connector terminal and oil pressure switch harness connector terminal.

Terminals				Continuity
(+)		(-)		
IPDM E/R		Oil pressure switch		
Connector	Terminal	Connector	Terminal	
F12	75	F63	1	Existed

4. Check continuity between IPDM E/R harness connector terminal and ground.

Terminals			Continuity
(+)		(-)	
IPDM E/R		Ground	
Connector	Terminal		
F12	75		Not existed

Is the inspection result normal?

- YES >> INSPECTION END  
NO >> Repair harness or connector.

### Component Inspection

INFOID:000000006262174

#### 1.CHECK OIL PRESSURE SWITCH

# OIL PRESSURE SWITCH SIGNAL CIRCUIT

## < DTC/CIRCUIT DIAGNOSIS >

Check continuity between oil pressure switch and ground.

Condition	Continuity
Engine stopped	Existed
Engine running	Not existed

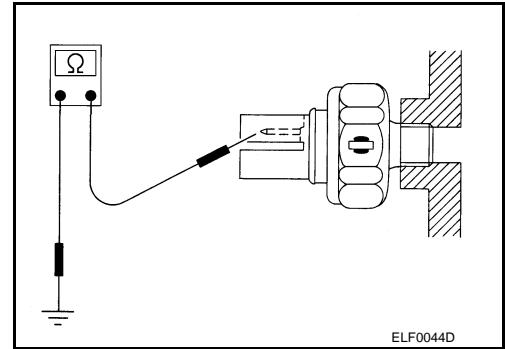

Is the inspection result normal?

YES >> INSPECTION END

NO >> Replace oil pressure switch. Refer to [EM-43, "Removal and Installation"](#).

A  
B  
C  
D  
E  
F  
G  
H  
I  
J  
K  
L  
M  
O  
P

MWI

# PARKING BRAKE SWITCH SIGNAL CIRCUIT

< DTC/CIRCUIT DIAGNOSIS >

## PARKING BRAKE SWITCH SIGNAL CIRCUIT

### Description

INFOID:000000006262175

Transmits the parking brake switch signal to the combination meter.

### Diagnosis Procedure

INFOID:000000006262176

#### 1. CHECK COMBINATION METER INPUT SIGNAL

1. Turn ignition switch ON.
2. Check the voltage between combination meter harness connector terminal and ground.

Terminals		Ground	Condition	Voltage (Approx.)
(+)	(-)			
Combination meter				
Connector	Terminal			
M34	26		When parking brake is applied	0 V
			When parking brake is released	5 V

Is the inspection result normal?

- YES >> INSPECTION END  
NO >> GO TO 2.

#### 2. CHECK PARKING BRAKE SWITCH SIGNAL CIRCUIT

1. Turn ignition switch OFF.
2. Disconnect combination meter connector and parking brake switch connector.
3. Check continuity between combination meter harness connector terminal and parking brake switch harness connector terminal.

Terminals				Continuity
(+) Combination meter		(-) Parking brake switch		
Connector	Terminal	Connector	Terminal	
M34	26	E27	1	Existed

4. Check continuity between combination meter harness connector terminal and ground.

Terminals		Ground	Continuity
(+)	(-)		
Combination meter			
Connector	Terminal		
M34	26		Not existed

Is the inspection result normal?

- YES >> INSPECTION END  
NO >> Repair harness or connector.

### Component Inspection

INFOID:000000006262177

#### 1. CHECK PARKING BRAKE SWITCH

Check parking brake switch. Refer to [BRC-88. "Component Inspection"](#).

Is the inspection result normal?

- YES >> INSPECTION END  
NO >> Replace parking brake switch.

# WASHER LEVEL SWITCH SIGNAL CIRCUIT

< DTC/CIRCUIT DIAGNOSIS >

## WASHER LEVEL SWITCH SIGNAL CIRCUIT

### Description

INFOID:000000006262178

Transmits the washer level switch signal to the combination meter.

### Diagnosis Procedure

INFOID:000000006262179

#### 1. CHECK WASHER LEVEL SWITCH SIGNAL CIRCUIT

1. Turn ignition switch OFF.
2. Disconnect combination meter connector and washer level switch connector.
3. Check continuity between combination meter harness connector terminal and washer level switch harness connector terminal.

Terminals				Continuity
Combination meter (+)		Washer level switch (-)		
Connector	Terminal	Connector	Terminal	
M34	29	E338	1	Existed

4. Check continuity between combination meter harness connector terminal and ground.

Terminals				Continuity
(+)		(-)		
Connector	Terminal	Ground		
M34	29			Not existed

Is the inspection result normal?

- YES >> INSPECTION END  
 NO >> Repair harness or connector.

### Component Inspection

INFOID:000000006262180

#### 1. CHECK WASHER LEVEL SWITCH

1. Turn ignition switch OFF.
2. Disconnect washer level switch connector.
3. Check washer level switch.

Terminals		Condition	Continuity
Washer level switch			
1	2	Washer level switch ON	Existed
		Washer level switch OFF	Not existed

Is the inspection result normal?

- YES >> INSPECTION END  
 NO >> Replace washer level switch. Refer to [WW-113. "Removal and Installation"](#).

A  
B  
C  
D  
E  
F  
G  
H  
I  
J  
K  
L  
M  
O  
P

MWI

# A/C AUTO AMP. CONNECTION RECOGNITION SIGNAL CIRCUIT

< DTC/CIRCUIT DIAGNOSIS >

## A/C AUTO AMP. CONNECTION RECOGNITION SIGNAL CIRCUIT

### Description

INFOID:000000006262181

A/C auto amp. transmit the A/C auto amp. connection recognition signal to the combination meter.

### Diagnosis Procedure

INFOID:000000006262182

#### 1. CHECK A/C AUTO AMP. CONNECTION RECOGNITION SIGNAL

1. Turn ignition switch ON.
2. Check voltage between combination meter harness connector terminal and ground.

Terminals		Voltage (Approx.)
(+)	(-)	
Combination meter		5 V
Connector	Terminal	
M34	19	

Is the inspection result normal?

YES >> INSPECTION END

NO >> GO TO 2.

#### 2. CHECK A/C AUTO AMP. CONNECTION RECOGNITION SIGNAL CIRCUIT

1. Turn ignition switch OFF.
2. Disconnect combination meter connector and A/C auto amp. connector.
3. Check continuity between combination meter harness connector terminal and A/C auto amp. harness connector terminal.

Combination meter		A/C auto amp.		Continuity
Connector	Terminal	Connector	terminal	
M34	19	M50	34	Existed

4. Check continuity between combination meter harness connector and ground.

Combination meter		Ground	Continuity
Connector	Terminal		
M34	19		Not existed

Is the inspection result normal?

YES >> INSPECTION END

NO >> Repair harness or connector.



# COMPASS

< DTC/CIRCUIT DIAGNOSIS >

## COMPASS

### Wiring Diagram - COMPASS -

INFOID:000000006262183

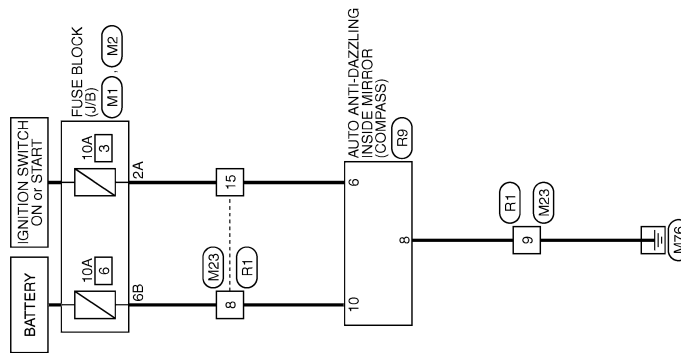

COMPASS

2010/09/06

JCNWM5352GB

A  
B  
C  
D  
E  
F  
G  
H  
I  
J  
K  
L  
M  
N  
O  
P

MWI

### COMPASS

Connector No.	M1
Connector Name	FUSE BLOCK (J/B)
Connector Type	NS06FW-MZ



Terminal No.	Color of Wire	Signal Name [Specification]
1A	Y	-
2A	G	-
3A	Y	-
4A	GR	-
5A	R	-
6A	W	-
7A	LG	-
8A	Y	-

Connector No.	M2
Connector Name	FUSE BLOCK (J/B)
Connector Type	NS10FW-CS



Terminal No.	Color of Wire	Signal Name [Specification]
1B	W	-
2B	L	-
3B	G	-
4B	L	-
5B	L	-
6B	Y	-
7B	R	-
8B	R	-
9B	GR	-

Connector No.	M23
Connector Name	WIRE TO WIRE
Connector Type	TH16MW-NH



Terminal No.	Color of Wire	Signal Name [Specification]
1	W	-
2	SHIELD	- [With navigation system] - [Without navigation system]
3	R	-
4	B	-
5	SHIELD	-
6	R	-
7	Y	-
8	Y	-
9	B	-
10	Y	-
11	P	-
12	L	-
13	SB	-
14	G	-
15	G	-
16	R	-

Connector No.	R1
Connector Name	WIRE TO WIRE
Connector Type	TH16FW-NH



Terminal No.	Color of Wire	Signal Name [Specification]
1	W	- [With navigation system] - [Without navigation system]
2	SHIELD	- [With navigation system] - [Without navigation system]
3	B	-
4	SHIELD	-
6	R/L	-

7	Y/R	-
8	B/Y	-
9	B	-
10	Y	-
11	P/W	-
12	B	-
13	R/Y	-
15	B/R	-
16	R	-

Connector No.	R9
Connector Name	AUTO ANTI-DIZZLING INSIDE MIRROR
Connector Type	TH10FB-NH

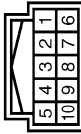

Terminal No.	Color of Wire	Signal Name [Specification]
6	B/R	-
8	B	-
10	B/Y	-

# COMBINATION METER

< ECU DIAGNOSIS INFORMATION >

## ECU DIAGNOSIS INFORMATION

### COMBINATION METER

Reference Value

INFOID:000000006262184

#### VALUES ON THE DIAGNOSIS TOOL

Monitor Item	Condition		Value/Status
SPEED METER [km/h]	Ignition switch ON	While driving	Equivalent to speedometer reading <b>NOTE:</b> 655.35 is displayed when the malfunction signal is received
SPEED OUTPUT [km/h]	Ignition switch ON	While driving	Equivalent to speedometer reading <b>NOTE:</b> 655.35 is displayed when the malfunction signal is received
ODO OUTPUT [km/h or mph]	Ignition switch ON	—	Equivalent to odometer reading in combination meter
TACHO METER [rpm]	Ignition switch ON	While driving	Equivalent to tachometer reading <b>NOTE:</b> 8191.875 is displayed when the malfunction signal is received
FUEL METER [L]	Ignition switch ON	—	Values according to fuel level
W TEMP METER [°C]	Ignition switch ON	—	Values according to engine coolant temperature <b>NOTE:</b> 215 is displayed when the malfunction signal is input
FUEL CAP W/L	Ignition switch ON	Fuel filler cap warning display ON	On
		Fuel filler cap warning display OFF	Off
ABS W/L	Ignition switch ON	ABS warning lamp ON	On
		ABS warning lamp OFF	Off
VDC/TCS IND	Ignition switch ON	VDC OFF indicator lamp ON	On
		VDC OFF indicator lamp OFF	Off
SLIP IND	Ignition switch ON	SLIP Indicator lamp ON	On
		SLIP indicator lamp OFF	Off
BRAKE W/L	Ignition switch ON	Brake warning lamp ON	On
		Brake warning lamp OFF	Off
DOOR W/L	Ignition switch ON	Door warning lamp ON	On
		Door warning lamp OFF	Off
HI-BEAM IND	Ignition switch ON	High-beam indicator lamp ON	On
		High-beam indicator lamp OFF	Off
TURN IND	Ignition switch ON	Turn signal indicator lamp ON	On
		Turn signal indicator lamp OFF	Off
LIGHT IND	Ignition switch ON	Light indicator lamp ON	On
		Light indicator lamp OFF	Off
OIL W/L	Ignition switch ON	Oil pressure warning lamp ON	On
		Oil pressure warning lamp OFF	Off
MIL	Ignition switch ON	Malfunction indicator lamp ON	On
		Malfunction indicator lamp OFF	Off



# COMBINATION METER

## < ECU DIAGNOSIS INFORMATION >

Monitor Item	Condition		Value/Status
CRUISE IND	Ignition switch ON	CRUISE indicator lamp ON	On
		CRUISE indicator lamp OFF	Off
O/D OFF IND	Ignition switch ON	O/D OFF indicator lamp ON	On
		O/D OFF indicator lamp OFF	Off
4WD W/L	Ignition switch ON	AWD warning lamp ON	On
		AWD warning lamp OFF	Off
4WD LOCK IND	Ignition switch ON	AWD LOCK indicator lamp ON	On
		AWD LOCK indicator lamp OFF	Off
FUEL W/L	Ignition switch ON	Low-fuel warning lamp ON	On
		Low-fuel warning lamp OFF	Off
WASHER W/L	Ignition switch ON	Washer warning displayed	On
		Washer warning not displayed	Off
AIR PRES W/L	Ignition switch ON	Low tire pressure lamp ON	On
		Low tire pressure lamp OFF	Off
KEY G/Y W/L	Ignition switch ON	Key warning lamp (green/yellow) ON	On
		Key warning lamp (green/yellow) OFF	Off
LCD	Ignition switch ON	Engine start information display	B&P I
	Ignition switch ACC	Engine start information display	B&P N
	Ignition switch LOCK	Key ID warning display	ID NG
	Ignition switch LOCK	Steering lock information display	ROTAT
	Ignition switch LOCK	P position warning display	SFT P
	Ignition switch LOCK	Intelligent Key insert information display	INSRT
	Ignition switch LOCK	Intelligent Key low battery warning display	BATT
	Ignition switch ON	Take away warning display	NO KY
	Ignition switch LOCK	Key warning display	OUTKY
	Ignition switch ON	ACC warning display	LK WN
SHIFT IND	Ignition switch ON	Shift position indicator P display	P
		Shift position indicator R display	R
		Shift position indicator N display	N
		Shift position indicator D display	D
		Shift position indicator L display	L
O/D OFF SW	Ignition switch ON	Overdrive control switch ON	On
		Overdrive control switch OFF	Off
M RANGE SW	Ignition switch ON	<b>NOTE:</b> This item is displayed, but cannot be monitored.	Off
NM RANGE SW	Ignition switch ON	<b>NOTE:</b> This item is displayed, but cannot be monitored.	Off

# COMBINATION METER

## < ECU DIAGNOSIS INFORMATION >

Monitor Item	Condition		Value/Status
AT SFT UP SW	Ignition switch ON	<b>NOTE:</b> This item is displayed, but cannot be monitored.	Off
AT SFT DWN SW	Ignition switch ON	<b>NOTE:</b> This item is displayed, but cannot be monitored.	Off
ST SFT UP SW	Ignition switch ON	<b>NOTE:</b> This item is displayed, but cannot be monitored.	Off
ST SFT DWN SW	Ignition switch ON	<b>NOTE:</b> This item is displayed, but cannot be monitored.	Off
PKB SW	Ignition switch ON	Parking brake switch ON	On
		Parking brake switch OFF	Off
BUCKLE SW	Ignition switch ON	Seat belt (driver side) not fastened	On
		Seat belt (driver side) fastened	Off
BRAKE OIL SW	Ignition switch ON	Brake fluid level switch ON	On
		Brake fluid level switch OFF	Off
DISTANCE [km]	Ignition switch ON	—	Possible driving distance calculated by combination meter
A/C AMP CONN	Ignition switch ON	Other than the following	On
		Receives ambient sensor power signal	Off
ENTER SW	Ignition switch ON	When  is pressed	On
		Other than the above	Off
SELECT SW	Ignition switch ON	When  is pressed	On
		Other than the above	Off
OUTSIDE TEMP [°C] or [°F]	Ignition switch ON	—	Equivalent to ambient temperature <b>NOTE:</b> This may not match the indicated value on the information display.
FUEL LOW SIG	Ignition switch ON	Low fuel warning displayed	On
		Low fuel warning not displayed	Off
BUZZER	Ignition switch ON	Buzzer ON	On
		Buzzer OFF	Off

**NOTE:**

Some items are not available according to vehicle specification.

## TERMINAL LAYOUT

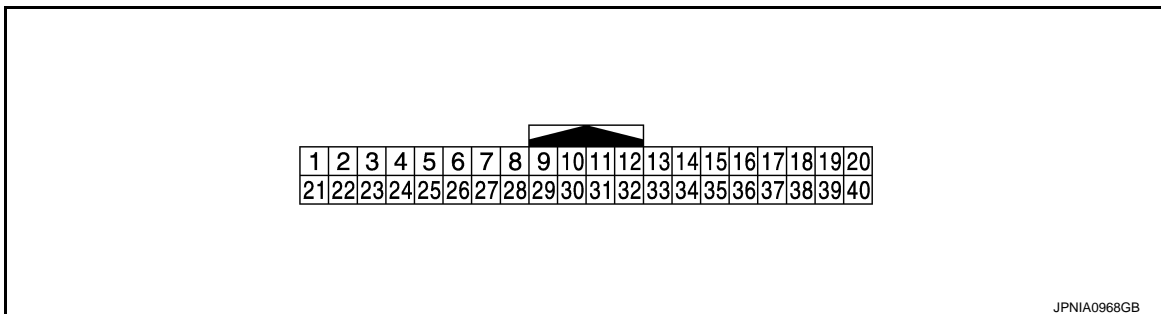





## PHYSICAL VALUES

A  
B  
C  
D  
E  
F  
G  
H  
I  
J  
K  
L  
M  
N  
O  
P

MWI

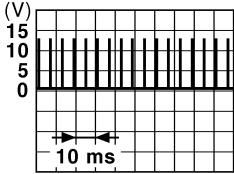
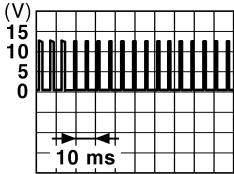
# COMBINATION METER

## < ECU DIAGNOSIS INFORMATION >

Terminal No. (Wire color)		Description		Condition		Value (Approx.)
+	-	Signal name	Input/ Output			
1 (Y)	Ground	Battery power supply	Input	Ignition switch OFF	—	Battery voltage
2 (O)	Ground	IGN signal	Input	Ignition switch ON	—	Battery voltage
3 (B)	Ground	Ground	—	Ignition switch ON	—	0 V
5 (SB)	Ground	Illumination control signal	Output	Ignition switch ON	<ul style="list-style-type: none"> <li>• Lighting switch 1ST</li> <li>• When meter illumination is maximum</li> </ul>	 <p style="text-align: right; font-size: small;">JPNIA0828GB</p>
					<ul style="list-style-type: none"> <li>• Lighting switch 1ST</li> <li>• When meter illumination is minimum</li> </ul>	 <p style="text-align: right; font-size: small;">JPNIA0827GB</p>
8 (SB)	10 (O)	Trip reset signal	Input	Ignition switch ON	When trip reset switch is pressed.	0 V
					Other than the above	5 V
10 (O)	Ground	Meter control switch ground	—	Ignition switch ON	—	0 V
11 (L)	10 (O)	Enter switch signal	Input	Ignition switch ON	When  is pressed.	0 V
					Other than the above	5 V
12 (R)	10 (O)	Select switch signal	Input	Ignition switch ON	When  is pressed.	0 V
					Other than the above	5 V
13 (Y*1 or V*2)	10 (O)	Illumination control switch signal (+)	Input	Ignition switch ON	When  is pressed.	0 V
					Other than the above	5 V
14 (GR)	10 (O)	Illumination control switch signal (-)	Input	Ignition switch ON	When  is pressed.	0 V
					Other than the above	5 V
15 (BR)	Ground	Air bag signal	Input	Ignition switch ON	Air bag warning lamp ON	4 V
					Air bag warning lamp OFF	0 V

# COMBINATION METER

## < ECU DIAGNOSIS INFORMATION >

Terminal No. (Wire color)		Description		Condition		Value (Approx.)
+	-	Signal name	Input/ Output			
18 (L)	Ground	Ambient sensor signal	Input	Ignition switch ON	Changes depending to am- bient temperature.	<p style="text-align: right; font-size: small;">JSNIA0014GB</p>
19 (P)	Ground	Ambient sensor power	Input	Ignition switch ON	—	5 V
20 (Y)	Ground	Ambient sensor ground	Input	Ignition switch ON	—	0 V
21 (L)	—	CAN-H	—	—	—	—
22 (P)	—	CAN-L	—	—	—	—
23 (B)	Ground	Ground	—	Ignition switch ON	—	0 V
24 (W)	Ground	Fuel level sensor signal ground	—	Ignition switch ON	—	0 V
25 (BR)	Ground	Alternator signal	Input	Ignition switch ON	Charge warning lamp ON	2 V
					Charge warning lamp OFF	12 V
26 (G)	Ground	Parking brake switch signal	Input	Ignition switch ON	Parking brake ON	0 V
					Parking brake OFF	5 V
27 (V)	Ground	Brake fluid level switch sig- nal	Input	Ignition switch ON	Brake fluid level is normal	12 V
					Brake fluid level is less than LOW level	0 V
29 (R)	Ground	Washer level switch signal	Input	Ignition switch ON	Washer level switch ON	0 V
					Washer level switch OFF	5 V
30 (P)	Ground	Vehicle speed signal output (2-pulse)	Output	Ignition switch ON	Speedometer operated [When vehicle speed is approx. 40 km/h (25 MPH)]	<p><b>NOTE:</b> The maximum voltage varies de- pending on the specification (destination unit).</p> <p style="text-align: right; font-size: small;">JSNIA0015GB</p>

A  
B  
C  
D  
E  
F  
G  
H  
I  
J  
K  
L  
M  
O  
P

MWI

# COMBINATION METER

## < ECU DIAGNOSIS INFORMATION >

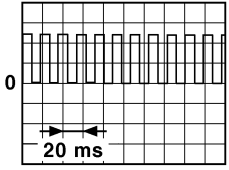
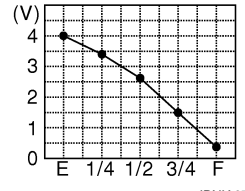
Terminal No. (Wire color)		Description		Condition	Value (Approx.)	
+	-	Signal name	Input/ Output			
31 (V)	Ground	Vehicle speed signal output (8-pulse)	Output	Ignition switch ON	Speedometer operated [When vehicle speed is approx. 40 km/h (25 MPH)]	
<p><b>NOTE:</b> The maximum voltage varies depending on the specification (destination unit).</p>  <p style="text-align: right; font-size: small;">JPNIA0012GB</p>						
32 (LG)	Ground	Overdrive control switch signal	Input	Ignition switch ON	Overdrive control switch pressed.	0 V
					Overdrive control switch not pressed.	12 V
34 (G)	Ground	Fuel level sensor signal	Input	Ignition switch ON	—	
 <p style="text-align: right; font-size: small;">JPNIA0740ZZ</p>						
35 (SB)	Ground	Seat belt buckle switch sig- nal (driver side)	Input	Ignition switch ON	When driver seat belt is fas- tened.	12 V
					When driver seat belt is un- fastened.	0 V
36 (R)	Ground	Seat belt buckle switch sig- nal (passenger side)	Input	Ignition switch ON	<ul style="list-style-type: none"> <li>• When getting in the pas- senger seat.</li> <li>• When passenger seat belt is fastened.</li> </ul>	12 V
					<ul style="list-style-type: none"> <li>• When getting in the pas- senger seat.</li> <li>• When passenger seat belt is unfastened.</li> </ul>	0 V

\*1: Without automatic drive positioner

\*2: With automatic drive positioner



# COMBINATION METER

< ECU DIAGNOSIS INFORMATION >

## Wiring Diagram - METER -

INFOID:000000006262185

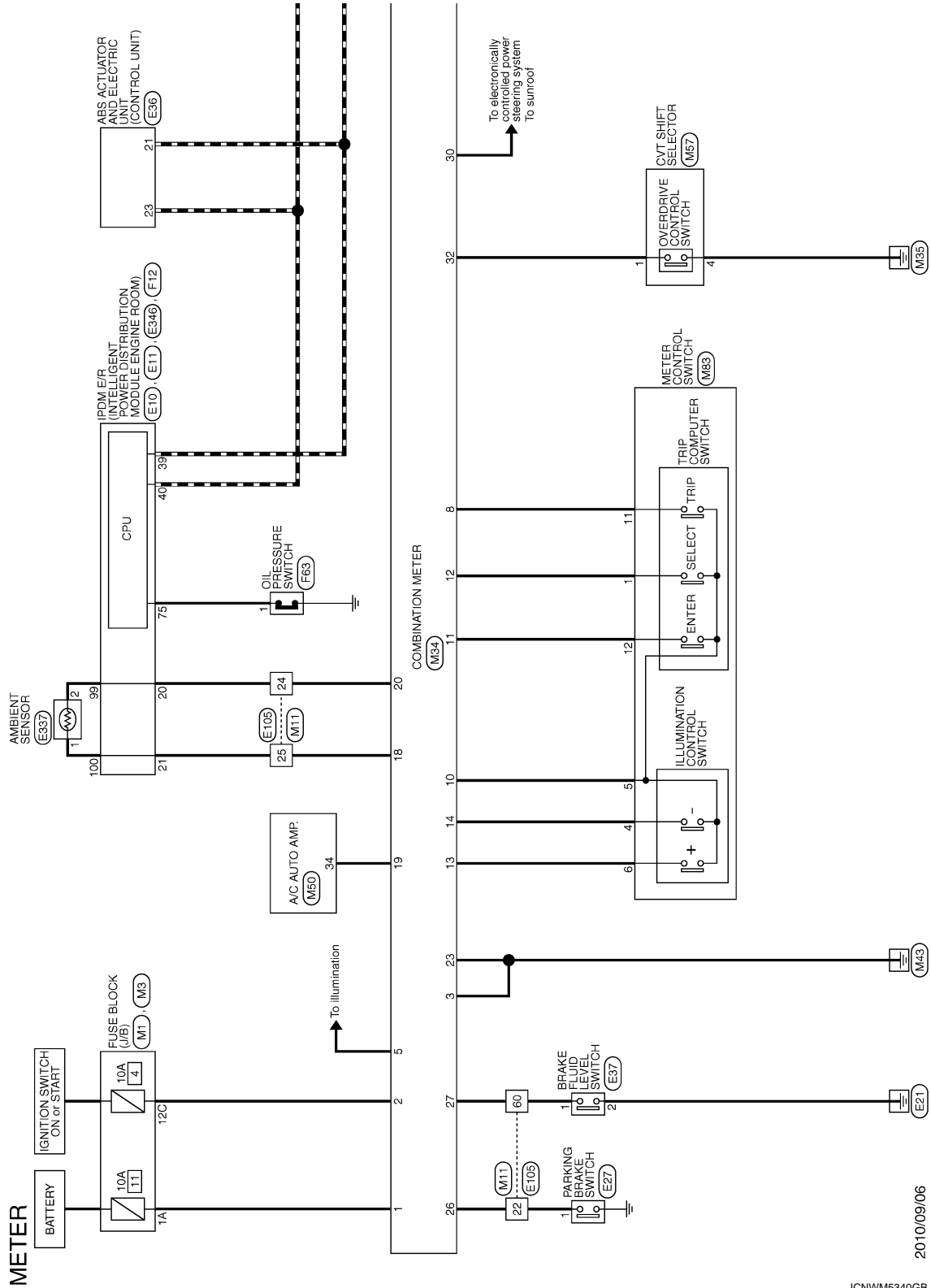

2010/09/06

JCNWM5340GB

A  
B  
C  
D  
E  
F  
G  
H  
I  
J  
K  
L  
M  
N  
O  
P

MWI

# COMBINATION METER

< ECU DIAGNOSIS INFORMATION >

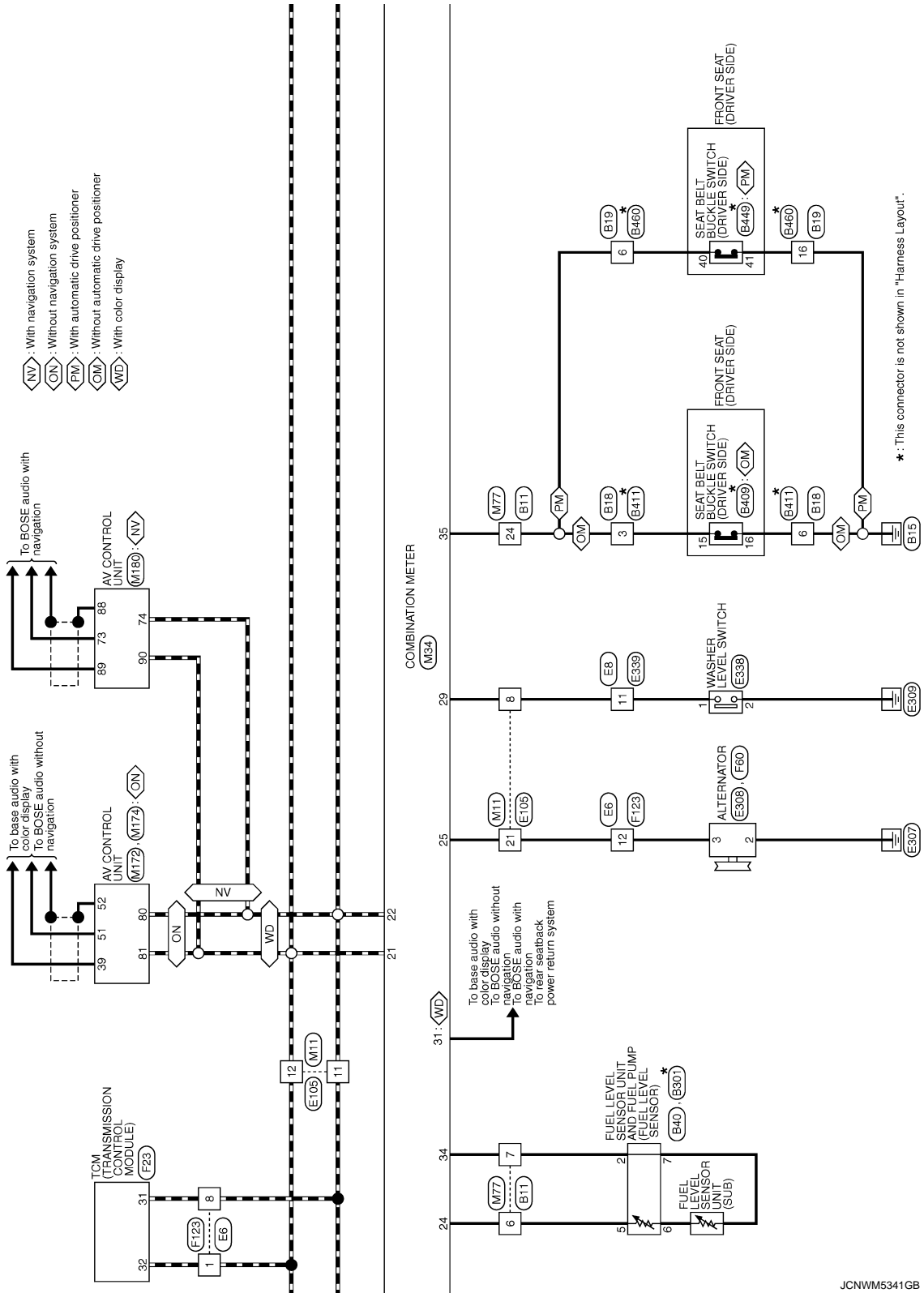

JCNWM5341 GB

# COMBINATION METER

< ECU DIAGNOSIS INFORMATION >

◁AW▷ : AWD models  
 ◁AB▷ : With automatic back door  
 ◁OA▷ : Without automatic back door

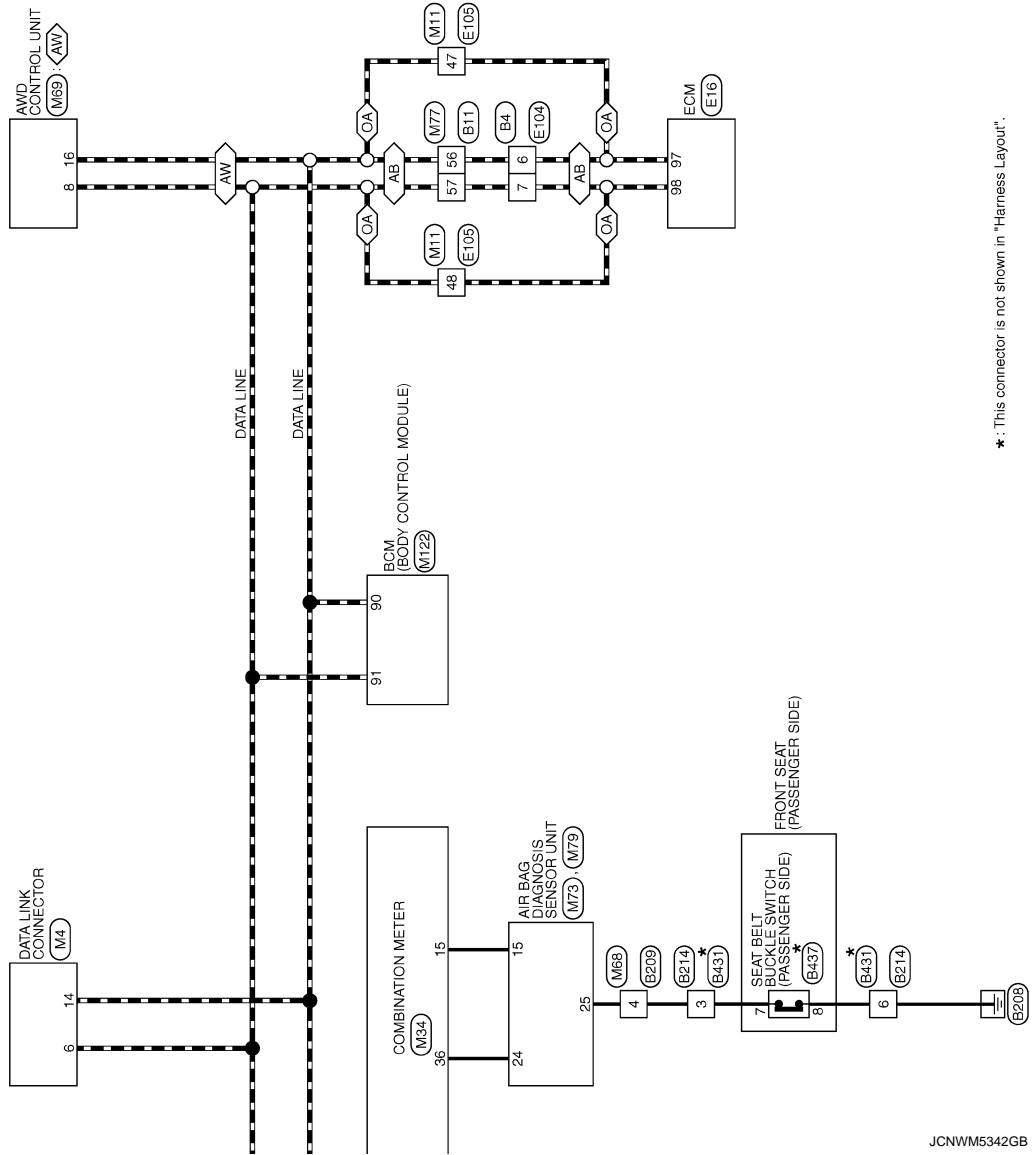

\* : This connector is not shown in "Harness Layout".

JCNWM5342GB

A  
B  
C  
D  
E  
F  
G  
H  
I  
J  
K  
L  
M  
N  
O  
P

MWI

# COMBINATION METER

< ECU DIAGNOSIS INFORMATION >

## METER

Connector No.	B4
Connector Name	WIRE TO WIRE
Connector Type	NS16MW-CS



1	2	3	4	5	6	7		
8	9	10	11	12	13	14	15	16

Terminal No.	Color of Wire	Signal Name [Specification]
1	SB	-
2	W	-
3	W	-
4	R	-
5	O	-
6	P	-
7	L	-
8	B	-
9	LG	-
10	Y	-
11	L	-
12	BR	-
13	P	-
14	BR	-
15	O	-
16	G	-

Connector No.	B11
Connector Name	WIRE TO WIRE
Connector Type	TH80MW-CS19



Terminal No.	Color of Wire	Signal Name [Specification]
1	SHIELD	-
2	B	-
3	R/L	-
4	R/W	-
5	SB	-
6	P	-

7	V	-
8	SHIELD	-
9	R/L	-
10	Y/G	-
11	Y/L	-
12	W/L	-
13	L	-
14	BR	-
15	SB	-
16	BR	-
17	V	-
18	SB	-
19	R	-
20	P	-
21	LG	-
22	W	-
23	Y	-
24	GR	-
25	Y	-
26	W/L	-
27	V	-
28	W/L	-
29	P	-
30	P	-
31	O	-
32	BR	-
33	BR	-
34	SB	-
35	SHIELD	-
36	L/O	-
37	LG	-
40	Y	-
41	GR	-
42	SB	-
46	LG	-
47	SB	-
48	SHIELD	-
49	B	-
50	R/W	-
51	R/L	-
52	B	-
53	Y	-
54	LG	-
55	BR	-
56	P	-
57	L	-
58	R	-
59	SHIELD	-
60	B	-
61	R/L	-
62	R/W	-
63	LG	-
64	Y	-
65	BR	-
66	V	-

67	GR	-
68	R	-
69	SHIELD	-
70	W/R	-
71	B/R	-
72	Y	-
73	LG	-
74	SB	-
75	L	-
76	G	-
77	R	-
79	B	-
80	W	-
81	R	-
82	L	-
83	BR	-
84	O	-
85	G	-
86	SB	-
87	R	-
88	G	-
89	GR	-
90	Y	-
91	G	-
92	BR	-
93	G	-
94	V	-
95	BR	-
96	GR	-
97	R	-
98	LG	-
99	O	-

Connector No.	B18
Connector Name	WIRE TO WIRE
Connector Type	NS80FW-CS



1	2		
3	4	5	6

Terminal No.	Color of Wire	Signal Name [Specification]
1	BR	-
2	B	-
3	GR	-
4	O	-

5	G	-
6	B/W	-

Connector No.	B19
Connector Name	WIRE TO WIRE
Connector Type	NS18FW-CS



1	2	3	4					
8	9	10	11	12	13	14	15	16

Terminal No.	Color of Wire	Signal Name [Specification]
1	BR	-
2	L	-
3	W	-
4	P	-
5	V	-
6	GR	-
7	B	-
8	Y	-
9	P	-
10	LG	-
11	R	-
12	SB	-
13	O	-
14	BR	-
15	G	-
16	B/W	-

# COMBINATION METER

< ECU DIAGNOSIS INFORMATION >

## METER

Connector No.	B40
Connector Name	FUEL LEVEL SENSOR UNIT AND FUEL PUMP
Connector Type	ESFCY-RS



Terminal No.	Color of Wire	Signal Name [Specification]
1	W	-
2	V	-
3	B	-
4	SB	-
5	P	-

Connector No.	B209
Connector Name	WIRE TO WIRE
Connector Type	TK12MG-Y-BD

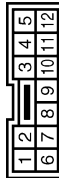

Terminal No.	Color of Wire	Signal Name [Specification]
1	R	-
2	W	-
3	L	-
4	BR	-
5	Y	-
6	G	-
7	SHIELD	-
8	LG	-
9	P	-
11	SB	-

Connector No.	B214
Connector Name	WIRE TO WIRE
Connector Type	NSGFFI-CS



Terminal No.	Color of Wire	Signal Name [Specification]
1	O	-
2	B	-
3	BR	-
4	GR	-
5	G	-
6	B/W	-

Connector No.	B301
Connector Name	FUEL LEVEL SENSOR UNIT AND FUEL PUMP
Connector Type	-



Terminal No.	Color of Wire	Signal Name [Specification]
6	-	-
7	-	-

Connector No.	B408
Connector Name	SEAT BELT BUCKLE SWITCH (DRIVER SIDE)
Connector Type	A03MW-P

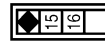

Terminal No.	Color of Wire	Signal Name [Specification]
15	W/G	-
18	GR	-

Connector No.	B411
Connector Name	WIRE TO WIRE
Connector Type	NS08MW-CS

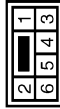

Terminal No.	Color of Wire	Signal Name [Specification]
1	R	-
2	B	-
3	W/G	-
4	GR	-
5	B/R	-
6	GR	-

Connector No.	B431
Connector Name	WIRE TO WIRE
Connector Type	NS08MW-CS

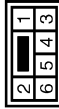

Terminal No.	Color of Wire	Signal Name [Specification]
1	R	-
2	B	-
3	W/G	-
4	W/R	-
5	B/R	-
6	GR	-

Connector No.	B437
Connector Name	SEAT BELT BUCKLE SWITCH (PASSENGER SIDE)
Connector Type	A03MW-P

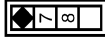

Terminal No.	Color of Wire	Signal Name [Specification]
7	W/G	-
8	GR	-

Connector No.	B449
Connector Name	SEAT BELT BUCKLE SWITCH (DRIVER SIDE)
Connector Type	A03MW-P



Terminal No.	Color of Wire	Signal Name [Specification]
40	W/G	-
41	GR	-

A  
B  
C  
D  
E  
F  
G  
H  
I  
J  
K  
L  
M  
N  
O  
P

MWI

JCNWM5344GB

# COMBINATION METER

< ECU DIAGNOSIS INFORMATION >

## METER

Connector No.	B460
Connector Name	WIRE TO WIRE
Connector Type	NS16MW-CS



7	6	5	4	3	2	1		
16	15	14	13	12	11	10	9	8

Terminal No.	Color of Wire	Signal Name [Specification]
1	R	-
2	P	-
3	G/O	-
4	O/L	-
5	BR	-
6	W/G	-
7	B	-
8	W/L	-
9	P/L	-
10	L/O	-
11	V	-
12	V/W	-
13	W/R	-
14	BR/W	-
15	B/R	-
16	GR	-

Connector No.	E6
Connector Name	WIRE TO WIRE
Connector Type	TK16MGY-1V



1	2	3	4	5	6	7		
8	9	10	11	12	13	14	15	16

Terminal No.	Color of Wire	Signal Name [Specification]
1	L	-
3	Y	-
4	R	-
5	GR	-
6	V	-
8	P	-

10	W	-	19	Y	-
11	G	-	20	L	-
12	BR	-	21	O	-
13	SB	-	22	SB	-
14	B	-	23	GR	-
			24	G	-
			25	GR	-
			26	Y	-
			27	W	-
			28	SB	-
			30	BR	-
			34	O	-
			35	P	-
			36	G	-
			38	GR	-

Connector No.	E8
Connector Name	WIRE TO WIRE
Connector Type	NS12MBR-CS



1	2	3	4	5		
6	7	8	9	10	11	12

Terminal No.	Color of Wire	Signal Name [Specification]
3	GR	-
4	SB	-
5	O	-
8	G	-
9	W	-
10	Y	-
11	G	-

Connector No.	E10
Connector Name	ENGINE ROOM INTELLIGENT POWER DISTRIBUTION MODULE
Connector Type	TH20FW-CS12-M4-1V



9	10	11	12	13	14	15	16	17	18	19	20	21	22	23	24	25	26	27	28	29	30						
3	4	5	6	7	8	9	10	11	12	13	14	15	16	17	18	19	20	21	22	23	24	25	26	27	28	29	30

Terminal No.	Color of Wire	Signal Name [Specification]
4	LG	-
5	Y	-
7	GR	-
10	BR	-
12	B	-
13	SB	-
15	W	-
16	R	-

19	Y	-	28	Y	-
20	L	-	29	G	-
21	O	-	30	BR	-
22	SB	-	34	O	-
23	GR	-	35	P	-
24	G	-	36	G	-
25	GR	-	38	GR	-
26	Y	-			
27	W	-			
28	SB	-			
30	BR	-			
34	O	-			
35	P	-			
36	G	-			
38	GR	-			

Connector No.	E11
Connector Name	ENGINE ROOM INTELLIGENT POWER DISTRIBUTION MODULE
Connector Type	TH20FW-NH



42	41	40	39
46	45	44	43

Terminal No.	Color of Wire	Signal Name [Specification]
39	P	-
40	L	-
41	B	-
42	SB	-
43	Y	-
44	W	-
45	O	-
46	BR	-

Connector No.	E16
Connector Name	ECM
Connector Type	RN24FB-R28-L-LH



81	85	89	93	97	101	105	109
82	86	90	94	98	102	106	110
83	87	91	95	99	103	107	111
84	88	92	96	100	104	108	112

Terminal No.	Color of Wire	Signal Name [Specification]
81	W	ACCELERATOR PEDAL POSITION SENSOR 1
82	O	ACCELERATOR PEDAL POSITION SENSOR 2
83	BR	SENSOR POWER SUPPLY
84	B	SENSOR GROUND
85	Y	ASC/D STEERING SWITCH
86	SB	EVAP CONTROL SYSTEM PRESSURE SENSOR
87	GR	SENSOR POWER SUPPLY
88	O	DATA LINK CONNECTOR
91	L	SENSOR POWER SUPPLY
92	BR	SENSOR GROUND
93	BR	IGNITION SWITCH
94	GR	ENGINE SPEED OUTPUT SIGNAL
95	Y	FUEL TANK TEMPERATURE SENSOR
96	GR	SENSOR GROUND
97	P	CAN COMMUNICATION LINE(CAN-L)
98	L	CAN COMMUNICATION LINE(CAN-H)
100	G	SENSOR GROUND
102	R	PNP SIGNAL
104	SB	SENSOR GROUND
105	V	POWER SUPPLY FOR ECM
106	SB	STOP LAMP SWITCH
107	B	ECM GROUND
108	B	ECM GROUND
109	W	EVAP CANISTER VENT CONTROL VALVE
110	G	ASC/D BRAKE SWITCH
111	B	ECM GROUND
112	B	ECM GROUND

# COMBINATION METER

< ECU DIAGNOSIS INFORMATION >

## METER

Connector No.	E27
Connector Name	PARKING BRAKE SWITCH
Connector Type	PO1E-A



Terminal No.	1	P	Signal Name [Specification]	-
--------------	---	---	-----------------------------	---

Connector No.	E16
Connector Name	ABS ACTUATOR AND ELECTRIC UNIT (CONTROL UNIT)
Connector Type	AE2ZF6-AJ24-LH

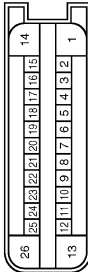

Terminal No.	Color of Wire	Signal Name [Specification]
1	R	VALVE / ECU SUPPLY
2	Y	WSS RL SIG (-)
3	L	WSS RL PWR (+)
4	GR	CLUSTER SUPPLY
5	B	WSS FR PWR (+)
6	W	WSS FR SIG (-)
7	LG	LIS
8	V	WSS FL SIG (-)
9	W	WSS FL PWR (+)
10	SB	CLUSTER GND
11	P	WSS RR PWR (+)
12	V	WSS RR SIG (-)
13	B/W	MOTOR GND
14	G	MOTOR SUPPLY
16	SB	BLS
19	BR	CAN 2 H
20	GR	IGN
21	P	CAN 1 L
22	Y	VDC OFF SW
23	L	CAN 1 H
25	W	CAN 2 L

26	B/W	VALVE / ECU GND
----	-----	-----------------

Connector No.	E37
Connector Name	BRAKE FLUID LEVEL SWITCH
Connector Type	YY02FGY



Terminal No.	Color of Wire	Signal Name [Specification]
1	P	-
2	B	-

Connector No.	E104
Connector Name	WIRE TO WIRE
Connector Type	NS16FW-OS



Terminal No.	Color of Wire	Signal Name [Specification]
1	Y	-
2	SB	-
3	L	-
4	R	-
5	L	-
6	P	-
7	L	-
8	B/W	-
9	SB	-
10	GR	-
11	R	-
12	W	-
13	P	-
14	V	-
15	Y	-
16	L	-

Connector No.	E105
Connector Name	WIRE TO WIRE
Connector Type	TH12MW-CS1.0-M3



Terminal No.	Color of Wire	Signal Name [Specification]
3	Y	-
5	LG	-
6	GR	-
8	G	-
11	P	-
12	L	-
13	Y	-
14	O	-
15	BR	-
20	Y	-
21	BR	-
22	P	-
24	L	-
25	O	-
28	SB	-
29	W	-
30	Y	-
47	P	-
48	L	-
49	SB	-
50	GR	-
51	LG	-
52	V	-
53	GR	-
54	BR	-
55	Y	-
56	W/L	-
60	V	-
61	BR	-
62	O	-
63	L/O	-
64	SHIELD	-
66	W	-
67	BR	-
68	Y	-
69	SB	-
70	GR	-
71	SB	-

72	Y	-
73	L	-
74	W	-
75	BR	-
76	GR	-
77	O	-
78	Y	-
78	G	- [With navigation system]
78	V	- [With iPod without navigation system]
78	V	- [Without iPod and navigation system]
79	Y	-
80	R	-
81	W	-
82	LG	-
83	O	-

Connector No.	E308
Connector Name	ALTERNATOR
Connector Type	-



Terminal No.	Color of Wire	Signal Name [Specification]
2	B	-

Connector No.	E337
Connector Name	AMBIENT SENSOR
Connector Type	RS32FB



Terminal No.	Color of Wire	Signal Name [Specification]
1	SB	-
2	BR	-

A  
B  
C  
D  
E  
F  
G  
H  
I  
J  
K  
L  
M  
N  
O  
P

MWI

# COMBINATION METER

< ECU DIAGNOSIS INFORMATION >

## METER

Connector No.	E338
Connector Name	WASHER LEVEL SWITCH
Connector Type	Z02PBR



Terminal No.	Color of Wire	Signal Name [Specification]
1	R	
2	B	

Connector No.	E339
Connector Name	WIRE TO WIRE
Connector Type	NS12PBR-CS

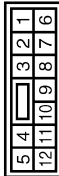

Terminal No.	Color of Wire	Signal Name [Specification]
3	O	
4	G	
5	O	
8	G	
9	W	
10	Y	
11	R	

Connector No.	E346
Connector Name	ENGINE INTELLIGENT POWER DISTRIBUTION MODULE (ENGINE ROOM)
Connector Type	TH16FW-NH

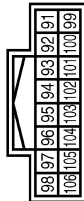

Terminal No.	Color of Wire	Signal Name [Specification]
91	R	
99	LG	
100	SB	
101	L	
102	B	
103	P	

Connector No.	F12
Connector Name	ENGINE INTELLIGENT POWER DISTRIBUTION MODULE (ENGINE ROOM)
Connector Type	TH20PW-OS12-M4



Terminal No.	Color of Wire	Signal Name [Specification]
48	W	
49	R/B	
51	LG	
52	Y/G	
53	R/W	
54	G/W	
55	W/L	
56	R/Y	
57	O	
58	Y	
69	W/B	
70	O	
72	R/B	
75	LG	
76	SB	

77	GR	-
80	B	-

Connector No.	F23
Connector Name	TCA (TRANSMISSION CONTROL MODULE)
Connector Type	RH40FB-R2B-LRH

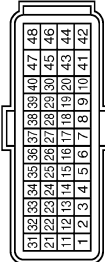

Terminal No.	Color of Wire	Signal Name [Specification]
1	P/B	INH SW 2
2	P/L	INH SW 3
3	G/D	INH SW 4
4	GR	INH SW 3 MON
5	B	GND
7	W	SENSOR GND
8	G/W	CLOCK (SEL 2)
9	L/R	CHIP SELECT (SEL 1)
10	BR/R	DATA I/O (SEL 3)
11	BR/W	INH SW 1
13	V	ATF TEMP SENSOR
14	R/W	PRI PRESS SENSOR
15	V/W	SEC PRESS SENSOR
19	G/B	REV LAMP RELAY
20	R/B	STARTER RELAY
25	W/R	SENSOR GND
26	L/O	SENSOR POWER SOURCE (BV)
27	R/G	S/M-D
28	R	S/M-C
29	O/B	S/M-B
30	G/R	S/M-A
31	P	CAN-L
32	L	CAN-H
33	LG	PRI SPEED SENSOR
34	LG/R	SEC SPEED SENSOR
37	V/R	L/U & SEL-ON/OFF SOL
38	L/W	L/U & SEL-LINEAR SOL
39	W/B	SEC-LINEAR SOL
40	R/Y	PL-LINEAR SOL
42	B	GND
46	Y	VIGN
47	L/R	BATT
48	Y	VIGN

Connector No.	F60
Connector Name	ALTERNATOR
Connector Type	HS30ZFB



Terminal No.	Color of Wire	Signal Name [Specification]
3	BR	
4	Y/B	
5	SB	

Connector No.	F63
Connector Name	OIL PRESSURE SWITCH
Connector Type	ED1FGY-RS-AR



Terminal No.	Color of Wire	Signal Name [Specification]
1	LG	

JCNWM5347GB



# COMBINATION METER

< ECU DIAGNOSIS INFORMATION >

## METER

Connector No.	F123
Connector Name	WIRE TO WIRE
Connector Type	TK16GY-IV

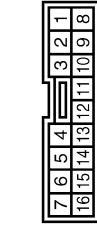

Terminal No.	Color of Wire	Signal Name [Specification]
1	L	-
3	G/R	-
4	G/B	-
5	R	-
6	L/R	-
8	P	-
10	Y/B	-
11	BR/W	-
12	BR	-
13	G	-
14	B	-

Connector No.	M1
Connector Name	FUSE BLOCK (J/B)
Connector Type	NS08FW-AM2

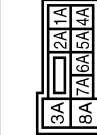

Terminal No.	Color of Wire	Signal Name [Specification]
1A	Y	-
2A	G	-
3A	Y	-
4A	GR	-
5A	R	-
6A	W	-
7A	LG	-
8A	Y	-

Connector No.	M3
Connector Name	FUSE BLOCK (J/B)
Connector Type	NS12FT-CS

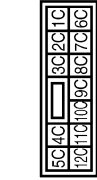

Terminal No.	Color of Wire	Signal Name [Specification]
6C	BR	-
7C	B	-
8C	G	-
9C	GR	-
10C	SB	-
11C	R	-
12C	O	-

Connector No.	M4
Connector Name	DATA LINK CONNECTOR
Connector Type	BD16FW

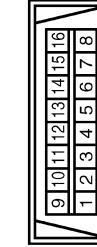

Terminal No.	Color of Wire	Signal Name [Specification]
3	LG	-
4	B	-
5	B	-
6	L	-
7	O	-
8	G	-
11	SB	-
14	P	-
16	Y	-

Connector No.	M11
Connector Name	WIRE TO WIRE
Connector Type	TH10FW-CS10-M3

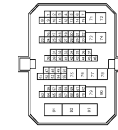

Terminal No.	Color of Wire	Signal Name [Specification]
3	P	-
5	O	-
6	G	-
8	R	-
11	P	-
12	L	-
13	V	-
14	Y	-
15	R	-
20	Y	-
21	BR	-
22	G	-
24	Y	-
25	L	-
28	BR	-
29	L	-
30	R	-
47	P	-
48	L	-
49	W	-
50	GR	-
51	LG	-
52	Y	-
53	V	-
54	SB	-
55	P	-
56	SB	-
60	V	-
61	GR	-
62	O	-
63	V	-
64	SHIELD	-
66	W	-
67	R	-
68	W	-
69	P	-
70	G	-
71	G	-

72	BR	-
73	L	-
74	W	-
75	BR	-
76	R	-
77	G	-
78	Y	-
79	G	-
80	R	-
81	W	-
82	W	-
83	O	-

A  
B  
C  
D  
E  
F  
G  
H  
I  
J  
K  
L  
M  
MWI  
O  
P

# COMBINATION METER

< ECU DIAGNOSIS INFORMATION >

## METER

Connector No.	M34
Connector Name	COMBINATION METER
Connector Type	TH407V-NH



1	2	3	4	5	6	7	8	9	10	11	12	13	14	15	16	17	18	19	20
21	22	23	24	25	26	27	28	29	30	31	32	33	34	35	36	37	38	39	40

Terminal No.	Color of Wire	Signal Name [Specification]
1	Y	BAT
2	O	IGN
3	B	GROUND
4	B	GROUND
5	SB	ILLUMINATION CONTROL
6	SB	TRIP RESET SWITCH
7	W	SW ILL POWER
8	O	METER CONTROL SW GND
9	L	ENTER SWITCH
10	R	SELECT SWITCH
11	Y	ILLUMINATION CONTROL SWITCH (1) (See accessories drive position)
12	R	ILLUMINATION CONTROL SWITCH (2) (See accessories drive position)
13	Y	ILLUMINATION CONTROL SWITCH (3) (See accessories drive position)
14	GR	ILLUMINATION CONTROL SWITCH (-)
15	BR	AIR BAG
16	L	AMBIENT SENSOR
17	P	AMBIENT SENSOR POWER
18	L	AMBIENT SENSOR GROUND
19	P	AMBIENT SENSOR GROUND
20	Y	CAN-H
21	L	CAN-L
22	P	CAN-L
23	B	GROUND
24	W	FUEL LEVEL SENSOR GROUND
25	BR	CHG
26	G	PARKING BRAKE SWITCH
27	V	BRAKE FLUID LEVEL SWITCH
28	R	WASHER LEVEL SWITCH
29	P	VEHICLE SPEED (2-PULSE)
30	P	VEHICLE SPEED (8-PULSE)
31	V	OD OFF / SPORTS
32	LG	FUEL LEVEL SENSOR
33	G	FUEL LEVEL SENSOR
34	G	SEAT BELT BUCKLE SWITCH (DRIVER SIDE)
35	SB	SEAT BELT BUCKLE SWITCH (PASSENGER SIDE)
36	R	SEAT BELT BUCKLE SWITCH (PASSENGER SIDE)

Connector No.	M50
Connector Name	A/C AUTO AMP
Connector Type	SAB40FH



1	2	3	4	5	6	7	8	9	10	11	12	13	14	15	16	17	18	19	20
21	22	23	24	25	26	27	28	29	30	31	32	33	34	35	36	37	38	39	40

Terminal No.	Color of Wire	Signal Name [Specification]
1	L	CAN-H
2	P	CAN-L
6	L	TX (AMP) SW & DISP
7	P	RX (SW/AMP)
10	L	LAN SIG
11	R	VACTR
15	O	SUN SENS
16	G	INTAKE SENS
17	R	ACC
19	B	IGN
20	G	IGN
26	GR	RR DEF F/B
27	BR	RR DEF ON
32	L	FAN PWM
34	P	AMB POWER
35	L	AMB SENS
36	LG	INCAR SENS
37	Y	SENS GND
39	B	GND (POWER)
40	Y	BAT

Connector No.	M57
Connector Name	CVT SHIFT SELECTOR
Connector Type	TK10FW



1	2	3	4	5	6	7	8	9
---	---	---	---	---	---	---	---	---

Terminal No.	Color of Wire	Signal Name [Specification]
1	LG	AWD SOL+
2	L	AWD SOL-
7	R	IGN
8	L	CAN-H
9	G	SOL BATT
10	B	GND

6	P	-
7	B	-
8	V	-
9	V	-



Connector No.	M68
Connector Name	WIRE TO WIRE
Connector Type	TK12FG-Y



5	4	3	2	1		
12	11	10	9	8	7	6

Terminal No.	Color of Wire	Signal Name [Specification]
1	R	-
2	R	-
3	Y	-
4	L	-
5	Y	-
6	G	-
7	SHIELD	-
8	V	-
9	Y	-
11	Y	-

Connector No.	M69
Connector Name	AWD CONTROL UNIT
Connector Type	TH16FW-NH



1	2	3	4	5	6	7	8
9	10	11	12	13	14	15	16

Terminal No.	Color of Wire	Signal Name [Specification]
1	LG	AWD SOL+
2	L	AWD SOL-
7	R	IGN
8	L	CAN-H
9	G	SOL BATT
10	B	GND

11	B	GND
14	Y	LOCK SW
16	P	CAN-E



Connector No.	M73
Connector Name	AIR BAG DIAGNOSIS SENSOR UNIT
Connector Type	TK28FY-EX-SC



20	21	17	24	19	1					
22	11	46	48	47	45	13	3	4	16	5
16	12	19	15	14	15	23	50	18	52	2

Terminal No.	Color of Wire	Signal Name [Specification]
1	B	IGN
2	B	GND
3	Y	INFLATOR DR 1+
4	Y	INFLATOR DR 1+ & DR 2+
5	Y	INFLATOR AS 1+
6	Y	INFLATOR AS 1-
11	SB	EC2S+
12	V	EC2S-
15	BR	A/B W/L
16	SHIELD	GND
18	V	A/B CUTOFF TELLTALE
21	L	CAN-H
24	R	SEATBELT W/L
45	Y	INFLATOR DR 2+
46	P	CAN-L
47	Y	INFLATOR AS 2+
48	Y	INFLATOR AS 2-
49	V	ODS INPUT

# COMBINATION METER

< ECU DIAGNOSIS INFORMATION >

## METER

Connector No.	M77
Connector Name	WIRE TO WIRE
Connector Type	TH80FW-CS1.9

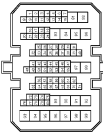

Terminal No.	Color of Wire	Signal Name [Specification]
1	SHIELD	-
2	B	-
3	W	-
4	R	-
5	Y	-
6	W	-
7	G	-
8	SHIELD	-
9	W	-
10	R	-
11	G	-
12	B	-
13	O	-
14	R	-
15	SB	-
16	R	-
17	V	-
18	P	-
19	B	-
20	LG	-
21	Y	-
22	O	-
23	LG	-
24	SB	-
25	Y	-
27	Y	-
28	R	-
30	Y	-
31	W	-
32	BR	-
34	Y	-
35	SHIELD	-
36	G	-
37	Y	-
40	O	-
41	LG	-
42	SB	-
46	LG	-

47	SR	-
48	SHIELD	-
49	R	-
50	LG	-
51	V	-
52	BR	-
53	BR	-
54	B	-
55	G	-
56	P	-
57	L	-
58	SB	-
59	SHIELD	-
60	B	-
61	R	-
62	W	-
63	O	-
64	Y	-
65	Y	-
66	V	-
67	GR	-
68	G	-
69	SHIELD	-
70	L	-
71	R	-
72	LG	-
73	Y	-
74	R	-
76	L	-
77	BR	-
79	B	-
80	W	-
81	LG	-
82	L	-
83	W	- [With automatic drive positioner]
84	R	- [Without automatic drive positioner]
85	V	-
86	W	-
87	R	-
88	G	-
89	B	-
90	O	-
91	G	-
92	BR	-
93	P	-
94	V	-
95	O	-
96	SB	-
97	L	-
98	LG	-

99	Y	-
----	---	---



Connector No.	M79
Connector Name	AIR BAG DIAGNOSIS SENSOR UNIT
Connector Type	TK12FY-IV-EX

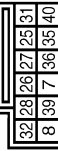

Terminal No.	Color of Wire	Signal Name [Specification]
7	Y	ELR RH+
8	Y	ELR RH+
25	L	BUCKLE SW RH
27	W	INF CURTAIN RH+
28	O	INF CURTAIN RH+
31	Y	SIDE INF RH+
32	Y	SIDE INF RH+
35	R	SIDE SENS RH+
36	G	SIDE SENS RH+
40	SHIELD	GND

Connector No.	M83
Connector Name	METER CONTROL SWITCH
Connector Type	TH12FW-NH

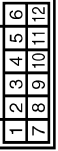

Terminal No.	Color of Wire	Signal Name [Specification]
1	R	-
2	O	-
3	W	-
4	GR	-
5	O	-
6	V	- [With automatic drive positioner]
6	Y	- [Without automatic drive positioner]
11	SB	-
12	L	-

Connector No.	M122
Connector Name	BCM (BODY CONTROL MODULE)
Connector Type	TH40FB-NH



Terminal No.	Color of Wire	Signal Name [Specification]
72	B	ROOM ANT Z-
73	W	ROOM ANT Z+
74	Y	PASSENGER DOOR ANT-
75	LG	PASSENGER DOOR ANT+
76	V	DRIVER DOOR ANT-
77	P	DRIVER DOOR ANT+
80	SB	IMMOBI ANTENNA CONTROL
81	O	IMMOBI ANTENNA SIGNAL
82	BR	IGN RELAY (F/B) CONT
83	P	KEYLESS ENTRY RECEIVER SIGNAL
87	R	COMBI SW INPUT 5
88	GR	COMBI SW INPUT 3
90	P	GAN-L
91	L	GAN-H
92	R	KEY SLOT ILL ON IND
93	P	ACC RELAY CONT
95	L	ACC RELAY CONT
96	Y	CVT SHIFT SELECTOR POWER SUPPLY
99	V	SHIFT P
100	P	PASSENGER DOOR REQUEST SW
101	W	DRIVER DOOR REQUEST SW
102	Y	BLOWER FAN MOTOR RELAY CONT
103	L	KEYLESS ENTRY RECEIVER POWER SUPPLY
107	O	COMBI SW INPUT 1
108	P	COMBI SW INPUT 4
109	SB	COMBI SW INPUT 2
110	G	HAZARD SW

JCNWM5350GB

A  
B  
C  
D  
E  
F  
G  
H  
I  
J  
K  
L  
M  
N  
O  
P

MWI

# COMBINATION METER

< ECU DIAGNOSIS INFORMATION >

## METER

Connector No.	M172
Connector Name	AV CONTROL UNIT
Connector Type	TH24PW-NH



36	37	38	39	40	41	42	43	44	45	46	47	48	49	50	51	52	53	54	55	56	57	58	59
----	----	----	----	----	----	----	----	----	----	----	----	----	----	----	----	----	----	----	----	----	----	----	----

Terminal No.	Color of Wire	Signal Name [Specification]
36	O	SIGNAL VCC
37	SB	SIGNAL GND
38	G	HP
39	L	COMM (DISP->CONT)
40	W	RGB AREA (VS) SIGNAL
41	SHIELD	SHIELD
42	B	RGB SYNC
43	G	RGB (RED) SIGNAL
44	L	RGB (GREEN) SIGNAL
45	Y	RGB (BLUE) SIGNAL
46	V	COMPOSITE IMAGE SIGNAL GND
47	LG	COMPOSITE IMAGE SIGNAL
48	Y	INVERTER VCC
49	BR	INVERTER GND
50	R	VP
51	P	COMM (CONT->DISP)
52	SHIELD	SHIELD
57	SHIELD	SHIELD
58	SHIELD	SHIELD

Connector No.	M174
Connector Name	AV CONTROL UNIT
Connector Type	TH24PW-NH



76	77	78	79	80	81	82	83	84	85	86	87	88	89	90	91	92
----	----	----	----	----	----	----	----	----	----	----	----	----	----	----	----	----

Terminal No.	Color of Wire	Signal Name [Specification]
76	LG	AV COMM (L)
77	SB	AV COMM (H)
78	LG	AV COMM (L)

Terminal No.	Color of Wire	Signal Name [Specification]
79	SB	AV COMM (H)
80	P	CAN-L
81	L	CAN-H
82	V	SW GND
86	SHIELD	SHIELD
87	R	TEL VOICE SIGNAL (+)
88	L	TEL VOICE SIGNAL (-)
92	V	VEHICLE SPEED SIGNAL (8-PULSE)
93	LG	PARKING BRAKE (With BOSE system)
93	G	PARKING BRAKE (Without BOSE system)
94	SB	REVERSE
95	G	IGNITION
96	W	DISK EJECT SIGNAL
102	W	AUX SOUND SIGNAL GND
103	B	AUX SOUND SIGNAL LH (+)
104	R	AUX SOUND SIGNAL RH (+)

Connector No.	M180
Connector Name	AV CONTROL UNIT
Connector Type	TH24PW-NH



51	52	53	54	55	56	57	58	59	60	61	62	63	64	65	66	67	68	69	70	71	72	73	74	75	76
----	----	----	----	----	----	----	----	----	----	----	----	----	----	----	----	----	----	----	----	----	----	----	----	----	----

Terminal No.	Color of Wire	Signal Name [Specification]
65	LG	PARKING BRAKE
67	BR	COMPOSITE IMAGE SIGNAL GND
68	GR	COMPOSITE IMAGE SIGNAL
71	SHIELD	SHIELD
72	B	MICROPHONE VCC
73	R	COMM (CONT->DISP)
74	P	CAN-L
75	LG	AV COMM (L)
76	LG	AV COMM (L)
79	R	ILLUMINATION SIGNAL
80	G	IGNITION
81	SB	REVERSE
82	V	VEHICLE SPEED SIGNAL (8-PULSE)
83	SHIELD	SHIELD
87	W	MICROPHONE SIGNAL
88	SHIELD	SHIELD
89	G	COMM (DISP->CONT)
90	L	CAN-H
91	SB	AV COMM (H)
92	SB	AV COMM (H)

JCNWM5351 GB

## Fail-Safe

### FAIL-SAFE

The combination meter activates the fail-safe control if CAN communication with each unit is malfunctioning.

INFOID:000000006262186

# COMBINATION METER

## < ECU DIAGNOSIS INFORMATION >

Function		Specifications	
Speedometer		Reset to zero by suspending communication.	A
Tachometer			B
Engine coolant temperature gauge			C
Illumination control		When suspending communication, changes to nighttime mode.	
Information display	Door open warning	The display turns off by suspending communication.	C
	Parking brake release warning		D
	Low tire pressure warning		E
	Fuel filler cap warning		F
	Instantaneous fuel warning	<ul style="list-style-type: none"> <li>When reception time of an abnormal signal is 2 seconds or less, the last received datum is used for calculation to indicate the result.</li> <li>When reception time of an abnormal signal is more than two seconds, the last result calculated during normal condition is indicated.</li> </ul>	
	Average fuel consumption		
	Average vehicle speed		
Travel distance			
Buzzer		The buzzer turns off by suspending communication.	
Warning lamp/indicator lamp	ABS warning lamp	The lamp turns on by suspending communication.	G
	SLIP indicator lamp		H
	Brake warning lamp		I
	AWD warning lamp		J
	Malfunction indicator lamp		K
	Low tire pressure warning lamp	The lamp turns ON after flashing for 1 minute.	L
	High beam indicator lamp	The lamp turns off by suspending communication.	
	Turn signal indicator lamp		
	Light indicator lamp		
	Oil pressure warning lamp		
	CRUISE indicator lamp		
	O/D OFF indicator lamp		
	VDC OFF indicator lamp		
AWD LOCK indicator lamp			
Key warning lamp			

## DTC Index

INFOID:000000006262187

Display contents of CONSULT-III	Diagnostic item is detected when ...	Refer to	
CAN COMM CIRCUIT [U1000]	When combination meter is not transmitting or receiving CAN communication signal for 2 seconds or more.	<a href="#">MWI-39</a> , "Diagnosis Procedure"	MWI
CONTROL UNIT (CAN) [U1010]	When detecting error during the initial diagnosis of the CAN controller of combination meter.	<a href="#">MWI-40</a> , "Diagnosis Procedure"	O
VEHICLE SPEED [B2205]	The abnormal vehicle speed signal is input from the ABS actuator and electric unit (control unit) for 2 seconds or more.	<a href="#">MWI-41</a> , "Diagnosis Procedure"	P

## COMBINATION METER

### < ECU DIAGNOSIS INFORMATION >

Display contents of CONSULT-III	Diagnostic item is detected when ...	Refer to
ENGINE SPEED [B2267]	If ECM continuously transmits abnormal engine speed signals for 2 seconds or more.	<a href="#">MWI-42.</a> <a href="#">"Diagnosis Procedure"</a>
WATER TEMP [B2268]	If ECM continuously transmits abnormal engine coolant temperature signals for 60 seconds or more.	<a href="#">MWI-43.</a> <a href="#">"Diagnosis Procedure"</a>

# IPDM E/R (INTELLIGENT POWER DISTRIBUTION MODULE ENGINE ROOM)

< ECU DIAGNOSIS INFORMATION >

## IPDM E/R (INTELLIGENT POWER DISTRIBUTION MODULE ENGINE ROOM)

Reference Value

INFOID:000000006845202

VALUES ON THE DIAGNOSIS TOOL

Monitor Item	Condition		Value/Status
MOTOR FAN REQ	Engine idle speed	Changes depending on engine coolant temperature, air conditioner operation status, vehicle speed, etc.	1/2/3/4
AC COMP REQ	Engine running	A/C switch OFF	Off
		A/C switch ON (Compressor is operating)	On
TAIL&CLR REQ	Lighting switch OFF		Off
	Lighting switch 1ST, 2ND, HI or AUTO (Light is illuminated)		On
HL LO REQ	Lighting switch OFF		Off
	Lighting switch 2ND HI or AUTO (Light is illuminated)		On
HL HI REQ	Lighting switch OFF		Off
	Lighting switch HI		On
FR FOG REQ	Lighting switch 2ND or AUTO (Light is illuminated)	Front fog lamp switch OFF	Off
		<ul style="list-style-type: none"> <li>• Front fog lamp switch ON</li> <li>• Daytime running light activated (Only for Canada)</li> </ul>	On
FR WIP REQ	Ignition switch ON	Front wiper switch OFF	Stop
		Front wiper switch INT	1LOW
		Front wiper switch LO	Low
		Front wiper switch HI	Hi
WIP AUTO STOP	Ignition switch ON	Front wiper stop position	STOP P
		Any position other than front wiper stop position	ACT P
WIP PROT	Ignition switch ON	Front wiper operates normally	Off
		Front wiper stops at fail-safe operation	BLOCK
IGN RLY1 -REQ	Ignition switch OFF or ACC		Off
	Ignition switch ON		On
IGN RLY	Ignition switch OFF or ACC		Off
	Ignition switch ON		On
PUSH SW	Release the push-button ignition switch		Off
	Press the push-button ignition switch		On
INTER/NP SW	Ignition switch ON	Selector lever in any position other than P or N	Off
		Selector lever in P or N position	On
ST RLY CONT	Ignition switch ON		Off
	At engine cranking		On
IHBT RLY -REQ	Ignition switch ON		Off
	At engine cranking		On

A  
B  
C  
D  
E  
F  
G  
H  
I  
J  
K  
L  
M

MWI

O  
P

# IPDM E/R (INTELLIGENT POWER DISTRIBUTION MODULE ENGINE ROOM)

## < ECU DIAGNOSIS INFORMATION >

Monitor Item	Condition	Value/Status	
ST/INHI RLY	Ignition switch ON	Off	
	At engine cranking	INHI ON → ST ON	
	The status of starter relay or starter control relay cannot be recognized by the battery voltage malfunction, etc. when the starter relay is ON and the starter control relay is OFF	UNKWN	
DETENT SW	Ignition switch ON	<ul style="list-style-type: none"> <li>• Press the selector button with selector lever in P position</li> <li>• Selector lever in any position other than P</li> </ul>	Off
	Release the selector button with selector lever in P position		On
S/L RLY -REQ	<b>NOTE:</b> The item is indicated, but not monitored.	Off	
S/L STATE	<b>NOTE:</b> The item is indicated, but not monitored.	UNLOCK	
DTRL REQ	<b>NOTE:</b> The item is indicated, but not monitored.	Off	
OIL P SW	Ignition switch OFF, ACC or engine running	Open	
	Ignition switch ON	Close	
HOOD SW	<b>NOTE:</b> The item is indicated, but not monitored.	Off	
HL WASHER REQ	<b>NOTE:</b> The item is indicated, but not monitored.	Off	
THFT HRN REQ	Not operating	Off	
	<ul style="list-style-type: none"> <li>• Panic alarm is activated</li> <li>• Horn is activated with VEHICLE SECURITY (THEFT WARNING) SYSTEM</li> </ul>	On	
HORN CHIRP	Not operating	Off	
	Door locking with Intelligent Key (horn chirp mode)	On	
CRNRNG LMP REQ	<b>NOTE:</b> The item is indicated, but not monitored.	Off	



# IPDM E/R (INTELLIGENT POWER DISTRIBUTION MODULE ENGINE ROOM)

< ECU DIAGNOSIS INFORMATION >

## TERMINAL LAYOUT

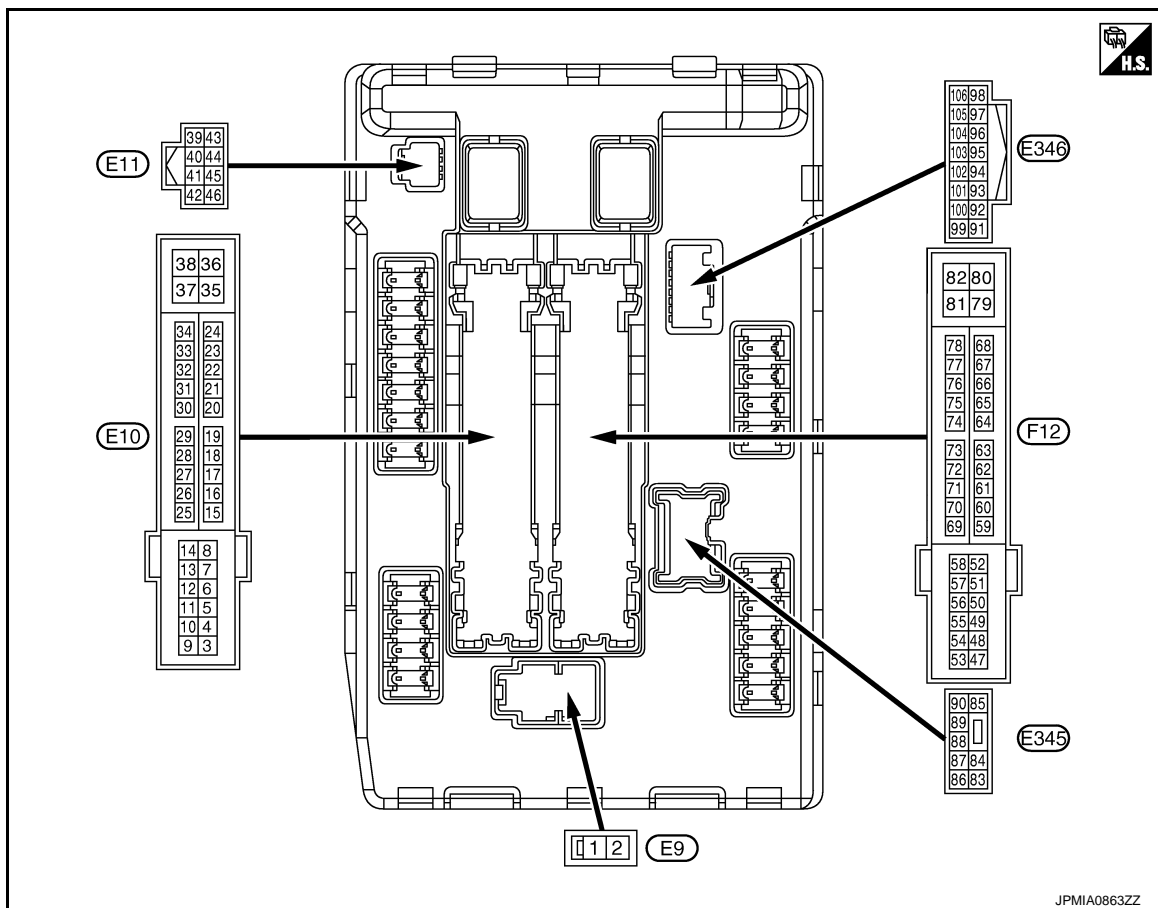

## PHYSICAL VALUES

Terminal No. (Wire color)		Description		Condition		Value (Approx.)
+	-	Signal name	Input/ Output			
1 (R)	Ground	Battery power supply	Input	Ignition switch OFF		Battery voltage
2 (L)	Ground	Battery power supply	Input	Ignition switch OFF		Battery voltage
4 (LG)	Ground	Front wiper LO	Output	Ignition switch OFF	Front wiper switch OFF	0 V
				Ignition switch ON	Front wiper switch LO	Battery voltage
5 (Y)	Ground	Front wiper HI	Output	Ignition switch OFF	Front wiper switch OFF	0 V
				Ignition switch ON	Front wiper switch HI	Battery voltage
7 (GR)	Ground	Tail, license plate lamps & illuminations	Output	Ignition switch ON	Lighting switch OFF	0 V
					Lighting switch 1ST	Battery voltage
10 (BR)	Ground	ECM relay power supply	Output	Ignition switch OFF (More than a few seconds after turning ignition switch OFF)		0 V
				<ul style="list-style-type: none"> <li>Ignition switch ON</li> <li>Ignition switch OFF (For a few seconds after turning ignition switch OFF)</li> </ul>		Battery voltage
12 (B)	Ground	Ground	—	Ignition switch ON		0 V

A  
B  
C  
D  
E  
F  
G  
H  
I  
J  
K  
L  
M  
N  
O  
P

MWI

# IPDM E/R (INTELLIGENT POWER DISTRIBUTION MODULE ENGINE ROOM)

## < ECU DIAGNOSIS INFORMATION >

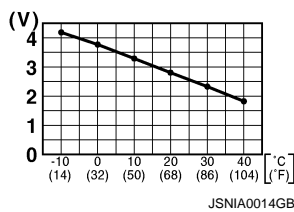
Terminal No. (Wire color)		Description		Condition		Value (Approx.)
+	-	Signal name	Input/ Output			
13 (SB)	Ground	Fuel pump power supply	Output	Approximately 1 second or more after turning the ignition switch ON		0 V
				<ul style="list-style-type: none"> <li>Approximately 1 second after turning the ignition switch ON</li> <li>Engine running</li> </ul>		Battery voltage
15 (W)	Ground	Ignition relay power supply	Output	Ignition switch OFF		0 V
				Ignition switch ON		Battery voltage
16 (R)	Ground	Front wiper auto stop	Input	Ignition switch ON	Front wiper stop position	0 V
					Any position other than front wiper stop position	Battery voltage
19 (Y)	Ground	Ignition relay power supply	Output	Ignition switch OFF		0 V
				Ignition switch ON		Battery voltage
20 (L)	Ground	Ambient sensor ground	Output	Ignition switch ON		0 V
21 (O)	Ground	Ambient sensor	Input	Ignition switch ON <b>NOTE:</b> Changes depending to ambient temperature		 <p style="text-align: right; font-size: small;">JSNIA0014GB</p>
22 (SB)	Ground	Refrigerant pressure sensor ground	Output	Engine running	<ul style="list-style-type: none"> <li>Warm-up condition</li> <li>Idle speed</li> </ul>	0 V
23 (GR)	Ground	Refrigerant pressure sensor	Output	Engine running	<ul style="list-style-type: none"> <li>Warm-up condition</li> <li>Both A/C switch and blower fan motor switch ON (Compressor operates)</li> </ul>	1.0 - 4.0 V
24 (G)	Ground	Refrigerant pressure sensor power supply	Input	Ignition switch OFF		0 V
				Ignition switch ON		5.0 V
25 (GR)	Ground	Ignition relay power supply	Output	Ignition switch OFF		0 V
				Ignition switch ON		Battery voltage
26*1 (Y)	Ground	Ignition relay power supply	Output	Ignition switch OFF		0 V
				Ignition switch ON		Battery voltage
27 (W)	Ground	Ignition relay monitor	Input	Ignition switch OFF or ACC		Battery voltage
				Ignition switch ON		0 V
28 (SB)	Ground	Push-button ignition switch	Input	Press the push-button ignition switch		0 V
				Release the push-button ignition switch		Battery voltage
30 (BR)	Ground	Starter relay control	Input	Ignition switch ON	Selector lever in any position other than P or N	0 V
					Selector lever P or N	Battery voltage
34 (O)	Ground	Cooling fan relay-3 control	Input	Cooling fan stopped		Battery voltage
				Cooling fan at HI operation		0 V
35 (P)	Ground	Cooling fan relay-1 power supply	Input	Cooling fan stopped		Battery voltage
				Cooling fan at LO operation		6.0 V
36 (G)	Ground	Battery power supply	Input	Ignition switch OFF		Battery voltage

# IPDM E/R (INTELLIGENT POWER DISTRIBUTION MODULE ENGINE ROOM)

## < ECU DIAGNOSIS INFORMATION >

Terminal No. (Wire color)		Description		Condition	Value (Approx.)		
+	-	Signal name	Input/ Output				
38 (GR)	Ground	Cooling fan relay-1 power supply	Output	Cooling fan not operating	0 V	A	
				Cooling fan at LO operation	6.0 V	B	
39 (P)	—	CAN-L	Input/ Output	—	—	C	
40 (L)	—	CAN-H	Input/ Output	—	—		
41 (B)	Ground	Ground	—	Ignition switch ON	0 V	D	
42 (SB)	Ground	Cooling fan relay-2 control	Input	Cooling fan stopped	Battery voltage		
				<ul style="list-style-type: none"> <li>Cooling fan MID operating</li> <li>Cooling fan HI operating</li> </ul>	0 V	E	
43 (Y)	Ground	CVT shift selector (Detention switch)	Input	Ignition switch ON	Press the selector button (selector lever P)	Battery voltage	F
					<ul style="list-style-type: none"> <li>Selector lever in any position other than P</li> <li>Release the selector button (selector lever P)</li> </ul>	0 V	G
44 (W)	Ground	Horn relay control	Input	The horn is deactivated	Battery voltage	H	
				The horn is activated	0 V		
45 (O)	Ground	Horn switch	Input	The horn is deactivated	Battery voltage	I	
				The horn is activated	0 V		
46 (BR)	Ground	Starter relay control	Input	Ignition switch ON	Selector lever in any position other than P or N	0 V	J
					Selector lever P or N	Battery voltage	
48 (W)	Ground	A/C relay power supply	Output	Engine running	A/C switch OFF	0 V	K
					A/C switch ON (A/C compressor is operating)	Battery voltage	
49 (R/B)	Ground	ECM relay power supply	Output	Ignition switch OFF (More than a few seconds after turning ignition switch OFF)	0 V	L	
					<ul style="list-style-type: none"> <li>Ignition switch ON</li> <li>Ignition switch OFF (For a few seconds after turning ignition switch OFF)</li> </ul>	Battery voltage	M
51 (LG)	Ground	Ignition relay power supply	Output	Ignition switch OFF	0 V		
					Ignition switch ON	Battery voltage	MWI
52 (Y/G)	Ground	Ignition relay power supply	Output	Ignition switch OFF	0 V		
					Ignition switch ON	Battery voltage	
53 (R/W)	Ground	ECM relay power supply	Output	Ignition switch OFF (More than a few seconds after turning ignition switch OFF)	0 V	O	
					<ul style="list-style-type: none"> <li>Ignition switch ON</li> <li>Ignition switch OFF (For a few seconds after turning ignition switch OFF)</li> </ul>	Battery voltage	P

# IPDM E/R (INTELLIGENT POWER DISTRIBUTION MODULE ENGINE ROOM)

## < ECU DIAGNOSIS INFORMATION >

Terminal No. (Wire color)		Description		Condition	Value (Approx.)
+	-	Signal name	Input/ Output		
54 (G/W)	Ground	Throttle control motor re- lay power supply	Output	Ignition switch OFF (More than a few seconds after turning ignition switch OFF)	0 V
				<ul style="list-style-type: none"> <li>Ignition switch ON</li> <li>Ignition switch OFF (For a few seconds after turning igni- tion switch OFF)</li> </ul>	Battery voltage
55 (W/L)	Ground	ECM power supply	Output	Ignition switch OFF	Battery voltage
56 (R/Y)	Ground	Ignition relay power supply	Output	Ignition switch OFF	0 V
				Ignition switch ON	Battery voltage
57 (O)	Ground	Ignition relay power supply	Output	Ignition switch OFF	0 V
				Ignition switch ON	Battery voltage
58 (Y)	Ground	Ignition relay power supply	Output	Ignition switch OFF	0 V
				Ignition switch ON	Battery voltage
69 (W/B)	Ground	ECM relay control	Output	Ignition switch OFF (More than a few seconds after turning ignition switch OFF)	Battery voltage
				<ul style="list-style-type: none"> <li>Ignition switch ON</li> <li>Ignition switch OFF (For a few seconds after turning igni- tion switch OFF)</li> </ul>	0 - 1.5 V
70 (O)	Ground	Throttle control motor re- lay control	Output	Ignition switch ON → OFF	0 - 1.0 V ↓ Battery voltage ↓ 0 V
				Ignition switch ON	0 - 1.0 V
72 (R/B)	Ground	Starter relay control	Input	Ignition switch ON	Selector lever in any posi- tion other than P or N 0 V
				Selector lever P or N	Battery voltage
75 (LG)	Ground	Oil pressure switch	Input	Ignition switch ON	Engine stopped 0 V
				Engine running	Battery voltage

# IPDM E/R (INTELLIGENT POWER DISTRIBUTION MODULE ENGINE ROOM)

## < ECU DIAGNOSIS INFORMATION >

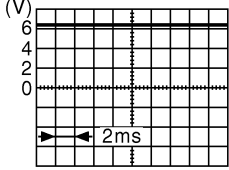
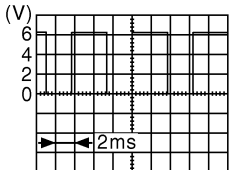
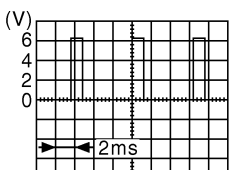
Terminal No. (Wire color)		Description		Condition		Value (Approx.)
+	-	Signal name	Input/ Output			
76 (SB)	Ground	Power generation command signal	Output	Ignition switch ON		 <p>6.3 V</p>
				40% is set on "ACTIVE TEST", "ALTERNATOR DUTY" of "ENGINE"		 <p>3.8 V</p>
				80% is set on "ACTIVE TEST", "ALTERNATOR DUTY" of "ENGINE"		 <p>1.4 V</p>
77 (GR)	Ground	Fuel pump relay control	Output	<ul style="list-style-type: none"> <li>Approximately 1 second after turning the ignition switch ON</li> <li>Engine running</li> </ul>		0 - 1.5 V
				Approximately 1 second or more after turning the ignition switch ON		Battery voltage
80 (B)	Ground	Starter motor	Output	At engine cranking		Battery voltage
83 (Y)	Ground	Headlamp LO (RH)	Output	Ignition switch ON	Lighting switch OFF	0 V
					Lighting switch 2ND	Battery voltage
84 (L)	Ground	Headlamp LO (LH)	Output	Ignition switch ON	Lighting switch OFF	0 V
					Lighting switch 2ND	Battery voltage
86 (SB)	Ground	Front fog lamp (RH)	Output	Lighting switch 2ND	Front fog lamp switch OFF	0 V
					<ul style="list-style-type: none"> <li>Front fog lamp switch ON</li> <li>Daytime running light activated (Only for Canada)</li> </ul>	Battery voltage
87 (GR)	Ground	Front fog lamp (LH)	Output	Lighting switch 2ND	Front fog lamp switch OFF	0 V
					<ul style="list-style-type: none"> <li>Front fog lamp switch ON</li> <li>Daytime running light activated (Only for Canada)</li> </ul>	Battery voltage
88 (W)	Ground	Washer pump power supply	Output	Ignition switch ON		Battery voltage

A  
B  
C  
D  
E  
F  
G  
H  
I  
J  
K  
L  
M

MWI

O  
P

# IPDM E/R (INTELLIGENT POWER DISTRIBUTION MODULE ENGINE ROOM)

## < ECU DIAGNOSIS INFORMATION >

Terminal No. (Wire color)		Description		Condition		Value (Approx.)
+	-	Signal name	Input/ Output			
89 (L)	Ground	Headlamp HI (RH)	Output	Ignition switch OFF		0 V
				Ignition switch ON	<ul style="list-style-type: none"> <li>Lighting switch HI</li> <li>Lighting switch PASS</li> </ul>	Battery voltage
90 (G)	Ground	Headlamp HI (LH)	Output	Ignition switch OFF		0 V
				Ignition switch ON	<ul style="list-style-type: none"> <li>Lighting switch HI</li> <li>Lighting switch PASS</li> </ul>	Battery voltage
91 (R)	Ground	Parking lamp (RH)	Output	Ignition switch OFF		0 V
				Ignition switch ON	Lighting switch 1ST	Battery voltage
92 (LG)	Ground	Parking lamp (LH)	Output	Ignition switch OFF		0 V
				Ignition switch ON	Lighting switch 1ST	Battery voltage
99 (BR)	Ground	Ambient sensor ground	Input	Ignition switch ON		0 V
100 (SB)	Ground	Ambient sensor	Output	Ignition switch ON		<p>(V)</p> <p>4 3 2 1 0</p> <p>-10 0 10 20 30 40 [°C]</p> <p>(14) (32) (50) (68) (86) (104) [°F]</p> <p>JSNIA0014GB</p>
				Ignition switch ON <b>NOTE:</b> Changes depending to ambient temperature		
101 (L)	Ground	Refrigerant pressure sensor ground	Input	Engine running	<ul style="list-style-type: none"> <li>Warm-up condition</li> <li>Idle speed</li> </ul>	0 V
102 (B)	Ground	Refrigerant pressure sensor	Input	Engine running	<ul style="list-style-type: none"> <li>Warm-up condition</li> <li>Both A/C switch and blower fan motor switch ON (Compressor operates)</li> </ul>	1.0 - 4.0 V
103 (P)	Ground	Refrigerant pressure sensor power supply	Output	Ignition switch OFF		0 V
				Ignition switch ON		5.0 V

\*1: AWD models only

# IPDM E/R (INTELLIGENT POWER DISTRIBUTION MODULE ENGINE ROOM)

< ECU DIAGNOSIS INFORMATION >

## Wiring Diagram - IPDM E/R -

INFOID:000000006845203

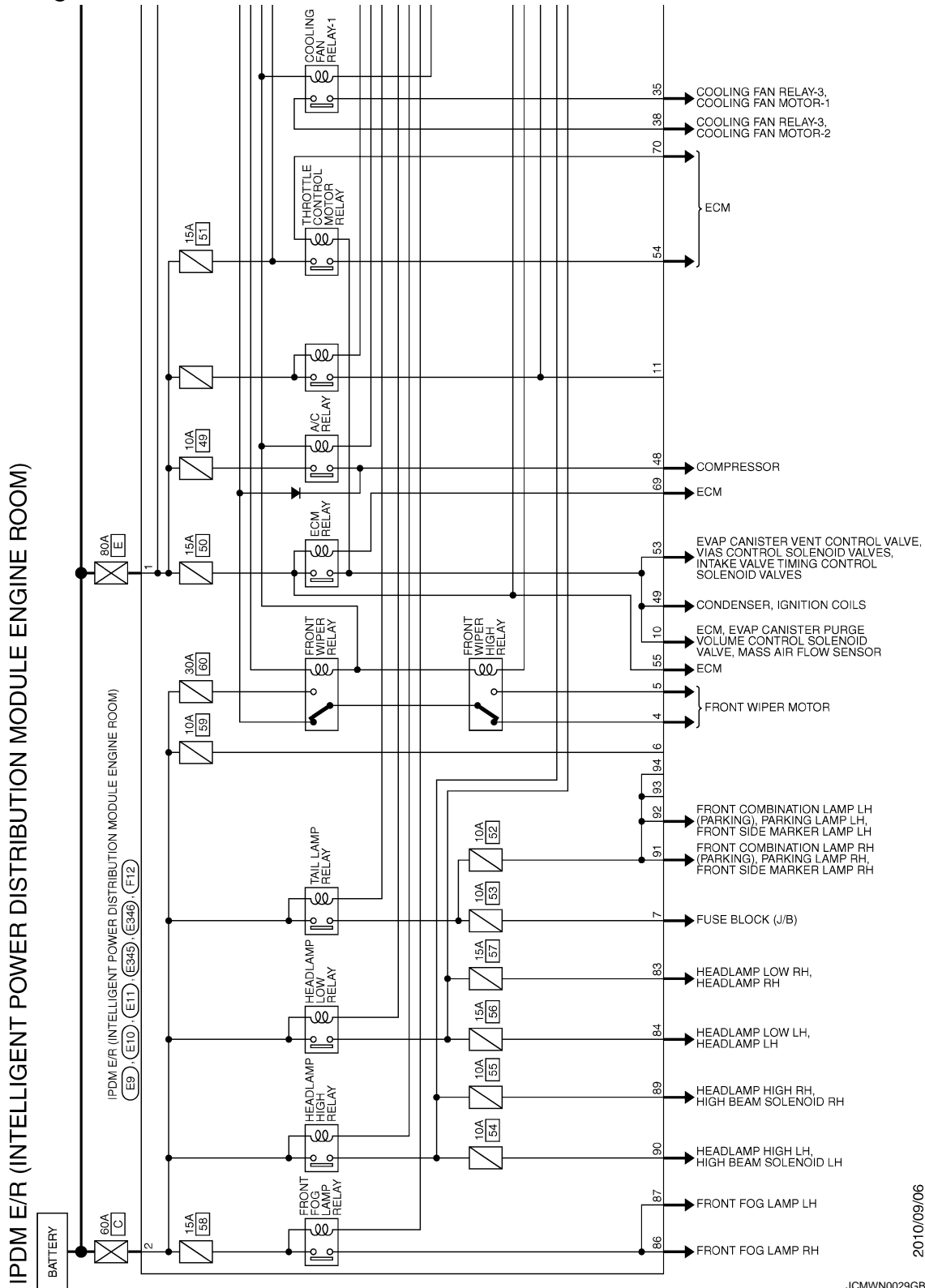

A  
B  
C  
D  
E  
F  
G  
H  
I  
J  
K  
L  
M  
N  
O  
P

MWI

2010/09/06

JCMWN0029GB

# IPDM E/R (INTELLIGENT POWER DISTRIBUTION MODULE ENGINE ROOM)

< ECU DIAGNOSIS INFORMATION >

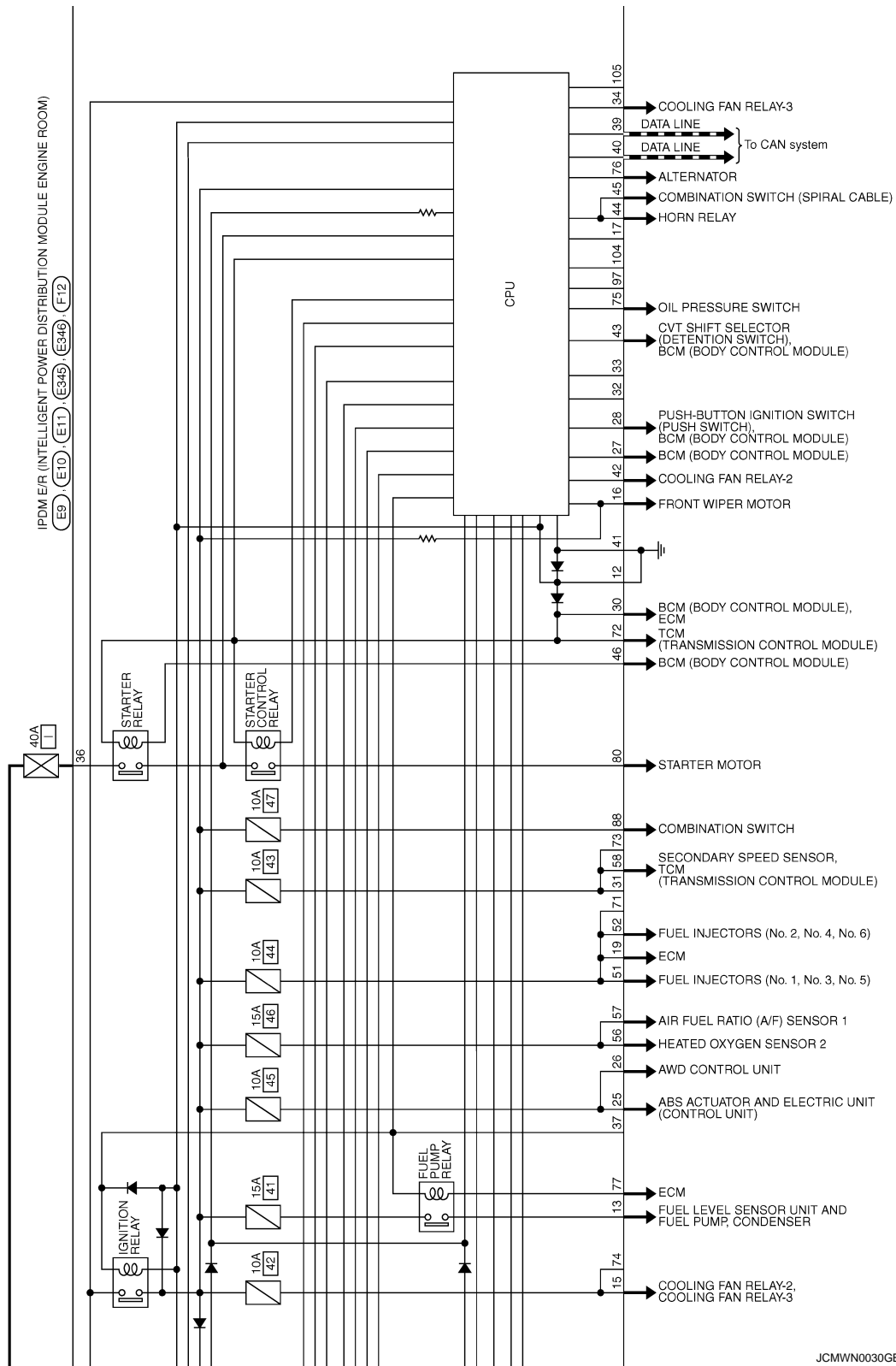

JCMWN0030GB



# IPDM E/R (INTELLIGENT POWER DISTRIBUTION MODULE ENGINE ROOM)

< ECU DIAGNOSIS INFORMATION >

A  
B  
C  
D  
E  
F  
G  
H  
I  
J  
K  
L  
M  
N  
O  
P

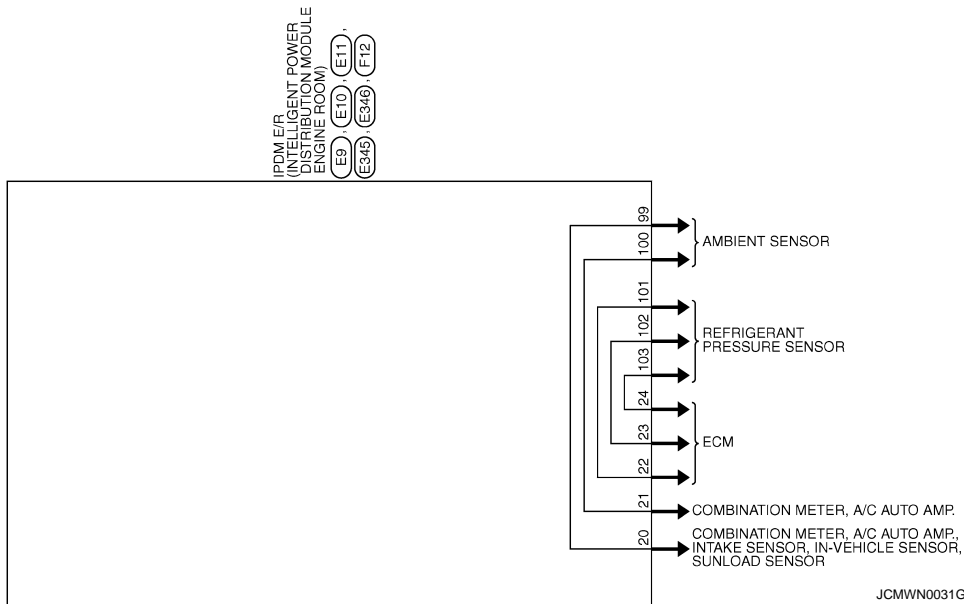

MWI

# IPDM E/R (INTELLIGENT POWER DISTRIBUTION MODULE ENGINE ROOM)

< ECU DIAGNOSIS INFORMATION >

77	GR	-
80	B	-

Connector No.	E346
Connector Name	IPDM E/R INTELLIGENT POWER DISTRIBUTION MODULE ENGINE ROOM
Connector Type	TH18FW-NH



98	97	96	95	94	93	92	91
106	103	104	103	102	101	100	99

Terminal No.	Color of Wire	Signal Name [Specification]
91	R	-
92	LG	-
99	BR	-
100	SB	-
101	L	-
102	B	-
103	P	-

Connector No.	F12
Connector Name	IPDM E/R INTELLIGENT POWER DISTRIBUTION MODULE ENGINE ROOM
Connector Type	TH20FW-CS12-M4



53	51	52	54	55	56	57	58	59	60
47	48	49	50	51	52	53	54	55	56

Terminal No.	Color of Wire	Signal Name [Specification]
48	W	-
49	R/B	-
51	LG	-
52	Y/G	-
53	R/W	-
54	G/W	-
55	W/L	-
56	R/Y	-
57	O	-
58	Y	-
60	W/B	-
70	O	-
72	R/B	-
75	LG	-
78	SB	-

## IPDM E/R (INTELLIGENT POWER DISTRIBUTION MODULE ENGINE ROOM)

35	P	-
36	G	-
38	GR	-

Connector No.	E11
Connector Name	IPDM E/R INTELLIGENT POWER DISTRIBUTION MODULE ENGINE ROOM
Connector Type	TH08FW-NH



42	41	40	39
46	45	44	43

Terminal No.	Color of Wire	Signal Name [Specification]
39	P	-
40	L	-
41	SB	-
42	B	-
43	Y	-
44	W	-
45	O	-
46	BR	-

Connector No.	E345
Connector Name	IPDM E/R INTELLIGENT POWER DISTRIBUTION MODULE ENGINE ROOM
Connector Type	NS08FW-CS



85	84	83
90	89	88
87	86	

Terminal No.	Color of Wire	Signal Name [Specification]
83	Y	-
84	L	-
86	SB	-
87	GR	-
88	W	-
89	L	-
90	G	-

Connector No.	E9
Connector Name	IPDM E/R INTELLIGENT POWER DISTRIBUTION MODULE ENGINE ROOM
Connector Type	LOPE-MC



1	2
---	---

Terminal No.	Color of Wire	Signal Name [Specification]
1	R	-
2	L	-

Connector No.	E10
Connector Name	IPDM E/R INTELLIGENT POWER DISTRIBUTION MODULE ENGINE ROOM
Connector Type	TH20FW-CS12-M4-1V



9	10	11	12	13	14	23	22	21	20
3	4	5	6	7	8	15	16	17	18
31	32	33	34	35	36	37	38	39	38

Terminal No.	Color of Wire	Signal Name [Specification]
4	LG	-
5	Y	-
7	GR	-
10	BR	-
12	B	-
13	SB	-
15	W	-
16	R	-
18	Y	-
20	L	-
21	O	-
22	SB	-
23	GR	-
24	G	-
25	GR	-
26	Y	-
27	W	-
28	SB	-
30	BR	-
34	O	-

JCMWN0032GB

INFOID:000000006845204

## Fail-safe

### CAN COMMUNICATION CONTROL

When CAN communication with ECM and BCM is impossible, IPDM E/R performs fail-safe control. After CAN communication recovers normally, it also returns to normal control.

If No CAN Communication Is Available With ECM

# IPDM E/R (INTELLIGENT POWER DISTRIBUTION MODULE ENGINE ROOM)

## < ECU DIAGNOSIS INFORMATION >

Control part	Fail-safe operation
Cooling fan	<ul style="list-style-type: none"> <li>• Turns ON the cooling fan relay-2 and the cooling fan relay-3 when ignition switch is turned ON (Cooling fan operates at HI)</li> <li>• Turns OFF the cooling fan relay-1, the cooling fan relay-2 and the cooling fan relay-3 when the ignition switch is turned OFF (Cooling fan does not operate)</li> </ul>
A/C compressor	A/C relay OFF
Alternator	Outputs the power generation command signal (PWM signal) 0%

### If No CAN Communication Is Available With BCM

Control part	Fail-safe operation
Headlamp	<ul style="list-style-type: none"> <li>• Turns ON the headlamp low relay when the ignition switch is turned ON</li> <li>• Turns OFF the headlamp low relay when the ignition switch is turned OFF</li> <li>• Headlamp high relay OFF</li> </ul>
<ul style="list-style-type: none"> <li>• Parking lamps</li> <li>• License plate lamps</li> <li>• Side maker lamps</li> <li>• Illuminations</li> <li>• Tail lamps</li> </ul>	<ul style="list-style-type: none"> <li>• Turns ON the tail lamp relay when the ignition switch is turned ON</li> <li>• Turns OFF the tail lamp relay when the ignition switch is turned OFF</li> </ul>
Front wiper	<ul style="list-style-type: none"> <li>• The status just before activation of fail-safe control is maintained until the ignition switch is turned OFF while the front wiper is operating at LO or HI speed.</li> <li>• The wiper is operated at LO speed until the ignition switch is turned OFF if the fail-safe control is activated while the front wiper is set in the INT/AUTO mode and the front wiper motor is operating.</li> </ul>
Front fog lamps	Front fog lamp relay OFF
Horn	Horn OFF
Ignition relay	The status just before activation of fail-safe is maintained.
Starter motor	Starter control relay OFF

### IGNITION RELAY MALFUNCTION DETECTION FUNCTION

- IPDM E/R monitors the voltage at the contact circuit and excitation coil circuit of the ignition relay inside it.
- IPDM E/R judges the ignition relay error if the voltage differs between the contact circuit and the excitation coil circuit.
- If the ignition relay cannot turn OFF due to contact seizure, it activates the tail lamp relay for 10 minutes to alert the user to the ignition relay malfunction when the ignition switch is turned OFF.

Voltage judgment		IPDM E/R judgment	Operation
Ignition relay contact side	Ignition relay excitation coil side		
ON	ON	Ignition relay ON normal	—
OFF	OFF	Ignition relay OFF normal	—
ON	OFF	Ignition relay ON stuck	<ul style="list-style-type: none"> <li>• Detects DTC "B2098: IGN RELAY ON"</li> <li>• Turns ON the tail lamp relay for 10 minutes</li> </ul>
OFF	ON	Ignition relay OFF stuck	Detects DTC "B2099: IGN RELAY OFF"

### FRONT WIPER CONTROL

IPDM E/R detects front wiper stop position by a front wiper auto stop signal.

When a front wiper stop position signal is in the conditions listed below, IPDM E/R stops power supply to wiper after repeating a front wiper 10 seconds activation and 20 seconds stop five times.

Ignition switch	Front wiper switch	Front wiper stop position signal
ON	OFF	The front wiper stop position signal (stop position) cannot be input for 10 seconds.
	ON	The front wiper auto stop signal does not change for 10 seconds.

# IPDM E/R (INTELLIGENT POWER DISTRIBUTION MODULE ENGINE ROOM)

## < ECU DIAGNOSIS INFORMATION >

### NOTE:

This operation status can be confirmed on the IPDM E/R “Data Monitor” that displays “BLOCK” for the item “WIP PROT” while the wiper is stopped.

### STARTER MOTOR PROTECTION FUNCTION

IPDM E/R turns OFF the starter control relay to protect the starter motor when the starter control relay remains active for 90 seconds.

### DTC Index

INFOID:000000006845205

### NOTE:

- The details of time display are as follows.
  - CRNT: A malfunction is detected now.
  - PAST: A malfunction was detected in the past.
- IGN counter is displayed on FFD (Freeze Frame data).
  - The number is 0 when is detected now.
  - The number increases like 1 → 2 ... 38 → 39 after returning to the normal condition whenever IGN OFF → ON.
  - The number is fixed to 39 until the self-diagnosis results are erased if it is over 39.

×: Applicable

CONSULT display	Fail-safe	Refer to
No DTC is detected. further testing may be required.	—	—
U1000: CAN COMM CIRCUIT	×	<a href="#">PCS-15</a>
B2098: IGN RELAY ON	×	<a href="#">PCS-16</a>
B2099: IGN RELAY OFF	—	<a href="#">PCS-17</a>
B210B: START CONT RLY ON	—	<a href="#">SEC-79</a>
B210C: START CONT RLY OFF	—	<a href="#">SEC-80</a>
B210D: STARTER RELAY ON	—	<a href="#">SEC-81</a>
B210E: STARTER RELAY OFF	—	<a href="#">SEC-82</a>
B210F: INTRLCK/PNP SW ON	—	<a href="#">SEC-84</a>
B2110: INTRLCK/PNP SW OFF	—	<a href="#">SEC-86</a>

# THE FUEL GAUGE POINTER DOES NOT MOVE

< SYMPTOM DIAGNOSIS >

## SYMPTOM DIAGNOSIS

### THE FUEL GAUGE POINTER DOES NOT MOVE

#### Description

INFOID:0000000006262192

Fuel gauge needle will not move from a certain position.

#### Diagnosis Procedure

INFOID:0000000006262193

#### 1. CHECK FOR THE COMBINATION METER IN SELF-DIAGNOSIS MODE

Check that the fuel gauge needle moves normally by using self-diagnosis function of the combination meter.

Is the inspection result normal?

YES >> GO TO 2.

NO >> Replace combination meter. Refer to [MWI-105. "Removal and Installation"](#).

#### 2. CHECK COMBINATION METER OUTPUT SIGNAL

1. Connect CONSULT-III.

2. Select the "Data Monitor" for the "METER/M&A" and compare the "FUEL METER" monitor value with the fuel gauge reading on the combination meter. Refer to [MWI-46. "Component Function Check"](#).

Does monitor value match fuel gauge reading?

YES >> GO TO 3.

NO >> Replace combination meter.

#### 3. CHECK FUEL LEVEL SENSOR SIGNAL CIRCUIT

Check the fuel level sensor signal circuit. Refer to [MWI-46. "Diagnosis Procedure"](#).

Is the inspection result normal?

YES >> GO TO 4.

NO >> Repair harness or connector.

#### 4. CHECK FUEL LEVEL SENSOR UNIT

Perform a unit check for the fuel level sensor unit. Refer to [MWI-47. "Component Inspection"](#).

Is the inspection result normal?

YES >> GO TO 5.

NO >> Replace fuel level sensor unit. Refer to [FL-6. "Removal and Installation"](#).

#### 5. CHECK FLOAT INTERFERENCE

Check that the float arm interferes with or binds to other components in the fuel tank.

Is the inspection result normal?

YES >> Replace combination meter.

NO >> Repair or replace malfunctioning parts.

A  
B  
C  
D  
E  
F  
G  
H  
I  
J  
K  
L  
M  
O  
P

MWI

# THE METER CONTROL SWITCH IS INOPERATIVE

< SYMPTOM DIAGNOSIS >

---

## THE METER CONTROL SWITCH IS INOPERATIVE

### Description

INFOID:000000006262194

If any of the following malfunctions is found for the meter control switch operation.

- All switches are inoperative.
- The specified switch cannot be operated.

### Diagnosis Procedure

INFOID:000000006262195

#### 1. CHECK METER CONTROL SWITCH SIGNAL CIRCUIT

---

Check the meter control switch signal circuit. Refer to [MWI-49, "Diagnosis Procedure"](#).

Is the inspection result normal?

YES >> GO TO 2.

NO >> Repair harness or connector.

#### 2. CHECK METER CONTROL SWITCH

---

Perform a unit check for the meter control switch. Refer to [MWI-50, "Component Inspection"](#).

Is the inspection result normal?

YES >> Replace combination meter.

NG >> Replace meter control switch.

# THE OIL PRESSURE WARNING LAMP DOES NOT TURN ON

< SYMPTOM DIAGNOSIS >

## THE OIL PRESSURE WARNING LAMP DOES NOT TURN ON

### Description

INFOID:000000006262196

The oil pressure warning lamp stays off when the ignition switch is turned ON.

### Diagnosis Procedure

INFOID:000000006262197

#### 1.CHECK OIL PRESSURE WARNING LAMP

Perform auto active test. Refer to [PCS-10, "Diagnosis Description"](#).

Is oil pressure warning lamp blinking?

- YES >> GO TO 2.
- NO >> GO TO 4.

#### 2.CHECK OIL PRESSURE SWITCH SIGNAL CIRCUIT

Check the oil pressure switch signal circuit. Refer to [MWI-52, "Diagnosis Procedure"](#).

Is the inspection result normal?

- YES >> GO TO 3.
- NO >> Repair harness or connector.

#### 3.CHECK OIL PRESSURE SWITCH

Perform a unit check for the oil pressure switch. Refer to [MWI-52, "Component Inspection"](#).

Is the inspection result normal?

- YES >> Replace IPDM E/R.
- NO >> Replace oil pressure switch.

#### 4.CHECK COMBINATION METER INPUT SIGNAL

Connect CONSULT-III and perform an input signal check for the combination meter. Refer to [MWI-52, "Component Function Check"](#).

Is the inspection result normal?

- YES >> Replace combination meter.
- NO >> Replace IPDM E/R. Refer to [PCS-35, "Removal and Installation"](#).

A  
B  
C  
D  
E  
F  
G  
H  
I  
J  
K  
L  
M  
O  
P

MWI

# THE OIL PRESSURE WARNING LAMP DOES NOT TURN OFF

< SYMPTOM DIAGNOSIS >

## THE OIL PRESSURE WARNING LAMP DOES NOT TURN OFF

### Description

INFOID:000000006262198

The oil pressure warning lamp remains illuminated while the engine is running (normal oil pressure).

### Diagnosis Procedure

INFOID:000000006262199

#### 1. CHECK OIL PRESSURE WARNING LAMP

Perform auto active test. Refer to [PCS-10, "Diagnosis Description"](#).

Is oil pressure warning lamp blinking?

- YES >> GO TO 2.
- NO >> GO TO 5.

#### 2. CHECK IPDM E/R OUTPUT VOLTAGE

1. Turn ignition switch OFF.
2. Disconnect the oil pressure switch connector.
3. Turn ignition switch ON.
4. Check voltage between the oil pressure switch harness connector terminal and ground.

Terminals		Voltage (Approx.)
(+)	(-)	
Oil pressure switch		12 V
Connector	Terminal	
F63	1	

Is the inspection result normal?

- YES >> GO TO 3.
- NO >> GO TO 4.

#### 3. CHECK OIL PRESSURE SWITCH

Perform a unit check for the oil pressure switch. Refer to [MWI-52, "Component Inspection"](#).

Is the inspection result normal?

- YES >> Replace IPDM E/R. Refer to [PCS-35, "Removal and Installation"](#).
- NO >> Replace oil pressure switch.

#### 4. CHECK OIL PRESSURE SWITCH SIGNAL CIRCUIT

Check the oil pressure switch signal circuit. Refer to [MWI-52, "Diagnosis Procedure"](#).

Is the inspection result normal?

- YES >> GO TO 5.
- NO >> Repair harness or connector.

#### 5. CHECK COMBINATION METER INPUT SIGNAL

Connect CONSULT-III and perform an input signal check for the combination meter. Refer to [MWI-52, "Component Function Check"](#).

Is the inspection result normal?

- YES >> Replace combination meter.
- NO >> Replace IPDM E/R. Refer to [PCS-35, "Removal and Installation"](#).



# THE PARKING BRAKE RELEASE WARNING CONTINUES DISPLAYING, OR DOES NOT DISPLAY

< SYMPTOM DIAGNOSIS >

## THE PARKING BRAKE RELEASE WARNING CONTINUES DISPLAYING, OR DOES NOT DISPLAY

### Description

INFOID:000000006262200

- The parking brake warning is displayed during vehicle travel even though the parking brake is released.
- The parking brake warning is not displayed even though driving the vehicle with the parking brake applied.

### Diagnosis Procedure

INFOID:000000006262201

#### 1. CHECK PARKING BRAKE WARNING LAMP OPERATION

1. Start engine.
2. Check the operation of the parking brake warning lamp when operating the parking brake.

Condition	Warning lamp status
When parking brake is applied	ON
When parking brake is released	OFF

Is the inspection result normal?

- YES >> Replace combination meter.
- NO >> GO TO 2.

#### 2. CHECK PARKING BRAKE SWITCH SIGNAL CIRCUIT

1. Turn ignition switch OFF.
2. Check the parking brake switch signal circuit. Refer to [MWI-54, "Diagnosis Procedure"](#).

Is the inspection result normal?

- YES >> GO TO 3.
- NG >> Repair harness or connector.

#### 3. CHECK PARKING BRAKE SWITCH

Perform a unit check for the parking brake switch. Refer to [MWI-54, "Component Inspection"](#).

Is the inspection result normal?

- YES >> Replace combination meter.
- NO >> Replace parking brake switch.

A  
B  
C  
D  
E  
F  
G  
H  
I  
J  
K  
L  
M  
O  
P

MWI

# THE LOW WASHER FLUID WARNING CONTINUES DISPLAYING, OR DOES NOT DISPLAY

< SYMPTOM DIAGNOSIS >

---

## THE LOW WASHER FLUID WARNING CONTINUES DISPLAYING, OR DOES NOT DISPLAY

### Description

INFOID:000000006262202

- The warning is still displayed even after washer fluid is added.
- The warning is not displayed even though the washer tank is empty.

### Diagnosis Procedure

INFOID:000000006262203

#### 1.CHECK WASHER LEVEL SWITCH SIGNAL CIRCUIT

---

Check the washer level switch signal circuit. Refer to [MWI-55. "Diagnosis Procedure"](#).

Is the inspection result normal?

- YES >> GO TO 2.  
NO >> Repair harness or connector.

#### 2.CHECK WASHER LEVEL SWITCH

---

Perform a unit check for the washer level switch. Refer to [MWI-55. "Component Inspection"](#).

Is the inspection result normal?

- YES >> Replace combination meter.  
NO >> Replace washer level switch. Refer to [WW-113. "Removal and Installation"](#).

# THE DOOR OPEN WARNING CONTINUES DISPLAYING, OR DOES NOT DISPLAY

< SYMPTOM DIAGNOSIS >

## THE DOOR OPEN WARNING CONTINUES DISPLAYING, OR DOES NOT DISPLAY

### Description

INFOID:00000000626204

- The door ajar warning is displayed even though all of the doors are closed.
- The door ajar warning is not displayed even though a door is ajar.

### Diagnosis Procedure

INFOID:00000000626205

#### 1. CHECK BCM INPUT/OUTPUT SIGNAL

Connect CONSULT-III and check the BCM input signals. Refer to [DLK-97, "WITH AUTOMATIC BACK DOOR : Component Function Check"](#) (with automatic back door) or [DLK-100, "WITHOUT AUTOMATIC BACK DOOR : Component Function Check"](#) (without automatic back door).

Is the inspection result normal?

- YES >> GO TO 2.
- NO >> GO TO 3.

#### 2. CHECK COMBINATION METER INPUT SIGNAL

Select the "Data Monitor" for the "METER/M&A" and check the "DOOR W/L" monitor value.

"DOOR W/L"

Door open : On  
Door closed : Off

Is the inspection result normal?

- YES >> Replace combination meter.
- NO >> Replace BCM. Refer to [BCS-85, "Removal and Installation"](#).

#### 3. CHECK DOOR SWITCH SIGNAL CIRCUIT

Check the door switch signal circuit. Refer to [DLK-97, "WITH AUTOMATIC BACK DOOR : Diagnosis Procedure"](#) (with automatic back door) or [DLK-100, "WITHOUT AUTOMATIC BACK DOOR : Diagnosis Procedure"](#) (without automatic back door).

Is the inspection result normal?

- YES >> GO TO 4.
- NO >> Repair harness or connector.

#### 4. CHECK DOOR SWITCH

Perform a unit check for the door switch. Refer to [DLK-99, "WITH AUTOMATIC BACK DOOR : Component Inspection"](#) (with automatic back door) or [DLK-102, "WITHOUT AUTOMATIC BACK DOOR : Component Inspection"](#) (without automatic back door).

Is the inspection result normal?

- YES >> Replace combination meter.
- NO >> Replace applicable door switch. Refer to [DLK-348, "Removal and Installation"](#).

A  
B  
C  
D  
E  
F  
G  
H  
I  
J  
K  
L  
M  
MWI  
O  
P

# THE AMBIENT TEMPERATURE DISPLAY IS INCORRECT

< SYMPTOM DIAGNOSIS >

---

## THE AMBIENT TEMPERATURE DISPLAY IS INCORRECT

### Description

INFOID:000000006262206

- The displayed ambient air temperature is higher than the actual temperature.
- The displayed ambient air temperature is lower than the actual temperature.

### Diagnosis Procedure

INFOID:000000006262207

#### NOTE:

Check that the symptom is not applicable to the normal operating condition before starting diagnosis. Refer to [MWI-101. "INFORMATION DISPLAY : Description"](#).

#### 1.CHECK AMBIENT SENSOR SIGNAL CIRCUIT

---

Check the ambient sensor signal circuit. Refer to [HAC-46. "Diagnosis Procedure"](#) (without 7 inch display) or [HAC-173. "Diagnosis Procedure"](#) (with 7 inch display).

Is the inspection result normal?

YES >> GO TO 2.

NO >> Repair harness or connector.

#### 2.CHECK A/C AUTO AMP. CONNECTION RECOGNITION SIGNAL CIRCUIT

---

Check the A/C auto amp. connection recognition signal circuit. Refer to [MWI-56. "Diagnosis Procedure"](#).

Is the inspection result normal?

YES >> GO TO 3.

NO >> Repair harness or connector.

#### 3.CHECK AMBIENT SENSOR

---

Perform a unit check for the ambient sensor. Refer to [HAC-47. "Component Inspection"](#) (without 7 inch display) or [HAC-174. "Component Inspection"](#) (with 7 inch display).

Is the inspection result normal?

YES >> Replace combination meter.

NO >> Replace ambient sensor. Refer to [VTL-26. "Removal and Installation"](#) (without 7 inch display) or [VTL-88. "Removal and Installation"](#) (with 7 inch display).

# NORMAL OPERATING CONDITION

< SYMPTOM DIAGNOSIS >

## NORMAL OPERATING CONDITION COMPASS

### COMPASS : Description

INFOID:000000006262208

#### COMPASS

- The electronic compass is highly protected from changes in most magnetic fields. However, some large changes in magnetic fields can affect it. Some examples are (but not limited to): high tension power lines, large steel buildings, subways, steel bridges, automatic car washes, large piles of scrap metal, etc. While this does not happen very often, it is possible.
- During normal operation, the compass mirror will continuously update the compass calibration to adjust for gradual changes in the vehicle's magnetic "remnant" field. If the vehicle is subjected to high magnetic influences, the compass may appear to indicate false headings, become locked, or appear that it is unable to be calibrated. If this occurs, perform the calibration procedure.
- If at any time the compass continually displays an incorrect direction or the reading is erratic or locked, verify the correct zone variance.

#### Symptom Chart

Symptom	Cause	Solution / Reference
The compass display reads "C".	<ul style="list-style-type: none"><li>• Compass is not calibrated.</li><li>• Incorrect zone variance setting.</li><li>• Large change in magnetic field (Steel bridges, subways, concentrations of metal, carwashes, etc.)</li><li>• Compass was calibrated incorrectly or in the presence of a strong magnetic field.</li></ul>	Perform Calibration. Refer to <a href="#">MWI-32, "Description"</a> .
Compass shows the wrong direction.		
Compass does not change direction appears "Locked".		
Compass does not show all the directions, one or more is missing.		
The compass was calibrated but it "loses" calibration.		
On long trips the compass shows the wrong direction.	Perform zone variation setting if correct reading is desired in that location. Refer to <a href="#">MWI-32, "Description"</a> .	

## INFORMATION DISPLAY

### INFORMATION DISPLAY : Description

INFOID:000000006262209

#### AMBIENT AIR TEMPERATURE

The displayed ambient air temperature on the information display may differ from the actual temperature because it is a corrected value calculated from the ambient sensor signal by the combination meter. Refer to [MWI-26, "INFORMATION DISPLAY : System Description"](#) for details on the correction process.

#### POSSIBLE DRIVING DISTANCE

The calculated possible driving distance may differ from the actual distance to empty if the refueling amount is approximately 15 ℓ (4 US gal, 3-1/4 Imp gal) or less. This is because the refuel control (moves the fuel gauge needle quicker than normal judging that the driver is refueling the vehicle) is not performing.

A  
B  
C  
D  
E  
F  
G  
H  
I  
J  
K  
L  
M  
O  
P

MWI

# PRECAUTIONS

< PRECAUTION >

## PRECAUTION

### PRECAUTIONS

#### FOR USA AND CANADA

#### FOR USA AND CANADA : Precaution for Supplemental Restraint System (SRS) "AIR BAG" and "SEAT BELT PRE-TENSIONER"

INFOID:0000000062622.10

The Supplemental Restraint System such as "AIR BAG" and "SEAT BELT PRE-TENSIONER", used along with a front seat belt, helps to reduce the risk or severity of injury to the driver and front passenger for certain types of collision. This system includes seat belt switch inputs and dual stage front air bag modules. The SRS system uses the seat belt switches to determine the front air bag deployment, and may only deploy one front air bag, depending on the severity of a collision and whether the front occupants are belted or unbelted.

Information necessary to service the system safely is included in the "SRS AIR BAG" and "SEAT BELT" of this Service Manual.

#### **WARNING:**

**Always observe the following items for preventing accidental activation.**

- **To avoid rendering the SRS inoperative, which could increase the risk of personal injury or death in the event of a collision that would result in air bag inflation, all maintenance must be performed by an authorized NISSAN/INFINITI dealer.**
- **Improper maintenance, including incorrect removal and installation of the SRS, can lead to personal injury caused by unintentional activation of the system. For removal of Spiral Cable and Air Bag Module, see "SRS AIR BAG".**
- **Never use electrical test equipment on any circuit related to the SRS unless instructed to in this Service Manual. SRS wiring harnesses can be identified by yellow and/or orange harnesses or harness connectors.**

#### PRECAUTIONS WHEN USING POWER TOOLS (AIR OR ELECTRIC) AND HAMMERS

#### **WARNING:**

**Always observe the following items for preventing accidental activation.**

- **When working near the Air Bag Diagnosis Sensor Unit or other Air Bag System sensors with the ignition ON or engine running, never use air or electric power tools or strike near the sensor(s) with a hammer. Heavy vibration could activate the sensor(s) and deploy the air bag(s), possibly causing serious injury.**
- **When using air or electric power tools or hammers, always switch the ignition OFF, disconnect the battery, and wait at least 3 minutes before performing any service.**

#### FOR MEXICO

#### FOR MEXICO : Precaution for Supplemental Restraint System (SRS) "AIR BAG" and "SEAT BELT PRE-TENSIONER"

INFOID:0000000062622.11

The Supplemental Restraint System such as "AIR BAG" and "SEAT BELT PRE-TENSIONER", used along with a front seat belt, helps to reduce the risk or severity of injury to the driver and front passenger for certain types of collision. Information necessary to service the system safely is included in the "SRS AIR BAG" and "SEAT BELT" of this Service Manual.

#### **WARNING:**

**Always observe the following items for preventing accidental activation.**

- **To avoid rendering the SRS inoperative, which could increase the risk of personal injury or death in the event of a collision that would result in air bag inflation, all maintenance must be performed by an authorized NISSAN/INFINITI dealer.**
- **Improper maintenance, including incorrect removal and installation of the SRS, can lead to personal injury caused by unintentional activation of the system. For removal of Spiral Cable and Air Bag Module, see "SRS AIR BAG".**
- **Never use electrical test equipment on any circuit related to the SRS unless instructed to in this Service Manual. SRS wiring harnesses can be identified by yellow and/or orange harnesses or harness connectors.**

#### PRECAUTIONS WHEN USING POWER TOOLS (AIR OR ELECTRIC) AND HAMMERS

#### **WARNING:**

## PRECAUTIONS

### < PRECAUTION >

---

Always observe the following items for preventing accidental activation.

- When working near the Air Bag Diagnosis Sensor Unit or other Air Bag System sensors with the ignition ON or engine running, never use air or electric power tools or strike near the sensor(s) with a hammer. Heavy vibration could activate the sensor(s) and deploy the air bag(s), possibly causing serious injury.
- When using air or electric power tools or hammers, always switch the ignition OFF, disconnect the battery, and wait at least 3 minutes before performing any service.

A

B

C

D

E

F

G

H

I

J

K

L

M

MWI

O

P

# PREPARATION

< PREPARATION >

## PREPARATION

### PREPARATION

#### Commercial Service Tools

INFOID:000000006262212

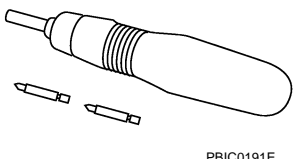
Tool name	Description
<p data-bbox="162 514 267 546">Power tool</p>  <p data-bbox="828 630 901 651">PBIC0191E</p>	<p data-bbox="1006 514 1193 546">Loosening screws</p>



# COMBINATION METER

< REMOVAL AND INSTALLATION >

## REMOVAL AND INSTALLATION

### COMBINATION METER

#### Exploded View

INFOID:000000006262213

Refer to [IP-12, "Exploded View"](#).

#### DISASSEMBLY

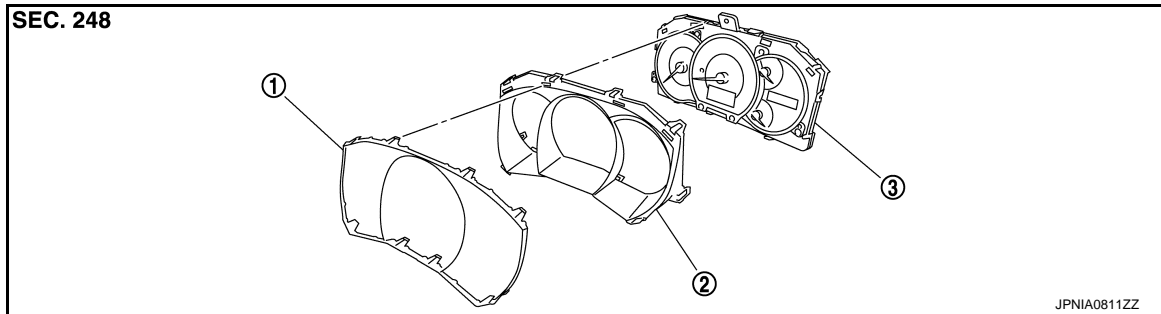

1. Front cover

2. Upper housing

3. Unified meter control unit

#### Removal and Installation

INFOID:000000006262214

#### REMOVAL

##### Removal

1. Remove the cluster lid A. Refer to [IP-13, "Removal and Installation"](#).
2. Remove screws (A) and connector, and remove combination meter (1).

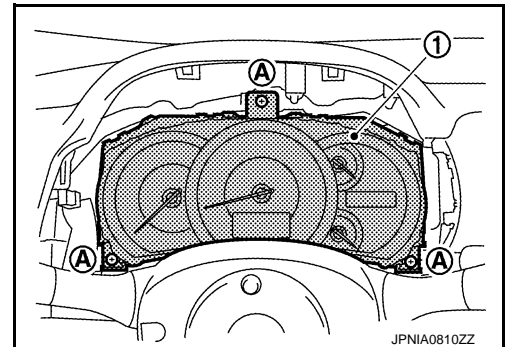

#### INSTALLATION

Install in the reverse order of removal.

#### Disassembly and Assembly

INFOID:000000006262215

#### DISASSEMBLY

1. Disengage the tabs to separate upper housing.
2. Disengage the tabs to separate front cover.

#### ASSEMBLY

Assemble in the reverse order of disassembly.

A  
B  
C  
D  
E  
F  
G  
H  
I  
J  
K  
L  
M  
N  
O  
P

# METER CONTROL SWITCH

< REMOVAL AND INSTALLATION >

## METER CONTROL SWITCH

Exploded View

INFOID:000000006262216

### REMOVAL

Refer to [IP-12. "Exploded View"](#).

### DISASSEMBLY

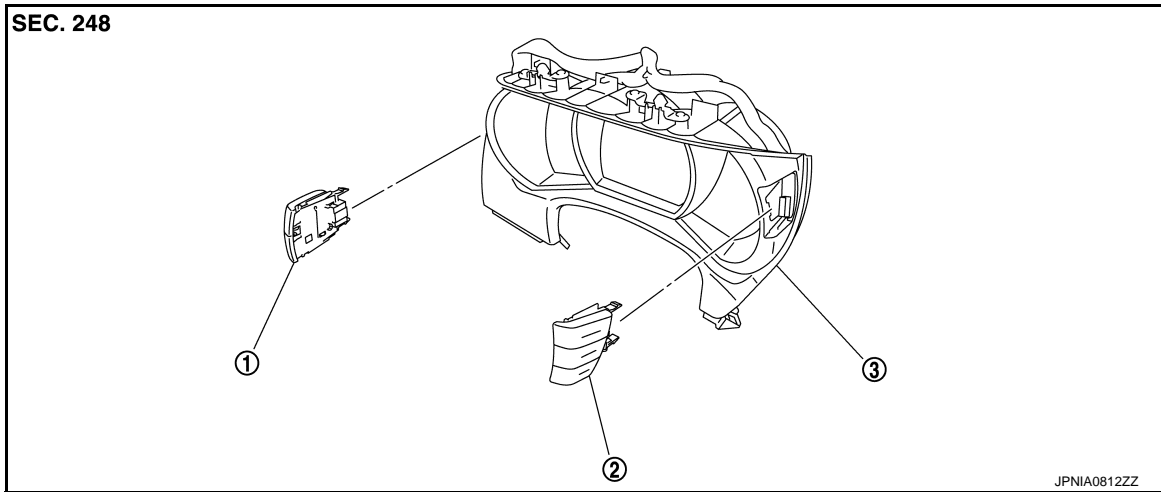

1. Meter control switch (LH)

2. Meter control switch (RH)

3. Cluster lid A

### Removal and Installation

INFOID:000000006262217

### REMOVAL

1. Remove cluster lid A. Refer to [IP-12. "Exploded View"](#).
2. Remove meter control switch connectors and remove meter control switches.

### INSTALLATION

Install in the reverse order of removal.

# COMPASS

< REMOVAL AND INSTALLATION >

## COMPASS

---

### Exploded View

INFOID:000000006262218

Refer to [MIR-69. "Exploded View"](#) (with ADP) or [MIR-91. "Exploded View"](#) (without ADP).

### Removal and Installation

INFOID:000000006262219

Refer to [MIR-69. "Removal and Installation"](#) (with ADP) or [MIR-91. "Removal and Installation"](#) (without ADP).

A  
B  
C  
D  
E  
F  
G  
H  
I  
J  
K  
L  
M  
O  
P

MWI