

SECTION **BR**
BRAKE SYSTEM

A
B
C
D
E

CONTENTS

<p>SYMPTOM DIAGNOSIS 3</p> <p>NOISE, VIBRATION AND HARSHNESS (NVH) TROUBLESHOOTING 3</p> <p style="padding-left: 20px;">NVH Troubleshooting Chart3</p> <p>PRECAUTION 4</p> <p>PRECAUTIONS 4</p> <p>FOR USA AND CANADA4</p> <p style="padding-left: 20px;">FOR USA AND CANADA : Precaution for Supplemental Restraint System (SRS) "AIR BAG" and "SEAT BELT PRE-TENSIONER"4</p> <p style="padding-left: 20px;">FOR USA AND CANADA : Precaution for Procedure without Cowl Top Cover4</p> <p style="padding-left: 20px;">FOR USA AND CANADA : Precaution for Brake System4</p> <p>FOR MEXICO5</p> <p style="padding-left: 20px;">FOR MEXICO : Precaution for Supplemental Restraint System (SRS) "AIR BAG" and "SEAT BELT PRE-TENSIONER"5</p> <p style="padding-left: 20px;">FOR MEXICO : Precaution for Procedure without Cowl Top Cover6</p> <p style="padding-left: 20px;">FOR MEXICO : Precaution for Brake System6</p> <p>PREPARATION 7</p> <p>PREPARATION 7</p> <p style="padding-left: 20px;">Commercial Service Tool7</p> <p>PERIODIC MAINTENANCE 8</p> <p>BRAKE PEDAL 8</p> <p style="padding-left: 20px;">Inspection and Adjustment8</p> <p>BRAKE FLUID11</p> <p style="padding-left: 20px;">Inspection 11</p> <p style="padding-left: 20px;">Draining 11</p> <p style="padding-left: 20px;">Refilling 11</p> <p style="padding-left: 20px;">Bleeding Brake System12</p>	<p>BRAKE MASTER CYLINDER13</p> <p style="padding-left: 20px;">Inspection13</p> <p>BRAKE BOOSTER14</p> <p style="padding-left: 20px;">Inspection14</p> <p>FRONT DISC BRAKE15</p> <p>BRAKE PAD15</p> <p style="padding-left: 20px;">BRAKE PAD : Inspection and Adjustment15</p> <p>DISC ROTOR15</p> <p style="padding-left: 20px;">DISC ROTOR : Inspection and Adjustment15</p> <p>REAR DISC BRAKE17</p> <p>BRAKE PAD17</p> <p style="padding-left: 20px;">BRAKE PAD : Inspection and Adjustment17</p> <p>DISC ROTOR17</p> <p style="padding-left: 20px;">DISC ROTOR : Inspection and Adjustment17</p> <p>REMOVAL AND INSTALLATION19</p> <p>BRAKE PEDAL19</p> <p style="padding-left: 20px;">Exploded View19</p> <p style="padding-left: 20px;">Removal and Installation19</p> <p style="padding-left: 20px;">Inspection and Adjustment20</p> <p>BRAKE PIPING21</p> <p>FRONT21</p> <p style="padding-left: 20px;">FRONT : Exploded View21</p> <p style="padding-left: 20px;">FRONT : Hydraulic Piping22</p> <p style="padding-left: 20px;">FRONT : Removal and Installation22</p> <p style="padding-left: 20px;">FRONT : Inspection23</p> <p>REAR23</p> <p style="padding-left: 20px;">REAR : Exploded View23</p> <p style="padding-left: 20px;">REAR : Hydraulic Piping24</p> <p style="padding-left: 20px;">REAR : Removal and Installation24</p> <p style="padding-left: 20px;">REAR : Inspection25</p> <p>BRAKE MASTER CYLINDER26</p>
---	---

BR

G

H

I

J

K

L

M

N

O

P

Exploded View	26	BRAKE CALIPER ASSEMBLY (2 PISTON TYPE)...	41
Removal and Installation	26	BRAKE CALIPER ASSEMBLY (2 PISTON TYPE)	
Disassembly and Assembly	27	: Exploded View	41
Inspection	28	BRAKE CALIPER ASSEMBLY (2 PISTON TYPE)	
BRAKE BOOSTER	29	: Removal and Installation	42
Exploded View	29	BRAKE CALIPER ASSEMBLY (2 PISTON TYPE)	
Removal and installation	29	: Disassembly and Assembly	43
Inspection and Adjustment	30	BRAKE CALIPER ASSEMBLY (2 PISTON TYPE)	
		: Inspection	45
VACUUM LINES	32	REAR DISC BRAKE	46
Exploded View	32	BRAKE PAD	46
Removal and Installation	32	BRAKE PAD : Exploded View	46
Inspection	32	BRAKE PAD : Removal and Installation	46
		BRAKE PAD : Inspection	47
FRONT DISC BRAKE	34	BRAKE CALIPER ASSEMBLY	47
BRAKE PAD (1 PISTON TYPE)	34	BRAKE CALIPER ASSEMBLY : Exploded View ...	47
BRAKE PAD (1 PISTON TYPE) : Exploded View...	34	BRAKE CALIPER ASSEMBLY : Removal and In-	
BRAKE PAD (1 PISTON TYPE) : Removal and In-		stallation	48
stallation	34	BRAKE CALIPER ASSEMBLY : Disassembly and	
BRAKE PAD (1 PISTON TYPE) : Inspection	35	Assembly	49
		BRAKE CALIPER ASSEMBLY : Inspection	51
BRAKE PAD (2 PISTON TYPE)	35	SERVICE DATA AND SPECIFICATIONS	
BRAKE PAD (2 PISTON TYPE) : Exploded View...	36	(SDS)	52
BRAKE PAD (2 PISTON TYPE) : Removal and In-		SERVICE DATA AND SPECIFICATIONS	
stallation	36	(SDS)	52
BRAKE PAD (2 PISTON TYPE) : Inspection	37	General Specifications	52
		Brake Pedal	52
BRAKE CALIPER ASSEMBLY (1 PISTON TYPE)...	37	Brake Booster	53
BRAKE CALIPER ASSEMBLY (1 PISTON TYPE)		Front Disc Brake	53
: Exploded View	37	Rear Disc Brake	53
BRAKE CALIPER ASSEMBLY (1 PISTON TYPE)			
: Removal and Installation	38		
BRAKE CALIPER ASSEMBLY (1 PISTON TYPE)			
: Disassembly and Assembly	39		
BRAKE CALIPER ASSEMBLY (1 PISTON TYPE)			
: Inspection	41		

PRECAUTIONS

< PRECAUTION >

PRECAUTION

PRECAUTIONS

FOR USA AND CANADA

FOR USA AND CANADA : Precaution for Supplemental Restraint System (SRS) "AIR BAG" and "SEAT BELT PRE-TENSIONER"

INFOID:000000007803649

The Supplemental Restraint System such as "AIR BAG" and "SEAT BELT PRE-TENSIONER", used along with a front seat belt, helps to reduce the risk or severity of injury to the driver and front passenger for certain types of collision. This system includes seat belt switch inputs and dual stage front air bag modules. The SRS system uses the seat belt switches to determine the front air bag deployment, and may only deploy one front air bag, depending on the severity of a collision and whether the front occupants are belted or unbelted. Information necessary to service the system safely is included in the "SRS AIR BAG" and "SEAT BELT" of this Service Manual.

WARNING:

Always observe the following items for preventing accidental activation.

- To avoid rendering the SRS inoperative, which could increase the risk of personal injury or death in the event of a collision that would result in air bag inflation, all maintenance must be performed by an authorized NISSAN/INFINITI dealer.
- Improper maintenance, including incorrect removal and installation of the SRS, can lead to personal injury caused by unintentional activation of the system. For removal of Spiral Cable and Air Bag Module, see "SRS AIR BAG".
- Never use electrical test equipment on any circuit related to the SRS unless instructed to in this Service Manual. SRS wiring harnesses can be identified by yellow and/or orange harnesses or harness connectors.

PRECAUTIONS WHEN USING POWER TOOLS (AIR OR ELECTRIC) AND HAMMERS

WARNING:

Always observe the following items for preventing accidental activation.

- When working near the Air Bag Diagnosis Sensor Unit or other Air Bag System sensors with the ignition ON or engine running, never use air or electric power tools or strike near the sensor(s) with a hammer. Heavy vibration could activate the sensor(s) and deploy the air bag(s), possibly causing serious injury.
- When using air or electric power tools or hammers, always switch the ignition OFF, disconnect the battery, and wait at least 3 minutes before performing any service.

FOR USA AND CANADA : Precaution for Procedure without Cowl Top Cover

INFOID:000000007803651

When performing the procedure after removing cowl top cover, cover the lower end of windshield with urethane, etc to prevent damage to windshield.

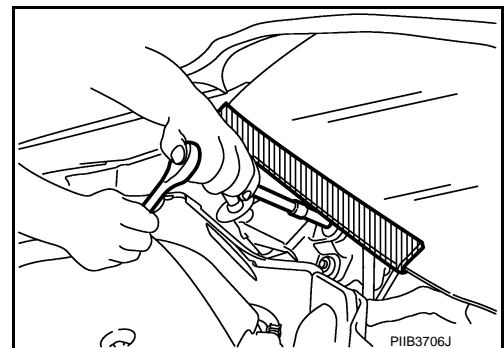

FOR USA AND CANADA : Precaution for Brake System

INFOID:000000007543240

WARNING:

Since dust covering the front and rear brakes has an affect on human body, the dust must be removed with a dust collector. Never splatter the dust with an air blow gun.

CAUTION:

- Brake fluid use refer to [MA-16, "FOR NORTH AMERICA : Fluids and Lubricants"](#).
- Never reuse drained brake fluid.

PRECAUTIONS

< PRECAUTION >

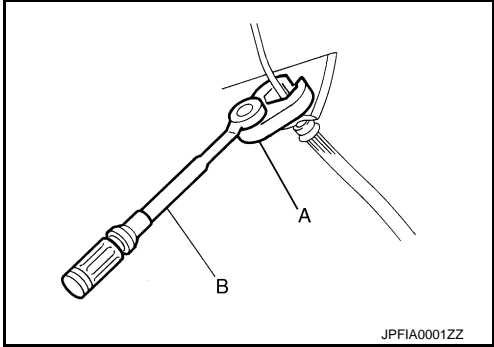
- Never spill or splash brake fluid on painted surfaces. Brake fluid may seriously damage paint. Wipe it off immediately and wash with water if it gets on a painted surface.
 - Always clean with new brake fluid when cleaning the master cylinder, brake caliper and other components.
 - Never use mineral oils such as gasoline or light oil to clean. They may damage rubber parts and cause improper operation.
 - Always loosen the brake tube flare nut with a flare nut wrench.
 - Tighten the brake tube flare nut to the specified torque with crowfoot (A) and torque wrench (B).
 - Always confirm the specified tightening torque when installing the brake pipes.
 - Turn the ignition switch OFF and disconnect the ABS actuator and electric unit (control unit) connector or the battery negative terminal before performing the work.
 - Check that no brake fluid leakage is present after replacing the parts.
 - Burnish the brake contact surfaces after refinishing or replacing rotors, after replacing pads, or if a soft pedal occurs at very low mileage.
- 
- Front brake pad: refer to [BR-15, "BRAKE PAD : Inspection and Adjustment"](#).
 - Front disc rotor: refer to [BR-15, "DISC ROTOR : Inspection and Adjustment"](#).
 - Rear brake pad: refer to [BR-17, "BRAKE PAD : Inspection and Adjustment"](#).
 - Rear disc rotor: refer to [BR-17, "DISC ROTOR : Inspection and Adjustment"](#).

FOR MEXICO

FOR MEXICO : Precaution for Supplemental Restraint System (SRS) "AIR BAG" and "SEAT BELT PRE-TENSIONER"

INFOID:000000007803650

The Supplemental Restraint System such as "AIR BAG" and "SEAT BELT PRE-TENSIONER", used along with a front seat belt, helps to reduce the risk or severity of injury to the driver and front passenger for certain types of collision. Information necessary to service the system safely is included in the "SRS AIR BAG" and "SEAT BELT" of this Service Manual.

WARNING:

Always observe the following items for preventing accidental activation.

- To avoid rendering the SRS inoperative, which could increase the risk of personal injury or death in the event of a collision that would result in air bag inflation, all maintenance must be performed by an authorized NISSAN/INFINITI dealer.
- Improper maintenance, including incorrect removal and installation of the SRS, can lead to personal injury caused by unintentional activation of the system. For removal of Spiral Cable and Air Bag Module, see "SRS AIR BAG".
- Never use electrical test equipment on any circuit related to the SRS unless instructed to in this Service Manual. SRS wiring harnesses can be identified by yellow and/or orange harnesses or harness connectors.

PRECAUTIONS WHEN USING POWER TOOLS (AIR OR ELECTRIC) AND HAMMERS

WARNING:

Always observe the following items for preventing accidental activation.

- When working near the Air Bag Diagnosis Sensor Unit or other Air Bag System sensors with the ignition ON or engine running, never use air or electric power tools or strike near the sensor(s) with a hammer. Heavy vibration could activate the sensor(s) and deploy the air bag(s), possibly causing serious injury.
- When using air or electric power tools or hammers, always switch the ignition OFF, disconnect the battery, and wait at least 3 minutes before performing any service.

PRECAUTIONS

< PRECAUTION >

FOR MEXICO : Precaution for Procedure without Cowl Top Cover

INFOID:000000007803652

When performing the procedure after removing cowl top cover, cover the lower end of windshield with urethane, etc to prevent damage to windshield.

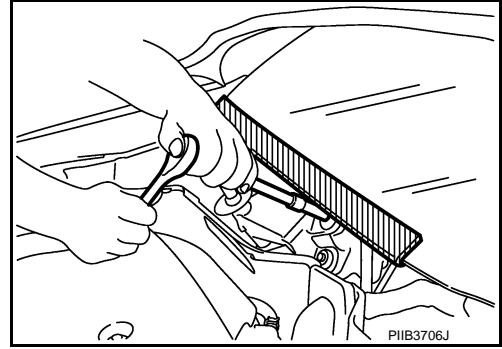

FOR MEXICO : Precaution for Brake System

INFOID:000000007543243

WARNING:

Since dust covering the front and rear brakes has an affect on human body, the dust must be removed with a dust collector. Never splatter the dust with an air blow gun.

CAUTION:

- Brake fluid use refer to [MA-17, "FOR MEXICO : Fluids and Lubricants"](#).
 - Never reuse drained brake fluid.
 - Never spill or splash brake fluid on painted surfaces. Brake fluid may seriously damage paint. Wipe it off immediately and wash with water if it gets on a painted surface.
 - Always clean with new brake fluid when cleaning the master cylinder, brake caliper and other components.
 - Never use mineral oils such as gasoline or light oil to clean. They may damage rubber parts and cause improper operation.
 - Always loosen the brake tube flare nut with a flare nut wrench.
 - Tighten the brake tube flare nut to the specified torque with crowfoot (A) and torque wrench (B).
 - Always confirm the specified tightening torque when installing the brake pipes.
 - Turn the ignition switch OFF and disconnect the ABS actuator and electric unit (control unit) connector or the battery negative terminal before performing the work.
 - Check that no brake fluid leakage is present after replacing the parts.
 - Burnish the brake contact surfaces after refinishing or replacing rotors, after replacing pads, or if a soft pedal occurs at very low mileage.
- Front brake pad: refer to [BR-15, "BRAKE PAD : Inspection and Adjustment"](#).
 - Front disc rotor: refer to [BR-15, "DISC ROTOR : Inspection and Adjustment"](#).
 - Rear brake pad: refer to [BR-17, "BRAKE PAD : Inspection and Adjustment"](#).
 - Rear disc rotor: refer to [BR-17, "DISC ROTOR : Inspection and Adjustment"](#).

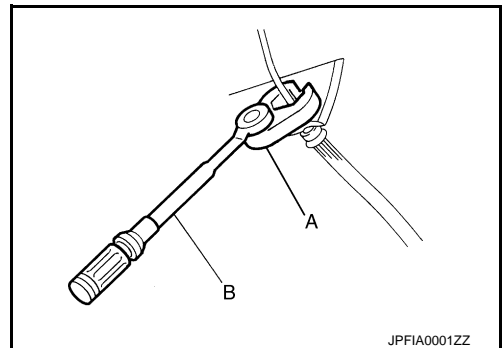

PREPARATION

< PREPARATION >

PREPARATION

PREPARATION

Commercial Service Tool

INFOID:000000007543244

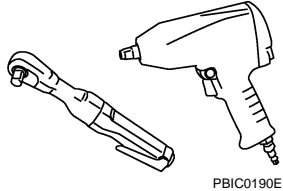
Tool name	Description
Power tool 	Loosening bolts and nuts

A

B

C

D

E

BR

G

H

I

J

K

L

M

N

O

P

BRAKE PEDAL

< PERIODIC MAINTENANCE >

PERIODIC MAINTENANCE

BRAKE PEDAL

Inspection and Adjustment

INFOID:000000007543245

INSPECTION

Brake Pedal Height

Check the brake pedal height (H_1) between the dash lower panel (1) and the brake pedal upper surface.

Standard

H_1

: Refer to [BR-52, "Brake Pedal"](#).

CAUTION:

Remove the floor trim.

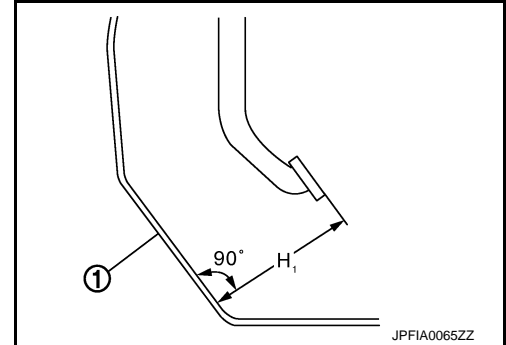

Stop Lamp Switch and ASCD Brake Switch

Check the clearance (C) between stopper rubber (1) and stop lamp switch and ASCD brake switch (2) threaded end.

Standard

C

: Refer to [BR-52, "Brake Pedal"](#).

CAUTION:

The stop lamp must be turned off when the brake pedal is released.

NOTE:

Pull the brake pedal pad to make the clearance between stopper rubber and stop lamp switch and ASCD brake switch threaded end.

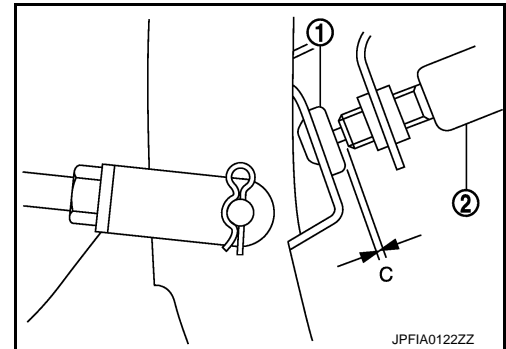

Brake Pedal Play

Press the brake pedal. Check the brake pedal play (A).

Standard

A

: Refer to [BR-52, "Brake Pedal"](#).

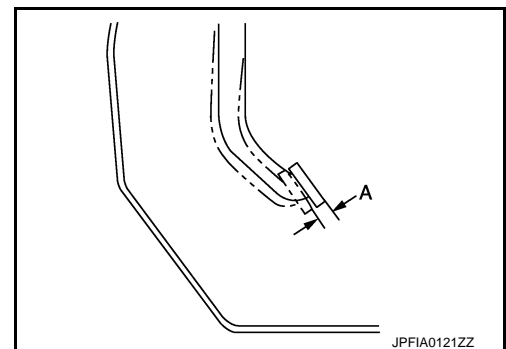

Depressed Brake Pedal Height

Check the brake pedal height (H_2) between the dash lower panel (1) and the brake pedal upper surface when depressing the brake pedal at 490 N (50 kg, 110 lb) while turning engine ON.

Standard

H_2

: Refer to [BR-52, "Brake Pedal"](#).

CAUTION:

Remove the floor trim.

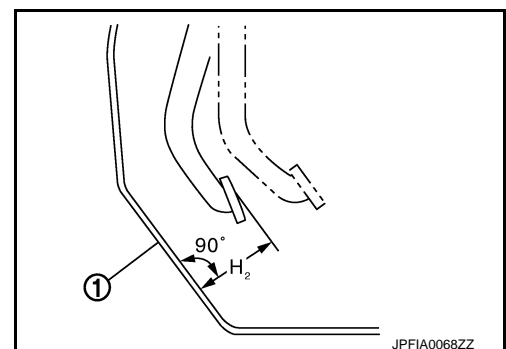

BRAKE PEDAL

< PERIODIC MAINTENANCE >

ADJUSTMENT

Brake Pedal Height

1. Remove instrument lower panel LH. Refer to [IP-12, "Exploded View"](#).
2. Disconnect the stop lamp switch and ASCD brake switch harness connector.
3. Turn the stop lamp switch and ASCD brake switch 45° counterclockwise.
4. Loosen the input rod lock nut (1). Adjust the brake pedal height (H_1) to the specification. Tighten the input rod lock nut to the specification. Refer to [BR-29, "Exploded View"](#).

CAUTION:

The threaded end of the input rod (2) must project to the inner side (L) of the clevis (3).

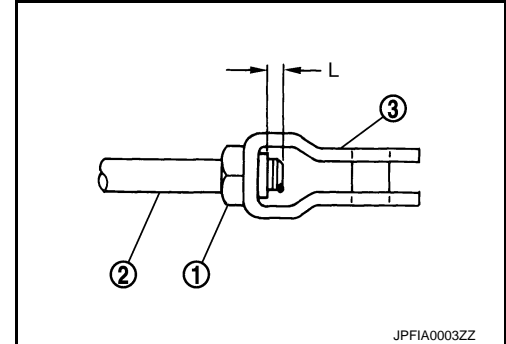

Standard

H_1

: Refer to [BR-52, "Brake Pedal"](#).

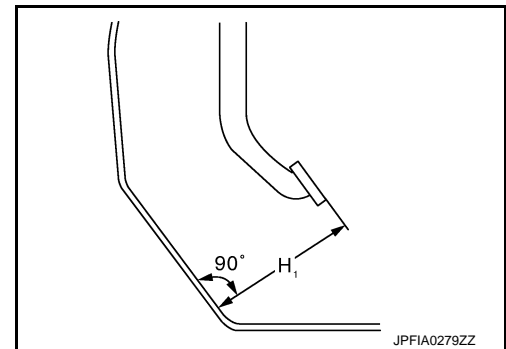

Stop Lamp Switch and ASCD Brake Switch

1. Remove instrument lower panel LH. Refer to [IP-12, "Exploded View"](#).
2. Disconnect the stop lamp switch and ASCD brake switch harness connector.
3. Turn the stop lamp switch and ASCD brake switch 45° counterclockwise.
4. Press-fit stop lamp switch and ASCD brake switch (2) until stop lamp switch and ASCD brake switch hits the stopper rubber (1) 45° clockwise.

CAUTION:

- The clearance (C) between the stopper rubber and stop lamp switch and ASCD brake switch threaded end must be the specified value. Refer to [BR-52, "Brake Pedal"](#).
- The stop lamp must be turned off when the brake pedal is released.

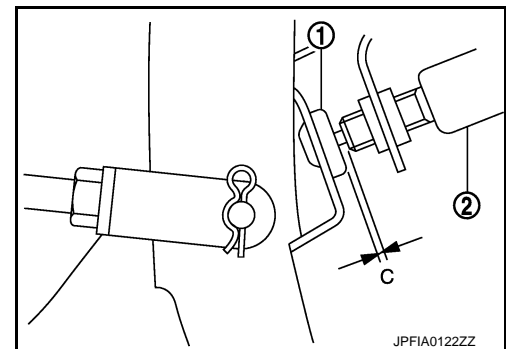

Brake Pedal Play

1. Remove instrument lower panel LH. Refer to [IP-12, "Exploded View"](#).
2. Disconnect the stop lamp switch and ASCD brake switch harness connector.
3. Turn the stop lamp switch and ASCD brake switch 45° counterclockwise.

BRAKE PEDAL

< PERIODIC MAINTENANCE >

4. Press-fit stop lamp switch and ASCD brake switch (2) until stop lamp switch and ASCD brake switch hits the stopper rubber (1) 45° clockwise.

CAUTION:

- The clearance (C) between the stopper rubber and stop lamp switch and ASCD brake switch threaded end must be the specified value. Refer to [BR-52. "Brake Pedal"](#).
- The stop lamp must be turned off when the brake pedal is released.

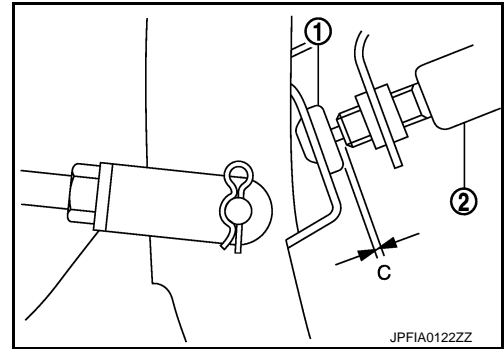

BRAKE FLUID

< PERIODIC MAINTENANCE >

BRAKE FLUID

Inspection

INFOID:000000007543246

BRAKE FLUID LEVEL

- Check that the fluid level in the sub tank is within the specified range (MAX – MIN lines).
- Visually check for any brake fluid leakage around the sub tank, reservoir tank and hose.
- Check the brake system for any leakage if the fluid level is extremely low (lower than MIN).
- Check the brake system for fluid leakage if the warning lamp remains illuminated even after the parking brake is released.

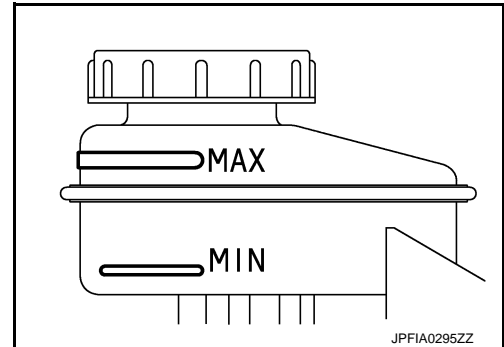

BRAKE LINE

1. Check brake line (tubes and hoses) for cracks, deterioration or other damage. Replace any damaged parts.
2. Check for fluid leakage by fully depressing brake pedal while engine is running.

CAUTION:

If leakage occurs around joints, retighten or, if necessary, replace damaged parts.

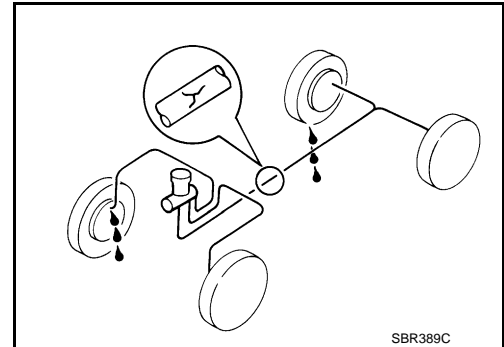

Draining

INFOID:000000007543247

CAUTION:

- **Never spill or splash brake fluid on painted surfaces. Brake fluid may seriously damage paint. Wipe it off immediately and wash with water if it gets on a painted surface.**
- **Turn the ignition switch OFF and disconnect the ABS actuator and electric unit (control unit) connector or the battery negative terminal before draining.**

1. Connect a vinyl tube to the bleed valve.
2. Depress the brake pedal and loosen the bleeder valve to gradually discharge brake fluid.

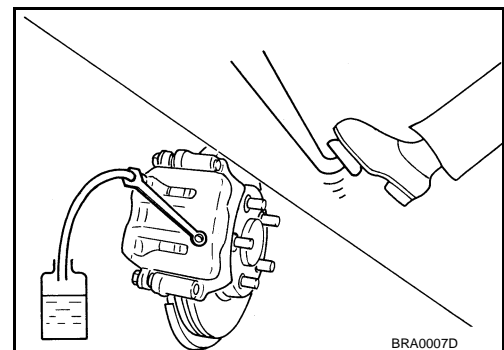

Refilling

INFOID:000000007543248

CAUTION:

Turn the ignition switch OFF and disconnect the ABS actuator and electric unit (control unit) connector or the battery negative terminal before refilling.

1. Check that there is no foreign material in the sub tank, and refill with new brake fluid.

CAUTION:

Never reuse drained brake fluid.

BRAKE FLUID

< PERIODIC MAINTENANCE >

2. Loosen the bleeder valve, slowly depress the brake pedal to the full stroke, and then release the pedal. Repeat this operation at intervals of 2 or 3 seconds until all brake fluid is discharged. Then close the bleeder valve with the brake pedal depressed. Repeat the same work on each wheel.
3. Perform the air bleeding. Refer to [BR-12. "Bleeding Brake System"](#).

Bleeding Brake System

INFOID:000000007543249

CAUTION:

- Turn the ignition switch OFF and disconnect the ABS actuator and electric unit (control unit) connector or the battery negative terminal before performing the work.
 - Monitor the fluid level in the sub tank during the air bleeding.
 - Always use new brake fluid for refilling. Never reuse the drained brake fluid.
1. Connect a vinyl tube to the bleeder valve of the rear right brake.
 2. Fully depress the brake pedal 4 to 5 times.
 3. Loosen the bleeder valve and bleed air with the brake pedal depressed, and then quickly tighten the bleeder valve.
 4. Repeat steps 2 and 3 until all of the air is out of the brake line.
 5. Tighten the bleeder valve to the specified torque.
 - Front disc brake
 - 1 piston type: refer to [BR-37. "BRAKE CALIPER ASSEMBLY \(1 PISTON TYPE\) : Exploded View"](#).
 - 2 piston type: refer to [BR-41. "BRAKE CALIPER ASSEMBLY \(2 PISTON TYPE\) : Exploded View"](#).
 - Rear disc brake: refer to [BR-47. "BRAKE CALIPER ASSEMBLY : Exploded View"](#).
 6. Perform steps 1 to 5 for the rear right brake → front left brake → rear left brake → and front right brake in order.
 7. Check that the fluid level in the sub tank is within the specified range after air bleeding. Refer to [BR-11. "Inspection"](#).

BRAKE MASTER CYLINDER

< PERIODIC MAINTENANCE >

BRAKE MASTER CYLINDER

Inspection

INFOID:000000007543250

FLUID LEAK

Check for brake fluid leakage from the master cylinder mounting face, reservoir tank mounting face, sub tank mounting face, brake tube connections and hose connections.

A

B

C

D

E

BR

G

H

I

J

K

L

M

N

O

P

BRAKE BOOSTER

< PERIODIC MAINTENANCE >

BRAKE BOOSTER

Inspection

INFOID:000000007543251

OPERATION

Depress the brake pedal several times at 5-second intervals with the engine stopped. Start the engine with the brake pedal fully depressed. Check that the clearance between brake pedal and dash lower panel decreases.

NOTE:

A slight impact with a small click may be felt on the pedal when the brake pedal is fully depressed. This is a normal phenomenon due to the brake system operation.

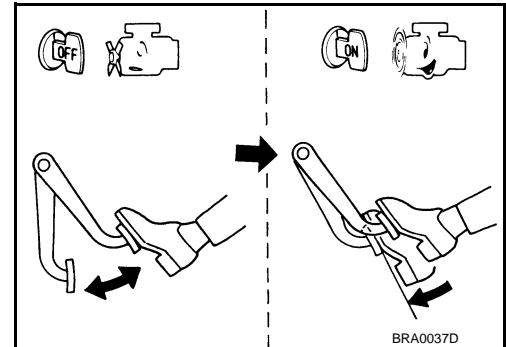

AIR TIGHT

- Idle the engine for 1 minute to apply vacuum to the brake booster, and stop the engine. Then depress the brake pedal several times at 5-second intervals until the accumulated vacuum is released to atmospheric pressure. Check that the clearance between brake pedal and dash lower panel gradually increases (A → B → C) each time the brake pedal is depressed during this operation.

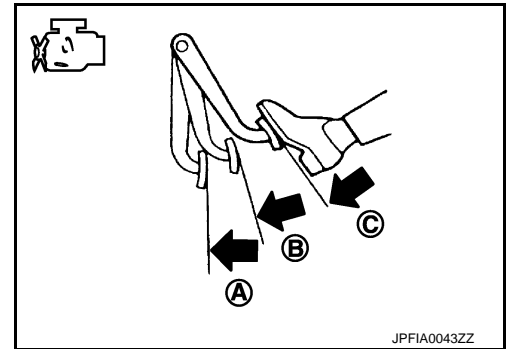

- Depress the brake pedal with the engine running. Then stop the engine while holding down the brake pedal. Check that the brake pedal stroke does not change after holding down the brake pedal for 30 seconds or more.

NOTE:

A slight impact with a small click may be felt on the pedal when the brake pedal is fully depressed. This is a normal phenomenon due to the brake system operation.

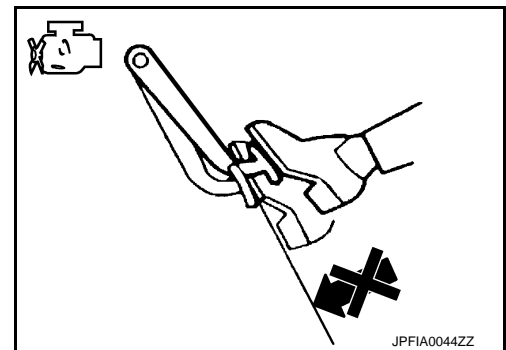

FRONT DISC BRAKE

< PERIODIC MAINTENANCE >

FRONT DISC BRAKE

BRAKE PAD

BRAKE PAD : Inspection and Adjustment

INFOID:000000007543252

INSPECTION

Check brake pad wear thickness from an inspection hole on cylinder body. Check using a scale if necessary.

Limit

Wear thickness

: Refer to [BR-53, "Front Disc Brake"](#).

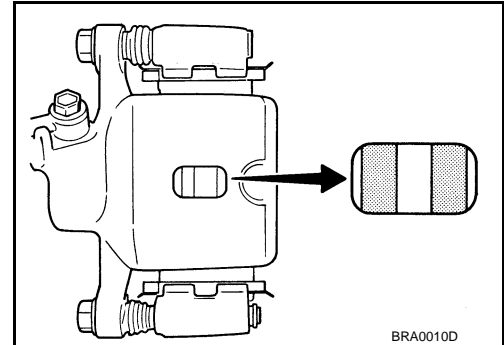

ADJUSTMENT

CAUTION:

- Burnish contact surfaces between pads according to the following procedure after refinishing or replacing pads, or if a soft pedal occurs at very low mileage.
- Be careful of vehicle speed because the brake does not operate firmly/securely until pads and disc rotor are securely fitted.
- Only perform this procedure under safe road and traffic conditions. Use extreme caution.

1. Drive vehicle on straight, flat road.
2. Depress brake pedal with the power to stop vehicle within 3 to 5 seconds until the vehicle stops.
3. Drive without depressing brake for a few minutes to cool the brake.
4. Repeat steps 1 to 3 until pad and disc rotor are securely fitted.

DISC ROTOR

DISC ROTOR : Inspection and Adjustment

INFOID:000000007543253

INSPECTION

Appearance

Check surface of disc rotor for uneven wear, cracks, and serious damage. Replace if there are any abnormal conditions.

Runout

1. Fix the disc rotor to the wheel hub and bearing assembly with wheel nuts (2 points at least).
2. Check the wheel bearing axial end play before the inspection. Refer to [FAX-8, "Inspection"](#) (2WD), [FAX-34, "Inspection"](#) (AWD).
3. Inspect the runout with a dial gauge to measured at 10 mm (0.39 in) inside the disc edge.

Limit

Runout

: Refer to [BR-53, "Front Disc Brake"](#).

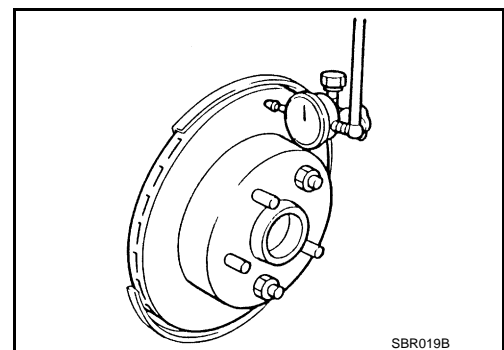

4. Find the installation position with a minimum runout by shifting the disc rotor-to-wheel hub and bearing assembly installation position by one hole at a time if the runout exceeds the limit value.
5. Refinish the disc rotor if the runout is outside the limit even after performing the above operation. [When refinishing, use the Pro-Cut PEM On-Car brake Lathe (Tool No. 38-PFM90.5) or equivalent.]

CAUTION:

FRONT DISC BRAKE

< PERIODIC MAINTENANCE >

- Check in advance that the thickness of the disc rotor is wear thickness + 0.3 mm (0.012 in) or more.
- If the thickness is less than wear thickness + 0.3 mm (0.012 in), replace the disc rotor.

Limit

Wear thickness : Refer to [BR-53, "Front Disc Brake"](#).

Thickness

Check the thickness of the disc rotor using a micrometer. Replace the disc rotor if the thickness is below the wear limit.

Limit

Wear thickness : Refer to [BR-53, "Front Disc Brake"](#).

Thickness variation : Refer to [BR-53, "Front Disc Brake"](#).

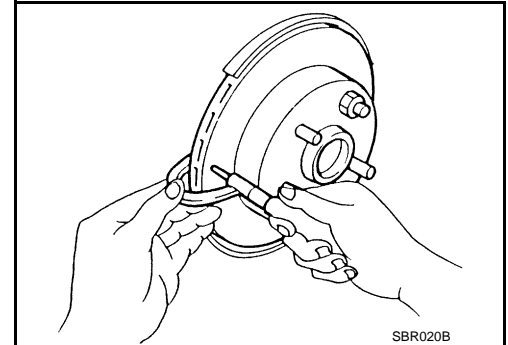

ADJUSTMENT

CAUTION:

- Burnish contact surfaces between pads according to the following procedure after refinishing or replacing pads, or if a soft pedal occurs at very low mileage.
 - Be careful of vehicle speed because the brake does not operate firmly/securely until pads and disc rotor are securely fitted.
 - Only perform this procedure under safe road and traffic conditions. Use extreme caution.
1. Drive vehicle on straight, flat road.
 2. Depress brake pedal with the power to stop vehicle within 3 to 5 seconds until the vehicle stops.
 3. Drive without depressing brake for a few minutes to cool the brake.
 4. Repeat steps 1 to 3 until pad and disc rotor are securely fitted.

REAR DISC BRAKE

< PERIODIC MAINTENANCE >

REAR DISC BRAKE

BRAKE PAD

BRAKE PAD : Inspection and Adjustment

INFOID:000000007543254

INSPECTION

Check brake pad wear thickness from an inspection hole on cylinder body. Check using a scale if necessary.

Limit

Wear thickness

: Refer to [BR-53, "Rear Disc Brake"](#).

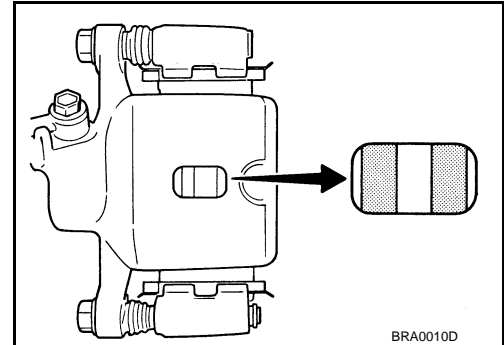

ADJUSTMENT

CAUTION:

- Burnish contact surfaces between pads according to the following procedure after refinishing or replacing pads, or if a soft pedal occurs at very low mileage.
- Be careful of vehicle speed because the brake does not operate firmly/securely until pads and disc rotor are securely fitted.
- Only perform this procedure under safe road and traffic conditions. Use extreme caution.

1. Drive vehicle on straight, flat road.
2. Depress brake pedal with the power to stop vehicle within 3 to 5 seconds until the vehicle stops.
3. Drive without depressing brake for a few minutes to cool the brake.
4. Repeat steps 1 to 3 until pad and disc rotor are securely fitted.

DISC ROTOR

DISC ROTOR : Inspection and Adjustment

INFOID:000000007543255

INSPECTION

Appearance

Check surface of disc rotor for uneven wear, cracks, and serious damage. Replace if there are any abnormal conditions.

Runout

1. Fix the disc rotor to the wheel hub and bearing assembly with wheel nuts (2 points at least).
2. Check the wheel bearing axial end play before the inspection. Refer to [RAX-4, "Inspection"](#) (2WD), [RAX-11, "Inspection"](#) (AWD).
3. Inspect the runout with a dial gauge to measured at 10 mm (0.39 in) inside the disc edge.

Limit

Runout

: Refer to [BR-53, "Rear Disc Brake"](#).

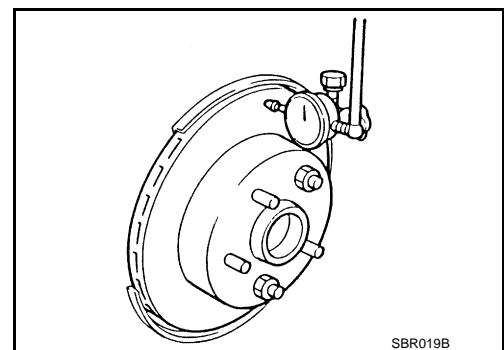

4. Find the installation position with a minimum runout by shifting the disc rotor-to-wheel hub and bearing assembly installation position by one hole at a time if the runout exceeds the limit value.
5. Refinish the disc rotor if the runout is outside the limit even after performing the above operation. [When refinishing, use the Pro-Cut PEM On-Car brake Lathe (Tool No. 38-PFM90.5) or equivalent.]

CAUTION:

REAR DISC BRAKE

< PERIODIC MAINTENANCE >

- Check in advance that the thickness of the disc rotor is wear thickness + 0.3 mm (0.012 in) or more.
- If the thickness is less than wear thickness + 0.3 mm (0.012 in), replace the disc rotor.

Limit

Wear thickness : Refer to [BR-53, "Rear Disc Brake"](#).

Thickness

Check the thickness of the disc rotor using a micrometer. Replace the disc rotor if the thickness is below the wear limit.

Limit

Wear thickness : Refer to [BR-53, "Rear Disc Brake"](#).

Thickness variation : Refer to [BR-53, "Rear Disc Brake"](#).

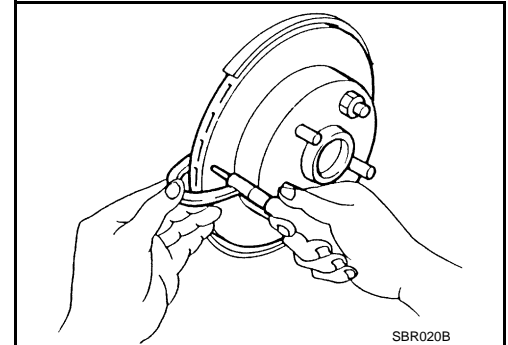

ADJUSTMENT

CAUTION:

- Burnish contact surfaces between pads according to the following procedure after refinishing or replacing pads, or if a soft pedal occurs at very low mileage.
 - Be careful of vehicle speed because the brake does not operate firmly/securely until pads and disc rotor are securely fitted.
 - Only perform this procedure under safe road and traffic conditions. Use extreme caution.
1. Drive vehicle on straight, flat road.
 2. Depress brake pedal with the power to stop vehicle within 3 to 5 seconds until the vehicle stops.
 3. Drive without depressing brake for a few minutes to cool the brake.
 4. Repeat steps 1 to 3 until pad and disc rotor are securely fitted.

BRAKE PEDAL

< REMOVAL AND INSTALLATION >

REMOVAL AND INSTALLATION

BRAKE PEDAL

Exploded View

INFOID:000000007543256

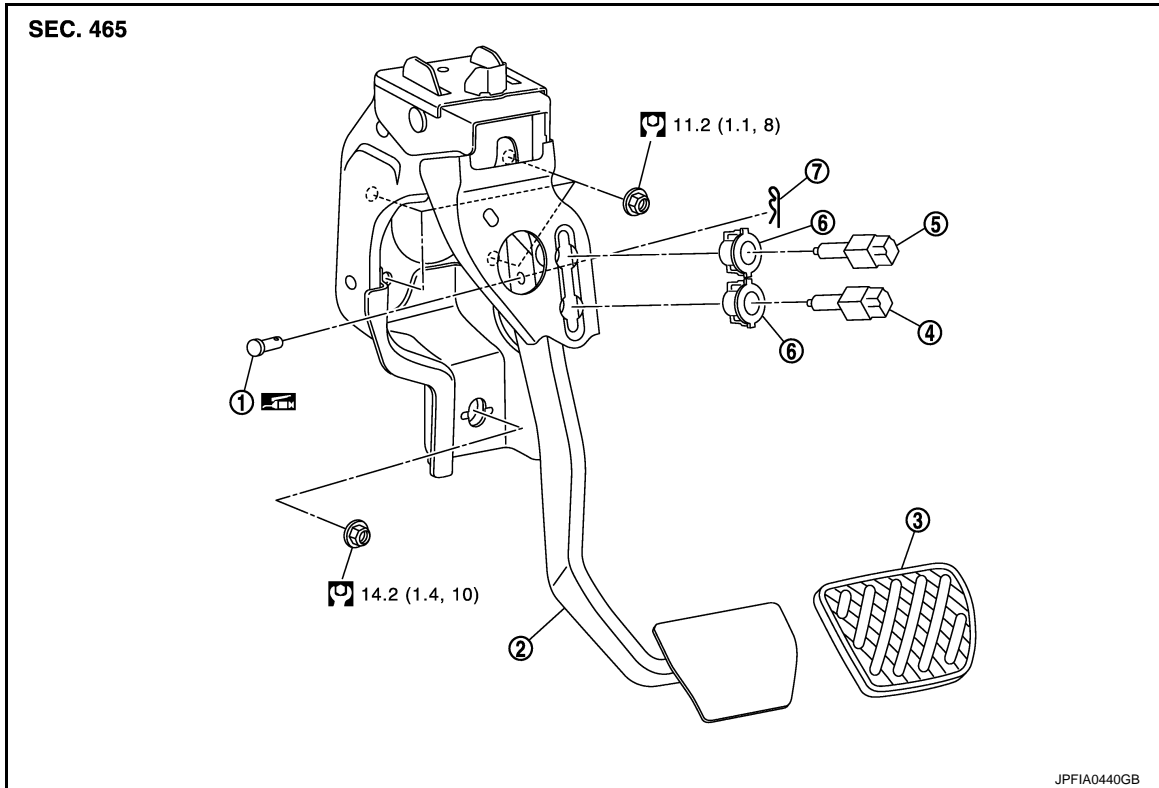

- | | | |
|----------------------|-------------------------|--------------------|
| 1. Clevis pin | 2. Brake pedal assembly | 3. Brake pedal pad |
| 4. ASCD brake switch | 5. Stop lamp switch | 6. Clip |
| 7. Snap pin | | |

: Apply multi-purpose grease.

Refer to [GI-4, "Components"](#) for symbols not described on the above.

Removal and Installation

INFOID:000000007543257

REMOVAL

1. Remove instrument lower panel LH. Refer to [IP-12, "Exploded View"](#).
2. Remove knee protector.
 - With heated steering wheel (without electric motor): Refer to [ST-35, "WITHOUT ELECTRIC MOTOR : Removal and Installation"](#).
 - With heated steering wheel (with electric motor): Refer to [ST-38, "WITH ELECTRIC MOTOR : Removal and Installation"](#).
 - Without heated steering wheel: Refer to [ST-79, "Removal and Installation"](#).
3. Disconnect the stop lamp switch and ASCD brake switch harness connectors.
4. Remove snap pin and clevis pin from clevis of brake booster.
5. Remove the brake pedal assembly.

CAUTION:

Hold the brake booster and master cylinder so as not to drop out or contact them to other parts.

INSTALLATION

Note the following, and install the reverse order of removal.

BRAKE PEDAL

< REMOVAL AND INSTALLATION >

- Apply the multi-purpose grease to the clevis pin and the mating faces. (Not necessary if grease has been already applied.)

NOTE:

The clevis pin may be inserted in either direction.

Inspection and Adjustment

INFOID:000000007543258

INSPECTION AFTER REMOVAL

- Check the following items and replace the brake pedal assembly if necessary.
 - Check the brake pedal upper rivet (made by aluminum) (A) for deformation.
 - Check the brake pedal for bend, damage, and cracks on the welded parts.
 - Check the lapping length (X) of sub-bracket (B) and slide plate (C).

Standard

X : 5.0 mm (0.197 in) or more

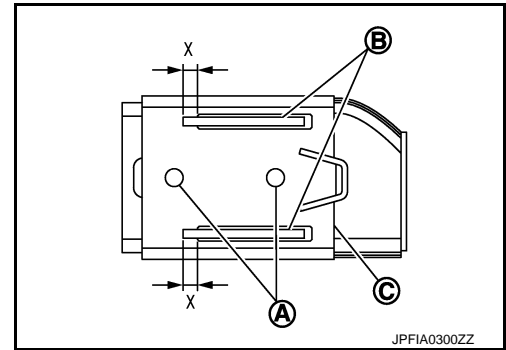

- Check clevis pin and plastic stopper (A) for damage and deformation. If any damage is found, replace clevis pin.

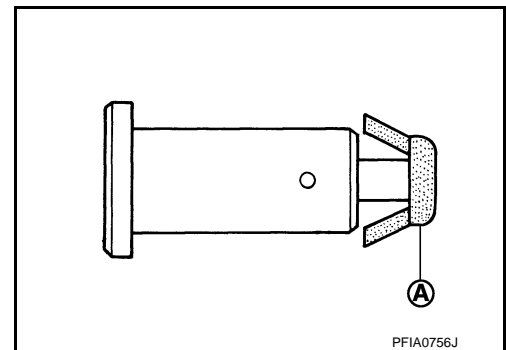

ADJUSTMENT AFTER INSTALLATION

Perform the brake pedal adjustment after installing the brake pedal assembly. Refer to [BR-8. "Inspection and Adjustment"](#).

BRAKE PIPING

< REMOVAL AND INSTALLATION >

BRAKE PIPING FRONT

FRONT : Exploded View

INFOID:000000007543259

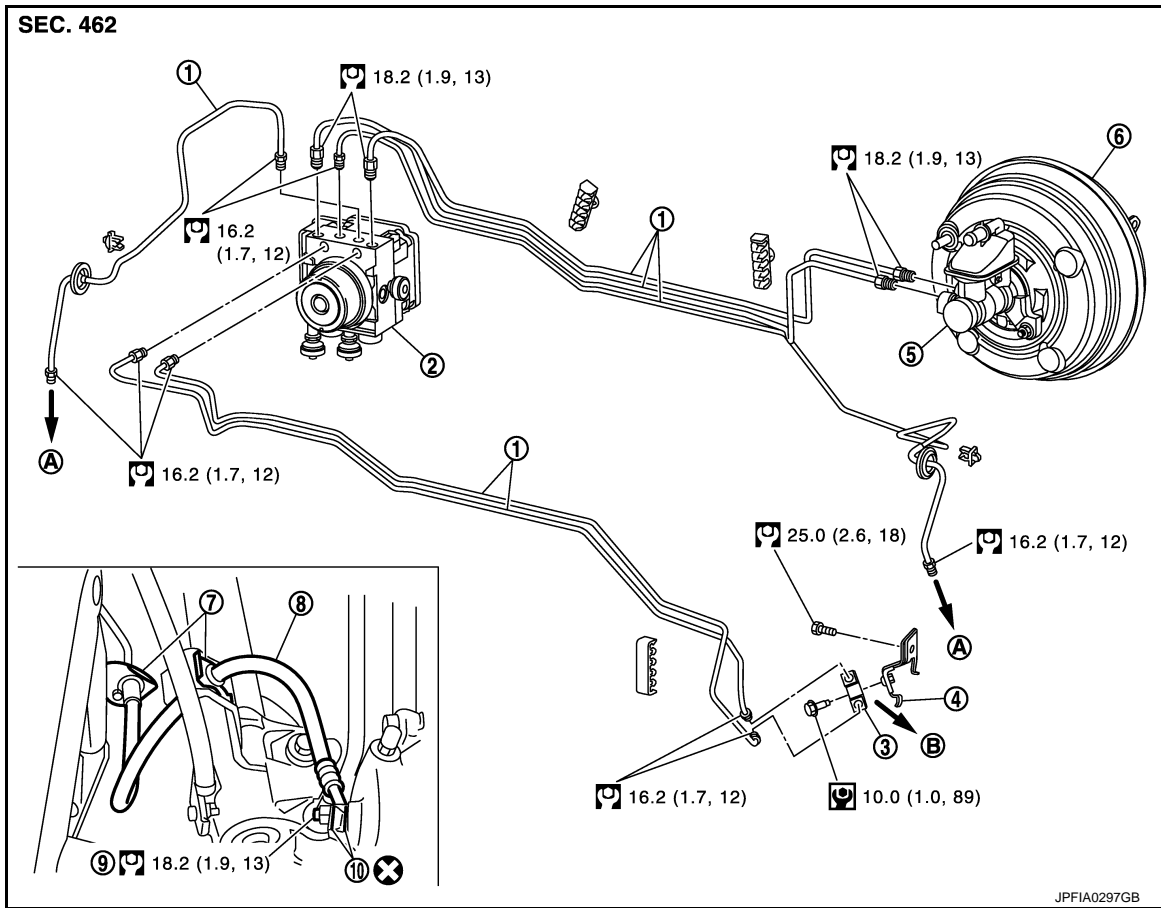

- | | | |
|------------------------|--|------------------|
| 1. Brake tube | 2. ABS actuator and electric unit (control unit) | 3. Connector |
| 4. Connector bracket | 5. Master cylinder assembly | 6. Brake booster |
| 7. Lock plate | 8. Brake hose | 9. Union bolt |
| 10. Copper washer | | |
| A. To front brake hose | B. To rear brake tube | |

Refer to [GI-4, "Components"](#) for symbols in the figure.

A
B
C
D
E
BR
G
H
I
J
K
L
M
N
O
P

BRAKE PIPING

< REMOVAL AND INSTALLATION >

FRONT : Hydraulic Piping

INFOID:000000007543260

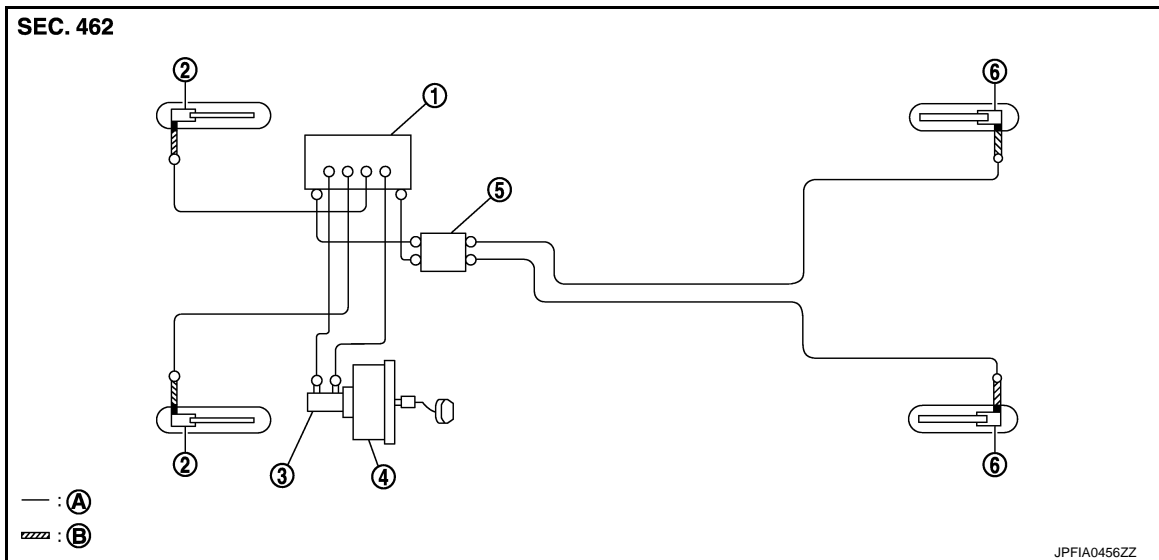

- | | | |
|--|---------------------|-----------------------------|
| 1. ABS actuator and electric unit (control unit) | 2. Front disc brake | 3. Master cylinder assembly |
| 4. Brake booster | 5. Connector | 6. Rear disc brake |
| A. Brake tube | B. Brake hose | |

○: Flare nut

■: Union bolt

FRONT : Removal and Installation

INFOID:000000007543261

REMOVAL

CAUTION:

Never spill or splash brake fluid on painted surfaces. Brake fluid may seriously damage paint. Wipe it off immediately and wash with water if it gets on a painted surface.

1. Remove tires with power tool.
2. Drain brake fluid. Refer to [BR-11, "Draining"](#).
3. Loosen the flare nut with a flare nut wrench and separate the brake tube from the hose.

CAUTION:

- Never scratch the flare nut and the brake tube.
- Never bend sharply, twist or strongly pull out the brake hoses and tubes.
- Cover open end of brake tubes and hoses when disconnecting to prevent entrance of dirt.

4. Remove the union bolt and copper washers, and remove the brake hose from the brake caliper assembly.
5. Remove the lock plate and remove the brake hose.

INSTALLATION

CAUTION:

Never spill or splash brake fluid on painted surfaces. Brake fluid may seriously damage paint. Wipe it off immediately and wash with water if it gets on a painted surface.

1. Assemble the union bolt and the copper washers to the brake hose.

CAUTION:

Never reuse the copper washer.

BRAKE PIPING

< REMOVAL AND INSTALLATION >

- Align the brake hose pin to the projection (A) of the brake caliper assembly and tighten the union bolt (1) to the specified torque.
- Install the brake tube to the brake hose, temporarily tighten the flare nut by hand until it does not rotate further, and fix the brake hose to the bracket with the lock plate.

CAUTION:

Check that all brake hoses and tubes are not twisted and bent.

- Tighten the flare nut to the specified torque with a crowfoot and torque wrench.

CAUTION:

Never scratch the flare nut and the brake tube.

- Refill with new brake fluid and perform the air bleeding. Refer to [BR-12. "Bleeding Brake System"](#).

CAUTION:

Never reuse drained brake fluid.

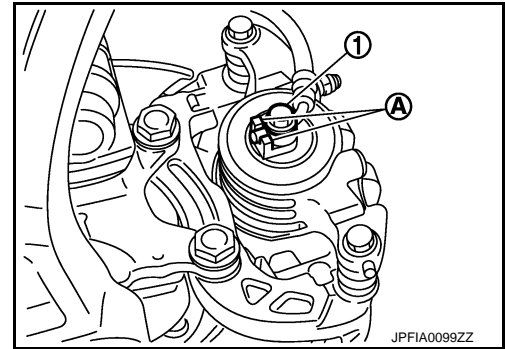

FRONT : Inspection

INFOID:000000007543262

INSPECTION AFTER INSTALLATION

- Check the brake hoses and tubes for the following: no scratches; no twist and deformation; no interference with other components when steering the steering wheel; no looseness at connections.
- Depress the brake pedal with a force of 785 N (80 kg, 176 lb) and hold down the pedal for approximately 5 seconds with the engine running. Check for any fluid leakage.

CAUTION:

Retighten the applicable connection to the specified torque and repair any abnormal (damaged, worn or deformed) part if any brake fluid leakage is present.

REAR

REAR : Exploded View

INFOID:000000007543263

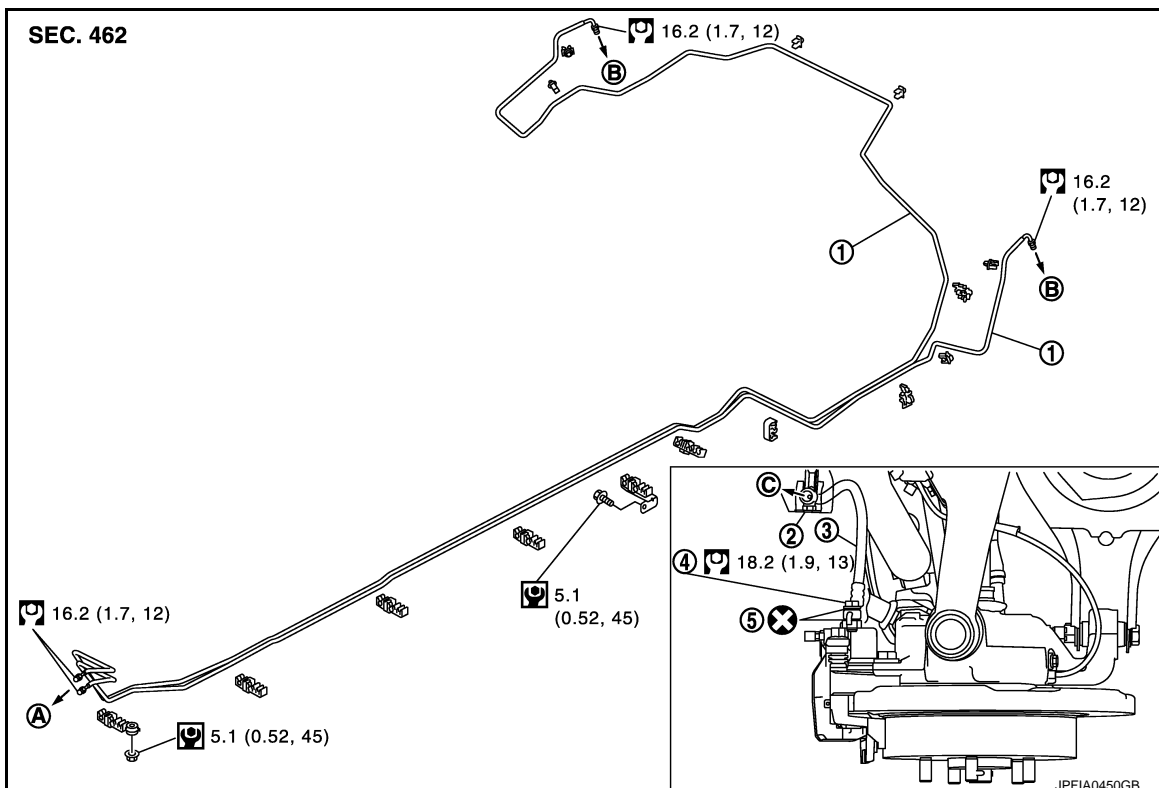

BRAKE PIPING

< REMOVAL AND INSTALLATION >

- | | | |
|-----------------|-----------------------|------------------|
| 1. Brake tube | 2. Lock plate | 3. Brake hose |
| 4. Union bolt | 5. Copper washer | |
| A. To connector | B. To rear brake hose | C. To brake tube |

Refer to [GI-4, "Components"](#) for symbols in the figure.

REAR : Hydraulic Piping

INFOID:000000007543264

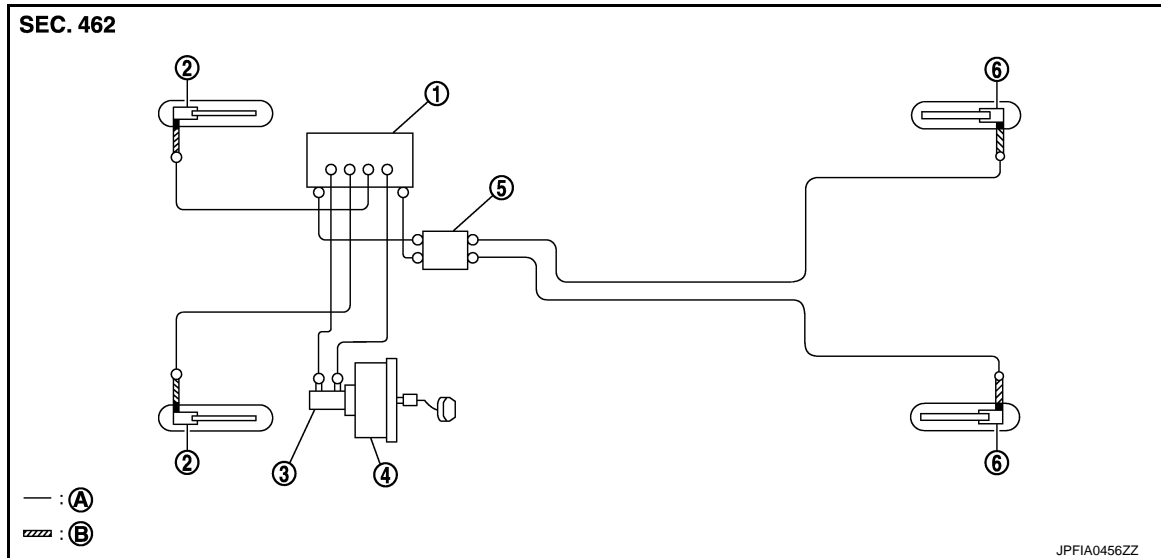

- | | | |
|--|---------------------|-----------------------------|
| 1. ABS actuator and electric unit (control unit) | 2. Front disc brake | 3. Master cylinder assembly |
| 4. Brake booster | 5. Connector | 6. Rear disc brake |
| A. Brake tube | B. Brake hose | |

○: Flare nut

■: Union bolt

REAR : Removal and Installation

INFOID:000000007543265

REMOVAL

CAUTION:

Never spill or splash brake fluid on painted surfaces. Brake fluid may seriously damage paint. Wipe it off immediately and wash with water if it gets on a painted surface.

1. Remove tires with power tool.
2. Drain brake fluid. Refer to [BR-11, "Draining"](#).
3. Loosen the flare nut with a flare nut wrench and separate the brake tube from the hose.

CAUTION:

- **Never scratch the flare nut and the brake tube.**
- **Never sharply bend, twist or strongly pull the brake hoses and tubes.**
- **Cover the open end of brake tubes and hoses when disconnecting to prevent entrance of dirt.**

4. Remove the union bolt and copper washers, and remove the brake hose from the brake caliper assembly.
5. Remove the lock plate and remove the brake hose from the vehicle.

INSTALLATION

CAUTION:

Never spill or splash brake fluid on painted surfaces. Brake fluid may seriously damage paint. Wipe it off immediately and wash with water if it gets on a painted surface.

1. Assemble the union bolt and the copper washers to the brake hose.

CAUTION:

Never reuse copper washer.

BRAKE PIPING

< REMOVAL AND INSTALLATION >

2. Install the brake hose L-pin by aligning it with the brake caliper assembly positioning hole, and tighten the union bolt (1) to the specified torque.
3. Connect the hose to the brake tube, temporarily tighten the flare nut by hand until it does not rotate further, and fix the brake hose to the bracket with the lock plate.

CAUTION:

Check that the brake hoses and tubes are not twisted and bent.

4. Tighten the flare nut to the specified torque with a crowfoot and torque wrench.

CAUTION:

Never scratch the flare nut and the brake tube.

5. Refill with new brake fluid and perform the air bleeding. Refer to [BR-12, "Bleeding Brake System"](#).

CAUTION:

Never reuse drained brake fluid.

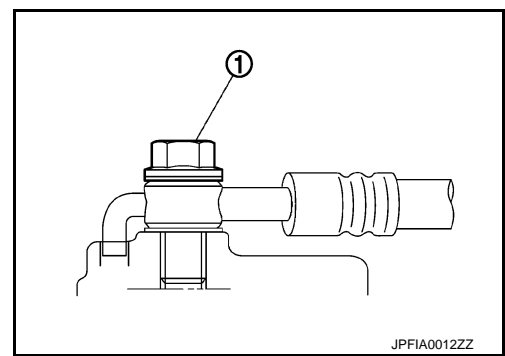

REAR : Inspection

INFOID:000000007543266

BR

INSPECTION AFTER INSTALLATION

1. Check the brake hoses and tubes for the following: no scratches; no twist and deformation; no interference with other components when steering the steering wheel; no looseness at connections.
2. Depress the brake pedal with a force of 785 N (80 kg, 176 lb) and hold down the pedal for approximately 5 seconds with the engine running. Check for any fluid leakage.

CAUTION:

Retighten the applicable connection to the specified torque and repair any abnormal (damaged, worn or deformed) part if any brake fluid leakage is present.

G

H

I

J

K

L

M

N

O

P

BRAKE MASTER CYLINDER

< REMOVAL AND INSTALLATION >

BRAKE MASTER CYLINDER

Exploded View

INFOID:000000007543267

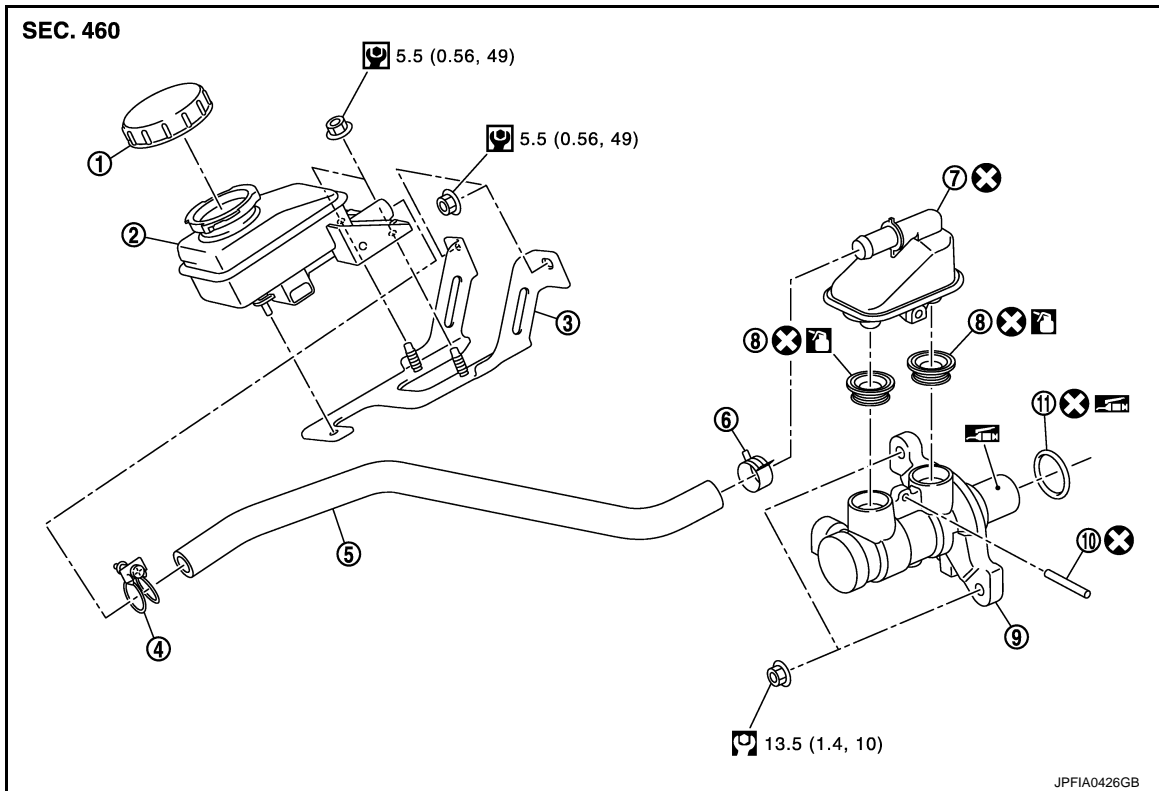

- | | | |
|-------------------|-------------|---------------------|
| 1. Sub tank cap | 2. Sub tank | 3. Sub tank bracket |
| 4. Clamp | 5. Hose | 6. Clamp |
| 7. Reservoir tank | 8. Grommet | 9. Cylinder body |
| 10. Pin | 11. O-ring | |

: Apply PBC (Poly Butyl Cuprysil) grease or silicone-based grease.

: Apply brake fluid.

Refer to [GI-4, "Components"](#) for symbols not described on the above.

Removal and Installation

INFOID:000000007543268

REMOVAL

CAUTION:

Never spill or splash brake fluid on painted surfaces. Brake fluid may seriously damage paint. Wipe it off immediately and wash with water if it gets on a painted surface.

1. Drain brake fluid. Refer to [BR-11, "Draining"](#).
2. Separate the brake fluid level switch harness connector.
3. Remove sub tank and hose.
4. Remove cowl top cover. Refer to [EXT-20, "Exploded View"](#).
5. Remove front wiper drive assembly. Refer to [WW-111, "Exploded View"](#).
6. Remove extension cowl top. Refer to [EXT-20, "Exploded View"](#).
7. Remove air duct assembly and air cleaner case. Refer to [EM-31, "Exploded View"](#).
8. Separate the brake tubes from the master cylinder assembly with a flare nut wrench.

CAUTION:

Never scratch the flare nut and the brake tube.

9. Remove the master cylinder assembly.

BRAKE MASTER CYLINDER

< REMOVAL AND INSTALLATION >

CAUTION:

- Depress the brake pedal several times to release the vacuum pressure from the brake booster. Then remove the master cylinder assembly.
- Never depress the brake pedal after the master cylinder assembly is removed.
- The piston of the master cylinder assembly is exposed. Never damage it when removing the master cylinder.
- The piston may drop off when pulled out strongly. Never hold the piston. Hold the cylinder body when handling the master cylinder assembly.

INSTALLATION

CAUTION:

Never spill or splash brake fluid on painted surfaces. Brake fluid may seriously damage paint. Wipe it off immediately and wash with water if it gets on a painted surface.

Note the following, and install the reverse order of removal.

- Never depress the brake pedal after the master cylinder assembly is removed.
- Apply PBC (Poly Butyl Cuprysil) silicone-based grease to the brake booster [see (A) in the figure] when installing the master cylinder assembly to the brake booster.
- The piston of the master cylinder assembly is exposed. Never damage it when handling the master cylinder and check that no dirt and dust are present on the piston before installation. Clean it with new brake fluid if necessary.
- The piston may drop off when pulled strongly. Never hold the piston. Hold the cylinder body when handling the master cylinder assembly.
- Temporarily tighten the brake tube flare nut to the master cylinder assembly by hand. Then tighten it to the specified torque with a crowfoot and torque wrench. Refer to [BR-21, "FRONT : Exploded View"](#).

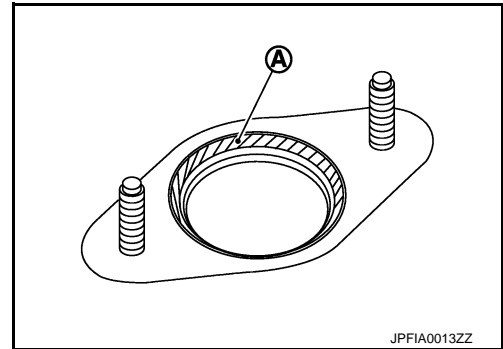

CAUTION:

Never scratch the flare nut and the brake tube.

- After installation, perform the air bleeding. Refer to [BR-12, "Bleeding Brake System"](#).

CAUTION:

Never reuse drained brake fluid.

Disassembly and Assembly

INFOID:000000007543269

DISASSEMBLY

CAUTION:

- Never disassemble the cylinder body.
- Remove the reservoir tank if necessary.

1. Fix the master cylinder assembly to a vise.

CAUTION:

Always set copper plates or cloth between vise when fixing the cylinder body to a vise. Never overtighten the vise.

2. Remove the reservoir tank mounting pin with a pin punch.
3. Remove the reservoir tank and grommet from the cylinder body.

CAUTION:

Never drop the removed parts. The parts must not be reused if they are dropped.

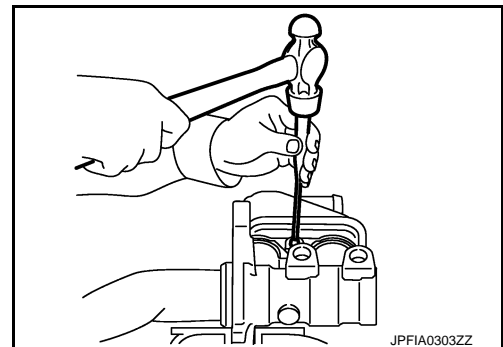

ASSEMBLY

1. Apply new brake fluid to the grommet and install it to the cylinder body.

CAUTION:

- Never use mineral oil such as gasoline or light oil.
- Never reuse the grommets.

BRAKE MASTER CYLINDER

< REMOVAL AND INSTALLATION >

2. Install the reservoir tank to the cylinder body.

CAUTION:

- Never drop the parts when installing. The parts must not be reused if they are dropped.
- Never reuse reservoir tank.

3. Fix the cylinder body to a vise.

CAUTION:

- Place the reservoir tank with the chamfered pin hole (←) facing up.
- Always set copper plates or cloth between vise when fixing the cylinder body to a vise. Never overtighten the vise.

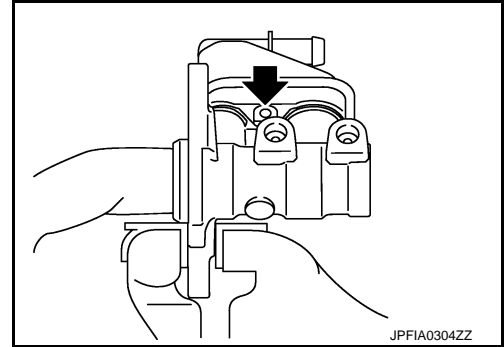

4. Tilt the reservoir tank so that a mounting pin can be inserted. Insert a mounting pin. Return the reservoir tank to the horizontal position. Insert another mounting pin into the pin hole on the opposite side in the same manner after the mounting pin passes through the cylinder body pin hole.

CAUTION:

- Never reuse the mounting pin.

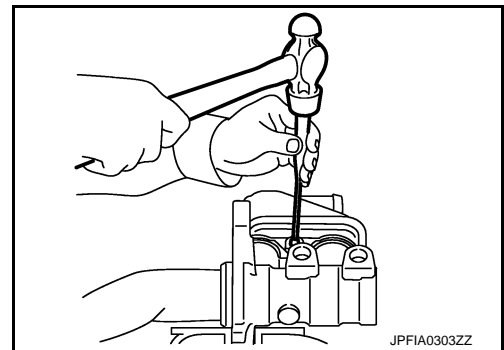

Inspection

INFOID:000000007543270

INSPECTION AFTER INSTALLATION

Fluid Leak

Check for brake fluid leakage from the cylinder body-to-brake booster mounting face, reservoir tank mounting face, brake tube connections and hose connections.

BRAKE BOOSTER

< REMOVAL AND INSTALLATION >

BRAKE BOOSTER

Exploded View

INFOID:000000007543271

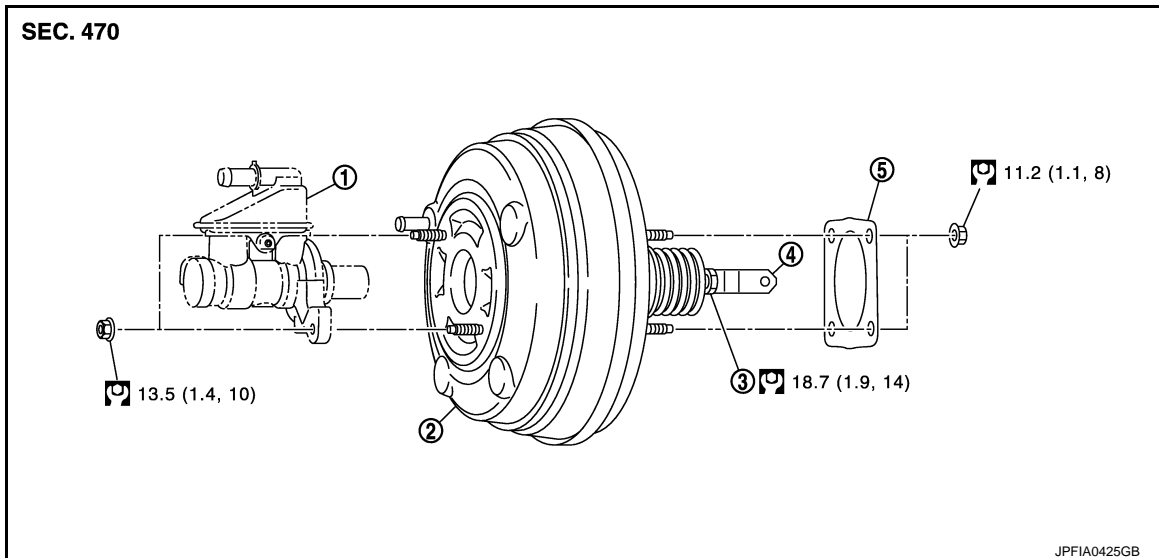

- | | | |
|-----------------------------|------------------|-------------|
| 1. Master cylinder assembly | 2. Brake booster | 3. Lock nut |
| 4. Clevis | 5. Gasket | |

Refer to [GI-4, "Components"](#) for symbols in the figure.

Removal and installation

INFOID:000000007543272

REMOVAL

- Remove brake master cylinder assembly. Refer to [BR-26, "Exploded View"](#).
CAUTION:
 - Depress the brake pedal several times to release the vacuum pressure from the brake booster. Then remove the master cylinder assembly.
 - Never depress the brake pedal after the master cylinder assembly is removed.
 - The piston of the master cylinder assembly is exposed. Never damage it when removing the master cylinder.
 - The piston may drop off when pulled out strongly. Never hold the piston. Hold the cylinder body when handling the master cylinder assembly.
- Remove vacuum hose from brake booster. Refer to [BR-32, "Exploded View"](#).
- Remove snap pin (1) and clevis pin (2) from inside vehicle.
- Remove nuts on brake booster and brake pedal assembly.
CAUTION:
Hold the brake booster so as to avoid dropping out.
- Remove brake booster from dash panel in engine room side.
CAUTION:
Never deform or bend the brake tubes.

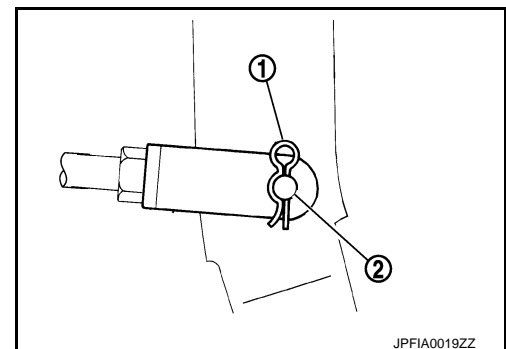

INSTALLATION

Note the following, and installation is the reverse order of removal.

- Be careful not to damage brake booster stud bolt threads. If brake booster is tilted during installation, the dash panel may damage the threads.
- Never deform or bend the brake tubes when installing the brake booster.
- Always use a new gasket between the brake booster.

BRAKE BOOSTER

< REMOVAL AND INSTALLATION >

- Replace the clevis pin if it is damaged. Refer to [BR-20, "Inspection and Adjustment"](#).
- After installation, perform the air bleeding. Refer to [BR-12, "Bleeding Brake System"](#).

CAUTION:

Never reuse drained brake fluid.

Inspection and Adjustment

INFOID:000000007543273

INSPECTION AFTER REMOVAL

Air Tight

CAUTION:

Check the air tight condition when the master cylinder and the brake booster is installed.

1. With a handy vacuum pump, apply vacuum pressure of -66.7 kPa (-500 mmHg, -19.70 inHg) to the brake booster.
2. If the air tight condition cannot be maintained, perform the following operation.
 - a. Check the no dirt and dust are present on the brake booster and brake master cylinder mating faces. Clean it if necessary.
 - b. Check O-ring on the master cylinder. If anything is found, replace the O-ring.
 - c. Check the air tight condition again. If the condition still cannot be maintained, replace the brake booster.

Input Rod Length Inspection

1. Loosen the lock nut (1) and adjust the input rod (2) to the specified length (B).

Standard

B

: Refer to [BR-53, "Brake Booster"](#).

2. Tighten the lock nut to the specified torque.

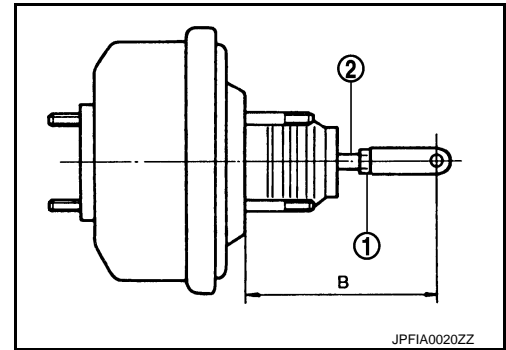

INSPECTION AFTER INSTALLATION

Operation

Depress the brake pedal several times at 5-second intervals with the engine stopped. Start the engine with the brake pedal fully depressed. Check that the clearance between brake pedal and dash lower pane decreases.

NOTE:

A slight impact with a small click may be felt on the pedal when the brake pedal is fully depressed. This is a normal phenomenon due to the brake system operation.

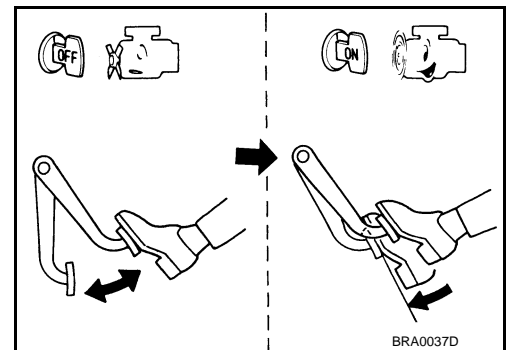

Air Tight

BRAKE BOOSTER

< REMOVAL AND INSTALLATION >

- Idle the engine for 1 minute to apply vacuum to the brake booster, and stop the engine. Then depress the brake pedal several times at 5-second intervals until the accumulated vacuum is released to atmospheric pressure. Check that the clearance between brake pedal and dash lower panel gradually increases (A → B → C) each time the brake pedal is depressed during this operation.

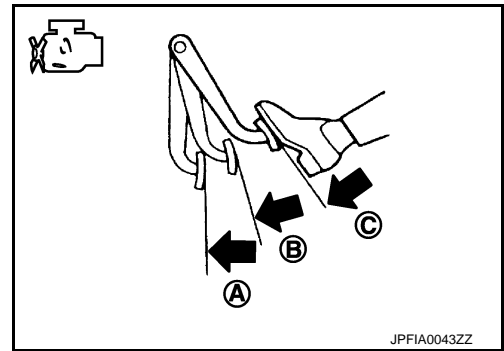

- Depress the brake pedal with the engine running. Then stop the engine while holding down the brake pedal. Check that the brake pedal stroke does not change after holding down the brake pedal for 30 seconds or more.

NOTE:

A slight impact with a small click may be felt on the pedal when the brake pedal is fully depressed. This is a normal phenomenon due to the brake system operation.

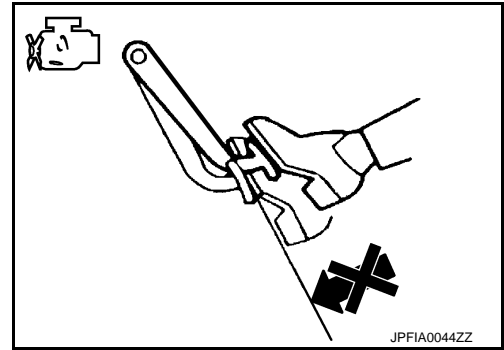

ADJUSTMENT AFTER INSTALLATION

Perform the brake pedal adjustment after installing the brake pedal assembly. Refer to [BR-8, "Inspection and Adjustment"](#).

A
B
C
D
E
BR
G
H
I
J
K
L
M
N
O
P

VACUUM LINES

< REMOVAL AND INSTALLATION >

VACUUM LINES

Exploded View

INFOID:000000007543274

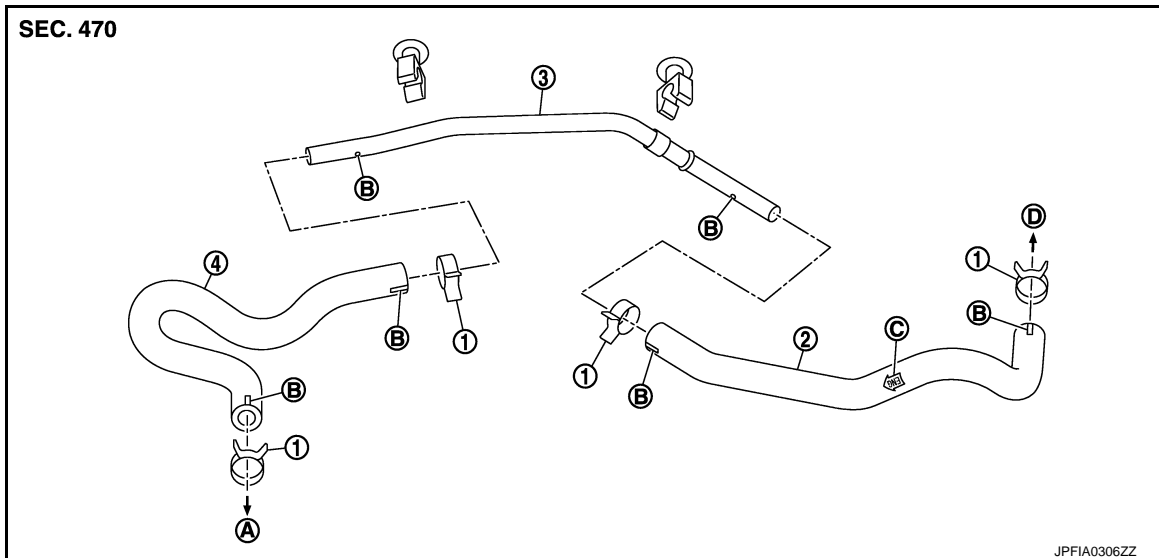

- | | | |
|-----------------------|---------------------------------------|--------------------------------------|
| 1. Clamp | 2. Vacuum hose (built in check valve) | 3. Vacuum tube |
| 4. Vacuum hose | | |
| A. To intake manifold | B. Paint mark | C. Stamp indicating engine direction |
| D. To brake booster | | |

Removal and Installation

INFOID:000000007543275

REMOVAL

Remove the vacuum hose and tube.

INSTALLATION

Note the following, install the vacuum hose and tube.

- Because vacuum hose contains a check valve, it must be installed in the correct position. Refer to the stamp to confirm correct installation. Brake booster will not operate normally if the hose is installed in the wrong direction.
- When installing vacuum hose, insert it until its tip reaches the back-end of length (A) or further as shown in the figure.

Standard

A : 24 mm (0.95 in) or more

- Face the marking side up when assembling of vacuum hose. (Brake booster and intake manifold side)
- Face the marking side vehicle front when assembling of vacuum hose. (Vacuum tube side)

CAUTION:

Never use lubricating oil during assembly.

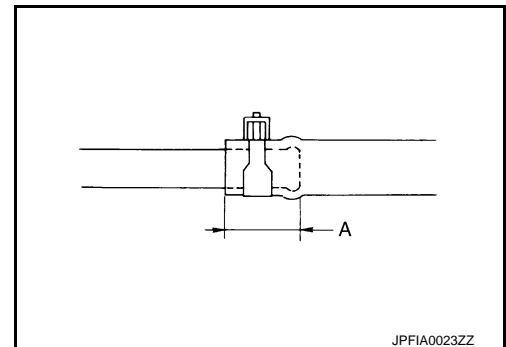

Inspection

INFOID:000000007543276

INSPECTION AFTER REMOVAL

Appearance

Check for correct assembly, damage and deterioration.

Check Valve Airtightness

VACUUM LINES

< REMOVAL AND INSTALLATION >

- Use a handy vacuum pump (A) to check.

When connected to the brake booster side (B)

: Vacuum should decrease within 1.3 kPa (10 mm-Hg, 0.39 inHg) for 15 seconds under a vacuum of –66.7 kPa (–500 mmHg, –19.70 inHg).

When connected to the engine side (C):

: Vacuum should not exist.

- Replace vacuum hose assembly if vacuum hose and check valve are malfunctioning.

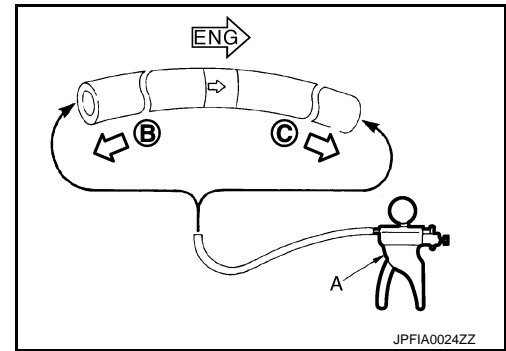

A
B
C
D
E
BR
G
H
I
J
K
L
M
N
O
P

FRONT DISC BRAKE

< REMOVAL AND INSTALLATION >

FRONT DISC BRAKE BRAKE PAD (1 PISTON TYPE)

BRAKE PAD (1 PISTON TYPE) : Exploded View

INFOID:000000007543277

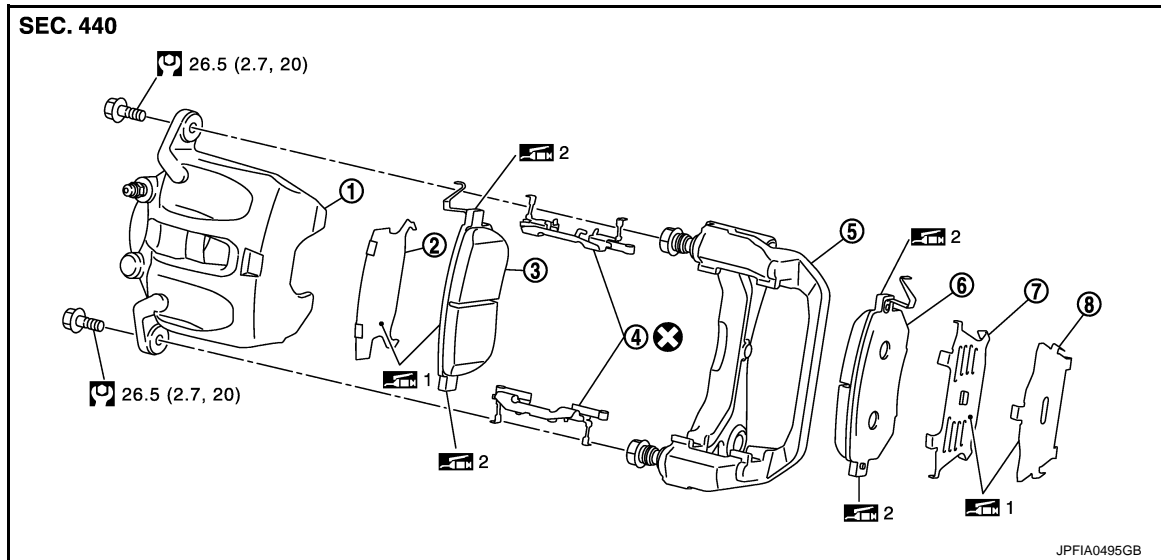

- | | | |
|------------------|---------------------|-------------------------------------|
| 1. Cylinder body | 2. Inner shim | 3. Inner pad (with pad wear sensor) |
| 4. Pad retainer | 5. Torque member | 6. Outer pad |
| 7. Outer shim | 8. Outer shim cover | |

1: Apply PBC (Poly Butyl Cuprysil) grease or silicone-based grease.

2: Apply copper based brake grease.

Refer to [GI-4. "Components"](#) for symbols not described on the above.

BRAKE PAD (1 PISTON TYPE) : Removal and Installation

INFOID:000000007543278

REMOVAL

WARNING:

Since dust covering the front brake has an affect on human body, the dust must be removed with a dust collector. Never splatter the dust with an air blow gun.

CAUTION:

- Never depress the brake pedal while removing the brake pads because the piston may pop out.
- Never spill or splash brake fluid on the disc rotor.

1. Remove tires with power tool.
2. Remove lower sliding pin bolt.
3. Suspend the cylinder body with suitable wire so that the brake hose will not stretch. Then remove the brake pads, shims and shim cover from the torque member.

CAUTION:

- Never reuse the pad retainers when removed the pad retainers from the torque member.
- Never damage the piston boot.
- Never drop the brake pads, shims, and the shim cover.
- Remember each position of the removed brake pads.

INSTALLATION

WARNING:

Since dust covering the front brake has an affect on human body, the dust must be removed with a dust collector. Never splatter the dust with an air blow gun.

CAUTION:

- Never depress the brake pedal while removing the brake pads or the cylinder body because the piston may pop out.

FRONT DISC BRAKE

< REMOVAL AND INSTALLATION >

- **Never spill or splash brake fluid on the disc rotor.**

1. Install the pad retainer to the torque member if the pad retainers has been removed.
CAUTION:
 - **Never reuse the pad retainers.**
 - **Securely assemble the pad retainers so that it will not be lifted up from the torque member.**
 - **Never deform the pad retainers.**
 - **Eliminate double-faced adhesive tape on torque member.**
 - **Remove adhesive's protective liner on pad retainers.**
2. Apply PBC (Poly Butyl Cuprysil) grease or silicone-based grease to the mating faces between the brake pads and pad retainers.
3. Apply copper based brake grease to the mating faces between the brake pads, shims and shim covers, and install them to the brake pad.
CAUTION:
Always replace the shims together with the shim covers when replacing the brake pad.
4. Install the cylinder body and brake pads to the torque member.
CAUTION:
 - **Never damage the piston boot.**
 - **When replacing a pad with new one, check a brake fluid level in the reservoir tank because brake fluid returns to master cylinder reservoir tank when pressing piston in.****NOTE:**
Use a disc brake piston tool to easily press piston.
5. Install the lower sliding pin bolt and tighten it to the specified torque.
6. Depress the brake pedal several times to check that no drag feel is present for the front disc brake. Refer to [BR-35, "BRAKE PAD \(1 PISTON TYPE\) : Inspection"](#).

BRAKE PAD (1 PISTON TYPE) : Inspection

INFOID:000000007543279

INSPECTION AFTER REMOVAL

Replace the shims and the shim cover if rust is excessively attached.

INSPECTION AFTER INSTALLATION

1. Check a drag of front disc brake. If any drag is found, follow the procedure described below.
2. Remove brake pads.
3. Press the piston.
CAUTION:
 - **Never damage the piston boot.**
 - **When replacing a pad with new one, check a brake fluid level in the reservoir tank because brake fluid returns to master cylinder reservoir tank when pressing piston in.****NOTE:**
Use a disc brake piston tool to easily press piston.
4. Install brake pads.
5. Depress the brake pedal several times.
6. Check a drag of front disc brake again. If any drag is found, disassemble the cylinder body. Refer to [BR-39, "BRAKE CALIPER ASSEMBLY \(1 PISTON TYPE\) : Disassembly and Assembly"](#).
7. Burnish contact surfaces after refinishing or replacing pads, or if a soft pedal occurs at very low mileage. Refer to [BR-15, "BRAKE PAD : Inspection and Adjustment"](#).

BRAKE PAD (2 PISTON TYPE)

FRONT DISC BRAKE

< REMOVAL AND INSTALLATION >

BRAKE PAD (2 PISTON TYPE) : Exploded View

INFOID:000000008713759

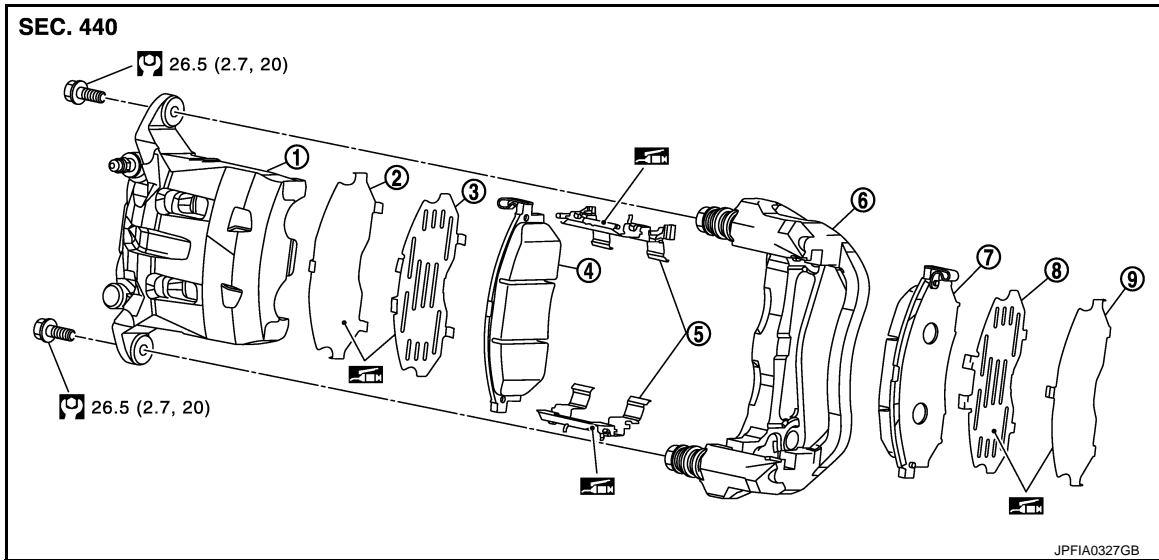

- | | | |
|-------------------------------------|---------------------|---------------------|
| 1. Cylinder body | 2. Inner shim cover | 3. Inner shim |
| 4. Inner pad (with pad wear sensor) | 5. Pad retainer | 6. Torque member |
| 7. Outer pad (with pad wear sensor) | 8. Outer shim | 9. Outer shim cover |

 Apply copper based brake grease.

Refer to [GI-4, "Components"](#) for symbols not described on the above.

BRAKE PAD (2 PISTON TYPE) : Removal and Installation

INFOID:000000008713760

REMOVAL

WARNING:

Since dust covering the front brake has an affect on human body, the dust must be removed with a dust collector. Never splatter the dust with an air blow gun.

CAUTION:

- Never depress the brake pedal while removing the brake pads because the piston may pop out.
- Never spill or splash brake fluid on the disc rotor.

1. Remove tires with power tool.
2. Remove lower sliding pin bolt.
3. Suspend the cylinder body with suitable wire so that the brake hose will not stretch. Then remove the brake pads, shims and shim covers from the torque member.

CAUTION:

- Never reuse the pad retainers > when removed the pad retainers from the torque member.
- Never damage the piston boot.
- Never drop the brake pads, shims, and the shim covers.
- Remember each position of the removed brake pads.

INSTALLATION

WARNING:

Since dust covering the front brake has an affect on human body, the dust must be removed with a dust collector. Never splatter the dust with an air blow gun.

CAUTION:

- Never depress the brake pedal while removing the brake pads or the cylinder body because the piston may pop out.
- Never spill or splash brake fluid on the disc rotor.

1. Apply copper based brake grease to the pad retainers before installing it to the torque member if the pad retainers has been removed.

CAUTION:

FRONT DISC BRAKE

< REMOVAL AND INSTALLATION >

- Securely assemble the pad retainers so that it will not be lifted up from the torque member.
 - Never deform the pad retainers.
- Apply copper based brake grease to the mating faces between the shims and shim covers, and install them to the brake pads.
CAUTION:
Always replace the shims together with the shim covers when replacing the brake pad.
 - Install the brake pads to the torque member.
CAUTION:
Both inner and outer pads have a pad return system on the pad retainer. Install pad return lever (1) securely to pad wear sensor (2).
 - Install the cylinder body to the torque member.
CAUTION:
 - Never damage the piston boot.
 - When replacing a pad with new one, check a brake fluid level in the reservoir tank because brake fluid returns to master cylinder reservoir tank when pressing piston in.**NOTE:**
Use a disc brake piston tool to easily press piston.
 - Install the lower sliding pin bolt and tighten it to the specified torque.
 - Depress the brake pedal several times to check that no drag feel is present for the front disc brake. Refer to [BR-37. "BRAKE PAD \(2 PISTON TYPE\) : Inspection"](#).

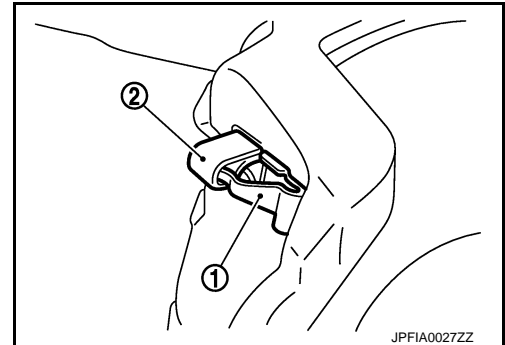

BRAKE PAD (2 PISTON TYPE) : Inspection

INFOID:000000008713761

INSPECTION AFTER REMOVAL

Replace the shims and the shim covers if rust is excessively attached.

INSPECTION AFTER INSTALLATION

- Check a drag of front disc brake. If any drag is found, follow the procedure described below.
- Remove brake pads.
- Press the piston.
CAUTION:
 - Never damage the piston boot.
 - When replacing a pad with new one, check a brake fluid level in the reservoir tank because brake fluid returns to master cylinder reservoir tank when pressing piston in.**NOTE:**
Use a disc brake piston tool to easily press piston.
- Install brake pads.
- Depress the brake pedal several times.
- Check a drag of front disc brake again. If any drag is found, disassemble the cylinder body. Refer to [BR-43. "BRAKE CALIPER ASSEMBLY \(2 PISTON TYPE\) : Disassembly and Assembly"](#).
- Burnish contact surfaces after refinishing or replacing pads, or if a soft pedal occurs at very low mileage. Refer to [BR-15. "BRAKE PAD : Inspection and Adjustment"](#).

BRAKE CALIPER ASSEMBLY (1 PISTON TYPE)

BRAKE CALIPER ASSEMBLY (1 PISTON TYPE) : Exploded View

INFOID:000000007543280

REMOVAL

FRONT DISC BRAKE

< REMOVAL AND INSTALLATION >

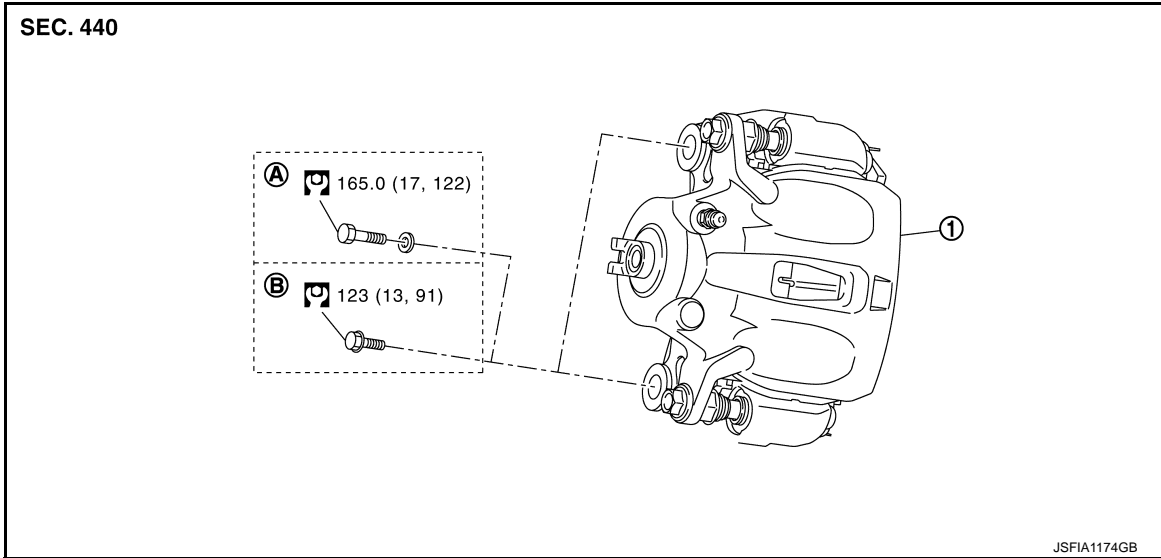

1. Brake caliper assembly
 - A. Hexagon head bolt and washer B. Hexagon flange bolt
- Refer to [GI-4, "Components"](#) for symbols not described on the above.

DISASSEMBLY

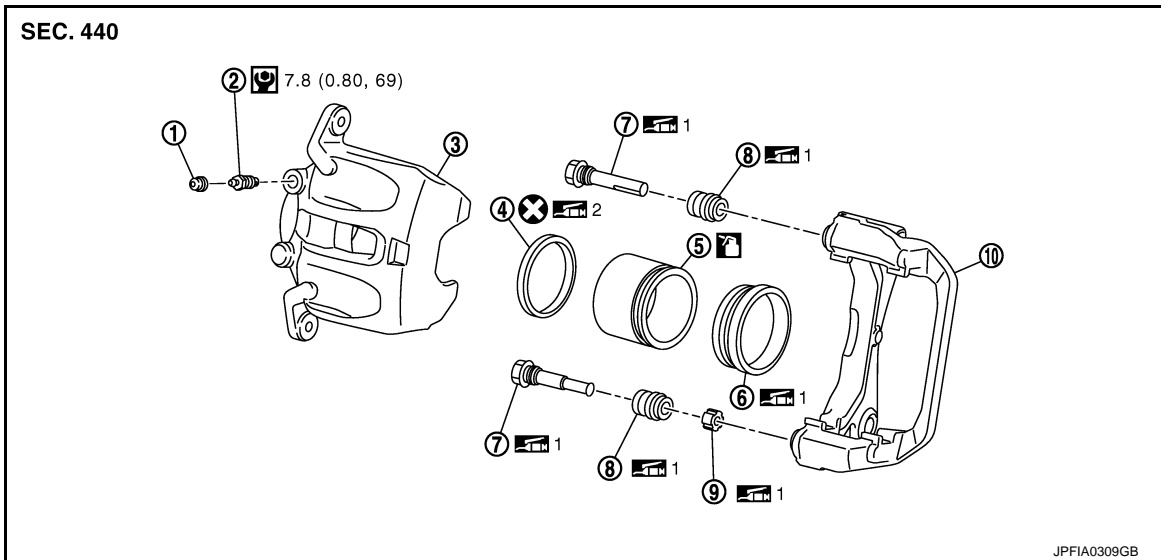

- | | | |
|-------------------|---------------------|------------------|
| 1. Cap | 2. Bleeder valve | 3. Cylinder body |
| 4. Piston seal | 5. Piston | 6. Piston boot |
| 7. Sliding pin | 8. Sliding pin boot | 9. Bushing |
| 10. Torque member | | |

1: Apply rubber grease.

2: Apply polyglycol ether based lubricant.

: Apply brake fluid.

Refer to [GI-4, "Components"](#) for symbols not described on the above.

BRAKE CALIPER ASSEMBLY (1 PISTON TYPE) : Removal and Installation

INFOID:000000007543281

REMOVAL

FRONT DISC BRAKE

< REMOVAL AND INSTALLATION >

WARNING:

Since dust covering the front brake has an affect on human body, the dust must be removed with a dust collector. Never splatter the dust with an air blow gun.

CAUTION:

Never depress the brake pedal. Brake fluid may splash while removing the brake hose.

1. Remove tires with power tool.
2. Fix the disc rotor using wheel nuts.
3. Drain brake fluid. Refer to [BR-11, "Draining"](#).

CAUTION:

Never spill or splash brake fluid on the disc rotor.

4. Remove union bolt and copper washers, and then disconnect brake hose from caliper assembly. Refer to [BR-21, "FRONT : Exploded View"](#).
5. Remove torque member mounting bolts, and remove brake caliper assembly.

CAUTION:

Never drop brake pads and caliper assembly.

6. Remove disc rotor.

CAUTION:

- Put matching marks on the wheel hub and bearing assembly and the disc rotor before removing the disc rotor.
- Never drop disc rotor.

INSTALLATION

WARNING:

Since dust covering the front brake has an affect on human body, the dust must be removed with a dust collector. Never splatter the dust with an air blow gun.

CAUTION:

Never depress the brake pedal. Brake fluid may splash while removing the brake hose.

1. Install disc rotor.

CAUTION:

Align the matching marks put during removal when reusing the disc rotor.

2. Install the brake caliper assembly to the vehicle and tighten the torque member mounting bolts to the specified torque.

CAUTION:

Never spill or splash any grease and moisture on the brake caliper assembly mounting face, threads, mounting bolts and washers. Wipe out any grease and moisture.

3. Install brake hose and copper washers to brake caliper assembly, and tighten union bolts to the specified torque. Refer to [BR-21, "FRONT : Exploded View"](#).

CAUTION:

Never reuse copper washer.

4. Refill with new brake fluid and perform the air bleeding. Refer to [BR-12, "Bleeding Brake System"](#).

CAUTION:

- Never reuse drained brake fluid.
- Never spill or splash brake fluid on the disc rotor.

5. Check a drag of front disc brake. If any drag is found, refer to [BR-41, "BRAKE CALIPER ASSEMBLY \(1 PISTON TYPE\) : Inspection"](#).

BRAKE CALIPER ASSEMBLY (1 PISTON TYPE) : Disassembly and Assembly

INFOID:000000007543282

DISASSEMBLY

NOTE:

Never remove the torque member and pad retainers when disassembling and assembling the cylinder body.

1. Remove the sliding pin bolts, and remove the cylinder body from the torque member.

CAUTION:

Never drop brake pads, shims, shim covers and pad retainers from torque member.

2. Remove brake pads, shims and shim cover. Refer to [BR-34, "BRAKE PAD \(1 PISTON TYPE\) : Exploded View"](#).
3. Remove sliding pins and sliding pin boots from torque member.

FRONT DISC BRAKE

< REMOVAL AND INSTALLATION >

4. Remove bushing from sliding pin.
5. Place a wooden block as shown in the figure, and blow air from union bolt mounting hole to remove piston and piston boot.

CAUTION:

Never get fingers caught in the piston.

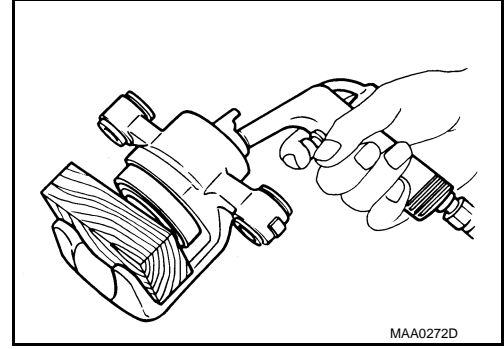

6. Remove piston seal from cylinder body using suitable tool.

CAUTION:

Be careful not to damage a cylinder inner wall.

7. Remove bleeder valve and cap.

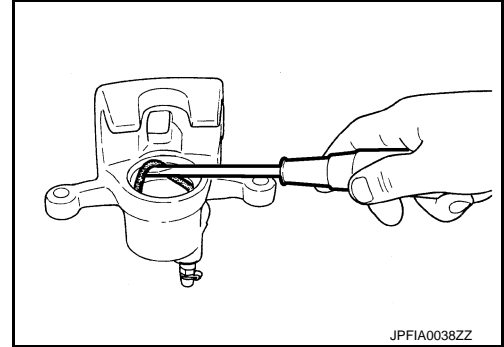

ASSEMBLY

1. Install bleeder valve and cap.
2. Apply polyglycol ether based lubricant to piston seal (1), and install to cylinder body.

CAUTION:

Never reuse piston seal.

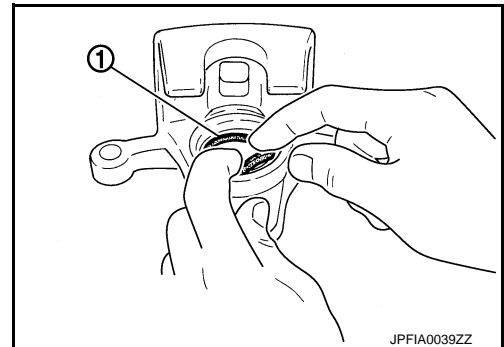

3. Apply rubber grease to piston boot (1). Cover the piston (2) end with piston boot, and then install cylinder side lip on piston boot securely into a groove on cylinder body.

CAUTION:

Never reuse piston boot.

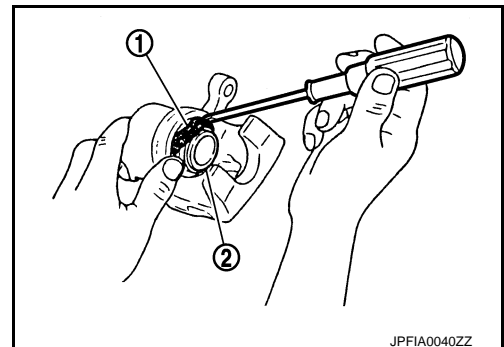

FRONT DISC BRAKE

< REMOVAL AND INSTALLATION >

4. Apply brake fluid to piston (1). Push piston into cylinder body by hand and push piston boot (2) piston-side lip into the piston groove.

CAUTION:

Press the piston evenly and vary the pressing point to prevent cylinder inner wall from being rubbed.

5. Apply rubber grease to bushing, install bushing to sliding pin.
6. Apply rubber grease to sliding pins and sliding pin boots, install sliding pins and sliding pin boots to torque member.
7. Install the cylinder body to the torque member and tighten the sliding pin bolts to the specified torque.

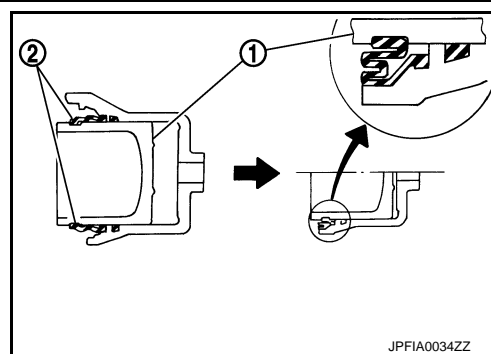

BRAKE CALIPER ASSEMBLY (1 PISTON TYPE) : Inspection

INFOID:000000007543283

INSPECTION AFTER DISASSEMBLY

Cylinder Body

Check the inner wall of the cylinder for rust, wear, cracks or damage. Replace the cylinder if any abnormal condition is detected.

CAUTION:

Always clean with new brake fluid. Never clean with mineral oil such as gasoline and light oil.

Torque Member

Check the torque member for rust, wear, cracks or damage. Replace the member if any abnormal condition is detected.

Piston

Check the surface of the piston for rust, wear, cracks or damage. Replace the piston if any abnormal condition is detected.

CAUTION:

A piston sliding surface is plated. Never polish with sandpaper.

Sliding Pin and Sliding Pin Boot

Check the sliding pins and sliding boots for rust, wear, cracks or damage. Replace the parts if any abnormal condition is detected.

INSPECTION AFTER INSTALLATION

1. Check a drag of front disc brake. If any drag is found, follow the procedure described below.
2. Remove brake pads.
3. Press the piston.

CAUTION:

 - Never damage the piston boot.
 - When replacing a pad with new one, check a brake fluid level in the reservoir tank because brake fluid returns to master cylinder reservoir tank when pressing piston in.

NOTE:

Use a disc brake piston tool to easily press piston.
4. Install brake pads.
5. Depress the brake pedal several times.
6. Check a drag of front disc brake again. If any drag is found, disassemble the cylinder body. Refer to [BR-39. "BRAKE CALIPER ASSEMBLY \(1 PISTON TYPE\) : Disassembly and Assembly"](#).
7. Burnish contact surfaces after refinishing or replacing disc rotors, or if a soft pedal occurs at very low mileage. Refer to [BR-15. "DISC ROTOR : Inspection and Adjustment"](#).

BRAKE CALIPER ASSEMBLY (2 PISTON TYPE)

BRAKE CALIPER ASSEMBLY (2 PISTON TYPE) : Exploded View

INFOID:000000008713762

REMOVAL

FRONT DISC BRAKE

< REMOVAL AND INSTALLATION >

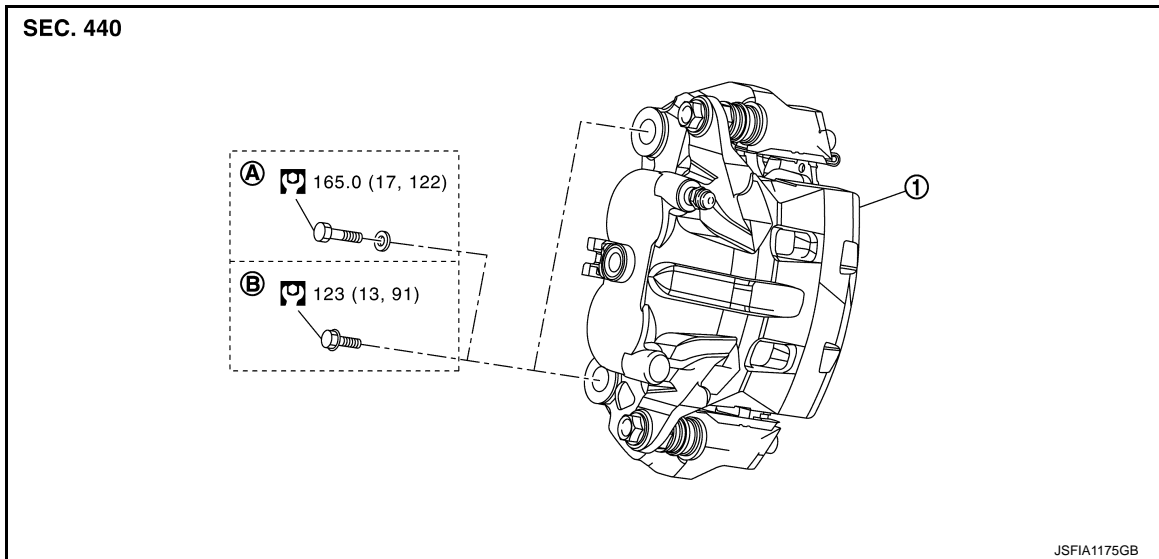

1. Brake caliper assembly
 - A. Hexagon head bolt and washer B. Hexagon flange bolt
- Refer to [GI-4, "Components"](#) for symbols not described on the above.

DISASSEMBLY

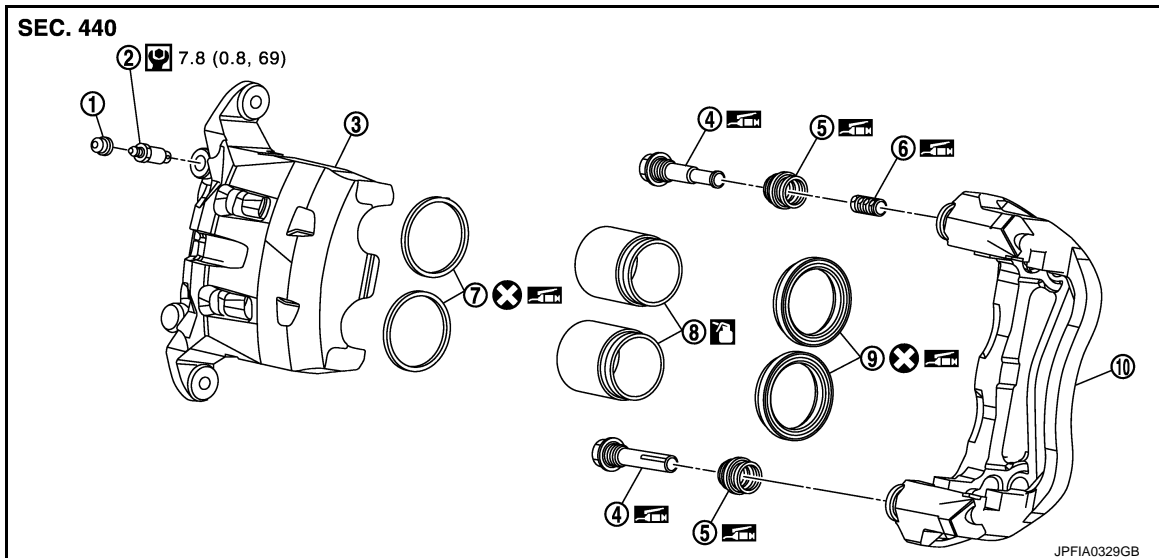

- | | | |
|-------------------|---------------------|------------------|
| 1. Cap | 2. Bleeder valve | 3. Cylinder body |
| 4. Sliding pin | 5. Sliding pin boot | 6. Bushing |
| 7. Piston seal | 8. Piston | 9. Piston boot |
| 10. Torque member | | |

Apply rubber grease.

Apply brake fluid.

Refer to [GI-4, "Components"](#) for symbols not described on the above.

BRAKE CALIPER ASSEMBLY (2 PISTON TYPE) : Removal and Installation

INFOID:000000008713763

REMOVAL

WARNING:

FRONT DISC BRAKE

< REMOVAL AND INSTALLATION >

Since dust covering the front brake has an affect on human body, the dust must be removed with a dust collector. Never splatter the dust with an air blow gun.

CAUTION:

Never depress the brake pedal. Brake fluid may splash while removing the brake hose.

1. Remove tires with power tool.
2. Fix the disc rotor using wheel nuts.
3. Drain brake fluid. Refer to [BR-11, "Draining"](#).

CAUTION:

Never spill or splash brake fluid on the disc rotor.

4. Remove union bolt and copper washers, and then disconnect brake hose from caliper assembly. Refer to [BR-21, "FRONT : Exploded View"](#).
5. Remove torque member mounting bolts, and remove brake caliper assembly.

CAUTION:

Never drop brake pads and caliper assembly.

6. Remove disc rotor.

CAUTION:

- Put matching marks on the wheel hub and bearing assembly and the disc rotor before removing the disc rotor.
- Never drop disc rotor.

INSTALLATION

WARNING:

Since dust covering the front brake has an affect on human body, the dust must be removed with a dust collector. Never splatter the dust with an air blow gun.

CAUTION:

Never depress the brake pedal. Brake fluid may splash while removing the brake hose.

1. Install disc rotor.

CAUTION:

Align the matching marks put during removal when reusing the disc rotor.

2. Install the brake caliper assembly to the vehicle and tighten the torque member mounting bolts to the specified torque.

CAUTION:

Never spill or splash any grease and moisture on the brake caliper assembly mounting face, threads, mounting bolts and washers. Wipe out any grease and moisture.

3. Install brake hose and copper washers to brake caliper assembly, and tighten union bolts to the specified torque. Refer to [BR-21, "FRONT : Exploded View"](#).

CAUTION:

Never reuse copper washer.

4. Refill with new brake fluid and perform the air bleeding. Refer to [BR-12, "Bleeding Brake System"](#).

CAUTION:

- Never reuse drained brake fluid.
- Never spill or splash brake fluid on the disc rotor.

5. Check a drag of front disc brake. If any drag is found, refer to [BR-45, "BRAKE CALIPER ASSEMBLY \(2 PISTON TYPE\) : Inspection"](#).

BRAKE CALIPER ASSEMBLY (2 PISTON TYPE) : Disassembly and Assembly

INFOID:000000008713764

DISASSEMBLY

NOTE:

Never remove the torque member and pad retainers when disassembling and assembling the cylinder body.

1. Remove the sliding pin bolts, and remove the cylinder body from the torque member.

CAUTION:

Never drop brake pads, shims, shim covers and pad retainers from torque member.

2. Remove brake pads, shims and shim covers. Refer to [BR-36, "BRAKE PAD \(2 PISTON TYPE\) : Exploded View"](#).
3. Remove sliding pins and sliding pin boots from torque member.

FRONT DISC BRAKE

< REMOVAL AND INSTALLATION >

4. Remove bushing from sliding pin.
5. Place a wooden block as shown in the figure, and blow air from union bolt mounting hole to remove pistons and piston boots.

CAUTION:

Never get fingers caught in the pistons.

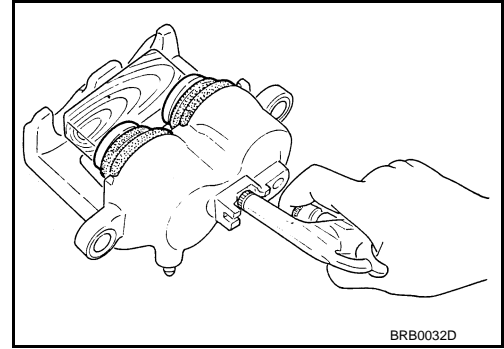

6. Remove piston seals from cylinder body using suitable tool.

CAUTION:

Be careful not to damage a cylinder inner wall.

7. Remove bleeder valve and cap.

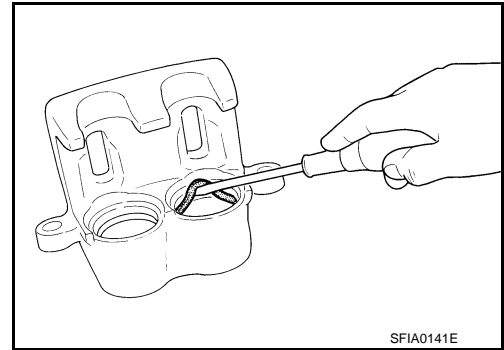

ASSEMBLY

1. Install bleeder valve and cap.
2. Apply rubber grease to piston seals (1), and install to cylinder body.

CAUTION:

Never reuse piston seals.

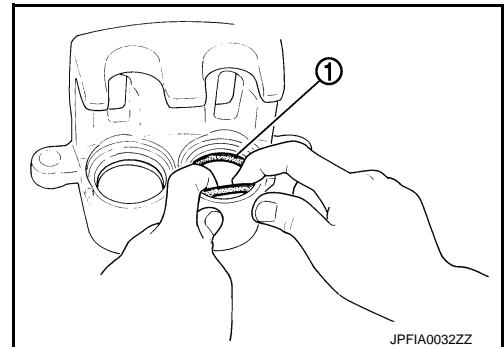

3. Apply rubber grease to piston boots (1). Cover the piston (2) end with piston boot, and then install cylinder side lip on piston boot securely into a groove on cylinder body.

CAUTION:

Never reuse piston boots.

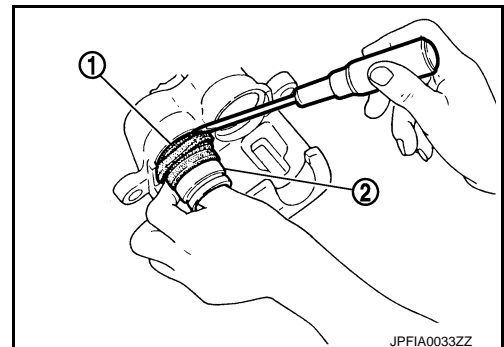

FRONT DISC BRAKE

< REMOVAL AND INSTALLATION >

4. Apply brake fluid to pistons (1). Push piston into cylinder body by hand and push piston boot (2) piston-side lip into the piston groove.

CAUTION:

Press the piston evenly and vary the pressing point to prevent cylinder inner wall from being rubbed.

5. Apply rubber grease to bushing, install bushing to sliding pin.
6. Apply rubber grease to sliding pins and sliding pin boots, install sliding pins and sliding pin boots to torque member.
7. Install the cylinder body to the torque member and tighten the sliding pin bolts to the specified torque.

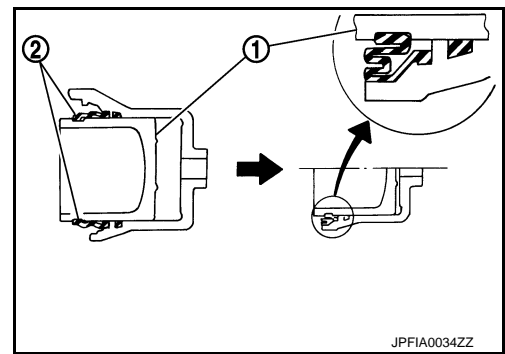

BRAKE CALIPER ASSEMBLY (2 PISTON TYPE) : Inspection

INFOID:000000008713765

INSPECTION AFTER DISASSEMBLY

Cylinder Body

Check the inner wall of the cylinder for rust, wear, cracks or damage. Replace the cylinder if any abnormal condition is detected.

CAUTION:

Always clean with new brake fluid. Never clean with mineral oil such as gasoline and light oil.

Torque Member

Check the torque member for rust, wear, cracks or damage. Replace the member if any abnormal condition is detected.

Pistons

Check the surface of the piston for rust, wear, cracks or damage. Replace the piston if any abnormal condition is detected.

CAUTION:

A piston sliding surface is plated. Never polish with sandpaper.

Sliding Pin and Sliding Pin Boot

Check the sliding pins and sliding boots for rust, wear, cracks or damage. Replace the parts if any abnormal condition is detected.

INSPECTION AFTER INSTALLATION

1. Check a drag of front disc brake. If any drag is found, follow the procedure described below.
2. Remove brake pads.
3. Press the piston.

CAUTION:

 - Never damage the piston boot.
 - When replacing a pad with new one, check a brake fluid level in the reservoir tank because brake fluid returns to master cylinder reservoir tank when pressing piston in.

NOTE:
Use a disc brake piston tool to easily press piston.
4. Install brake pads.
5. Depress the brake pedal several times.
6. Check a drag of front disc brake again. If any drag is found, disassemble the cylinder body. Refer to [BR-43, "BRAKE CALIPER ASSEMBLY \(2 PISTON TYPE\) : Disassembly and Assembly"](#).
7. Burnish contact surfaces after refinishing or replacing disc rotors, or if a soft pedal occurs at very low mileage. Refer to [BR-15, "DISC ROTOR : Inspection and Adjustment"](#).

REAR DISC BRAKE

< REMOVAL AND INSTALLATION >

REAR DISC BRAKE

BRAKE PAD

BRAKE PAD : Exploded View

INFOID:000000007543284

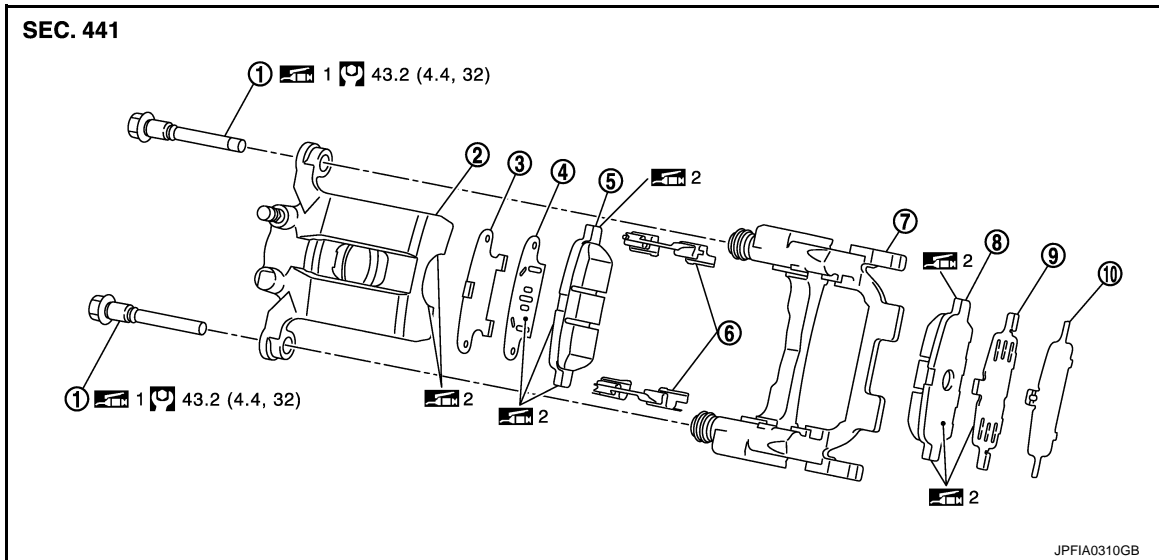

- | | | |
|----------------------|-------------------------------------|---------------------|
| 1. Sliding pin bolt | 2. Cylinder body | 3. Inner shim cover |
| 4. Inner shim | 5. Inner pad (with pad wear sensor) | 6. Pad retainer |
| 7. Torque member | 8. Outer pad | 9. Outer shim |
| 10. Outer shim cover | | |

1: Apply rubber grease.

2: Apply PBC (Poly Butyl Cuprysil) grease or silicone-based grease.

Refer to [GI-4. "Components"](#) for symbols not described on the above.

BRAKE PAD : Removal and Installation

INFOID:000000007543285

REMOVAL

WARNING:

Since dust covering the rear brake has an affect on human body, the dust must be removed with a dust collector. Never splatter the dust with an air blow gun.

CAUTION:

- Never depress the brake pedal while removing the brake pads or the cylinder body because the piston may pop out.
- Never spill or splash brake fluid on the disc rotor.

1. Remove tires with power tool.
2. Remove the upper sliding pin bolt.
3. Suspend the cylinder body with suitable wire so that the brake hose will not stretch. Remove the brake pads, shims and shim cover from the torque member.

CAUTION:

- Never deform the pad retainers if removing the pad retainers.
- Never damage the piston boot.
- Never drop the brake pad, shims, and the shim cover.
- Remember each position of the removed brake pads.

INSTALLATION

WARNING:

Since dust covering the rear brake has an affect on human body, the dust must be removed with a dust collector. Never splatter the dust with an air blow gun.

REAR DISC BRAKE

< REMOVAL AND INSTALLATION >

CAUTION:

- Never depress the brake pedal while removing the brake pads or the cylinder body because the piston may pop out.
- Never spill or splash brake fluid on the disc rotor.

1. Install the pad retainers to the torque member if the pad retainers has been removed.

CAUTION:

- Securely assemble the pad retainers not to be lifted up from the torque member.
- Never deform the pad retainers.

2. Apply PBC (Poly Butyl Cuprysil) grease or silicone-based grease to the mating faces between the brake pads, the shims and pawls part of cylinder body, and install them to the brake pad.

CAUTION:

Always replace the shims together with the shim cover when replacing the brake pad.

3. Install cylinder body and brake pads to torque member.

CAUTION:

- Never damage the piston boot.
- When replacing pads with new one, check a brake fluid level in the reservoir tank because brake fluid returns to master cylinder reservoir tank when pressing piston in.

NOTE:

Use a disc brake piston tool to easily press piston.

4. Install the upper sliding pin bolt and tighten it to the specified torque.

5. Depress the brake pedal several times to check that no drag feel is present for the rear disc brake. Refer to [BR-47. "BRAKE PAD : Inspection"](#).

BRAKE PAD : Inspection

INFOID:000000007543286

INSPECTION AFTER REMOVAL

Replace the shims and the shim cover if rust is excessively attached.

INSPECTION AFTER INSTALLATION

1. Check a drag of rear disc brake. If any drag is found, follow the procedure described below.
2. Remove brake pads.
3. Press the piston.

CAUTION:

- Never damage the piston boot.
- When replacing a pad with new one, check a brake fluid level in the reservoir tank because brake fluid returns to master cylinder reservoir tank when pressing piston in.

NOTE:

Use a disc brake piston tool to easily press piston.

4. Install brake pads.
5. Depress the brake pedal several times.
6. Check a drag of rear disc brake again. If any drag is found, disassemble the cylinder body. Refer to [BR-49. "BRAKE CALIPER ASSEMBLY : Disassembly and Assembly"](#).
7. Burnish contact surfaces after refinishing or replacing pads, or if a soft pedal occurs at very low mileage. Refer to [BR-17. "BRAKE PAD : Inspection and Adjustment"](#).

BRAKE CALIPER ASSEMBLY

BRAKE CALIPER ASSEMBLY : Exploded View

INFOID:000000007543287

REMOVAL

REAR DISC BRAKE

< REMOVAL AND INSTALLATION >

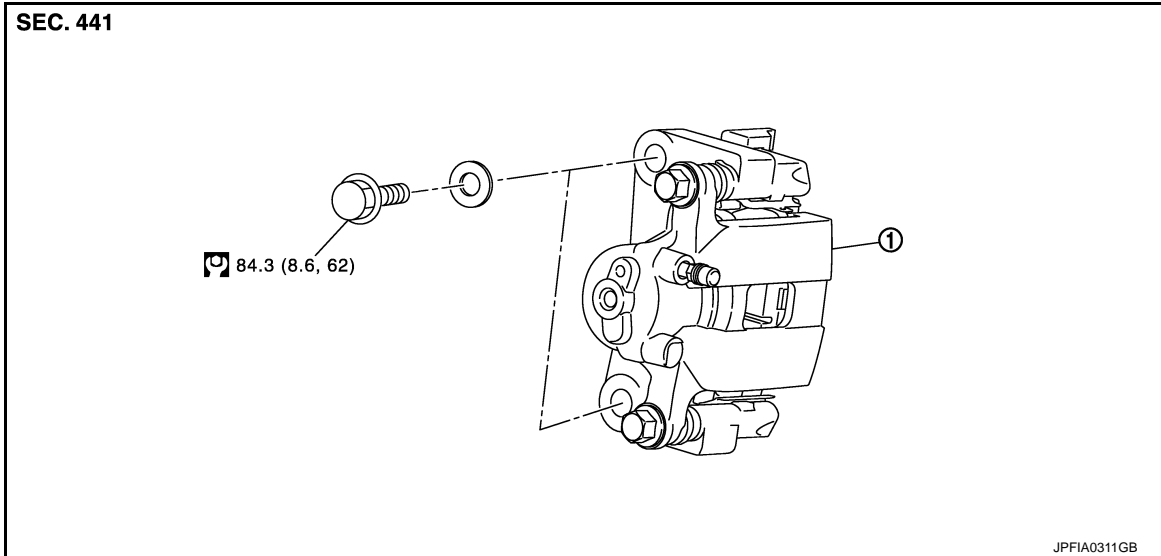

1. Brake caliper assembly

Refer to [GI-4, "Components"](#) for symbols not described on the above.

DISASSEMBLY

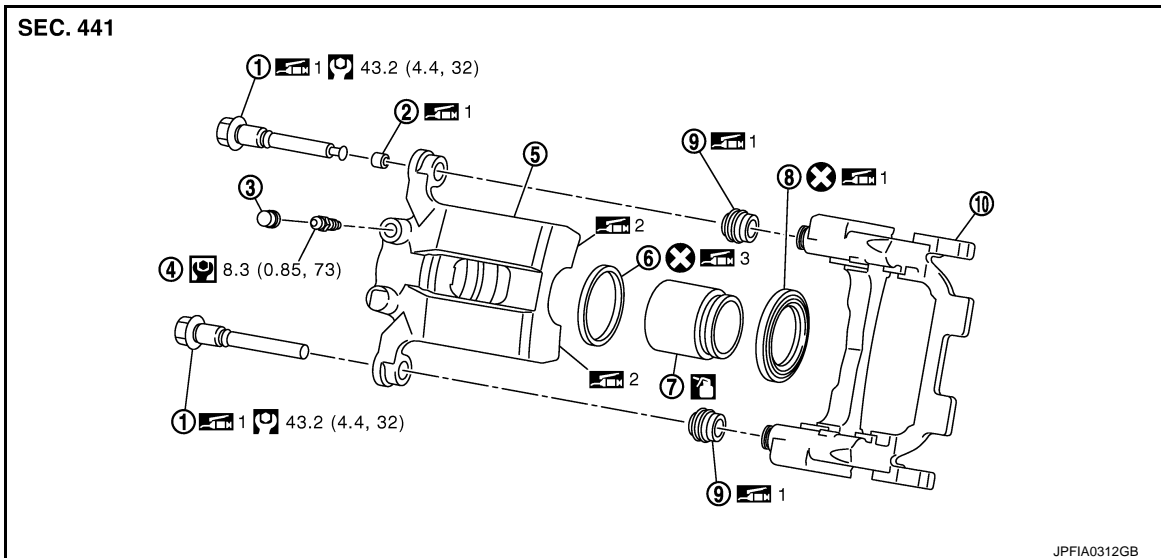

- | | | |
|---------------------|------------------|---------------------|
| 1. Sliding pin bolt | 2. Bushing | 3. Cap |
| 4. Bleeder valve | 5. Cylinder body | 6. Piston seal |
| 7. Piston | 8. Piston boot | 9. Sliding pin boot |
| 10. Torque member | | |

1: Apply rubber grease.

2: Apply PBC (Poly Butyl Cuprysil) grease or silicone-based grease.

3: Apply polyglycol ether based lubricant.

4: Apply brake fluid.

Refer to [GI-4, "Components"](#) for symbols not described on the above.

BRAKE CALIPER ASSEMBLY : Removal and Installation

INFOID:000000007543288

REMOVAL

WARNING:

REAR DISC BRAKE

< REMOVAL AND INSTALLATION >

Since dust covering the rear brake has an affect on human body, the dust must be removed with a dust collector. Never splatter the dust with an air blow gun.

CAUTION:

Never depress the brake pedal. Brake fluid may splash while removing the brake hose.

1. Remove tires with power tool.
2. Fix the disc rotor using wheel nuts.
3. Drain brake fluid. Refer to [BR-11, "Draining"](#).

CAUTION:

Never spill or splash brake fluid on the disc rotor.

4. Remove union bolt and copper washers then disconnect brake hose from caliper assembly.
5. Remove torque member mounting bolts, and remove brake caliper assembly.

CAUTION:

Never drop brake pads and caliper assembly.

6. Remove disc rotor.

CAUTION:

- Put matching marks on the wheel hub and bearing assembly and the disc rotor before removing the disc rotor.
- Never drop disc rotor.

INSTALLATION

WARNING:

Since dust covering the rear brake has an affect on human body, the dust must be removed with a dust collector. Never splatter the dust with an air blow gun.

CAUTION:

Never depress the brake pedal. Brake fluid may splash while removing the brake hose.

1. Install disc rotor.

CAUTION:

Align the matching marks put during removal when reusing the disc rotor.

2. Install the brake caliper assembly to the vehicle and tighten the torque member mounting bolts to the specified torque.

CAUTION:

Never spill or splash any grease and moisture on the brake caliper assembly mounting face, threads, mounting bolts, and washers. Wipe out any grease and moisture.

3. Install brake hose and copper washers to brake caliper assembly, and tighten union bolts to the specified torque. Refer to [BR-23, "REAR : Exploded View"](#).

CAUTION:

Never reuse copper washer.

4. Refill with new brake fluid and perform the air bleeding. Refer to [BR-12, "Bleeding Brake System"](#).

CAUTION:

- Never reuse drained brake fluid.
- Never spill or splash brake fluid on the disc rotor.

5. Check that no drag feel is present for the rear disc brake. Refer to [BR-51, "BRAKE CALIPER ASSEMBLY : Inspection"](#).

BRAKE CALIPER ASSEMBLY : Disassembly and Assembly

INFOID:000000007543289

DISASSEMBLY

NOTE:

Never remove the torque member and pad retainers when disassembling and assembling the cylinder body.

1. Remove the sliding pin bolts and remove the cylinder body from the torque member.
2. Remove brake pads, shims and shim cover. Refer to [BR-46, "BRAKE PAD : Exploded View"](#).
3. Remove sliding pin boots from torque member.
4. Remove bushing from sliding pin bolt.

REAR DISC BRAKE

< REMOVAL AND INSTALLATION >

5. Place a wooden block as shown in the figure, and blow air from union bolt mounting hole to remove piston and piston boot.

CAUTION:

Never get fingers caught in the piston.

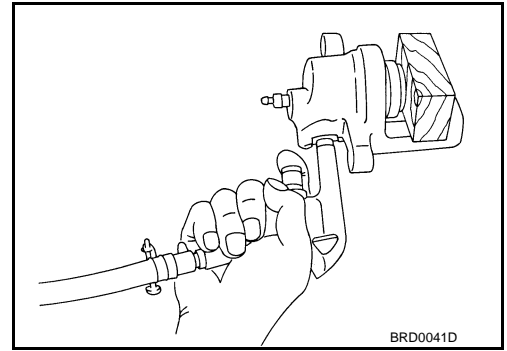

6. Remove piston seal from cylinder body using suitable tool.

CAUTION:

Be careful not to damage a cylinder inner wall.

7. Remove bleeder valve and cap.

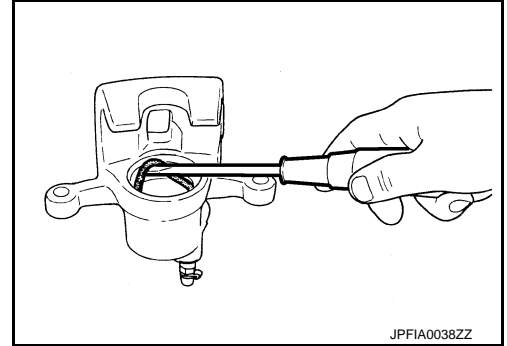

ASSEMBLY

1. Install bleeder valve and cap.
2. Apply polyglycol ether based lubricant to piston seal (1), and install to cylinder body.

CAUTION:

Never reuse piston seal.

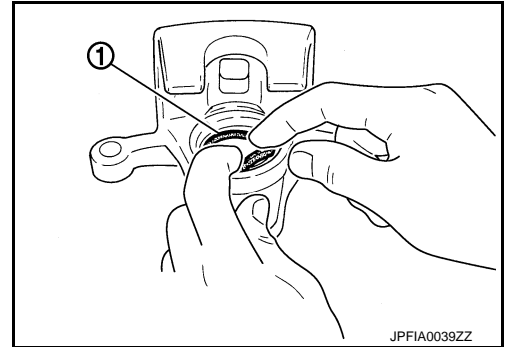

3. Apply rubber grease to piston boot (1). Cover the piston (2) end with the piston boot, and then install cylinder side lip on the piston boot securely into the groove on cylinder body.

CAUTION:

Never reuse piston boot.

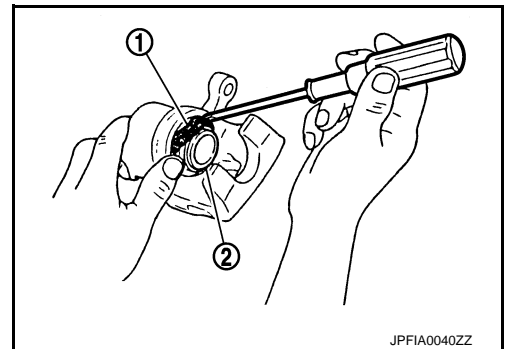

REAR DISC BRAKE

< REMOVAL AND INSTALLATION >

4. Apply brake fluid to piston (1). Push piston into cylinder body by hand and push piston boot (2) piston side lip into the piston groove.

CAUTION:

Press the piston evenly and vary the pressing point to prevent cylinder inner wall from being rubbed.

5. Apply rubber grease to bushing, install bushing to sliding pin bolt.
6. Apply rubber grease to the sliding pin bolts and the sliding pin boots, install sliding pin boot to torque member.
7. Install the cylinder body to the torque member and tighten the sliding pin bolts to the specified torque.

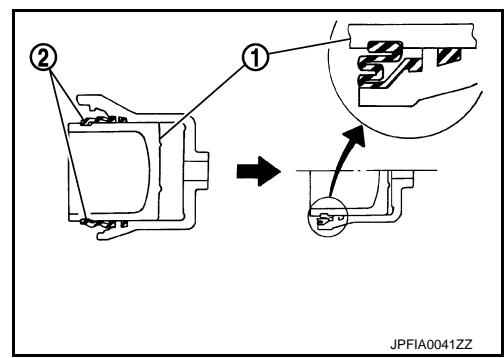

BRAKE CALIPER ASSEMBLY : Inspection

INFOID:000000007543290

INSPECTION AFTER DISASSEMBLY

Cylinder Body

Check the inner wall of the cylinder for rust, wear, cracks or damage. Replace the cylinder if any abnormal condition is detected.

CAUTION:

Always clean with new brake fluid. Never clean with mineral oil such as gasoline and light oil.

Torque Member

Check the torque member for rust, wear, cracks or damage. Replace the member if any abnormal condition is detected.

Piston

Check the piston for rust, wear, cracks or damage. Replace the piston if any abnormal condition is detected.

CAUTION:

A piston sliding surface is plated. Never polish with sandpaper.

Sliding Pin Bolt and Sliding Pin Boot

Check the sliding pin bolts and sliding pin boots for rust, wear, cracks or damage. Replace the parts if any abnormal condition is detected.

INSPECTION AFTER INSTALLATION

1. Check a drag of rear disc brake. If any drag is found, follow the procedure described below.
2. Remove brake pads.
3. Press the piston.

CAUTION:

 - Never damage the piston boot.
 - When replacing a pad with new one, check a brake fluid level in the reservoir tank because brake fluid returns to master cylinder reservoir tank when pressing piston in.

NOTE:

Use a disc brake piston tool to easily press piston.
4. Install brake pads.
5. Depress the brake pedal several times.
6. Check a drag of rear disc brake again. If any drag is found, disassemble the cylinder body. Refer to [BR-49, "BRAKE CALIPER ASSEMBLY : Disassembly and Assembly"](#).
7. Burnish contact surfaces after refinishing or replacing disc rotors, or if a soft pedal occurs at very low mileage. Refer to [BR-17, "DISC ROTOR : Inspection and Adjustment"](#).

SERVICE DATA AND SPECIFICATIONS (SDS)

< SERVICE DATA AND SPECIFICATIONS (SDS)

SERVICE DATA AND SPECIFICATIONS (SDS)

SERVICE DATA AND SPECIFICATIONS (SDS)

General Specifications

INFOID:000000007543291

FRONT CALIPER 1 PISTON TYPE AND REAR CALIPER 1 PISTON TYPE

Unit: mm (in)

Front brake	Cylinder bore diameter		63.6 (2.504)
	Pad length × width × thickness		111.0 × 63.5 × 9.5 (4.37 × 2.500 × 0.374)
	Rotor outer diameter × thickness		φ320 × 28.0 (12.60 × 1.102)
Rear brake	Cylinder bore diameter		42.86 (1.6874)
	Pad length × width × thickness		83.0 × 33.0 × 8.5 (3.268 × 1.299 × 0.335)
	Rotor outer diameter × thickness		φ308 × 16.0 (12.13 × 0.630)
Master cylinder	Cylinder bore diameter		25.4 (1.0)
Control valve	Valve type		Electric brake force distribution
Brake booster	Diaphragm diameter	Primary	228.5 (9.00)
		Secondary	203 (7.99)
Recommended brake fluid			Refer to MA-16, "FOR NORTH AMERICA : Fluids and Lubricants" (for North America), MA-17, "FOR MEXICO : Fluids and Lubricants" (for Mexico).

FRONT CALIPER 2 PISTON TYPE AND REAR CALIPER 1 PISTON TYPE

Unit: mm (in)

Front brake	Cylinder bore diameter		45.0 (1.772) × 2
	Pad length × width × thickness		130.0 × 50.0 × 11.0 (5.12 × 1.969 × 0.433)
	Rotor outer diameter × thickness		φ320 × 28.0 (12.60 × 1.102)
Rear brake	Cylinder bore diameter		42.86 (1.6874)
	Pad length × width × thickness		83.0 × 33.0 × 8.5 (3.268 × 1.299 × 0.335)
	Rotor outer diameter × thickness		φ308 × 16.0 (12.13 × 0.630)
Master cylinder	Cylinder bore diameter		25.4 (1.0)
Control valve	Valve type		Electric brake force distribution
Brake booster	Diaphragm diameter	Primary	228.5 (9.00)
		Secondary	203 (7.99)
Recommended brake fluid			Refer to MA-16, "FOR NORTH AMERICA : Fluids and Lubricants" (for North America), MA-17, "FOR MEXICO : Fluids and Lubricants" (for Mexico).

Brake Pedal

INFOID:000000007543292

Unit: mm (in)

Item	Standard
Brake pedal height	197.1 – 207.1 (7.76 – 8.15)
Clearance between stopper rubber and stop lamp switch and ASCD brake switch threaded end	0.20 – 1.96 (0.0079 – 0.0772)
Brake pedal play	3.0 – 11.0 (0.118 – 0.433)
Depressed brake pedal height [Depressing 490 N (50 kg, 110 lb) while turning the engine ON]	128 (5.04) or more

SERVICE DATA AND SPECIFICATIONS (SDS)

< SERVICE DATA AND SPECIFICATIONS (SDS)

Brake Booster

INFOID:000000007543293

Unit: mm (in)

Item	Standard
Input rod length	127 (5.00)

Front Disc Brake

INFOID:000000007543294

Unit: mm (in)

Item	Limit
Brake pad	Wear thickness 2.0 (0.079)
Disc rotor	Wear thickness 26.0 (1.024)
	Thickness variation (measured at 8 positions) 0.008 (0.0003)
	Runout (with it attached to the vehicle) 0.040 (0.0016) or less

Rear Disc Brake

INFOID:000000007543295

Unit: mm (in)

Item	Limit
Brake pad	Wear thickness 2.0 (0.079)
Disc rotor	Wear thickness 14.0 (0.551)
	Thickness variation (measured at 8 positions) 0.020 (0.0008)
	Runout (with it attached to the vehicle) 0.050 (0.0020) or less

A
B
C
D
E
BR
G
H
I
J
K
L
M
N
O
P