

A
CO
C
D
E
F
G
H
I
J
K
L
M
N
O
P

SECTION CO

ENGINE COOLING SYSTEM

CONTENTS

<p>SYSTEM DESCRIPTION 3</p> <p>DESCRIPTION 3</p> <p style="padding-left: 20px;">Engine Cooling System3</p> <p style="padding-left: 20px;">Engine Cooling System Schematic3</p> <p>SYMPTOM DIAGNOSIS 4</p> <p>OVERHEATING CAUSE ANALYSIS 4</p> <p style="padding-left: 20px;">Troubleshooting Chart4</p> <p>PRECAUTION 6</p> <p>PRECAUTIONS 6</p> <p>FOR USA AND CANADA6</p> <p style="padding-left: 20px;">FOR USA AND CANADA : Precaution for Supplemental Restraint System (SRS) "AIR BAG" and "SEAT BELT PRE-TENSIONER"6</p> <p style="padding-left: 20px;">FOR USA AND CANADA : Liquid Gasket6</p> <p>FOR MEXICO7</p> <p style="padding-left: 20px;">FOR MEXICO : Precaution for Supplemental Restraint System (SRS) "AIR BAG" and "SEAT BELT PRE-TENSIONER"7</p> <p style="padding-left: 20px;">FOR MEXICO : Liquid Gasket8</p> <p>PREPARATION10</p> <p>PREPARATION10</p> <p style="padding-left: 20px;">Special Service Tool10</p> <p style="padding-left: 20px;">Commercial Service Tools10</p> <p>PERIODIC MAINTENANCE11</p> <p>ENGINE COOLANT11</p> <p style="padding-left: 20px;">Inspection11</p> <p style="padding-left: 20px;">Draining11</p> <p style="padding-left: 20px;">Refilling12</p> <p style="padding-left: 20px;">Flushing13</p> <p>RADIATOR15</p>	<p>RADIATOR CAP15</p> <p style="padding-left: 20px;">RADIATOR CAP : Inspection15</p> <p>RADIATOR15</p> <p style="padding-left: 20px;">RADIATOR : Inspection15</p> <p>REMOVAL AND INSTALLATION16</p> <p>RADIATOR16</p> <p style="padding-left: 20px;">Exploded View16</p> <p style="padding-left: 20px;">Removal and Installation17</p> <p style="padding-left: 20px;">Inspection20</p> <p>COOLING FAN21</p> <p style="padding-left: 20px;">Exploded View21</p> <p style="padding-left: 20px;">Removal and Installation21</p> <p style="padding-left: 20px;">Disassembly and Assembly22</p> <p style="padding-left: 20px;">Inspection22</p> <p>WATER PUMP23</p> <p style="padding-left: 20px;">Exploded View23</p> <p style="padding-left: 20px;">Removal and Installation23</p> <p style="padding-left: 20px;">Inspection27</p> <p>WATER INLET AND THERMOSTAT ASSEMBLY28</p> <p style="padding-left: 20px;">Exploded View28</p> <p style="padding-left: 20px;">Removal and Installation28</p> <p style="padding-left: 20px;">Inspection29</p> <p>WATER OUTLET AND WATER PIPING30</p> <p style="padding-left: 20px;">Exploded View30</p> <p style="padding-left: 20px;">Removal and Installation30</p> <p style="padding-left: 20px;">Inspection31</p> <p>SERVICE DATA AND SPECIFICATIONS (SDS)32</p> <p>SERVICE DATA AND SPECIFICATIONS (SDS)32</p> <p style="padding-left: 20px;">Periodical Maintenance Specification32</p> <p style="padding-left: 20px;">Radiator32</p>
--	---

DESCRIPTION

< SYSTEM DESCRIPTION >

SYSTEM DESCRIPTION

DESCRIPTION

Engine Cooling System

INFOID:000000007542443

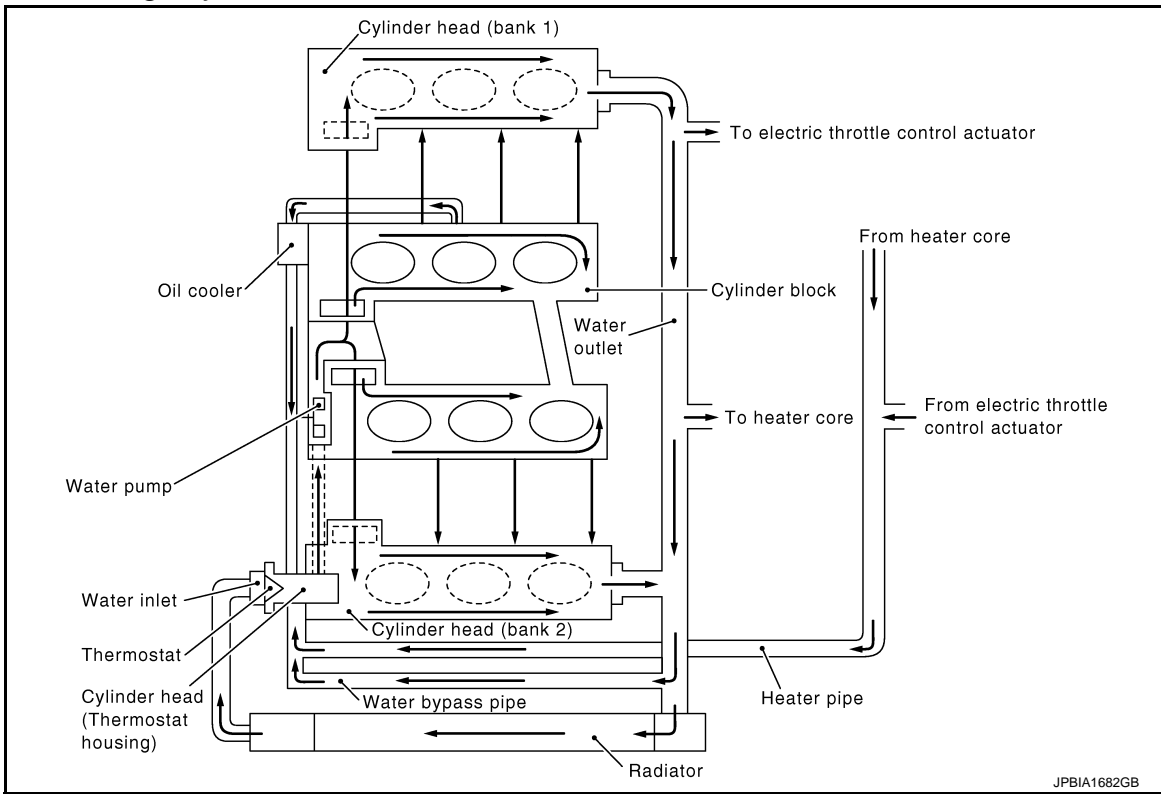

JPBIA1682GB

Engine Cooling System Schematic

INFOID:000000007542444

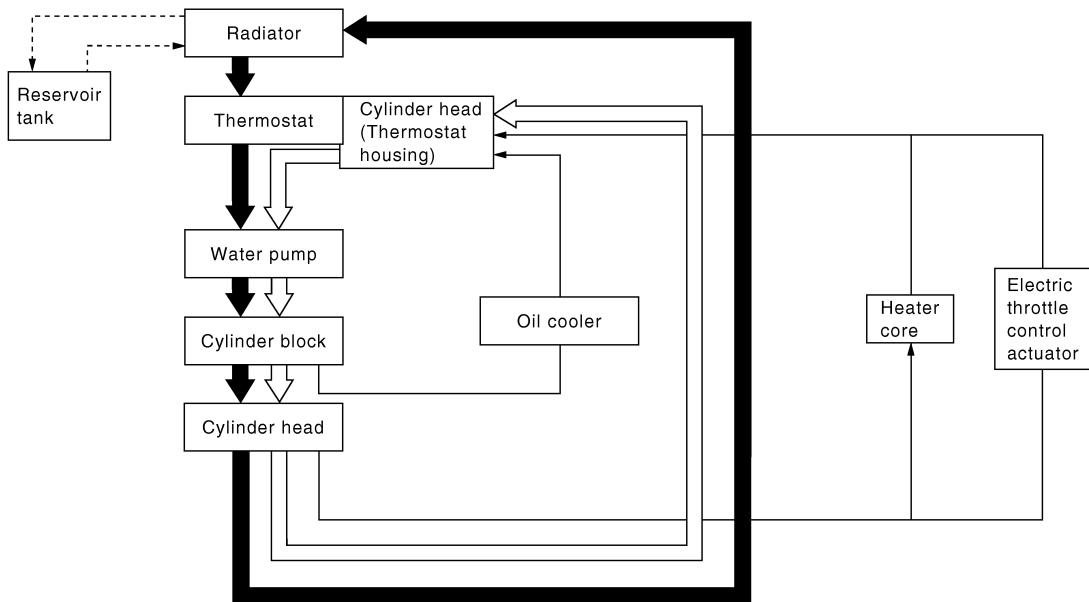

	Thermostat
	Closed
	Open

JPBIA1683GB

OVERHEATING CAUSE ANALYSIS

< SYMPTOM DIAGNOSIS >

SYMPTOM DIAGNOSIS

OVERHEATING CAUSE ANALYSIS

Troubleshooting Chart

INFOID:000000007542445

		Symptom	Check items	
Cooling system parts malfunction	Poor heat transfer	Water pump malfunction	Worn or loose drive belt	—
		Thermostat stuck closed	—	
		Damaged fins	Dust contamination or paper clogging	
			Physical damage	
		Clogged radiator cooling tube	Excess foreign material (rust, dirt, sand, etc.)	
	Reduced air flow	Cooling fan does not operate	Fan assembly	—
		High resistance to fan rotation		
		Damaged fan blades		
		Damaged radiator shroud	—	—
		Improper engine coolant mixture ratio	—	—
		Poor engine coolant quality	—	Engine coolant density
	Insufficient engine coolant	Engine coolant leakage	Cooling hose	Loose clamp
				Cracked hose
			Water pump	Poor sealing
			Radiator cap	Loose
Poor sealing				
Radiator			O-ring for damage, deterioration or improper fitting	
		Cracked radiator tank		
		Cracked radiator core		
		Reservoir tank	Cracked reservoir tank	
Overflowing reservoir tank	Exhaust gas leakage into cooling system	Cylinder head deterioration		
		Cylinder head gasket deterioration		

OVERHEATING CAUSE ANALYSIS

< SYMPTOM DIAGNOSIS >

	Symptom		Check items				
Except cooling system parts malfunction	—	Overload on engine	Abusive driving	High engine rpm under no load	A		
				Driving in low gear for extended time	CO		
				Driving at extremely high speed			
					Powertrain system malfunction		C
					Installed improper size wheels and tires	—	D
					Dragging brakes		
			Improper ignition timing		E		
	Blocked or restricted air flow		Blocked bumper	—			
		Blocked radiator grille		Installed car brassiere			
				Mud contamination or paper clogging	—	F	
			Blocked radiator	—			
			Blocked condenser			G	
	Installed large fog lamp	Blocked air flow					

A
CO
C
D
E
F
G
H
I
J
K
L
M
N
O
P

PRECAUTIONS

< PRECAUTION >

PRECAUTION

PRECAUTIONS

FOR USA AND CANADA

FOR USA AND CANADA : Precaution for Supplemental Restraint System (SRS) "AIR BAG" and "SEAT BELT PRE-TENSIONER"

INFOID:000000007542446

The Supplemental Restraint System such as "AIR BAG" and "SEAT BELT PRE-TENSIONER", used along with a front seat belt, helps to reduce the risk or severity of injury to the driver and front passenger for certain types of collision. This system includes seat belt switch inputs and dual stage front air bag modules. The SRS system uses the seat belt switches to determine the front air bag deployment, and may only deploy one front air bag, depending on the severity of a collision and whether the front occupants are belted or unbelted.

Information necessary to service the system safely is included in the "SRS AIR BAG" and "SEAT BELT" of this Service Manual.

WARNING:

Always observe the following items for preventing accidental activation.

- To avoid rendering the SRS inoperative, which could increase the risk of personal injury or death in the event of a collision that would result in air bag inflation, all maintenance must be performed by an authorized NISSAN/INFINITI dealer.
- Improper maintenance, including incorrect removal and installation of the SRS, can lead to personal injury caused by unintentional activation of the system. For removal of Spiral Cable and Air Bag Module, see "SRS AIR BAG".
- Never use electrical test equipment on any circuit related to the SRS unless instructed to in this Service Manual. SRS wiring harnesses can be identified by yellow and/or orange harnesses or harness connectors.

PRECAUTIONS WHEN USING POWER TOOLS (AIR OR ELECTRIC) AND HAMMERS

WARNING:

Always observe the following items for preventing accidental activation.

- When working near the Air Bag Diagnosis Sensor Unit or other Air Bag System sensors with the ignition ON or engine running, never use air or electric power tools or strike near the sensor(s) with a hammer. Heavy vibration could activate the sensor(s) and deploy the air bag(s), possibly causing serious injury.
- When using air or electric power tools or hammers, always switch the ignition OFF, disconnect the battery, and wait at least 3 minutes before performing any service.

FOR USA AND CANADA : Liquid Gasket

INFOID:000000007542447

REMOVAL OF LIQUID GASKET SEALING

- After removing mounting nuts and bolts, separate the mating surface using the seal cutter [SST: KV10111100 (J-37228)] (A) and remove old liquid gasket sealing.

CAUTION:

Be careful not to damage the mating surfaces.

- Tap (B) the seal cutter [SST: KV10111100 (J-37228)] to insert it, and then slide (C) it by tapping on the side as shown in the figure.
- In areas where seal cutter [SST: KV10111100 (J-37228)] is difficult to use, use a plastic hammer to lightly tap the parts, to remove it.

CAUTION:

If for some unavoidable reason tool such as a screwdriver is used, be careful not to damage the mating surfaces.

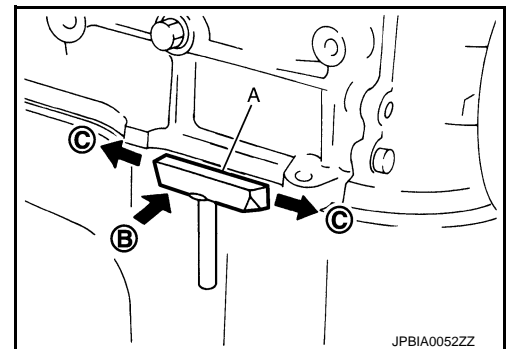

LIQUID GASKET APPLICATION PROCEDURE

PRECAUTIONS

< PRECAUTION >

1. Using a scraper (A), remove old liquid gasket adhering to the liquid gasket application surface and the mating surface.
 - Remove liquid gasket completely from the groove of the liquid gasket application surface, mounting bolts, and bolt holes.
2. Wipe the liquid gasket application surface and the mating surface with white gasoline (lighting and heating use) to remove adhering moisture, grease and foreign materials.

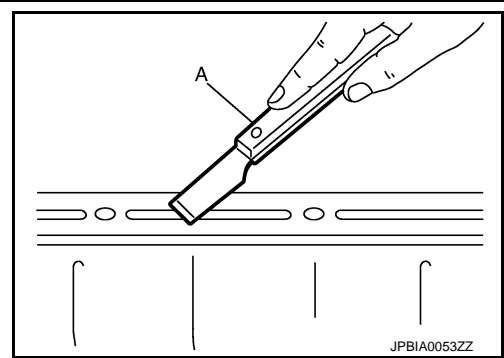

3. Attach liquid gasket tube to the tube presser (commercial service tool).
Use Genuine RTV Silicone Sealant or equivalent. Refer to GI-22. "Recommended Chemical Products and Sealants".
4. Apply liquid gasket without breaks to the specified location with the specified dimensions.
 - If there is a groove for the liquid gasket application, apply liquid gasket to the groove.

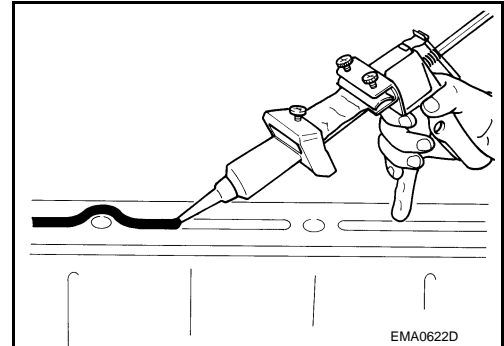

- As for the bolt holes (B), normally apply liquid gasket inside the holes. Occasionally, it should be applied outside the holes. Check to read the text of service manual.

A : Groove

⇐ : Inside

- Within five minutes of liquid gasket application, install the mating component.
- If liquid gasket protrudes, wipe it off immediately.
- Never retighten after mounting bolts and nuts the installation.
- After 30 minutes or more have passed from the installation, fill engine oil and engine coolant.

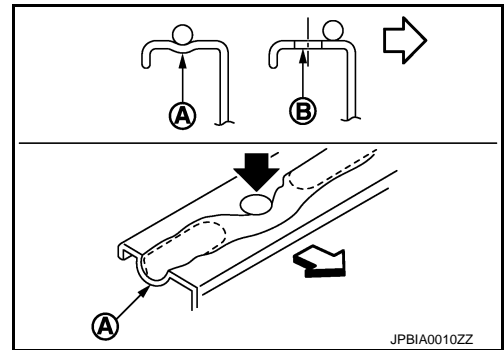

CAUTION:

If there are specific instructions in this manual, observe them.

FOR MEXICO

FOR MEXICO : Precaution for Supplemental Restraint System (SRS) "AIR BAG" and "SEAT BELT PRE-TENSIONER"

INFOID:000000007542448

The Supplemental Restraint System such as "AIR BAG" and "SEAT BELT PRE-TENSIONER", used along with a front seat belt, helps to reduce the risk or severity of injury to the driver and front passenger for certain types of collision. Information necessary to service the system safely is included in the "SRS AIR BAG" and "SEAT BELT" of this Service Manual.

WARNING:

Always observe the following items for preventing accidental activation.

- To avoid rendering the SRS inoperative, which could increase the risk of personal injury or death in the event of a collision that would result in air bag inflation, all maintenance must be performed by an authorized NISSAN/INFINITI dealer.
- Improper maintenance, including incorrect removal and installation of the SRS, can lead to personal injury caused by unintentional activation of the system. For removal of Spiral Cable and Air Bag Module, see "SRS AIR BAG".
- Never use electrical test equipment on any circuit related to the SRS unless instructed to in this Service Manual. SRS wiring harnesses can be identified by yellow and/or orange harnesses or harness connectors.

PRECAUTIONS

< PRECAUTION >

PRECAUTIONS WHEN USING POWER TOOLS (AIR OR ELECTRIC) AND HAMMERS

WARNING:

Always observe the following items for preventing accidental activation.

- When working near the Air Bag Diagnosis Sensor Unit or other Air Bag System sensors with the ignition ON or engine running, never use air or electric power tools or strike near the sensor(s) with a hammer. Heavy vibration could activate the sensor(s) and deploy the air bag(s), possibly causing serious injury.
- When using air or electric power tools or hammers, always switch the ignition OFF, disconnect the battery, and wait at least 3 minutes before performing any service.

FOR MEXICO : Liquid Gasket

INFOID:000000007542449

REMOVAL OF LIQUID GASKET SEALING

- After removing mounting nuts and bolts, separate the mating surface using the seal cutter [SST: KV10111100 (J-37228)] (A) and remove old liquid gasket sealing.

CAUTION:

Be careful not to damage the mating surfaces.

- Tap (B) the seal cutter [SST: KV10111100 (J-37228)] to insert it, and then slide (C) it by tapping on the side as shown in the figure.
- In areas where seal cutter [SST: KV10111100 (J-37228)] is difficult to use, use a plastic hammer to lightly tap the parts, to remove it.

CAUTION:

If for some unavoidable reason tool such as a screwdriver is used, be careful not to damage the mating surfaces.

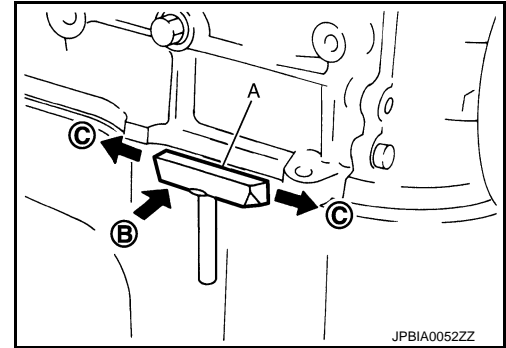

LIQUID GASKET APPLICATION PROCEDURE

1. Using a scraper (A), remove old liquid gasket adhering to the liquid gasket application surface and the mating surface.
 - Remove liquid gasket completely from the groove of the liquid gasket application surface, mounting bolts, and bolt holes.
2. Wipe the liquid gasket application surface and the mating surface with white gasoline (lighting and heating use) to remove adhering moisture, grease and foreign materials.

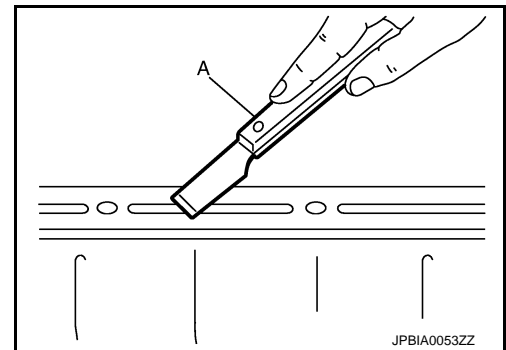

3. Attach liquid gasket tube to the tube presser (commercial service tool).
Use Genuine RTV Silicone Sealant or equivalent. Refer to [GI-22, "Recommended Chemical Products and Sealants"](#).
4. Apply liquid gasket without breaks to the specified location with the specified dimensions.
 - If there is a groove for the liquid gasket application, apply liquid gasket to the groove.

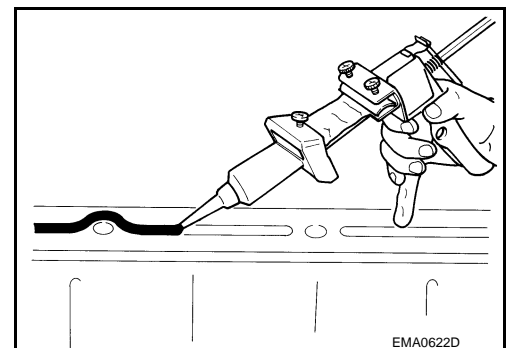

PRECAUTIONS

< PRECAUTION >

- As for the bolt holes (B), normally apply liquid gasket inside the holes. Occasionally, it should be applied outside the holes. Check to read the text of service manual.

A : Groove

⇐ : Inside

- Within five minutes of liquid gasket application, install the mating component.
- If liquid gasket protrudes, wipe it off immediately.
- Never retighten after mounting bolts and nuts the installation.
- After 30 minutes or more have passed from the installation, fill engine oil and engine coolant.

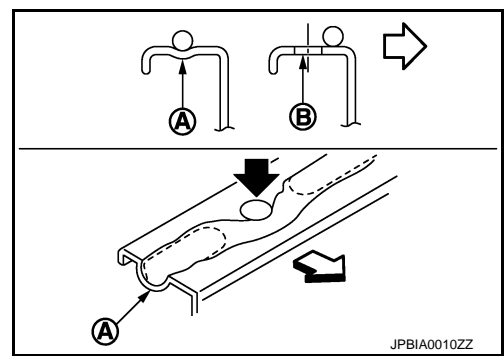

CAUTION:

If there are specific instructions in this manual, observe them.

A

CO

C

D

E

F

G

H

I

J

K

L

M

N

O

P

PREPARATION

< PREPARATION >

PREPARATION

PREPARATION

Special Service Tool

INFOID:000000007542450

The actual shapes of Kent-Moore tools may differ from those of special service tools illustrated here.

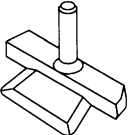
Tool number (Kent-Moore No.) Tool name	Description
KV10111100 (J-37228) Seal cutter  NT046	Removing water pump cover

Commercial Service Tools

INFOID:000000007542451

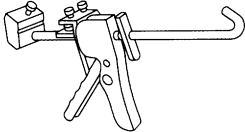
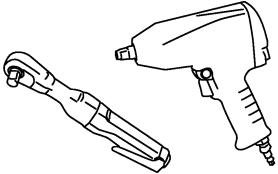
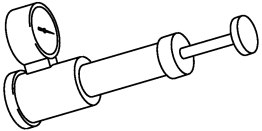
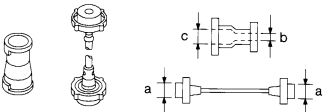
Tool name	Description
Tube presser  S-NT052	Pressing the tube of liquid gasket
Power tool  PBIC0190E	Loosening nuts and bolts
Radiator cap tester  PBIC1982E	Checking radiator and radiator cap
Radiator cap tester adapter  S-NT564	Adapting radiator cap tester to radiator cap and radiator pipe (upper) filler neck a: 28 (1.10) dia. b: 31.4 (1.236) dia. c: 41.3 (1.626) dia. Unit: mm (in)

ENGINE COOLANT

< PERIODIC MAINTENANCE >

PERIODIC MAINTENANCE

ENGINE COOLANT

Inspection

INFOID:000000007542452

LEVEL

- Check if the reservoir tank engine coolant level is within the “MIN” to “MAX” when the engine is cool.

A : MAX
B : MIN

- Adjust the engine coolant level if necessary.

CAUTION:

Refill Genuine NISSAN Long Life Antifreeze/Coolant (blue) or equivalent in its quality mixed with water (distilled or demineralized). Refer to [MA-16, "FOR NORTH AMERICA : Fluids and Lubricants"](#) (FOR NORTH AMERICA). or [MA-17, "FOR MEXICO : Fluids and Lubricants"](#) (FOR MEXICO).

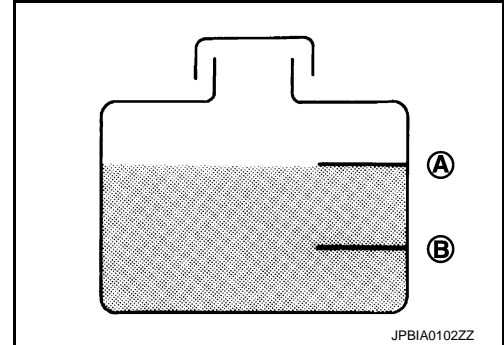

LEAKAGE

- To check for leakage, apply pressure to the cooling system with the radiator cap tester (commercial service tool) (A) and radiator cap tester adapter (commercial service tool) (B).

Testing pressure : Refer to [CO-32, "Radiator"](#).

WARNING:

Never remove radiator cap when engine is hot. Serious burns could occur from high-pressure engine coolant escaping from radiator.

CAUTION:

Higher test pressure than specified may cause radiator damage.

NOTE:

In a case that engine coolant decreases, replenish radiator with engine coolant.

- If anything is found, repair or replace damaged parts.

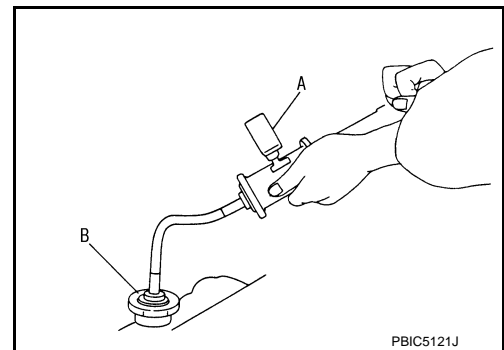

Draining

INFOID:000000007542453

WARNING:

- To avoid being scalded, never change engine coolant when the engine is hot.
- Wrap a thick cloth around radiator cap and carefully remove radiator cap. First, turn radiator cap a quarter of a turn to release built-up pressure. Then turn radiator cap all the way.

1. Remove engine under cover.
2. Open radiator drain plug (1) at the bottom of radiator, and then remove radiator cap.

← : Vehicle front

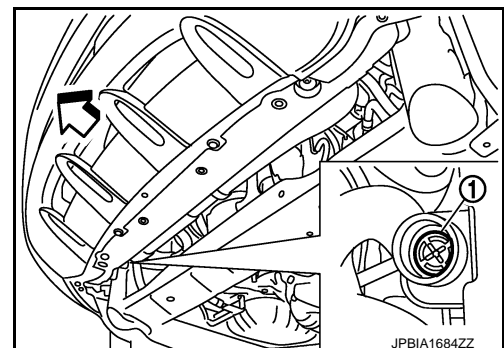

When draining all of engine coolant in the system, open water drain plugs on cylinder block. Refer to [EM-90, "Setting"](#).

ENGINE COOLANT

< PERIODIC MAINTENANCE >

3. Remove reservoir tank if necessary, and drain engine coolant and clean reservoir tank before installing.
4. Check drained engine coolant for contaminants such as rust, corrosion or discoloration.
If contaminated, flush the engine cooling system. Refer to [CO-13, "Flushing"](#).

Refilling

INFOID:000000007542454

CAUTION:

- Do not reuse O-rings.
- Do not put additive such as waterleak preventive, since it may cause cooling waterway clogging.
- When refilling use Genuine NISSAN Long Life Antifreeze/Coolant (blue) or equivalent in its quality mixed with water (distilled or demineralized). Refer to [MA-16, "FOR NORTH AMERICA : Fluids and Lubricants"](#) (for North America) or Refer to [MA-17, "FOR MEXICO : Fluids and Lubricants"](#) (for Mexico).

1. Install reservoir tank if removed and radiator drain plug.

CAUTION:

Be sure to clean drain plug and install with new O-ring.

Tightening torque : Refer to [CO-16, "Exploded View"](#).

If water drain plugs on cylinder block are removed, close and tighten them. Refer to [EM-123, "Disassembly and Assembly"](#).

2. Check that each hose clamp has been firmly tightened.
3. Remove air duct assembly and air cleaner cases (upper and lower) assembly. Refer to [EM-31, "Exploded View"](#).
4. Disconnect heater hose (1) at the position (◀) in the figure.

◀ : Vehicle front

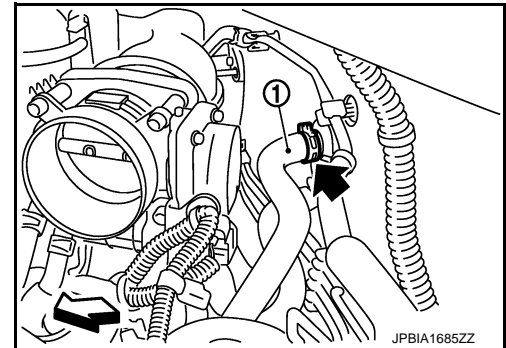

5. Fill radiator, and reservoir tank if removed, to specified level.

CAUTION:

Never adhere the engine coolant to electronic equipments. (alternator etc.)

- Pour engine coolant through engine coolant filler neck slowly of less than 2 ℓ (2-1/8 US qt, 1-3/4 Imp qt) a minute to allow air in system to escape.
- When engine coolant overflows disconnected heater hose, connect heater hose, and continue filling the engine coolant.

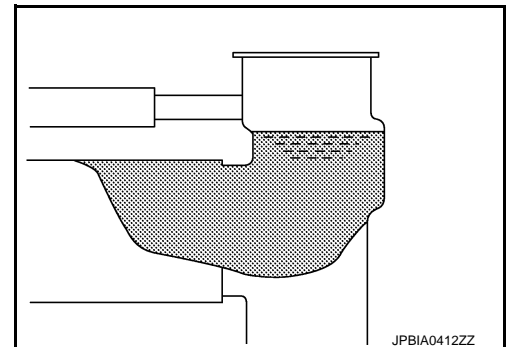

Engine coolant capacity
(With reservoir tank at "MAX" level)

: Refer to [CO-32, "Periodical Maintenance Specification"](#).

Reservoir tank engine coolant capacity
(At "MAX" level)

: Refer to [CO-32, "Periodical Maintenance Specification"](#).

ENGINE COOLANT

< PERIODIC MAINTENANCE >

A : MAX
B : MIN

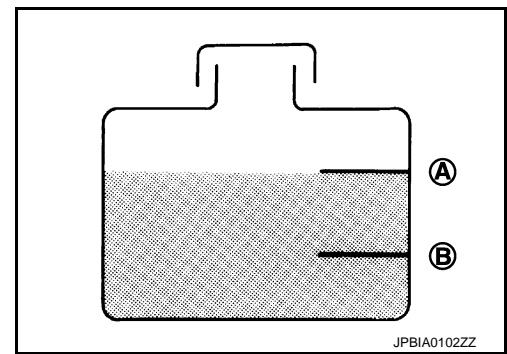

6. Install air duct assembly and air cleaner cases (upper and lower) assembly. Refer to [EM-31, "Exploded View"](#).
7. Install radiator cap.
8. Warm up engine until opening thermostat. Standard for warming-up time is approximately 10 minutes at 3,000 rpm.
 - Check thermostat opening condition by touching radiator hose (lower) to see a flow of warm water.**CAUTION:**
Watch water temperature gauge so as not to overheat engine.
9. Stop the engine and cool down to less than approximately 50°C (122°F).
 - Cool down using fan to reduce the time.
 - If necessary, refill radiator up to filler neck with engine coolant.**CAUTION:**
Never adhere the engine coolant to electronic equipments. (alternator etc.)
10. Refill reservoir tank to "MAX" level line with engine coolant.
11. Repeat steps 7 through 10 two or more times with radiator cap installed until engine coolant level no longer drops.
12. Check cooling system for leakage with engine running.
13. Warm up the engine, and check for sound of engine coolant flow while running engine from idle up to 3,000 rpm with heater temperature controller set at several position between "COOL" and "WARM".
 - Sound may be noticeable at heater unit.
14. Repeat step 13 three times.
15. If sound is heard, bleed air from cooling system by repeating step 5, and steps from 7 to 14 until engine coolant level no longer drops.

Flushing

INFOID:000000007542455

1. Install reservoir tank if removed and radiator drain plug.
CAUTION:
Be sure to clean drain plug and install with new O-ring.

Tightening torque : Refer to [CO-16, "Exploded View"](#).
If water drain plugs on cylinder block are removed, close and tighten them. Refer to [EM-123, "Dis-assembly and Assembly"](#).
2. Remove air duct assembly and air cleaner cases (upper and lower) assembly. Refer to [EM-31, "Exploded View"](#).

ENGINE COOLANT

< PERIODIC MAINTENANCE >

3. Disconnect heater hose (1) at the position (←) in the figure.

← : Vehicle front

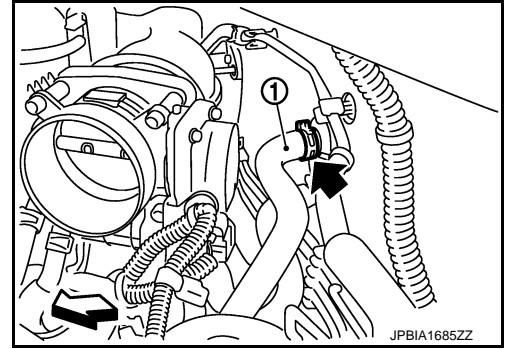

4. Fill radiator and reservoir tank with water and reinstall radiator cap.
CAUTION:
Never adhere the water to electronic equipments. (alternator etc.)
 - **When water overflows disconnected heater hose, connect heater hose, and continue filling the water.**
5. Run the engine and warm it up to normal operating temperature.
6. Rev the engine two or three times under no-load.
7. Stop the engine and wait until it cools down.
8. Drain water from the system. Refer to [CO-11, "Draining"](#).
9. Repeat steps 1 through 8 until clear water begins to drain from radiator.

RADIATOR

< PERIODIC MAINTENANCE >

RADIATOR

RADIATOR CAP

RADIATOR CAP : Inspection

INFOID:000000007542456

- Check valve seat (A) of radiator cap.
- Check if valve seat is swollen to the extent that the edge of the plunger (B) cannot be seen when watching it vertically from the top.
- Check if valve seat has no soil and damage.
- Check that there is no dirt or damage on the valve seat of radiator cap negative-pressure valve.
- Check that there are no unusualness in the opening and closing conditions of negative-pressure valve.

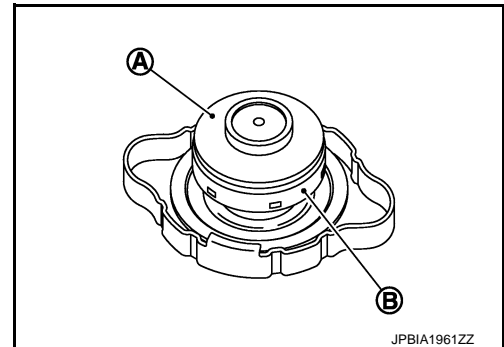

- Check radiator cap relief pressure.

Standard and limit : Refer to [CO-32, "Radiator"](#).

- When connecting radiator cap to the radiator cap tester (commercial service tool) and the radiator cap tester adapter (commercial service tool) (A), apply engine coolant to the cap seal surface.

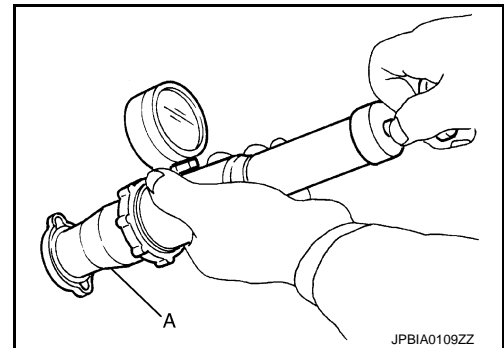

- Replace radiator cap if there is an unusualness related to the above three.

CAUTION:

When installing radiator cap, thoroughly wipe out the radiator pipe (upper) filler neck to remove any waxy residue or foreign material.

RADIATOR

RADIATOR : Inspection

INFOID:000000007542457

Check radiator for mud or clogging. If necessary, clean radiator as follows:

CAUTION:

- **Be careful not to bend or damage radiator fins.**
 - **When radiator is cleaned without removal, remove all surrounding parts such as radiator cooling fan assembly and horns. Then tape harness and connectors to prevent water from entering.**
1. Apply water by hose to the back side of the radiator core vertically downward.
 2. Apply water again to all radiator core surfaces once per minute.
 3. Stop washing if any stains no longer flow out from radiator.
 4. Blow air into the back side of radiator core vertically downward.
 - Use compressed air lower than 490 kPa (5 kg/cm², 71 psi) and keep distance more than 30 cm (11.81 in).
 5. Blow air again into all the radiator core surfaces once per minute until no water sprays out.

RADIATOR

< REMOVAL AND INSTALLATION >

REMOVAL AND INSTALLATION

RADIATOR

Exploded View

INFOID:000000007542458

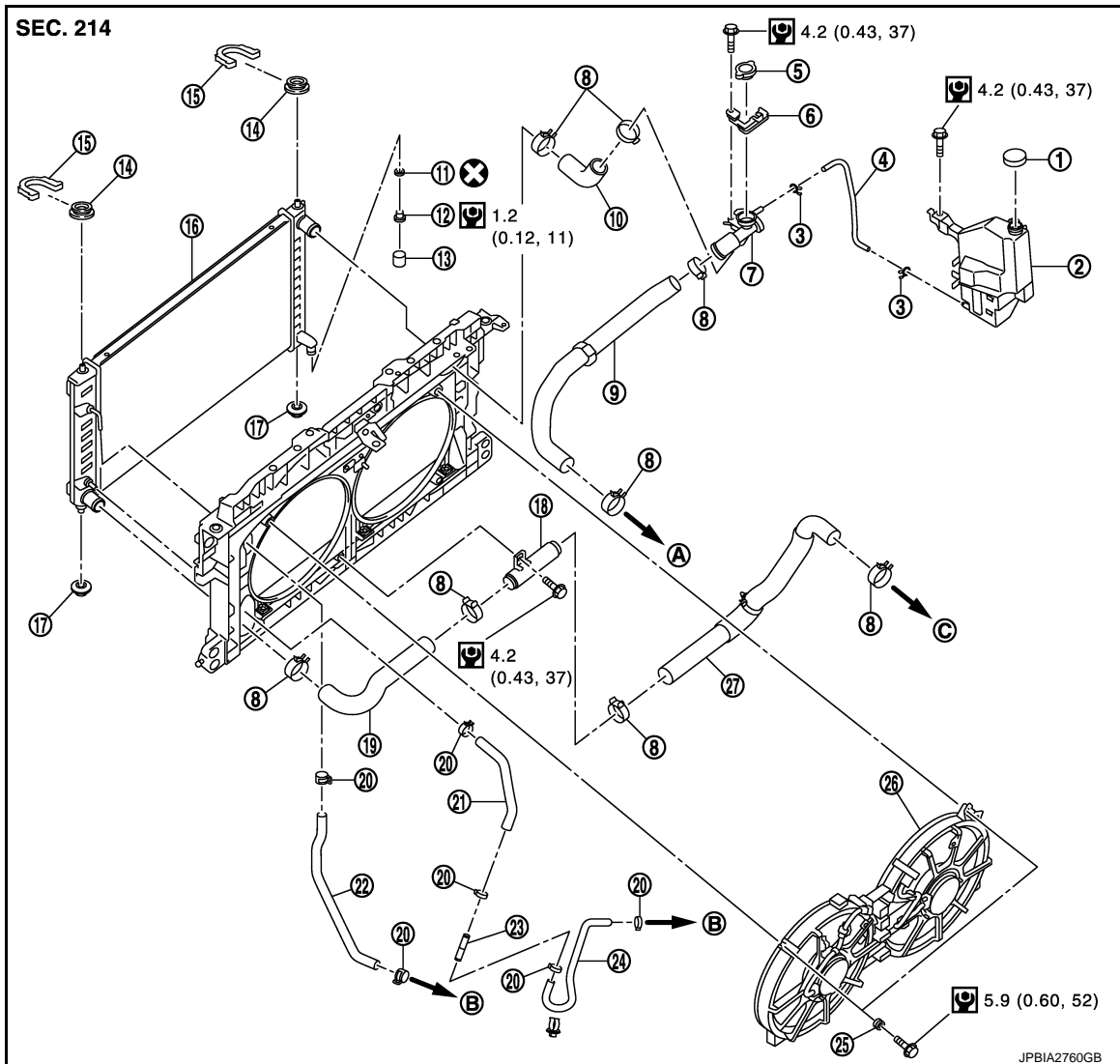

- | | | |
|---------------------------|-----------------------------|---------------------------|
| 1. Reservoir tank cap | 2. Reservoir tank | 3. Clamp |
| 4. Reservoir tank hose | 5. Radiator cap | 6. Radiator cap adapter |
| 7. Radiator pipe (upper) | 8. Clamp | 9. Radiator hose (upper) |
| 10. Radiator hose (upper) | 11. O-ring | 12. Drain plug |
| 13. Water drain hose | 14. Mounting rubber (upper) | 15. Radiator upper clip |
| 16. Radiator | 17. Mounting rubber (lower) | 18. Radiator pipe (lower) |
| 19. Radiator hose (lower) | 20. Clamp | 21. CVT fluid cooler hose |
| 22. CVT fluid cooler hose | 23. CVT fluid cooler pipe | 24. CVT fluid cooler hose |
| 25. Grommet | 26. Cooling fan assembly | 27. Radiator hose (lower) |
| A. To water outlet | B. To transaxle assembly | C. To water inlet |

⊗ : Always replace after every disassembly.

🔧 : N·m (kg·m, in·lb)

RADIATOR

< REMOVAL AND INSTALLATION >

Removal and Installation

INFOID:000000007542459

REMOVAL

WARNING:

Never remove radiator cap when engine is hot. Serious burns could occur from high-pressure engine coolant escaping from radiator. Wrap a thick cloth around the cap. Slowly turn it a quarter of a turn to release built-up pressure. Carefully remove radiator cap by turning it all the way.

1. Remove the following parts:
 - Engine under cover.
 - Radiator core support covers (RH and LH): Refer to [EM-31, "Exploded View"](#).
 - Air duct (inlet): Refer to [EM-31, "Exploded View"](#).
 - Front grille: Refer to [EXT-18, "Exploded View"](#).
 - Horn: Refer to [HRN-5, "Exploded View"](#).
 - Hood lock: Refer to [DLK-293, "Exploded View"](#).
2. Drain engine coolant from radiator. Refer to [CO-11, "Draining"](#).

CAUTION:

- Perform this step when the engine is cold.
- Never spill engine coolant on drive belt.

3. Disconnect reservoir tank hose from radiator pipe (upper).
4. Disconnect CVT fluid cooler hoses from radiator.
 - Install blind plug to avoid leakage of CVT fluid.
5. Remove radiator cap adapter and each radiator hoses (upper) and radiator pipe (upper) assembly.

CAUTION:

Be careful not to allow engine coolant to contact drive belt.

6. Disconnect radiator hose (lower) from radiator.
7. Remove condenser. Refer to [HA-49, "Exploded View"](#).

CAUTION:

Be careful not to damage condenser core.

8. Remove each radiator upper clips (2) by pulling the tabs (A) outside to release the lock (B) and then remove each mounting rubbers (upper) (1).

C : Mounting pin

↔ : Vehicle front

CAUTION:

Never pull the tabs outside excessively to prevent it from damping.

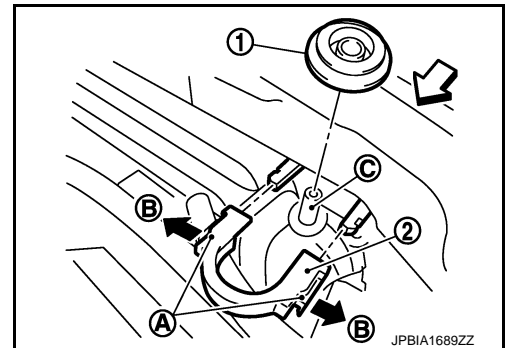

9. Lift up and remove radiator (1) from front of radiator core support (2).

↔ : Vehicle front

CAUTION:

Be careful not to damage or scratch on radiator core.

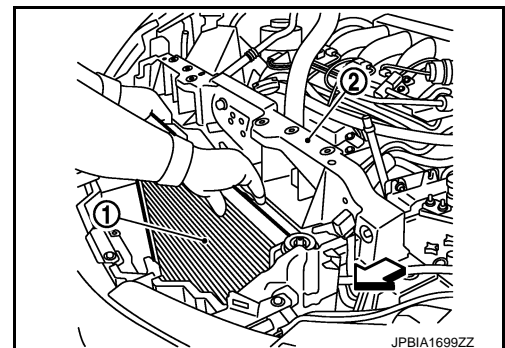

INSTALLATION

CAUTION:

Do not reuse O-rings.

Note the following, and install in the reverse order of removal.

Radiator Upper Clip

RADIATOR

< REMOVAL AND INSTALLATION >

Install each radiator upper clips on radiator core connection as follows:

1. Install each mounting rubbers (upper) (1) on mounting pins (A) of radiator.

← : Vehicle front

2. Align each radiator upper clips (2) with radiator core connection (B), then insert each radiator upper clips straight into radiator core connections until a click is heard.
3. After connecting each radiator upper clips, use the following method to check it is fully connected.
 - Visually confirm that each radiator upper clips are connected to radiator core connections.
 - Move each radiator upper clips and the radiator forward and backward to check they are securely connected.

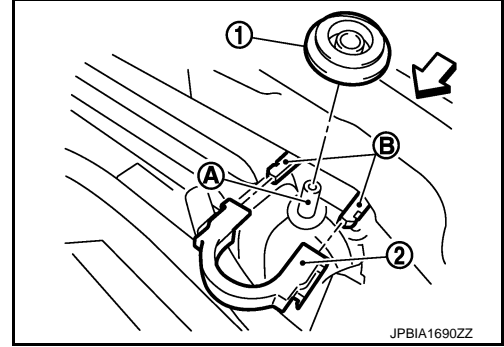

Radiator hose

CAUTION:

- Use genuine mounting bolts for the cooling fan assembly and strictly observe the tightening torque. (Breakage prevention for radiator)

NOTE:

- Insert the radiator hose (1) all the way to the stopper (2) or by 33 mm (1.30 in) (hose without a stopper).

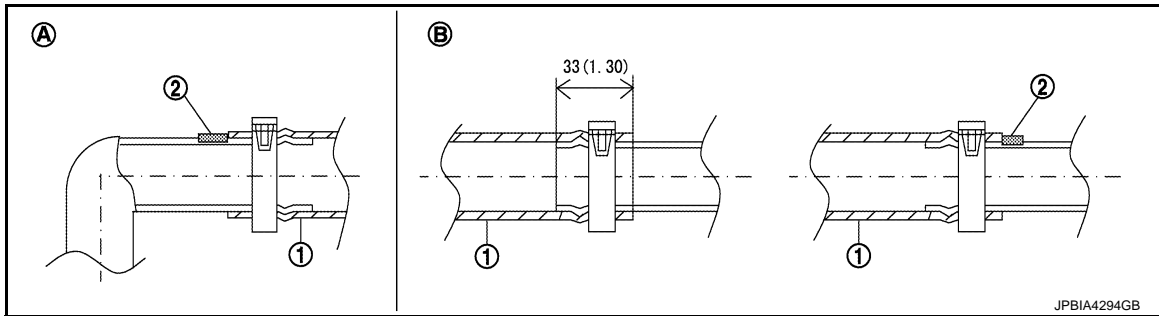

Unit mm (in)

A. Radiator side

B. Engine side

- For the orientation of the hose clamp pawl, refer to the figure.

Radiator hose	Hose end	Paint mark	Position of hose clamp*
Radiator hose (upper)	Radiator side	Right side	C
	Radiator pipe radiator side	No marking	B
	Radiator pipe engine side	No marking	C
	Engine side	Upper	D
Radiator hose (lower)	Radiator side	Upper	A
	Radiator pipe radiator side	No marking	A
	Radiator pipe engine side	No marking	A
	Engine side	Upper	E

*Refer to the illustrations for the specific position each hose clamp tab.

RADIATOR

< REMOVAL AND INSTALLATION >

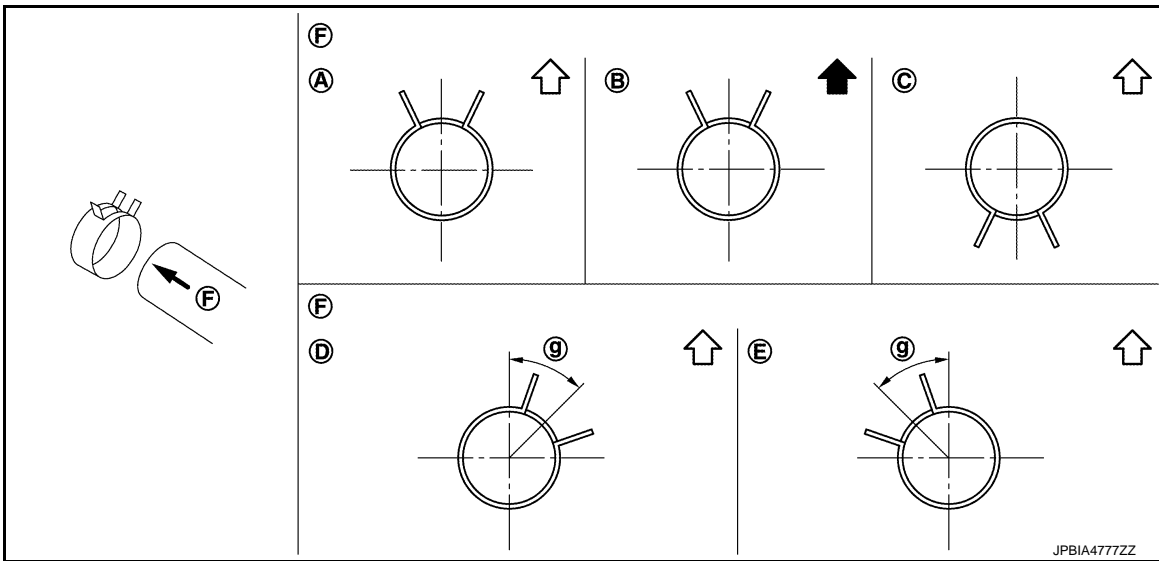

F. View F

g. 45°

↕ Vehicle upper

← Vehicle rear

- The angle (b) created by the hose clamp pawl and the specified line (A) must be within $\pm 15^\circ$ as shown in the figure.

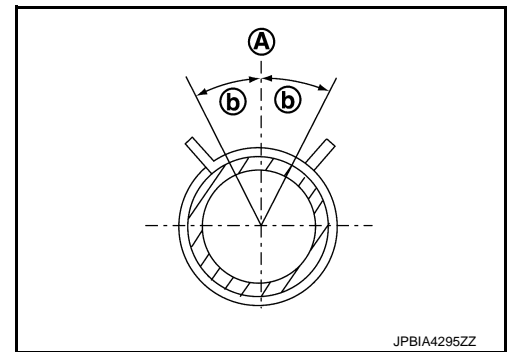

With paint mark

- To install hose clamps (1), check that the dimension (A) from the end of the paint mark (2) on the radiator hose to the hose clamp is within the reference value.

Dimension "A"

(-1) – (+1) mm

(-0.04) – (+0.04) in

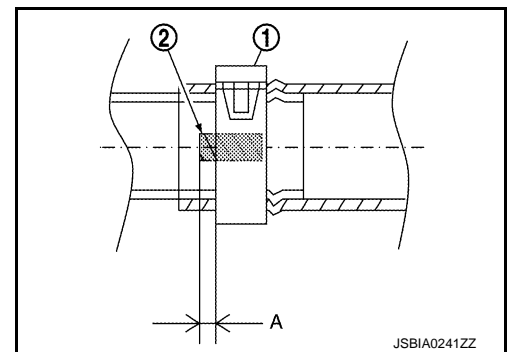

Without paint mark

RADIATOR

< REMOVAL AND INSTALLATION >

- To install hose clamps (1), check that the dimension (A) from the end of the hose clamp on the radiator hose to the hose clamp is within the reference value.

Dimension "A"

1 – 5 mm (0.04 - 0.19 in)

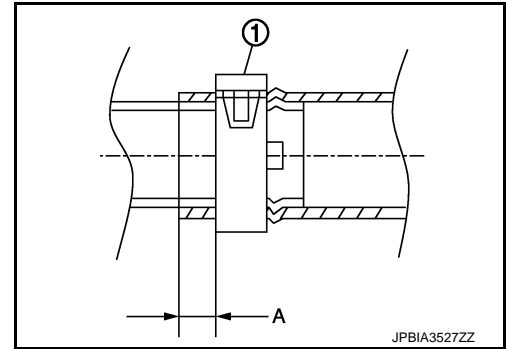

Inspection

INFOID:000000007542460

INSPECTION AFTER INSTALLATION

- Check for leakage of engine coolant using the radiator cap tester adapter (commercial service tool) and the radiator cap tester (commercial service tool). Refer to [CO-11, "Inspection"](#).
- Start and warm up the engine. Visually check that there is no leakage of engine coolant and CVT fluid.

COOLING FAN

< REMOVAL AND INSTALLATION >

COOLING FAN

Exploded View

INFOID:000000007542461

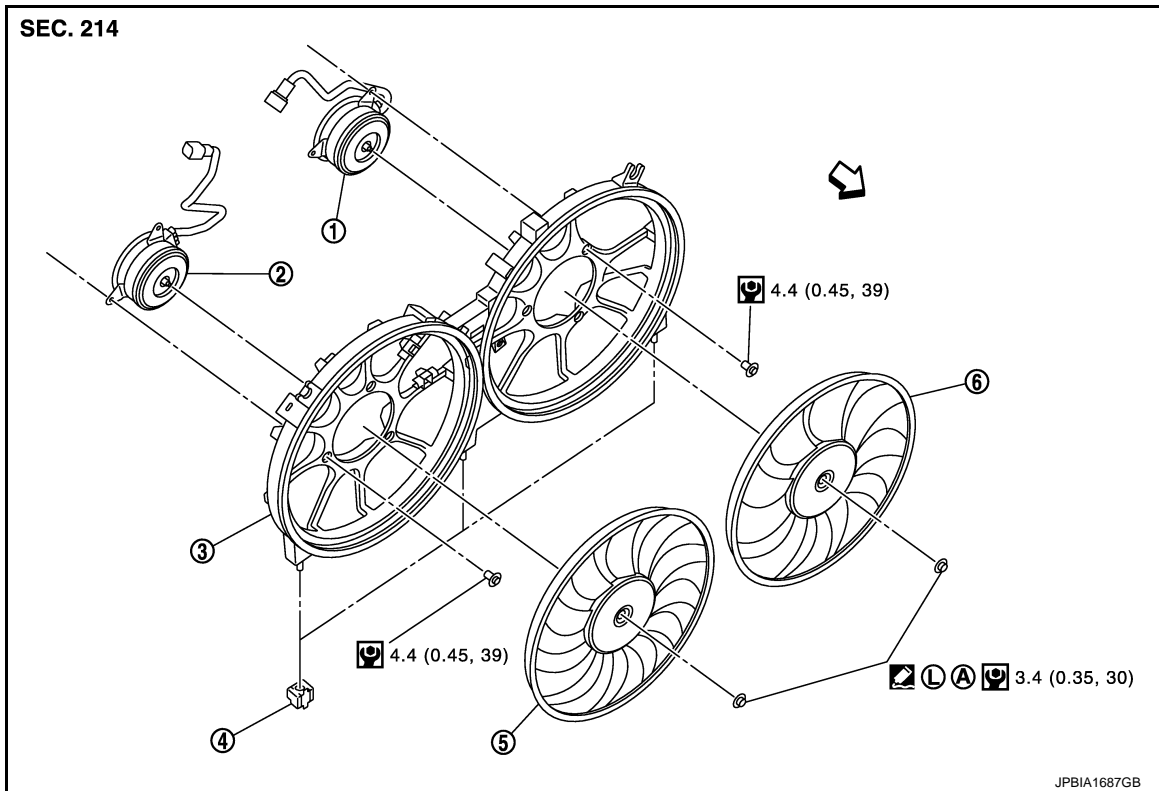

- | | | |
|--------------------|---------------------|---------------------|
| 1. Fan motor (LH) | 2. Fan motor (RH) | 3. Fan shroud |
| 4. Mounting rubber | 5. Cooling fan (RH) | 6. Cooling fan (LH) |

A. Apply on fan motor shaft

← : Vehicle front

(L) : Apply genuine high strength thread locking sealant or equivalent.

: N·m (kg·m, in·lb)

Removal and Installation

INFOID:000000007542462

REMOVAL

- Remove the following parts.
 - Engine under cover
 - Air duct (inlet): Refer to [EM-31, "Exploded View"](#).
 - Oil level gauge: Refer to [EM-111, "Exploded View"](#).
 - Battery and battery tray: Refer to [PG-113, "Removal and Installation"](#).
- Drain engine coolant from radiator. Refer to [CO-11, "Draining"](#).
CAUTION:
 - Perform this step engine is cold.
 - Never spill engine coolant on drive belt.
- Remove radiator cap adapter and each radiator hoses (upper) and radiator pipe (upper) assembly. Refer to [CO-16, "Exploded View"](#).
- Disconnect harness connector from fan motors (RH and LH), and move harness to aside.
- Disconnect harness connector from crash zone sensor, and move harness to aside. Refer to [SR-21, "Exploded View"](#).
- Remove battery tray bracket mounting bolts, and move battery tray bracket to aside.

COOLING FAN

< REMOVAL AND INSTALLATION >

7. Remove cooling fan assembly.

CAUTION:

Be careful not to damage or scratch on radiator core.

INSTALLATION

Note the following, and install in the reverse order of removal.

CAUTION:

Only use genuine parts for cooling fan mounting bolt and observe the specified torque (to prevent radiator from being damaged).

NOTE:

Cooling fans are controlled by ECM. For details, refer to [EC-74, "System Diagram"](#).

Disassembly and Assembly

INFOID:000000007542463

DISASSEMBLY

1. Remove cooling fan mounting nuts, and then remove the cooling fans (RH and LH).
2. Remove fan motors (RH and LH).

ASSEMBLY

Note the following, and assemble in the reverse order of disassembly.

CAUTION:

RH and LH cooling fans are different. Be careful not to misassemble them.

- Install each fan in the following position.

Right side : 11 blades

Left side : 9 blades

- Secure the harness tightly to the fan shroud to prevent the fan rotation area from being loose.

Inspection

INFOID:000000007542464

INSPECTION AFTER DISASSEMBLY

Cooling Fan

Inspect cooling fan for crack or unusual bend.

- If anything is found, replace cooling fan.

WATER PUMP

< REMOVAL AND INSTALLATION >

WATER PUMP

Exploded View

INFOID:000000007542465

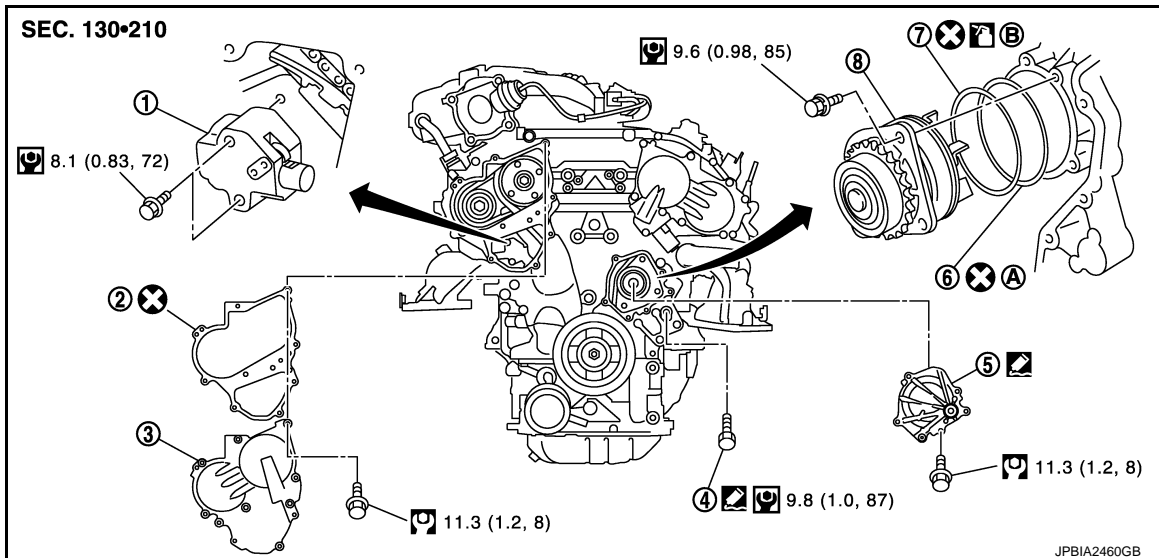

- | | | |
|-------------------------------------|---|--|
| 1. Timing chain tensioner (primary) | 2. Valve timing control cover gasket (bank 1) | 3. Valve timing control cover (bank 1) |
| 4. Water drain plug (front) | 5. Water pump cover | 6. O-ring |
| 7. O-ring | 8. Water pump | |
| A. Apply engine coolant | B. Identify with white mark | |

⊗ : Always replace after every disassembly.

Ⓜ : N·m (kg-m, ft-lb)

Ⓜ : N·m (kg-m, in-lb)

🛢 : Should be lubricated with oil.

🖌 : Sealing point

Removal and Installation

INFOID:000000007542466

CAUTION:

- When removing water pump assembly, be careful not to get engine coolant on drive belt.
- Water pump cannot be disassembled and should be replaced as a unit.
- After installing water pump, connect hose and clamp securely, then check for leakage using the radiator cap tester (commercial service tool) and the radiator cap tester adapter (commercial service tool).

REMOVAL

1. Remove the following parts.
 - Air duct (inlet): Refer to [EM-31, "Exploded View"](#).
 - Engine cover: Refer to [EM-29, "Exploded View"](#).
 - Engine under cover
 - Front road wheel and tire
 - Splash guard (RH): Refer to [EXT-23, "FENDER PROTECTOR : Exploded View"](#).
2. Drain engine coolant from radiator. Refer to [CO-11, "Draining"](#).
CAUTION:
 - Perform this step when the engine is cold.
 - Never spill engine coolant on drive belt.
3. Remove drive belt. Refer to [EM-17, "Removal and Installation"](#).
4. Remove idler pulleys. Refer to [EM-30, "Exploded View"](#).

WATER PUMP

< REMOVAL AND INSTALLATION >

5. Remove reservoir tank of radiator. Refer to [CO-16, "Exploded View"](#).
6. Remove reservoir tank of power steering oil pump with piping connected, and move it to aside. Refer to [ST-62, "Exploded View"](#).
7. Support oil pan (lower) bottom with transmission jack.
8. Remove engine mounting insulator (RH), engine mounting bracket (RH) and upper torque rod. Refer to [EM-72, "2WD : Exploded View"](#) (2WD models) or [EM-81, "AWD : Exploded View"](#) (AWD models).
9. Remove water drain plug (front) on water pump side of cylinder block to drain engine coolant from engine inside.
10. Remove valve timing control cover (bank 1) and water pump cover from front timing chain case.
 - Use the seal cutter [SST: KV10111100 (J-37228)] to cut liquid gasket for removal.
11. Remove timing chain tensioner (primary) as follows:

- a. Remove lower mounting bolt (1).

CAUTION:

Be careful not to drop mounting bolt inside timing chain case.

- b. Loosen upper mounting bolt (2) slowly, and then turn chain tensioner (primary) (3) on the mounting bolt so that plunger (4) is fully expanded.

NOTE:

Even if plunger is fully expanded, it is not dropped from the body of timing chain tensioner (primary).

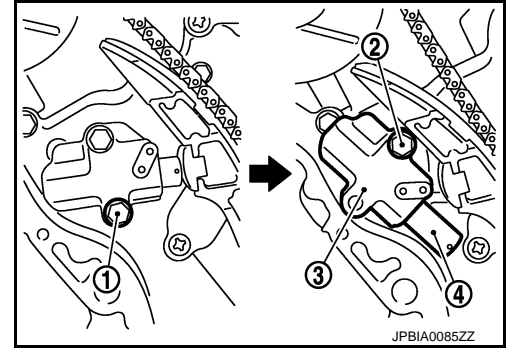

- c. Turn crankshaft pulley clockwise so that timing chain on the timing chain tensioner (primary) side is loose.

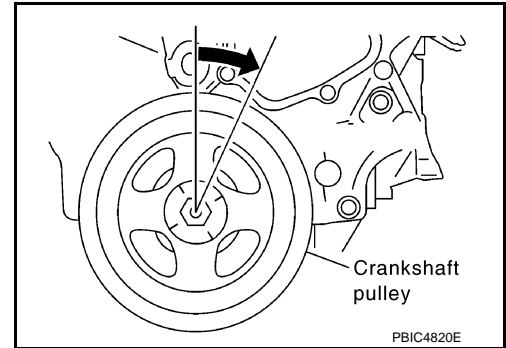

- d. Remove upper mounting bolt, and then remove timing chain tensioner (primary).

CAUTION:

Be careful not to drop mounting bolt inside timing chain case.

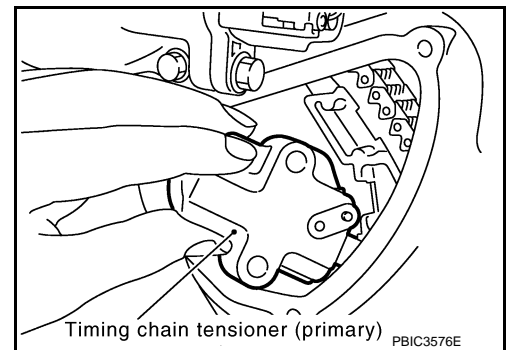

12. Remove water pump as follows:

WATER PUMP

< REMOVAL AND INSTALLATION >

- a. Remove three water pump mounting bolts. Secure a gap between water pump gear and timing chain, by turning crankshaft pulley counterclockwise until timing chain looseness on water pump sprocket becomes maximum.

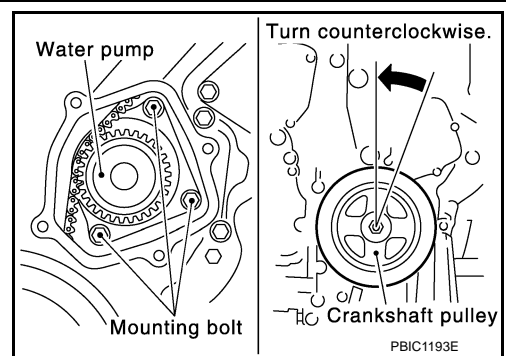

- b. Screw M8 bolts [pitch: 1.25 mm (0.0492 in) length: approximately 50 mm (1.97 in)] into water pumps upper and lower mounting bolt holes until they reach timing chain case. Then, alternately tighten each bolt for a half turn, and pull out water pump.

CAUTION:

- Pull straight out while preventing vane from contacting socket in installation area.
- Remove water pump without causing sprocket to contact timing chain.

- c. Remove M8 bolts and O-rings from water pump.

CAUTION:

Never disassemble water pump.

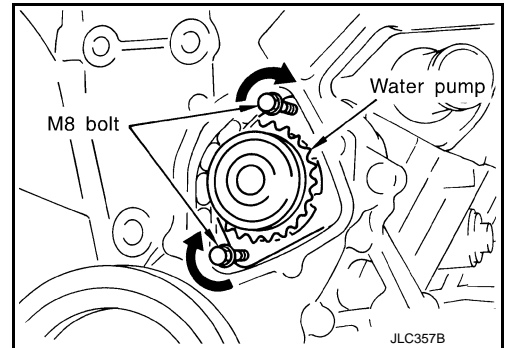

INSTALLATION

CAUTION:

Do not reuse O-rings.

1. Install new O-rings to water pump.

CAUTION:

Do not reuse O-rings.

- Apply engine oil and engine coolant to O-rings as shown in the figure.
- Locate O-ring with white paint mark to engine front side.

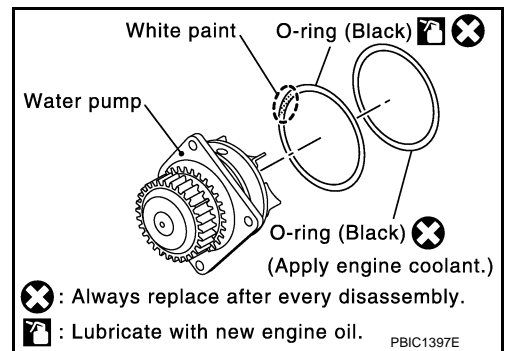

2. Install water pump.

CAUTION:

Never allow cylinder block to nip O-rings when installing water pump.

- Check that timing chain and water pump sprocket are engaged.
- Insert water pump by tightening mounting bolts alternately and evenly.

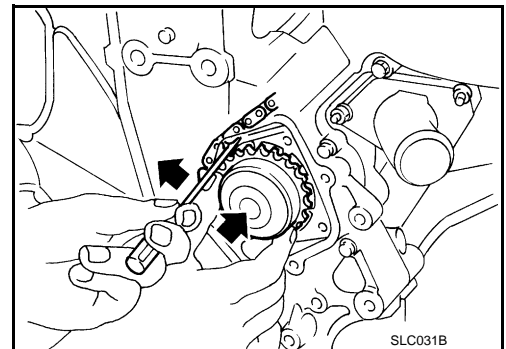

3. Install timing chain tensioner (primary) as follows:

WATER PUMP

< REMOVAL AND INSTALLATION >

- a. Turn crankshaft pulley clockwise so that timing chain on the timing chain tensioner (primary) side is loose.

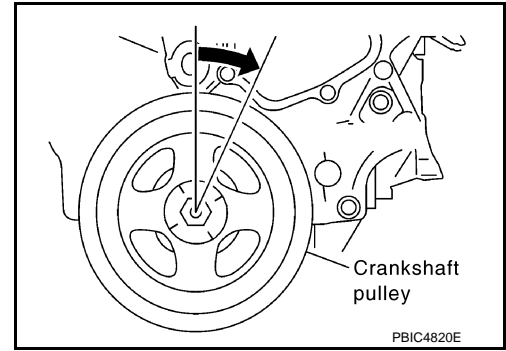

- b. Pull plunger stopper tab (A) up (or turn lever downward) so as to remove plunger stopper tab from the ratchet of plunger (D).

NOTE:

Plunger stopper tab and lever (C) are synchronized.

- c. Push plunger into the inside of tensioner body.
 d. Hold plunger in the fully compressed position by engaging plunger stopper tab with the tip of ratchet.
 e. To secure lever, insert stopper pin (E) through hole of lever into tensioner body hole (B).
 • The lever parts and the tab are synchronized. Therefore, the plunger will be secured under this condition.

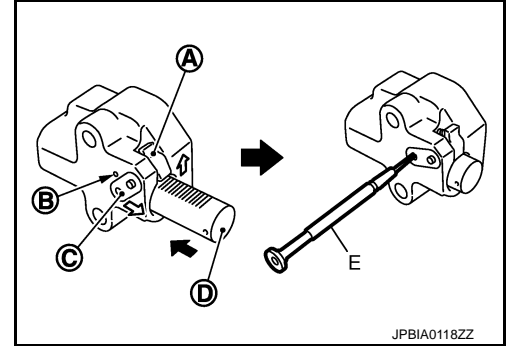

NOTE:

Figure shows the example of 1.2 mm (0.047 in) diameter thin screwdriver being used as the stopper pin.

- f. Install timing chain tensioner (primary).
 • Remove dust and foreign material completely from backside of timing chain tensioner (primary) and from installation area of rear timing chain case.
 g. Remove stopper pin (A).

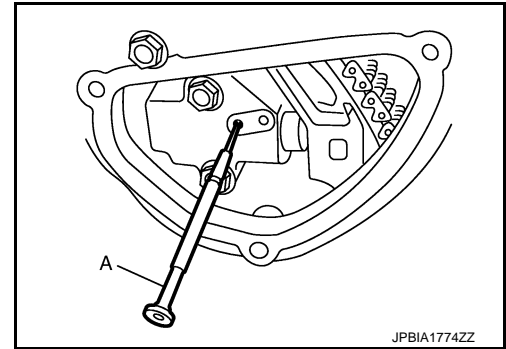

- h. Check again that timing chain and water pump sprocket are engaged.
 4. Install valve timing control cover (bank 1) and water pump cover as follows:
 a. Before installing, remove all traces of old liquid gasket from mating surface of water pump cover using scraper. Also remove traces of old liquid gasket from the mating surface of front timing chain case.

- b. Apply a continuous bead of liquid gasket with the tube presser (commercial service tool) to mating surface of water pump cover (1).

a : $\phi 2.3 - 3.3$ mm (0.091 - 0.130 in)

Use Genuine RTV Silicone Sealant or equivalent. Refer to [GI-22, "Recommended Chemical Products and Sealants"](#).

CAUTION:

Attaching should be done within 5 minutes after coating.

- c. Tighten mounting bolts.

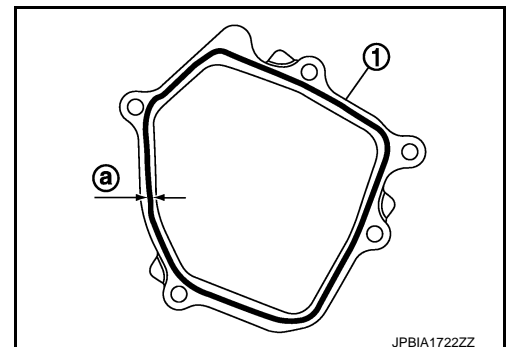

WATER PUMP

< REMOVAL AND INSTALLATION >

5. Install water drain plug (front) on water pump side of cylinder block.
 - Apply liquid gasket to the thread of water drain plug (front).
Use Genuine RTV Silicone Sealant or equivalent. Refer to [GI-22. "Recommended Chemical Products and Sealants"](#).
6. Install in the reverse order of removal after this step.
 - **After starting engine, let idle for three minutes, then rev engine up to 3,000 rpm under no load to purge air from the high-pressure chamber of chain tensioner. Engine may produce a rattling noise. This indicates that air still remains in the chamber and is not a matter of concern.**

Inspection

INFOID:000000007542467

INSPECTION AFTER REMOVAL

- Check for badly rusted or corroded water pump body assembly.
- Check for rough operation due to excessive end play.
- If anything is found, replace water pump.

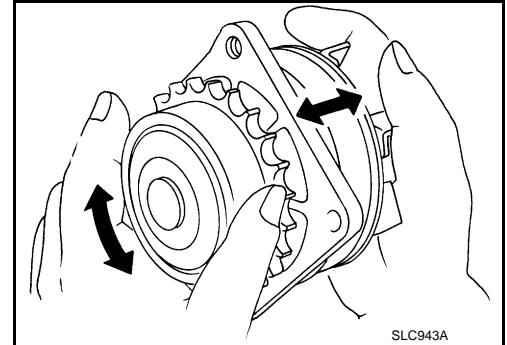

INSPECTION AFTER INSTALLATION

- Check for leakage of engine coolant using the radiator cap tester adapter (commercial service tool) and the radiator cap tester (commercial service tool). Refer to [CO-11. "Inspection"](#).
- Start and warm up the engine. Visually check that there is no leakage of engine coolant.

WATER INLET AND THERMOSTAT ASSEMBLY

< REMOVAL AND INSTALLATION >

Inspection

INFOID:000000007542470

INSPECTION AFTER REMOVAL

1. Check valve seating condition at ordinary room temperatures. It should seat tightly.
2. Check valve operation.

Thermostat (Standard) : Refer to [CO-32, "Thermostat"](#).

- If the malfunctioning condition, when valve seating at ordinary room temperature, or measured values are out of the standard, replace water inlet and thermostat assembly.

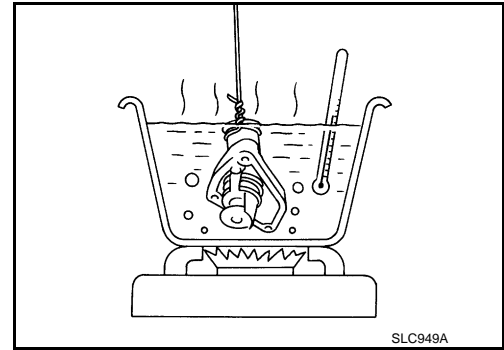

INSPECTION AFTER INSTALLATION

- Check for leakage of engine coolant using the radiator cap tester adapter (commercial service tool) and the radiator cap tester (commercial service tool). Refer to [CO-11, "Inspection"](#).
- Start and warm up the engine. Visually check that there is no leakage of engine coolant.

A
CO
C
D
E
F
G
H
I
J
K
L
M
N
O
P

WATER OUTLET AND WATER PIPING

< REMOVAL AND INSTALLATION >

WATER OUTLET AND WATER PIPING

Exploded View

INFOID:000000007542471

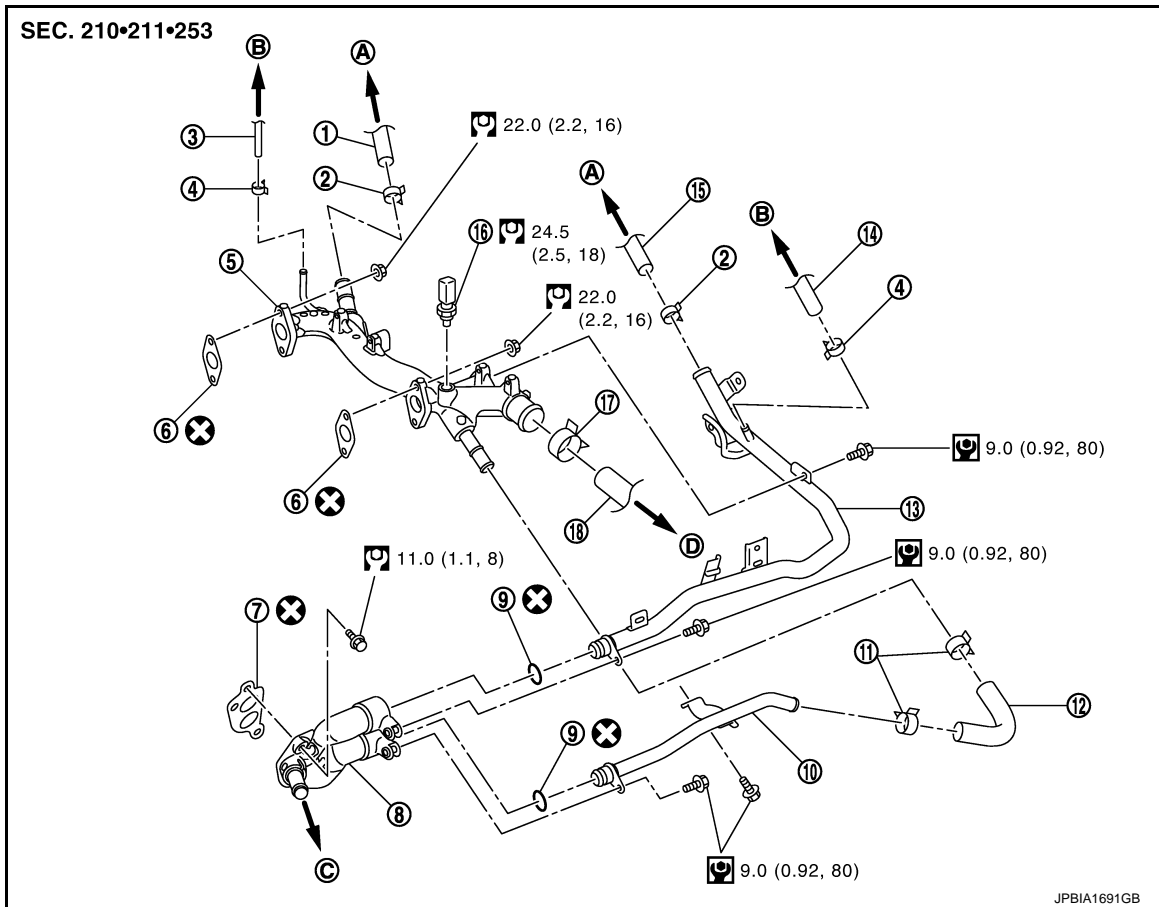

- | | | |
|---------------------------------------|--|---------------------------|
| 1. Heater hose | 2. Clamp | 3. Water hose |
| 4. Clamp | 5. Water outlet | 6. Gasket |
| 7. Gasket | 8. Water connector | 9. O-ring |
| 10. Water bypass pipe | 11. Clamp | 12. Water hose |
| 13. Heater pipe | 14. Water hose | 15. Heater hose |
| 16. Engine coolant temperature sensor | 17. Clamp | 18. Radiator hose (upper) |
| A. To heater core | B. To electric throttle control actuator | C. To oil cooler |
| D. To radiator | | |

⊗ : Always replace after every disassembly.

⊙ : N·m (kg·m, ft·lb)

⊙ : N·m (kg·m, in·lb)

Removal and Installation

INFOID:000000007542472

REMOVAL

1. Remove air duct (inlet), radiator core support covers (RH and LH), air cleaner cases (upper and lower) with mass air flow sensor and air duct assembly. Refer to [EM-31. "Exploded View"](#).
2. Remove engine cover. Refer to [EM-29. "Exploded View"](#).
3. Drain engine coolant from radiator drain plug at the bottom of radiator, and from water drain plug at the front of cylinder block. Refer to [CO-11. "Draining"](#) and [EM-90. "Setting"](#).

CAUTION:

WATER OUTLET AND WATER PIPING

< REMOVAL AND INSTALLATION >

- Perform this step when the engine is cold.
- Never spill engine coolant on drive belt.

4. Remove battery and battery tray. Refer to [PG-113, "Removal and Installation"](#).
5. Remove CVT fluid charging pipe and CVT fluid level gauge. Refer to [TM-162, "Exploded View"](#).
6. Move CVT control cable aside. Refer to [TM-153, "Exploded View"](#).
7. Remove vacuum tube (front) mounting bolt from water outlet. Refer to [EM-72, "2WD : Exploded View"](#) (2WD models) or [EM-81, "AWD : Exploded View"](#) (AWD models).
8. Remove radiator hose (upper) from water outlet.
9. Remove water hoses and heater hoses.
10. Disconnect harness connectors, and move harness to aside.
11. Remove engine coolant temperature sensor if necessary.
CAUTION:
Be careful not to damage engine coolant temperature sensor.
12. Remove water outlet, heater pipe, water bypass pipe and water connector.

INSTALLATION

CAUTION:

Do not reuse O-rings.

Note the following, and install in the reverse order of removal.

- Securely insert each hose, and install clamp at a position where it does not interfere with the pipe bulge.
- When inserting water bypass pipe and heater pipe into water connector, apply neutral detergent to O-ring.

Inspection

INFOID:000000007542473

INSPECTION AFTER INSTALLATION

- Check for leakage of engine coolant using the radiator cap tester adapter (commercial service tool) and the radiator cap tester (commercial service tool). Refer to [CO-11, "Inspection"](#).
- Start and warm up the engine. Visually check that there is no leakage of engine coolant.

SERVICE DATA AND SPECIFICATIONS (SDS)

< SERVICE DATA AND SPECIFICATIONS (SDS)

SERVICE DATA AND SPECIFICATIONS (SDS)

SERVICE DATA AND SPECIFICATIONS (SDS)

Periodical Maintenance Specification

INFOID:000000007542474

ENGINE COOLANT CAPACITY (APPROXIMATE)

Unit: ℓ (US qt, Imp qt)

Engine coolant capacity (With reservoir tank at "MAX" level)	9.0 (9-1/2, 7-7/8)
Reservoir tank	0.8 (7/8, 3/4)

Radiator

INFOID:000000007542475

Unit: kPa (kg/cm², psi)

Cap relief pressure	Standard	122.3 - 151.7 (1.2 - 1.5, 17.7 - 22.0)
	Limit	108 (1.1, 15.6)
Leakage test pressure		156 (1.59, 22.6)

Thermostat

INFOID:000000007542476

Standard

Valve opening temperature	80.5 - 83.5°C (177 - 182°F)
Maximum valve lift	8.6 mm/95°C (0.339 in/203°F)
Valve closing temperature	77°C (171°F)