

SECTION **FSU**
FRONT SUSPENSION

A
B
C
D

FSU

CONTENTS

SYMPTOM DIAGNOSIS	2	REMOVAL AND INSTALLATION	9	F
NOISE, VIBRATION AND HARSHNESS (NVH) TROUBLESHOOTING	2	FRONT COIL SPRING AND STRUT	9	G
NVH Troubleshooting Chart	2	Exploded View	9	
PRECAUTION	3	Removal and Installation	9	
PRECAUTIONS	3	Disassembly and Assembly	10	H
FOR USA AND CANADA	3	Inspection	11	
FOR USA AND CANADA : Precaution for Supplemental Restraint System (SRS) "AIR BAG" and "SEAT BELT PRE-TENSIONER"	3	Disposal	11	
FOR MEXICO	3	TRANSVERSE LINK	12	I
FOR MEXICO : Precaution for Supplemental Restraint System (SRS) "AIR BAG" and "SEAT BELT PRE-TENSIONER"	3	Exploded View	12	
Precaution for Procedure without Cowl Top Cover.....	4	Removal and Installation	12	
Precautions for Suspension	4	Inspection	12	J
Precautions for Removing of Battery Terminal	4	FRONT STABILIZER	14	
PREPARATION	5	Exploded View	14	
PREPARATION	5	Removal and Installation	14	K
Special Service Tool	5	Inspection	15	
Commercial Service Tool	5	UNIT REMOVAL AND INSTALLATION	16	L
PERIODIC MAINTENANCE	6	FRONT SUSPENSION MEMBER	16	
FRONT SUSPENSION ASSEMBLY	6	Exploded View	16	M
Inspection	6	Removal and Installation	16	
WHEEL ALIGNMENT	7	Inspection	16	
Inspection	7	SERVICE DATA AND SPECIFICATIONS (SDS)	18	N
Adjustment	7	SERVICE DATA AND SPECIFICATIONS (SDS)	18	
		Wheel Alignment	18	O
		Ball Joint	19	
		Wheelarch Height	19	P

NOISE, VIBRATION AND HARSHNESS (NVH) TROUBLESHOOTING

< SYMPTOM DIAGNOSIS >

SYMPTOM DIAGNOSIS

NOISE, VIBRATION AND HARSHNESS (NVH) TROUBLESHOOTING

NVH Troubleshooting Chart

INFOID:000000009721391

Use chart below to find the cause of the symptom. If necessary, repair or replace these parts.

Symptom		Possible cause and SUSPECTED PARTS																Reference
		Improper installation, looseness	Shock absorber deformation, damage or deflection	Bushing or mounting deterioration	Parts interference	Spring fatigue	Suspension looseness	Incorrect wheel alignment	Stabilizer bar fatigue	PROPELLER SHAFT (AWD)	DIFFERENTIAL (AWD)	FRONT AXLE AND FRONT SUSPENSION	TIRE	ROAD WHEEL	DRIVE SHAFT	BRAKE	STEERING	
FRONT SUSPENSION	Noise	x	x	x	x	x	x			x	x	x	x	x	x	x	x	FSU-9, FSU-12, FSU-14, FSU-16
	Shake	x	x	x	x		x			x		x	x	x	x			FSU-11
	Vibration	x	x	x	x	x				x		x	x		x			—
	Shimmy	x	x	x	x			x				x	x	x		x		—
	Judder	x	x	x								x	x	x		x		FSU-11
	Poor quality ride or handling	x	x	x	x	x		x	x			x	x	x				FSU-9, FSU-12, FSU-14, FSU-16
																		FSU-7
																		FSU-15
																		NVH in DLN section
																		NVH in DLN section
																		NVH in FAX and FSU sections
																		NVH in WT section
																		NVH in WT section
																		NVH in FAX section
																		NVH in BR section
																		NVH in ST section

x: Applicable

PRECAUTIONS

< PRECAUTION >

PRECAUTION

PRECAUTIONS

FOR USA AND CANADA

FOR USA AND CANADA : Precaution for Supplemental Restraint System (SRS) "AIR BAG" and "SEAT BELT PRE-TENSIONER"

INFOID:000000009721392

The Supplemental Restraint System such as "AIR BAG" and "SEAT BELT PRE-TENSIONER", used along with a front seat belt, helps to reduce the risk or severity of injury to the driver and front passenger for certain types of collision. This system includes seat belt switch inputs and dual stage front air bag modules. The SRS system uses the seat belt switches to determine the front air bag deployment, and may only deploy one front air bag, depending on the severity of a collision and whether the front occupants are belted or unbelted. Information necessary to service the system safely is included in the "SRS AIR BAG" and "SEAT BELT" of this Service Manual.

WARNING:

Always observe the following items for preventing accidental activation.

- To avoid rendering the SRS inoperative, which could increase the risk of personal injury or death in the event of a collision that would result in air bag inflation, all maintenance must be performed by an authorized NISSAN/INFINITI dealer.
- Improper maintenance, including incorrect removal and installation of the SRS, can lead to personal injury caused by unintentional activation of the system. For removal of Spiral Cable and Air Bag Module, see "SRS AIR BAG".
- Never use electrical test equipment on any circuit related to the SRS unless instructed to in this Service Manual. SRS wiring harnesses can be identified by yellow and/or orange harnesses or harness connectors.

PRECAUTIONS WHEN USING POWER TOOLS (AIR OR ELECTRIC) AND HAMMERS

WARNING:

Always observe the following items for preventing accidental activation.

- When working near the Air Bag Diagnosis Sensor Unit or other Air Bag System sensors with the ignition ON or engine running, never use air or electric power tools or strike near the sensor(s) with a hammer. Heavy vibration could activate the sensor(s) and deploy the air bag(s), possibly causing serious injury.
- When using air or electric power tools or hammers, always switch the ignition OFF, disconnect the battery, and wait at least 3 minutes before performing any service.

FOR MEXICO

FOR MEXICO : Precaution for Supplemental Restraint System (SRS) "AIR BAG" and "SEAT BELT PRE-TENSIONER"

INFOID:000000009721395

The Supplemental Restraint System such as "AIR BAG" and "SEAT BELT PRE-TENSIONER", used along with a front seat belt, helps to reduce the risk or severity of injury to the driver and front passenger for certain types of collision. Information necessary to service the system safely is included in the "SRS AIR BAG" and "SEAT BELT" of this Service Manual.

WARNING:

Always observe the following items for preventing accidental activation.

- To avoid rendering the SRS inoperative, which could increase the risk of personal injury or death in the event of a collision that would result in air bag inflation, all maintenance must be performed by an authorized NISSAN/INFINITI dealer.
- Improper maintenance, including incorrect removal and installation of the SRS, can lead to personal injury caused by unintentional activation of the system. For removal of Spiral Cable and Air Bag Module, see "SRS AIR BAG".
- Never use electrical test equipment on any circuit related to the SRS unless instructed to in this Service Manual. SRS wiring harnesses can be identified by yellow and/or orange harnesses or harness connectors.

PRECAUTIONS WHEN USING POWER TOOLS (AIR OR ELECTRIC) AND HAMMERS

WARNING:

A

B

C

D

FSU

F

G

H

I

J

K

L

M

N

O

P

PRECAUTIONS

< PRECAUTION >

Always observe the following items for preventing accidental activation.

- When working near the Air Bag Diagnosis Sensor Unit or other Air Bag System sensors with the ignition ON or engine running, never use air or electric power tools or strike near the sensor(s) with a hammer. Heavy vibration could activate the sensor(s) and deploy the air bag(s), possibly causing serious injury.
- When using air or electric power tools or hammers, always switch the ignition OFF, disconnect the battery, and wait at least 3 minutes before performing any service.

Precaution for Procedure without Cowl Top Cover

INFOID:000000009721393

When performing the procedure after removing cowl top cover, cover the lower end of windshield with urethane, etc to prevent damage to windshield.

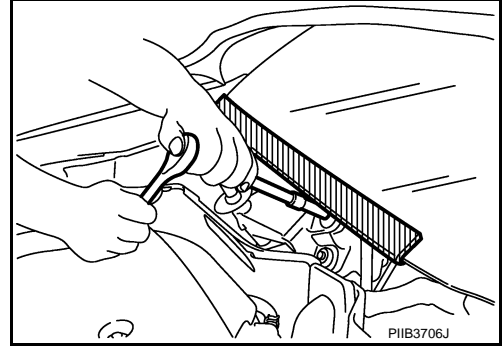

Precautions for Suspension

INFOID:000000009721394

- When installing rubber bushings, the final tightening must be carried out under unladen conditions with tires on ground. Spilled oil might shorten the life of rubber bushings. Be sure to wipe off any spilled oil.
- Unladen conditions mean that fuel, engine coolant and lubricant are full. Spare tire, jack, hand tools and mats are in designated positions.
- After servicing suspension parts, be sure to check wheel alignment.
- Self-lock nuts are not reusable. Always use new ones when installing. Since new self-lock nuts are pre-oiled, tighten as they are.

Precautions for Removing of Battery Terminal

INFOID:00000000973192

- When removing the 12V battery terminal, turn OFF the ignition switch and wait at least 30 seconds.

NOTE:

ECU may be active for several tens of seconds after the ignition switch is turned OFF. If the battery terminal is removed before ECU stops, then a DTC detection error or ECU data corruption may occur.

- For vehicles with the 2-batteries, be sure to connect the main battery and the sub battery before turning ON the ignition switch.

NOTE:

If the ignition switch is turned ON with any one of the terminals of main battery and sub battery disconnected, then DTC may be detected.

- After installing the 12V battery, always check "Self Diagnosis Result" of all ECUs and erase DTC.

NOTE:

The removal of 12V battery may cause a DTC detection error.

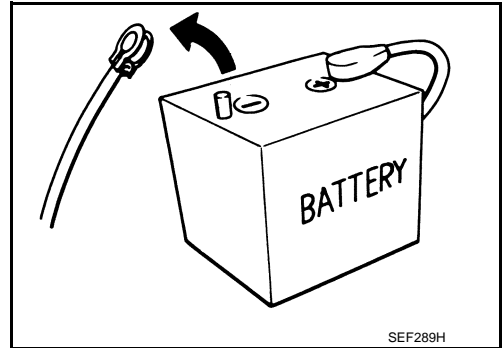

PREPARATION

< PREPARATION >

PREPARATION

PREPARATION

Special Service Tool

INFOID:000000009721398

The actual shapes of Kent-More tools may differ from those of special service tools illustrated here.

Tool number (Kent-More No.) Tool name	Description
ST35652000 (—) Strut attachment	Disassembling and assembling strut

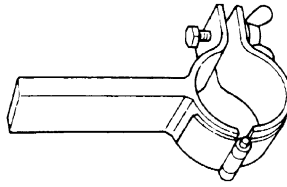

ZZA0807D

Commercial Service Tool

INFOID:000000009721399

Tool name	Description
Spring compressor	Removing and installing coil spring
Power tool	Loosening bolts and nuts

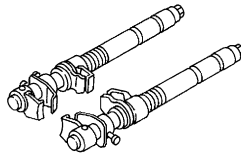

S-NT717

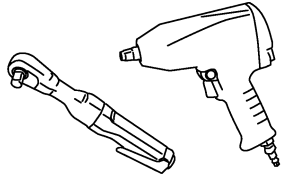

PBIC0190E

A
B
C
D
FSU
F
G
H
I
J
K
L
M
N
O
P

FRONT SUSPENSION ASSEMBLY

< PERIODIC MAINTENANCE >

PERIODIC MAINTENANCE

FRONT SUSPENSION ASSEMBLY

Inspection

INFOID:000000009721400

COMPONENT PART

Check the mounting conditions (looseness, backlash) of each component and component conditions (wear, damage) are normal.

Ball Joint Axial End Play

1. Set front wheels in a straight-ahead position.
2. Move axle side of transverse link in the axial direction by hand. Check there is no end play.

Axial end play : Refer to [FSU-19. "Ball Joint"](#).

CAUTION:

- Never depress brake pedal when measuring.
- Never perform with tires on level ground.
- Be careful not to damage ball joint boot. Never damage the installation position by applying excessive force.

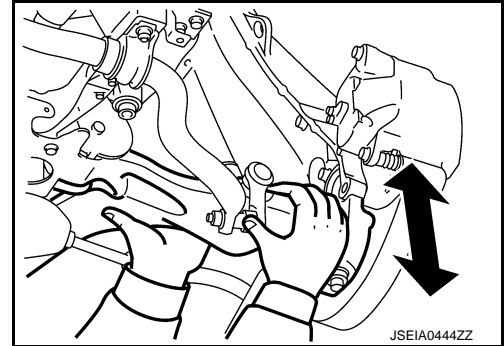

STRUT ASSEMBLY

Check for oil leakage, damage, and replace if necessary.

WHEEL ALIGNMENT

< PERIODIC MAINTENANCE >

WHEEL ALIGNMENT

Inspection

INFOID:000000009721401

DESCRIPTION

CAUTION:

- **Camber, caster, kingpin inclination angles cannot be adjusted.**
- **If camber, caster, or kingpin inclination angle is outside the standard, check front suspension parts for wear and damage. Replace suspect parts if a malfunction is detected.**
- **Kingpin inclination angle is reference value, no inspection is required.**

Measure wheel alignment under unladen conditions.

NOTE:

“Unladen conditions” means that fuel, engine coolant, and lubricant are full. Spare tire, jack, hand tools and mats are in designated positions.

PRELIMINARY CHECK

Check the following:

- Tires for improper air pressure and wear. Refer to [WT-52, "Tire Air Pressure"](#).
- Road wheels for runout.
- Wheel bearing axial end play. Refer to [FAX-9, "Inspection"](#) (2WD), [FAX-36, "Inspection"](#) (AWD).
- Transverse link ball joint axial end play. Refer to [FSU-6, "Inspection"](#).
- Strut operation.
- Each mounting part of axle and suspension for looseness and deformation.
- Each of suspension member, shock absorber, upper link and transverse link for cracks, deformation and other damage.
- Vehicle height (posture).

GENERAL INFORMATION AND RECOMMENDATIONS

- A four-wheel thrust alignment should be performed.
- This type of alignment is recommended for any NISSAN/INFINITI vehicle.
- The four-wheel “thrust” process helps ensure that the vehicle is properly aligned and the steering wheel is centered.
- The alignment rack itself should be capable of accepting any NISSAN/INFINITI vehicle.
- The rack should be checked to ensure that it is level.
- Make sure the machine is properly calibrated.
- Your alignment equipment should be regularly calibrated in order to give correct information.
- Check with the manufacturer of your specific equipment for their recommended Service/Calibration Schedule.

ALIGNMENT PROCESS

IMPORTANT:

Use only the alignment specifications listed in this Service Manual.

- When displaying the alignment settings, many alignment machines use “indicators”: (Green/red, plus or minus, Go/No Go). **Never use these indicators.**
- The alignment specifications programmed into your machine that operate these indicators may not be correct.
- This may result in an ERROR.
- Most camera-type alignment machines are equipped with both “Rolling Compensation” method and optional “Jacking Compensation” method to “compensate” the alignment targets or head units. “Rolling Compensation” is the preferred method.
- If using the “Rolling Compensation” method, after installing the alignment targets or head units, push or pull on the rear wheel to move the vehicle. **Do not push or pull on the vehicle body.**
- If using the “Jacking Compensation” method, after installing the alignment targets or head units, raise the vehicle and rotate the wheels 1/2 turn both ways.

NOTE:

- Do not use the “Rolling Compensation” method if you are using sensor-type alignment equipment.
- Follow all instructions for the alignment machine you're using for more information.

Adjustment

INFOID:000000009721402

TOE-IN

WHEEL ALIGNMENT

< PERIODIC MAINTENANCE >

- Loosen the steering outer socket, and then adjust the length using steering inner socket.

Toe-in : Refer to [FSU-18, "Wheel Alignment"](#).

CAUTION:

- Always evenly adjust both toe-in alternately and adjust the difference between the left and right to the standard.
- Always fix the steering inner socket when tightening the steering outer socket.
- After toe-in adjustment, adjust neutral position of steering angle sensor. Refer to [BRC-9, "ADJUSTMENT OF STEERING ANGLE SENSOR NEUTRAL POSITION : Special Repair Requirement"](#).

FRONT COIL SPRING AND STRUT

< REMOVAL AND INSTALLATION >

REMOVAL AND INSTALLATION

FRONT COIL SPRING AND STRUT

Exploded View

INFOID:000000009721403

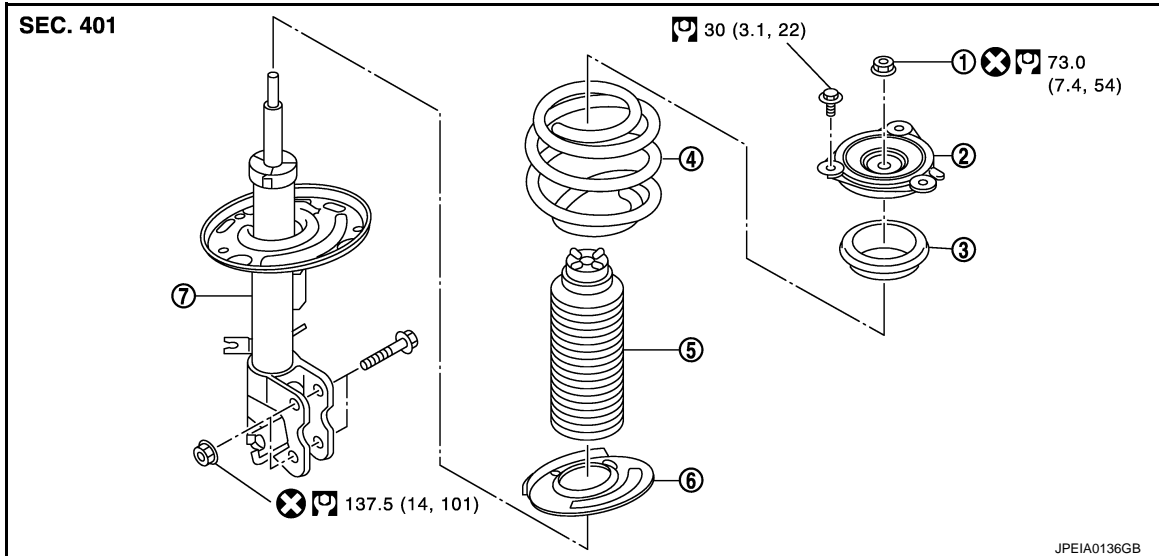

- | | | |
|------------------------|-----------------------------|---------------------------|
| 1. Piston rod lock nut | 2. Strut mounting insulator | 3. Strut mounting bearing |
| 4. Coil spring | 5. Bound bumper | 6. Lower rubber seat |
| 7. Strut | | |

Refer to [GI-4, "Components"](#) for symbols in the figure.

Removal and Installation

INFOID:000000009721404

REMOVAL

1. Remove tires with power tool.
2. Remove lock plate. Refer to [BR-22, "FRONT : Exploded View"](#).
3. Remove wheel sensor. Refer to [BRC-123, "FRONT WHEEL SENSOR : Exploded View"](#).
4. Remove stabilizer connecting rod from strut assembly. Refer to [FSU-14, "Exploded View"](#).
5. Remove strut assembly from steering knuckle.
6. Remove cowl top cover. Refer to [EXT-23, "Exploded View"](#).
7. Remove mounting bolts of strut mounting insulator with power tool, and then remove strut assembly.

INSTALLATION

Note the following, and install in the reverse order of removal.

- Become it in projection (A) an illustration to the body outside.

← : Vehicle front

- Perform final tightening of bolts and nuts, under unladen conditions with tires on level ground.

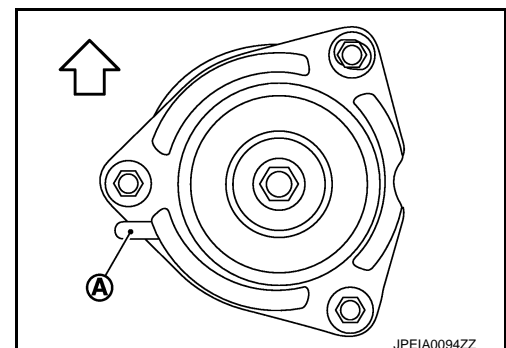

FRONT COIL SPRING AND STRUT

< REMOVAL AND INSTALLATION >

Disassembly and Assembly

INFOID:00000009721405

DISASSEMBLY

CAUTION:

Never damage strut assembly piston rod when removing components from strut assembly.

1. Install strut attachment (A) [SST: ST35652000 (—)] to strut assembly and secure it in a vise.

CAUTION:

When installing the strut attachment to strut assembly, wrap a shop cloth around strut to protect from damage.

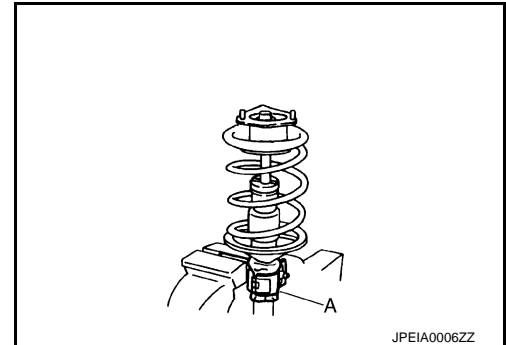

2. Using a spring compressor (A) (commercial service tool), compress coil spring between strut mounting bearing and lower rubber seat (on strut assembly) until coil spring with a spring compressor is free.

CAUTION:

Be sure a spring compressor is securely attached to coil spring. Compress coil spring.

3. Make sure coil spring with a spring compressor between strut mounting bearing and lower rubber seat (strut assembly) is free. And then remove piston rod lock nut while securing the piston rod tip so that piston rod does not turn.
4. Remove strut mounting insulator and strut mounting bearing, and bound bumper from strut.
5. After removing coil spring with a spring compressor (commercial service tool), then gradually release a spring compressor.

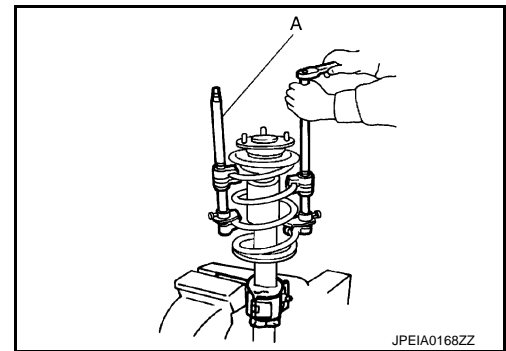

CAUTION:

Loosen while making sure coil spring attachment position does not move.

6. Remove lower rubber seat from strut.
7. Remove the strut attachment [SST: ST35652000 (—)] from strut.

ASSEMBLY

1. Install strut attachment [SST: ST35652000 (—)] to strut and secure it in a vise.

CAUTION:

When installing the strut attachment to strut assembly, wrap a shop cloth around strut to protect from damage.

2. Install lower rubber seat.
3. Install bound bumper onto strut mounting insulator.
4. Compress coil spring using a spring compressor (commercial service tool), and install it onto strut assembly.

CAUTION:

- Face tube side of coil spring (1) downward. Align the lower end (A) to lower rubber seat (2).
- Be sure a compressor is securely attached to coil spring. Compress coil spring.
- Set coil spring so that its paint marks are aligned with the positions of 1.25 turns and 2.25 turns from the bottom end of the coil spring.

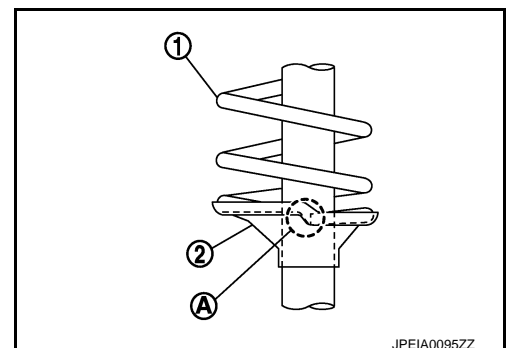

FRONT COIL SPRING AND STRUT

< REMOVAL AND INSTALLATION >

- Install strut mounting bearing and strut mounting insulator with bound bumper to strut.
 - Installation position of strut mounting insulator is shown in the figure.

A : Projection
 ⇐ : Vehicle front

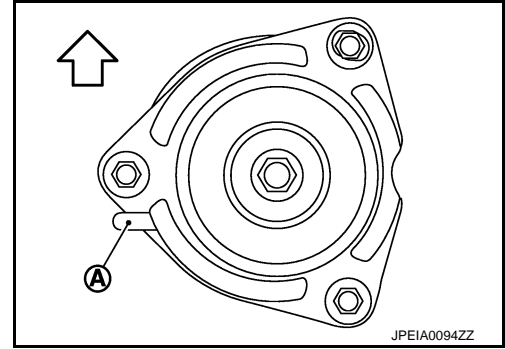

- Secure piston rod tip so that piston rod does not turn, then tighten piston rod lock nut with specified torque.

CAUTION:
Never reuse piston rod lock nut.

- Gradually release a spring compressor (commercial service tool), and remove coil spring.

CAUTION:
Loosen while making sure coil spring attachment position does not move.

- Remove the strut attachment [SST: ST35652000 (—)] from strut assembly.

Inspection

INFOID:000000009721406

INSPECTION AFTER DISASSEMBLY

Strut

Check the following items, and replace the parts if necessary.

- Strut for deformation, cracks or damage.
- Piston rod for damage, uneven wear or distortion.
- Oil leakage.

Strut Mounting Insulator and Rubber Parts Inspection

Check strut mounting insulator for cracks and rubber parts for wear. Replace it if necessary.

Coil Spring

Check coil spring for cracks, wear or damage. Replace it if necessary.

INSPECTION AFTER INSTALLATION

- Check wheel sensor harness for proper connector. Refer to [BRC-123, "FRONT WHEEL SENSOR : Exploded View"](#).
- Check wheel alignment. Refer to [FSU-7, "Inspection"](#).
- Adjust neutral position of steering angle sensor. Refer to [BRC-9, "ADJUSTMENT OF STEERING ANGLE SENSOR NEUTRAL POSITION : Special Repair Requirement"](#).

Disposal

INFOID:000000009721407

- Set strut assembly horizontally with the piston rod fully extended.
- Drill 2 – 3 mm (0.08 – 0.12 in) hole at the position (●) from top as shown in the figure to release gas gradually.

CAUTION:

- **Wear eye protection (safety glasses).**
- **Wear gloves.**
- **Be careful with metal chips or oil blown out by the compressed gas.**

NOTE:

- Drill vertically in this direction (⇐).
- Directly to the outer tube avoiding brackets.
- The gas is clear, colorless, odorless, and harmless.

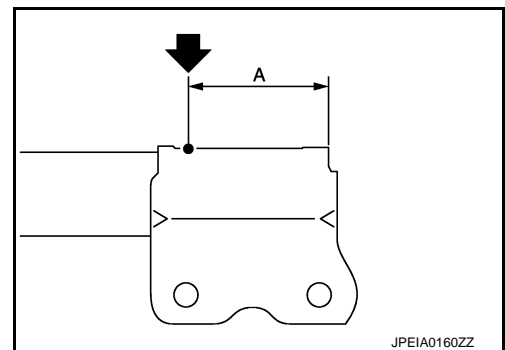

A : 20 – 30 mm (0.79 – 1.18 in)

- Position the drilled hole downward and drain oil by moving the piston rod several times.

CAUTION:
Dispose of drained oil according to the law and local regulations.

TRANSVERSE LINK

< REMOVAL AND INSTALLATION >

TRANSVERSE LINK

Exploded View

INFOID:000000009721408

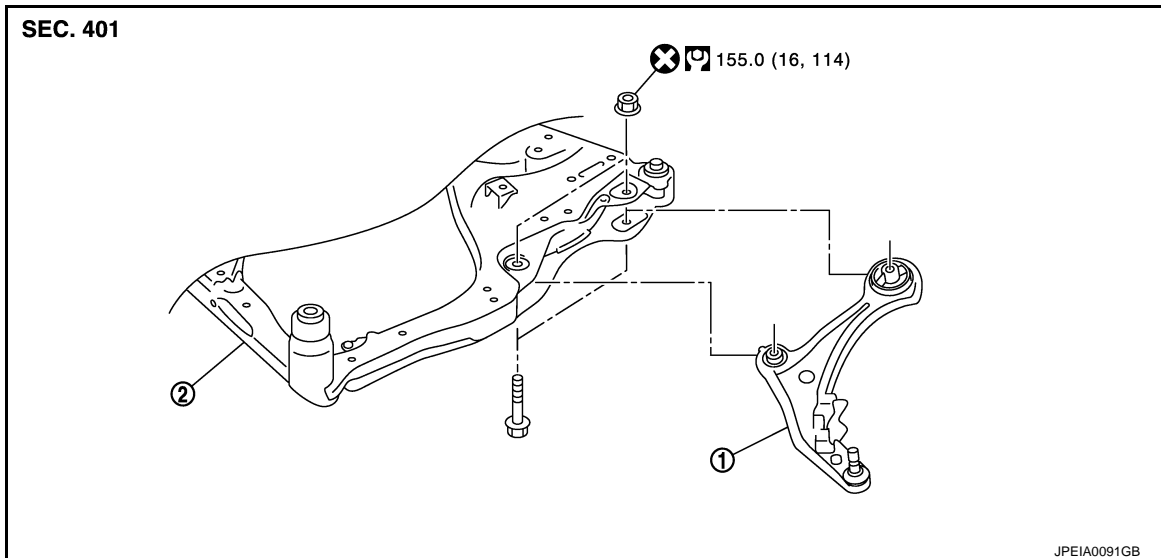

1. Transverse link
2. Front suspension member

Refer to [GI-4. "Components"](#) for symbols in the figure.

Removal and Installation

INFOID:000000009721409

REMOVAL

1. Remove tires with power tool.
2. Remove drive shaft of wheel side from wheel hub and bearing assembly. Refer to [FAX-18. "Exploded View"](#) (2WD), [FAX-45. "Exploded View"](#) (AWD).
3. Remove transverse link from steering knuckle.
4. Remove transverse link from suspension member.

INSTALLATION

Note the following, and install in the reverse order of removal.

- Perform final tightening of bolts and nuts at the front suspension member, under unladen conditions with tires on level ground.

Inspection

INFOID:000000009721410

INSPECTION AFTER REMOVAL

Appearance

Check the following items, and replace the part if necessary.

- Transverse link and bushing for deformation, cracks or damage.
- Ball joint boot for cracks or other damage, and also for grease leakage.

Ball Joint Inspection

Manually move ball stud to confirm it moves smoothly with no binding.

Swing Torque Inspection

1. Move ball stud at least ten times by hand to check for smooth movement.

TRANSVERSE LINK

< REMOVAL AND INSTALLATION >

- Hook a spring balance (A) at cotter pin mounting hole. Confirm spring balance measurement value is within specifications when ball stud begins moving.

Swing torque :Refer to [FSU-19, "Ball Joint"](#).

Spring balance measurement :Refer to [FSU-19, "Ball Joint"](#).

- If swing torque exceeds standard range, replace transverse link assembly.

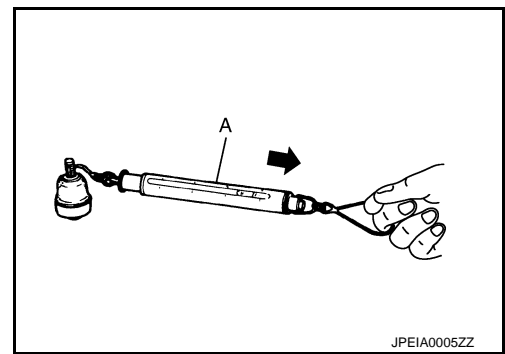

Axial End Play Inspection

- Move ball stud at least ten times by hand to check for smooth movement.
- Move tip of ball stud in axial direction to check for looseness.

Axial end play :Refer to [FSU-19, "Ball Joint"](#).

- If axial end play exceeds the standard value, replace transverse link assembly.

INSPECTION AFTER INSTALLATION

- Check wheel alignment. Refer to [FSU-7, "Inspection"](#).
- Adjust neutral position of steering angle sensor. Refer to [BRC-9, "ADJUSTMENT OF STEERING ANGLE SENSOR NEUTRAL POSITION : Special Repair Requirement"](#).

A
B
C
D

FSU

F

G

H

I

J

K

L

M

N

O

P

FRONT STABILIZER

< REMOVAL AND INSTALLATION >

FRONT STABILIZER

Exploded View

INFOID:000000009721411

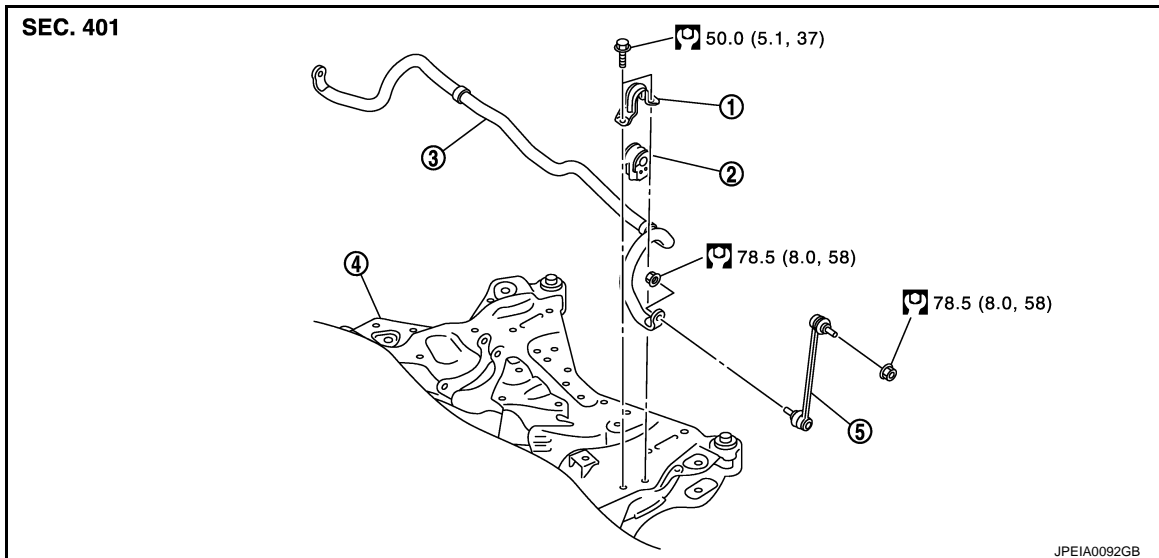

- | | | |
|----------------------------|------------------------------|-------------------|
| 1. Stabilizer clamp | 2. Stabilizer bushing | 3. Stabilizer bar |
| 4. Front suspension member | 5. Stabilizer connecting rod | |

Refer to [GI-4, "Components"](#) for symbols in the figure.

Removal and Installation

INFOID:000000009721412

REMOVAL

1. Remove tires power tool.
2. Remove front exhaust tube. Refer to [EX-5, "Exploded View"](#).
3. Remove rear propeller shaft from transfer. (AWD models) Refer to [DLN-85, "Exploded View"](#).
4. Remove lock plate. Refer to [BR-22, "FRONT : Exploded View"](#).
5. Remove wheel sensor harness from strut assembly. Refer to [BRC-123, "FRONT WHEEL SENSOR : Exploded View"](#).
6. Disconnect power steering solenoid valve harness connector. Refer to [ST-48, "Removal and Installation"](#).
7. Remove steering outer socket from steering knuckle. Refer to [ST-46, "Exploded View"](#).
8. Remove stabilizer connecting rod.
9. Remove mounting bolts (←) of stabilizer clamp, and then remove stabilizer clamp and stabilizer bushing from front suspension member.
10. Remove stabilizer bar.

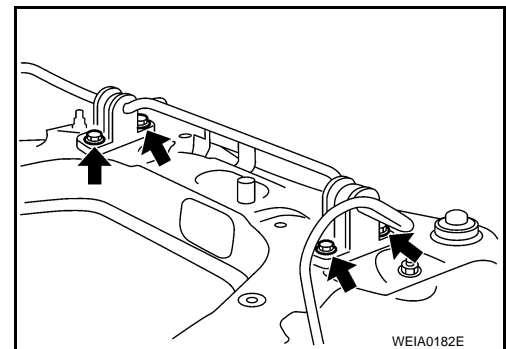

INSTALLATION

Note the following, and install in the reverse order of removal.

FRONT STABILIZER

< REMOVAL AND INSTALLATION >

- Install stabilizer clamp that notch (A) becomes vehicle front side (⇐).
- Install stabilizer bushing that slit (B) becomes vehicle front side (⇐).

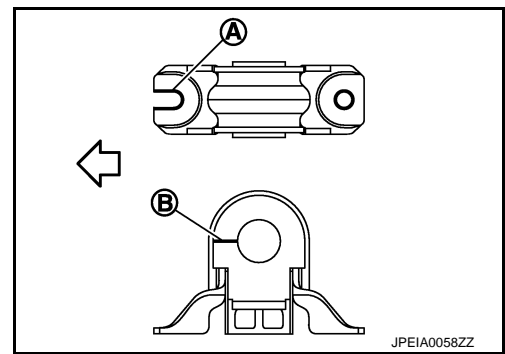

Inspection

INFOID:000000009721413

INSPECTION AFTER REMOVAL

Check stabilizer bar, stabilizer connecting rod, stabilizer bushing and stabilizer clamp for deformation, cracks or damage. Replace it if necessary.

FSU

F
G
H
I
J
K
L
M
N
O
P

FRONT SUSPENSION MEMBER

< UNIT REMOVAL AND INSTALLATION >

UNIT REMOVAL AND INSTALLATION

FRONT SUSPENSION MEMBER

Exploded View

INFOID:000000009721414

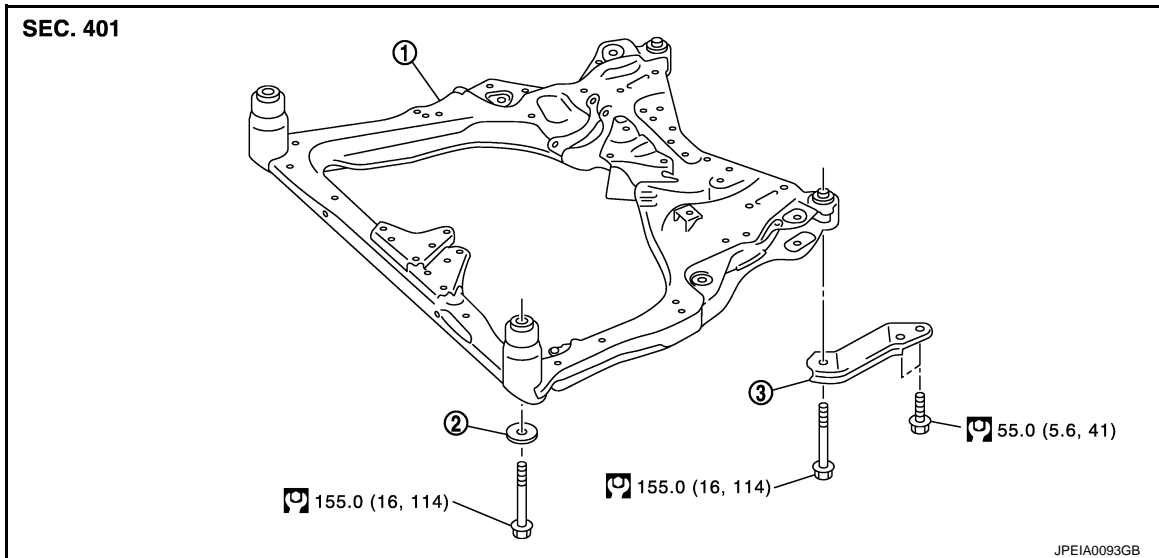

1. Front suspension member 2. Rebound stopper 3. Front suspension member stay

Refer to [GI-4. "Components"](#) for symbols in the figure.

Removal and Installation

INFOID:000000009721415

REMOVAL

1. Remove tires with power tool.
2. Remove air guide mounting nuts (←) and air guide (1).
3. At first, remove the engine and the transaxle assembly with front suspension member downward. Then separate the engine, transaxle and drive shaft. Refer to [EM-72. "2WD : Exploded View"](#) (2WD), [EM-81. "AWD : Exploded View"](#) (AWD).
4. Remove the following parts.
 - Steering knuckle and wheel hub and bearing assembly: Refer to [FAX-11. "Exploded View"](#) (2WD), [FAX-38. "Exploded View"](#) (AWD).
 - Steering gear assembly and hydraulic line: Refer to [ST-46. "Exploded View"](#) and [ST-64. "Exploded View"](#).
 - Stabilizer bar: Refer to [FSU-14. "Exploded View"](#).
 - Transverse link: Refer to [FSU-12. "Exploded View"](#).

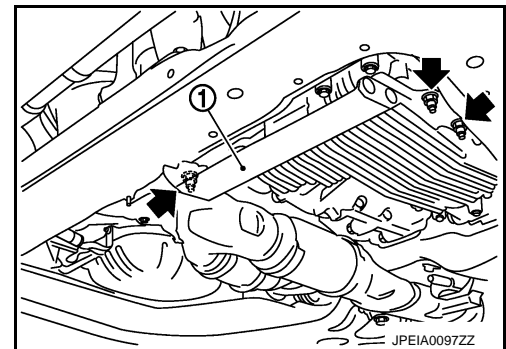

INSTALLATION

Note the following, and install in the reverse order of removal.

- Perform final tightening of installation position between front suspension member and transverse links (rubber bushing) under unladen condition with tires on level ground.

Inspection

INFOID:000000009721416

INSPECTION AFTER REMOVAL

Check the front suspension member for significant deformation, cracks, or damages. Replace it if necessary.

INSPECTION AFTER INSTALLATION

FRONT SUSPENSION MEMBER

< UNIT REMOVAL AND INSTALLATION >

1. Check wheel sensor harness for proper connection. Refer to [BRC-123. "FRONT WHEEL SENSOR : Exploded View"](#).
2. Check wheel alignment. Refer to [FSU-7. "Inspection"](#).
3. Adjust neutral position of steering angle sensor. Refer to [BRC-9. "ADJUSTMENT OF STEERING ANGLE SENSOR NEUTRAL POSITION : Special Repair Requirement"](#).

A

B

C

D

FSU

F

G

H

I

J

K

L

M

N

O

P

SERVICE DATA AND SPECIFICATIONS (SDS)

< SERVICE DATA AND SPECIFICATIONS (SDS)

SERVICE DATA AND SPECIFICATIONS (SDS)

SERVICE DATA AND SPECIFICATIONS (SDS)

Wheel Alignment

INFOID:000000009721417

FOR USA AND MEXICO MODELS

Item		Standard		
Measurement wheel		Left side	Right side	
Camber Degree minute (Decimal degree)	Minimum	-1° 00' (-1.00°)	-1° 15' (-1.25°)	
	Nominal	-0° 15' (-0.25°)	-0° 30' (-0.50°)	
	Maximum	0° 30' (0.50°)	0° 15' (0.25°)	
	Left and right difference* ¹	-0° 18' (-0.30°) - 0° 48' (0.80°)		
Caster Degree minute (Decimal degree)	Minimum	3° 55' (3.92°)	4° 15' (4.25°)	
	Nominal	4° 40' (4.67°)	5° 00' (5.00°)	
	Maximum	5° 25' (5.41°)	5° 45' (5.75°)	
	Left and right difference* ¹	-0° 18' (-0.30°) - 0° 48' (0.80°)		
Kingpin inclination Degree minute (Decimal degree)	Minimum	12° 00' (12.00°)		
	Nominal	12° 45' (12.75°)		
	Maximum	13° 30' (13.50°)		
Toe-in	Total toe-in Distance	Minimum	Out 0.5 mm (Out 0.019 in)	
		Nominal	In 1.5 mm (In 0.059 in)	
		Maximum	In 3.5 mm In (0.137 in)	
	Total toe-angle Degree minute (Decimal degree)	Minimum	Out 0° 02' (Out 0.03°)	
		Nominal	In 0° 06' (In 0.1°)	
		Maximum	In 0° 14' (In 0.23°)	

Measure value under unladen*² conditions.

*1: A difference when assuming the left side a standard.

*2: Fuel, engine coolant and lubricant are full. Spare tire, jack, hand tools and mats are in designated positions.

FOR CANADA MODELS

Item		Standard	
Measurement wheel		Left side	Right side
Camber Degree minute (Decimal degree)	Minimum	-1° 00' (-1.00°)	-1° 15' (-1.25°)
	Nominal	-0° 15' (-0.25°)	-0° 30' (-0.50°)
	Maximum	0° 30' (0.50°)	0° 15' (0.25°)
	Left and right difference* ¹	-0° 18' (-0.30°) - 0° 48' (0.80°)	
Caster Degree minute (Decimal degree)	Minimum	3° 55' (3.92°)	4° 10' (4.17°)
	Nominal	4° 40' (4.67°)	4° 55' (4.92°)
	Maximum	5° 25' (5.41°)	5° 40' (5.66°)
	Left and right difference* ¹	-0° 18' (-0.30°) - 0° 48' (0.80°)	
Kingpin inclination Degree minute (Decimal degree)	Minimum	11° 55' (11.92°)	
	Nominal	12° 40' (12.67°)	
	Maximum	13° 25' (13.41°)	

SERVICE DATA AND SPECIFICATIONS (SDS)

< SERVICE DATA AND SPECIFICATIONS (SDS)

Item		Standard	
Toe-in	Total toe-in Distance	Minimum	Out 0.5 mm (Out 0.019 in)
		Nominal	In 1.5 mm (In 0.059 in)
		Maximum	In 3.5 mm (In 0.137 in)
	Total toe-angle Degree minute (Decimal degree)	Minimum	Out 0° 02' (Out 0.03°)
		Nominal	In 0° 06' (In 0.1°)
		Maximum	In 0° 14' (In 0.23°)

Measure value under unladen*² conditions.

*1: A difference when assuming the left side a standard.

*2: Fuel, engine coolant and lubricant are full. Spare tire, jack, hand tools and mats are in designated positions.

Ball Joint

INFOID:000000009721418

FSU

Item		Standard	
Swing torque	Transverse link	0.5 – 4.9 N·m (0.06 – 0.49 kg·m, 5 – 43 in-lb)	
Measurement on spring balance	Transverse link	11.1 – 108.9 N (1.2 – 11.1 kg, 3 – 24 lb)	
Axial end play		0 mm (0 in)	

Wheelarch Height

INFOID:000000009721419

FOR USA MODELS

Item	Standard					
	2WD			AWD		
Axle type						
Wheel size	18 inch		20 inch	18 inch		20 inch
Grade	S	SL	LE	S	SL	LE
Front (Hr)	846 mm (33.31 in)		845 mm (33.27 in)	846 mm (33.31 in)		845 mm (33.27 in)
Rear (Hr)	859 mm (33.82 in)	858 mm (33.78 in)		858 mm (33.78 in)		857 mm (33.74 in)

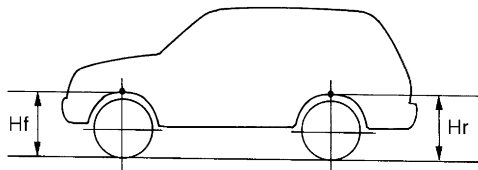

SFA746B

Measure value under unladen* conditions.

*: Fuel, engine coolant and lubricant are full. Spare tire, jack, hand tools and mats are in designated positions.

FOR CANADA MODELS

Item	Standard		
	Wheel size	18 inch	
Grade	S	SL	LE
Front (Hr)	845 mm (33.27 in)		846 mm (33.31 in)

SERVICE DATA AND SPECIFICATIONS (SDS)

< SERVICE DATA AND SPECIFICATIONS (SDS)

Item	Standard		
Wheel size	18 inch		20 inch
Grade	S	SL	LE
Rear (Hr)	858 mm (33.78 in)	857 mm (33.74 in)	

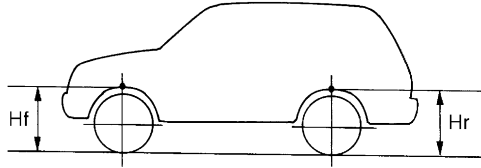

SFA746B

Measure value under unladen* conditions.

*: Fuel, engine coolant and lubricant are full. Spare tire, jack, hand tools and mats are in designated positions.

FOR MEXICO MODELS

Item	Standard		
Axle type	2WD		AWD
Grade	S	SL	LE
Front (Hr)	846 mm (33.31 in)		845 mm (33.27 in)
Rear (Hr)	859 mm (33.82 in)	858 mm (33.78 in)	857 mm (33.74 in)

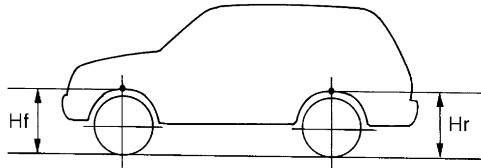

SFA746B

Measure value under unladen* conditions.

*: Fuel, engine coolant and lubricant are full. Spare tire, jack, hand tools and mats are in designated positions.