

A

# SECTION LU

LU

## ENGINE LUBRICATION SYSTEM

C

### CONTENTS

D

E

<b>PRECAUTION</b> .....	2	Changing Engine Oil .....	9	F
<b>PRECAUTIONS</b> .....	2	<b>OIL FILTER</b> .....	10	
Precaution for Supplemental Restraint System (SRS) "AIR BAG" and "SEAT BELT PRE-TENSIONER" .....	2	Removal and Installation .....	10	G
Precaution for Liquid Gasket .....	2	<b>REMOVAL AND INSTALLATION</b> .....	12	
<b>PREPARATION</b> .....	4	<b>OIL PUMP</b> .....	12	H
<b>PREPARATION</b> .....	4	Removal and Installation .....	12	
Special Service Tools .....	4	Disassembly and Assembly .....	12	
Commercial Service Tools .....	4	<b>OIL COOLER</b> .....	15	I
<b>SYSTEM DESCRIPTION</b> .....	6	Removal and Installation .....	15	
<b>LUBRICATION SYSTEM</b> .....	6	<b>SERVICE DATA AND SPECIFICATIONS (SDS)</b> .....	17	J
Engine Lubrication System .....	6	<b>SERVICE DATA AND SPECIFICATIONS (SDS)</b> .....	17	
Engine Lubrication System Schematic .....	7	Oil Pressure .....	17	K
<b>PERIODIC MAINTENANCE</b> .....	8	Regulator Valve .....	17	
<b>ENGINE OIL</b> .....	8	Oil Pump .....	17	L
Inspection .....	8	Oil Capacity .....	17	

M

N

O

P

# PRECAUTIONS

< PRECAUTION >

## PRECAUTION

### PRECAUTIONS

#### Precaution for Supplemental Restraint System (SRS) "AIR BAG" and "SEAT BELT PRE-TENSIONER"

INFOID:000000011583497

The Supplemental Restraint System such as "AIR BAG" and "SEAT BELT PRE-TENSIONER", used along with a front seat belt, helps to reduce the risk or severity of injury to the driver and front passenger for certain types of collision. Information necessary to service the system safely is included in the SR and SB section of this Service Manual.

#### **WARNING:**

- To avoid rendering the SRS inoperative, which could increase the risk of personal injury or death in the event of a collision which would result in air bag inflation, all maintenance must be performed by an authorized NISSAN/INFINITI dealer.
- Improper maintenance, including incorrect removal and installation of the SRS, can lead to personal injury caused by unintentional activation of the system. For removal of Spiral Cable and Air Bag Module, see the SR section.
- Do not use electrical test equipment on any circuit related to the SRS unless instructed to in this Service Manual. SRS wiring harnesses can be identified by yellow and/or orange harnesses or harness connectors.

#### PRECAUTIONS WHEN USING POWER TOOLS (AIR OR ELECTRIC) AND HAMMERS

#### **WARNING:**

- When working near the Airbag Diagnosis Sensor Unit or other Airbag System sensors with the Ignition ON or engine running, DO NOT use air or electric power tools or strike near the sensor(s) with a hammer. Heavy vibration could activate the sensor(s) and deploy the air bag(s), possibly causing serious injury.
- When using air or electric power tools or hammers, always switch the Ignition OFF, disconnect the battery and wait at least three minutes before performing any service.

#### Precaution for Liquid Gasket

INFOID:000000011583498

#### REMOVAL OF LIQUID GASKET SEALING

- After removing the bolts and nuts, separate the mating surface and remove the liquid gasket using Tool (A).

**Tool Number** : KV10111100 (J-37228)

#### **CAUTION:**

**Be careful not to damage the mating surfaces.**

- In areas where the cutter is difficult to use, use a plastic hammer to lightly tap (1) the cutter where the liquid gasket is applied. Use a plastic hammer to slide (2) the cutter by tapping on the side.

#### **CAUTION:**

**Do not damage the mating surfaces.**

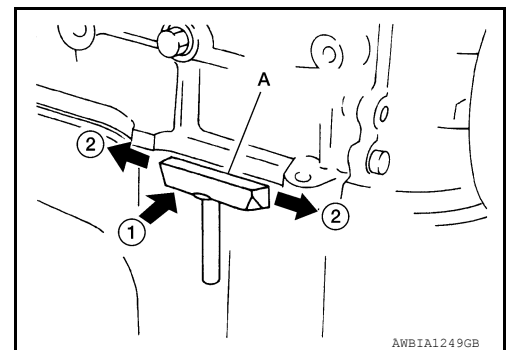

#### LIQUID GASKET APPLICATION PROCEDURE

1. Using suitable tool (A), remove old liquid gasket adhering to the liquid gasket application surface and the mating surface.
  - Remove liquid gasket completely from the groove of the liquid gasket application surface, mounting bolts, and bolt holes.
2. Thoroughly clean the mating surfaces and remove adhering moisture, grease and foreign materials.

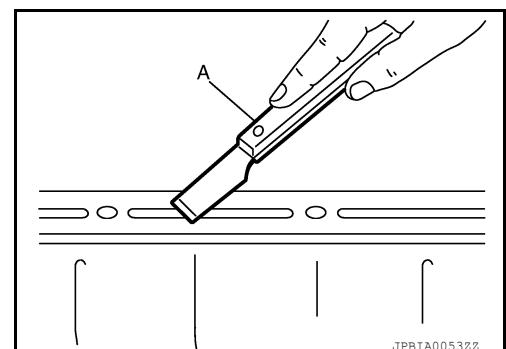

# PRECAUTIONS

## < PRECAUTION >

3. Attach liquid gasket tube to the suitable tool.  
**Use Genuine Silicone RTV Sealant, or equivalent. Refer to [GI-22, "Recommended Chemical Products and Sealants"](#).**
4. Apply liquid gasket without gaps to the specified location according to the specified dimensions.
  - If there is a groove for liquid gasket application, apply liquid gasket to the groove.

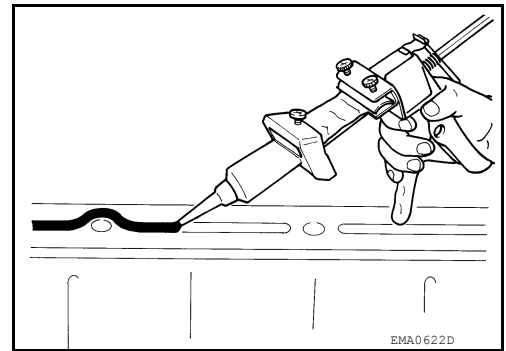

- As for bolt holes (B), normally apply liquid gasket inside the holes. Occasionally, it should be applied outside the holes. Check to read the text of this manual.

(A) : Groove

⇐ : Inside

- Within five minutes of liquid gasket application, install the mating component.
- If liquid gasket protrudes, wipe it off immediately.
- Do not retighten mounting bolts or nuts after the installation.
- After 30 minutes or more have passed from the installation, fill engine oil and engine coolant. Refer to [LU-9, "Changing Engine Oil"](#) and [CO-9, "Changing Engine Coolant"](#).

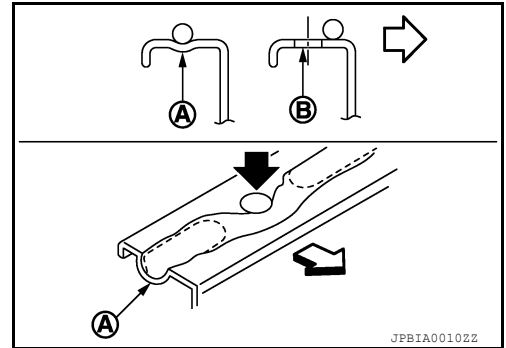

### **CAUTION:**

**If there are more specific instructions in the procedures contained in this manual concerning liquid gasket application, observe them.**

# PREPARATION

< PREPARATION >

## PREPARATION

### PREPARATION

#### Special Service Tools

INFOID:000000011583499

The actual shape of the tools may differ from those illustrated here.

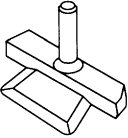
Tool number (TechMate No.) Tool name	Description
KV10111100 (J-37228) Seal cutter   NT046	Removing oil pan (lower) etc.

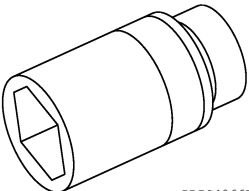
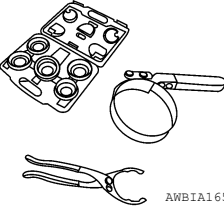
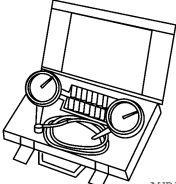

#### Commercial Service Tools

INFOID:000000011583500

Tool number (TechMate No.) Tool name	Description
Deep socket   PBIC4066E	Removing and installing oil pressure sensor <b>27 mm (1.06 in)</b>
— (223-50000) Oil filter wrench assortment   AWBIA1656ZZ	Removing oil filter
— (16-5610) Oil pressure kit   AWBIA1657ZZ	Measuring oil pressure. Comes with adapter and hose. Designed to be used for both static and on-road testing.

# PREPARATION

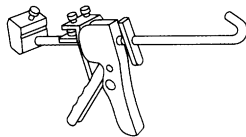
## < PREPARATION >

Tool number (TechMate No.) Tool name	Description
Tube presser   NT052	Pressing the tube of liquid gasket  LU
Power tool   PIIB1407E	Loosening nuts, screws and bolts  D E F

A

LU

C

D

E

F

G

H

I

J

K

L

M

N

O

P

# LUBRICATION SYSTEM

< SYSTEM DESCRIPTION >

## SYSTEM DESCRIPTION

### LUBRICATION SYSTEM

#### Engine Lubrication System

INFOID:000000011596655

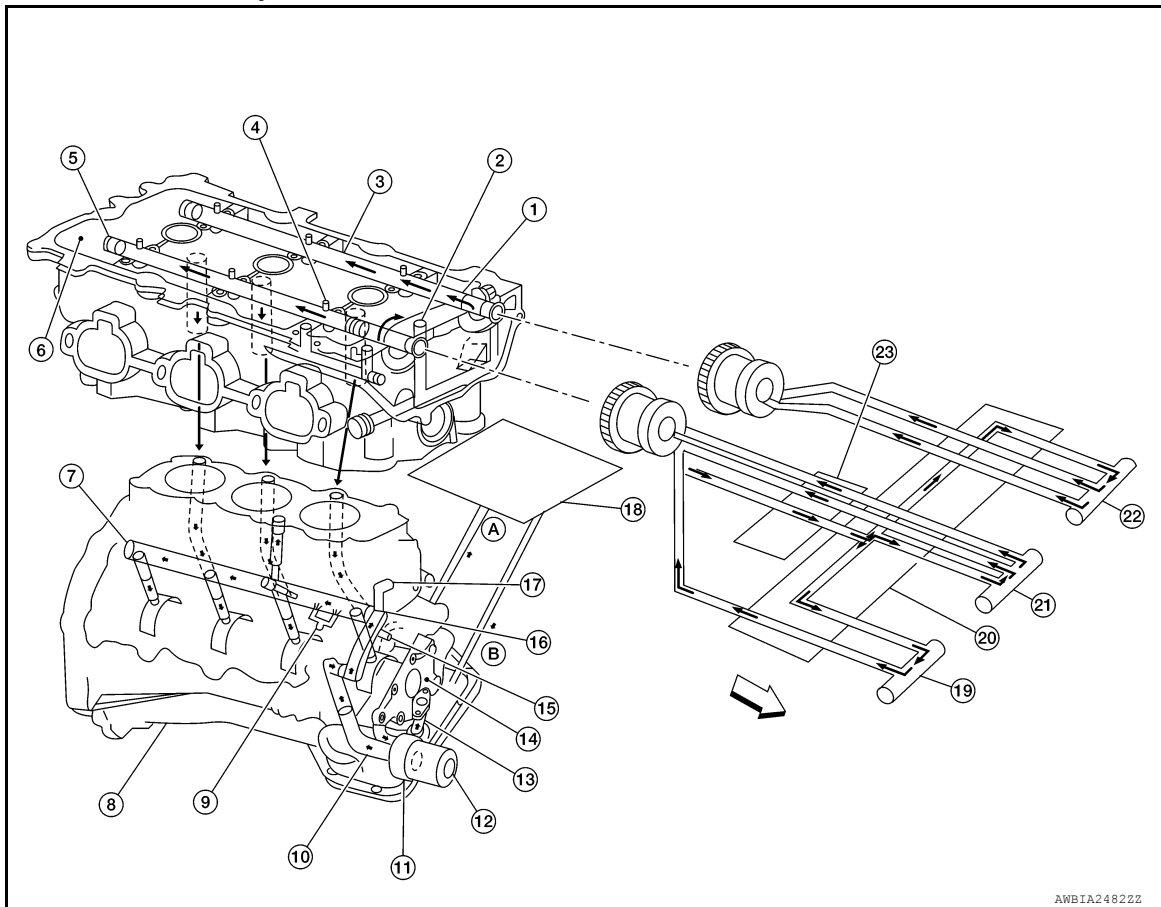

AWBIA2482ZZ

- |                                                                           |                                         |                                                          |
|---------------------------------------------------------------------------|-----------------------------------------|----------------------------------------------------------|
| 1. Camshaft (EXH) journal (No. 1)                                         | 2. Timing chain tensioner (secondary)   | 3. Camshaft (EXH)                                        |
| 4. Camshaft (INT) journal (No. 2)                                         | 5. Camshaft (INT)                       | 6. Cylinder head (bank 2)                                |
| 7. Main oil gallery                                                       | 8. Upper oil pan                        | 9. Piston oil jet                                        |
| 10. Oil pan oil gallery                                                   | 11. Oil cooler                          | 12. Oil filter                                           |
| 13. Oil strainer                                                          | 14. Oil pump                            | 15. Timing chain oil jet                                 |
| 16. Timing chain case oil gallery                                         | 17. Timing chain tensioner (primary)    | 18. Timing chain case                                    |
| 19. Intake valve timing control solenoid valve (bank 2)                   | 20. Valve timing control cover (bank 2) | 21. Exhaust valve timing control solenoid valve (bank 2) |
| 22. Intake valve timing intermediate lock control solenoid valve (bank 2) | 23. Front cover                         | A. To timing chain case                                  |
| B. From timing chain case                                                 | ⇐ Engine front                          |                                                          |

# LUBRICATION SYSTEM

< SYSTEM DESCRIPTION >

## Engine Lubrication System Schematic

INFOID:000000011596656

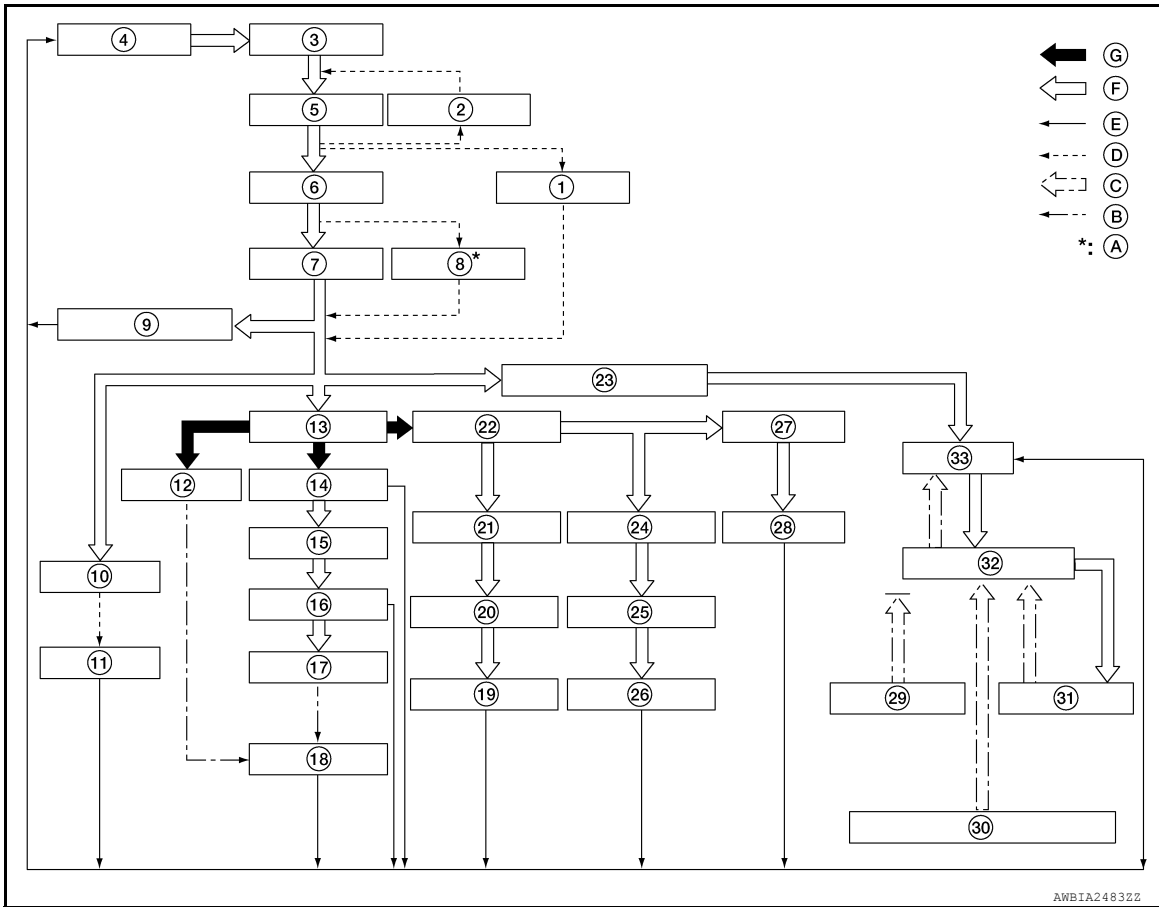

- |                                                                           |                                                         |                                                          |
|---------------------------------------------------------------------------|---------------------------------------------------------|----------------------------------------------------------|
| 1. Relief valve                                                           | 2. Regulator valve                                      | 3. Oil strainer                                          |
| 4. Oil pan                                                                | 5. Oil pump                                             | 6. Oil cooler                                            |
| 7. Oil filter                                                             | 8. Relief valve                                         | 9. Timing chain tensioner (primary)                      |
| 10. Timing chain oil jet                                                  | 11. Timing chain                                        | 12. Piston oil jet                                       |
| 13. Main oil gallery                                                      | 14. Main bearing                                        | 15. Crankshaft                                           |
| 16. Connecting rod bearing                                                | 17. Connecting rod                                      | 18. Piston                                               |
| 19. Intake camshaft journal (No. 3, 4)                                    | 20. Camshaft oil passage                                | 21. Intake camshaft journal (No. 1)                      |
| 22. Cylinder head oil gallery                                             | 23. Rear timing chain case                              | 24. Exhaust camshaft journal (No. 1)                     |
| 25. Camshaft oil passage                                                  | 26. Exhaust camshaft journal (No. 2, 3, 4)              | 27. Timing chain tensioner (secondary oil gallery)       |
| 28. Timing chain tensioner (secondary)                                    | 29. Intake valve timing control solenoid valve (bank 2) | 30. Exhaust valve timing control solenoid valve (bank 2) |
| 31. Intake valve timing intermediate lock control solenoid valve (bank 2) | A. Built into oil filter                                | B. Oil injection                                         |
| C. Return oil passage                                                     | D. Bypass                                               | E. To oil pan                                            |
| F. Oil passage                                                            | G. Main oil gallery                                     |                                                          |

# ENGINE OIL

< PERIODIC MAINTENANCE >

## PERIODIC MAINTENANCE

### ENGINE OIL

#### Inspection

INFOID:000000011583503

#### ENGINE OIL LEVEL

##### NOTE:

- Before starting the engine, check the engine oil level. If the engine is already started, stop it and allow 10 minutes before checking.
- Check that the engine oil level is within the range as indicated on the dipstick.
- If it is out of range (A), add engine oil as necessary until the dipstick indicates the correct level.

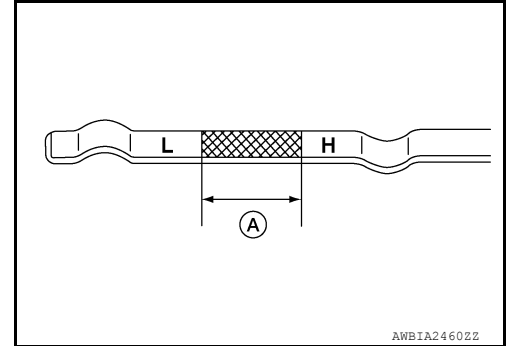

#### ENGINE OIL APPEARANCE

- Check engine oil for white milky appearance or excessive contamination.
- If engine oil becomes milky, it is highly probable that it is contaminated with engine coolant. Repair or replace damaged parts.

#### ENGINE OIL LEAKS

Check for engine oil leaks around the following areas:

- Oil pan
- Oil pan drain plug
- Oil pressure switch
- Oil filter
- Oil cooler
- Intake valve timing control cover
- Front timing chain cover
- Mating surface between cylinder block and cylinder head
- Mating surface between cylinder head and rocker cover
- Front oil seal
- Rear oil seal

#### ENGINE OIL PRESSURE CHECK

##### WARNING:

- **Be careful not to burn yourself, as engine oil may be hot.**
- **When checking engine oil pressure, shift selector position should be "P", and apply parking brake securely.**

1. Check the engine oil level. Refer to ENGINE OIL LEVEL.
2. Remove fender protector side cover. Refer to [EXT-36. "FENDER PROTECTOR : Exploded View"](#).
3. Disconnect oil pressure switch harness connector at the oil pressure switch. Remove oil pressure switch using suitable tool and install suitable tools (A/B).

##### CAUTION:

**Do not drop or shock oil pressure switch.**

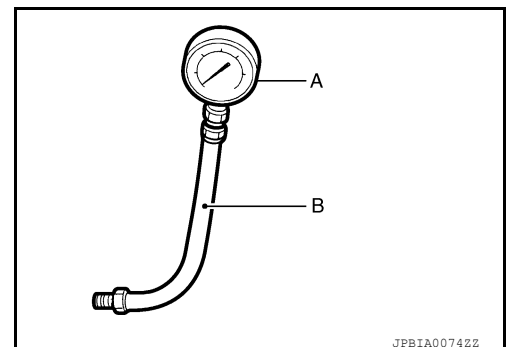

4. Start the engine and warm it up to normal operating temperature.



# ENGINE OIL

## < PERIODIC MAINTENANCE >

5. Check oil pressure with engine running under no-load, using suitable tool.

**NOTE:**

- When engine oil temperature is low, engine oil pressure becomes high.
- If difference is extreme, check oil passage and oil pump for oil leaks.

**Engine oil pressure** : [LU-17, "Oil Pressure"](#)

6. After the inspections, install the oil pressure switch using suitable tool as follows:

- a. Remove the old sealant adhering to oil pressure switch and engine.

- b. Apply thread sealant and tighten the oil pressure switch to specification.

**Use Genuine High Performance Thread Sealant, or equivalent. Refer to [GI-22, "Recommended Chemical Products and Sealants"](#).**

**Oil pressure switch** : [EM-113, "Exploded View"](#)

- c. After warming up engine, make sure there are no engine oil leaks.

7. Install fender protector side cover. Refer to [EXT-36, "FENDER PROTECTOR : Exploded View"](#).

## Changing Engine Oil

INFOID:000000011583504

**WARNING:**

- **Be careful not to burn yourself, as the engine oil may be hot.**
- **Prolonged and repeated contact with used engine oil may cause skin cancer; try to avoid direct skin contact with used engine oil. If skin contact is made, wash thoroughly with soap or hand cleaner as soon as possible.**

1. Position the vehicle so it is level on the hoist.
2. Warm up the engine and check for engine oil leaks from the engine.
3. Stop engine and wait for 10 minutes.
4. Remove the oil pan drain plug (1) and oil filler cap.

↔ : Front

5. Drain the engine oil.
6. Install the oil pan drain plug (1) with a new washer and refill the engine with new engine oil.

**Lower oil pan drain plug torque** : Refer to [EM-38, "Exploded View"](#).

**Oil specification and viscosity** : Refer to [MA-12, "Engine Oil Recommendation"](#).

**CAUTION:**

- **Be sure to clean the oil pan drain plug and install with a new washer.**
- **The refill capacity depends on the oil temperature and drain time. Use these specifications for reference only. Always use the dipstick to determine when the proper amount of oil is in the engine.**

7. Warm up the engine and check around the oil pan drain plug and oil filter for oil leaks.
8. Stop engine and wait for 10 minutes.
9. Check the engine oil level using the oil level gauge.

**CAUTION:**

**Do not overfill the engine with engine oil.**

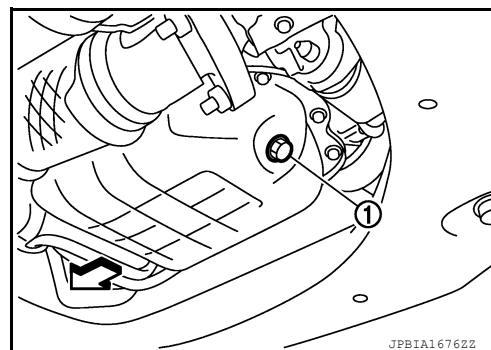

JPBIA16762Z

# OIL FILTER

< PERIODIC MAINTENANCE >

## OIL FILTER

### Removal and Installation

INFOID:000000011578423

#### REMOVAL

1. Drain engine oil. Refer to [LU-9, "Changing Engine Oil"](#).
2. Remove front fender protector side cover RH. Refer to [EXT-36, "FENDER PROTECTOR : Exploded View"](#).
3. Remove the oil filter using suitable tool (A) as shown.

**Tool number (A) : KV10115801 (J-38956)**

#### **WARNING:**

Be careful not to burn yourself, as the engine oil may be hot.

#### **CAUTION:**

- When removing, prepare a shop cloth to absorb any engine oil leaks or spills.
  - Do not allow engine oil to adhere to the drive belts.
  - Completely wipe off any engine oil that adheres to the engine and the vehicle.
- 
- The oil filter is provided with a relief valve. Use a Genuine NISSAN oil filter or equivalent.

- (A.) : Oil filter body  
(B.) : Relief valve  
(C.) : Filtering paper  
(D.) : Screw  
(E.) : Packing

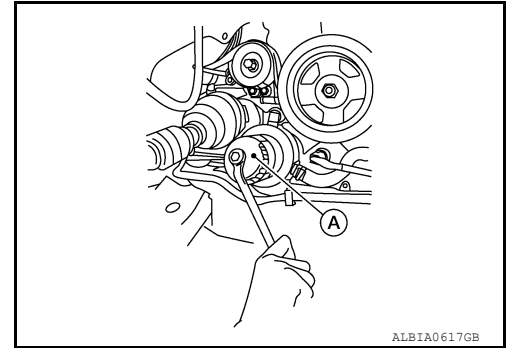

ALBIA0617GB

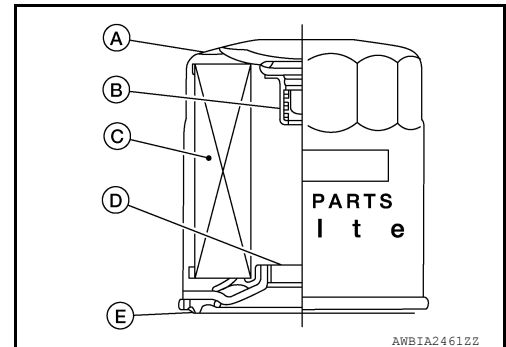

AWBIA24612Z

#### INSTALLATION

1. Remove foreign materials adhering to the oil filter installation surface.
2. Apply clean engine oil to the oil seal contact surface of the new oil filter.

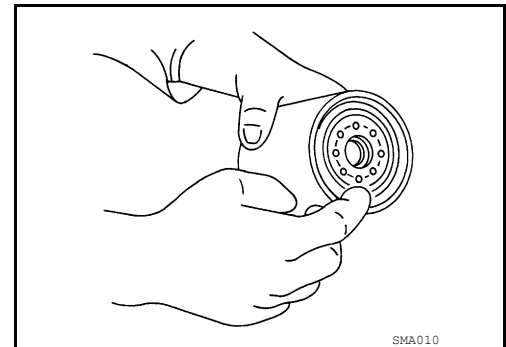

SMA010

## OIL FILTER

### < PERIODIC MAINTENANCE >

3. Screw the oil filter manually until it touches the installation surface, then tighten it by turning another 2/3 turn or tighten to specification using a suitable tool.

**Oil filter : 18.0 N·m (1.8 kg·m, 13 ft·lb)**

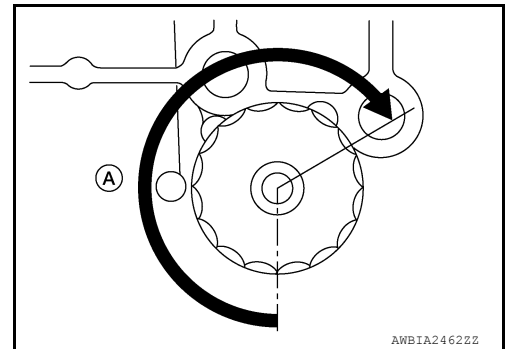

4. Refill the engine with new engine oil. Refer to [LU-9, "Changing Engine Oil"](#).
5. Check the engine oil level and add engine oil as necessary. Refer to [LU-8, "Inspection"](#).
6. After warming up the engine, check for engine oil leaks.
7. Install front fender protector side cover RH. Refer to [EXT-36, "FENDER PROTECTOR : Exploded View"](#).

A

LU

C

D

E

F

G

H

I

J

K

L

M

N

O

P

# OIL PUMP

< REMOVAL AND INSTALLATION >

## REMOVAL AND INSTALLATION

### OIL PUMP

#### Removal and Installation

INFOID:000000011578424

#### REMOVAL

1. Remove the engine from the vehicle. Refer to [EM-104. "FWD : Removal and Installation"](#) (FWD) or [EM-109. "AWD : Removal and Installation"](#) (AWD).
2. Remove the upper oil pan. Refer to [EM-39. "Removal and Installation \(Upper Oil Pan\)"](#).
3. Remove the timing chain. Refer to [EM-65. "Removal and Installation"](#).
4. Remove oil pump assembly.

#### INSTALLATION

Installation is in the reverse order of removal.

#### Disassembly and Assembly

INFOID:000000011578425

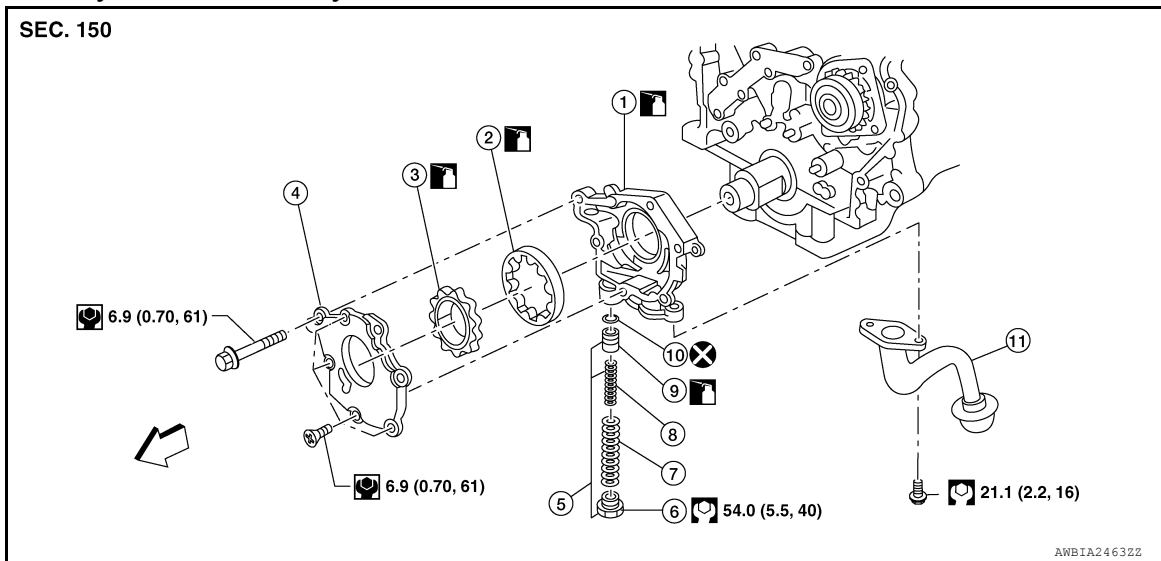

- |                            |                                 |                         |
|----------------------------|---------------------------------|-------------------------|
| 1. Oil pump housing        | 2. Outer pump outer rotor       | 3. Oil pump inner rotor |
| 4. Oil pump cover          | 5. Regulator valve set assembly | 6. Regulator valve plug |
| 7. Regulator valve spring  | 8. Regulator valve spring       | 9. Regulator valve      |
| 10. Regulator valve O-ring | 11. Oil strainer                | ⇐ Front                 |

#### CAUTION:

Before assembly, apply new engine oil to the parts as shown.

#### DISASSEMBLY

1. Remove the oil pump cover.
2. Remove inner rotor and outer rotor from oil pump housing.

#### CAUTION:

The outer rotor has directional vanes in relation to the rotation of the oil pump shaft. Note the outer rotor vane direction for assembly.

3. Remove oil strainer from oil pump housing.
4. After removing regulator plug, remove spring and regulator valve.

#### INSPECTION AFTER DISASSEMBLY

Clearance of Oil Pump Parts

# OIL PUMP

## < REMOVAL AND INSTALLATION >

- Measure clearance using suitable tool (A).
- Clearance between outer rotor and oil pump body (position 1).

**Standard** : [LU-17, "Oil Pump"](#)

- Tip clearance between inner rotor and outer rotor (position 2).

**Standard** : [LU-17, "Oil Pump"](#)

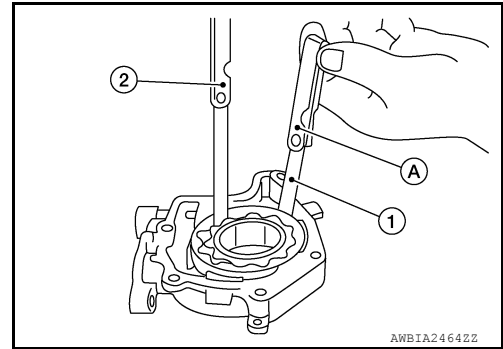

- Measure clearance using suitable tools (A/B).
- Side clearance between inner rotor and oil pump body (position 3).

**Standard** : [LU-17, "Oil Pump"](#)

- Side clearance between outer rotor and oil pump body (position 4).

**Standard** : [LU-17, "Oil Pump"](#)

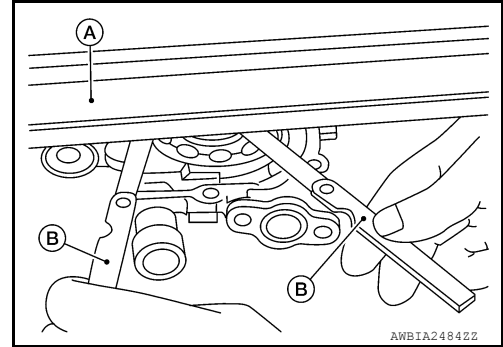

- Calculate the clearance between inner rotor (1) and oil pump body as follows:

1. Measure the outer diameter of protruded portion of inner rotor (position A).
2. Measure the inner diameter of oil pump body with inside micrometer (position B).  
(clearance 5) = (inner diameter of oil pump body B) – (outer diameter of inner rotor A)

**Standard** : [LU-17, "Oil Pump"](#)

3. If out of specifications, replace oil pump assembly.

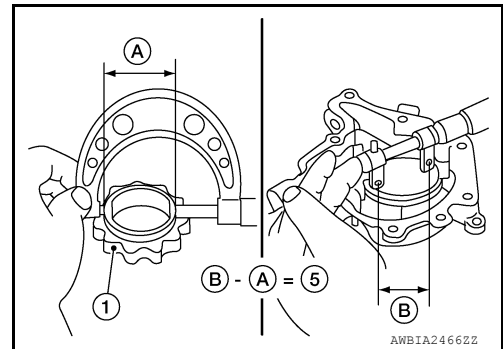

## Regulator Valve

1. Visually inspect components for wear and damage, including regulator plug (C).
2. Check oil pressure regulator valve (A) sliding surface and valve spring (B).
3. Coat regulator valve with engine oil. Check that it falls smoothly into the valve hole by its own weight.  
**If damaged, replace oil pump assembly.**

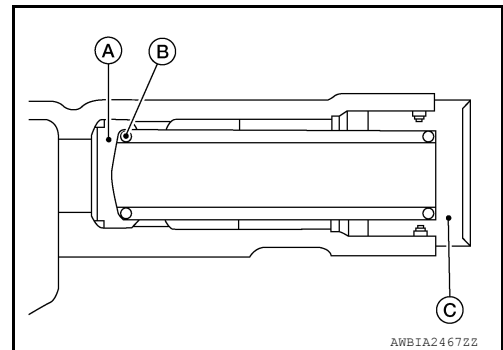

## Regulator Valve Clearance

# OIL PUMP

## < REMOVAL AND INSTALLATION >

(Clearance 6) = D (Valve hole diameter) – E (Outer diameter of valve)

**Standard** : [LU-17, "Regulator Valve"](#)

- 1. : Regulator valve
- 2. : Oil pump body

If it exceeds the standard, replace the oil pump assembly.

### CAUTION:

- Coat regulator valve with engine oil.
- Check that it falls smoothly into the valve hole by its own weight.

### Assembly

Assembly is in the reverse order of disassembly.

- Assemble the outer rotor in the correct vane orientation to rotation as noted during disassembly and the inner rotor with the groove on the oil pump cover side.

### CAUTION:

- Do not reuse O-ring.
- Before assembly apply new engine oil to the parts as specified.

- A. : Housing side
- B. : Cover side
- C. : Groove

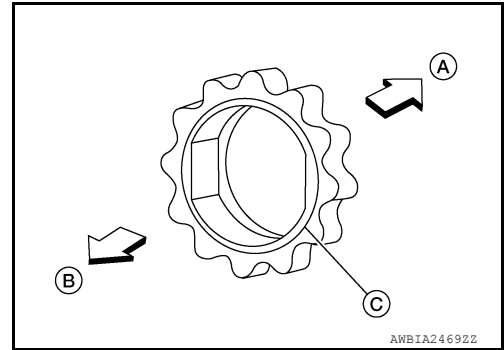
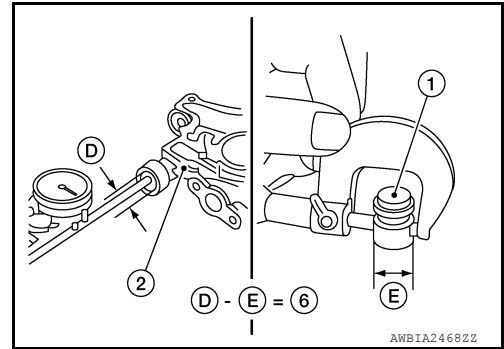

# OIL COOLER

< REMOVAL AND INSTALLATION >

## OIL COOLER

### Removal and Installation

INFOID:000000011578426

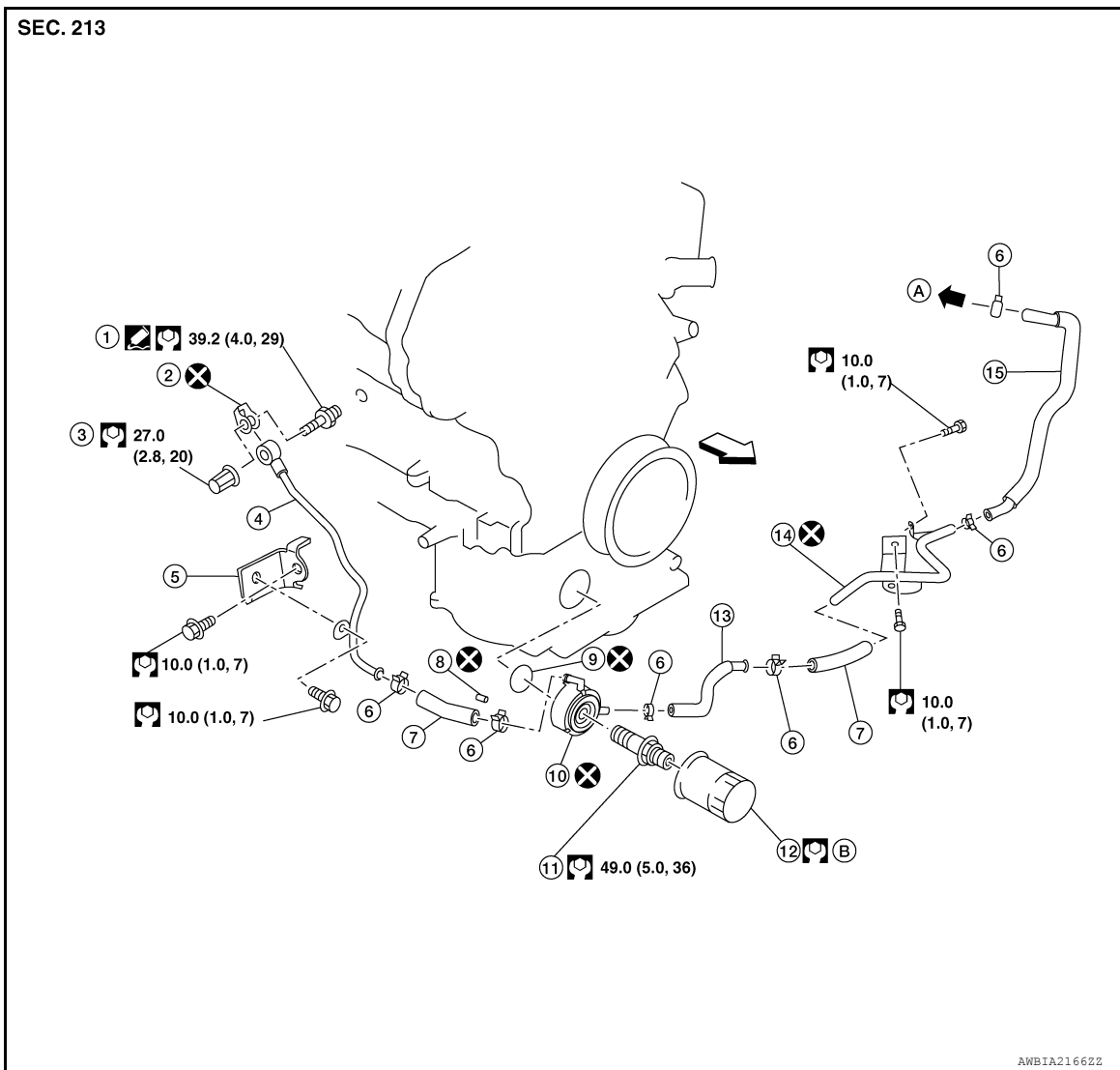

- |                       |                          |                      |
|-----------------------|--------------------------|----------------------|
| 1. Connector bolt     | 2. Copper gasket         | 3. Water drain plug  |
| 4. Water pipe         | 5. Bracket               | 6. Clamp             |
| 7. Water hose         | 8. Relief valve          | 9. Oil cooler O-Ring |
| 10. Oil cooler        | 11. Connector bolt       | 12. Oil filter       |
| 13. Water hose        | 14. Water pipe           | 15. Water hose       |
| A. To water connector | B. Refer to INSTALLATION | ⇐ Engine front       |

#### **WARNING:**

Be careful not to burn yourself, as the engine oil may be hot.

#### **CAUTION:**

- When removing oil cooler, prepare a shop cloth to absorb any engine oil leaks or spillage.
- Completely wipe off any engine oil that adheres to the engine and the vehicle.

#### **NOTE:**

When removing components such as hoses, tubes/lines, etc., cap or plug openings to prevent fluid from spilling.

#### REMOVAL

1. Remove the engine under cover. Refer to [EXT-40, "FRONT UNDER COVER : Removal and Installation"](#).

## OIL COOLER

### < REMOVAL AND INSTALLATION >

---

2. Remove wheel and tire (RH) using a power tool. Refer to [WT-68, "Removal and Installation"](#).
3. Remove the front fender protector side cover RH. Refer to [EXT-36, "FENDER PROTECTOR : Exploded View"](#).
4. Drain engine coolant. Refer to [CO-9, "Changing Engine Coolant"](#).  
**CAUTION:**  
**Do not spill engine coolant on the drive belt.**
5. Disconnect water hoses from oil cooler.
6. Remove the oil filter. Refer to [LU-10, "Removal and Installation"](#).
7. Remove oil cooler.

### INSPECTION AFTER REMOVAL

1. Check oil cooler for cracks.
2. Check oil cooler for clogging by blowing through coolant inlet. If necessary, replace oil cooler.

#### Oil Pressure Relief Valve

Inspect oil pressure relief valve for movement, cracks and breaks by pushing the ball. If replacement is necessary, remove valve by prying it out with a suitable tool. Install a new valve in place by tapping it.

### INSTALLATION

Installation is in the reverse order of removal.

#### **CAUTION:**

- **Do not reuse O-ring.**
- **Do not reuse copper gasket.**
- **When installing the oil cooler, align the oil cooler slot with the stopper of the oil pan.**

### INSPECTION AFTER INSTALLATION

1. Check the engine oil level and the engine coolant level and add engine oil and engine coolant. Refer to [LU-8, "Inspection"](#) (Engine oil) and [CO-8, "System Inspection"](#) (Engine Coolant).
2. Start the engine, and check that there are no leaks of engine oil or engine coolant.
3. Stop the engine and wait for 10 minutes.
4. Check the engine oil level and the engine coolant level again. Refer to [LU-8, "Inspection"](#) and [CO-9, "Changing Engine Coolant"](#).



# SERVICE DATA AND SPECIFICATIONS (SDS)

< SERVICE DATA AND SPECIFICATIONS (SDS)

## SERVICE DATA AND SPECIFICATIONS (SDS)

### SERVICE DATA AND SPECIFICATIONS (SDS)

#### Oil Pressure

INFOID:0000000011578427

Unit: kPa (kg/cm<sup>2</sup>, psi)

Engine speed	Approximate discharge engine oil pressure
600 rpm	98 or higher (1.0, 14)
2,000 rpm	294 (3.0, 42.6)
6,000 rpm	392 (4.0, 56.8)

#### Regulator Valve

INFOID:0000000011578428

Unit: mm (in)

Regulator valve to oil pump body clearance	0.040 - 0.097 (0.0016 - 0.0038)
--------------------------------------------	---------------------------------

#### Oil Pump

INFOID:0000000011578429

Unit: mm (in)

Oil pump body to outer rotor radial clearance	0.114 - 0.260 (0.0045 - 0.0102)
Inner rotor to outer rotor tip clearance	0.180 or below (0.0071)
Oil pump body to inner rotor side clearance	0.030 - 0.070 (0.0012 - 0.0028)
Oil pump body to outer rotor side clearance	0.030 - 0.090 (0.0012 - 0.0035)
Socket to spigot joint of oil pump body clearance	0.045 - 0.091 (0.0018 - 0.0036)

#### Oil Capacity

INFOID:0000000011578430

Unit: ℓ (US qt, Imp qt)

Drain and refill	With engine oil filter change	Approximately 4.8 (5-1/8, 4-1/4)
	Without engine oil filter change	Approximately 4.5 (4-3/4, 4)
Dry engine (engine overhaul)		Approximately 5.2 (5-1/2, 4-5/8)